

Yury G. Aliakseyeu<sup>1</sup>, Aleksandr Yu. Korolyov<sup>1</sup>, Vladimir S. Niss<sup>2</sup>, Alexey S. Budnitsky<sup>1</sup>

<sup>1</sup>Scientific and Technological Park BNTU “Polytechnic”, Minsk, Republic of Belarus

<sup>2</sup>Belarusian National Technical University, Minsk, Republic of Belarus

## ELECTROCHEMICAL POLISHING OF MATRIX STENTS OF THE 316LVM STEEL USING MICROSECOND PULSES

**Abstract.** With the development of minimally invasive treatment technology, coronary stents made of corrosion-resistant steel are in demand for restoring the patency of blood vessels. The effectiveness of coronary stenting depends on various factors, but the quality of the surface of the stents is a major factor. The higher the quality of the surface of the stent is, the less negative the effect on the circulatory system, arterial walls, and the higher the biocompatibility of the stent is. The complex shape, small cross-section, size, and low rigidity of coronary stents are the main reasons for the inability to ensure high surface quality using mechanical finishing methods. Therefore, electrochemical methods are used to polish stents. For electrochemical polishing (ECP) of stents, an electric mode based on direct current is traditionally used. The disadvantages of direct current ECP are excessive metal removal and the need to use electrolytes of complex compositions, often containing toxic components. As an alternative to the traditional ECP with the use of direct current, we have proposed a method of pulsed ECP using pulses of microsecond duration for polishing stents. The use of pulsed current allows one to achieve a significant increase in the efficiency of the SEC process, when, due to the localization of the anodic dissolution, the smoothing speed of the microroughness of the treated surface, referred to the total metal removal, increases significantly. The paper presents a comparative analysis of ECP modes using direct and pulse current to change the surface roughness, removal, radius of curvature of the edges, and corrosion resistance on the example of stents made of the 316LVM stainless steel. Based on the results of the studies, technological regimes of pulsed ECP were established that provide the highest quality polishing of the stent surface with a small metal removal with a slight rounding of the edges.

**Keywords:** current pulse, electrochemical polishing, coronary stent, electrolyte, efficiency of smoothing microroughness, microroughness

**For citation:** Aliakseyeu Y. G., Korolyov A. Yu., Niss V. S., Budnitsky A. S. Electrochemical polishing of matrix stents of the 316LVM steel using microsecond pulses. *Vesti Natsyyanal'nai akademii navuk Belarusi. Seryya fizika-tekhnichnykh navuk = Proceedings of the National Academy of Sciences of Belarus. Physical-technical series*, 2021, vol. 66, no. 2, pp. 161–168. <https://doi.org/10.29235/1561-8358-2021-66-2-161-168>

Ю.Г. Алексеев<sup>1</sup>, А.Ю. Королев<sup>1</sup>, В.С. Нисс<sup>2</sup>, А.С. Будницкий<sup>1</sup>

<sup>1</sup>Научно-технологический парк БНТУ «Политехник», Минск, Республика Беларусь

<sup>2</sup>Белорусский национальный технический университет, Минск, Республика Беларусь

## ЭЛЕКТРОХИМИЧЕСКОЕ ПОЛИРОВАНИЕ МАТРИЧНЫХ СТЕНТОВ ИЗ СТАЛИ 316LVM С ИСПОЛЬЗОВАНИЕМ МИКРОСЕКУНДНЫХ ИМПУЛЬСОВ

**Аннотация.** С развитием технологии малоинвазивного лечения коронарные стенты из коррозионностойких сталей получили широкое распространение при восстановлении проходимости кровеносных сосудов. Эффективность стентирования коронарных сосудов зависит от различных факторов, однако основным фактором является качество поверхности стентов. Чем выше качество поверхности стента, тем меньше негативное влияние оказывается на кровеносную систему, стенки артерий и тем выше биологическая совместимость стента. Сложная форма, малое сечение, размеры и низкая жесткость коронарных стентов являются основными причинами невозможности обеспечения высокого качества поверхности с использованием механических способов финишной обработки. Поэтому для полирования стентов применяются электрохимические методы. Для электрохимического полирования (ЭХП) стентов традиционно используется электрический режим, основанный на постоянном токе. Недостатками ЭХП на постоянном токе являются чрезмерный съем металла и необходимость использования электролитов сложных составов, часто содержащих токсичные компоненты. В качестве альтернативы традиционному ЭХП с применением постоянного тока нами для полирования стентов предложен метод импульсного ЭХП с использованием импульсов микросекундной длительности. Применение импульсного тока позволяет добиться существенного повышения эффективности процесса ЭХП, когда за счет локализации анодного растворения скорость сглаживания микронеровностей обрабатываемой поверхности, отнесенная к общему съему металла, значительно возрастает. Представлен сравнительный анализ режимов ЭХП с применением постоянного и импульсного тока на изменение шероховатости поверхности, съема, радиуса закругления кромок и коррозионной стойкости на примере стентов из коррозионностойкой стали 316LVM. По результатам выполненных

исследований установлены технологические режимы импульсного ЭХП, обеспечивающие наиболее качественное полирование поверхности стентов при малом съеме металла с незначительным скруглением кромок.

**Ключевые слова:** импульс тока, электрохимическое полирование, коронарный стент, электролит, эффективность сглаживания микронеровности, микронеровность

**Для цитирования:** Электрохимическое полирование матричных стентов из стали 316LVM с использованием микросекундных импульсов / Ю.Г. Алексеев [и др.] // Вест. Нац. акад. наук Беларуси. Сер. физ.-техн. наук. – 2021. – Т. 66, № 2. – С. 161–168. <https://doi.org/10.29235/1561-8358-2021-66-2-161-168>

**Introduction.** To increase the biological lumen and maintain the patency of the blood vessel after percutaneous transluminal angioplasty, stents are used in medical practice [1, 2]. Stents are made from implant materials widely used in medicine, such as nitinol, titanium, cobalt-chromium alloys, and corrosion-resistant steels. These materials combine high resistance to corrosion, strength, resilience, and radiopaque properties [3]. In this case, the most important property of stents, which has a significant effect on their corrosion resistance in an aggressive environment of the body, biocompatibility and the risk of a repeated decrease in the vessel lumen in the implantation zone, is the quality of their surfaces [3–7].

Currently, for the shaping of matrix-type stents, laser cutting from a tubular blank is used, the disadvantage of which is the formation of burrs, scale, and surface defects in the cut area [8]. The main part of the burr is preliminarily removed by mechanical methods and chemical etching [8–10]; to ensure a high quality of the surface of the stent ( $Ra$  up to 0.1  $\mu\text{m}$ ), electrochemical methods are used. Electrochemical polishing (ECP) of stents provides not only an improvement in the surface quality but also leads to the formation of a clean and uniform passive layer, the elimination of surface defects [11–14], an improvement in the mechanical properties of the treated surface and an increase in its corrosion resistance [3, 4, 6, 15–20]. In the production of stents from various implant materials, electrolytes and ECP modes are effectively used, which makes it possible to obtain a set of required performance characteristics. The processes of ECP developed to date for stents made of nitinol [7], corrosion-resistant steel [20, 21], titanium alloys [22, 23] provide high-quality polishing with a significant decrease in surface roughness and an increase in the corrosion resistance of the surface layer.

The main disadvantage of direct current ECP is excessive uncontrolled metal removal [25], which is especially unacceptable when processing small-section products such as stents. Another disadvantage is the need to use electrolytes of complex compositions containing a number of materials, including toxic components [25]. The use of a pulsed current makes it possible to achieve a significant increase in the efficiency of the ECP process, when, due to the localization of anodic dissolution, the rate of smoothing of microroughness of the treated surface, referred to the total metal removal, increases significantly. The duration of the pulses allows the influence on the thickness of the diffusion layer around the treated surface during the ECP process. Therefore, by changing the pulse duration, it becomes possible to control the rate of redox reactions and metal removal [25]. Thus, it becomes possible to high-quality polishing in electrolytes without the addition of toxic components such as fluorides, methanol and chromic anhydride. So, earlier in our work [26], it was established that the use of pulse modes in the process of ECP provides a significant decrease in surface roughness with a small removal of metal. The highest values of the efficiency of smoothing microroughness, defined as the ratio of the change in roughness  $\Delta Ra$  to metal mass  $\Delta m$  removal, are achieved for the bipolar pulse mode at a current density of  $i = 0.75 \text{ A/cm}^2$  and for a unipolar pulse mode at an anode current density of  $i_a = 1.0 \text{ A/cm}^2$ . The efficiency values obtained for pulsed modes are two times higher than the maximum efficiency (at  $i = 0.5 \text{ A/cm}^2$ ) for the traditional ECP using direct current. Accordingly, it is most advisable to use pulse modes for processing precision parts, products, or parts of small sections and rigidity (including stents), for which excessive metal removal from the treated surfaces is not allowed.

*The purpose of this work* is a comparative analysis of ECP modes with the use of direct and pulsed currents for changes in surface roughness, metal removal, changes in size, and corrosion resistance on the example of stents made of the 316LVM corrosion-resistant steel, as well as the establishment of technological ECP modes that provide the highest quality polishing of the surface with a relatively low metal removal and geometry changes (radius of curvature of edges).

**Materials, equipment, and research methods.** The studies were carried out on samples of coronal stents made of the 316LVM corrosion-resistant steel, obtained by laser cutting from drawn pipes with dimensions  $\varnothing 2.4 \times 0.2 \text{ mm}$  (Figure 1). The surface area of the stents is 3.8  $\text{cm}^2$ .

As a pretreatment before ECP to remove burr formed after laser cutting, acid etching was carried out in a solution of the composition HF (1 %), HNO<sub>3</sub> (9 %), and H<sub>2</sub>O (90 %) at 45 °C for 15 min in an ultrasonic bath. After acid etching, the stents were washed in water [27]. The roughness of the surface of the initial samples was *Ra* 0.22 μm.



Figure 1. The appearance of test samples

ECP of the samples was performed in an electrolyte of the following composition: 50 % – phosphoric acid, 25 % – sulfuric acid, 20 % – glycerol, 5 % – distilled water. The electrolyte temperature was maintained within 33 ± 5 °C. The required value of the current density was set by changing the voltage. To process the samples, we used experimental equipment consisting of an adjustable constant voltage source [29], a block of the system for forming pulses of a given duration, a bath with devices for heating, cooling, and stirring the electrolyte (Figure 2).



Figure 2. Experimental equipment for research

The measurement of the surface roughness of the samples before and after processing was carried out using an MII-4 micro interferometer. Electron microscopic photographs of the surface of the samples before and after processing were obtained on a VEGA II LMV scanning electron microscope. Optical photographs of the surface of thin sections of the samples before and after processing were obtained using an Altami MET1 metallographic microscope. The shape of the current pulses was monitored with an S8-46/1 oscilloscope. The mass was measured with an Ohaus PA214C weigh-scales. The control of corrosion resistance was carried out using a PI-50-Pro-3 pulse potentiostat-galvanostat in a 0.9 % sodium chloride solution.

For the treatment duration *t*, the values of 2, 4, 6, 8, 10, and 12 min were taken. The amplitude of current density for the pulsed ECP was 1.3 A/cm<sup>2</sup>, and for the ECP at a direct current was of 0.65 A/cm<sup>2</sup>. The accepted values of the current density ensure the equality of the amount of technological current for the investigated processes of pulsed ECP (PECP) and ECP at direct current (Figure 3). The duration of the no-current pause between pulses, equal to half of the period *T*, is compensated by twice the amplitude of the current *I*<sub>PECP</sub> at a pulsed ECP relative to the ECP on a direct current *I*<sub>ECP</sub>.

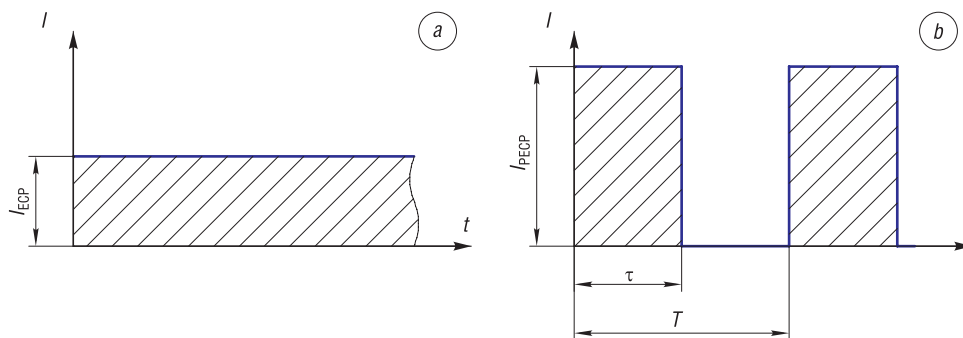

Figure 3. Diagrams of the shape of the pulses during ECP at a constant current (a) and pulse ECP (b)

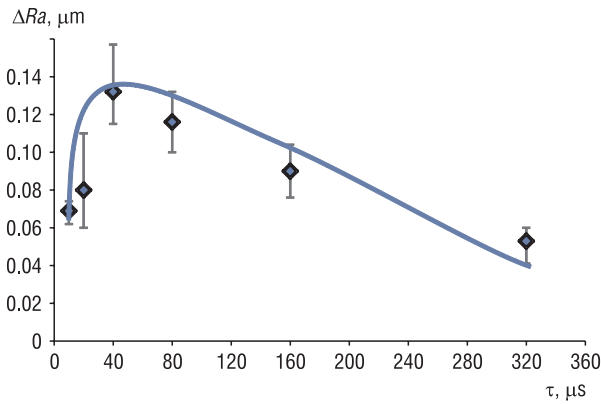

Figure 4. The effect of pulse duration in the process of pulsed ECP on the change in surface roughness of samples

**Results and discussion.** To establish the pulse duration that provides the best surface quality (the smallest surface roughness), the samples were preliminarily processed with the following characteristics:

- pulse duration  $\tau = 10, 20, 40, 80, 160$  and  $320 \mu\text{s}$ ;
- duty cycle  $S = 2$ ;
- peak current density of pulses  $i = 1.3 \text{ A/cm}^2$ ;
- processing time  $t = 8 \text{ min}$ .

The obtained dependence of the change in the surface roughness of the samples  $\Delta Ra$  on the pulse duration  $\tau$  during the pulsed ECT is shown in Figure 4. The maximum improvement in surface quality is observed at a pulse duration of  $40 \mu\text{s}$ . High processing quality at this value of the pulse

duration is achieved by creating the most favorable conditions under which comparable and high rates of anodic dissolution and surface passivation are provided, which makes it possible to completely remove dissolution products and restore the concentration of active components in the processing zone and ensure the maximum rate of smoothing of the surface microrelief with minimal material removal. Later in this work, when processing samples in the pulsed mode, the value of the pulse duration was taken to be  $40 \mu\text{s}$ .

Figure 5 shows the results of experimental studies of the effect of treatment duration  $t$  on the change in surface roughness and removal of stent material in the process of pulsed ECP and ECP at direct current. From the presented dependencies it can be seen that when using both the pulsed ECP mode and the traditional ECP using direct current, an approximately equal change in the roughness parameter  $Ra$  takes place. In this case, the removal of material  $\Delta m$  from the treated surfaces of the stent for the pulsed mode is, on average, 2.5 times less than for the constant current mode. Less removal with an equal amount of process current is explained by the passivation of the treated surface during the no-current pause between pulses. Accordingly, when a pulse following the pause occurs, electrochemical dissolution does not begin instantly, but with a certain delay, commensurate with the duration of the acting pulse, which has the main effect on the extraction. Intensive smoothing of the microrelief at low metal removal in the pulsed mode is associated with the accelerated dissolution of primarily polarized microprotrusions on the treated surface as compared to passivated micro depressions.

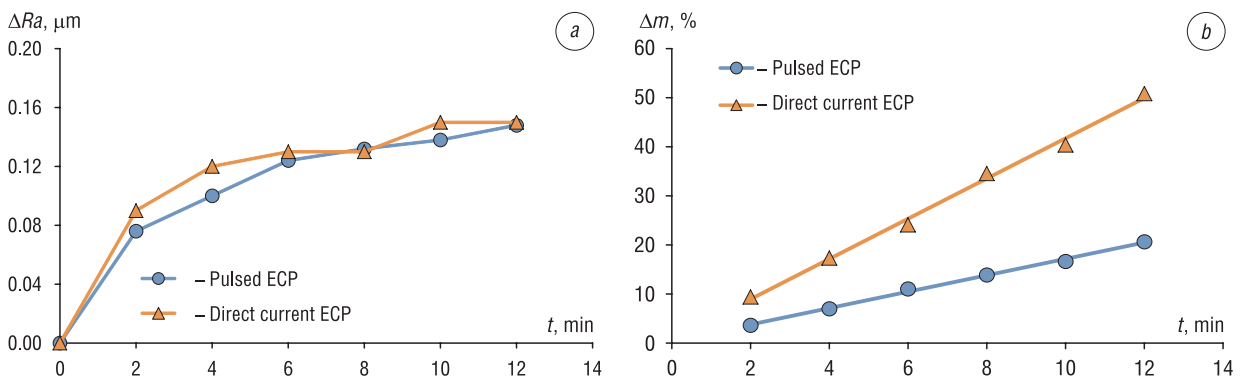

Figure 5. The effect of the processing time on the change in surface roughness (a) and material removal (b) of the samples during pulsed ECP and ECP on a direct current

Quantitatively, the efficiency of ECP of stent surfaces using a pulsed mode can be estimated by the ratio of the achieved change in roughness to the mass of metal removed during processing. As shown in Figure 6 of the diagram, it can be seen that in general, both for the pulsed mode and for the mode at constant current, with an increase in the duration, the processing efficiency decreases. At the same time, the efficiency of ECP with the use of the pulsed mode is on average 2.3 times higher than with the traditional ECP using direct current.

In the process of stent implantation using a high-pressure balloon (up to 12 atm), there is a possibility of vascular wall perforation. Therefore, the edges of the stent frame elements must be rounded [31]. On the other hand, excessive rounding of the edges, along with a decrease in the cross-section of the frame elements, leads to a significant decrease in the stiffness of the stent and, accordingly, to the loss of its ability to reinforce the vascular wall. In modern stent production processes, the main edge rounding is provided by shot blasting, prior to electrochemical polishing [5]. Therefore, directly at the stage of electrochemical polishing, significant rounding of the edges is undesirable (more than 20 microns). The use of the pulsed mode allows reducing of the rounding of edges during the polishing of stents (Figure 7). The value of the radius of rounding of the edges  $r$  after processing in the pulsed mode is on average 15 % less than when processing with direct current. This is achieved due to significantly less metal removal in the process of pulsed ECP compared to DC ECP.

From those presented in Figures 5–7 experimental dependencies, it follows that to ensure a high quality of the stents surface under the condition of small removal with a slight rounding of the edges (10–15  $\mu\text{m}$ ), the required duration of the pulse ECP is 6–8 min.

Figure 8 shows polarization curves obtained in 0.9 % sodium chloride solution for initial stent samples and stent samples after pulsed ECP and direct current ECP for 6 min. It was found that the type of technological current used in the process of ECP of stents does not affect the protective properties of the surface. Pulsed ECP, as well as traditional ECP using direct current, leads to a significant increase in the pitting potential  $\phi$  of the studied stent samples – from 770 to 1370 mV.

Micrographs of the initial stent samples and samples after a 6-min pulse ECP are shown in Figure 9. The surface of the original stent samples is characterized by the presence of scratches and other defects formed as a result of preliminary mechanical, sandblasting, and chemical etching. The edges have laser-cut burrs. As a result of the pulsed ECP, the relief of microroughness is smoothed out, and a smooth surface that does not contain defects is formed. In this case, the rounding of the edges is insignificant (10–15  $\mu\text{m}$ ).

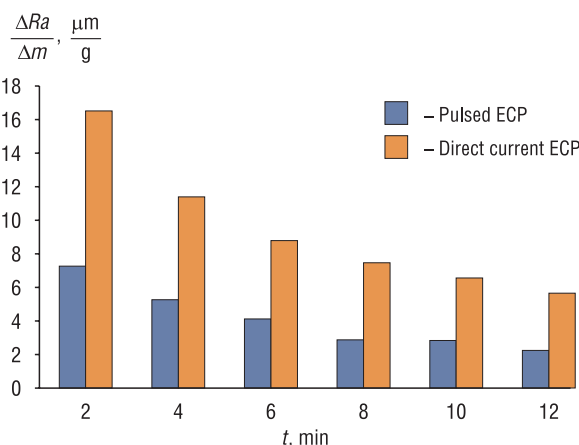

Figure 6. Change in the efficiency of the processing time with pulsed ECP and ECP on direct current

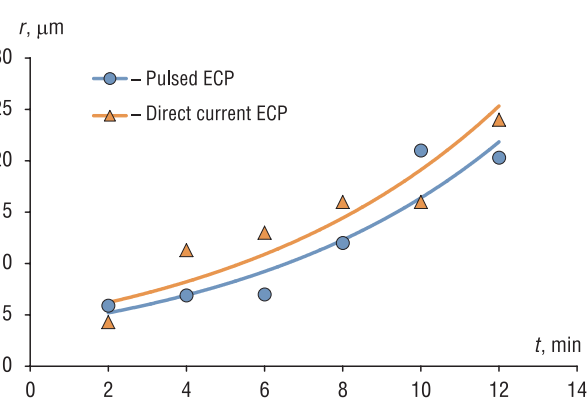

Figure 7. The influence of the processing time on the change in the radii of rounding of the edges of the stents

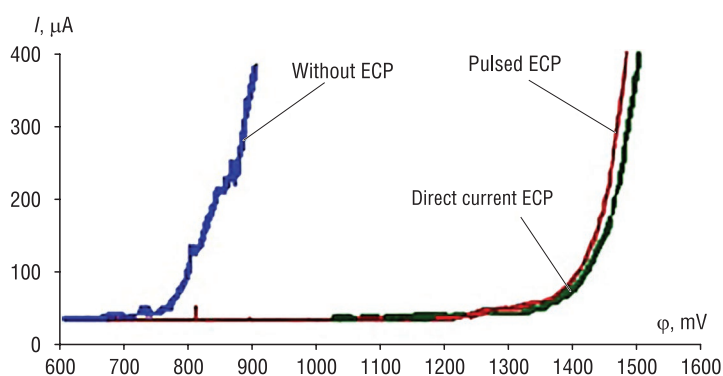

Figure 8. The effect of pulsed ECP and ECP on direct current on the change in the potential of the pitting surface of the stents

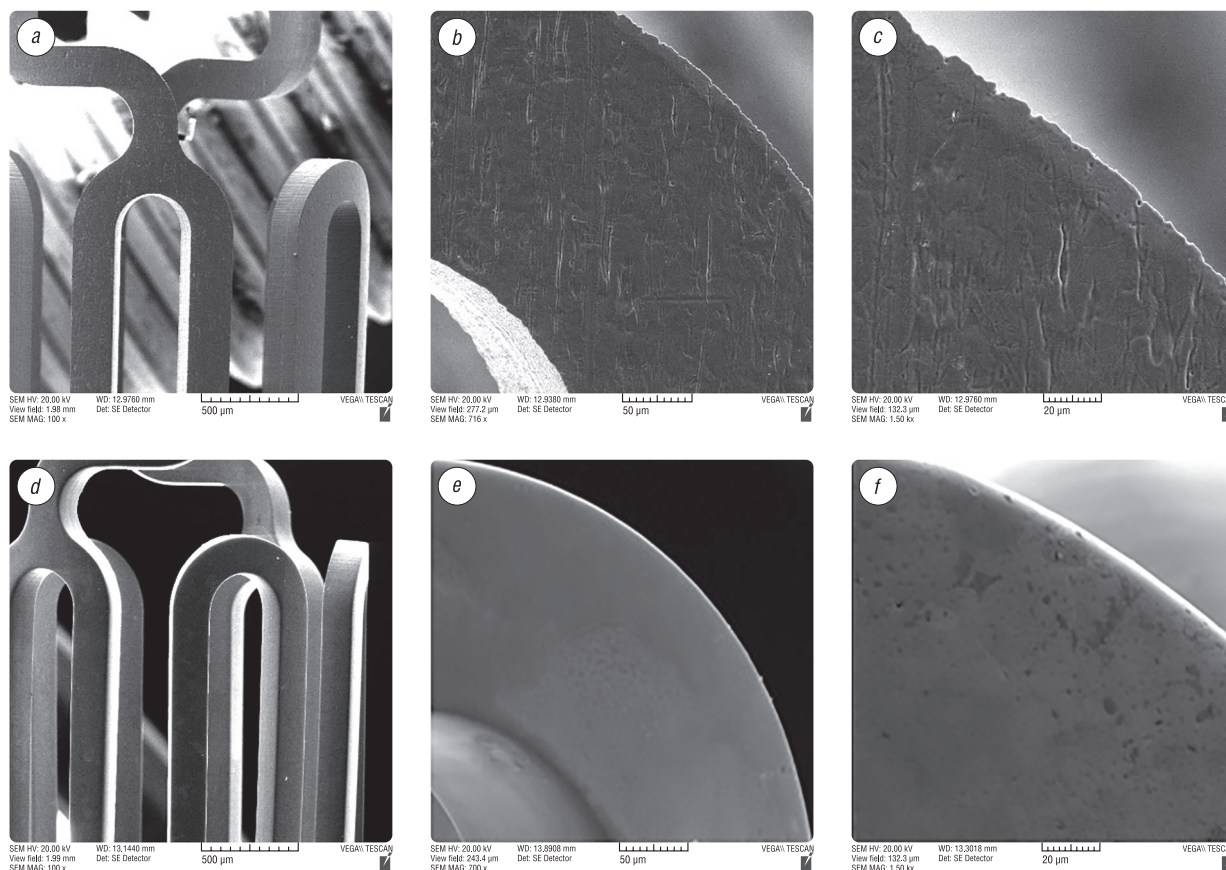

Figure 9. Microphotographs of stents before (a, b, c) and after processing (d, e, f) pulsed ECP application

**Conclusion.** The use of pulsed modes in the process of ECP for products of small cross-section and stiffness, for which excessive metal removal is not allowed, such as coronary stents, allows high-quality surface finishing with high efficiency, at which the intensity of smoothing the microroughness of the treated surface, referred to the total metal removal, increases significantly in comparison with traditional ECP using direct current. The efficiency of ECP in the pulsed mode is, on average, 2.3 times higher than with traditional ECP using direct current.

According to the results of the studies performed, it was found that the high quality of the surface of stents made of the 316LVM corrosion-resistant steel under the condition of low removal (11–14 %) with a slight rounding of the edges is achieved in the process of a pulsed ECP with a pulse duration of 40  $\mu\text{s}$ , a current density of 1.3  $\text{A}/\text{cm}^2$  with a duration processing 6–8 min. Processing with such characteristics leads to an improvement in the surface roughness  $R_a$  of 0.12–0.13  $\mu\text{m}$ , the formation of a smooth surface, the removal of scale and burrs formed during laser cutting, as well as an increase in the pitting potential in comparison with the initial state from 770 to 1370 mV.

## References

1. Hill R. A., Dunder Y., Bakhai A., Dickson R., Walley T. Drug-eluting stents: an early systematic review to inform policy. *European Heart Journal*, 2004, vol. 25, no. 11, pp. 902–919. <https://doi.org/10.1016/j.ehj.2004.03.023>
2. Colombo A., Iakovou I. Drug-eluting stents: the new gold standard for percutaneous coronary revascularization. *European Heart Journal*, 2004, vol. 25, no. 11, pp. 895–897. <https://doi.org/10.1016/j.ehj.2004.04.004>
3. Mani G., Feldman M. D., Patel D., Agrawal C. M. Coronary stents: a materials perspective. *Biomaterials*, 2007, vol. 28, no. 9, pp. 1689–1710. <https://doi.org/10.1016/j.biomaterials.2006.11.042>
4. Sojitra P., Engineer C., Kothwala D. M., Raval A. Electropolishing of 316LVM stainless steel cardiovascular stents: an investigation of material removal, surface roughness and corrosion behavior. *Trends in Biomaterials and Artificial Organs*, 2010, vol. 23, no. 3, pp. 115–121.
5. Gellér Z. E., Albrecht K., Dobránszky J. Electropolishing of coronary. *Materials Science Forum*, 2008, vol. 589, pp. 367–372.

6. Ji Shi-wei, Nan H., Guo-Jiang W., Kai W. Electrochemical polishing of 316L stainless steel stent. *Journal of Clinical Rehabilitative Tissue Engineering Research*, 2011, vol. 15, no. 16, pp. 2851–2854.
7. Kim J., Park J. K., Kim H. K., Unnithan A. R. Optimization of electropolishing on NiTi alloy stents and its influence on corrosion behavior. *Journal of Nanoscience and Nanotechnology*, 2017, vol. 17, no. 4, pp. 2333–2339. <https://doi.org/10.1166/jnn.2017.13324>
8. Chen J. H., Yang D. Z., Liu J. X., et al. The research progress of corrosion resistance of metallic implants. *Materials Science and Engineering*, 2002, vol. 18, no. 4, pp. 130–134.
9. Munroe N., Pulletikurthi C., Haider W. Enhanced biocompatibility of porous nitinol. *Journal of Materials Engineering and Performance*, 2009, vol. 18, no. 5–6, pp. 765–767. <https://dx.doi.org/10.1007/s11665-009-9454-2>
10. Shabalovskaya S. A., Andereg J., Van Humbeeck J. Critical overview of nitinol surfaces and their modifications for medical applications. *Acta Biomaterialia*, 2008, vol. 4, pp. 447–467. <https://doi.org/10.1016/j.actbio.2008.01.013>
11. Simka W., Kaczmarek M., Baron-Wiecheć A., Nawrat G., Marciniak J., Zak J. Electropolishing and passivation of NiTi shape memory alloy. *Electrochimica Acta*, 2010, vol. 55, no. 7, pp. 2437–2441. <https://doi.org/10.1016/j.electacta.2009.11.097>
12. Wong M. H., Cheng F. T., Man H. C. Comparison of corrosion resistance and apatite-forming ability of NiTi treated by different low-temperature methods. *Journal of Alloys and Compounds*, 2008, vol. 466, L5–L10. <https://doi.org/10.1016/j.jallcom.2007.11.077>
13. Michiardi A., Aparicio C., Planell J., Gil F. Electrochemical behavior of oxidized NiTi shape memory alloys for biomedical applications. *Surface and Coatings Technology*, 2007, vol. 201, no. 14, pp. 6484–6488. <https://doi.org/10.1016/j.surfcoat.2006.12.023>
14. Robertson S. W., Pelton A. R., Ritchie R. O. Mechanical fatigue and fracture of Nitinol. *International Materials Reviews*, 2012, vol. 57, no. 1, pp. 1–36. <https://doi.org/10.1179/1743280411y.0000000009>
15. Vojtěch D., Voděrová M., Kubásek J., Novák P., Šedá P., Michalcová A., Fojt J., Hanuš J., Mestek O. Effects of short-time heat treatment and subsequent chemical surface treatment on the mechanical properties, low-cycle fatigue behavior and corrosion resistance of a Ni–Ti (50.9 at.% Ni) biomedical alloy wire used for the manufacture of stents. *Materials Science and Engineering: A*, 2011, vol. 528, pp. 1864–1876. <https://doi.org/10.1016/j.msea.2010.10.043>
16. Thierry B., Tabrizian M., Trepanier C., Savadogo O., Yahia L. H. Effect of surface treatment and sterilization processes on the corrosion behavior of NiTi shape memory alloy. *Journal of Biomedical Materials Research*, 2000, vol. 51, pp. 685–693. [https://doi.org/10.1002/1097-4636\(20000915\)51:4<685::aid-jbm17>3.0.co;2-s](https://doi.org/10.1002/1097-4636(20000915)51:4<685::aid-jbm17>3.0.co;2-s)
17. Rokicki R. Magnetic field and electropolished metallic implants. *Medical Device & Diagnostic Industry*, 2006, vol. 28, no. 3, pp. 116–123.
18. Hryniewicz T., Rokicki R., Rokosz K. Corrosion characteristic of medical grade AISI 316L stainless steel surface after electropolishing in magnetic field. *The Journal of Corrosion Science and Engineering*, 2007, vol. 10, no. 45, pp. 1–10.
19. Hryniewicz T., Rokosz K., Rokicki R. Electrochemical and XPS Studies of AISI 316L Stainless Steel after Electropolishing in a Magnetic Field. *Corrosion Science*, 2008, vol. 50, no. 9, pp. 2676–2681. <https://doi.org/10.1016/j.corsci.2008.06.048>
20. Scheerder I. D., Sohler J., Froyen L., Humbeeck J. V., Verbeken E. Biocompatibility of coronary stent materials: effect of electrochemical polishing. *Materialwissenschaft und Werkstofftechnik*, 2001, vol. 32, no. 2, pp. 142–148. [https://doi.org/10.1002/1521-4052\(200102\)32:2<142::aid-mawe142>3.0.co;2-n](https://doi.org/10.1002/1521-4052(200102)32:2<142::aid-mawe142>3.0.co;2-n)
21. Mei Yu, Junlan Yi, Jianhua Liu, Songmei Li. Effect of electropolishing on electrochemical behaviours of titanium alloy Ti-10V-2Fe-3Al. *Journal Wuhan University of Technology, Materials Science Edition*, 2011, vol. 26, no. 3, pp. 469–477. <https://doi.org/10.1007/s11595-011-0251-z>
22. Biswas C. K., Bayagoob A. Y., Hussain P. bin. Electrochemical polishing of titanium alloys with ionic. *National Institute of Technology*, 2008, vol. 589, pp. 367–372.
23. Birch M. A., Johnson-Lynn S., Nouraei S., Q-B Wu, Ngalm S., W-J Lu, Watchorn C., T-Y Yang, Mccaskie A. W., Roy S. Effect of electrochemical structuring of Ti6Al4V on osteoblast behaviour *in vitro*. *Biomedical Materials*, 2012, vol. 7, no. 3, art. 035016. <https://doi.org/10.1088/1748-6041/7/3/035016>
24. Bhuyan A., Gregory B., Lei H., Yee S. Y., Gianchandani Y. B. Pulse and DC electropolishing of stainless steel for stents and other devices. *IEEE Sensors*, 2005, pp. 314–317. <https://doi.org/10.1109/icsens.2005.1597699>
25. Morales A. L., McCrabb H., Miller Ph., Inman M., Taylor E. J. Electrochemical finishing of small part components: Alternative technique holds promise for complex electronics finishing applications. *Faraday Technology*, 2008, vol. 106, no. 3, pp. 27–31. [https://doi.org/10.1016/S0026-0576\(08\)80056-6](https://doi.org/10.1016/S0026-0576(08)80056-6)
26. Alekseev Yu. G., Korolev A. Yu., Niss V. S., Parshuto A. E., Budnitskii A. S. Application of pulse modes in electrochemical polishing of corrosion-resistant steels. *Nauka i tekhnika = Science & Technique*, 2019, vol. 18, no. 3, pp. 200–209 (in Russian). <https://doi.org/10.21122/2227-1031-2019-18-3-200-208>
27. Raval A., Choubey A., Engineer Ch., Kothwala D. J. Surface conditioning of 316LVM slotted tube cardiovascular stents. *Applied Microbiology and Biotechnology*, 2005, vol. 19, no. 3, p. 197. <https://doi.org/10.1177/0885328205046564>
28. Guo X. L., Yi X. Studies on electrochemical polishing of stainless steel. *Electroplating Finishing*, 2001, vol. 20, no. 5, pp. 11–13.
29. Alekseev Yu. G., Korolev A. Yu., Niss V. S., Parshuto A. E., Soroka E. V., Budnitskii A. S. Power supply for the study of pulsed electrochemical processes. *Energetika. Izvestiya vysshikh uchebnykh zavedenii energeticheskikh ob"edinenii SNG = ENERGETIKA. Proceedings of CIS higher education institutions and power engineering associations*, 2018, no. 3, pp. 246–257 (in Russian). <https://doi.org/10.21122/1029-7448-2019-61-3-246-257>
30. Galanin S. I., Kalinnikov I. V., Galanina A. S. Technological features of electrochemical polishing of gold alloys by pulse currents. *Surface Engineering and Applied Electrochemistry*, 2009, vol. 45, no. 2, pp. 85–92. <https://doi.org/10.3103/S1068375509020021>
31. Qing-Hai H., Zou Z., Yongwei Zh., Rui Zh. Vascular perforation by enterprise stent during stent-assisted coil embolization for intracranial aneurysm. *Cardiovascular and Interventional Radiology*, 2012, vol. 36, no. 3, pp. 857–859. <https://doi.org/10.1007/s00270-012-0443-8>

### Information about the authors

*Yury G. Aliakseyeu* – Ph. D. (Engineering), Assistant Professor, General Manager – Vice-Rector on Production Activity, Scientific and Technological Park BNTU “Polytechnic” (24, Ya. Kolas Str., 220013, Minsk, Republic of Belarus). <https://orcid.org/0000-0002-1582-004X>. E-mail: [alekseev@icm.by](mailto:alekseev@icm.by)

*Aleksandr Yu. Korolyov* – Ph. D. (Engineering), Assistant Professor, Head of Prospective Technologies Department, Scientific and Technological Park BNTU “Polytechnic” (24, Ya. Kolas Str., 220013, Minsk, Republic of Belarus). <https://orcid.org/0000-0002-0841-1272>. E-mail: [korolyov@park.bntu.by](mailto:korolyov@park.bntu.by)

*Vladimir S. Niss* – Ph. D. (Engineering), Assistant Professor, Head of the Innovation and Production Center of Medical Equipment and Products, Belarusian National Technical University (65, Nezavisimosti Ave., 220013, Minsk, Republic of Belarus). <https://orcid.org/0000-0003-2773-0110>. E-mail: [niss@park.bntu.by](mailto:niss@park.bntu.by)

*Alexey S. Budnitskiy* – Junior Researcher, Scientific and Technological Park BNTU “Polytechnic” (24, Ya. Kolas Str., 220013, Minsk, Republic of Belarus). <https://orcid.org/0000-0002-6022-7448>. E-mail: [budnitskiy@park.bntu.by](mailto:budnitskiy@park.bntu.by)

### Информация об авторах

*Алексеев Юрий Геннадьевич* – кандидат технических наук, доцент, генеральный директор – проректор по производственной деятельности, Научно-технологический парк БНТУ «Политехник» (ул. Я. Коласа, 24, 220013, Минск, Республика Беларусь). <https://orcid.org/0000-0002-1582-004X>. E-mail: [y.aliakseyeu@bntu.by](mailto:y.aliakseyeu@bntu.by)

*Королев Александр Юрьевич* – кандидат технических наук, доцент, заведующий научно-исследовательским сектором перспективных технологий, Научно-технологический парк БНТУ «Политехник» (ул. Я. Коласа, 24, 220013, Минск, Республика Беларусь). <https://orcid.org/0000-0002-0841-1272>. E-mail: [korolyov@park.bntu.by](mailto:korolyov@park.bntu.by)

*Нисс Владимир Семенович* – кандидат технических наук, доцент, заведующий инновационно-производственным центром медицинского оборудования и изделий, Белорусский национальный технический университет (пр. Независимости, 65, 220013, Минск, Республика Беларусь). <https://orcid.org/0000-0003-2773-0110>. E-mail: [niss@park.bntu.by](mailto:niss@park.bntu.by)

*Будницкий Алексей Сергеевич* – младший научный сотрудник, Научно-технологический парк БНТУ «Политехник» (ул. Я. Коласа, 24, 220013, Минск, Республика Беларусь). <https://orcid.org/0000-0002-6022-7448>. E-mail: [budnitskiy@park.bntu.by](mailto:budnitskiy@park.bntu.by)