

FT spectroscopy in support of atmospheric spectroscopic databases: Recent advances at DLR

Georg Wagner, Manfred Birk, Christian Röske
Remote Sensing Technology Institute, DLR

HRMS 2021, Cologne

Knowledge for Tomorrow



- Since 1990 high resolution spectroscopy for spectroscopic databases of atmospheric constituents
- Commercial Bruker IFS125 HR FT spectrometer 10-40000 cm^{-1}



Single pass cell

- 22 cm absorption path, accuracy 0.1%
- 190-350 K temperature range
- 0.1 K temperature homogeneity
- Operated inside evacuated Bruker IFS
125 HR sample compartment
- 2 window pairs for multicolor measurements

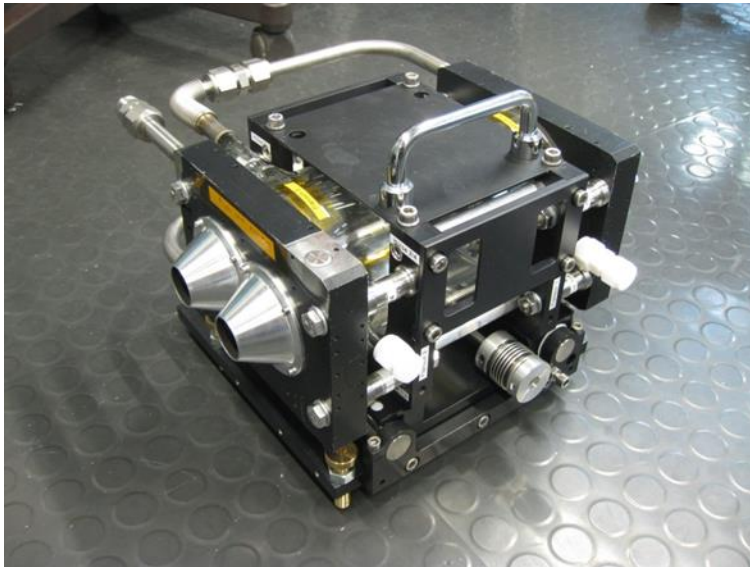
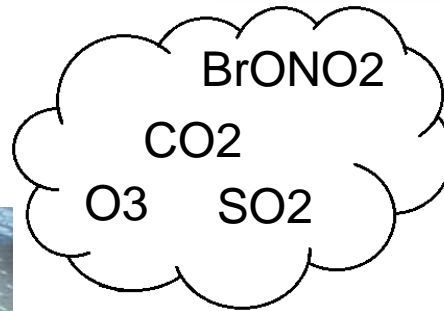
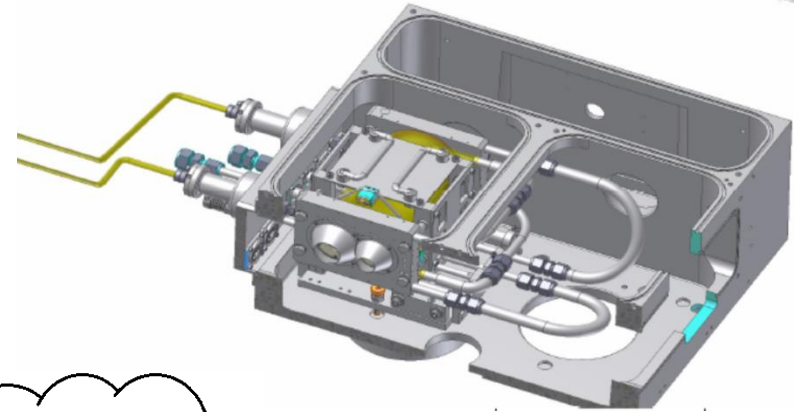

Multireflection cell

- 14-165 m absorption path, accuracy 0.1%
- 190-350 K temperature range
- Mirrors actively thermalized
- 0.1 K temperature homogeneity
- Attached to Bruker IFS 125 HR
- Transfer optics in sample chamber
- Mirror coating selected for minimum reflection loss

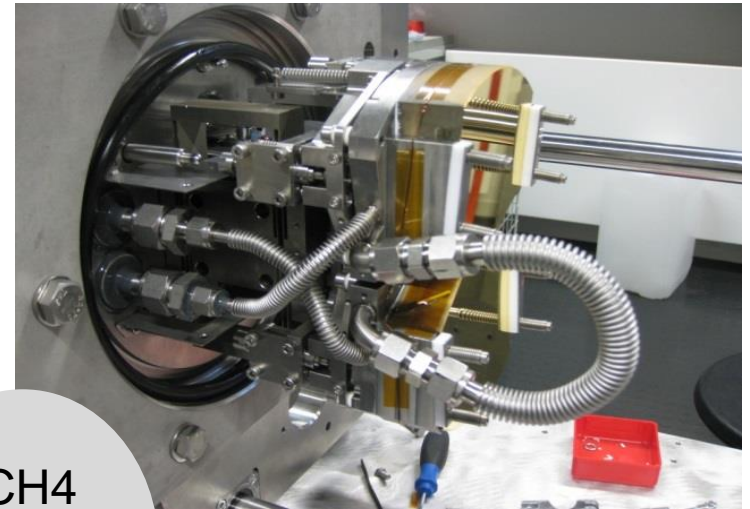
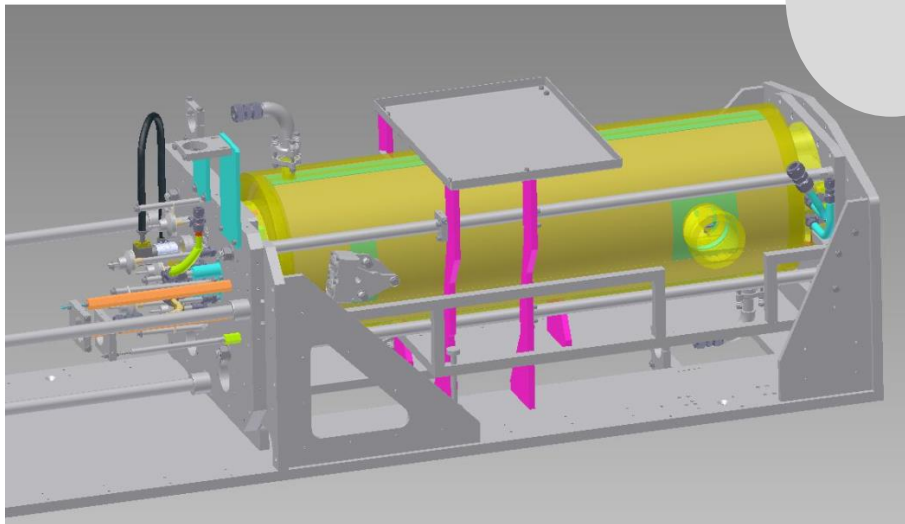

CH₄
H₂O
CO
CO₂



Other infrastructure: Gas handling

- Precision pressure transducers: mks Baratron 0.05% accuracy
- Temperature sensors: Lakeshore Pt100, 0.1 K accuracy
- 800 l stainless steel gas mixing chamber, stirrer
- Flow and pressure controllers



Other infrastructure: Interferometer alignment

- Dedicated Hardware for interferometer alignment for optimal instrumental line shape (ILS)
 - HeNe laser with two consecutive scattering surfaces for appropriate field-of-view illumination
 - CCD camera for Haidinger fringe recording
 - Haidinger fringes can be recorded with evacuated spectrometer
- ILS characterisation with linefit software by Frank Hase, IMK

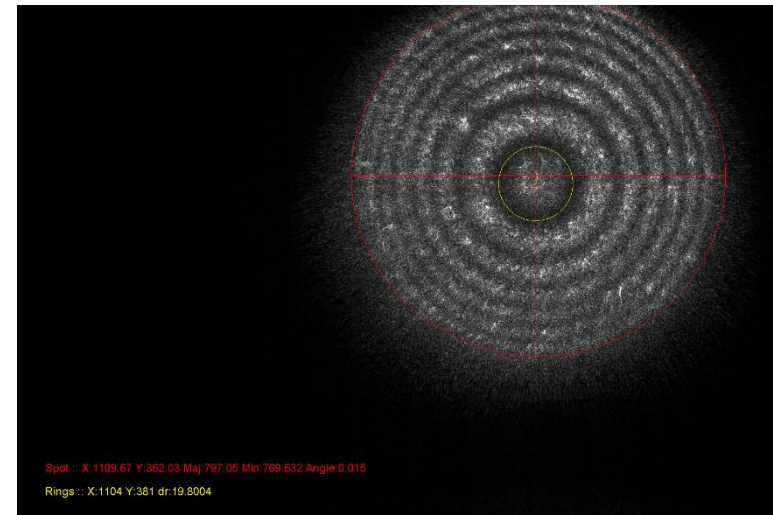
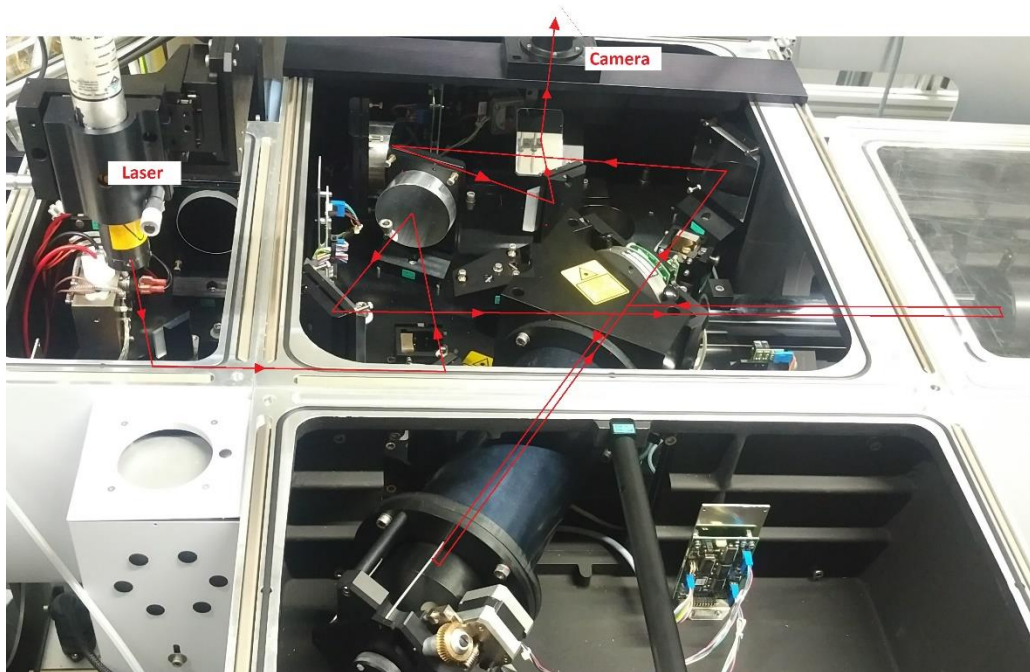

Other infrastructure: Multireflection cell

- Dedicated raytracing tool for marginal rays: Source \Rightarrow interferometer \Rightarrow **multireflection cell** \Rightarrow detector
- Adjustment multireflection cell: Camera for observation of **spot pattern on T-mirror**
- Camera at detector exit of spectrometer to visualise image on detector

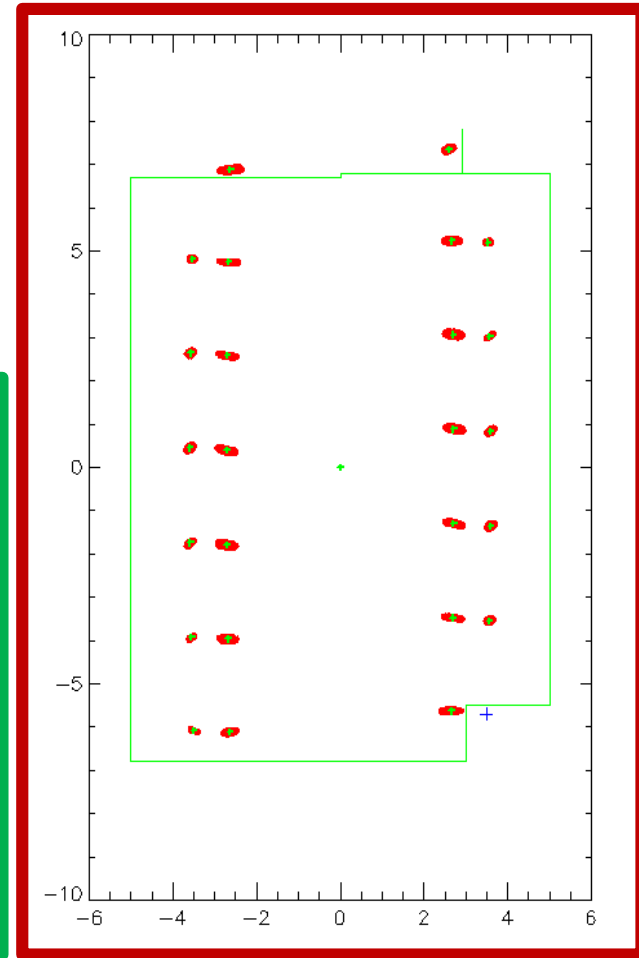
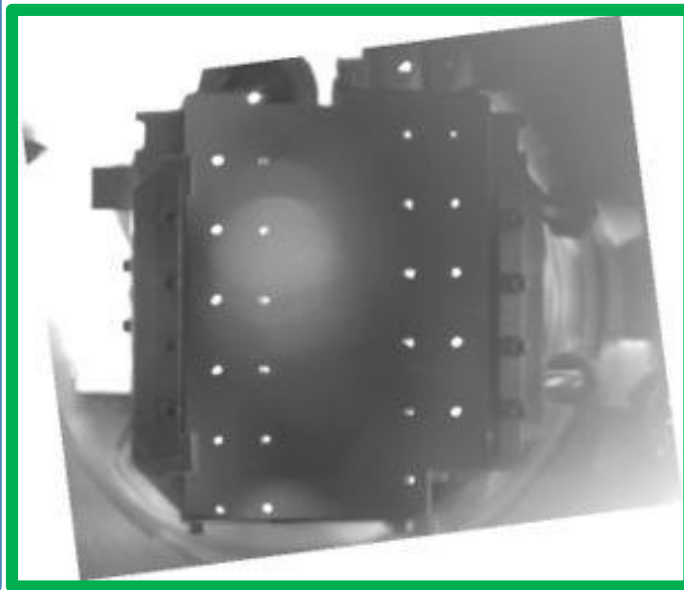
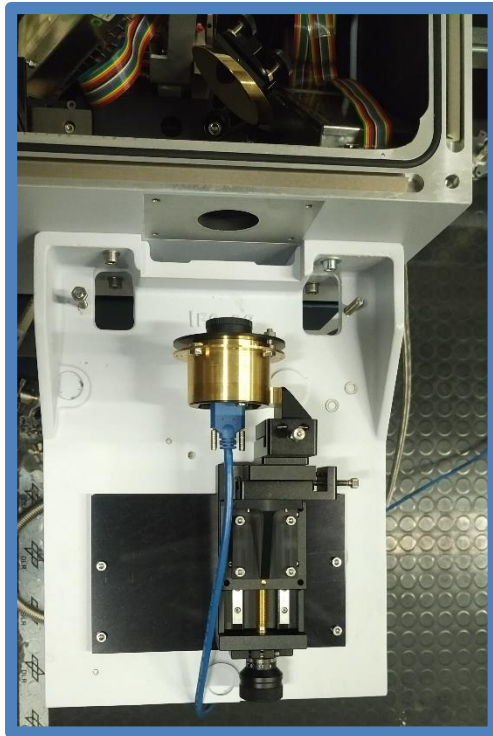

Software tools

- Correction of detector non-linearities
- Correction of thermal emission of radiation of sample and spectrometer
- Development of line fitting software
 - INTMET/INTBAT adapted from John W. Johns, NRC, Ottawa, Canada
 - FitMAS by Franz Schreier, DLR, Germany
 - Multispectrum fit by Joep Loos, DLR, Germany
- Multispectrum fitting software for absorption cross sections



Multispectrum fitting software

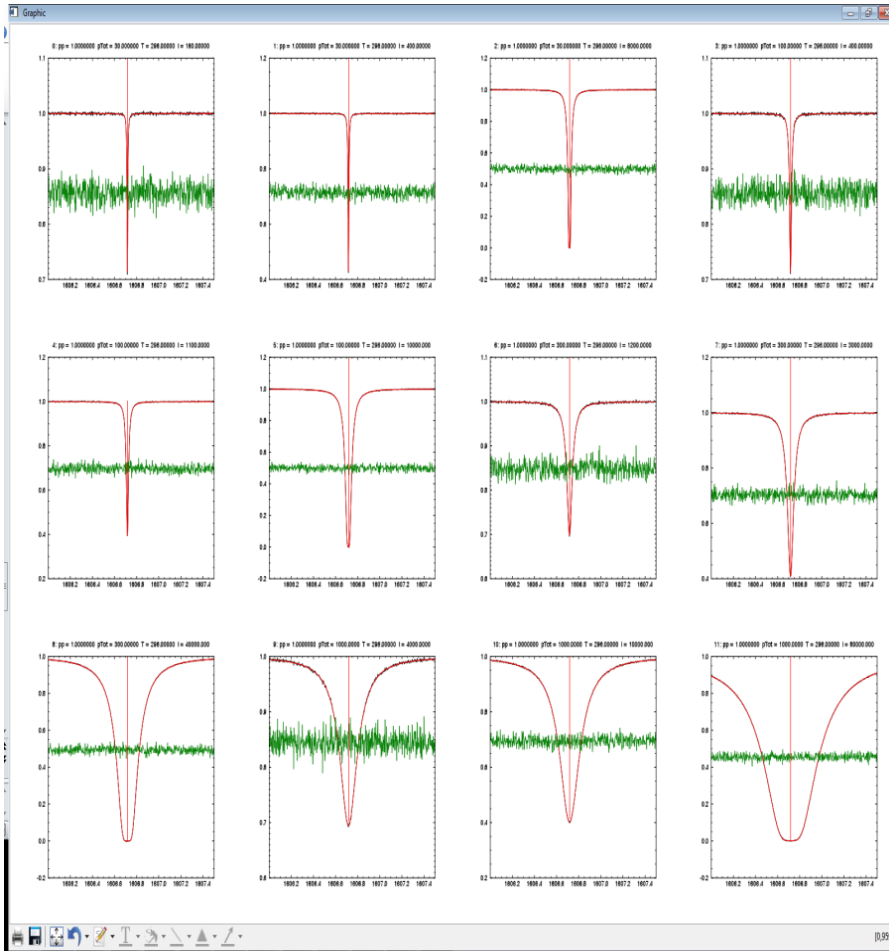
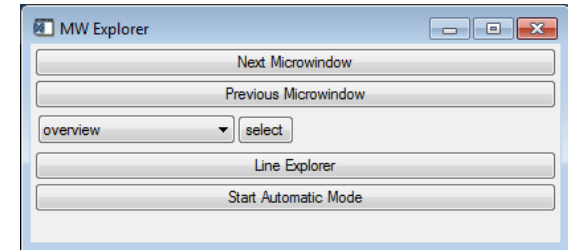

Line Explorer

GLOBAL PREFERENCES #1

Select spectra

0 1 2 3 4 5 6 7 8 9 10 11

all none

SPECTRA PREFERENCES

Spectrum 0 Spectrum 1 Spectrum 2 Spectrum 3 Spectrum 4 Spectrum 5 Spectrum 6 Spectrum 7

of baseline parameters: 0

Fit Channelling A: 0.0000000 T: 1.0000000 maxWN: 1606.7500

fit cal factor

ILS: sincBox

GLOBAL PREFERENCES #2

Fit rises (only when sincBox is selected)

1.2650000

1.2650000

Start Fit

fit OK

Residue Factor: x10

Plot Absorption

LINE PREFERENCES

0

11 1606.716310 1.036E-21 9.408E-02 09180.450 447.25240 720.001040

line profile: Speed-dependent Voigt

select parameters for SDV fit of line: 0

<input checked="" type="checkbox"/> sigma	1606.7163	5.0552128e-006	0.0000 %
<input type="checkbox"/> S	1.0360000e-021	0.000000000	0.0000 %
<input checked="" type="checkbox"/> gamma0_air	0.091812379	4.5797314e-005	0.0499 %
<input checked="" type="checkbox"/> gamma2_air	0.013911432	0.00018493259	1.3291 %
<input type="checkbox"/> eta0_air	0.0010400000	0.000000000	0.0000 %
<input type="checkbox"/> eta2_air	0.000000000	0.000000000	NaN %
<input type="checkbox"/> delta0_air	0.000000000	0.000000000	NaN %
<input type="checkbox"/> n_air	0.720000000	0.000000000	0.0000 %
<input type="checkbox"/> gamma0_self	0.450000000	0.000000000	0.0000 %
<input type="checkbox"/> gamma2_self	0.000000000	0.000000000	NaN %
<input type="checkbox"/> eta0_self	0.0010400000	0.000000000	0.0000 %
<input type="checkbox"/> eta2_self	0.000000000	0.000000000	NaN %
<input type="checkbox"/> delta0_self	0.000000000	0.000000000	NaN %
<input type="checkbox"/> n_self	0.720000000	0.000000000	0.0000 %

Automatic parameter selection SET Initial Para

equal gamma2

equal eta0

equal eta2

equal delta0

equal n



Absorption cross section multispectrum fitting

- Example of multispectrum fitting for BrONO₂ absorption cross sections
- Absorption cross sections calculated for each measurement
- 2D polynomial fit ($\ln(p+5 \text{ mbar})$: 3rd order + T: 2nd order) + baseline polynomials + scaling factors

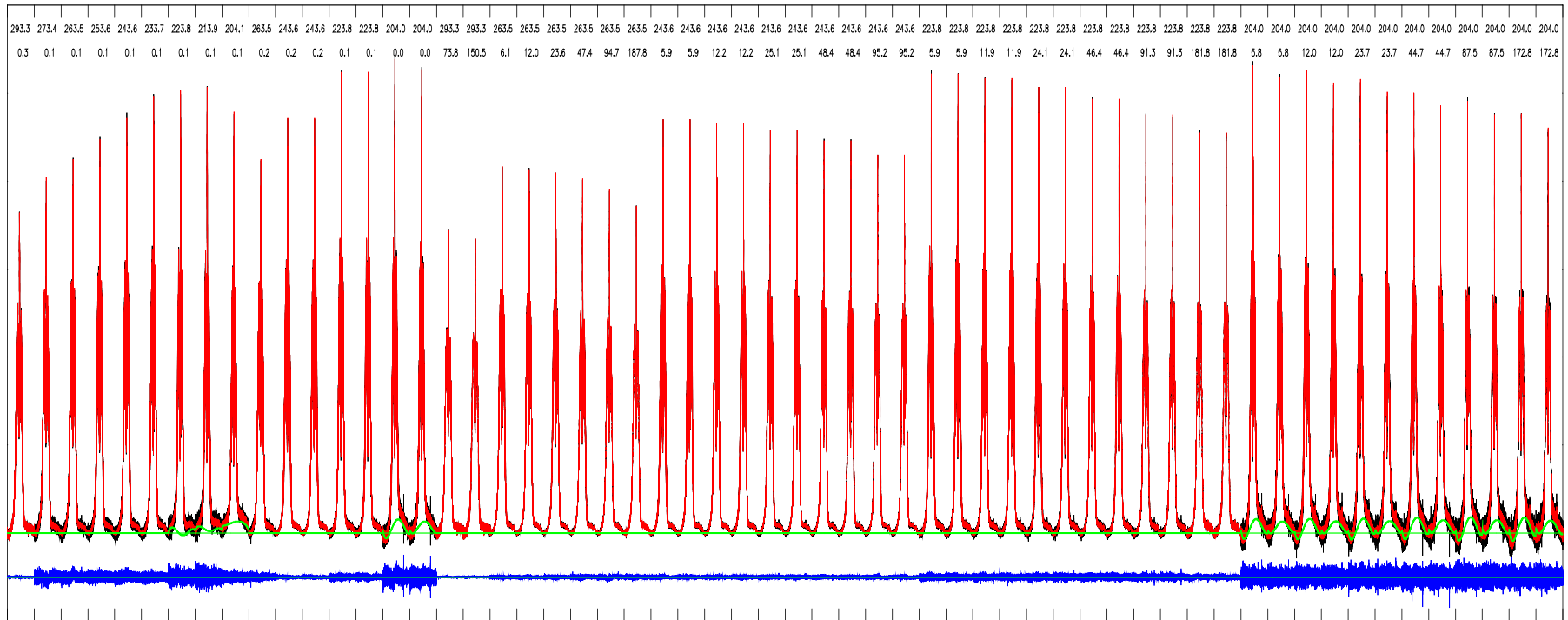

Measurements at DLR

Molecule	Spectral region	Type of data	HITRAN issue
ClONO2	690-1330	Cross sections (p,T)	2004
ClOCl	500-835	Cross sections (T)	2012
N2O5	540-1380	Cross sections (T)	2004
ClO	800	Line intensities	2012
ClO	FIR	Air broadening parameters	2000
HOCl	FIR	Line positions + intensities	2004
H2O	10000-11000	Line intensities	2012
H2O	1250-1750	Line intensities	2008+2012
H2O	1250-1750	air + self broadening parameters	2012
H2O	1850-4000	Line positions, line intensities, air+self HTP parameters + line mixing	2016
H2O	4190-4340	Line positions, line intensities	2016
H2O	4190-4340	Air+self HTP parameters + line mixing	2020

Molecule	Spectral region	Type of data	HITRAN issue
H2O	3400-3900	Self and foreign continuum	
O3	600-1200	Line intensities, air broadening parameters	2004
O3	600-1200	Line positions, line intensities, air broadening parameters, air shifts	2020
O3	28000-42000	Cross sections (T)	2020
SO2	23000-36000	Cross section (T)	2020
N2O	2180-2255	HTP parameters + line mixing	2016
BrONO2	675-1400	Cross sections (p,T)	2016
CO2	2250-2400	HTP parameters + line mixing	2020
CO2	6000-7000	Line positions, line intensities, self HTP parameters + line mixing	2020
CH4	4190-4340	Line positions, line intensities, HTP parameters + line mixing	2020



Accuracy requirements for spectroscopic parameters

- Initially spectroscopic database for stratospheric ozone relevant species
- Recently focus on climate-relevant species with high accuracy requirement down to 0.1% level
- Rigorous investigations of spectroscopic parameter accuracy requirements related to satellite data product requirements are rather rare
- DLR extended expertise to perform retrieval simulations to deduce spectroscopic parameter requirements from satellite atmospheric data product requirements, e.g. CO₂ or CH₄ column amounts
- These simulations were carried out in combination with dedicated spectroscopic database projects
- Examples: CH₄, CO, (H₂O) for S5P, CH₄, (H₂O) for Merlin, CO₂, O₂, CH₄ (H₂O) for CO2M



CO2M differential error on CO2 column: <0.1%

- Example: Modelled spectrum CO2M CO2 strong band, subarctic winter atmosphere, airmass 3. In retrieval line mixing omitted. Residuals x100 in blue.

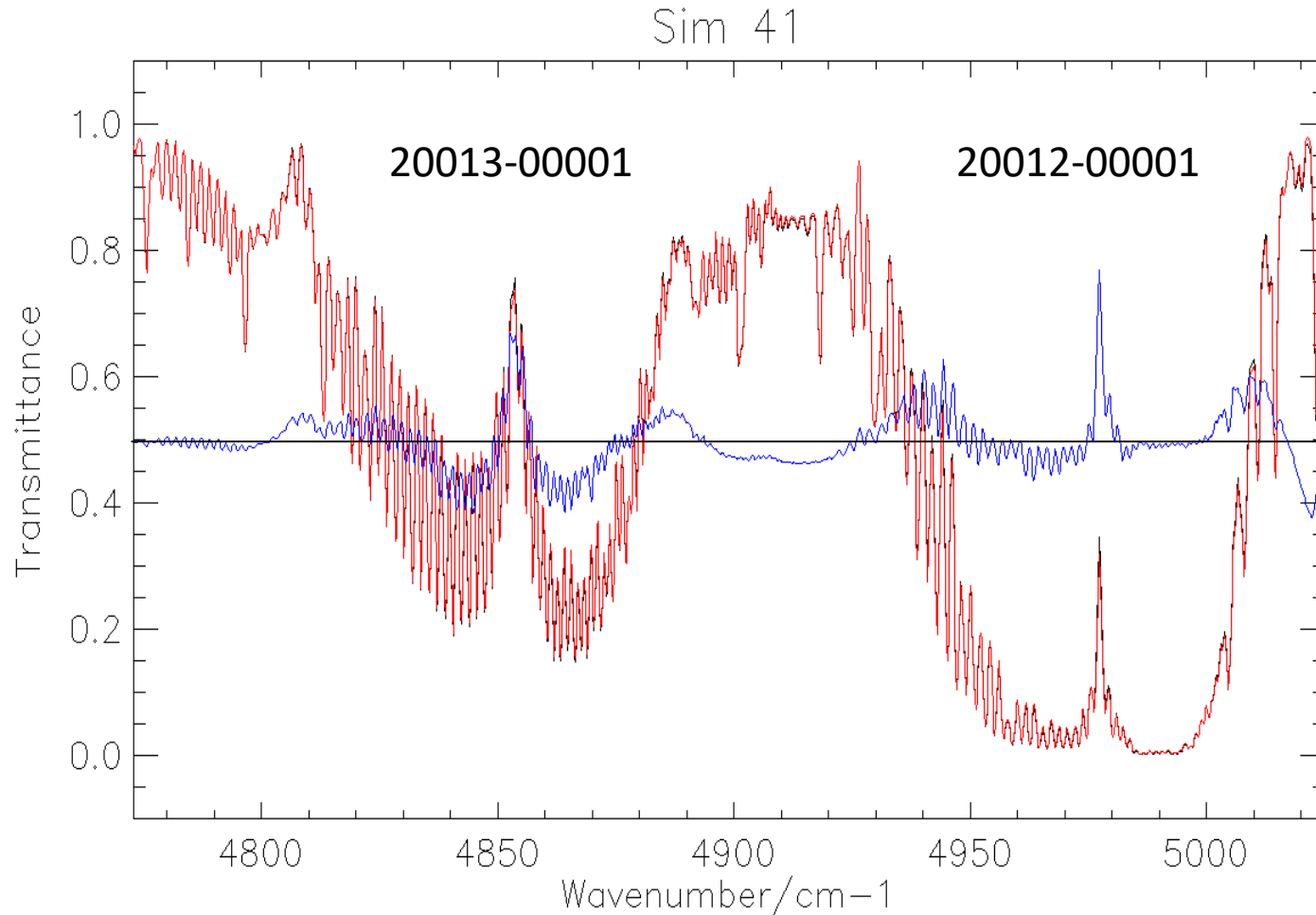

CO2M differential error on CO2 column: <0.1%

- Tropical – subarctic winter differential error
- Largest error contribution: temperature exponent of air broadening

Parameter	Feasible par. error	Feasible XCO2 error contrib./%
CO2 gamma0_air	0.002	
CO2 gamma2_air	0.1	
CO2 Y_air	0.02	-0.01391
CO2 sigma	0.0001	
CO2 delta0_air	0.0001	
CO2 gamma0_H2O	0.02	-0.03269
CO2 n_air	0.005	0.05027
CO2 Tdelta_air	2.00E-06	
CO2 T1Y_air	0.1	0.01885
CO2 Tinhom 1%	0.01	
CO2 T_error 0.1K	0.1	0.02489
CO2 Tinhom 1% NDFIT	0.01	0.01696
RSS		0.07107



Multispectrum fit of CH₄ microwindow: broadening + low temperature

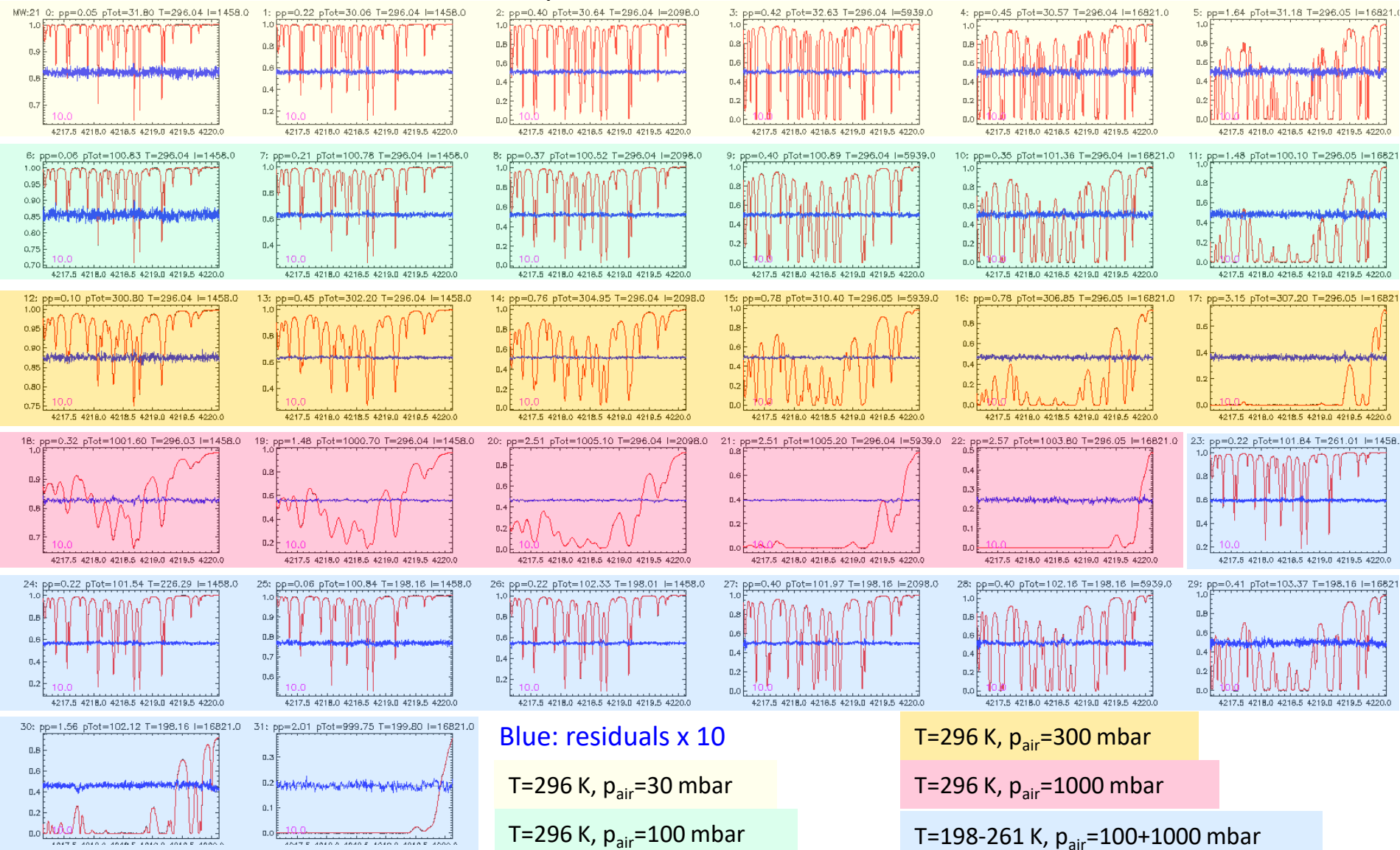

Solar occultation measurement for validation of DLR CH₄, H₂O, and CO databases for Sentinel 5P

- Solar occultation spectrum (red), Residuals green: DLR line list, black: HITRAN2012, blue: HITRAN2016, light blue: solar transmission spectrum. Courtesy Frank Hase, KIT, Karlsruhe, Germany.

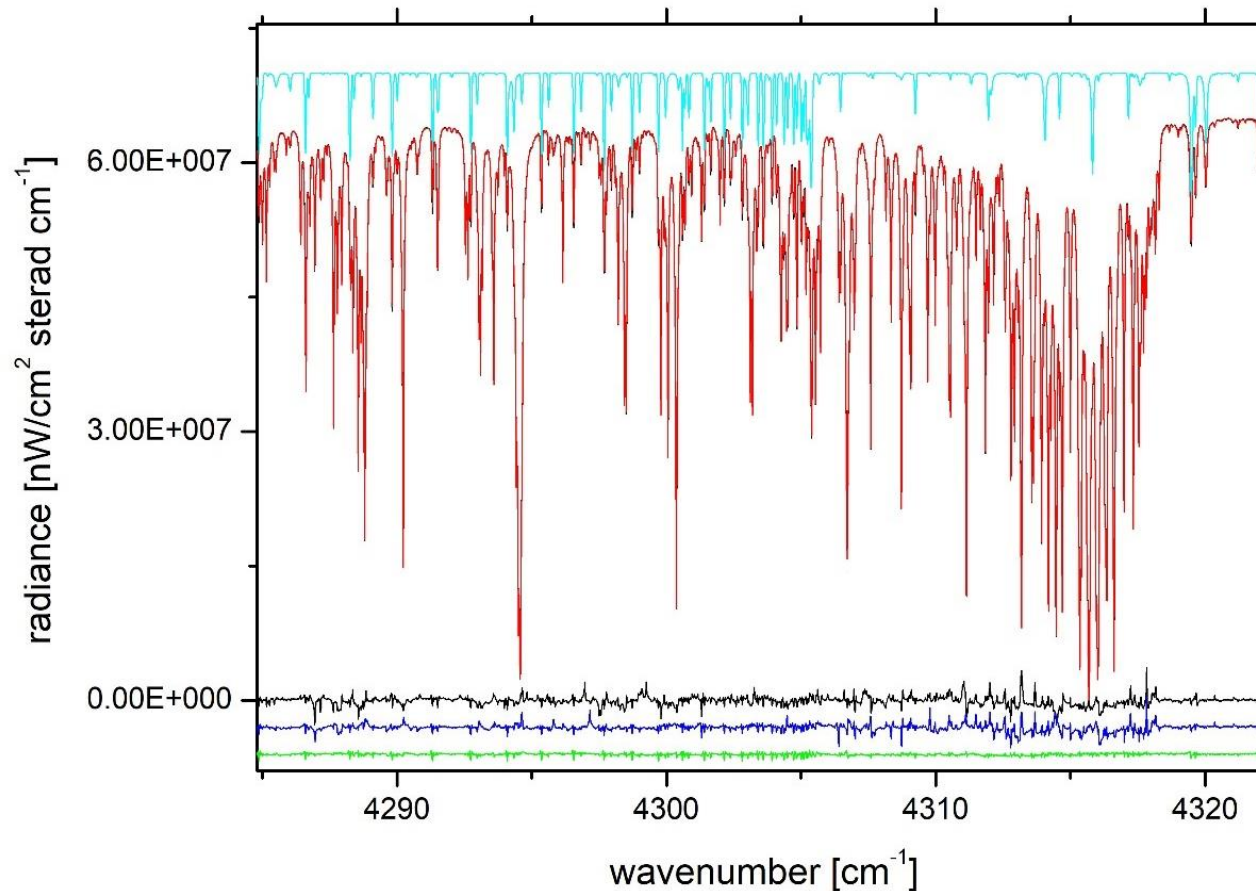

DLR CO₂ measurements in 1.6 μm region

Background: Investigate ability to measure line intensities with 0.1% accuracy
Goal to use Long et al. (NIST, GRL 2020) 1.6 μm CO₂ measurements as standard

DLR measurements

- Bruker IFS 125 HR + DLR coolable multireflection cell.
- Instrument evacuated with cryo/turbomolecular pump to 0.002 mbar.
- Detector: RT-InGaAs, cut-on 5900 cm⁻¹
- Source: Tungsten lamp
- Beamsplitter: Si on CaF₂
- MOPD: 100 cm
- Input aperture diameter: 0.8 mm



DLR CO2 measurements in 1.6 μm region

#	Pressure/mbar	Abs.path/cm
1	10.059	1456.6
2	10.304	1456.6
3	29.153	1456.6
4	30.125	1456.6
5	77.886	1456.6
6	80.098	1456.6
7	3.1362	5937.5
8	10.045	5937.5
9	30.121	5937.5
10	80.712	5937.5

CO2 from Linde, purity 99.9993%, gas was further purified by freezing out CO2 at 77 K and pumping off residual air.



Spectra #1 (red) and #10 (black) with smallest and largest column amount

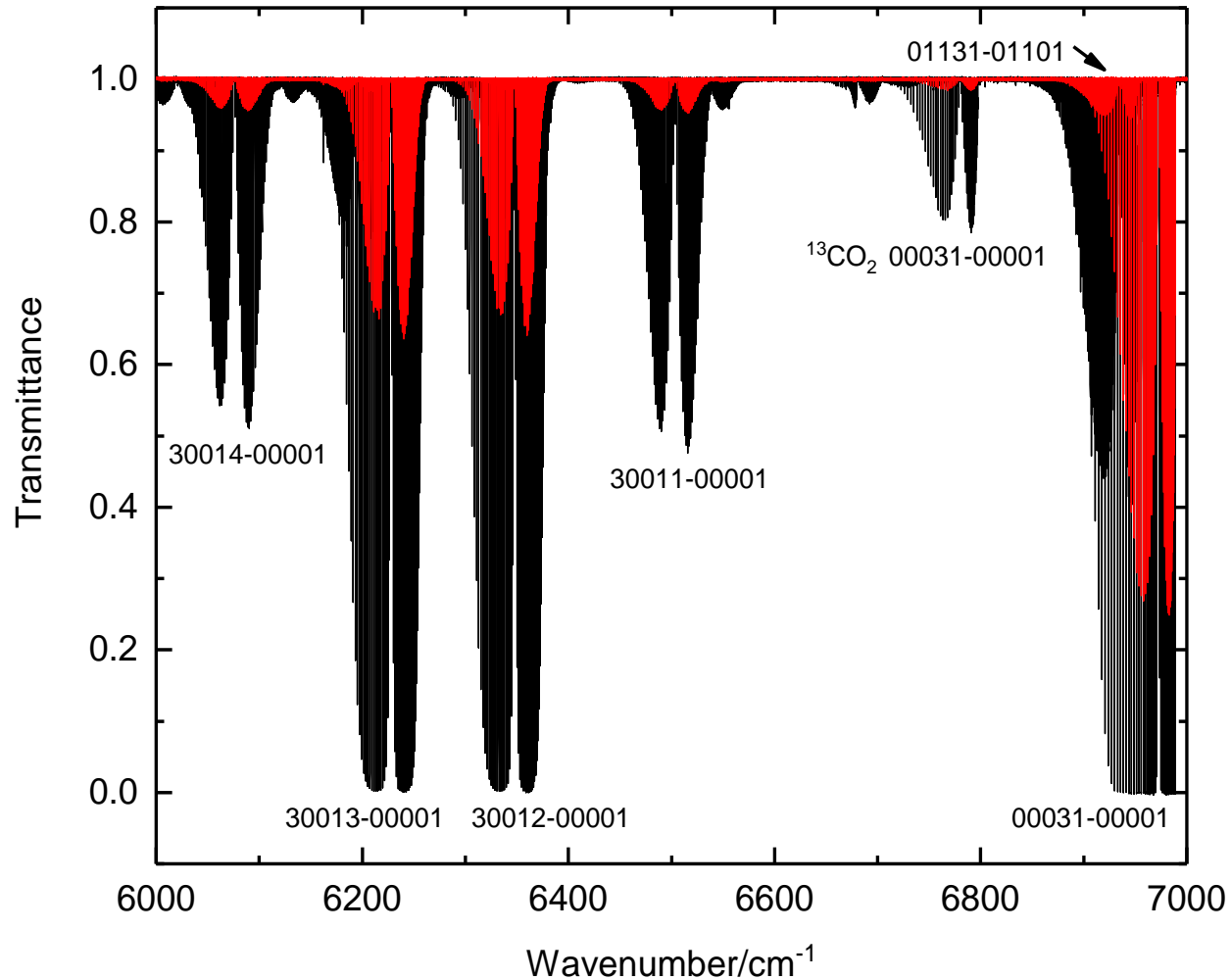

Example Multispectrum fit: Band head 00031

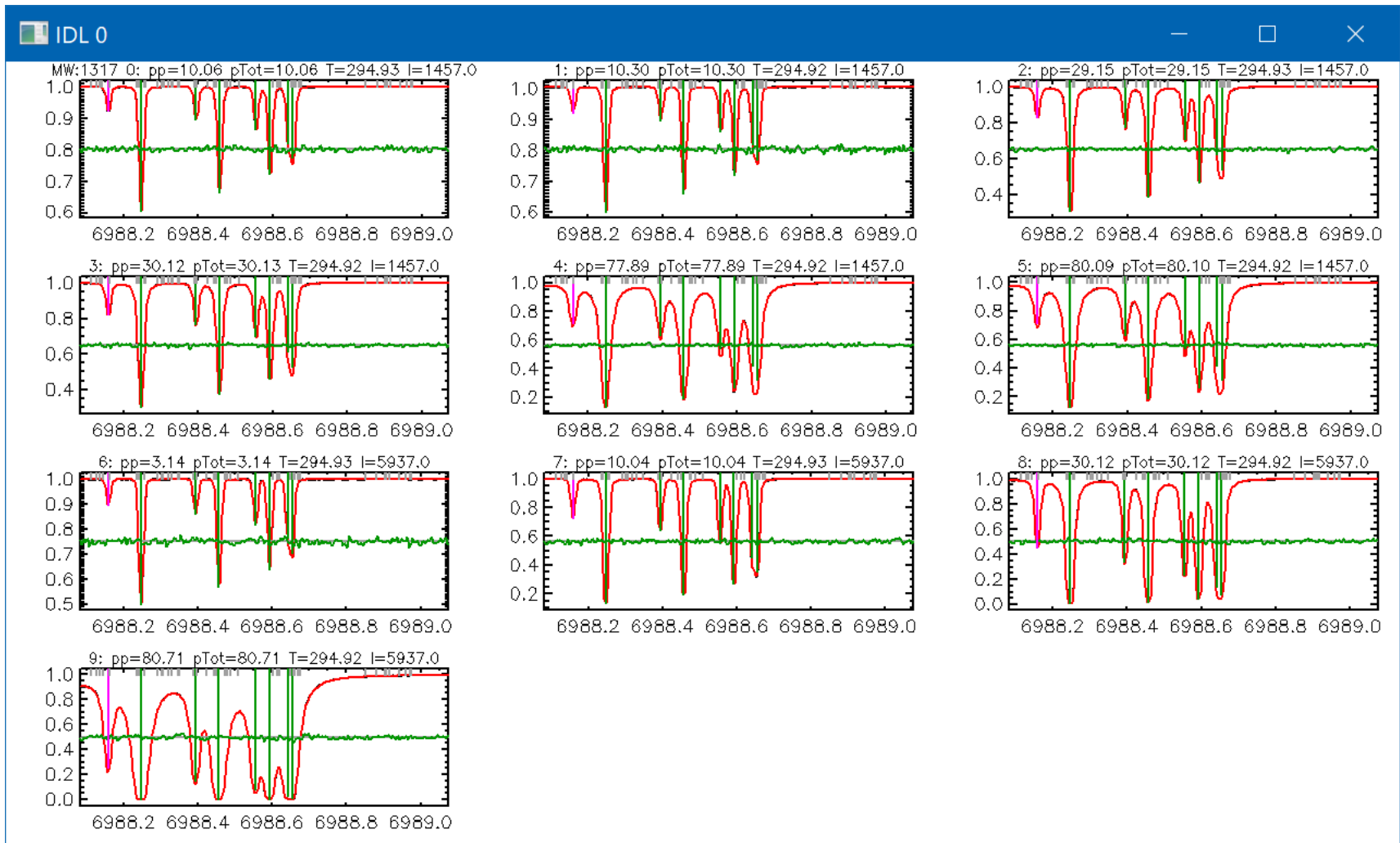

Intensity error budget

Physical Effect	Uncertainty/%	Relevant for relative band uncertainty
Systematic uncertainty in ILS	0.08	X
Pathlength	0.10	
Molecular lineshape	0.04	X
Pressure (drives density)	0.06	
Sample temperature (± 0.1 K)/300 K (drives density)	0.03	
RSS	0.15	

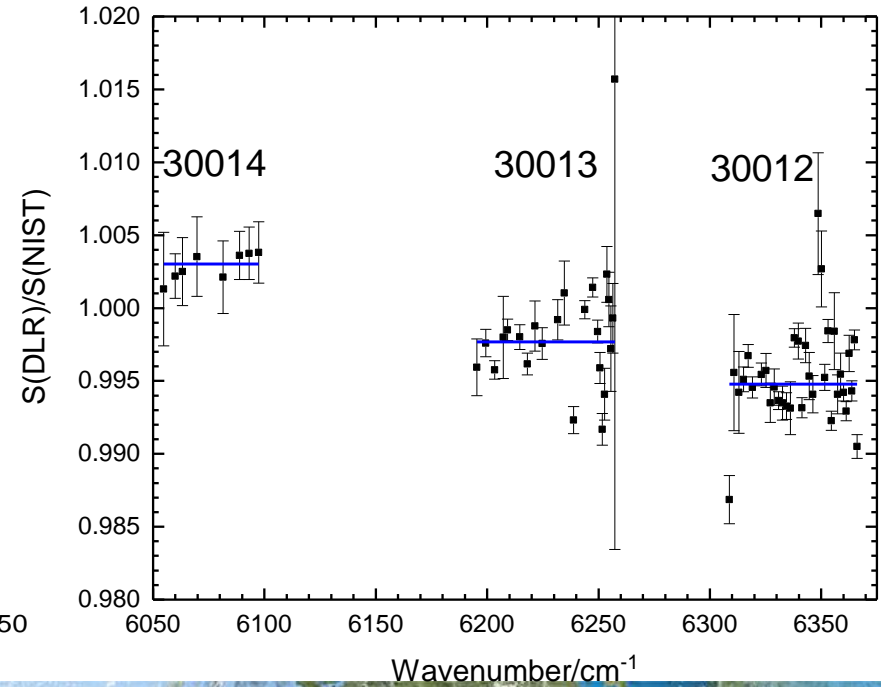
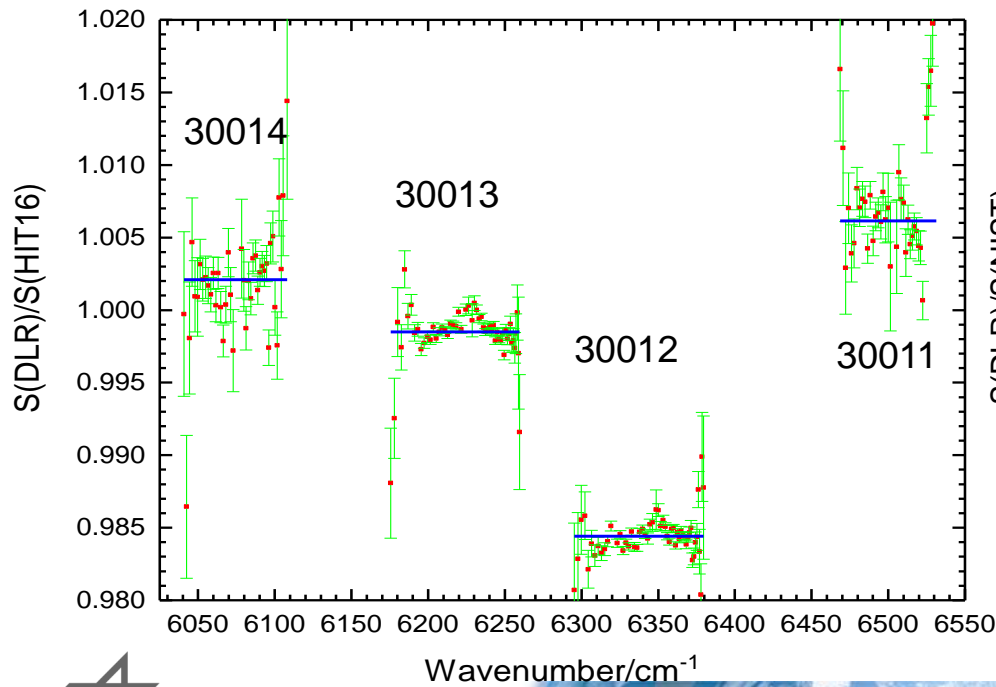

DLR vs. NIST

- Relative band intensities between NIST and DLR differ by 0.8% despite absolute intensity NIST 0.1% and DLR 0.15%
- Relative intensity error DLR <0.1%
- Consequence: Long et al. cannot be used as standard
- Further proof: Good agreement of relative and absolute intensities with Toth et al. (JQSRT 2008)
- Problem with Long et al. measurements is under investigation
- DLR results published in JQSRT 2021

Band	S_{DLR}/S_{NIST}	χ	S_{DLR}/S_{Toth}	χ	S_{NIST}/S_{HIT}	χ	S_{DLR}/S_{HIT}	χ
30011			1.00561(22)	1.5			1.00643(44)	1.3
30012	0.99479(16)	2.4	1.004105(48)	3.0	0.98960(15)	2.4	0.984417(52)	2.0
30013	0.99767(22)	2.5	1.004175(47)	3.3	1.00073(20)	3.0	0.998613(70)	2.2
30014	1.00301(73)	0.4	1.00190(23)	2.0	0.99942(57)	0.8	1.00229(43)	1.1
00031			1.002391(55)	4.7				

