



Hance, J. R., & Rarity, J. G. (2021). *Exchange-Free Ghost Imaging*. Abstract from 2021 Conference on Lasers and Electro-Optics/Europe – European Quantum Electronics Virtual Conferences (CLEO®/Europe-EQEC 2021).

Peer reviewed version

License (if available):  
CC BY

[Link to publication record in Explore Bristol Research](#)  
PDF-document

## University of Bristol - Explore Bristol Research

### General rights

This document is made available in accordance with publisher policies. Please cite only the published version using the reference above. Full terms of use are available:  
<http://www.bristol.ac.uk/red/research-policy/pure/user-guides/ebr-terms/>

# Exchange-Free Ghost Imaging

Jonte R. Hance, John Rarity

*Quantum Engineering Technology Laboratory, Department of Electrical and Electronic Engineering, University of Bristol, Woodland Road, Bristol, BS8 1UB, UK*  
*jonte.hance@bristol.ac.uk*

**Abstract:** We have developed a protocol for ghost imaging that is always exchange-free - while imaging an object, no light interacts with it. This provides both better visibility/SNR and less absorbed intensity than ghost imaging. © 2021 The Author(s)

In our recent paper [1], we introduced a new counterfactual ghost imaging scheme, where a ghost image is formed without the imaged object ever absorbing any photons. This scheme makes use of Salih et al's always-counterfactual communication protocol [2], where Alice obtains a different result depending on whether or not Bob blocks his side of a channel, without any chance of the photon having gone via Bob [3, 4] (which has even led to protocols which send quantum information counterfactually [5–9]).

Zhang et al previously combined Ghost Imaging with the Elitzur-Vaidman Bomb Detector [10] to create a form of Ghost Imaging where there is a chance that information is still received about the imaged object without any photons being absorbed by it [11]. However, the Elitzur-Vaidman Bomb Detector is at most 50% efficient, and is not always necessarily counterfactual - there is a (reasonably high) chance the photon can go via the object being investigated [12].

By replacing the Elitzur-Vaidman object-detection system in Zhang's protocol with Salih et al's method for counterfactual communication, we have created a protocol for ghost imaging that is always counterfactual - whenever information is received about the imaged object, no photons have interacted with that object. Further, even in cases when no information travels, far fewer photons go to the object than in either the standard ghost imaging or in the interaction-free ghost imaging case - reducing the energy absorbed by the object, and so potentially damage done to that object by the imaging process.

We now go over the specifics of our protocol, as shown in Fig.1. We create a pair of position-and-momentum-entangled photons, one horizontally polarised and one vertically polarised, by passing a pulsed pump laser through a spontaneous parametric downconversion (SPDC) crystal, before collimating the beam, and filtering out the pump. The photon pair is split at a polarising beamsplitter (PBS), with the  $V$ -polarised photon going through a long optical delay to an Intensified Charge-Coupled Device (ICCD) camera, and the  $H$ -polarised photon going through a run of Salih et al's protocol, adapted so the object to be investigated is put in place of Bob's blocker. The switchable mirrors allow the photon to cycle the correct number of times: the first for  $M$  outer cycles; and the second for  $N$  inner cycles per outer cycle. The polarisation separators subtly divert horizontally-polarised light, and directly transmit vertically-polarised light. The Half Wave Plates are tuned to implement a  $\hat{\mathbf{R}}_y(\theta)$  polarisation-mode rotation with  $\theta$  of  $\pi/2M$  and  $\pi/2N$  respectively. The detector  $D_L$  acts as our loss channels (which we postselect against). After  $M$  outer cycles, the switchable mirror sends the photon to the optical circulator, which sends it to the PBS. The path not being blocked by the object leads the photon to remain  $H$ -polarised, and so go to  $D_0$ , leading to a coincidence measurement between that and the ICCD camera; however, the path being blocked leads to the photon becoming  $V$ -polarised and so going to  $D_1$ , so coincidence measurement between that and the ICCD. The use of multi-mode interferometers and (position-momentum) correlations between the entangled photons enables multi-mode ghost imaging in this counterfactual set-up. Note, the polarisation separators ensure a common path length for both  $H$ - and  $V$ -polarised components, while generating beam separations of the several millimetres. A further optimisation has photons going to  $D_L$  can trigger a coincidence measurement with the ICCD, treated as if it was a detection at  $D_0$ , which does not affect the chance of photons interacting with the object (photons only go to  $D_L$  if the object doesn't block the channel), and allows us to lower the number of outer cycles to the minimum required (2) with no increase in loss.

Even for low numbers of outer and inner cycles ( $M$  and  $N$ ), our protocol gives a vast improvement over the signal-to-noise ratio of standard ghost imaging - for instance, two outer cycles of 13 inner cycles gives double the equal-photon-absorption SNR of standard ghost imaging. Note, as  $N \rightarrow \infty$ , the probability of a photon interacting with the object goes to 0, meaning  $\text{SNR}_{Int}$  becomes infinitely larger than the SNR available with standard ghost imaging (if we're willing to wait that long).

We have given a protocol for ghost imaging in a way that is always counterfactual - while imaging the object,

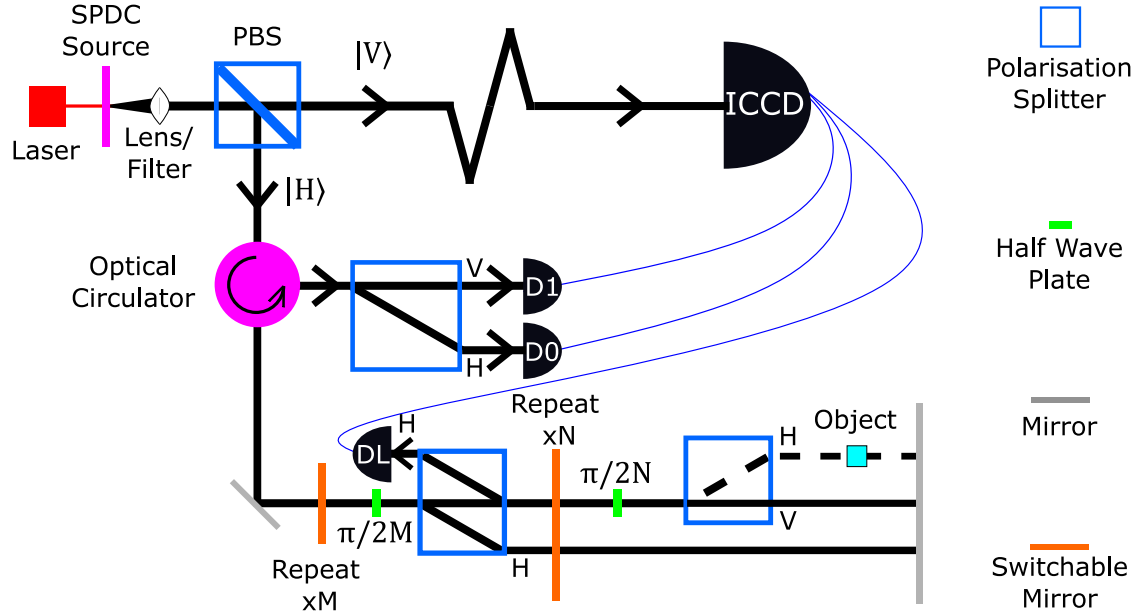

Fig. 1. Our Counterfactual Ghost Imaging Protocol, based on the combination of standard Ghost Imaging and a common-path interferometer version of Salih et al's counterfactual communication protocol [3].

no light interacts with that object. This extends the idea of counterfactuality beyond communication, showing how this interesting phenomenon can be used for metrology. Given, in the infinite limit, no photons ever go to the imaged object, it presents a method of imaging even the most light-sensitive of objects without damaging them.

*Acknowledgements-* We thank Hatim Salih, Alex McMillan and Will McCutcheon for useful discussions. This work was supported by the University of York's EPSRC DTP grant EP/R513386/1, and the Quantum Communications Hub funded by the EPSRC grant EP/M013472/1.

## References

1. J. Hance and J. Rarity, "Counterfactual ghost imaging," arXiv preprint arXiv:2010.14292 (2020).
2. H. Salih, W. McCutcheon, J. R. Hance, and J. Rarity, "Do the laws of physics prohibit counterfactual communication?" arXiv preprint arXiv:1806.01257 (2018).
3. H. Salih, Z.-H. Li, M. Al-Amri, and M. S. Zubairy, "Protocol for direct counterfactual quantum communication," Phys. Rev. Lett. **110**, 170502 (2013).
4. Y. Cao, Y.-H. Li, Z. Cao, J. Yin, Y.-A. Chen, H.-L. Yin, T.-Y. Chen, X. Ma, C.-Z. Peng, and J.-W. Pan, "Direct counterfactual communication via quantum zeno effect," Proc. Natl. Acad. Sci. (2017).
5. H. Salih, "Protocol for counterfactually transporting an unknown qubit," arXiv preprint arXiv:1404.2200v1 (2014).
6. H. Salih, "Protocol for counterfactually transporting an unknown qubit," Front. Phys. **3**, 94 (2016).
7. H. Salih, "From a quantum paradox to counterportation," arXiv preprint arXiv:1807.06586 (2018).
8. H. Salih, J. R. Hance, W. McCutcheon, T. Rudolph, and J. Rarity, "Exchange-free computation on an unknown qubit at a distance," New J. Phys. **23**, 013004 (2021).
9. H. Salih, J. R. Hance, W. McCutcheon, T. Rudolph, and J. Rarity, "Deterministic teleportation and universal computation without particle exchange," arXiv preprint arXiv:2009.05564 (2020).
10. A. C. Elitzur and L. Vaidman, "Quantum mechanical interaction-free measurements," Foundations Phys. **23**, 987–997 (1993).
11. Y. Zhang, A. Sit, F. Bouchard, H. Larocque, F. Grenapin, E. Cohen, A. C. Elitzur, J. L. Harden, R. W. Boyd, and E. Karimi, "Interaction-free ghost-imaging of structured objects," Opt. Express **27**, 2212–2224 (2019).
12. J. R. Hance, J. Ladyman, and J. Rarity, "How quantum is quantum counterfactual communication?" Foundations Phys. **51**, 12 (2021).