

©2013 International Society of Automation (ISA)

Future Energy: Opportunities and Challenges

Originally published 2013 by the International Society of Automation (ISA)

Rights for this work have been reverted to the author by the original publisher. The author has chosen to license this work as follows.

License Information:



Attribution 4.0 International (CC BY 4.0)

You are free to **share** (copy and redistribute) the material in any medium or format and **adapt** (remix, transform, and build upon the material for any purpose, even commercially) under the following terms:

	<p>Attribution. You must give appropriate credit, provide a link to the summary license (see link below), and indicate if changes were made. You may do so in any reasonable manner, but not in any way that suggests the licensor endorses you or your use. Specifically, you must state that the work was originally published in <i>Future Energy: Opportunities and Challenges</i> (2013), authored by Thomas W. Kerlin.</p>
--	---

[“Globe in hand” cover and section image](#) by Gerd Altmann made available by Pixabay License that grants an irrevocable, worldwide, non-exclusive and royalty free right to use, download, copy, modify or adapt the Content for commercial or non-commercial purposes. Attribution encouraged but not required.

For any reuse or distribution, you must make clear to others the license terms of this work as described above. Any of these conditions can be waived if you get permission from the copyright holder. Nothing in this license impairs or restricts the author’s moral rights.

The above information is only a summary of the full license, which is available at the following URL: <https://creativecommons.org/licenses/by/4.0/>

Full text of this book is made available by The University of Tennessee Libraries at the following URL: https://trace.tennessee.edu/utk_opentext/2/

This license page template was graciously provided by Virginia Tech (CC BY 4.0).

Future Energy: Opportunities and Challenges

Thomas W. Kerlin



FUTURE ENERGY: OPPORTUNITIES AND CHALLENGES

Thomas W. Kerlin

Everyone is entitled to his own opinion, but not his own facts.

*Attributed both to former Senator Patrick D. Moynihan
and to former Secretary of Defense James R. Schlesinger*

...to live on the earth's energy income rather than its energy capital.

Isaac Asimov

It is quite evident, though, that this squandering cannot go on indefinitely, for geological investigations prove our fuel stores to be limited. So great has been the drain on them of late years that the specter of exhaustion is looming up threateningly in the distance...

Nikolai Tesla (1931)

FUTURE ENERGY: OPPORTUNITIES AND CHALLENGES

Thomas W. Kerlin



Notice

The information presented in this publication is for the general education of the reader. Because neither the author nor the publisher has any control over the use of the information by the reader, both the author and the publisher disclaim any and all liability of any kind arising out of such use. The reader is expected to exercise sound professional judgment in using any of the information presented in a particular application.

Additionally, neither the author nor the publisher has investigated or considered the effect of any patents on the ability of the reader to use any of the information in a particular application. The reader is responsible for reviewing any possible patents that may affect any particular use of the information presented.

Any references to commercial products in the work are cited as examples only. Neither the author nor the publisher endorses any referenced commercial product. Any trademarks or tradenames referenced belong to the respective owner of the mark or name. Neither the author nor the publisher makes any representation regarding the availability of any referenced commercial product at any time. The manufacturer's instructions on use of any commercial product must be followed at all times, even if in conflict with the information in this publication.

Copyright © 2013 International Society of Automation (ISA)

All rights reserved.

Printed in the United States of America.

10 9 8 7 6 5 4 3 2

ISBN: 978-1-937560-28-7

No part of this work may be reproduced, stored in a retrieval system, or transmitted in any form or by any means, electronic, mechanical, photocopying, recording or otherwise, without the prior written permission of the publisher.

ISA
67 Alexander Drive
P.O. Box 12277
Research Triangle Park, NC 27709

Library of Congress Cataloging-in-Publication Data in process.

Contents

Acknowledgment xv

About the Author xvii

2021 Preface & Commentary xix

Original Preface xxiii

Part I: GETTING STARTED

Chapter 1 – Introduction to the Energy Story 3

- 1.1 The Energy Issues 5
- 1.2 Three Viewpoints 5
- 1.3 Success Stories 6
- 1.4 Getting Energy 7
- 1.5 Energy and the Environment 9
- 1.6 Making the Transformation 9
- 1.7 Preparing for the Energy Future 11
- References 11

Chapter 2 – Fundamentals 13

- The Main Points 15
- 2.1 Understanding Energy 15
- 2.2 Conservation of Energy 17
- 2.3 Energy and Power 17
- 2.4 Units of Measure 17
- 2.5 Forms of Energy 22
- 2.6 Energy Utilization 34
- 2.7 Energy Efficiency 37
- 2.8 Energy Balances 39
- 2.9 A Little Chemistry 40
- 2.10 A Little Biology 46
- 2.11 Linear vs. Exponential Growth 48
- 2.12 Energy Information on the Internet 50
- 2.13 Energy Facts vs. Energy Fiction 52
- Exercises 52

Chapter 3 – Energy Production and Consumption 55

The Main Points 57

3.1 Overview 58

3.2 World Energy Production and Consumption 59

3.3 U.S. Energy Production and Consumption 61

3.4 Oil Production and Consumption 63

3.5 Natural Gas Production and Consumption 67

3.6 Coal Production and Consumption 69

3.7 Uranium Production and Consumption 70

3.8 Electricity 71

3.9 Greenhouse Gas Release and Pollution from Energy
Production 72

3.10 Energy Recoverable from Non-Renewable Resources 73

3.11 Interpretation 75

References 76

Exercises 76

Part II: ENERGY SOURCES

Chapter 4 – Fossil Fuels 81

The Main Points 83

4.1 Introduction 84

4.2 Oil 86

4.3 Oil Sand 102

4.4 Oil Shale 105

4.5 Gaseous Hydrocarbons 107

4.6 Coal 113

4.7 Synthetic Liquid Fuels 119

4.8 Fossil Fuel Summary 124

References 125

Exercises 126

Chapter 5 – Renewables 129

The Main Points 131

5.1 Introduction 131

5.2 The Solar Resource 132

5.3 Useful Energy Derived from Sunlight 137

5.4 Useful Energy from Non-Solar Sources 138

5.5 Using Renewables 138

References 139

Exercises 139

Chapter 6 – Solar Energy 141

- The Main Points 143
- 6.1 Introduction 143
- 6.2 Solar Heating 144
- 6.3 Solar Electricity 154
- 6.4 Looking Ahead 160
- References 161
- Exercises 161

Chapter 7 – Biofuels 163

- The Main Points 165
- 7.1 Introduction 165
- 7.2 Plants and Energy 166
- 7.3 Plant Characteristics 169
- 7.4 Biochemical Processes 170
- 7.5 Thermochemical Processes 174
- 7.6 Chemical Processes and Applications 176
- 7.7 Hybrid Processes 179
- 7.8 Biofuels Requiring No Processing 181
- 7.9 Biomass-to-Biofuel Process Overview 181
- 7.10 Looking Ahead 183
- References 184
- Exercises 184

Chapter 8 – Wind Energy 187

- The Main Points 189
- 8.1 Introduction 189
- 8.2 Wind Energy Potential 190
- 8.3 Wind Energy Physics 191
- 8.4 Wind Energy Machines 192
- 8.5 Intermittency 196
- 8.6 Wind Machine Siting 197
- 8.7 Wind Energy Status and Prospects 198
- References 199
- Exercises 199

Chapter 9 – Hydroenergy 201

- The Main Points 203
- 9.1 Introduction 203
- 9.2 Physics of Falling Water Energy 204
- 9.3 Turbines and Generators 205
- 9.4 Falling Water Hydroelectric Systems 206

-
- 9.5 Pumped Storage 208
 - 9.6 River Flow, Tidal Flow, and Ocean Current Energy Converters 209
 - 9.7 Wave Energy Converters 211
 - 9.8 Tide Energy Converters 213
 - 9.9 Hydroenergy, Environmental Effects, and Public Safety Concerns 213
 - 9.10 Hydroenergy and Load-Following 214
 - 9.11 Hydroenergy Contribution to Energy Needs 214
 - References 215
 - Exercises 215

Chapter 10 – Geothermal Energy 217

- The Main Points 219
- 10.1 Introduction 219
- 10.2 Sub-Surface Conditions 220
- 10.3 The Resource 222
- 10.4 Hydrothermal Sources 223
- 10.5 Enhanced Geothermal Systems 224
- 10.6 Geothermal Energy for Heat and Electricity 227
- 10.7 Environmental Effects 230
- 10.8 Heat Pumps 231
- 10.9 Conclusions 232
- References 232
- Exercises 233

Chapter 11 – Nuclear Energy 235

- The Main Points 237
- 11.1 Introduction 238
- 11.2 Fission Reactors 238
- 11.3 Safety 243
- 11.4 Energy Costs and Environmental Impacts 250
- 11.5 Proliferation 252
- 11.6 Reactor Design Evolution 253
- 11.7 Nuclear Fuel Supply 262
- 11.8 Fusion 263
- 11.9 Nuclear Energy in the Future 265
- References 266
- Exercises 266

Chapter 12 – Hydrogen 269

- The Main Points 271
- 12.1 Introduction 271

12.2	Hydrogen Properties	273
12.3	Hydrogen Production	276
12.4	Hydrogen Storage	282
12.5	Options for Hydrogen Production Sites	283
12.6	Hydrogen Distribution	284
12.7	Use of Hydrogen as a Fuel	284
12.8	Energy Efficiency	285
12.9	Hydrogen's Future	286
	References	287

Chapter 13 – Energy Transport 289

	The Main Points	291
13.1	Introduction	292
13.2	Coal Transport	292
13.3	Liquid Fuel Transport	292
13.4	Gaseous Fuel Transport	294
13.5	Electricity Transport	297
13.6	Environmental Issues	303
13.7	Overview	304
	References	304
	Exercises	305

Part III: ENERGY DEMAND

Chapter 14 – Population and Energy Demand 309

	The Main Points	311
14.1	Introduction	311
14.2	Population History	312
14.3	Exponential Population Growth	313
14.4	The Demographic Transition and Population Stabilization	314
14.5	Total Fertility Rates	315
14.6	Future Population Estimates	316
14.7	Energy Implications	317
14.8	The Bottom Line	319
	References	319
	Exercises	319

Chapter 15 – Residential Energy Use 321

	The Main Points	323
15.1	Introduction	324
15.2	Residential Energy Consumption	325
15.3	Space Heating and Cooling Systems	330

-
- 15.4 Water Heaters 341
 - 15.5 Lighting and Appliances 343
 - 15.6 Local Electrical Energy Production 346
 - 15.7 Building Features and Lifestyles 347
 - 15.8 Possibilities 350
 - 15.9 Commentary 352
- References 352

Chapter 16 – Commercial Energy Use 355

- The Main Points 357
 - 16.1 Introduction 357
 - 16.2 Commercial Energy Use 358
 - 16.3 Capital Investment Incentives and Barriers 361
 - 16.4 Reducing Commercial Energy Consumption 363
 - 16.5 Trends 363
 - 16.6 Possibilities 364
 - 16.7 Commentary 365
- References 365
- Exercises 366

Chapter 17 – Industrial Energy Use 369

- The Main Points 371
 - 17.1 Introduction 371
 - 17.2 Consumption by Energy Type 372
 - 17.3 Consumption by Use 373
 - 17.4 Industry-Specific Consumption 375
 - 17.5 Industrial Energy Consumption and the U.S. Economy 376
 - 17.6 Supply Side Opportunities for Reducing or Modifying Energy Consumption 377
 - 17.7 Reinventing Industrial Processes 379
 - 17.8 What Can I Do? 380
- References 380
- Exercises 381

Chapter 18 – Transportation Energy Use 383

- The Main Points 385
- 18.1 Introduction 386
- 18.2 Transportation Energy Consumption 387
- 18.3 Vehicle Statistics 390
- 18.4 Vehicles with Internal Combustion Engines 393
- 18.5 Electric Vehicles 396
- 18.6 Hybrid Vehicle Status 405
- 18.7 Gas Power 405

18.8 Future Transportation Energy 405
References 406
Exercises 407

Chapter 19 – Energy and Climate Change 411

The Main Points 413
19.1 Introduction 414
19.2 Physics of the Greenhouse Effect 414
19.3 The Greenhouse Gases 416
19.4 The Greenhouse Effect 419
19.5 The Greenhouse Debate 420
19.6 Mitigation 426
19.7 Other Environmental Effects 428
19.8 Conclusions 429
References 430
Exercises 431

Chapter 20 – Energy Conservation and Efficiency 433

The Main Points 435
20.1 Introduction 435
20.2 Individual Actions 436
20.3 Business and Industry Actions 444
20.4 Government Actions 445
20.5 How Individual Citizens Use Energy 446
20.6 The Bottom Line 448
References 448
Exercises 449

Part IV: CREATING SUSTAINABLE ENERGY

Chapter 21 – Energy, Economics, and Government 453

The Main Points 455
21.1 Introduction 455
21.2 Energy Production 456
21.3 Population 456
21.4 Per Capita Consumption 456
21.5 Economics 457
21.6 Government 459
References 461

Chapter 22 – Summing Up 463

APPENDICES

Appendix A: Mass and Weight 473

Appendix B: Conversion Factors 479

Appendix C: Fuel Heating Values 485

Appendix D: Stirling Engines 487

Appendix E: Energy-related Websites 493

Appendix F: Oil Depletion Analysis: The Hubbert Solution 497

Appendix G: Solar Radiation 507

Appendix H: Orientation of Solar Collectors 519

Appendix I: Photovoltaics 527

Appendix J: Radiation Absorption Physics 531

Appendix K: Air Conditioners and Heat Pumps 537

Appendix L: Triglycerides 549

Appendix M: Bioethanol 553

Appendix N: Biobutanol 565

Appendix O: Biomethane 567

Appendix P: Physics of Falling and Moving Fluids 569

Appendix Q: Energy Use In Specific Industries 577

Glossary 591

Index 615

Acknowledgment

Thanks to Nancy for gracefully tolerating the time spent studying, learning, and writing.

Randy Gentry and David Brill of The Institute for a Secure and Sustainable Environment at The University of Tennessee provided essential encouragement and support.

Lorna Keathley prepared many of the illustrations. Her expert and professional work enhance the book.

Friends and colleagues reviewed various parts of the book. Special thanks to Gilles Zwingelstein, Ned Rosen, Tom Shannon, Lee Riedinger, Belle Upadhyaya, Larry Miller, Paul Stevens, Rafael Perez, Syd Ball, and Joe Perona.

About the Author

Tom Kerlin retired as head of the Nuclear Engineering Department at the University of Tennessee in 1998, after serving on the faculty for 33 years. His professional interests include instrumentation, nuclear reactor simulation, and dynamic testing for model validation. He has published extensively on these topics.

In addition to his university service, Dr. Kerlin founded a spin-off company, Analysis and Measurement Services Corp., to provide the nuclear industry with the testing capability that he invented for safety system sensors. Dr. Kerlin's method has been used hundreds of times in nuclear power plants in the U.S. and around the world.

Upon retiring, Dr. Kerlin studied the literature on energy production and use and concluded that there was a need for a comprehensive book on our future options that even non-specialists would understand. This book is the result.

2021 PREFACE & COMMENTARY

This is a free download of the book first published by The International Society of Automation in 2013. The content is identical to the original version except for a few corrections, mainly typographical.

Most of the book addresses the science and technology of energy production, transport and use, and that information is still as pertinent and valid as when it was written originally. It also addresses status and trends as they existed when the book was written, but the energy landscape evolves continuously.

The information presented is just a snapshot of conditions at one point in recent history. There have been some major changes in status and trends. Some examples are the increase in the size of oil and gas recoverable reserves and production rates because of hydrofracturing, the scale of renewable energy production, the growth of the electric vehicle market and the wide variations in the U.S. government policy on climate change.

The commentary on the following pages provides brief discussions of these most important changes. Those interested in obtaining more information on current status and trends can easily find it on the internet (See Section 2.12 for detailed information on useful web sites.).

The current version is still suitable for anyone interested in learning about our future energy opportunities and challenges. For use as a textbook in an energy-related course, the book can be used “as is” or can be modified by the instructor to better serve the course objectives.

COMMENTARY

This commentary provides information on some of the most significant changes since the original publication of the book. It updates to June 2021.

Oil Production. U.S. oil production increased dramatically in the second decade of the twenty-first century. The reason was the implementation of hydrofracturing. The figure below is an update of the domestic production curve in Figure 3-5. It shows production through 2021 (in thousand barrels per year). For example, the first peak is around three million barrels per year ($300,000 \times 1000 = 3,000,000$) and the second peak is around four million barrels per year.

U.S. Field Production of Crude Oil

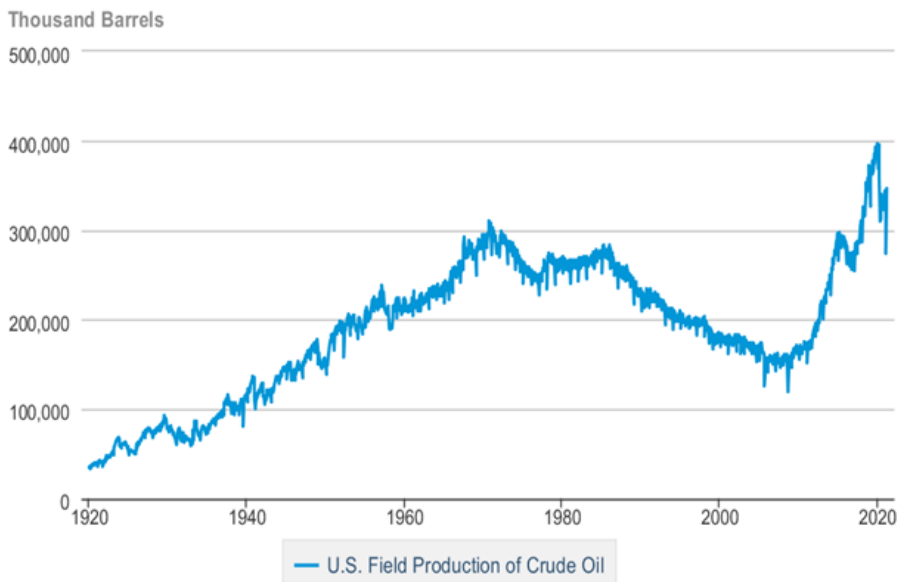

 Source: U.S. Energy Information Administration

Clearly, hydrofracturing changed the American oil enterprise tremendously, starting around 2010. But the covid-19 pandemic struck in 2020 and caused a sharp decrease in travel and the need for fuel. The trajectory after 2021 will depend on the two factors: the recovery from the pandemic and a possible major shift to electric vehicles and conservation efforts.

COMMENTARY, CONT.

Renewables. Renewable energy production increased significantly in the second decade of the twenty-first century, reaching 12 per cent of total energy consumption (surpassing coal). The contribution of each renewable energy source is shown below.

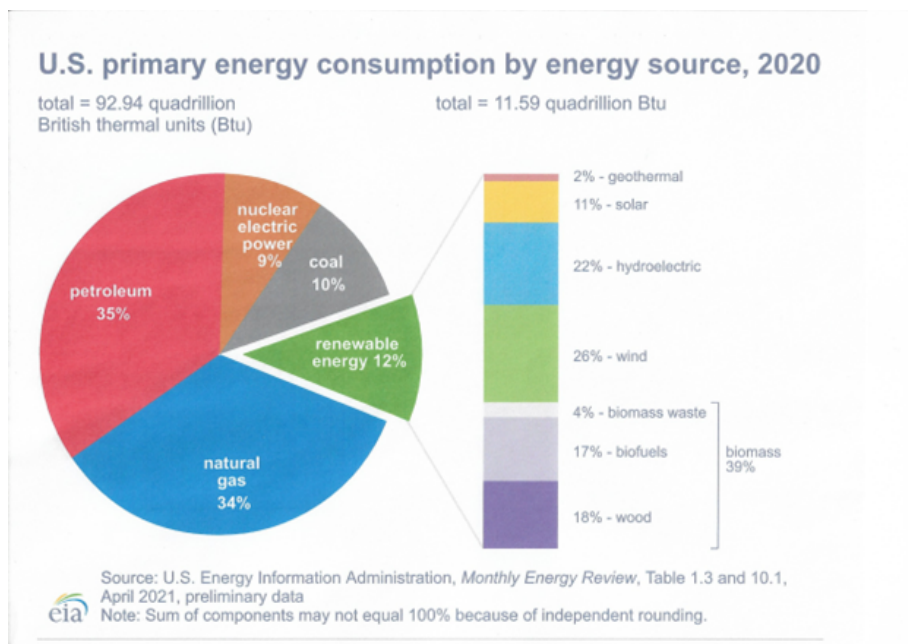

The growth of renewables, especially wind and solar, is expected to continue.

Electric Vehicles. After entering commercial markets, electric vehicle sales have soared. The global on-road number grew from 17,000 in 2010 to 7.2 million in 2019 with China having the greatest number. Many companies are producing or planning to produce electric vehicles. This includes traditional auto manufacturers (like Ford, General Motors and Chrysler) and new companies (like Tesla, the first and largest new U.S. auto company). These companies are working on improvements to increase range, reduce recharge time, reduce cost, increase battery life, reduce battery weight and improve safety. The biggest issue is range, now around 300 miles for most cars. Electric cars could be made more suitable for long trips by increasing battery energy or reducing recharge time (a recharge time of five minutes is a goal. It would make recharge time comparable to time to fuel a gasoline-powered

COMMENTARY, CONT.

vehicle).

Climate Change. The Paris Climate Accord was formulated in 2015 by countries (including the U.S.) to limit greenhouse gas emissions in order to limit warming. President Trump (2016-2020) withdrew the U.S. in 2017, citing cost and job losses. President Biden rejoined shortly after his inauguration in 2021. The Biden administration strongly commits to reducing greenhouse emissions.

Reducing emissions costs money and different countries have different abilities to absorb the cost without facing major impacts on their economy. Generally, developed countries are better able to absorb these costs than developing countries. Paris Accord countries negotiate to strive for fair treatment of countries in their efforts to curb greenhouse gas emissions. This involves setting affordable goals and subsidizing poorer counties. Each country must weigh its own immediate priorities versus long-term global priorities. Consequently, negotiations are complex and difficult.

ORIGINAL PREFACE

A revolution in energy production and use is upon us. Huge changes are starting to rumble through our lives. We cannot avoid these changes, but we can manage them if we approach them in an informed way.

Our current dependence on fossil fuels for most of our energy must be reduced or eliminated because of resource depletion and the environmental effects of fossil fuel combustion.

This book offers no prescriptions for achieving a desirable energy future. Instead, it presents the scientific and technical information needed to evaluate our options for intelligent energy production and use.

Everyone uses energy, and many are appropriately concerned about future energy cost, availability, and environmental impact. Some are content to rely on what the “experts” tell them. Others want to know enough about how energy systems work to be able to make their own assessments. Serving this group is the focus of this book.

In order to understand energy production and use, it is necessary to build on a foundation of indisputable facts. This requires some consideration of basic science, but nothing beyond that science which is taught in high schools. Science tells us what is possible and, probably more importantly, what is impossible. Science also provides the framework for obtaining quantitative evaluations of possibilities in energy production and use. Without a basis in science, and without the use of scientific principles to generate numerical assessments, statements about energy production and use must be viewed as uninformed opinion rather than established fact.

It is expected that this book will be used in survey courses about energy in universities and colleges. The book also should serve interested citizens who want to learn about energy and energy professionals who want to learn about energy options outside their specialty. An effort was made to present the science and technology in a simple and intuitive way. When detailed

information was considered necessary for readers who wish to see the basis for assertions in the main text, more detailed discussions appear in appendices.

Exercises are provided for most of the chapters. These are intended primarily for use in college and university courses. Each exercise has one of three purposes: to provide experience in using some of the quantitative assessment methods, to send the reader to current literature to learn about the status of the rapidly changing energy enterprise, and to stimulate the reader to formulate opinions and provide the rationale for those opinions.

Part I: GETTING STARTED



1

Introduction to the Energy Story

1.1 The Energy Issues

Harnessing nature's bounty of energy has enabled humanity to exist in great numbers and to prosper. Throughout history, changes in energy production and use have occurred as technological innovations created new opportunities. However, it is now clear that continuing current practices and trends in energy production and use cannot continue unchanged.

The energy question revolves around two goals: providing enough sustainable energy to satisfy human requirements, and ensuring that supplying this energy does not result in unacceptable environmental consequences. Accomplishing these goals will require informed decisions about what to do and how to do it. Currently, opinions vary on the best path to follow.

1.2 Three Viewpoints

At one extreme of the energy debate are those who say that concerns about energy resource depletion and environmental effects are unfounded. They feel that energy will be available as needed and that environmental effects associated with using it are acceptable. They see no need to embark immediately on radical changes in energy production and use. Following the example of Deffeyes¹, I will call them cornucopians.

There are also those who say we must quickly and radically change our energy habits and policies because of fossil fuel depletion, environmental effects, cost, and achieving or maintaining world peace. They believe energy habits and policies from the twentieth century are unwise, unsustainable, and unnecessary. They are generally in favor of transforming to greater reliance on conservation and renewable energy to create a sustainable condition. I will call this group the transformarians.

A third, smaller group believes there will be a world-wide crisis caused by the unavailability of energy and by environmental degradation regardless of what we do². This is the dystopian view of the future. I will call this group the futilitarians.

Proponents of each of these positions make detailed arguments for their stance. Basically they look at the same data and draw different conclusions. It may be argued that the proponents of each position are influenced by their political and philosophical persuasions as well as by their assessment of technical issues.

Many proponents of all three viewpoints remain convinced of the validity of their position. It is now clear that the cornucopian viewpoint is inconsistent with finiteness of resources, environmental effects, and the unlikely prospect of developing totally new energy technologies. The futilitarian approach is unacceptably defeatist. Transforming to a new era of energy supply and use is essential for America and the world.

In following the transformarian approach, it is important to make the correct transformations. To do so requires some familiarity with technical issues. Discussions about technology with individuals who are not familiar with the underlying science are difficult. Such is the case in discussions about energy. Non-specialists may even question whether they need to make an effort. If the lights come on, why ask about how electricity works? In the case of energy, there are very good reasons for the non-specialist to want to understand the science and technology. Technical and political decisions made by governments, businesses, and individuals will certainly influence our economy, our health, our comfort and convenience, and whether we suffer war or enjoy peace. Everyone has a stake in the energy game.

Every energy production means has undesirable side effects. Decisions about future implementations must consider the trade-offs between benefits and side effects.

1.3 Success Stories

In assessing what is possible in transforming energy use, it is helpful to examine serious efforts that have already taken place. Four countries are especially noteworthy for their efforts to reduce reliance on fossil fuels.

Brazil has eliminated the need for fuel imports by transforming from oil-based fuels to ethanol for transportation fuel. Brazil took advantage of its huge capability to grow sugar cane and built the infrastructure to manufacture ethanol and use it for transportation needs.

Iceland is another interesting case. Iceland has a small population, whose electrical and heating needs are largely supplied by ample hydroelectric and geothermal resources. Iceland is now converting from oil-based transportation fuel to hydrogen produced by the electrolysis of water using its cheap electric power.

France, with negligible domestic fossil fuel resources, has moved aggressively to nuclear power, which now satisfies over 80 percent of its electrical energy needs.

Portugal has no fossil fuels, but has ample hydroelectric, wind, and solar energy production capabilities. Through strong government action, Portugal increased its renewable electricity production from 17 percent in 2005 to 45 percent in 2010.

All four countries have successfully transformed their energy systems to reduce the use of fossil fuels. Each case is very different and extrapolation to applications in other countries where resources, requirements, and attitudes are different is inappropriate. Nevertheless, these cases show that huge transformations are possible where the will to act exists.

1.4 Getting Energy

The energy available in the thin husk of the earth where humanity lives and captures energy is almost all nuclear in origin. Nuclear fusion-generated energy from the sun heats the earth directly and can also be used to produce electricity with solar cells or solar thermal systems. Solar energy enables plants to grow and causes wind and precipitation. Radioactive decay of elements in the earth causes heating in the depths.

Modern society currently relies on fossil fuels for most of its energy. The energy in fossil fuels is the result of the capture of solar energy by plants that lived long ago. The remains of plants and animals (which were directly or indirectly dependent on plants for food) were buried under sediment. These materials underwent chemical changes when subjected to high pressures and temperatures that occurred when they were buried deep in the earth for millions of years. The result is fossil fuels: natural gas, coal, and oil. The use of fossil fuels releases solar energy that was stored in biomass long ago and also releases chemicals into the atmosphere that were previously trapped in the earth. The main concern is the conversion of trapped carbon into atmospheric carbon dioxide, which is thought to contribute to global warming.

We have come to depend heavily on fossil fuels because of their convenience of use in applications related to modern living. But the energy stored in biomass long ago and now contained in fossil fuels is a finite resource that is being depleted steadily. Of course, we use the cheapest, easiest-to-obtain materials first. As a resource becomes scarce, we accept the higher and higher costs associated with more difficult acquisition, but eventually these increased costs force us to consider other energy sources that were previously uneconomical, unknown, or inadequately developed.

The most recent major addition to our energy resources menu is nuclear fission in rare, heavy elements, such as uranium (naturally occurring) and plutonium (produced in nuclear reactors). Another potential nuclear energy source, nuclear fusion, produces energy by combining light elements at very high temperatures, but this source is not yet practical because of technical difficulties.

The next chapter in the energy story will involve a different mix of energy sources than we now use. Fossil fuels will see continued use, but will represent a decreasing fraction of total energy production. Nuclear systems are capable of contributing significantly, but their future is uncertain because of the impossibility of predicting the outcome of the controversy about nuclear safety vs. benefits of clean nuclear power from domestic resources. Candidates for increased implementation are biofuels, solar energy systems,

wind turbines, hydroenergy systems, and geothermal energy systems. Most of the science underlying these energy sources is old and well-established. But knowing the science does not ensure that large-scale implementations are feasible, practical, or sustainable. Much remains to be done before new energy sources can make a major contribution to our energy supply.

Creating a sustainable energy future requires that we consider all available sources and implement use patterns that are sustainable in terms of continued energy availability and protection of the environment.

1.5 Energy and the Environment

The current use of energy technologies impacts our environment through the release of gases (most notably, carbon dioxide) and pollutants. Scientific evidence indicates that atmospheric carbon dioxide contributes significantly to global warming. Some contend that the manmade contribution to climate change is insignificant compared to naturally-occurring effects. As we shall see in Chapter 19, the informed consensus is that manmade emissions are a real problem and must be minimized.

1.6 Making the Transformation

Transforming to a sustainable energy future will require a move away from fossil fuel use and towards reliance on biofuels and on electricity from solar, wind, hydroenergy, geothermal, and nuclear sources. Transportation must increase its reliance on energy from electricity and biofuels. Heating applications must switch to greater use of electricity, direct solar heating, geothermal sources, and biofuels.

Bioenergy production is limited by the large requirement for land to grow dedicated energy crops or to provide agricultural scrap material for collection. Wind and solar systems can produce great quantities of electricity, but both will require massive construction projects. They will also require the commitment of large land areas, but the land requirements could be met

with areas unsuitable for agriculture and in locations where coexistence with current use is possible.

Most suitable sites for large hydroelectric dams have already been used. Smaller dams and river diversions, river and ocean currents, waves, and tides are potential suppliers of significant future energy, but exploiting these sources depends on overcoming major technical and/or financing obstacles.

Geothermal resources, defined by hot rocks within about six miles of the earth's surface, are huge, but accessing the energy will require successful major implementation of new drilling and rock modification technology.

Nuclear power from fission reactors can provide electrical energy for many years, especially if breeder reactors are employed. The reserve of uranium needed for fission reactors is large, but this too is a finite resource. Fusion reactors are theoretically capable of supplying huge quantities of energy, but development of practical designs remains a challenge. The nuclear safety issue (including reactor safety and nuclear waste handling) will be a factor in determining the extent of nuclear energy use in the future.

Overall, it is certain that providing adequate energy in the future will be difficult, in the near term (decades) and the long term (centuries), and that no single technology will be sufficient.

Now consider energy consumption. Highly developed societies currently have huge energy appetites. For example, the U.S., with less than 5 percent of the world's population, consumes about 20 percent of the world's energy. Increasing world population and increasing demands from countries that move from underdeveloped conditions to fully developed conditions will increase world energy demand and competition for resources. Reducing per capita consumption by improving the efficiency of energy use can ease the strain on resources somewhat but cannot eliminate the inevitable need for more energy.

1.7 Preparing for the Energy Future

Energy is the key to achieving and maintaining modern societies. At one extreme, sufficient energy enables comfort and prosperity for large populations. At the other extreme, insufficient energy limits the possibilities for peace and survival. Failure to prepare for tomorrow's energy needs is hugely irresponsible. Subsequent chapters will provide the essential information needed to make informed decisions about our energy future.

In these chapters, data are presented for energy production and consumption. The purpose of presenting these data is to provide a snapshot of how we now produce energy and how we use it. The data should be viewed as representative rather than absolute. Data often are not available for every year, and different sources often report slightly different values for the same quantities. Furthermore, production and consumption change as economic conditions change, as resource availability and cost change, and as new technology is implemented. Nevertheless, one must understand current conditions before addressing the future.

References

1. Deffeyes, K. S. *Beyond Oil* New York: Hill and Wang, 2005.
2. <http://dieoff.org>

2

Fundamentals

The Main Points

- An understanding of basic physics, chemistry, and biology permits the quantitative assessment of energy options.
- There are different forms of energy, but mechanical energy, thermal energy, and electrical energy are the energy forms usually desired for practical applications.
- Transformations from one form of energy to another are possible and are routinely performed.
- Energy is always conserved in transformation processes.
- Heat production accompanies all transformation processes, and this heat is usually viewed as waste.
- Plants use energy from the sun to produce biomass by photosynthesis. The captured energy is the maximum energy that can subsequently be obtained from the biomass or from biofuels produced from the biomass.
- Electricity and hydrogen must be manufactured. They are energy carriers rather than energy resources.

2.1 Understanding Energy

Producing energy and transforming energy from one form to another are the stuff of physics, chemistry, and, increasingly as we develop renewable energy sources, biology. Fortunately, it is NOT necessary to be a physicist, a chemist, or a biologist to understand the important concepts. But the concepts are crucial to understanding the energy issue. If they are new to you, please pay close attention to the material in the rest of this chapter. The concepts presented below provide a brief look at the science needed for

quantitative understanding of the energy story. How they relate to energy production and use appears in future chapters.

We begin with definitions of some key terms that appear in discussions of energy.

Force is that which causes a body to accelerate. The quantitative relationship, called Newton's Second Law, is

$$F = ma \qquad (2-1)$$

where

F = force
m = mass
a = acceleration

Mechanical work is the product of a force operating on an object in some direction and the displacement of that object caused by the force. It should be noted that the word "work" has many meanings in the English language. "Work" may be a noun or a verb. One might say that solving algebra problems or holding a heavy bag of groceries is work, but these activities do not satisfy our definition of mechanical work.

Energy is the capacity to do work. If an object transfers energy to another object, it transfers the capacity to do work. For example, a stream of flowing water possesses energy. If the water stream is used to turn a paddle wheel, part of the energy in the water stream is transferred to the paddle wheel, and the rotation of the paddle wheel can be used to do work.

A study or understanding of energy involves five components: energy production, energy storage, energy transport, energy use, and energy waste. We will address all of these in later chapters.

2.2 Conservation of Energy

A simple, but very important, law of physics is called the law of conservation of energy. It states: Energy cannot be created nor destroyed. It can only change form.

You can change forms of energy, but you can't get more energy out of a system than was put in.

The law of conservation of energy is also called the first law of thermodynamics.

For example, when wind turns a windmill, the windmill gains energy at the expense of the wind, so the wind must lose energy (slow down). A hybrid car may recover energy during braking, but that energy must have been produced previously by the car's engine. To use the classic expression, there is no free lunch.

2.3 Energy and Power

In evaluating the performance of energy systems, we are interested in how fast energy is flowing as well as the total amount of energy involved in some process. For this, we use the concept of power. Power is just the rate of energy flow. A low power device can deliver (or use) just as much energy as a high power device, but it will take longer.

2.4 Units of Measure

In order to be really useful, a technical concept must somehow be related to numerical values. Dollars and euros and yen were invented by man to make the concept of money meaningful and quantifiable. Similarly, it must be possible to assign numerical values to measures such as temperature, mass, length, speed, force, energy, and power. It would be nice if there were only one set of units. But just like there are different currencies with different rates of exchange with other currencies, there are different measures for

physical quantities. Each of these measures can be converted into an equivalent alternate measure, just like currency. There are two different fundamental systems in use today, the SI (for Systeme International d'Unites) system and the U.S. Customary system.

2.4.1 Mass and Weight

The SI system is often called the MKS system because it is based on meters for length, kilograms for mass, and seconds for time. Similarly, the U.S. Customary system is often called the FPS system because it is based on feet for length, pounds for weight, and seconds for time. Therein lies a huge seed for confusion. One system uses kilograms for MASS, and the other uses pounds for WEIGHT. But a bunch of bananas that registers 1 kilogram on a scale in France would register 2.2 pounds on a scale in America. One might conclude that mass and weight are simply proportional measures of the same thing, but that is not true. The correct definitions are:

Mass = a measure of an object's tendency to maintain its state of motion (inertia)

Weight = the force on a body due to gravity.

One might correctly say that a mass of 1 kilogram is the same as a mass that weighs 2.2 pounds.

Appendix A addresses the mass vs. weight issue. Here it suffices to note that:

$$W = mg \tag{2-2}$$

where

W = weight
m = mass
g = acceleration due to gravity.

On the surface of the earth, g has a value of 9.81 meters per second per second in SI units and 32.17 feet per second per second in U.S. Customary units. Therefore, in SI units, the unit of weight is $9.81 \times \text{mass}$ (in kilograms) and is called the Newton. In U.S. Customary units, the unit of mass is weight (in pounds)/32.17 and is called the slug.

If one is working with a formula containing mass as a variable, the kilogram is the appropriate measure in the SI system, and the slug is the appropriate measure in the U.S. Customary system.

2.4.2 Energy and Power Measures

A convenient process to use in considering energy and power units is the heating of water. The calorie (an SI unit) is defined this way:

1 calorie = the amount of heat energy required to raise the temperature of one gram of water by one degree Celsius.

For example, if a heater raises 100 grams of water by 2 degrees Celsius, we know that 200 calories of heat energy were added to the water.

In the U.S. Customary system, the British thermal unit (BTU) is defined as follows:

1 BTU = the amount of heat required to raise the temperature of one pound of water by one degree Fahrenheit.

The units of energy apply equally for all forms of energy. For example, we may speak of a BTU of thermal energy or a BTU of mechanical energy or a BTU of electromagnetic energy.

The Joule, defined in mechanical terms as the energy exerted by a force of one Newton acting to move an object through a distance of one meter, is a common energy measure in the SI system. One Joule is equal to 0.239 calories or 9.4762×10^{-4} BTU. The watt is a unit of power and is equal to one Joule per second.

Prefixes are used, especially in the SI System, to indicate multiples of basic units. For example, kilo is the prefix meaning 1,000. Therefore, a kilojoule is 1,000 Joules and is abbreviated as kjoule. The prefixes for multiples of basic units are defined as follows:

Multiplier Prefix Symbol

- 10^3 kilo k
- 10^6 mega M
- 10^9 giga G
- 10^{12} tera T
- 10^{15} peta P
- 10^{18} exa E
- 10^{21} zeta Z

Relationships between some of the most common energy and power measures are shown in Table 2-1.

Example 2.1

To illustrate the use of the energy conversion factors, consider a process involving 15,000 BTU. The corresponding number of calories is $15,000 \times 252 = 3,780,000$.

As will be shown in later chapters, annual U.S. and world energy production and consumption are measured in quadrillions of BTUs (Quads) primarily in U.S. publications and in Exajoules or MTOE in some other countries. It is noteworthy that energy measures in Quads or Exajoules are about equal. It should also be noted that a quadrillion is defined differently in the U.S. and many other countries. In the U.S., a quadrillion is 10^{15} , and in most of the rest of the world, a quadrillion is 10^{24} . In subsequent sections of this book, the U.S. convention is used. A more complete list of useful conversion factors is given in Appendix B.

Table 2-1. Some Conversion Factors

To	Joule	Exajoule	Calorie	BTU	Quad	Kwhr	MTOE
From							
Joule	1	10^{-18}	0.239	9.48×10^4	9.48×10^{-19}	2.78×10^{-7}	2.35×10^{-17}
Exajoule	10^{18}	1	2.39×10^{17}	9.48×10^{14}	0.948	2.78×10^{11}	23.5
Calorie	4.184	4.184×10^{-18}	1	3.97×10^{-3}	3.97×10^{-18}	1.16×10^{-6}	9.82×10^{-17}
BTU	1054	1.06×10^{-15}	252	1	10^{-15}	2.93×10^{-4}	2.48×10^{-14}
Quad	1.054×10^{18}	1.055	2.52×10^{17}	10^{15}	1	2.93×10^{11}	24.8
Kwhr	3.6×10^6	3.6×10^{-12}	8.6×10^5	3412	3.412×10^{-12}	1	8.45×10^{-11}
MTOE	4.25×10^{16}	0.0425	1.02×10^{16}	4.0×10^{13}	0.040	1.18×10^{10}	1

where MTOE = million tonnes of oil equivalent

2.5 Forms of Energy

It is useful to categorize the different forms of energy. We will be concerned with six forms of energy: mechanical, thermal, chemical, electrical, electromagnetic, and nuclear.

2.5.1 Mechanical Energy

The forms of mechanical energy are either kinetic energy or potential energy.

Kinetic energy is energy possessed by an object because of motion. A traveling bullet, a moving bus, and a wisp of breeze all possess kinetic energy. If an object moves faster, it possesses more kinetic energy. A bus traveling at 100 miles per hour possesses more kinetic energy than a bus traveling at 10 miles per hour. A heavier object has more kinetic energy than a lighter object traveling at the same speed. A baseball traveling at 100 miles per hour possesses less kinetic energy than a bus traveling at 100 miles per hour.

In order to permit assessments of kinetic energy, it is essential to quantify the relation between kinetic energy and the mass and speed of a moving object. The formula is as follows:

$$KE = 1/2mv^2 \quad (2-3)$$

where

- KE = kinetic energy
- m = mass of the moving object
- v = speed of the moving object

In the SI system, it is common to express mass in kilograms and speed in meters per second. If this is done, then the corresponding energy is expressed in Joules.

Example 2.2

Consider a 10-kilogram mass moving at 100 meters/second. The kinetic energy possessed by the mass is given by:

$$\begin{aligned} KE &= 1/2 \times 10 \times 100^2 \\ &= 500,000 \text{ Joules.} \end{aligned}$$

The result for this example can be converted to BTUs using the conversion factor of 0.948×10^{-3} BTU per Joule to obtain 474 BTU.

Potential energy is stored energy. Gravitational potential energy is stored energy of position. As we shall see, there are various ways to store energy, and, strictly speaking, there are various forms of potential energy. However, it is common usage to refer to gravitational potential energy simply as “potential energy.” Other forms of potential energy, such as chemical energy, generally omit specification of the term “potential.” We will follow convention and use the term “potential energy” as uniquely equivalent to gravitational potential energy.

A stone suspended above the ground possesses potential energy. If the stone is released, its potential energy is transformed into kinetic energy as it falls. Potential energy increases as the distance through which it responds to a force (gravity in this case) increases. A stone suspended 100 feet above the ground possesses more potential energy than the same stone suspended 10 feet above the ground. Heavier objects possess more potential energy than lighter objects held at the same elevation. A one-ton stone possesses 2,000 times as much potential energy as a one-pound stone located at the same height.

The formula for potential energy is as follows:

$$PE = mgh \tag{2-4}$$

or equivalently:

$$PE = Wh \quad (2-5)$$

where

- PE = potential energy
- h = height above a selected reference point (such as the surface of the earth)
- W = weight of the object

If mass is expressed in kilograms, and height is expressed in meters, the corresponding energy unit is the Joule. If weight is expressed in pounds, and height is expressed in feet, the corresponding energy unit is the foot pound. As shown in Appendix B, the conversion between Joules and foot pounds is 1.356 Joules per foot pound.

Example 2.3

A 10-kilogram object suspended 10 meters above the earth has a potential energy of 980 Joules.

Now repeat the calculation in U.S. Customary units. A mass of 10 kilograms has a weight of 22.05 pounds. A height of 10 meters is equivalent to 32.81 feet. Therefore the potential energy is $22.05 \times 32.81 = 723$ foot pounds.

Using the conversion from foot pounds to Joules gives $721 \times 1.356 = 980$ Joules, thereby demonstrating the consistency between the different units of measure.

2.5.2 Thermal Energy

Hotter objects possess more thermal energy than cold objects of the same mass. Energy production and consumption processes often involve adding thermal energy to or removing thermal energy from a system so as to raise or lower its temperature or to induce vaporization or condensation.

A crucial question is, “How much energy must be added or removed in order to achieve a desired temperature change?” The relation between energy supplied or removed and the corresponding temperature change for a material is quantified by a property of matter called the specific heat capacity, abbreviated as C . It is defined in SI units as:

C = heat (calories) required to change the temperature of one gram of material by one degree Celsius

or in U.S. Customary units:

C = heat (BTU) required to change the temperature of one pound of a material by one degree Fahrenheit

For liquid water, the specific heat capacity conveniently has a value of 1.0 in both measurement systems.

The specific heat capacity of compressible fluids (gases and, to a slight extent, liquids) depends on whether the temperature change occurs at constant pressure or constant volume. If the process occurs at constant pressure, the fluid volume must increase when the temperature increases, and this increases the energy needed because of work performed on the surroundings. Specification of the specific heat capacity for compressible fluids requires two quantities: C_p , the specific heat capacity at constant pressure, and C_v , the specific heat capacity at constant volume. C_p is always larger than C_v .

Energy processes often involve vaporization or condensation. Vaporization requires an input of energy, and condensation results in a release of energy. Condensation of a given mass of vapor releases exactly the same amount of energy as that required to vaporize that material. This energy input or release is quantified by a physical property called the heat of vaporization, usually defined as the number of calories required to vaporize one gram of liquid or the number of BTUs required to vaporize one pound of liquid. The vaporization and/or condensation of water are frequently-encountered processes in energy-related considerations, and water’s heat of vaporization

is uniquely large, with a value of about 540 calories per gram or 970 BTU per pound.

Freezing and melting also must be considered. Melting a solid object requires input of energy to the object, and freezing requires removal of energy from the object. This input or removal of energy is quantified by a physical property called the heat of fusion, usually defined as the number of calories required to melt one gram of frozen material or the number of BTUs required to melt one pound of frozen material. The heat of fusion of water is 79.7 calories per gram or 144 BTU per pound.

Vaporization/condensation and melting/freezing are constant-temperature processes. Therefore, if heat is applied to a solid at an initial temperature below its melting temperature, the temperature will rise to the melting temperature, stay at that temperature until all of the material melts, increase (while the material remains a liquid) until the vaporization temperature, stay at that temperature until all of the material vaporizes, then increase in temperature while the material remains a vapor (see Figure 2-1). Water heated above its vaporization temperature is very important in steam power plants and is called superheated steam.

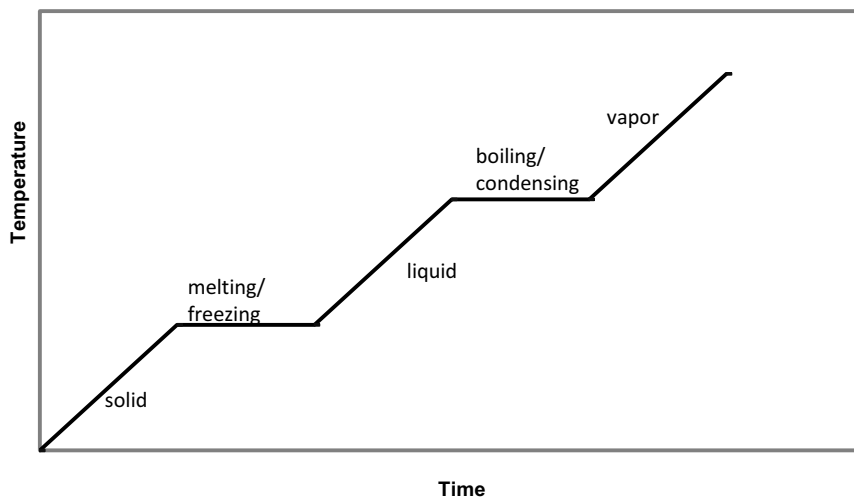

Figure 2-1. Temperature Variation of a Heated Object

Transferring heat from one material to another occurs in many energy-related processes. Heat transfer is an engineering discipline with great depth and complexity, but understanding the three mechanisms of heat transfer suffices for the development of an understanding of energy fundamentals. The three heat transfer mechanisms are conduction, convection, and radiation, defined as follows:

Conduction: Transfer of heat through a stationary material as a result of a temperature difference within the material.

Convection: Transfer of heat through a fluid as a result of internal movement of the fluid.

Radiation: Transfer of heat as a result of emission, propagation, and absorption of electromagnetic radiation.

The familiar concept of temperature arises often in thermal energy considerations. The two common temperature measures are the Celsius scale and the Fahrenheit scale. The following formulas permit conversion between these scales:

$$T(^{\circ}\text{F}) = 1.8 \times T(^{\circ}\text{C}) + 32 \quad (2-6)$$

and

$$T(^{\circ}\text{C}) = [T(^{\circ}\text{F}) - 32] / 1.8 \quad (2-7)$$

where

$T(^{\circ}\text{F})$ = temperature in degrees Fahrenheit

$T(^{\circ}\text{C})$ = temperature in degrees Celsius

The concept of absolute zero temperature also arises in thermal energy considerations.

Molecular motion in a material depends on temperature, with greater motion at higher temperatures. Absolute zero is the temperature at which

all molecular motion stops. Temperatures below absolute zero are impossible. Absolute zero temperature occurs at approximately -459.67 degrees Fahrenheit and -273.15 degrees Celsius. Two additional temperature scales have been created to facilitate working with absolute temperatures. They are as follows:

$$\text{Kelvins} = ^\circ\text{C} + 273.15 \quad (2-8)$$

$$\text{Degrees Rankine} = ^\circ\text{F} + 459.69 \quad (2-9)$$

Note the special case of the kelvin designation instead of degrees Kelvin. This special consideration was created in honor of Lord Kelvin, a pioneer in thermal energy physics.

2.5.3 Chemical Energy

Chemical elements are held together by forces to form molecules. When a chemical reaction takes place, molecules combine and/or dissociate (split apart) to form new molecules. If the forces holding the new molecules together are smaller than the forces holding the original molecules together, energy is liberated in the form of heat. This is what happens when an object burns (combines with oxygen). There is a quantity of thermal energy released for every pound (or gram) of combustible material that burns, and it is specific for each different material.

Materials that are suitable for use as fuels or as materials that can be converted into fuels include carbon, hydrocarbons, carbohydrates, alcohols, esters, and ethers. The chemistry of these materials and the transformations that can occur in them are complex matters that have occupied chemists for many years. As noted above, when these materials burn, energy is released. Oxides of carbon (carbon dioxide in complete oxidation and carbon monoxide in incomplete oxidation) and water (in the combustion of compounds containing hydrogen) are formed.

A measure of the usefulness of a fuel is its heating value, the energy released when the fuel burns (see Appendix C). Heating value is expressed in units

of energy per unit weight or mass, commonly BTU per pound or calories per gram. It is necessary to specify two different heating values for a fuel, depending on the state (liquid or vapor) of the reaction products. The burning of hydrocarbons, carbohydrates, or alcohols produces water and carbon dioxide. Carbon dioxide is a gas at the normal operating temperatures of energy processes, but water may exit the reaction as a vapor or a liquid. Since energy is required to go from a liquid to a vapor, more energy is available for release when the water produced is in the liquid state. The High Heating Value (HHV) is applicable to processes whose final temperature causes the water produced to be liquid. The Low Heating Value (LHV) applies when the water produced is a vapor. For example, gasoline has a High Heating Value of 125,071 BTU per gallon and a Low Heating Value of 115,500 BTU per gallon. Appendix C gives heating values for important fuels.

2.5.4 Electrical Energy

Electricity is the flow of an electrical current due to a voltage difference. Electricity is a convenient means for transporting energy but is not an energy source *per se*. Electricity is an energy carrier. An important and unique feature of electrical energy is there must be an exact balance between the production of electricity and the use of that electricity. Balancing production with demand is a continuous requirement in electrical grids.

Atoms have electrical charges on their nuclei, and the electrons swarming around the nucleus have electrical charges on them. The charge on the nucleus and the electron charge differ in that they attract one another. For labeling purposes, we say the nucleus is positively charged, and the electrons are negatively charged.

Electricity is simply the motion of charges. Since this charge motion can be transformed into mechanical, chemical, or heat energy, it is very important as an energy carrier.

Electrical energy is closely related to magnetism. Both produce fields. A field is a region influenced by a force. Placing a magnet beneath a sheet of

paper on which iron filings are dispersed is a familiar demonstration of a magnetic field.

Electricity can be produced in a conductor by a time-varying magnetic field. As might be expected, the reverse process also occurs. Magnetism can be produced by time-varying electric charges (an electric current). An electromagnet is simply an iron rod or bar wrapped in a coil of wire through which an electrical current is flowing.

Electric generators are machines that move a conductor through a magnetic field. The principle is easily demonstrated by passing a copper wire between the poles of a horseshoe magnet (see Figure 2-2). This phenomenon is manifested in huge machines that generate millions of watts of electricity, but the basic idea is still relative motion between a conductor and a magnetic field.

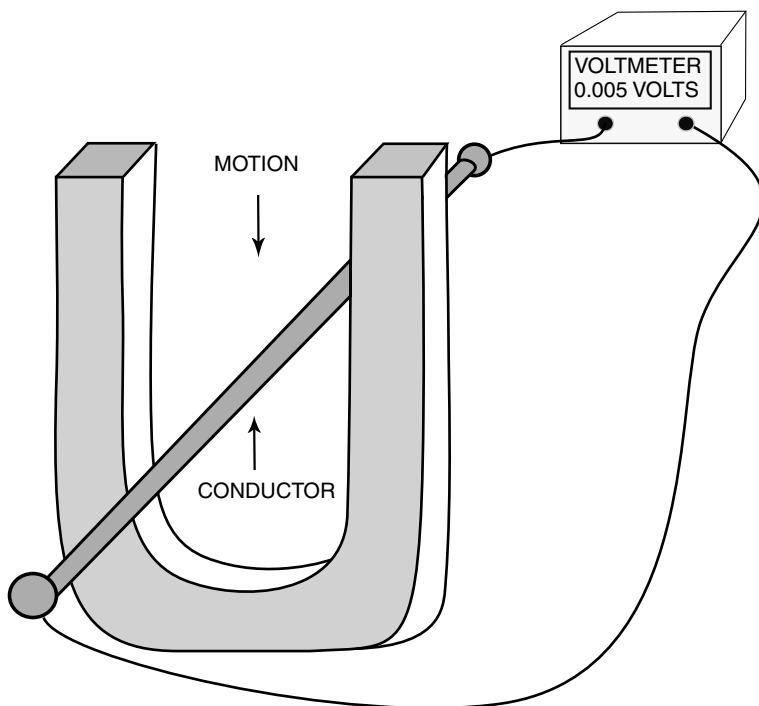

Figure 2-2. A Simple Electric Generator

Electricity is quantified by four main measures:

- Electromotive Force (EMF) is a measure of the force that causes electrical charges to flow.
- Current is a measure of the rate at which electrical charges flow.
- Resistance is a measure of a material's tendency to retard the flow of electric current.
- Electrical power is the rate at which the electrical energy flows as a result of an electrical current.

The common units of measure for these quantities are volts for EMF, amperes for current, ohms for resistance, and watts for power. Their interrelationships are given as follows:

$$I = V/R \quad (2-10)$$

$$P = V \times I \quad (2-11)$$

where

- I = current in amperes
- V = EMF in volts
- R = resistance in ohms
- P = power in watts

The way to think about this is as follows: Voltage causes current to flow. The magnitude of the current due to a voltage is determined by the resistance of the material through which the current flows. The power is the consequence of the current flow.

Example 2.4

Consider a 100-ohm resistor connected to a six-volt battery. The current flowing in the circuit is $6/100 = 0.06$ amperes. The power dissipated (converted into heat) in the resistor is $6 \times 0.06 = 0.36$ watts.

Batteries and capacitors are energy storage devices. Batteries function by the conversion of stored chemical energy to electrical energy and vice versa (in the case of rechargeable batteries). Capacitors function by the storage of electrical charges on conductors separated by a non-conducting material called a dielectric. When a direct current voltage is applied to a capacitor, a positive charge builds up on one conductor, and a negative charge builds up on the other. When the voltage is removed, the charges remain. When the two sides of a charged capacitor are connected through a conductor, the stored charges flow through the conductor. Batteries and capacitors are useful for storing electrical energy when it is available and delivering the electricity when it is needed.

2.5.5 Electromagnetic Energy

Electromagnetic (EM) energy is visible light and its close relatives such as infra-red light, ultra-violet light, and x-rays. An example is the heating effect of the sun's rays. This is heating due to electromagnetic radiation that travels at very high speed (186,000 miles per second) from the sun to you. The radiation is absorbed by your skin and results in heating.

Electromagnetic energy is somewhat harder to visualize than other forms of energy, but knowledge about its characteristics is well established. Light and other forms of EM energy travel in packets of oscillating electric and magnetic fields. These energy packets, called photons, constitute the sunlight that makes life possible on earth. All other forms of EM energy also travel in photons.

Since the fields oscillate, photons may be characterized by their frequency of oscillation or, correspondingly, their wavelength. Each photon carries a fixed amount of energy that depends on its frequency. These photons travel through space (including vacuums) indefinitely until they interact with mat-

ter. Photons can interact with electrons in atoms, and, in so doing, transfer energy to the electron. An important phenomenon is the transfer of an amount of energy sufficient to cause the electron to escape from the atom. This is called the photoelectric effect, a phenomenon that is exploited in solar cells.

2.5.6 Nuclear Energy

While chemical reactions involve the electrons that swarm around atomic nuclei, nuclear reactions involve the nuclei themselves. Certain heavy nuclei (those with high atomic mass) can be made to split apart (fission), and this process releases energy. Certain light nuclei (those with a low atomic mass) can be made to join together (fusion), and this also releases energy. The energy released in a fission or fusion reaction is due to a transformation of mass into energy.

The conditions, materials, and arrangement needed to make a practical energy-producing fission reactor are well-known, practical, and in routine use. Achieving the conditions, materials, and arrangement for a practical fusion reactor is much more difficult, and a practical energy-producing fusion reactor has not yet been built.

Radioactive nuclei spontaneously undergo transformations that yield new daughter nuclei and emissions, usually alpha particles, beta particles, or gamma rays. These products of radioactive decay possess kinetic energy that degrades to thermal energy by interaction with matter. If the matter is human tissue, then ionization by the radiation can cause cell damage, and disease may result. If the matter is the material deep within the earth, then geothermal heating occurs.

2.5.7 Relationships Between Energy Forms

Practical energy processes almost always have heat and/or mechanical energy as the desired end products. There are exceptions, such as lighting, electrolysis, and electroplating, but these processes are much less significant parts of total energy use than heat and mechanical energy.

Example 2.5

Consider an elevator that is driven by a motor that is connected to an electric grid powered by coal-burning power plants. The following five transformations take place, from the chemical energy initially stored in the coal to the desired end product, raising the elevator:

1. *Chemical to thermal (burning the coal)*
2. *Thermal to kinetic (in the steam turbine)*
3. *Kinetic to electric (in the generator)*
4. *Electric to kinetic (in the elevator's motor)*
5. *Kinetic to potential (raising the elevator)*

Another important example is the hydrogen-powered car. Free hydrogen does not exist in nature. It can be made by processing hydrocarbons or carbohydrates or by processing water by electrolysis. Hydrogen from water is probably the process that will be used if hydrogen use ever becomes commonplace in energy systems. Electrical energy is used to break the chemical bonds holding hydrogen and oxygen together in water, thereby creating stored energy in the hydrogen. Hydrogen provides energy storage and energy transport capabilities. Hydrogen certainly has a potential for widespread use in the energy enterprise, but it clearly is an energy carrier, not an energy resource. (See Chapter 12.)

2.6 Energy Utilization

Obtaining energy in a useful form usually involves transforming an available form of energy into the desired form of energy.

Heat is obtained by the transformation of other forms of energy. Processes for obtaining heat range from standing in the sun (transforming electromagnetic energy into heat energy) to the combustion of hydrocarbons (transforming chemical energy into heat energy) to nuclear fission or fusion

(transforming nuclear energy into heat energy). The heat may be used directly or for inducing desired changes in material properties.

Engines are devices for obtaining mechanical work from a non-mechanical energy source. For example, an electric motor is an engine for obtaining mechanical work from electric energy.

Heat engines are devices for obtaining mechanical work from heat energy. The development of heat engines made the industrial revolution possible, and they are essential for maintaining modern society. In heat engines, mechanical work is obtained by motion that is induced by a pressure difference which is, in turn, induced by appropriate heating and cooling. The main types of heat engines are internal combustion piston engines and internal and external combustion turbines (Stirling engines, a type of external combustion piston engine previously used infrequently, may yet see increased use in solar power systems).

Consider an internal combustion piston engine. It consists of one or more cylinders, each containing a piston and a means for injecting fuel and air and achieving ignition by a spark or by heating caused by vapor compression when the piston is near the closed end of the cylinder (see Figure 2-3). The resulting explosion results in high temperature gaseous combustion products. This creates high pressure on the face of the piston. Since the opposite side of the piston experiences lower pressure, the pressure difference drives the piston away from the closed end of the cylinder. The piston is connected to a crankshaft and delivers mechanical energy to it. In automobile engines, the mechanical energy propels the car, provides energy for operating accessories, and provides energy for venting combustion gases and for compressing the fuel-air mixture.

Now consider the steam or gas turbine. A turbine is essentially a set of fan blades mounted on a shaft. Shaft rotation is induced by fluid flowing through the turbine. For steady operation, a constant pressure difference must be maintained across the turbine. In a steam turbine, heat is supplied to vaporize water (and possibly further heat it into a superheated condition) on the upstream side, and cooling is supplied on the downstream side to

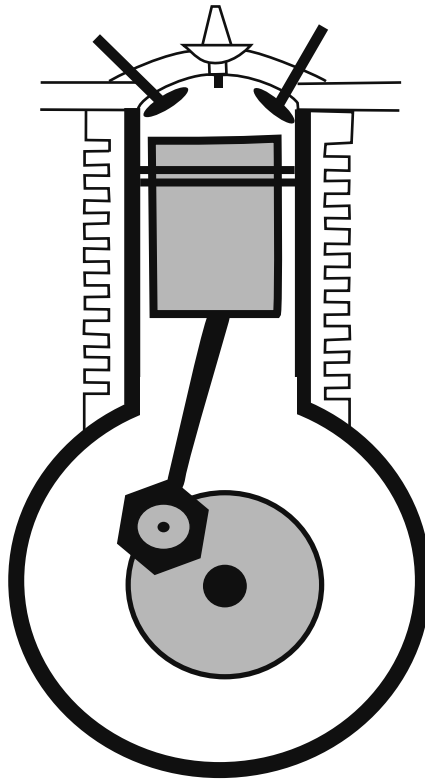

Figure 2-3. Cylinder of an Internal Combustion Engine

condense the steam that exits the turbine. This provides the pressure difference that induces steam flow through the turbine. Gas turbine operation is similar. Heat energy is supplied to a gas on the upstream side of the turbine. The downstream pressure is maintained at a lower pressure by venting to the atmosphere or by cooling the exhaust gas.

Jet engines are turbines in which fuel combustion occurs within the engine. Hot gases resulting from combustion provide thrust upon exiting the engine. In turbojet and turbofan jet engines, the exhaust gas drives a turbine that is mounted on the same shaft as a compressor at the engine entrance.

A third type of heat engine is the Stirling engine. The Stirling engine can use any high temperature heat source to power the engine. The initial invention of the Stirling engine occurred in the early nineteenth century,

but its implementation has been limited. However, implementation may now increase because it is well-suited for use as a component of solar heat engines. The basic idea of a Stirling engine is to cause a contained gas to move back and forth between a heated section and a cooled section. Pistons in each section turn a flywheel whose angular momentum serves to keep the process going when energy is not being delivered by the pistons. Since Stirling engine operation is somewhat involved, a discussion of operating principles appears in Appendix D.

Heat engines that operate with the working fluid circulating in a closed loop are called closed-cycle heat engines (such as Stirling engines or steam turbines), and those that exhaust the working fluid after one pass through the system are called open-cycle heat engines (such as automobile, truck, and jet engines).

The common use of the output of a heat engine is to drive a generator. Large electric generators used in power plants are machines that create electricity by rotating conductors through a magnetic field. Figure 2-4 shows the rotating portion of a large steam turbine that is used to drive a generator in an electric power plant.

2.7 Energy Efficiency

Many processes that are essential to modern civilization involve the conversion of energy from one form to another. Kinetic energy is transformed into electrical energy by a generator, electrical energy is transformed into kinetic energy by a motor, chemical energy is transformed into electrical energy by a battery, etc. In all these transformations, the desired transformation is always accompanied by a second (usually undesired) transformation into heat, with the attendant release of this heat energy to the environment. This heat can sometimes be put to use (space heating or water heating with waste heat is sometimes done), but it is usually considered waste to be disposed of. It must be concluded that heat energy is less valuable for practical applications than the other forms of energy.

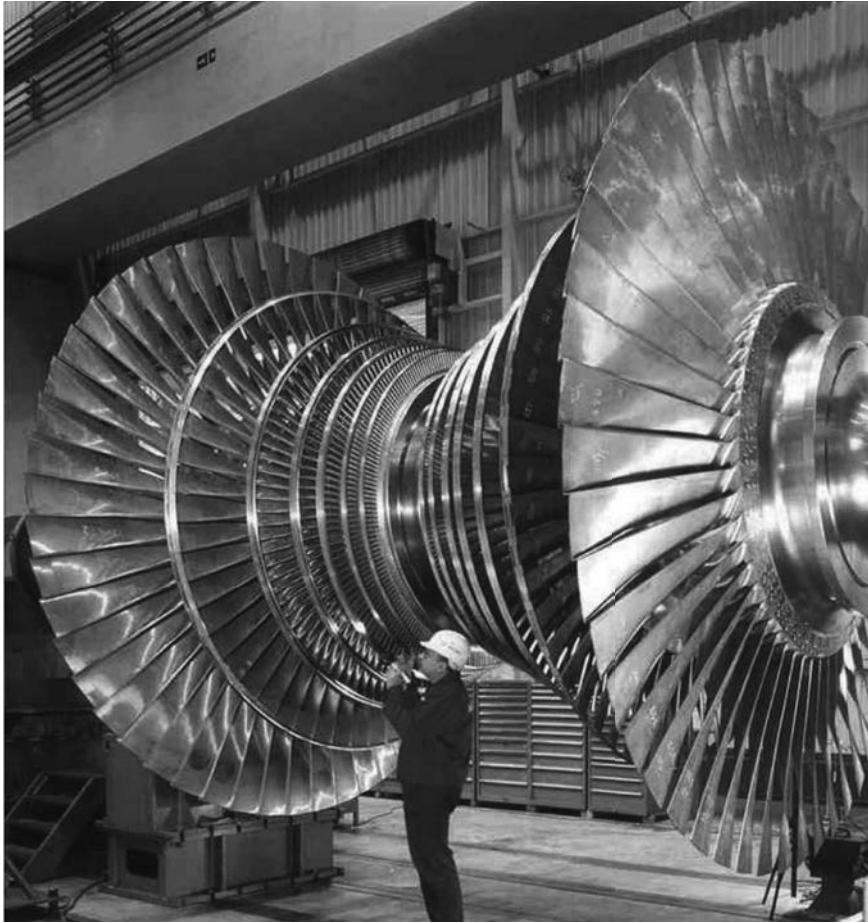

Figure 2-4. Internals of a Large Steam Turbine (courtesy of Siemens)

Furthermore, while other forms of energy can be transformed entirely into heat energy, it is not possible to transform heat energy entirely into one of the other forms of energy. In addition, the heat remaining after a partial transformation into another form of energy is less useful than was the heat initially. Operation of heat engines always results in only part of the heat energy being converted into mechanical energy, with the rest of the energy being dissipated as lower grade energy (heat). The efficiency of a heat engine is defined as the fraction of the heat energy applied that can be converted into mechanical energy. A very simple and useful principle reveals the maximum efficiency with which thermal energy can be converted into mechanical energy. The maximum possible efficiency is given by the following:

$$e = (T_h - T_c) / T_h \quad (2-12)$$

where

- e = maximum efficiency
- T_h = absolute temperature at which heat is added to the system
- T_c = the absolute temperature at which heat is removed from the system

Example 2.6

Consider a heat engine in which the heat is added at 500 °C and heat is removed at 0 °C. Conversion to absolute temperatures gives $T_h = 500 + 273 = 773$ kelvins and $T_c = 0 + 273 = 273$ kelvins. The maximum achievable efficiency is given by

$$e = (773 - 273) / 773 = 0.65$$

Practical heat engines have lower efficiencies than the maximum efficiency because of energy losses within the system.

2.8 Energy Balances

Acquiring, processing, storing, and transporting fuels require an expenditure of energy. A measure of the value of a fuel is the energy available from using the fuel compared to the energy required to get that fuel. The “energy balance” for fuels is expressed in several different ways, reflecting the preference and purpose of the analyst involved. Here, a measure called the Energy Ratio will be used to illustrate the concept. It is defined as follows:

$$\text{Energy Ratio} = (\text{Energy available in fuel}) / (\text{energy consumed in getting fuel})$$

Even this simple definition may have different interpretations. For example, the energy balance may or may not include factors such as energy expended to transport or store the fuel or raw material used to produce the fuel.

If the energy ratio is less than one, more energy is consumed in all of the activities required to get the fuel than can be obtained by burning the fuel. Large values of energy ratio are desirable.

A refinement of the energy ratio concept takes into account the “value” of the energy used in getting the fuel versus the “value” of the fuel. For example, liquid fuels are said to be more “valuable” than solid fuels because of their transportability and ease of use, and using domestic energy for getting fuel is said to be more “valuable” than using imported energy.

Since the concept of energy balance is most often used in assessing liquid fuels, it is informative to consider only the consumption of liquid fuels in producing liquid fuels. To maintain clarity, we define the Liquid Energy Ratio as follows:

$$\text{Liquid Energy Ratio} = \frac{\text{(Energy available in liquid fuel produced)}}{\text{(energy consumed from liquid fuel in getting produced fuel)}}$$

2.9 A Little Chemistry

2.9.1 Atomic Structures

As has been mentioned, atoms consist of a central nucleus surrounded by electrons. The nucleus is composed of protons and neutrons (except in the case of hydrogen which lacks neutrons in its most common isotopic form). Protons and electrons are electrically charged, and neutrons are electrically neutral. The arbitrarily adopted convention on electrical charge is positive for protons and negative for electrons. An atom has equal numbers of protons and electrons, rendering the atom electrically neutral.

Electrons form a fast-moving cloud of negatively-charged particles around the central nucleus. The attraction of the positively-charged nucleus prevents the electrons from flying away. The electrons can possess only discrete energies, and the number of electrons in each energy state is limited. The allowable energy states are called shells. For example, the maximum num-

ber of electrons in the lowest energy shell, which is closest to the nucleus, is two. The second shell is populated after the first shell is full and contains up to eight electrons. Additional shells, each with its own maximum electron population, contain the remaining electrons in the atom. The most stable (chemically inert) atoms are those whose outer shells are filled to the maximum allowable electron population.

2.9.2 Molecular Structures

Atoms combine to form molecules. Molecules may be combinations of atoms of the same type or of dissimilar atoms. The formation of molecules depends on the outer electrons in atoms, called the valence electrons. If the number of valence electrons is less than the maximum number that the outer shell can hold, the atom can interact with other available atoms to increase or decrease the outer shell electron population to achieve a filled outer shell.

Electrons may be taken from or given to other atoms to provide filled outer shells. These bonds are called ionic bonds. Electrons may also be shared between participating atoms to provide filled outer shells. These bonds are called covalent bonds.

The chemical properties of compounds depend on the arrangement of atoms in the molecules as well as on the atomic composition of the molecules. Molecules may be linear, branched, or ring-shaped. Larger molecules have complex three-dimensional shapes. Chemists have devised diagrams for depicting molecular structures. These diagrams may simply show the connections between atoms in the molecules or they may show the three-dimensional configurations. See Figure 2-5 for some diagrams that show the connections between the atoms in selected molecules.

Molecules with the same composition but different arrangements of atoms are called isomers. For example, consider propanol, an alcohol with three carbon atoms. Figure 2-6 shows the two isomers of propanol, one with an OH group attached to an end carbon atom and the other with an OH group

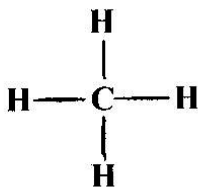

Methane

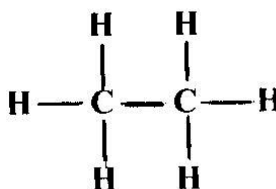

Ethane

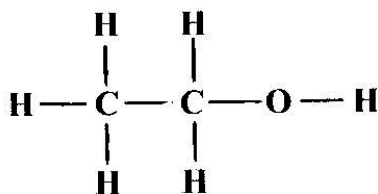

Ethanol

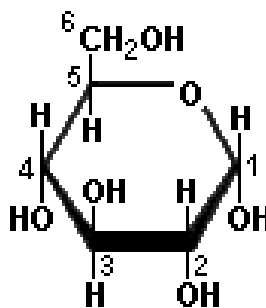

Alpha-D Glucose
(The building block for
starch and cellulose)

Figure 2-5. Some Molecular Structures

attached to the middle carbon atom. Larger atoms have the possibility of multiple isomers, all with the same composition but different properties.

2.9.3 Chemical Separations

Processing raw materials to obtain desired liquid fuels often involves separating the components of a mixture. The most important separation technologies in producing liquid fuels are distillation and solvent extraction.

Distillation uses differences in the boiling points of the components of a mixture to separate them. Petroleum processing and alcohol production

**1-Propanol****2-Propanol**

Figure 2-6. Structures of Propanol Isomers

rely on distillation to yield desired products. Heating a mixture of volatile components yields a vapor that is richer in the component with the lower boiling point. Greater differences in the boiling points of the constituents result in higher concentration of the low boiling point component or components in the vapor.

Sometimes, the vapor is rich enough in the desired product that condensation of the vapor achieves the desired separation. However, the boiling point differences are often insufficient to yield a pure enough product. To obtain a pure enough product, one might consider further purification by condensing the vapor, then heating the resulting liquid to induce vaporization of the new mixture, which is already richer in the low boiling (that is, low boiling point) component. Repetition of the vaporization/condensation cycle yields greater and greater separations.

Repetitive vaporization and condensation can be accomplished in a single system, called a fractional distillation column. In such a column, there is a steady downflow of condensed liquid and an upflow of vapor in contact

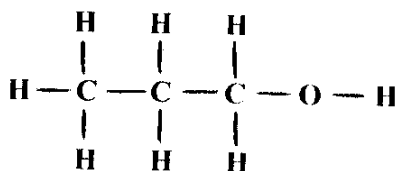
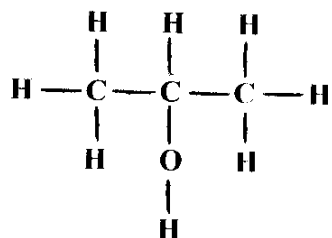
with one another. Separation of multiple components in a mixture may be accomplished by withdrawing material at different locations along the column.

Solvent extraction involves moving a dissolved chemical from one solvent to another. The dissolved substance will distribute itself between two solvents according to its solubility in those solvents when the two solvents are mixed. Moving the dissolved substance into a new solvent creates new opportunities for further processing.

2.9.4 Isotopes

The chemical properties of an element are determined by the number of electrons in the atom, which equals the number of protons in the nucleus. The nucleus, however, contains neutrons as well as protons. These neutrons do not have much effect on chemical properties, but they do affect nuclear properties, most notably radioactivity and the tendency to undergo nuclear reactions such as neutron absorption. Atoms with the same number of protons but differing numbers of neutrons are called isotopes. Some isotopes occur in nature, and many others are produced in nuclear reactors.

2.9.5 Catalysts

Catalysts are substances that facilitate chemical reactions without being consumed in the process. A catalyst can speed reactions that would proceed slowly or not at all in the absence of the catalyst. Specific reactions require specific catalysts. Finding effective and practical catalysts to facilitate desired chemical reactions is often the deciding factor in determining the viability of a process.

Catalysts can provide selectivity when two or more reactions are possible among the chemicals present. The physical state of the catalyst can influence selectivity. For example, pore sizes in catalysts can be controlled, and this allows smaller molecules to enter the pores and to interact with the catalyst while larger molecules are excluded.

2.9.6 Electrochemistry

Electrochemistry deals with the conversion of chemical energy into electrical energy and with chemical reactions that occur because of an electric current.

Batteries use fixed quantities of chemical reactants to produce electricity, while fuel cells use constantly replenished quantities of reactants. Fuel cells can operate with hydrogen or methane and oxygen (from air) as reactants. Fuel cells are under consideration for mobile applications in vehicles and in stationary applications for local electricity production. New systems are available that provide enough locally-produced electricity to reduce or eliminate the need for electricity from the grid. However, the fuel of choice for these systems, natural gas, still produces carbon dioxide (a greenhouse gas) when used in a fuel cell.

Application of an electric voltage across a fluid can cause compounds in the fluid to dissociate. This process is called electrolysis. The separation of the hydrogen and oxygen in water is a special case of electrolysis. The reaction may be represented as follows:

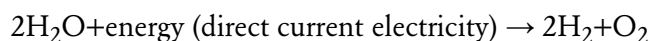

Electrolysis is a potential method for producing large quantities of hydrogen for use in future energy systems.

Electrolysis is also important in producing certain chemicals, including sodium, potassium, chlorine, fluorine, and aluminum.

Electrolysis is the basis for electroplating, the deposition of metals on an electrode. The process usually involves the deposition of precious metals on less valuable substrates.

Electrochemical reactions also result in the corrosion of metals, as in the formation of rust on iron.

Electrolysis is a potential option for producing materials with processes that are now dependent on energy from fossil fuels. Industry may find it advantageous to switch to greater use of electrical energy in its processes. The electrification of industry will stimulate research to find new, economical ways to produce materials by electrolysis. For example, conversion of iron ore into iron metal by electrolysis has been demonstrated in laboratory work, and efforts to develop economical, large-scale processes are under way.

2.10 A Little Biology

2.10.1 Introduction

Biology is the science of living things: plants and animals. For energy considerations, plant biology is the issue of greatest interest. Plants manufacture biomass, an assortment of compounds composed mostly of carbon, hydrogen, and oxygen. Biomass can produce heat energy directly by burning, but the current main focus is on converting biomass into liquid or gaseous bio-fuels because of their portability.

2.10.2 Photosynthesis

Photosynthesis is the process by which plants use energy from the sun to convert water and atmospheric carbon dioxide into carbohydrates. The electromagnetic energy in sunlight is converted into chemical energy stored in the plant matter. The biochemical processes in photosynthesis are complex, but the net reaction is as follows:

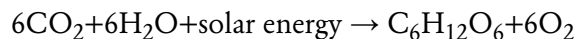

The product shown in this reaction is a simple sugar. Further biochemical reactions convert these simple sugars into larger organic molecules.

The continual replacement of carbon dioxide with oxygen in the atmosphere by photosynthesis is essential for animal life.

The photosynthesis reaction begins with absorption of solar photons by chlorophyll, the green pigment in plants. However, chlorophyll can use only light with certain wavelengths. Green light is reflected (that is why plants look green to us). Chlorophyll is able to use photons with wavelengths that are lower or higher than the wavelength corresponding to the color green. Plants can use only a portion of incoming solar energy because of this selectivity, because of inhibition of photosynthesis by plants in excessive sunlight, because of an inadequate or excessive water supply, because of inadequate trace minerals needed for plant growth, and because of shading from the upper parts of the plant. Typical farm plants grown in America can use one to two percent of incident solar energy, but some plants are much more efficient than others.

One of the major factors in determining plant growth rates is the concentration of carbon dioxide. Plants grow much faster in a CO₂-rich environment.

Algae, simple plants that grow in water, are also a potential source of material for energy production. Algae are fast-growing, and some produce large quantities of oils that can serve as fuel.

2.10.3 Carbohydrates and Energy Storage

When biomass burns, the carbohydrates undergo a reaction that is the reverse of the photosynthesis reaction. For example, oxidation of hexose sugar, a simple carbohydrate, proceeds as follows:

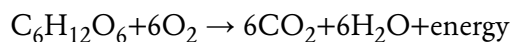

The energy released in this reaction is equal to the energy initially received by the plant during photosynthesis to create that quantity of biomass.

2.10.4 Oils and Energy Storage

Plants also produce oils. Chemically, these oils are compounds called triglycerides (see Appendix L). Triglycerides are compounds with a three-carbon spine to which are attached long chains of fatty acids. Fatty acids are

chemical structures composed of carbon chains with hydrogen attached to all of the carbon atoms except for one carbon connected to a hydroxyl radical (a hydrogen-oxygen combination). Triglycerides will burn, resulting in conversion of the carbon and hydrogen atoms into carbon dioxide and water. Some terrestrial plants and some algae produce oils that can serve as fuel.

2.10.5 Enzymes

An enzyme is a specialized protein molecule that enables or hastens a biochemical reaction without being consumed in the process. In chemical terms, an enzyme is a form of catalyst.

2.10.6 Biofuels from Biomass

As we shall see in Chapter 7, the carbon and hydrogen (and sometimes the oxygen) in biomass can be converted into other compounds, mainly hydrocarbons and alcohols. Oxidizing these compounds releases chemical energy in the form of heat energy (and, of course, a small amount of electromagnetic energy in the form of light). However, it is very important to remember these compounds can release no more energy than was initially absorbed from sunlight.

2.11 Linear vs. Exponential Growth

An intuitive feel for the impact of exponential, rather than linear, change is important in assessing future energy requirements and the adequacy of various energy resources.

Many people tend to think that changes occur in a linear fashion. In linear growth, the rate of growth is proportional to the *initial* value of whatever is being considered. It is natural to think that an increase in some quantity that is observed in one year will repeat in the following year. In exponential growth, the rate of growth is proportional to the *current* value of whatever is being considered. That is:

$$dQ/dt = aQ \quad (2-13)$$

where

- Q = the quantity under consideration
- dQ/dt = the rate of change of the quantity under consideration
- a = a constant

The solution of this differential equation is:

$$Q = Q_0 e^{at} \quad (2-14)$$

where

- Q_0 = initial value of the quantity under consideration

It can be shown that the time required to double the quantity under consideration is given by

$$t_d = 0.693/a \quad (2-15)$$

where

- t_d = doubling time

Note that the rate of increase also doubles when the quantity under consideration doubles.

Intuition often fails in assessing changes in processes that grow exponentially. Consider the following examples:

Example 2.7

A city with a population of 1 million had a population growth of two percent or 20,000 people in the first year of our accounting. If the subsequent growth were linear, the population would double in 50 years. On the other hand, exponential growth would result in a doubling of population in 35 years, and the rate of increase would be 40,000 per year at that time. Exponential growth usually applies to populations

because birth rates are proportional to the current population, not some previous population.

Population, oil consumption, computer speed, and U.S. automobile production are examples of quantities that grew exponentially during at least part of their histories. Many people fail to appreciate how much faster things change in exponential growth compared to linear growth. One important case is assessing oil consumption. We will see in Chapter 4 that $1/3$ to $1/2$ of the oil originally in the ground has been used in the last hundred years, and that growth in consumption has been exponential. If the exponential growth continues, the remaining oil will be consumed much faster.

2.12 Energy Information on the Internet

Internet sources include a wealth of information on energy and its use. In fact, the quantity of information is a bit overwhelming. This book is an attempt to collect and organize energy information in a way that facilitates an efficient journey to an understanding of the subject. Nevertheless, it is anticipated that many readers will want to dig deeper. Some of the most important energy-related websites are listed below. They contain useful information and provide Internet links to the rest of this huge resource. The energy-related websites include official government-sponsored sites, sites sponsored by non-profit interest groups such as technical societies and universities, sites operated by advocates of various energy technologies and policies, and sites operated by energy-related businesses. A few of the most important websites are shown below. A more complete list of energy-related websites appears in Appendix E.

<http://www.whitehouse.gov/energy> is the website for the National Energy Policy.

<http://www.energy.gov> is the U.S. Department of Energy website. This site contains links to a wealth of energy-related sites, for DOE facilities and for external links. Key DOE sites are for the Energy Information Administra-

tion at <http://www.eia.doe.gov> and for the Office of Scientific and Technical Information at <http://www.osti.gov>. The USDOE also supports energy centers in the national laboratories and some universities, each with their own websites, which can be found through the main DOE website. One such laboratory is the National Renewable Energy Laboratory: <http://www.nrel.gov>.

<http://www.usda.gov> is the U.S. Department of Agriculture website. This site contains links to sites with information about biofuels.

The U.S. Geological Survey, a branch of the U.S. Department of the Interior, maintains a website at <http://www.usgs.gov>. It contains information about energy resources.

<http://www.worldwatch.org> is the website for the Worldwatch Institute, an organization that assesses worldwide challenges, including energy availability.

The World Energy Council (WEC) is an organization concerned with energy issues throughout the world. The WEC is said to be UN-accredited, non-government, non-commercial, and non-aligned. Its website is <http://www.worldenergy.org>.

British Petroleum compiles and disseminates a wealth of useful energy statistics. The BP website is <http://www.bp.com>.

<http://www.newamericancentury.org> is the website for a conservative organization that takes a stand on various issues. One such issue is U.S. military strategy. This pertains to energy policy in that use of U.S. military power to ensure the continued availability of foreign oil is not inconceivable to some who possess political power.

<http://www.nrdc.org> is the website for the Natural Resources Defense Council, an environmental group whose agenda includes energy issues.

2.13 Energy Facts vs. Energy Fiction

There is a large body of useful and valid information about energy production and consumption available to the interested reader. But there are also sources that provide misinformation. One must exercise caution in accepting “facts” presented in the literature or on the Internet.

Exercises

- 2-1. A force of 10 Newtons is applied to a mass of 10 grams. What would be the acceleration of the mass? (Express results in meters/sec² and in ft/sec².)
- 2-2. A 3,000-pound car is brought to a stop from 40 miles per hour by regenerative braking. How much energy is transferred to the braking system? (Express results in foot pounds, BTUs, and Joules.)
- 2-3. A man has a mass of seven slugs. What does he weigh on the surface of the earth (in pounds and in Newtons)?
- 2-4. How many BTU per hour of electricity are delivered by a power plant that delivers 1,000 megawatts of electricity?
- 2-5. How much energy (in BTUs and kilowatt hours) is required to increase the speed of a 100-pound object from 10 feet per second to 20 feet per second?
- 2-6. A 100-pound object is dropped from a height of 10 feet. How fast is it traveling when it hits the earth? (Ignore air resistance.)
- 2-7. 100 pounds of 70°F water and 100 pounds of ice are each heated to produce 100 pounds of steam. Compare the energy required for each process.

- 2-8. How much current is used to power a 1-watt light bulb with a 9-volt battery?
- 2-9. A radioactive material decays exponentially. The radiation drops to half of its initial value in one week. What fraction of the initial radioactivity will remain after eight weeks?
- 2-10. All heat engines rely on pressure differences to achieve gas flows. Discuss the relation between this fact and the efficiency of converting heat energy to mechanical energy.
- 2-11. A coal-fueled power plant produces 1,000 megawatts of electricity in winter when the cooling water fed to the condenser is at 50°F. Estimate the power production in summer when the cooling water temperature is at 80°F.
- 2-12. A rectangular bathtub is four feet long and two feet wide. Water is heated from 60°F to 120°F in an electric water heater. How much energy (in BTUs and in kw-hours) is required if the tub is filled to a depth of six inches? What is the cost for energy to fill the tub if electricity costs 11 cents per kilowatt hour? Assume no energy loss within the system.
- 2-13. A thermal power plant operates at 35 percent efficiency and produces 1,000 megawatts of electricity. The waste heat is dumped into a river flowing at 50,000 cubic feet per second. Estimate the temperature rise in the river.
- 2-14. An inventor submits a proposal to a government agency for funding to develop a car that uses water as a fuel. He proposes using a hydrogen fuel cell to produce electricity to be used both for propulsion and for producing the hydrogen used in the fuel cell. Should he receive the funding? Why or why not?

3

**Energy
Production and
Consumption**

The Main Points

- World energy consumption in the early twenty-first century was around 500 Quads per year.
- The U.S. has long been the largest energy consumer in the world, but was surpassed by China in 2009 when each country accounted for around 20 percent of world energy consumption.
- U.S. energy consumption in the early twenty-first century was around 100 Quads per year.
- In the early twenty-first century, imports provided around 30 percent of total U.S. energy and over 60 percent of oil and oil derivatives consumed in the U.S. (costing the U.S. around a billion dollars a day).
- U.S. oil production has been declining since around 1970.
- Unconventional oil (oil sand and oil shale) reserves are large, but they face economic and environmental issues.
- Large natural gas reserves exist in the U.S. Most of this gas requires advanced extraction methods, usually the fracturing of underground gas-bearing rock formations (called hydrofracturing or fracking).
- Coal is plentiful but dirty.
- Nuclear power can furnish a significant fraction of electrical energy production without greenhouse gas emissions, but it is controversial because of safety concerns.
- America gets around 85 percent of its energy from fossil fuels. All fossil fuels release carbon dioxide into the atmosphere when used for energy production.

3.1 Overview

This chapter addresses levels of energy production and consumption in the past and present. Understanding where we are and how we got here is crucial in defining the changes necessary to achieve energy sustainability. Later chapters will address the possibilities for future energy production and consumption.

Statistics do not make very exciting reading, but some consideration of statistical data is needed to develop a comprehension of the world and U.S. energy situations. Various organizations have collected, tabulated, and graphed a huge volume of every sort of statistical data related to energy. Here, only the data considered essential for understanding the past and present energy story are included.

It is hard to get a feel for large-scale energy production and consumption because the numbers are so large that relating them to familiar experiences is impossible. But we can all relate to a quantity like a BTU. Recall that it is just the energy required to raise the temperature of a pound of water by one degree Fahrenheit. Compare this with U.S. and world energy consumption, which is measured in quadrillions of BTUs. Since large energy considerations often involve quadrillions of BTU, a new unit, the Quad, has been defined. A Quad is 1 quadrillion (10^{15}) BTUs.

One point of reference in considering energy production and consumption is the total energy falling on the earth from the sun every year. This energy input amounts to about 5 million Quads per year. By contrast, human activities result in producing around 500 Quads per year. The man-produced energy is around 1/100 of one percent of the energy flowing from the sun.

A comprehensive source of statistics on past energy production and consumption is the Energy Information Administration (EIA), a branch of the U.S. Department of Energy. EIA publishes an Annual Energy Review and posts it on the web at <http://www.eia.doe.gov/emeu/aer>. The EIA website is a source of a wealth of information on energy production and consump-

tion. It is recommended for readers who want to dig deeper. EIA statistics were used as the main source of statistical information in this chapter.

There are other valuable sources of statistics on energy production and consumption. One of these is the British Petroleum BP Statistical Review of World Energy at <http://www.bp.com/statisticalreview>. This publication appears annually and was used in this chapter for more recent data than is available from EIA. Another useful source is the International Energy Agency (IEA), which publishes a report titled “Key World Energy Statistics” (available at <http://www.iea.org>). It should be noted that the different statistical reviews report slightly different values for the same data because of different data collection and analysis methods. However, the results from different sources generally agree within a few percent, and trends are comparable. Both BP and IEA report energy consumption in Million Tonnes of Oil Equivalent (MTOE). MTOE may be converted to Quads by multiplying by 0.03979. (Note: A tonne is a metric ton or 1,000 kilograms or 2,200 pounds.)

The most recent available data on energy production and consumption (at the time of writing) are presented in this chapter. These data suffice for giving a snapshot picture of energy production and consumption. Readers can find current information at the EIA, BP, or IEA website.

3.2 World Energy Production and Consumption

World energy production and consumption in 2009 was about 488 Quads. 2009 world energy production by source (rounded off) was as shown in Table 3-1.

Figure 3-1 shows historical data for world energy consumption. Figure 3-2 shows the shares of total world energy use for three major energy consumers through 2009. The figure shows the recent history for energy consumption in the U.S. and in China and India, two developing countries that have (or will have) major impacts on world energy consumption. This is one of the

Table 3-1. World Energy Production by Source (2009)

Source	Energy Produced (Quads)	Percentage of Total
Coal/peat	132	27.0
Natural Gas	103	21.1
Oil	162	33.2
Nuclear	28	5.8
Hydroelectric	11	2.2
Other	52	10.7
Total	488	100.0

Data Source: International Energy Agency

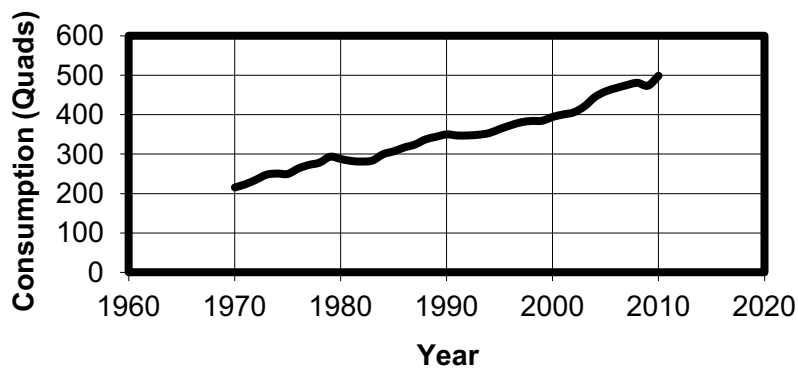

Figure 3-1. World Energy Consumption

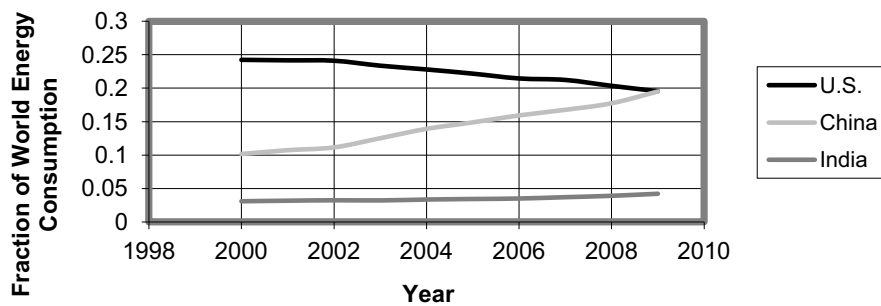

Figure 3-2. Shares of World Energy Consumption

most revealing figures in the book since it shows the shift towards consumption in China, which is now the major driver of increases in world energy demand. China's energy use surpassed U.S. levels in 2009¹. Since China's population was over four times larger than the U.S. population, China's per capita energy consumption in 2009 was about 23 percent of U.S. per capita consumption. China's per capita consumption is expected to grow as development proceeds. India has not yet experienced the rapid growth in energy consumption seen in China, but similar growth is anticipated.

3.3 U.S. Energy Production and Consumption

In the early twenty-first century, the U.S. consumed around 100 Quads of energy per year. This amounts to about 11 kw of power per person in the U.S. (around 38,000 BTU per hour). This power is the sum of power used directly by individuals and power used in all of the business, industry, and government activities that support the human population. The rest of the world uses about 390 Quads per year for a population that is about 20 times the U.S. population, resulting in average power use of about 6,300 BTU per hour (or 1.8 kw per person). Of course, there are great variations in power use in different countries.

In 2009, the U.S. energy consumption by source (rounded off) was as shown in Table 3-2. (The consumption figures include consumption of foreign as well as domestic resources.)

Table 3-2. U.S. Energy Consumption by Source (2009)

Source	Energy Consumed (Quads)	Percentage of Total
Coal	19.6	20.9
Natural Gas	23.4	24.7
Oil and other liquid hydrocarbons	35.3	37.3
Nuclear	8.4	8.9
Hydroelectric	2.7	2.9
Other	5.0	5.3
Total	94.6	

Source: U.S. Energy Information Administration

The “Other” category for U.S. production includes small, but increasing, renewable energy.

Figure 3-3 shows historical U.S. energy consumption. U.S. energy consumption in 2009 by use by sector is shown in Table 3-3 (values rounded). Primary energy is energy consumed to produce delivered energy, the energy remaining after losses in production, and in delivery to the site where the energy is used.

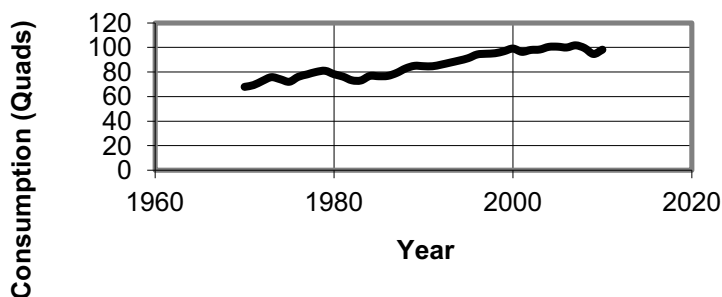

Figure 3-3. U.S. Energy Consumption

Table 3-3. U.S. Primary Energy Consumption by Sector (2009)

Sector	Consumption (Quads)	Percentage of Total
Residential	21	22
Commercial	18	19
Industrial	28	30
Transportation	27	29
Total	94	

Source: U.S. Energy Information Administration

2009 U.S. domestic energy production by source is shown in Table 3-4.

Table 3-4. U.S. Domestic Energy Production by Source (2009)

Source	Production (Quads)	Percentage
Coal	22	30
Natural Gas	22	30
Crude Oil	11	15
Nuclear	8	11
Hydroelectric	3	4
Natural Gas Plant Liquids	2	3
Other	4	5
Total	73	

Source: U.S. Energy Information Administration. Note: Production values and percentage values are rounded, causing a small difference between totals reported and the sum of individual entries. The total production reported is correct.

In 2009, the U.S. imported around 30 Quads of energy and exported 7 Quads.

Figure 3-4 shows the 2009 U.S. energy flows in a very useful and comprehensive format. The Lawrence Livermore National Laboratory prepares such diagrams annually².

3.4 Oil Production and Consumption

Because oil is crucial to the transportation sector, and because the U.S. depends heavily on oil imports, data on oil production and consumption are addressed separately.

The U.S. consumed 19 million barrels of oil per day in 2009. (A barrel of oil is 42 U.S. gallons.) U.S. production provided about 7.2 million barrels per

Estimated U.S. Energy Use in 2009: ~94.6 Quads

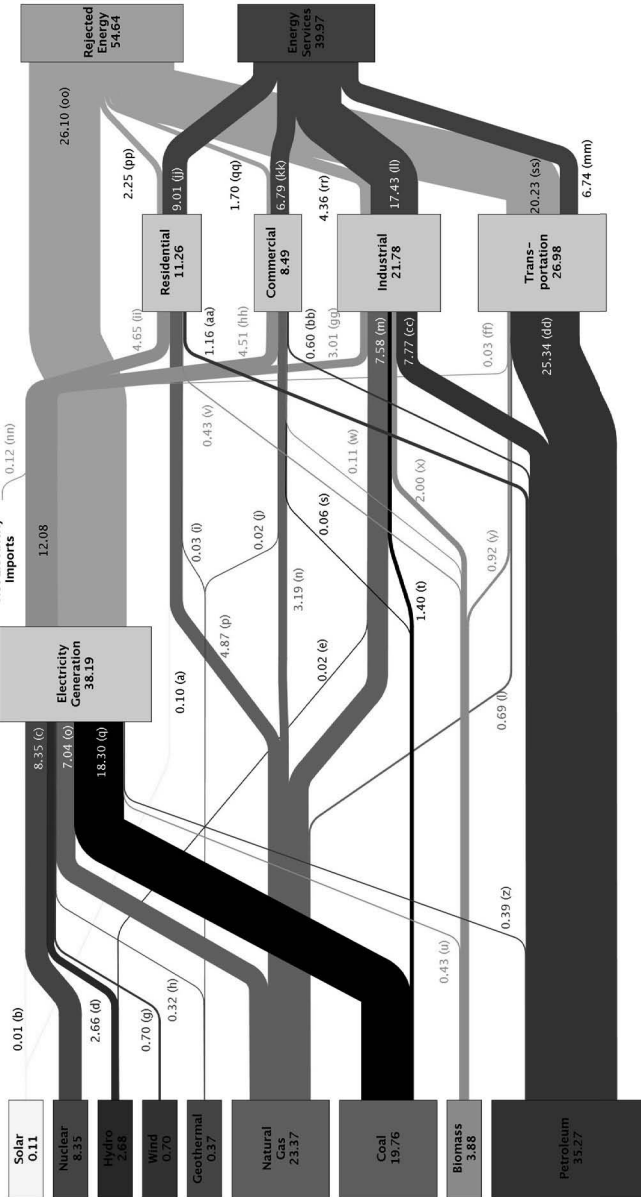

Source: LLNL, 2010. Data is based on DOE/EIA-0384(2009), August, 2010. If this information or a reproduction of it is used, credit must be given to the Lawrence Livermore National Laboratory and the Department of Energy, under whose auspices the work was performed. Distributed electricity represents only retail electricity sales and does not include self-generation. EIA reports flows for non-thermal resources (i.e., hydro, wind and solar) in BTU-equivalent values by assuming a typical fossil fuel plant "heat rate." The efficiency of electricity production is calculated as the ratio of the energy in the electricity to the energy in the fuel. The efficiency of electricity production is calculated as the ratio of the energy in the electricity to the energy in the fuel. The efficiency of electricity production is calculated as the ratio of the energy in the electricity to the energy in the fuel. Totals may not equal sum of components due to independent rounding. LLNL-MI-410527

Figure 3-4. Energy Flows of Lawrence Livermore National Laboratory

day (38 percent), and imports provided 11.7 million barrels per day (62 percent). Historical data on U.S. oil production and consumption are shown in Figure 3-5.

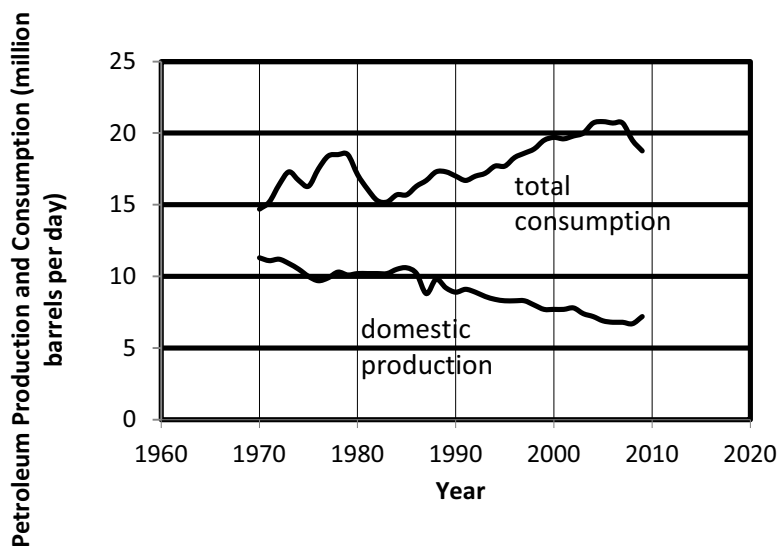

Figure 3-5. U.S. Petroleum Production and Consumption

Most of the imports of oil by the U.S. (75 percent) come from 10 countries. The amount from each foreign supplier is shown in Table 3-5.

Table 3-5. U.S. Oil Imports (2010)

Country	Imports by U.S. (millions of barrels per year)	Percentage of U.S. Imports
Canada	924	22
Mexico	467	11
Saudi Arabia	399	9
Nigeria	374	9
Venezuela	360	8
Russia	222	5
Algeria	185	4
Iraq	151	4
Angola	143	3

Source: U.S. Energy Information Administration

Clearly, this list includes countries with questionable long-term stability and friendliness toward the U.S. The peril of U.S. dependence on foreign oil is obvious.

Importing 11.7 million barrels per day (2010 rate) at a price of \$100 per barrel (spring 2010 price) costs about \$1.2 billion per day (\$438 billion per year). Analysts expect oil prices to fluctuate, but with a continual upward trend. The point to remember is prices will vary, but the cost of imported oil is in the range of \$1 billion per day.

Domestic and imported crude oil is processed to provide desired products. Most crude oil is used to produce gasoline. The breakdown of products produced from oil is as shown in Table 3-6.

Table 3-6. Products Produced from Oil

Product	Percentage
Gasoline	46
Distillate Fuel Oil	21
Jet Fuel	9
Coke	5
Still Gas	4
Residual Fuel Oil	4
Liquefied Gas	4
Asphalt and Road Oil	3
Other	4

Source: U.S. Energy Information Administration

Almost all the oil being used in the early twenty-first century is crude oil that is extracted from the earth in liquid form. Additional resources exist in the form of oil sands and oil shale. These resources are hydrocarbons that must be mined and processed to provide liquid hydrocarbons that are similar to crude oil (see Sections 4.3 and 4.4).

3.5 Natural Gas Production and Consumption

Natural gas is a fossil fuel composed mostly of methane (typically around 90 percent) and smaller amounts of ethane, butane, and propane. The heavier gases (butane and propane) are separated from the methane and ethane. The higher boiling points of the heavier gases (-28°F and -11°F for isomers of butane and -47°F for propane) make it possible to liquefy them with modest pressurization. Liquefaction increases the density of the gases and facilitates their delivery for use as a fuel. Butane lighters and propane-fueled grills are commonplace.

The methane and ethane in natural gas provide a convenient fuel for residential, commercial, and industrial applications. Natural gas use for electric power generation is increasing because of cost and environmental advantages. The chemical industry uses large quantities of natural gas as a feedstock for producing various chemicals. There is also minor use as a transportation fuel, and this type of use is increasing.

Natural gas reserves are said to be conventional or unconventional. In extracting conventional gas, it is only necessary to drill into gas-bearing underground formations. The reduced pressure at the well bore causes flow from the higher-pressure gas formation. The extraction of unconventional gas requires modification of underground conditions (specifically, fracturing gas-bearing rock to provide flow passages for the gas). Unconventional gas already contributes significantly to U.S. production, and many analysts³ are confident that great quantities of unconventional gas can be extracted economically.

Natural gas reserves are said to be “proved reserves” if it is reasonably certain that gas can be extracted competitively under existing economic and operating conditions. Proved reserves include conventional gas and economically recoverable unconventional gas.

Some natural gas reserves occur in small pockets that are far from existing pipelines. This is called “stranded gas.” It is currently uneconomical to exploit much of the stranded gas.

Methane is also produced continuously and naturally by the anaerobic digestion of dead plant and animal matter. Thus, methane may be viewed also as a renewable energy resource (see Chapter 7).

Natural gas quantities are measured in cubic feet evaluated at standard temperature and pressure (a temperature of 60°F and one atmosphere of pressure). The energy content of natural gas is about 850 to 1050 BTU per cubic foot (low heating value or LHV) and 950 to 1150 BTU per cubic foot (high heating value or HHV).

Figure 3-6 shows U.S. natural gas production and consumption. The 2008 U.S. consumption of natural gas was around 23 trillion cubic feet. The U.S. produced about 82 percent of the natural gas that it consumed in 2008. The balance was imported. Hydrofracturing has since enabled large increases in U.S. natural gas production. The U.S. is poised to become an exporter of gas.

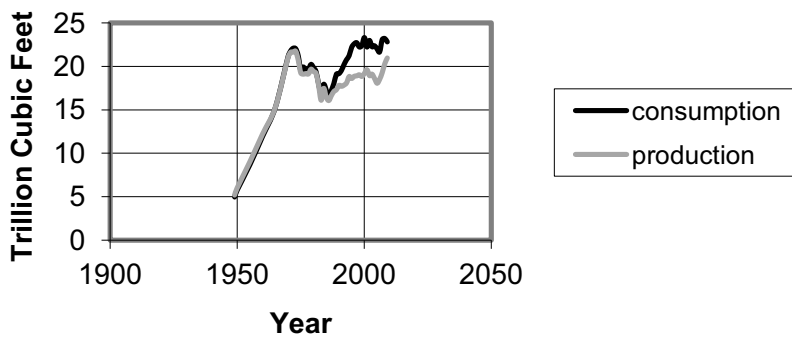

Figure 3-6. U.S. Natural Gas Production and Consumption

The end uses of natural gas are as shown in Table 3-7.

Table 3-7. U.S. Natural Gas Uses

Use	Percentage of Total Use
Industrial (excluding electric power)	30
Residential	20
Electric Power	29
Commercial	13
Oil & Gas Industry Operations	5
Pipeline Fuel	3
Transportation	0.1

Source: U.S. Energy Information Administration

World annual consumption is around 110 trillion cubic feet (2008).

Proved reserves of natural gas in the U.S. are estimated to be 284 trillion cubic feet (2011). The reserves estimate has been increasing every year in recent years because of the addition of unconventional (but proved) gas. The U.S. share of proved world natural gas reserves is around 3 percent. Estimated proved world reserves are around 6,100 trillion cubic feet, with almost 60 percent occurring in OPEC countries. Of course, new hydrofracturing extraction technology for unconventional gas provides access to much more economically recoverable gas (up to 10 times as much as current proved reserve estimates). However, as we shall see in Chapter 4, there are environmental issues related to hydrofracturing. It remains to be seen whether these issues will limit the use of hydrofracturing technology to extract natural gas.

3.6 Coal Production and Consumption

The U.S. consumes about 1.1 billion tons of coal per year (2010). This was around 15 percent of world coal consumption. (Note: Coal consumption in China was double the U.S. consumption in 2010.) Over 90 percent of U.S.

coal consumption is in electric power plants. Figure 3-7 shows U.S. coal production. Essentially all U.S. coal is produced domestically.

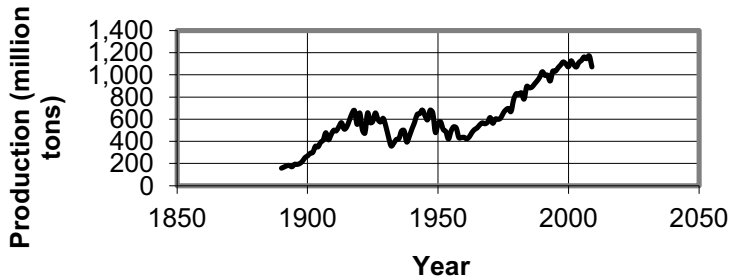

Figure 3-7. U.S. Coal Production

The estimated recoverable coal reserves in the U.S. total about 264 billion tons. There is much more coal in the ground than 264 billion tons, but not all of it is economically or technically recoverable.

The estimated world recoverable coal reserve is about 1 trillion tons.

Coal combustion yields about 20 million BTU per ton. Therefore the energy in the recoverable coal reserves is about 5400 Quads for the U.S. and about 20,000 Quads for the world.

Clearly, coal is a huge energy resource, but its use has environmental consequences. Pollution and climate change concerns may prevent full exploitation of the coal resource. See Chapter 4 for details.

3.7 Uranium Production and Consumption

Uranium occurs in low concentrations, even in the richest ores. However, since the amount of energy available from each pound of uranium is very large, high mining and refining costs are tolerable. The ore cost in a modern nuclear power plant currently contributes only about five percent to the total cost of producing electricity.

The size of the recoverable uranium resource depends on the cost of the ore. 2010 ore costs were about \$130 per kilogram. Estimated U.S. reserves available at \$130 per kilogram are 200,000 metric tons, and estimated world reserves are around 5.3 million metric tons. Much larger uranium reserves are available at higher cost, and using higher cost ores would have a small impact on nuclear power costs.

Current reactor designs (mostly light water reactors) require around 200 metric tons of uranium ore per year to fuel a 1000 MWe (megawatts electric) reactor that operates at full power 90 percent of the time. This translates into about 7,400 metric tons per Quad of electrical energy or 2,500 metric tons per Quad of thermal energy per year.

Current reactor designs can produce around 80 Quads of thermal energy with the estimated U.S. low-cost reserves of 200,000 metric tons of uranium ore. Advanced reactors, especially breeder reactors, require less fuel per unit of energy produced.

Extracting the energy from uranium ore requires the construction of nuclear power reactors. A power reactor with a rating of 1000 megawatts electric that operates 90 percent of the time produces about 0.08 Quads of thermal energy per year (0.027 Quads of electrical energy). Twelve large (1000 MWe) reactors would be needed to provide one Quad of thermal energy per year.

3.8 Electricity

Evaluation of the consumption of electrical energy requires special consideration. The U.S. produces about 90 percent of its electricity in thermal plants, that is, plants that use fossil fuel combustion or nuclear fission to produce heat and make steam that drives a turbine-generator, or natural gas that drives a gas turbine-generator. Fuels consumed in 2009 to produce electricity in thermal plants are coal (18.3 Quads), natural gas (7.3 Quads), petroleum (0.4 Quads), and nuclear (8.3 Quads). The remainder is hydroelectricity and electricity from other renewables.

Production of electricity in thermal plants unavoidably results in the production of waste heat. Only 35 to 40 percent of the energy released in a coal or nuclear thermal plant can be captured as electricity. (Somewhat higher efficiencies can be achieved in dual cycle natural gas powered plants, plants that use hot exhaust gases to produce steam that drives a second turbine.) The remainder of the energy is lost to the environment as heat. Further electrical losses of 5 to 10 percent occur during transmission and distribution. About 30 percent of the total energy that was consumed to make electricity in thermal plants is delivered to the end user as electrical energy.

Electricity is a significant part of current energy use in all sectors except transportation. In order to account for all energy consumed, consumption figures are based on the energy used to produce, transmit, and distribute electricity rather than actual electrical energy consumed by the end user. The annual U.S. consumption of energy to produce electricity is about 39 Quads, and consumption of delivered electrical energy is about 13.5 Quads: 9.3 Quads from fossil plants, 2.7 from nuclear plants, 0.9 Quads from hydroelectric plants and 0.5 Quads from other renewable sources.

3.9 Greenhouse Gas Release and Pollution from Energy Production

(All data reported in this section were obtained from Reference 4.)

The consumption of fossil fuels results in the release of greenhouse gases and pollution. Carbon dioxide is the principal anthropogenic greenhouse gas. The percentage of total releases of carbon dioxide attributable to each energy sector is shown in Table 3-8.

The main pollutants related to fossil fuel energy production are carbon monoxide, oxides of nitrogen, volatile organic compounds, particulate matter, sulfur dioxide, and ammonia.

Table 3-8. Carbon Dioxide Emissions (2009 data)

Energy Sector	Percentage of Energy-Related CO ₂ Release
Residential	21.4
Commercial	18.8
Industrial	25.6
Transportation	34.2

Source: U.S. Energy Information Administration

The estimates of the release of carbon dioxide into the atmosphere by anthropogenic causes ranges from about 6.4 billion tonnes of carbon contained in 23.5 billion tonnes of carbon dioxide to about 7.2 billion tonnes of carbon contained in 26.4 billion tonnes of carbon dioxide per year. The issue relative to climate change is:

How significant are the effects due to anthropogenic causes as compared to natural effects due to natural causes?

This issue will be addressed in more detail in Chapter 19, but it is useful to examine the pertinent facts here. Anthropogenic carbon dioxide enters the atmosphere then distributes between the three natural reservoirs: the atmosphere, the oceans, and the terrestrial sinks (plants and soil). The annual anthropogenic emissions are small compared to the total carbon contained in the natural sinks (730 billion tons in the atmosphere, 2,000 billion tons in terrestrial sinks, and 38,000 billion tons in the oceans)⁴. However, the carbon dioxide accumulates in the atmosphere over time and can grow to levels that are significant compared to natural levels.

3.10 Energy Recoverable from Non-Renewable Resources

Fossil and nuclear energy reserve estimates are summarized in Table 3-9. Total estimated remaining reserves and estimated recoverable reserves are presented. These estimates are subject to various uncertainties. Total reserves are based on analysis of geology and past production histories by experts. Information for U.S. reserves is generally more reliable than esti-

mates in some other countries. Some countries lack the expertise to make good estimates, and some may falsify estimates for economic or political purposes. Recoverable reserves are less than remaining reserves because of technical, environmental, safety, and economic constraints. Estimates of recoverable reserves are especially sensitive to the cost of extracting and processing the resource. Low-grade deposits may contain large quantities of a resource that are uneconomical to extract. Of course, scarcity could make it practical to extract previously uneconomical resources.

Table 3-9. Non-Renewable Energy Resources

Non-Renewable Resource	Reserve Quantity		Energy Content (Quads of Thermal Energy)	
	WORLD	U.S.	WORLD	U.S.
COAL (billion tons) ^c	1,000	270	20,000	5,400
OIL (billion barrels) ^o	1,000 to 2,000	20 ^v	6000-12,000	120
NATURAL GAS ^{ng} (trillion cubic feet of proved reserves)	6,200	200	6,200	200
NATURAL GAS ^{ung} (trillion cubic feet of gas if unconventional reserves are exploited fully) ^t	?	1,800 to 2,000	?	1,800 to 2,000
OIL SHALE (billion barrels) ^s	3,000	2,000	60,000	40,000
OIL SANDS (billion barrels)	3,000	2	60,000	40
URANIUM (million tonnes) ^u (at \$130/ kilogram or less and current reactor designs)	5.3	0.2	2120	80

c: Average coal energy content: 20 million BTU per ton. Energy Information Administration <http://www.eia.doe.gov/oiaf/ieo/coal.html>

o: Energy Information Administration provides the U.S. reserve estimate. <http://www.eia.doe.gov/neic/quickfacts/quickoil/html>

s: U.S. Energy Information Administration <http://www.eia.doe.gov>

t: Recovering indicated quantities depends on determining that hydrofracturing has acceptable environmental impact

ng: Energy Information Administration website <http://www.eia.doe.gov>

ung: Unconventional natural gas reserves are unproved, but many analysts believe that this resource is economically recoverable.

u: Based on an estimated 200 tonnes per year for a 1000 MWe reactor.

v: It should be noted that application of hydrofracturing is providing access to new oil recoverable reserves. The size of the increase over the reported 20 billion barrels is still unknown.

3.11 Interpretation

Statistics are of little value until someone analyzes them and transforms raw information into useful knowledge. The result of this analysis depends on the capability and bias of the analyst. The reader may choose to perform his/her own analysis, but some conclusions that appear to be suggested by the data are presented below with the acknowledgment that they were filtered by the author's capability and bias.

The statistics relate to two issues: energy availability and environmental effects.

The most striking availability statistic is the reliance of the U.S. on imported oil. U.S. oil production peaked years ago, and remaining reserves are far less than needed to satisfy current and anticipated demands. The expense of purchasing oil from other countries is enormous and a cause for concern. In addition to the cost, one must worry about the continued availability of foreign supplies. There is no assurance that these countries will be able or willing to satisfy America's thirst for oil. Oil sands and oil shale contain huge quantities of hydrocarbons that can be converted into a substitute for crude oil, but cost and environmental impact are limiting factors in using these resources.

Proved U.S. reserves of natural gas will satisfy domestic needs for only about a decade, but there is a huge unconventional resource that could increase supply enough to satisfy consumption at the current rate for around a century if, as expected by many analysts, this resource is exploited fully. However, there are still unresolved environmental issues that may limit the production of unconventional gas.

Coal and uranium can supply large quantities of energy from domestic resources, but both face implementation hurdles. For coal, the main issue is environmental impact. For nuclear, the main issue is safety.

Carbon dioxide releases from fossil fuel use are significant compared to the inventory of atmospheric carbon dioxide and to the natural exchanges

between earth, sea, and air. As we shall see in Chapter 19, there is strong evidence that the use of fossil fuels creates undesirable environmental effects, especially global warming. The U.S. gets around 85 percent of its energy from fossil fuels. If America decides global warming concerns require a reduction in fossil fuel use, a huge transition will be required. The same can be said of fossil fuel use in other countries.

The environmental effects of hydrocarbon combustion in transportation are important (especially in urban areas where vehicle use is concentrated), but these emissions represent less than one third of total carbon dioxide emissions. Producing electricity depends heavily on coal and, to an increasing level, natural gas. Both of these fuels release carbon dioxide when burned, and coal use also releases significant quantities of pollutants. Reducing atmospheric contamination from carbon dioxide and pollutants will require changes in energy production and energy use. Options for change are outlined in subsequent chapters.

References

1. British Petroleum Report “BP Statistical Review of World Energy June 2011” available at <http://www.bp.com/statisticalreview>.
2. Lawrence Livermore National Laboratory website, available at <http://www.llnl.gov>.
3. Natural Gas Supply Association website, available at <http://www.naturalgas.org>.
4. Energy Information Administration Report, “Greenhouse Gases, Climate Change and Energy,” November 2003, <http://www.eia.doe.gov/1605/ggcebro/chapter1.html>.

Exercises

- 3-1. World energy consumption in 2007 was 475 Quads. Use the Internet to find the world energy consumption last year. Discuss plausible causes for the new energy use level.
- 3-2. Repeat Problem 3.1 for U.S. consumption.

- 3-3. What was world energy consumption in Exajoules in 2007?
- 3-4. Use the Internet to discover recent energy use levels in China and India. Discuss the results.
- 3-5. Use the Internet to find information on recent trends in solar, wind, and geothermal energy production in the U.S. Discuss your findings.
- 3-6. Use the Internet to find the current price of oil and the current daily consumption of imported oil in the U.S. How much does the U.S. currently spend per day for imported oil?
- 3-7. Use the Internet to find current energy production with natural gas in the U.S.
- 3-8. How much carbon dioxide (tons) is produced by coal combustion in the U.S. by burning 1.1 billion tons? Assume coal is pure carbon. (Note that carbon dioxide is CO_2 . Since carbon has an atomic weight of 12, and oxygen has an atomic weight of 16, CO_2 is 27.3 percent carbon by weight.)
- 3-9. Hydrofracturing (or fracking) is widely used in the U.S for extracting natural gas. Use the Internet to discover the current production of shale gas by fracking in the U.S. In 2011, the French government banned the use of hydrofracturing in France. Why do you think the French made this decision?
- 3-10. How many U.S. jobs could be created by the money saved if the U.S. cut its oil consumption in half by increasing vehicle efficiency and switching to renewable and electrical energy? Assume each job requires \$100,000 for salaries, benefits, and overhead.

Part II: **ENERGY SOURCES**



4

Fossil Fuels

The Main Points

- The fossil fuel resources are oil, oil shale, oil sands, natural gas, and coal.
- Fossil fuels consist of carbon and hydrocarbons (compounds composed entirely of carbon and hydrogen).
- Producing energy with fossil fuels releases carbon dioxide, a greenhouse gas.
- Light hydrocarbons (four carbon atoms per molecule or less) are gaseous at normal temperature and pressure. Heavier hydrocarbons are liquid or solid.
- Oil is used in transportation, as a chemical feedstock, and for heating.
- Natural gas is used for heating, as a chemical feedstock, for producing electricity, and as minor contributor to transportation energy.
- Coal is used for producing electricity and in steelmaking.
- U.S. oil production peaked around 1970.
- Many analysts provide estimates of future world oil availability. Hubbert's method is best known. Most predictions estimate a peak in world oil production anywhere from 2010 to 2040.
- Accessible natural gas reserves and production rate have increased significantly because of new acquisition technology called hydrofracturing (or fracking).

- **Fracking is beginning to have an impact on accessible oil reserves and production rate. Previously inaccessible oil is now being extracted.**

4.1 Introduction

Fossil fuels are the result of the action of heat and pressure on dead plant and animal matter buried in the earth. The dead matter was initially composed mostly of carbon, hydrogen, and oxygen. Over millions of years, heat and pressure beneath the surface induced chemical reactions that eliminated the oxygen and resulted in carbon and hydrocarbons. Coal is a solid fossil fuel composed mostly of carbon.

Hydrocarbons found in the earth have a wide range of chemical compositions. Some hydrocarbons are gases, some are liquids, and some are solids at ordinary temperatures and pressures. The fossil fuel resources are oil, natural gas, coal, oil sands, and oil shale. Additional fuels are available as biomass and various fuels derived from biomass. Biofuels are discussed in Chapter 7.

Fossil fuels enabled the Industrial Revolution (approximately 1820-1870 in the United States), and their continued use enables the current high standard of living in developed countries. Fossil fuels are a finite resource that will be depleted someday, but huge reserves remain that could sustain civilization for at least a few more decades. However, environmental concerns may prevent using them to their full capacity. There is little doubt that fossil fuel acquisition and transport result in environmental, health, and safety issues, and that fossil fuel consumption impacts climate and the environment (see Chapter 19). If the problems related to fossil fuel acquisition, transport, and use grow as predicted by many analysts, it may be necessary to curtail their use even if they remain available.

Fossil fuels may be used directly to produce energy through combustion, or they may be chemically altered prior to their use as a fuel. The most widely useful form of fuel is liquid, followed by gas, and then solid. Chemical con-

version of fossil fuels includes liquid-to-liquid, solid-to-liquid, solid-to-gas, and gas-to-liquid processes. These conversions involve adding, subtracting, and/or rearranging atoms in the molecules of the source material.

Hydrocarbons are compounds comprised entirely of hydrogen and carbon. The simplest hydrocarbon is methane, CH₄. Methane, ethane, propane, butane, and isobutane are gases at ordinary temperatures and pressures (defined as conditions at or near usual ambient conditions). Hydrocarbons with larger molecules (more than four carbon atoms per molecule) are liquids or amorphous solids at ordinary temperatures and pressures.

Hydrocarbons exist in an enormous range of chemical species. Their chemistry depends on the number of carbon atoms per molecule, the number of hydrogen atoms per molecule, and the configuration of the molecule. Molecule shapes may be linear, branched, or ring-shaped. Even for a limited range of carbon atoms per molecule, many different hydrocarbon species are possible.

Hydrocarbons that are gaseous at room temperature and atmospheric pressure have the fewest carbon atoms and the largest ratios of hydrogen atoms to carbon atoms. The properties of the important gaseous hydrocarbons are shown in Table 4-1.

Table 4-1. Properties of Gaseous Hydrocarbons

Hydrocarbon	Formula	H/C Ratio	Boiling Point (at atmospheric pressure)
Methane	CH ₄	4:1	-258.5°F (-161.4°C)
Ethane	C ₂ H ₆	3:1	-127.5°F (-88.6°C)
Propane	C ₃ H ₈	2.67:1	-43.8°F (-42.1°C)
Butane	C ₄ H ₁₀	2.5:1	16°F (-0.5°C) for n-butane
			11.1°F (-11.6°C) for isobutane

Note: Butane has two isomers—compounds with the same chemical formula but different molecular structures and different properties.

All of the gaseous hydrocarbons listed in Table 4-1 can be liquefied at lower temperatures and/or higher pressures. The boiling point data show the boiling temperature increases as the number of carbon atoms per molecule increases. Hydrocarbons with more than four carbon atoms per molecule are liquid or solid at ambient temperatures.

Liquid hydrocarbons used for fuel have hydrogen-to-carbon ratios of 1.7 to 2.2. It is important to remember that a hydrogen-to-carbon ratio of around two is needed for liquid hydrocarbon fuels. Carbon atoms per molecule range from five to 17 for gasoline, kerosene, jet fuel, and Diesel fuel and up to 45 for heavy fuel oil.

Coal is a complex mixture of carbon and hydrocarbon compounds with a hydrogen-to-carbon ratio of about 0.8.

Processing organic chemicals to modify properties involves changing the number of carbon atoms per molecule and the hydrogen-to-carbon ratio. Oil refining, gas-to-liquid, coal-to-liquid, coal-to-gas, biomass-to-liquid, and biomass-to-gas processing all depend on such processes.

Liquid and gaseous hydrocarbons all have high heating values (HHV) of around 20,000 BTU per pound. Volumetric high heating values (such as BTU per cubic foot or BTU per gallon) vary widely because of density differences.

4.2 Oil

Oil is a mixture of liquid hydrocarbons. Oil properties depend on the relative amounts of the constituent hydrocarbons. Oil hydrocarbons with a preponderance of smaller molecules (fewer carbon and hydrogen atoms per molecule) are said to be light oils, and those with a preponderance of larger molecules are said to be heavy oils. Light oils are generally less viscous and have lower boiling points than heavy oils.

4.2.1 Importance of Oil

Oil plays a crucial role in modern civilization because of three factors:

1. Oil is a highly concentrated source of energy (around 20,000 BTU per pound).
2. Oil is readily transportable to where it is needed.
3. Oil is available in huge quantities worldwide at reasonable cost (at least for the present).

Because of these factors, oil supplies almost all of the world's energy for transportation. It is also heavily used for space heating and as a feedstock for many of the chemicals used in modern society. Without oil or a suitable substitute, modern civilization would crumble.

4.2.2 Origin of Oil

There are two theories about the origin of oil.

In the biogenic theory¹, dead matter, primarily dead microscopic aquatic animals, was buried long ago beneath the earth by accumulating sediment. The heat and pressure deep underground caused the transformation of the remains of the living matter into oil, some of which was trapped beneath impervious layers. The oil used by humans is the result of finding and tapping these reservoirs of underground oil.

In the abiogenic theory², carbon located deep in the earth undergoes chemical processes (and maybe biological processes involving microbes), and the result is oil. According to the abiogenic theory, oil is being produced continuously and is migrating toward the surface of the earth. The abiogenic theory discounts the role of dead organisms in oil production and refutes the conventional assumptions about formation, location, and amount of oil available for future exploitation.

The controversy about the origin of oil is scientifically interesting, but it has little practical relevance unless its resolution can help us find oil in previously ignored places or can demonstrate that oil is being replenished in accessible areas of the earth at a fast enough rate to replace the oil removed.

In this book, the biogenic vs. abiogenic controversy will be assumed to be irrelevant in considerations of energy issues facing America and the world in the twenty-first century. Pressing issues in the early twenty-first century do not allow the luxury of reliance on salvation by abiogenic oil. Maybe the abiogenic theory proponents and/or powerful new drilling technology will eventually lead oil exploration to new and productive discoveries of vast oil reservoirs, but relying on this serendipity is unwise.

4.2.3 Acquiring Oil

Oil acquisition activities include exploration, drilling, and extraction.

Exploration involves characterization of subsurface conditions in order to identify regions with the potential of yielding oil. The main tool used for finding oil is seismic testing. A shockwave is generated above the region being investigated. On land, special trucks use heavy mechanisms to impact the surface. Offshore seismic testing relies on pressure disturbances generated underwater with compressed air devices. In both cases, an array of sensors monitors the reflected sound waves, and computer analysis provides a sort of three-dimensional map of subsurface conditions. Geologists use this information to identify promising sites for subsequent drilling.

Drilling involves use of a rotating bit on the end of a shaft that is lengthened as drilling progresses. The average depth of oil and gas wells is about one mile. The deepest wells are about five miles deep. Well shafts can be vertical or slanted and can even be turned to the horizontal far below the surface. Slanted and horizontal drilling techniques enable the creation of multiple holes at one drilling site (as shown in Figure 4-1). This is very important for expensive off-shore sites. Also, since oil strata may exist in horizontal deposits beneath impervious rock, horizontal wells expose more well surface to the deposit and enhance oil flow to the surface.

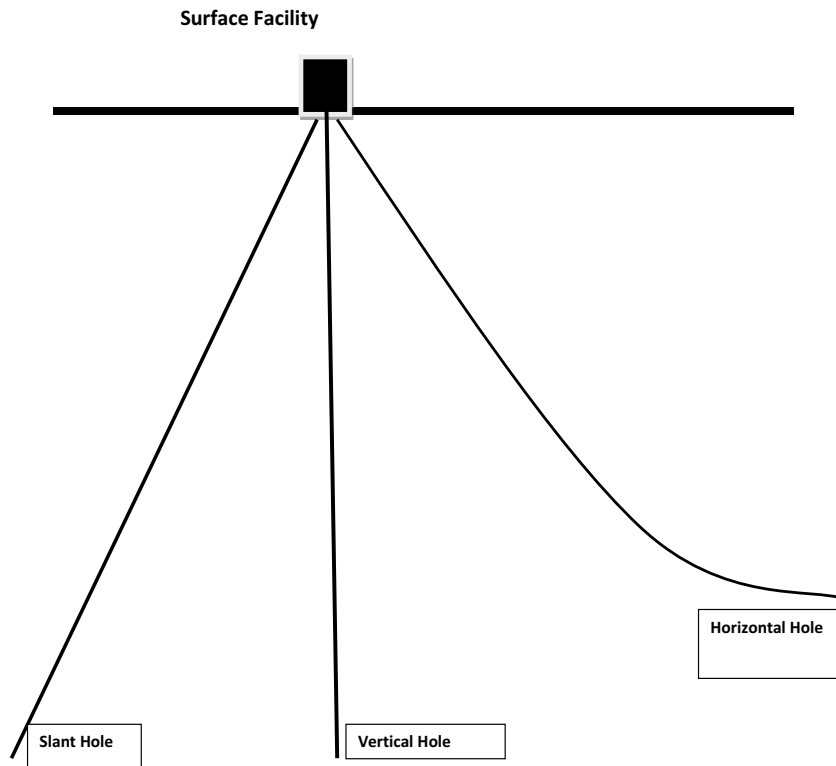

Figure 4-1. An Oil Well

A well is drilled through the region lying above the deep, oil-bearing formation. The well passes through any aquifers in the well's path, requiring a leak-tight casing to prevent water contamination.

Huge platforms, either resting on legs that sit on the sea floor or floating, provide sites for offshore drilling. Platforms that rest on legs are suitable for shallower sites. Floating platforms, essentially large barges that are held stationary by thrusters in the water, are needed for deep water applications. These platforms house all of the equipment used in drilling and facilities for large work crews. Because of the expense of building and operating an offshore facility, they are generally used to drill 30 or more holes.

When a well contacts an oil-bearing region, it provides a site with lower pressure than exists in the surrounding earth. The pressure difference is

often great enough to force oil and/or gas to the surface. Early oil wells sometimes experienced a “gusher,” in which oil spurted high into the air. Modern well technology can prevent this uncontrolled flow.

Eventually, the flow of oil and gas out of a reservoir causes the pressure to drop. Further removal requires pumping, repressurization with injected gas or solvent extraction. Even with pumping, much of the oil remains trapped in the reservoir. This oil exists as small drops embedded in rock formations. Sometimes it is feasible and practical to inject fluids that free some of this trapped oil. These techniques are called secondary or tertiary extraction methods. Gas, usually carbon dioxide or natural gas, can be pumped into a nearby well to increase the underground pressure and release the oil. Steam may also be injected to reduce the viscosity of the oil and enable it to flow. Detergent solutions may be used to free the oil. Even downhole microwave heaters have been developed to heat trapped oil and enable it to flow.

Hydrofracturing, or fracking, may be used to acquire oil that is tightly bound in underground rock formations. Hydrofracturing involves high-pressure injection of a mixture of water, sand, and chemicals (usually of proprietary composition, but generally including toxic components) to fracture the underground formation around the well shaft and create flow paths to release the oil. The sand is a proppant, a material included to keep pathways open once they are created. The chemicals are included to increase pathway formation.

Generally, hydrofracturing involves injecting several million gallons of water under high pressure. After hydrofracturing is complete, pressurization ceases, and oil flows to the well bore and then to the surface. Much of the injected water and associated chemicals return to the surface along with the oil during extraction, and must be disposed of or used in other, subsequent hydrofracturing operations. This is called backflow water.

The impact on previously undisturbed environments and the possible release of harmful chemicals into the air or water has stimulated opposition to hydrofracturing. There is also some concern that alteration of underground rock formations will cause seismic activity.

Hydrofracturing is providing access to new, previously inaccessible oil. For example, the Bakken formation in North Dakota, Montana, and Saskatchewan has become a major producer because of hydrofracturing technology. Hydrofracturing technology certainly increases the reserves of accessible oil in the U.S. and the world, but the magnitude of this resource is still uncertain.

4.2.4 Oil Properties

Oil extracted at various sites varies in properties. It varies in color from black to brown, and even to yellowish or greenish, and it may include impurities such as sulfur. The smaller molecules are lighter and less viscous, and the larger molecules are heavier and more viscous.

4.2.5 Derivatives of Oil

Oil in the as-found state has limited usefulness. However, oil can be processed in refineries to yield a wide array of useful products³. The processes are designed for two main purposes: separation of desired components from undesired components and modification of undesired components to yield desired components.

Distillation is the principal separation process. Distillation occurs in a heated column designed to cause repeated evaporations and condensations of the input material. Components with lower boiling points are extracted at the top of the column, higher boiling point components are extracted at the bottom, and components with intermediate boiling points are extracted at intermediate points along the column.

Modification of oil components generally involves rearranging the atoms in the hydrocarbons that make up the oil. Cracking is the conversion of large hydrocarbon molecules into smaller molecules using heat and/or catalysts. Some of these smaller molecules are desired end products, and some are processed further to yield other desired compounds.

Refinery processes also include chemical reactions to alter the hydrogen-to-carbon ratio in the oil. Hydrogen (produced from natural gas as described in Section 4.7) is reacted with oil at elevated temperature and pressure and in the presence of a catalyst. The objective of this process, called catalytic hydrogenation, is to obtain a hydrogen-to-carbon ratio of around two as needed for liquid fuels.

The characteristics of the extracted oil have a large influence on the processing used to derive desired products. The most important characteristics are the relative amounts of light and heavy components and the concentrations of impurities, mainly sulfur. Low sulfur oil, called sweet oil, is strongly preferred over high sulfur oil, called sour oil.

In modern U.S. oil refineries, about half of the oil is converted into gasoline. The distribution of product yields can change with changing product demands and crude oil properties, but typical products from crude oil are shown in Table 3-6 of the previous chapter.

Liquid hydrocarbon fuels contain a mixture of many organic compounds. Suitability for the various uses as a fuel depends on the specific mix of compounds included. All liquid hydrocarbon fuels have approximately two hydrogen atoms per carbon atom. The number of carbon atoms (and the associated hydrogen atoms) in a molecule determine its suitability for different applications. Gasoline has five to 12 carbon atoms per molecule; kerosene and jet fuel have 11 to 13; diesel fuel and fuel oil have 13 to 17; and heavy fuel oil has up to 45.

No new refineries have been built in the U.S. since the mid-1970s. This fact is primarily due to environmental concerns and siting problems due to community opposition. The increased production needed to satisfy demand has been met by increasing the capacity of existing refineries and by importing finished products produced in refineries located outside of the U.S.

4.2.6 Oil Production, Reserves, and Forecasts

The 2007 world annual production of oil was about 26 billion barrels, and U.S. domestic production was about 2 billion barrels. The U.S. augmented 2007 domestic production with over 3 billion barrels of imported oil and oil products. U.S. production peaked around 1970. Figure 3-4 in the previous chapter shows histories of world and U.S. production. By 2007, cumulative production was about 1 trillion (1,000 billion) barrels for the world and 200 billion barrels for the U.S.

The only rational assumption is oil is a finite resource that is steadily being used up. There is no doubt that decreasing reserves will eventually slow production. Oil shortages are likely in years or decades, not centuries. Since the time required to develop and implement alternative fuels is long, action is needed now, whether the main beneficiaries will be us, our children, or our grandchildren.

Of course, estimating future oil production depends strongly on assumptions about the amount of oil in the earth that is available for recovery. This is the issue of oil reserve estimation. It is not a simple matter. “Experts” have been estimating oil reserves for decades, and most have been seriously wrong. Some forecasts predicted that oil would already be completely used up.

It is important to distinguish between “total reserves” and “remaining reserves.” Total reserves are the recoverable reserves that were in the ground before extraction began, and remaining reserves are reserves still available for extraction. For the U.S., it is estimated about 230 billion barrels of recoverable oil were in the ground initially, and about 200 billion barrels have been extracted. The numbers for the rate of U.S. oil consumption are important in assessing the importance of any future oil discoveries. For example, how important would a new billion-barrel U.S. oil discovery be? One billion barrels sounds like a lot, but it would provide only 10 weeks of U.S. consumption at the current rate of use.

As indicated in Chapter 3, reserve estimates in some countries are less reliable than estimates for U.S. reserves. Nevertheless, analysts attempt to derive meaningful world oil reserve estimates. Most of these estimates say the remaining world reserves of recoverable oil lie between 1 and 2 trillion barrels. Since cumulative world production is around 1 trillion barrels, it appears that one-third to one-half of the recoverable oil that was in the ground initially has been extracted.

We must ask the question, “How long can the world satisfy oil production demands with the remaining resource?” The fact that 1 trillion barrels of oil were consumed in the last hundred years does not suggest that the remaining 1 to 2 trillion barrels will satisfy demand nearly as long, given current demand and expected increases in future demand.

We must turn to the uncertain art of quantitative forecasting to assess the range of possibilities for future oil availability. Because of the importance of future oil supplies, forecasting is treated in greater-than-usual detail in this section and in Appendix F.

Many future oil production forecasts have been published. Guy Caruso, Administer of the Energy Information Administration, documents 38 different forecasts made between 1972 and 2004. The estimates of the year of peak oil production for all but two of these forecasts range from 1989 to 2050. Most range from 2010 to 2040⁴.

It should be noted that current oil extraction technology permits extraction of only about one-third of the oil in a reservoir. There is hope that new extraction technology will permit extraction of some of the remaining oil. Higher oil prices will make it economical to extract hard-to-get oil that was previously uneconomical.

The detail included in the published forecasting models varies enormously. Some are so simple that it is generous to call them a model⁵. Some are so involved that it is difficult to evaluate their plausibility⁶. The following sections describe two of the simpler approaches to forecasting. These were chosen because the link between underlying assumptions and predicted results

is transparent and because of the author's belief that quantitative estimation of the many factors that will determine future production and consumption is impossible.

Logistic Function Modeling

A technique called logistic function modeling⁷ may be used in oil production forecasting. The premise of logistic function modeling for an exhaustible resource is as follows:

Premise of logistic function modeling: The fractional rate of cumulative production of an exhaustible resource is proportional to the fraction of that resource which remains.

If Q represents the cumulative production at some point in time, P represents the production rate at that time, and Q_t represents the cumulative production that will have occurred at the time of resource depletion (the total reserves), then application of the logistic function modeling premise results in the following:

$$P/Q = a(Q_t - Q)/Q_t \quad (4-1)$$

where

a = a constant of proportionality

Equation 4-1 reveals that, according to the logistic premise, a plot of P/Q versus Q should be a straight line.

Figure 4-2 shows a plot of P/Q versus Q for the lower 48 states of the U.S. The latter part of the data approximates a straight line as predicted by the logistic premise.

There are various ways to solve Equation 4-1 for production, P . The most elegant method is based on recognition that Equation 4-1 is really a differential equation (P is the rate of change of Q or dQ/dt) with a known solution. The solution (details in Appendix F) is as follows:

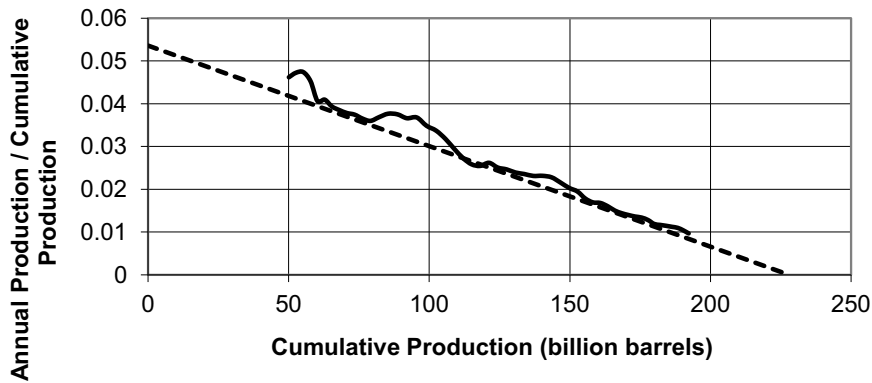

Figure 4-2. Hubbert Plot for U.S. Oil

$$Q = Q_t / [1 + e^{-at}] \quad (4-2)$$

where

t = time

A feature of the solution shown above is that time is measured from the instant when cumulative production is exactly half of the ultimate cumulative production (see Appendix F for details). Consequently, cumulative production values for times after the half production point are obtained by substituting positive values of t in Equation 4-2, and values for times before the half production point are obtained by substituting negative values of t .

M. King Hubbert^{8,9} used a variant of this approach in 1956 to forecast future oil production in the lower 48 states of the U.S. He predicted a production peak in the mid-1970s. The peak actually occurred around 1970. Figure 4-3 shows the Hubbert forecast from 1956 and actual production data for the U.S.

Hubbert is regarded by many as the master prognosticator of future oil production. Many learned papers have verified his method, dissected the nuances, and applied his method to other problems, especially world oil production. There have also been publications that debunked the Hubbert

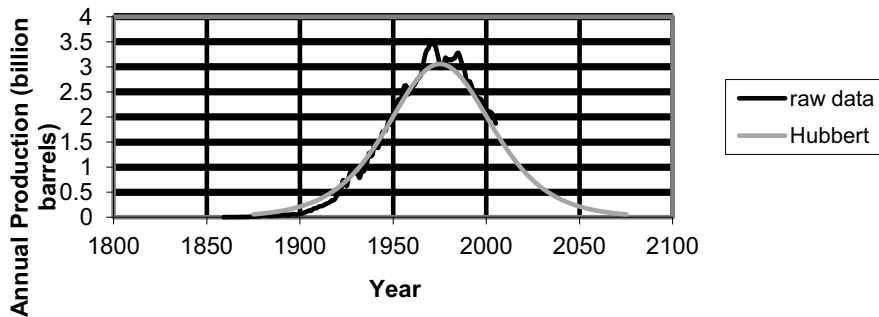

Figure 4-3. Hubbert Prediction and Actual U.S. Production

approach. Overall, Hubbert’s method has gained widespread acceptance. The predicted and observed peak in U.S. oil production is now called Hubbert’s peak, and he is honored with the formation of institutional centers devoted to the application and refinement of his method. One such center is the M. King Hubbert Center for Petroleum Supply Studies at The Colorado School of Mines. The importance of Hubbert’s method is apparent if one does a web search on “Hubbert’s peak” or “peak oil.”

Hubbert was successful in forecasting U.S. production through its peak in his 1956 work. There is now great interest in predicting future world production.

A plot of P/Q vs. Q for world oil is shown in Figure 4-4. This plot may be used to check for linearity and, if linearity is observed, to give confidence in the validity of using the Hubbert method for world oil forecasting. The figure shows actual data (for cumulative production to about 1,000 billion barrels) and projections for total resource estimates of 2,000 and 3,000 billion barrels. The figure shows that a clearly defined linear region is absent, thereby reducing confidence in reliance on a Hubbert projection for world oil. Nevertheless, a Hubbert analysis was performed for two cases: total reserves = 2,000 billion barrels, and total reserves = 3,000 billion barrels. The results appear in Figure 4-5. For reserves of 2,000 billion barrels, the estimated peak production year is 2010. For reserves of 3,000 billion barrels, the estimated peak production year is 2022. Regardless of the doubts about

the applicability of Hubbert's method for forecasting future world oil production, these results suggest the peak in world oil production has occurred already or will occur in the near future. Figure 4-6 shows cumulative oil production by the Hubbert analysis method.

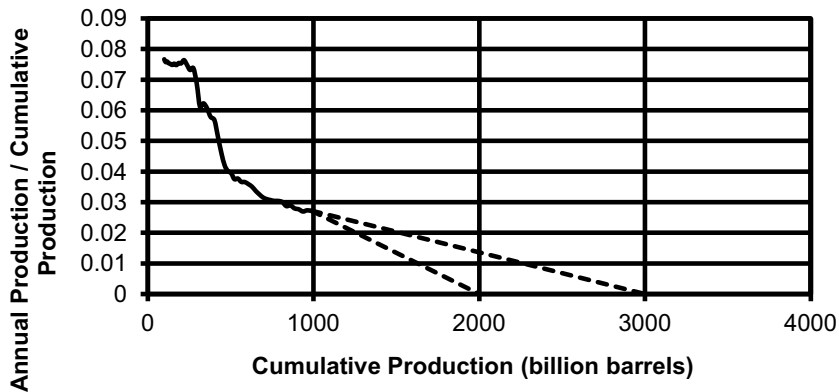

Figure 4-4. Hubbert Plot for World Oil

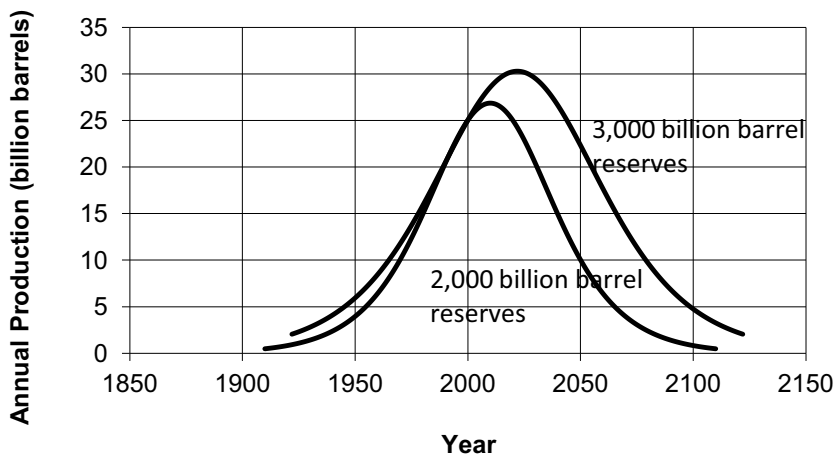

Figure 4-5. Effect of World Oil Reserve Estimate on Hubbert Annual Production Prediction

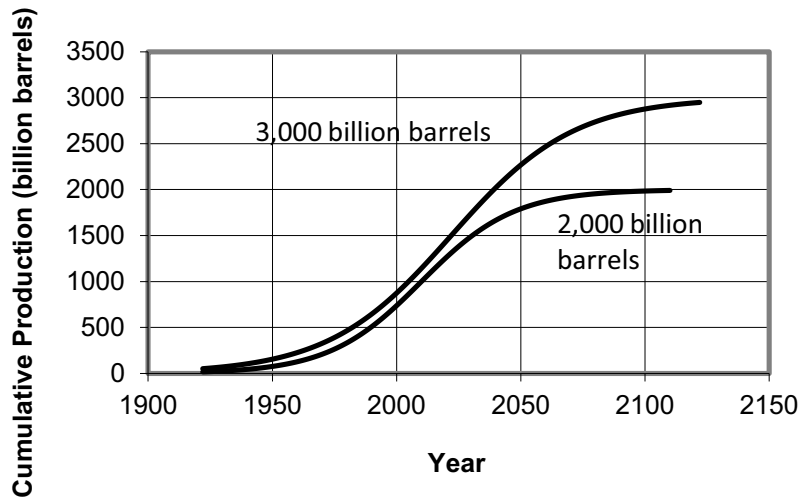

Figure 4-6. Effect of World Oil Reserve Estimate on Hubbert Cumulative Production Prediction

The EIA Model

A model was presented by Wood, Long, and Morehouse of the Energy Information Administration of the U.S. Department of Energy⁵. Their model is described here and is called the EIA model.

Forecasting by the EIA model is based on the assumption that annual production will continue into the future at a constant growth rate until annual production reaches some fraction of remaining reserves, then drops, with the continuing annual production rate equal to some assumed fraction of remaining reserves per year. Typical assumptions are a growth rate of 2 percent per year until annual production reaches 10 percent of remaining reserves, followed by production at 10 percent of remaining reserves per year. The EIA model assumes we will continue what we are doing until it is no longer possible to do so.

Figure 4-7 shows forecasts for annual production by the EIA model, and Figure 4-8 shows cumulative production for total reserve estimates of 2,000 and 3,000 billion barrels. The peak occurs in 2024 for reserves of 2,000 billion barrels, and in 2042 for reserves of 3,000 billion barrels.

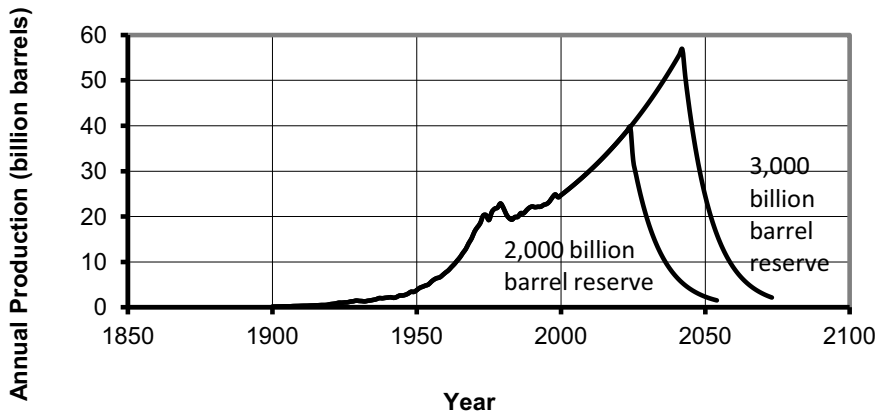

Figure 4-7. Effect of World Oil Reserve Estimate on EIA Annual Production Prediction

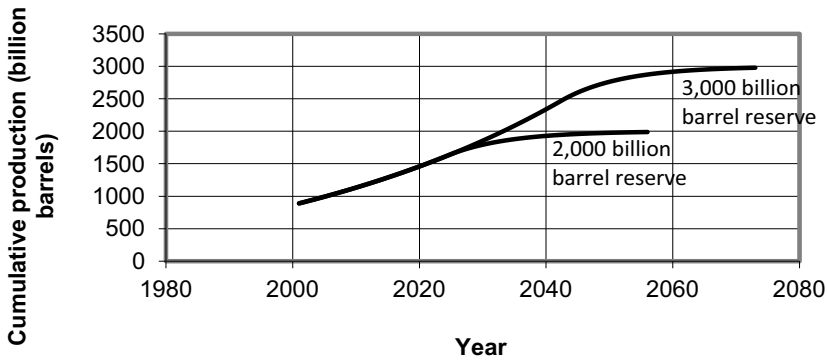

Figure 4-8. Effect of World Oil Reserve Estimate on EIA Cumulative Production Prediction

Assessment of World Forecasts

The models described above give estimates of future annual production and future cumulative production, but they differ in their treatment the underlying causes.

The Hubbert model predicts decreasing annual production as remaining reserves are depleted. It predicts production will start to decrease when exactly half of the reserves are depleted. This feature is consistent with the

logic that says that oil extraction will get more difficult as reservoirs are emptied. However, the perfect symmetry of the production curve is a simplification that is open to question. Hubbert's model is a "production constrained" model. The peak in annual production is the focus in a Hubbert analysis because predicted annual production subsequently decreases irrespective of the size of remaining reserves or the continuing demand. The peak in a Hubbert analysis signals the onset of inability to meet annual production requirements.

The Hubbert analysis predicted the peak of world oil production and the onset of supply shortfalls would occur in 2010 if the 2,000 billion barrel reserve estimate was correct and would occur in 2022 if the 3,000 billion barrel estimate is correct.

The EIA model assumes no natural constraints on annual production until depletion is almost complete. The EIA model is a "reserve constrained" model. Basically, the EIA model says oil will be extracted at the rate needed to satisfy demand. It assumes there are no limits on extraction rate due to geology or extraction technology. The peak in an EIA analysis is simply indicative of arrival at a point close to reserve depletion. The peak in an EIA analysis signals the end of business-as-usual and the onset of rapid reductions in annual production.

The EIA model predicts the onset of supply problems will occur in 2024 if the 2,000 billion barrel reserve is correct, and in 2042 if the 3,000 billion barrel estimate is correct.

The models predict nothing can be done to avoid world oil shortages after around 2020 or earlier if the total reserve estimate of 2,000 billion barrels is correct. If the 3,000 billion barrel estimate is correct, then the models predict shortages around 2040 or earlier.

There are major doubts about the validity of these models, but their results say total oil reserves, whether they total 2,000 or 3,000 billion barrels, will be unable to satisfy requirements after some time between 2010 and 2040 unless major and improbable consumption curtailments occur. 2040 may

seem far into the future for those who believe the 3,000 billion barrel estimate, but the long development and deployment time for alternative sources causes projected serious oil supply shortfalls to seem alarmingly close in time.

4.2.7 Oil Spills and the Environment

Experience has shown that oil spills can and do occur at well sites and during oil transport.

The largest accidental release at a well site occurred in the Gulf of Mexico in June 2010. The *Deepwater Horizon* operated in mile-deep water off the coast of Louisiana. An explosion destroyed the floating rig, broke the delivery pipe, and created a path at the sea floor for release of oil. Millions of barrels of oil were released. Major environmental and economic impacts resulted.

There have also been many spills resulting from accidents involving oil-carrying ships. The largest U.S. spill from an ocean tanker was from the *Exxon Valdez* incident in 1989. The ship ran onto a reef and spilled over 10 million gallons of oil into Prince William Sound, Alaska.

4.3 Oil Sand

Oils other than liquid crude oil are called unconventional oils¹⁰. Unconventional oils include kerogen, found in oil shale deposits, and bitumen, found in oil sand deposits. Kerogen and bitumen are complex mixtures of high molecular weight organic compounds. They are distinguished by their solubility in organic solvents and acids. Bitumen is soluble, and kerogen is not.

Unlike crude oil, natural gas, and coal, unconventional oils are mixed with large volumes of inorganic material that must be removed before the oil can be processed for ultimate use as a fuel. This unavoidably complicates extraction and processing operations and impacts the competitiveness of unconventional oils. However, they become increasingly competitive as

conventional energy sources become more expensive as they become scarce, and the cost of unconventional oil decreases as technology improves.

4.3.1 Importance of Oil Sands

Oil sands, also called tar sands or heavy oil, are a massive resource, containing a huge quantity of hydrocarbons. Oil sand can be mined and processed to yield gaseous and liquid hydrocarbons and an emulsion suitable as a coal replacement for power plants. If environmental and economic issues associated with oil sand mining and processing can be resolved, oil sand has the potential to extend world petroleum reserves significantly.

4.3.2 Origins of Oil Sand

The bitumen in oil sand is organic material that is one of the intermediate materials in the complex series of transformations of buried biomass into fossil fuel. Its precursor is kerogen (see below) and, if it were left at high temperature and pressure for a sufficient time, its decomposition would result in crude oil and natural gas.

4.3.3 Oil Sand Properties

Bitumen is a complex mixture of chemicals that typically contains (by weight) around 80 percent carbon, 10 percent hydrogen, and less than 10 percent oxygen, nitrogen, and various impurities, some of which, such as sulfur, create problems when they are burned.

The hydrogen-to-carbon atomic ratio for the hydrocarbons in oil sand is around 1.5. If the oil sand is to be processed into liquid hydrocarbon fuel, sufficient hydrogen must be added or carbon removed to yield hydrocarbons with hydrogen-to-carbon ratios of around two.

4.3.4 Oil Sand Mining and In-situ Extraction

Oil sand may be mined by strip mining or in-situ liquefaction and extraction by pumping.

In strip mining, huge quantities of a mixture of bitumen, sand, and clay are extracted from deposits at—and near—the surface. After the bitumen is separated in processing facilities, large volumes of waste material remain. This material may be returned to the pits from which it was extracted to minimize permanent environmental effects.

In-situ extraction involves heating of the oil sand while it is still in the ground. This liquefies the bitumen, permitting it to be pumped to the surface. This heating can also modify the composition of the bitumen by breaking large molecules into smaller molecules.

4.3.5 Oil Sand Processing

The processing of strip-mined oil sand occurs in two steps: separation of the bitumen from the other materials in the ore and transformation of the bitumen hydrocarbons into other hydrocarbons with more useful properties.

The solid bitumen from strip-mined oil sand or the liquefied oil from in-situ extraction may be converted into lower molecular weight hydrocarbons by cracking, and the hydrogen-to-carbon ratio can be increased to around two by catalytic hydrogenation.

Large deposits of oil sand exist in the Orinoco Basin in Venezuela. The Venezuelans have developed a novel process for using their oil sands. After it has been separated from the inorganic matter, bitumen is mixed with water and an emulsifier to produce a material called Orimulsion that can be pumped. It is suitable for combustion in boilers, providing a fuel that can replace coal or heavy fuel oil in producing electricity.

4.3.6 Oil Sand Reserves

The largest known deposits of oil sand are in Alberta, Canada, and in Venezuela. The estimated recoverable reserves in these two areas are about 3.6 trillion barrels of oil equivalent. The main known U.S. oil sand deposit is in Utah, with estimated reserves of 12 to 20 billion barrels of oil equivalent.

4.3.7 Environmental Effects

The environmental consequence of mining and processing oil sand is a huge issue. The list of environmental concerns is:

- Ecosystem disruption
- Greenhouse gas released during mining and processing
- Air pollution
- Surface water pollution
- Ground water pollution
- Water consumption
- Alteration of surface features

Some environmental groups are mounting campaigns to restrict or prohibit oil sand mining and processing.

4.4 Oil Shale

4.4.1 Importance of Oil Shale

Like oil sand, oil shale deposits represent a huge potential energy resource¹¹. Unlike oil sand, the oil shale deposits are mostly in the U.S. Pro-

cesses are available for converting oil shale into liquid transportation fuel, but there are major cost and environmental issues to be considered.

There have been several attempts in the past to exploit oil shale, especially when crude oil prices were high, but most efforts were subsequently abandoned in the face of high production costs and lower oil prices. Now, with higher crude oil prices, and with supply deficiencies approaching, interest in the oil shale resource is increasing. This increased activity has stimulated some environmental groups to speak out about the undesirable environmental effects related to oil shale extraction and processing.

4.4.2 Origin of Oil Shale

The kerogen in oil shale, like the bitumen in oil sand, is an intermediate compound in the series of chemical transformation involved in converting biomass into crude oil. In the geological process that results in crude oil, kerogen is formed, and then it is transformed into bitumen, which is a precursor to oil. Bitumen and kerogen exist because the conditions and time elapsed were insufficient for their transformation into oil.

4.4.3 Oil Shale Properties

Like the bitumen in oil sand, the kerogen in oil shale has a hydrogen-to-carbon atomic ratio of around 1.5. Hydrogen must be added or carbon removed to yield a hydrogen-to-carbon ratio of around two as needed for liquid hydrocarbon fuels.

4.4.4 Oil Shale Mining

Like oil sand, oil shale may be extracted by strip mining or by in-situ liquefaction and extraction by pumping. However, oil shale mining is more difficult than oil sand mining since the hydrocarbon is contained in rock rather than sand.

4.4.5 Oil Shale Processing

Like oil sand, oil shale is processed by cracking and catalytic hydrogenation after separation from the associated rock by crushing and washing.

4.4.6 Oil Shale Reserves

The estimated world reserve of oil shale is around 3 trillion barrels of oil equivalent. (Some prefer to call oil shale deposits “contingent resources” rather than reserves. This is to acknowledge that economical recovery methods are still unavailable¹².) The largest reserves are in the U.S., where the estimate is over 2 trillion barrels. The largest U.S. deposits are the Green River Formation in Colorado, Wyoming, and Utah.

4.4.7 Environmental Effects

Oil shale mining and processing have all of the environmental concerns previously listed for oil sand. In addition, in the surface heat treating of oil shale, the waste material undergoes expansion, creating more volume than was initially extracted and preventing restoration of the mined area to its original topography.

4.5 Gaseous Hydrocarbons

4.5.1 Properties

Natural gas, the current dominant gaseous fuel, is extracted from the earth, often along with crude oil. It is a mixture of gaseous hydrocarbons (typically 80 percent methane, CH_4 ; 7 percent ethane, C_2H_6 ; 6 percent propane, C_3H_8 ; 4 percent butane and isobutane, C_4H_{10} ; and 3 percent pentanes, C_5H_{12}). The gases with three or more carbon atoms are removed from natural gas before it is delivered for use as a commodity fuel. Consequently, the gases in consumed natural gas are methane and ethane. The propane and butanes are suitable for liquefaction under pressure. This facilitates their portability for use as a fuel.

Natural gas is compressible, so the specification of gas quantity requires specification of the temperature and pressure. The convention is to use the standard cubic foot, commonly defined in the U.S. as gas at 60°F and at atmospheric pressure, 14.7 pounds per square inch. The high heating value of natural gas varies for gas extracted from different wells, but typical values are around 1030 BTU per cubic foot for the high heating value and around 930 BTU per cubic foot for the low heating value.

Methane, the major component of natural gas, is a colorless, odorless gas. It has the formula CH₄. Combustion of methane yields carbon dioxide and water as follows:



Natural gas and oxygen can also be used to power a fuel cell, in which the energy produced is electricity. A fuel cell is basically a battery into which the reactants are fed continuously. Whether natural gas is used for combustion or for powering a fuel cell, the reaction products are carbon dioxide and water. Natural gas fuel cells are a candidate for widespread use as local electricity producers for homes and businesses, thereby eliminating the need for delivery of electricity by the grid.

Since methane occurs naturally as a component of natural gas and as a result of anaerobic digestion of biomass, it is appropriately considered to be both a non-renewable and a renewable energy source. In addition, methane can be manufactured from other hydrocarbons, from coal or from carbohydrates. Manufactured methane is an energy carrier.

Some methane-producing processes also result in the production of carbon monoxide. Carbon monoxide is a colorless, odorless, toxic gas. Its toxicity complicates the use of gases containing carbon monoxide. Carbon monoxide has the chemical formula CO. Combustion of carbon monoxide yields carbon dioxide as follows:

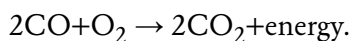

Combustion of carbon monoxide yields 340 BTU per standard cubic foot. The distinction between high heating value and low heating value does not apply to carbon monoxide because no water is produced in combustion. The heat release from carbon monoxide combustion is around one-third the heat release from methane combustion.

Hydrogen is another gaseous fuel with huge potential importance. Since hydrogen is a highly reactive chemical, it readily forms compounds with other chemicals. Because of its tendency to form compounds, elemental hydrogen gas does not exist in nature. Hydrogen may be produced from hydrogen-bearing compounds by supplying the energy needed to break up the compounds. Consequently, hydrogen is an energy carrier rather than an energy source. Chapter 12 addresses hydrogen as a fuel.

4.5.2 Unconventional Gas

Conventional gas is that which requires only drilling a well into a gas-bearing underground formation. Conventional gas wells are typically no deeper than a few thousand feet. Conventional gas flows to the well through formations that have enough permeability to permit substantial flow.

“Unconventional” gas is that which is more difficult to access and extract, requiring application of technology as described below.

Exploitation of the huge U.S. reserves of unconventional gas has already begun. The size of the unconventional gas resource and the quantities that can be extracted economically are very uncertain. However, it is known that the U.S. reserves are large, possibly 10 times the reserves of proved gas or greater. If fully exploited, unconventional gas could satisfy consumption demand at the current rate for a century or longer.

There are several different types of unconventional gas. The unconventional gases that are receiving the bulk of current attention are shale gas, tight gas, coalbed gas, and methane hydrates. In addition, large quantities of two other types of unconventional gas, deep gas and geopressurized gas, are known to exist and may eventually become important.

The six types of unconventional gas are discussed below.

Shale Gas

Shale gas is gas contained in shale deposits. These lack the permeability needed to allow gas flow through the deposit to a well. Accessing shale gas requires intervention to fracture the shale. Shale gas is increasing in importance because of advances in hydrofracturing technology, horizontal drilling technology, and increased competitiveness with conventional gas.

Hydrofracturing enables extraction of large quantities of natural gas that is inaccessible by conventional drilling. Hydrofracturing for natural gas uses essentially the same technology as that used for extracting oil (see Section 4.2.3), but, since natural gas is less viscous than oil, it flows more easily through fracture zones. Natural gas extraction using hydrofracturing technology has grown rapidly and has become a major contributor to total gas production in the U.S. in the early twenty-first century.

The environmental concerns related to natural gas hydrofracturing are the release of gas and other chemicals into the groundwater, the release of gas into the air, the escape of gas into human habitats, and the improper handling of backflow water. There have been numerous well-publicized environmental, health, and safety incidents near gas hydrofracturing sites.

Tight Gas

Tight gas is gas contained in unusually low-permeability deposits, typically hard rock or non-porous limestone. Tight gas extraction depends on creation of porous pathways for gas flow. Pathways can be created by hydrofracturing or by injecting acid that dissolves part of the rock.

The environmental concerns are the same as with shale gas.

Coalbed Gas

Coalbed gas is methane that resides on seams or joints in coal deposits or is absorbed in pores in coal. Groundwater under elevated pressure holds the methane in place. Coalbed gas is a safety consideration in coal mining, and mines are vented to avoid gas explosions.

Groundwater and associated coalbed gas are released from the coal matrix when the pressure on the coal is reduced. When a well penetrates a coal seam, a low pressure region is created, permitting gas and the associated groundwater to flow to the well and then to the surface. The rate of flow depends on the permeability and porosity of the coal bed. Coal seams that are naturally fractured provide the best source of coalbed methane.

Methane Hydrate

Methane hydrate, also called methane clathrate, is a solid form of water that contains methane in its molecular structure¹³. Clathrates are substances in which a molecule resides in a cage made of other molecules. Methane hydrate is similar in appearance to normal water ice.

Methane hydrate occurs in oceans at depths of 1,000 to 6,000 feet and in some rocks on land. The quantity of methane hydrate in these deposits is uncertain, but potentially large.

Methane hydrate is considered an energy resource by some, but methods for acquiring it are not available and release to the atmosphere during collection is problematical because methane is a greenhouse gas with over 20 times the impact per molecule as carbon dioxide. Researchers are exploring ways to access this energy resource in safe and environmentally acceptable ways.

Deep Gas

As the name suggests, deep gas is gas located in deposits that are deeper than sources of conventional gas. Deep gas deposits are typically at depths of 15,000 feet or greater.

Geopressurized Gas

Geopressurized gas is gas in deep formations (10,000 to 25,000 feet) that are under very high pressure.

4.5.3 Methane Derivatives

Methane is currently the main source material for producing hydrogen. Methane also serves as a feedstock for production of various chemicals. As is discussed in Section 4.7, hydrocarbons can be produced by reactions involving methane, oxygen, and water. Hydrogen produced from methane may be used as a fuel or in the production of chemicals.

4.5.4 Natural Gas Reserves and Forecasts

As seen in Figures 3-3 and 3-4 in the previous chapter, U.S. natural gas production and consumption history is quite different than U.S. oil production and consumption history. There are no trends that would warrant a detailed forecast of future consumption. U.S. consumption has fluctuated around 23 trillion cubic feet per year since the mid-1990s.

The proved reserves of domestic conventional and unconventional U.S. natural gas in 2011 were 284 trillion cubic feet. At the current consumption rate, 284 trillion cubic feet will last around 12 years. However, it is now believed that much more natural gas is economically recoverable in the U.S., primarily as unconventional gas. Unconventional gas is already a major part of U.S. gas production.

In recent years the rate of developing new proved reserves has essentially matched the rate of consumption. There are much larger reserves of natural gas in other countries, but using domestic resources rather than depending on foreign suppliers ensures security of supply and reduces foreign expenditures.

Natural gas is a versatile energy source. It is well-suited for heating applications in homes, industries, and businesses, and it is the cleanest-burning fossil fuel. It is used heavily as a feedstock for producing chemicals. It also sees limited use for transportation energy.

Some say natural gas is abundant. This statement is based on the likelihood that huge U.S. reserves of unconventional gas can be extracted at acceptable

cost and with acceptable environmental impact. Recent experience and steady advances in unconventional gas extraction technology provide a basis for confidence that gas will truly be abundant in the U.S. for many decades. However there are serious concerns about environmental, health, and safety impacts of gas extraction. Also, natural gas use produces carbon dioxide, though at a lower level than other hydrocarbons. These issues may constrain the future use of natural gas.

4.6 Coal

4.6.1 Importance of Coal

Coal is a huge and widely distributed energy resource. Before World War II, it was widely used for electricity production, heating, and transportation. As oil and natural gas grew in importance after World War II, electricity production became the dominant use for coal (about 90 percent of U.S. coal consumption is for electricity). Coal now provides about 75 percent of U.S. electricity.

Estimated remaining U.S. recoverable coal reserves are about 250 billion tons. The energy contained in these reserves is about 5,000 Quads. Estimated world recoverable coal reserves are about 1 trillion tons, with an energy content of about 20,000 Quads.

About 10 percent of coal in the U.S. is used as a feedstock to make coke (primarily used in steelmaking), to produce syngas (which consists mainly of hydrogen and carbon monoxide), or to produce synthetic liquid hydrocarbons.

4.6.2 Origin of Coal

Coal was formed from plants that grew in swampy areas millions of years ago. The natural process that formed coal is called coalification. Dead plants fell into oxygen-poor aquatic environments that inhibited decay. Eventually, sediment covered the dead plant material. The resulting heat

and pressure compacted the material, drove out water (including water driven out of the molecules of the plant matter), and drove out hydrogen and methane gases from the plant matter. These processes required millions of years. Various forms of coal were formed as a result of various levels of completion of the coalification process.

4.6.3 Coal Properties

The types of coal are usually ranked according to their state in the coalification process. Higher ranked coals contain less water, more carbon relative to hydrogen and oxygen, and more energy release per pound that is burned. The carbon content and energy rankings, from lowest to highest, are as follows:

Table 4-2. Coal Properties¹⁴

Type of Coal	Carbon (%)	Water (%)	Energy Content (million BTU/ton)	
			World	U.S. Average
Lignite	25–35	up to 45	9–17	13
Subbituminous	35–45	20–30	17–24	17–18
Bituminous	45–86	<20	21–30	24
Anthracite	86–97	<15	22–28	25

The carbon in coal, which amounts to the largest fraction of the components in mined coal, is made up of complex molecules comprised mostly of carbon. Coal is found along with varying amounts of other materials. These may be materials mixed with the coal or elements that are part of the complex coal molecules. Typical materials found mixed with coal are water, clay, sand, and rock. Many chemicals may be found in coal, but some of the most troublesome are sulfur, nitrogen, and heavy metals.

Coal energy content varies with coal type, but most coal used for electricity production (subbituminous and bituminous) releases around 20 million BTU per ton when burned.

4.6.4 Coal Mining

Coal is obtained from underground mines and surface mines. In the U.S., about two-thirds of the coal is obtained from surface mines and one-third from underground mines. Coal is mined in three main regions: the eastern Appalachian region, the midwestern region, and the western region. Huge surface mines in the western region produce low-sulfur, subbituminous coal that is hauled by train to electrical plants throughout the country.

4.6.5 Coal for Electricity Production

Coal is widely used to produce electricity. The environmental consequences of coal combustion affect the design and operation of modern coal-fired power plants (see Figure 4-9).

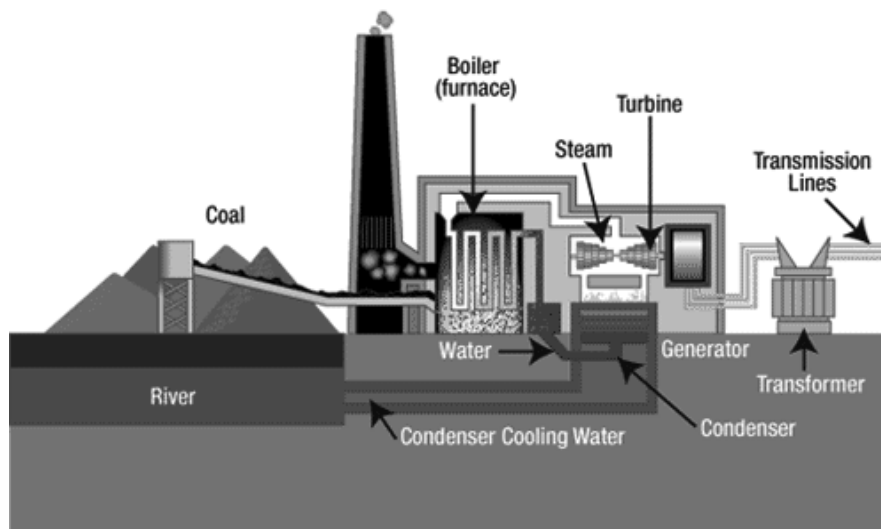

Figure 4-9. A Coal-Fueled Power Plant (courtesy of Tennessee Valley Authority)

Steps are taken before and after combustion in an electric power plant to reduce emissions associated with coal combustion. Coal with a significant content of sand, clay, and/or rock may be washed to remove these materials before use. Removal of these non-combustibles reduces subsequent ash pro-

duction. After combustion, filters and/or electrostatic precipitators may be used to reduce emissions of fly ash (small particulates in the exhaust gas), and scrubbers (alkaline wet slurry) may be used to reduce emissions of oxides of sulfur and nitrogen.

Large baghouse filters are sometimes used to remove particulates, but they cause pressure drops that reduce exhaust flow and plant efficiency, and they require cleaning and regular replacement. Electrostatic precipitators remove particulates without these adverse effects. They operate by inducing negative electric charges on the fly ash particles, then collecting the particles on positively-charged plates.

Before its introduction into the boiler, the coal is pulverized to the consistency of talcum powder. The boiler is a large box-like structure. Combustion occurs in the interior, and the resulting heat is transferred to water flowing through tubes located in the boiler walls and in the hot gas stream.

Coal combustion results in ash, unburned constituents of the coal. Deposits, called slag, also form on boiler tubes, requiring removal and disposition. Ash and slag contribute to the solid waste stream from the plant, which must be disposed of in an environmentally acceptable manner.

Even with the most efficient clean-up equipment, the combustion of coal releases carbon dioxide and pollutants into the environment. Fly ash in the air is an irritant to eyes and lungs. Oxides of sulfur and nitrogen interact with water in the atmosphere to produce acid rain. Heavy metals, including mercury, and radioactive materials, including uranium and thorium, are released. These problems have led to the development of new ways to use coal with less environmental impact (see Section 4.6.7).

4.6.6 Derivatives

The main products derived from coal are coke, syngas, and synthetic liquid hydrocarbons.

Coke is the result of baking low-sulfur, low-ash bituminous coal at temperatures as high as 2000°F. Volatile components are driven off, leaving a fused hard, gray porous residue of carbon and ash. Coke is used as a fuel and as a reducing agent for smelting iron ore in blast furnaces.

Syngas, a mixture of gases comprised mostly of hydrogen and carbon monoxide, is produced by reacting hot coal with steam. It may be converted into liquid hydrocarbons as described in Section 4.7.

4.6.7 Advanced Power Plant Designs

A large part of the environmental impact of coal combustion is the carbon dioxide and the pollutants in the gases released from the smokestack. Several new designs use coal to produce syngas. These designs minimize the carbon dioxide emissions.

One new concept uses coal to produce syngas followed by the water shift reaction to produce hydrogen and carbon dioxide. The hydrogen produced is subsequently used to fuel a gas turbine or a fuel cell. The idea is to use a reaction between coal and steam to make hydrogen (see Section 4.7).

The hydrogen is separated from the carbon dioxide and then fed as fuel to a gas turbine power plant or a fuel cell. Of course, carbon dioxide is still produced, but its isolation does not require separation from large quantities of nitrogen as would be needed following the combustion of coal in air. Designers envision pumping the carbon dioxide into underground reservoirs. This process is called carbon sequestration. Its practicality for large-scale carbon dioxide storage is unproved.

4.6.8 Coal Reserves, Production, and Forecasts

The estimated remaining reserve of recoverable coal in the U.S. is around 250 billion tons, out of the recoverable reserve of about 319 billion tons underground when coal mining began. Annual production is about 1.1 billion tons and, as of 2005, the cumulative production was about 69 billion

tons. Figures 3-5 and 3-6 in the previous chapter show U.S. annual production and cumulative production.

Forecasters often state, “At the current rate of consumption, coal will last for 250 years.” This is true, but somewhat misleading. Consumption certainly will not continue at the current rate. Concerns about pollution, climate change, the growth of renewable fuel, and/or nuclear energy use may reduce coal consumption significantly. On the other hand, new clean coal technologies and/or the inadequacy of alternatives may increase coal use significantly.

4.6.9 Environmental, Health, and Safety Issues

Although carbon dioxide release is the major environmental concern related to coal use, there are also other concerns related to coal extraction and use.

Coal mining in Appalachia has resulted in major undesirable effects. Mountaintops have been stripped off to reach coal deposits. Tailings, the excess material removed during mining, have been left on the surface where rainwater reacts with constituents to form acids that run into streams, killing fish and aquatic plants.

Coal mining has also historically taken a toll on the mineworkers. Black lung disease has caused the illness and death of thousands of miners. Mine accidents have taken many lives. The National Institute of Occupational Safety and Health has documented over 600 accidents with five or more fatalities between 1839 and 2010¹⁵. The main cause, by a wide margin, was explosions.

Coal mining operations now must comply with restrictions that reduce or eliminate environmental damage and increase mine safety, but concerns about the adequacy of environmental protection and safety practices persist.

Power plant operation results in huge quantities of ash and slag. This solid waste is stored at on-site storage facilities. The possibility of environmental catastrophe was demonstrated by the ash spill at the Kingston Plant in Tennessee in December 2008. Ponds containing ash slurry failed, releasing 1.1 billion gallons into the environment. The slurry flowed onto surrounding land and into the nearby Emory River. Cleanup and restoration required a large and expensive effort.

4.7 Synthetic Liquid Fuels

Liquid fuels currently provide almost all of the energy used for transportation and will continue to be important in the future. The materials best suited for transportation applications are hydrocarbons with five to 17 carbon atoms per molecule, and certain alcohols. These compounds are liquid at normal temperatures and release significant quantities of energy upon combustion.

Some of the hydrocarbons in crude oil have the desired properties and are obtained by separation from the other components of crude oil. Obtaining desired liquid fuels from sources other than the suitable fraction of crude oil requires processing to alter the materials' chemical properties.

It has been said that it is possible to make almost any organic chemical from any other organic chemical. Certainly, a number of processes have been developed that can convert organic materials into different, more useful materials. The processing must begin with available compounds that contain carbon and/or hydrogen. Oxygen also plays a role, either in the feedstock, in intermediate steps in processing, or as a component of alcohol fuels. The four sources of carbon are oil, natural gas, coal, and biomass. (Some also say carbon in atmospheric carbon dioxide is a potential source material for producing fuel.) The four sources of hydrogen are oil, natural gas, water, and biomass. The oil source material is now predominantly crude oil, but it could be augmented or replaced by oil from oil sands or oil shale.

Processing generally involves breaking the source compounds apart and then reassembling the parts into new, desired products.

The breaking of source compounds usually requires high temperature, high pressure and/or catalyst-assisted processes. The processes are known by a variety of names, including pyrolysis, gasification, retorting, cracking, and thermal depolymerization.

Pyrolysis is the thermal disassembly of molecules in the absence of oxygen.

Gasification is the thermal disassembly of molecules in the presence of limited oxygen.

Retorting is the modification of chemical compounds through the application of heat.

Cracking is the conversion of large hydrocarbon molecules into an array of lower molecular weight hydrocarbons. The resulting lower molecular weight hydrocarbons are then processed further, including reacting with hydrogen to increase the hydrogen-to-carbon ratio as needed to provide suitable liquid fuels.

Thermal depolymerization is the disassembly of high molecular weight molecules through the application of heat.

Syngas, a mixture of hydrogen and carbon monoxide, is useful as a fuel and as a source material for producing liquid fuels. Syngas can be made from any fossil fuel and from biomass. Hydrocarbons and alcohols can be produced from syngas using thermochemical processes or by fermentation (though the fermentation process is in the developmental stage). Syngas is hugely important because of its role as an intermediate in many of the currently-envisioned processes for producing liquid synthetic fuels.

Syngas can be produced from methane and steam by the following reaction (called steam reforming):

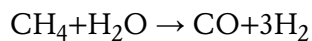

Heating methane in the presence of oxygen at levels inadequate to cause complete oxidation also yields syngas:

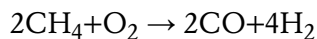

Syngas can also be produced from coal. The steam reforming reaction in the carbon in coal to produce syngas is:

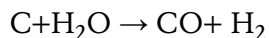

It is also possible to maximize hydrogen production via a reaction between carbon monoxide and water, called the “water shift reaction,” as shown below:

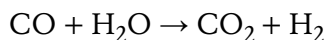

For steam reforming of methane followed by the water shift reaction, the overall reaction is:

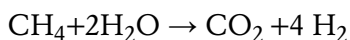

That is, reacting one atom of methane with two molecules of water yields four molecules of hydrogen.

For steam reforming of carbon followed by the water shift reaction, the overall reaction is:

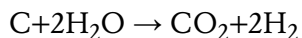

That is, reacting one atom of carbon with two molecules of water yields two molecules of hydrogen.

Most of the hydrogen currently produced comes from methane. Future hydrogen production will have to shift to other processes if hydrocarbon consumption is to be minimized.

A process for producing various compounds of carbon, hydrogen, and oxygen from syngas in the presence of iron or cobalt catalysts was invented by Franz Fischer and Hans Tropsch in Germany in the 1920s. From a fuel production standpoint, the most important Fischer-Tropsch products are hydrocarbons and alcohols. The basic chemical processes for producing hydrocarbons from carbon monoxide and hydrogen are as follows:

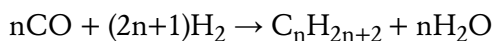

and:

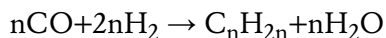

where n is an integer.

The chemical formula for producing alcohols from carbon monoxide and hydrogen is as follows:

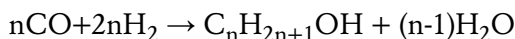

The Fischer-Tropsch process results in heat release and a mixture of reaction products. The relative proportions of reaction products obtained depend on the catalyst used, the catalyst physical state, and process conditions. Many variations of the Fischer-Tropsch process optimize the production of desired products, but all Fischer-Tropsch processes produce a mixture of products.

Dimethyl ether can be produced from methanol obtained by Fischer-Tropsch synthesis of syngas. Dimethyl ether or DME (CH_3OCH_3) has the same chemical formula as ethanol, but a different molecular structure. DME can be used as a fuel. Since its boiling point at atmospheric pressure is -13°F (-25°C), DME is a gas at atmospheric pressure and ambient temperature. However, it can be liquefied at modestly elevated pressure. The heat-

ing values of liquid DME are around 12,400 BTU per pound (LHV) and 13,600 BTU per pound (HHV).

DME can be produced by the catalytic dehydration of methanol as shown below:



Therefore, the steps in dimethyl ether production are syngas production, methanol synthesis, and conversion of methanol to dimethyl ether.

The use of DME as a fuel for Diesel engines is under investigation and development.

Another possible use of syngas is the production of hydrocarbons by the Mobil Oil M-gas process. In this process, dimethyl ether is produced (as shown above) from Fischer-Tropsch methanol and then processed catalytically to accomplish further dehydration. The result is hydrocarbons of various carbon chain lengths. One such reaction is between dimethyl ether and methanol:

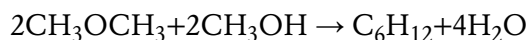

The general purpose of the syngas to hydrocarbon reactions in the M-gas process is to eliminate oxygen and achieve a hydrogen-to-carbon ratio of about two in the resulting molecules.

Natural gas can serve as the source material for syngas to be used in Fischer-Tropsch synthesis of synthetic liquid fuels. Also, a newer process is based on cracking of methane to produce acetylene, followed by hydrogenation to produce ethylene. The ethylene is then processed to yield longer-chain hydrocarbons as needed for liquid fuels. Developers of this technology claim that it is superior to the Fisher-Tropsch processes for gas-to-liquid fuel synthesis¹⁶.

Coal also may be converted directly to liquid hydrocarbons by pyrolysis or by catalytic hydrogenation of the carbon in the coal.

Pyrolysis of coal involves heating it to around 800°F in the absence of oxygen, then condensing the resulting gas. Oil was produced by pyrolysis of coal in the nineteenth century, before cheap petroleum became available. A process for coal pyrolysis, called the Karrick process, was patented in the early twentieth century.

Several processes have been developed for coal hydrogenation. The earliest process was the Bergius process. Hydrogen produced from coal and steam, or methane and oxygen, is reacted with the carbon in coal at high temperature and pressure to yield hydrocarbons.

Many different processes that use some variation of the technology described above have been developed and implemented.

4.8 Fossil Fuel Summary

An impressive body of technology exists for finding, extracting, modifying, and using fossil fuels. Oil provides our dominant transportation fuel. Natural gas provides a convenient heating fuel and serves as a feedstock for many chemicals. Coal provides most of our electricity. Oil sands and oil shale constitute large potential energy resources.

But the future for all of these energy sources is in question. Oil will become scarce in years or decades. Huge reserves of unconventional natural gas exist in the U.S., possibly extending adequate availability for up to a century, but environmental impacts may limit its use. Coal is also plentiful, but its use also causes environmental effects that may limit its use. Economical and environmentally acceptable acquisition of oil from oil sands and oil shale remains a challenge.

Transitioning from heavy reliance on fossil fuel to cleaner and more sustainable energy sources will take time and commitment. Fossil fuels will be a

significant part of our energy supply for at least decades into the future. The technologies described in this chapter, along with others that will surely appear, will be needed for providing needed fuel as cleanly and economically as possible.

References

1. Scripps Institute of Oceanography <http://earthguide.ucsd.edu/fuels/oil.html>
2. Glasby, G. P. "Abiogenic Origin of Hydrocarbons: An Historical Overview" *Resource Geology*, Vol. 56, No. 1, 2006 pp. 85-98.
3. Energy Information Administration report "Petroleum: An Energy Profile 1999" *DOE/ELA-0545(99)*, July 1999.
4. Caruso, G. "When Will World Oil Production Peak?" Tenth Annual Asia Oil and Gas Conference, Kuala Lumpur, Malaysia, June 2005. www.eia.doe.gov/neic/speeches/Caruso061305.pdf.
5. Wood, J. H., Long, G. R. and Morehouse, D. F. "Long-Term Oil Supply Scenarios," Energy Information Administration, August 18, 2000 available at <http://www.eia.doe.gov>.
6. Greene, D. L., Hopson, J. L. and Li, J. "Running Out of and Into Oil: Analyzing Global Oil Depletion and Transition Through 2050" *Oak Ridge National Laboratory Report ORNL/TM-2003/259*, October 2003.
7. Wikipedia *The Logistic Function* at http://en.wikipedia.org/wiki/Logistic_function.
8. De Sousa, L. "Hubbert's Peak Mathematics" <http://wapd.wuthwering-heights.co.uk/subpages/hubbertmaths/hubbertmaths>.
9. Deffeyes, K. S. "Beyond Oil" New York: Hill and Wang 2005.
10. U.S. Bureau of Land Management and Argonne National Laboratory "About Tar Sands" at <http://ostseis.anl.gov/guide/tarsands>.
11. U.S. Department of Energy, "America's Oil Shale" December 2004. http://fossil.energy.gov/programs/reserves/npr/publications/oil_shale_roadmap.pdf.
12. Andrews, A. "Oil Shale: History, Incentives and Policy" *Congressional Research Services Report Order Code RL33359*, April 2003.

13. U.S. Geological Survey “Gas (Methane) Hydrates-A New Frontier” at <http://marine.usgs.gov/fact-sheets/gas-hydrates/title.html>.
14. Energy Information Administration report “Coal Basics 101” at www.eia.doe.gov/basics/coal_basics.html.
15. National Institute for Occupational Health and Safety: <http://www.cdc.gov/niosh/mining/statistics>.
16. SynFuels: <http://www.synfuels.com>.

Exercises

- 4-1. All hydrocarbons produce around 20,000 BTU per pound when burned. Compare the carbon dioxide release for burning methane (CH_4 and 75 percent carbon by weight) and octane (C_8H_{18} and 84.2 percent carbon by weight) in pounds of carbon dioxide per pound consumed.
- 4-2. Use the Internet to learn how oil exploration is performed. Prepare a summary of methods used.
- 4-3. Use the Internet to find a current projection of world recoverable oil reserves. Discuss the plausibility of the projection and the implications for future society.
- 4-4. The Hubbert method worked well for U.S. oil production. Discuss the potential of the method for predicting world oil production.
- 4-5. Assume new discoveries raise the recoverable oil reserves in the ground at the onset of oil extraction to 4 trillion barrels. Perform a Hubbert analysis. When does the peak occur? Hint: Appendix F provides information related to this exercise.
- 4-6. The Hubbert model says production drops steadily after half of the reserves are used. The EIA model says oil production increases steadily until almost all of the reserves are exhausted. Discuss the

relative plausibility of the two models. Can you suggest an alternate model?

- 4-7. Use the Internet to discover the current status of oil sand use. Pretend you are a journalist for a newspaper and prepare an article on the status, prospects, and environmental consequences of the widespread use of oil sand.
- 4-8. Repeat problem 4.7 for oil shale.
- 4-9. New technology for extracting natural gas involves hydrofracturing gas-bearing rock formations. The process is often called “fracking.” There have been reports of severe environmental problems associated with fracking, including gas in well water and pollution by the chemicals used in the fracking process. Use the Internet to discover the current status of fracking for gas and the environmental consequences. Pretend you are a journalist for a newspaper and prepare an article on the subject.
- 4-10. Use the Internet to discover the current status of methane hydrate as a practical energy source. Discuss your findings.
- 4-11. A problem with using coal is the release of carbon dioxide and various pollutants. Capturing and burying the released carbon dioxide is called *sequestration*.
- A. Use the Internet to discover the new plant designs that facilitate sequestration. Discuss.
- B. Use the Internet to discover the current status of sequestration technology, including predicted capacity, proximity of carbon dioxide sources, and permanence of isolation from the atmosphere.
- 4-12. Discuss the importance of syngas in the production of transportation fuel.

- 4-13. Oil shale has a hydrogen-to-carbon ratio of around 1.5. If it is hydrogenated with methane to achieve a hydrogen to-carbon-ratio of two, how much methane (in pounds and kilograms) is needed per ton of hydrogenated product?

5

Renewables

The Main Points

- **The sun is the source of energy available in biofuels, as wind energy, as solar energy, and as hydroenergy.**
- **The average solar energy absorption by the earth is well known (about 1280 BTU per day per square foot).**
- **The average surface area needed to absorb a Quad of solar energy is around 50,000 acres.**
- **Processes that provide useful energy (such as biofuel production) involve capture of only a small fraction of incident solar energy.**
- **The earth must emit energy into space at the same rate that it receives energy from the sun.**

5.1 Introduction

Since fossil fuels will eventually run out, the future of civilization depends on developing and implementing alternative energy sources. The only options are renewable energy sources and nuclear energy. (Uranium for fission reactors is a large but finite resource. If fusion energy becomes a reality, the resource is so great that it is essentially limitless.) All the renewable sources—except geothermal energy and tidal energy—derive their energy from the sun.

This chapter deals with some general features that are common to the various renewable energy sources. The details are also important, and they are addressed in subsequent chapters.

5.2 The Solar Resource

In this section, we consider solar radiation as an energy resource. The sun may provide energy directly, as with solar space heating or water heating, or with electricity production via photovoltaic cells or solar heat engines (Chapter 6 provides details). The sun may also provide energy indirectly as with the production of plant matter through photosynthesis (Chapter 7), the production of wind by uneven heating of the earth (Chapter 8), its contribution to ocean currents by temperature differences and wind (Chapter 9), and through the production of rainwater that descends through hydroelectric plants (Chapter 9).

The average radiation intensity striking the earth's atmosphere is about 108 BTU per hour per square foot. Of this energy flow, about 34 BTU per hour per square foot are reflected back into space, 21 BTU per hour per square foot are absorbed in the atmosphere, and 53 BTU per hour per square foot are absorbed by the earth¹ (see Figure 5-1). This energy absorption rate is the global average and should be fairly representative of temperate zones such as the continental U.S.

Actual energy absorption rates in the continental U.S. vary with latitude and regional climates (such as desert vs. verdant regions). The average absorption in the U.S. varies from about 46 to 75 BTU per hour per square foot². These values are known quite accurately.

Solar energy absorption statistics appear in Table 5-1.

The continental U.S. minimum (lowest incidence) values apply for northern U.S. states, and continental U.S. maximum (highest incidence) values apply for southwestern desert areas, where solar energy incidence is higher and reflection back to space by clouds is small. Appendix G provides a discussion of solar radiation intensities.

It is instructive to determine the number of acres of surface needed to absorb a Quad of energy (10^{15} BTU) per year. The results are shown in Table 5-2.

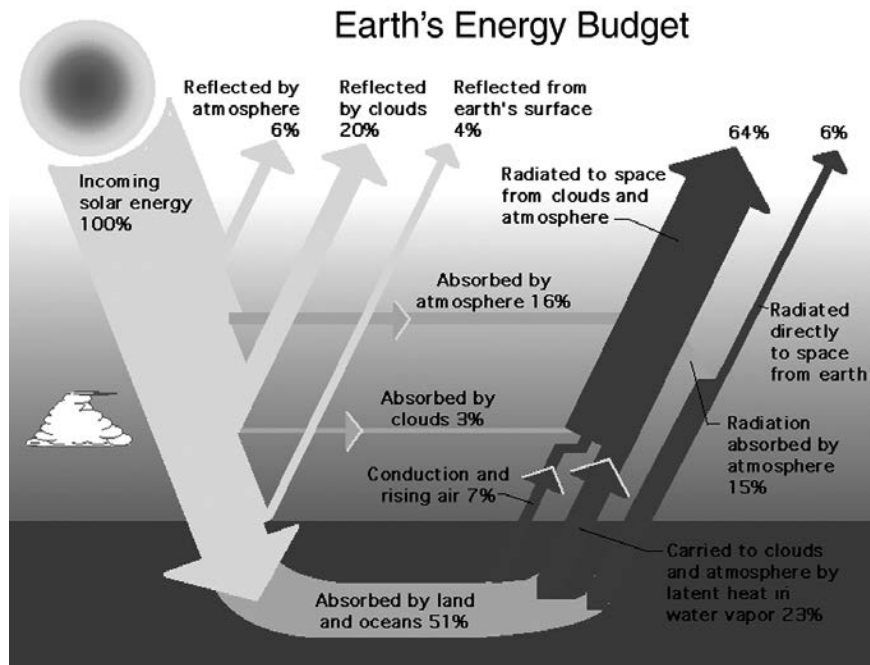

Figure 5-1. Earth's Energy Budget (courtesy of NASA)

Table 5-1. Solar Energy Absorption (Yearly Average)

	Site with Lowest Incidence in the Continental U.S.	Site with Highest Incidence in the Continental U.S.	Global Average
BTU per hour per square foot	46	75	53
BTU per day per square foot	1,100	1,800	1,280
Million BTU per day per acre	48	78	55
Million BTU per year per acre	17,000	28,000	20,000

Source: NASA

Table 5-2. Acreage Required to Absorb a Quad of Solar Energy

Solar Energy Absorption Rate (BTU per day per square foot)	Acres Required to Absorb One Quad per year
1,100 (U.S. minimum location)	57,200
1,800 (U.S. maximum location)	35,000
1,280 (global average)	49,100

(Note: The continental U.S. surface area is about 1.9 billion acres.)

Of course, the earth must emit exactly the same amount of energy that it absorbs to maintain a steady-state condition (constant average temperature). Using the sun's energy for human purposes means diverting a portion of the incoming solar energy stream, putting it to some use, and then returning the diverted energy stream to the earth in the form of heat, which is then radiated by the earth into space.

For example, consider the production of photoelectricity with solar cells. The cells extract energy from the incoming radiation and convert it into electricity. The electricity is then used to produce heat or mechanical work. Since mechanical work ultimately results entirely in heat, all of the photoelectric energy eventually becomes heat, which becomes part of the supply of energy that is radiated by the earth into space. In essence, we borrow energy from the energy stream flowing into the earth system and then return the same amount of energy in the form of earth radiation emissions.

This borrowed energy is dilute, so it must somehow be concentrated to serve human needs.

5.2.1 Solar to Usable Energy Conversions

Solar energy is the primary source for the following energy supplies:

- Direct solar heating and cooling. Solar radiation may be used directly for space heating or cooling and for water heating. (Yes, heat can be used to produce cooling. See Appendix K.)

- Solar electricity. Solar cells convert solar energy into electrical energy directly, and solar heat engines use solar energy to heat a fluid that drives a turbine-generator or Stirling engine.
- Bioenergy. Bioenergy is energy derived from plant matter. Plant matter, or biomass, is produced from water and carbon dioxide by photosynthesis using energy from the sun. The biomass produced can be burned or converted into biofuel, thereby making the bioenergy available for human uses.
- Wind energy. Uneven heating of the earth is the main initiator of atmospheric flows. Some of the wind's kinetic energy can be converted into mechanical work and electricity.
- Hydroenergy. Hydroenergy is energy derived from water motion. The sun evaporates water, some of which condenses and falls as rain at higher elevations. At naturally occurring sites or at dams, the sudden elevation change permits significant energy extraction. Moving water in rivers and in ocean currents possesses kinetic energy. Tides cause back-and-forth and up-and-down water movement. Waves cause up-and-down movement. All of these water movements are potentially useful for producing electricity.

A problem with all these processes that convert solar energy into an energy form that can replace nonrenewable fuels is the low energy density of the input. (There is a huge quantity of solar energy, but it falls on a huge surface.) A full assessment of the potential of renewables as an energy replacement for fossil fuels requires an assessment of the capacity for practical collection and concentration or storage (such as in biomass) of the energy received from the sun.

The transportation sector has the special requirement of energy source portability. Biomass can be converted into liquid or gaseous fuels suitable for use in transportation. Other renewable sources produce electricity, which can provide transportation energy using energy storage in systems such as batteries and gas compression systems or through storage in portable fuels

such as hydrogen that can be produced from water with electricity, from fossil fuels or from biomass.

5.2.2 The Solar Spectrum and Solar Radiation Dispersion

The solar spectrum (wavelength distribution of solar radiation) is important because some processes for producing renewable energy sources depend on the wavelengths of the incident solar radiation. Photosynthesis and photoelectricity production are processes that operate only with certain wavelengths.

Most solar radiation lies within the visible spectrum. The earth, like the sun, is a radiation emitter, but the earth's radiation wavelengths are much longer than the sun's because of the earth's lower temperature (see Figures 5-2 and 5-3). The radiation from the earth extends well into the infrared region. This difference in the wavelengths of incoming solar radiation and outgoing radiation from the earth into space is the basis for the greenhouse effect. The tendency of chemicals in the atmosphere to absorb radiation depends on the wavelength of that radiation. Certain chemicals, when present in the atmosphere, react slightly with short wavelength incoming radiation, but they react strongly with long wavelength outgoing radiation. This interference with outgoing radiation traps the energy in the atmosphere, some of which re-radiates to the surface.

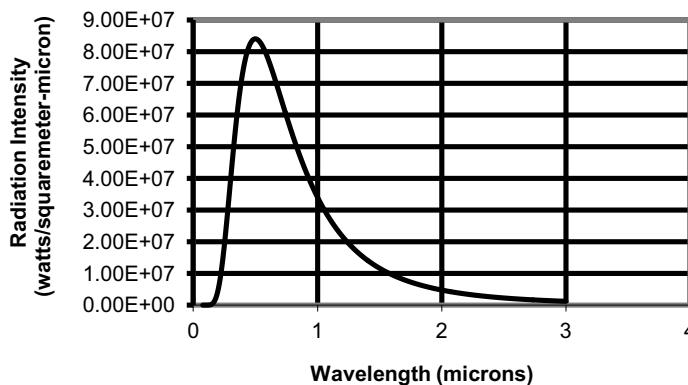

Figure 5-2. The Solar Spectrum

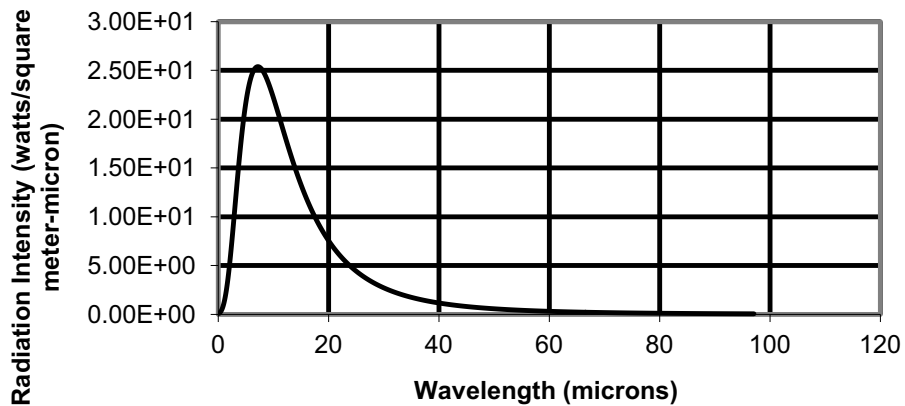

Figure 5-3. Earth's Radiation Spectrum

The radiation incident on the earth includes unscattered radiation and radiation that underwent scattering in the atmosphere. Typically, about 55 percent of absorbed radiation is unscattered, and 45 percent is scattered³. The unscattered radiation emanates from a point in space (the sun), and the scattered radiation emanates from the full atmospheric canopy. The significance of this is unscattered radiation can be focused with mirrors or lenses, and scattered radiation cannot. One important solar energy application requires focusable radiation. Sunlight is focused with lenses or mirrors on a boiler where high temperatures are achieved. This high temperature heat evaporates a liquid, and the vapor drives a turbine-generator.

5.3 Useful Energy Derived from Sunlight

Sunlight provides the energy for direct applications, in which solar energy is used as it is received, and for indirect applications, in which solar energy creates other energy forms that can be stored and then later transformed into useful energy. Direct applications of solar energy include producing electricity with photovoltaic systems or solar heat engines, space or water heating with solar collectors, and cooling with gas absorption refrigeration systems. The indirect applications include producing fuels from biomass, producing electricity with wind turbines, and producing electricity with hydroenergy systems. The stored energy is in the form of chemical energy

for biomass, kinetic energy for wind, and kinetic or potential energy for hydroenergy.

5.4 Useful Energy from Non-Solar Sources

Renewable sources of energy include two that do not derive their energy from sunlight: geothermal energy and tidal energy (which is also a form of hydroenergy).

Geothermal energy is the result of residual heat remaining from the initial formation of the earth and from the radioactive decay of elements located in the interior of the earth. This energy causes the temperature to increase as depth increases. In some locations, the temperature is high enough near the surface to boil water or even melt rock. These shallow energy reservoirs can sometimes be tapped for practical applications such as heating or electricity production. Drilling into the earth can provide access to a much larger resource of stored geothermal energy located at greater depths.

Tidal energy is a form of hydroenergy, but it is placed in this section on non-solar sources because it results from gravitational effects rather than solar radiation. Tides fill estuaries, causing water flows and creating opportunities for impoundment and subsequent release through a turbine.

5.5 Using Renewables

The renewable energy sources discussed above are all of the currently known possibilities for large-scale energy production in the future. Some, possibly all, will become essential features of modern civilization. It is too early to know which ones will dominate or even participate in future energy production. All are currently undergoing major development efforts, and these efforts will surely continue.

The U.S. and all other developed countries have built huge and expensive infrastructures based on energy production with fossil fuels. Switching to

renewables will require investment in new energy production and transport systems and changes in energy use facilities and equipment. The components of the new infrastructure are discussed in later chapters.

References

1. NASA “Earth’s Radiation Budget Facts” at http://science-edu.larc.nasa.gov/EDDOCS/radiation_facts.html.
2. National Renewable Energy Laboratory “Solar Radiation Data Manual for Buildings” at <http://rredc.nrel.gov/solar/pubs/bluebook>.
3. “Fundamentals of Physical Geography” at <http://www.physicalgeography.net>.

Exercises

- 5-1. The diameter of the earth is around 7,926 miles (12,756 km), and the sun is approximately 93,000,000 miles (149,668,992 km) away. What fraction of the sun’s energy strikes the earth’s atmosphere? Estimate the total power output of the sun. (Hint: Consider the target area presented by the earth relative to all of the power flowing through a spherical shell at 93,000,000 miles.)
- 5-2. The albedo is defined as the fraction of incident radiation that is reflected. Use Figure 5-1 to estimate the earth’s albedo.
- 5-3. One of the energy transport mechanisms shown in Figure 5-1 is by latent heat in water vapor. Explain how this process removes heat from the surface and deposits it in the atmosphere.
- 5-4. What would happen to energy absorption by the earth if an increase in particulate matter in the atmosphere caused an increase in reflection of incident solar radiation?

- 5-5. How much power (in BTUs per hour and in kilowatts) is radiated from the earth into outer space without absorption in the atmosphere?

6

Solar Energy

The Main Points

- **Photon absorption heats an absorber, causing it to emit photons (called *re-emitted photons*).**
- **Solar heating involves the use of a collector to capture solar photons and re-emitted photons produced within the collector.**
- **Capture of re-emitted photons in a collector involves the use of a window that transmits solar photons, but absorbs re-emitted photons.**
- **Solar electricity may be produced using photovoltaic systems or solar heat engines.**
- **The photoelectric effect involves release of electrons upon absorption of photons.**
- **Solar heat engines use mirrors or lenses to focus solar photons to provide a high temperature energy source for the engine.**

6.1 Introduction

The solar energy resource described in the previous chapter may be used for heating or cooling applications or for producing electricity. Solar energy is attractive because it is there for the taking. But the use of solar energy requires consideration of two main issues: How much solar energy can be captured in a practical and economical way? How can the intermittency of solar energy be accommodated?

Three appendices (G, H, and I) augment this chapter with detailed information related to the practical application of solar energy. Two other appendices (J and K) contain related information about radiation absorption physics and vapor absorption refrigeration (which can be powered by solar radiation).

6.2 Solar Heating

6.2.1 Principles

Solar collectors for heating applications may be glazed (with a glass or plastic cover) or unglazed. Unglazed systems are used for low-temperature applications and are less efficient and less expensive than glazed systems.

For glazed systems, solar heating involves admitting sunlight through a glass or plastic cover into a closed space, absorbing incident radiation on a blackened collector floor and then absorbing re-emitted photons before they can escape to reach the atmosphere. Glass—and some clear plastics—readily transmit solar photons but absorb re-emitted photons. An enclosed structure with a transparent glass or plastic cover facing the sun and a blackened absorptive surface will capture solar energy. This heats the interior of the structure, and a liquid or gas that passes through the structure can carry the heat away. The use of such energy-trapping devices for applications such as space heating and water heating is growing.

Desirable features of glazed solar collectors are as follows:

- Strong absorption of incident photons that reach the heat deposition site (the black floor of the collector)
- Window with high transparency to incident photons
- Window with low transparency to re-emitted photons
- Insulation on sides and bottom to reduce heat losses
- Efficient heat transfer to a liquid or gas that carries the heat out of the collector

Solar heaters may be “active” or “passive.” Active collector designs use a pump or fan to circulate the heat transfer liquid or gas. Passive systems use

natural circulation (warmer fluid rises, and cooler fluid sinks) for circulation of the heat transfer fluid.

Solar collector designs include flat-plate collectors and evacuated tube collectors. Flat-plate collectors are simply boxes (usually rectangular) with a transparent window on top and a blackened surface on the inside bottom. Tubes along the inside bottom contain a liquid or gas that carries the heat away. Figure 6-1 shows a flat-plate collector. Evacuated-tube collectors use glass tubes from which air has been evacuated and which contain blackened concentric tubes for liquid circulation. The vacuum minimizes heat losses from the tubes to the surrounding air. Figure 6-2 shows a typical evacuated-tube collector.

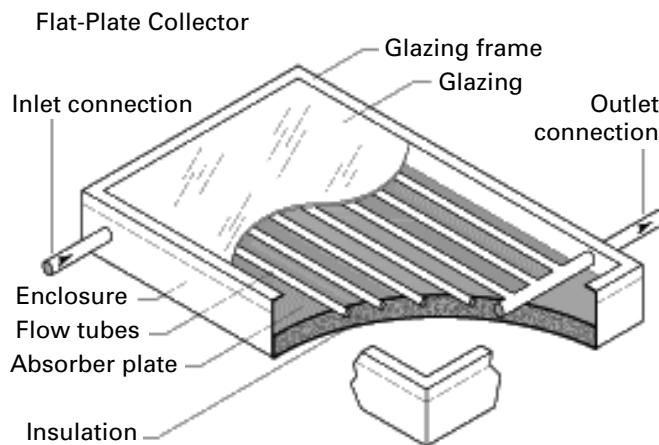

Figure 6-1. A Flat-Plate Solar Collector (courtesy of U.S. Dept. of Energy)

A common installation site is on rooftops, especially for residential applications (see Figure 6-3). A wide array of solar collectors is available from vendors, and many designs are available for do-it-yourself projects.

6.2.2 Residential Applications

Solar heating may be used in residences for water heating, space heating, and pool heating.

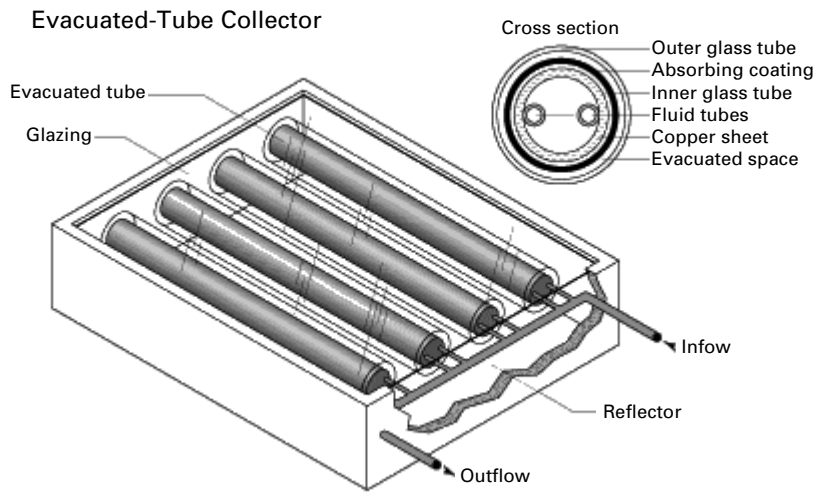

Figure 6-2. An Evacuated-Tube Solar Collector (courtesy of U.S. Dept. of Energy)



Figure 6-3. A Typical Roof-Top Solar Collector (courtesy of U.S. Dept. of Energy)

Water Heating

Water heating system design requirements depend on hot water demand and on local solar radiation intensities. Water heating is needed in all homes, and the need is year-round. A solar water heating system that provides just enough hot water in summer would fall short in winter, and a system that provides just enough hot water in winter would have excess

capacity in summer. The property owner must decide which of these objectives will be the basis for selecting the collector design.

Collectors used for solar water heating systems are generally the glazed type and may be flat-plate collectors or evacuated tube collectors. The collector orientation in winter should be so as to maximize solar energy absorption. Changing the collector orientation in warmer months is needed only if maximizing energy capture in every season is beneficial.

As will be discussed in Chapter 15, the average American home uses about 100 million BTU of energy per year. Water heating accounts for about 17 percent of residential energy use, or 17 million BTU per year per household.

Unlike space heating energy requirements, water heating energy requirements do not depend on climate or the energy use characteristics of the residence such as size, insulation, number of doors and windows, shading, etc. Consequently, it is easier to estimate typical requirements for solar water heating systems than for space heating.

Determining the required size of a solar collector for water heating can be simple (and very approximate) or very detailed. The simplest, rule of thumb procedure provided by The U.S. Department of Energy¹ is as follows:



Rule of Thumb: Provide 20 square feet of collector for each of the first two residents. Add 8 square feet for each additional resident for homes in the Sun Belt and 12 to 14 square feet for each additional resident for homes in the northern U.S.

Detailed estimates for a specific location can be made by solar contractors or with software available to the public on the Internet. A search on “solar collector calculation” will provide numerous free calculation packages. These packages account for local conditions, and some also provide cost estimates.

The essence of collector sizing calculations is outlined in the following example:

Example 6.1

Consider a solar water heater for a home in Knoxville, Tennessee, with a water-heating energy requirement of 17 million BTU per year or 46,600 BTU per day. Figure 6-4 shows the radiation absorption for a two-axis tracking collector (the type that provides the greatest absorption per unit area) and a fixed orientation collector oriented at 50.82 degrees (latitude plus 15 degrees, a good winter orientation). (See Appendix H for details about collector orientation.)

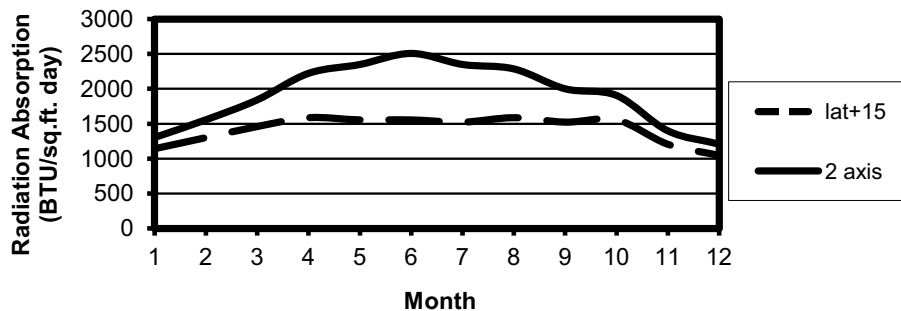

Figure 6-4. Knoxville Solar Radiation Absorption (horizontal collector)

The figure shows the radiation impinging on the fixed-axis collector varies from about 1050 BTU per square foot per day in winter to about 1550 BTU per square foot per day in mid-summer. The yearly average for the fixed-axis collector is about 1,425. For a two-axis tracking collector the range is from 1,200 in winter to 2,500 in summer. Significantly, the wintertime radiation is nearly the same for both types of collector. The yearly average for the two-axis tracking collector is about 1,900.

The figure shows the fixed-axis collector, sized for summer water heating, sees about 67 percent as much radiation in the middle of winter as it does in summer. The yearly average is about 92 percent of the maximum radiation seen by the collector.

For a collection efficiency of 50 percent, a fixed-axis collector sized for summer water heating would need about 60 square feet of surface ($46,600/(1,550 \times 0.5)$). Such a collector would provide 92 percent of annual water heating energy. Sizing the collector to provide 100 percent of annual water heating energy would result in significant excess capacity in the warmer months.

The two-axis collector would require less collector surface, but at the expense of a more complex design.

Note that the rule of thumb gives estimates of 48 square feet in the Sun Belt and 52 to 54 square feet in the northern U.S. for the average U.S. household (three people). Also, one of the on-line water heater energy calculators² gives a panel area requirement of 64.6 square feet for the Knoxville application. Clearly, all three estimation methods give comparable results.

The collector is only one essential part of a solar water heating system. The system must also include plumbing, controls, storage, and, in colder regions, freeze protection. Solar water heaters are usually installed in series with a conventional water heater to ensure a hot water supply on overcast days.

Space Heating

Solar space heating is similar to water heating, but with an important difference. Space heating is needed only in cooler months, but that is when solar radiation is weakest. Collector sizing must account for low winter solar energy availability. A backup heating system is usually provided to compensate for solar energy shortfalls. Backup heat or energy storage is also needed for nighttime heating.

The collectors are generally glazed and may be flat-plate or evacuated tube types.

Space heating is needed when the average outdoor temperature is lower than some level at which heating is needed for comfort. A common cutoff is an average outdoor temperature of 65°F (18°C). The duration of time with average monthly temperatures above 65°F ranges from no months per

year in the northern continental U.S. to 12 months per year in southern Florida.

The average U.S. residence uses about 50 million BTU per year for space heating. However, the need for space heating varies significantly in different regions of the U.S. As will be discussed in Chapter 15, a metric called “heating degree days” is used to indicate relative heating energy requirements. This metric is defined as follows:

$$\text{Heating Degree Days (HDD)} = \text{Sum of (days when the average temperature is below } 65^{\circ}\text{F)} \times (65 \text{ minus the average temperature on that day})$$

Table 6-1 shows data for yearly mean temperature, heating degree days, and months per year with average temperatures above 65°F in several U.S. cities.

Table 6-1. Weather Factors Related to Heating Energy Needs

City	Mean Temperature °F	HDD	Months Above 65°F
Hartford, CT	50.2	6,104	3
Laramie, WY	40.4	9,038	0
Denver, CO	50.1	6,128	3
Knoxville, TN	59.5	3,531	5
Atlanta, GA	62.1	2,827	5
Houston, TX	68.8	1,525	7
Miami, FL	76.7	149	12

Clearly, there is much greater variation in space heating needs than in water heating needs for different locations.

An example demonstrates the calculation of collector surface requirements:

Example 6.2

Consider a home in Knoxville, Tennessee, with an annual heating energy requirement of 50 million BTU. The monthly mean temperatures in Knoxville are shown in Fig-

ure 6-5. Heating is needed for around 200 days (mid-September through May). The average heating requirement is 250,000 BTU per day.

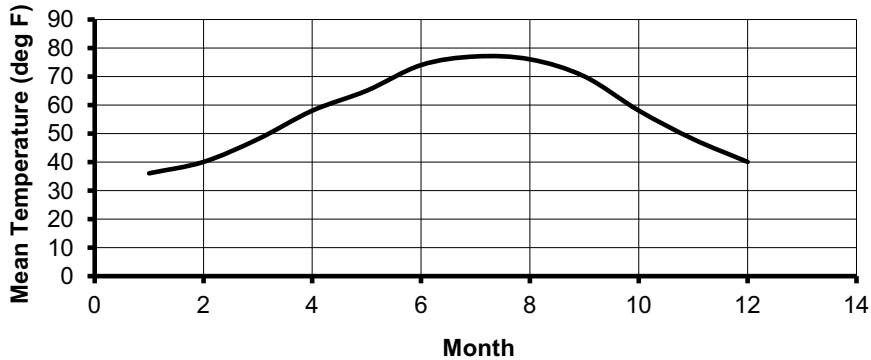

Figure 6-5. Knoxville Mean Temperatures

The pertinent solar radiation data for this example is the same as that used in Example 6.1. Figure 6-4 shows the annual variation of solar radiation seen by a fixed-axis collector oriented at 50.82 degrees and a 2-axis tracking collector in Knoxville. During the heating months, the solar energy seen by the fixed-axis collector ranges from about 1,050 to 1,550 BTU per square foot per day; the energy seen by the two-axis tracking collector ranges from about 1,200 to 2,200.

Space heating energy requirements vary significantly as daily average outside temperatures vary during the colder months. In this example, we can estimate possible ranges of acceptable collector size. For the fixed-axis collector with a collection efficiency of 50 percent, the collector surface required to supply cold-weather average energy needs is 325 to 475 square feet. For the two-axis tracking collector with a collection efficiency of 50 percent, the collector surface needed to supply cold-weather average energy needs is 225 to 415 square feet.

The storage of energy for use when sunlight is unavailable is an important issue in space heating. One option is to store heated water in an insulated water tank (see Section 15.3.4 for details about heat storage systems). A water-to-air heat exchanger would be used to heat the air in living spaces.

The required volume of water in storage depends on the energy needed and the temperature of the stored water, causing the storage volume to depend strongly on local weather and the features of the home being heated. The following example shows the calculation for a hypothetical case.

Example 6.3

Consider a home in which storage capacity is needed for half of the home's energy requirement. Assume the home uses the average annual space heating energy of 50 million BTU and that heating is needed for 200 days per year. Therefore, the storage tank would have to store an average of 125,000 BTU per day. Further assume the water is stored at 120°F, and the desired heated air temperature is 80°F. Since the specific heat capacity of water is 1 BTU per pound per °F, each pound of water delivers 40 BTU when it cools by 40°F. Since the density of water is around 8 pounds per gallon, each gallon of stored water would deliver 320 BTU. The storage volume would be 125,000/320 or around 390 gallons (about 50 cubic feet). This could be accomplished with a tank having a 4-foot diameter and a 4-foot height. Since the heat needed on the coldest days would exceed the average, the storage volume would need to be somewhat larger than 50 cubic feet.

For homes with hot tubs, the hot tub might serve for energy storage if it included proper insulation, plumbing, and controls.

Pool Heating

Heating pool water extends the number of days per year that a swimming pool can be used. Heating may be needed even in summer months in northern continental U.S. sites, but most American pools are in warmer regions where heating is needed only in the spring and fall.

Swimming pools generally have most of the plumbing needed for a solar heater, and the energy storage medium is the pool itself. A typical backyard pool contains about 15,000 gallons of water (about 120,000 pounds). Pool heating has two distinct operating regimes: bringing the temperature up to a comfortable level and maintaining the temperature. Bringing the temperature of cold water up to comfortable levels requires more energy input per day than maintaining water at the desired temperature. Sizing a collector for

maintaining a desired temperature may be too small for heating the water initially, and supplemental heat may be required.

Contractors have collector sizing software, and Internet sources provide sizing estimates for public use. For example, one such website³ gives an estimate of solar collector surface area of 360 square feet for Knoxville. This estimate assumes unshaded pool and collector sites and the use of a pool cover at night. The rule of thumb is that collector area should be 50 to 100 percent of the pool surface area. Using the rule of thumb, a typical 15- by 30-foot pool should have a collector area of 225 to 450 square feet.

Combined Heating Systems

Of course, installed solar heating panels can provide heat for a combination of water heating, space heating, and/or pool heating if the system includes appropriate plumbing and controls. Separate heating systems might include 60 square feet for water heating, 500 square feet for space heating, and 500 square feet for pool heating. But pool heating requirements are smaller when space heating requirements are greatest. Therefore, the same collector could be used for space heating in winter and for pool heating in spring and fall. Such a system would need additional investment in valves and controls.

Solar Cooling

Vapor absorption refrigerators use heat energy to accomplish cooling (see Chapter 15). Solar energy can be used to provide the required heat.

6.2.3 Commercial and Industrial Solar Heating Applications

Commercial and industrial facilities can also use solar heating systems. The principles are the same as for residential systems. Space heating is the most important application for most commercial and industrial consumers. Hotels may select solar heating systems for pool heating. Of course, energy requirements for large buildings are much greater than for homes, requiring much greater collector surface area.

6.3 Solar Electricity

Solar energy may be used to produce electricity in three ways. One is to use solar energy to boil water that then drives a turbine. This requires high temperatures, so producing steam from solar energy usually involves concentrating the energy by using mirrors or lenses to focus energy on a boiler. The second method for producing electricity is the use of photovoltaic devices. Photovoltaics are materials that release electrons when struck by photons. A third method, which is still speculative, would use solar heating to cause air to rise through a tall chimney. The moving air would pass through a turbine that drives an electric generator.

All of the systems for producing solar electricity function only when the sun is shining. Satisfying around-the-clock demands for electricity requires backup systems and/or energy storage (see Section 6.3.4).

6.3.1 Solar Heat Engines

Solar heat engines use solar energy to boil a liquid or heat a gas. Solar heat engines include solar towers, parabolic collectors, and Stirling engines. For solar towers and parabolic collectors, the target contains fluid that is caused to boil by the absorbed energy. The resulting vapor drives a turbine-generator to produce electricity. Stirling engine designs use mirrors to provide the heat source for engine operation. (Appendix D addresses Stirling engine principles.)

The solar tower design uses an array of mirrors located on the surface around a boiler mounted on a tower. Figure 6-6 shows a solar tower. The parabolic collector design uses concave mirrors that reflect solar photons onto a tube in which a fluid is heated and boiled. Vapor from an array of tubes is collected and used to drive a turbine-generator. Figure 6-7 shows a typical design.

As discussed in Chapter 2, vapor emerging from a turbine must be condensed in order to maintain a pressure difference across the turbine as needed to maintain flow. Thus, solar towers and parabolic collector systems

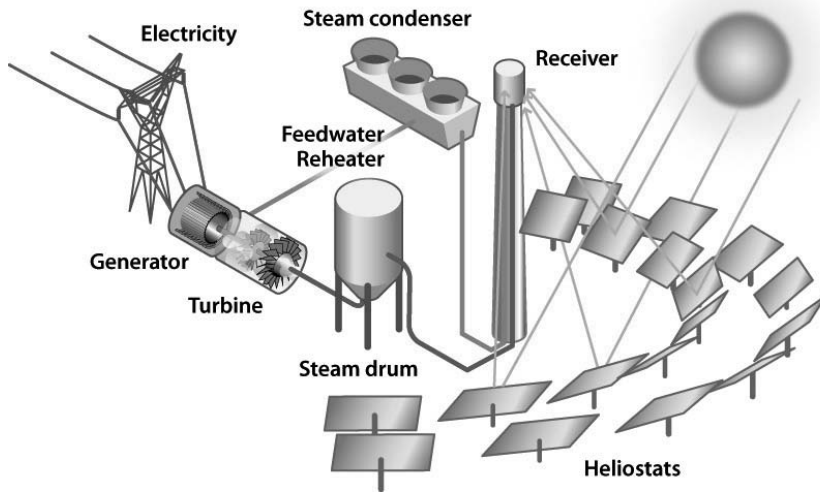

Figure 6-6. A Solar Tower (courtesy of U.S. Dept. of Energy)

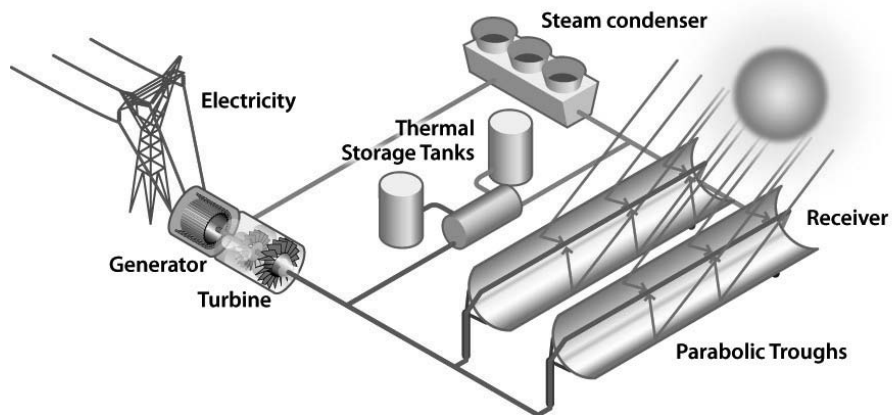

Figure 6-7. A Parabolic Solar Collector (courtesy of U.S. Dept. of Energy)

require a means to cool the turbine exhaust so as to cause condensation. Stirling engines also require cooling as described in Appendix D. In a typical power plant, the energy transferred to the surroundings is $2\frac{1}{2}$ to 3 times the electrical energy produced.

The best (and almost universally used) heat sink is water. The heat removal capability of cooling water may be increased if some of it is allowed to evaporate, as in a cooling tower. In any case, solar heat engines require access to a large heat sink, usually water. Where water is unavailable or scarce, dry cooling (heat transfer to ambient air) may be used. However, dry cooling is significantly less efficient and more expensive than water cooling. Water unavailability may limit deployment of solar heat engines in desert areas, where land and solar insolation exist in abundance.

Since sunlight must be focused in solar heat engine applications, the light must emanate from a point. In passing through the atmosphere, some light reaches the surface without scattering, and some undergoes scattering. The unscattered light can be focused, and the scattered light cannot. About 51 percent of surface energy absorption is due to unscattered sunlight. The net efficiency of conversion of solar energy into electricity by heat engines is the product of the unscattered radiation fraction (51 percent) and the thermodynamic efficiency (30 percent) of the engine, giving an overall efficiency of about 15 percent. Typical solar heat engines would require around 330,000 acres per Quad of electricity generated.

6.3.2 Photovoltaics

Photovoltaic systems are in wide use for specialized applications. They are practical for low power applications, such as watches and calculators, and are widely used. They are also used in certain other, larger-scale, off-grid applications. Photovoltaics are used extensively in satellites and space stations where other energy supplies are unavailable or impractical. Modest energy needs in remote regions of underdeveloped countries can sometimes be met with photovoltaics at lower cost than building power lines. Photovoltaic systems are also being deployed in large scale central station power plants. Major growth in the construction of large solar “farms” is expected as production costs of the devices decrease due to advances in technology and to mass production.

Photovoltaic Principles

The basic idea in photoelectricity is transferring the energy of a solar photon to an electron in a substance, thereby creating a free electron and leaving behind a vacant space (a so-called “hole”). Devices composed of appropriate pairs of materials, called semiconductors, create a diode, a device that allows the flow of electrons in one direction and blocks flow in the opposite direction. If the two sides of the device are connected by a conductor, electrons ejected by solar photons will flow through the conductor, providing an electrical current that can be put to use. A more detailed description of photoelectricity appears in Appendix I.

Photovoltaic devices are currently capable of converting about 15 percent of incident solar energy into electrical energy. Improvements to as much as 30 percent are anticipated.

Photovoltaic Materials and Systems

Most photovoltaic devices are made of silicon, with small amounts of additives called *dopants*. Common dopants are phosphorous and boron. A junction is created by positioning silicon containing one dopant in contact with silicon containing the other dopant. The device is constructed as an array of thin doped silicon wafers. Figure 6-8 shows a typical device.

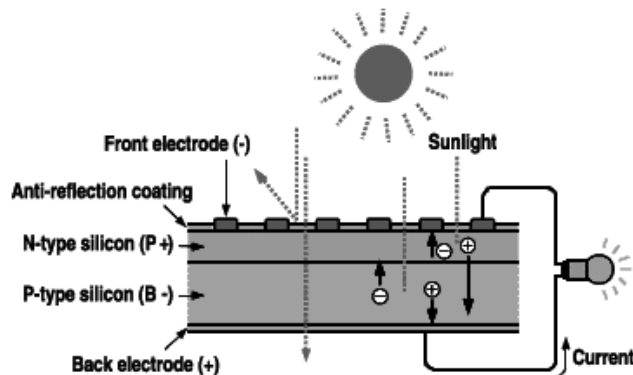

Figure 6-8. A Photovoltaic Cell
(courtesy of National Renewable Energy Laboratory)

A newer type of photovoltaic material is the thin film type, which uses an organic polymer. These materials permit added flexibility in solar photovoltaic system design.

Local Electricity Production

Photovoltaic systems may be used to provide electricity locally to residences and businesses. These systems include a photovoltaic panel and an inverter, a device that converts the direct current produced by the photovoltaic panel into the alternating current needed by most electrical devices used in homes and businesses.

In some locations, local producers can sell excess electricity to the region's utility.

Websites provide free calculation packages for use by the general public for estimating photovoltaic system performance. One such package is the "PV Watts" software provided by the National Renewable Energy Laboratory⁴.

Photovoltaic Status and Potential

The cost of photovoltaic systems is falling, but they are still uncompetitive for large-scale electricity production systems as this book is being written. The competitiveness of solar photovoltaic electricity depends on three main factors:

- The initial cost of the photovoltaic system
- The interest rate on the capital expenditure (almost all of the cost of photovoltaic electricity is for debt service)
- The cost of electricity from competing conventional producers

As photovoltaic systems reach cost parity with other systems, it is expected that the number of local electricity production systems in homes and businesses and large photovoltaic farms will increase significantly.

It is noteworthy that photovoltaic systems do not require cooling, and, therefore, desert areas can potentially host large installations.

For photovoltaics that operate at 15 percent efficiency, about 330,000 acres of land area would be required per Quad of electricity (about the same as the land required for solar heat engines). If the anticipated improvement to 30 percent occurs, the land requirement drops to 165,000 acres. For comparison, the state of Arizona covers 73 million acres.

6.3.3 Solar Chimneys

A third type of system for producing solar electricity has been proposed. In this approach, a large area covered by plastic sheeting surrounds a tall, hollow tower. The air under the sheeting experiences solar heating. The heated air rises through the tower. Turbines in the air flow path at the base of the tower drive electrical generators. This approach is very simple in principle, but large commercial systems have not appeared due to technical immaturity and the need for the large (and expensive) systems that are believed necessary for achieving competitiveness.

6.3.4 Dealing with Intermittency

Since operating costs for solar electricity production are negligible, there is an incentive to use all that can be produced in solar power plants. This means other power plants must increase or decrease production as solar power production decreases or increases. Solar power production is naturally intermittent. It varies with the time of day and with the extent of cloud cover. Using all of the solar electricity as it is produced is suitable as long as solar power production is small enough to place acceptable power production demands on other plants that are assigned load-following duty. These load-following plants must change production continuously to compensate for changes in solar electricity production. When solar power generation capacity grows, it places increasing demands for frequent changes in generation on the load-following plants, causing wear and tear and sub-optimal operation. At some point, the demands become excessive. When this happens, it becomes desirable to store some or all of the energy from solar plants and release the stored energy as needed. Batteries and capacitors are capable of storing energy.

Solar heat engines can reduce problems due to intermittency by storing heat energy. Excess energy from the collector is used to heat a medium such as molten salt. The hot medium subsequently transfers its energy to the working fluid, which then is used to produce electricity when sunlight is unavailable. Since there is no transformation of one form of energy into another in storing or recapturing energy (both are heat energy), this method of storing energy is quite efficient.

Photovoltaic systems produce electricity directly, and electricity cannot be stored except in capacitors. Other possible storage methods such as pumped storage (see Section 9.5), battery storage, or hydrogen production involve transforming energy from one form to another in storage operations and in recovery operations. Since there is always energy loss in these transformations, the recoverable energy is less than the electricity initially produced photovoltaically.

Regardless of the storage method used, there is a cost penalty because of the added equipment and the lost energy.

Small photovoltaic systems in homes or businesses can deal with intermittency by sharing production with grid sources. During the day, photovoltaic production occurs, and the demands for grid electricity are greatest. If the local photovoltaic system produces more electricity than the local requirement during the day, excess electricity can be fed into the grid. At night, when the local producer is idle, the grid can feed electricity into the home or business. In this way, the home or business sells electricity when possible and buys electricity when needed. This benefits the home or business and reduces peak production generation requirements for the utility.

6.4 Looking Ahead

Solar energy has the potential to become a major part of America's energy supply in the future. Current research is increasing efficiency and reducing unit costs. But much remains to be done. Manufacturing and installing solar systems that are competitive with traditional energy sources is a major

challenge. Even assuming that costs become competitive soon, it will take many years to manufacture and install enough systems to contribute significantly. Associated infrastructure changes must also be built to accommodate intermittency and the remoteness of desirable sites for energy farms.

Solar energy proponents are appropriately enthusiastic about its potential for producing ample, cheap, clean energy. But building a large-scale solar energy system will require time, money, and commitment.

References

1. U.S. Department of Energy Report “Heat Your Water With The Sun” at <http://www1.eere.energy.gov/solar/pdfs/34279.pdf>.
2. Energy Matters “My Solar Estimator” at <http://estimator.solar-estimate.org>.
3. The Solar Direct Company “VORTEX Solar Pool Heating Automated System Sizing” at http://www.solardirect.com/pool_heaters/solar_pool_heating/calculator.htm.
4. National Renewable Energy Laboratory “PV Watts” calculator at <http://www.nrel.gov/rredc/pvwatts>.

Exercises

- 6-1. Find the average solar energy absorption rate in January for a horizontal surface in your location. Assume the energy required to heat water is 50,000 BTU per day. How many square feet of horizontal surface would be needed in a solar water heater that operates at 50 percent efficiency? What would happen to the surface area requirement if the collector were tilted?
- 6-2. How much energy (BTUs and kilowatt hours) would be captured by a collector in Knoxville with 40 percent efficiency in January by a two-axis tracking collector with two hundred square feet of surface?

- 6-3. Estimate the ratio of heating energy requirements in Laramie to the required heating energy requirements in Atlanta.
- 6-4. Compare the January solar energy available in Laramie and Atlanta.
- 6-5. Discuss the implication of the results from Exercises 6.3 and 6.4.
- 6-6. A homeowner decides to insulate his hot tub and use it for storing solar energy collected during daylight hours in winter. The tub holds 150 cubic feet of water. How much energy (BTUs and kilowatt hours) is stored per day if the daytime solar heat raises the water temperature to 100°F (38°C) and the water cools to 80°F (27°C) at night when used to warm the home?
- 6-7. Tilting solar collectors reduces the area of the collector, relative to a horizontal collector, that is needed to absorb equal amounts of solar energy, but does not change the horizontal footprint of the collector system. Explain.
- 6-8. Estimate the cost of heating a 15,000 gallon swimming pool from 60°F to 80°F (16°C to 27°C) with electric heaters (assuming zero heat loss during heating) if electricity costs 11 cents per kilowatt-hour.

7

Biofuels

The Main Points

- Terrestrial plants convert 1 to 2 percent of incident solar energy into chemical energy by photosynthesis.
- Terrestrial plant yields and energy content per unit weight vary over a small range.
- The energy used to grow biomass and to process biomass into biofuel reduces the net energy available in biofuel.
- Replacing 100 percent of current oil use with biofuel from terrestrial plants is impossible because of the amount of land required to grow sufficient biomass.
- Algal biofuel can be produced photosynthetically or by fermentation of biomass.
- Chemical, biochemical, and thermochemical processes exist for converting biomass into biofuel.
- Ethanol can be produced from cellulose, hemicellulose, and lignin, as well as from starch.
- Ethanol is the main focus of current biofuel development efforts, but other biofuel production technologies are potentially superior.

7.1 Introduction

The production of fuels from biomass usually involves disassembling the molecules comprising plant matter and producing new molecules from the contained carbon, hydrogen, and (in the case of some biofuels) oxygen. (The exception is the direct use of oils from some plants as fuel.) The most desirable transformation would be one that yields hydrocarbons with two to

four hydrogen atoms per carbon atom. These products could serve as a direct replacement for oil and natural gas. The preferred transformation would involve enzymes so as to achieve simplicity and low cost. Scientists are actively seeking new enzymes for achieving this goal.

Biofuels that can be made by processing plant materials include alcohols, hydrocarbons, esters, and ethers. Three broad categories of processes are used to accomplish the transformations: biochemical processes, thermochemical processes, and chemical processes.

Biochemical processes are those that use living organisms to enable and/or facilitate reactions. Thermochemical processes use high temperature to decompose biomass molecules. Chemical processes are those with reactions between compounds that include neither a biochemical nor a thermochemical involvement. In addition, hybrid processes involve a combination of process types.

This chapter addresses the main currently-known technologies for producing useful biofuels in each of these process categories.

7.2 Plants and Energy

Plants use sunlight for the energy needed to combine water and carbon dioxide to produce carbohydrates. Only a small fraction of the solar energy striking a plant's leaves is captured and used for photosynthesis. Energy capture efficiencies for terrestrial plants are typically around 1 to 2 percent¹.

Plant matter releases energy when it oxidizes and converts back into water and carbon dioxide. The energy released in oxidation is equal to the solar energy absorbed initially during photosynthesis. The plant matter that exists between the time that it is formed by photosynthesis and the time that it is eventually oxidized may be viewed as a storehouse of energy. The stored energy can be used directly by burning, or indirectly by converting the material into other chemicals before oxidation. In either case, the maximum

energy available is the solar energy that was originally absorbed by the plant in photosynthesis.

The energy contained in biofuel per acre of land used to grow terrestrial biomass is given by the product of three factors:

- The biomass energy contained per ton of dry biomass
- The tons of dry biomass that can be produced per acre
- The fraction of the contained biomass energy that appears in the biofuel produced

Biomass materials have a wide range of properties, but the energy contained is quite uniform (12.9 to 16.4 million BTU per dry ton)². The crop yields for terrestrial plants are currently 5 to 8 dry tons per acre. Some analysts predict crop yield increases for some plants to 12 dry tons per acre by the middle of the twenty-first century.

The most uncertain factors in projecting the number of acres required for biofuels are future crop yields and conversion efficiencies. Crop yields are determined by plant genetics, sunlight availability, water availability, carbon dioxide concentration in the air, soil nutrient concentration (mainly nitrogen, but including other elements), and soil physical characteristics (sand, clay, rock, etc.).

Table 7-1 shows the land requirements for a range of assumptions for these factors. The specific energy content of biomass used in the calculations for Table 7-1 was taken to be 14.5 million BTU per ton. This is roughly the mid-point of the range of reported values (12.9 to 16.4 million BTU per ton). Values of biomass-to-biofuel conversion efficiency selected for the table are 0.3 and 0.6 (the range of efficiencies potentially achievable) so as to bracket future possibilities. The table shows estimated land requirements to produce 1 Quad and 27 Quads (the current annual U.S. energy production for transportation from crude oil).

The results in Table 7-1 show the land required for replacing the oil used for transportation (27 Quads) with biofuel is large compared to total U.S. land area (1.9 billion acres for the continental U.S.). For example, even the most optimistic assumption results in an acreage requirement of 260 million acres to replace oil for transportation at its current rate of use. This acreage is 59% of total current cropland area (around 441 million acres) and is too great to be feasible. It is clear that devoting this much land to growing biomass for biofuel or even just to harvesting waste biomass is unfeasible.

Table 7-1. Land Requirements for Biofuel Production

Biomass Yield (dry tons per acre)	Biomass to Biofuel Conversion Efficiency	Biomass Energy Productivity (million BTUs per acre)	Land to Produce 1 Quad (million acres)	Land to Produce 27 Quads (million acres)
5	0.3	22	45	1,220
8	0.3	35	29	780
12	0.3	52	19	520
5	0.6	44	23	610
8	0.6	70	15	390
12	0.6	104	10	260

Biofuel production from terrestrial plants could be important in reducing import expenditures and dependence on foreign sources, for producing domestic jobs, and for conserving oil resources, but it clearly is incapable of totally replacing current U.S. oil consumption because of the huge land area that would be needed.

As we will see in Section 7.4.4, algae grow much faster than terrestrial plants. Furthermore, some algae provide high yields of hydrogen, triglycerides, or hydrocarbons. Consequently, there is now great interest in developing practical processes to produce biofuel from algae.

7.3 Plant Characteristics

Plant characteristics determine the possibilities for processing into useful biofuels. The components in plant matter that comprise the raw material for biofuel production are carbohydrates, lignin, and plant oils (see Section 2.10).

Carbohydrates are compounds composed entirely of carbon, hydrogen, and oxygen. Sugars, starches, cellulose, and hemicellulose are all carbohydrates.

The basic building block of all carbohydrates is the sugar molecule. Simple sugars involved in carbohydrate synthesis, called *monosaccharides*, contain either five or six carbon atoms arranged in a ring structure. Five-carbon sugars are called *pentoses*, and six-carbon sugars are called *hexoses*. The monosaccharides contain two hydrogen atoms and one oxygen atom for every carbon atom. Therefore, the formula for pentose is $C_5H_{10}O_5$, and the formula for hexose is $C_6H_{12}O_6$.

Larger carbohydrate molecules (starch, cellulose, and hemicellulose) are formed by linking sugar molecules. Carbohydrates with two linked sugars are called *disaccharides*, and those with more than two linked sugars are called *polysaccharides*. Consider the linking of two hexose sugars to make a disaccharide. The linkage requires the elimination of one water molecule (H_2O). The formula for the resulting disaccharide is $C_{12}H_{22}O_{11}$. The process may be represented as follows:

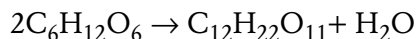

The removal of water is called *dehydration*.

In some biomass-to-biofuel processes, it is necessary to convert polysaccharides into monosaccharides before further processing. Since converting polysaccharides into monosaccharides involves reacting water with the polysaccharide, the process is called hydrolysis.

Starch is a polysaccharide composed of hexose sugar links. Cellulose is also a polysaccharide of hexose sugars, but the structural arrangement of the atoms differs from the structure in starch. Basically, the starch and cellulose molecules are chains of ring-shaped links. In the starch molecule, all the rings face the same way. In the cellulose molecule, each link faces the opposite way relative to adjacent links. (Visualize a chain of connected dinner plates. In starch, each plate faces “up,” and in cellulose, plates alternate facing “up” and “down.”) The structural difference accounts for the different properties of starch and cellulose. It should be noted that any process that breaks the chain in starch or cellulose molecules yields the same simple sugar molecule and provides the same opportunity for further processing by processes such as fermentation into ethanol. Hemicellulose is a polysaccharide composed of linked pentose and hexose sugars.

Plant stems, stalks, trunks, branches, and leaves all contain cellulose and hemicellulose. These plant components are inedible by humans, but some animals and insects can digest them. The cellulose and hemicelluloses in plants are encased in a tough, fibrous material called *lignin*. Lignin is not a carbohydrate, but it is a complex organic polymer.

Some plants also produce oils. Section 7.6.2 and Appendix L present information about vegetable oil properties and processing.

7.4 Biochemical Processes

Five important biofuels may be produced biochemically. These are ethanol, butanol, hydrogen, hydrocarbons, and methane.

7.4.1 Ethanol

Ethanol is a liquid biofuel that can serve as a replacement for gasoline (see Appendix M). It is a clear liquid at normal temperatures, it is less dense than water, it mixes readily with water and with gasoline, and its energy content per pound is about two-thirds that of gasoline. The chemical formula for ethanol is C_2H_5OH .

The biochemical route to bioethanol involves three steps:

1. Enzymatic conversion of carbohydrates into monosaccharides (hydrolysis)
2. Enzymatic conversion of the resulting monosaccharides into ethanol (fermentation)
3. Separation of ethanol from the water used in the process

The technology for producing monosaccharides from biomass depends on the type of carbohydrate being processed. Starch processing may be accomplished with common and inexpensive enzymes. Enzymes for hydrolyzing cellulose and hemicelluloses are known, but suitable inexpensive strains are not yet available. Current genetic engineering work on developing new strains of enzymes for hydrolyzing cellulose and hemicellulose is expected to provide the required biochemical capability. In the meantime, known processes that use acid to hydrolyze cellulose and hemicellulose can be employed. The conversion of cellulose and hemicellulose using the acid process is actually part of a hybrid biochemical-chemical process (see Section 7.7).

The enzymatic conversion of monosaccharides into ethanol is called *fermentation*. Fermentation is an old, well-known technology.

The third step involves removing water from the ethanol-water mixture in a two-step process. Distillation removes most of the water. The remaining water is removed by dewatering with materials that selectively absorb water.

Initial efforts at large-scale production of bioethanol for use as a fuel focus on using the starch in corn. Using corn has some serious drawbacks, mainly competition for its use as food for humans and animals. Consequently, there is intense effort underway to develop economical processes for converting plentiful cellulose and hemicellulose into bioethanol. Appendix M provides more detailed information on bioethanol production, its potential

as a significant replacement for oil, and the practicality of its production and use.

7.4.2 Butanol

Butanol is less well-known than ethanol, but it shows promise for use as a biofuel. It is a clear liquid at normal temperatures; its density is less than that of water but is greater than that of ethanol; it is immiscible with water; and its energy content is about 86 percent of that for gasoline. Butanol is a four-carbon alcohol whose formula is C_4H_9OH .

A biochemical process for producing butanol operates in two stages, with a different enzyme for each stage. The first stage enzyme causes conversion of biomass into butyric acid ($C_4H_8O_2$) and hydrogen. In the second stage, another enzyme converts butyric acid into butanol. This process does not involve the hydrolysis of starch, cellulose, or hemicellulose into simple sugars. It can use the lignin as well as the carbohydrate components of biomass. The two-stage process produces butanol and hydrogen, both useful in energy production. Additional details appear in Appendix N.

7.4.3 Methane

Methane is a colorless, odorless gas at normal temperatures. It exists in natural gas from underground formations; it may be produced from other hydrocarbons; and it may be produced by the anaerobic digestion of biomass.

The decomposition of dead biomass (animal and vegetable) is accomplished by microbes. If the dead biomass is exposed to air, aerobic microbes digest the material and produce carbon dioxide and water. If the dead biomass is isolated from air by overburden or water, anaerobic microbes digest the material and produce mostly methane and carbon dioxide. This gas is called *biogas*. Biogas production occurs in natural settings such as forests and wetlands and in man-made landfills. Some landfills have been fitted with biogas extraction systems, thereby gaining valuable fuel and preventing methane, a powerful greenhouse gas, from entering the atmosphere.

Additional information appears in Appendix O.

7.4.4 Algal Processes

Some work has been done on growing algae for biofuel feedstock. Algae are aquatic plants, and they require sources of carbon, hydrogen, oxygen, and energy for growth.

In photosynthetic algal growth, the source chemicals are carbon dioxide and water, and the energy comes from sunlight. Algae can also grow without sunlight. Certain algae can obtain all of the essential carbon, hydrogen, oxygen, and energy from biomass fed to the reactor. Therefore, they can grow in the dark and are called “dark process” algae. Sugars derived from the biomass provide the energy needed for the biochemical reactions.

The photosynthetic process results in the production of new algal biomass, and the dark process results in the fermentation of biomass (typically terrestrial biomass) into algal biomass with suitable properties for biofuel applications.

The energy contained in photosynthetic algae cannot exceed the energy captured from the sun. The energy contained in dark process algae cannot exceed the energy contained in the biomass used in producing the algae. As expected, the capture of solar energy always limits the energy content of biofuels.

Certain algae can produce hydrogen, triglycerides, or hydrocarbons. These are a potential source of large quantities of fuels to replace traditional fossil fuels. Major research efforts focus on genetic engineering to produce strains of algae that maximize the production of useful biofuels.

Algae grow much faster than terrestrial plants. The naturally high growth rates of photosynthetic algae can be increased in an environment that is rich in carbon dioxide. Designs have been formulated that feed carbon dioxide into algal growth chambers³. Industrial processes with large carbon dioxide production (such as fossil-fueled power plants, ethanol fermenta-

tion facilities, and breweries) could provide the carbon dioxide needed to increase algae growth rates. Commercializing this approach would require locating the algae farm and the carbon dioxide producer close to one another, and the yields would have to be high enough to justify the investment in growth chambers.

Initial prototype systems have demonstrated the dark process route to biofuel production. This work shows the capability of this process to yield a range of useful chemicals, including biodiesel and jet aircraft fuel. Since sunlight is not needed in the dark process, there is no shading by peripheral material, and the reaction proceeds throughout the reaction vessel. On the other hand, in the production of photosynthetic algae, growth occurs only on the surface where sunlight is available.

The photosynthetic process and the dark process described above can produce useful biofuels. These processes are still in the developmental stage, but they show promise for providing significant quantities of useful biofuels. However, it remains to be seen whether the rate of production will be great enough to justify the investment in special facilities required to produce the algal biomass.

7.5 Thermochemical Processes

7.5.1 Introduction

Thermochemical processes used for producing biofuels are those that use heat to convert solid carbonaceous materials into gases and/or liquids⁴. Thermochemical processes are designated as gasification processes or pyrolysis processes. Gasification processes are those that occur with limited oxygen present. Pyrolysis processes are those that occur with no oxygen present. Gasification and pyrolysis processes are typically part of multi-stage processes in which gasification is the first step. Subsequent processing, usually involving a chemical process, yields the desired biofuel.

7.5.2 Gasification

The gasification of biomass produces a synthetic gas called syngas. (See Section 4.7.) Syngas is a mixture composed mostly of hydrogen and carbon monoxide. Currently, most syngas is made from methane, but interest in switching from fossil fuels to renewable fuels has created motivation for addressing syngas production from biomass. Since syngas made from biomass is identical with syngas made from fossil fuels, all of the processes using syngas in the production of other fuels (as discussed in Chapter 4) are also applicable to syngas made from biomass.

Syngas is a fuel and also is a suitable intermediate in producing an array of other fuels by chemical transformations. Some potentially important transformations were outlined in Section 4.7.

7.5.3 Pyrolysis

The pyrolysis of biomass involves heating it in the absence of oxygen to break down the molecules comprising the biomass and to yield new compounds. Any biomass can be pyrolyzed. The specific mix of products obtained depends on the biomass used and the pyrolysis conditions. Pyrolysis yields char (solid carbon) and various gases. The proportions of char and gases depend on the residence time in the pyrolysis reactor. Short residence times favor gas production over char production. This is called fast pyrolysis. Fast pyrolysis followed by rapid cooling of the resulting gases yields bio-oil (also called pyrolysis oil), a liquid that may be used directly as fuel oil or may be further processed to yield other liquid fuels.

Bio-oil is a mixture of compounds that range in color from green or dark red to black. It has a high heating value (HHV) ranging from about 75,000 to 82,000 BTU per gallon. Bio-oil can be used mixed with or as a replacement for conventional heating oil. It can be transported and handled in the same fashion as heating oil, but it degrades with time, requiring limited storage duration.

Bio-oil processing to yield more desirable liquid fuels is in the developmental stage. The purpose is generally to reduce or eliminate oxygen and to produce hydrocarbons with a hydrogen-to-carbon ratio of about two. The adaptation of processes used in petroleum refineries is one of the goals of bio-oil researchers⁵.

Bio-oil production is viewed as a valuable waste disposal technology as well as a bioenergy source. Municipal wastes, farm wastes, food processing wastes, and medical wastes are sources of human pathogens. Pyrolysis of these waste streams can eliminate health hazards while providing bioenergy.

7.6 Chemical Processes and Applications

7.6.1 Introduction

Chemical processes are defined here as those processes that alter chemical compositions without biochemical or thermochemical involvement. The yields of chemical processes often depend on pH, catalysts, pressure, and temperature (though high temperatures are not used to decompose source chemicals as in thermochemical processing).

7.6.2 Lipids

Lipids include vegetable oils and animal fats. Some lipids may be used directly as fuel. For other lipids, it is necessary or desirable to modify them to obtain fuel with desired properties.

The chemical form of a plant's energy reservoir is starch or oil. Animals store energy in the form of fat. Vegetable oil and animal fat consist of organic molecules called *triglycerides*, members of the chemical family called *esters*. Triglycerides are molecules with three chain-like components connected to a spine (see Appendix L). The spine is an alcohol called *glycerol*, $C_3H_5(OH)_3$. The chain-like components are fatty acids, basically hydrocarbons with a carboxyl group at one end. A carboxyl group is a section containing one carbon atom, one oxygen atom, and one hydrogen atom.

Triglycerides may be saturated or unsaturated. A saturated triglyceride has the maximum number of hydrogen atoms per carbon atom that is chemically possible. An unsaturated triglyceride has less than the maximum number of hydrogen atoms per carbon atom than is chemically possible. Most animal fats are saturated and are solid at room temperature, while most vegetable oils are unsaturated and are liquid at room temperature.

Vegetable oils may be used as a fuel without modification. Unmodified vegetable oil fuel is usually called straight vegetable oil or SVO. Vegetable oils and animal fats may also be modified to provide new compounds with properties that overcome some of the practical problems with the use of SVO (mainly high viscosity and thickening or solidification at low temperature). Modified triglycerides are usually referred to as biodiesel fuels even though straight vegetable oil is also a biofuel that can also be used in diesel engines.

The modification of triglycerides requires breaking the chemical bond between the spine and the fatty acid chains to yield smaller molecules composed mostly of hydrogen and carbon. This modification may be accomplished by any of three processes: basic transesterification, acid transesterification, and hydroprocessing. Appendix L describes these processes.

Many plants produce vegetable oils. Unlike the large quantities of crop residues and forest residues available for producing cellulosic ethanol, biomass for vegetable oil production requires dedicated cropland to grow oil-bearing plants. The main oil-bearing crop in the U.S. is soy, but the energy content of soy beans is much lower than that of some other crops, especially those grown in tropical regions such as jatropha and palm. Vegetable oil crops in the U.S. yield 20 to 100 gallons of biodiesel per acre.

It is also possible to harvest vegetable oil from algae grown in an aqueous environment. As has been mentioned, algae naturally grow faster than terrestrial plants, and this rate can be increased in engineered environments where CO₂ and/or nutrients are supplied. Yields of algal oil are much greater than yields of vegetable oil from terrestrial plants.

Animal fats are obtained as waste from food production. They are a suitable source material for producing biofuels, but the quantity of available animal fats is much smaller than the potential quantities of vegetable oil.

The energy content of vegetable oil diesel is about 125,000 BTU per gallon (about 10 percent less than petroleum-based diesel). Consequently, the energy yield for soy oil is 2.5 to 12.5 million BTU per acre. For example, a plant energy yield of 10 million BTU per acre corresponds to a land requirement of 100 million acres to produce plants containing 1 Quad of energy.

Using SVO as a diesel fuel imposes some constraints on the engine and on fuel storage in the vehicle. Standard diesel engines must be modified to use SVO. Special kits are available for the required modification. SVO thickens or solidifies at low temperature, making it unusable without a means to heat it. One approach is a two-tank system in which petroleum-based diesel fuel is used for starting. Engine heat is used to raise the temperature of the SVO, then the fuel tank for engine operation is switched to SVO. SVO may also react with gaskets and seals made of certain materials. Exhaust gases from SVO-fueled vehicles pollute less than those from vehicles fueled with petroleum-based fuel except for a slight increase in oxides of nitrogen. SVO is biodegradable, so spills are less of a problem than for petroleum-based diesel fuel.

To put the potential biodiesel contribution to U.S. energy requirements into perspective, replacing all of U.S. use of petroleum for transportation with vegetable oil biodiesel from soy would require almost 3 billion acres of cropland. Remember that the entire land area for the lower 48 states is 1.9 billion acres. Contributions from animal fats would increase the biodiesel supply slightly, but it is clear that although biodiesel from terrestrial plants may be an important potential energy resource for the future, its contribution can only be a small fraction of current U.S. consumption.

Algal biofuels may become important energy sources, but the most promising production methods require construction of special growth chambers. Achieving significant production will require a major investment in facilities.

Biodiesel may be used alone or in combination with petroleum-based diesel fuel. Mixed fuels carry the designation “B” followed by a number. B designates biodiesel, and the number indicates the percentage of biodiesel in the mixture.

7.6.3 2,5-Dimethylfuran

Another biomass-derived compound that has potential for serving as a biofuel is 2,5-dimethylfuran (DMF). DMF can be produced from biomass, though practical commercial production has not been demonstrated. Recent research⁶ shows that DMF, whose chemical formula is C_6H_8O , has properties that make it attractive as a biofuel. The heating value of DMF is about 40 percent greater than that of ethanol; it is insoluble in water, and it does not absorb water from the air.

7.7 Hybrid Processes

Hybrid processes are those that use a combination of biochemical, thermochemical, and/or chemical transformations.

For example, ethanol may be produced by acid hydrolysis of cellulose and hemicellulose (a chemical transformation described in Appendix M) followed by fermentation of the resulting sugars (a biochemical transformation).

However, most of the hybrid processes currently under development have syngas production as a first step. Syngas can be used in numerous processes to produce fuels and/or chemicals. For example, the following processes are possible:

- Alcohol production (methanol, ethanol, and other alcohols)
- Hydrocarbon production (gasoline, diesel fuel, jet fuel, and fuel oil)
- Hydrogen production

- Ammonia production
- Acetic acid production
- Other secondary products derived from the chemicals listed above

Heating biomass breaks up the organic molecule to yield syngas, a mixture of hydrogen, and oxides of carbon⁷. The process operates in two stages. In the first stage, biomass is heated to temperatures below 1100°F (600°C) in the presence of air, oxygen, or steam. Thermochemical reactions produce a mixture of carbon dioxide, carbon monoxide, tar, hydrogen, water vapor, char, and ash. In the second stage, the char is heated to 1440–1530°F (800–850°C). Reactions with oxygen, steam, and hydrogen yield carbon monoxide, carbon dioxide, and hydrogen. The overall reaction provides syngas as follows:

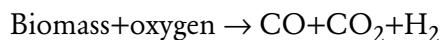

Syngas may be used as a fuel or as a feedstock to produce a wide array of fuels and chemicals. Some of the products made from syngas that are potentially important in energy supply are outlined below, along with their associated processes.

7.7.1 Ethanol

One possible use of syngas is the production of ethanol by Fischer-Tropsch synthesis (see Section 4.7).

7.7.2 Methanol

Fischer-Tropsch synthesis can also produce methanol from syngas (see Section 4.7).

7.7.3 Dimethyl Ether

Dimethyl ether, a potential transportation fuel, can be produced from methanol from Fischer Tropsch synthesis as described in Section 4.7.

7.7.4 Hydrocarbons

Hydrocarbons, including compounds constituting gasoline, can be produced by the Mobil M-gas process described in Section 4.7.

7.8 Biofuels Requiring No Processing

Biomass can release energy by burning, the oldest use of plant matter for energy production.

A small, but growing, application is the use of wood for home heating. Burning logs in fireplaces is a common, but not very efficient, home heating option. A newer home heating method is the use of furnaces designed specifically to burn wood efficiently.

Biomass may also be burned to provide process heat in some biomass-to-biofuel processes. Lignin, which cannot be hydrolyzed into simple sugars, is suitable for use as a process heat source.

Straight vegetable oil requires no processing for use in properly-equipped vehicle engines.

7.9 Biomass-to-Biofuel Process Overview

Various biomass-to-biofuel processes have been developed or are under development. These processes are summarized in Table 7-2.

Table 7-2. Biomass-to-Biofuel Technologies

Biofuel	Biomass Used	Transformation Process *	Maturity of Technology
BIOCHEMICAL PROCESSES			
Ethanol	corn, sorghum & sugarcane	enzymatic hydrolysis & fermentation	commercial
Ethanol	cellulose & hemicellulose	enzymatic hydrolysis & fermentation	developmental
Butanol	biomass	enzymatic conversion & fermentation	developmental
Biogas	any organics	anaerobic microbial digestion	small-scale commercial
Hydrogen	algae	photosynthesis	developmental
Methane	algae	photosynthesis	developmental
Triglycerides	algae	photosynthesis	developmental
Hydrocarbons	algae	photosynthesis	developmental
Hydrogen	biomass	algae by dark fermentation of biomass	developmental
Triglycerides	biomass	algae by dark fermentation of biomass	developmental
Hydrocarbons	biomass	algae by dark fermentation of biomass	developmental
THERMOCHEMICAL PROCESSES			
Pyrolysis Liquids	any biomass	pyrolysis	early commercial
Syngas	any biomass	gasification	developed, but not fully commercial
CHEMICAL PROCESSES			
Biodiesel	vegetable oils, fats & greases	transesterification	commercial
HYBRID PROCESSES			
Bioethanol	cellulose & hemicellulose	acid hydrolysis & fermentation	developed, but not commercial
Bioethanol	biomass	gasification & Fischer-Tropsch synthesis	commercial

Table 7-2 continued

Biofuel	Biomass Used	Transformation Process *	Maturity of Technology
Biomethanol**	biomass	gasification & Fischer-Tropsch synthesis	commercial
Gasoline	biomass	biomass to dimethyl ether to gasoline	early commercial
Hydrocarbons	triglycerides	decomposition and hydrogenation	developmental
Syngas Liquids (including gasoline, diesel fuel, jet fuel, and fuel oil)	any biomass	gasification & Fischer-Tropsch	developmental
Dimethyl Ether	any biomass	gasification, methanol synthesis, catalytic conversion	developed, but not yet commercial
BIOFUELS REQUIRING NO MOLECULAR RESTRUCTURING			
Straight Vegetable Oil (SVO)	vegetable oil	Pressing oil from biomass and food preparation residues	early commercial
Combustible Biomass	any dried biomass	Cutting, chipping or grinding	developed, but limited
<p>* Many processing variations exist or are envisioned. The processes mentioned are typical rather than specific.</p> <p>** Methanol is a potential biofuel, but it has some undesirable properties (most notably, toxicity) that will limit its use.</p>			

7.10 Looking Ahead

Biofuels will certainly be a part of our future energy supply, mainly for our transportation energy needs. It is not yet clear which of the many processes under development will dominate. Their use will depend partly on their cost relative to other options, including electricity to charge batteries or to produce hydrogen. However, the amount of land required to grow enough terrestrial biomass to produce adequate biofuel for current transportation

requirements is far too large to enable it to completely replace oil-based fuels. Algae can also provide suitable biomass for biofuel, but exploiting its high growth rates depends on developing cost-effective processes and facilities. Biofuels will satisfy only part of the U.S. need for transportation unless drastic curtailment of fuel consumption occurs.

References

1. Tester, J. W. et al. *Sustainable Energy* Cambridge: MIT Press, 2005.
2. Scurlock, J. "Bioenergy Feedstock Characteristics" Oak Ridge National Laboratory Report. At http://bioenergy.ornl.gov/papers/misc/biochar_factsheet.html.
3. "Algae: Biofuel of the Future?" *Science Daily*, August 19, 2008. At <http://www.sciencedaily.com/releases/2008/08/080818184434.htm>.
4. Spath, P. L. and Dayton, D. C. "Preliminary Screening-Technical and Economic Assessment of Synthesis Gas to Fuels and Chemicals with Emphasis on the Potential of Biomass-Derived Syngas" *National Renewable Energy Laboratory Report NREL/TP-510-34929*, December 2003.
5. Huber, G. W., (ed.) *Breaking the Chemical and Engineering Barriers in Lignocellulosic Biofuels* Arlington: National Science Foundation, 2008.
6. Roman-Leshkov, Y. et al. "Production of Dimethylfuran for Liquid Fuels from Biomass-Derived Carbohydrates" *Nature* no. 447, June 2007 pp. 982–985.
7. National Renewable Energy Laboratory Report "New Horizons for Hydrogen" at <http://www.nrel.gov/hydrogen/pdfs/49923.pdf>.

Exercises

- 7-1. An important study of biofuel energy potential is called the "Billion Ton Study." (The study and numerous updates and critiques can be found by a web search for "Billion Ton Study".) Estimate the biofuel energy recoverable from 1 billion tons of biomass if the conversion of biomass energy to biofuel energy is 30 percent. How does this amount of energy compare with current amount of energy used for transportation?

- 7-2. Biofuel production requires the transport of large quantities of biomass to processing facilities. Consider a plant that produces 100,000 gallons of ethanol per day. If 20 percent of surrounding farmland supplies the biomass, what is the maximum hauling distance? What is the average hauling distance? If the trucks used for hauling use 3,000 BTU per ton mile, how much energy is used for hauling? (Remember the trips by empty trucks to pick up the biomass.) If the biofuel produced is ethanol with energy content of 76,300 BTU per gallon, what fraction of the energy contained in the ethanol product is used for hauling?
- 7-3. Discuss similarities and differences between starch molecules and cellulose molecules.
- 7-4. Why is water always involved in the biochemical production of ethanol?
- 7-5. What are the arguments for and against the production of bioethanol fuel?
- 7-6. Use the Internet to discover the current status of the search for effective, economical enzymes for producing cellulosic ethanol. Discuss your findings.
- 7-7. Compare the arguments for and against biobutanol production over bioethanol production.
- 7-8. Use the Internet to determine current production and trends in bioethanol production. Discuss your findings.
- 7-9. Discuss the relative merits of terrestrial plants and algae in biofuel production.
- 7-10. How does the dark process for growing algae manage without sunlight?
-

- 7-11. Why are dark process algae growth chambers smaller than photosynthetic algae growth chambers of equal production rates?
- 7-12. Discuss the role of dimethyl ether in biofuel production.
- 7-13. Pretend that you are a journalist for a newspaper. Prepare an article on “How Much Oil Will Biofuels Replace in 2050?” You may use facts and your personal opinion, but identify which statements are based on facts and which are based on opinion.

8

Wind Energy

The Main Points

- **Uneven solar heating of the earth is the main initiator of atmospheric wind flows.**
- **Wind speed increases with elevation above the surface.**
- **Estimated U.S. wind energy potential is greater than current U.S. electricity production.**
- **The intermittency of wind energy imposes extra requirements on the electrical grid.**
- **Wind turbines with electrical power ratings of as great as 7 megawatts are available, and even larger machines are in design.**
- **Producing a Quad of electricity per year would require around 45,000 wind turbines if each had a maximum rating of 2.5 megawatts.**

8.1 Introduction

Wind is air in motion, and, consequently, it possesses kinetic energy. The purpose of a wind turbine is to transfer as much of that energy as possible to a rotating shaft that can then do mechanical work. The mechanical energy is most often used to drive an electric generator.

Uneven heating of the earth by the sun is the main initiator of atmospheric wind flows. Solar heating varies with cloud cover, the condition of the surface (water, ice, forest, desert, etc.), and the distance from the equator. Heated air rises in the warmer regions and is replaced by air flowing from cooler regions. In addition, surface features, gravity, and the earth's rotation influence wind direction and strength.

The total energy contained in the earth's winds is enormous (estimated to be about 2 percent of the solar energy that reaches the earth^{1,2}). This wind energy eventually degrades to heat through friction with objects and the atmosphere. Even though wind energy is diffuse and variable, it is an important and growing part of the world's energy supply.

8.2 Wind Energy Potential

A system for classifying wind energy potential is based on the specification of seven categories, as shown in Table 8-1.³

Table 8-1. Wind Energy Categories

Class	Wind Speed (mph) at 33 ft Elevation	Wind Speed (mph) at 164 ft Elevation
1	9.8	12.5
2	11.5	14.3
3	12.5	15.7
4	13.4	16.8
5	14.3	17.9
6	15.7	19.7
7	21.1	26.6

Winds of Class 3 and above are needed for practical wind energy applications.

The best approach for estimating the potential for wind energy is a detailed region-by-region analysis of average wind speeds, wind speed variability, and site suitability. The Pacific Northwest Laboratory (PNL), now renamed the Pacific Northwest National Laboratory (PNNL), has performed such an analysis³. The PNL report considered the capability of current and advanced wind machine technology, the availability of suitable winds, and the availability of land needed for wind machines (with possible shared use for farming or grazing).

With technology that can exploit winds of Class 3 and above, the estimated total U.S. wind energy potential is 16 to 57 electrical Quads per year. The range of values is due to differences in assumed exclusions of suitable lands because of demands for other use. Recall that annual electrical energy consumption in the U.S. is about 14 Quads (2010).

8.3 Wind Energy Physics

It can be shown (see Appendix P) that the power in moving air is given by

$$\text{Power} = (1/2)\rho Av^3 \quad (8-1)$$

where

- ρ = density of air
- A = cross-sectional area of the air stream (the same as the area facing the air flow to the turbine)
- v = speed of the wind

This expression shows the power in the air stream is proportional to the area swept by the blades of the wind turbine facing the air flow and proportional to the cube of the wind speed. It is important to note the cubic relationship between wind speed and power. For example, a doubling of the wind speed increases the power by a factor of eight (two cubed or $2 \times 2 \times 2$).

Practical devices for capturing wind power are capable of capturing only a fraction of the total power in the air stream. It has been shown that the maximum efficiency of power capture is 59 percent (the Lanchester-Betz-Joukowski Limit⁴, named after its discoverers), but actual machines are somewhat less efficient.

The capital expense of wind machines is justifiable in locations where the wind is adequately consistent and strong. As mentioned, an average wind speed of 12.5 miles per hour (Class 3 wind) is considered essential.

Wind speed increases with height above the ground⁵. The speed increases approximately as the 1/7 power of the height or

$$v_h = (v_o)(h/h_o)^{1/7} \quad (8-2)$$

where

- v_h = wind speed at a height h above the ground
- v_o = wind speed at a reference height h_o above the ground

Table 8-2 shows predicted wind speeds and power relative to the wind speed and power at 10 feet above the ground.

Table 8-2. Wind Speeds Relative to Wind Speed at 10 Feet Above the Ground

Height (ft)	Wind Speed/Wind Speed at 10 ft	Wind Power/Wind Power at 10 ft
10	1	1
20	1.10	1.35
50	1.26	1.99
100	1.39	2.69
200	1.53	3.62
500	1.74	5.36
1,000	1.92	7.21

Clearly, for maximizing power capture, it is advantageous to position wind machines as high as possible above the ground.

8.4 Wind Energy Machines

There are two main types of wind energy machines: horizontal-axis and vertical-axis.

Horizontal-axis machines have blades (usually three in number) mounted on a horizontal shaft. The shaft rotates in a housing that rests on a swivel

base atop a tall tower. In operation, the blades are oriented so as to face the wind. An electric generator in the housing converts shaft rotation into electricity. Typical horizontal-axis machines are shown in Figures 8-1 and 8-2.



Figure 8-1. A Horizontal-Axis Wind Turbine (courtesy of U.S. Dept. of Energy)

A typical large horizontal-axis wind machine has a rated power output of 2.5 megawatts electric (MWe). The size of these machines is impressive. They are mounted on towers that are about 275 feet tall, have blades that are about 145 feet long, and contain about 500 tons of steel. The trend is to ever larger machines (7 megawatt machines are available, and even larger machines are under development). The housing at the top of the tower for the power conversion equipment, called the nacelle, is large enough for a person to walk around inside while performing maintenance activities. Manufacturing wind machines is a huge, time-consuming activity. However, the prefabrication of components permits rapid installation.

Vertical-axis machines have blades mounted on a vertical tower. There are two main types of vertical-axis wind turbines: the Savonius type and the Darrieus type. Both are named after their inventor. The Darrieus machines

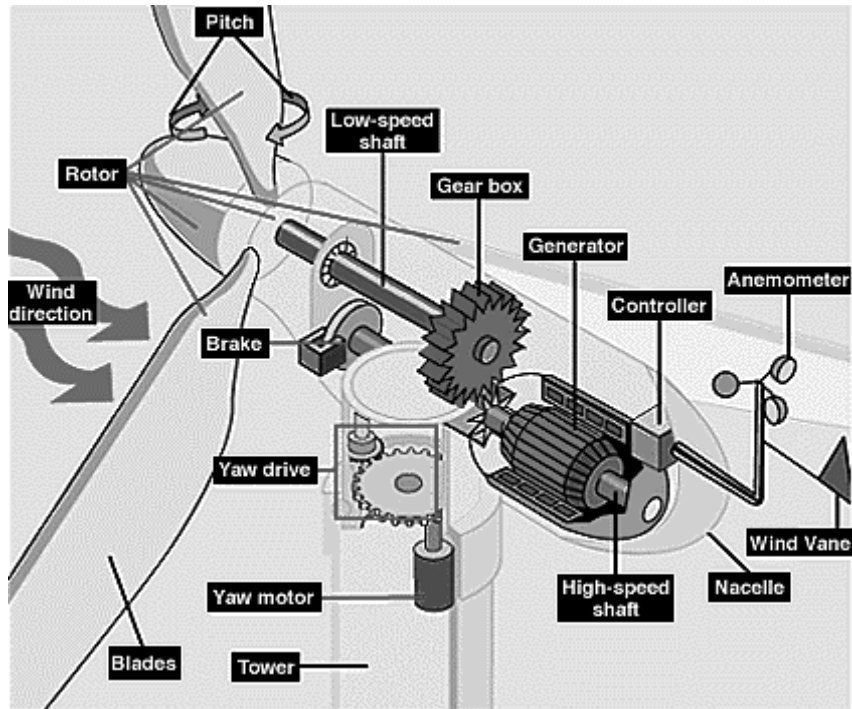

Figure 8-2. Horizontal Wind Turbine Internals (courtesy of U.S. Dept. of Energy)

use airfoils connected to a vertical shaft. A simple configuration appears in Figure 8-3. The Savonius machines have opposite-facing troughs on opposite sides of the vertical shaft around which they rotate (see Figure 8-4). Wind forces transfer more energy to the concave side than to the convex side, causing the rotor to spin around the axis. Variations on the Savonius and Darrieus designs have been conceived and are under development for possible commercial applications. It is generally thought Savonius machines are suitable only for small-scale applications, while Darrieus machines may be suitable for use in central station power plants, usually called wind farms.

Vertical-axis machines have their generators located on the ground, an advantage relative to horizontal-axis machines. However, the features of vertical-axis machines dictate a location close to the ground, where wind velocity is lowest, which is a disadvantage relative to horizontal-axis machines.

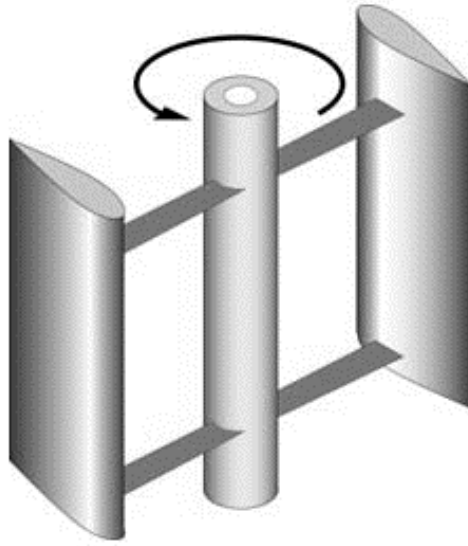

Figure 8-3. A Darrieus Wind Turbine (Giancarlo Rossi, Wikimedia, CC BY-SA 3.0)

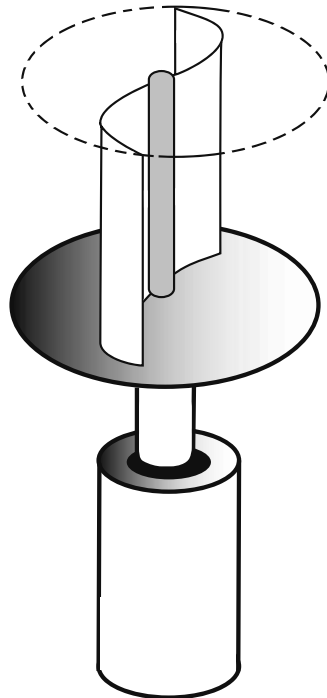

Figure 8-4. A Savonius Wind Turbine

Horizontal axis machines and vertical axis machines have some strong advocates, but horizontal-axis machines have captured all of the commercial market for large-scale production to date.

Wind machines in very cold climates require protection against ice build-up on the blades. Machines with heaters in the blades are available.

There is some interest in wind machines mounted on helium balloons. Proponents believe the higher speed and more persistent winds at higher altitudes are a benefit that could offset the greater complexity and cost of a balloon-mounted wind machine.

8.5 Intermittency

The variability of wind power imposes constraints on reliance on this energy source. Either excess energy from wind machines must be stored for use during windless periods and periods of low wind speed, or wind machines must be part of a system that includes other types of power producers that can compensate for temporary changes in wind power.

Possible energy storage strategies include hydrogen production by electrolysis, pumped water storage, and battery charging.

Fossil, nuclear, hydroelectric, and/or geothermal plants may be used to compensate for power needs caused by wind power changes due to wind intermittency. Since power supplied to the grid must instantaneously match electricity demands, any changes in power generation from one source must quickly be matched by compensating changes in power generation from one or more other sources. This matching of power generation to demand, called load following, is always required, but the requirement for ability to change power generation quickly in load following plants increases with the large and frequent power output changes from wind power. Not only does this type of load following cause increased wear and tear on generation equipment, it also causes affected plants to operate in a manner that may not be economically optimum, and it imposes additional demands on the

grid and increases the standby generation capacity that must be available when wind power generation decreases.

Most of the power plants assigned load following duty are fueled with natural gas. These plants are well-suited for load following because their capital cost is small compared to their operating cost, and they can come on stream quickly as needed. Hydroelectric plants are also well-suited for load following because they respond rapidly, and the water is available for use at any time without a performance penalty. Consequently, they share in load following duty even though their capital cost is much greater than their operating cost. Since nuclear plants have lower fuel cost and higher capital costs than fossil fuel plants, it is desirable to operate them at full power continuously.

8.6 Wind Machine Siting

Wind machines may be located on land or in the sea. Site suitability for either location depends on local average wind speeds and wind speed variability. Favorable U.S. sites are concentrated in the Midwest and along some coastlines. The top five states in terms of wind energy potential are North Dakota, South Dakota, Montana, Wyoming, and Minnesota. These states have suitable wind conditions and an abundance of open, sparsely populated land, much of which is used for farming or grazing. Wind machines can coexist with these activities, providing landowners with a new source of income. However, these areas lack the extensive electrical grid that is needed to transport electricity to areas with high demand. Building new transmission facilities would be required to bring the energy from these areas to where it is needed.

Some offshore locations offer suitably strong and consistent winds. This, along with a possible absence of competition for other uses of the site and (most often) proximity to electrical load centers near the coasts, makes offshore siting attractive. The disadvantages are the added cost and complexity of building and maintaining offshore rigs, the need for underwater transmission lines, vulnerability to strong storms, possible interference with fish-

ing, and the possible impact on shoreline scenery (a major source of opposition by shoreline residents, but not a problem for sites far enough away from the shore). Offshore systems may be built in shallow water on platforms that rest on the sea floor or in deep water on floating structures. Most offshore systems currently in operation are in shallow water, but the stronger and less-variable winds farther from shore and the elimination of structures that are visible from shore are motivating interest in deep-water systems.

8.7 Wind Energy Status and Prospects

In 2007, total world-installed wind energy capacity reached about 10,000 MWe, and U.S. capacity reached about 1500 MWe. The growth rate is at least 25 to 30 percent per year. Newer wind machine installations use large machines (2.5 MWe and larger) located in wind farms with multiple machines (for example, the Roscoe Wind Farm in Texas has 627 wind turbines with a combined capacity of 781.5 MWe.) For total world wind machine capacity of 10,000 MWe, and for operating at 30 percent availability, electricity production is 26.3 billion kilowatt hours per year or 0.09 Quads of electrical energy per year.

The U.S. wind energy production capacity in 2007 was around 0.013 Quads (about 0.1 percent of total U.S. electricity consumption). Clearly, wind energy production is growing rapidly, but it now provides only a small fraction of electricity production. If the growth of wind energy capacity continues at 30 percent per year, it will take around 15 years (from 2007) to reach a capacity of one Quad of electrical energy per year.

A single 2.5 MWe wind machine operating at 30 percent availability produces 6,570,000 kilowatt hours per year. Production of one Quad of electrical energy per year would require 45,000 such machines. Production of 45,000 machines would be a huge undertaking, requiring about 2 ¼ million tons of steel (about 2 ¼ percent of annual U.S. steel production).

Wind energy is destined to be a major energy source for the U.S. and the world in the future. Wind turbines can provide cost-competitive electricity with little environmental impact. The biggest hurdles are constructing enough machines to permit significant production, overcoming siting objections, dealing with intermittency (especially its impact on the electrical grid), and building transmission lines to carry the electricity from wind farms to users.

References

1. Tester, J. W. et al. *Sustainable Energy* Cambridge: MIT Press, 2005.
2. *McGraw-Hill Encyclopedia of Science and Technology*, 9th edition, Vol. 19, p. 559 New York: McGraw-Hill, 2002.
3. Elliott, D. L., Wendell, L. L. and Gower, G. L. "An Assessment of the Available Wind Land Area and Wind Energy Potential in the Contiguous U.S." *Pacific Northwest Laboratory Report PNL-7789* August 1991.
4. Van Kuik, G. "The Lanchester-Betz-Joukowski-Limit" *Wind Energy*, Vol. 10, 2007, pp. 289–291.
5. Wind Power Calculator at <http://windpower.generatorguide.net/wind-speed-power.html>.

Exercises

- 8-1. What is the maximum power available from a horizontal axis wind turbine with blades 100 feet long in a wind blowing at 18 miles per hour?
- 8-2. A farmer wants to use a wind turbine to pump water into an elevated tank located 25 feet above the ground, to be used to water his livestock. The average wind speed at an elevation of 50 feet is 14 miles per hour. He plans to place the turbine on a 50 foot tower. How much water could he pump into the tank on an average day

with a horizontal axis machine with blades 20 feet long? Assume the pump efficiency is 90 percent.

- 8-3. It is undesirable to have a large fraction of electricity production in a system from wind turbines. Why is this so?
- 8-4. A horizontal axis wind turbine has blades with a length of 145 feet. It produces 2.5 MWe for a certain wind velocity. How long should the blades be for a turbine that produces 5 MWe in the same wind?

9

Hydroenergy

The Main Points

- **Hydroenergy is energy derived from falling or moving water.**
- **Hydroenergy sources include impounded water sources, natural river elevation changes, river flows, tides, ocean currents, and waves.**
- **Suitable U.S. sites for large dams have been used. Smaller impoundments are now under consideration.**
- **Analysts estimate that new hydroenergy in the U.S. could provide around 1.4 Quads of electricity per year (10 percent of current electricity production).**

9.1 Introduction

Hydroenergy, as defined here, is energy contained in falling or moving water.

A huge quantity of water falls on the U.S. landmass as precipitation. This water undergoes three possible fates:

- It may evaporate.
- It may enter the soil and may be absorbed by plants. It may then be released back into the air, or it may become part of underground aquifers.
- It may enter rivers by surface runoff or through springs that release underground water.

As river water flows toward eventual discharge into the sea, it may pass through regions where impoundment with dams is feasible. It is generally desirable to build dams in locations where dam height can be maximized

with minimum land area flooded behind the dam. Therefore, mountainous or hilly regions are preferred over flat terrain for impounding water.

In some locations, rivers change elevation naturally over short distances. Water may be withdrawn from an upstream, elevated takeoff point and transferred through a pipe or tunnel to a turbine-generator at a lower elevation, where it is returned to the river. The Niagara Falls power plant is an example of this type of system.

Water in rivers, oceans, and estuaries experiences motion and, therefore, possesses kinetic energy that may be captured for producing electricity. River flow rates vary, but some flow typically occurs constantly. Tides cause water currents to flow into and out of estuaries and cause periodic changes in water depth. Waves cause periodic increases and decreases in water depth. Ocean currents, such as the Gulf Stream, possess energy that may someday be tapped to produce electricity to be transferred to shore.

9.2 Physics of Falling Water Energy

The potential energy in elevated water may be tapped to produce electricity. Sites where large quantities of water fall through large elevation changes provide good sites for hydropower generation.

Appendix P provides formulas for the power available from falling water. The basic formula is as follows:

$$P = gfh \quad (9-1)$$

where:

P = power

g = gravitational constant

f = mass flow rate

h = height

Appendix P gives formulas with factors expressed in various sets of units. Here, we will illustrate the calculation of power production using two different sets of units. One set uses flow expressed in cubic feet per second and height expressed in feet. The other set uses flow expressed in kilograms per second and height in meters. The formulas (see Appendix P) are as follows:

$$P(\text{watts}) = 84.6 \times \text{flow (in cubic feet per second)} \times \text{height (in feet)} \quad (9-2)$$

or

$$P(\text{watts}) = 9.81 \times \text{flow (in kilograms per second)} \times \text{height (in meters)} \quad (9-3)$$

Example 9.1

Calculate the energy in water falling 200 feet at a rate of 50,000 cubic feet per second.

$$P(\text{watts}) = 84.6 \times 50,000 \times 200 = 846 \times 10^6 \text{ watts or } 846 \text{ megawatts}$$

Now repeat the calculation using SI units. A height of 200 feet is equal to 61 meters. The mass flow rate is given by:

$$\text{Flow (kilograms per second)} = 50,000 \text{ (cubic feet per second)} \times 62.4 \text{ (pounds per cubic foot)} \times 0.4545 \text{ (kilograms per pound)} = 1.42 \times 10^6 \text{ kilograms per second.}$$

Equation 9.3 gives the following result:

$$P(\text{watts}) = 9.81 \times 1.42 \times 10^6 \times 61 = 846 \times 10^6 \text{ watts or } 846 \text{ megawatts.}$$

This example illustrates that the formulas for SI units and for U.S. Customary units are consistent.

9.3 Turbines and Generators

The electrical power produced by a hydroelectric turbine-generator is somewhat less than the power in the falling water because of inefficiencies in the

conversion to mechanical power in the turbine and the subsequent conversion from mechanical power to electrical power in the generator. Typical large turbine-generators convert the power in falling water into electrical power with an efficiency of around 90 percent or higher. Figure 9-1 shows a typical hydroelectric turbine-generator.

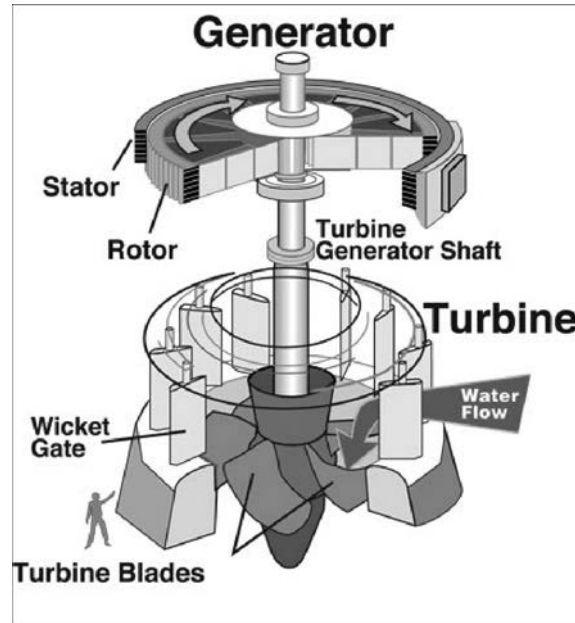

Figure 9-1. A Hydraulic Turbine-Generator (courtesy of U.S. Army Corps of Engineers)

9.4 Falling Water Hydroelectric Systems

9.4.1 Large Commercial Systems

Large dams with electrical generating capacities of 30 to 2,000 megawatts are scattered around the U.S. Figure 9-2 shows the main components of a large electricity-producing dam. These large dams are generally found where river flows are great, where suitable topology exists for high dams, and where the terrain permits deep reservoirs without excessive surface area. There are about 2,400 such dams in the U.S., with a total generating capac-

ity of around 35,400 megawatts. These facilities produce about 0.9 Quads of electricity per year (about 6.5 percent of total U.S. electricity production).

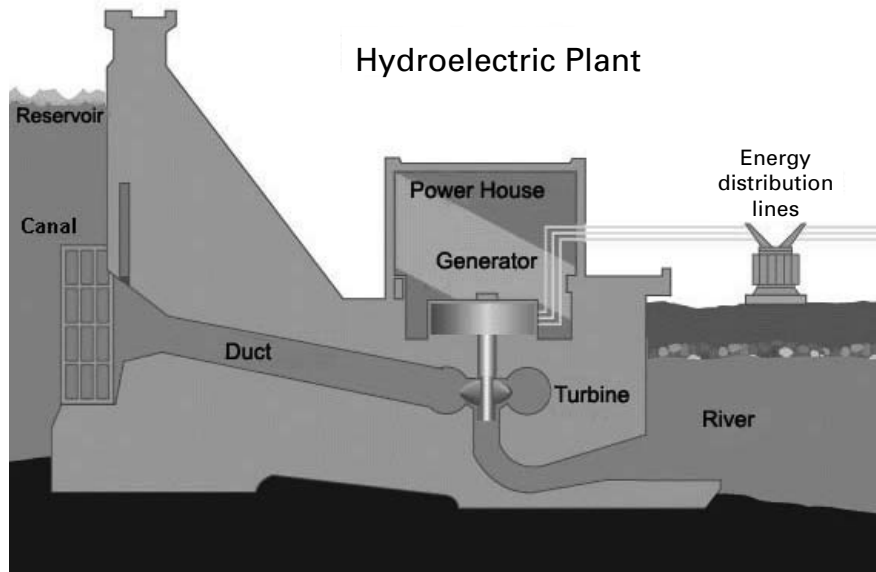

Figure 9-2. A Hydroelectric Dam (courtesy of Tennessee Valley Authority)

Since all of the best sites have been used, there is no possibility of significant new construction of large dams. However, sites still exist for smaller dams (less than 30 megawatts).

9.4.2 Small Commercial Dams

Since the sites that are suitable for large power-producing dams in the U.S. are essentially all in use, and because of a recognized need for an increase in sustainable and non-polluting energy, interest in exploiting sites with smaller generating capacity is increasing. Sites suitable for small (less than 30 megawatts) dams exist in many locations. In some cases, small dams already exist, but have no turbine-generator. Some other sites have natural elevation changes in stream flow that can be used for power generation without requiring a dam.

9.4.3 Small Private Systems

Small hydroenergy systems can provide mechanical or electrical energy for individuals who have a stream on their property. If a stream flows down a hillside or over a cliff, then the source of elevated water can feed a raceway or penstock that delivers water to the bottom of the hill. In this way, it may be possible to achieve an elevation change without building a dam. Such systems can provide nearly free energy after the construction cost has been paid.

Renewable energy advocates often state that enough off-grid power can be produced by local, renewable hydroenergy sources to satisfy the needs of a typical family. In order to avoid disappointing performance, it is essential to assess the quantitative capability of typical local energy resources. The formulas in Section 9.2 provide the capability to estimate the achievable power generation for specific stream flow rates and elevation changes.

9.5 Pumped Storage

Pumped storage systems use pumps to deliver water to elevated reservoirs (as on a mountain top). Pumping power is provided by power plants that would otherwise be idle because of low electricity demand. When electricity demand is high, the elevated water is released to turbine-generators at the lower elevation. The turbine-generator is reversed and used as a pump when pumping is required. Figure 9-3 shows a pumped storage system.

Pumped storage is especially effective in systems with power plants that have low operating costs and can operate at night, when electricity demand is typically low. Wind turbines, geothermal systems, and nuclear power plants all have low operating costs. (They typically have higher capital costs than fossil-fuel plants, but these capital costs continue whether the plant operates or not.) Since operating costs (mostly fuel costs) for fossil fuel power plants are the major part of their total power costs, they are not well-suited for providing pumping power for pumped storage. Since solar generators are idle at night when pumping power is needed, they are not suitable for providing pumping power for pumped storage.

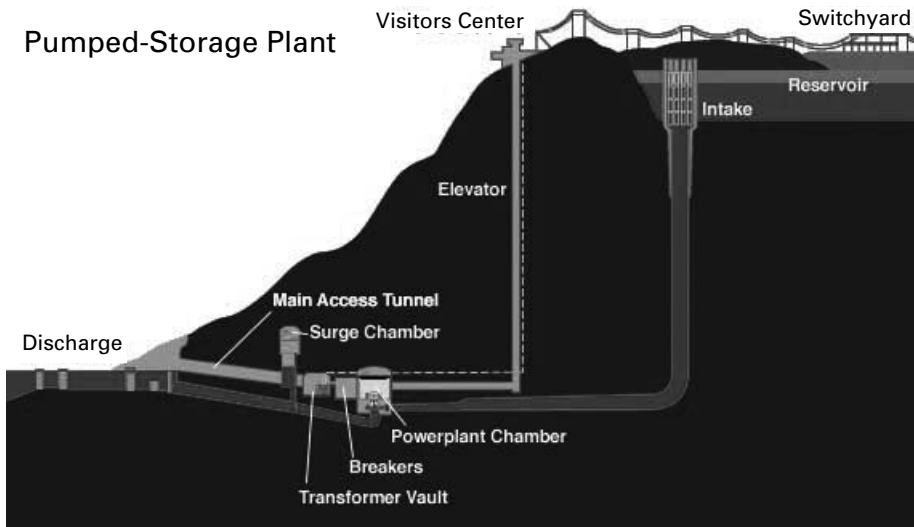

Figure 9-3. A Pumped-Storage Facility (courtesy of Tennessee Valley Authority)

The Raccoon Mountain Station is a large facility operated by the Tennessee Valley Authority near Chattanooga, Tenn¹. TVA built a 230-foot-high dam on top of Raccoon Mountain to create a 528-acre reservoir. Water falls 990 feet when the facility is producing power. Electrical generation capacity is over 1,500 megawatts. Of course there are energy losses associated with pumping the water uphill, but the benefits outweigh this loss.

9.6 River Flow, Tidal Flow, and Ocean Current Energy Converters

Flowing water possesses kinetic energy that can be captured by a submerged turbine and transformed into electricity. These are called hydrokinetic or, for applications in rivers, run-of-river systems. The principle of operation is the same as for a wind turbine. The basic formula for the power that is possessed by flowing water is given by:

$$P = 1/2\rho Av^3 \quad (9-4)$$

where

P = power possessed by flowing water

ρ = water mass density

A = the area swept by turbine blades, equal to πr^2

v = water velocity

Since the density of water is over 800 times the density of air, much greater power is produced for a given fluid velocity and turbine blade length. Of course, a turbine cannot capture all of the water's power. The theoretical maximum efficiency of power extraction from flowing water is 59 percent. This is the Lanchester-Betz-Joukowski limit, which also applies for wind turbines. Nevertheless, water turbines can capture a significant fraction of the stream power.

A formula for the power of a flowing water stream is obtained by substituting values for density and π into Equation 9-4 and converting units (in this case, foot pounds per second into watts). The result, as shown in Appendix P, is:

$$P(\text{watts}) = 4.13 r^2 f^3 \quad (9-5)$$

where

P = power in the water stream impinging on the turbine blades

r = radius of area swept by the turbine blades (feet)

f = water flow rate (feet per second)

Applying the Lanchester-Betz-Joukowski limit gives the maximum power that can be captured by the turbine:

$$P(\text{watts}) = 2.44 r^2 f^3 \quad (9-6)$$

Example 9.2

A turbine with 10 foot blades in water flowing at 10 feet per second would have a maximum power extraction capability of:

$$P_t = 2.44 \times 10^2 \times 10^3 = 244,000 \text{ watts or } 244 \text{ kilowatts.}$$

Actual power production would be somewhat less because of losses in the turbine-generator.

Water currents that are potentially exploitable are river currents, tidal flows, and ocean currents. River current systems and tidal flow systems are similar except that tidal flow systems produce power that varies periodically with changes in flow rates and also reverses direction. Also, river systems are located in fresh water, and tidal systems are located in salty or brackish water, with an associated impact on selection of materials due to potential corrosion.

Huge ocean currents are tempting sources of useful power. To capture this power, systems must be designed that can operate far offshore, and reliable and practical transmission systems for delivering the energy to the shore must be made available.

Hydrokinetic power systems in navigable channels must be submerged deep enough to avoid interference with boats or ships that use the waterway. Consequently, submerged systems must usually use an array of small-diameter turbines rather than large units such as are used for wind energy.

As is true for any system that intrudes on an ecosystem, there is some concern about the effect of hydrokinetic systems on the aquatic habitat. Installations must result in little or no impact on fish and other aquatic creatures.

Suitable sites for hydrokinetic power systems are often very close to load centers, permitting power delivery without long transmission lines.

9.7 Wave Energy Converters

Wave energy converter devices all are installed at or near the surface of the water. Several types of converters are currently being developed:

- Terminator devices extend perpendicular to the direction of wave travel. One design is the oscillating water column device. It consists

of a tethered cylinder whose bottom is open to the ocean. Air is trapped above the water column and is compressed when the water rises during wave cresting. The compressed air is released through a turbine to produce mechanical energy that drives an electrical generator.

- Point absorbers also extend perpendicular to the direction of wave travel. They consist of two concentric cylinders. The outer cylinder is moored and stationary. The inner cylinder floats and moves up and down with wave motion. If one of the cylinders houses a magnet and the other houses a conductor, then electricity is produced in the conductor as a result of the motion.
- Attenuators extend along the direction of wave travel. They are multi-segment floating structures, which bend at the interfaces between segments as waves pass. The bending can drive a pump, producing flow that can drive a turbine-generator.
- Overtopping systems consist of reservoirs that are filled by cresting waves. The wave height can be increased by using funnel-shaped channels leading to the reservoir. The water is released through an energy conversion mechanism such as a turbine-generator during wave troughing.
- Pendular devices consist of structures with hinged flaps that face incoming waves. The flaps swing back and forth with wave motion. This flap motion can drive a pump that moves fluid through an energy converter such as a turbine-generator.
- Elastic systems consist of an elastic hose that is tethered to the bottom and connected to a float. The up-and-down wave motion stretches and relaxes the hose, forcing up-and-down motion of water through the hose.

The diversity of these concepts suggests additional ingenious designs are under development or will evolve.

9.8 Tide Energy Converters

Tide energy converters are defined here as those that use the potential energy resulting from a change in water elevation caused by tides rather than the kinetic energy of tidal flows. The approach is to trap water in a reservoir at high tide, then release it through turbines at low tide. Of course, areas with large tides are preferred for tide energy converters. The ideal location is a bay having large tides and a passage to the open sea that is suitable for locating a dam (also called a *barrage*).

A tide energy system has been built on the Rance River near St. Malo, in France. It produces 240 megawatts of electricity.

Tide energy converters clearly can produce electrical energy in the few places in the world where conditions are right, but these systems inevitably affect the local aquatic ecosystem.

9.9 Hydroenergy, Environmental Effects, and Public Safety Concerns

Hydroenergy is often considered neutral with respect to environmental effects because it involves no release of pollutants or greenhouse gases. However, there are other environmental effects that warrant consideration. Some concerns are:

- Flooding large land areas when dams are built, thereby potentially eliminating farmland, relocating populations from affected areas and flooding historically significant regions.
- Changing the aquatic habitat, thereby affecting the survival of some aquatic creatures and eliminating traditional migration paths for some species.
- Reducing the natural transfer of silt to lower elevations, where it previously enhanced the fertility of the soil.

Of course, there are also effects that are considered beneficial in addition to the production of electricity. These include:

- Creating lakes with opportunities for recreation
- Controlling floods

The main safety concern related to hydropower from dams is dam failure. Dams are huge structures that appear to be permanent. However, experience shows that dams can fail, with catastrophic downstream consequences. Dam monitoring is crucial, and releasing impounded water must occur when dam integrity comes into question.

9.10 Hydroenergy and Load-Following

Electricity production must match electrical demand on the grid, and this matching must be very rapid. Hydropower systems based on falling water are well-suited for providing rapid load-following capability. Opening or closing a valve that admits water to a turbine causes an immediate change in the transfer of energy to the turbine and the generator. Thermal power plants can achieve changes in steam flow by valving, but changes in energy extraction must be matched shortly thereafter by changes in combustion rate or nuclear fission rate. Because of their superior load-following characteristics, hydropower from dams is often relied on for short-term matching of generation to demand.

9.11 Hydroenergy Contribution to Energy Needs

Electricity consumption in the U.S. is currently about 4 trillion kilowatt hours per year. Estimates of new hydroenergy potential capacity are very uncertain, but an estimate of around 400 billion kilowatt-hours per year (around 1.4 Quads of electricity per year) has been published². This electrical energy includes 260 billion kilowatt-hours per year from waves, 19.6 billion kilowatt-hours per year from tidal currents and 110 billion

kilowatt-hours per year from river currents. To date, little actual implementation of these newer, unconventional hydroenergy systems has occurred, but prototype systems are being tested as possible precursors to large, practical installations.

It should be noted that Canada has much greater hydroenergy potential (1,600 billion kilowatt-hours per year).

The estimates indicate new hydroenergy systems might provide around 10 percent of the 2010 electricity production level if fully developed in the U.S. This is a significant amount of energy (comparable to the energy available from forty large nuclear power plants), but hydroenergy alone cannot provide needed future increases in energy production.

References

1. Tennessee Valley Authority report, available at <http://www.tva.gov/sites/raccoonmt.htm>.
2. Bedard, R., et al. "North American Ocean Energy Status—March 2007" *Report to 7th European Wave and Tidal Energy Conference*, Porto, Portugal, September 2007. Available at http://oceanenergy.epri.com/attachments/ocean/reports/7th_EWTEC_Paper_FINAL_071707.pdf.

Exercises

- 9-1. A farmer has a creek on his property. He is considering installing a small hydroelectric system. He is considering the use of a penstock to collect water at a location 20 feet above the point of energy extraction and return of the water to the creek. The water flows in the creek at a rate of 20 cubic feet per second. How much electricity (watts) can he produce if half of the flow is diverted through the penstock and the mechanical to electrical conversion efficiency is 90 percent? How much is the electricity worth per day if the current price for electricity is 11 cents per kilowatt-hour?

- 9-2. Knox County, Tenn., has an area of 526 square miles and an average elevation of around 900 feet above sea level. It gets around 50 inches of rainfall per year. If half of this water flows through the rivers to the Gulf of Mexico, how much energy is released? Where does this energy come from?
- 9-3. The Gulf Stream is a massive stream of water flowing at around 30 million cubic feet per second in the Florida Straits. The flow rate is around 1 meter per second. How much energy (BTUs and kilowatt-hours) is contained in one cubic meter of this flowing water? How much power (megawatts and BTU per day) is contained in the whole stream? (Recall the kinetic energy is given by $KE = 1/2mv^2$. Power is the rate of energy flow or $P = 1/2(dm/dt)v^2$, where dm/dt is the mass flow rate.)
- 9-4. At New Orleans, the Mississippi River flows at an average rate of around 600,000 cubic feet per second. How much kinetic energy does the river possess if the speed of flow is 5 miles per hour?
- 9-5. Explain, in simple terms, why it is impossible to extract all the kinetic energy from flowing water.
- 9-6. Hoover Dam produces 2,080 electrical megawatts using water that drops 526 feet. Estimate the mass flow rate of water through the turbines. Assume a mechanical to electrical conversion efficiency of 90 percent.

10

Geothermal

Energy

The Main Points

- At depths of around 30 feet, soil temperature is nearly constant year-round.
- At depths greater than around 400 feet, temperature increases with depth (1.0 to 1.7°F per 100 feet).
- In some locations, hydrothermal sources exist. These sites have near-surface hot rock with adequate permeability to allow naturally occurring water to capture heat.
- Enhanced geothermal systems are those in which permeability is induced in hot, dry rock by fracturing and water is then injected.
- Enhanced geothermal systems are potentially a very large energy source, but the effort that would be needed to modify huge underground rock formations is also large.
- Geothermal heat pumps exploit the constant near-surface underground conditions as a heat source or heat sink as needed.

10.1 Introduction

The interior of the earth is hot. Some of the heat is attributed to energy released in the initial formation of the planet. In addition, radioactivity of elements in the earth produces a huge amount of heat energy. Heat flow to the surface is impeded by the rather poor heat transfer characteristics of the materials that comprise the earth's interior. This trapped heat has raised the temperature of earth materials. In some locations, this hot material is near the surface, and occasionally lava reaches the surface in volcanic eruptions. In some locations, water that has seeped into the depths is heated and trapped, or returns to the surface as hot water or steam. This “free” energy is there for the taking.

In addition, hot dry rock lies beneath the earth's entire surface and is a potential future source of useful energy. Accessing this energy requires human intervention to modify sub-surface conditions and to introduce water for transporting energy to the surface.

The earth also provides an opportunity to increase the efficiency of heating and cooling with heat pumps. The near constant temperature that exists a few feet below the earth's surface is better suited than ambient air for use as a heat source or heat sink in heat pump applications.

At the time this chapter was written, increased interest and activity related to geothermal energy was apparent. Numerous publications appeared, most notably three reports, one by the Massachusetts of Technology,¹ one by the U.S. Geological Survey,² and one by the U.S. Department of Energy³. Information from these reports was used extensively in preparing this chapter.

10.2 Sub-Surface Conditions

The earth has a radius of approximately 4,000 miles. The interior consists of three main concentric regions. The innermost region, the core, extends from depths from 1,800 miles to 4,000 miles. The core itself consists of two regions: the solid inner core and the liquid outer core. The intermediate concentric region is a 1,800-mile-thick region called the mantle, also consisting of two regions. The temperature ranges from around 2,000°F at the top of the mantle to over 8,000°F in the core. The top part of the mantle is a hot liquid rock called magma. The thin topmost layer (around 15 to 45 miles thick under landmasses) is the crust on which we live (see Figure 10-1).

The high subterranean temperatures provide a driving force that causes a continuous flow of heat to the earth's surface. The total rate of heat flow to the surface from the earth's interior is estimated to be about 45 million megawatts⁴ (around 1,300 Quads per year). This is a huge amount of power, but it is less than one-thousandth as large as the solar radiation power absorbed by the earth's surface (as shown in Chapter 5, this is about 174

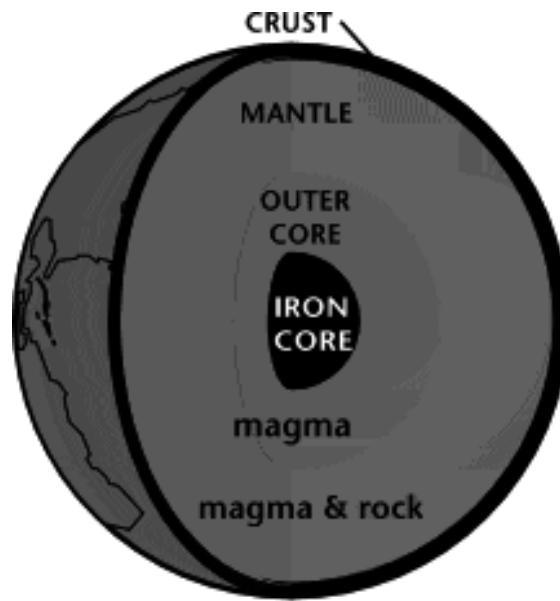

THE EARTH'S INTERIOR

Figure 10-1. The Earth's Interior (courtesy of U.S. Dept. of Energy)

watts per square meter or 22 billion megawatts for the total earth surface). 45 million megawatts is approximately the thermal power that could be produced by 14,000 very large nuclear power plants. (Nevertheless, it is so small compared to incoming solar power that it plays an insignificant role in weather.)

The earth produces energy flow (power), and it contains stored energy in hot rocks. Exploitation of the earth's heat for practical purposes involves the extraction of a portion of the stored energy.

To a depth of 200 to 400 feet, atmospheric conditions and circulating ground water dominate temperatures. At greater depths, these effects become small compared to the effect of heat flow from the interior. The temperature of the earth below about 400 feet increases as depth increases. This increase is quantified by the geothermal gradient, defined as the temperature increase per unit increase in depth. The geothermal gradient is

expressed as °C/km or °F/100 ft⁵. Geothermal gradient values range from about 17 to 30°C/km or 1.0 to 1.7°F/100 feet.

To extract energy from the stored subterranean heat, the heat must be transferred to a liquid or gas that can carry the energy to the surface. The ability of underground material to allow fluid passage is determined by its porosity and permeability, defined as follows:

- Porosity: The percentage of open spaces within rock.
- Permeability: The ability of pores in rock to permit the flow of liquids or gases under a pressure gradient. This ability depends on the connection between pores as needed to permit flow.

Access to rocks with adequate permeability is necessary for extracting geothermal energy. Adequate permeability occurs naturally in some rock formations and can be induced in others.

10.3 The Resource

In view of the amount of geothermal energy possibly within reach, it is important to assess the potential of geothermal energy to become a significant contributor to total energy supply. There are two types of geothermal energy systems: hydrothermal systems and enhanced geothermal systems. The necessary condition for either type of geothermal system is the presence of hot rocks with adequate permeability to permit the required flow of water.

Hydrothermal systems are those in which the necessary rock condition occurs naturally, and the necessary water is naturally present. Extracting the energy is basically a matter of drilling an extraction well. Enhanced geothermal systems (sometimes called engineered geothermal systems) are those in which subsurface rocks are modified by human intervention, and water is then introduced to be heated and brought to the surface.

The size of the geothermal resource that can be exploited for practical energy production remains a subject characterized by considerable uncertainty. For example, on page 10 of a 2003 U.S. Geological Survey (USGS) report², it is stated that “With current and foreseeable technologies, the hydrothermal environment is the only commercially exploitable form of geothermal energy for producing electricity.” Then, only five years later, the USGS published a new assessment⁵ that estimated that the potential for enhanced geothermal systems in the U.S. is 517,800 megawatts of electricity (equal to the power from over 500 large nuclear power plants). Another important publication by an MIT-led interdisciplinary panel¹ concluded that enhanced geothermal systems could provide 100,000 megawatts of competitive electricity within 50 years. The rapidly-changing assessments and the lack of agreement between highly-qualified teams underscore the difficulty and uncertainty associated with assessing the technical and economic potential of enhanced geothermal systems. Nevertheless, the important conclusion is that, while experts may disagree on the size of the usable geothermal resource, they agree that enhanced geothermal systems have the potential to contribute significantly to satisfying future energy needs.

Extracting geothermal energy requires drilling into the earth to reach the stored energy. A huge body of technology has been developed for drilling oil and gas wells. Even though this technology is not totally applicable to geothermal applications, it gives confidence that geothermal wells could reach depths of up to 6 miles as needed for extracting useful energy.

10.4 Hydrothermal Sources

As defined above, underground formations with adequate stored heat energy, adequate natural permeability, and adequate natural sources of water feeding the formation are called *hydrothermal sources*. These sites are generally located in regions where tectonic plates intersect. Motion of the plates creates fracture zones in the rock that allow water to enter and receive heat. The resulting hot water or steam can rise to the surface or be trapped underground by overhead rock.

Drilling into hydrothermal sources releases steam or hot water. These sources are the easiest geothermal sources to exploit. They account for all of the geothermal energy currently produced worldwide. The occurrence of this fortuitous combination of conditions for providing hydrothermal sources is not common, and all U.S. sites are in western states.

The steam or hot water is brought to the surface and used to power a turbine-generator to produce electricity or used directly for space heating. The water remaining can be released on the surface or, more commonly, pumped back into the hydrothermal reservoir.

10.5 Enhanced Geothermal Systems

Hot, dry rocks contain much more stored energy than hydrothermal sources, and they exist under all the earth's surface; however, they lack permeability and natural water supplies. To exploit this energy resource, it is necessary to create the necessary permeability and then to pump water (or other fluid) through the rock to extract the heat. Geothermal sources that are stimulated in this way are called enhanced geothermal systems.

The first step in creating an enhanced geothermal system is to drill one or more wells into the hot rock. Then high-pressure water, possibly containing chemicals to enhance fracturing, is injected. The purpose of doing this is to create many small passages that maintain intimate contact between the water and the surrounding rock. Large passages are undesirable because they would permit channeled water flow through the rock formation without the contact required to extract heat efficiently from the rock. The process is called hydrofracturing, and its viability has been demonstrated in the oil and gas industries. The oil and gas experience suggests the desirability of including proppants in the injected water. Proppants are small solid particles whose purpose is to keep passages open once they have been created by hydrofracturing.

After hydrofracturing is complete, water is introduced under pressure into the fractured zone through one or more injection wells. One or more pro-

duction wells provide a lower pressure region to which the injected water flows. The temperature of the injected water increases as it passes through the fractured zone, producing steam or hot liquid water. Ideally, the fractured zone is surrounded by impermeable rock, thereby avoiding the loss of injected water. Water loss is an issue in determining the suitability of a location for an enhanced geothermal system, especially in regions where water is scarce.

Rock temperature increases with well depth, but well depth is limited by available drilling capability, especially for drilling in hot, deep environments. Facilities with extracted fluid temperatures of 250 to 300°F are mainly useful for space heating applications. Fluids from deeper wells with higher temperatures (currently up to around 700°F) are useful for producing electrical energy.

Energy extraction from hydrofractured rock will cool the rock over time, causing the energy extraction capacity to decrease. At some point, extraction would cease. Heat transfer from surrounding rocks would then slowly re-heat the rocks in the idle fracture zone, permitting resumption of energy extraction after decades of rest (possibly 100 years)¹.

The amount of useful energy available from an enhanced geothermal system depends on the fractured rock volume in contact with the water, the temperature drop induced by heat transfer from the rock to the water, and the efficiency of conversion of the extracted thermal energy into useful energy (typically electricity). The electrical energy production is given by

$$E = \rho VC\Delta T_e \quad (10-1)$$

where

- E = useful energy (BTU)
- ρ = rock density (approximately 160 pounds per cubic foot)
- V = fractured rock volume (cubic feet)
- C = rock-specific heat capacity (approximately 0.24 BTU per pound per degree Fahrenheit)

- ΔT = temperature drop in rock during duration of extraction period (degrees F)
- e = efficiency of conversion from thermal energy in extracted fluid to electrical energy

Substituting values for density and specific heat capacity and expressing fractured rock volume in cubic miles gives:

$$V\Delta Te = 177E(\text{in Quads}) \quad (10-2)$$

The weight, W , of the rock that must be fractured is given by

$$W = E/C\Delta Te \quad (10-3)$$

Substituting the value for C , expressing E in Quads, and expressing W in millions of tons give:

$$W(\text{millions of tons}) = 2,100 \times E/(\Delta Te) \quad (10-4)$$

Finally, the average power is given by the energy extraction per unit time. Converting energy into megawatt-hours and introducing the duration of operation of the system, Y , gives

$$P = 190V\Delta Te/Y \quad (10-5)$$

Example 10.1

It is desired to obtain 1 Quad of energy from a rock formation by reducing the rock temperature by 100 °F, with conversion to electricity occurring with an average efficiency of 0.15. The lifetime of the system is taken to be 20 years.

The volume of fractured rock required is:

$$V = 17/(100 \times 0.15) = 11.8 \text{ cubic miles.}$$

The weight of rock to be fractured is:

$$W = 2,100 \times 1/(100 \times 0.15) = 140 \text{ million tons.}$$

The average power is:

$$P = 190 \times 11.8 \times 100 \times .15 / 20 = 1,682 \text{ megawatts.}$$

This example illustrates the promise and the limitation of enhanced geothermal system energy. 1,682 megawatts is a lot of power (comparable to that of a very large nuclear power plant), but 140 million tons is a lot of rock to access and fracture.

The technology for enhanced geothermal systems is fully formulated, but as yet, it is unproven. The estimated energy available from enhanced geothermal sources is enormous; it provides energy with little or no pollution, and it avoids expenditures for foreign energy supplies. However, the practicality of creating suitably large underground fracture zones is yet to be demonstrated. To obtain a significant quantity of energy from enhanced geothermal energy would require the creation of thousands of cubic miles of fractured rock far below the earth's surface.

10.6 Geothermal Energy for Heat and Electricity

The ubiquity of potential enhanced geothermal energy sites creates the possibility of locating energy sources close to the locations where the energy would be consumed. This would reduce the costs and energy losses associated with long-distance electricity transmission or fuel transport.

Proximity of energy sources and energy consumers also increases the possibility of using hot water for space heating in buildings. Hot water pumped through insulated pipes could deliver heat to homes, businesses, and factories near a geothermal source. This technology has already been implemented in those locations where hydrothermal sources are close to energy consumers. Tapping the energy in enhanced geothermal sources would open the possibility for geothermal space heating in many more locations.

Electricity may be produced using geothermal energy as a source of steam to drive turbine-generators. Three types of geothermal power plants are

envisioned. In locations where dry steam is available, power plants would use steam fed directly to a turbine. In locations where hot water or steam-water mixtures are available, a flash steam system could be used. In flash steam systems, the water or steam-water mixture is introduced into a lower pressure region where evaporation produces steam to be fed to a turbine. In locations where the geothermal fluid temperature is lower (200 to 300°F), a binary cycle power plant would be used. In binary cycle power plants, heat is transferred to a second fluid with a lower boiling point than water, and the resulting vapor drives a turbine. These systems are illustrated in Figures 10-2 through 10-4. In all three types of geothermal power plants, the water drawn from the underground formation is pumped back into the formation.

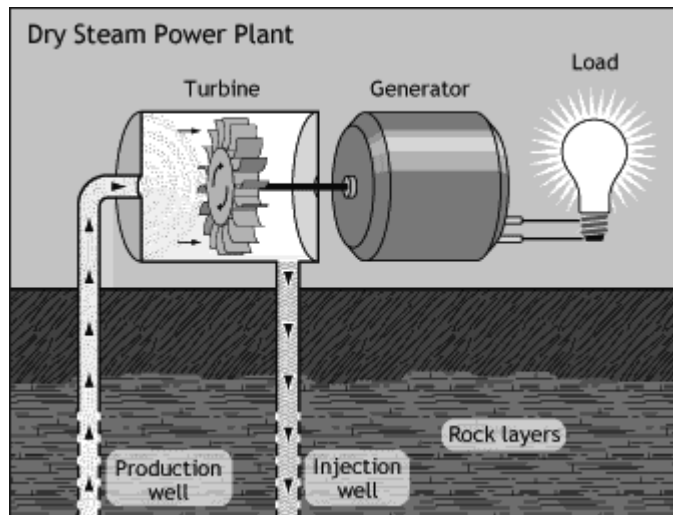

Figure 10-2. A Dry-Steam Geothermal Power Plant
(courtesy of U.S. Dept. of Energy)

The conversion of heat energy to electrical energy is limited by the thermodynamic efficiency of the process. As shown in Section 2.6, thermodynamic efficiency increases with increasing temperature of the working fluid. Because of the lower temperature of available working fluids, geothermal

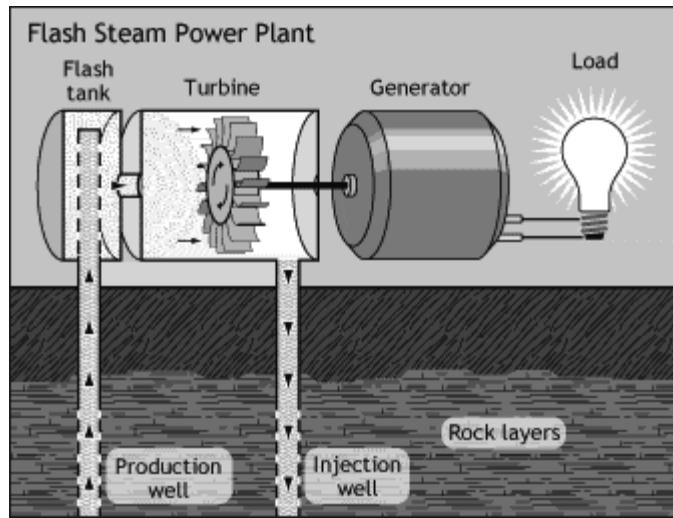

Figure 10-3. A Flash-Steam Geothermal Power Plant (courtesy of U.S. Dept. of Energy)

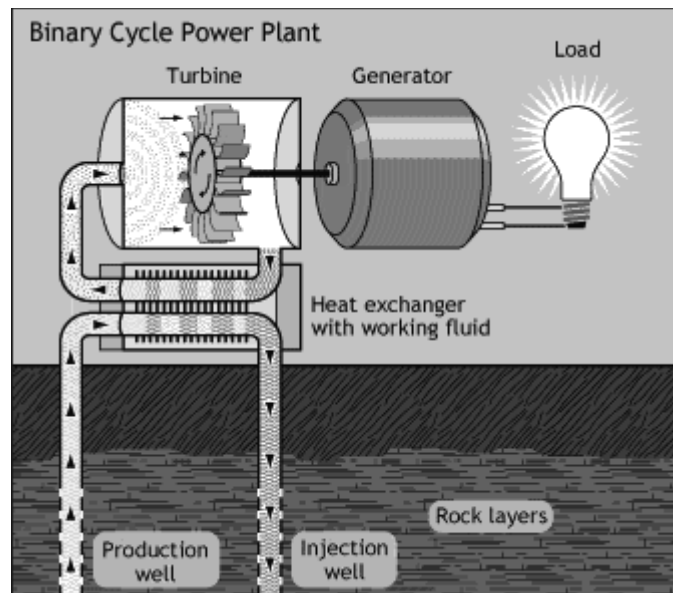

Figure 10-4. A Binary-Cycle Geothermal Power Plant (courtesy of U.S. Dept. of Energy)

power plants have considerably lower thermodynamic efficiencies than fossil or nuclear plants. Typical efficiencies are 10 to 20 percent.

Thermal power plants such as geothermal plants must provide some sort of cooling to condense the vapor leaving the turbine. The most efficient cooling means is with water, in which heat is transferred to water in a lake, river, or ocean, or to water that extracts heat by vaporizing in a cooling tower. Where sufficient water is unavailable, ambient air may be used to condense turbine exhaust, but air cooling is much less efficient. Consequently, the availability of water for the power plant as well as water for the makeup of lost water from the fracture zone is a factor in determining whether a geothermal power plant would be practical in a particular location.

10.7 Environmental Effects

Geothermal energy is usually considered to be pollution-free. Some gases (including carbon dioxide) contained in the rock formation may be brought to the surface with the heat transfer fluid. However, the release of gases into the atmosphere is so small compared to fossil power plant releases that the emissions are considered insignificant.

Since the power plant on the surface is small compared to the size of the subsurface reservoir, the impact of geothermal energy production on surface land is small. The small surface footprint makes it feasible to locate facilities where large conventional power plants would be unacceptable.

The main concern about the environmental effects of geothermal power plants is the possible need for water for condensing turbine exhaust and for makeup of any losses of the water injected into the underground formation. There is also some concern about stimulating seismic activity by the massive alteration of rock characteristics required for enhanced geothermal systems.

10.8 Heat Pumps

The basic idea of a heat pump is to use mechanical energy to extract heat from a cooler region and deposit it in a warmer region (see Appendix K). The heat pump drives heat in the opposite direction that it would flow naturally. A familiar example is a typical home refrigerator. It employs a compressor that uses the mechanical energy from a motor. The refrigerator pumps heat from its cool interior into warmer room air. (Heat pump applications are discussed in Section 15.3.3.)

A heat pump enables a space of interest to be warmed or cooled. The space that accepts heat in a cooling application or provides heat in a heating application is called a reservoir. In conventional heat pump applications, the reservoir is ambient air. However, heat extraction is more efficient when the reservoir is warmer, and heat deposition is more efficient when the reservoir is cooler. Unfortunately, ambient air is coolest when heat is most needed (winter) and warmest when cooling is most needed (summer).

Heat pump performance is enhanced when the reservoir temperature is lower than ambient air temperature in summer and higher in winter. These are exactly the conditions found in soil, rock, and groundwater located near the surface and in bodies of water. Tubes carrying refrigerant can be immersed in these regions to extract or deposit heat energy according to seasonal requirements. Doing this increases the initial cost of a heat pump installation but reduces subsequent energy costs.

To work effectively, the heat transfer tubes must be in good thermal contact with their surroundings. This means that heat can move readily between the heat exchange region and surrounding regions by conduction and/or water movement. If this condition is not met, the heat exchange region will cool down during heat extraction or heat up during heat deposition, and thereby lose its ability to supply or absorb heat.

10.9 Conclusions

Geothermal energy can be obtained from three sources: hydrothermal systems that possess desirable attributes naturally, enhanced geothermal systems that require deep drilling, hydrofracturing of rock, and supplying water for energy extraction, and geothermal heat pumps that use near-surface earth or water in lakes or rivers as a heat source or heat sink. Widespread use of geothermal heat pumps could contribute significantly to America's energy future if they become commonplace.

It is very tempting to say that the answer to our future energy supply problems lies beneath our feet. The geothermal energy source should be pursued vigorously, but the technical and economic challenges must not be minimized.

References

1. Kubrick, M. "The Future of Geothermal Energy" Massachusetts Institute of Technology Report, 2006. Available at <http://geothermal.inel.gov> (click "Publications," then find the document at "INL Reports").
2. Duffield, W. and Sass, J. H. "Geothermal Energy—Clean Power from the Earth's Heat" U.S. *Geological Survey Circular 1249*, 2003. Available at <http://pubs.usgs.gov/circ/2004/c1249/c1249.pdf>.
3. U.S. Department of Energy "An Evaluation of Enhanced Geothermal Systems Technology" (2008). Available at http://www1.eere.energy.gov/geothermal/pdfs/evaluation_egs_tech_2008.pdf.
4. Pollack, H. N., Hurter, S. J., and Johnson, J. R. "Heat Flow from the Earth's Interior: Analysis of the Global Data Set" *Rev. Geophys.*, Vol. 30, No 3. 1888 pp.267–280.
5. U.S. Geological Survey "Assessment of Moderate- and High-Temperature Geothermal Resources of the U.S." *USGS Fact Sheet 2008-3082* Available at <http://pubs.usgs.gov/fs/2008/3082>.

Exercises

- 10-1. Estimate the subterranean temperature at a depth of three miles.
- 10-2. How much thermal energy (BTUs and kilowatt-hours) is stored in a cubic mile of rock with a temperature of 600°F and recoverable by heat transfer to a medium at 100°F?
- 10-3. How many tons of rock must be accessed and fractured to extract one Quad of thermal energy by heat transfer to water that reduces the rock temperature by 400°F?
- 10-4. Use the Internet to discover the current state of enhanced (engineered) geothermal technology and application. Discuss your findings. Are you optimistic or pessimistic about the future potential of engineered geothermal systems? Explain your reasons.

11

Nuclear Energy

The Main Points

- Power reactors based on nuclear fission are well-developed and now produce around 20 percent of America's electricity.
- Future reactor implementation faces concerns about the possible release of radioactive materials from a reactor accident or the possible escape of radioactive materials from nuclear waste.
- The safety record of currently operating U.S. reactors is good.
- There was an accident at Three Mile Island in Pennsylvania in 1979 caused by operator error. There was damage but no health consequences. Nevertheless, the accident led to a hiatus in the construction of new plants in the United States.
- There was an accident at the Chernobyl plant in the Ukraine in 1986. The accident occurred because of a design flaw and operator actions. There were major releases of radioactive materials. Chernobyl-type reactors are no longer being built.
- There was an accident at the Fukushima Dai-ichi nuclear power plant in Japan in 2011 caused by a tsunami that destroyed the emergency cooling system. Radioactive material was released into the environment.
- New reactor designs improve safety and reduce cost.
- Countries could build nuclear weapons, but independent terrorists could not.
- The only environmental impact of a properly operated nuclear reactor is waste heat.

- **Uranium ore cost is a small component of nuclear power costs. Reactors could use large reserves of higher cost ore with little economic impact.**
- **Fusion reactors could produce essentially unlimited energy, but practical technology remains unavailable.**

11.1 Introduction

There is controversy about the capability and desirability of all energy supplies. Nuclear power tops the list in terms of the level of controversy. Nevertheless, nuclear power deserves to be considered for continued and expanded use because it is a non-polluting, economically competitive source of energy (and will be increasingly so if carbon emissions are taxed for fossil fuel plants in the future) that can be produced largely with U.S. domestic resources. Opponents of nuclear power think it is too expensive and/or they fear accidents at the power plants or the release to the environment of radioactive materials in the waste from nuclear plant operation. Those wishing to make an informed judgment about nuclear power must invest the time and effort required to understand the technical and economic issues.

11.2 Fission Reactors

Current (and near-term future) nuclear power plants employ the fission process, in which the nucleus of a heavy atom is split by a reaction with a neutron. The fuel used in this process is usually uranium, a rare, but economically recoverable material that is mined from the earth. The ore contains a mixture of two isotopes of uranium, 0.7 percent U235 and 99.3 percent U238. This naturally occurring mixture is called *natural uranium*. U235 is said to be fissile, meaning it readily undergoes fission. U238 can undergo fission when struck by a very high-energy neutron, but this is much less probable than fission in U235. U238 is said to be fissionable, but not fissile.

Most reactors require fuel with a higher percentage of U235 than occurs in natural uranium. A process called enrichment is used to increase the fraction of U235 in the mixture of uranium isotopes. Enrichment systems exploit the small mass differences between U235 and U238 to separate them. The currently favored method is gas centrifugation, in which a gas containing uranium is spun at a high rotational speed. The heavier material (U238) is thrown towards the outside of the spinning vessel (called a *centrifuge*). The gas near the center has a slightly increased concentration of U235.

A single centrifuge can yield only a small change in the relative amounts of U235 and U238 in the exit streams. Achieving significant changes in the relative concentrations requires a series of centrifuges (a cascade). Fuel for most nuclear power plants is enriched to U235 concentrations of 3 to 4 percent. (It should be noted that this enrichment level is inadequate for use in a nuclear weapon, for which almost pure U235 is required.)

It is possible to design a power reactor that can operate with natural uranium. This approach eliminates the need to enrich uranium. However, current natural uranium reactors require the use of heavy water as a moderator/coolant. (Later paragraphs will define the role of the moderator.) Heavy water (deuterium oxide) is a naturally-occurring, but very small, component of ordinary water. Deuterium is an isotope of hydrogen, differing from ordinary hydrogen by having a neutron as well as a proton in its nucleus. For use in a reactor, it must be separated from ordinary water. Thus, it is necessary to enrich water rather than uranium. The CANDU (Canadian Deuterium-Uranium) reactor is the only current power reactor design that uses natural uranium. CANDU reactors operate in Canada and other countries, but there are none in the United States.

A fission reaction yields the following products:

- Fission products. A fission reaction between an atom's nucleus and a neutron causes the atom to split into two or more smaller atoms. These fission products are radioactive. These, especially isotopes of strontium and cesium, create a radiation hazard in spent fuel.

- Neutrons. Two or three neutrons are produced in each fission reaction. The production of neutrons enables additional subsequent fission reactions and is the essential feature of a neutron chain reaction.
- Fission gamma rays (electromagnetic radiation released during fission).
- Energy. Energy appears because the total mass of the products resulting from fission is less than the total mass of the reactants (the nucleus that undergoes fission and a neutron). The amount of energy is given by Einstein's famous formula, $E=mc^2$, where m is the quantity of mass that is annihilated to produce energy. The energy appears as kinetic energy of the products (fission products and neutrons) and gamma ray energy.

In addition, non-fission neutron capture in uranium yields heavy elements called actinides. These materials, especially americium 241 and several isotopes of plutonium, contribute significantly to the radiation hazard in spent fuel, especially the long-term hazard.

The kinetic energy of the fission products and neutrons and the gamma ray energy degrade to heat energy as they interact with the materials in the reactor. This heat is usually used to make steam that drives a turbine in a power reactor. (Gas turbines can be used in gas-cooled reactors.) Steam may be produced by allowing water to boil in the reactor or by heating a liquid or gas stream in the reactor and subsequently using the heated liquid or gas to boil water in a heat exchanger called a steam generator.

A reactor must contain non-fuel materials such as structural material, coolant, moderator, metallic fuel cladding, and elements (such as oxygen) contained in compounds composing the fuel. All these materials absorb neutrons in a reactor. Since these non-fuel absorptions cause neither fissions nor conversion of fertile material into fissile material, a design objective is to minimize them by judicious selection of materials and arrangements.

The neutrons emitted in fission move at very high speed. Most reactor types include a moderator, a material that reduces the speed of the fission neutrons. Collisions between the neutrons and the moderator nuclei slow the neutrons without absorbing them strongly. (The exception is the fast breeder reactor in which the design favors fast neutrons.) The purpose of slowing the neutrons is that the probability of favorable events between neutrons and reactor core components (such as fission) is thereby increased relative to the probability of unfavorable events (such as non-fuel absorptions and leakage from the reactor). In those reactors that use either normal water or heavy water as a coolant, the coolant also serves as the moderator. Other reactor types employ a separate moderator material, such as graphite, in the reactor core.

A reactor may be designed in a way that causes temperature increases to slow the fission rate without requiring any actuation of the reactor control system. This feature, which greatly reduces the probability of an accident, is built into all U.S. reactors and will certainly be incorporated in future designs everywhere. (The Russian RBMK type of reactor did not have this feature, experienced an accident at the Chernobyl plant, and is no longer being built.) Control rods and safety shutdown rods provide control and safety shutdown capability. These rods contain strong neutron-absorbing materials. Insertion results in a reduction of the number of neutrons available for sustaining the chain reaction and slows or stops fission reactions.

Maintaining coolant flow even when the chain reaction shuts down is essential. Even after fission energy production ceases, the decay of radioactive material in the fuel continues to produce heat at a lower, but still significant, level. This energy, called *decay heat*, must be transferred to the coolant in order to prevent overheating and melting of core components. Reactors employ redundant emergency cooling systems to provide the coolant flow needed to remove decay heat. Nevertheless, emergency cooling failed when needed in the two accidents to date in light water reactors (Three Mile Island and Fukushima). Cooling is essential for the fuel rods in the reactor core. Cooling is also essential for the spent fuel rods that are stored in on-site pools until their level of radioactivity drops enough to permit dry storage.

The swarming neutrons and fission gamma rays, and the emissions from radioactive fission products, necessitate shielding of a power reactor. The spent fuel from a reactor contains fission products and actinides, some of which stay radioactive and harmful to humans for many years. They must be isolated and/or shielded to protect people from injury.

The U238, which constitutes 96 to 97 percent of the uranium loaded into most reactors (and 99 percent in CANDU reactors), also plays a role in plant operation. U238 can absorb neutrons, but only a small fraction of these absorptions results in fission. The great majority of the absorptions cause the U238 to be transformed into an isotope of plutonium, Pu239. Pu239, like U235, is readily capable of fissioning when struck by a neutron. That is, Pu239 is fissile. The production of useful Pu239 from useless U238 means there is a natural replenishment of useful fuel as the reactor operates. In a typical modern nuclear power reactor, about 40 Pu239 atoms are produced for every 100 fissions. Because U238 can be transformed into fissile Pu239, it is called a fertile material.

Nature also provides another potentially useful fertile material, thorium. Capture of a neutron by Th232 yields U233, a fissile isotope of uranium. Research reactors have been operated with thorium and U233. New thorium-U233 reactors, specifically molten salt reactors, are under consideration for future implementation. These reactors would permit exploiting the thorium resource in addition to the uranium resource for fueling reactors. It should be noted that starting a reactor that uses thorium requires blending the thorium with fissile material (U235 obtained by enrichment, Pu239 obtained from neutron capture in U238 in another reactor or U233 obtained from neutron capture in Th232 in another reactor).

It is even possible to build power reactors that produce more new fuel from fertile material than the fuel consumed. Recall that each fission reaction produces two or three neutrons. The average number of neutrons released is 2.5 or greater. One of these neutrons must cause a subsequent fission to maintain the chain reaction. This leaves at least 1.5 neutrons for capture in reactor materials or leakage from the reactor core. Judicious selection of reactor materials can result in one or more neutron captures in fertile mate-

rial per fission event, resulting in the production of new fissile material. The result is the creation of as much or more new fuel from fertile material as is being consumed in fission reactions. Such reactors, called breeder reactors, are more complex than current-generation reactors. Prototype breeder reactors have been built and operated, but have not yet proved competitive with traditional designs.

Breeder reactors that produce Pu239 from U238 require a fast neutron spectrum. That is, moderator materials that slow neutrons are not used. Breeder reactors that produce U233 from Th232 can be operated with slow neutrons. That is, moderator material, such as graphite, is used to slow neutrons.

Reactors must be refueled when the fissile material is depleted and/or the material properties of the fuel degrade. New fuel is added, and the old, highly radioactive fuel is removed. The fuel may be reprocessed to recover valuable fissile material or stored.

11.3 Safety

The controversy about nuclear safety revolves around the possibility of releasing radioactivity into the environment because of a reactor accident or an accidental release of radioactive material from nuclear waste.

11.3.1 Safety Principles

When abnormal, safety-related events occur in a reactor, the response must have two essential features. These are rapid reduction of power generation by fission reactions and continued cooling of the fuel rods to remove heat produced by the decay of radioactive components in the fuel. Fuel rods in the reactor core and spent fuel in storage pools produce decay heat and must be cooled to avoid melting and the release of radioisotopes into the environment.

Inserting safety rods that contain strong neutron absorbers will stop fission power generation very quickly, but not instantaneously. A small amount of fission power generation persists for several minutes before it becomes insignificant.

Decay heat from the radioisotopes in the fuel necessitates continued cooling after a reactor is shut down. The rate of decay heat release after shutdown depends on the inventory of radioisotopes in the fuel at the time of shutdown. This inventory depends on the fuel composition and the length of time that the reactor has operated, but typical heat release rates are 0.4 percent of the reactor power that prevailed before shutdown after one day and 0.2 percent after one week. 0.2 percent does not sound like much, but a typical large power reactor with a capacity of 1,000 electrical megawatts produces around 3,000 megawatts of heat. 0.2 percent of full power for such a system is 6 megawatts, or around 20 million BTU per hour. This is a significant amount of power, which must be removed to avoid overheating and melting.

Emergency cooling in current reactors requires the operation of pumps powered by grid electricity (if available) or Diesel generators or batteries if grid electricity is unavailable. Loss of all sources of pump power is catastrophic.

Failure to keep the fuel rods cooled can lead to overheating and melting of the fuel's metallic cladding. Molten metal can react with water, producing hydrogen, an explosion hazard. Overheating also raises the pressure inside the reactor vessel and piping. It is necessary to maintain tolerable pressure levels by cooling and/or venting.

The popular media sometimes explain the decay heat problem by analogy to the cool-down of a hot oven, but this analogy is false. When an oven is turned off, there is no longer any heat addition. Cooling simply takes place via transfer of the stored thermal energy to the air around the oven. When a reactor shuts down, there is also stored thermal energy, but, in addition, there is ongoing production of decay heat. Ongoing heat production after shutdown is the issue in a reactor.

11.3.2 Reactor Accidents

There was a catastrophic accident at the Chernobyl nuclear power plant in the Ukraine in 1986. Because of an undesirable design feature and inappropriate operation, the plant experienced a runaway power transient, fuel failure, fire in the graphite used as a moderator, and release of radioisotopes into the environment, which caused sickness and death among those affected. Anti-nuclear individuals cite the Chernobyl accident as proof that nuclear power is unacceptably dangerous. Pro-nuclear individuals contend that Chernobyl was an anomaly that occurred because of the poor design methods and weak safety standards used in the former Soviet Union.

The Chernobyl reactor had a “positive power coefficient.” This means a temperature increase following a power increase spontaneously and inherently causes an increase in the fission rate. Thus any power increase initiates further power increases unless constrained by operation of control action. This undesirable feature increases demands on the control system and increases the likelihood of a runaway chain reaction. Fortunately, nuclear engineers know conclusively how to design reactors with negative power coefficients. This means that a temperature increase following a power increase spontaneously and inherently causes a decrease in fission rates. Thus any power increase initiates subsequent power reductions, thereby stabilizing the reactor power. This feature reduces demands on the control system and eliminates the possibility of a runaway chain reaction. All reactors besides the Russian RBMK have negative power coefficients, and all future designs will certainly include this feature.

The design approach for U.S. reactors is to use multiple safety measures. The first is accident prevention by designing reactors to have inherent features that prevent or limit unsafe conditions (including negative power coefficients), by using redundant, highly reliable safety shutdown and cooling systems, and by requiring operating procedures that avoid safety challenges. Even though designers expect the accident prevention features to make accident probabilities vanishingly small, they incorporate containment as a second line of defense against the release of radioactive material. The fuel, its metallic sheath, and the reactor vessel and piping are designed

to contain the fuel and fission products. Finally, the whole system is contained in a reinforced concrete structure that is designed to hold the radioactive materials should they escape from the vessel and piping.

The accident at Three Mile Island in 1979 occurred because workers ignored required procedures and operated the system improperly. The bad news was that cooling was lost, fuel melted, and radioactive materials escaped from the vessel and piping into the containment structure. The good news was the containment structure prevented gross release of radioactive material into the environment, though a small amount of radioactive gas was vented to the atmosphere. Three Mile Island was an event with major financial impact on its owner, but no direct impact on public health. (Some people may have experienced emotional illness because of the stress associated with the accident.) Three Mile Island revealed the crucial importance of safe operating procedures and adherence to those procedures. Nuclear power plants now operate under strict procedural rules, but, of course, continued vigilance is essential.

In March 2011, there was an accident at the Fukushima Dai-ichi plant in northeast Japan. The plant has six boiling water reactors. There was a massive earthquake in the ocean east of the plant. The reactor shutdown systems worked properly following the earthquake, stopping the fission reaction in all of the units that were operating. A few minutes later, a tsunami hit the plant, cutting access to off-site electrical power and wiping out the emergency cooling system. (The emergency power supplies were located where they were vulnerable to destruction by tsunami waves. Given the prior knowledge that the region was susceptible to tsunamis, this must be viewed as a major design error.) Decay heat and the loss of cooling ability led to fuel overheating, fuel melting, hydrogen production by metal-water reactions, hydrogen explosions, and the release of radioactive material. The Fukushima accident brings new uncertainty into the future of nuclear power. (In May 2011, Germany announced that it will shut down all of its nuclear plants.)

11.3.3 Radioactive Waste

The safety of radioactive waste is the second concern in the controversy over nuclear power safety. The waste is highly radioactive and very dangerous. However, the waste volume is small enough to make it feasible to implement extremely conservative handling procedures. For example, a typical large pressurized water reactor contains 193 fuel bundles in a reactor core that is 10 feet tall and 14.4 feet in diameter. The core volume is 1,628 cubic feet. The reactor is refueled every 18 to 24 months, with one-third of the fuel replaced with new fuel bundles at each refueling. So the volume of spent fuel removed at refueling occupies around 543 cubic feet. The volume of spent fuel is thus 272 to 362 cubic feet per year, depending on the frequency of refueling. The footprint of the spent fuel bundles (each 10 feet tall) is only 27 to 36 square feet per year. (This area is comparable to the floor area of a small closet.) Of course, a larger total footprint is required to provide cooling and shielding of the stored spent fuel, but it is clear the volume of spent fuel produced every year is quite small.

Reactor fuel cycles may be a once-through process, in which the spent fuel is stored, or a closed cycle process in which plutonium and uranium are separated from the spent fuel and mixed with new uranium or thorium for further use as fuel. Materials for recycling may also include fission products and actinides, which are included so they can be transformed into less dangerous elements by absorbing neutrons. Studies have evaluated the benefits of partitioning the fuel into streams composed of selected elements and then transmuting these elements by further exposure to neutrons. The transmuted elements have lower radioactivity and lower heat generation, thereby reducing design requirements for disposal facilities. Of course the separation and transmutation operations require special facilities and procedures. There is a trade-off between the cost of separation and transmutation and the benefits to disposal facilities. The current plan for waste handling in the U.S. is the once-through approach. Some other countries use the closed cycle process, and it is a possibility for future U.S. use.

The once-through fuel cycle uses a three-step approach. The first step involves storing the spent fuel in water-filled pools and, after adequate

decay of the radioactive materials, in dry, shielded casks at the reactor site. During this step, most of the radioactivity dies off. The second step is transporting the spent fuel to a waste repository. Special high-strength containers will be used. (Anti-nuclear individuals feel that transporting nuclear material is too risky, regardless of the strength of the container. Pro-nuclear individuals say the containers are so over-designed that releases during transport are simply implausible.) The third step is burial in a waste repository. A repository for permanent storage of nuclear waste has one overriding design requirement: it must be highly improbable that isolation of the radioactive materials will ever be breached by human activity or natural causes. Human activities of concern for buried waste are mining and drilling. Natural causes of concern are contact with ground water, earthquakes, and volcanoes.

However, because there is currently no operating repository in the United States, only the first step in the once-through fuel cycle (on-site storage) is being practiced. A permanent repository site was selected at Yucca Mountain in Nevada. The Yucca Mountain facility has been under construction and testing for many years. Its originally scheduled opening date passed long ago, but Yucca Mountain's opening date is still indefinite, and it is not certain that it will ever open. (The Obama administration canceled work on Yucca Mountain. Whether this ruling will be reversed in the future is unknown.) On-site storage of spent fuel at reactor sites provides an acceptable short-term approach. Eventually there must be a permanent U.S. repository for the spent fuel.

In the closed-cycle approach, fuel is also kept at the reactor site until most of the radioactivity has died away. The second step is to transfer the spent fuel to a reprocessing facility. This step raises the same issues as fuel transport in the once-through fuel cycle if the reprocessing facility is located away from the reactor site. At the reprocessing facility, the fuel material is chemically separated into two streams, a waste stream and a recycle stream. The waste stream is sent to a permanent storage facility. The recycle material is mixed with fresh uranium or thorium. Since the recycle fuel in current reactors is in the form of oxides of uranium and plutonium, it is called mixed oxide, or MOX, fuel.

There is disagreement among experts on whether the once-through or the closed cycle approach is superior.^{1,2}

11.3.4 Accidents and Liability

The risk associated with nuclear power is a pervasive question for the nuclear utilities, the nuclear regulators, and the public. A method called probabilistic risk analysis (PRA) was developed to address the quantitative assessment of risk in nuclear power generation and other activities.

Accident risk is usually characterized by estimates of the probability that an accident will occur versus the consequences of that accident: illness and loss of human life, property damage, and rendering land unsuitable for human activities. In a PRA, the analyst attempts to identify all plausible accident scenarios, the probability that such an accident will occur and the consequences if the accident does occur. This undertaking is very complex. It is impossible to ensure every possible accident is included. Nevertheless, a carefully performed PRA provides a useful picture of the relative risk associated with various activities, even though the numerical results are subject to significant uncertainty.

Risk associated with large consequences is acceptable only if the probability of occurrence of an accident is low, and risk associated with accidents with a high probability of occurrence is acceptable only if the consequences are low. For example, history tells us that we can expect several major airline crashes per year, and the usual consequence is the loss of several hundred lives. The continued growth of air travel indicates that most people conclude that the risk is acceptable.

Probabilistic risk assessment finds that nuclear accidents have potentially large consequences, but accidents with extremely severe consequences have a low probability of occurrence. Of course accidents with less severe consequences are found to have a higher probability of occurrence. Also, it should be noted that an event having a low probability of occurrence does not mean that the event cannot occur. Any event with a non-zero probabil-

ity can occur at any time. A low probability of an event only means that few events are likely in some time interval.

The possibility of accidents with large consequences raises questions about liability. If the worst possible nuclear accident were to occur, the financial liability would exceed the ability of any individual utility or insurance company to pay. The U.S. government has acted to help manage the liability for losses associated with a nuclear accident through the Price Anderson Act, which was enacted in 1957 and has been extended and revised several times since. The 2005 version (set to expire in 2025) has three main features:

- Owners of individual nuclear facilities must buy insurance to cover liabilities of up to \$300 million.
- To provide for liabilities exceeding \$300 million, all owners of nuclear facilities must contribute up to \$111.9 million each to a fund to be used for compensation if, and when, losses occur. In 2011, the commitment for 104 nuclear power plants was \$12.2 billion.
- If claims exceed the funds available from insurance and the industry fund, Congress can either increase the liability of the nuclear industry or provide federal funds.

This program, like other issues related to nuclear power, is controversial. Critics say the Price Anderson Act is an unfair subsidy for nuclear power. Proponents say the Act is a wise, low-risk government policy that supports an industry that operates for the good of the country.

11.4 Energy Costs and Environmental Impacts

Cost and environmental impact, as well as safety considerations, will dictate the future role of nuclear power. Costs consist of capital costs and operating costs. Capital costs are the ongoing debt service of the money borrowed to build the facility. Operating costs are the ongoing costs for fuel, mainte-

nance, repairs, etc. In a nuclear plant, the capital costs are a much larger fraction of total power costs than in fossil fuel plants. Since capital costs persist whether the plant is operating or idle, it is desirable to run a nuclear power plant at full power as much as possible. Plants that operate at constant power are called base-load plants. Of course, other plants in the system must change power levels continuously in response to changing power demands in the electrical grid. These plants are called load-following plants. The need for adequate load-following capability influences the required ratio of load-following plants to base-load plants in a system. There must be enough load-following plants to handle any demand changes experienced by the system. Therefore, the number of base-load nuclear plants in a system is constrained by load-following considerations.

The average cost of electricity currently produced in U.S. nuclear plants is 3 to 5 cents per kilowatt-hour. Experts predict future costs of nuclear electricity. Predicted costs in two recent publications are 2 to 12 cents per kilowatt-hour³ and 4.2 to 6.7 cents per kilowatt-hour⁴. The range of values in these estimates reflects the uncertainty in predictions of future costs.

Capital costs account for over 50 percent of nuclear energy cost, fuel accounts for around 19 percent, and operation and maintenance account for the rest. Fuel cost includes ore cost, processing cost, enrichment cost, and fabrication cost. Ore cost contributes only about 5 percent to total power cost. Since nuclear electricity costs are quite insensitive to the price of ore, the penalty for the use of lower grade and higher cost ore is a small contributor to total energy cost. Lower grade ores expand the uranium resource for use in nuclear plants.

The environmental impact of a properly operated nuclear power plant consists entirely of the waste heat dumped into the atmosphere or into bodies of water. There are no gaseous emissions, so there is no contribution to the greenhouse effect.

11.5 Proliferation

There is concern that the widespread use of nuclear power will increase the likelihood of acquisition of materials for weapons by rogue states or terrorists. A nuclear weapon requires almost pure U235 or Pu239. Pure U235 can be obtained only by enriching a U235-U238 mixture. Power reactor fuel enrichment is no more than 4 percent. Consequently, weapons material requires enrichment, whether starting with natural uranium (0.7 percent U235) or reactor fuel (4 percent U235). Diversion of reactor fuel to obtain raw material for enrichment to weapons grade is not a viable option for terrorists because enrichment facilities are too large, too expensive, and too hard to conceal.

Spent reactor fuel contains Pu239 as a result of neutron captures in U238. Pu239, like U235, is suitable for making a nuclear weapon. Plutonium can be separated from other materials in the spent fuel by chemical processing, so enrichment is not required. However, the chemical processing requires special heavily shielded facilities, and, furthermore, the plutonium contains other plutonium isotopes besides Pu239. These isotopes decrease the potential of the plutonium from spent fuel for use as weapons material. Obtaining weapons-grade plutonium from spent fuel is also not a viable option for terrorists.

The overall conclusion is that power reactors do not provide a viable means for illegal and clandestine acquisition of weapons material. The real concern is that highly concentrated radioactive waste material might be stolen and mixed with conventional explosives to make a so-called “dirty bomb.” However, this too requires that perpetrators have the shielded facilities required to handle the radioactive material.

Of course, sovereign countries can choose to develop nuclear weapons. The major nuclear powers (the United States, Russia, the United Kingdom, France, and China) generally discourage development of nuclear weapons by other countries and encourage the signing of non-proliferation agreements. Nevertheless, some nations have undertaken weapons development programs. Most have canceled their programs, but some have successfully

developed weapons (India, Pakistan, Israel, and North Korea). There is continued concern that nations with nuclear weapons will use them if they come under the control of an aggressive leader or if they become desperate in a war. There is also concern that poor, but nuclear-capable countries will sell weapons to terrorists. Monitoring, diplomacy, and sanctions are means by which limitations are placed on countries with nuclear weapons capabilities or ambitions. There is also the possibility of the use of military force to halt a nuclear weapons development program.

11.6 Reactor Design Evolution

Because of the controversy about the use of nuclear energy, it is important to understand how the nuclear power industry evolved as well as the technology on which it is based. Lessons learned from the past should help guide future decisions about nuclear power in the United States.

The evolution of commercial nuclear power is often described in terms of different generations, each characterized by the dominant reactor designs for that generation. Reactors currently being built in some parts of the world are Generation III designs. Work is under way on future designs that constitute Generation IV. Generation V systems are radically new, highly speculative designs that are being investigated for possible use in the distant future.

11.6.1 Generation I Reactors

The first nuclear reactor, designed by Enrico Fermi and built at the University of Chicago in 1942, served to demonstrate the feasibility of operating a system based on uranium fission (see Figure 11-1). The success of the “Chicago Pile” led to the construction of reactors in Oak Ridge, Tenn., and Hanford, Wash., whose purpose was to produce Pu239 for nuclear bombs by transforming U238 into Pu239 by neutron capture. Additional reactors for producing weapons material were subsequently built at the Savannah River Site near Aiken, S.C.



Figure 11-1. The Chicago Pile (courtesy of U.S. Dept. of Energy)

Following the initial focus on producing a nuclear bomb, interest developed in using nuclear fission reactors to produce useful energy. The U.S. government, through the Atomic Energy Commission, embarked on a reactor development program. The first nuclear electricity in the U.S. was produced with a small generator and used to power a light bulb at the Experimental Breeder Reactor, EBR-1, in Arco, Idaho in 1951. In 1954, the U.S. Congress removed the ban on nuclear activities by non-government organizations.

The first successful application of a nuclear reactor for energy production was military: the propulsion plant for the USS *Nautilus*, a submarine commissioned in 1955. The *Nautilus* used a pressurized water reactor supplied by Westinghouse to the Navy. The success of the *Nautilus* led to the construction and operation of the first U.S. land-based power reactor, the Shippingport 60 MW reactor in Pennsylvania, commissioned in 1957. Shippingport was the prototype of the large pressurized water reactors that were built subsequently in the U.S. and other countries. Another power reactor that was to be the prototype of large-scale commercial reactor sys-

tems was the 200 MW Dresden boiling water reactor, commissioned in Illinois in 1960.

Pressurized water reactors (PWRs) and boiling water reactors (BWRs) became the dominant types to be built in a massive power reactor construction boom in the U.S. and several other countries in the 1960s and 1970s. However, in the late 1950s and early 1960s, many different reactor types were considered for development into commercial systems. This included sodium cooled fast reactors, gas-cooled reactors, sodium-graphite reactors, aqueous homogeneous reactors, molten salt reactors, and organic moderated reactors. Much time and money was consumed in designing and building prototypes of all of these reactor types, but eventually all were abandoned in the U.S. (though China is building gas-cooled reactors, and some other types are still candidates for future implementation in the U.S. and elsewhere).

Reactors built in the early years (through the early 1960s) are usually referred to as Generation I reactors.

11.6.2 Generation II Reactors

Generation II reactors are the large commercial reactors (typified by PWRs and BWRs) built in the U.S. and elsewhere in the 1960s and 1970s. Most of these reactors are still operating and are producing about 20 percent of America's electricity. Power reactors were built by four U.S. companies for operation by utility companies. Westinghouse, Combustion Engineering, and Babcock and Wilcox offered pressurized water reactors (PWRs), and General Electric offered boiling water reactors (BWRs). Over 100 plants, some capable of delivering over 1000 megawatts of electricity, were built in the United States. In retrospect, it is amazing that nuclear power went from jubilation at powering a light bulb in 1951 to supplying 20 percent of America's electricity in about 25 years. It is now clear that in this rapid deployment, great strides were made, but some seeds of future problems were also planted.

Pressurized water reactors were built in greater numbers in the U.S. than boiling water reactors. Figure 11-2 shows the main components of a PWR. The uranium, in the form of uranium oxide pellets, is contained in tubes made of a zirconium alloy. These fuel rods are assembled into bundles for installing in the reactor. Water flows through the reactor and around the fuel rods to extract the heat from the fuel. The maximum water temperature is around 625°F (330°C), and the pressure is around 2200 pounds per square inch (152 bar). The heated water passes through piping into tubes inside the steam generator before returning to the reactor via piping. A second stream of water flows around the outside of the tubes of the steam generator where boiling occurs. The resulting steam flows to a turbine that drives an electrical generator. Exhaust steam from the turbine passes through a condenser and a series of reheaters before re-entering the steam generator. The reactor coolant loop (the primary loop) and the secondary loop are closed systems. There is no contact between the water in the separate loops. Control and safety rods enter empty spaces in the fuel bundles from above. The reactor coolant loop (the primary loop) and the secondary loop are closed systems. There is no contact between the water in the separate loops. Control and safety rods enter empty spaces in the fuel bundles from above.

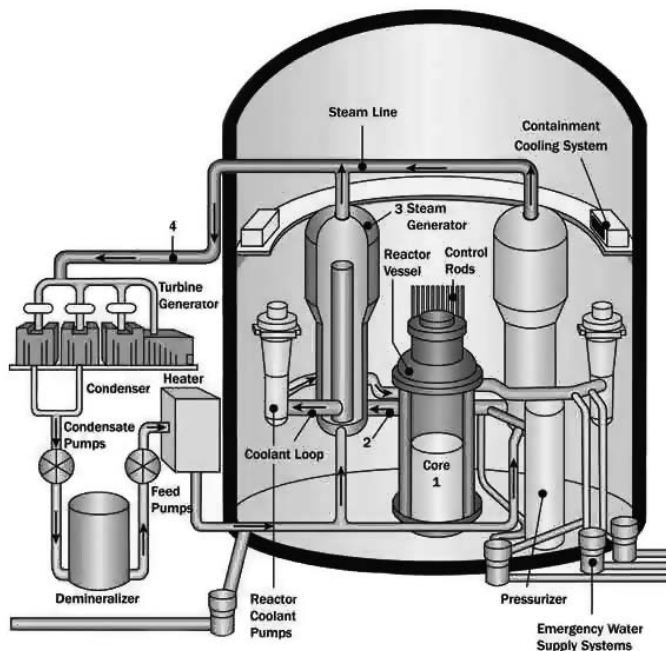

Figure 11-2. A Pressurized Water Reactor
(courtesy of U.S. Nuclear Regulatory Commission)

A number of boiling water reactors were also built in the United States. The main components of a BWR are shown in Figure 11-3. As in PWRs, uranium oxide pellets are stacked inside zirconium alloy tubes that are assembled into bundles. Water flows through the reactor to extract heat from the fuel rods as in a PWR, but in a BWR, the water boils inside the reactor core. The maximum water temperature is around 515°F (268°C), and the pressure is around 1,100 pounds per square inch (76 bar). The steam produced passes directly to a turbine. Exhaust steam from the turbine passes through a condenser and a series of reheaters before returning to the reactor vessel. Hydraulically-driven control and safety rods enter empty spaces in the fuel bundles from below.

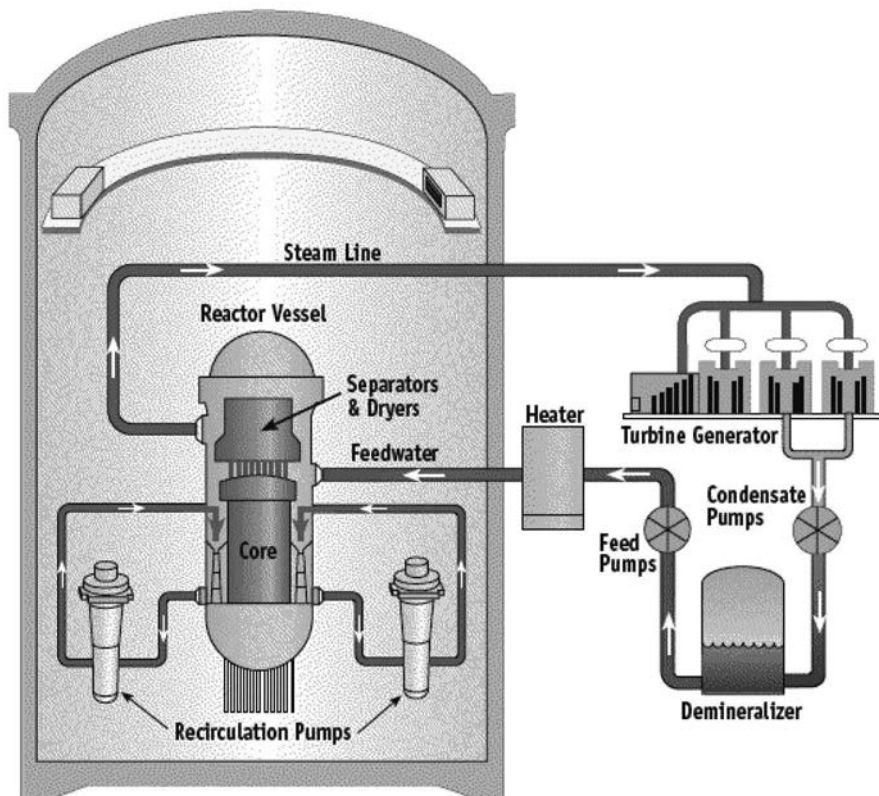

Figure 11-3. A Boiling Water Reactor (courtesy of U.S. Dept. of Energy)

PWRs and BWRs are designated as light water reactors (LWRs) to distinguish them from reactors that use other coolants.

Other power reactor types were developed and deployed in other countries. These include:

- CANDU: Canada developed the CANDU reactor, which uses natural uranium fuel and heavy water as a coolant and moderator.
- GCR: Gas-cooled reactors using carbon dioxide or helium coolant and graphite moderator have been built and operated, mostly in Britain and, more recently, in China.
- FBR: Several sodium-cooled fast breeder reactors have been operated, though their mission has been more to test the concept than to provide competitive electricity.
- VVER: This is the Russian version of the PWR. It has similarities and some significant differences from western PWRs.
- RBMK: The RBMK is a graphite-moderated, water cooled reactor of Russian design. It is known to have severe stability problems, which unfortunately manifested themselves in the Chernobyl accident. RBMK reactors are no longer being built.

In the rush to build U.S. power reactors, there was little focus on standardization. Not only did the four suppliers provide different designs, each vendor supplied custom designs to suit specific customers. It went so far that concerns about a possible design-specific problem that might cause regulators to shut down all of the reactors led to the construction of reactors from different vendors on a single site. This lack of standardization caused longer and more costly construction, longer and more costly regulatory review, fewer benefits of experience shared between operators of a reactor type, restrictions on staff transferability, and increased spare parts inventory requirements. The result was more expensive, less reliable, and less safe plants than would have occurred with standardization.

One might also argue that the nuclear industry demonstrated excessive hubris during the rapid deployment of large power reactors. Certainly, there was too little emphasis on training of reactor personnel, too few restrictions on operating procedures as needed to enhance safety, too little emphasis on safe and effective maintenance, and too little oversight. These factors contributed to the accident at the Three Mile Island PWR in 1979. Basically, operators performing work on a reactor subsystem ignored written procedures and caused a loss of coolant to the reactor core, with subsequent partial melting of the fuel. Operator error (exacerbated by poor reactor design) also caused the Chernobyl accident in The Ukraine in 1986.

All new power reactor construction in the U.S. stopped after Three Mile Island. Major new efforts have focused on improving the safety and reliability of existing reactors. Just as it appeared that a rebirth of nuclear power was about to begin, the Fukushima accident occurred. This event will certainly stall new reactor construction, at least temporarily. Nevertheless, work has started in the U.S. on completion of several reactors for which work was previously suspended, and construction of several new reactors has been approved.

11.6.3 Generation III Reactors

New designs, called Generation III reactors, have been developed. They are evolutionary improvements over Generation II reactors. Features of Generation III reactors include:

- Standardized designs that expedite licensing, reduce capital cost, and reduce construction time
- Passive safety features that reduce the need for the actuation and proper operation of engineered safety systems
- Longer intervals between refueling achieved by the use of higher fuel enrichment and burnable poisons (materials that absorb neutrons, but whose strength declines along with fuel consumption)

- Ability to operate with mixed oxide fuels
- Simpler designs that expedite construction and operation

Designs under consideration for Generation III include small and medium power plants. This is a major departure from the Generation II preference for large reactors with capacities of 1,000 megawatts or greater. The small and medium plants have generation capacity of less than 700 megawatts. The designs focus on the simplifications and safety enhancements that are possible with smaller sizes. Small and medium plants can employ greater shop fabrication and delivery of components to the plant site instead of the extensive on-site fabrication used for Generation II reactors. The plants have lower inventories of radioisotopes and are easier to cool in the event of an accident.

The number of reactor vendors has grown since the Generation II era. Companies have left the nuclear reactor business, companies have merged, companies have been bought by other companies, and new companies have appeared. This growth has good features and bad features. The good part is that competition will drive each vendor to make a better product. The bad part is that though each vendor might offer a standardized design, there is no standardization between vendors, causing concern about the possible recurrence of Generation II problems if several vendors compete in the same market.

11.6.4 Generation IV Reactors

Work is under way to develop reactor designs for possible construction in the future. Currently, six concepts are under consideration. The objective is to achieve improved safety, improved proliferation resistance, reduced waste, and reduced cost. Generation IV reactor designs provide higher temperature operation than current designs. Higher temperatures can enable higher thermodynamic efficiencies in electricity production and can provide process heat for processes such as the high-temperature electrolysis of water to produce hydrogen. The designs under consideration include new concepts and the resurrection of some older concepts that previously failed

to reach commercialization. The plan is to have the designs ready for implementation around the end of the first quarter of the twenty-first century.

The Generation IV reactor concepts currently under consideration are:

- Very High Temperature Reactor (VHTR): The VHTR uses helium coolant that flows through a core consisting of graphite impregnated with fuel particles.
- Supercritical Water-Cooled Reactor (SCWR): The SCWR is an outgrowth of current light water designs. It operates at much higher temperatures and pressures than current light water reactors.
- Molten-Salt Reactor (MSR): The MSR is a fluid-fuel reactor. Fuel is dissolved in a molten salt that flows through a graphite core. The MSR concept permits continuous processing to remove fission products and add fresh fuel, but this is accomplished at the cost of complex plumbing and materials handling.
- Gas-Cooled Fast Reactor (GCR): The GCR is a breeder reactor that uses helium gas to carry the heat from fuel elements comprising the reactor core.
- Sodium-Cooled Fast Reactor (SFR): The SFR is a breeder reactor that uses liquid sodium to carry heat from fuel elements comprising the reactor core.
- Lead-Cooled Fast Reactor (LFR): The LFR is a breeder reactor that uses liquid lead to carry heat from fuel elements comprising the reactor core.

A successful Generation IV program must avoid the mistakes of the past. There will be trade-offs between giving each concept a fair chance and avoiding wasting money on concepts with little or no potential for commercialization.

11.6.5 Generation V Reactors

Generation V reactors are speculative concepts that may be suitable as successors to Generation IV systems. It is too early to identify leading candidates, their technical feasibility, or their economic competitiveness. It will be many decades before Generation V deserves or receives serious consideration.

11.7 Nuclear Fuel Supply

Like fossil fuel, uranium needed to fuel nuclear reactors is a finite resource that must be extracted from the earth or the seas. Unlike energy production with fossil fuels, energy production with uranium is quite insensitive to raw material cost. The expenditure for uranium ore is responsible for only about 5 percent of total energy cost for a nuclear power plant.

The World Nuclear Association⁵ reports that in 2009, the U.S. had 0.2 million metric tons of remaining uranium that is recoverable for \$130 per kilogram (\$60 per pound) or less. The estimate for the world resource is 5.4 million metric tons for \$130 per kilogram or less. Reserve estimates change periodically as new information becomes available, but these figures give a picture of the resource.

The uranium requirement in a current reactor with an output of 1,000 electrical megawatts is around 200 metric tons of natural uranium per year. Estimated U.S. reserves will support 1,000 reactor years of operation, and world reserves will support 27,000 reactor years (based on ore costing no more than \$130 per kilogram and 1000 MWe reactors). Current nuclear power reactors in the U.S. produce power at a rate of about 100,000 MWe, requiring about 20,000 metric tons of natural uranium per year. It is known that huge amounts of lower grade uranium ores exist. These reserves could increase nuclear energy capacity manyfold with small increases in energy cost.

Reducing the quantity of uranium needed is achievable with closed cycle operation and/or the use of breeder reactors. These approaches would also result in a manyfold increase in nuclear energy capacity.

Resource availability is a factor in decisions about future deployment of nuclear power reactors, but because of the small contribution of ore cost to total power cost, it is not a limiting factor.

Obtaining uranium ore requires mining and milling operations performed with special precautions. Uranium ore contains radioactive radon gas as well as uranium. Radon exposures during mining operations are known to result in health problems. Careful ventilation is now used to minimize exposures to miners. Also, residues from the mining and milling operations contain radon and other radioactive materials that must be isolated from the environment. Government regulations now specify requirements for miner safety and for safe disposition of mining and milling residues.

11.8 Fusion

Fusion energy, like fission energy, relies on a process in which mass is converted into energy according to Einstein's famous formula, $E=mc^2$. In the fission process, heavy nuclei break apart upon reacting with a neutron, producing lighter nuclei whose collective mass is less than the combined mass of the fissile nucleus and the neutron. In the fusion process, two light nuclei join together to produce a heavier nucleus whose mass is less than the collective masses of the two reacting nuclei.

When fissile material and neutrons are brought together, fission proceeds readily. Fusion, however, is a different story. Since the nuclei in a fusion reaction are both positively charged, they repel one another. For a fusion reaction to occur, the reacting nuclei must overcome the repulsive force. One way to overcome the repulsive force is to heat the reacting nuclei to give them adequate kinetic energy. The required temperatures are in the millions of degrees. At these temperatures, the reacting materials are in the fully ionized, or plasma, state.

The light materials suitable for undergoing fusion are deuterium (D), tritium (T) and helium-3 (^3He). All of these are isotopes of common materials. Deuterium is an isotope of hydrogen, and it occurs naturally in ordinary hydrogen. Ordinary hydrogen consists of one part deuterium to 6,700 parts hydrogen. Hydrogen has one proton in its nucleus. Deuterium has one proton and one neutron. Tritium, with one proton and two neutrons, does not occur in nature, but it can be produced with appropriate nuclear reactions. Tritium can be produced by a reaction between a neutron and lithium-6, a naturally-occurring isotope of lithium. Helium-3 is an isotope of helium that does not occur naturally and is difficult to produce.

The fusion reactions are:



and

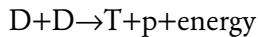

(Both reactions have equal probability.)

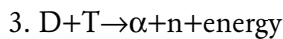
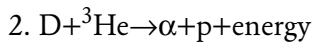

where

n = neutron

p = proton

α = alpha particle

The D, D and D, ^3He reactions are less favorable than the D, T reaction because the D, D reaction suffers from low reaction probabilities, and the D, ^3He reaction suffers because of the unavailability of ^3He . The D, T reaction is the most attractive, but it requires a supply of tritium. Fortunately,

tritium can be produced in-situ by capturing neutrons from the D, T reaction in a lithium blanket around the reactor volume.

Two types of fusion device are under development: the magnetic fusion reactor and the inertial fusion reactor.

In the magnetic fusion reactor, the idea is to contain the plasma using magnetic force to “bottle” the high-energy nuclei. A magnetic fusion reactor based on the D, T reaction would consist of a high temperature reaction zone surrounded by a lithium blanket used to produce the necessary tritium with leakage neutrons from the reaction zone. A superconducting magnet around the blanket keeps the nuclei from leaving the reaction zone. Among the numerous engineering challenges in a magnetic fusion reactor are achieving material properties suitable for withstanding high temperature and high radiation, achieving a magnetic force field that properly contains the plasma, and extracting energy from the fusion reactor for useful purposes. Great progress has been made in understanding the science, but a device that produces more energy than it consumes has not yet been built.

In an inertial fusion device, the idea is to induce high temperatures and high reactant densities by bombarding small fuel pellets with a high energy laser or particle beam. This compresses and heats the pellet, thereby overcoming the repulsive forces between atoms. Each pellet acts like a small fusion bomblet. Rapid pellet injections and implosions produce continuous power.

11.9 Nuclear Energy in the Future

Previous sections have given a brief overview of nuclear energy and the main issues relevant to future deployment. It is clear that nuclear technology is capable of displacing significant quantities of fossil fuel used for generating electricity. Most, if not all, of the resources for building and operating nuclear power plants are available domestically in the United States. Whether this capability is used depends on allaying safety concerns, allaying proliferation concerns, and achieving economic competitiveness.

The 2011 accident at Fukushima certainly increased concerns about reactor safety and reduces the prospects for a return to growth in nuclear power, but it must be remembered that every energy source has its own drawbacks.

References

1. Ansolabehere, S. et al. "The Future of Nuclear Power" an Interdisciplinary MIT Study. The Massachusetts Institute of Technology, 2003 (accessed at <http://www.mit.edu/afs/athena/org/n/nuclearpower>).
2. Miller, L.F. et al. "Sustainable Production of Power Using Nuclear and Alternative Energy for Tennessee Valley Authority" Department of Nuclear Engineering, the University of Tennessee, April 2005.
3. Kammen, D. M. "The Rise of Renewable Energy" *Scientific American* Vol. 295, Number 3, September 2006 pp. 84–93.
4. Tester, J. W. et al. "Sustainable Energy" Cambridge: MIT Press, 2005.
5. World Nuclear Association, "Supply of Uranium" at <http://www.world-nuclear.org/info/inf75.html>.

Exercises

- 11-1. Nuclear energy results from the conversion of mass into energy. How does this relate to the principle of conservation of energy?
- 11-2. According to Einstein, the energy released during conversion of mass into energy is given by $E=mc^2$ where E = energy (in ergs) released, m = mass (in grams) annihilated, and c = speed of light = 3.1×10^{10} cm per second. Calculate the energy released by annihilation of one gram of matter. Express the result in ergs, BTUs, and kilowatt-hours. (Note: 1 kilowatt-hour = 3.6×10^{13} ergs.)
- 11-3. One watt of power is produced by 3.1×10^{10} fissions per second. How many atoms of fissile material must be consumed per second

to produce one megawatt? How many grams of U235? (Note: there are 1.42×10^{26} atoms per gram of U235.)

- 11-4. When this book was written, the Yucca Mountain facility had been canceled, and there was no facility for permanent storage of nuclear waste. Use the Internet to find the current status of plans and facilities for permanent disposal.
- 11-5. Nuclear power plants produced about 20 percent of America's electricity in the early twenty-first century. If the energy from nuclear plants had been produced in coal-burning plants, how much carbon dioxide would have been released into the atmosphere per year? How significant is this?
- 11-6. The Fukushima nuclear plant accident in Japan occurred during the preparation of this book. What is the current estimate of the consequences (health effects, financial loss, property damage)? What effect has it had on plans for new nuclear plants in the U.S.?
- 11-7. Why did the safety system fail at Fukushima? Was the failure due to a design flaw or operator error?

12

Hydrogen

The Main Points

- **Hydrogen is not an energy resource, but an energy carrier.**
- **Like electricity, the other main energy carrier, hydrogen must be manufactured.**
- **Like electricity, much more energy must be used to make hydrogen than can be produced by using the hydrogen.**
- **Hydrogen can be made from a number of hydrogen-bearing compounds, but any large-scale future hydrogen production will be based on the electrolysis of water.**
- **Hydrogen is difficult to store and transport.**
- **Batteries use energy much more efficiently than hydrogen fuel cells.**

12.1 Introduction

Hydrogen can serve as a fuel, but it, like electricity, is an energy carrier rather than an energy resource. That is, hydrogen must be produced from another material, and this production requires more energy than is contained in the hydrogen produced. Hydrogen can be stored in bulk for use when needed, albeit at significant difficulty and expense. Electricity, on the other hand, cannot be stored except for limited quantities in capacitors. (Some say that batteries store electricity, but, in fact, they store chemical energy that can readily be converted into electricity.)

Hydrogen reacts strongly with other chemicals to form compounds. As a result, hydrogen desired for use as a fuel is locked in hydrogen-bearing compounds. Source materials for producing free hydrogen are water, hydrocarbons, and biomass. Obtaining free hydrogen for use as a fuel requires extracting it from these materials and this extraction requires an expenditure

of energy that exceeds the energy subsequently available from the use of hydrogen as a fuel.

The rationale for expending energy to create a new fuel material is to produce a new fuel with greater usefulness. This rationale is analogous to using heat from fossil fuel combustion or nuclear fission to produce electricity, which wastes about two-thirds of the energy released. However, the electricity produced is so uniquely useful that this waste is freely tolerated. Likewise, if using hydrogen as a fuel is to become commonplace, it will require that its usefulness is found to outweigh the problems and costs associated with producing, storing, transporting, and using it.

There has been great enthusiasm for a “hydrogen economy” among many advocates of a sustainable energy future¹. However, it has been shown that hydrogen use presents problems that are likely to prevent its widespread use for vehicle propulsion². First, the energy efficiency of hydrogen production and use is much lower than that of alternatives for propulsion, such as battery power. Second, the cost and effort required for the changes to our infrastructure that would be needed to accommodate high levels of hydrogen use in transportation are large. Third, the pressurized or liquefied storage of hydrogen raises concerns about the weight and volume penalty and the safety of its use in vehicles.

A more likely use of hydrogen is in electric power plants. Because of daily and seasonal variations in power demand, there is often excess production capacity. Rather than sitting idle, these plants could produce hydrogen during periods of low demand for subsequent electricity production when demand increases. This approach would increase plant utilization, but this approach faces concerns about the cost of added equipment and the low ratio of energy produced from stored hydrogen to the energy required to make the hydrogen.

12.2 Hydrogen Properties

Hydrogen is the simplest atom, and hydrogen gas is the lightest gas. Common hydrogen atoms contain a single proton in the nucleus and a single electron orbiting around the nucleus. Two hydrogen atoms combine and share electrons to yield a hydrogen molecule, H₂.

In the following discussion, the properties of hydrogen are presented and are compared with the properties of methane, the main constituent of natural gas and the current dominant gaseous fuel.

12.2.1 Physical State

Hydrogen's boiling point is -423°F (-253°C). Consequently, hydrogen is a gas at standard temperature and pressure, with a density of around 0.00523 lb/ft³. (For comparison, the density of methane gas at standard temperature and pressure is 0.0417 lb/ft³, almost eight times greater than that of hydrogen). The low density of hydrogen complicates the storage of enough material to provide significant energy upon oxidation. The storage issue is especially important in the possible use of hydrogen as a transportation fuel. Pressurization, liquefaction, storage by absorption in the molecular structures of other materials or by storage in compounds that release hydrogen upon decomposition are potential options for reducing the volume of stored hydrogen. All of these approaches involve the use of heavy vessels or chemical storage media that compromise their attractiveness for vehicular applications.

12.2.2 Reaction with Oxygen

When hydrogen reacts with oxygen, as in combustion or in a fuel cell, the reaction products are water and energy. That is:



Methane, the lightest naturally occurring hydrocarbon gas, also releases energy when it reacts with oxygen. The reaction proceeds as follows:

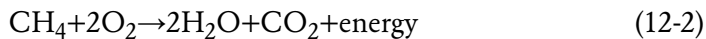

Note that the reactions for both materials produce water, but the methane reaction also produces carbon dioxide. Like hydrogen, methane can be used in a fuel cell to produce electricity.

12.2.3 Gravimetric Heating Values (Energy per unit of weight)

The high and low gravimetric heating values of hydrogen are 61,000 BTU per pound (HHV) and 51,500 BTU per pound (LHV)³. These are very high. For comparison, the values for methane are 24,000 BTU per pound for the HHV and 21,500 BTU per pound for the LHV.

12.2.4 Energy Density (Energy per unit of volume)

Since storage volume is a major concern, a more important energy measure than the gravimetric heating value is the energy available per unit volume (energy density) of hydrogen. At standard temperature and pressure, the high heating value (HHV) energy density for hydrogen is 325 BTU/cubic foot and the low heating value (LHV) energy density is 275 BTU per cubic foot. This compares with methane's HHV energy density of 1,030 BTU per cubic foot and LHV energy density of 930 BTU per cubic foot. Clearly, hydrogen can provide more energy per pound of gas oxidized than methane, but less energy per cubic foot.

Storing hydrogen at high pressure increases its energy density. For example, at 3,000 psig (about 204 times atmospheric pressure) and 68°F, the LHV energy density of hydrogen increases to 48,900 BTU per cubic foot (a 180-fold increase). However, at 3,000 psig and 68°F, methane still has a much higher energy density (184,100 BTU per cubic foot).

Liquefaction also increases the energy density of hydrogen and methane. Cooling hydrogen to its boiling point (-423°F) at atmospheric pressure creates liquid hydrogen with an LHV energy density of 227,850 BTU per cubic

foot. Cooling methane to its boiling point (-259°F) at atmospheric pressure creates a liquid with an LHV energy density of 561,500 BTU per cubic foot.

Table 12-1 summarizes the important properties of hydrogen and methane.

Table 12-1. Properties of Hydrogen and Methane

Property	Hydrogen	Methane
Density (pounds/cubic foot) at standard temperature and pressure	0.00523	0.0417
Boiling Point (°F) at atmospheric pressure	-423	-259
Gravimetric High Heating Value (BTU/pound)	61,000	24,000
Gravimetric Low Heating Value (BTU/pound)	51,500	21,500
Volumetric High Heating Value at standard temperature and pressure (BTU/cubic foot)	325	1,030
Volumetric Low Heating Value at standard temperature and pressure (BTU/cubic foot)	275	930
Volumetric Low Heating Value at 3,000 psi and 68°F (BTU/cubic foot)	48,900	184,100
Volumetric Low Heating Value at Atmospheric Pressure and Boiling Temperature (BTU/cubic foot)	227,850 (-423°F)	561,400 (-259°F)

It should be noted that pressurization and liquefaction both require energy expenditure, thereby reducing the net energy available in pressurized or liquefied fuels.

12.2.5 Diffusion

Because the hydrogen molecule is so small, it can pass through materials that are impenetrable to other gases. Hydrogen leakage by diffusion through containment structures is an issue in storage and transport.

12.2.6 Reactions with Metals

When exposed to hydrogen, certain metals, especially high-strength steel, become brittle. Possible embrittlement is a consideration in selecting materials for storing and transporting hydrogen.

12.3 Hydrogen Production

Any hydrogen-bearing compound is a potential source for producing hydrogen. Currently, most of the hydrogen produced is made from natural gas (mostly methane) for use in the chemical and oil refining industries. Hydrogen production by electrolysis of water is also a mature technology. These technologies, along with several technologies under development and with potential future importance, are discussed in this section.

12.3.1 Hydrogen from Fossil Fuels

Methane Steam Reforming

Steam reforming of methane, discussed in Section 4.8, is a two-step process. First, methane reacts endothermically (absorbs heat) with steam to produce syngas:



In the second step, the carbon monoxide reacts exothermically with water in the “water shift reaction”:

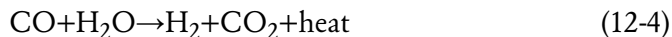

The overall reaction is as follows:

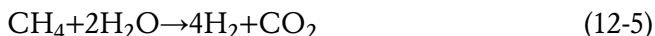

That is, one molecule of methane and two molecules of water yield four molecules of hydrogen and one molecule of carbon dioxide. Note that half of the hydrogen comes from the methane and half comes from the water.

Steam reforming followed by the water shift reaction is also possible with other hydrocarbons besides methane, but methane is now most widely used.

Methane Partial Oxidation

Syngas can also be produced exothermically by reacting methane with limited oxygen:



These products are subsequently converted into hydrogen and carbon dioxide by the water shift reaction. The overall reaction is:

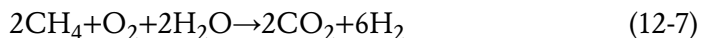

Note that two-thirds of the hydrogen comes from the methane and one-third comes from the water.

Converting natural gas into hydrogen fails to provide a new fuel with greater usefulness for energy production than the material from which it was produced. If hydrogen is to become a widely used fuel, other production methods will be required. Also note that producing hydrogen from methane releases carbon dioxide into the atmosphere.

Coal

Hydrogen can also be obtained by reacting water with coal. Coal is a complex mixture of hydrocarbons and carbon. The steam reforming of the hydrocarbon component proceeds as follows:

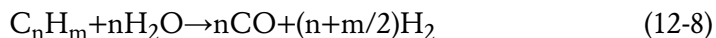

The reaction with the carbon component proceeds as follows:

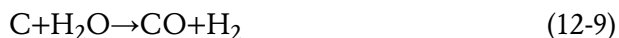

Reaction products from both reactions can then be used to produce carbon dioxide and additional hydrogen by the water shift reaction. The overall reaction for the carbon component of coal is:



Hydrogen production from coal converts a less useful (solid) fuel into a more useful (gaseous) fuel. Note, however, that using coal to produce hydrogen releases carbon dioxide, the major contributor to climate change.

Heavy Oils

Heavy oils, including oil sands and oil shale, contain hydrocarbons of limited usefulness in the as-found state. An option for increasing their usefulness is conversion to gaseous fuel. Steam reforming to produce hydrogen is a possibility.

In addition, thermal decomposition of the hydrocarbons at very high temperature produces carbon and hydrogen as follows:

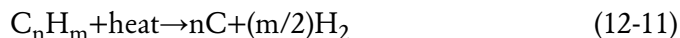

12.3.2 Hydrogen from Biomass

Biomass can be used to produce hydrogen. Processes for this include gasification, photosynthesis and fermentation.

As was discussed in Chapter 7, syngas can be produced via the gasification of biomass as well as from fossil fuels. Biomass decomposes at high temperature, yielding syngas and carbon dioxide. This mixture can be further processed by the water shift reaction to yield additional hydrogen by reacting the carbon monoxide with water (see Section 4.7).

In photosynthesis, the energy in sunlight causes water to split, producing hydrogen and oxygen. In most plants, the hydrogen then becomes part of the carbohydrates, proteins, and oils that make up the biomass. However, some algae and bacteria, and even some genetically modified terrestrial

plants, produce and release molecular hydrogen under certain conditions. Basically, the hydrogen is released rather than entering the reactions that produce biomass. This process, called *biophotolysis*, is a way to split water molecules with energy from sunlight using plant matter as an enabler.

The A.B.E. process (discussed in Appendix N) for producing acetone, butanol, and ethanol (hence A.B.E.) is a two stage fermentation process in which butyric acid and hydrogen are produced in the first stage. Fermentation processes for hydrogen production from biomass and from various types of wastewater have also been formulated. Waste fermentation has the added benefit that it neutralizes contained pathogens while producing useful hydrogen. Each process has specific requirements for enzymes used and processing conditions.

None of the biological hydrogen production methods are now commercially viable, yet the possibility that a simple and economical way might be developed to produce hydrogen has stimulated a large research effort to understand and optimize the biological processes. Thousands of scientists are exploring plant genetics, plant and enzyme modification by genetic engineering, and conditions (such as light vs. dark fermentation and aerobic vs. anaerobic fermentation) that maximize hydrogen yields.

12.3.3 Hydrogen from Water

As is often demonstrated in high school chemistry courses, passing direct electrical current through water produces hydrogen and oxygen. This process is called hydrolysis. An electrolyte, commonly potassium hydroxide, is dissolved in the water to make it conductive. Figure 12-1 shows the basic principle. Hydrogen gas bubbles from the negative electrode and oxygen bubbles from the positive electrode.

It is noteworthy that in electrolysis, one energy carrier (electricity) is used to make another energy carrier (hydrogen). Producing large volumes of hydrogen by electrolysis is logical if electricity is abundant and cheap and if the hydrogen can serve a useful purpose that is not practically achievable with electricity.

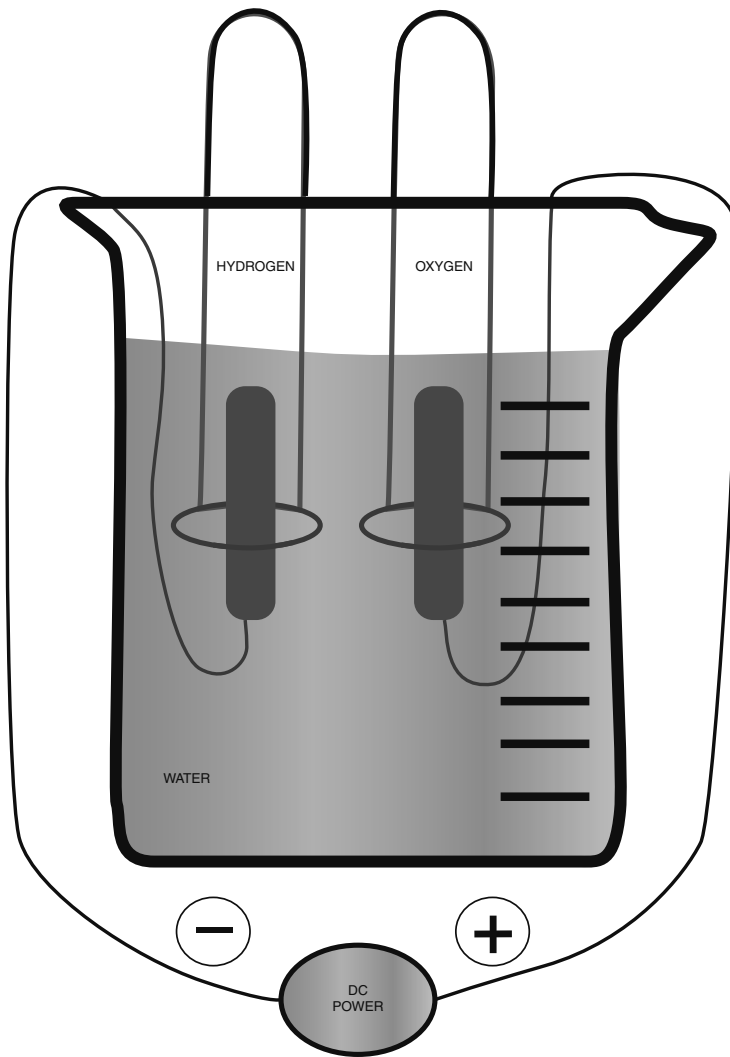

Figure 12-1. Water Electrolysis

The environmental impact of water electrolysis depends on the method used to make the electricity consumed in the process. Fossil-fueled power plants produce carbon dioxide, while solar, wind, geothermal, hydroenergy, and nuclear sources produce electricity without releasing carbon dioxide. Of course, grid electricity used for electrolysis normally comes from all of the sources that feed electricity to the grid.

The electrical energy required to electrolyze water decreases with increasing temperature. Part of the energy needed to split the water molecules can be provided by heat. Possibilities for obtaining inexpensive heat to reduce electricity requirements for electrolysis include the use of waste heat from industrial processes, solar heat or heat from a high temperature nuclear reactor.

Hydrolysis of water using sunlight can be performed in a unit that combines the photovoltaic production of electricity and the use of that electricity to split water.

Biophotolysis was discussed in the previous section.

Water spontaneously decomposes into hydrogen and oxygen at high temperature (4,500°F).

Thermochemical processes can also produce hydrogen. These processes involve the repeated decomposition and regeneration of chemicals used in the process. For example, a process based on reactions between iodine and sulfuric acid proceeds according to the following series of reactions:

1. Decomposition of sulfuric acid to produce sulfur dioxide, water and oxygen:

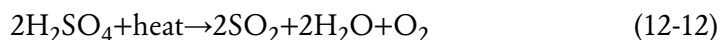

2. Reaction of sulfur dioxide with iodine and water to regenerate the sulfuric acid and produce hydrogen iodide, HI:

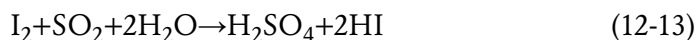

3. Decomposition of hydrogen iodide to regenerate iodine and produce hydrogen:



Basically, water and heat are the input quantities and hydrogen and oxygen are the output quantities. The other chemicals are repeatedly used and regenerated within the process.

12.4 Hydrogen Storage

If it is to become a significant energy carrier, facilities will be needed to store hydrogen for stationary and mobile applications. Hydrogen storage poses some significant engineering challenges, especially storage in vehicles. An often-stated design objective for hydrogen-fueled vehicles is a range of 300 miles while achieving adequate safety and acceptable weight and volume. The quantity of hydrogen needed for a range of 300 miles is 7 to 14 pounds, depending on vehicle characteristics. This does not sound like much weight, but the vessels required to hold this amount of hydrogen are heavy.

12.4.1 Pressurized Storage

The pressurization of hydrogen to increase its energy density requires an energy expenditure that increases as the storage pressure increases. The estimated energy required for pressurization ranges from around 7 percent of the energy contained in the hydrogen (at a pressure of 200 atmospheres) to 12 percent (at 800 atmospheres)⁴.

Pressurized storage requires strong vessels that can withstand the high pressure, and these vessels must prevent significant hydrogen leakage and must tolerate contact with hydrogen without suffering significant embrittlement. The weight and volume of pressurized storage vessels are limiting factors for fuel storage in vehicles.

12.4.2 Liquefied Storage

The liquefaction of hydrogen at cryogenic temperatures also requires energy expenditures to cool the gas to below its boiling temperature. The amount

of energy needed to cool hydrogen for cryogenic storage is even higher than the amount required for pressurization.

Liquefied storage also requires highly insulated vessels to minimize heat transfer from the surroundings.

12.4.3 Storage in Solids

Hydrogen can be stored in solids by absorption in a solid matrix or by reacting it with suitable materials to form hydrogen-bearing compounds that will decompose to yield hydrogen when it is needed. For use as a hydrogen storage medium, desirable properties are:

- Ease of capturing hydrogen in the solid
- Large mass of stored hydrogen per unit of solid mass
- Ease of hydrogen release when needed
- Ease of restoring the material used to capture hydrogen

Metal hydrides and alanates (compounds such as sodium alanate, NaAlH_4), show some promise for storing hydrogen, but as yet, no practical method for hydrogen storage in solids is available.

12.5 Options for Hydrogen Production Sites

Hydrogen can be produced in a large centralized production facility or in smaller local electrolysis units that use electrical energy transferred over the electrical transmission and distribution system. Thus, the choices are to deliver hydrogen or to deliver electricity. Larger centralized plants would have lower costs per pound of hydrogen produced, but localized production avoids the need for large-scale hydrogen transport and storage.

12.6 Hydrogen Distribution

Hydrogen distribution usually refers to the transfer of hydrogen from a bulk storage facility into a vehicle's storage system. It is analogous to filling a gasoline tank at a filling station. A high degree of safety and adequate speed of refueling are design requirements for hydrogen filling stations.

12.7 Use of Hydrogen as a Fuel

Hydrogen may be used to provide mechanical energy by combustion and for producing electrical energy with a fuel cell or with a turbine-generator. Using hydrogen in a combustion system is similar to applications using other gaseous fuels such as methane. Fuel cells are basically batteries with continuous replenishment of reactants.

12.7.1 Stationary Applications

Electric utilities must build enough capacity to satisfy peak demands. During periods of lower demand, some capacity will be idle and available for producing electricity for electrolyzing water. There are no fuel costs for an idle plant, but capital costs (and some operation costs) continue. Producing hydrogen during low-load periods (generally at night and in the spring and fall) is envisioned as a way to achieve a higher financial return on the investment in a power plant. The hydrogen produced could be sold, or stored and later used by the utility to produce electricity during high-load periods. This approach is an example of "load leveling."

12.7.2 Mobile Applications

The use of hydrogen to propel vehicles imposes additional considerations and requirements. The weight and volume of on-board hydrogen storage vessels are important in mobile applications.

12.8 Energy Efficiency

Hydrogen may be used to store and carry energy in the future. Consequently, it is important to examine the energy efficiency of these activities. Energy is needed to produce, store, transport, distribute, and use hydrogen. These energy expenditures reduce the net energy available when the hydrogen is used as a fuel.

The main competitor to hydrogen fuel cells for electric vehicle energy is the battery. Fuel cells and rechargeable batteries both use electrical energy to create chemical energy that is subsequently transformed back into electrical energy. Consequently, the relative energy efficiency of fuel cells and batteries is an important issue. Section 18.5 provides a breakdown of the energy efficiencies of the steps in the use of fuel cells and batteries. Accounting for all of the energy-consuming steps in getting from grid electricity to electricity produced with a battery or a fuel cell shows that batteries are currently about 2.5 times as efficient.

12.8.1 Energy Efficiency in Production

The main current and potential future hydrogen production methods have been described in previous sections. For the consideration of energy efficiency in hydrogen production, the focus here will be on production by electrolysis. Production from natural gas is currently the dominant way to make hydrogen, but future resource availability, cost, and environmental acceptability will prohibit its widespread use. One or more of the other methods described above may prove superior, but they are currently too underdeveloped to warrant reliance on them. Electrolysis is a proven technology that is ready for immediate deployment.

As with all energy conversions, the production of hydrogen by electrolysis results in unavoidable energy losses. The energy efficiency of electrolysis (energy in hydrogen produced/energy in electricity consumed) is around 70 percent with current technology. High temperature electrolysis could replace some of the electrical energy with heat energy.

12.8.2 Hydrogen Energy Conversion

Consider electrical energy production using hydrogen. The process involves using electrical energy to make hydrogen, then later using that hydrogen to make electricity. Since energy losses occur with both conversions, the only rationale for pursuing this route is that energy can be stored in hydrogen.

The conversion from chemical to electrical energy can be accomplished in a fuel cell or a heat engine (typically a dual-cycle turbine-generator). The maximum energy efficiency for either approach is 50 to 60 percent. Therefore, the combined energy efficiency of the production step and the conversion step is 35 to 40 percent. Additional energy is required for ancillary processes such as pressurization and liquefaction. Overall, the energy efficiency of producing electricity with hydrogen is less than 25 percent⁵. That is, at least four kilowatt-hours of grid electricity are consumed in producing one kilowatt-hour of electricity with hydrogen.

12.9 Hydrogen's Future

Clearly, proponents of a hydrogen economy have overstated the potential for hydrogen to be a major energy supplier in the future. In 2002, for example, in the National Hydrogen Energy Roadmap¹, Spencer Abraham, the U.S. Secretary of Energy, stated, "A hydrogen economy will mean a world where our pollution problems are solved and where our need of abundant and affordable energy is secure ... and concerns about dwindling resources are a thing of the past." This type of excessive enthusiasm has infected politicians, bureaucrats, and journalists. Policy has been misdirected and the public has been misled.

A more likely outcome than that envisioned in the "hydrogen economy" is one in which hydrogen will play a role in our energy future, but a much smaller role that is touted by its proponents. Continued work on hydrogen technology is needed, but funding for this work should not result in weak funding for more promising alternatives.

Note: On 8 May 2009, the *New York Times*⁶ reported that the U.S. Department of Energy was ending all funding for research on fuel cells for vehicle applications.

References

1. U.S. Department of Energy “National Hydrogen Energy Roadmap” Based on the results of the National Hydrogen Energy Roadmap Workshop, Washington, D.C., November, 2002 at http://www.hydrogen.energy.gov/pdfs/national_h2_roadmap.pdf.
2. Romm, J. J. *The Hype about Hydrogen* Washington, DC: Island Press, 2004.
3. “Module 1: Hydrogen Properties” College of the Desert at http://www1.eere.energy.gov/hydrogenandfuelcells/tech_validation/pdfs/fcm01r0.pdf.
4. Bossel, U., Eliason, B., and Taylor, G. “The Future of the Hydrogen Economy: Bright or Bleak” at <http://www.efcf.com/reports/E08.pdf>.
5. Bossel, U. “Efficiency of Hydrogen Fuel Cell, Diesel-SOFC-Hybrid and Battery Electric Vehicles” European Fuel Cell Forum, 20 October 2003 at <http://www.efcf.com/reports/E04.pdf>.
6. Wald, M. L., “U.S. Drops Research into Fuel Cells for Cars,” *New York Times*, 8 May 2009).

13

Energy Transport

The Main Points

- Energy and materials used for providing energy are rarely produced where they are used.
- Most coal moves from mines to power plants in trains.
- Pipelines provide the most efficient and economical way to move liquid and gaseous fuels.
- The U.S. has extensive pipelines for liquids (crude oil and petroleum products) and gases (natural gas and propane).
- Existing pipelines are unsuitable for ethanol and hydrogen.
- High-voltage electrical transmission is used to reduce energy losses.
- Foreign-sourced liquid and gaseous fuels are transported in large ships.
- Large increases in the extent and capacity of the electrical transmission and distribution system will be needed in the future.
- Energy transport systems impact the environment, eliciting major opposition to their construction.
- Future electrical transmission and distribution systems will be more efficient than current systems because of the implementation of “Smart Grid” principles.
- The U.S. must make a large investment in energy transport for the future.

13.1 Introduction

Usable energy and the materials used as sources of usable energy are rarely produced at the location where they are used. The transport of energy and of the raw materials needed to produce energy incurs large expenditures of money and energy and causes environmental impacts that elicit opposition. These are major considerations in ensuring a transport system that adequately serves energy needs in the future.

13.2 Coal Transport

More than 90 percent of the coal used in the U.S. is used by electric power plants and steel mills. Coal mining occurs principally in the west, in the Midwest, and in Appalachia.

There is a trade-off in using coal to produce electricity, as to whether it is better to produce electricity near the mines (in mine-mouth power plants) and transport that electricity to users, or to haul coal to power plants located near users. Consumers prefer that coal-fueled power plants, and their associated pollution, be located far away. But electrical transmission losses, cost, and public acceptance of transmission lines, grid reliability, and stability concerns, access to sufficient cooling water, and utility business models are all factors in deciding on plant siting.

In 2002, coal traveled from mines to users by train (65 percent), trucks (13 percent), conveyer belt and slurry pipeline (10 percent), and barge (12 percent).¹

13.3 Liquid Fuel Transport

13.3.1 Oil-Based Fuels

The transport of oil-based liquid fuels begins with the movement of oil from wells to refineries. The distances involved may be short, as in some

sites in Texas and California where wells and refineries are close to one another, but wells and refineries are usually far from one another. Also, America increasingly depends on oil and oil products imported from distant sources. This oil travels from the wells to tanker ships or to refineries that process the oil before loading it onto ships. The ships offload the crude oil or refined products at U.S. seaports.

Pipelines provide the most economical way to transport liquid fuels. The U.S. has around 150,000 miles of pipeline for carrying crude oil and refined products².

Oil-based liquid fuels include gasoline, diesel fuel, jet fuel, and fuel oil. In the U.S., these liquids move from domestic refineries or seaports to regional distribution terminals via pipelines that crisscross the country. The terminals store the liquid fuels. Tanker trucks then carry the fuels to retailers (such as filling stations) or to end users.

Liquid fuels made from oil sands or oil shale may become important in the future. If this occurs, new pipelines will be needed to transport fuel from processing facilities located near the resource deposits, which exist in regions that are not currently served by pipelines. This includes pipelines for bringing oil sand products from Canada to the U.S.

This complex transport system, composed of ships, pipelines, and trucks, must operate smoothly and consistently if liquid fuels are to be available when and where needed. A breakdown in any part of the transport chain can cause major disruptions.

13.3.2 Liquid Biofuels

If liquid biofuels grow into a major energy source, their transport will require new infrastructure. The first reason for this is the anticipated location of biofuel production facilities. Biofuel production facilities will have much smaller throughputs than oil refineries and will be dispersed throughout growing regions in order to minimize hauling distances for the biomass. Gathering liquid biofuels from biorefineries will require a transport system

that serves many widely spaced refineries, each with a much smaller production rate than an oil refinery. As with oil-based liquid fuels, the most efficient way to transport liquid biofuels to distribution terminals is via pipelines. However, existing pipelines do not adequately serve major anticipated biofuel production regions. In addition, current pipelines are unsuitable for ethanol transport. Pipelines for ethanol, the biofuel that currently dominates development efforts, must be free of water because ethanol, unlike hydrocarbons, will absorb water or other contaminants in pipelines, with resulting degradation of the ethanol's suitability as a fuel.

After the liquid biofuel reaches distribution terminals, it would be stored and then carried by truck to retailers and users in the same fashion as hydrocarbon fuels are carried.

13.4 Gaseous Fuel Transport

13.4.1 Natural Gas

Pipelines are used to carry natural gas from wells to users. The gas pipeline system in the U.S. includes around 1.5 million miles of pipes of various sizes¹. The main components of the system are³:

- Gathering lines: Small diameter pipes carry gas from the wells to a gas processing plant.
- Processing plants: These facilities separate out the condensable gases (propane and butane) and impurities.
- Mainline transmission systems: Large diameter pipelines carry gas to market areas.
- Market hubs/centers: Locations where pipelines intersect and gas flows are routed.

- **Underground storage facilities:** Underground reservoirs are used to store natural gas. Since changes in gas consumption cannot be matched quickly by changes in gas flow from distant wells, gas flows from nearby reservoirs are used to provide needed gas. Reservoirs are filled during low-demand periods and drained during high-demand periods. About 400 underground storage facilities exist in the U.S. Depleted oil and gas wells and salt caverns can serve as reservoirs.
- **Liquefied gas systems:** Stored liquefied gas (natural gas and propane) provides reserves that can be re-gasified and injected into the pipeline when needed to help satisfy demand. There are around 100 liquefied gas storage systems in the U.S.
- **Local distribution lines** to homes, businesses, and industries.

Natural gas demand experiences daily and seasonal variations. Demand is highest in the cold winter months. Gas suppliers implement measures to ensure that supply capability matches demand. Utilities may stop service to users who agree to interruptible service in return for lower gas prices. Matching supply to demand may also be accomplished by drawing gas from stored reserves.

Pipelines are economical only when supplied by a region with large gas reserves. Natural gas also occurs in smaller quantities in many locations in the U.S. Because it is uneconomical to provide transport facilities for small gas resources, the gas is usually called “stranded gas.” On-site liquefaction is sometimes employed to facilitate transport. Using these small gas resources for local heating or small-scale electricity production is possible, but uncommon.

As with liquid hydrocarbons, natural gas is also imported. Huge ships carry natural gas in the liquefied state. Liquefaction requires cooling the gas to temperatures below its liquefaction temperature (-259°F) and keeping it cold until returning it to the gaseous state and feeding it into pipelines.

13.4.2 Propane

Propane is also an important gaseous fuel. Propane is obtained by separation from natural gas and as a by-product of oil refining. These sources contribute to domestic production in about equal quantities. Imports provide about 10 percent of U.S. propane. Propane, unlike natural gas, liquefies at normal temperature and modestly elevated pressure. Consequently, liquid propane provides a concentrated energy source that occupies a small volume and is easily transported. Propane serves home energy needs in areas not served by natural gas lines. It also serves specialized functions such as home barbeque fuel where small, portable tanks store the propane.

Pipelines carry gaseous propane throughout the U.S. in a network covering over 70,000 miles⁴. The propane arrives at distribution centers, where it is pressurized into the liquid state and stored. Special trucks with pressurized tanks carry propane to users, where it is transferred into pressurized tanks.

13.4.3 Hydrogen

Hydrogen is under consideration as a fuel for major deployment in the future. Hydrogen will likely be produced by the electrolysis of water. Water electrolysis can occur in large, centralized production facilities or in small, decentralized facilities close to the point of use. The transport issue is whether to transport hydrogen or to transport electricity for local hydrogen production.

Hydrogen transport and storage are more difficult than natural gas transport and storage. The difficulty is due mainly to two properties of hydrogen (see Chapter 12):

- Because of the small size of hydrogen molecules, it diffuses through metals that are impervious to other gases.
- Hydrogen causes embrittlement in high strength steel and alloys containing nickel and titanium

Because of these effects, the existing infrastructure for natural gas transport and storage cannot be used for hydrogen. Technology for hydrogen transport and storage is available, but the infrastructure that would be needed for a large hydrogen energy economy based on centralized production would have to be built anew and at considerable expense. Decentralized hydrogen production would shift the problem from transporting and storing hydrogen to that of transporting electricity to the production site.

13.5 Electricity Transport

13.5.1 The Electrical Power System

The electrical power system consists of producers, power lines, and auxiliary equipment such as transformers to increase or decrease voltage, switches and circuit breakers to allow or prevent the passage of current, and devices to control the timing of voltages and currents (characterized by the power factor discussed below). The system is huge, with thousands of producers and hundreds of thousands of miles of power lines.

The U.S. electrical power system is about to experience major changes that include the following:

- The system will be required to deliver much more energy as electricity becomes the preferred form of energy in America.
- The mix of producers will change as America reduces fossil fuel use and increases the use of wind, solar, geothermal, hydroenergy, and, possibly, nuclear sources.
- The intermittency of solar and wind sources will require that the system has the ability to compensate for frequent and sudden changes in production from these sources.

- The size and characteristics of the electricity transport system will change. More power lines and new, efficiency-increasing technology will be needed to provide greater carrying capacity.
- Changes in equipment and use patterns at the consumer end to permit greater efficiencies, improved reliability, and lower costs for electrical energy will occur.

Electricity transport is unique in that its production must match demand continuously and instantaneously. This balance is achieved in an electrical system that includes base-load producers, load-following producers, and producers of opportunity (see below).

Base-load plants are generally those whose economics or limited ability to change power output rapidly favor operating at constant power. Having low operating costs relative to capital cost usually favors base-load operation. For example, since nuclear plants have low operating costs relative to capital costs, utilities usually prefer to operate them as base-load producers.

Load-following plants are those that increase or decrease their generation as needed to maintain a balance between production and consumption. Load-following plants must be able to change generation quickly. Low capital costs are important in load-following plants because they operate at zero or reduced power much of the time, producing no return or reduced return on investment. Gas turbine power plants are important providers of load-following capability.

Producers of opportunity operate whenever the facility is capable of producing power. Some power plants can provide clean energy with low operating costs, but their power output is controlled by nature. Examples are solar power and wind power. Generally, it is desirable to use all of the energy that these systems can deliver and to use other producers in the system to compensate for power production changes imposed by nature.

The electrical network consists of many interconnected producers and consumers. Changes in production or consumption anywhere in the network

are felt throughout the network unless they are restricted by controllers on segments of the transmission system. Consequently, the sudden shutdown or startup of a large power plant or large consumer facility triggers immediate control action to re-establish a balance. (Legend has it that a fisherman drowned in Tennessee because water flow through a dam increased suddenly to compensate for the shutdown of a power plant in Illinois.)

The electrical system must be capable of satisfying demand at all times, including periods of peak demand. Consequently some plants are often idle or are producing below capacity. Older, dirtier, less efficient plants are often used when needed to contribute to peak production. Having adequate capacity to satisfy peak loads forces utilities to have plants that will see only part-time service. Reducing peak loads, and thereby reducing the need for part-time plants, reduces the required investment for utilities.

Steps taken to reduce energy demand peaking are called load leveling. Demand-side (user) steps can help with load leveling. Inducements (usually economic) to operate electrical equipment when overall demand is low can reduce peak demand. For example, one utility offered free water heaters to customers who would accept utility-initiated periods of inoperation.

On the supply side, one load-leveling approach is energy storage. During periods of low demand, utilities can use excess generation capacity to power facilities such as pumped storage systems, batteries, or hydrogen production and storage systems to capture energy for release during subsequent high demand periods.

Energy storage is also often mentioned as a way to deal with the intermittency of wind and solar power. As long as intermittent sources supply a small fraction of total electrical demand, it is desirable to feed all of their production into the grid. If power from intermittent sources either exceeds power demand or causes excessive demands for changing energy flows in the grid, storage becomes desirable. Of course, the added facilities for energy storage add to the cost of electricity from the intermittent sources, and some energy losses inevitably occur in the transformations from electricity to stored energy and back from stored energy to electricity.

13.5.2 Electricity Transmission and Distribution

Electricity flows from the power plant into the transmission network, and from the transmission network into the distribution network. Transmission refers to the transfer of bulk quantities of electricity from power plants to distributors. Distribution refers to the transfer of electricity from distributors to users.

Electricity transmission may be done via direct current (DC) or alternating current (AC). Almost all transmission is AC. A major advantage of AC over DC is that simple devices called transformers can be used to increase or decrease AC voltage, but not DC voltage.

Transmission networks use high voltages to reduce losses of energy in the transmission lines. Power delivery is equal to the product of voltage and current. AC transformers change voltages and currents without changing power delivery (except for some losses due to heating in the transformer). A transformer causes a change in current that is inversely proportional to a change in voltage. For example, doubling the voltage halves the current, and the power remains unchanged.

The advantage of using high voltages and low currents in transmission of electricity is that this approach reduces energy losses due to resistance heating of the conductors. Electrical heating, called Joule heating, increases with the square of the current:

$$P_J = I^2R \quad (13-1)$$

where

- P_J = Joule heating power
- I = electrical current
- R = electrical resistance

For example, halving the current flowing through a transmission line will reduce Joule heating by a factor of four. High-voltage transmission line voltages are typically 110,000 volts and higher. Since such high voltages are not

suitable for end users, distributors use step-down transformers to reduce voltage. Losses due to transmission line heating amount to a bit over 7 percent of U.S. electrical energy consumption.

The frequency of the alternating current produced by a turbine-generator is determined by the rotational speed of the turbine shaft. The rotational speed depends on the difference between the rate at which energy is delivered to the turbine blades by the working fluid and the rate at which the shaft's rotational energy is converted to electricity in the generator. If the turbine power exceeds the generator power demand, the shaft rotational speed increases, and the frequency of the electricity increases. The reverse occurs if generator power demand exceeds turbine power.

For many reasons, the frequency of the electricity produced must be maintained within close limits. Since turbine shaft speed and the frequency of the electricity produced change immediately following imbalances between power production and power demand, maintaining constant shaft speed and frequency is the goal of power plant control systems. The modern network maintains the electrical frequency very close to 60 Hertz (cycles per second) in the U.S. electric power system.

Some components in an AC electrical network cause a phase shift between voltage and current. That is, the waveforms for the oscillating voltages and currents are displaced relative to one another. Maximum useful power is delivered only when voltage and current are in phase with one another (no displacement between the wave forms of current and voltage). When they are not in phase, the circuit is carrying current that does not contribute to usable power. As a result, there are greater heating losses in the transmission lines for the same rate of delivery of usable power than would occur if the voltage and current were in phase. A term called the *power factor* is defined as the usable power divided by the power that would be delivered if voltage and current were in phase with one another. Components are installed in electrical networks to cause the power factor to be as high as practical, with a power factor of 1 being the goal.

13.5.3 The Smart Grid

Planners are now preparing for a much larger and more efficient electrical system for the future. The new system is called the Smart Grid⁵. While in the past, the term “grid” usually referred to the power lines and auxiliary equipment used to transport electricity, the “Smart Grid” encompasses the transmission and distribution systems and the users.

The Smart Grid is not a simple concept that can be explained in a few words, but the basic idea is to use computers and information technology to monitor and control electrical systems and, thereby, improve efficiency, reliability, and cost. The U.S. Department of Energy provides the following definition of the properties of the Smart Grid⁵:

- Self-healing from power disturbance events
- Enabling active participation by consumers in demand response
- Operating resiliently against physical and cyber attack
- Providing power quality for twenty-first century needs
- Accommodating all generation and storage options
- Enabling new products, services, and markets
- Optimizing assets and operating efficiently

Some of these features are to be implemented by utilities. Information technology will provide indications of existing and incipient component malfunctions or sub-optimal operation. The grid’s characteristics will be designed for robustness, and grid management will employ optimal control, continuous monitoring, and problem mitigation strategies to achieve reliable and efficient delivery of electrical energy.

Interestingly, some benefits of the smart grid will involve actions by the consumer as well. Many of these actions will focus on consumer activities that contribute to load leveling and distributed electricity production. Smart meters that enable time-of-use pricing will encourage consumption during times of non-peak demand, when electricity costs charged by some utilities are lower. For example, water heating and battery charging for electric and plug-in hybrid vehicles at night rather than during the day, when power demand is higher, will help to reduce peak demand. Another interesting option is an air conditioning system that makes ice at night when non-peak power is available⁶. The ice later provides daytime cooling.

Consumers can also become producers. As local electricity production (mainly with solar photovoltaic systems but with some contribution from wind turbines) increases, these devices can reverse the traditional flow of electricity and feed any excess power into the grid. Some even envision the use of stored energy in vehicle batteries to feed the grid during peak load periods. This approach is called vehicle-to-grid or v2g. However, the impact on battery life and the need to save the stored energy for use in vehicle propulsion will probably limit v2g power generation to emergency situations.

13.6 Environmental Issues

Energy transport requires construction of facilities that are objectionable to many citizens. Concerns include potential damage to the environment and undesirable aesthetic effects. For example some citizens are concerned about disruption of land during pipeline construction and possible leaks after operation begins, and electric power lines alter the landscape in a way that is distasteful to many citizens. Thus, there is an unavoidable conflict between a desire to leave things as they are and accepting changes in order to have the energy needed to sustain society.

13.7 Overview

America must upgrade its energy transport infrastructure to accommodate increases in energy consumption and changes in the ways that energy is produced and consumed. Expanding and improving America's energy transport system will require great effort and expense, whether the transported quantity is coal, liquid, gas, or electricity. For each of these transport systems, there will be debate about the benefits versus the financial, environmental, and aesthetic costs. The creation of a new energy transport infrastructure is a looming problem whose resolution will be determined by political as well as technical and economic considerations.

References

1. "Coal Transport: Rates and Trends" Energy Information Administration at <http://www.eia.gov/cneaf/coal/page/trans/ratesntrends.html>.
2. "U.S. Oil and Gas Pipeline Mileage" Bureau of Transportation Statistics at http://www.bts.gov/publications/national_transportation_statistics/html/table_01_10.html.
3. "About U.S. Natural Gas Pipelines" U.S. Energy Information Administration report at http://www.eia.gov/pub/oil_gas/natural_gas/analysis_publications/ngpipeline/index.html.
4. "Propane" The Need Project at http://www.need.org/needpdf/infobook_activities/SecInfo/PropaneS.pdf.
5. "Smart Grid Principal Characteristic Enables New Products, Services and Products" National Energy Technology Laboratory report at http://www.netl.doe.gov/smartgrid/referenceshelf/whitepapers/Appendix%20A6%20-%20Enables%20Markets%20v3_0.pdf.
6. Ice Energy Co. web site at <http://www.ice-energy.com>.

Exercises

- 13-1. Hauling coal by train consumes around 362 BTU per ton mile. How much energy is used in the U.S. per year to haul coal if the average haul is 1,000 miles?
- 13-2. The U.S. has around 157,000 miles of high voltage power lines. Building new lines costs around \$1 million per mile. If the U.S. has to double the size of its electrical transmission system in order to handle a doubling of electricity use, estimate how much will have to be spent for high voltage lines. If new power plants cost around \$3,000 per kilowatt, how do the costs of new high voltage lines compare with the cost of new power plants?
- 13-3. What is the dollar value of annual U.S. electrical transmission losses if electricity is worth 11 cents per kilowatt-hour?

Part III: **ENERGY DEMAND**



14

**Population and
Energy Demand**

The Main Points

- **World population will be a major factor in determining future energy needs (maybe THE major factor).**
- **Traditional population growth is exponential in nature.**
- **The population growth rate is currently slowing.**
- **World population is expected to grow from 6.8 billion (2009) to over 9 billion by the mid-twenty-first century.**
- **Most of the future population growth will be in developing countries.**
- **The preponderance of the increased population will expect to have more energy.**

14.1 Introduction

World population has been growing exponentially for many years. Much of this growth has been—and is continuing—in developing countries, where the population expects to increase its standard of living and to have the energy required for this increase. The energy issue for the future is intimately related to population and demographics.

It is clear that population growth cannot continue indefinitely. World resource limitations will eventually limit population. The resource base includes exhaustible resources and renewable resources. A sustainable world population depends on the capacity of renewable resources to replace exhaustible resources as they are depleted, coupled with some acceptable level of per capita consumption.

Through the years, attempts have been made to assess the maximum sustainable population of the world. Many analysts have estimated the maxi-

mum sustainable world population. Their results are generally wrong. Some of their estimates are even lower than the 2009 world population of around 6.8 billion.

Stabilizing population at some level above the current level may not be good enough. Actual population reductions may be necessary to achieve sustainability. Availability of all of the resources needed to sustain increased populations will be an issue, but food availability is the most fundamental resource needed for survival. The so-called “Green Revolution” that started in the mid-twentieth century provided greatly increased agricultural production, but this was achieved with fertilizers and pesticides that were produced from fossil hydrocarbons. Energy for irrigation and farm machinery also comes from fossil hydrocarbons. The question is, “What will happen to agricultural production and the number of people that can be sustained when fossil hydrocarbons become scarce or unavailable?”

14.2 Population History

The world and U.S. population histories are shown in Figures 14.1 and 14.2.¹ 2009 populations were around 6.8 billion for the world and 306 million for the U.S. Both world and U.S. populations currently exhibit exponential growth.

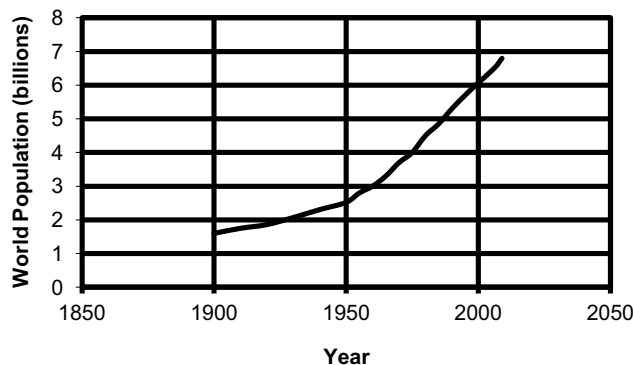

Figure 14-1. World Population History

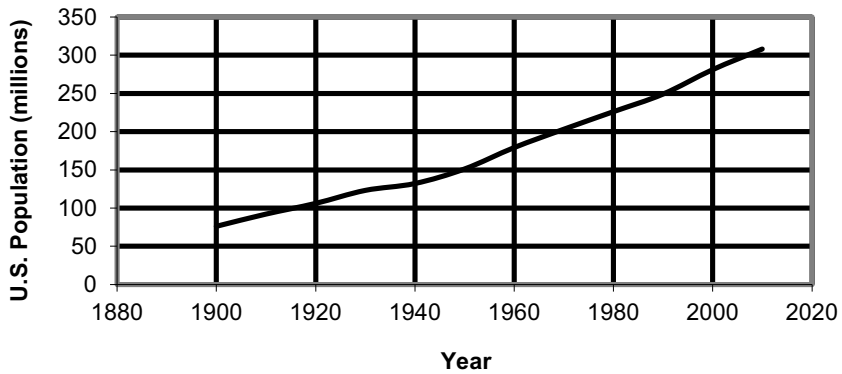

Figure 14-2. U.S. Population History

14.3 Exponential Population Growth

Exponential population growth is represented mathematically by:

$$dP/dt = (b-d)P \quad (14-1)$$

where

- P = population
- t = time
- dP/dt = the rate of change of population
- b = birth rate
- d = death rate

The solution to Equation 14-1 is:

$$P = P_0 \exp((b-d)t) \quad (14-2)$$

where:

- P_0 = population at a selected starting time ($t = 0$)

It can be shown that the time required to double a population that is growing exponentially is given by:

$$T_d = 0.693/(b-d) \quad (14-3)$$

where:

T_d = time required to double the population

The quantity $(b-d)$ is called the rate of natural increase. For the world, the birth rate in the early twenty-first century is about 21 births per thousand people ($b = 0.021$), and the death rate is about nine deaths per thousand people ($d = 0.009$). The doubling time for world population (assuming constant values of b and d) is 60 years. For the U.S., the birth rate is about 14 births per thousand people, and the death rate is about eight, giving a doubling time of 116 years.

14.4 The Demographic Transition and Population Stabilization

Slowing of population growth occurs with a decreasing birth rate and/or an increasing death rate. Statistics show the worldwide death rate has been decreasing. This decrease is due to better sanitation, better health care, and better nutrition. Simultaneously, the birth rate has been decreasing throughout most of the world. Many factors account for this decrease, but societal and economic forces are the basis for most of these factors. The shift from high birth rates and high death rates to an era of low birth rates and low death rates is called the Demographic Transition.

Figure 14-3 shows a plausible, but hypothetical, path to population stabilization. The population curve has the S-shaped (sigmoid) behavior seen in Chapter 4 and Appendix F in estimating future fossil hydrocarbon production and consumption.

One is tempted to turn to logistic function modeling, as was used successfully to forecast U.S. oil production (see Section 4.2.6 and Appendix F).

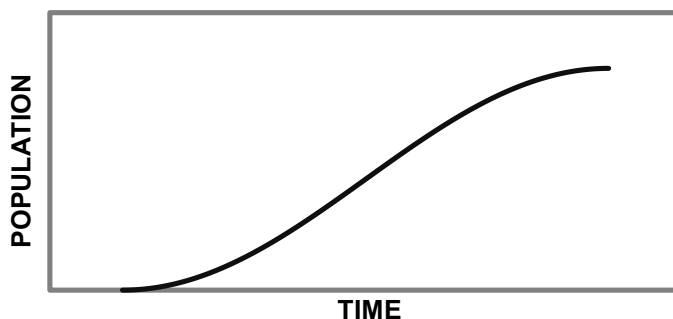

Figure 14-3. A Hypothetical Path to Population Stabilization

However, predicting future population involves complications. For example, how would projections change if we should find that growth rates had been increased by the temporary availability of resources such as oil? A plausible outcome is that the population that is sustainable without the availability of these resources is smaller than what would have been possible with continued availability. In this case, population would peak and then decline to a resource-constrained level. Figure 14-4 shows a hypothetical population curve for such a scenario. Other complications include the possibility of wars, pandemics, and famines that would result in decreased populations and technological advances that would enable larger sustainable populations. The conclusion is population forecasting is even more uncertain than resource forecasting.

14.5 Total Fertility Rates

Another way to assess the factors that influence population growth is with total fertility rates. If there were no deaths among women before the end of child-bearing age, and male and female populations were equal, then replacing the existing population would require a total fertility rate of exactly 2.0 children per woman. The total fertility rate required for replacing the existing population under actual conditions is called the replacement rate and is currently around 2.1 for developed countries and between 2.5 and 3.3 for developing countries, where early mortalities are more frequent. Values of

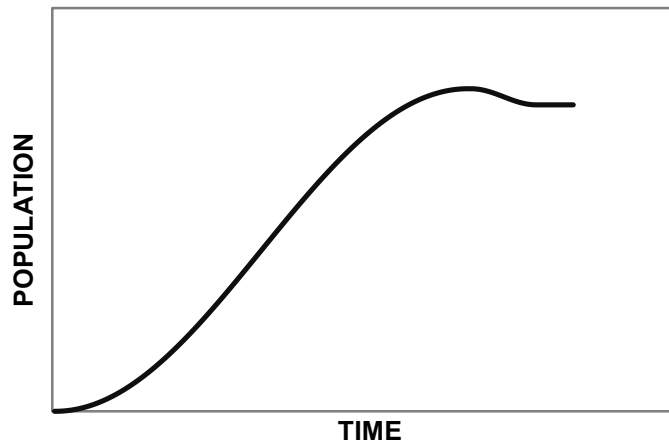

Figure 14-4. A Hypothetical Path Following a Period of Temporary Abundance

total fertility rate below the replacement rate are referred to as sub-replacement rates.

The total fertility rate in the U.S. dropped from around four in 1900 to around two in the early twenty-first century. The world total fertility rate is around 2.7 and is decreasing. These decreases are cause for optimism that the world population will stabilize at a sustainable level. Some developed countries are already experiencing population decreases. Of course, this does not happen without concomitant problems, one of which is funding for pensions for older citizens through taxes on working citizens.

14.6 Future Population Estimates

The U.S. Census Bureau has estimated future population levels². The estimates are that world population will increase from its 2009 level of 6.8 billion to around 8 billion in 2025 and 9.5 billion in 2050. Other estimates generally fall around 9 billion for 2050. Interestingly, while the estimate for the U.S. is to increase to 357 million in 2025 and 439 million in 2050, the estimate for western Europe is to increase from around 400 million to 406 million in 2025, then decrease to 387 million in 2050.

14.7 Energy Implications

Energy requirements are the product of the number of people and the energy required per person. Demographers provide population estimates as presented above. The energy required per future world citizen can only be provided by educated guesswork.

One approach is to assume everyone will demand as much energy as is currently consumed by U.S. citizens. 306 million U.S. citizens currently use about 100 Quads (about 330 million BTU per person) per year. If the world population reaches 9 billion in 2050, and each person requires 330 million BTU per year, the world energy demand would be about 3,000 Quads per year, or about six times the current world energy consumption. One might argue that assuming that everyone will become as energy hungry as modern Americans is absurd because world citizens will choose to practice greater conservation, efficiency, and simplicity because of cultural differences or because of energy supply difficulties. On the other hand, one might argue that future citizens will need at least as much energy as Americans currently use because of the need for more energy for activities such as growing food on less-productive land and extracting mineral resources from increasingly lean deposits. These increases could cancel out reductions in energy demand achieved through increased conservation, efficiency, and simplicity.

It is instructive to assess the energy resources required to produce 3,000 Quads per year. In order to get a feel for the quantities required, consider the facilities needed to produce 3,000 Quads totally from each energy production option. Of course, the energy production serving future populations will be derived from a mix of sources, but the calculation illustrates the scope of the effort needed if everyone were to reach current U.S. levels of consumption. Here are the numbers, along with some comparisons:

- Crude oil: around 500 billion barrels per year (the remaining world reserve estimates range from 1,000 to 2,000 billion barrels)

- Coal: around 120 billion tons per year (the U.S. currently consumes slightly more than 1 billion tons per year)
- Land to grow biomass (60% conversion to biofuel efficiency): more than 30 billion acres (the continental U.S. land area is 1.9 billion acres)
- 1,000 MWe nuclear power plants (90% availability and 40% thermal to electrical efficiency*): around 45,000 plants (the U.S. now has around 100 plants)
- 2.5 MWE wind machines (30% availability): around 50 million machines**
- Land for 30% efficient photovoltaic electrical systems: around 200 million acres**

(*Note: The total world energy requirement of 3,000 Quads per year is primary energy. An advanced 1,000 MWe nuclear plant produces about 2,500 thermal megawatts.)

(**Note: For wind, hydropower and photovoltaics, each directly produced electrical watt is equivalent to about 2.5 watts of thermal energy consumed in a thermal plant.)

The assessment presented above serves only to illustrate the magnitude of the problem of satisfying future energy appetites. However, these numbers permit you to make your own assumptions and to assess the consequences of those assumptions. For example, if you assume that world per capita energy consumption in 2050 will be one-fourth of current U.S. per capita consumption and also assume coal will provide one-fourth of that energy, then the estimated annual coal consumption is $120 \text{ billion tons} \times 0.25 \times 0.25 = 7.5 \text{ billion tons}$, or 7.5 times current U.S. consumption.

14.8 The Bottom Line

World population will grow in the future, and world energy demand will grow even faster than population growth as more people want more energy to support better lifestyles. Satisfying these future energy demands will be difficult because of their magnitude and because of the depletion of traditional energy resources. The total energy requirements will be reduced somewhat if birth rates continue to decrease, but wise energy policy is to expect and prepare for large increases in population and in energy requirements in the future.

References

1. Population Reference Bureau “2007 World Population Data Sheet” at <http://www.prb.org>.
2. U.S. Census Bureau web site at <http://www.census.gov>.

Exercises

- 14-1. The death rate of the world population was around nine deaths per 1,000 people in 2000. It was dropping at around 10 percent per year. Why was it dropping? What change do you expect to see in the rate of decline in the death rate? Why?
- 14-2. A country’s population is composed of two ethnic groups that do not intermarry. The population of group A is 90 percent of the total population and is decreasing at 1 percent per year. The population of group B is 10 percent of the total population and is increasing at 2 percent per year. If current rates of change persist, how long will it be before each group has the same population?
- 14-3. The children’s riddle of the French lily pond is as follows: Lilies growing on the surface double every year. Fifty years after lilies

started growing in the pond, they cover half of the surface. How long will it take to cover the whole surface?

- 14-4. Estimate the number of 5 MWe wind turbines that will be needed in 2050 if the world per capita energy consumption is one-fourth of current U.S. per capita consumption and these wind turbines provide 10 percent of that energy.

15

Residential Energy Use

The Main Points

- One-fifth of the energy produced in America is produced to serve residences.
- Over two-thirds of the energy produced to serve residences is used to generate and deliver electricity (includes losses in production and delivery).
- Delivered electricity and natural gas each supply slightly over 40 percent of residential energy.
- Technologies are available to reduce the energy needed in residences. These include:
 - More efficient appliances
 - More efficient lighting
 - Better insulation
 - More efficient glazing on doors and windows
 - Heat recovery from drain water
 - Geothermal (or ground effect) heat pumps (extract or deposit energy in subsurface regions)
 - Energy storage in thermal mass (heat or cool a mass of material and use to extract or deposit heat as needed)
 - Building designs that capture or exclude heat input as needed
- Technologies are available to replace purchased energy with energy produced on-site. These include:
 - Solar space heaters (possibly with energy storage for use when sunlight is unavailable)

- **Solar water heaters**
 - **Photovoltaic systems**
 - **Wind turbines for electrical or mechanical energy
(mainly on farms)**
- **Residents can make lifestyle choices that minimize energy use**

15.1 Introduction

Citizens have direct control of the quantity of energy that they consume in their residences (along with their energy use for personal transportation). Additional indirect energy must be used to provide them with goods, services, and infrastructure. This chapter deals with direct energy consumption in residences.

Homeowners can take steps to reduce residential energy consumption without major impacts on comfort. Reducing energy consumption usually requires capital expenditure, but this is offset over time by reduced annual energy costs.

American residences consumed about 21 Quads, or 21 percent, of all energy produced in the country in 2009. This consumption, along with the commercial sector consumption of around 17 Quads, results in total consumption for buildings of around 38 Quads, which is the largest share of total U.S. energy consumption. Measures to reduce energy use in buildings are thus important and are increasingly receiving attention from the federal and state governments, from builders, from property owners, and from real estate investors.

15.2 Residential Energy Consumption

15.2.1 Total Consumption

Residential energy use has remained rather constant since 2000, with primary consumption ranging from 20 to 21 Quads per year. It is important to appreciate the difference between *delivered* energy consumption and the *primary* energy production required to provide that quantity of delivered energy. Delivered residential energy is the energy actually used in the residence, regardless of the amount of energy initially consumed to provide the delivered energy. Primary energy is the total energy needed to provide delivered energy. The difference between the two is due to energy losses between primary consumption and delivered consumption. Electrical energy production in thermal plants results in the unavoidable loss of about two-thirds of the energy released from the fuel to produce the electricity (see Section 2.6). Additional electrical losses occur during transmission.

Table 15-1 and Figure 15-1 show the uses of residential energy.

Table 15-1. 2006 Residential Energy Use¹

Use	Delivered		Primary	
	Quads	Percent	Quads	Percent
Space Heating	4.78	44.3	5.51	26.4
Space Cooling	0.85	7.9	2.70	13.0
Water Heating	1.67	15.5	2.59	12.5
Lighting	0.76	7.0	2.41	11.6
Electronics	0.53	4.9	1.69	8.1
Refrigeration	0.47	4.4	1.50	7.2
Clothes washers, dryers, dishwashers	0.46	4.2	1.22	6.2
Cooking	0.48	4.4	0.98	4.7
Computer	0.07	0.6	0.21	1.0
Other	0.34	3.2	0.76	3.6
Adjustment	0.37	3.5	1.19	5.7
Total	10.79	100	20.83	100
Note: The adjustments are for discrepancies in the data sources.				

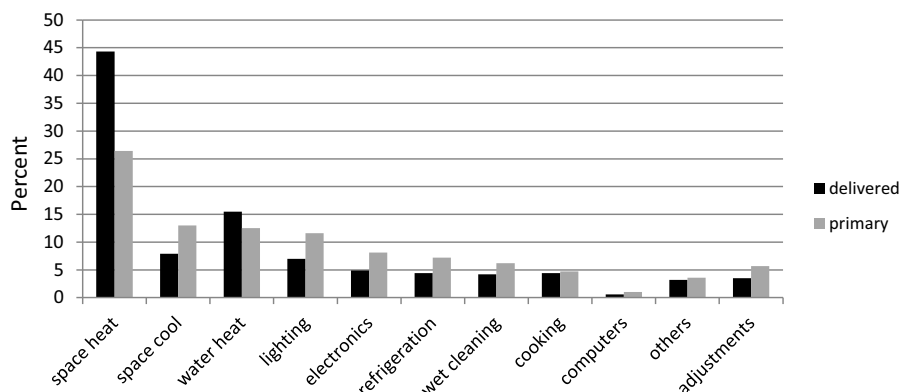

Figure 15-1. Residential Energy End Uses (2006)

It should be noted that other U.S. Department of Energy reports provide data on residential energy use, and the reports show slight differences in the data (for example, Reference 2). Since the data are presented here to provide a feel for energy use rather than for quantitative analysis, no attempt was made to judge or reconcile the sources.

The energy end use data show that space heating is the largest delivered energy user by a wide margin. Delivered energy for water heating is the second largest user of delivered energy (about one-third as great as space heating).

Delivered energy use is more important to residents who pay the bills for the energy they use. Primary energy use is more important when considering the nation's energy use and the consequences of producing that energy. In terms of primary energy end use, space heating is still dominant, but only around twice as great as three other applications: space cooling, water heating, and lighting.

Electrical energy consumption in residences deserves special attention. Around two-thirds (69 percent) of the primary energy production for residential use is for electricity. Energy losses in producing and delivering the electrical energy used in homes are about 10 Quads. In 2006, residential

electricity consumption required 14.7 Quads of primary energy to produce 4.6 Quads of delivered electricity.

The distribution of electricity among the various residential end uses appears in Table 15-2.

Table 15-2. Residential Electricity Use (2006)³

End Use	Delivered Energy Quads	Primary Energy Quads
Space Heating	0.33	1.05
Space Cooling	0.85	2.70
Water Heating	0.42	1.34
Lighting	0.76	2.41
Electronics	0.53	1.69
Refrigeration	0.47	1.50
Clothes washers and dryers, dishwashers	0.38	1.22
Cooking	0.23	0.72
Computers	0.07	0.21
Others	0.19	0.61
Adjustments	0.37	1.19
Total	4.61	14.65
Note: The adjustments are for discrepancies in the data sources.		

These data provide a snapshot of residential electricity consumption and reveal applications where consumption reduction steps would have the largest benefit-to-cost ratio. For example, newer air conditioning systems can provide the same cooling as older units, but use as little as half as much energy. Refrigerators, lighting, and clothes dryers all use significant fractions of residential energy and newer, energy efficient systems are available for each of these applications. A 20 percent reduction in energy use in these three applications alone would save about 7 percent of the primary energy used to produce electricity for residential use.

As mentioned in Section 14.7, there are about 110 million U.S. households, and they use about 11 Quads of delivered energy per year (2008). The aver-

age delivered energy use per household is about 100 million BTU per year. To put this energy consumption into perspective, note that 100 million BTU could raise the temperature of 1 million pounds of water by 100°F.

15.2.2 Consumption by Energy Source

Electricity, natural gas, fuel oil/kerosene, propane, and renewables provide residential energy. In the early twenty-first century, the delivered residential energy consumption was around 11 Quads. The contribution of each source of delivered energy appears in Figure 15-2. Natural gas and electricity each provide a little over 40 percent of delivered residential energy. Fuel oil and liquefied petroleum gas (mainly propane) account for 10 percent, and renewables account for the balance of delivered residential energy.

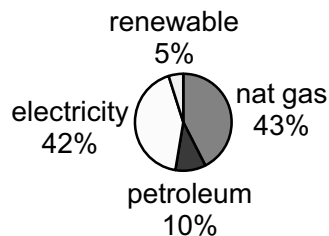

Figure 15-2. Residential Delivered Energy (2009)

Energy losses in producing and delivering the electrical energy used in homes were about 10 Quads.

Figure 15-3 shows the contributions of each primary energy source used to produce residential energy. Note that two thirds of the primary energy production for residential use is for electricity.

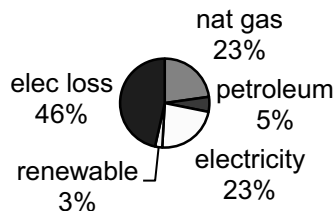

Figure 15-3. Residential Primary Energy (2009)

15.2.3 Heating and Cooling

American homes use over half of their delivered energy for space heating and cooling. Approximate assessments of heating and cooling energy needs are given by metrics called heating degree days and cooling degree days, defined as follows:

- Heating Degree Days (HDD) = sum of (days when the average temperature is below 65°F) × (65 minus the average temperature on that day)
- Cooling Degree Days (CDD) = sum of (days when the average temperature is above 65°F) × (Average temperature on that day minus 65)

For example, a day with an average temperature of 40°F contributes 25 Heating Degree Days to the annual total.

Yearly average HDD and CDD for several U.S. cities are shown in Table 15-3.

Table 15-3. Heating Degree Days and Cooling Degree Days⁴

City	Mean Temperature °F	HDD	CDD
Hartford, CT	50.2	6104	759
Laramie, WY	40.4	9038	71
Denver, CO	50.1	6128	696
Knoxville, TN	59.5	3531	1527
Atlanta, GA	62.1	2827	1810
Houston, TX	68.8	1525	2893
Miami, FL	76.7	149	4161

These data show the large variations in heating and cooling requirements across the U.S.

15.3 Space Heating and Cooling Systems

15.3.1 Space Heating Furnaces and Boilers

Home furnaces and boilers use natural gas, oil, or propane to heat air in the living space or to heat water that subsequently transfers heat to air in the living space. A metric called the “annual fuel utilization efficiency,” or AFUE, defines their efficiency. The AFUE is the ratio of the output heat from a furnace or boiler compared to the total energy consumed by that furnace or boiler. Modern high-efficiency furnaces and boilers have an AFUE of over 90, up from around 60 a few decades ago⁵.

15.3.2 Air Conditioners

Three types of cooling systems are used for home air conditioners: vapor compression systems, vapor absorption systems, and open-loop evaporative systems. The vapor compression type is the most common by a wide margin. All three systems remove heat from the surroundings by the evaporation of a fluid and are labeled phase-change systems. Appendix K addresses the principles of operation for all three types.

As discussed in Appendix K, a performance measure called the SEER (Seasonal Energy Efficiency Ratio) rating provides an indication of the energy efficiency of cooling with air conditioners and heat pumps. The SEER rating indicates the energy removed with the system (in BTUs) divided by the energy input to the system (in watt-hours) on a “typical” day. Manufacturers are required to meet minimum SEER requirements in their products. SEER ratings also provide consumers with a basis for comparing different products. Products that have SEER ratings at some level above the minimum requirement are designated “ENERGY STAR” systems and are so labeled.

Energy standards change over time, with higher efficiencies mandated as technology evolves and energy conservation concerns increase. In 2006, the minimum SEER requirement was 13, and the ENERGY STAR rating required a SEER of 14. Newer designs provide SEER ratings as high as the low twenties.

The efficiency of an air-source air conditioner or heat pump depends on the operating conditions (mainly ambient outdoor air temperature) as well as system design features. The efficiency at a specific operating condition is given by the Coefficient of Performance (COP), defined as the energy absorbed from the cooled space (for air conditioners) or energy delivered to the heated space (for heat pumps in the heating mode) divided by the energy delivered to the system. Both energies are in the same units, so COP is dimensionless. Typical COP values for current air-source air conditioners are 3 to 5, indicating that 3 to 5 units of heat are removed from the cooled space for every unit of energy supplied to the air conditioner.

The vapor compression and vapor absorption types are closed systems, in which all fluids are contained and circulated. The refrigerant in closed systems must be re-liquefied (condensed) after evaporation. The energy to drive the process is provided by electricity for the compressor in vapor compression systems and primarily by heating to separate the refrigerant from the solvent in vapor absorption systems.

In vapor compression systems, re-liquefaction is accomplished by compressing the refrigerant to re-liquefy it and then cooling the liquid refrigerant by heat transfer to the environment (see Figure 15-4). In vapor absorption systems, re-liquefaction is accomplished by dissolving the refrigerant in a solvent, heating the mixture to separate the refrigerant and the solvent, and then cooling the refrigerant by heat transfer to the environment.

There are two main variants of the vapor absorption process. One uses two components: a refrigerant and an absorber fluid. The other uses three components: a refrigerant, an absorber fluid, and an inert gas. The two-component version requires a pump that consumes a relatively small amount of energy in addition to the heat energy supplied. The three-component version does not require a pump. Using heat to power a refrigeration cycle is counter-intuitive, but it works at the expense of requiring a system with somewhat greater plumbing complexity than a vapor compression system. Vapor absorption systems can operate with any heat source, including solar energy (see Appendix K for details).

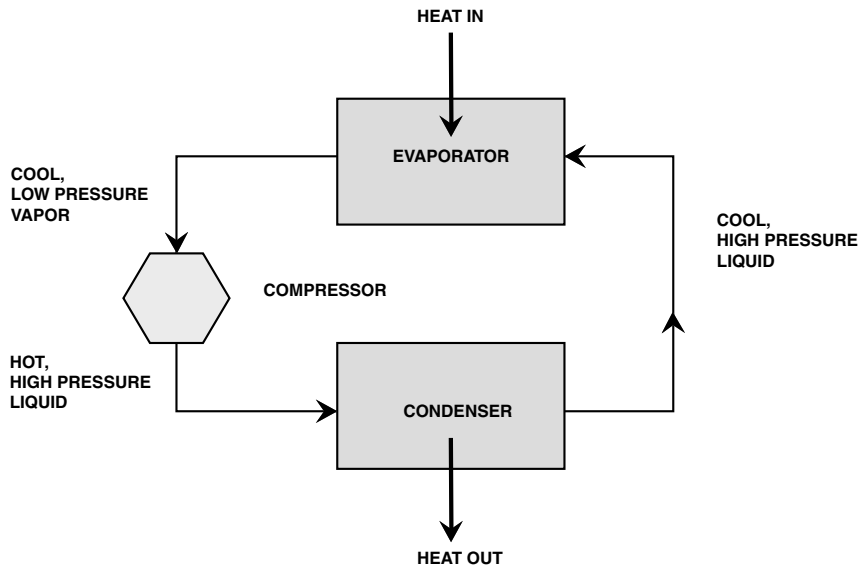

Figure 15-4. Vapor Compression Air Conditioner or Heat Pump

Open-loop evaporative coolers, often called “swamp coolers,” are simple systems that use blowers to pass ambient air over a wick that is wetted with water (see Figure 15-5). Evaporation rates increase with increasing ambient air temperature and decreasing humidity. Consequently, these coolers are effective only in hot, dry climates such as occur in the U.S. Southwest.

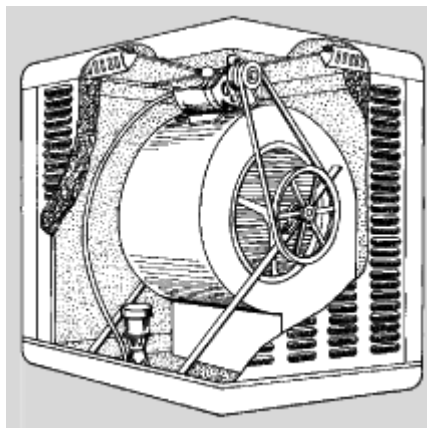

Figure 15-5. An Evaporative Cooler

A summary of the features of the three types of systems used for home air conditioning is given in Table 15-4.

Table 15-4. Features of Phase-Change Coolers

System Type	Open or Closed	Fluid	Energy Supply	Relative Complexity
Compression	C	single refrigerant	mechanical	intermediate
Absorption (two-component)	C	refrigerant, absorber	heat, low power pump	intermediate
Absorption (three-component)	C	refrigerant, absorber, inert gas	heat	high
Evaporative	O	water	low power fan	low

There is growing interest in the expanded use of vapor absorption systems. The attraction lies mainly in the ability of the system to use solar heating and thereby reduce or eliminate the need for grid electricity for air conditioning.

A novel cooling approach is nighttime production of ice to be used the following day for cooling⁶. This approach uses electricity when the grid demand is low and results in lower cost in regions where time-of-day pricing exists.

Subsurface regions with cool year-round temperatures may be used directly as heat sinks to cool air for living space. Tubes called earth cooling tubes carry air or a heat transfer fluid into sub-surface regions, where it is cooled before returning to the surface and used for cooling the living space.

15.3.3 Heat Pumps

Heat pumps can provide heating as well as cooling. In the cooling mode, heat is extracted from the living space by the evaporator. In the heating

mode, heat is transferred to the living space by the condenser (see Figure 15-4).

Heating with heat pumps is much more efficient than resistive (Joule) heating. Since heat pumps use electrical energy to draw heat from a cooler environment, the total heat energy supplied includes energy from electricity, and the heat drawn from the environment. The heat provided by heat pump systems is several times the electrical energy used.

Currently, most heat pumps use ambient air to supply heat to the evaporator for operation as a heater. However, the ambient air is coolest in winter, thereby reducing the heat pump's ability to extract heat. For this reason, air-source heat pumps are not used in cold climates. An exception is dual-mode systems that include a heat pump and a gas furnace. In these systems, the heat pump provides heating until the air temperature drops too low for efficient operation. At that point, the operation switches to heating with the gas furnace.

Heat pumps can increase their heating capability by drawing energy from locations where the temperature is higher than the winter air temperature. So-called ground source heat pumps or geothermal heat pumps⁷ use buried heat exchangers to draw heat energy from sub-surface regions, where temperatures are higher than ambient air temperature in winter. (For summer cooling, a ground-source heat pump dumps heat into sub-surface regions, where temperatures are lower than ambient air temperature.) Figure 15-6 illustrates the basic ground source heat pump.

Figure 15-7 shows the general features of seasonal soil temperature variations. Note that variations decrease with depth and they lag behind surface temperature variations. Typically, soil temperatures in the U.S. remain essentially constant year-round at depths of around 30 feet.

15.3.4 Solar Heating and Heat Dumping

Solar heating is very simple in principle. The first goal is to capture enough solar energy for immediate needs. The second goal is to capture and store

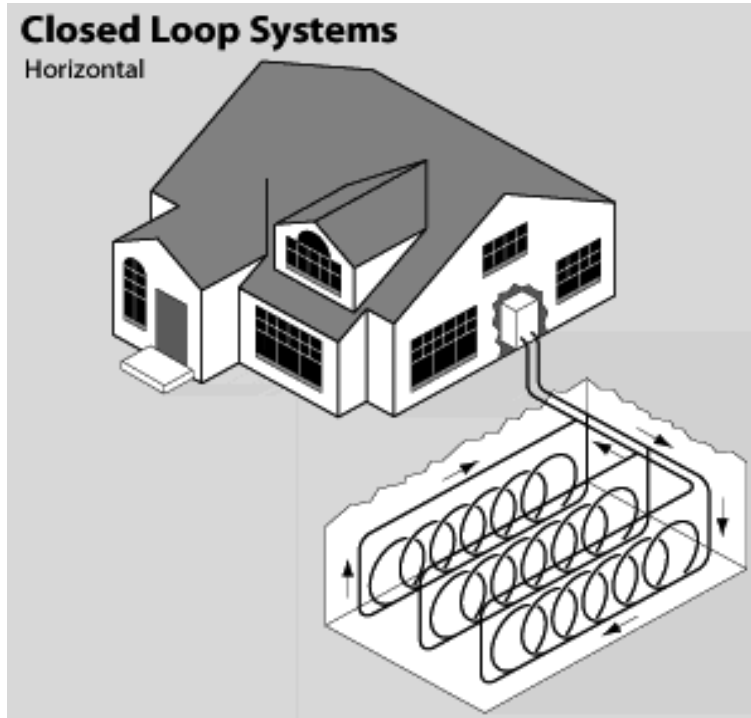

Figure 15-6. A Geothermal Heat Pump Layout (courtesy of U.S. Dept. of Energy)

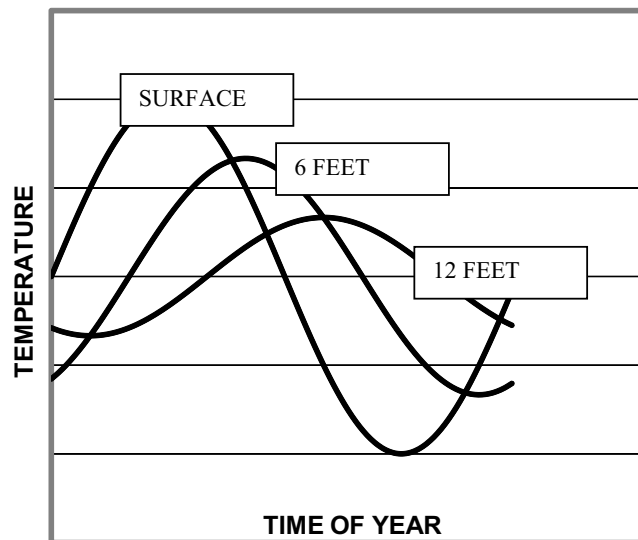

Figure 15-7. Annual Soil Temperature Variation at Various Depths

additional solar energy for future use when there is no incoming sunlight. The medium in which heat is stored is called a thermal mass. Heat dumping is the transfer of heat from a warmer thermal mass to cooler air or the transfer of heat from warmer air to a cooler thermal mass.

Daytime solar heating may be greater than is needed to warm a home adequately during the day. If this excess energy is stored during the day, it can be released at night when heat is needed. Energy storage involves heating material to a temperature above the desired temperature for the living space. At night, this heat is transferred to the air in the living space.

Similarly, nighttime air in summer is often cooler than the desired temperature for living spaces in summer. This cool air can be used to lower the temperature of a mass of material. During warm daytime hours, air in the living space is cooled by dumping heat to the cooled thermal mass.

Thermal mass is simply some material or structure that can store or deliver heat as needed. Walls, ceilings, floors, and furniture all contribute thermal mass, but the term is usually limited to separate systems designed for heat storage and for heat exchange with air from the living space. Thermal mass systems are most conveniently installed during initial construction, but retrofitting is also possible.

A thermal mass heating system that combines heat capture and storage and can be incorporated in new homes is the Trombe wall⁸. The Trombe wall is basically a south-facing wall located behind glass (see Figure 15-8.) The wall provides a thermal mass that can store heat. Materials used in Trombe walls include wood, stone, concrete, adobe, and water tanks. The energy capture is due to the greenhouse effect (see Chapter 19). That is, incoming radiation from the sun passes readily through glass, but the glass is less transparent to re-radiation from the wall. The wall—and the air in the space between the wall and the glass—are heated when the sun is shining. Trombe walls also have vents to the rest of the building at the top and bottom. Warm air rises and passes through the top vent and is replaced with cooler air entering through the bottom vent. Stored heat in the wall is available for transfer to the living space when the sun is not shining.

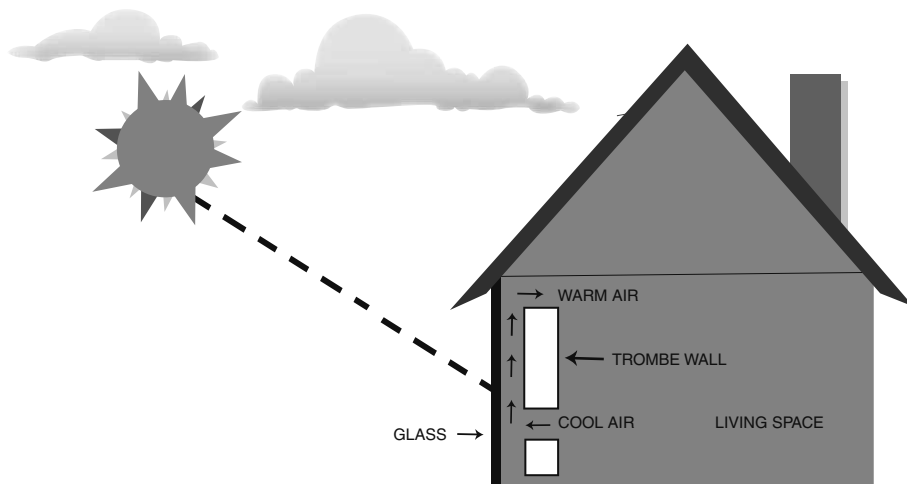

Figure 15-8. A Trombe Wall

Thermal mass systems may also be separate from building structures such as Trombe walls. These systems include an insulated container of some sort that holds thermal mass material, a means for transferring heat between the environment and the thermal mass, and a means for transferring heat between the thermal mass and the air in the living space. The container may be located in the building or sunk into the ground near the building. Thermal mass systems are heavy, so installations inside buildings are located at ground level.

Water and rocks are suitable thermal mass materials. Both are inexpensive and readily available. Because of water's large specific heat capacity and good heat transfer properties, water systems are smaller than rock systems of comparable capacity. Rock systems use blowers to pass air over the rocks during heating and cooling. The design and operation are simple, but use of uniform rock size so as to leave space for air flow is crucial. In water systems, it is necessary to transfer heat to or from air in the living space without causing excess humidity. Water-to-air heat exchangers can provide this capability. Water systems also must be protected from freezing, and they must be cleaned and treated to prevent algae buildup. Figures 15-9 and 15-10 show typical thermal mass systems.

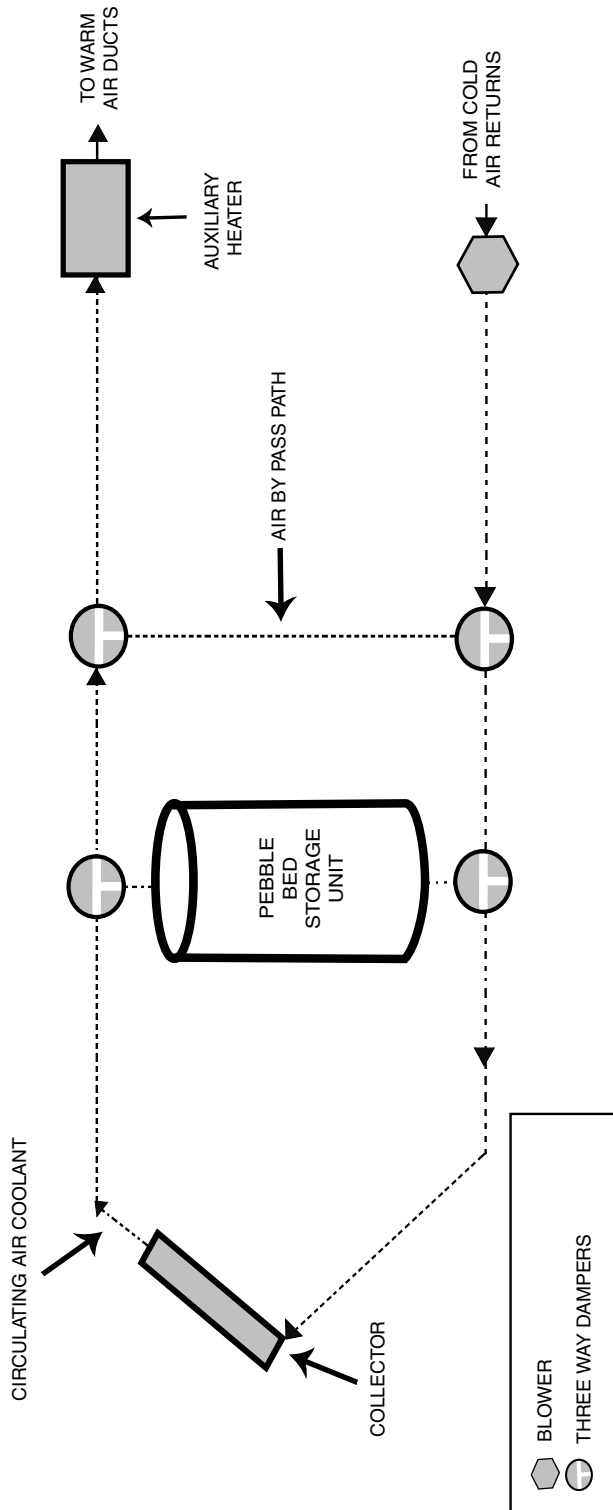

Figure 15-9.

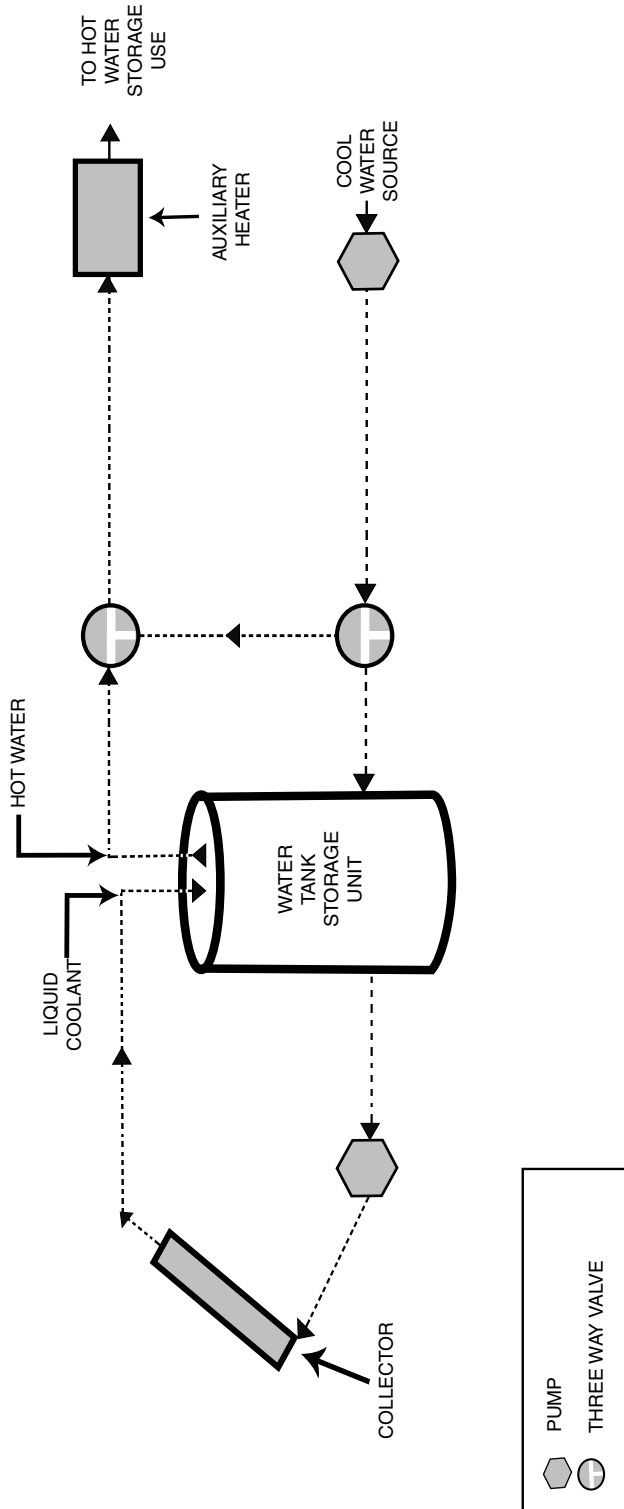

Figure 15-10.

A phase-change thermal mass system for heating is also possible. These systems require the use of a material that melts and freezes at a temperature slightly above the desired temperature for the living space. Glauber's salt (sodium sulfate decahydrate) melts and freezes at about 90°F and is potentially useful for energy storage. If solar heat can raise the salt to 90°F, then the salt will melt by absorbing heat at constant temperature. It can then release energy upon freezing due to heat transfer to air with a temperature below 90°F. The advantage of a phase-change thermal mass is the large amount of energy absorbed upon melting and released upon freezing, thereby minimizing the volume of thermal mass required.

We have seen the average delivered energy consumption in American residences is about 100 million BTU per year. About 60 million BTU per year provides space heating and water heating. We have also seen (Chapter 5) that the average solar insolation in the U.S. ranges from 1,100 to 1,800 BTU per day per square foot. However, solar insolation is lowest in winter, when heating is needed. Winter insolation in regions that need significant heating ranges from 25 to 40 percent of summer insolation (see Figure 15-11 for data for two selected cities, Atlanta and Hartford). Mid-winter insolation in the northern U.S. is only 400 to 600 BTU per day per square foot. The combination of a colder climate and lower insolation in the northern U.S. makes solar heating much less practical than in regions with a milder climate.

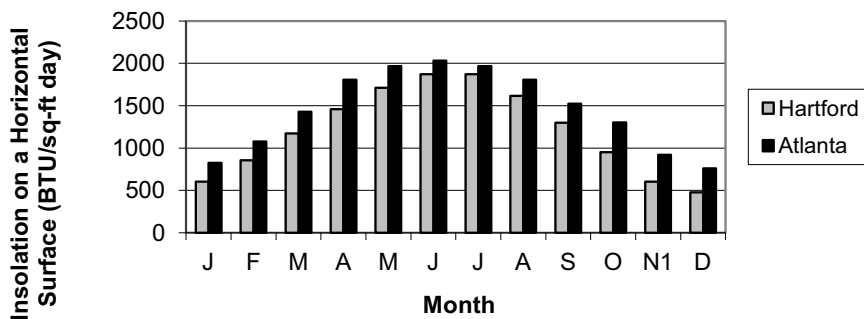

Figure 15-11. Insolation in Hartford and Atlanta

15.4 Water Heaters

Unlike space heating, water heating is needed year-round. According to the U.S. Department of Energy,⁹ energy for water heating amounts to over 15 percent of residential energy consumption, and 80 to 90 percent of that energy leaves through the drains. This loss amounts to over 2 percent of total U.S. energy production.

Traditional water heaters in the U.S. are tanks with gas or electric heaters and a storage capacity of 40 to 80 gallons. These tanks are insulated, but there is unavoidable energy loss from the stored hot water.

Hot water must travel through pipes from the water heater to the point of use. When flow stops, trapped hot water in the pipes cools by heat transfer to the surroundings, thereby wasting the energy used initially to heat the water.

Various methods are capable of reducing energy losses in water heaters and delivery systems, but they require capital investment.

Heat recovery systems can be installed to reduce energy lost in drains.⁹ For example, a heat exchanger can be used to transfer drain water heat to fresh water. Storing the heated fresh water in an insulated vessel and using it to feed the main water heater reduces the energy required in the water heater. See Figure 15-12.

Tankless, or on-demand, water heaters address the losses in storage. They use gas or electric heaters to raise the water temperature as it passes through the heater. These systems require high power capability in order to deliver the energy fast enough, but they eliminate hot water storage and the energy losses associated with storage.

Heat pump water heaters are available, and they provide efficiency advantages over direct heating. They use the same principle as heat pumps used to heat homes. Heat pump water heaters are usually located indoors (typically in a garage), but must be placed in locations with ample surrounding open

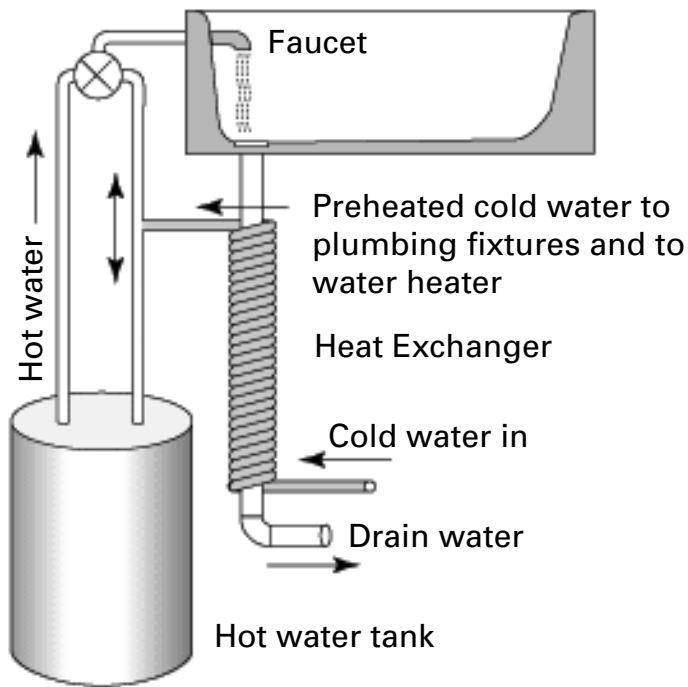

Figure 15-12. Drain Water Heat Recapture (courtesy of U.S. Dept. of Energy)

space so as to avoid excessive cooling of the air. Recall that heating with an air-source heat pump requires drawing energy from surrounding air and the efficiency of this process decreases as air temperature decreases.

Solar water heating is another option for homeowners, especially in summer when insolation is greatest. Delivered energy use for water heating in 2006 was about 1.67 Quads for around 110 million households, or an average of 15 million BTU per household per year. Since the need for hot water is fairly constant throughout the year, the average monthly and daily household uses are fairly constant with values of about 1.3 million BTU per month and 42,000 BTU per day. For example, in a location with an insolation of 1,000 BTU per square foot per day, a horizontal collector with 30 percent efficiency would need about 135 square feet of surface area to provide adequate energy. In northern regions, winter insolation is about half as great, causing the surface needed for water heating to double (see Section 6.2.2 for details).

15.5 Lighting and Appliances

15.5.1 Lighting

We have seen that lighting accounts for about 2.41 Quads of residential primary energy use. Traditionally, home lighting has meant incandescent lights. Improved lighting efficiency (more light per watt of electricity) is possible with fluorescent lights or light-emitting diodes (LEDs).

Fluorescent lights have been available for many years. Until recently, they were in the shape of long tubes. Aesthetic concerns largely limited the use of these lights to commercial and industrial buildings. Residential use of fluorescent lighting is currently increasing rapidly with the introduction of screw-in compact fluorescent lamps (CFLs).

The main attractions of fluorescent lighting are its efficiency and longevity advantages over incandescent lights. A fluorescent lamp can produce as much light as an incandescent lamp with only about one-fifth as much energy, while lasting up to 10 times as long.

A disadvantage of CFLs is the higher initial cost than incandescent lamps, but reduced energy use and longer life result in lower lifetime cost. There is also a need to deal with the small quantity of mercury that is incorporated in fluorescent lamps. There is concern about the release of toxic mercury in homes as a result of breakage and in landfills as a result of disposal.

Light emitting diode (LED) use is currently limited to special applications, where their high cost can be tolerated. However, LED costs are dropping, and their competitive position is improving.

The U.S. government mandated increased energy efficiency of light bulbs, essentially requiring the phasing out of incandescent bulbs in favor of CFLs or LEDs. This ruling proved to be controversial, as some objected on the basis of infringement on personal freedom.

15.5.2 Appliances

The energy efficiency of appliances has improved greatly in recent years, and further improvements are imminent. For example, in the first month of his presidency, President Barack Obama directed the Department of Energy to accelerate its work on appliance efficiency standards¹⁰. The government promotes energy efficiency in two ways: by requiring manufacturers to meet efficiency standards and by informing consumers about the efficiency and lifetime energy costs for appliances. Consumer information activities include required “ENERGY GUIDE” labels on appliances. The ENERGY GUIDE provides estimates of energy use and energy costs. Appliances that significantly exceed minimum requirements receive an “ENERGY STAR” designation and are so labeled.

Of course, consumers can reduce energy use by purchasing ENERGY STAR appliances. Additional energy-reducing steps include purchasing appliances that use gas rather than resistive (Joule) heating, avoiding unnecessary capacity and use, reducing unwanted energy losses or gains, and providing regular maintenance. Some specific energy-reducing options for home appliances are as follows¹¹:

Refrigerators and Freezers

- Avoid purchasing units that are larger than needed
- Choose top-freezer refrigerators rather than side-by-side units
- Choose chest freezers rather than upright freezers
- Clean coils at least once per year
- Keep seals in good repair
- Locate refrigerators and freezers as far from heat sources (such as ovens) as possible

Ovens and Ranges

- Select gas rather than electric units (Gas heating is more efficient than resistance heating with electricity.)
- Select self-cleaning ovens because they have superior insulation, but use self-cleaning as infrequently as practical

Dishwashers

- Select models with booster heating to reduce the necessary water heater temperature settings
- Select models with multiple cycles for different size loads
- Select models with an air-dry feature

Clothes Washers

- Select front load washers, which use less water
- Use cool water when possible

Clothes Dryers

- Select gas rather than electric units
- Keep the filter clean
- Dry full loads
- Dry multiple loads consecutively
- Use air drying when possible

Appliance energy consumption also includes so-called phantom loads. A phantom load is energy consumption by an appliance when it is in a standby mode of operation. For example, appliances that respond to a remote control device must use energy continuously to be able to receive a signal to turn on. Residents can reduce phantom loads by unplugging appliances when they are to be idle for extended periods. The phantom load for individual appliances is typically small (a few watts), but residences usually have many such appliances, and the phantom loads continue around the clock. Estimates of residential phantom loads are as great as 10 percent of total residential electricity consumption.

15.6 Local Electrical Energy Production

Electricity can be produced locally for residences using photovoltaic (see Chapter 6 and Appendix I) or wind energy systems (see Chapter 8 and Appendix P). Photovoltaic panels, often mounted on rooftops, can produce significant quantities of electrical energy. The cost of these systems is still high, but costs are falling. Small wind turbines are also available for small-scale production of electricity, but their aesthetic impact often prohibits their use in urban or suburban areas. Wind turbines are potentially useful for farm applications, either to drive an electrical generator or as a source of mechanical energy to drive a pump for drawing well water for irrigation or other farm uses.

The electrical energy available from a photovoltaic system is equal to the product of the solar insolation, the solar-to-electrical conversion efficiency, and the surface area of the collector. For example, a collector with a horizontal surface area of 500 square feet and an efficiency of 30 percent will produce 150,000 BTU or 44 kw-hours of electricity per day in a location where the insolation is 1,000 BTU per day per square foot. At the current average cost of electricity, this production is worth about \$4 per day (average electricity cost is about \$.09 per kilowatt-hour).

Photovoltaic systems produce direct current (DC), but almost all residential applications require alternating current (AC). Conversion of DC to AC

requires the use of a device called an inverter, an essential part of a photoelectric system.

The power produced by a photovoltaic system will rarely match electrical needs continuously in a residence. Electricity from the grid can supplement or replace locally-produced electricity when needed. Excess locally-produced electricity can be fed into the grid and sold to the utility during daytime. This works to the benefit of the consumer and the utility. Local photovoltaic electricity production operates during the day when grid requirements are greatest. Availability of photovoltaic electricity from consumers reduces the required generating capacity for the utility. The sale of electricity produced during the day to a utility helps the consumer by offsetting expenditures for the nighttime consumption of grid electricity.

15.7 Building Features and Lifestyles

Homeowners can reduce residential energy consumption by using efficient heating systems, cooling systems, lighting, and appliances as described above. They can also reduce energy consumption by adopting smart building features and lifestyle habits.

Buildings designed to maximize solar heating in winter can reduce winter energy consumption. Placing large windows in south-facing walls that are unshaded in winter admits solar energy into the residence. The trick is to shade these windows in summer when heat is unwanted.

Overhangs, awnings, and strategically placed deciduous trees reduce summer heating. The sun is high in the sky in summer and low in winter. Figure 15-13 illustrates the concept. Use of small windows on other walls reduces unwanted energy transfers.

Of course, it is helpful to avoid energy transfer to the outside in winter or from the outside in summer by using adequate insulation, by thoroughly sealing cracks and openings and by using energy efficient glazing in doors and windows.

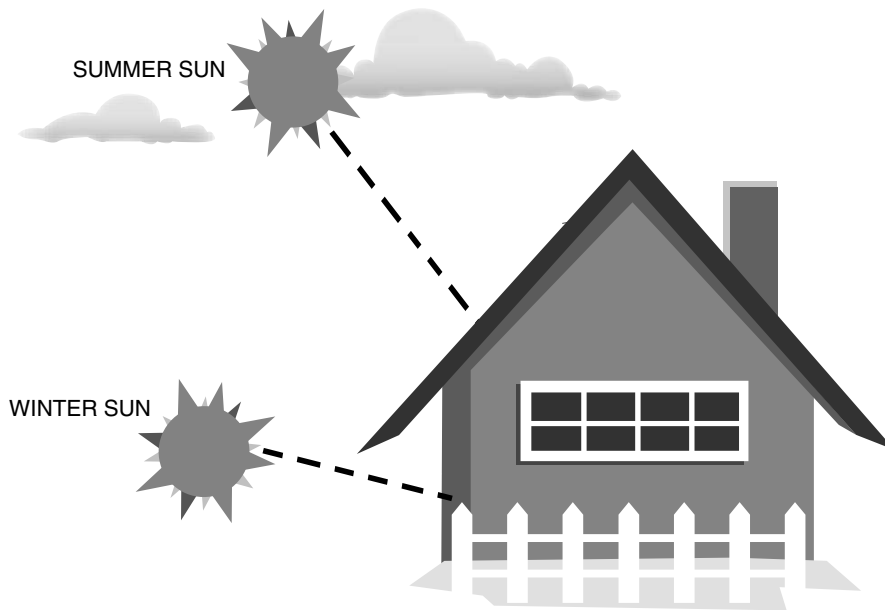

Figure 15-13.

Insulation's purpose is to reduce conduction heat transfer. Insulation is used in walls, attics, and beneath flooring to suppress heat transfer through these surfaces. The effectiveness of insulating material is specified by its "R value." The units for R values are $^{\circ}\text{F}/(\text{BTU per hr per square foot})$ where $^{\circ}\text{F}$ is the temperature difference across the insulator. Larger R values indicate greater resistance to heat transfer. For example an insulator with an R value of 30 would transfer one BTU per hour for each square foot of surface when it experiences a temperature difference of 30°F . Common residential insulating materials are fiberglass, cellulose, and foam. Recommended R values range from 11 for walls and floors in mild climates to 49 in ceilings below ventilated attic spaces in cold climates.

Fans can be efficient aids to comfort in warm weather. Applications include convection cooling of residents by exposure to moving air, removal of hot air from attics and drawing cool night air into homes.

Residences must exchange indoor air with outdoor air to maintain adequate indoor air quality. However, air entering or leaving the residence adds or removes heat energy from the home and can cause departures from desired indoor air temperatures. Drafts around poorly sealed windows and doors are readily observable, but additional air leakage can occur through holes and cracks in the building structure and in any ductwork that carries heated or cooled air into the living space. Energy savings can be achieved with engineered air replacement systems that incorporate heat exchangers to transfer heat between exhaust air and incoming air.

Windows are essentially “holes” in the building envelope. The Department of Energy states that 10 to 25 percent of residential energy consumption is due to heat transfer through windows¹². A number of design options are available for dealing with energy transfer through these “holes.” The frames and the glazing affect energy transfer. A metric called the “U factor” is used to quantify the heat transfer through glazing or through complete framed window structures. The U factor has units of BTU/(hr square foot °F). It is essentially the reciprocal of the R value used for insulation. Lower U factors indicate a greater resistance to heat transfer. U factors range from 1 for single-pane glazing to about 0.3 with gas-filled multiple-pane glazing. Corresponding R values are 1 to 3, much lower than typical insulation R values, confirming that windows are truly responsible for major residential energy losses.

Energy flow through window frames is essentially all by conduction. Frame materials with low thermal conductivity transfer less energy than those with higher thermal conductivity. Therefore frames made of wood or plastic allow less energy flow than those made of aluminum.

The main design approach for reducing conduction through glazing is to use two or even three panes separated by thin layers of stagnant gas. The gas may be air, but greater resistance to heat flow may be achieved with low-conductivity gases such as argon or krypton.

Radiation heat transfer through glass can be affected by the use of coating materials¹³. Thin, transparent coatings of certain metal oxides reflect infra-red radiation.

Lifestyle choices within residences can also influence energy consumption. We have all heard advice to keep our residences a few degrees cooler in winter and a few degrees warmer in summer and to accommodate these changes by dressing appropriately. Homeowners can also save energy by limiting heating and cooling to those parts of the residence that are in use. Closing doors and/or vents into rooms that are used infrequently can help. Some citizens choose to use supplementary heating of small areas only when they are occupied. Examples are electric bathroom heaters, small electric or kerosene heaters used for personal comfort and electric blankets. The low efficiency of these systems is offset somewhat by the limited space that they are called upon to serve.

15.8 Possibilities

Given the assortment of energy-reduction steps described above, one certainly must ask, “What is possible?” “What is affordable?” and “When can we expect to see significant reductions in residential energy use?” Some opinions appear below.

The useful life of most homes is many decades. Consequently, achieving improved energy efficiency exclusively in new homes will result in only slowly decreasing consumption. Efficiency upgrades in existing homes are needed along with improvements in new construction.

The U.S. Department of Energy has created a program called Building America¹⁴ to help in improving energy efficiency in existing and new homes. Its goals include reduction of energy use in existing homes by 20 to 30 percent and in new homes by 30 to 90 percent.

These advances are part of an ongoing effort to develop “Zero Energy Homes.” A zero energy home is one that has a net absence of energy inputs from external sources¹⁵. A zero energy home achieves this by:

- Minimizing energy losses through the design of the home (insulation, glazing, etc.)
- Minimizing energy need (efficient appliances, efficient lighting, etc.)
- Producing energy locally (solar heating, photoelectricity, etc.)

The idea is to reduce the energy needed by around 70 percent and to obtain the remaining 30 percent by local production. Since local electricity production will not match demand continuously, locally produced electricity that exceeds current demand will be fed into the grid. Conversely, energy will be extracted from the grid when demand exceeds the supply of locally produced electricity. The American Physical Society¹⁶ estimates that new, cost-effective zero energy homes will be feasible by 2020.

A home that approaches, but does not reach, the zero energy level is called a near-zero or ultra-low energy home.

The cost-effectiveness of investing in an energy-efficient home depends on several factors, including:

- Interest rate for borrowed money
- Incremental cost of unconventional building features
- Cost of conventional energy supplies
- Financial incentives offered by state and federal governments (see Reference 17 for current incentives)
- The potential increase in resale value

The U.S. Green Building Council has developed a certification program called Leadership in Energy and Environmental Design (LEED)¹⁸. LEED certification is granted to buildings that meet design criteria that reduce energy use and environmental degradation. LEED certification is the basis for financial incentives offered by some city and state governments¹⁹.

Predicting the speed and scope of a transition to energy-efficient homes suffers from many uncertainties. Attitudes must change along with changing economic and technical conditions. However, as energy costs inevitably rise and building design and local energy production technologies improve, energy-efficient homes will become increasingly attractive investments.

15.9 Commentary

It is likely that Americans will have strong reasons to reduce residential energy consumption in the future. Citizens have some direct control over their residential energy consumption (along with energy consumed for personal transportation). Many energy-reducing steps require capital expenditure. Examples include switching to compact fluorescent lamps for lighting, installing ground-source heat pumps for heating and cooling and solar collectors for heating or local electricity production. The range of costs and associated benefits is enormous. Investments in energy efficiency will reduce resource depletion immediately and will reduce personal expenditures eventually. The rate of recapture of money spent initially will increase as energy costs inevitably rise in the future.

References

1. U.S. Department of Energy: Energy Efficiency and Renewable Energy Report “2006 Buildings Energy Data Book, Table 2.1.5” at <http://buildingsdatabook.eren.doe.gov>.
2. U.S. Department of Energy Report DOE/EIA-0383(2009) “Annual Energy Outlook 2009” at <http://www.eia.gov> (Specify a site search for “Annual Energy Outlook 2009.”)
3. U.S. Department of Energy: Office of Energy Efficiency and Renewable Energy Report “2006 Buildings Energy Data Book, Table 2.1.5” at <http://buildingsdatabook.eren.doe.gov>.

4. National Oceanic and Atmospheric Administration web site at <http://cdo.ncdc.noaa.gov>. (Specify “heating and cooling degree days” in a site search then select “Monthly Normals.”)
5. Energy Efficiency and Renewable Energy Report “Furnaces and Boilers” at http://www.energysavers.gov/your_home/space_heating_cooling/index.cfm/mytopic=12530.
6. Ice Energy Company web site at <http://www.ice-energy.com>.
7. Virginia Tech web site at <http://www.geo4va.vt.edu>.
8. U.S. Department of Energy, Office of Energy Efficiency and Renewable Energy Report “Indirect Gains Trombe Walls” at http://www.energysavers.gov/your_home/designing_remodeling/index.cfm/mytopic=10300.
9. U.S. Department of Energy, Office of Energy Efficiency and Renewable Energy “Drain-Water Heat Recovery” at http://www.energysavers.gov/your_home/water_heating/index.cfm/mytopic=13040.
10. The White House Press Office, February 5, 2009 at http://www.whitehouse.gov/the_press_office/ApplianceEfficiencyStandards.
11. U.S. Department of Energy Report, “Energy-Efficient Appliances,” at http://www1.eere.energy.gov/buildings/appliance_standards/pdfs/26468.pdf.
12. U.S. Department of Energy, Office of Energy Efficiency and Renewable Energy *web site at* <http://www1.eere.energy.gov/consumer/tips/windows.html>.
13. U.S. Department of Energy, Office of Energy Efficiency and Renewable Energy report “Low Emissivity Window Glazing or Glass” at <http://www.energysavers.gov>.
14. “Building America” U.S. Department of Energy, at http://www1.eere.energy.gov/buildings/building_america/about.html.
15. Tait, A. “Zero Energy Homes” Appalachian State University, at http://energy.appstate.edu/sites/default/files/ZEH_report.pdf.
16. American Physical Society “Energy Future: Think Efficiency” at <http://www.aps.org/energyefficiencyreport>.
17. The Database of State Incentives for Renewable Energy at <http://www.dsire.org>.
18. LEED, U.S. Green Building Council, at <http://www.usgbc.org/LEED>.
19. Wikipedia “Leadership in Energy and Environmental Design” at <http://wikipedia.org>. (Specify a search for “Leadership in Energy and Environmental Design.”)

16

Commercial Energy Use

The Main Points

- Slightly over one-sixth of the energy produced in America is used by commercial buildings.
- Over 75 percent of the primary energy produced to serve commercial buildings is used to generate and deliver electricity.
- Delivered electricity and natural gas collectively supply around 90 percent of delivered energy for commercial buildings.
- Building owners and tenants have conflicting interests over energy requirements.
- Commercial energy use follows economic conditions.

16.1 Introduction

Commercial buildings use slightly more than one-sixth of U.S. energy. Commercial buildings and residential buildings together account for the largest share of U.S. energy consumption (around 38 Quads). Commercial sector energy use involves many of the same energy supplies as the residential sector, but the relative contributions of the various energy supplies are different. Furthermore, unlike the residential sector, the commercial sector encompasses many different types of enterprise, each with its own energy use pattern.

The commercial sector, as defined by the U.S. Department of Energy, includes all buildings that are not used for residential or industrial purposes. Even though the designation is “Commercial Buildings,” it includes buildings used for non-commercial purposes such as government buildings, schools, and churches.

The Energy Information Administration reports detailed information about commercial energy use¹. The Energy Information Administration’s report-

ing of energy use in commercial buildings differs from its reporting for other energy sectors due to different data collection procedures. For example, the Commercial Building Energy Consumption Survey (CBECS)² provides the most complete itemization of energy use by different types of commercial buildings, but its accounting covers only about three-fourths of energy consumption in the commercial sector. In spite of this sampling approach, the CBECS is the source of much of the information in other government reports and the information presented in this chapter.

Note: At the time of this writing (early 2012), the future of CBECS faces uncertainties. Publication of the 2007 survey was withheld because of concerns about the statistical significance of the data³. In 2011, work on the CBECS was suspended by the Energy Information Administration because of a budget reduction⁴, but there is congressional interest for restoring funding⁵. The government will certainly continue to publish energy data for the commercial sector, but these issues may complicate future access to current data by interested readers.

Since the technologies for reducing energy requirements and for producing local energy in residences are largely applicable to commercial buildings and are described in Chapter 15, they are not repeated here.

16.2 Commercial Energy Use

Commercial energy consumption is the smallest among the four energy use sectors. For example, in 2010, the commercial sector used about 18.34 Quads of primary energy, or about 18.8 percent of the total U.S. primary energy consumption of 97.77 Quads¹. The delivered energy was 8.49 Quads out of a total U.S. delivered energy consumption of 70.46 Quads, or 12 percent.

Figures 16-1 and 16-2 show the sources of delivered energy and primary energy. As with residences, electrical energy is the dominant primary energy

used in the commercial sector. Table 16-1 shows the uses of electricity in commercial buildings.

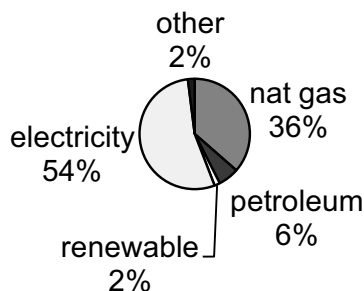

Figure 16-1. Commercial Delivered Energy (2010)

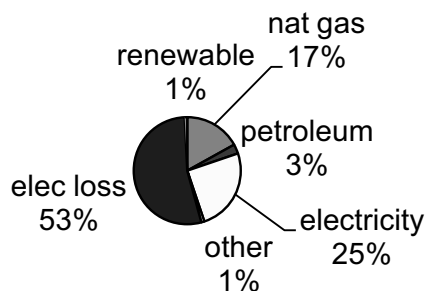

Figure 16-2. Commercial Primary Energy (2010)

Table 16-1. Commercial Electricity Use (2010)¹

Use	Delivered Energy Quads	Primary Energy Quads
Lighting	1.02	3.20
Space Cooling	0.58	1.82
Space Heating	0.18	0.55
Electronics	0.26	0.82
Ventilation	0.51	1.60
Water Heating	0.09	0.29
Refrigeration	0.39	1.23
Computers	0.21	0.66
Cooking	0.02	0.07
Other	0.65	2.03
Adjustments	0.69	2.15
Total	4.60	14.42

Note: Adjustments account for discrepancies in the data.

The uses of commercial energy are as shown in Figure 16-3. Space heating and lighting dominate delivered energy consumption. Space heating is the largest user of delivered energy, and lighting is the largest user of primary energy. Thus, energy-efficient design of heating systems and measures to minimize heat losses is the major focus for reducing delivered energy use, and efficient lighting is the major focus for reducing primary energy use.

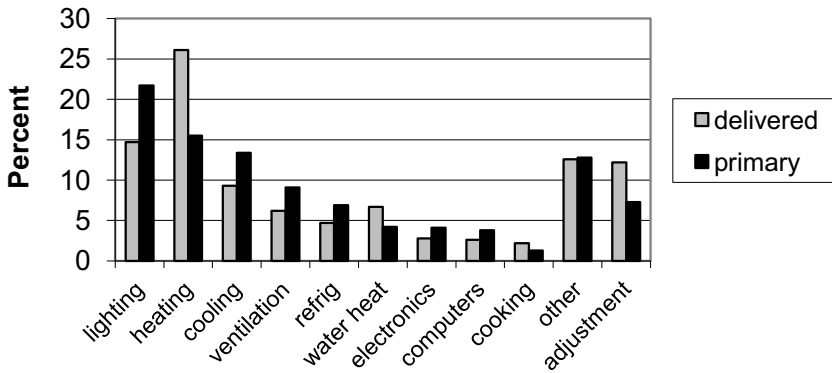

Figure 16-3. Commercial Energy End Uses (2008)

Figure 16-4 shows energy use in the various sub-sectors of the commercial sector. Mercantile and office uses dominate.

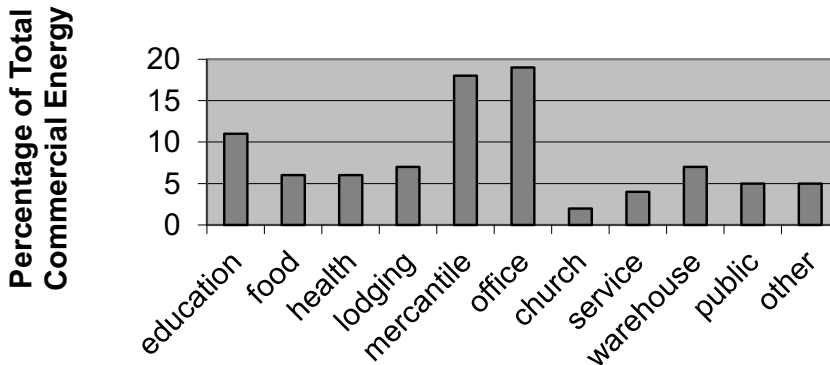

Figure 16-4. Commercial Energy Use by Sector

16.3 Capital Investment Incentives and Barriers

Investments being considered to minimize energy consumption in new or existing commercial buildings are subject to cost-benefit analysis. This analysis may be intuitive and subjective or rigorous and quantitative. In the past, only those involved in building or remodeling large buildings or groups of buildings had the in-house resources and capability to perform a rigorous, quantitative cost-benefit analysis. However, new software to aid in investment decisions is free, easy to use, and readily available⁶.

The stakeholders who may be involved in investment cost-benefit analysis and/or decisions are investors, builders, architects, engineers, and occupants.

Investment decisions depend on some or all of the following considerations:

- Incentives and regulations
- Interest rates on borrowed money
- Payback time for return on investment

Federal and state governments provide incentives for undertaking measures that are in the common good. Tax credits, tax deductions, and subsidies may be provided by governments to encourage business investments that reduce energy use, resource depletion, the trade deficit, and environmental degradation. In addition, governments sometimes include domestic job creation as part of the rationale for investment incentives.

The incentives offered by governments change often. This is especially true when the dominant political party changes and when a consensus develops among the citizens that change is necessary.

Governments also influence building energy use by regulations. In the past, building codes served to ensure that buildings were safe, harmonious with

other local construction, and durable enough to protect the new owners when the building changes owners. More recently, codes are being strengthened to ensure that buildings also minimize energy use.

There is no summary of incentives and regulations presented here. They are constantly changing, and they differ greatly from state to state. Those planning to construct or remodel commercial buildings are advised to check the latest information (such as is available in Reference 7) or to hire a qualified consultant. The government and various energy efficiency advocacy groups provide web sites with useful, free information. A web search for “codes and regulations for building energy” readily identifies these web sites.

Widespread adoption of energy-saving measures also faces barriers that inhibit implementation. Some of the more important barriers are as follows:

- Separation of building owner from energy expenditures. Often an investor builds a building for rent or lease to a tenant who will be responsible for energy expenditures. The owner is motivated to minimize initial cost, even if this action will result in higher ongoing energy consumption. The tenant often has little control over the design of the building and the consequent energy consumption required for the building.
- Ignorance. Failure to know what is possible, and how much energy-saving measures will cost, can inhibit the making of wise long-term decisions. The ease with which useful information is now available should reduce this problem.
- Apathy. It is tempting to do things in old, familiar ways. Implementing improved measures usually requires learning and decision-making.
- Shortsightedness. It is sometimes difficult to take the long view, especially in times of major political and economic uncertainty.

16.4 Reducing Commercial Energy Consumption

Energy conservation and efficiency measures for commercial buildings are basically the same as for residential buildings and industrial facilities. The idea is to reduce energy losses in the building itself and to use energy-efficient equipment. However, there are some different considerations for commercial buildings.

There is less opportunity for optimizing commercial building orientation to achieve solar heating than for residences. Also, window placement to influence energy transfer into or out of a building is often impossible in commercial buildings. Nevertheless, several energy-reducing measures are uniquely suitable for commercial buildings.

Many commercial buildings have large unshaded roof areas that are well suited for solar energy collectors for heating building air or water or for producing photoelectricity. Skylights, possibly with retractable shades, can augment building lighting. Geothermal heat pumps may be more cost-effective for commercial buildings than for residences, because the necessary excavation and subsurface installation of components is facilitated by the presence of heavy earth-moving equipment typically found at construction sites for commercial buildings.

16.5 Trends

In the early years of the twenty-first century, there are three dominant trends in commercial energy use:

- Energy intensity, as measured by energy used per square foot of commercial floor space, is decreasing.
- Total commercial energy consumption grew slowly until the economic downturn that began in 2008. Increased floor space offset decreases in energy intensity.
- Electrical energy continues to dominate commercial consumption.

16.6 Possibilities

As with residential buildings, one must ask about possibilities for energy saving measures in commercial buildings.

Efforts are under way to develop and implement zero energy building technology for the commercial sector. The Department of Energy, through its Building Technologies program⁸, has set a goal for commercial building energy use. The target is to have cost-effective zero energy commercial building technology available by 2025. As with residential buildings, a commercial building can achieve zero energy status by reducing energy consumption to some low point and then producing the balance of needed energy locally with renewable (most often solar) energy systems.

Leadership in Energy and Environmental Design (LEED)^{9,10} certification, mentioned in Chapter 15, applies to commercial buildings as well as to residences. Certification indicates the building meets criteria for minimizing energy use and environmental impact. LEED certification is available in many countries and has been applied to over 5 billion square feet of commercial building space.

Several important studies^{11,12,13} provide estimates of the potential energy savings in commercial buildings. The U.S. has over 70 billion square feet of commercial building space,⁸ and the average delivered energy use is around 110 BTU per square foot per year. The National Renewable Energy Laboratory¹¹ estimates energy reductions achievable with the application of several different levels of energy-saving measures. The estimate for bringing all commercial buildings into compliance with existing codes is a reduction in energy use to around 79 percent of current use. Application of all available current technologies would reduce energy use to around 45 percent of current use. The estimated additional benefit possible with the use of rooftop photovoltaic systems is a reduction to 13.6 percent of current energy use. These impressive improvements are only estimates, but they provide a feel for what is possible.

16.7 Commentary

Reducing energy use in buildings is a major opportunity and a major challenge. Buildings (residential plus commercial) account for the largest share of U.S. energy consumption, and reductions in use are technically feasible. But there is inherent inertia. Buildings last for decades. Owners will be reluctant to invest in improvements in existing buildings so long as the buildings continue to serve their purpose, and improvements fail to provide quick paybacks on investments. Development of cost-effective energy-reducing technologies for new buildings is predicted for the near future. Such a revolution in building technology will gradually reduce energy consumption as new buildings replace older buildings.

The bottom line is that optimism is justified, but improvements will be slow.

References

1. U.S. Department of Energy, Office of Energy Efficiency and Renewable Energy, “Buildings Energy Data Book” at <http://buildingsdatabook.eren.doe.gov>.
2. Energy Information Administration “Commercial Building Energy Consumption Survey” at <http://www.eia.doe.gov/emeu/cbecs>.
3. Energy Information Administration press release “2007 Commercial Buildings Energy Consumption Survey (CBECS) will not be released at http://www.srmnetwork.com/wp-content/EIA_CBECS_2007_Release_05-06-11.pdf.
4. Energy Information Administration press release “Immediate Reductions in EIA’s Energy Data and Analysis Programs Necessitated by 2011 Funding Cut” at <http://eia.gov/pressroom/releases/press362.cfm>.
5. Howard, B. U.S. Green Building Council report “Senate Panel Signals Support for Commercial Building Energy Consumption Survey” at <http://livabilitylaw/archives/2817>.
6. “Quick List of ENERGY STAR Resources for Buildings” at http://www.energystar.gov/ia/business/challenge/get_started/QuickListBusiness.pdf - 2010-06-02.

7. “Database of State Incentives for Renewable Energy” at <http://www.mrsolar.com/content/dsire.php>.
8. Crawley, D. *Statement before the Subcommittee on Economic Development, Public Buildings and Emergency Management*, Committee on Transportation and Infrastructure, U.S. House of Representatives, July 16, 2009. at <http://republicans.transportation.house.gov/Media/file/TestimonyEDPB/2009-07-16-Crawley.pdf>.
9. U.S. Green Building Council “LEED” at <http://www.usgbc.org/LEED>.
10. Wikipedia “Leadership in Energy and Environmental Design” at http://en.wikipedia.org/wiki/Leadership_in_Energy_and_Environmental_Design.
11. Griffith, B. et al, “Assessment of the Technical Potential for Achieving Net Zero-Energy Buildings in the Commercial Sector” *National Renewable Energy Laboratory Report NREL/TP-550-41957* December 2007.
12. American Physical Society report “Energy Future” at <http://www.aps.org/energyefficiencyreport/report/index.cfm>.
13. Grenade, H.C., et al. “Unlocking Energy Efficiency for the U.S. Economy” McKinsey and Company Report July 2009 at http://www.mckinsey.com/Client_Service/Electric_Power_and_Natural_Gas/Latest_thinking/Unlocking_energy_efficiency_in_the_US_economy.

Exercises

- 16-1. Discuss the relative possibilities for on-site energy production in residential buildings and commercial buildings.
- 16-2. Discuss similarities and differences between residential energy consumption and commercial energy consumption.
- 16-3. A local discount store has a roof surface area of 40,000 square feet. If the average annual solar radiation absorption rate is 1300 BTU/hour-square foot, how much electric power can be generated with rooftop photovoltaic systems with a conversion efficiency of 20 percent? How much is this electricity worth in a location where electricity costs 11 cents per kilowatt-hour?

- 16-4. As this book was being written, the U.S. and the world were experiencing a serious economic recession. Use the Internet to find out what has happened to commercial energy use in recent years. Discuss and interpret your findings.

17

**Industrial Energy
Use**

The Main Points

- **Around one-third of the energy produced in the U.S. is used for industrial activities.**
- **Industrial energy use has varied over a narrow range (around 30 to 35 Quads per year) in recent decades.**
- **Around half of fuel use in the chemical industry is for chemical feedstock.**
- **Manufacturing and mining use around four-fifths of all industrial energy.**
- **Eight industries dominate industrial energy use.**
- **Energy for heating consumes around three-fourths of industrial energy and represents the greatest opportunity for energy savings.**
- **Labor cost, energy cost, raw material cost, and regulations influence decisions on locations for new industrial facilities.**

17.1 Introduction

The industrial sector accounts for a large portion (around one-third) of total U.S. energy consumption, and it uses that energy in many different ways. Energy for transportation, residential, and commercial applications is almost all used for heating or mechanical work, and most of the energy used in these sectors is often supplied by one or two dominant sources. On the other hand, the industrial sector uses all energy sources and uses hydrocarbons for feedstocks as well as for fuel. End uses in industry include energy for electrolytic processes as well as for heating and mechanical work. Consequently, energy accounting in industry is more complex than in other sectors.

17.2 Consumption by Energy Type

U.S. industrial energy consumption in the late twentieth and early twenty-first century has varied over a narrow range. Total energy consumption in industry in 2008 was essentially identical to 1970 consumption in spite of growth in population and in gross domestic product. Three factors explain this behavior: increases in energy efficiency by industry, changes in products used by consumers, and departure of the U.S. industry to foreign countries (see Figure 17-1 for the recent history [through 2009] of primary energy consumption for U.S. industry¹. It should be noted that after the recession of 1980, industrial energy use remained nearly constant until 2009, when it dropped by around 10 percent as a result of another economic recession.)

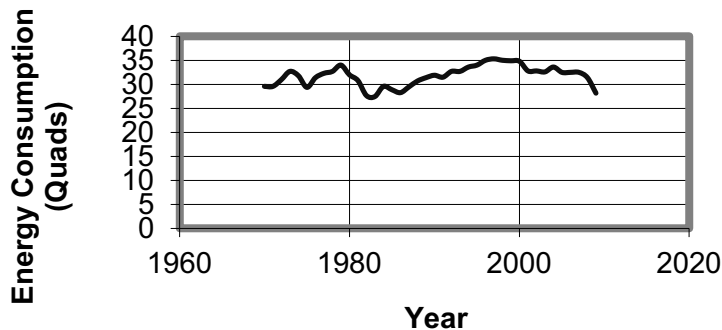

Figure 17-1. Industrial Primary Energy Consumption

The contributions of the industrial delivered and primary energy sources appear in Figures 17-2 and 17-3¹.

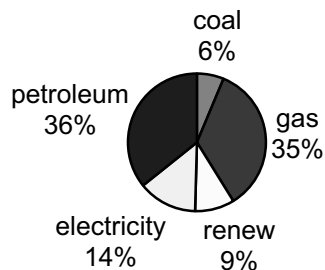

Figure 17-2. Delivered Industrial Energy (2009)

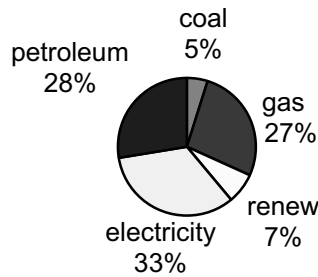

Figure 17-3. Primary Industrial Energy (2009)

The U.S. industry currently relies on fossil fuels. Natural gas and petroleum provide the greatest share of delivered industrial energy. Coal serves as the current main energy source for the production of electrical energy and as a source of coke used in iron making. If availability or environmental protection concerns cause curtailment of fossil fuel use, switching to alternative energy in processes where this change is possible will be difficult and expensive.

The trend to heavy reliance on natural gas by industry is because it is clean-burning, it is still plentiful, it is useful as a feedstock, and it is still cheap. Until a delivery network for natural gas was built, it was a nuisance that was burned (flared) to simply get rid of it. After pipelines from major natural gas sources to users were built in the second half of the twentieth century, use of this fuel grew rapidly in the industrial, residential, and commercial sectors. The government imposed regulations that encouraged this shift in its efforts to decrease emissions. Natural gas became the fuel of choice for many electric utilities.

17.3 Consumption by Use

Manufacturing and mining use the bulk of industrial delivered energy (around 80 percent). Figure 17-4 shows the ways in which this energy is used. (Fired systems shown in Figure 17-4 are heating systems, such as furnaces and dryers.)

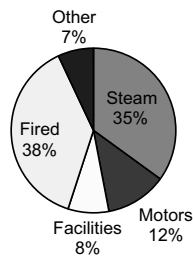

Figure 17-4. Energy Uses for Mining and Manufacturing

In the industrial sector, some resources suitable for energy production are used instead as feedstock. That is, their chemical constituents are used to make useful materials such as plastics, pharmaceuticals, and fertilizer. In accounting for primary energy consumption, feedstock materials are counted as energy consumption (equivalent to the energy that would have been released if they had been used as fuel). For example, feedstock energy equivalent use totals over 1/2 of energy consumption in the chemical industry². Efforts are under way to reduce hydrocarbon use for feedstocks by implementing more efficient technology in using the feedstock and by switching to biomass based feedstock.

Energy losses in production and delivery to industrial users consume about 30 percent of primary energy destined for industrial delivered energy³. Another 30 percent of primary energy is lost within the industrial activities. This leaves around 40 percent of primary energy produced for industry being used to serve process needs for delivered heat and electricity.

The U.S. Department of Energy (DOE) compiles and reports information on industrial energy use. There are various ways to categorize and organize these data. For example, tabulations may report total primary energy use, total delivered energy use or delivered energy use for heat and power only. Those who consult DOE tabulations are cautioned to check the basis for the reported data.

17.4 Industry-Specific Consumption

Eight energy-intensive industries consumed around 64 percent of total delivered industrial energy in the U.S. in 1998⁴. The eight industries are bulk chemicals, petroleum refining, paper, food, steel, aluminum, cement, and glass. Manufacturing is the largest consumer of energy in the industrial sector by a wide margin.

Data on delivered energy consumption in industry appear in Table 17-1. These data illustrate the energy use distribution among various industries. These data are rather old, but they provide a unique snapshot that presents manufacturing and non-manufacturing energy use on a consistent basis. Appendix Q provides details on energy use in selected industries.

**Table 17-1. Delivered Energy Consumption
in Industry (1998)⁴**

Manufacturing	Consumption Quads
Food	1.03
Paper	2.73
Bulk Chemicals	6.70
Petroleum Refining	3.13
Glass	0.20
Cement	0.36
Steel	1.59
Aluminum	0.45
Metal-Based Durables	1.47
Others	2.90
Total Manufacturing	20.56
Non-Manufacturing	
Agriculture-Crops	0.71
Agriculture-Other	0.41
Coal Mining	0.09
Oil and Gas Extraction	1.51
Other Mining	0.31
Construction	1.78
Total Non-Manufacturing	4.81
Total for All Industry	25.37

The primary energy consumed to produce the delivered energy was about 35 Quads in 1998, indicating production, transmission, and distribution losses amounted to almost 30 percent of primary energy consumption.

17.5 Industrial Energy Consumption and the U.S. Economy

The U.S. economy is shifting toward importing finished products rather than producing those products domestically from either domestic or imported raw materials. The media often inform readers and viewers that this is because low cost foreign labor is causing industries to leave the U.S. Less noticed, but also important, are stringent U.S. environmental regulations and the influence of lower foreign energy cost on decisions by industries to leave the U.S.⁵ For example, natural gas (which we have seen to be essential for many industrial processes) has been much less expensive in the Middle East than the U.S. in recent years. (Natural gas cost in the Middle East was less than one-fourth of the U.S. cost in 2005.)

The impact of natural gas cost is especially strong in the chemical industry. Almost all new chemical plant construction is outside of the U.S. However, the increase in natural gas availability in the U.S. due to hydrofracturing of shale gas deposits may influence future decisions on locating chemical plants.

Energy-intensive industries also face the decision of whether to bring the raw materials to places where energy is cheap or to produce the energy where raw materials are cheap. For example, in the past, it was decided to bring bauxite (aluminum oxide ore) to aluminum plants located where electrical energy was cheap. Such trade-offs will require re-evaluation as energy costs rise.

Of course, world industrial energy consumption is experiencing changes in demand as well as supply. Increasing populations in developing countries are creating greater demand for industrial products. These changes will be felt worldwide as new markets develop and energy requirements increase.

17.6 Supply Side Opportunities for Reducing or Modifying Energy Consumption

Energy is wasted in all industries. Eliminating all energy losses is impossible, but significant reductions are possible. American industry has already increased its energy efficiency in recent years. One index of manufacturing energy efficiency is the energy intensity, defined as the number of BTUs of energy consumed per dollar value of product shipments. For example, the manufacturing energy intensity decreased from 8,900 in 2002 to 6,900 in 2006.⁶

The dominant drivers for improved efficiency in industry are reducing production costs and complying with regulations. The capital cost of these changes is incurred when industries expect adequate subsequent operating cost reductions or when required by regulations. The changes may involve replacement of old equipment with new equipment of the same type, replacement with more efficient versions of the same type of equipment, modification of existing equipment or switching to a new, different type of equipment.

Manufacturing, which uses about 80 percent of delivered industrial energy, loses over 30 percent of the delivered energy to the environment rather than using it productively.³ Most of the delivered energy used in manufacturing is used for steam generation or for direct-fired process heaters (see Figure 17-4). These applications account for about three-fourths of delivered energy use in industry. In many processes, a material is heated to accomplish a desired change in chemical or physical properties and then cooled for storage, delivery or subsequent processing. The energy used for heating is lost if the cooling involves heat transfer to the environment. Some of that energy can often be recovered and used to preheat new material entering the process. Energy losses can also be reduced by installing better insulation on pipes, vessels, steam traps, etc., that contain hot or cold materials. Heat recovery and improved insulation have the greatest potential for energy savings in industry, but the economic practicality depends on the relative cost of the energy used and the capital cost for the modifications.

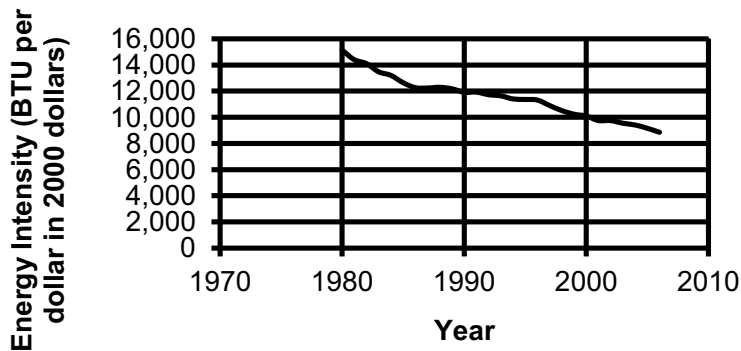

Figure 17-5. U.S. Energy Intensity

As availability, costs, and regulations related to energy from the various sources change, industry will adapt when possible by switching from one energy source to another. If petroleum and natural gas become too dear for use in some industrial process, then the most likely alternatives are coal and electricity. Coal use creates pollution and greenhouse gases, and its use will likely be restricted in the future. Transportation needs will probably account for all of the biofuel that can be produced. Electricity is the only energy supply that can grow without intolerable environmental effects or high costs due to supply shortages. The electricity for this transition could potentially be provided by wind, solar or nuclear power plants in order to reduce environmental effects that accompany use of coal fueled power plants. Also, producing electricity in plants that use natural gas is an option that causes smaller environmental effects than coal fueled plants, albeit while using a non-renewable resource.

Industrial plants with large electricity needs can often benefit by building and operating on-site cogeneration facilities. Cogeneration is the production of electricity and process heat in the same facility. Recall that thermal power plants necessarily waste about two-thirds of the thermal energy used to produce electricity. This wasted heat is usually dumped into a body of water or the atmosphere because there is no practical use for the heat at typical sites for power plants. Conversely, many industries need electricity and

process heat. Cogeneration is often economical, especially when the process temperatures needed are moderate.

17.7 Reinventing Industrial Processes

Many of the industrial processes that provide the products that sustain modern societies were developed when resources, especially energy resources, were plentiful and cheap, and there was little concern about environmental impacts. Now energy availability and cost are growing concerns, and simply moving industries to places that tolerate environmental damage is unsatisfactory. These factors are motivating an effort by researchers to reinvent industrial processes so they can produce the same products in a different way or can produce completely new products that can substitute for the old ones. Much work is under way, but much remains to be done before significant new energy-saving processes move from laboratory scale to industrial scale.

Industrial reinvention has occurred before, but the motivation was reduced cost and/or increased convenience, rather than energy conservation and environmental protection. For example, plastic bottles and aluminum cans have essentially replaced glass bottles for soft drinks. Plastic bags have largely replaced paper grocery bags. A revolution in the electronics industry occurred when transistors, then integrated circuits replaced vacuum tubes. The aircraft industry changed radically when jet engines replaced piston engines. These and many other changes show, with adequate motivation, that industry can reinvent the processes needed to provide desired commodities or services. Now, the challenge is to respond to a new set of motivations.

Steel production is a good example of recent industrial reinvention efforts. Traditional steelmaking starts in a blast furnace where iron ore (iron oxide) is mixed with coke (mostly carbon) at high temperature. The oxygen moves from the iron oxide to the carbon, forming carbon dioxide and iron. The iron takes in traces of carbon and other chemicals derived from the coke, and the resulting product is steel. So, traditional steelmaking results in heat

energy consumption and carbon dioxide release. One potential method for changing steelmaking is the electrolytic process. Laboratory results show electrolysis of iron ore dissolved in lithium carbonate at high temperature produces pure iron and oxygen⁷. Methods for the economical conversion of this pure iron into steel are yet to be developed, but this possible reinvention of steelmaking is the sort of thing that may revolutionize industrial processes.

There is no way to judge the future success of efforts to reinvent industrial processes. However, the potential payoff is so great that research in this area deserves major funding from government and industry.

17.8 What Can I Do?

The private citizen has no way to exercise direct control over energy use in industry. The most effective influence a private citizen can have is to develop an understanding of the energy used to make consumer products, and to choose products made by energy-efficient processes when possible. (See Section 20.2 for information on the energy needed to produce various products.)

References

1. *Annual Energy Review 2010 Table 2.1d Industrial Sector Energy Consumption Estimates, Selected Years 1949-2010 (Trillion Btu)* U.S. Energy Information Administration at http://www.eia.gov/totalenergy/data/annual/pdf/sec2_9.pdf.
2. *Annual Energy Outlook, 2011 U.S. Table 28* Energy Information Administration Report DOE/EIA-0383 (2011) at <http://www.eia.gov/forecasts/aeo/data.cfm?filter=industrial#industrial>.
3. "Energy Use, Losses and Opportunities Analysis: U.S. Manufacturing & Mining" Energetics, Inc. and E3M Inc., December 2004 at http://www1.eere.energy.gov/manufacturing/intensiveprocesses/pdfs/energy_use_loss_opportunities_analysis.pdf.

4. Unruh, B. *Delivered Energy Consumption Projections by Industry* Energy Information Administration Report at <http://www.eia.gov/oiaf/analysispaper/industry/consumption.html>.
5. *2006 Energy Consumption by Manufacturers—Data Tables, Table 6.1* Energy Information Administration at <http://www.eia.gov/emeu/mecs/mecs2006/2006tables.html>.
6. Halpern, R, Lopp, S., Beatty, S. et al. “Energy Policy and U.S. Industry Competitiveness” U.S. Department of Commerce, International Trade Administration, Office of Energy and Environmental Industries. Paper presented at the American Council for an Energy-Efficient Economy, July 2007 Summer Study on Industrial Energy Efficiency at <http://www.ita.doc.gov/td/energy/energy%20use%20by%20industry.pdf>.
7. “George Washington University Develops Carbon Dioxide-Free Method of Producing Iron” report of research by Licht, S. and Wang, B., George Washington University Press Release, August 24, 2010 at <http://www.gwu.edu/explore/mediaroom/newsreleases/georgewashingtonuniversityprofessordevelopscarbon dioxidefreemethodofproducingiron>.

Exercises

- 17-1. In difficult economic times, one would expect industrial activity to change in proportion to commercial activity. Use the Internet to determine whether this proportionality occurred in the recession that happened in the first decade of the twenty-first century. Discuss and interpret your findings.
- 17-2. It has been said industry must turn to greater use of electrical energy relative to other energy forms in the future. What do you think is the basis for this statement? Do you agree? Why?

18

**Transportation
Energy Use**

The Main Points

- Slightly less than one-fourth of the energy consumed in the U.S. is for transportation.
- Transportation relies on petroleum.
- Personal transportation accounts for most of U.S. petroleum consumption.
- Personal day trips average less than 30 miles (average travel to work is 12 miles).
- Trucks are much less energy efficient for hauling freight than trains or watercraft.
- Average freight hauls in the U.S. are over 600 miles.
- The U.S. has around one-fourth of the world's vehicles.
- Chinese vehicle production is growing rapidly, surpassing U.S. production in 2008.
- Only about 13 percent of fuel energy results in propulsion of automobiles with internal combustion engines in current use. New automobiles provide higher percentages (as high as 21 percent).
- About 75 percent of grid electricity results in vehicle propulsion in electric vehicles with rechargeable batteries.
- Batteries are much more efficient than fuel cells, but much work is needed to provide better batteries.

- **Adopting batteries or hydrogen fuel cells for vehicle propulsion would require increases in electrical generation and transmission systems.**
- **Adopting hydrogen fuel cells for vehicle propulsion would require a new hydrogen distribution infrastructure.**
- **Plug-in hybrids permit the use of battery energy for most of local travel while achieving greater range with an internal combustion engine that takes over when battery energy is exhausted.**

18.1 Introduction

Vehicles convert stored or transported energy into mechanical energy. The form of the stored energy is chemical for internal combustion engines and battery or fuel cell powered electric motors. Transported energy is grid electricity for electric trains, buses, and trolleys.

Vehicles need mechanical energy for four functions:

1. To increase speed (increase vehicle kinetic energy)
2. To climb hills (increase vehicle potential energy)
3. To overcome friction and air resistance
4. To operate accessories and auxiliaries and to idle

Most of the stored or transported energy is lost as heat. Heat is produced in the conversion of other energy forms into mechanical energy, and some of the produced mechanical energy is lost to friction and air resistance. Some of the mechanical energy is used by vehicle accessories and auxiliaries (pumps, fans, lights, etc.), thereby reducing the energy available for propulsion.

A vehicle moving at constant speed along a flat road does not convert any stored or transported energy into kinetic or potential energy. All of the energy is used to produce waste heat, overcome friction and wind resistance, and operate accessories.

The potential opportunities for improving energy utilization in transportation are as follows:

1. Increase the thermal efficiency of the engine (reduce waste heat)
2. Reduce energy losses within the vehicle (mainly, reduce friction)
3. Decrease the work needed to move the vehicle (reduce drag by streamlining, reduce vehicle weight and/or reduce rolling friction)
4. Recover energy from the waste stream (utilize some of the waste heat and recover energy lost in braking)

18.2 Transportation Energy Consumption

Transportation accounts for most of the U.S. consumption of petroleum, the energy commodity whose continued supply is most uncertain.

Transportation energy consumption in the U.S. in 2009 was about 27 Quads¹, with about 96 percent of this energy derived from petroleum¹. The largest components of transportation energy use are for passenger and freight transport. Table 18-1 shows statistics for 2008¹.

Table 18-1. Transportation Energy Use

Mode of Travel	Percentage of Total Transportation Energy
Light vehicles	61.3
Buses	0.7
Trucks	18.7
Aircraft	8.9
Boats, barges, and ships	4.6
Pipelines	3.4
Rail	2.4

Clearly, personal travel is the dominant user of transportation energy. It accounts for essentially all of the energy used in light vehicles, buses, and aircraft and a small portion of the energy used by trains. Trucks, watercraft, and trains carry almost all freight except for hydrocarbons carried in pipelines.

Statistics for consumption by U.S. road vehicles are shown in Table 18-2.

Table 18-2. U.S. Petroleum Consumption for Road Vehicles (2008)¹

	Petroleum Consumed (Billion Barrels)	Percentage of Road Vehicle Consumption
CARS	1.70	41.8
VANS & LIGHT TRUCKS	1.46	35.8
HEAVY TRUCKS	0.87	21.7
BUSES	0.04	0.8
TOTAL VEHICLES	4.07	100
(Note: Motorcycles are excluded. Sport utility vehicles are included in the light truck category.)		

Freight transport is usually measured in ton-miles: the product of the tons of freight transported multiplied by the number of miles the freight was moved. Over 4.5 trillion ton-miles of freight are hauled in the U.S. every year². The energy efficiency of freight transport is measured by the energy required to carry a ton of freight a distance of one mile and is called the energy intensity. Statistics are shown in Table 18-3:

Table 18-3. Freight Energy Intensities¹

Mode of Inter-city Freight Transport	Energy Intensity (BTU per ton-mile)
Trucks	3,037
Watercraft	457
Trains	362

Hauling freight on trains or watercraft is clearly much more energy efficient than hauling on trucks. Trains are about 8.4 times as energy efficient as trucks for hauling. This may have importance in the future when improving energy efficiency is likely to be crucial.

Inter-city freight transport in the U.S. has evolved into a major component of fuel consumption. In 2007, average freight hauls were 619 miles for all modes of freight transport³, showing the American economy currently relies on long distance hauling of goods. Future fuel economy efforts may focus on reducing freight transport distances by greater reliance on goods produced near their place of use.

The transport of food has received special attention, and the term, food miles, is used to quantify transport distances for food. Various estimates exist for average food miles in the U.S., but they range from 1,300 to 2,000 miles⁴. There are advocates of more reliance on locally produced foods, and there are those who say that hauling is justified for food produced where production conditions are optimum. This debate is likely to become more important in the future.

The statistics for average day trip distances for various purposes are shown in Table 18-4. Long trips are not included.

Table 18-4. Average Day Trip Distances in 2010⁵

Purpose	Distance (miles)
Vacation	37
Work-related business	29
Visit friends/relatives	14
To/from work	12
Medical/dental	10
Shopping	7
School/church	7

These data are important in defining range and energy storage requirements for personal vehicles.

In 2008, the average annual petroleum consumption for U.S. highway transportation was about 16 barrels per vehicle¹. This average consumption rate applies for the specific mix of vehicle types and driving practices in the U.S. The total petroleum consumed to fuel U.S. transportation in 2008 was 4.9 billion barrels¹. Road vehicles used about 4.1 billion barrels, 85 percent of all petroleum used for transportation¹. The remainder was used by trains, aircraft, watercraft, etc. Road vehicles used about 61 percent of all petroleum used in the U.S.¹

World petroleum consumption was about 29.3 billion barrels in 2008¹. The U.S. used around 17 percent of world petroleum production to satisfy its transportation needs in 2008.

A major concern about petroleum is whether consumption can be aligned with future availability of adequate and affordable petroleum supplies. Chapter 4 showed that petroleum availability is a looming problem for the U.S. and the world.

Of course, the other major concern about petroleum is the environmental effects related to its use.

18.3 Vehicle Statistics

World and U.S. annual vehicle production appear in Figure 18-1. The U.S. produced only 10 percent of world vehicles in 2010⁶. For comparison, the U.S. produced 22 per cent of world vehicles in 2000⁶. The economic recession that started in 2008 resulted in a large decrease in vehicle production in the U.S. and in most of the world. (China is the exception.) U.S. vehicle production has since increased, but it remains to be seen whether vehicle production will return to the earlier pattern or will undergo a lasting change.

U.S. vehicle sales, production, and imports appear in Figure 18-2. The large share of imports is apparent.

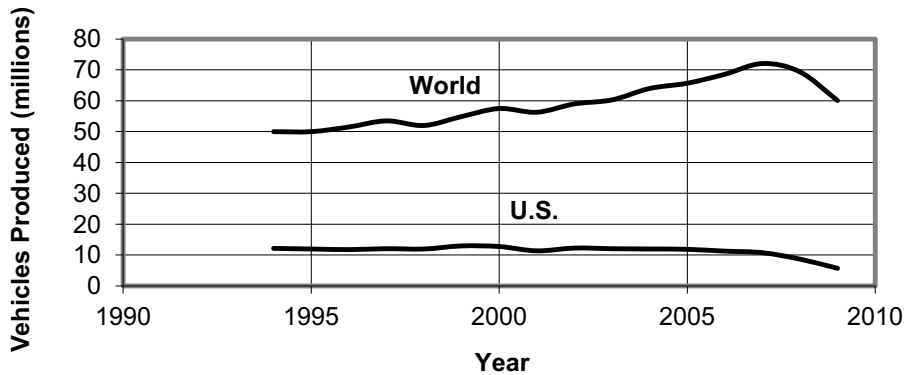

Figure 18-1. U.S. and World Vehicle Production

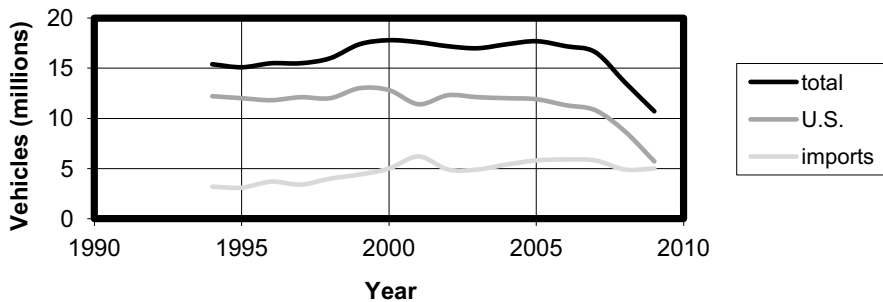

Figure 18-2. U.S. Vehicle Sales, Production and Imports

Energy consumption for transportation appears in Figure 18-3. The downturn in 2008 illustrates the impact of the recession on transportation energy use.

In 2008, the number of world vehicle registrations was around 942¹ million vehicles, and the world vehicle production rate was 60 million vehicles. The U.S. vehicle registrations totaled around 250 million,¹ and U.S. vehicle purchases totaled around 13.6 million¹.

Figure 18-4 shows vehicle production in the U.S. and China. Chinese production passed U.S. production in 2008. The U.S. still has the largest share

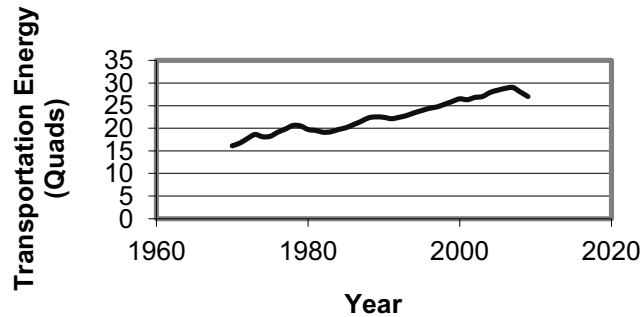

Figure 18-3. U.S. Transportation Energy

of world vehicles in use (around one in four in 2008), but China is gaining rapidly (China's production is growing at rates of as great as 40 percent per year⁶).

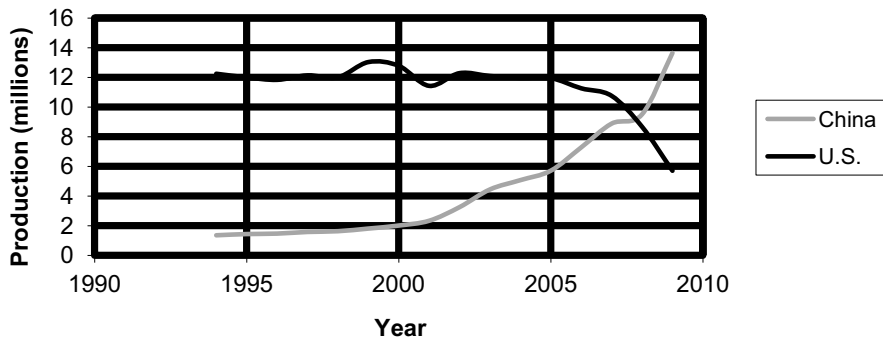

Figure 18-4. U.S. and Chinese Vehicle Production

It should be noted that vehicle registrations outside of the U.S. were about three times the U.S. registrations in 2009. World petroleum use for transportation and concomitant resource depletion and environmental effects are thus much more dependent on non-U.S. actions than on those by the U.S.

The impact of any improvements in fuel economy of new vehicles in the future will occur over a period of years as older vehicles are replaced by

newer, more efficient models. The average useful life of vehicles is slightly over 10 years¹.

18.4 Vehicles with Internal Combustion Engines

18.4.1 Gasoline and Diesel Power

Gasoline is the dominant fuel for automobiles in the U.S. Gasoline consumption in the United States in 2010 was 378 million gallons per day⁷. Efforts to improve mileage and reduce polluting and climate-altering emissions have been under way for many years. There has been progress, but the incentive to reduce petroleum consumption is now increasing among manufacturers, citizens, and governments due to concerns about availability and about environmental effects related to fossil fuel use.

In a typical automobile, energy utilization is as follows⁸:

- 62.4% waste heat (in exhaust gases, to the air through a radiator, and by direct transfer from hot surfaces to the air)
- 17.2% standby idling
- 2.2% accessories
- 5.6% drivetrain losses
- 12.6% energy to wheels

Figure 18-5 shows the losses schematically. The small fraction of consumed energy that gets to the wheels is striking. It should be noted the same reference later reports higher percentages of energy delivery to the wheels (as high as 21 percent). Increasing emphasis on improved energy utilization in new vehicles drives such increases.

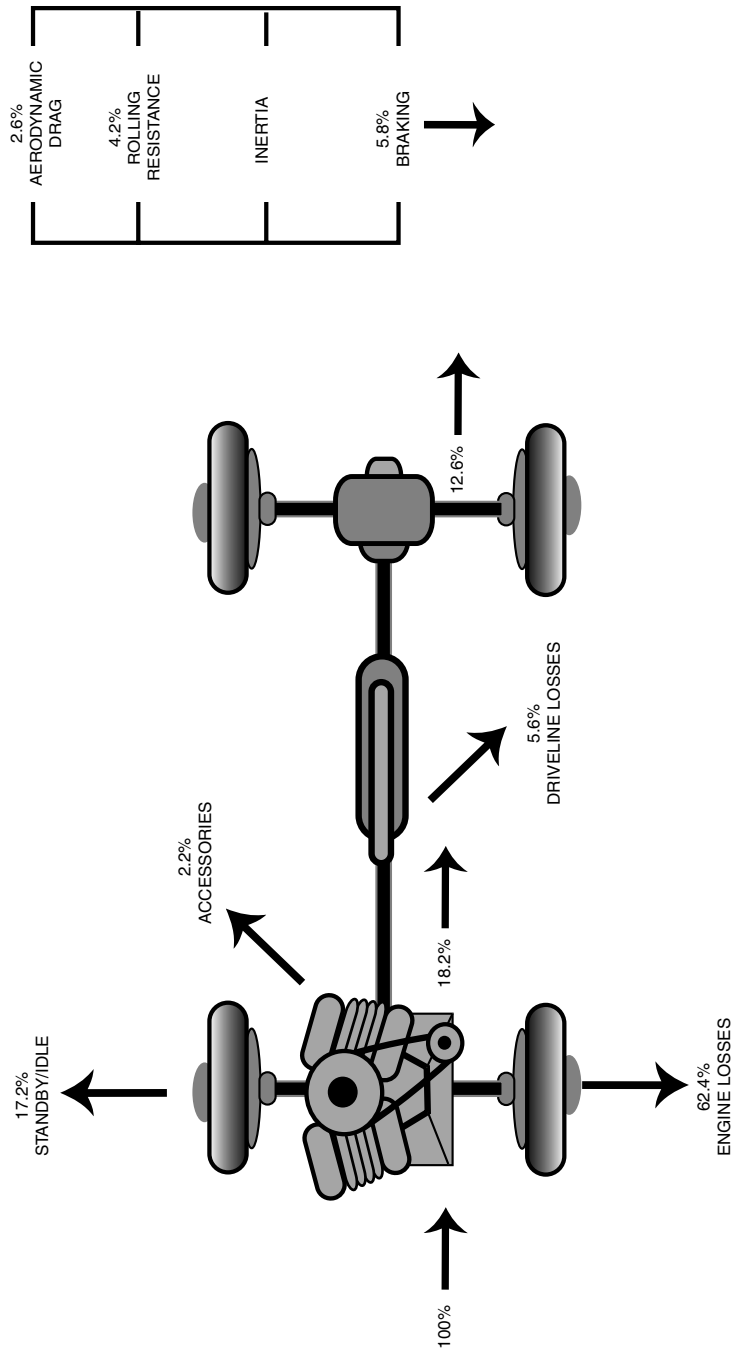

Figure 18-5. Automobile Energy Uses

The exhaust from a gasoline-powered vehicle consists mostly of unburned fuel, carbon dioxide, oxides of nitrogen, and water.

Diesel engines are also widely used in transportation. The main difference between gasoline engines and diesel engines is the way in which the injected fuel is ignited. Gasoline engines use a spark plug to ignite the fuel in an air-fuel mixture when the piston travels to the top of the cylinder. Diesel engines use compression of the air in the cylinder, thereby causing it to heat to a high temperature. Fuel is injected into the hot, compressed air whose temperature is high enough to cause ignition.

Diesel engines are much more common in private automobiles in Europe than in the U.S. They are widely used worldwide in large engine applications such as heavy trucks, trains, and boats. Diesel engines are also used to provide electricity, especially in backup systems that start operation when grid electricity is interrupted. Diesel engines operate at higher thermal efficiencies (more miles per gallon for vehicles), can use a variety of fuels (including biodiesel), and generally last longer than gasoline engines, but they are heavier, cost more, and the fuel currently used costs more

18.4.2 Gas Turbine Power

Gas turbines employ internal combustion of fuel to create gas flow. A typical gas turbine has a compressor at the air entrance. The compressor delivers compressed air to a combustion chamber, where fuel is injected and ignited. The hot combustion gas exits through turbine blades, which are mounted on the same shaft as the compressor and which deliver power to the compressor.

Gas turbines may be designed to maximize the thrust provided by the exhaust gases or to maximize the capture of mechanical energy from the rotating shaft. Jet engines used to propel airplanes use designs that maximize thrust. Applications that involve the capture of mechanical energy use gears to reduce rotational speed and transmit power. If the mechanical energy is used to drive an aircraft propeller, the system is called a turboprop.

If the mechanical energy is used to drive helicopter rotors or some other machine, the system is called a turboshaft.

Gas turbines are widely used to drive a generator to produce electricity. The plants can be built quickly, they produce less pollution and carbon dioxide than coal-fueled plants with equal capacity, and they are well-suited for load-following operation.

18.5 Electric Vehicles

Electric power for transportation involves direct use of grid electricity (in trolleys, buses, and trains) or stored chemical energy from batteries or fuel cells. Vehicles that use batteries or fuel cells come in three varieties: all electric, hybrid, and plug-in hybrid.

18.5.1 Electric Propulsion vs. Internal Combustion Engine Propulsion

Internal combustion engines and electric motors are capable of vehicle propulsion, and each possesses relative advantages and disadvantages.

Gasoline and Diesel internal combustion engines use fuel with high specific energy, thereby providing good range with modest weight and volume requirements for on-board fuel storage. Refueling is quick and is served by a large network of filling stations. On the other hand, these engines are complex mechanical systems whose pistons and connections experience many repeated accelerations and decelerations, which require careful design and high-strength materials to achieve long life. They require lubrication and cooling systems. They require complex and heavy drivetrain systems. They achieve full torque only when running at full speed.

Electric motors used for vehicle propulsion are simpler, quieter, smaller, and lighter than gasoline or Diesel engines of the same output. They require no cooling system and little or no lubrication. Vehicles with electric propulsion can eliminate complex and heavy drivetrain equipment (energy may be

carried to the motors through wires). Electric motors generate high torque at all speeds.

On the other hand, electric propulsion requires either physical contact with electric lines or on-board batteries or fuel cells that use stored fuel such as hydrogen. Batteries have much lower specific energy than gasoline or Diesel fuel, thereby imposing weight and volume penalties for achieving long range capability. Rechargeable batteries take hours to recharge, requiring attention to schedules for driving and recharging. Hydrogen fuel cells require on-board storage of high pressure gas or equipment to generate hydrogen from on-board materials. Storage of sufficient hydrogen for acceptable range requires strong, heavy containers capable of withstanding high pressure.

Batteries require electricity for recharging, and hydrogen for fuel cells requires electricity for production by hydrolysis. The electricity could be obtained from the grid, or from local production (such as photovoltaic systems), but the grid will be called upon for the bulk of the required electricity. Large increases in battery power and/or fuel cell power for transportation would require large increases in grid electricity production either from either renewable or nonrenewable generating systems. Hydrogen could be produced at a power plant and delivered to users, but delivering electricity to users for battery recharging or local hydrogen production would require a major expansion in the electricity transmission and distribution system.

Vehicles that obtain their energy from external sources of electricity generate no harmful emissions at the site of energy use. Emissions occur at fossil fuel power plants, or not at all in the case of renewable or nuclear electricity.

An all-electric or hybrid vehicle may have a single drive motor or separate motors mounted in the wheels. The use of small, in-wheel motors eliminates the need for mechanical linkages since the energy is carried through wires to the site where energy is transferred to the wheels.

Although each type of propulsion has significant advantages and disadvantages, both are viable choices for transportation applications. The availability of liquid fuels, the environmental effects, and the costs associated with each type of propulsion system will dominate future choices for propulsion systems.

18.5.2 Grid Power for Vehicle Energy

To be able to rely entirely on direct use of grid electricity for propulsion, vehicles must travel regular routes. Trains, trolleys, and city buses generally follow regular routes. Considerations that might justify the cost of installing electric lines are cost relative to other types of propulsion and elimination of local air pollution and noise.

18.5.3 Dual Power Systems for Vehicles

Vehicles with two separate power systems are called hybrid vehicles. Hybrid vehicles are categorized by whether the electrical power is generated entirely on-board by an engine/generator and regenerative braking and deceleration, or at least partially by connection to an external source of electricity for battery charging. A vehicle that uses only electricity generated on-board is called a hybrid electric vehicle (HEV). A vehicle that derives some of its electrical energy from an external source is called a plug-in hybrid electric vehicle (PHEV).

Hybrid vehicles (HEVs and PHEVs) exist or are being developed in two different configurations. The distinction is whether the energy from the two sources is delivered in a series arrangement or a parallel arrangement.

In a series configuration, the internal combustion engine drives a generator that supplies energy to a battery and/or drive motor. It has no direct connection between the internal combustion engine and the wheels (see Figure 18-6).

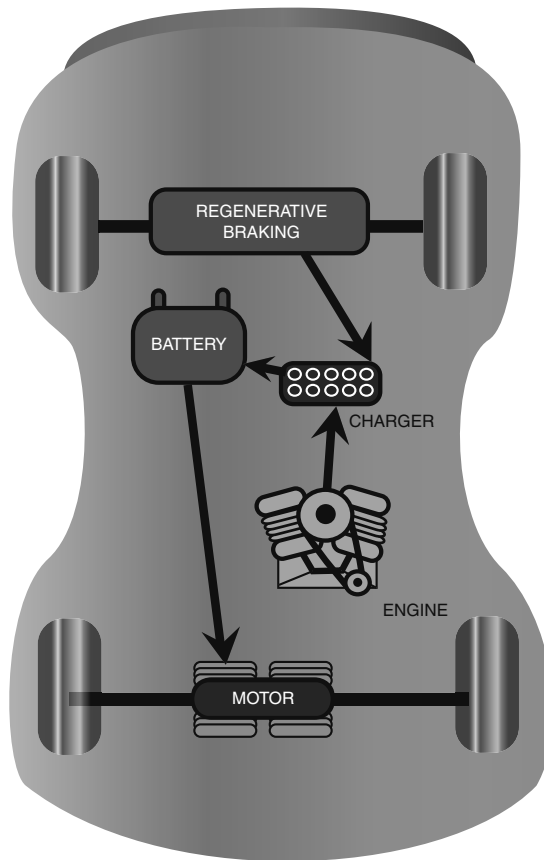

Figure 18-6. A Series Hybrid Vehicle

In a parallel configuration, the internal combustion engine and a motor powered by a battery or fuel cell both supply energy to a transmission that transmits energy to the drive wheels (see Figure 18-7).

Battery hybrid vehicles (in both configurations) that do not use external electrical energy (HEVs) achieve improved fuel economy in five main ways:

- In providing propulsion energy and battery charging, the internal combustion engine can be run closer to optimum operating conditions than would otherwise be possible.

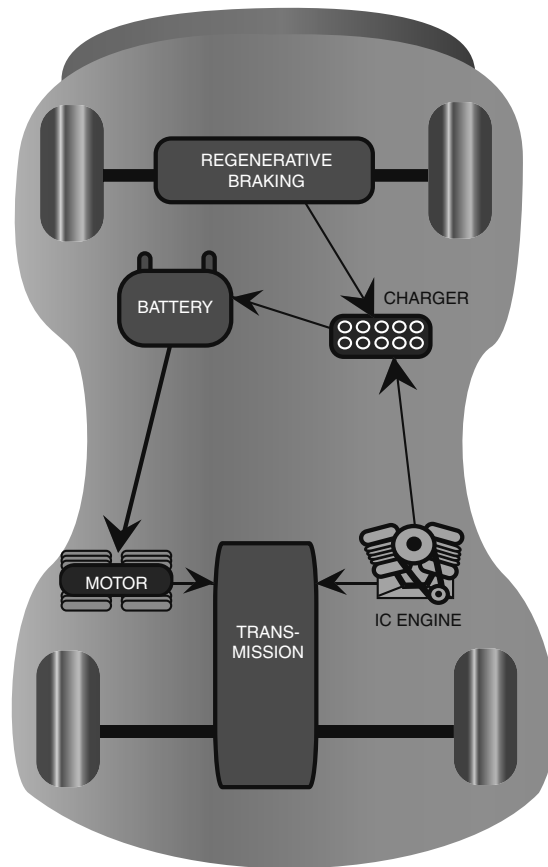

Figure 18-7. A Parallel Hybrid Vehicle

- The internal combustion engine can be less powerful than would otherwise be needed because the battery and motor can combine to provide additional propulsive power when it is needed.
- The engine can be turned off when the vehicle is idling. Initial movement after a standstill is provided by the battery and the electric motor.
- Battery energy is used during initial acceleration to cruising speed instead of the internal combustion engine, whose operation is inefficient during this type of operation.

- Regenerative braking and deceleration are used. Transferring energy from the wheels to the generator that charges the battery slows the vehicle.

Plug-in hybrid vehicles (PHEVs) provide the same features outlined above and, in addition, they have the ability to charge their batteries using electricity from the grid or from some local source such as a photovoltaic system.

18.5.4 Batteries for Vehicle Energy

Rechargeable batteries receive their energy by converting electrical energy into chemical energy during charging. The chemical energy is converted back into electrical energy when electricity is needed for the ultimate conversion into mechanical energy with a motor. The energy conversion processes in battery use result in energy losses, but they are small. The efficiency for each step is around 90 percent or greater. Consequently, the overall efficiency of electrical to chemical to electrical to mechanical processes is over 75 percent.

Battery performance is important in electric and hybrid vehicles. The number of options for materials and configurations in a battery is large. The common lead-acid battery that has been used in vehicles for decades lacks the performance needed for vehicle propulsion. Of the many battery types available, the nickel metal hydride and lithium ion batteries are the current favorite candidates for vehicle propulsion applications.

Range for vehicles using battery power depends on the energy storage capacity of the battery. Vehicle power depends on the rate at which the battery can deliver energy. Other important battery characteristics include its weight, its volume, its recharge characteristics, its tendency to discharge when not in use, its safety, its useful life (number of charge/discharge cycles), its waste disposal and/or recycle characteristics, and its cost.

A battery's energy storage capacity is usually designated by its specific energy (watt-hours per kilogram) and its power by its specific power (watts per kilogram). Battery-specific energy varies with battery type, but the values

are all currently somewhat less than 100 watt-hours per kilogram. For comparison, gasoline combustion releases about 12,000 watt-hours per kilogram.

The specific energy, and, therefore, vehicle range, is the main issue with batteries for vehicle propulsion. A major research and development activity to improve battery capability is under way. The main player in the U.S. is the Advanced Battery Consortium (the ABC)⁹. The ABC is funded by U.S. automakers and collaborates with the Department of Energy in funding battery research. The ABC has established goals for battery performance. The specific energy goals are 150 watt-hours per kilogram (mid-term) and 400 watt-hours per kilogram (long-term).

Electric vehicles and hybrid vehicles have quite different battery requirements. Electric vehicles rely on battery energy for all travel. Consequently, total battery energy must be great enough to satisfy energy needs for anticipated trips. Electric vehicles are best suited for local travel. Hybrid vehicles have internal combustion engines that can take over when the remaining battery energy is low. The batteries are charged by the on-board engine/generator and/or external electrical power (in the case of plug-in hybrids). Batteries in hybrid vehicles have a lower total energy requirement than batteries in electric vehicles. The desirable range for battery-powered operation of plug-in hybrid vehicles is under debate, but a requirement of 40 miles is often mentioned. A 40-mile battery-powered range would allow the vehicle to handle most of local travel with electricity (see Table 18-4).

Using electric motors for propulsion makes regenerative braking feasible. The motor can act as a generator, thereby transferring energy to the battery while causing the vehicle to decelerate. This avoidance of energy loss to braking is very beneficial in stop-and-go urban travel.

Work is under way to improve the practicality of all-electric battery-powered vehicles. The main issue is overcoming range limitations. Batteries with higher specific energies and faster recharge times are under development. Battery exchange is one way to avoid the limitation imposed by the slow

rate of battery charging. For example, a system in which a network of service stations that provides rapid battery exchange is being built in Israel.

One approach for reducing the initial cost of a battery-powered vehicle is to sell the vehicle without a battery, and rent batteries to customers who pay for the energy used when they exchange depleted batteries for fully-charged batteries.

The three types of vehicles that employ battery energy (all electric, HEV, and PHEV) each impose somewhat different performance requirements on the battery. The issues are the “depth of discharge” and the number of charge/discharge cycles used for each type. An all-electric vehicle battery is usually recharged once a day, and the charge is drained continuously until travel is completed. This is called the depletion mode of battery operation. The battery in an HEV is kept within a small range around some intermediate level of charge. The on-board internal combustion engine drives a generator that charges the battery. This is called the charge-sustaining mode. The PHEV typically begins travel with a full battery charge and operates in the depletion mode until a predetermined level of discharge, then switches to the charge-sustaining mode with energy provided by the on-board engine and regenerative braking and deceleration.

The number and depth of discharges influence battery life. PHEV systems impose the greatest impact on battery life. Consequently, PHEV batteries generally have more energy storage capacity than the minimum required in order to minimize deep discharges and associated life reductions.

A typical mid-size car requires 200 to 400 watt-hours per mile of travel. With a design requirement of having excess capacity of 1.5 to 2 times the minimum energy requirement often being applied to increase battery life, the required stored energy in the battery increases to 300 to 800 watt-hours per mile. For example, to travel 40 miles on battery energy, a battery with a specific energy of 100 watts per kilogram would have a mass of 120 to 320 kilograms (a weight of 260 to 700 pounds).

18.5.5 Fuel Cells for Vehicle Energy

Fuel cells come in two main varieties, those that use hydrogen from an external source (called hydrogen fuel cells) and those that produce hydrogen *in situ* from hydrocarbon or alcohol fuel. In addition, it is possible (but uncommon) to use methanol directly without producing hydrogen (in a system called a direct methanol fuel cell).

Hydrogen fuel cell energy generation is based on processes with lower energy conversion efficiencies than those associated with battery use. Hydrogen can be produced from fossil fuels or biomass, but the most likely technology for widespread hydrogen production is electrolysis of water. The energy budget for hydrogen fuel cell use includes energy losses in electrolysis, gas compression and/or liquefaction, transmission or delivery, transfer to the vehicle, fuel cell operation, and electric motor operation. The overall efficiency of converting electricity from an external source into useful mechanical energy with a system powered by a fuel cell is about 30 percent^{10,11,12}. Consequently, on an energy efficiency basis, fuel cell powered vehicles using currently available technology require about 2-1/2 times as much energy from a source of electricity as a battery powered vehicle. Work is underway to improve the efficiency of hydrogen production, storage, transport, transfer, and usage, but fuel cells have a long way to go to be competitive with batteries on an efficiency basis.

In fuel cells that use hydrocarbons or alcohols as fuel, hydrogen is produced by steam reforming (see Section 12.3.1) except for the less common direct methanol fuel cell. These systems overcome the storage problems associated with hydrogen fuel cells, but they must operate at high temperature, and they are expensive. Currently, they are better suited for stationary application than for use in vehicles, but researchers are working on designs that will enable practical applications in vehicles. The goal is to develop viable systems that permit use of hydrocarbons and alcohols with higher efficiencies than using them in internal combustion engines and, therefore, less carbon dioxide release per unit of useful energy.

18.6 Hybrid Vehicle Status

Hybrid vehicles are not new. Diesel-electric trains have used hybrid power for a long time. These popular systems use a Diesel engine to drive a generator that delivers electric power to drive motors. This arrangement avoids the need for a transmission and provides strong torque at all speeds.

Hybrid automobiles from several automakers have entered the market in recent years. An early HEV, the Toyota Prius, has enjoyed rapid commercial success. Other automakers are rapidly developing and offering their own hybrid vehicles (both HEV and PHEV versions).

Plug-in hybrid vehicles appear to be a viable way to greatly reduce or eliminate dependence on fossil fuel for transportation. These vehicles permit maximization of electrical energy use for transportation without limiting the vehicle's range. Hybrid vehicles also facilitate a smooth transition from transportation energy produced with fossil fuels to renewable and nuclear electricity. The liquid fuel can be derived from petroleum, from biomass or from a mixture of the two. Electricity for charging batteries can be obtained from fossil fuel power plants or from renewable or nuclear sources.

18.7 Gas Power

Natural gas can be stored under pressure and used in internal combustion engines. Current applications of natural gas in the U.S. are mostly for buses. Propane is also used to power cars and material-handling vehicles such as forklifts. Using natural gas or propane results in fewer emissions of pollutants and carbon dioxide than using gasoline or diesel fuel.

18.8 Future Transportation Energy

The future use of petroleum for transportation must eventually decrease because of consumption curtailment for environmental protection purposes or production capacity limitations. The steps that must therefore be

taken are increasing vehicle fuel efficiency, switching to alternative fuels and/or reducing the total miles traveled by the world's fleet of vehicles.

Improving fuel efficiency is an effective way to curb fuel use, but it only affects those vehicles produced after efficiency improvements were introduced. The remainder of the fleet continues to operate at the older, lower efficiency. Full fuel savings from the introduction of more efficient vehicles will occur only after most of the older, less efficient vehicles are retired.

Alternative fuels can replace petroleum for transportation, but producing sufficient quantities of biofuels is a huge undertaking that would strain land use and the environment (see Section 7.2). Converting to the use of electric energy for battery power or hydrogen fuel cell power will require a huge increase in electricity production and in the electrical transmission and distribution system.

Reducing the total miles traveled per year by the world's vehicles is difficult to imagine, given the expected population growth and the expected development in currently under-developed countries. Some countries, notably the U.S., that have opportunities for changes that reduce consumption while causing minimal lifestyle effects, can reduce total miles traveled per year if the citizens and government so choose. Increasing vehicle use in developing countries will only increase total miles travelled regardless of any frugality practiced by citizens of these countries.

It is foolish to even guess at the way future transportation energy use will evolve. The only sure bets are that current use patterns must change, and that no single change can do it all.

References

1. Davis, S. C., Diegel, S.W. and Boundy, R.G. *Transportation Energy Data Books, Edition 29* June 2010 Oak Ridge National Laboratory Report at http://www.cta.ornl.gov/cta/One_Pagers/Databook-Ed29.pdf.

2. “U.S. Freight Ton-Miles by Mode” Bureau of Transportation Statistics report at http://www.bts.gov/publications/special_reports_and_issue_briefs/special_report/2007_07_27/html/table_01.html.
3. “2007 Commodity Flow Survey” Bureau of Transportation Statistics and U.S. Census Bureau report at <http://www.census.gov/prod/2010pubs/ec07tcf-us.pdf>.
4. Bruch, M.L. “Marketing and the Food Miles Concept” University of Tennessee Center for Profitable Agriculture report CPA Info #80, at <http://cpa.utk.edu/pdffiles/cpa80.pdf>.
5. “Transportation Statistics Annual Report 2003” Bureau of Transportation Statistics report at http://www.bts.gov/publications/transportation_statistics_annual_report/2003/html/appendix_b/table_027.html.
6. “Production Statistics” Organization Internationale des Constructeurs d’Automobiles at <http://oica.net/category/production-statistics>.
7. “Petroleum Statistics” U.S. Energy Information report at http://www.eia.gov/energyexplained/index.cfm?page=oil_home#tab2.
8. “Advanced Technologies & Energy Efficiency” U.S. Government at <http://www.fueleconomy.gov/feg/atv.shtml>.
9. Snyder, K. “Overview and Progress of U.S. Advanced Battery Consortium (USABC) Activity” at http://www1.eere.energy.gov/vehiclesandfuels/pdfs/merit_review_2011/electrochemical_storage/es097_snyder_2011_o.pdf.
10. Eaves, S. and Eaves, J. “A Cost Comparison of Fuel-Cell and Battery Electric Vehicles” *Journal of Power Sources* Volume 130, Issues1-2, May 2004, pp 208-212.
11. A series of papers by Ulf Bossel accessed at the European Fuel Cell Forum web site <http://www.efcf.com/reports/>.
12. Brooks, A. N. “Perspectives on Fuel Cell and Battery Electric Vehicles” at <http://www.acpropulsion.com>.

Exercises

- 18-1. Estimate the energy saving (in BTUs and in gallons of Diesel fuel) if 10 percent of freight hauling switched from trucks to trains.
- 18-2. The engine, transmission, and cooling systems used in conventional automobiles are not needed in electric automobiles. These

components typically have a weight of around 900 pounds. If a battery with an energy density of 100 watt-hours per kilogram with weight equal to the weight of 900 pounds, estimate the range of the vehicle on battery power for a mid-size car.

- 18-3. The Chevrolet Volt (a plug-in hybrid) and the Nissan Leaf (an all-electric car) entered the market in 2011. Investigate the approval rating of these automobiles following their introduction and discuss your findings.
- 18-4. If the goal of 400 watt-hours per kilogram for battery-specific energy is achieved, what range is possible with a mid-sized car having a 300-kilogram battery?
- 18-5. Electrically powered vehicles achieve greater energy savings over vehicles with internal combustion engines in urban travel than they do in highway travel. Why?
- 18-6. America now has around 157,000 miles of high voltage transmission lines to deliver around 14 Quads of electricity. If electricity for charging automobile batteries in the future required a 10 percent increase in electricity production, the increase in transmission lines would be less than 10 percent. Why?
- 18-7. Using electric power for vehicles permits the reduction or elimination of energy consumption now incurred by internal combustion engines during idling. Estimate the energy savings if automobile idling in the U.S. was totally eliminated.
- 18-8. Estimate the percentage change in annual carbon dioxide release in the U.S. if half of the energy used for transportation came from grid electricity. Assume that 80 percent of electric energy would come from coal-fueled plants and 20 percent from energy plants with no carbon dioxide emissions.

- 18-9. A compact car has 24 square feet of solar panels on the roof. They convert solar energy into electricity with an efficiency of 20 percent. Estimate the distance the car can travel on solar energy on a day when the radiation absorbed on a horizontal surface is 2,000 BTU/sq ft. day.
- 18-10. Assume that electricity costs 11 cents per kilowatt-hour. Estimate the cost required for gasoline (\$ per gallon) to cause the operating fuel cost (\$ per mile for fuel) to be equal for a gasoline-powered car and a battery-powered car with a rechargeable battery.

19

Energy and Climate Change

The Main Points

- A balance between solar radiation absorption and radiation emitted by the earth determines the average earth temperature.
- Solar radiation and radiation emitted from the earth occur at different wavelengths.
- Atmospheric gases preferentially absorb radiation at certain wavelengths.
- Water vapor is the major absorber of earth radiation emissions.
- Carbon dioxide is the major earth radiation absorber that is released as a result of human activity.
- Fossil fuel combustion and deforestation cause increases in atmospheric carbon dioxide.
- There is no doubt that atmospheric gases affect the earth's temperature, but predicting the temperature rise for a specific change in atmospheric gas concentration is difficult and uncertain.
- Data show that the concentration of atmospheric carbon dioxide is increasing.
- Data show that the average earth temperature began increasing after the Industrial Revolution.
- The scientific consensus is anthropogenic gases in the atmosphere are causing global warming.

19.1 Introduction

Many processes for energy production, especially fossil fuel combustion, result in the release of gases into the atmosphere. Some of these gases are strong absorbers of radiation emitted from the earth. The greenhouse effect is the heating of the atmosphere by trapping radiated heat energy from the earth.

Understanding the science of climate change is essential in assessing the impact of energy-related activities. The science is unfamiliar to many, but rests on firmly validated physics. Appendix J provides a short summary of the underlying physics of radiation production and absorption. A more descriptive explanation appears in the following sections.

19.2 Physics of the Greenhouse Effect

All substances whose temperatures are above absolute zero emit electromagnetic radiation. Figures 19-1 and 19-2 show the emission spectra for the sun (average surface temperature = 5800 kelvins) and for the earth (average surface temperature = 288 kelvins or 15°C or 59°F). The sun's emission spectrum peaks at a wavelength of 0.5 microns, and the region with significant amplitude lies mostly between 0.2 and 1.5 microns. (A micron is a unit of length equal to one millionth of a meter.) The earth's emission spectrum peaks at a wavelength of 10.1 microns and the region with significant amplitude lies mostly between 4 and 30 microns. The wavelengths at which significant emissions from the sun and from the earth occur are essentially distinct and non-overlapping.

Photons can be absorbed, reflected, or transmitted in interactions with matter. The relative probabilities of these occurrences depend on the target material involved and the wavelength of the photon.

The exchange of energy between two emitting and absorbing bodies is a crucial concept in greenhouse effect discussions. If a body absorbs radiation

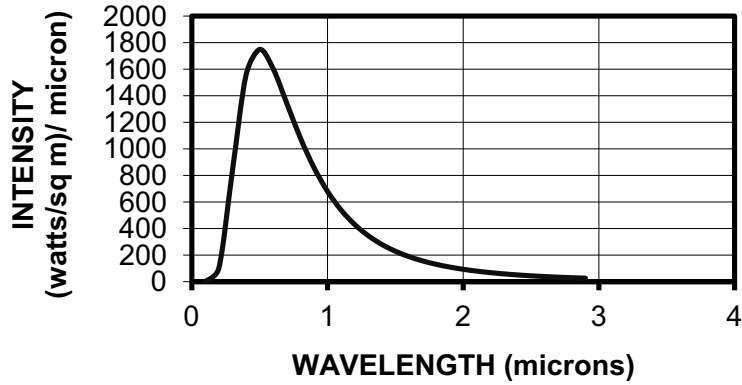

Figure 19-1. The Solar Spectrum

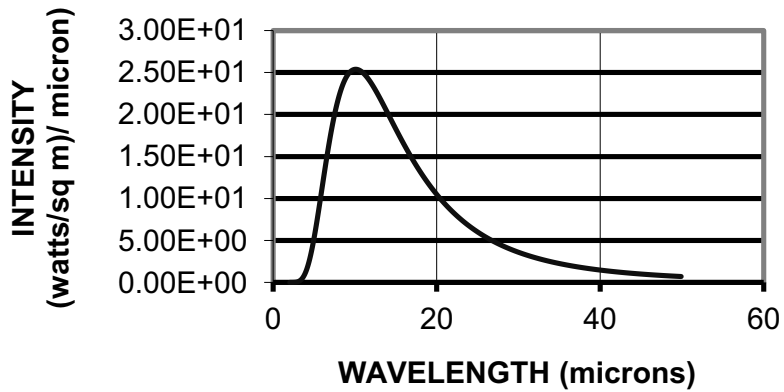

Figure 19-2. Earth's Radiation Spectrum

from another body, its temperature increases until its radiated energy equals the absorbed energy. Such is the case for the earth's temperature.

19.3 The Greenhouse Gases

The atmospheric gases with major photon absorption probabilities in the **sun's** emission spectrum are water, molecular oxygen, and ozone. The atmospheric gases with major photon absorption in the **earth's** emission spectrum are water, carbon dioxide, methane, nitrous oxide, ozone, and certain compounds of carbon and halogens (such as Freon). Water vapor is by far the largest absorber of radiation emitted from the earth. Water vapor is responsible for 90 to 95 percent of the atmospheric absorption of earth radiation emissions.

Because of the atmospheric absorption of earth emissions, some of the photons emitted from the earth do not escape into outer space. The earth's temperature must increase to achieve the energy transfer to outer space needed to balance the energy from incoming radiation.

The earth's temperature is higher than it would be if there were no greenhouse gases in the atmosphere. The increase in the earth's average temperature above the temperature that would occur if there were no greenhouse gases is estimated to be around 33°C (59°F). This warming is essential for life on earth. The concern is changes in the greenhouse effect due to human activities will further increase the earth's temperature and make it less suitable for sustaining life.

The greenhouse gases in the atmosphere include those that occur naturally and those that are due to human activities. Water vapor occurs because of evaporation (mostly from the oceans), and its atmospheric concentration is independent of human activities unless those activities cause changes in the rate of evaporation. Concentrations of the other important greenhouse gases in the atmosphere are the result of natural and manmade sources.

Carbon dioxide is the major contributor to anthropogenic global warming. The concentration of carbon dioxide in the atmosphere depends on the rate at which it is removed from the atmosphere by carbon sinks as well as the rate at which it is released to the atmosphere. The movement of carbon between the various carbon sources and sinks is called the carbon cycle. The

three components of the carbon cycle are carbon in the atmosphere in the form of carbon dioxide, carbon in living and dead terrestrial and aquatic plants, and carbon dioxide dissolved in ocean water.

Carbon sinks can serve to reduce increases in atmospheric greenhouse gases, but the removal is not immediate, unlimited, or without deleterious side effects.

First, consider the anthropogenic production of carbon (6.3 billion tons per year) relative to inventories in the atmosphere (730 billion tons), in terrestrial vegetation and soil (2,000 billion tons), and in the oceans (38,000 billion tons)¹ (see Figure 19-3). The annual anthropogenic contributions to atmospheric carbon are a bit less than one percent per year of the total atmospheric inventory.

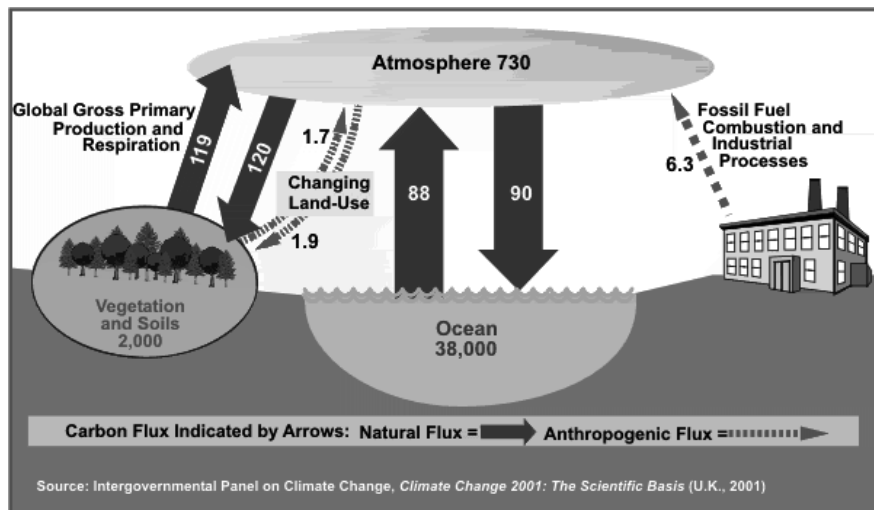

Figure 19-3. The Carbon Cycle
(courtesy of Intergovernmental Panel on Climate Change)

Measurements of atmospheric carbon dioxide have been made for air samples taken atop Mauna Loa in Hawaii². The graph of the data appears in Figure 19-4. The sawtooth behavior is due to seasonal variations in the nat-

ural absorption of carbon dioxide by plants and in carbon dioxide release through microbial aerobic digestion of dead plant matter. The clear upward trend of carbon dioxide concentration is the concern in the context of global warming. The increase in atmospheric carbon concentration is about 1/2 percent per year.

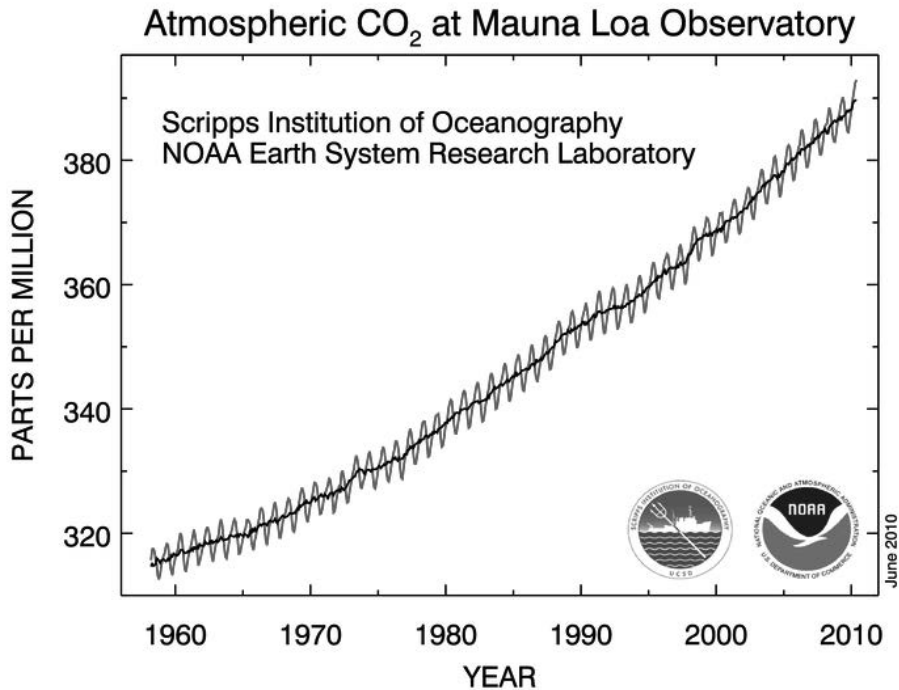

Figure 19-4. Carbon Dioxide Measurements at Mauna Loa
(courtesy of National Oceanic and Atmospheric Administration)

The fate of carbon introduced into the atmosphere depends on the exchanges between the three carbon reservoirs. Around 120 billion tons of carbon per year move back and forth between the atmosphere and terrestrial vegetation and soils, and around 90 billion tons per year move back and forth between the atmosphere and the oceans.

The difference between the carbon release rate into the atmosphere (around 1 percent of inventory per year) and the measured increase in carbon inven-

tory (around 1/2 percent) is due to transfer of carbon to the oceans and to terrestrial sinks. One consequence is an increase in the acidity of ocean water.

19.4 The Greenhouse Effect

Any changes in the radiation absorbed from the sun and/or changes in the radiation emitted by the earth will affect the earth's climate. The main human activities that cause changes in atmospheric carbon dioxide concentrations are fossil fuel combustion and deforestation. Both of these activities release carbon that previously had been isolated from the atmosphere.

Carbon dioxide is an important greenhouse gas because:

- It is the second most important absorber (after water vapor).
- It is released in energy production activities, mainly the combustion of fossil fuels.
- Its atmospheric concentration is increasing.

Some of the other greenhouse gases are even stronger absorbers of earth emissions than carbon dioxide, but they occur in much lower concentrations. Therefore, their effect is smaller. For example, methane enters the atmosphere through naturally occurring processes and through anthropogenic processes, but at a lower rate than carbon dioxide releases. However, a methane molecule has over 20 times the greenhouse effect of a carbon dioxide molecule. Limiting methane releases is second in importance only to limiting carbon dioxide releases in controlling global warming. The other greenhouse gases produce much smaller warming effects.

19.5 The Greenhouse Debate

There is no uncertainty about the physics that defines the cause-and-effect relation between atmospheric gases, photon absorption, and the greenhouse effect. Since the cause-and-effect relation between atmospheric gas concentration and global warming is firmly established science, the issue is whether the cause (increased concentrations of certain anthropogenic gases in the atmosphere) is capable of significantly altering the earth's climate.

Many publications provide historical climate data. The main issue is the change in climate in the period since the Industrial Revolution. If a noticeable climate change occurred following industrialization, it may be taken as a likely indicator of human impact. If, on the other hand, trends after industrialization are simply the continuation of trends that existed before industrialization, then non-anthropogenic causes are indicated.

The Intergovernmental Panel on Climate Change³ and the U.S. National Oceanic and Atmospheric Administration⁴ rely on the temperature, snow cover, and ocean level data shown in Figure 19-5. The trends starting in the late nineteenth century are apparent. These data support, but do not prove, the hypothesis that human activities are causing global warming.

Attribution of the source of increased carbon dioxide in the atmosphere relies on complex climate science. The essence of the main scientific argument rests on observation of the presence of isotopic variations of carbon isotopes in the atmosphere^{5,6}. There are three isotopes of carbon: carbon 12, carbon 13, and carbon 14. Carbon 12, a stable isotope with six protons and six neutrons in its nucleus, is the most common isotope, accounting for 99 percent of atmospheric carbon. Carbon 13, a stable isotope with six protons and seven neutrons in its nucleus, accounts for 1 percent of atmospheric carbon. Carbon 14, a radioactive isotope with six protons and eight neutrons in its nucleus, exists in trace amounts.

Carbon 14 is formed by reactions in the upper atmosphere between nitrogen and neutrons that are formed from cosmic rays. Carbon 14 has a half-life of 5,730 years. Until 1954, the equilibrium atmospheric carbon 14 con-

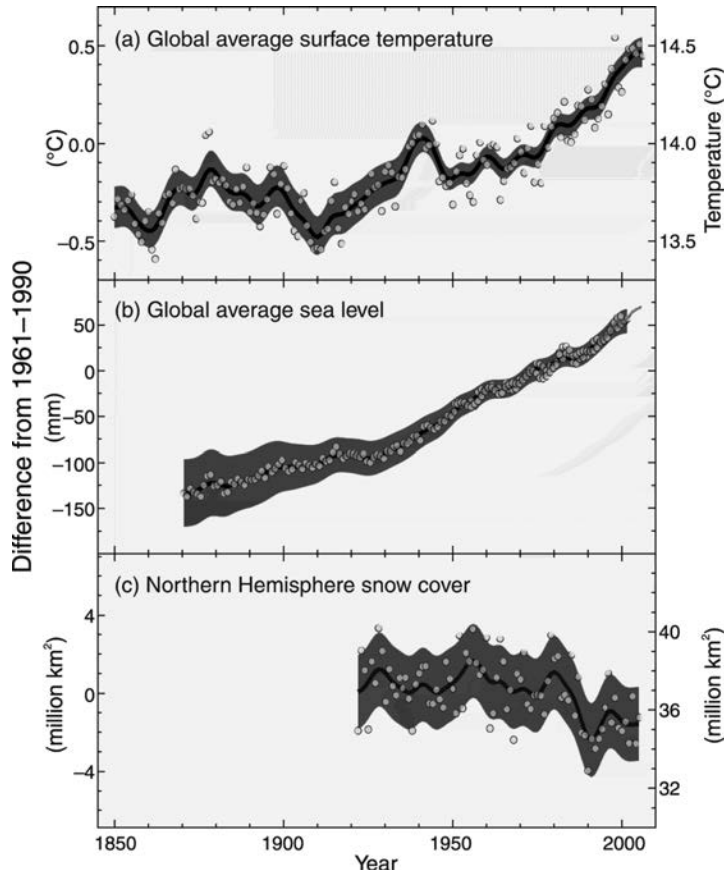

Figure 19-5. Climate-Related Changes
(courtesy of National Oceanic and Atmospheric Administration)

centration was the result of a balance between production in the upper atmosphere and loss by radioactive decay. After 1954, carbon 14 resulting from nuclear bomb tests altered the equilibrium. However, carbon 14 in tree rings provides a record of carbon 14 concentrations in recent decades. Carbon-containing materials that are isolated from the atmosphere have a steadily decreasing concentration of carbon 14 as radioactive decay proceeds. After several tens of thousands of years, the carbon 14 in isolated carbon is essentially gone. Such is the situation with fossil fuels that have been isolated for millions of years. Carbon with no carbon 14 will be called “old carbon,” meaning it has been isolated long enough for the carbon 14 to decay to insignificant levels.

Carbon 13 provides a clue to the source of carbon found in the atmosphere. Chemical reaction rates usually do not depend strongly on the isotopic form of the chemicals involved. Photosynthesis is an exception. Photosynthesis favors reactions with carbon 12 over reactions with carbon 13. Consequently, biomass has a reduced proportion of carbon 13 relative to carbon 12 in its constituents. Carbon with reduced carbon 13 will be called “biomass-derived carbon.”

The relative amounts of carbon 13 and carbon 14 in atmospheric carbon provide a signature that reveals the source of the carbon. Measurements show the percentages of carbon 13 and carbon 14 in the atmosphere are decreasing^{3,5,6}.

The decrease in the percentage of carbon 14 in the atmosphere indicates the added carbon is from a source that has been isolated from the atmosphere long enough for the carbon 14 to decay away. Fossil fuels and carbon-containing rocks have this property.

The decrease in the percentage of carbon 13 in the atmosphere indicates the source of the added carbon is one that originated in biomass. Fossil fuels have this property, and carbon-containing rocks do not.

The conclusion suggested by the carbon isotopic data is that the increase in atmospheric carbon is due to old and biomass-derived carbon. This is the characteristic of carbon that is released from the combustion of fossil fuels. Carbon from deforestation is “new carbon.”

Of course, attribution of the cause of global warming requires consideration of all of those processes that can alter the balance between incoming solar energy and the emission of radiation from the earth.

The solar radiation reaching the earth may be altered by the following:

- Changes in the reflection of solar radiation back into space. (The fraction of incident radiation that is reflected into space is called the

albedo, and its value is around 0.30. Suspended particulate matter (aerosols) in the atmosphere affects the albedo by providing sites that reflect sunlight. Aerosols may originate naturally (from events such as volcanic eruptions) or anthropogenically.

- Changes in the sun's energy output. (The sun's radiation emissions naturally undergo periodic small changes in intensity.)
- Changes in the earth's orbit around the sun and/or in the orientation of the earth's axis relative to the plane defined by the earth's orbit. (The earth's elliptical orbit around the sun undergoes shape changes that alter the earth-to-sun distance. The tilt of the earth's axis is known to have changed in the past, thereby altering the pattern of solar energy absorption.)
- Changes in the concentration of gases that absorb incoming solar radiation. (A change in absorption of incident radiation is not a greenhouse effect, but it can affect the energy balance. A change in atmospheric absorption of ultraviolet light by ozone is more of a health issue than a climate issue.)

Climate scientists analyzed and evaluated all of the processes described above before reaching a conclusion about the causes for observed climate changes. The scientific consensus is that changes in the earth's energy balance are occurring, and that these changes are due to increased atmospheric absorption of earth's emissions. Furthermore, the consensus is that greenhouse gas concentration is increasing, that there is conclusive evidence that the increases are largely caused by human activities, and that the increases are causing increases in the earth's average temperature. The scientific consensus is expressed in numerous reports, the most important being those from the Intergovernmental Panel on Climate Change (IPCC)³, a panel working under the auspices of the United Nations and the World Meteorological Organization.

A more difficult climate science question is the quantitative relationship between atmospheric greenhouse gas concentration and the resulting tem-

perature rise. It would be quite simple to develop a good mathematical model if the earth were a homogeneous solid body surrounded by a stagnant gas. In reality, the earth is very inhomogeneous, has a majority of its surface covered by water, and is surrounded by a very mobile mixture of gases and water vapor. These factors complicate the development of reliable climate models. The main issues are nonlinearities and feedbacks.

Nonlinearities are phenomena that result in effects not being proportional to causes. Consider the hypothetical scenario of atmospheric warming causing the melting of a large glacier located on land. The melting water flows into the seas, causing a rise in sea level. Eventually, the warming causes the glacier to break off and fall into the sea, causing an additional, sudden rise in sea level. The sudden change in the effect of warming is a nonlinear effect. Such effects complicate the development of climate models.

Feedback is the return of the output from a system to combine with an external input and thereby augment or diminish the net input. For example, consider a gas furnace. The flow of gas to the furnace (the input) determines the room temperature (the output). A home thermostat uses the difference between the measured temperature and the desired temperature to feed back a signal to increase or decrease the heat input.

Feedbacks also occur in nature, and they can be negative or positive. They may even have both positive and negative effects. Consider a scenario in which greenhouse gases undergo an increase. This will initiate a surface water temperature increase, causing evaporation to increase. The resulting increase in cloud cover would reflect solar radiation and reduce the warming (a negative feedback because it counteracts the effect of the initiating event). On the other hand, the increases in atmospheric water vapor (a greenhouse gas) would increase the absorption of photons emitted by the earth, thereby increasing warming. This is a positive feedback because it augments the effect of the initiating event. The net effect would be determined by the relative strengths of the two processes.

Nonlinearities and feedbacks make climate modeling very complicated. Nevertheless, numerous climate models have been developed and are

undergoing continuous refinements. Some are extremely complex and require the most powerful computers for implementation. Validity is checked by calculation of climate changes from the past and making comparisons with measured data. Generally, the models do a good job of matching observed data. This gives confidence that the models are also capable of predicting future climate changes caused by increasing greenhouse gas concentration in the atmosphere. However, these comparisons do not prove conclusively that predictions of future climate are correct. The future may include much larger climate drivers and feedbacks than those seen in the past and may face new, unanticipated nonlinearities.

The inability to develop perfect models should not be a basis for minimizing or ignoring the impact of greenhouse gases on climate. Even though we cannot predict the exact temperature rise for a specified increase in greenhouse gas concentration, it is clear that the temperature will rise. Models based on various approximations give a range of values for estimated temperature rises. These results, along with historical temperature data, indicate anthropogenic global warming is happening, and it constitutes a serious problem.

However, there are still those (including some scientists) who disagree with this assessment. It is likely that some of those who discount warming due to anthropogenic greenhouse gas concentration increases are driven by their philosophy rather than by science. Mitigation of global warming would surely require some regulation of business and personal activities, and increased regulation is anathema to political and economic conservatives.

Continued disavowal of human-induced global warming in the face of the scientific evidence can only be based on the belief that the measurements or the interpretation of the measured data are flawed. The informed consensus is that this is not the case.

Those who disavow anthropogenic global warming represent a small minority of real or self-appointed climatologists, but they have received attention by the media and by government officials that is far out of proportion to their numbers. Their efforts have forced the scientific community to refine

its analyses and to improve its dialogue with the public and with policy makers. On the other hand, the efforts of those who deny global warming have fostered confusion, have caused diversion of effort and funds from more useful pursuits, and have caused delays in important work and mitigation efforts.

19.6 Mitigation

Reducing atmospheric greenhouse gas concentrations will require voluntary lifestyle changes by citizens or changes brought about by government involvement, such as by imposing regulations that must be satisfied in order to build and operate systems and facilities and/or by creating economic incentives through taxing practices that release greenhouse gases. Government actions can also encourage energy conservation, energy efficiency, and energy production practices (such as reliance on renewable and nuclear energy) that do not contribute to global warming.

World governments negotiated an international treaty, called the Kyoto Protocol⁷, designed to reduce atmospheric greenhouse gas concentrations. The protocol came into force in 2005. It had the goal of reducing collective world greenhouse emissions by 5.2 percent by 2012. Different countries were assigned different goals based on their emission levels and their state of economic development. The goals for individual countries may be higher or lower than the collective goal. Developing countries are excused from emission reduction in order to permit greater economic development. Countries in the developing category include China and India. Though the economies in these countries are considered to be in the developing stage, they are already major competitors in the world economy. The U.S. refused to ratify the Kyoto Protocol because of concerns that it would make U.S. industry less competitive with industry in exempt countries.

A key element of the mitigation strategy in the Kyoto Protocol is that of “emission trading.” Emission trading is based on the concept of Cap-and-Trade. In a cap-and-trade arrangement, greenhouse gas emitters have emission allowances. If an emitter produces less than its emission allowance, it

can sell emission credits to other emitters. The trading occurs between countries, between partnerships of multiple countries and between individual industrial emitters within a country. For example, an old power plant might be unable to meet its emission allotment without expensive system or operating changes. Credits could be purchased from another plant that emits less than its allowance. Critics say the cap-and-trade scheme only creates a new, cumbersome bureaucracy, it shifts the site where emissions occur, and it creates an unacceptable tax on energy production. However, the scheme creates an economic incentive for reducing emissions and thereby avoiding the need to purchase credits.

The Kyoto Protocol was difficult to negotiate, is limited in scope, and is caught in a conflict between compliance and competitiveness. As such, Kyoto must be viewed as a first step in developing effective international policies to reduce greenhouse gas emissions. A second climate change meeting was held in Copenhagen in 2009⁸. The U.S. and other developed countries made non-binding pledges to contribute billions of dollars to poor countries to help them in reducing carbon emissions. Copenhagen is generally viewed as a step forward, but with minimum real progress on controlling climate change.

It is noteworthy that some feel that we should simply adapt to climate change rather than trying to prevent it. For example, Lord Nigel Lawson⁹, former Chancellor of the Exchequer in Britain, argues that adaptation is preferable to mitigation efforts. If global warming proceeds as feared, some of the predicted consequences are the flooding of coastal cities and major changes in the location of land suitable for farming. These effects would lead to large migrations of people and would require a rebuilding of a large part of the infrastructure that supports modern society. The adaptation argument is valid only if the hardship of making these changes is less than the hardship of mitigation activities. No one knows the answer to the question of relative hardships. The rationale behind adaptation is that global warming may not occur, and, if it does, we can handle it.

19.7 Other Environmental Effects

Global warming is the energy-related environmental effect that has received the greatest attention. However, there are other byproducts of energy production that can harm people and damage the environment. The impacts on people and the environment are usually called external costs. These costs include pollution, ecosystem damage, changes in land use possibilities, and sickness or death of humans. External costs are impossible to determine unequivocally. It is difficult to attribute undesirable effects to specific causes, and it is impossible to put a standard value on something like sickness or death. Assessing external costs is further complicated by the delay that may exist between creating the impact and the appearance of resulting problems. Nevertheless, external costs are real, and it is certain that the true cost of energy production is significantly higher than current cost levels that ignore external costs. Examples of external costs follow:

Solids produced during energy-related activities constitute waste that must be stored, eliminated or recycled. (See Chapter 4.) These wastes often contain harmful components such as heavy metals or pathogens. Rain can dissolve harmful constituents of mine waste stored at mine sites. Water used to wash coal to remove dirt and rock can carry harmful materials into aquifers. Spillage of stored ash from a coal-burning power plant can contaminate land and water. The massive ash spill at the TVA Kingston Plant in 2008¹⁰ illustrates the problem.

Gases produced in fossil fuel combustion cause acid rain that can damage structures, damage farmland, and harm humans and animals. The main culprits are oxides of nitrogen and sulfur that react with atmospheric water to form acids.

Oil spills at well sites or during transport have produced major environmental damage. The Exxon Valdez oil tanker accident in Alaska¹¹ and the Deepwater Horizon drilling rig accident¹² in the Gulf of Mexico illustrate the problem.

Residents near natural gas wells that use hydrofracturing technology have experienced groundwater contamination by hydrocarbons and other chemicals. (See Chapter 4.) Residents in these locations have experienced increased disease and death, and they blame the wells. Some drilling proponents claim the residents' allegations are false or that the problems are unrelated to drilling, but questions remain.

Radioactive wastes were addressed in Chapter 11. Radioactive waste includes high-level waste from nuclear reactors and low-level waste from reactors, medical facilities, and industrial facilities. The volume of radioactive waste is much smaller than other forms of waste, but isolation from the human environment is essential.

Using land for energy production purposes can have undesirable environmental effects. For example, strip mining alters land unless it is fully remediated, and dams convert dry land into lakes and alter natural river flows. Coal extraction by mountaintop removal methods in Appalachia has left scarred landscapes.

19.8 Conclusions

There will be no attempt to prove or disprove conclusively in this book that anthropogenic global warming is occurring. Rather, it should be noted that the reality of anthropogenic global warming is supported by science, and by the interpretation of that science by the great majority of qualified scientists. Mitigation efforts have begun, but much remains to be done.

It should also be noted that concern about global warming is but one of two reasons to reduce the use of fossil fuels. The other is resource depletion. Those who dispute the need to curtail fossil fuel use must disavow both concerns.

References

1. Energy Information Administration Report “Greenhouse Gases, Climate Change and Energy”, November 2003 at <http://www.eia.gov/oiaf/1605/ggccebro/chapter1.htm>.
2. Earth System Research Laboratory, National Oceanic and Atmospheric Administration, <http://www.esrl.noaa.gov>.
3. “Climate Change 2007: The physical Science Basis” Report by the Intergovernmental Panel on Climate Change (the IPCC) at http://www.ipcc.ch/publications_and_data/publications_ipcc_fourth_assessment_report_wg1_report_the_physical_science_basis.htm.
4. National Oceanic and Atmospheric Administration at <http://www.noaa.gov>.
5. Mann, M. E. and Kump, L. R. “Dire Predictions: Understanding Global Warming” New York: DK Publishing, Inc. 2008.
6. Barbalace, R. C. “CO₂ Pollution and Global Warming” November 7, 2006 at <http://environmentalchemistry.com/yogi/environmental/200611CO2globalwarming.html>.
7. “Kyoto Protocol” at http://unfccc.int/kyoto_protocol/items/2830.php.
8. “Copenhagen 2009” Conference held December 6-18, 2009 at <http://www.erantis.com/events/denmark/copenhagen/climate-conference-2009>.
9. Lawson, N. “Time for a Climate Change Plan B” the *Wall Street Journal* December 22, 2009.
10. Dewan, S. “Coal Ash Spill Revives Issue of its Hazards” *The New York Times* December 24, 2008 at <http://www.nytimes.com/2008/12/25/us/25sludge.html?fta=y>.
11. Cleveland, C. “Exxon Valdez Oil Spill” *Encyclopedia of the Earth* at http://www.eoearth.org/article/exxon_valdez_oil_spill.
12. “DEEPWATER, The Gulf Disaster and the Future of Offshore Drilling” Report to the President by the National Commission on the BP Deepwater Oil Spill and Offshore Drilling, released on January 11, 2011. Available at the U.S. Government Printing Office.

Exercises

- 19-1. According to Figure 5-1, 4 units of solar energy are reflected by the earth for every 51 units of energy absorbed. All other energy effects occur in the atmosphere. Now consider a hypothetical earth with no atmosphere.
- A. How much energy would be absorbed per square foot per day?
 - B. How much total energy would be absorbed and re-emitted per day?
 - C. Estimate the temperature of an earth with no atmosphere. (See Appendix J.)
- 19-2. Water vapor has the largest greenhouse effect by far. So why are people worried about carbon dioxide?
- 19-3. Explain why the solar emission spectrum and the earth emission spectrum enter into the physics of the greenhouse effect.
- 19-4. Outline and discuss the data from historical records of average earth temperature, sea level, and snow cover. Include their relevance to attribution of the cause of climate change.
- 19-5. Why are the Mauna Loa data important with regard to the attribution of causes for climate change?
- 19-6. Outline and discuss the role of carbon isotopic data on attribution of the causes for climate change.
- 19-7. Use the Internet to find an article that debunks anthropogenic climate change. Prepare an evaluation of the article.

- 19-8. Use the Internet to discover whether there have been additional major international agreements since Kyoto and Copenhagen. If so, discuss and interpret your findings.
- 19-9. Cap-and-trade is a controversial issue in the U.S. as this book is being written. What is the current government policy on cap-and-trade in the U.S.?
- 19-10. What do you think should be done about charging for the external costs associated with energy production?
- 19-11. Nonlinear effects occur when effects are not directly proportional to causes. Is the relation between potential energy and height linear or nonlinear? How about the relation between kinetic energy and velocity? Describe an example of nonlinear behavior in everyday life.

20

Energy

Conservation

and Efficiency

The Main Points

- **Conservation and efficiency improvements are the quickest and cheapest ways to reduce energy consumption.**
- **Benefits of efficiency improvements range from cheap and immediate to expensive and long-term.**
- **40 percent of U.S. energy consumption is under the direct control of citizens.**
- **Energy used to provide goods and services accounts for 60 percent of U.S. consumption.**

20.1 Introduction

There have been many accounts in the media about ways to reduce energy consumption by implementing conservation and efficiency improvements. Previous chapters have described the technology behind these measures. This chapter provides a brief summary of efficiency improvement and conservation activities that can reduce energy consumption.

Energy conservation is the reduction of activities that consume energy. Improving energy efficiency is the reduction of energy needed to accomplish some activity.

Energy conservation and efficiency improvements are often touted as the quickest and cheapest ways to reduce energy consumption and related undesirable environmental effects. Some measures require lifestyle changes, and some require technological steps. Some lifestyle changes can occur with little or no negative impact on the quality of life. Some changes provide immediate payback, and others require investments that will provide payback in the future.

Individuals, businesses, and government all have a role.

20.2 Individual Actions

20.2.1 Purchases

The things that we purchase require energy to produce, package, and transport the products and to dispose of associated waste. The energy required for these operations is called embodied energy. Sometimes we have choices between different products that can serve the same purpose, but with significantly different embodied energies. Some examples of embodied energies are shown in Table 20-1.

Table 20-1. Embodied Energies¹

Material	Embodied Energy (BTU/pound)
Paper	15,500
Glass	10,900
PET Plastic ^a	46,500
Aluminum	62,000
Steel	9,300
^a Polyethylene terephthalate (PET): a plastic used for beverage containers	

Information about embodied energy can help consumers who want to help with energy conservation.

20.2.2 Residential Energy Use

Residential energy use accounts for around 21 percent of total American energy consumption. The breakdown of energy by type of use in residential consumption provides insight into the ways that energy is used (and possibly misused) in homes. Energy use data were presented in Table 15-1 and are shown here in Figures 20-1 and 20-2. See Table 15-2 for the breakdown of electrical energy use in homes. Possible savings in energy and its cost depend on the characteristics of the residence and the local climate. The

Department of Energy provides detailed information on options for residential energy savings².

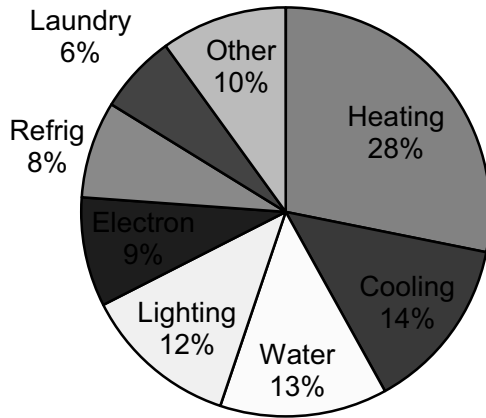

Figure 20-1. Residential Primary Energy End Uses

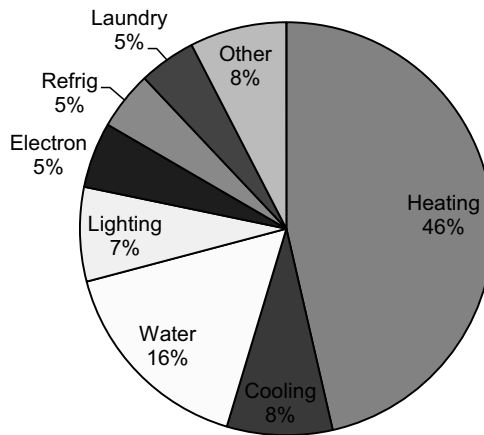

Figure 20-2. Residential Delivered Energy End Uses

Conservation in the Home

Conservation involves no cost, but may require acceptance of some loss of comfort or convenience. The most important residential conservation options are as follows:

- Reduce heating and cooling energy use by increasing thermostat settings in summer and reducing settings in winter.
- Set the thermostat to reduce heating and cooling energy even more when the home is unoccupied.
- Close vents and doors to unused rooms.
- Reduce or eliminate lighting in unoccupied rooms.
- Lower hot water temperature and reduce the quantity used for bathing or showering.
- Reduce energy use for laundry by washing only full loads and air drying (maybe even use outdoor clotheslines).
- In winter, open curtains when solar heating is available and needed and close curtains to reduce heat loss when solar heating is unavailable.
- In summer, close curtains when solar heating is available but unwanted.
- Open windows when outside air is at a comfortable temperature.
- Minimize the number of times that the refrigerator is opened. (Collect as many items as possible to be placed in the refrigerator before opening the door.)
- Use local heaters such as space heaters and electric blankets for heating highly local areas.

- Use fans in summer to achieve comfort with higher thermostat settings.
- Turn off electronic equipment when not in use.
- Unplug appliances and devices with phantom loads when not in use.
- Clean washable HVAC (heating, ventilating and air conditioning) filters regularly.
- Clean refrigerator coils regularly.
- Close the chimney flue (damper) when the chimney is not in use.
- In winter, leave bath water in the tub until it cools, thereby transferring heat and humidity into the living space.

Home Efficiency Upgrades Involving Little or No Cost

Energy efficiency measures that require small out-of-pocket expenditures are outlined below:

- Install a programmable thermostat (set to reduce heater or air conditioner operation when not needed).
- Install high efficiency lighting. Compact fluorescent lights cost three or four times as much as incandescent lighting, but use around one-third as much energy and last up to ten times as long.
- Seal around windows to close leaks.
- Weatherstrip doors to close leaks.
- Install low-volume shower heads.

- Plant deciduous trees on the south side of the home (provides shade in summer and admits sunlight in winter).
- Install storm doors and windows.
- Install exhaust fans to draw cool night air into the home in summer.

Home Efficiency Upgrades Involving Significant Cost

Upgrades of energy-consuming equipment and systems that involve significant cost will provide future rather than immediate cost savings. Owners must decide about future benefits versus current expenditures.

Major options are as follows:

- Replace the HVAC system with a more efficient model (possibly a ground effect heat pump or a dual-mode, heat pump+gas furnace system.)
- Replace appliances with more efficient models. (Refrigerators, washers, dryers, and dishwashers with improved energy efficiency are available.)
- Replace furnaces with units with greater efficiency. (Since the efficiencies of many existing furnaces are quite high, only small improvements are likely.)
- Replace water heaters with units having higher efficiencies (possibly the newer tankless types.)
- Insulate or upgrade insulation in walls, floors, and ceilings and around water heaters and pipes.
- Seal and insulate ductwork.
- Install energy efficient windows.

- Install an attic exhaust fan.
- Install on-demand lighting where appropriate.
- Install a solar water heater.
- Install a photoelectric system.
- Install retractable awnings.

New Home Construction

New homes can incorporate all of the measures described above and, in addition, apply measures that are impractical for retrofitting. Major options are as follows:

- Place the house and design it so most of the windows face south.
- Use smaller windows.
- Incorporate energy capture features such as Trombe walls (see Section 15.3.4).
- Incorporate an energy storage mass (thermal mass) to store heat. (Excess heat, usually daytime solar heat, is stored on winter days for subsequent release when needed. In summer, the mass is cooled with cool night air and then used to subsequently provide cool air when the daytime temperature rises.)
- Incorporate ground effect heat pumps. These are less expensive and less disruptive to install during initial construction (see Section 15.3.3).
- Incorporate a wastewater heat exchanger to heat incoming fresh water. This requires special plumbing, a storage tank to hold preheated water for future injection into the water heater, and a controller.

- Install dark-colored roofing for cold climates and light-colored roofing for warm climates.

Recycling

Recycling generally does not save energy or money for the individual home occupant. Instead, recycling may be done because of a sense of civic duty and/or because of local regulations. Because of the energy consumed and the manpower required for collection, hauling, sorting, and processing recycled materials, it is not always obvious that recycling reduces total energy use. However, studies show³ recycling metals, glass, and paper all reduce the energy required to produce new products relative to the energy required for production from raw materials. For example, recycled aluminum uses only about 5 percent of the energy needed to produce aluminum from bauxite ore. Recycling other materials reduces energy required by 25 to 75 percent. Recycling also reduces the rate of depletion of ores and forests, and it reduces the volume of material placed in landfills.

20.2.3 Transportation Energy Use

Energy use for transportation accounts for around 27 percent of American energy use. Personal transportation accounts for 59 percent of transportation energy use. The Department of Energy provides detailed information on options for reducing the energy needed for personal transportation⁴.

Conservation in Personal Transportation

The most important energy conservation measures in personal transportation are as follows:

- Reduce driving by careful route planning to accomplish required tasks with minimum travel distance. (For example, wait until several stops in a given area are required before traveling.)
- Reduce driving by carpooling.
- Reduce driving by using public transportation.

- Avoid high speed driving.
- When possible, travel when congestion is light.
- Avoid unnecessary braking by gradual deceleration before stops.
- Eliminate driving to work when work-at-home options are available.
- Use teleconferencing instead of face-to-face meetings when possible.
- Avoid trips for comparison shopping by using the telephone and/or the Internet.
- Adopt a four-day work week when possible.

Transportation Efficiency Upgrades with Little or No Cost

- Perform regular vehicle maintenance.
- Maintain proper tire inflation pressure.

New Vehicle Purchases

Vehicle buyers face choices that will impact the energy efficiency of their travel. Some options will reduce initial cost (for example, a smaller car), and some will increase initial cost (for example, a plug-in hybrid). The buyer must weigh initial capital outlay versus lifetime costs.

Major options for increasing transportation energy efficiency in new vehicle purchases are as follows:

- Buy a small vehicle.
- Avoid high performance vehicles with large, high-horsepower engines.

- Buy a hybrid vehicle.
- Buy an all-electric vehicle for urban commuting.

20.3 Business and Industry Actions

Because of their constant concern about profitability, businesses and industry are more likely than private citizens to implement energy efficiency measures. Commercial businesses use about 18 percent of total U.S. energy, and industry uses about 33 percent.

The main measures for retail, wholesale, and service businesses are the same as those for individuals, but the relative impact of each depends on the differences in facilities and mode of operation. The U.S. Department of Energy provides detailed information on reducing energy needed in commercial buildings⁵ and in industry⁶.

Some energy-saving measures that businesses can take are:

- Install photovoltaic systems.
- Optimize delivery routes to minimize energy use.
- Use energy-efficient (possibly electric) vehicles for deliveries.
- Install zone control to use lighting, heating, and cooling only when needed.
- Upgrade insulation.
- Install skylights and fluorescent lighting.
- Install energy-efficient windows.

Energy efficiency measures that may be taken by industry are somewhat different than in residences and businesses and include the following:

- Install cogeneration equipment.
- Install heat recovery systems.
- Replace auxiliary equipment such as fans, pumps, and motors with more efficient models.
- Implement improved control strategies and install new control equipment.
- Seal leaks.
- Insulate piping and process equipment.
- Install advanced boilers and furnaces.
- Recycle waste material.

20.4 Government Actions

20.4.1 Tax Credits

The government can and does offer tax credits for selected energy-saving investments. These credits reduce the effective cost of items and increase the incentive to purchase them.

20.4.2 Regulations

The government mandates performance standards for energy-consuming systems. For example, the CAFE (Corporate Average Fleet Efficiency) standard imposes mileage requirements for the mix of automobiles manufactured by an automaker.

20.4.3 Being an Example

The government itself is a major energy consumer. Improvement in the energy efficiency of government facilities and vehicles demonstrates possibilities and limitations. In addition, government expenditures for energy-saving measures encourage the market to expand and innovate.

20.4.4 Research

The government funds energy research and encourages commercialization of appropriate new technology.

20.4.5 Education

The government provides information that is needed to understand energy-related issues. Information from government sources is especially valuable because it is considered less biased than information from business sources.

20.5 How Individual Citizens Use Energy

We have seen American citizens use about 330 million BTU per person per year. This includes direct energy use and indirect energy use. Direct energy use includes energy for personal travel and energy for providing personal comfort and convenience. Indirect energy use includes the energy consumed in producing, hauling, and selling the *stuff* that we use. Table 20-2 shows the relative energy use for these activities.

These statistics do not account for energy used to produce U.S. exports or for energy used to produce U.S. imports. Since America is a heavy importer, the actual total energy consumption that is required for each U.S. citizen is slightly higher than the U.S. figures cited.

We have seen in previous sections that viable options already exist for reducing energy for direct use. The largest reductions are possible with transportation and for lighting and appliances. Savings of as much as 50

Table 20-2. Energy Use by an Average American

Activity	Percentage of Per Capita Energy Use
Direct Use	
Personal Transportation ^a	19
Home Heating and Cooling	8
Home Water Heating	3
Home Lighting and Appliances	<u>10</u>
Total Direct	40
Indirect Use	
Producing Stuff ^b	35
Hauling Stuff	8
Selling Stuff	<u>17</u>
Total Indirect	60
^a Includes travel on buses and aircraft	
^b "Stuff" as defined here is the total of goods and services consumed	

percent are possible in these applications, but they can only be realized as older items are replaced with newer, energy-efficient items. Decisions must be made about replacements when existing systems end their useful life and when new systems offer annual savings that may justify replacing systems that are still operable. Such savings would reduce total annual consumption and expenditures by as much as 15 percent.

Reducing indirect energy use is also possible, but achieving reductions is more complicated. Industrial production is driven by profitability, and profitability depends on production costs and consumer demand. Production costs include raw material cost, energy cost, labor cost, debt service, taxes, and compliance cost. The government impacts production costs through regulations, taxes and/or incentives, and consumers impact demand for specific products by their purchasing decisions.

Government and citizens can influence indirect energy use, but every decision requires an informed assessment of costs and benefits. For example, if government policies and personal choices lead to the increased use of hybrid or electric cars, total energy consumption for transportation decreases, but this requires increased electricity production, transmission,

and distribution. If the increased electricity is provided with new coal-burning power plants, then increases in greenhouse gas release and pollution become an issue.

20.6 The Bottom Line

The energy conservation and efficiency measures outlined above do not include estimates of the actual energy savings. Estimating energy savings is hampered by strong dependence on local conditions where measures are implemented, on the extent of the changes that are made, and on assumptions about their effectiveness. However, it is safe to say that no single measure is a panacea. Each measure can provide small incremental improvements. Fortunately, there are many energy-saving opportunities and, if a number of them are implemented, their cumulative effect will be significant.

References

1. MacKay, D. "Sustainable Energy—Without the Hot Air" Cambridge: Cambridge University, 2009 (available free at <http://www.withouthotair.com>).
2. "Energy Savers: Tips on Saving Money & Energy at Home" U.S. Department of Energy, Energy Efficiency and Renewable Energy at http://www.energysavers.gov/pdfs/energy_savers.pdf.
3. Choate, A. et.al. "Waste Management and Energy Savings: Benefits by the Numbers" Study for the U.S. Environmental Protection Agency, 2005, at <http://www.epa.gov/climatechange/wycd/waste/downloads/Energy%20Savings.pdf>.
4. "Tip: Driving and Car Maintenance" U.S. Department of Energy, Energy Efficiency and Renewable Energy at <http://www.energysavers.gov/tips/driving.cfm>.
5. "Commercial Building Design Guide" Commercial Building Initiative U.S. Department of Energy, Energy Efficiency and Renewable Energy at http://www1.eere.energy.gov/buildings/commercial_initiative/guides.html#strategies.
6. "Industries and Technologies" Advanced Manufacturing Office U.S. Department of Energy, Energy Efficiency and Renewable Energy at http://www1.eere.energy.gov/manufacturing/industries_technologies/.

Exercises

- 20-1. On a winter day, the outside temperature is 30°F , and the indoor thermostat is set at 70°F . Estimate the percentage of energy use that would be saved if the thermostat were set at 68°F . (Hint: Remember heat transfer is a gradient-driven process.)
- 20-2. How much energy is required to produce 3,000 pounds of steel used in an automobile? How many gallons of gasoline would provide the same energy?
- 20-3. Developed nations are currently (at the time of this writing) moving toward the elimination of incandescent light bulbs in favor of compact fluorescent lamps. Estimate the total reduction in U.S. electricity consumption if all residences switch to CFLs.

Part IV:
**CREATING
SUSTAINABLE
ENERGY**



21

Energy

**Economics and
Government**

The Main Points

- **World population growth will cause increases in energy demand.**
- **U.S. per capita energy consumption is about twice that of western European countries and 8-1/2 times that of developing countries.**
- **Resource availability and environmental protection concerns will limit growth in energy use and in the world economy.**
- **Technical advances like those that enabled earlier growth are unlikely.**
- **Government and economic policy must eventually adapt to a no-growth situation.**

21.1 Introduction

Previous chapters should have made it clear that achieving a sustainable energy supply that satisfies human requirements is a huge challenge. We must implement one or more of the following steps:

- Produce more energy
- Stabilize or decrease population
- Reduce per capita consumption

Energy supply is strongly coupled with economic forces and government policies. This coupling is the stuff of economics and politics, subjects outside of the main focus of this book. Nevertheless, their importance in determining our energy future warrants a short detour into these subjects.

21.2 Energy Production

Future energy production decisions will be driven by three considerations: the declining availability of traditional energy resources, the relative costs of energy options, and concerns about environmental damage caused by the use of energy resources. In spite of these concerns, it is certain the world's energy demand will increase.

21.3 Population

A major reason for the increase in world energy demand will be increasing populations of citizens in developing countries who want the lifestyle benefits of increased energy use.

Currently, birth rates are decreasing, but they remain high in developing countries. Demographers estimate the world population will stabilize in the mid-twenty-first century at about 50 percent higher than the current population (see Chapter 14).

21.4 Per Capita Consumption

In 2010, the U.S., with only about 5 percent of the world's population, accounted for about 20 percent of the world's energy use. The existence of much lower per capita consumption in some other advanced nations suggests that America could reduce consumption without huge changes in lifestyle. For example, the 2010 per capita energy consumption as a percentage of U.S. per capita consumption in three large European countries is as follows: France (51 percent), Germany (50 percent), and Great Britain (47 percent). Furthermore, even these economies have waste that could be eliminated, further reducing consumption. These statistics give support to the assertions by some that the U.S. could reduce its per capita consumption by half without excessive difficulty. Of course, there are also those who say that European conditions are so different from U.S. conditions that comparisons are useless.

U.S. energy policies and consumption habits do not function in isolation. The rest of the world consumes four-fifths of world energy production, and important changes in consumption patterns in these countries are imminent. Even if the U.S. decreased its energy consumption to half of its current level, world energy consumption would decrease by only about 10 percent. The U.S. per capita energy consumption is now about 8-1/2 times that of citizens in countries that are now classified as “developing.”

China and India, with about one-third of the world’s population, are increasing their energy appetites significantly, and much greater increases are anticipated in the near future. The economies and the lifestyle expectations in the huge populations of these countries are growing rapidly. Total energy consumption in China grew to equal U.S. consumption in 2009. In the early twenty-first century, the per capita energy use in China and India is small compared to the U.S. because of much larger populations in those countries (23 percent of U.S. per capita consumption in China and 6 percent in India). People in these and other developing countries will certainly demand the energy needed to improve their lifestyles. There will be intense competition for energy resources and a strong temptation to ignore environmental effects in the rush to increase energy production.

21.5 Economics

Economics, often called the *dismal science*, is the discipline concerned with the allocation of scarce resources to satisfy human wants. So long as humans cannot have everything that they want, scarcity is said to prevail. Human wants include those things that are essential (food, water, shelter, energy) and those things that add convenience, comfort, entertainment, and culture to human existence.

World population, economies and energy consumption have been growing exponentially for many years. Predicting future economic conditions is hampered by the non-intuitive nature of exponential growth. People tend to think in terms of linear change but growth generally proceeds exponentially (see Section 2.11).

There is a fundamental conundrum in economics: *All economies are designed to grow continuously, but resource availability and environmental protection impose an inescapable upper limit on growth.* The states of national economies are measured by their gross domestic products (GDP), and the states of businesses are measured by their annual profits. Failure is indicated by a decrease in GDP or profits. But this growth cannot continue indefinitely. The question is not whether there are limits to growth, but whether the world is close enough to these limits to necessitate attempts to adapt to them.

Economists and politicians pay little attention to the future impact of resource availability and environmental effects on economic policies. Discussions about the link between economics and energy production usually focus on two issues: the failure of prior predictions of economic hardship caused by resource (especially energy) unavailability and the link between energy costs and economic growth.

Predictions of the catastrophic consequences of resource depletion have appeared repeatedly in the past. The most famous is probably Thomas Malthus' eighteenth century prediction of chaos caused by population increases that would outstrip the world's ability to meet basic survival requirements with available resources. Malthus and most of the subsequent prognosticators failed to account for the technological advances that would expand the earth's carrying capacity. For example, prognosticators failed to account for the Industrial Revolution in the nineteenth century and the Green Revolution in the twentieth century.

Many economists now rely on "the lessons of history" to posit that technology will provide the means to enable sustainable and continued growth in population and consumption. However, a growing number of analysts believe we have finally reached the start of a new era, in which resource unavailability and/or environmental issues will prevent continued unrestrained growth¹.

Economists, including those involved in formulating U.S. economic policy^{2,3}, often speak out on the link between energy and economics, but the focus is on the impact of energy prices on economic growth. The objec-

tive is low energy prices and continued economic growth. It is now obvious that the need to deal with short-term issues is in direct conflict with the need to deal with the long-term issue of inevitable growth limits.

Eventually, the objective in economic policy must change. There must be a transition to a new economy in which growth is stopped in order to enable a sustainable condition. The inevitability of this requirement is certain, but the necessary schedule is very uncertain. Some say that the time for action is so far in the future that it does not warrant concern. Others say that the time for action is now.

The connection between resource availability and economic growth was addressed in a 1972 study by The Club of Rome and documented in the book titled *The Limits to Growth*.^{4,5} This book, with 30 million copies sold in 30 different languages, has stimulated debate, but its conclusion is undeniably correct. *Growth cannot continue forever*. The main theme of *The Limits to Growth* is echoed in other, more recent publications.^{6,7}

21.6 Government

Throughout history, citizens of the countries of the world have debated and fought over decisions about the form of government that suits them best. At one extreme is government that embraces free-market capitalism. At the other extreme is government that embraces central planning by an individual (in absolute monarchies and dictatorships) or by a bureaucracy (in socialist systems) to control production and the distribution of wealth. No countries now operate at these extremes. Instead, they operate systems that involve a mixture of these disparate philosophies.

The economic and government philosophy in the U.S. supports a free-market, capitalistic system. It is based on the belief that the laws of supply and demand and the striving for personal gain will work to the betterment of everyone. However, the need to share the cost of certain activities that are deemed desirable has led to departures from pure capitalism. Medicare, welfare, punitive taxation, graded income tax, subsidies for certain industries,

and minimum wage laws are all examples of central planning that influences the distribution of wealth.

Governments have a crucial role in bringing about a transition to energy sustainability. Taxes, regulations, subsidies, education, persuasion, and research funding are tools available for government to influence the direction and rate of a transition to sustainability. Decisions about the form and extent of government policies are made by bureaucrats who have imperfect knowledge and insight and whose decisions are influenced by their personal beliefs and philosophies. Heavy government involvement will certainly be anathema to those citizens and politicians who favor minimum government central planning and control. Nevertheless, governments clearly must eventually adapt to an unavoidable no-growth policy.

In the early twenty-first century, the U.S. and the world experienced an economic recession. Many believe it was caused by so-called “casino economics.” People made investments, primarily in real estate and the stock market, essentially betting that values would continue their pattern of rapid growth. When apparent assets plummeted in value as real estate and stock values dropped, the U.S. government responded by providing funds to encourage a return to growth. Government measures included bailouts of troubled sectors of the economy (mainly financial institutions and auto manufacturers) and tax rebates to citizens. These steps were designed to encourage production and consumption. These steps helped in returning to a growth economy, but there was little indication of any inclination to use the slowdown as an opportunity to begin a transition to sustainability (an exception was encouragement of auto manufacturers to produce more fuel-efficient vehicles).

Dealing with future energy supply shortages will force consideration of major restructuring of the U.S. and world economic and government systems. The main question is, “How can per capita consumption be reduced while maintaining the incentives for innovation and improvement that are inherent to the free market system?” This issue will inevitably arise in the future, and it is important for economists, politicians and private citizens to start planning for the transition.

References

1. Krautkraemer, J. A. “Economics of Natural Resource Scarcity: The State of the Debate” Discussion Paper 05-14, *Resources for the Future* April 2005. at <http://www.rff.org/rff/documents/rff-dp-05-14.pdf>.
2. Greenspan, A. “Impact of Energy on the Economy” Speech before the Economic Club of Chicago, June 28, 2001.
3. Bernanke, B. “Energy and the Economy” Speech before the Economic Club of Chicago, June 15, 2006.
4. Meadows, D. M. et al. “The Limits to Growth; A Report for The Club of Rome’s Project on the Predicament of Mankind” New York: Universe Books, 1972.
5. Simmons, M. R. “Revisiting the Limits to Growth: Could the Club of Rome be Correct After All?” an Energy White Paper, October, 2000, at http://greatchange.org/ov-simmons,club_of_rome_revisted.pdf.
6. Siegel, C. “The End of Economic Growth” Berkeley: Preservation Institute, 2006.
7. Hanson, Jay, “Energetic Limits to Growth” *Energy Magazine*, Spring 1999 at <http://jayhanson.us/netEnergy.pdf>.
8. Douthwaite, R. “The Problem with Economic Growth” at <http://www.feasta.org/1997/05/08/the-problem-with-economic-growth/>.

22

Summing Up

Previous chapters should have made it clear that the transformarians (whom we met in Chapter 1) have a lot of work to do. Four issues drive the urgency of transforming our energy habits:

1. The world's population will increase by an estimated 50 percent in coming decades.
2. Oil is running out.
3. Climate change concerns will constrain the use of fossil fuels.
4. Replacing traditional energy sources with sustainable sources will be slow, difficult, and expensive.

Previous chapters should also have made it clear that effective planning requires quantitative analysis of the current and future possibilities for dealing with energy issues. The performance of energy-producing and energy-consuming systems depends on the underlying science. The science is well established, well understood, fully verified, and, for the most part, quite simple. The science tells us what is possible and, probably more important, what is impossible. Science provides a framework into which we can insert real-world data and draw conclusions. But the science is only part of the story. The technology used to exploit the science determines whether an implementation is practical.

As populations grow and lifestyle expectations increase (especially in developing countries), energy needs will grow. This growth will outrun any reductions in energy consumption achieved through conservation and improved efficiency in energy production and consumption. America can certainly reduce its energy consumption through conservation and improvements in energy efficiency, but, because of growing consumption elsewhere, this will have little impact on total world energy requirements.

A major shift in the global energy consumption pattern started around 2000 when energy consumption in China began a rapid increase. Chinese energy consumption surpassed U.S. consumption in 2009. This book focuses on

energy in the U.S., but China's increasing appetite for energy influences every country through its impact on fuel cost, resource availability, and climate change. Energy consumption in India is also expected to grow rapidly in the twenty-first century. The emergence of these countries as major energy consumers illustrates that energy is a global issue.

Oil production in the U.S. peaked around 1970, and a dependence on imports has evolved, leading to a huge transfer of wealth to exporters and vulnerability to supply curtailments. Now, even the future availability of foreign oil is uncertain. Analysts say the world has used one-third to one-half of the recoverable oil that was originally in the ground. The oil already withdrawn has satisfied the world's energy appetite for over 100 years. But, because of the exponential nature of demand growth, the remaining reserves will not last nearly as long. The era of cheap and plentiful oil will be over in decades rather than centuries.

Natural gas has evolved from a nuisance to be eliminated by burning to a treasured energy source. The change came about when pipelines were built to carry gas from wells to users. America's natural gas reserves include so-called unconventional deposits. These reserves are huge, but extraction requires the fracturing of underground, gas-bearing rocks. This is a complex process, with the potential for the release of harmful chemicals into the water and air. Nevertheless, unconventional gas already provides a significant portion of America's gas, and further increases are anticipated. It is not yet known whether environmental and health issues will limit the production of unconventional gas or require changes in drilling technology.

Coal, oil shale, and oil sands contain a very large quantity of recoverable energy. Coal use has several major drawbacks, including carbon dioxide release, pollution, and the undesirable consequences of mining operations. Producing fuel from oil shale or oil sands faces cost and environmental protection issues. Using its large reserves of coal and oil shale would help reduce U.S. dependence on foreign energy sources, but cost and environmental concerns may limit production. Canada faces similar issues with its reserves of oil sand.

There are still those who claim that either climate change is not occurring, or, if it is, it is a natural phenomenon that is unrelated to human activities. There is no uncertainty in the science that relates climate to atmospheric gases such as carbon dioxide and methane. There is also no doubt that human activities result in the release of these gases into the atmosphere. Finally, there is no doubt that atmospheric carbon dioxide and the earth's average temperature are increasing. The overwhelming consensus among climate scientists is that human activities are causing climate change, and curtailment of releases is necessary to prevent unacceptable consequences.

A transition to sustainable U.S. energy will require a huge shift in our energy infrastructure. The technologies that can (and almost certainly will) contribute to weaning America from fossil fuel dependence are solar heating, solar electricity, biofuels, wind energy, hydroenergy, geothermal energy, and nuclear energy.

Solar energy can be used either directly or indirectly, through other energy forms that derive their energy from sunlight. Biofuels, wind, and hydroenergy are all resources that get their energy from the sun.

Solar heating involves collecting solar energy and, in some cases, storing it for later use. Solar collection schemes range from architectural designs that optimize solar home heating in winter to solar collectors that are constructed to maximize energy capture.

Several methods exist for producing solar electricity. Since solar electricity systems can operate only when the sun is shining, provision must be made for providing energy by other means when solar energy is unavailable. Photoelectric devices can produce electricity in small-scale applications (such as private homes) or in large solar farms with thousands of square feet of collector surface. Photoelectric system use is growing. Costs are still high, but they are dropping. Solar heat engines can also serve as large-scale electricity producers. Solar energy may be used to boil a fluid that drives a turbine-generator or power a Stirling engine or (more speculatively) to heat air that rises through a tall chimney, driving a turbine-generator along the way.

Biofuels such as ethanol, butanol, and biodiesel are potentially important replacements for oil-based fuels. The major limits on biofuel production are determined by total suitable land availability, competition with land use for producing food, water usage for growing plants, and effects on soil fertility. Plants store chemical energy derived from solar energy during photosynthesis. It is quite simple to calculate the possible range of stored energy per acre of land used to grow plants. This type of calculation shows that biofuel can contribute significantly to future transportation fuel needs, but cannot yield as much energy as is currently obtained from oil-based fuel because of the acreage required. Satisfying transportation energy needs will require a major shift to electricity. Batteries or fuel cells can supply electricity for transportation by using grid electricity to create chemical energy that can be converted back into electricity when needed.

Wind possesses kinetic energy that can be captured by wind turbines. Like solar energy, wind energy is also intermittent. Huge turbines with electric power outputs as great as seven megawatts are being installed, usually in large wind farms. The best locations for wind farms in the U.S. are in Midwestern states and along some coastlines. For wind energy to achieve its full potential, new transmission lines must be built from producer regions to user regions. Building coastal installations (generally off-shore) depends on overcoming cost, durability, aesthetic, and environmental concerns.

Hydroenergy is the energy in moving or falling water. Hydroelectric dams exist throughout the U.S., but suitable sites for large hydroelectric systems have all been used. However, contributions to future electricity needs could be made using smaller dams, natural elevation changes in rivers, river current turbines, ocean current turbines, tidal energy converters, and wave energy converters.

Geothermal energy may be the dark horse in the race to sustainable energy. Enough energy to satisfy all human needs is contained in hot rocks located within six miles of the earth's surface. In some locations, hot rocks exist near the surface, and there is a natural source of water that picks up heat from these rocks. These formations, called hydrothermal sources, are already being used for producing electric energy in some locations. How-

ever, the energy in hot, dry rock is many times greater than the energy in hydrothermal formations. The trick to exploiting hot, dry rock is to fracture it (to permit fluid to flow through it) and to introduce a fluid (generally water) to carry heat to the surface. These geothermal systems are called enhanced geothermal sources or engineered geothermal sources. The problem of modifying huge volumes of underground rock and supplying adequate and controlled quantities of heat transfer fluid is daunting, but the potential reward is great.

Nuclear reactors that employ fission of heavy nuclei now produce about 20 percent of America's electricity. Reactors in the U.S. have operated safely for many years, and new designs have additional safety features. In 2011, just as a consensus seemed to be developing that nuclear reactors are safe, practical, and necessary, the catastrophic accident occurred at the Fukushima power plant in Japan. The Fukushima accident has rekindled concerns about reactor safety and casts doubt on a resurgence of the U.S. nuclear industry.

Fusion reactors, based on the fusion of light nuclei, are a potential huge energy source for the future. However, building a practical fusion reactor is a much larger challenge than building a fission reactor. Decades of research have provided a good understanding of the physics involved, but the design and construction of an operable reactor are yet to be done.

Energy transport is the movement of energy resources or energy carriers (such as electricity) from their source to the sites where they are used. Pipelines provide the most efficient means for transporting liquid and gaseous fuels. If biofuels and/or hydrogen become important, their transport by pipeline will require major new construction. Trains, trucks, and barges can be used for transporting coal, liquid fuels, and gaseous fuels within the U.S., but the use of trucks is much less energy efficient than the other options. Intercontinental transport of liquid and gaseous fuels requires special ships.

Expected increases in the use of electricity will require increasing the capacity of the electrical grid by new construction and by implementing Smart

Grid technology. Required grid capacity can be reduced by local electricity production, such as by solar or wind power systems, but overall it is clear that expanding the electrical grid, as well as the remainder of the energy transport system, will be expensive but necessary.

All the technologies mentioned above are likely to play a role in satisfying future energy needs. The relative importance of each technology remains uncertain. It is clear, however, that energy issues will result in major impacts on our personal habits, our business practices, and our government policies.

The story told in preceding chapters should make it clear that we face problems in supplying future energy, but we have the means to deal with these problems. What will be needed is commitment, informed decision-making, and hard work.

APPENDICES



APPENDIX A: MASS AND WEIGHT

This appendix addresses the proper use of measures of mass and weight in the mathematical formulas that express the laws of physics. The proper handling of these measures is quite simple, but confusion and misuse are commonplace. The discussion begins with a discussion about mass and weight for the SI system (for *Système International d'Unités*) followed by a similar discussion for the U.S. Customary system. The awkward U.S. Customary system label is often shortened to the American system.

Definitions of terms for SI units involved in the following discussion appear below:

- **Mass:** A measure of an object's tendency to maintain its state of motion (inertia)
- **Weight:** The force on a body of a certain mass due to gravity
- **Kilogram of mass:** Declared mass of a metal block stored in Paris (approximately equal to the mass of 1,000 cubic centimeters of water)
- **Meter of length:** Originally defined as length of a metal rod in Paris. Currently defined as the distance travelled by light in a specific time interval
- **Second of time:** Declared as $1/86,400$ of the mean solar day ($86,400 =$ the number of seconds in a day)
- **Newton of force:** Force capable of accelerating one kilogram by one meter per second per second
- **Joule of energy:** One Newton-meter
- **Watt of power:** One Joule per second

First, let us consider potential energy. Newton's Second Law says that force is mass times acceleration:

$$F = ma \quad (A-1)$$

The work done by the application of a force is the force times the distance moved, d :

$$W = Fd \quad (A-2)$$

Since energy is defined as the capacity to do work, the potential energy of a body experiencing a force is the work that would be done if the body were released to respond to the force. For example, an object held at some height above the surface of the earth experiences gravitational force that would accelerate the object toward the surface if the object were released. The force on the object would be:

$$F = mg \quad (A-3)$$

where:

g = the acceleration due to the gravitational force

The weight of an object is the force due to gravity.

The work done by the falling object (equal to the potential energy change of the object) would be:

$$E = mgd \quad (A-4)$$

At this point, it is necessary to define the quantities in Equation A.4. The SI system (also called the MKS system) uses meters, kilograms and seconds for units of length, mass and time. All of these quantities were arbitrarily assigned. The acceleration of gravity, g , is a measured quantity that depends on where it is measured. Values of g on the surface of the earth vary slightly with location because of small variations in the earth's diameter and com-

position. A good representative value is 9.81 meters per second per second. (An object falling under gravitational force will increase its velocity by 9.81 m/sec for every second that it falls if no other forces are present.)

Mass is an intrinsic property of an object, but the weight of the object depends on gravity where the object is located.

Example A.1

Consider a one hundred kilogram mass on the surface of the earth. It weighs 981 Newtons. On the moon, where the acceleration due to gravity is 1.62 meters per second per second, the object would still have a mass of 100 kilograms, but its weight would be 162 Newtons.

Now consider the measurement system commonly used in the U.S. It is called the U.S. Customary system or the FPS system (because of the use of feet, pounds and seconds). Here is where confusion creeps in, often baffling students of physics and engineering and occasionally causing catastrophic errors in engineering design calculations. The problem is the pound. Its definition has undergone several different incarnations in the past, but is now defined strictly as a **force**, not a mass.

We begin the discussion of the U.S. Customary system as we did previously for the SI system, with Newton's Second Law:

$$F = ma \tag{A-5}$$

If the force under consideration is gravity, then:

$$F \text{ (pounds)} = mg \tag{A-6}$$

Since the pound has been declared a unit of force in the U.S. Customary system:

$$\text{mass} = (\text{force in pounds})/g \tag{A-7}$$

The unit of mass in the U.S. Customary system is called the slug. The acceleration due to gravity in U.S. Customary units is 32.17 feet per second per second. To illustrate, an object that weighs 100 pounds has a mass of $100/32.17 = 3.11$ slugs.

The confusion arises because the difference between mass and weight is important in some applications and not important in others. A man in America might say that he weighs 220 pounds. Since weight is a force and pounds measure force, this statement is entirely correct. The same man in France would say that he weighs 99.8 kilograms. But, this statement is not really correct because kilograms measure mass, not weight. In this case, it does not matter. (In France, the man would have been correct if he had said that his weight is the force exerted by 99.8 kilograms of mass.)

In America and France, the scale would measure force, probably by stretching a calibrated spring or by balancing the man's weight against known weights. Since the acceleration due to gravity is essentially the same anywhere on the surface of the earth, all of the units of mass and weight are proportional to one another, and the scale can be calibrated in any of these units. So the 220 pound man is also a 99.8 kilogram man or a $220/32 = 6.8$ slug man or a $9.81 \times 99.8 = 979$ Newton man. All of these measures are correct and consistent so long as the man stays on the surface of the Earth.

Americans are all familiar with pounds as a unit of weight, but few have even heard about slugs as a unit of mass. Europeans (and many Americans) are familiar with kilograms as a unit of mass, but few have even heard of Newtons as a measure of force or weight. This is not a serious problem until one embarks on assessments of physical quantities such as potential energy or kinetic energy. In evaluating potential energy and kinetic energy, it is crucial to distinguish between mass and weight.

In the SI system, potential energy, PE, is given by:

$$\text{PE(Joules)} = 9.81 \times m(\text{kilograms}) \times h(\text{height in meters}) \quad (\text{A-8})$$

In the U.S. Customary system:

$$PE(\text{foot pounds}) = w(\text{pounds}) \times h(\text{height in feet}) \quad (\text{A-9})$$

Converting between SI and U.S. Customary units for energy is based on the relationship one foot pound = 1.356 Joules.

Example A.2

Consider the 220 pound man standing on a three meter (9.842 feet) diving board. His potential energy in SI units is:

$$\begin{aligned} E(\text{Joules}) &= 9.81 \times 99.8 \times 3 \\ &= 2,940 \text{ Joules} \end{aligned}$$

In U.S. Customary units:

$$\begin{aligned} PE(\text{foot pounds}) &= 220 \times 9.842 \\ &= 2,165 \text{ foot pounds.} \end{aligned}$$

Converting foot pounds to Joules gives:

$$\begin{aligned} PE(\text{Joules}) &= 2165(\text{foot pounds}) \times 1.356(\text{Joules per foot pound}) \\ &= 2,940 \end{aligned}$$

This is the same as obtained in the SI evaluation.

Now consider kinetic energy, KE:

$$KE = (1/2)mv^2 \quad (\text{A-10})$$

For kinetic energy evaluations, the mass in kilograms (SI system) or slugs (U.S. Customary system) is required.

Example A.3

Consider a 100 kilogram object traveling at 10 m/s. The kinetic energy is:

$$\begin{aligned} KE(\text{Joules}) &= (1/2) \times 100 \times 10^2 \\ &= 5,000 \text{ Joules.} \end{aligned}$$

The 100 kilogram mass corresponds to a weight of 220.46 pounds in the U.S. Customary system. This weight corresponds to $220.46/32.17 = 6.853$ slugs. The velocity in U.S. Customary units is 32.808 feet per second. So the kinetic energy in U.S. Customary units is:

$$\begin{aligned} KE(\text{foot pounds}) &= (1/2) \times 6.853 \times (32.808)^2 \\ &= 3,688 \text{ foot pounds.} \end{aligned}$$

Converting from foot pounds to Joules gives:

$$\begin{aligned} KE(\text{Joules}) &= 1.356 \text{ (Joules per foot pound)} \times 3688 \text{ (foot pounds)} \\ &= 5000 \text{ Joules.} \end{aligned}$$

APPENDIX B: CONVERSION FACTORS

Some of the conversion factors needed in energy assessments appear below.

Length

Multiply	by	To Get
Centimeters	0.01	meters
	0.03281	feet
Feet	0.3048	meters
Meters	100	centimeters
	3.281	feet
Miles	5,280	feet
	1,609	meters
	1.609	kilometers
Kilometers	1,000	meters
	0.6215	miles
	3281	feet

Area

Multiply	by	To Get
Acres	0.405	hectares
	43,560	square feet
	4,047	square meters
Hectares	10,000	square meters
	2.47	acres
Square feet	0.0929	square meters
Square meters	10.76	square feet

Mass and Weight on Earth's Surface

(Grams, kilograms and metric tons, often written as tonnes, are units of mass. Pounds and short tons are units of weight. Mass and weight are proportional on the surface of the earth. The proportionality results in the following equivalencies on the surface of the earth. To emphasize the distinction between units of mass and units of weight, units of mass are shown in italic font and units of weight are shown in regular font.)

Multiply	by	To Get
<i>Grams</i>	0.001	<i>kilograms</i>
	0.002205	pounds
<i>Kilograms</i>	1,000	<i>grams</i>
	0.205	pounds
	0.001	<i>metric tons</i>
	0.0011	short tons
Pounds	453.5	<i>grams</i>
	<i>0.4535</i>	<i>kilograms</i>
	0.0005	short tons
Short tons	2,000	pounds
	907	<i>kilograms</i>
	<i>0.907</i>	<i>metric tons</i>
<i>Metric tons</i>	1,000	<i>kilograms</i>
	2,205	pounds
	1.1025	short tons

Volume

Multiply	by	To Get
Gallons (U.S.)	3.79	liters
	0.1336	cubic feet
	0.003785	cubic meters
Gallons (Imperial)	1.20	gallons (U.S.)
Cubic feet	28.3	liters
	0.485	gallons (U.S.)
	0.02832	cubic meters
Cubic meters	35.31	cubic feet
	264.2	gallons (U.S.)
Liters	0.2642	gallons (U.S.)

Speed

Multiply	by	To Get
Feet per second	0.6818	miles per hour
	1.097	kilometers per hour
	0.3048	meters per second
Meters per second	2.237	miles per hour
	3.600	kilometers per hour
	3.2808	feet per second
Miles per hour	1.467	feet per second
	1.609	kilometers per hour
Kilometers per hour	0.6215	miles per hour

Energy

Multiply	by	To Get
BTUs	1055	Joules
	252	calories
	0.293	watt-hours
	0.000293	kilowatt-hours
Joules	0.948×10^{-3}	BTU
	0.239	calories
	2.777×10^{-7}	kilowatt-hours
	0.737	foot-pounds
Foot-pounds	1.356	Joules
Exajoules	10^{18}	Joules
	0.9479	Quads
	0.948×10^{15}	BTU
Zetajoules	10^{21}	Joules
	1,000	exajoules
Kilowatt-hours	3,413	BTU
	3.6×10^6	Joules
Megawatt-hours	3.412×10^6	BTU
Quads	10^{15}	BTU
	1.055	exajoules
	24.8	MTOE
	0.0334	terawatt-years
Million tonnes of oil equivalent (MTOE)	4.0×10^{13}	BTU
	0.04	Quads
	0.0425	exajoules
	1.18×10^{10}	kw-hours

Power

Multiply	by	To Get
Watts	1	Joules per second
	0.001	kilowatts
	3.412	BTU per hour
Kilowatts	1,000	watts
	3,412	BTU per hour
	81,888	BTU per day
	29.9×10^6	BTU per year
Megawatts	10^6	watts
	1,000	kilowatts
	3.412×10^6	BTU per hour
	81.89×10^6	BTU per day
	29.9×10^9	BTU per year
Terawatts	10^{12}	watts
	10^9	kilowatts
	10^6	megawatts
	29.9×10^{15}	BTU per year
	29.9	quads per year
BTU per hour	0.2931	watts
Horsepower	0.746	kilowatts
	2545	BTU per hour
Quads per year	0.0334	terawatts
Exajoules per year	0.9478	quads per year

APPENDIX C: FUEL HEATING VALUES

Heating values for fuels define the energy that is released upon combustion. The heating value depends on the state of the combustion products (vapor or liquid). The product of concern is water, a combustion product of fuels that contain hydrogen. Vaporization of water requires energy input, and condensation releases an amount of energy that is the same as that required for vaporization. Consequently, two different heating values are used: high heating value or HHV for combustion with liquid water as a product and low heating value or LHV for combustion in which water vapor is a product.

Coal, the predominant solid fuel, has properties that vary significantly. Consequently, ranges of heating values must be relied upon for characterizing the energy available from coal combustion. Because of the dependence of heating values on coal composition, it is meaningless to specify different values for HHV and LHV. Ranges of heating values for the three types of coal are as follows:

Sub-bituminous.....	8,300 to 11,500 BTU per pound
Bituminous.....	10,500 to 14,000 BTU per pound
Anthracite.....	nearly 15,000 BTU per pound

Heating values for some important liquid fuels appear in Table C-1.

Table C-1. Liquid Fuel Heating Values

FUEL	LHV		HHV	
	BTU/LB	BTU/GAL	BTU/LB	BTU/GAL
Crude Oil	18,400	129,700	19,600	138,400
Gasoline	18,700	116,000	20,150	125,000
Diesel Fuel	18,400	129,000	19,800	139,000
Propane	19,900	84,300	21,500	91,200
Ethanol	11,600	76,300	12,800	84,300
Methanol	8,600	57,300	9,800	65,200
Butanol	14,800	99,600	16,100	106,500

Source of liquid fuel data: Argonne National Laboratory at http://www.transportation.anl.gov/modeling_simulation/GREET/index.html (This URL accesses the GREET web site that contains the above data.)

Heating values for some important gaseous fuels appear in Table C-2.

Table C-2. Gaseous Fuel Heating Values

FUEL	LHV		HHV	
	BTU/LB	BTU/CU FT	BTU/LB	BTU/CU FT
Methane	21,433	910	23,811	1,011
Ethane	20,295	1,630	22,198	1,783
Carbon Monoxide	4,368	323	4,368	323
Natural Gas	17,500-22,000	850-1,050	19,500-22,500	950-1,150
Hydrogen	51,628	275	61,084	325

Note: The volumetric heating values for gaseous fuels are evaluated at standard temperature and pressure.

Note: The LHV and HHV for carbon monoxide are the same. There is no water formed in the combustion of carbon monoxide.

Note: The range for natural gas is due to variations in gas composition from different sources.

Source of data on gaseous fuels: The Engineering Toolbox at <http://www.engineeringtoolbox.com>.

Note: The heating values for hydrocarbons are all around 20,000 BTU per pound.

APPENDIX D: STIRLING ENGINES

Consider a cylinder containing a gas and a piston as shown in Figure D-1. Application of heat to the cylinder causes the gas to expand. The gas pressure increases and the piston moves up, thereby performing work. If more work is required from this system, the gas must be cooled to reduce the pressure and allow the piston to return to its initial position. Repeated heating and cooling of the cylinder could produce work continuously, but this approach would be slow and cumbersome. The Stirling engine provides a more practical way to obtain work by heating and cooling a gas. Stirling engines use a flywheel to maintain motion when the pistons are not delivering energy.

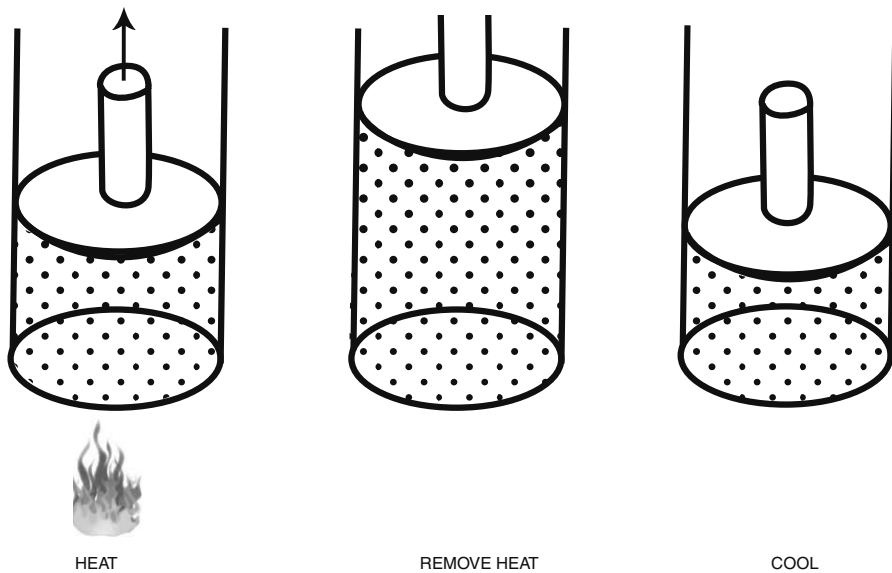

Figure D-1. Heating and Cooling a Contained Gas

The Stirling engine exists in many design variations, all of which are simple but elegantly clever. Some types have one cylinder and some have two cylinders. One type, a basic two-cylinder Stirling engine design, appears in Figure D-2. The system has four main parts:

- A heated cylinder and piston.
- A cooled cylinder and piston.
- A flywheel.
- A heat storage/transfer chamber called a regenerator, which is contained in the passage between the two cylinders. The regenerator may be a metal mesh. Its purpose is to transfer heat rapidly with hot or cold gases as they pass through, and to store heat.

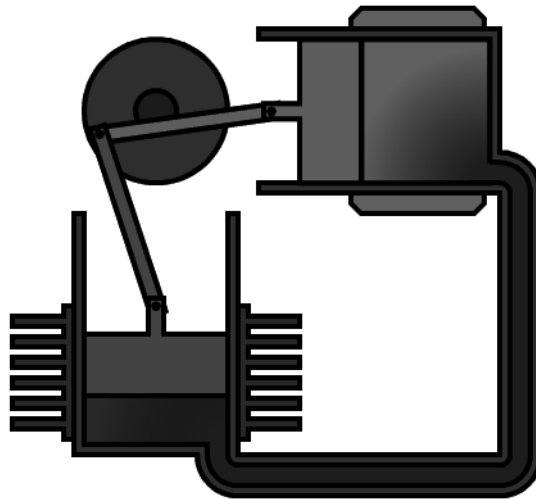

Figure D-2. A Stirling Engine (Richard Wheeler, Wikipedia, CC BY-SA 3.0 Unported)

The operation of the basic Stirling engine begins with the engine at rest and at constant temperature and pressure throughout.

To start engine operation, apply heating to one cylinder and cooling to the other. The system responds as follows:

- The gas in the heated cylinder expands.

- The gas in the cooled cylinder contracts.
- The increased gas pressure in the heated cylinder pushes the piston out and turns the flywheel clockwise to the position shown in Figure D-2.
- Flywheel motion causes the piston in the cooled cylinder to move outward.
- The piston in the heated cylinder reaches the limit of outward motion.
- The pressure difference causes gas to flow through the regenerator into the cooled cylinder. (The hot gas deposits much of its heat in the regenerator).
- The reduced pressure in the heated cylinder and the increased pressure in the cooled cylinder cause the heated piston to move inward and the cooled piston to move outward (Figure D-3).

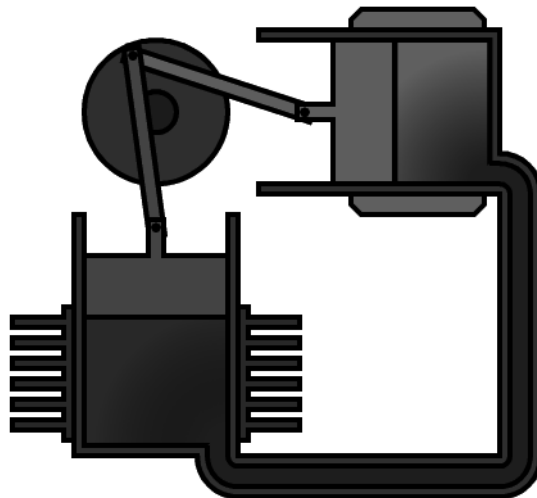

Figure D-3. Stirling Engine Operation (Richard Wheeler, Wikipedia, CC BY-SA 3.0 Unported)

- Flywheel angular momentum causes further rotation, driving the heated piston in and pulling the cooled piston out (Figure D-4).

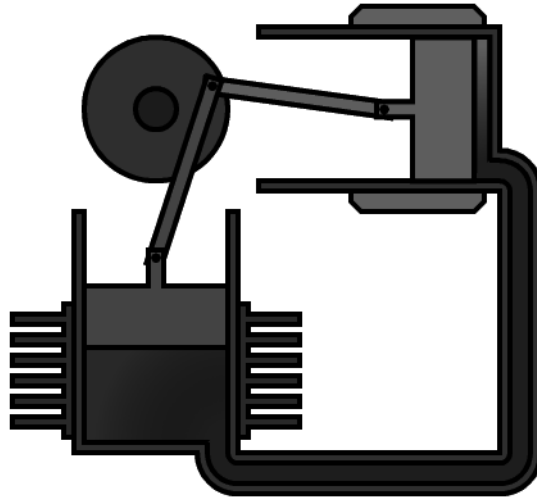

Figure D-4. Stirling Engine Operation (Richard Wheeler, Wikipedia, CC BY-SA 3.0 Unported)

- Flywheel rotation pushes the cooled piston inward, driving gas through the regenerator and back into the heated cylinder (Figure D-5).
- The gas in the heated cylinder expands because of applied heat and recaptured heat from the regenerator. This completes a cycle and the system is configured to start the next cycle.

The beauty of the Stirling engine is its simplicity and its ability to operate with any heat source, including solar heat. The Stirling engine described above is but one of many different versions. A web search on “Stirling engines” will provide information on these systems.

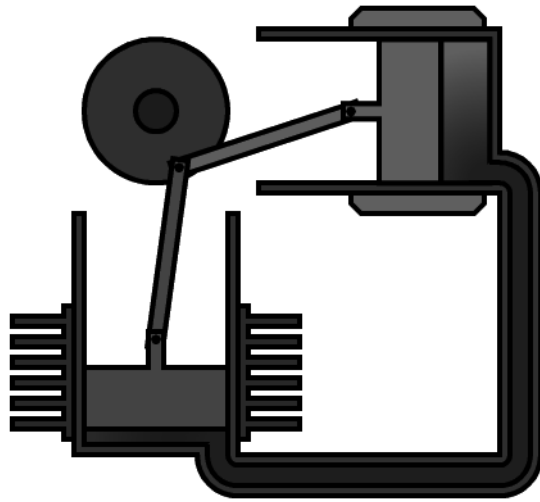

Figure D-5. Stirling Engine Operation (Richard Wheeler, Wikipedia, CC BY-SA 3.0 Unported)

APPENDIX E: ENERGY-RELATED WEBSITES

The following is a sampling of some of the more important energy-related web sites. There was no attempt at completeness in compiling this list. Most are present because they were useful to the author during the preparation of this book (primarily the period from 2005 through 2011). However, they provide an entrée into the vast web resource. Links to additional sources of energy information may be found at some of these sites.

Readers should note that web sites, and the content of web sites, are subject to change. As time passes, sites can become more or less pertinent, disappear or appear anew as time passes.

Government Agencies

Biomass Research and Development Initiative:
www.bioproducts-bioenergy.gov

Argonne National Laboratory: www.anl.gov

Argonne National Laboratory Center for Transportation Research:
www.transportation.anl.gov

Energy Efficiency and Renewable Energy (part of the U.S. Department of Energy): www.eere.energy.gov

Energy Information Administration (part of the U.S. Department of Energy): www.eia.doe.gov

Environmental Protection Agency: www.epa.gov

National Aeronautics and Space Administration: www.nasa.gov

National Renewable Energy Laboratory: www.nrel.gov

Oak Ridge National Laboratory: www.ornl.gov

Office of Science and Technology Information: www.osti.gov

Tennessee Valley Authority: www.tva.gov

U.S. Department of Agriculture: www.usda.gov

U.S. Department of Energy: www.doe.gov

U.S. Geologic Survey: www.usgs.gov

White House: whitehouse.gov

Research Organizations and Universities

Florida Solar Energy Center: www.fsec.edu

Geothermal Energy Association: www.geo-energy.org

Iowa State University Center for Sustainable Environmental Technology: csetweb.me.iastate.edu

Massachusetts Institute of Technology: www.mit.edu

National Transportation Research Center: www.ntrc.gov

University of California at Berkeley, Energy and Resources Group: www.socrates.berkeley.edu

University of California at Berkeley, Renewable and Appropriate Energy Group: www.rael.berkeley.edu

Princeton University, Carbon Mitigation Initiative: www.princeton.edu/~cmi

University of Tennessee, Agricultural Policy Analysis Center: www.apac.web.ag.utk.edu

University of Tennessee, Bio-Based Energy Analysis Group: www.beag.utk.edu

University of Tennessee, Institute for a Secure and Sustainable Environment: isse.utk.edu

Commercial: Energy Supply Companies

British Petroleum: www.bp.com

Non-Profit Groups

Alliance to Save Energy: www.ase.org

American Coalition on Ethanol: www.ethanol.org

American Council for an Energy Efficient Economy:
www.aceee.org

American Council on Renewable Energy: www.acore.org

American Solar Energy Society: www.ases.org

American Wind Energy Association: www.awea.org

Australian Institute of Energy: www.aei.org

Biomass Council: www.biomasscouncil.org

Center for American Progress: www.americanprogress.org:

Center for Resource Solutions: www.resource-solutions.org

Clean Energy Group: www.cleanegroup.org

Clean Energy States Alliance: www.cleanenergystates.org

Clear the Air: www.cleartheair.org

Climate Solutions: www.climatesolutions.org

Database of State Incentives for Renewable Energy: www.dsire-usa.org

Energy Future Coalition: www.energyfuturecoalition.org

Environmental and Energy Study Group: www.eesi.org

European Renewable Energy Council: www.erec-renewables.org

European Union, New and Renewable Energies:
www.europa.eu.int/comm/energy/res/index_en.htm

Geothermal Energy Association: www.geo-energy.org

Green Building Alliance: www.gbapgh.org

Green Renewable Electricity Certification: www.green-e.org

International Energy Agency: www.iea.org

Interstate Renewable Energy Council: www.irecusa.org

National Biodiesel Board: www.biodiesel.org

National Hydropower Association: www.hydro.org

Natural Resource Defense Council: www.nrdc.org

Pew Center for Climate Change: www.pewclimate.org

Renewable Energy Policy Project: www.repp.org

Renewable Fuels Association: www.ethanolrfa.org

Rocky Mountain Institute: www.rmi.org

Solar Energy Industries Association: www.seia.org

Union of Concerned Scientists: www.ucsusa.org

U.S. Green Building Council: www.usgbc.org

Utility Wind Integration Group: www.uwig.org

Worldwatch Institute: www.worldwatch.org

World Energy Council: www.worldenergy.org

APPENDIX F: OIL DEPLETION ANALYSIS: THE HUBBERT SOLUTION

Introduction

This Appendix addresses the forecasting of future oil production by the famous Hubbert method. Because of the importance of the forecasting method and the lack of rigorous and understandable descriptions of Hubbert's method in the literature, this appendix is more detailed than most of the text.

Oil is a finite resource that is steadily being used up. There is no doubt that decreasing reserves will eventually slow production. The growth of cumulative oil produced exhibited a slow start, followed by a rapid exponential growth. This growth must taper off as total depletion is approached.

Such an epoch is called a gradient-driven process. The following example provides an illustration of the general behavior of a gradient-driven process. Heat conduction was chosen for this example because such a process relates intuitively to common experience.

Example F.1

Heat conduction in a solid is driven by temperature gradients. Initially, an interior point in a mass responds only slightly to a surface temperature change. Visualize dropping a cool brick into a large tank of hot water. The center of the brick is largely “unaware” that anything has changed at the surface until heat has diffused to the center. The interior temperature then undergoes a rapid rise until the rising interior temperature reduces the temperature gradient between interior points and the surface. This gradient eventually disappears and the brick’s interior stabilizes at the same temperature as the surrounding water. A plot of the center temperature versus time would be a distorted S shape.

Many processes in diverse fields such as population growth and chemical reactions follow an S-shaped response curve. The curve is called a sigmoid, and any of a number of equations that define sigmoid curves is called a sigmoid function. A sigmoid function conforms to the logical progression of oil depletion: slow initial growth, then rapid increase, then tapering off.

Logistic Function Modeling

In developing mathematical models for processes such as cumulative oil production, the analyst fits available data to an equation that is thought to represent the process. This involves assigning values for coefficients in the model that cause the model to best agree with available data. Once the model coefficients have been found, the model equation can be used to estimate results outside the region where data are available. Basically, the model equation is an extrapolation or interpolation tool.

The choice of the model to be used may be empirical, semi-empirical or theoretical. Empirical models are based on equations that have no theoretical foundation at all. Essentially, the analyst asserts no knowledge about the form of the relationships between cause and effect. Semi-empirical models are based on limited theoretical knowledge. For example, choosing a sigmoid as the model would be based on logic that indicates the general way the process will have to unfold. A purely theoretical model is based on detailed understanding of the process and the equation that describes it.

The numerical values of the coefficients in the model are obtained by fitting the model to available data.

The semi-empirical approach is the best approach possible in an effort to use available information to predict future oil production. Theoretical modeling of all possible factors related to oil production (population, economic conditions, wars, etc.) is impossible.

A sigmoid function often used in oil forecasting is the logistic function. The idea of the logistic function is to combine the exponential growth observed in early phases of resource utilization with the slowing of growth that must occur as total depletion is approached. Exponential growth occurs when the current rate of growth of cumulative production Q at any time is proportional to the cumulative production at that time. The differential equation for exponential growth is as follows:

$$dQ/dt = aQ \quad (F-1)$$

where:

a = a constant (a method for determining its value is presented below)

The growth must slow as total depletion is approached. One way to approximate this behavior is to assume that the factor, a , decreases linearly with cumulative production. That is:

$$dQ/dt = (a-bQ)Q \quad (F-2)$$

The value of the factor, b , may be determined by noting that dQ/dt must be zero when the cumulative production reaches the point of total depletion and Q is equal to Q_t , the total quantity of resource produced over all time:

$$0 = (a-bQ_t)Q_t \quad (F-3)$$

or:

$$b = a/Q_t \quad (F-4)$$

Thus, the growth model becomes:

$$dQ/dt = a(1-Q/Q_t)Q \quad (F-5)$$

or:

$$dQ/dt = aQ-(a/Q_t)Q^2 \quad (F-6)$$

Since dQ/dt is simply the annual rate of production, P , we may write:

$$P/Q = a(Q_t-Q)/Q_t \quad (F-7)$$

This equation reveals that, according to the logistic premise, a plot of P/Q versus Q should be a straight line. The intercept on the P/Q axis is the value of the constant, a . This value may be obtained from a graph of P/Q vs Q .

Equation F-6 is a nonlinear differential equation (because of the Q^2 term). Exact analytical solutions are not known for all nonlinear differential equations, but the solution for this one is known. The solution is as follows:

$$Q = Q_t/(1+\exp(-at)) \quad (F-8)$$

The validity of this solution can be verified by substituting the solution for Q in Equation F-6 and checking for equality.

The production rate, P , at any specified time is equal to dQ/dt . P may be calculated by substituting values of Q from Equation F-8 into Equation F-6.

The solution also depends on a specific initial condition (the condition when elapsed time is zero). The initial condition implicit in the solution may be identified by setting $t = 0$ in Equation F-8 as follows:

$$Q(0) = Q_t/2 \quad (F-9)$$

That is, time is measured from the instant when cumulative production is half of the cumulative production at the time of total resource depletion. Values of cumulative production after the half consumption point are obtained by substituting positive values of t into Equation F-8, and values before the half consumption point are obtained by substituting negative values of t .

The analysis presented above gives cumulative production and annual production for times measured relative to the time of peak production. It is necessary to convert to true calendar time. In this analysis, the curve will be normalized by forcing it to agree with known prior production in a prior year. Equation F-7 may be rewritten as follows:

$$(Q/Q_t)^2 - (Q/Q_t) + (P/aQ_t) = 0 \quad (F-10)$$

Equation F-10 is a quadratic equation with two solutions, given below:

$$(Q/Q_t) = (1 + \text{sqr}(1 - (4P)/(aQ_t)))/2 \quad (F-11)$$

and:

$$(Q/Q_t) = (1 - \text{sqr}(1 - (4P)/(aQ_t)))/2 \quad (F-12)$$

These solutions give the fractional cumulative production on both sides of the peak. The second solution (with the minus sign) applies for times before the peak.

The time relative to the time of peak production may be found by evaluating Q/Q_t for specified values of P , a and Q_t using Equation F-12, then solving Equation F-8 for t as follows:

$$t = -(\ln((1 - Q/Q_t)/(Q/Q_t)))/a \quad (F-13)$$

where:

\ln denotes the natural logarithm.

This value of t is the time before the time of peak production. It gives the number of years by which time relative to the time of peak production must be shifted to give calendar time.

A Computer Program

A BASIC language computer code has been prepared to perform a Hubbert analysis. Users must specify the following four inputs:

1. The intercept on the P/Q axis in a plot of P/Q vs Q (the constant, a , in Equation F-7)
2. The total recoverable reserves
3. The reference year
4. The production during the reference year

The program listing appears below:

```
10 print "Hubbert Peak Solution"  
20 print "Basis: solution of differential equation"  
30 print "Input intercept"  
40 input a  
50 print "Input total recoverable reserves"  
60 input Q1  
70 print "Input Reference Year"  
80 input y  
90 print "Input Production in Reference Year"  
100 input P
```

```
110 f = (1-sqr(1-(4*P/(a*Q1))))/2
120 t1 = (-1/a)*log((1-f)/f)
130 print
140 print
150 print "Year    Cumulative Production    Annual Production"
160 For t = -100 to -10 step 10
170 Q = Q1/(1+exp((-1)*a*t))
180 P = a*Q-(a/Q1)*Q*Q
190 print INT(y+t-t1),INT(Q),"    ",(INT(100*P))/100
200 next t
210 for t = -9 to 9
220 Q = Q1/(1+exp((-1)*a*t))
230 P = a*Q-(a/Q1)*Q*Q
240 print INT(y+t-t1),INT(Q),"    ",(INT(100*P))/100
250 next t
260 For t = 10 to 100 step 10
270 Q = Q1/(1+exp((-1)*a*t))
280 P = a*Q-(a/Q1)*Q*Q
290 print INT(y+t-t1),INT(Q),"    ",(INT(100*P))/100
300 next t
```

Readers can download a free Basic compiler from <http://www.justbasic.com>.

Analysis of U.S. Oil Depletion

The computer program was used to perform a Hubbert analysis for the lower 48 states. Using Deffeyes' (Ref. 1) values of 0.0536 for the intercept, a , and 228 billion barrels for total recoverable reserves, Q_t , a reference year of 1958 and a 1958 production value of 2.45 billion barrels, gives the following results:

Hubbert Peak Solution

Basis: solution of differential equation

Input intercept

?0.0536

Input total recoverable reserves

?228

Input Reference Year

?1958

Input Production in Reference Year

?2.45

APPENDIX F: OIL DEPLETION ANALYSIS: THE HUBBERT SOLUTION

Year	Cumulative Production	Annual Production
1875	1	0.05
1885	1	0.09
1895	3	0.16
1905	5	0.27
1915	8	0.45
1925	14	0.73
1935	23	1.14
1945	38	1.69
1955	58	2.32
1965	84	2.84
1966	87	2.88
1967	89	2.91
1968	92	2.95
1969	95	2.97
1970	98	3.00
1971	101	3.02
1972	104	3.03
1973	107	3.04
1974	110	3.05
1975	114	3.05
1976	117	3.05
1977	120	3.04
1978	123	3.03
1979	126	3.02
1980	129	3.00
1981	132	2.97
1982	135	2.95
1983	138	2.91
1984	140	2.88
1985	143	2.84
1995	169	2.32
2005	189	1.69
2015	204	1.14
2025	213	0.73
2035	219	0.45
2045	222	0.27
2055	224	0.16
2065	226	0.09
2075	226	0.05

Annual U.S. production predicted by the above Hubbert analysis appears in Figure F-1 along with actual data.

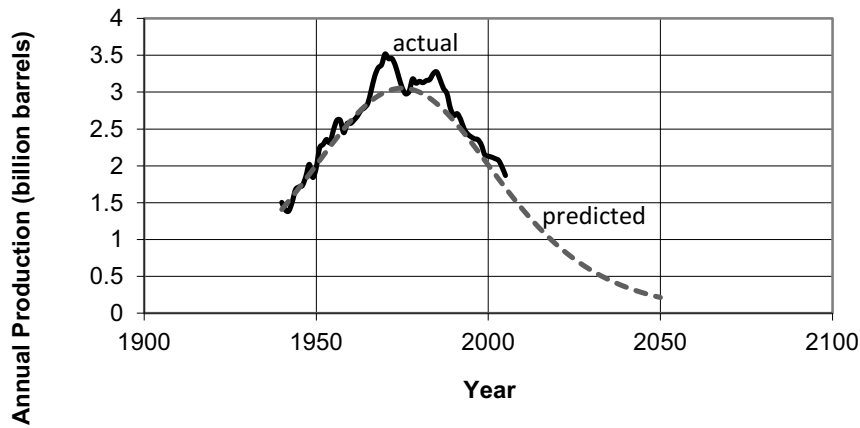

Figure F-1. Hubbert Prediction of Annual Production and Actual Production

For those who wish to work with historical U.S. production statistics for the lower 48 states to draw their own conclusions about trends and future production, data are available from the U.S. Energy Information Agency (<http://www.eia.gov>).

References

1. Deffeyes, K. S. *Beyond Oil* New York: Hill and Wang, 2005.

APPENDIX G: SOLAR RADIATION

Introduction

This Appendix provides a derivation of a simple model for solar radiation absorption at the earth's surface. This derivation shows the dependence on geometrical factors that vary with season, latitude and time of day. This simple model does not account for all of the factors that determine local solar radiation absorption, but it does illustrate the relation between geometric factors and solar radiation absorption.

The solar constant (the solar energy flux through space at the earth's outer atmosphere) is well known, with a value of 1370 watts per square meter¹, or 435 BTU per hour per square foot, or 10,434 BTU per day per square foot. For evaluation of the use of this energy for human purposes, the issue is determining the fraction of the solar energy stream that can be captured and used.

The intensity (power per unit of area) of the radiation reaching the earth's surface depends on two factors:

- The angle between the incoming beam and the surface at a location of interest
- The absorption and reflection of radiation by the atmosphere

The photons in the solar radiation beam emitted from the sun have a distribution of wavelengths that are determined by the sun's surface temperature. As the radiation passes through the earth's atmosphere, the spectrum is altered by atmospheric chemicals that selectively absorb photons of certain wavelengths. Since some energy-collection processes of interest (photosynthesis and the photovoltaic effect) require certain wavelengths, the spectrum of radiation reaching the surface is important in renewable energy considerations. Figure G-1 shows the spectrum of radiation reaching the earth's surface after experiencing atmospheric absorptions and scatterings¹.

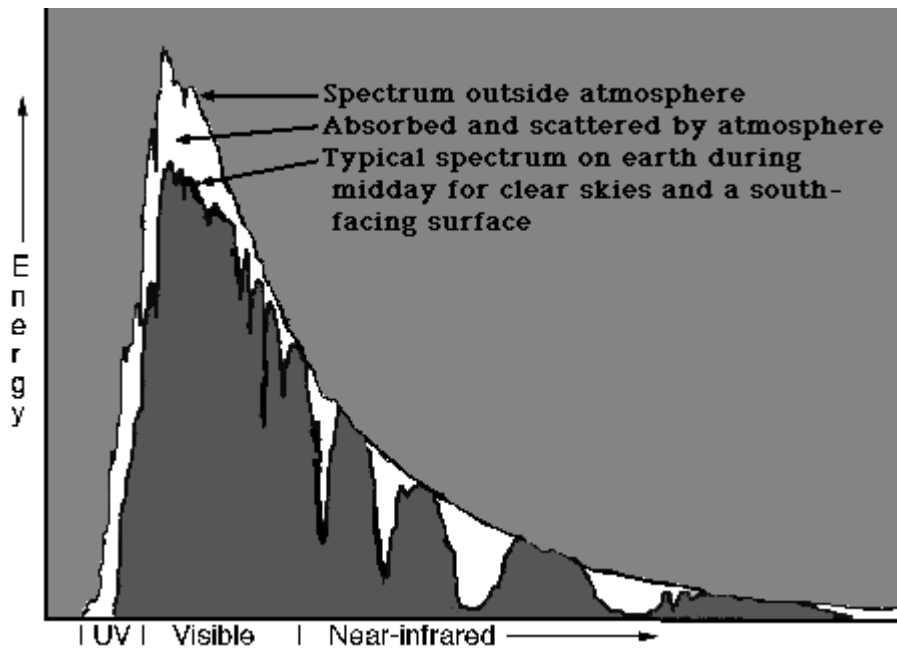

Figure G-1. Solar Spectrum at Top of Atmosphere and at Earth's Surface (courtesy of National Renewable Energy Laboratory)

As is required to maintain a constant average temperature, the earth must radiate energy at the same rate that it receives energy. The radiation emitted by the earth has a much different spectrum than the incoming solar radiation. The peak solar radiation intensity occurs at a wavelength of around 0.5 microns¹, while the radiation emitted by the earth into space has its peak intensity at a wavelength of around 10 microns¹. This difference between the spectra of incoming and outgoing radiation is the basis for the operation of flat-plate solar collectors and for the greenhouse effect¹ (see Chapter 19).

Angle Effect

The angle between the surface at some location of interest on the earth and the incident solar flux at that location depends on the latitude, the season

and the time of day. Latitude is the angle between the plane of the equator and a line from the center of the earth to a selected point on the surface (see Figure G-2). Geometrical analysis can provide a model of the angular component of radiation intensity.

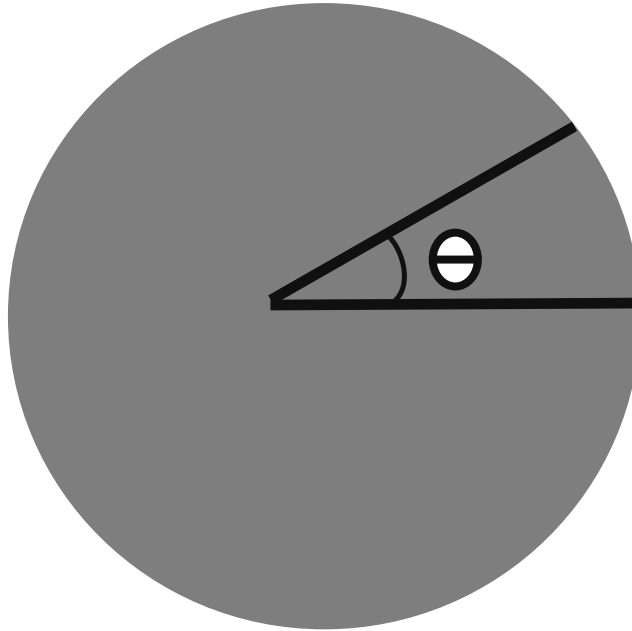

Figure G-2. Earth Latitude

Average Solar Radiation Striking the Earth's Upper Atmosphere

As a first step, let us evaluate the average solar flux impinging on the upper atmosphere. The earth, with radius, r , presents a target area of πr^2 . Therefore, the total power in the beam aimed at the earth is $I\pi r^2$, where I is the solar constant. The total earth surface is $4\pi r^2$. Therefore, the average flux impinging on the upper atmosphere above the earth is **one-fourth of the solar constant** or 342 watts per square meter, or 108 BTU per hour per square foot, or 2610 BTU per day per square foot. Specific locations experience upper atmosphere average radiation intensities that vary around this average value.

Average Solar Flux as a Function of Latitude and Season

The average global solar flux is useful for worldwide energy flow assessments, but additional information is needed to assess a specific region. It is necessary to evaluate the effects of the seasonal variation in the angle between the surface and the solar flux and the daily variation due to the earth's rotation.

The angle between the solar beam and an area of surface depends on the season and the latitude of the surface of interest. Seasonal effects arise because the earth's axis of rotation is tilted by 23.5 degrees relative to the plane of its orbit around the sun (see Figure G-3). When the North Pole is tilted away from the sun, the Southern Hemisphere receives more power per unit of surface area. The opposite effect occurs when the North Pole is tilted towards the sun.

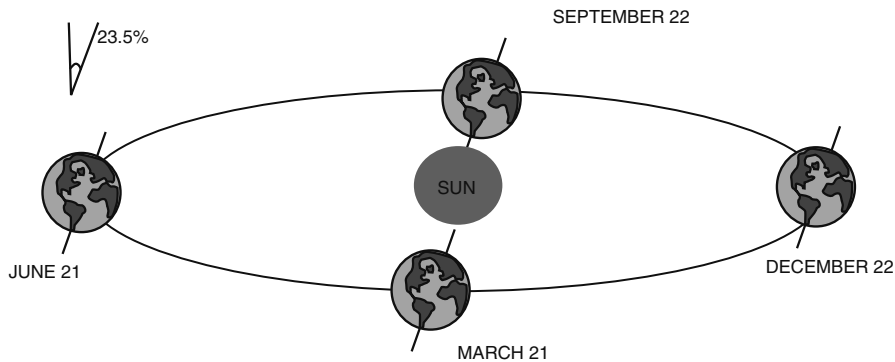

Figure G-3. Earth Orbit

A little geometry can provide the upper atmosphere energy flux as a function of latitude and season. The flux aimed at a specific surface area is depicted in Figure G-4. The angle, θ , is the angle between the solar beam and the surface of interest. The surface of interest is represented by the segment ac . The solar flux that reaches the surface passes through a projection of the surface onto a plane perpendicular to the solar beam, represented by segment ab . Consequently, the intensity of the beam aimed at the surface

(power per unit area of the surface) is $(ab/ac) \times (\text{solar constant})$. The triangles cba and ade are similar. Therefore, $\cos\theta = ab/ac = de/ea$. That is, the fraction of the solar beam intensity at the top of the atmosphere that is aimed at the surface is given by the cosine of the angle between the solar beam and the line from the earth's center and the surface of interest.

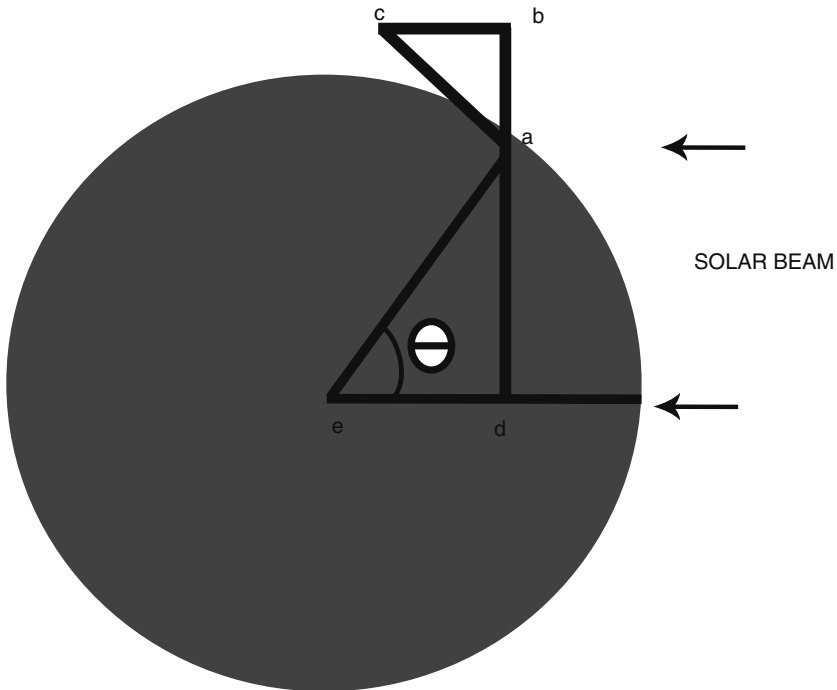

Figure G-4. Angles in Solar Incidence Analysis

To complete the analysis, determination of the seasonal variation of the angles between the solar beam and a surface of interest is also required. If the earth had no tilt relative to its plane of rotation around the sun, the angle would simply be the latitude of the surface of interest. In the northern hemisphere, the actual angle is 23.5 degrees less than the latitude in mid-summer and 23.5 degrees more than the latitude in midwinter. Since it takes half of a year to go from mid-summer to midwinter, the angle, θ , may be expressed as:

$$\theta = \text{latitude} + 23.5 - (47/182.5)t \quad (\text{G-1})$$

or:

$$\theta = \text{latitude} + 23.5 - 0.258t \quad (\text{G-2})$$

where:

t = time measured from the shortest day (days).

The shortest day occurs 10 days before January 1, so referencing the time scale to January 1 gives:

$$\theta = \text{latitude} + 23.5 - 0.258(t+10) \quad (\text{G-3})$$

The intensity of the solar beam that is aimed at a surface of interest is:

$$I(\text{surface}) = I(\text{beam}) \cos(L + 23.5 - 0.258(t+10)) \quad (\text{G-4})$$

where:

I(surface) = intensity at the surface (power per unit area of surface)

I(beam) = intensity of the beam (power per unit of cross-sectional beam area)

L = latitude of the surface of interest

Solar Radiation Intensity Variations Due To Earth's Rotation

Since the earth rotates, the average surface intensity is lower than the peak surface intensity as given by Equation G-4. This intensity is experienced by the portion of the circumferential ring that directly faces the sun. The other parts of the semi-circular illuminated part of the ring receive lower intensities because the angle of incidence decreases, reaching zero at a point 90 degrees on either side of the point facing the sun. The target area presented to the incoming solar beam of the slice of the globe with height Δh is $2r\Delta h$. The area of the whole circumferential ring is $2\pi r\Delta h$. Therefore, the average daily intensity aimed at the surface is $1/\pi$ or 0.318 times the beam intensity.

Geometrical Model Summary

The geometrical component of the average daily radiation intensities seen on the surface of the earth is described by the following equation:

$$I(\text{Surface}) = F \times (10,434 / (3.14159)) \cos(L + 23.5 - 0.258(t + 10)) \quad (\text{G-5})$$

or:

$$I(\text{surface}) = 3321.25 F \cos(L + 23.5 - 0.258(t + 10)) \quad (\text{G-6})$$

where:

- F = solar power per unit of area that escapes absorption and scattering back into space (see discussion below)
- L = latitude (in degrees)
- t = day of the year (January 1=0).

The factors in the equation are:

10,034 = the solar constant (BTU/sq ft-day)

3.14159 = π

23.5 = tilt of the earth's axis relative to the plane of motion around the sun (degrees)

0.258 = change in the angle between the solar beam and the surface of interest per day (degrees per day)

Radiation Absorption, Scattering, and Reflection

Measurements and analyses provide estimates of the fate of solar photons impinging on the earth's atmosphere. These studies are in substantial agreement. They provide energy flows for average conditions of the earth and its atmosphere. Incoming radiation has six possible fates:

1. Direct transmission to the surface and absorption by surface materials
2. Direct transmission to the surface and reflection back into space
3. Scattering by chemicals in the atmosphere with subsequent passage to and absorption by the surface
4. Scattering by chemicals in the atmosphere with subsequent transmission back out of the atmosphere into space
5. Reflection by clouds
6. Absorption by chemicals in the atmosphere

Figure G-5 shows the results of one energy budget analysis¹. Other sources with comparable results are shown in References 2 and 3. These are typical values. Values for any location are specific to that location. Figure G-5 shows that 51 percent of incident radiation is absorbed by the surface. Of this, 28 percent is direct, unscattered radiation and 23 percent is scattered, diffuse radiation. It should be noted that unscattered radiation can be focused, but scattered radiation cannot. This is important in solar power applications using solar energy concentrated with lenses or mirrors to power a heat engine.

Clouds reflect 20 percent of solar beam power according to Figure G-5. In a cloudless environment (essentially a desert environment), this power is available for surface absorption (direct and diffused) and for retransmission to space by atmospheric scattering and surface reflection. That is, 81 percent of incoming radiation is available for these processes instead of the 61 percent in the model with clouds. Local conditions would also affect the chemical composition of the atmosphere (mainly water vapor). It is likely that atmospheric absorption and scattering would be smaller in desert regions than in verdant regions, but variations due to such local effects are not included in the simple model described here.

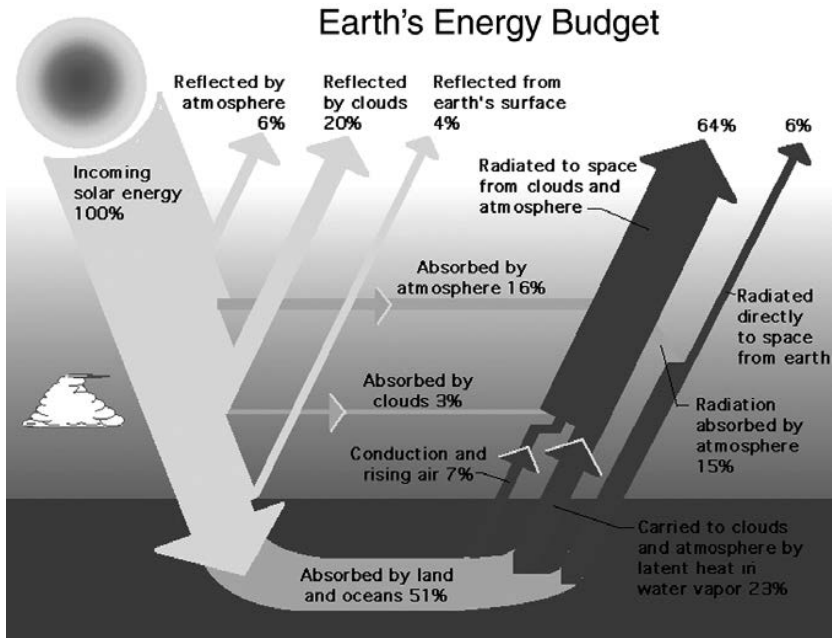

Figure G-5. Courtesy of U.S. National Aeronautics and Space Administration

Solar Absorption Analysis and Results

Solar absorption yearly average values obtained with the simple model described above were compared with measured data for selected U.S. cities reported by the National Renewable Energy Laboratory⁴. The NREL provides data for 239 U.S. locations. Results for 21 selected locations are shown in Table G-1.

It is tempting to embark on a detailed interpretation of these results, but that is not the purpose here. It is noted that the agreement between estimates for typical conditions and measurements is quite good except for desert areas, where the estimates are all lower than measured values. For desert locations (Phoenix, Albuquerque and Las Vegas), the estimates for typical conditions are 21 to 23 percent low and estimates for cloudless conditions are 4 to 7 percent low. This illustrates that desert conditions are predominantly cloudless and are better represented by a cloudless model. It should also be realized that the differences between estimated and measured values

Table G-1. Comparisons of Estimated and Measured Absorption Rates (Horizontal Surfaces)
Values in BTU per day per square foot

City	Latitude	Estimated		Measured	
		Typical	Cloudless	Typical	Cloudless
Miami, FL	25.80	1521	2028	1530	2020
Austin, TX	30.30	1465	1953	1540	1990
Phoenix, AZ	33.43	1420	1893	1810	1980
Atlanta, GA	33.65	1417	1889	1450	1890
Los Angeles, CA	33.93	1413	1884	1560	1860
Albuquerque, NM	35.05	1396	1871	1760	2020
Bakersfield, CA	35.42	1390	1853	1650	1870
Knoxville, TN	35.82	1384	1845	1340	1840
Las Vegas, NV	36.08	1380	1840	1790	1960
Greensboro, NC	36.08	1380	1840	1380	1840
Tulsa, OK	36.20	1378	1837	1420	1860
Lexington, KY	38.03	1348	1797	1280	1790
Topeka, KS	39.07	1330	1773	1360	1780
Dayton, OH	39.90	1316	1754	1250	1740
Omaha, NE	41.37	1290	1720	1330	1730
Lansing, MI	42.78	1264	1685	1190	1670
Buffalo, NY	42.93	1261	1681	1170	1690
Portland, ME	43.65	1247	1682	1230	1670
Portland, OR	45.60	1210	1613	1110	1600
Helena, MT	46.60	1190	1586	1250	1660
Bismarck, ND	46.77	1186	1581	1270	1620

are much greater on a month-by-month basis than on the yearly average basis as reported above.

It is clear that the yearly average surface radiation incidence in the continental United States ranges from 1200 to 1800 BTU per day per square foot (158 to 236 watts per square meter). In analyses whose purpose is to estimate the maximum annual yields of renewable energy sources, the average surface intensity cannot exceed 1800 BTU per day per square foot or 236 watts per square meter. Of course, summer intensities are higher and winter intensities are lower. For applications requiring unscattered (focusable) radi-

ation such as solar-powered heat engines, the yearly average surface intensity ranges from 660 to 980 BTU per day per square foot (87 to 129 watts per square meter).

References

1. <http://physicalgeography.net>
2. <http://stephenschneider.stanford.edu/Climate/Overview.html>
3. <http://marine.rutgers.edu/mrs/education/class/yuri/erb.html>
4. "Solar Radiation Data Manual for Buildings" at <http://rredc.nrel.gov/solar/pubs/bluebook/intro.html>

APPENDIX H: ORIENTATION OF SOLAR COLLECTORS

Orientation Options

Figure H-1 shows a schematic diagram of a typical fixed orientation solar collector system. Installations such as rooftop systems often dictate a fixed orientation, but solar energy absorption rates per unit area of collector surface can be increased by the use of collectors that are tilted or that track the sun during the day.

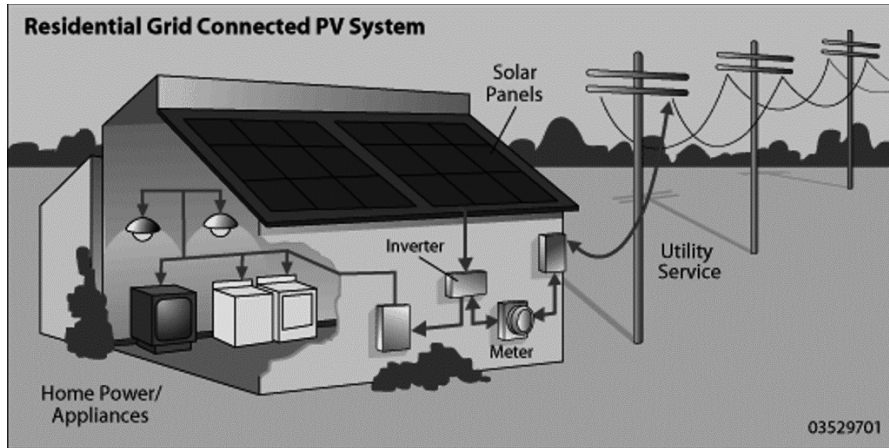

Figure H-1. A Residential Photovoltaic System (courtesy of U.S. Dept. of Energy)

The purpose of tilting a collector is to position the absorbing surface so as to be closer to perpendicular to the incident solar radiation beam than is possible with a horizontal collector. Tilted collectors may have a fixed orientation, an occasionally-adjusted orientation or a continuously-adjusted orientation. Continuously-adjusted, or tracking, collectors track the motion of the sun during its daily variation of angular position in the sky. Tracking collectors may rotate around a single axis (east-to-west) or around two axes

(east-to-west and elevation in the sky). Figures H-2 through H-4 show fixed, single axis and two axis flat-plate collector arrangements.

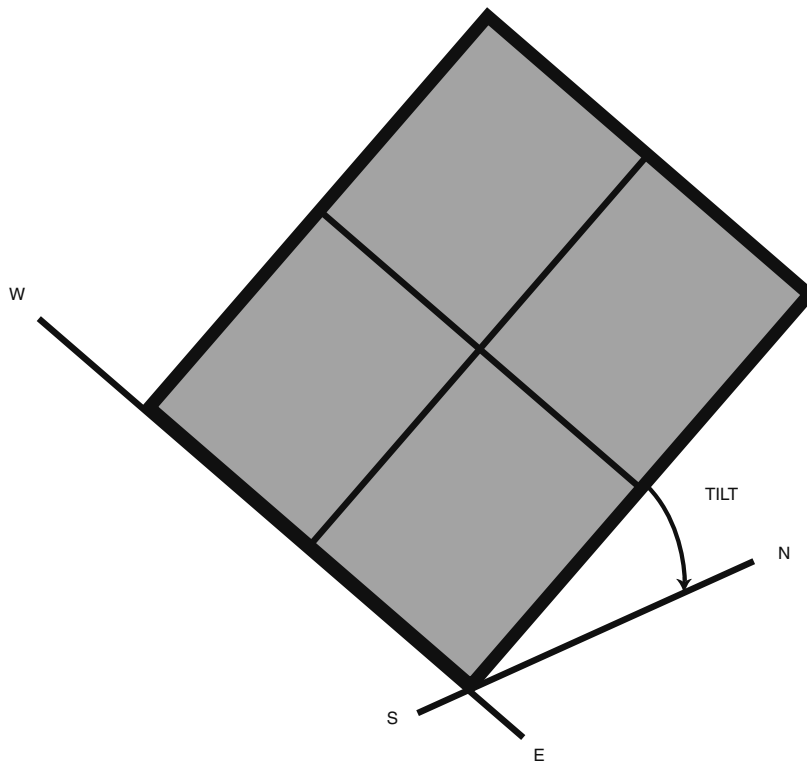

Figure H-2. A Fixed-Axis Collector

The optimum orientation of a solar collector depends on the latitude at which the collector is located, the season and the time of day. The National Renewable Energy Laboratory publishes information on solar radiation intensity for numerous U.S. locations and for fixed tilt angles, single axis tracking and dual axis tracking. (See the NREL web site¹ for “Solar Radiation Data Manual for Flat Plate and Concentrating Collectors.”)

Since the amount of local solar intensity information on the NREL web site is so large, its use is illustrated here by choosing one location: Knoxville, Tennessee. Knoxville is located at a latitude of 35.82 degrees.

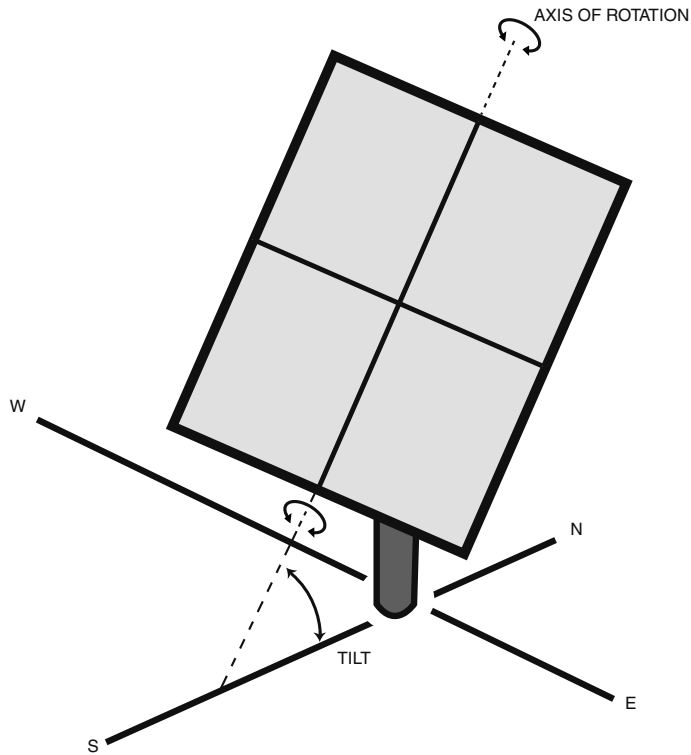

Figure H-3. A Single-Axis Collector

The NREL fixed orientation data are for a south-facing collector with orientations of zero (horizontal), latitude-15 degrees, latitude, latitude+15 degrees and 90 degrees (vertical). Data for Knoxville are shown graphically in Figure H-5. This figure shows that a fixed orientation collector can be optimized for the season of the year in which maximum performance is required. For example, an orientation of +15 is better for winter and -15 is better for summer. The figure also shows the possibility of improving fixed orientation collectors by manually re-orienting the collectors. Orienting at latitude -15 degrees or (20.82 degrees) is best in summer and latitude + 15 degrees (50.82 degrees) is best in winter. Orienting at an angle equal to latitude is a reasonable year-round compromise. Horizontal is good in summer, but poor in winter. Vertical collectors are comparable to tilted collectors in midwinter, but are much less effective in summer.

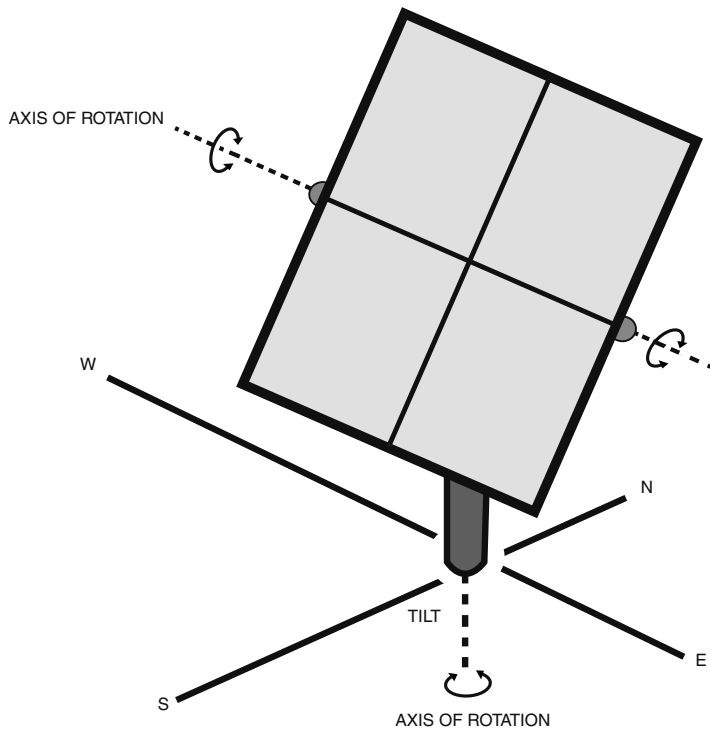

Figure H-4. A Dual-Axis Collector

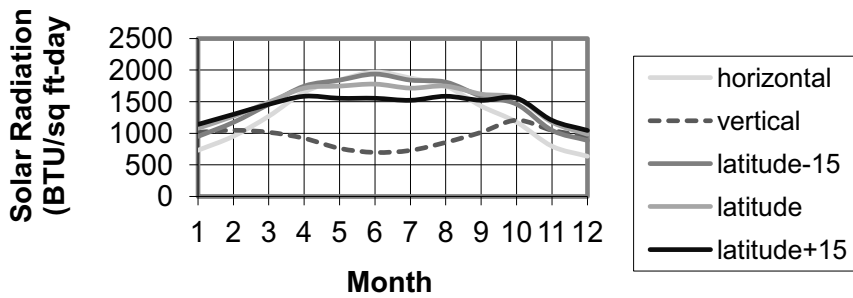

Figure H-5. Solar Energy Absorption by Fixed-Orientation Collectors in Knoxville, TN (data from National Renewable Energy Laboratory)

NREL data for a south-facing single axis collector, a dual axis collector, a horizontal fixed collector and a vertical fixed collector located in Knoxville are shown in Figure H-6. This figure shows the benefits of tracking to energy collection capability. This increase, however, comes at the expense of increased initial cost. Decisions about collector design for a particular application depend on an evaluation of capital cost versus performance. Single axis tracking is almost as good as dual axis tracking and the yearly average for either tracking system is about 28 percent better than a fixed orientation collector set at an angle equal to Knoxville's latitude.

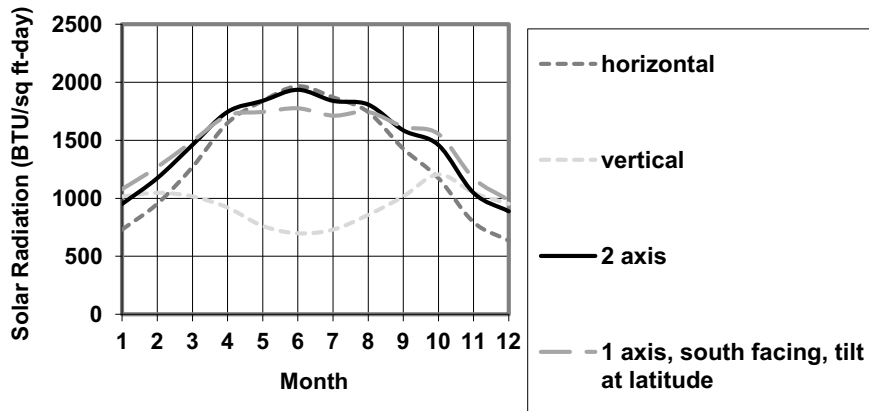

Figure H-6. Solar Energy Absorption by Fixed-Orientation and Tracking Collectors in Knoxville, TN (data from National Renewable Energy Laboratory)

While each location is unique and has its own best choices for collector orientation, the results presented above for Knoxville illustrate the trade-offs between performance and collector design features.

Daily Variations in Orientation of Tracking Collectors

The daily variations in the sun's azimuth (east-west orientation) and elevation relative to a horizontal surface determine the aiming of tracking collec-

tors. Sunrise is in the east, and sunset is in the west. The sun's elevation increases during the morning, peaks at noon and decreases in the afternoon.

A single axis tracking collector with rotation around a vertical axis would begin the day facing the sun when it rises in the morning. The collector would rotate westward until sunset.

A dual axis collector would begin the day oriented vertically and facing the sun when it rises. During the day, the collector would rotate westward around its vertical axis. The collector would increase its tilt as the morning progressed, then decrease its tilt as the afternoon progressed until it was again vertical at sunset.

Charts are available that show the sun's azimuth and elevation as a function of day of the year and time of day. (The University of Oregon provides such charts and makes them available on the Internet².) For example, Figure H-7 shows a chart for Knoxville, Tennessee. The chart shows that the sun rises at a compass bearing of 60 degrees on June 21 (the longest day of the year) and sets at 300 degrees. On December 21 (the shortest day), the sun rises at 120 degrees and sets at 240 degrees. The chart shows that the maximum elevation is about 78 degrees on June 21 and 31 degrees on December 21.

Since the azimuth and elevation are known for every location, on every day of the year and at every time of day, controllers for tracking collectors can be pre-programmed. They can also use a feedback controller to maximize solar incidence at any time.

Shadowing Effects

Daily solar radiation incidence on a collector decreases if the collector is shadowed by buildings, trees or hills. This effect is strongest in mornings and afternoons, when the sun is lower in the sky.

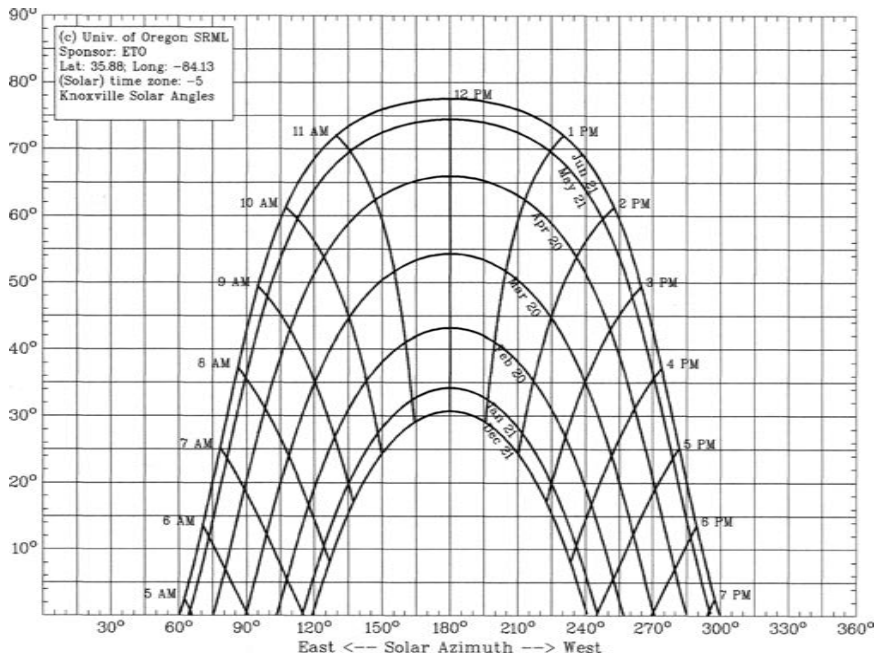

Figure H-7. The Sun's Azimuth and Elevation in Knoxville, TN (data from The University of Oregon)

References

1. http://rredc.nrel.gov/solar/old_data/nsrdb/1961-1990/redbook/mon2/state.html
2. <http://solardat.uoregon.edu/SunChartProgram.html>

APPENDIX I: PHOTOVOLTAICS

Photovoltaic devices convert light energy directly into electrical energy. Light photons can dislodge electrons from atoms in certain materials, rendering them capable of motion. With proper selection and arrangement of the materials, these electrons can be put to work as an electrical current.

Various materials can be used to make photovoltaic devices. The most common are semiconductor devices made from silicon, but other materials, including organic polymers, are also suitable for use as photovoltaic devices. The principle of operation of silicon solar cells will be described here to illustrate solar cell fundamentals.

Silicon is a very common substance. Its atomic number is 14, meaning that it has 14 protons in the nucleus and 14 orbiting electrons. The outer, or valence, shell contains four electrons. Since eight electrons are needed to fill the outer shell, four additional electrons are needed to fill the shell. Silicon acquires these electrons by sharing with adjacent silicon atoms through covalent bonds.

Incoming photons can transfer their energy to an electron in a silicon atom and kick the electron out of the valence shell. This is the photoelectric effect. The freed electron can then move through the lattice of silicon atoms.

Before the loss of an electron, the balance of positively charged protons and negatively charged electrons in each silicon atom resulted in a neutral atom. After the loss of the electron, there are 14 positive charges and only 13 negative charges, giving the atom a net positive charge. This positive charge will attract any electron in the vicinity of the atom. In essence, the initial loss of an electron creates a “hole” into which an electron can fall. If an electron leaves a nearby atom to fall into the hole, it leaves behind a hole in the atom from which it came. Thus the hole can move from atom to atom.

Consequently, kicking an electron out of a silicon atom creates two mobile charge carriers: a negative electron and a positive hole. If the substance is silicon alone, the freed electrons will eventually fall into holes and give back the energy received from the photon. Light can create free electrons in silicon, but there is no directed flow of charge carriers as is required for an electric current.

Adding certain minor impurities, called dopants, can change the properties of silicon in a way that enables the creation of a useful electric current. Consider first the addition of a substance such as phosphorous, with five electrons in its outer shell. A phosphorous atom can bond covalently with a silicon atom. Four of the phosphorous valence electrons bond covalently with a silicon atom, leaving one spare (and loosely bound) electron. This material is called an n-type material (n for negative).

Now consider a second modification of silicon. This time, add a dopant with three valence electrons, such as boron. A boron atom can bond covalently with a silicon atom, but lacks the electron needed to complete the valence shell. The modified material needs an electron to fill the outer shell and will capture an available electron for that purpose. It is called a p-type material (p for positive).

Even though n-type materials have an excess of loosely-bound electrons and p-type materials have a deficiency of electrons, each material is independently neutral. This is because nothing has been done to disturb the balance between protons and electrons in the atoms.

The electrical neutrality can be upset if n-type material and p-type materials are brought together. Electrons from the n-type material are more strongly attracted to nearby holes in the p-type material than they are attracted by the protons in their own atoms. Electrons cross the interface between the materials and fill holes in the p-type material near the interface. Since electrons are thereby added to previously neutral material, the p-type region becomes negatively charged. Similarly, the n-type material becomes positively charged because of holes created by the loss of electrons. Buildup of the negative charge on the p-type material near the interface inhibits further

passage of electrons from the n-type material and inhibits the further creation of holes in the n-type material.

This barrier prevents further electron flow from n-type material to p-type material, but allows electron flow from the p-type material to the n-type material. When an electron leaves the p-type material, it leaves behind a hole. The hole cannot accompany the electron into the n-type material because of the positive charge on the n-type material at the interface. The p-n junction is a diode, a configuration that allows current flow in one direction and prevents current flow in the other direction.

If a photon creates an electron-hole pair far from the interface, it is likely that the electron will recombine with a hole and the hole will recombine with an electron. However, if an electron-hole pair is born near the interface, the electron and the hole will be forced to move in opposite directions.

Consider an electron-hole pair created in n-type material near the interface. Since the n-type region is positive, the hole will be repulsed and will move into the negatively charged p-type region, thereby adding positive charge to the p region. The electron left behind will add negative charge to the n region. Similarly, the creation of an electron-hole pair in the p region will result in the electron being repulsed and moving into the positively charged n region, and the hole left behind will add positive charge to the n region. Every electron-hole pair creation near the interface adds positive charge to the n region and negative charge to the p region. If an external conductor connects these regions, electrons will flow through the conductor from the p region to the holes in the n region. This electron flow is an electric current.

APPENDIX J: RADIATION ABSORPTION PHYSICS

Radiation Emission

All substances whose temperatures are above absolute zero emit electromagnetic radiation. The radiation has a dependence of emissive power on wavelength given by Planck's Radiation Law:

$$E = C1/(\lambda^5(e^{C2/(\lambda T)}-1)) \quad (J-1)$$

where:

E = emissive power of a black body (watts/m²-micron)

T = absolute temperature (kelvins)

λ = wavelength (microns)

C1 = 3.74x10⁸

C2 = 1.44x10⁴

Note that emissive power is expressed in units of energy flux (watts/m²) per unit of wavelength.

Planck's Law applies for a so-called "black body," a theoretical body that is a perfect emitter and perfect absorber of electromagnetic radiation. Radiation impinging on a black body experiences absorption but no reflection or transmission. No actual substance can absorb or emit as much radiation as a black body at the same temperature, but many are quite close.

Figures J-1 and J-2 show the black body emission spectra for the sun (average surface temperature = 5800 kelvins) and the earth (average surface temperature = 288 kelvins or 15°C or 59°F).

The peak in a radiation spectrum, L(peak), is given by Wien's Law:

$$L(\text{peak}) = 2898/T \quad (J-2)$$

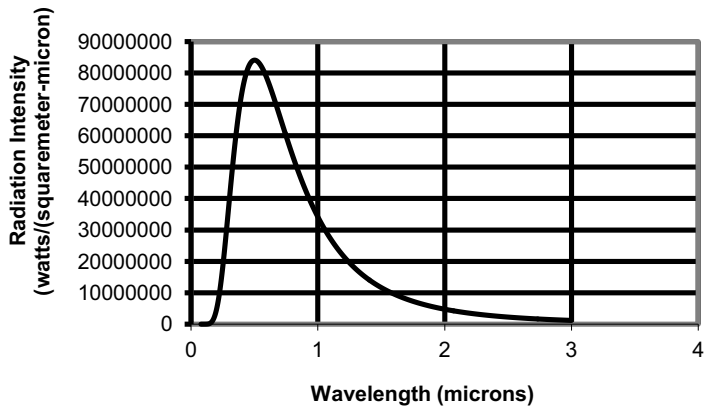

Figure J-1. The Solar Spectrum

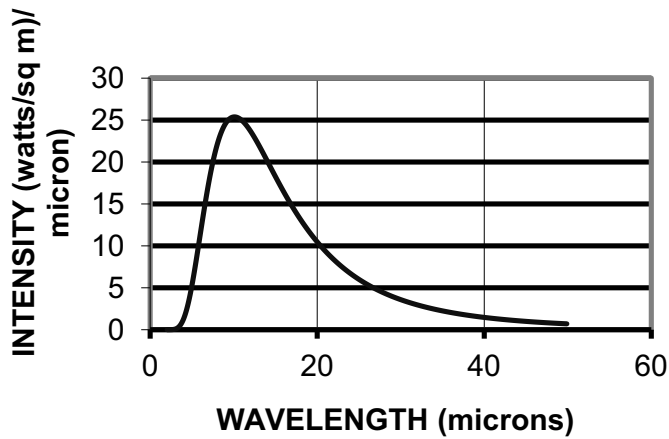

Figure J-2. The Earth's Emission Spectrum

The sun's spectrum peaks at 0.5 microns, and the earth's spectrum peaks at 10.1 microns.

The total energy emitted at all wavelengths is obtained by integrating the Planck's Law formula over all wavelengths. The result, called the Stephan-Boltzmann Law, is:

$$E_t = 5.67 \times 10^{-8} AT^4 \quad (J-3)$$

where:

E_t = power emitted at all wavelengths (watts)

A = emitter surface area (m^2)

T = temperature (kelvins)

For example, the predicted solar energy flux (watts per square meter) at the surface of the sun is:

$$\begin{aligned} E_t/A &= 5.67 \times 10^{-8} \times (5.8 \times 10^3)^4 \\ &= 6.42 \times 10^7 \text{ watts per square meter} \\ &= 64.2 \text{ megawatts per square meter} \end{aligned}$$

Emitting 64.2 megawatts from a square meter of surface is **very intense** power delivery.

Radiation Absorption

Radiation is absorbed by the transfer of photon energy to electrons in an absorbing substance. Substances have absorption spectra characterized by absorption “lines” at specific wavelengths that are unique to the substance. The lines are smeared somewhat rather than sharp spikes. The smearing is due to motion of the electrons, a function of temperature and pressure.

Of course, an absorber substance must also emit radiation as long as its temperature is above absolute zero. Any heating due to photon absorption must be balanced by subsequent radiation from the absorber. This radiation will be called *re-emitted radiation*, but it is important to note that the radiation is not simply the release of the same photons that were absorbed. The re-emitted radiation consists of photons with a spectrum determined by the absorber’s temperature. For example, absorption of photons of a single wavelength will give rise to photons with a spectrum of wavelengths determined by the temperature of the absorber. Furthermore, the photons emit-

ted from the absorber emerge in all directions. Consequently, half of the photons emitted from the absorber are directed back towards the source of the absorbed photons.

Photon interactions with matter can be viewed as the passage of photon packets through a cloud of discrete absorber sites, where some of the photons are absorbed. The remaining fraction of unabsorbed photons decreases exponentially with distance through the absorber. One may speak of an “extinction distance” as the distance through an absorber required to absorb essentially all (say 99 or 99.9 percent) of the incident photons.

Radiation Energy Balances

Bodies (such as the earth) receive incident radiation and emit radiation. To achieve and maintain a constant temperature, the emitted radiation must equal the absorbed radiation. For example, the earth receives radiation from the sun. In order to have a constant average temperature, the earth’s temperature must be such that the radiation emitted to outer space equals the radiation from the sun.

Absorption Windows

Absorption windows are ranges of wavelengths over which absorption is small. Photons within this range of wavelengths will pass through with little or no absorption. Absorption windows occur at those wavelengths where the photon energy does not equal allowed electron energy transitions (see Section 2.9.1).

The effective windows for a mixture of gases are located at wavelengths where all of the windows for the constituent gases coincide.

Gas Concentration and Absorption

One of the arguments used by those who dispute global warming is the claim that the atmospheric absorption of photons emitted by the earth in carbon dioxide has reached saturation. That is, they say that the absorptions in atmospheric carbon dioxide have already reached their maximum and further increases in concentration would have no effect. However, the consensus among climate experts is that the saturation argument is invalid.

The arguments for and against the saturation argument will not be presented here, but it will be shown that the issue involves more than just the fate of photons emitted from the earth. It is important to recognize that a photon's energy does not disappear when the photon is absorbed. Instead, it heats the absorber which, in turn, emits photons with a spectrum determined by the absorber's temperature. Thus absorption does not stop energy flow.

If an atmospheric gas absorbs photons of a certain wavelength to extinction before they have traveled very far through the atmosphere, then increasing the concentration of the gas does not change the rate of absorption of **incident** photons. However, increasing the gas concentration will decrease the depth in the gas at which the extinction of incident photons occurs. The absorptions of incident photons will heat the absorber and result in the production of re-emitted photons that emerge in all directions. If they are to escape the atmosphere into outer space, the re-emitted photons released in the outward direction must pass through a greater thickness of absorber than they would with a lower absorber concentration. Of course, the outward-directed re-emitted photons may be absorbed before exiting the atmosphere, and these absorptions will heat the absorber and produce new re-emitted photons that emerge in all directions. Consequently, absorption to extinction of incident photons creates a cascade of sorts, and the re-emitted photons may escape (and carry energy) into outer space even though the incident photons do not.

So the energy loss to outer space depends on absorptions of re-emitted photons as well as of incident photons. It is wrong to say that increases in the

concentration of a gas that absorbs to extinction have no effect on energy loss to outer space. Increases in concentration cause re-emitted photons to face longer routes through the gas and greater probability of absorption rather than transmission and escape into outer space, but some re-emitted photons can escape when incident photons are absorbed to extinction.

Since re-emitted photons have a spectrum determined by the temperature of the absorber, they experience absorption only in that portion of their spectrum where they encounter strongly absorbing gases. Thus the re-emitted photons have a different probability of absorption in atmospheric gases than incident photons, and this further affects the energy loss to outer space.

APPENDIX K: AIR CONDITIONERS AND HEAT PUMPS

Introduction

There are five types of air conditioning systems: vapor compression, vapor absorption, evaporative, thermoelectric and gas depressurization. Vapor compression systems are the most common. They are widely used in home air conditioners and refrigerators and in commercial and industrial applications. Vapor compression, vapor absorption and evaporative systems are all phase-change systems (they use the evaporation of a liquid to absorb heat). Thermoelectric systems use a process called Peltier cooling. Gas depressurization systems are based on the compression and subsequent release of gas from a high-pressure reservoir. Details of the principles of operation of these systems appear below.

Heat pumps provide heating as well as cooling by a phase-change process. They exploit the condensation of a vapor to release heat.

Air conditioners and heat pumps based on vapor compression and vapor absorption transfer heat from a colder region to a hotter region. This is opposite to the direction of spontaneous heat flow. This cold-to-hot heat flow is accomplished by the use of external sources of mechanical or thermal energy.

A summary of key features of phase-change cooling systems appears in Table K-1 (a repeat of Table 15-3, included here for the reader's convenience):

Table K-1. Features of Phase-Change Coolers

System Type	Open or Closed	Fluid	Energy Supply	Relative Complexity
Compression	C	single refrigerant	mechanical	intermediate
Absorption (two-component)	C	refrigerant, absorber	heat, low power pump	intermediate
Absorption (three-component)	C	refrigerant, absorber, inert gas	heat	high
Evaporative	O	water	low power fan	low

Cooling Systems

Vapor Compression Systems

A vapor compression cooling system is a closed cycle system, meaning that all vapors and liquids are contained in the system and they recycle through the system to accomplish cooling. In vapor compression systems, evaporation of liquid refrigerant absorbs heat from the space that is to be cooled. The subsystem where this occurs is called the evaporator. In order to repeat this process, the refrigerant must be returned to the liquid state. A compressor uses mechanical energy to raise the pressure of the refrigerant. This process also raises the refrigerant's temperature. The hot refrigerant is cooled and condensed by transferring heat to the surroundings in a condenser. The cooled liquid refrigerant is then ready to re-enter the evaporator and begin repeating the process. Energy flows into the system from the compressor and the evaporator and leaves the system through the condenser.

A vapor compression air conditioner is shown in Figure K-1.

Vapor Absorption Systems

Vapor absorption air conditioners use externally-supplied heat as the energy source. It may be counter-intuitive for heat to be used to provide cooling, but these systems work quite well. The heat source may be fossil fuel, electricity or solar energy.

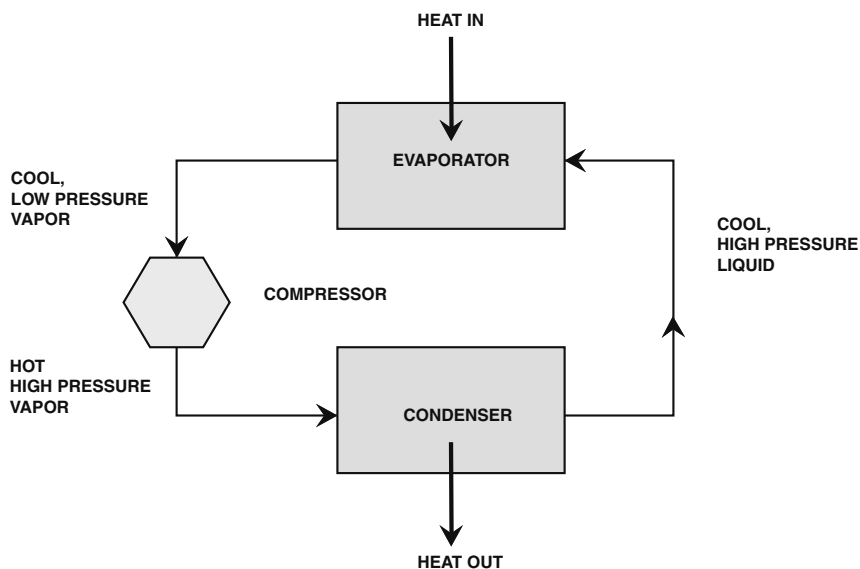

Figure K-1. Vapor Compression Air Conditioner or Heat Pump

There are two main types of vapor absorption systems. A two-component system uses a refrigerant and an absorber fluid. A three-component system uses a refrigerant, an absorber fluid and an inert gas. In both types, energy is removed from the cooled space by evaporation of the refrigerant, and the vapor exiting the evaporator is absorbed into the absorber fluid. The subsystem where this occurs is called the absorber. The two vapor absorption types differ in the way that they process the refrigerant-absorber mixture from the absorber. The processing provides refrigerant in the proper state for re-entry into the evaporator, where evaporation and cooling occur.

A two-component system uses a pump to raise the temperature and pressure of the refrigerant-absorber liquid mixture. Heat is then applied to boil off the refrigerant from the mixture. The high-pressure, heated vapor then goes to a condenser, where the refrigerant is cooled to become a pressurized liquid. This pressurized liquid is then ready for re-introduction into the evaporator. The two-component system requires some mechanical energy to drive the pump, but this is much less than the energy required to drive a compressor in a vapor compression system.

Common two-component vapor absorption systems are those that use ammonia as a refrigerant and water as an absorber, or use water as a refrigerant and a lithium bromide solution as an absorber. An ammonia-based two-component vapor absorption air conditioner is shown in Figure K-2.

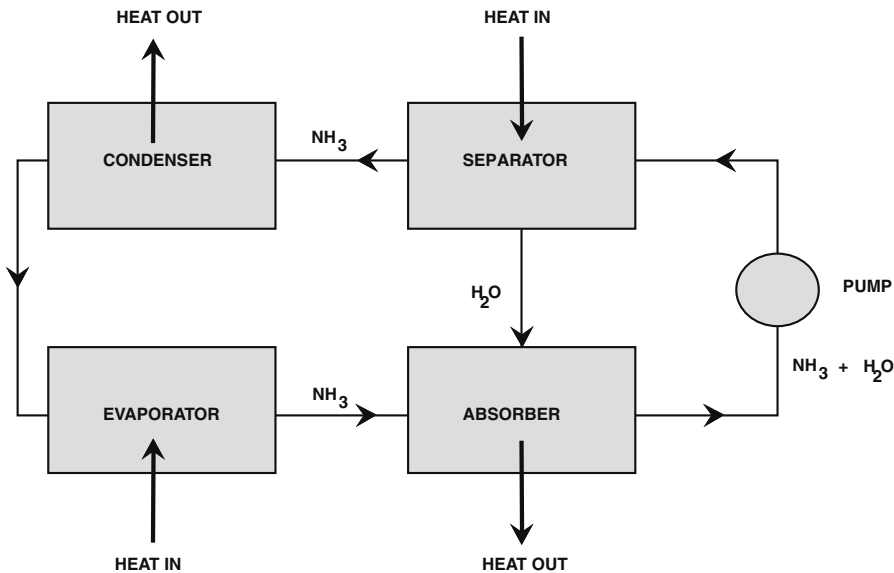

Figure K-2. A Two-Component Vapor Absorption System

Before starting a description of the three-component vapor absorption cooling process, it is helpful to explain Dalton's Law of Partial Pressures. This law is the basis for the unique feature of the three-component vapor absorption cooling system: it does not require a pump. Dalton's Law states that the total pressure is the sum of the partial pressures of the vapors present. In a mixture of vapors, the partial pressure of any vapor is reduced by the presence of the other vapor or vapors.

The vapor pressure of a liquid is a measure of the tendency of the liquid to evaporate. A liquid boils when its vapor pressure is equal to its partial pressure in the surrounding environment.

A typical three-component vapor absorption cooler contains ammonia, water and hydrogen. A convenient place to start in describing the cycle is the evaporator, where cool liquid ammonia is present. At this point, hydrogen gas is introduced. The hydrogen serves to reduce the partial pressure of the ammonia. Boiling ensues when the ammonia vapor pressure equals the ammonia partial pressure. The ammonia evaporates, thereby drawing heat from the surroundings.

The rest of the cycle serves to return the ammonia to the liquid state. This begins with mixing the ammonia-hydrogen mixture with water in the absorber. The ammonia dissolves in the water, and the hydrogen does not. (The hydrogen is recycled to again perform its function of reducing the ammonia partial pressure in the evaporator.) The ammonia-water mixture is then heated by an external heat source, causing ammonia vapor to boil off. (Thus the role of the heat source is to separate the ammonia from the water in which it is dissolved.) The subsystem where the ammonia is separated from the water is called the generator. The resulting ammonia vapor is cooled in a condenser by transferring heat to the surroundings. The cool liquid ammonia is the condition existing at the start of the cycle. Note that no mechanical energy is required. A three-component vapor absorption air conditioner is shown in Figure K-3.

Interest in vapor absorption systems is increasing because of the reduction or elimination of the need for grid electricity and the possibility of using solar energy as the heat source.

Evaporative Systems

Of course, vapor compression and vapor absorption systems rely on the evaporation of a refrigerant to achieve cooling, but the term evaporative cooling usually refers to open cycle coolers that cool by evaporating water with ambient air. The systems for residential coolers are quite simple: a fan that blows air over a wet wick. The chilled air may be blown directly into a residence (a direct type cooler), or it may be used to cool a second fluid that subsequently is used to extract heat from the living space (an indirect type cooler). An evaporative air conditioner is shown in Figure K-4.

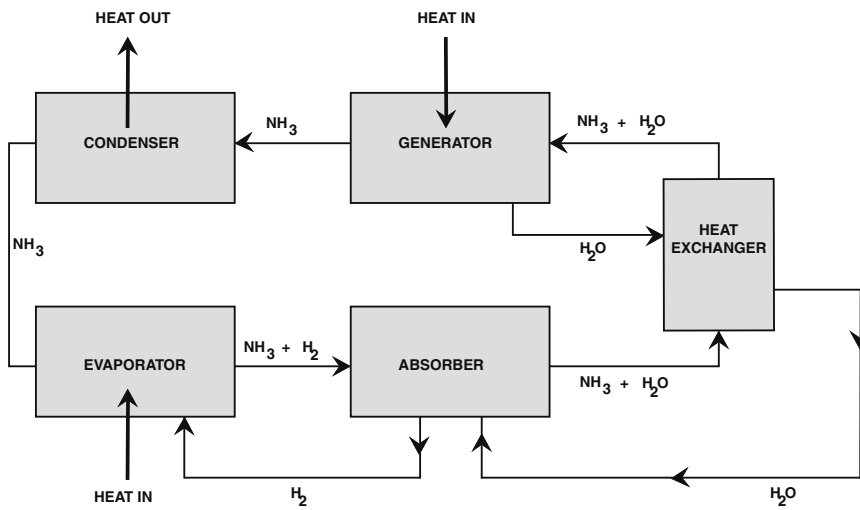

Figure K-3. A Three-Component Vapor Absorption System

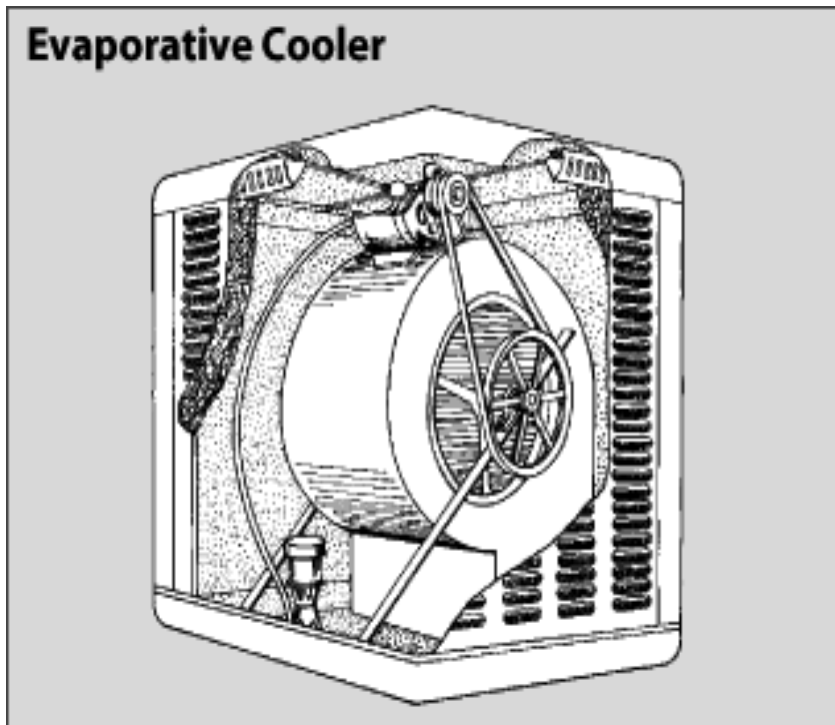

Figure K-4. An Evaporative Cooler (courtesy of U.S. Dept. of Energy)

Evaporative coolers are effective in regions where the air is hot and dry, such as the southwestern United States. Advantages of these coolers are low initial cost and low operating costs. Disadvantages are water consumption (typically 3.3 to 10.5 gallons per hour for a home unit) and elevated indoor humidity for direct type coolers.

Evaporative cooling is also used in large-scale industrial applications. Cooling towers use water evaporation to provide cooling in many electric-power and manufacturing plants. These systems transfer waste heat to the air rather than to a river or body of water. Concerns about heating aquatic environments often dictate the use of cooling towers.

Thermoelectric Systems

Thermoelectricity involves using a temperature difference to create an electric voltage or using an electric current to create a temperature difference. Thermoelectric devices can be used to measure temperature, to produce electrical energy or to provide heating and cooling. Thermoelectric systems are very simple, involving only two different conductors with dissimilar thermoelectric properties.

If two conductors made of different materials are joined at both ends, and one end is at a higher temperature than the other, a voltage will be produced, and a current will flow (see Figure K-5). This configuration is a thermoelectric power generator. Conversely, if a current is passed through a circuit in which the dissimilar materials are joined at both ends, one junction will cool, and the other will warm (see Figure K-6). This configuration is a thermoelectric heater/cooler.

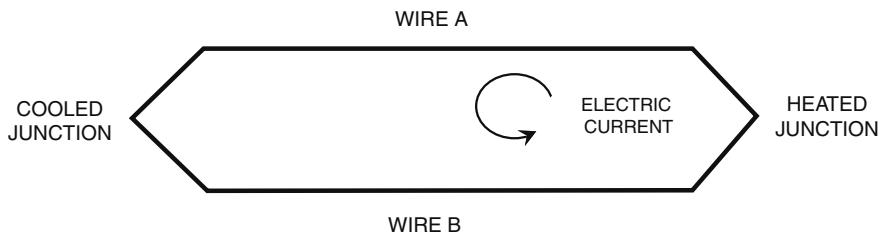

Figure K-5. A Thermoelectric Generator

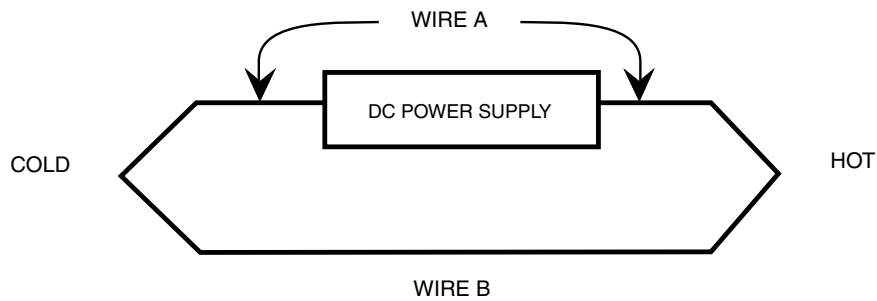

Figure K-6. A Thermoelectric Heater/Cooler

If the dissimilar wires are joined at only one end and a temperature differential exists between the two ends, a voltage will appear across the conductors. Open circuit conditions are adequately approximated if the wires are connected to a voltage measuring system with high input impedance. This voltage increases as the temperature difference between the open end and the closed end increases (see Figure K-7). This configuration is a thermocouple, the most common instrument used in industry for measuring temperature.

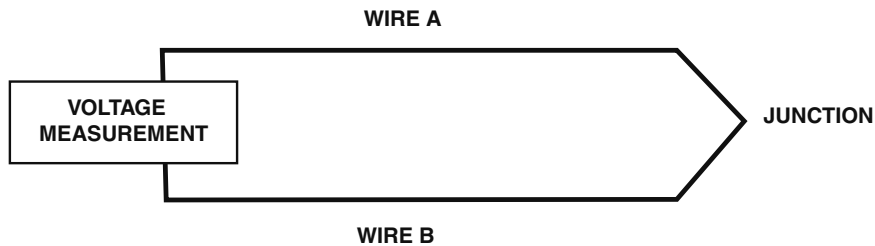

Figure K-7. A Thermocouple

Thermoelectric heating and cooling systems are useful in small-scale applications such as temperature control in instrumentation and in beverage heaters and coolers. They are not used for large cooling systems such as in residence air conditioning applications.

Gas Depressurization Systems

Pressurizing a gas raises the temperature of the gas, and depressurizing a gas cools it. Cooling can be achieved by releasing stored pressurized gas after it has been cooled by heat transfer to the environment. This is an inefficient cooling method, but it is sometimes used in special applications such as aircraft air conditioning systems. (See Figure K-8.)

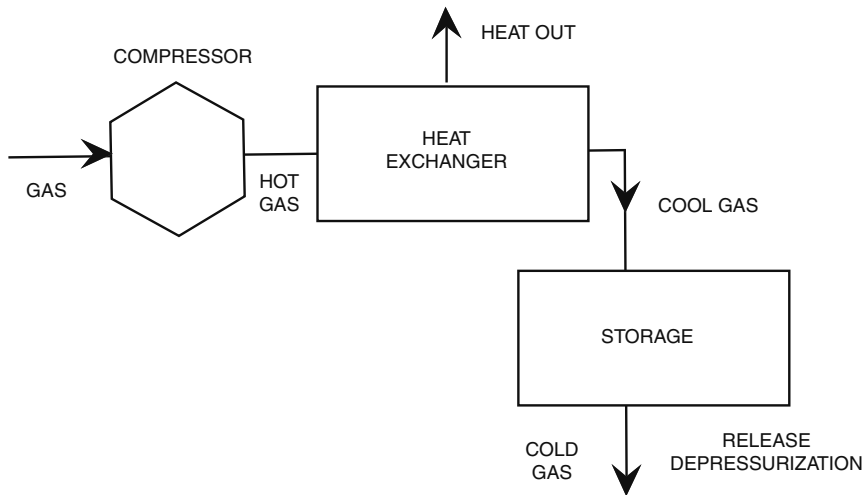

Figure K-8. A Gas Decompression Cooler

Heat Pumps

We have seen that closed-cycle refrigeration systems operate by collecting heat from a cooler region in an evaporator and dumping that heat into a warmer region in a condenser. For an air conditioning application, the space of interest is the space to be cooled by evaporation in the evaporator. Conversely, heat can be transferred to a warmer space by transferring heat from the condenser. Basically, heating with a heat pump is simply the use of an air conditioner with the transfer to the space of interest from the condenser rather than the evaporator.

Performance Measures

Air conditioner cooling capacity is usually quantified by “tons of capacity.” This metric is equal to 12,000 BTU per hour. The term arose in early refrigeration applications and is the amount of heat energy that must be removed from a ton of water at 32°F in one day to produce ice.

The performance of a vapor compression refrigeration system may be quantified by the “Coefficient of Performance” or COP, which is defined as follows:

$$\text{COP} = (\text{energy removed from cooled space})/(\text{energy supplied to the compressor}).$$

The COP can be greater than unity, indicating that more energy can be removed from the cooled space than the mechanical energy supplied by the compressor.

The maximum theoretical COP is determined by the temperatures, T_{cool} of the cooled space and the temperature T_{hot} of the space that receives heat from the condenser (this space is called the *heat sink*). The temperatures must be in absolute temperature units (degrees Rankine or kelvins). The maximum COP is given by:

$$\text{COP}_{\text{max}} = T_{\text{cool}}/(T_{\text{hot}} - T_{\text{cool}})$$

Example K.1

Consider a cooler with $T_{\text{hot}} = 90^\circ\text{F}$ or $90 + 460 = 550^\circ\text{R}$ and $T_{\text{cool}} = 60^\circ\text{F}$ or $60 + 460 = 520^\circ\text{R}$. In this case the maximum theoretical Coefficient of Performance is:

$$\text{COP}_{\text{max}} = 520/(550 - 520) = 17.3.$$

Actual values of the COP in real systems are less than COP_{max} because of energy losses within the process. Typical values of the COP achieved in actual air conditioner operation are in the range of 3 to 5. Nevertheless, the

formula for COP_{max} reveals some important aspects of air conditioner performance. For example, the possibility of achieving some value of T_{cool} is diminished as T_{hot} increases. Since cooling is usually needed when the weather is hot, using hot ambient air as the heat sink limits cooling capability. However, other heat sink options besides ambient air are available, though at some cost. Using subsurface earth as the heat sink, where temperatures are generally lower than ambient air temperature in summer, increases the COP. These systems are called ground-effect or geothermal systems.

Heat pump effectiveness may be characterized by a Coefficient of Performance in the same manner as for air conditioners. The COP for heating with heat pumps is given by:

$$COP = (\text{energy added to the heated space})/(\text{energy supplied to the compressor}).$$

The maximum theoretical COP for heating is given by:

$$COP_{max} = T_{hot}/(T_{hot}-T_{cool})$$

The possibility of achieving some value of T_{hot} is diminished as T_{cool} decreases. Since heating is usually needed when the weather is cool, using cool ambient air as the heat source limits heating capability. Heat pumps are not effective for heating in cold climates. As with air conditioners, heating performance may be improved by supplying heat to the evaporator from subsurface regions, where temperatures are higher than ambient air temperature in winter.

The U.S. Department of Energy has developed a measure of air conditioner efficiency called the Energy Efficiency Ratio (EER). The EER rating is the ratio of the BTUs removed under specified ambient conditions to the watt-hours of electrical energy used to produce the cooling. Another measure, the Seasonal Energy Efficiency Ratio, or SEER, addresses the performance on a typical day rather than for a specific ambient air condition. The SEER rating is the ratio of BTUs removed on a “typical” day with an air condi-

tioner divided by the watt-hours of electrical energy used to produce the cooling.

The Department of Energy mandates minimum SEER ratings for new equipment. SEER ratings are useful to the consumer in comparing the performance of different equipment options. Most current air conditioners and heat pumps have SEER ratings in the low teens. New systems with higher efficiency have SEER ratings as high as the low twenties.

A performance measure for heating with a heat pump is called the Heating Seasonal Performance Factor (HSPF). HSPF is the ratio of heat output (in BTUs) to watt-hours of electricity used. HSPF values of 8 or greater are considered to be indicative of efficient performance. The HSPF is less well known by consumers than SEER ratings, and it is therefore less frequently considered in making equipment selections.

The Department of Energy and the Environmental Protection Agency identify energy-efficient systems by granting them an ENERGY STAR rating. ENERGY STAR ratings are assigned to appliances, heating and cooling systems, electronics lighting, and buildings. These ratings serve to indicate systems that use energy efficiently.

APPENDIX L: TRIGLYCERIDES

Vegetable oils and animal fats contain triglycerides. Triglycerides are members of a family of chemicals called esters. Esters are compounds that are composed of linked alcohols and fatty acids. Fatty acids are chains of carbon atoms (usually 16 to 18 carbon atoms) with hydrogen atoms attached along the chain and with a carboxyl group at one end. A carboxyl group is a section containing one carbon atom, one oxygen atom and one hydrogen atom. A fatty acid molecule is shown symbolically in Figure L-1. The saw tooth portion is a hydrocarbon chain.

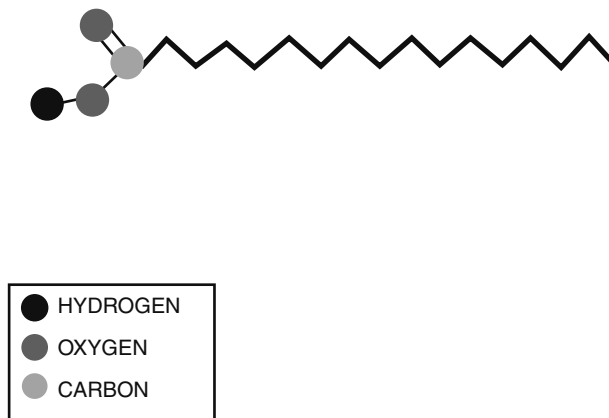

Figure L-1. A Fatty Acid Molecule

Triglycerides may be modified to improve their properties for use as a liquid fuel by basic transesterification, acid transesterification and hydroprocessing.

The alcohol spine in the triglyceride ester is glycerol. Glycerol is an alcohol with three carbon atoms. It provides three sites for linking with fatty acids. The structure of the glycerol molecule is shown symbolically in Figure L-2. The structure of the triglyceride molecule is shown symbolically in Figure L-3.

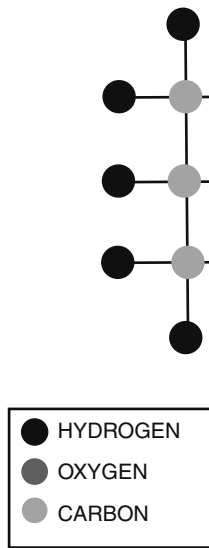

Figure L-2. A Glycerol Molecule

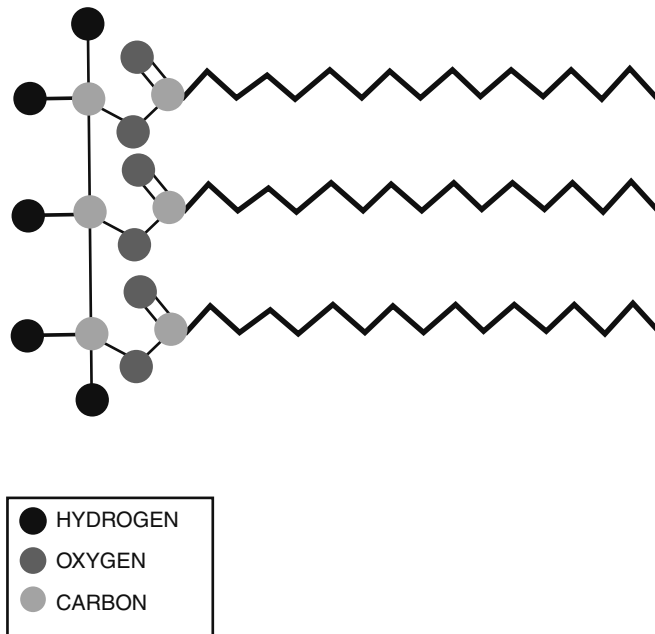

Figure L-3. A Triglyceride Molecule

The three fatty acids in a triglyceride may be the same or different. An important feature of the fatty acids is whether they are saturated or unsaturated. Saturated fatty acids have the maximum number of hydrogen atoms per carbon atom that is chemically possible. Unsaturated fatty acids have fewer hydrogen atoms per carbon atom than is chemically possible. Most animal fats are saturated triglycerides and most vegetable oils are unsaturated. Saturated triglycerides are solid at room temperature, and unsaturated triglycerides are liquid.

In the transesterification processes, the glycerol spine is replaced by another alcohol that connects with only a single fatty acid, rather than three. Methanol and ethanol are capable of the transesterification of triglycerides. In the basic transesterification process, the glycerol-fatty acid bond is broken with a strong base, usually sodium hydroxide (lye) or potassium hydroxide. This is done in the presence of methanol or ethanol. The fatty acid chains link with the methanol or ethanol to form single-chain esters, either a methyl fatty acid ester or an ethyl fatty acid ester. The process also yields glycerol. The esters are separated from the glycerol. They are suitable for use as a liquid fuel.

The acid transesterification process is similar, but acid is used to break the glycerol-fatty acid link.

Hydroprocessing involves breaking the glycerol-fatty acid bond catalytically or thermally, removing the oxygen from the resulting fatty acids and hydrogenating to obtain saturated hydrocarbon chains. Basically, this approach consists of deconstructing the triglyceride molecules and constructing hydrocarbons from the contained carbon and hydrogen.

APPENDIX M: BIOETHANOL

Ethanol is an important biofuel. It is a clear liquid that readily mixes with water. Ethanol is more volatile than water (it has a boiling point of 78.4°C, or 173.1°F). The low heating value (LHV) of ethanol is 11,500 BTU per pound or 75,700 BTU per gallon, and the high heating value (HHV) is 12,800 BTU per pound or 84,000 BTU per gallon. The chemical formula for ethanol is C₂H₅OH. Combustion yields water and carbon dioxide as follows:

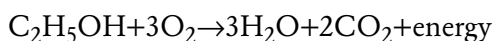

The molecular structure of ethanol is shown symbolically in Figure M-1.

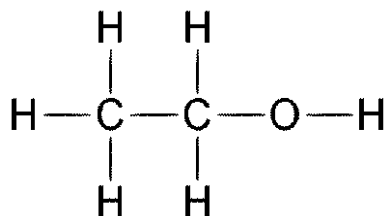

Figure M-1. An Ethanol Molecule

Ethanol is an excellent solvent. It reacts with certain rubbers and plastics, making it necessary to avoid these materials in ethanol production, storage, transport and use in engines. Because ethanol also mixes readily with water, fuel ethanol must be isolated from water in order to avoid degrading its usefulness as a fuel.

Ethanol from Carbohydrates

Ethanol is a renewable liquid fuel that is most often made from carbohydrates (plant materials that are composed entirely of three elements: carbon, hydrogen and oxygen). They include sugar, starch, cellulose and hemicellulose. Carbohydrates all consist of linkages of simple sugars (monosaccharides). The number of sugar units in other carbohydrates range from two (in sucrose, common table sugar, a disaccharide) to over 1,000 (in cellulose, a polysaccharide).

It should be noted that ethanol production from carbohydrates can capture energy contained in stalks, stems and leaves (residues from traditional farming) as well as from seeds and fruit. The gathering of farm residues requires harvesting efforts, but no commitment of new, dedicated farmland.

Biochemical production of ethanol from carbohydrates involves three steps:

1. Transforming the naturally occurring carbohydrates into monosaccharides. This process is called hydrolysis.
2. Transforming the monosaccharides into ethanol and CO₂. This process is called fermentation.
3. Separation of the ethanol from the water remaining from the previous steps. Separation requires two processes: distillation, capable of producing a maximum ethanol concentration of 96 percent; and subsequent dewatering with water-absorbing material to obtain 100 percent ethanol.

Complex biochemical processes play a crucial role in transforming carbohydrates into liquid fuels. Two of the terms needed to describe the production of ethanol from plants are as follows:

- **Enzyme:** A specialized protein molecule that enables or hastens a biochemical reaction without being consumed in the process. In chemical terms, an enzyme is a form of catalyst.
- **Fermentation:** The enzyme-controlled process of transforming an organic material into another organic material. Enzymatic conversion of sugars to ethanol is an example of fermentation.

Monosaccharides have two hydrogen atoms and one oxygen atom per carbon atom. Six carbon sugars (called hexoses) and five carbon sugars (called pentoses) have the following chemical formulas:

Hexoses: $C_6H_{12}O_6$

Pentoses: $C_5H_{10}O_5$.

Fermentation of monosaccharides to produce ethanol is represented by the following chemical reactions:

Hexoses: $C_6H_{12}O_6 \rightarrow 2C_2H_5OH + 2CO_2$

Pentoses: $3C_5H_{10}O_5 \rightarrow 5C_2H_5OH + 5CO_2$

Carbon dioxide is produced in the fermentation of both.

When ethanol oxidizes, it releases quantities of carbon dioxide and water that are exactly equal to the quantities of carbon dioxide and water initially consumed in photosynthesis by the plant. The energy released also is the same as the solar energy initially captured during photosynthesis.

Enzymes play a crucial role in ethanol production from biomass. They are used both in hydrolyzing disaccharides and polysaccharides into fermentable monosaccharides and in the conversion of the monosaccharides into ethanol. All animals, green plants, fungi and bacteria produce enzymes. They are very specific proteins that serve as highly selective facilitators for certain biochemical reactions. They enable or hasten reactions, but are not

consumed in the process. Enzymes are thought of as molecules that are shaped so as to fit only with a specific host molecule. After the fit occurs, the host molecule undergoes some specific reaction, then releases the enzyme to do its work somewhere else.

Even though enzymes are not consumed in the reactions that they facilitate, process conditions can inhibit or stop enzymatic action. Temperature, pH and the presence of heavy metal ions can alter the shape of enzyme molecules and thereby prevent them from facilitating reactions. Also, the enzymes may be destroyed when the concentration of reaction products gets too high.

Nature provides a vast array of enzymes that enable many essential biochemical reactions, and new enzymes with new capabilities are now being produced by genetic engineering. It is indeed fortunate that this vast array of useful enzymes is available from nature and that modern technology is now capable of expanding this resource.

Ethanol from Natural Sugars

Some plants, such as sugar cane and sugar beets, produce sucrose. Sucrose is a disaccharide, a combination of two monosaccharide components called glucose and fructose. Hydrolysis of sucrose into glucose and fructose may be accomplished by enzymatic action. Processes facilitated by enzymes are generally simpler and more economical than other types of processes (such as thermochemical processes).

Sugar cane is the raw material for a huge ethanol production program (around 7 billion gallons per year in the early twenty-first century) in Brazil.

Ethanol from Starch

Some plants, such as potatoes and corn, are rich in starch. Starch is made up of a string of glucose components. Hydrolysis of starch into glucose may be accomplished by enzymatic action.

Ethanol from Cellulose

Cellulose is the most abundant carbohydrate in nature. Grasses, leaves, plant stalks, bushes and trees are mostly cellulose and hemicellulose.

Like starch, cellulose consists of a chain of linked glucose elements, but the structural orientation of the cellulose molecule is different than that of starch. An enzyme called cellulase exists in the digestive systems of certain animals and insects, including cows and termites. It can hydrolyze cellulosic materials (humans cannot). A problem in large-scale ethanol production from cellulose is the unavailability of a plentiful and inexpensive supply of effective enzymes for processing cellulosic materials. Scientists are searching for genetically engineered enzymes that can accomplish the hydrolysis of cellulose (and maybe hemicellulose simultaneously) efficiently and inexpensively.

Industrial hydrolysis also may be accomplished with an acid process, usually involving sulfuric acid. Cellulose hydrolysis requires use of concentrated acid. Acid hydrolysis is well developed, but the process requires use of hazardous and corrosive liquids. Consequently, there is a strong incentive to develop an effective and inexpensive enzymatic process.

The production of cellulosic ethanol suffers from another significant problem. Cellulose and hemicellulose in plant material exist in packets encased in a tough, fibrous non-carbohydrate material called lignin. It is necessary to free the cellulose (and hemicellulose) from its lignin envelope before hydrolysis can ensue. This requires grinding the material or solvent extraction.

Sugars and starches are valuable as human foodstuffs, so there is an incentive to overcome the greater difficulty of using cellulose and hemicellulose for ethanol production since the raw material is abundant, cheap and unsuitable as a human foodstuff. Agricultural and forest wastes are potential feedstocks. In addition, crops such as switchgrass may be grown for cellulosic feedstock on farmland that is too poor in quality for traditional agricultural production.

Ethanol from Hemicellulose

Hemicellulose is found along with cellulose enclosed in lignin sheaths in plants. Hemicellulose is a polysaccharide consisting of different types of sugar components. Some of the sugars are six carbon sugars (hexoses like glucose and fructose), and some are five carbon sugars. The presence of an array of different sugar types after hydrolysis complicates the development of suitable fermentation enzymes.

Hemicellulose, like cellulose, also can be hydrolyzed by an acid process. Dilute acid is used to hydrolyze hemicellulose as opposed to the concentrated acid needed for cellulose hydrolysis.

Lignin in Biochemically-Produced Ethanol

Lignin is the fibrous structural material in plants. It is an organic polymer with a high molecular weight. It makes up one-fourth to one-third of plant materials. Lignin cannot be hydrolyzed and fermented into ethanol like sucrose, starch, cellulose or hemicellulose, and consequently, is not a source material for the biochemical production of ethanol. However, lignin will burn and is therefore used in the ethanol production process as a fuel to provide needed process heat.

As will be discussed in Appendix N, butanol, whose fermentation does not require monosaccharide intermediates, can be produced with lignin as well

as with carbohydrates. Lignin can also be processed thermochemically to break down the molecules and reconstruct the components as useful bio-fuels (see Section 7.5).

Bioethanol Energy Balance

The efficiency of bioethanol production is important for assessing the practicality of large-scale production. However, one should realize that different energy efficiency metrics can be defined. For example, if the objective is reducing the need for petroleum by switching to bioethanol, the logical efficiency metric is the ratio of bioethanol energy content to the energy content of the petroleum products used in producing the bioethanol. Another objective is maximizing the conversion of biomass stored energy into energy in the bioethanol produced. The metric in this case is the ratio of bioethanol energy to the energy stored in the biomass. Greater values of this metric indicate that less land is required grow the amount of biomass needed to produce a given amount of bioethanol.

The National Renewable Energy Laboratory performed detailed design studies of two types of bioethanol manufacturing plants. One plant used enzymatic processing of corn stover¹, and the other used thermochemical processing of biomass². In both studies, the energy and material flows in the plants were such that no external energy inputs were required. The computed efficiencies (energy in produced biofuel/energy contained in biomass feedstock) were around 50 percent. These studies illustrate the point that no fossil fuels are necessary for the conversion of biomass into bioethanol. Process energy is required, but it derived from the biomass, some of which could have otherwise been converted into bioethanol. Additional energy is required to plant, fertilize, harvest, transport and (possibly) dry the biomass. These energy expenditures are usually attributed to oil and gas in energy efficiency assessments, but all of these requirements could also be met with bioethanol.

Of course, it may be economical and convenient to use some fossil fuel energy in producing bioethanol. In this case, bioethanol production may be increased at the expense of fossil fuel consumption.

Energy efficiency is a metric whose misuse or misunderstanding can cause confusion about the viability of bioethanol production. For example, assume that some process captures 33 percent of the energy in biomass feedstock as energy contained in the bioethanol produced and no fossil fuel or electricity is used. One way to state the energy efficiency is:

This production method uses more energy than is contained in the bioethanol product. In fact, two BTUs are wasted for every BTU available in the ethanol produced.

Another way to state the energy efficiency is:

This production method captures one-third of the energy contained in the biomass feedstock as energy contained in the bioethanol produced without requiring any external energy inputs.

Both statements are true, but one is designed to convey an impression of unacceptability, and the other is designed to convey an impression of acceptability. These examples illustrate that the technique called “spin” in political discourse also can be employed in energy discussions.

The efficiency of bioethanol production has been the subject of heated debate. The debate hinges on an assessment of the BTU expenditure required to produce a BTU of bioethanol energy. If the energy available from the biofuel is less than the energy required to produce the biomass, transport it and convert it into bioethanol, then external sources (oil, natural gas, coal or electricity) must be used to make up the deficit. Many studies have been performed to assess energy efficiency and almost all conclude that the energy balance is positive, even for the technology used for producing bioethanol from corn.

It should also be noted that the desirability of a specific fuel production process depends on other factors in addition to energy efficiency. Some of these factors are:

- A protein-rich by-product of starch-to-ethanol production is valuable as a livestock feed.
- Biomass can be converted into materials that can replace oil and natural gas as a feedstock to make chemicals needed to sustain modern civilization. Thus, biomass can reduce fossil fuel dependency in more ways than solely as an energy source.
- Conversion of an energy resource into a more useful form can override energy efficiency concerns. For example, hydrogen production always consumes more energy than is contained in the hydrogen produced. Electricity production in power plants fueled by coal, natural gas, oil or uranium always results in wasting about two BTUs for every BTU of electricity produced. Liquid biofuel is more useful than the solid biomass from which it was produced.

The bottom line on the issue of energy efficiency in biofuel production is that greater efficiency is a good thing, but it is not a basis for dismissing biofuel as a major part of our energy future. Emphasis on energy efficiency in judging the desirability of ethanol production should diminish to its appropriate level of secondary importance compared to the importance of reducing fossil fuel dependence. Diminished emphasis will reduce misleading reports in the popular press by poorly-informed journalists and inappropriate prioritizations by poorly-informed politicians.

Ethanol Imports

Just as the U.S. counts on domestic and imported petroleum, ethanol imports will certainly be used to supplement domestic production. The yield of biofuels in tropical regions is as much as five times higher than in temperate regions. This greater productivity is due to crops with higher

growth rates and longer, even year-round, growing seasons. Brazil is poised to become a major supplier of biofuels, largely because of its huge capacity for producing ethanol from sugarcane. It has developed the agricultural and processing infrastructure needed to eliminate the need for oil imports and to provide a foundation for developing a large export industry.

The countries with the greatest biofuel production potential may be tempted to maximize production at the expense of environmental degradation. Nations and businesses will face policy decisions that will have lasting impacts.

If exporters become dependent on exported biofuel income to sustain their economies, and importers become dependent on imported biofuels to satisfy their energy needs, new patterns of political and economic opportunity and vulnerability will evolve. The current concern about the stability of oil-exporting countries could be replaced by a similar concern about biofuel-exporting countries.

Ethanol as a Transportation Fuel

Ethanol may be used as a fuel in internal combustion engines, but use of pure ethanol requires engine modification. Because ethanol contains significant oxygen (one oxygen for every two carbon atoms and every five hydrogen atoms), less oxygen is needed for combustion than for gasoline. This contained oxygen reduces the need for oxygen from the air and necessitates a leaner fuel/air mixture.

Ethanol will mix with gasoline, and this mixture may be used to fuel internal combustion engines. Ethanol/gasoline mixtures are designated by the letter E, followed by the numerical percentage of ethanol in the mixture. Common mixtures are E10 and E85.

Ethanol is not compatible with some plastics and metals commonly used in engines and fuel systems, requiring modifications that eliminate these materials for pure ethanol or E85.

A gallon of ethanol has only about two-thirds as much energy content as a gallon of gasoline. Ethanol use would require a larger fuel tank to achieve the same range as gasoline. However, ethanol has a higher octane rating than gasoline. Higher octane fuels have a lesser tendency to ignite prematurely in an engine. Use of ethanol fuel may permit higher compression ratios in engines and thereby improve the efficiency of conversion of chemical energy into mechanical energy.

Transportation of liquid and gaseous fuel is best done in pipelines. Oil and natural gas pipelines crisscross the United States. If bioethanol becomes a major fuel, dedicated pipelines for ethanol transportation from source to consumer will be required. Existing pipelines do not provide the isolation from water required for ethanol. Dedicated pipelines for ethanol will be required.

Ethanol Environmental Effects

Manufacturing and burning ethanol release carbon dioxide, a gas that contributes to global warming. However, the amount of carbon dioxide released is exactly equal to the carbon dioxide removed from the air during production of the biomass during photosynthesis. Consequently, biofuels are neutral with respect to carbon dioxide release and resulting contributions to global warming. The concentrated carbon dioxide released during ethanol production may facilitate collection for sequestration or for providing a CO₂-rich environment to increase the growth rate in special algal growth chambers. It may even prove viable to use nuclear energy to provide the energy required to recombine the carbon dioxide released in ethanol production with water to construct synthetic carbohydrates. All of these possible steps serve to reduce increases in atmospheric carbon dioxide.

Of course, growing biomass requires water. If biomass is grown specifically for biofuel production in areas that require irrigation, then water use may become an environmental issue in biofuel production.

Since ethanol is free of problematic chemicals such as sulfur, using ethanol as a fuel does not cause the release of pollution related to these materials. Burning ethanol in air does expose atmospheric nitrogen to high temperatures, resulting in the production of oxides of nitrogen.

An important, but rarely mentioned, consequence of removing biomass from the fields where it was grown is the effect on soil fertility. Plants need nutrients in the soil in order to grow. This includes nitrogen, phosphorous, potassium and small amounts of many different minerals. When dead plant matter in the form of farming residue is left in the field, these nutrients return to the soil for use by subsequent generations of plants. If the biomass is removed for conversion to biofuel, the nutrients are also removed. If the needed nutrients are not restored, plant growth will stop eventually. Fertilizers are used to provide these nutrients. Introducing a large biofuel industry will create a related large increase in fertilizer requirements. Some of these materials will be recoverable at the biofuel production facilities as by-products, but producing, delivering and using the increased fertilizer quantities will create new costs and energy use requirements.

References

1. Aden, A., Ruth, M., Jechura, J., Neeves, K., Sheehan, J. and Wallace, B. "Lignocellulosic Biomass to Ethanol Process Design and Economics Utilizing C-Current Dilute Acid Prehydrolysis and Enzymatic Hydrolysis for Corn Stover" *National Renewable Energy Laboratory Report NREL/TP-510-32438* June 2002.
2. Philips, S., Aden, A., Jechura, J. and Dayton, D. "Thermochemical Ethanol via Indirect Gasification and Mixed Alcohol Synthesis of Lignocellulosic Biomass" *National Renewable Energy Laboratory Report NREL/TP-510-41168* April 2007.

APPENDIX N: BIOBUTANOL

Butanol Properties

Butanol is a four-carbon alcohol, C₄H₉OH. It is a clear liquid with a specific gravity of 0.81. Like bioethanol, it may be produced by biochemical means, but the currently developed production technology for biobutanol is a bit more complex than bioethanol production technology. Biobutanol has some advantages over bioethanol as a fuel, and there are some who say that emphasis should shift from bioethanol production to biobutanol.

Some advantages of butanol properties relative to its use as a fuel are as follows:

- Butanol has a low heating value (LHV) of 14,800 BTU per pound (99,800 BTU per gallon) and a high heating value (HHV) of 16,100 BTU per pound (108,500 BTU per gallon). Butanol heating values are about 30 percent higher than ethanol heating values and about 86 percent of gasoline heating values.
- Butanol is compatible with common metals and plastics.
- Butanol is immiscible with water. Contact with liquid water or water vapor does not contaminate butanol. This property would facilitate transport in pipelines.
- Butanol has a low vapor pressure (it does not readily evaporate).
- Butanol is more viscous than gasoline or ethanol (more flow resistant, a disadvantage).

Combustion of butanol proceeds as follows:

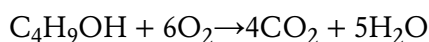

Butanol Production

Butanol was produced biochemically in 1916 as an unwanted byproduct of a process to produce acetone needed in munitions manufacture. The biochemical process produced acetone, butanol, and ethanol. It is usually referred to as the A.B.E. process. Subsequent research has focused on developing processes with greater butanol yields. One such process operates in two stages, with different enzymes for each stage. The first stage enzyme causes conversion of biomass into butyric acid ($C_4H_8O_2$) and hydrogen, and the second stage, using the same enzyme as originally used in the A.B.E. process, converts butyric acid into butanol. This process does not involve the hydrolysis of starch, cellulose, or hemicellulose into simple sugars. It can use the lignin as well as the carbohydrate components of biomass. The two-stage process produces butanol and hydrogen, both useful in energy production.

APPENDIX O: BIOMETHANE

Methane is valuable as a fuel and as a feedstock for producing other useful compounds. Methane, CH₄, is the simplest hydrocarbon. It is a colorless gas with a high heating value (HHV) of 1,011 BTU per cubic foot and a low heating value (LHV) of 910 BTU per cubic foot (measured at standard temperature and pressure). Methane may be extracted from underground deposits (as natural gas, a fossil fuel), or it may be produced from coal (as a fossil fuel derivative) or from biomass.

Biomass decay occurs in the presence of oxygen (aerobic) and in the absence of oxygen (anaerobic). Both decay processes involve microbes that digest the biomass. Dead biomass that falls to the ground encounters aerobic microbes that feed on the biomass as long as they have access to atmospheric oxygen. If biomass is denied oxygen by burial under dirt or accumulated biomass or by being submerged in water, then anaerobic microbes take over and digest the material.

The biochemical route to methane production is by the anaerobic digestion of organic matter by certain microorganisms. Landfills and accumulated animal waste are potential sources of biomethane.

The products of aerobic digestion are carbon dioxide and water. These substances, used in photosynthesis, are returned to the environment. Materials left in the soil after microbial digestion (aerobic or anaerobic) include nutrients necessary for subsequent plant growth. These nutrients include nitrogen, potassium phosphorous, and a number of other elements needed for plant growth. Without the recycling of these substances, plant growth would stop.

Methane release into the atmosphere contributes to global warming. Its potency per molecule of its greenhouse effect is over 20 times stronger than that of carbon dioxide.

The products of anaerobic digestion are primarily methane and carbon dioxide. Methane produced in natural settings escapes to the atmosphere, where it contributes to global warming. Methane produced in landfills and in accumulated animal waste will also escape to the atmosphere unless it is captured.

Some newer landfills have collection pipes buried along with the waste material being buried. Fans draw gas, called *biogas*, from the landfill as it is being produced. This biogas can be used as a fuel, but its heating value is less than pure methane because of the associated carbon dioxide.

The modest quantity of biogas from landfills will never be a major source of energy. However, the reduction of methane release to the atmosphere is at least as important as the energy obtained from biogas.

Methane is also produced in the digestive systems of certain animals and insects and is released into the atmosphere. Cows are one such source of methane, and any increase in their numbers is accompanied by a proportional increase in methane release.

APPENDIX P: PHYSICS OF FALLING AND MOVING FLUIDS

Hydroelectric dams and river diversion systems use the kinetic energy of falling water to produce electrical energy by the use of turbine-generators. Wind turbines and water turbines use the kinetic energy of flowing wind or water to produce electrical energy. This Appendix describes the assessment of the energy and power available from these sources and the important issue of the units used in these assessments.

Falling Water

In a dam-based hydroelectric facility, a dam creates an elevated water reservoir. Turbine-generators use water released from the reservoir to produce electricity.

A river diversion system uses water from a river that drops naturally over a short distance. Water passes from a higher upstream point through a tunnel or pipes to a turbine at a lower elevation.

The power of the falling water is the rate at which potential energy, PE, is released (the energy per unit of mass times the rate at which mass falls). That is:

$$PE = mgh \quad (P-1)$$

where:

m = mass

g = gravitational constant

h = height

The potential energy per unit of mass is given by:

$$PE/m = gh \quad (P-2)$$

The power delivered in falling from a height, h , is:

$$P = (PE/m) \times (dm/dt) = fgh \quad (P-3)$$

where:

P = power

$f = dm/dt$ = flow rate (mass per unit time)

Use of Equation P-3 requires caution. One must properly distinguish between mass and weight. Mass, m , is an intrinsic property that measures the inertia of a quantity of material. Weight, W , is the force acting on a quantity of material caused by gravity and is equal to:

$$W = mg \quad (P-4)$$

where:

W = weight

Rewriting Equation P-1 gives:

$$PE = Wh \quad (P-5)$$

The potential energy per unit of weight is:

$$PE/W = h \quad (P-6)$$

The power delivered in falling from height h is:

$$P = (PE/W) \times (dW/dt) = Fh \quad (P-7)$$

where:

$F = dW/dt$ = weight flow rate (weight per unit time)

Example P-1

Parts of the upper Tennessee River flow at a rate of around 30,000 cubic feet per second or about 1.9 million pounds per second. Practical dam heights in this region are around 70 feet. Therefore, based on Equation P-7, the power of water flowing from a reservoir to the river below is about $1.9 \times 10^6 \times 70 = 1.33 \times 10^8$ foot pounds per second. Using the conversion from foot pounds to Joules (1.356 Joules per foot pound) gives a result of about 1.8×10^8 Joules per second. Since a watt is defined as one Joule per second, the power of the falling water is about 180 megawatts. This is the maximum power available. Electrical power generation capacity is limited by the efficiency of the turbine-generator.

Now let us repeat the calculation using SI units. A weight flow of 1.9 million pounds per second equals a mass flow (in SI units) of 864,000 kilograms per second. The dam height, 70 feet in U.S. Customary units, is 21.3 meters in SI units. Using Equation P-3 gives $864,000 \times 9.81 \times 21.3 = 1.8 \times 10^6$, illustrating the consistency of calculations in the U.S. Customary and SI systems.

Flowing Wind and Water

Wind turbines or water turbines operate by capturing part of the kinetic energy in a flowing stream of wind or water. The power contained in the stream is the kinetic energy per unit of mass times the rate at which the mass is flowing. That is:

$$KE = (1/2)mv^2 \quad (P-8)$$

$$KE/m = (1/2)v^2 \quad (P-9)$$

$$P = (1/2)v^2 f \quad (P-10)$$

where:

m = mass

v = velocity

KE = kinetic energy

P = power

f = mass flow rate

But the mass flow rate, f , is given by:

$$f = \rho Av \quad (P-11)$$

where:

ρ = mass density of air or water (mass per unit volume)

A = area of turbine blades facing the air or water flow

Consequently:

$$P = (1/2)\rho Av^3 \quad (P-12)$$

Caution: weight density (weight per unit volume) must be converted to mass density (mass per unit volume) for use in Equation P-12.

Example P-2

Consider a wind turbine with blades 100 feet long in air flowing at 15 miles per hour. The density of air is about 0.0749 pounds per cubic foot or, converting to mass density by dividing by 32.2, 0.00233 slugs per cubic foot. The velocity of 15 miles per hour is equal to 22 feet per second. The power in the air stream aimed at the turbine is:

$$\begin{aligned} P &= (1/2) \times 0.00233 \times 3.14159 \times 100^2 \times 22^3 \\ &= 389,000 \text{ foot pounds per second} \end{aligned}$$

This power is equal to $389,000 \times 1.356$ (Joules per foot pound) = 529,000 Joules per second or 0.529 megawatts. This power is contained in the wind, only part of which can be captured by the wind turbine.

Now let us repeat the calculation using SI units. The density of air is 1.2 kilograms per cubic meter. The 100 foot blades are 30.48 meters long, and a wind speed of 15 miles per hour corresponds to 6.71 meters per second. The power is:

$$\begin{aligned} P(\text{Joules per second}) &= (1/2) \times 1.2 \times 3.14159 \times 30.48^2 \times 6.71^3 \\ &= 529,000 \text{ (Joules per second)} \\ &= 0.529 \text{ megawatts} \end{aligned}$$

Example P-3

Consider a turbine with 10 foot blades immersed in a stream of water flowing at 2 miles per hour (or 2.93 feet per second). The weight density of water is about 62.4 pounds per cubic foot or a mass density of 1.94 slugs per cubic foot. The kinetic energy of the water stream aimed at the turbine is:

$$\begin{aligned} E \text{ (foot pounds per second)} &= (1/2) \times 1.94 \times 3.14159 \times 10^2 \times 2.93^3 \\ &= 7,665 \end{aligned}$$

Conversion to Joules per second by multiplying by 1.356 gives 10,400 watts or 10.4 kilowatts.

Summary

The results presented above may be summarized concisely to facilitate assessments of energy production potential. The formulas presented below use typical values for the densities of air and water, and mass density and weight density are handled correctly.

The maximum power in falling water released from a reservoir is:

$$P(\text{watts}) = 1.356 \times \text{flow (in pounds per second)} \times \text{height (in feet)} \quad (\text{P-13})$$

or:

$$P(\text{watts}) = 0.188 \times \text{flow (in gallons per minute)} \times \text{height (in feet)} \quad (\text{P-14})$$

or:

$$P(\text{watts}) = 84.6 \times \text{flow(in cubic feet per second)} \times \text{height (in feet)} \quad (\text{P-15})$$

or:

$$P(\text{watts}) = 9.81 \times \text{flow(in kilograms per second)} \times \text{height (in meters)} \quad (\text{P-16})$$

The maximum power in an air stream aimed at the turbine is:

$$P(\text{watts}) = 0.00497 \times (\text{blade radius in feet})^2 \times (\text{wind speed in feet per second})^3 \quad (\text{P-17})$$

or:

$$P(\text{watts}) = 0.0157 \times (\text{blade radius in feet})^2 \times (\text{wind speed in miles per hour})^3 \quad (\text{P-18})$$

or:

$$P(\text{watts}) = 1.89 \times (\text{blade radius in meters})^2 \times (\text{wind speed in meters per second})^3 \quad (\text{P-19})$$

For water turbines, the relations are:

$$P(\text{watts}) = 4.13 \times (\text{blade radius in feet})^2 \times (\text{water flow rate in feet per second})^3 \quad (\text{P-20})$$

or:

$$P(\text{watts}) = 13.1 \times (\text{blade radius in feet})^2 \times (\text{water flow in miles per hour})^3 \quad (\text{P-21})$$

or:

$$P(\text{watts}) = 1571 \times (\text{blade radius in meters})^2 \times (\text{water flow in meters per second})^3 \quad (\text{P-22})$$

Of course, the delivered power will be less than the maximum power given by these formulas. Energy loss occurs in converting kinetic energy into mechanical energy and in converting mechanical energy into electrical energy. The Lanchester-Betz-Joukowsky kinetic to mechanical energy conversion limit (59 percent) applies to wind and water turbines.

There is some interest in using ducted water turbines. These funnel the water from a larger diameter entrance opening into the smaller diameter opening around the turbine blades. These systems provide higher efficiencies for a given turbine blade diameter than the Lanchester-Betz-Joukowsky limit, but this limit still applies to the size of the entrance opening. That is, the system can extract no more than 59 percent of the kinetic energy in a stream with a cross-sectional area equal to that of the duct entrance.

APPENDIX Q: ENERGY USE IN SPECIFIC INDUSTRIES

Energy use in the main energy-consuming industries is shown in Table Q-1 (a repeat of Table 17-1).

Table Q-1. Delivered Energy Consumption by Industry (1998)¹

Manufacturing	Consumption Trillion BTU
Food	1,029
Paper	2,726
Bulk Chemicals	6,697
Petroleum Refining	3,127
Glass	198
Cement	356
Steel	1,590
Aluminum	454
Metal-Based Durables	1,466
Others	2,904
Total Manufacturing	20,546
Non-Manufacturing	
Agriculture-Crops	711
Agriculture-Other	412
Coal Mining	87
Oil and Gas Extraction	1,509
Other Mining	310
Construction	1,776
Total Non-Manufacturing	4,805
Total for All Industry	25,353

The following sections provide information about each of these industries, along with charts that illustrate the relative contributions of the various energy sources.

Food

The food industry uses about 4 percent of delivered industrial energy. See Figure Q-1 for the relative contributions of energy sources used in the food industry. Natural gas provides slightly more than half of the delivered energy.

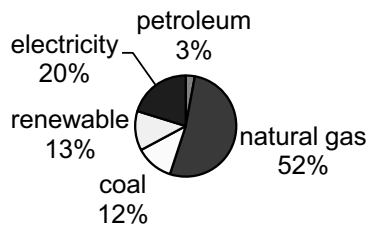

Figure Q-1. Energy Sources in the Food Industry
(data from the U.S. Dept. of Energy)

The main uses of energy in the food industry include process heating, process cooling, and machine drives.

Paper

The paper industry uses about 11 percent of delivered industrial energy. See Figure Q-2 for the relative contributions of energy sources used in the paper industry. The paper industry is unique in that it derives almost half of the delivered energy used for paper manufacture from renewables. The wood waste and waste from the pulp wood processing are burned to produce heat.

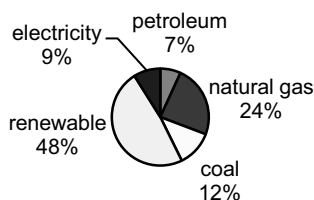

Figure Q-2. Energy Sources in the Paper Industry
(data from the U.S. Dept. of Energy)

The main uses of energy in the paper industry include wood preparation, pulping, bleaching, drying, and paper fabrication.

Bulk Chemicals

The bulk chemicals industry is the largest energy consumer in the industrial sector, using about one-fourth of delivered industrial energy. See Figure Q-3 for the relative contributions of energy sources used in the chemical industry. No single energy source is dominant in the chemical industry.

The bulk chemicals industry uses energy resources as fuel and as feedstocks for producing various chemicals. Petroleum and natural gas are used heavily for fuel and feedstock. Feedstocks account for over half of delivered energy consumption in the bulk chemicals industry.

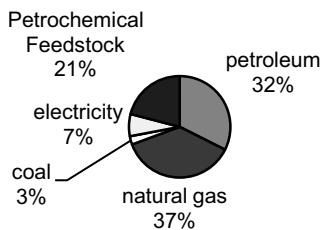

Figure Q-3. Energy Sources in the Bulk Chemicals Industry
(data from the U.S. Dept. of Energy)

The main energy-related uses for fuel in the bulk chemicals industry include process heating, process cooling and refrigeration, machine drives, and electrochemical processes. Chemicals produced from energy resource feedstocks include fertilizers, insecticides, and plastics.

Petroleum Refining

Petroleum refining uses about 12 percent of delivered energy consumed by U.S. industry. See Figure Q-4 for the relative contributions of energy sources used in petroleum refining. Two-thirds of the energy needed for petroleum refining is derived from petroleum delivered to the refinery. Refineries also provide non-fuel products such as petrochemical feedstocks and asphalt, which are treated as energy inputs for other appropriate industries.

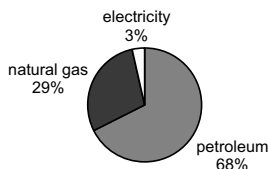

Figure Q-4. Energy Sources in the Petroleum Refining Industry
(data from the U.S. Dept. of Energy)

Operations in a refinery include separating the components in crude oil, breaking large molecules into smaller molecules, changing the chemical structure of the components of crude oil, combining small molecules into larger molecules, and eliminating unwanted components of crude oil.

The main uses of energy in petroleum refining are fluid heating and steam generation.

A discussion of refining technology appears in Chapter 3.

Glass

The glass industry uses less than 1 percent of delivered industrial energy. See Figure Q-5 for the relative contributions of energy sources used in the glass industry. The main energy source for the glass industry is natural gas.

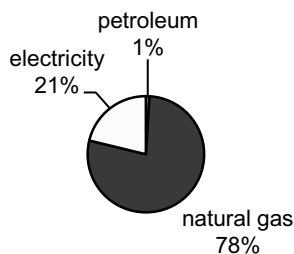

Figure Q-5. Energy Sources in the Glass Industry
(data from the U.S. Dept. of Energy)

Silica (SiO_2) is the main component of glass (usually 70 to 74 percent). Other components are added to simplify glass making or to obtain desired glass properties for certain applications. Common additives are sodium carbonate, lime (calcium oxide), magnesium oxide, and aluminum oxide. Materials added for certain specialty glasses include lead (for “leaded” glass) and boron (for Pyrex).

The main use of energy in the glass industry is for gas-fueled melting furnaces. The silica and other components are melted and then cooled to form solid glass. The resulting glass lacks a crystal structure (it is an amorphous solid) and is therefore similar to liquids in structure.

Cement

The cement industry uses less than 2 percent of delivered industrial energy. See Figure Q-6 for the relative contributions of energy sources used in the cement industry.

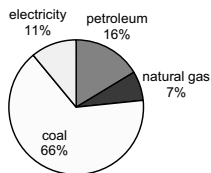

Figure Q-6. Energy Sources in the Cement Industry
(data from the U.S. Dept. of Energy)

The main use of energy in the cement industry is for heating the minerals (mainly alumina, silica, lime, iron oxide, and magnesia) used to produce cement. Kilns are used to heat the materials to around 2700°F to achieve the necessary reactions and phase changes. The main uses of cement are for concrete and mortar in construction applications.

Coal provides about three-fourths of the energy used in cement production.

Steel

The steel industry uses about 8 percent of delivered industrial energy. See Figure Q-7 for the relative contributions of energy sources used in the steel industry.

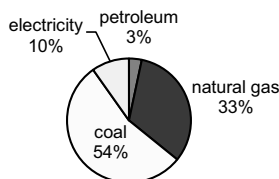

Figure Q-7. Energy Sources in the Steel Industry
(data from the U.S. Dept. of Energy)

Steelmaking from iron ore involves three main steps:

- Producing coke from coal. Coke, essentially pure carbon, results from heating pulverized bituminous coal to a high temperature in the absence of oxygen.
- Separating iron from iron ore in a blast furnace. Iron ore, coke, air, and limestone are fed into blast furnaces. The coke burns to produce the necessary heat and also provides the small concentration of carbon needed in steel.
- Refinement of iron into steel in a basic oxide furnace. Basic oxide furnaces use high purity oxygen to combust carbon and silicon in the iron from a blast furnace. Alloying materials are combined with the purified iron to make steel.

Steel is also recycled. Electric arc furnaces for processing scrap steel use electrical energy and oxygen to process scrap steel and prepare it for re-use.

Coal accounts for more than half of the delivered energy in the steel industry. Coal is used mainly to produce coke that is used in blast furnaces.

Steel industry energy is used mainly for blast furnaces, electric arc furnaces, casting, rolling, and finishing.

Aluminum

The aluminum industry uses about 2 percent of delivered industrial energy. See Figure Q-8 for the relative contributions of energy sources used in the aluminum industry.

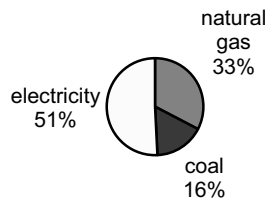

Figure Q-8. Energy Sources in the Aluminum Industry
(data from the U.S. Dept. of Energy)

Producing aluminum metal from aluminum ore (bauxite) involves three steps:

- Separation of aluminum oxide from other components in bauxite. The Bayer process is based on reaction of aluminum oxide with sodium hydroxide at high temperature and pressure.
- Crystallization and drying of the aluminum oxide.
- Reducing aluminum oxide to aluminum metal. The Hall-Heroult process involves electrolytic production of aluminum metal from aluminum oxide.

Aluminum is also recycled. Scrap is melted and purified to prepare aluminum for re-use.

Aluminum production requires large quantities of energy for heating and electrolytic processes. The aluminum industry is unique in its use of electricity for about half of its energy.

Metal-Based Durables

The metals-based durables industry uses about 6 percent of delivered industrial energy. See Figure Q-9 for the relative contributions of energy sources used in the metals-based durables industry. The metals-based durables industry includes fabricated metal products, machinery, electric and electronic equipment, transportation equipment, and instruments and related products.

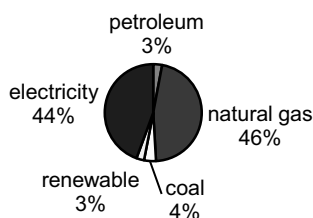

Figure Q-9. Energy Sources in the Metal-Based Durables Industry
(data from the U.S. Dept. of Energy)

One industry in this group, the transportation equipment manufacturing industry (cars, trucks, airplanes, ships, rail), warrants special mention. Transportation equipment manufacture accounts for about 2 percent of delivered industrial energy. This energy expenditure, along with other energy used to enable transportation (such as energy for oil refining, steel manufacture for equipment, and road construction), adds to the energy used for transportation and contributes to the true total energy cost for transportation.

Balance of Manufacturing

The balance of the manufacturing sector includes all manufacturing processes other than those energy-intensive industries described above. These industries use about 11 percent of delivered industrial energy. See Figure Q-10 for the relative contributions of energy resources used in these industries.

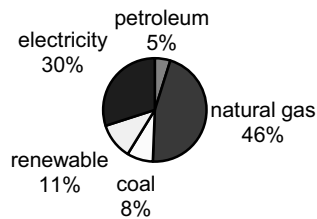

Figure Q-10. Energy Sources in Other Manufacturing Industries
(data from the U.S. Dept. of Energy)

Agriculture

Agriculture is a small user of energy compared to total U.S. consumption³. Delivered energy consumption in agriculture is about 4 percent of total industrial consumption. See Figure Q-11 for the relative contributions of energy sources used in agriculture.

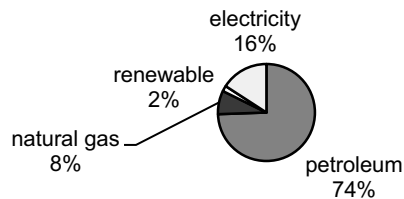

Figure Q-11. Energy Sources in Agriculture (data from the U.S. Dept. of Energy)

Delivered energy is used primarily for growing crops, producing animals, forestry and logging, fishing, and various support activities.

Agricultural activities also require indirect energy use to produce farm chemicals (mainly fertilizers and pesticides). Energy for the production of farm chemicals is counted in data tabulations as energy use in the industries that produce the chemicals. However, the energy use is ultimately for agricultural purposes. Agricultural chemical production accounts for about 0.6 percent of industrial delivered energy consumption.

Mining

The mining industry uses less than 2 percent of delivered industrial energy². See Figure Q-12 for the relative contributions of energy sources used in the mining industry. Mining involves the removal of solid materials from the earth. These are classified as coal, metals (primarily iron, copper, lead, and zinc), and industrial minerals (primarily potash, soda ash, borates, phosphate rock, limestone, and other crushed rock).

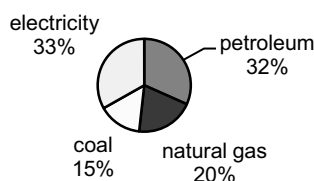

Figure Q-12. Energy Sources in the Mining Industry
(data from the U.S. Dept. of Energy)

In addition to domestic mining products, America also uses minerals mined in other countries. For example, bauxite for aluminum manufacture is mined abroad, as are most of the gold and gemstones used for jewelry.

Petroleum and electricity are the main energy sources for the mining industry. Energy uses are about 19 percent for ore extraction, 42 percent for materials handling, and 39 percent for processing (mostly grinding and crushing). The desired materials constitute only a portion of the material that must be handled and processed in mining operations. The proportions of desired materials in ores range from about one-half for industrial materials to about 4 percent for metals.

Oil and Gas Extraction

The oil and gas extraction industry uses about 6 percent of delivered industrial energy. See Figure Q-13 for the relative contributions of energy sources used in the oil and gas extraction industry. “Lease and plant fuel” is natural gas used in well, field, and lease operations (such as gas used in drilling operations, heaters, dehydrators, and field compressors) and as fuel in natural gas processing plants.

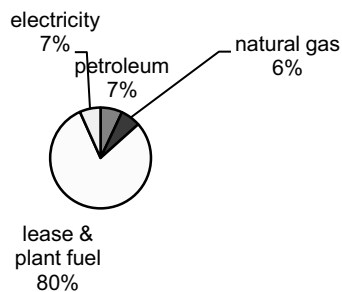

Figure Q-13. Energy Sources in Oil and Gas Extraction
(data from the U.S. Dept. of Energy)

Construction

The construction industry uses about 7 percent of delivered industrial energy. See Figure Q-14 for the relative contributions of energy sources used in the construction industry.

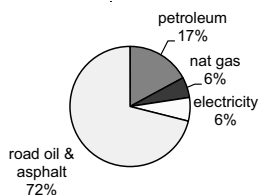

Figure Q-14. Energy Sources in Construction (data from the U.S. Dept. of Energy)

Asphalt, used mainly for road construction, accounts for over 70 percent of delivered construction energy.

References

1. Unruh, B. "Delivered Energy Consumption Projections by Industry" *Annual Energy Outlook 2002* Energy Information Administration Document, 2002 at <http://www.eia.gov/oiaf/analysispaper/industry/consumption.html>.
2. U.S. Department of Energy, Energy Efficiency and Renewable Energy Report "Energy and Environmental Profile of the U.S. Mining Industry" at <http://www1.eere.energy.gov/industry/mining/analysis.html>.
3. Schnepf, R. "Energy Use in Agriculture: Background and Issues" Congressional Research Service, the Library of Congress, 2004.

GLOSSARY

The following is a glossary of terms used in this book. It is provided to serve as an easy-to-use reminder of terms whose meaning may have been forgotten by the reader.

Definitions presented here include only those terms that appear in the body and appendices of this book and are pertinent to the terms' usage in the book. A more comprehensive glossary of energy-related terms appears on the Energy Information Administration web site: <http://www.eia.doe.gov>.

Abiogenic: Having been produced without the involvement of biological matter.

Actinide: A member of a group of heavy elements with atomic numbers between 89 and 103. Some actinides are produced by neutron capture in nuclear reactor materials and contribute to radioactivity in nuclear waste.

AFUE (Annual Fuel Utilization Efficiency): The percentage of the energy released by burning fuel that enters a building as warm air.

Air Source: An air conditioner or heat pump that extracts heat from, or dumps heat to, ambient air.

Alcohol: A family of chemicals composed of carbon, hydrogen and oxygen and having a hydroxyl (OH) radical.

Alternative Energy: Non-traditional, sustainable energy.

Ampere: A measure of electrical current.

Anaerobic: Occurring in the absence of air.

Anode: The negative terminal of a battery.

Anthracite: Hard coal.

Anthropogenic: Resulting from human activity.

Atom: The fundamental building block of matter, consisting of electrons swarming around a nucleus composed of protons and neutrons (except in the case of ordinary hydrogen, which has no neutrons).

Bacteria: Microscopic plants.

Barrel of Oil: A standard measure of oil quantity. Equal to 42 U.S. gallons.

Base Load Power Plant: A power plant that operates at constant power output as opposed to a load-following plant that changes power production in response to demand.

Battery: A device for converting chemical energy into electrical energy.

Bergius Process: A process for hydrogenating coal.

Biobutanol: Butanol produced from biomass.

Biochemical Process: A process involving living organisms that enable and/or facilitate chemical reactions.

Biodiesel: Diesel fuel made from biomass.

Biofeedstock: Raw material for chemical processes that comes from biomass.

Biofuel: Fuel made from biomass.

Biogas: A mixture of gases, mostly methane and carbon dioxide, produced in the absence of oxygen from buried organic matter by microbes.

Biohydrogen: Hydrogen made from biomass.

Biomass: Organic material from plants and animals.

Biomethane: Methane made from biomass.

Bio-oil (also, Bio Oil): Oil produced by the pyrolysis of biomass.

Biophotolysis: The process by which plants produce molecular hydrogen through photosynthesis.

Biorefinery: A facility for processing biomass into biofuel.

Biosynthesis: A process wherein chemical compounds are produced within living organisms and are generally catalyzed by enzymes

Bitumen: Hydrocarbons found in oil sand.

Bituminous: Soft coal.

Breeder Reactor: A nuclear reactor that produces more fuel than it consumes (usually by converting U-238 into Pu-239).

British Thermal Unit: The amount of heat needed to raise the temperature of one pound of water by one degree Fahrenheit.

BTU: Abbreviation for British Thermal Unit.

Butane: A hydrocarbon (C_4H_{10}) found in natural gas. Gaseous at normal temperature and pressure.

Butanol: An alcohol (C_4H_9OH).

Calorie: The amount of heat needed to raise the temperature of one gram of water by one degree Celsius.

Calthrate: A substance in which a molecule resides in a cage made of other molecules. Methane calthrate (also called methane hydrate) in the oceans contains large quantities of methane that may someday be recoverable.

Cap and Trade: An agreement in which greenhouse gas emitters are assigned emission quotas and in which unused allowances can be sold to emitters who cannot meet their quotas.

Carbohydrate: A component of biomass consisting of molecules made of carbon, hydrogen and oxygen.

Carbon Sequestration: Isolation of carbon from the atmosphere (generally via underground storage of carbon dioxide).

Catalyst: A material that hastens or enables a chemical reaction without being consumed.

Cathode: The positive terminal of a battery.

CDD: Abbreviation for Cooling Degree Day.

Cellulase: An enzyme that can hydrolyze cellulose.

Cellulose: A carbohydrate component of biomass that consists of linked hexose sugars.

Celsius: The temperature scale in which water freezes at 0 degrees and boils at 100 degrees (at normal, i.e., sea level, atmospheric pressure).

CFL: Abbreviation for Compact Fluorescent Light or Lamp

Chlorophyll: The pigment in plants where photosynthesis occurs.

Closed Cycle Heat Engine: A heat engine in which the working fluid is contained and recycled.

Coal: a solid fossil fuel composed of carbon and hydrocarbons.

Coalbed Methane: Methane trapped in pores in underground coal.

Coalification: The process of converting dead biomass into coal (a slow process that takes place at elevated temperature and pressure).

Coke: A carbonaceous solid material obtained by heating coal or petroleum to drive off hydrogen-bearing components.

Compact Fluorescent Light: A spiral-shaped fluorescent lamp that screws into a standard lamp socket.

Condenser (Heat Exchanger): A heat exchanger that causes a vapor to condense.

Conduction (Heat): Heat transfer through a solid.

Conservation (of Energy): The principle that energy cannot be created or destroyed, but it can change from one form to another.

Convection (Heat): Heat transfer by the motion of a liquid, vapor or gas.

Conventional Gas or Oil: Gas or oil from formations in which natural permeability and porosity permit significant flow to a low pressure region created by a well.

Cooling Degree Days: The number of days when the average temperature is above 65°F times the difference between 65° and the average temperature on a given day.

Corn Stover: The stalks and leaves of corn plants.

Cornucopian: A term for people who believe that there will always be ample energy.

Covalent Bond: A type of chemical bond in which the valence electrons of constituent atoms are shared.

Cracking (Oil): The process of breaking large petroleum hydrocarbon molecules into smaller molecules.

Current (Electric): The flow of electrical charges through a conductor.

Delivered Energy: Energy delivered to a user with no consideration of the energy losses incurred in producing and delivering the energy. See also Primary Energy Consumption.

Demographic Transition: The shift from an era of high birth rates and high death rates to an era of low birth rates and low death rates.

Diesel Engine: A piston-type internal combustion engine in which the fuel is ignited by the compression of air.

Diffusion: Motion of a transportable quantity as the result of a concentration gradient.

Dimethyl Ether: Abbreviated as DME (CH_3OCH_3). DME has the same chemical formula as ethanol, but a different molecular structure.

Dimethylfuran: Abbreviated DMF ($\text{C}_6\text{H}_8\text{O}$). DMF has properties that make it potentially attractive as a biofuel.

Diode: A device that permits the flow of electric current in one direction but prevents flow in the opposite direction.

Disaccharide: A carbohydrate composed of two linked sugar molecules after removal of a water molecule.

Distillate Fuel Oil: Hydrocarbons separated from crude oil by distillation (composed mostly of Diesel fuels and fuel oils).

Distillation: The separation of volatile liquids by exploiting the difference in their boiling points.

Distribution (Electric): The transport of electricity from distribution centers to users.

District Heat: Heating for multiple users that comes from a single source.

Dry Weight: Weight of dried material such as biomass.

Earth Cooling Tubes: Tubes buried in the earth and carrying liquid or air for the purpose of dumping heat into cool subterranean earth.

Efficiency (Thermal): The ratio of energy transformed into a desired form by a thermal process to the maximum energy that could be transformed in a perfect (lossless) transformation.

Electric Power: Power obtained from or conveyed by an electric current.

Electrical Losses: Energy losses incurred in transporting electricity, mainly due to heating in conductors.

Electrochemistry: The branch of chemistry concerned with chemical reactions that occur because of an imposed electric current or with the production of electricity by chemical reactions.

Electrolysis: Dissociation of molecules by the passage of an electric current through a liquid.

Electrolyte: A substance that becomes an ionic conductor of electricity when dissolved.

Electromotive Force: The force that causes an electric current to flow (usually measured in volts).

Electron: A negatively charged atomic particle. Electrons orbit around atomic nuclei and can also exist outside of atoms.

Embodied Energy: The energy used to produce a product.

Energy: The capacity to do work.

Energy Balance: The energy available from using a fuel versus the energy required to get that fuel.

Energy Carrier: Energy that is produced by transforming from another energy source.

Energy Ratio: (Energy available in fuel)/(energy consumed in getting fuel).

Energy Return on Investment: The ratio of the amount of usable energy acquired from a particular energy resource to the amount of energy expended to obtain that energy from the resource.

ENERGY STAR: An international standard for energy efficient consumer products.

Engine: A device for producing mechanical energy from a non-mechanical source of energy. See also Motor.

Enhanced Geothermal System: A geothermal energy system in which the subsurface rock has been modified and a fluid (usually water) is introduced to transport energy to the surface.

Enzyme: A protein that can serve as a catalyst for a biochemical process.

Ethane: A hydrocarbon (C₂H₆). Found in natural gas. Gaseous at normal temperature and pressure.

Ethanol: An alcohol (C₂H₅OH).

Ether: A family of chemical compounds composed of carbon, hydrogen and oxygen with an oxygen atom attached to two carbon atoms.

Evaporative Refrigeration: A term usually reserved for cooling devices that reduce temperature by evaporating water into ambient air.

Evaporator: A heat exchanger in which a liquid evaporates.

Exajoule: 10^{18} Joules.

External Cost (or Externality): The cost of an activity that is incurred by other than the initiator of the activity. The cost may be any undesirable consequence, including financial loss, impaired health, death, and property devaluation.

Fahrenheit: The temperature scale in which water freezes at 32 degrees and boils at 212 degrees (at sea level atmospheric pressure).

Fermentation: An enzymatic conversion.

Fertility Rate (Population): Average number of children per woman.

Field: A region in space where a given effect (such as magnetism) exists.

Fischer-Tropsch Process: A process for producing various compounds of carbon, hydrogen and oxygen from syngas (see also Syngas) in the presence of iron or cobalt catalysts.

Fissile: A term indicating that a material will readily undergo nuclear fission when reacting with a neutron of any energy (slow neutrons to fast neutrons).

Fission (Nuclear): The process in which a reaction between a neutron and a heavy nucleus causes the nucleus to split, producing two or more lighter nuclei, neutrons, gamma rays and energy.

Fission Product: A lighter nucleus produced by the fission of a heavy nucleus.

Fissionable: A term indicating that a material will undergo fission when reacting with a fast neutron.

Food Mile: The distance that a food item travels from grower to consumer.

Force: That which is capable of causing or changing the motion of a body.

Fossil Fuel: A fuel produced from dead plant and animal material that was subjected to elevated heat and pressure when buried beneath the earth for a long period of time.

FPS (Units): An abbreviation for foot, pound, second (units used in the U.S. Customary system of measurement).

Fracking: See Hydrofracturing.

Fractional Distillation: Separation of components in a liquid mixture by repeated vaporization and condensation in a single unit.

Freight Energy Intensity: The energy consumed in freight hauling (BTU per ton-mile).

Fructose: A monosaccharide, $C_6H_{12}O_6$,

Fuel Cell: A device for converting chemical energy into electrical energy via the use of continuously replenished chemicals (typically hydrogen or methane and air).

Fungus: A parasitic lower order plant that lacks chlorophyll.

Fusion: The process in which two atomic nuclei combine, producing a heavier nucleus, neutrons and energy.

Futilitarian: A term for those people who believe that disaster is inevitable.

Gas Absorption: A type of refrigeration system in which the required energy is supplied by heat.

Gas Compression: A type of refrigeration system that achieves cooling by evaporating a liquid in one part of the system, then compressing the resulting vapor and cooling the resulting liquid by heat transfer to the surroundings in another part of the system.

Gas Turbine: A rotary heat engine that extracts energy from a flow of combustion gas.

Gasification: The thermal disassembly of molecules in the presence of limited oxygen.

Gasoline: A liquid hydrocarbon with 5 to 12 carbon atoms per molecule and approximately 2 hydrogen atoms per carbon atom.

Generator (Electric): A device for converting mechanical energy into electrical energy.

Geothermal: Having to do with thermal energy from subsurface regions of the earth.

Geothermal Gradient: The temperature increase per unit of depth in the earth.

Geothermal Heat Pump: A ground-source heat pump. See also Ground Source.

Global Warming: An increase in average atmospheric temperature (natural or anthropogenic).

Glucose: A monosaccharide, $C_6H_{12}O_6$,

Glycerol: An alcohol, $C_3H_5(OH)_3$.

Green Power: Power sources that are environmentally friendly and non-polluting.

Greenhouse Effect: Heating of the atmosphere by trapping radiated heat energy from the earth.

Greenhouse Gas: An atmospheric gas that preferentially absorbs heat energy radiated by the earth.

Ground Source: A type of air conditioner or heat pump that extracts heat from or dumps heat to subsurface earth and/or water.

HDD: The abbreviation for Heating Degree Days.

Heat Dumping: Transferring heat to a thermal mass (see Thermal Mass).

Heat Engine: A device for converting heat energy into mechanical energy.

Heat of Combustion: The quantity of energy released as heat per unit of mass completely combusted.

Heat of Fusion: The quantity of heat energy released per of unit mass from a material upon freezing or absorbed by a material upon melting.

Heat of Vaporization: The quantity of heat energy released per unit of mass vaporized.

Heat Pump: A system that heats by transferring heat from a condenser to a heated space and cools by transferring heat to an evaporator from a cooled space.

Heating Degree Days: The number of days when the average temperature is below 65°F times the difference between 65° and the average temperature on a given day.

Heating Value: The quantity of heat released per unit mass of material oxidized (burned).

Hemicellulose: A carbohydrate component of biomass, consisting of linked hexose and pentose sugars.

Hexose Sugar: A six-carbon sugar molecule.

High Heating Value: The quantity of heat released per unit mass of material oxidized (burned) in such a way that any water produced or released exits in the liquid state.

Hubbert's Peak: A peak in resource production, usually a peak in an energy resource, as predicted by logistic function modeling.

Hybrid Vehicle: A vehicle having more than one propulsion system and associated sources of energy.

Hydrocarbon: A chemical compound composed entirely of hydrogen and carbon.

Hydroelectricity: Electricity produced from flowing or falling water.

Hydroenergy: Energy extracted from flowing or falling water.

Hydrofracturing: A drilling technique in which pressurized water is pumped into underground rock formations to create permeability. See also Fracking.

Hydrogen: An element with one orbiting electron and either no neutrons (ordinary hydrogen), one neutron (deuterium or "heavy hydrogen") or two neutrons (tritium).

Hydrogenation: The process of adding hydrogen to a chemical compound.

Hydrolysis: A type of reaction involving water and a molecule that splits apart; one part combines with hydrogen from the water and the other part combines with a hydroxyl radical (OH).

Hydrothermal System: A geothermal system in which suitable rock formations and water supplies occur naturally.

Hydroxyl Radical: A combination of oxygen and hydrogen (OH) that exists in a chemical compound.

Insolation: A measure of the quantity of solar power received per unit of surface (typically watts per square meter or BTU per day per square foot).

Internal Combustion Engine: A type of heat engine in which fuel combustion occurs within the engine.

Ionic Bond: A chemical bond in which valence electrons are transferred from one atom to another.

Ionic Solution: A solution that contains free ions and is capable of conducting electricity.

Isomer: A term for compounds that have the same chemical composition but different molecular structures.

Isotope: A term for elements that have the same number of protons in their nuclei, but different numbers of neutrons.

Joule: A unit of energy in the SI system, equal to the work done by a force of one Newton when it moves an object a distance of one meter.

Karrick Process: A process for coal pyrolysis.

Kelvin (Temperature): A temperature scale in which the lowest possible temperature (absolute zero) is assigned a value of zero and the size of temperature increments is the same as in the Celsius scale.

Kerogen: A type of hydrocarbon found in oil shale.

Kerosene: A hydrocarbon fuel having 11 to 13 carbon atoms and approximately 2 hydrogen atoms per carbon atom.

Kilowatt: 1,000 watts.

Kinetic Energy: The energy of motion.

kW: Abbreviation for kilowatt. Also, kw.

Kyoto Protocol: An agreement between some of the nations of the world to limit greenhouse gas emissions (the protocol came into force in 2005).

Lanchester-Betz-Joukowski limit: The maximum energy extraction efficiency of a wind or water turbine (approximately 59 per cent).

Landfill Gas: Gas (mainly methane, carbon dioxide and water) produced anaerobically by microbes in landfills.

LED: Abbreviation for Light Emitting Diode.

Light Emitting Diode: A diode that emits light when a voltage is applied.

Lignin: The fibrous polymer that provides a plant's structural strength.

Lignite: A brownish coal that lies between peat and bituminous coal in the coalification process.

Lignocellulose: Plant matter composed of lignin, cellulose and hemicellulose.

Lipids: A broad group of naturally-occurring compounds, including some (such as fats and vegetable oils) that store energy and find application as a transportable energy source.

Liquefied Natural Gas: Natural gas that has been liquefied by reducing its temperature to -260°F .

Liquid Energy Ratio: The ratio of the energy in manufactured liquids to the energy in the liquids used in the manufacturing.

LNG: Abbreviation for liquefied natural gas.

Load-Following Power Plant: A power plant that changes production continuously to match demand.

Load Leveling: Actions taken to reduce variations in electrical power production and consumption.

Logistic Function: A sigmoid function commonly used in forecasting.

Low Heating Value: The quantity of heat released per unit mass of material oxidized (burned) in such a way that any water produced or released exits in the vapor state.

Megawatt: 1,000,000 watts.

Methane: A hydrocarbon that has the formula CH_4 and is gaseous at ordinary temperatures and pressures.

Methane Calthrate: A substance that consists of methane residing in a cage made of other molecules (typically water molecules).

Methane Hydrate: A methane calthrate in which water is the host molecule.

Methanogenic Bacteria: Bacteria that generate and release methane when digesting biomass.

Methanol: An alcohol (CH_3OH).

MKS: An abbreviation for meter, kilogram, second (units used in the SI system of measurement).

Moderator (Nuclear): Material used in a nuclear reactor to reduce neutron energy by scattering.

Momentum: The product of the mass of a moving object and the velocity of its motion.

Monosaccharide: A simple sugar having the general formula $(\text{CH}_2\text{O})_n$, where n is an integer greater than 2.

Motor (Electric): A device for converting electrical energy into mechanical energy.

MW: The abbreviation for megawatt.

Natural Gas: A mixture of methane, ethane, butane and pentane that is extracted from wells.

Natural Gas Liquid: Heavier hydrocarbons (butane and propane) that exist along with methane in natural gas and that can be liquefied with modest pressurization.

Natural Uranium: Naturally-occurring uranium (contains 99.3 percent U238 and 0.7 percent U235).

Neutron: A subatomic particle having no electric charge.

Newton: A measure of force in the SI system, equal to the amount of force required to accelerate a mass of one kilogram at a rate of one meter per second per second.

Nuclear Reactor: A device in which controlled nuclear reactions take place.

Nuclear Waste: Waste (generally radioactive) from nuclear processes.

Nucleus: The central part of an atom, consisting of protons and neutrons (except in the cases of ordinary hydrogen, which has no neutrons in its nucleus).

Ohm: A measure of electrical resistance.

Oil (Petroleum): A mixture of liquid hydrocarbons.

Oil (Vegetable): Liquid lipids derived from plants and composed of triglycerides.

Oil Sand (also called tar sand): Bitumen impregnated sand.

Open-Cycle Heat Engine: A heat engine in which the working fluid is expelled after use in the engine.

Passive Safety (Nuclear): Accident prevention or mitigation processes in a nuclear reactor that occur naturally and spontaneously.

Peak Oil: The rate of oil production at the time when production peaks.

Pentane: A hydrocarbon (C_5H_{12}).

Pentose Sugar: A five-carbon sugar molecule.

Permeability (Rock): The relative ability of openings in rock to permit the flow of liquids or gases under a pressure gradient.

Phantom Load: Energy consumption by appliances when in the standby mode.

Phase Change Air Conditioner: A cooling system that extracts heat from a region by evaporating a fluid.

Photolysis: The decomposition of chemical compounds by photon energy.

Photon: A packet of electromagnetic radiation.

Photosynthesis: The process by which plants use solar energy to produce sugars from carbon dioxide and water.

Photovoltaic: A term for the process of producing electricity by the capture of solar photons in a suitable semiconductor.

Plug-In Hybrid: A hybrid vehicle with batteries that can be recharged with grid electricity.

Polysaccharide: A carbohydrate consisting of linked sugar components.

Porosity (Rock): The percentage of open spaces within rock.

Potential Energy: The energy of position.

Power: The rate of energy flow.

Power Factor: The ratio of real power (usable power) to apparent power (volts times current) in alternating current. The ratio has a value of 1 when voltage and current are in phase and lower values when they are not in phase.

Primary Energy Consumption: User energy consumption plus the losses that occur in producing and delivering that quantity of energy.

Propane: A hydrocarbon (C₂H₆). Found in natural gas. Gaseous at normal temperature and pressure.

Proved Reserves: Estimated quantities of non-renewable energy sources that are recoverable under existing economic and operating conditions.

Pumped Storage (Hydroelectric): The pumping of water into an elevated reservoir for subsequent release through a turbine-generator when power is required.

Pyrolysis: The thermal disassembly of molecules in the absence of oxygen.

Quad: A unit of energy measurement used for large quantities of energy (equal to one quadrillion BTU).

R Value (Insulation): A measure of resistance to heat transfer through insulation, equal to the temperature drop across the insulation per unit of heat flux (typically temperature in degrees Fahrenheit and heat flux in BTU per square foot). Higher values of R indicate greater resistance to energy transfer.

Radiation (Thermal): Energy transfer by photons.

Radioactivity: The spontaneous emission of nuclear radiation from an atom.

Renewable Energy: Energy from sources that can be renewed continuously.

Replacement Rate (Population): The total fertility rate required for replacing an existing population under actual conditions.

Resistance (Electrical): A measure of a material's tendency to retard the flow of electricity (usually expressed in ohms).

Retorting: Heating a material in order to change its properties.

SEER: The abbreviation for Seasonal Energy Efficiency Ratio. A measure of air conditioner efficiency that is equal to the BTUs of heat removed in cooling during a typical cooling season, divided by the total electric energy input in watt-hours during the same period.

Shale Gas: Natural gas found in shale deposits.

Shale Oil: Kerogen impregnated rock.

SI Units: The abbreviation for Systeme International d'Unites, a measurement system based on meters for length, kilograms for mass and seconds for time.

Sigmoid Curve: An S-shaped curve that is thought to represent the general course of depletion of a non-renewable resource.

Sigmoid Function: The mathematical function that defines a sigmoid curve.

Solar Chimney: A solar energy system that uses the energy in heated air as it rises through a tall chimney.

Solar Constant: The average solar radiation energy reaching the earth's upper atmosphere (1353 watts per square meter).

Solar Tower: A solar energy system that uses focused sunlight to heat a working fluid.

Solvent Extraction: The separation of components in a mixture by exploiting differences in their solubilities in a solvent.

Sour Oil: High sulfur oil (oil with a high sulfur content).

Specific Heat Capacity: The quantity of heat required to raise the temperature of a unit quantity of matter by one degree. Typically expressed as calories per gram or BTUs per pound.

Specific Heat Capacity at Constant Pressure: The heat capacity of a compressible fluid when it is heated at constant pressure (heating causes the fluid to expand and thereby do work).

Specific Heat Capacity at Constant Volume: The heat capacity of a compressible fluid when it is heated at constant volume (heating causes no fluid expansion and therefore no work is done).

Starch: A carbohydrate composed of linked hexose sugars.

Steam Turbine: A system in which a pressure difference causes steam to flow over turbine blades to produce mechanical energy.

Stirling Engine: A heat engine that uses the external heating and cooling of a gas to produce mechanical energy.

Stover: Stalks and leaves of grain plants (see Corn Stover).

Stranded Gas: Natural gas located in deposits that are uneconomical to exploit because of limited capacity or difficulty in transporting.

Sucrose: A disaccharide of fructose and glucose, $C_{12}H_{22}O_{11}$.

Sugar (Simple): A monosaccharide with the general formula $(CH_2O)_n$ where n is greater than 2.

Sweet Oil: Low sulfur oil (oil with a low level of sulfur).

Syngas: A manufactured mixture of hydrogen and carbon monoxide.

Thermal Depolymerization: The disassembly of large polymer molecules by heating.

Thermal Efficiency: The ratio of the heat energy converted into a different and desired form of energy divided by the heat energy expended in the conversion.

Thermal Mass: Material used to store thermal energy during heat dumping or release thermal energy during heat extraction.

Thermochemical Process: A process that uses heat to enable and/or facilitate chemical reactions.

Tight Gas: Gas contained in unusually low-permeability deposits, usually hard rock or non-porous limestone.

Ton Mile: The product of the distance that freight is hauled and the weight of that freight.

Torque: The tendency of a force to rotate an object about its axis, equal to the product of the force and the perpendicular distance from the line of action of the force to the axis of rotation.

Transesterification: A type of chemical reaction between an alcohol and a triglyceride (an ester) to produce different esters.

Transformarian: A term for those who believe that energy production and consumption habits must change.

Transmission (Electric): The transport of electricity from power plants to distribution centers.

Triglycerides: Compounds with three fatty acid chains connected to a glycerol spine.

Trombe Wall: A south-facing wall located behind a glass window, used to capture solar energy.

Turbine: A device in which fluid flow causes blades mounted on a shaft to rotate.

U Value (Windows): A measure of heat transfer through windows, equal to the number of BTUs transferred per square foot of window per degree Fahrenheit temperature difference across the window. Low values of U indicate greater resistance to energy transfer.

Unconventional Gas or Oil: Gas or oil that is extracted from reservoirs in which additional operations besides simply penetrating the reservoir formation with a well are required.

U.S. Customary Units: Units in the foot, pound, second system of measurement.

Valence Electron: An electron in the outer shell of an atom.

Volt: A measure of electrical potential (the driving force that causes current to flow).

Waste Heat: Heat produced during the conversion of energy from one form to another.

Watt: A measure of power, equal to one Joule per second.

Wind Turbine: A device for producing mechanical energy by capturing wind energy

Work (Mechanical): The product of the force acting on a body and the distance of the resulting motion of the body in the direction of the force.

Zero Energy Building: A building that has a net absence of energy inputs from external sources.

Zero Energy Home: A residential zero energy building.

INDEX

A

abiogenic 87–88, 591
AC (alternating current) 158, 300–301, 346
actinides 240, 242, 247, 591
aerobic 172, 279, 418, 567
AFUE (annual fuel utilization efficiency)
330, 591
agriculture 10, 375, 577, 586
air conditioner 330–332, 537–538, 540–541,
545–547
efficiency 330–331, 439
air source (air conditioner or heat pump)
331–332, 539, 591
alcohol 28–29, 41–42, 48, 119–120, 122, 166,
172, 176, 179, 404, 549, 551, 565, 591
alternative energy 131, 373, 591
aluminum industry 584
ampere 31–32, 591
anaerobic 68, 108, 172, 182, 279, 567–568,
591
ANL (Argonne National Laboratory) 486,
493
annual fuel utilization efficiency (AFUE)
591
anode 592
anthracite 114, 485, 592
anthropogenic 72–73, 413, 416–417, 419–
420, 423, 425, 429, 431, 592
appliance (energy use) 323, 343–344, 346–
347, 351, 439–440, 446–447, 548
Argonne National Laboratory (ANL) 486,
493
ash 115–117, 119, 180, 428, 587
atom 33, 40–42, 44, 92, 121, 166, 169, 176–
177, 238–239, 273, 527–528, 549, 551, 555,
592

B

bacteria 278, 555, 592
barrel of oil 63, 592
base load 592
batteries 32, 45, 135, 159, 183, 244, 271, 284–
285, 299, 303, 385–386, 396–397, 401–405,
408, 468, 592
or fuel cells 396–397, 468
Bergius process 124, 592
biobutanol 185, 565, 592

biochemical processes 46, 166, 170, 182, 554,
592
biodiesel 174, 177–179, 182, 395, 468, 592
bioethanol 171, 182, 185, 553, 559–560, 563,
565
biofeedstock 592
biofuel 8–9, 15, 46, 48, 84, 131, 135, 163, 165–
170, 172–174, 177–179, 181–185, 293–294,
318, 378, 406, 467–469, 553, 559–564, 592
biogas 172, 182, 568, 592
biogenic 87–88
biohydrogen 593
biomass 8, 15, 46–48, 84, 86, 103, 106, 108,
119–120, 135–138, 165–169, 171–175, 177,
179–185, 271, 278–279, 293, 318, 374,
404–405, 422, 555, 559–561, 563–564,
566–567, 593
biomass-to-biofuel 167, 169, 181–182
biomethane 567, 593
bio-oil 175–176, 593
biophotolysis 279, 281, 593
biorefinery 593
biosynthesis 593
bitumen 102–104, 106, 593
bituminous (coal) 114, 117, 485, 583, 593
boiling water reactor 246, 255–257
Brazil 7, 556, 562
breeder reactor 10, 71, 243, 254, 261, 263, 593
fast 241, 258
British thermal unit (BTU) 19, 21, 23, 25, 29,
52–53, 58, 114, 133–134, 161, 168, 216,
225, 233, 266, 275, 330, 348–349, 377, 388,
436, 482, 486, 516, 547–548, 560–561, 577,
593
BTU (British thermal unit) 19, 21, 23, 25, 29,
52–53, 58, 114, 133–134, 161–162, 168,
216, 225, 233, 266, 275, 330, 348–349, 377,
388, 436, 482, 486, 516, 547–548, 560–561,
577, 593
butane 67, 85, 107, 294, 593
butanol 170, 172, 182, 279, 468, 486, 558,
565–566, 593

C

calorie 19, 21, 25, 29, 482, 593
calthrate 111, 594
CANDU reactor 239, 242, 258
cap-and-trade 426–427, 432, 594

-
- carbohydrate 28–29, 34, 46–47, 108, 166,
169–172, 278, 554, 557, 559, 563, 566, 594
- carbon 109
- carbon dioxide 8–9, 28–29, 45–48, 57, 72–73,
75–77, 83, 90, 108, 111, 113, 116–119, 126–
127, 135, 166–167, 172–174, 180, 230, 258,
267, 274, 276–278, 280, 379–380, 395–396,
404–405, 408, 413, 416–420, 422, 431,
466–467, 535, 553, 555, 563, 567–568
- carbon monoxide 28, 72, 108–109, 113, 117,
120–122, 175, 180, 276, 278, 486
- carbon sequestration 117, 594
- carboxyl group 176, 549
- carrier (energy) 15, 29, 34, 108–109, 271, 279,
282, 469, 528
- catalyst 44, 48, 91–92, 120, 122, 176, 555, 594
- CDD (cooling degree day) 329, 594–595
- cellulase 557, 594
- cellulose 165, 169–172, 179, 182, 185, 348,
554, 557–558, 566, 594
- Celsius 19, 25, 27, 594
- cement industry 582
- CFL (compact fluorescent lamp) 343, 352,
449, 594–595
- chemical
- bonds 34
 - energy 23, 28, 32, 34, 37, 45–46, 48, 137,
165, 271, 285, 396, 401, 468, 563
 - industry 67, 371, 374, 376, 579
 - processes 46, 87, 122, 166, 176, 182
 - separations 42
- Chernobyl 237, 241, 245, 258–259
- chlorophyll 47, 594
- coal 8, 34, 57, 60–61, 63, 69–72, 74–76, 83–84,
86, 102, 104, 108, 110–111, 113–119, 121,
124, 127, 277–278, 291–292, 304–305,
318, 373, 375, 378, 428–429, 466, 469, 485,
560–561, 567, 577, 582–583, 587, 595
- combustion 70, 77, 115–117, 485
 - reserves 70, 113, 117
- coalification 113–114, 595
- cogeneration 378–379, 445
- coke 66, 113, 116–117, 373, 379, 583, 595
- commercial energy use 357–358, 360, 363,
367
- compact fluorescent lamp (CFL) 343, 352,
449, 594–595
- condenser 53, 256–257, 334, 538–539, 541,
545–546, 595
- conduction (heat) 27, 231, 348–349, 497–
498, 595
- conservation (of energy) 5, 17, 266, 317, 330,
363, 379, 426, 435–436, 438, 442, 448, 465,
595
- convection (heat) 27, 348, 595
- conventional gas 67, 109–111
- conventional gas or oil 595
- cooling degree day (CDD) 329, 594–595
- corn stover 559, 595
- cornucopians 5–6, 595
- covalent bonds (chemical) 41, 527, 596
- cracking (oil) 91, 104, 107, 120, 123, 596
- current (electrical) 29–32, 45, 53, 157–158,
279, 297, 300–301, 346, 527–529, 543, 596
- ## D
- dams 10, 135, 203, 206–207, 213–214, 429,
468, 569
- Darrieus wind turbine 195
- DC (direct current) 32, 45, 158, 300, 346
- delivered energy 62, 325–329, 340, 342, 357–
360, 364, 373–377, 437, 577–580, 584,
586–587, 596
- demographic transition 314, 596
- Department of Energy (DOE) 50, 58, 99,
147, 220, 287, 302, 326, 341, 344, 349–350,
357, 364, 374, 402, 437, 442, 444, 493–494,
547–548
- deuterium 239, 264
- diesel engine 123, 177–178, 395–396, 405,
596
- diffusion 275, 596
- dimethyl ether 122–123, 181, 183, 186, 596
- dimethylfuran 179, 596
- diode 157, 529, 596
- direct current (DC) 32, 45, 158, 300, 346
- disaccharide 169, 554–556, 596
- distillate fuel oil 66, 596
- distillation 42–43, 91, 171, 554, 597
- distribution (electric) 72, 283, 291, 300, 302,
327, 376, 397, 406, 448, 597
- district heat 597
- DOE (Department of Energy) 50, 58, 99,
147, 220, 287, 302, 326, 341, 344, 349–350,
357, 364, 374, 402, 437, 442, 444, 493–494,
547–548
- dopant 157, 528
- dry weight 597
- ## E
- earth cooling tube 333, 597
- economics 298, 455, 457–458, 460
-

-
- EERE (Energy Efficiency and Renewable Energy) 493
- efficiency (thermal) 387, 597
- EIA (Energy Information Administration) 50, 58, 61–63, 65–66, 69, 73–74, 94, 99, 357–358, 493
- EIA oil forecasting 97, 499
- electric vehicle 285, 385, 396, 398, 402–403, 444
- electrical
- energy 7, 10, 15, 29, 31–32, 34, 37, 45–46, 57, 71–72, 77, 135, 155, 157, 191, 198, 208, 213–214, 225–226, 228, 281, 283–286, 298, 301–302, 325–326, 328, 334, 346, 358, 363, 373, 376, 381, 398–399, 401, 405, 436, 527, 543, 547, 569, 575, 583
 - frequency 301
 - generator 159, 212, 256, 346
 - losses 597
 - resistance 300
- electricity 6–7, 9, 15, 29–32, 37, 45, 52–53, 70–72, 76, 83, 104, 108, 113–115, 124, 132, 134–138, 143, 154, 156, 158–160, 162, 183, 189, 193, 196–200, 203–204, 206, 208–209, 212–215, 223–226, 237, 244, 251, 254–255, 258, 260, 265, 267, 271–272, 274, 279–281, 283–286, 292, 295–297, 299, 301–304, 323, 325–328, 331, 333–334, 343, 345–347, 351–352, 357, 359, 366, 374, 378, 385–386, 395–396, 398, 401–402, 404–406, 447–448, 467–470, 538, 541, 560–561, 569, 585, 588
- distribution 72, 283, 291, 300, 302, 327, 376, 397, 406, 448
 - transmission 227, 300, 397
 - transport 297–298
- electrochemistry 45, 597
- electrolysis 7, 33–34, 45–46, 196, 260, 271, 276, 279–281, 283, 285, 296, 380, 404, 597
- electrolyte 279, 597
- electromagnetic energy 19, 32, 34, 46, 48
- electron 29, 33, 41, 157, 273, 527–529, 534, 598
- shell 41, 527–528
- embodied energy 436, 598
- energy 598
- balance 39–40, 423, 559–560, 598
 - carrier 598
 - consumption (U.S.) 10, 58–59, 61–62, 191, 301, 304, 324–326, 328, 340–341, 346–347, 349–350, 352, 357–358, 360–365, 371–372, 374–377, 380, 387, 391, 435–436, 446–447, 455–457, 465, 577, 579, 586–587
 - consumption (world) 10, 57–60, 304, 317–318, 320, 324–326, 328, 341, 346–347, 349–350, 352, 358, 360–364, 374, 380, 435, 465–466, 577, 579, 586–587
 - efficiency 37, 272, 285, 330, 343–344, 350, 352, 362, 372, 377, 388–389, 404, 426, 435, 439–440, 443–446, 465, 559–561
 - efficiency ratio 547
 - production (U.S.) 5–6, 8, 16, 20, 24, 47, 52, 57–59, 61, 63, 72, 76, 138–139, 167, 172, 181, 198, 215, 223, 225, 230, 241, 254, 262, 277, 286, 317, 325–326, 328, 341, 352, 374, 414, 419, 426–427, 456, 458, 465, 566, 573
 - production (world) 5–6, 8, 16, 20, 24, 47, 52, 57–59, 72, 76, 138–139, 172, 181, 215, 225, 230, 241, 254, 262, 277, 286, 317, 325, 352, 374, 414, 419, 426–427, 456–458, 566, 573
 - ratio 39–40, 598
 - transport 16, 34, 139, 291, 303–304, 469–470
- energy carrier 15, 29, 34, 108–109, 271, 279, 282, 469, 528
- energy conservation 5, 17, 266, 317, 330, 363, 379, 426, 435–436, 438, 442, 448, 465
- Energy Efficiency and Renewable Energy (EERE) 493
- ENERGY GUIDE 344
- Energy Information Administration (EIA) 50, 58, 61–63, 65–66, 69, 73–74, 94, 99, 357–358, 493
- ENERGY STAR 330, 344, 548, 598
- energy use
- commercial 357–358, 360, 363, 367
 - industrial 371–372, 374
 - residential 147, 325–326, 350, 436
 - transportation 387, 391, 406, 442
- engineered geothermal systems 222, 233
- engines 35, 598
- heat 35–39, 132, 135, 137, 143, 154, 156, 160, 178, 286, 467, 514, 517
 - internal combustion 35–36, 385–386, 393, 396, 398–400, 402–404, 562
 - jet 36–37, 379, 395
 - Stirling 35–37, 135, 154–155, 487–490
-

- enhanced geothermal systems 219, 222–224, 227, 230, 232, 598
- enzyme 48, 166, 171–172, 185, 279, 555–558, 566, 598
- esters 28, 166, 176, 549, 551
- ethane 67, 85, 107, 486, 598
- ethanol 7, 122, 165, 170–173, 177, 179–180, 182, 185, 279, 291, 294, 468, 486, 551, 553–558, 560–566, 598
- ethers 28, 166, 599
- evaporative coolers 332, 543, 599
- evaporator 333–334, 538–539, 541, 545, 547, 599
- exajoule 21, 599
- F**
- Fahrenheit 19, 25, 27, 599
- fast breeder reactor 241, 258
- fast reactors 255
- fermentation 120, 165, 170–171, 173, 179, 182, 278–279, 554–555, 558, 599
- fertile material 240, 242
- fertility rate 315–316, 599, 610
- Fischer-Tropsch process 122–123, 180, 182–183, 599
- fissile material 240, 242–243, 263, 599
- fission 8, 10, 33–34, 71, 131, 214, 237–241, 243–245, 253–254, 263, 272, 469, 599
- gamma rays 240, 242
 - neutrons 241
 - products 239–240, 242, 246–247, 261, 600
- fissionable material 600
- food industry 578
- food miles 389, 600
- force 16–17, 23, 28–29, 31, 194, 473–476, 570, 597, 600
- fossil fuel 5–9, 57, 67, 71–72, 75–76, 83–85, 103, 112, 120, 124, 131, 135–136, 138, 173, 175, 197, 208, 238, 251, 262, 265, 272, 276, 278, 297, 373, 393, 397, 404–405, 413–414, 419, 421–422, 428–429, 465, 467, 538, 559–561, 567, 600
- fracking 57, 77, 83–84, 90, 600
- fractional distillation 43, 600
- France 7, 18, 213, 252, 456, 476
- freight energy intensity 600
- freight hauling (energy efficiency) 600
- fuel cells 108, 271, 284, 287, 404, 468, 600
- vs. batteries 45, 285, 385–386, 396–397
- fungus 600
- furnace 117, 181, 330, 334, 373, 379, 424, 440, 445, 582–583
- efficiency 330
- fusion 7–8, 26, 33–34, 131, 263–265, 600, 602
- reactors 10, 33, 238, 265, 469
- futilitarians 5, 601
- G**
- gamma rays 33, 599
- gas absorption refrigeration 137, 601
- gas compression 135, 404, 601
- gas turbine 35–36, 71, 117, 240, 298, 395–396, 601
- gas-cooled reactor 240, 255, 258, 261
- gasification 120, 174–175, 182–183, 278, 601
- gasoline 29, 66, 86, 92, 170, 172, 179, 181, 183, 284, 293, 393, 395–397, 402, 405, 486, 562–563, 565, 601
- generator (electrical) 159, 212, 256, 346, 601
- geothermal 7, 9–10, 33, 196, 208, 219, 223–225, 227–228, 230, 280, 297, 323, 469, 547, 598, 601
- energy 9, 131, 138, 220, 222–224, 227, 230, 232, 467–468, 494, 598
 - gradient 221–222, 601
 - heat pump 219, 232, 334–335, 363, 601
- glass industry 581
- global warming 8, 76, 413, 416, 418–420, 422, 425–429, 535, 563, 567–568, 601
- glucose 556–558, 601
- government 6–7, 50–51, 61, 250, 254, 263, 324, 343–344, 351–352, 358, 362, 373, 380, 393, 406, 425–426, 435, 445–447, 455, 459–460, 470, 493
- gravitational constant 204, 569
- gravity 18, 23, 189, 473–476
- greenhouse effect 136, 251, 336, 414, 416, 419–420, 423, 508, 567, 602
- greenhouse gases 72, 213, 378, 416–417, 419, 424–426, 602
- ground effect heat pump 440–441
- H**
- HDD (heating degree days) 150, 329, 602
- heat
- capacity 25, 152, 225–226, 337, 611
 - conduction 27, 231, 348–349, 497–498
 - convection 27, 348
 - dumping 334, 336, 602, 612
 - of fusion 26, 602
 - of vaporization 25, 602

-
- pump 219–220, 231–232, 323, 330–335, 341–342, 352, 363, 440–441, 537, 539, 545, 547–548, 601–602
- radiation 27, 32–33, 132, 134, 136–137, 143–144, 146, 149, 156, 220, 239–240, 265, 336, 350, 413–416, 419, 422, 424, 507–509, 513–514, 516, 519–520, 524, 531, 533–534, 610
- sink 156, 219–220, 232, 333, 546–547
- transfer 27, 144–145, 156, 219, 225, 230–231, 283, 331, 333, 337, 340–341, 348–350, 377, 469, 545
- heat engine 35–39, 132, 135, 137, 143, 154, 156, 160, 178, 286, 467, 514, 517, 602
- heating degree days (HDD) 150, 329, 602
- heating value 28–29, 109, 122, 179, 274, 485–486, 568, 603
- heavy water reactors 239, 241, 258
- hemicellulose 165, 169–172, 179, 182, 554, 557–558, 566, 603
- hexose 47, 169–170, 555, 558, 603
- high heating value 29, 68, 86, 108–109, 175, 274–275, 485, 553, 565, 567, 603
- Hubbert (forecasting) 83, 96–101, 497, 502, 504, 506, 603
- hybrid vehicle 303, 397–399, 401–402, 405, 603, 609
- hydrocarbons 28–29, 34, 48, 61, 66, 75, 83–86, 91, 103–104, 107–108, 112–113, 116, 119–120, 122–124, 165–166, 168, 170, 172–173, 176, 181–183, 271, 277–278, 294–295, 312, 371, 388, 404, 429, 486, 551, 603
- hydroelectricity 71, 603
- hydroenergy 9, 131, 135, 137–138, 203, 208, 213–214, 280, 297, 467–468, 603
- hydrofracturing 57, 68–69, 74, 83, 90–91, 110, 224, 232, 376, 429, 603
- hydrogen 7, 15, 28, 34, 40, 45–46, 48, 83–85, 109, 112–114, 117, 119–120, 136, 165, 169–170, 173, 175, 180, 182–183, 239, 244, 260, 271, 273–279, 281–286, 291, 296–297, 397, 404, 469, 485–486, 541, 549, 551, 554, 566, 603
- as a fuel 109, 272, 284
- production 121–122, 160, 179, 196, 246, 271–272, 276, 278–279, 283, 285, 296–297, 299, 397, 404, 561
- storage 282–284
- to carbon ratio 86, 92, 103–104, 106, 120, 123, 176
- transport 283, 296–297
- use (energy efficiency) 34, 272
- hydrogenation 92, 104, 107, 123–124, 183, 603
- hydrolysis 169, 171–172, 179, 182, 279, 281, 397, 554, 556–558, 566, 604
- hydrothermal energy 604
- hydroxyl radical 48, 604
- I**
- Iceland 7
- industrial energy use 371–372, 374
- insolation 156, 340, 342, 346, 604
- insulation 144, 147, 152, 323, 345, 347–349, 351, 377, 440, 444, 610
- intermittency 143, 159–161, 189, 196, 199, 297, 299
- internal combustion engine 35–36, 385–386, 393, 396, 398–400, 402–404, 562, 604
- ionic bonds (chemical) 41, 604
- ionic solution 604
- isobutane 85, 107
- isomer 41–42, 67, 85, 604
- isotope 44, 238–240, 242, 252, 264, 420, 604
- J**
- jet engine 36–37, 379, 395
- Joule 19, 21, 24, 300, 334, 344, 473, 604
- K**
- Karrick process 124, 604
- Kelvin (temperature) 28, 531, 533, 546, 604
- kerogen 102–103, 106, 605
- kilowatt 210, 483, 573, 605
- kilowatt hour 52, 198, 214, 286, 482
- kinetic energy 22–23, 33, 37, 135, 138, 189, 204, 209, 213, 240, 263, 386, 468, 476–477, 569, 571, 575, 605
- Kyoto Protocol 426–427, 605
- L**
- Lanchester-Betz-Joukowski limit 210, 605
- landfill gas 605
- LED (light-emitting diode) 343, 605
- light emitting diode (LED) 343, 605
- light water reactors 71, 241, 258, 261
- lignin 165, 169–170, 172, 181, 557–559, 566, 605
- lignite 114, 605
- lignocellulose 605
- lipids 176, 605
- liquefied natural gas (LNG) 606
- liquid energy ratio 40, 606
-

liquid lead fast reactor 261
 liquid sodium fast reactor 261
 LNG (liquefied natural gas) 606
 load following 196–197, 606
 load leveling 284, 299, 303, 606
 logistic function 95, 314, 498–499, 606
 low heating value 29, 68, 108, 274–275, 485,
 553, 565, 567, 606

M

magnetic field 30, 32, 37
 manufacturing 160, 193, 371, 373–375, 377,
 543, 559, 563, 577, 585–586
 mass 16–19, 22, 24–25, 29, 33, 204, 239–240,
 263, 283, 323, 336–337, 340, 403, 441,
 473–477, 480, 569–573
 mechanical energy 15, 19, 22, 33, 35, 38, 189,
 212, 231, 284, 324, 346, 386, 395–396, 401,
 404, 538–539, 541, 546, 563, 575
 megawatt 482–483, 606
 methane 67–68, 85, 107–112, 114, 120–124,
 170, 172, 175, 182, 273–277, 416, 419, 467,
 486, 567–568, 606
 methane calthrate 111, 594, 606
 methane hydrate 109, 111, 594, 606
 methanogenic bacteria 606
 methanol 122–123, 179–181, 183, 404, 486,
 551, 606
 metric ton 59, 71, 262, 480
 million tonnes of oil equivalent (MTOE)
 20–21, 59, 482
 mining 70, 103–107, 110, 115, 117–118, 248,
 263, 292, 371, 373–375, 429, 466, 577, 587
 Mobil M-gas process 181
 moderator (nuclear) 239–241, 243, 245, 258,
 607
 molecular structure 41–42, 85, 111, 122, 273,
 553
 molecules 28, 41, 44, 46, 85–86, 91, 104, 111,
 114, 120–121, 123, 165–166, 169–170,
 175–177, 276, 281, 296, 551, 556, 559, 581
 molten salt reactor 242, 255
 momentum 37, 490, 607
 monosaccharides 169, 171, 554–555, 607
 motor 35, 37, 231, 386, 396–402, 404–405,
 445, 607
 MTOE (million tonnes of oil equivalent)
 20–21, 59, 482

N

National Renewable Energy Laboratory
 (NREL) 51, 158, 364, 493, 515, 520, 559
 natural gas 8, 60–61, 67, 69, 71–72, 74, 76, 83–
 84, 92, 123–124, 197, 285, 294, 323, 328,
 357, 373, 376, 466, 486, 560, 578–579, 581,
 588, 607
 drilling 90, 110, 429
 liquid 63, 291, 295, 606–607
 properties 68, 107–108
 reserves 57, 67, 69, 75, 83, 112, 466
 storage 297, 405
 natural uranium 238–239, 252, 258, 262, 607
 neutron 40, 44, 238–244, 247, 252–253, 259,
 263–265, 420, 607
 Newton 19, 473, 476, 607
 Newton's Second Law 16, 474–475
 NREL (National Renewable Energy Labora-
 tory) 51, 158, 364, 493, 515, 520, 559
 N-type semiconductor 528–529
 nuclear
 accidents 249–250
 energy 8, 10, 33, 35, 73, 118, 131, 237–
 265, 426, 467, 563
 fuel reserves 73, 238, 262
 proliferation 252, 260, 265
 reactor 8, 44, 237, 253–254, 260, 262,
 281, 429, 469, 607
 generations 253
 reserves 74
 safety 8, 10, 243
 waste 10, 237, 243, 248, 607
 weapons 237, 252–253
 nucleus 29, 40–41, 44, 238–240, 263–264,
 273, 420, 527, 608

O

Oak Ridge National Laboratory 493
 ocean current energy 132, 135, 203–204, 209,
 211, 468
 ohm 31, 608
 oil 8, 21, 50, 57, 60–61, 63, 65–66, 69, 74–75,
 83–84, 86–94, 96–98, 102–107, 110, 112,
 119, 124, 165, 168, 172, 183, 223–224,
 291–293, 314, 317, 328, 330, 375, 428,
 465–466, 482, 486, 497–498, 504, 559, 577,
 581, 588, 608
 formation 87, 89–90
 refining 86, 276, 294, 296, 585
 reserves 84, 91, 93, 101
 sands 66, 74–75, 83–84, 103–104, 119,
 124, 278, 293, 466, 608

- shale 57, 66, 74–75, 83–84, 102, 105–107, 119, 124, 278, 293, 466
vegetable 170, 176–178, 181–183, 549, 551, 608
open-cycle heat engine 37, 608
orimulsion 104
- P**
Pacific Northwest National Laboratory (PNNL) 190
paper industry 579
passive safety (nuclear) 259, 608
peak oil 94, 97, 608
Peltier 537
pentose 169–170, 555, 608
permeability (rock) 109–111, 219, 222–224, 608
phantom load 346, 439, 608
phase change air conditioner 608
photoelectric effect 33, 143, 527
photolysis 608
photon 32–33, 47, 143–144, 154, 157, 414, 424, 507, 513, 527–529, 533–536, 609
photon absorption 143, 416, 420, 533
photosynthesis 15, 46–47, 132, 135–136, 165–167, 182, 278, 422, 468, 507, 555, 563, 567, 609
photovoltaic 132, 137, 143, 154, 156–160, 281, 303, 318, 324, 346–347, 364, 397, 444, 507, 519, 527, 609
pipelines
 ethanol 291, 294, 469, 563, 565
 hydrogen 296, 469
 natural gas 67, 69, 294–296, 373, 466
 oil 293, 387–388
Planck's Law 531–532
plug-in hybrid vehicle 303, 401–402, 405, 609
plutonium 8, 240, 242, 247–248, 252
PNNL (Pacific Northwest National Laboratory) 190
pollution 70, 72, 105, 118, 227, 230, 286, 292, 378, 396, 398, 428, 448, 466, 564
polysaccharides 169, 555, 609
population
 and energy 311–319, 457
 estimates 316–317
 growth 311, 313–315, 319
 stabilization 314–315
 U.S. 61, 312–313
 world 10, 311–312, 314, 316–317, 319, 455–457
population growth 406, 455, 498
porosity (rock) 111, 222, 609
Portugal 7
potential energy 22–24, 105, 124, 138, 178, 204, 213, 364, 386–387, 474, 476, 569–570, 609
power 17, 19–20, 31, 61, 71, 108, 117, 156, 159, 191–193, 196–197, 204–208, 210–211, 220–221, 223–224, 226–227, 243–244, 249, 251, 254, 262, 265, 298–303, 341, 347, 374, 393, 395, 397–398, 401, 405, 468, 483, 514, 569–570, 574–575, 609
 electrical 7, 31, 67, 69–70, 115, 189, 205–206, 246, 297, 396, 398, 402, 597
power factor 297, 301, 609
pressurized water reactor 247, 254–256
primary energy 62, 318, 325–328, 343, 357–358, 360, 372, 374, 376, 437, 609
propane 67, 85, 107, 291, 294–296, 328, 330, 405, 486, 609
proton 40, 44, 239, 264, 273, 420, 527–528
proved reserves 67, 69, 74, 112, 609
P-type semiconductor 528–529
pumped storage 160, 208, 299, 609
pyrolysis 120, 124, 174–176, 182, 610
- Q**
quad 21, 58, 71, 131–132, 134, 156, 159, 167–168, 178, 189, 198, 610
- R**
R value (insulation) 348–349, 610
radiation
 nuclear 239–240, 265, 531, 533, 610
 thermal 27, 32, 132, 134, 136–138, 143–144, 146, 149, 156, 336, 350, 413–414, 416, 419, 422–423, 507–509, 512–514, 516, 519–520, 610
radioactivity 44, 219, 241, 243, 247–248, 610
Rankine (temperature) 28, 546
RBMK reactor 241, 245, 258
refrigeration 137, 143, 325, 327, 331, 359, 545–546, 580, 599
renewable energy 5, 15, 62, 68, 108, 131, 136, 138, 208, 507, 516, 610
replacement rate (population) 315–316, 610
residential energy use 147, 325–326, 350, 436
resistance
 electrical 31, 300, 608, 610
 thermal 348–349, 610
retorting 120, 610

river current energy 211, 468

S

Savonius wind turbine 193
 seasonal energy efficiency ratio (SEER) 330, 547, 610
 SEER (seasonal energy efficiency ratio) 330, 547, 610
 semiconductor 157, 527
 shale gas 109–110, 376, 610
 shale, oil 57, 66, 74–75, 83–84, 102, 105–107, 119, 124, 278, 293, 466, 610
 SI units 19, 25, 473, 611
 Sigmoid curve 498, 611
 Sigmoid function 498–499, 611
 silicon 157, 527–528, 583
 slag 116, 119
 smart grid 291, 302–303, 469
 solar
 cell 7, 33, 134–135, 527
 chimney 159, 611
 constant 507, 509, 511, 513, 611
 cooling 153
 energy absorption 131–134, 147, 423, 519, 522–523
 heat engine 37, 132, 135, 137, 143, 154, 156, 159–160, 467
 panel 153
 photovoltaic 158, 303
 pool heating 145, 152–153
 power tower 154–155, 159, 193, 611
 space heating 132, 134, 144–145, 149
 spectrum 136, 415, 508, 532
 water heating 132, 134, 137, 144–146, 149–150, 342
 solar collector 137, 144–147, 153, 155, 352, 467, 508, 519–520
 aiming 523
 concave 154, 194
 dual axis tracking 520, 523
 horizontal 148, 342, 346, 519, 521, 523
 single axis tracking 520, 523–524
 vertical 192, 521, 523
 solvent extraction 42, 44, 90, 557, 611
 sour oil 92, 611
 specific heat capacity 25, 225, 337, 611
 spectrum
 earth emission 137, 415–416, 507, 532
 solar 136, 414–416, 507–508, 532
 starch 165, 169–172, 554, 557–558, 561, 566, 612

steam 35–38, 71–72, 90, 117, 120, 124, 154, 180, 214, 219, 223–225, 227–228, 240, 256–257, 276, 377, 404, 581
 superheated 26
 turbine 35, 37, 612
 steel industry 583–584
 Stephan-Boltzmann Equation 532
 Stirling engine 35–37, 135, 154–155, 487–490, 612
 stored energy 23, 34, 137, 159, 166, 221, 223–224, 299, 303, 386, 403, 468, 559
 stover 559, 595, 612
 stranded gas 67, 295, 612
 sucrose 554, 556, 558, 612
 superheated steam 26
 sustainable energy 5, 9, 124, 272, 455, 468
 swamp coolers 332
 sweet oil 92, 612
 syngas 113, 116–117, 120–123, 175, 179–180, 182–183, 276–278, 612

T

temperature scales 28, 594, 599, 604
 thermal depolymerization 120, 612
 thermal efficiency 387, 612
 thermal energy 15, 19, 24, 27–28, 33, 38, 71, 74, 225, 244, 318, 378, 537
 thermal mass 323, 336–337, 340, 441, 612
 thermal resistance 300, 345, 348–349
 thermochemical process 612
 thorium 116, 242, 247–248
 Three Mile Island 237, 241, 246, 259
 tidal energy 131, 138, 468
 tight gas 109–110, 613
 ton mile 185, 613
 torque 396–397, 405, 613
 transesterification 177, 182, 549, 551, 613
 transformarians 5–6, 465, 613
 transmission (electrical) 72, 197, 199, 211, 227, 283, 291–292, 294, 300–302, 325, 376, 386, 397, 399, 404–405, 447, 468, 613
 transportation 7, 9, 62–63, 69, 72–73, 76, 83, 87, 106, 112–113, 119, 124, 135, 167–168, 178, 183–184, 272–273, 324, 352, 371, 378, 385, 387–388, 390–392, 395–398, 405–406, 442–443, 446–447, 468, 562–563, 585
 transportation energy use 387, 391, 406, 442
 triglycerides 47–48, 168, 173, 176–177, 182–183, 549, 551, 613
 Trombe wall 336–337, 441, 613

turbine 9, 35–38, 71–72, 117, 135, 137–138, 154, 159, 189, 191, 193–195, 198–199, 204–210, 212, 214, 224, 227–228, 230, 240, 256–257, 284, 298, 301, 303, 324, 346, 395–396, 467–468, 569, 571, 574–575, 601, 612–614

U

U value (windows) 613
U.S. customary units 19, 25, 476–477, 614
unconventional gas or oil 613
uranium 8, 71, 74–75, 116, 131, 238–240, 242, 247–248, 251–253, 256–258, 262–263, 561, 607
uranium consumption 70
uranium reserves 10, 71

V

valence electron 41, 528, 614
vehicle production (U.S.) 385, 390–391
vehicle production (world) 390–391
vehicle registrations (world) 391–392
very high temperature reactor (VHTR) 261
VHTR reactor (very high temperature reactor) 261
volt 31, 614
voltage 29, 31–32, 45, 297, 300–301, 543–544
VVER reactor 258

W

waste heat 37, 72, 237, 251, 281, 387, 393, 543, 614
water shift reaction 117, 121, 277–278
watt 19, 318, 330, 343, 401–403, 473, 482, 547–548, 614
wave energy 211, 468
web sites 158, 362, 493
weight 18–19, 24, 29, 102–104, 120, 165, 226, 272, 274, 282, 284, 387, 396–397, 401, 473–476, 480, 558, 570, 572, 597
wind 7, 9, 17, 131–132, 135, 189–199, 208–209, 211, 280, 297, 299, 318, 324, 346, 378, 387, 467–468, 569, 571, 575, 614
wind power 191–192, 196–197, 298, 470
wind turbine
 Darrieus 193–195
 horizontal axis 192–194, 196
 Savonius 193
 siting 197, 199
 vertical axis 192–194, 196, 524
work 614

Z

zero energy building 364, 614
zero energy home 351, 614

