



# An Article on Optimal Heat Extraction for Clean Geothermal Power Generation using Graphene Wire

Md. Zubaer Mahmud Rony<sup>1</sup>, Engr. S M Anowarul Haque<sup>2</sup>, Md. Mostakim Rahman<sup>3</sup>, Nurun Nahar<sup>4</sup>

<sup>1</sup>Physics Teacher, Kids Campus School  
Dhaka, Bangladesh,  
[md.zubaer.mahmud.rony@gmail.com](mailto:md.zubaer.mahmud.rony@gmail.com)

<sup>2</sup>Assistant Professor, Mymensingh Engineering College  
Mymensingh, Bangladesh,  
[enr.sonet2017@gmail.com](mailto:enr.sonet2017@gmail.com)

<sup>3</sup>BSc. in EEE Student, Mymensingh Engineering College  
Mymensingh, Bangladesh,  
[mostakim.mec.eee@gmail.com](mailto:mostakim.mec.eee@gmail.com)

<sup>4</sup>BSc. in EEE Student, Mymensingh Engineering College  
Mymensingh, Bangladesh,  
[junejuly0203@gmail.com](mailto:junejuly0203@gmail.com)

**Abstract:** Renewable power generation is rapidly growing because of the depletion of fossil fuels. To improve the power crisis of the world geothermal energy can be a vital substitute. Geothermal energy is a form of renewable sources such as wind, solar and biomass. More notably, because of its lower emissions of greenhouse gas, geothermal energy is effective in reducing catastrophic environmental retrogression. Till now geothermal energy is being generated by exploiting the hot water from underground. Despite having a low rate of contamination, underground water does bring up a small portion of pollutants. Geothermal plants are not available worldwide due to the high risk of earthquakes as the injection of hydrothermal fluids can cause fractures in large rocks underground. To avoid this problem graphene can be implemented as a heat conductor. A long thick wire of graphene can bring up heat from underground heat sources, thus, excluding the greenhouse gas emissions and the risk of an earthquake. Graphene is a superconductor of heat, has a melting point much higher than we require, and is the strongest conductor of heat ever discovered. This will replace the water injection process and completely avoid the modern problems faced by geothermal power generation.

**Keyword:** Fossil Fuels, Geothermal Energy, Graphene, Superconductor.

(Article history: Received: 18<sup>th</sup> January 2021 and accepted 27<sup>th</sup> August 2021)

## I. INTRODUCTION

Renewable Energy Resources are the most important element in the sustainable industrialization of a country [1]. Geothermal energy is one of the distinguished renewable resources had an impact on electric power generation throughout the past decade. Most of the other renewable resources such as solar, wind, and hydropower are unpredictable and unreliable. On the other hand, geothermal power is predictable and reliable or compatible [2]. Therefore, geothermal power plants have the potential to operate as baseload power plants [3]. Geothermal energy can be used as a compatible indemnity for the irregular nature of other renewable resources since geothermal energy is consistent. The basic concept of geothermal power generation is simple and reliable. It is based on the conversion of the earth's internal thermal energy to electric energy. Water or hydrothermal fluid is pumped deep into the earth through injection wells. That water is used to produce pressurized steam which will be stroked on turbine blades [7]. Though this process is an effective way to get access to the heat underground, it also has its drawbacks. Hot water

pumped from underground reservoirs often contains high levels of sulfur, salt, and other minerals.

Although the process is a closed-loop system the pipes are needed to be changed after some time [4].

This research presents a study of geothermal power generation where the heat from underground sources will be brought up by a material called graphene. Strings of graphene can be turned into a wire and that wire can be placed as a pillar underground which will bring up only the heat. Graphene is a superconductor of heat and has a melting point of 3650°C [5].

So, it will not melt in extreme temperatures as other heat-conducting metals. Graphene is also the strongest material ever discovered with a tensile strength of 130 gigapascals [6]. So, it will also be able to take the enormous pressure of the ground around it. As only the heat will transfer through the material, no greenhouse gases or chemicals can come up from underground, thus, ensuring clean energy.

In the paper the section I presents an introduction, section II presents current concepts on electrical power generation

using geothermal energy. Section III states the implementation of graphene in geothermal heat extraction. Then, section IV shows the simulation of heat transfer through a graphene wire. Section V discusses the global geothermal energy state and finally, section VI states the concluding remarks.

## II. PRESENT STATE OF GEOTHERMAL POWER GENERATION

### A. Operating Concept of Geothermal Power Plant

Geothermal energy is the thermal energy stored under the earth's crust [7]. There is a magma layer under the earth's crust where thermal energy is continuously produced due to the decay of naturally radioactive materials such as Uranium [7]. According to [7] the amount of thermal energy within 10,000 meters of the earth's surface contains 50,000 times more energy than all petroleum and natural gas resources in the world.

The magma layer under the earth's crust contains thermal energy. Water or hydrothermal fluid [7] is pumped deep into the earth through injection wells. In this process, water is used to extract the heat from underground. As the water absorbs heat when it has been injected underground its temperature increases. This hot water is used to produce steam and that steam is supplied through a nozzle and strikes the turbine's blades. The thermal energy from the steam is converted to the kinetic energy of the turbine. The turbine is coupled with a generator's rotor. The generator is used to convert the kinetic energy into electrical energy. The procedures change depending on the class of power plants. There are three classes of geothermal plants are used in the current context. These three types are dry steam power plants, flash steam power plants, and binary cycle power plants [7]. These different techniques are to be used in different geographical locations depending on the availability of resources. These three types are described in the following sub-sections.

### B. Geothermal Power Plants' Classification

1) *Dry Steam Power Plant*: Dry steam power plants use hydrothermal fluids [7], [8] which mainly consists of steam. Figure 1 shows a schematic diagram of a dry steam power plant. The term hydrothermal fluid is used because chemical elements and gases are mixed in the water [8]. The water is injected into the injection well and sent to the reservoir underground. At the bottom of the reservoir well, the hydrothermal fluid absorbs the heat from the earth, and steam is generated. In dry steam power plants, steam from the production well directly goes to the turbine. Direct steam is used to rotate the turbine which is connected to a generator. Then the water goes through a condenser. The condenser liquidizes the steam by decreasing the temperature. Then again the hydrothermal fluid is injected back to the reservoir through an injection well.

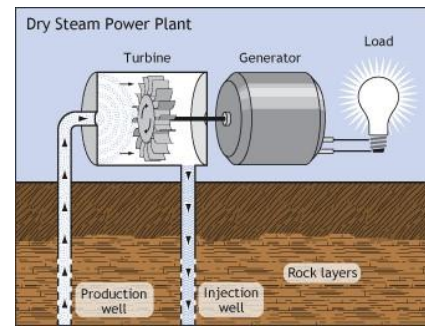

Fig. 1. Dry Steam Geothermal Power Plant [23]

The dry steam power plant emits a small amount of excess steam and some greenhouse gasses to the atmosphere [7]. These steam and gasses contribute directly to global warming [7]. The turbine blades become subjected to corrosion as steam directly hits them which consists of impurities and chemical elements [7].

2) *Flash Steam Power Plant*: In a flash steam power plant high-pressure hot water or hydrothermal fluid is taken out from the hydrothermal reservoir deep inside the earth and collected using a steam separator [8]. Figure 2 shows a schematic diagram of a flash steam power plant. Inside the separator, high-pressure hot water moves upwards on its own and its pressure keeps decreasing. This pressure decrease reduces the evaporation point of water and converts the hot water to steam. Then, the steam is separated by the steam separator. The separated steam is gone towards the turbine. The turbine is connected to a generator. The steam is used to drive the turbine and the turbine rotates the alternator and produces electrical energy. For flash steam power plants hydrothermal fluid of above 182°C is required [7]. This process does not hamper the turbine blade but does emit greenhouse gasses.

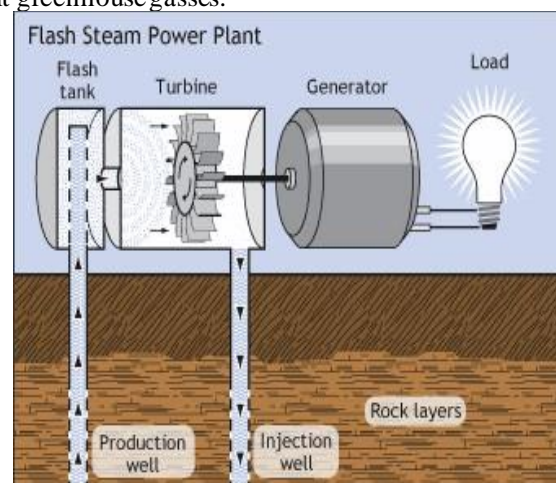

Fig. 2. Flash Steam Geothermal Power Plant [23]

3) *Binary Cycle Power Plant*: In a binary cycle power plant the heat energy of hot water from the hydrothermal reservoir is transferred to a secondary liquid. Figure 3 shows a schematic diagram of a binary cycle power plant. The secondary liquid has a lower evaporation point than water.

So, only hot water is enough to boil the secondary liquid and turn it into steam. This steam is supplied to the turbine. The turbine is connected to a generator. The steam rotates the turbine and the turbine rotates the rotor inside the generator. A rotating rotor produces electrical energy. The major advantage of this technology is the low operating temperature [7]. The required temperature for the hydrothermal liquid is low because the secondary liquid has a lower boiling point than water. Binary system geothermal power plants are closed-loop systems, thus, no greenhouse gases get emitted into the atmosphere. But, the pipes that are used to collect water from the underground gets filled with salt layers as that water contains minerals and salts. So, those pipes are required to change periodically.

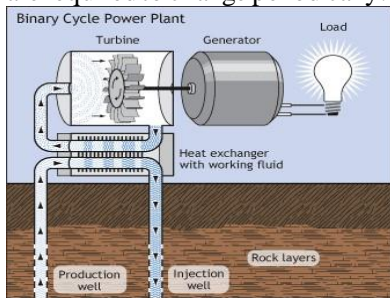

Fig. 3. Binary Cycle Geothermal Power Plant [23]

C. Problems With Current Geothermal Processes:

- Dependence on geography is the first disadvantage of current geothermal power plants [8]. The ground has to be stable for the implementation of the water reservoir as a small shift of reservoir placement can cause drawbacks to generation.
- One major problem in geography selection is, injection of water creates a risk of sudden earthquakes [24]. We can never be sure that we will find hot water underground. The drilling cost becomes a waste if we can't find any water reservoir or inject water for risks of an earthquake.
- Certain geographic conditions such as high underground temperature, natural hydrothermal fluid reservoirs, and access to that fluid should be present to make the geothermal power generation possible [8].
- The surface instability [9] related to geothermal power generation can be recognized as a disadvantage. According to [10], drilling water injection wells in geothermal power plants can cause surface instability.
- Geothermal power plants can have some minor greenhouse gas emissions which contribute to global warming, acid rain, radiation, and noxious smell [7].
- Although a binary cycle power plant can prevent greenhouse gas or minerals to affect the environment, it does have its disadvantage. The pipes used for the closed-loop hydrothermal water system get filled up with layers of salt and

minerals that come up from the underground with the water.

These disadvantages of current geothermal power plant technologies can be avoided by the implementation of graphene in the heat extraction process. As graphene is a superconductor of heat and is the strongest material ever invented. The geographical problems can be bypassed. As no hydrothermal fluid is required the availability of it is unnecessary. Only the heat comes up from below eliminating the greenhouse gas emission problem. The wire does not let any minerals or salt to come up from underground. So, every problem we have been having concerning geothermal power generation can be avoided.

III. EXTRACTION OF GEOTHERMAL HEAT BY GRAPHENE

A. Introduction of Graphene

Graphene / græfɪn / [11] is an allotrope of carbon consisting of a single layer of atoms arranged in a two-dimensional honeycomb lattice [12]. Figure 4 shows an atomic scale of graphene later. The name is a portmanteau of "graphite" and the suffix -ene, reflecting the fact that the graphite allotrope of carbon consists of stacked graphene layers [13]. Each atom in a graphene sheet is connected to its three nearest neighbors by a  $\sigma$ -bond and contributes one electron to a conduction band that extends over the whole sheet. This is the same type of bonding seen in carbon nanotubes and polycyclic aromatic hydrocarbons, and (partially) in fullerenes and glassy carbon [14].

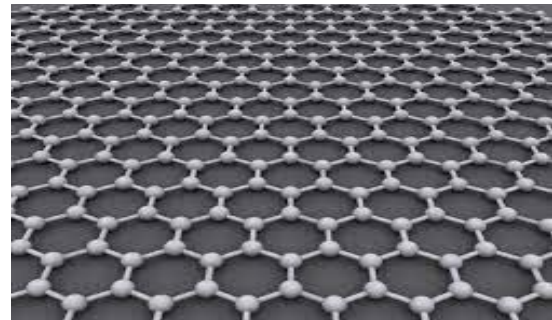

Fig. 4. Graphene is an Atomic Scale [15]

The conduction bands make graphene a semimetal with unusual electronic properties that are best described by theories for massless relativistic particles [12]. Graphene conducts heat and electricity very efficiently along its plane. The material strongly absorbs light of all visible wavelengths [16], which accounts for the black color of graphite; yet a single graphene sheet is nearly transparent because of its extreme thinness. The material is also about 100 times stronger than would be the strongest steel of the same thickness [17].

B. Properties of Graphene

- Thermal conductivity – 5300 W/m-K [18]
- Density – 2267 kg/m<sup>3</sup> [19]
- Heat Capacity at constant pressure – 2100 J/kg-K [18]
- Melting point – 3652°C [5]

- Tensile strength – 130 gigapascals [6]

From the properties of graphene, it is clear that it is a superconductor of heat. It also has a high melting point with a tensile strength much higher than steel.

For these properties of graphene, we can use it as a substitute for hydrothermal fluid as a medium for heat extraction. Strings of graphene can be attached to make a wire. That wire will be placed underground to extract geothermal heat through it. As graphene has a sufficient melting point, it will not melt while extracting heat. It will also not change its shape due to its high tensile strength.

C. Proposed Method of Heat Extraction by Graphene

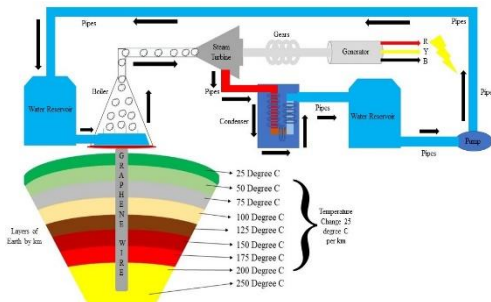

Fig. 5. Graphene-Based Geothermal Power Plant

The temperature of the earth increases as we dig under the top at an average of 25°C per km [20]. So, the deeper we dig the more heat we get. We have been able to dig as far as 12,262 m or more than 12 kilometers called Kola Superdeep Borehole in Russia [21]. The temperature required in a boiler for continuous generation is near to 200°C. So, if we dig a hole approximately 7-8 kilometers, we will have our required temperature. Figure 5 shows the proposed method of heat extraction using graphene wire.

After we dig the hole, we shall put our constructed thick graphene wire inside the hole. As graphene is a superconductor of heat, it will start to bring up only the heat from the underground. That heat will be used to boil water inside a boiler. The boiled water or steam will be passed through pipes and a nozzle to acquire super speed. The kinetic energy of the steam will stroke the steam turbine blades and produce rotational energy on the turbine. The turbine will be coupled with an alternator with required gears for rotation control. Depending on the pole of the generator and the required frequency, rotation of the alternator will be controlled by the gears. The rotating alternator will produce 3-phase electrical energy, which will be supplied to the transformer for distribution or to the national grid.

IV. SIMULATION OF HEAT TRANSFER THROUGH GRAPHENE

For the simulation of heat transfer through a graphene wire, the COMSOL Multiphysics Platform of version 5.3a was used. COMSOL is a famous software for the simulation of heat through materials. As the 5.3a version of the software does not have Graphene as a built-in material, we have created a blank material and defined the thermal properties of it as the same as graphene. The steps of the simulation and the results are stated in the following sub-sections.

A. Simulation Steps

1) Adding Study and Physics Interface: A time-dependent study on heat transfer in a solid interface was used. Figure 6 shows the process.

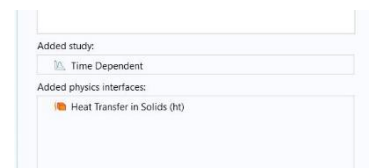

Fig. 6. Study and Physics Interface on COMSOL

2) Designing the Model and Defining the Properties of the material: As graphene wire will be used for heat extraction, the shape of the material will be cylindrical. In COMSOL 5.3a graphene is not a built-in material, so, the properties of graphene were defined taking a blank material from the material section. Figure 7 and 8 shows the processes.

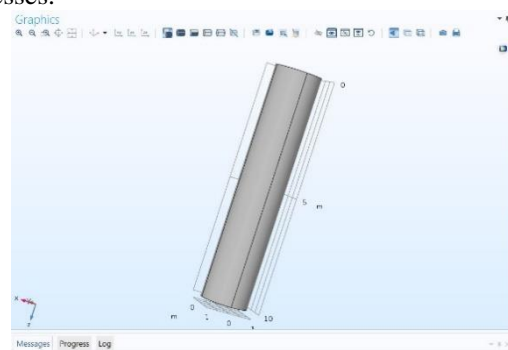

Fig. 7. Cylindrical Model of Graphene

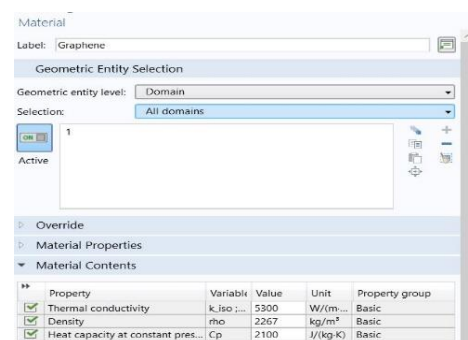

Fig. 8. Defining the Properties of Graphene

3) Providing the temperatures of two Sides and Building a Mesh: The bottom of the wire has 200°C and the top of the wire has 25°C. These temperatures were given on the model. After defining the temperatures the project was built by building the mesh. Figure 9,10 and 11 shows the processes.

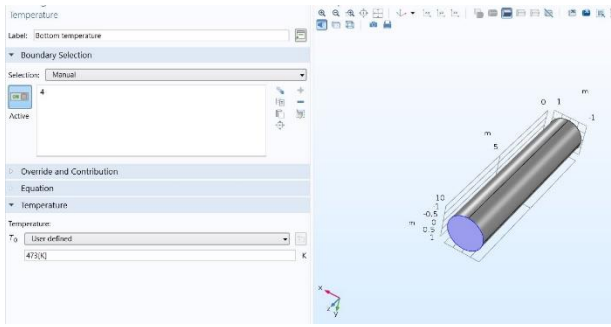

Fig. 9. Providing Hotter Side Temperature

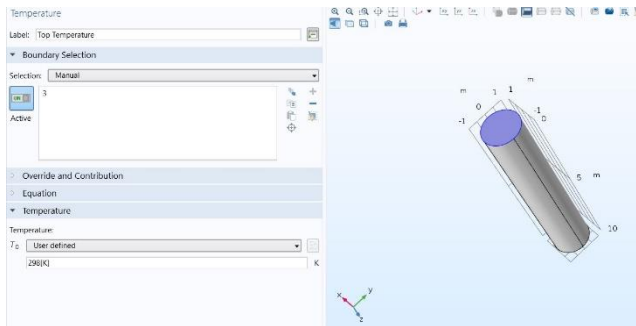

Fig. 10. Providing Cooler Side Temperature

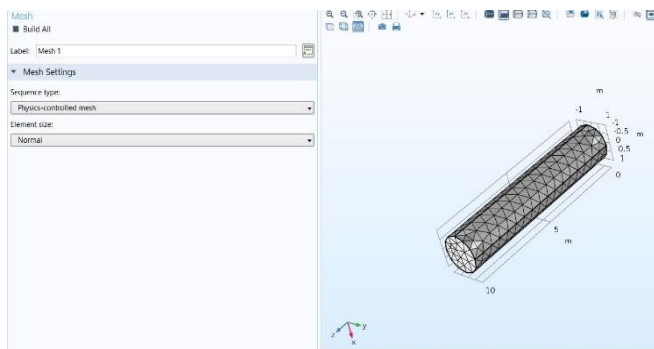

Fig. 11. Building the Mesh for Study

4) *Setting the Time Range:* The time range was selected for the simulation. It is the time that was given for the heat to transfer before we observe results. The time range was given 0,0.1,10 hours. After this, the program was computed and results were taken. Figure 12 shows the process.

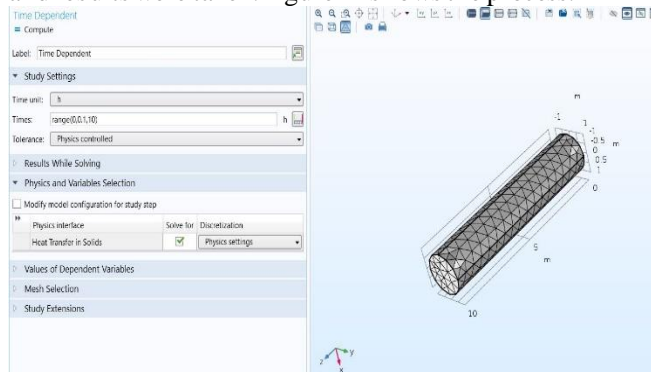

Fig. 12. Setting the Time Range

## B. Results

1) *Heat transfer and Isothermal Contours:* After computation, the heat transfer and the isothermal contours were physically visible. It shows that after an amount of time heat transfers through the material. The point where the heat started to flow had a temperature of 200°C and the place where it reached had a temperature of 25°C. The simulation clearly shows that thermal energy gets transferred through the material. Figure 13, 14, 15, and 16 shows the processes.

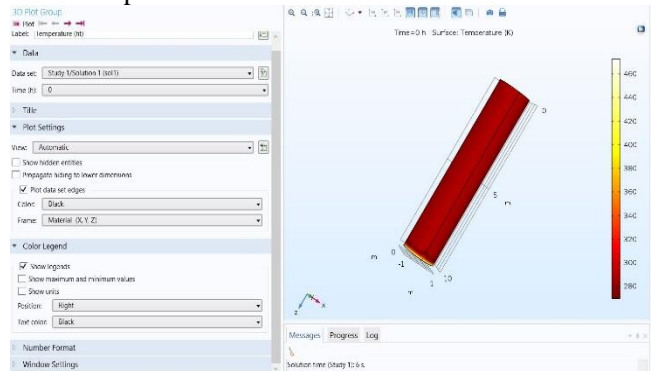

Fig. 13. Temperature at t = 0 hours

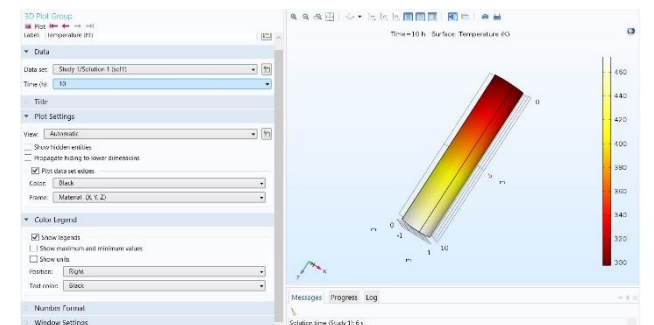

Fig. 14. The temperature at t = 10 hours

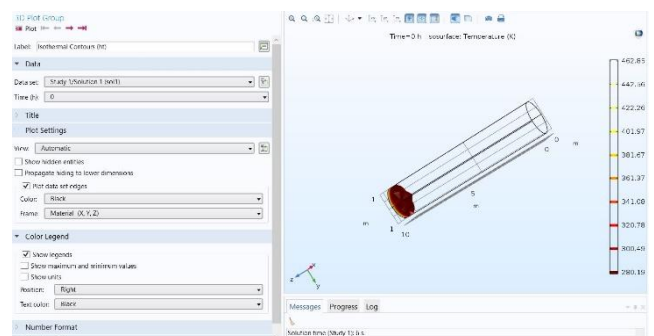

Fig. 15. Isothermal Contours at t = 0 hours

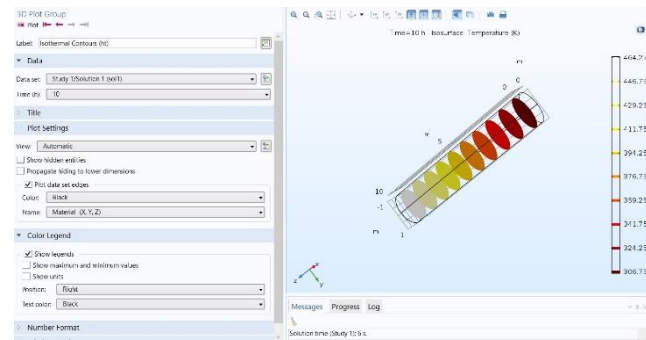

Fig. 16. Isothermal Contours at t = 10 hours

2) *Graphical Result:* We selected a 1D plot group and a one-line graph to plot the temperature change of the material as time passed. We selected a boundary along the height of the material to plot the temperature increase. Figure 17 shows the process and figure 18 shows the graph.

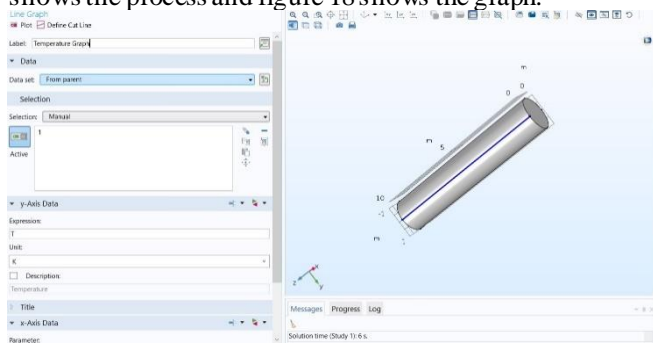

Fig. 17. Selecting the boundary line for temperature rise plot

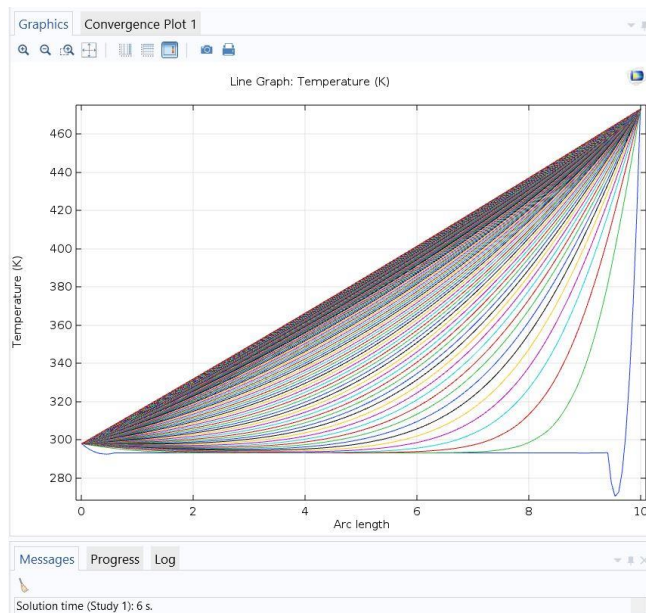

Fig. 18. Temperature rising graph of the material (graphene)

The graph clearly shows that the temperature rises as time goes by in the boundary line along with the height of the material. So, it can be said that, if we put the wire underground where the temperature is high it will bring up the heat to the top where the temperature is low. By this, we

can only bring up the geothermal heat without using any water. This will ensure that no pollutants can come out of the hole, no greenhouse gas gets emitted and no requirement of maintenance due to the mineral and salt layer along the hydrothermal fluid pipe. It completely removes the requirement of using a hydrothermal fluid to bring up the heat.

### V. GLOBAL GEOTHERMAL STATE

The largest group of geothermal power plants in the world is located at The Geysers, a geothermal field in California, United States. As of 2004, five countries (El Salvador, Kenya, the Philippines, Iceland, and Costa Rica) generate more than 15% of their electricity from geothermal sources [22].

Geothermal electricity is generated in the 24 countries listed in the table below. During 2005, contracts were placed for an additional 500 MW of electrical capacity in the United States, while there were also stations under construction in 11 other countries. Enhanced geothermal systems that are several kilometers in depth are operational in France and Germany and are being developed or evaluated in at least four other countries [22].

TABLE I. INSTALLED GEOTHERMAL ELECTRIC CAPACITY [22]

Country	Capacity (MW) 2015	Capacity (MW) 2018	Capacity (MW) 2019	Share of National Generation (%)
USA	3450	3591	3676	0.3
Indonesia	1340	1948	2133	3.7
Philippines	1870	1868	1918	27.0
Turkey	397	1200	1526	0.3
New Zealand	1005	1005	1005	14.5
Mexico	1017	951	962.7	3.0
Italy	916	944	944	1.5
Kenya	594	676	861	51.0
Iceland	665	755	755	30.0
Japan	519	542	601	0.1

### VI. CONCLUSION

Geothermal energy is one of the most promising renewable resources in the world. If we can harvest the cleanest of energies the damages that we have done to our planet will reduce day by day. It is high time mankind started to unlock geothermal energy's full potential. Although geothermal energy has an enormous future in clean energy

generation, the drawbacks are pushing its studies back. By replacing the past ways of heat extraction with the proposed one, we can ensure a clean and optimistic process of geothermal power generation.

#### REFERENCES

- [1] Nan Wu and Xianfeng, "Geothermal Energy Current State and Utilization in Oilfield, China: An Overview", Liu School of Geosciences Yangtze University Jing Zhou, China.
- [2] M. Kheshiti and X. Kang, "Geothermal energy, a key point in energy and development in China," International Conference on Renewable Power Generation (RPG 2015), Beijing, 2015, pp. 1-4.
- [3] H. Kulasekara and V. Seynulahdeen, "A Review of Geothermal Energy for Future Power Generation," 2019 5th International Conference on Advances in Electrical Engineering (ICAEE), Dhaka, Bangladesh, 2019, pp. 223-228, doi: 10.1109/ICAEE48663.2019.8975470.
- [4] An article on, "Environmental Impacts of Geothermal Energy", published on May 5, 2013.
- [5] Graphene Properties, accessed on 1 Nov, 2020. Available at, "https://www.americanelements.com/graphene-1034343-98-0"
- [6] Properties of Graphene, accessed on 1 Nov 2020. Available at, "https://www.graphenea.com/pages/graphene-properties#.X6LLEmgzZPY"
- [7] G.M. Nagala, M.B. Oumarou, and F.A. Oluwole, "Review of Geothermal Energy Technology and its Potential for Power Generation in Borno Basin, Nigeria," Annals of Borno, vol. 25, pp. 91-100, Dec. 2015.
- [8] J. Lofthouse, R.T. Simmons, and R.M. Yonk, Reliability of Renewable Energy: Geothermal. Utah: Institute of Political Economy Utah State University, 2015, Accessed on Apr. 20, 2019. [Online]. Available: <https://www.usu.edu/ipe/wpcontent/uploads/2015/11/Reliability-Geothermal-Full-Report.pdf>
- [9] C. R. DeNardin et al., "Underground geothermal energy to reduce the residential electricity consumption," 3rd Renewable Power Generation Conference (RPG 2014), Naples, 2014, pp. 1-6.
- [10] M. Shmeleva, "Geothermal Energy Production from Oil and Gas Wells," M.Sc. thesis, KTH School of Industrial Engineering and Management, Stockholm, 2018. Accessed on April 20, 2019. [Online]. Available at, <http://www.diva-portal.org/smash/get/diva2:1293872/FULLTEXT01.pdf>
- [11] "Graphene definition, meaning – what is graphene in the British English Dictionary & Thesaurus – Cambridge Dictionaries Online". [cambridge.org](http://cambridge.org).
- [12] Geim, A. K.; Novoselov, K. S. (26 February 2007). "The rise of graphene". *Nature Materials*. 6 (3): 183–191. arXiv:cond-mat/0702595. Bibcode:2007NatMa...6..183G. doi:10.1038/nmat1849. PMID 17330084. S2CID 14647602.
- [13] Boehm, H. P.; Clauss, A.; Fischer, G. O.; Hofmann, U. (1 July 1962). "Das Adsorptionsverhalten sehr dünner Kohlenstoff-Folien". *Zeitschrift für Anorganische und Allgemeine Chemie*. 316 (3–4): 119–127. doi:10.1002/zaac.19623160303. ISSN 1521-3749.
- [14] Aristides D. Zdetsis and E. N. Economou (2015): "A pedestrian approach to the aromaticity of graphene and nanographene: Significance of Huckel's (4n+2)  $\pi$  electron rule". *Journal of Physical Chemistry - Series C*, Volume 119, issue 29, pages 16991–17003. doi: 10.1021/acs.jpcc.5b04311.
- [15] Graphene is an Atomic Scale, accessed on 2 Nov, 2020. Available at, "https://en.wikipedia.org/wiki/Graphene#cite\_note-geim2007"
- [16] Nair, R. R.; Blake, P.; Grigorenko, A. N.; Novoselov, K. S.; Booth, T. J.; Stauber, T.; Peres, N. M. R.; Geim, A. K. (6 June 2008). "Fine Structure Constant Defines Visual Transparency of Graphene". *Science*. 320 (5881): 1308. arXiv:0803.3718.
- [17] Lee, Changgu (2008). "Measurement of the Elastic Properties and Intrinsic Strength of Monolayer Graphene". *Science*. 321 (385): 385–388. Bibcode:2008Sci...321..385L. doi:10.1126/science.1157996. PMID 18635798. S2CID 206512830.
- [18] Eric Pop, Vikas Varshney, and Ajit K. Roy, "Thermal properties of graphene: Fundamentals and applications."
- [19] The density of graphene. accessed on 3 Nov, 2020. Available at, "https://www.quantachrome.com/general\_pdf/graphene.pdf"
- [20] The temperature increase as we go underground, Available at, "https://news.stanford.edu/pr/00/000315rocks.html#:~:text=Geologist%20calculate%20that%2C%20for%20every,7%2C300%20pounds%20per%20square%20inch."
- [21] Kola Superdeep Borehole, accessed on 3 Nov, 2020. Available at, "https://en.wikipedia.org/wiki/Kola\_Superdeep\_Borehole"
- [22] Global Geothermal State, accessed on 4 Nov, 2020. Available at, "https://en.wikipedia.org/wiki/Geothermal\_power#Worldwide\_production"
- [23] Types of Geothermal Power Plants, accessed on 4 Nov, 2020. Available at, "https://ww2.energy.ca.gov/almanac/renewables\_data/geothermal/types.html"
- [24] Why don't we all use geothermal energy? accessed on 5 Nov, 2020. Available at, "https://www.youtube.com/watch?v=-Ss\_wHCS1Aw"

#### AUTHOR PROFILE

##### Md. Zubaer Mahmud Rony



Physics Teacher, Kids Campus School. Former Assistant Automation Engineer at ARC Surfactants (Unilever Plant). Completed BSc. in Electrical and Electronic Engineering from Mymensingh Engineering College. Specialized on Industrial Automation, completed major on Electrical Power.

##### Engr. S M Anowarul Haque



Head of the Department and Assistant Professor, Mymensingh Engineering College. Publications: 1. Artificial Neural Network Based short term Load Forecasting for Mymensingh area of Bangladesh. 2. Short Term (Seven Day Basis) Load Forecasting of a Grid System in Bangladesh using Artificial Neural Network. 3. Design and Analysis of a Stand Alone Microgrid system for Saint Martin Island.

##### Md. Mostakim Rahman



BSc. in EEE Student on Mymensingh Engineering College. Specialized on Power Generation Techniques. Completing major on Electronics.

##### Nurun Nahar



BSc. in EEE Student on Mymensingh Engineering College. Specialized on Power Generation Techniques. Completing major on Electrical Po.