



SIMULATION OF TRANSIENT EQUILIBRIUM DECAY USING ANALOGUE CIRCUIT

***Abdullahi, N. K¹, Ango U.S². and Batu M. A¹**

¹Applied Science Department, College of Science & Technology, Kaduna Polytechnic, P.M.B.2021, Kaduna,

²Sokoto Energy Research Centre, Usmanu Danfodio University, Sokoto

*Correspondence Author: E-mail: nasirasman@yahoo.com

ABSTRACT

An analogue circuit which could be used for simulating Transient Equilibrium decay was constructed. The Transient Equilibrium decay considered was. $^{234}\text{Th} \xrightarrow[24.1\text{d}]{\beta} ^{234}\text{Pa} \xrightarrow[1.18\text{mins}]{\beta} \text{decay}$

series. An integrating time constant of 22 millisecond was chosen so as to minimize integrating error and a maximum voltage level of 10V was chosen for the design in order to avoid saturation of the Operational Amplifiers used. The differential equation describing the decay series to be mechanized on the analogue circuit was converted to voltage equation through amplitude scaling. Scale factors, $K_1 = 2.2 \times 10^{-3} \text{Vs}^{-1}$, $K_2 = 0.1\text{V}$, $K_3 = 6.35 \times 10^{-1} \text{Vs}$, $K_4 = 2.951 \times 10^2 \text{V}$ were calculated from ranges of problem variables. To speed up the decay series i.e. to cause machine time to be smaller than the problem, time scaling was employed with a scale factor a , given by 7.32×10^{-9} . When the construction was tested, it simulates the equilibrium decay with a percentage error of $\pm 3\%$.

Key words: analogue, simulation, transient, operational amplifiers, amplitude scaling

INTRODUCTION

An analog computer can be used to solve various types of problems. It solves them in an "analogous" way. Most general purpose analog computers use an active electrical circuit as the analogous system because it has no moving parts, a high speed of operation, good accuracy and a high degree of versatility. Active electrical networks consisting of resistors, capacitors, and op amps connected together are capable of simulating any linear system since the forward voltage transfer characteristics of these networks are analogous to the basic linear mathematical operations encountered in the system's mathematical model. The normal procedure for simulating a system starts with determining the mathematical model describing the physical quantities of interest. An analog block diagram is made to relate the sequence of mathematical operations and to aid

in scaling the variables. From the analog block diagram the electrical components are connected together (patched). The computer is operated and the computer variables observed on a recorder or oscilloscope (Paz, 2001).

The present work is an attempt to design a simple electronic analogue circuit to simulate an artificial radioactive decay. The design will use 741 operational amplifiers connected externally to resistors, capacitors and potentiometers to solve a set of coupled differential equation describing a radioactive decay from nuclide A with decay constant λ_a to form a nuclide B which in turn decays with decay constant λ_b to form a stable nuclide C. Such decay is represented as:



The growth and decay of the number of atoms of the differential nuclides present is represented by the action of coupled equation (Vujic, 2006)

$$\frac{dN_a}{dt} = -\lambda_a N_a$$

$$\frac{dN_b}{dt} = \lambda_a N_a - \lambda_b N_b$$

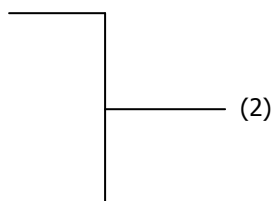

The mathematical model of an analog computer programmed to simulate a specific physical system is identical to the mathematical model of the system. Differential and /or algebraic equations in order to be

mechanized on the analog computer must first be converted to voltage equations, a scale factor or volts per physical unit ratio must be chosen for all the dependent variables (Ralston and Meek, 1976).

The voltage transfer characteristics of the electrical networks are analogous to the desired mathematical operations. The input and output voltages (computer variables) are analogous to the corresponding mathematical variables (problem variables) of the problem. Because of limitations of the computer or its associated input/output equipment, it is usually necessary to change the scale of the computer variables, thus forcing the values of a computer variable to differ from the corresponding problem variable values. It is important to understand that an analog computer solution is simply a voltage wave form whose time dependency is the same as that of the desired variable (Paz , 2001). The problem will be

scaled in amplitudes as well as in time. Amplitude scaling is done to avoid any arbitrary choice of the scale factors because this may lead to the solution being outside the voltage range of operation or alternatively being so small as to be lost among the inherent noise. Time scaling ensures that the problem can be solved in a shorter or longer time as the case may be (Dawe, 1980). The accuracy and stability of the analogue circuit is essentially set by the characteristics of the external components connected to the operational amplifier such as resistors, capacitors and potentiometers. The tolerances of the external components used in close loop set a limit on closed loop accuracy (Jacobowitz and Basford, 1974).

Methodology

The following radioactive decay illustrating artificial transient equilibrium decay was considered:

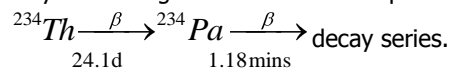

The design seeks to obtain $N_a(t)$ and $N_b(t)$ in the form of equivalent voltage levels which could be measured on the proposed analogue circuit. For practical reasons, integration operation is easier to implement than the differentiation operation. The reason lies in the fact that computer signals are real voltages and, therefore, are corrupted by noise to some extent. Since integration has a tendency to average out the effects of noise (while differentiation will accentuate it), a more precise solution can be obtained using

integration techniques (Paz, 2001). In order to limit the integrating error which increases with time, an integrating time constant of 22 millisecond was carefully chosen for each integrator, such that the feed back capacitors and input resistors take values of 2.2 μF and 1 $\text{k}\Omega$ respectively. To avoid saturation of the 741 operational amplifiers used a maximum voltage level of 10 volts was chosen for this design.

Amplitude scale factors are defined as follows:

Scale factor = $\frac{1 \text{ machine unit (M.U)}}{\text{maximum value of variable}}$ (Oroge, 1998): Thus, for the present problem,

$$K_1 = \frac{|V|_{\max}}{\left| \frac{dN_a}{dt} \right|_{\max}} \text{ ----- (3),}$$

$$K_2 = \frac{|V|_{\max}}{|N_A|_{\max}} \text{ ----- (4)}$$

$$K_3 = \frac{|V|_{\max}}{\left| \frac{dN_b}{dt} \right|_{\max}} \text{ ----- (5),}$$

$$K_4 = \frac{|V|_{\max}}{|N_b|_{\max}} \text{ ----- (6)}$$

Generally, time scaling for the derivative of x is given by [3]:

$$\frac{d^n x}{dt^n} = a^n \frac{dx^n}{dT^n} \text{ ----- (7)}$$

Where t = time at which a phenomenon actually occurs and T = time required for the phenomenon to occur on the computer, a is the scaling factor.

Combining amplitude and time scaling, the computer patched programme from equation 2 is obtained as:

$$\left(K_1 \frac{dN_a}{dT} \right) = \left[\frac{\lambda_a K_1}{a K_2} \right] \left(K_2 N_a \right) \text{ ----- (8)}$$

$$\left(K_3 \frac{dN_b}{dT} \right) = \left[\frac{\lambda_a K_3}{a K_2} \right] \left(K_2 N_a \right) - \left[\frac{\lambda_b K_3}{a K_4} \right] \left(K_4 N_b \right) \text{ ----- (8)}$$

Terms in brackets are computer terms and those in square brackets are potentiometer coefficients and

amplifier gains. The corresponding patch programme is shown in Figure 1.

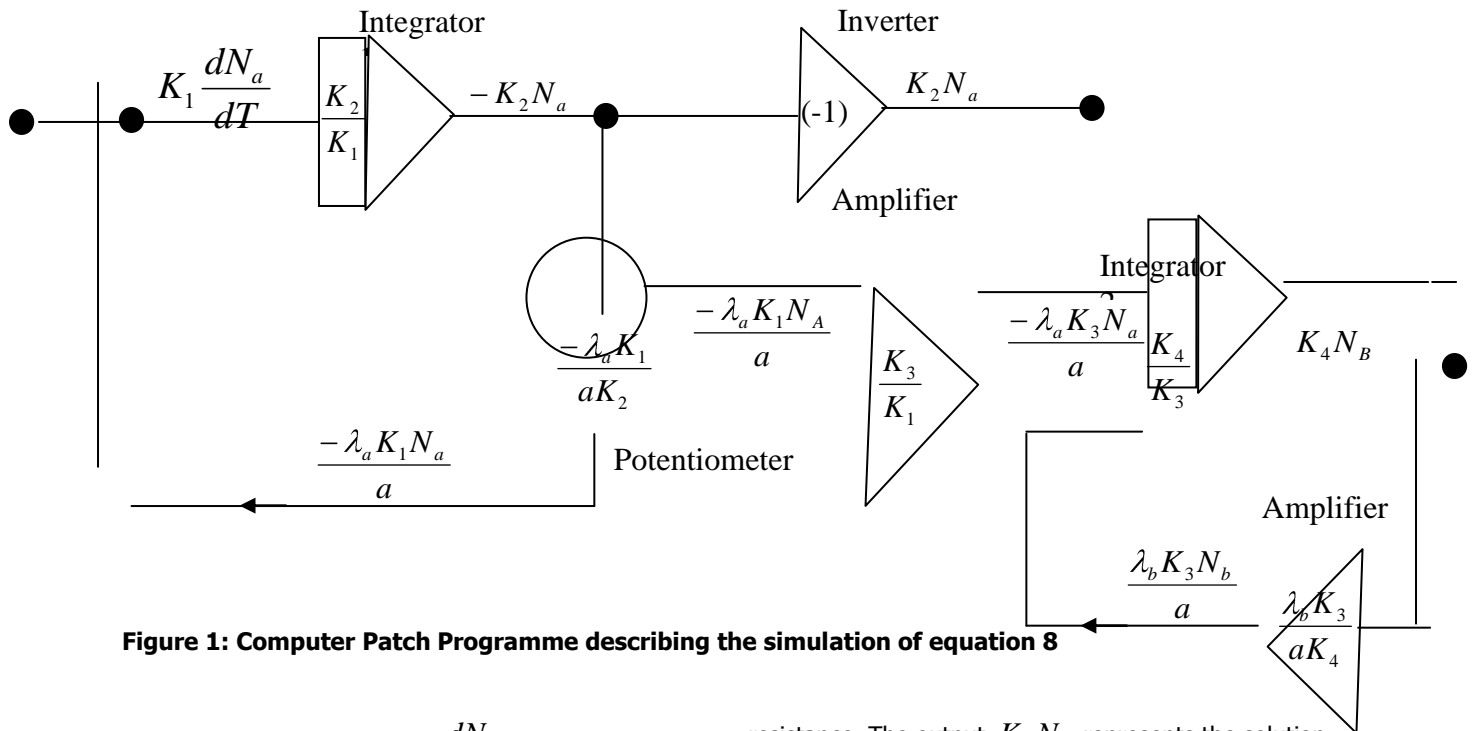

Figure 1: Computer Patch Programme describing the simulation of equation 8

From fig 1, the function $K_1 \frac{dN_a}{dT}$ is applied at the input of the first integrator and inverted in sign so that its output voltage is $-K_2 N_a$, $\frac{K_2}{K_1}$ is the gain of the integrator marked 1. The voltage $-K_2 N_a$ is finally inverted in sign to $K_2 N_a$ through an inverter, whose input resistance equals its feed back

The function $\left(-K_3 \frac{dN_b}{dT}\right)$ is integrated and is inverted in sign by the second integrator so that its output voltage is $+K_4 N_B$. The output $K_4 N_B$ represents the solution of the second decay. $\frac{-\lambda_a K_1}{a K_2}$ is a potentiometer coefficient, while $\frac{K_3}{K_1}$ and $\frac{\lambda_b K_3}{a K_4}$ are the gains of the first and second amplifier respectively.

resistance. The output $K_2 N_a$ represents the solution of the differential equation i.e. first decay. The function $-\lambda_a N_a$ and $\lambda_b N_b$ are applied to the input network of a summing integrator. The input resistors and the integrator capacitors are chosen so that N_b is multiplied by the constant scale factor λ_b and by their sum i.e. $-\lambda_a N_a$ and $\lambda_b N_b$ therefore, the defining relation is given by

$$\left(-K_3 \frac{dN_b}{dT}\right) = \left[-\lambda_a K_3 / a K_2\right] \left(K_2 N_a\right) + \left[\lambda_b K_3 / a K_4\right] \left(K_4 N_b\right)$$

The function $\left(-K_3 \frac{dN_b}{dT}\right)$ is integrated and is inverted in sign by the second integrator so that its output

voltage is $+K_4 N_B$. The output $K_4 N_B$ represents the solution of the second decay. $\frac{-\lambda_a K_1}{a K_2}$ is a

potentiometer coefficient, while $\frac{K_3}{K_1}$ and $\frac{\lambda_b K_3}{a K_4}$ are the gains of the first and second amplifier respectively.

Design consideration

Using an initial number of nuclides $|N_0|_{\max} = 100$, the scale variables and other parameters for the computer patched programme were obtained as follows:

$$N_a = 99.97$$

$$\lambda_a = 3.328 \times 10^{-7} \text{ s}^{-1}$$

$$t_{\max} = 1051.2 \text{ s}$$

$$N_b = 3.399 \times 10^{-3}$$

$$\lambda_b = 9.788 \times 10^{-3} \text{ s}^{-1}$$

$$t_{\text{real time}} \approx 3.0046753 \times 10^6 \text{ s}$$

$$T \text{ (computer time)} \approx 22 \times 10^{-3} \text{ s}$$

$$\left| \frac{dN_a}{dT} \right|_{\max} = 4547$$

$$K_1 = \frac{|V|_{\max}}{\left| \frac{dN_a}{dT} \right|_{\max}} = 2.2 \times 10^{-3} \text{ Vs}^{-1},$$

$$K_3 = \frac{|V|_{\max}}{\left| \frac{dN_b}{dT} \right|_{\max}} = 6.35 \times 10^{-1} \text{ Vs}^{-1},$$

$$\alpha = \frac{T}{t} = 7.32 \times 10^{-9}$$

$$\left| \frac{dN_b}{dT} \right|_{\max} = 15.75$$

$$K_2 = \frac{|V|_{\max}}{|N_a|_{\max}} = 0.1 \text{ V}$$

$$K_4 = \frac{|V|_{\max}}{|N_b|_{\max}} = 2.951 \times 10^3 \text{ V}$$

RESULT AND DISCUSSION

Using an integrating time constant of 22 millisecond, the value of the time scaling factor, α , was obtained as 7.32×10^{-9} . This value obtained which is less than unity means that the phenomena will occur faster in the computer than it does in nature (Dawe 1980). The potentiometer coefficient obtained were approximately 0.1 with a gain of 10 for each integrator. This value will ensure that the scale factors would be limited within the voltage range and the solution would not be outside the voltage range of

operation. Scaled quantities in the form of $\left(\frac{K_4 N_b}{K_3 N_a} \right)$ were compared with corresponding decay constant

ratio $\frac{\lambda_b}{\lambda_b - \lambda_a}$ and a good agreement was obtained within a percentage error of $\pm 2.1\%$ on the average for the transient equilibrium decay (table 1). This agrees with the transient equilibrium approximation

i.e. $\frac{N_b}{N_a} \approx \frac{\lambda_b}{\lambda_b - \lambda_a}$ since $\lambda_a < \lambda_b$ (Vujic, 2006).

This design test was primarily done to see if the circuit would simulate the Transient decay with a fairly reasonable accuracy if it is eventually constructed.

Table 1: Testing artificial Transient Equilibrium Decay.

$K_2 N_a$	$K_4 N_b$	$\frac{K_4 N_b}{K_2 N_a}$	$\frac{\lambda_b}{\lambda_b - \lambda_a}$
5.0	5.018	1.0036	1.000034002
2.5	2.509	1.0036	-
1.25	1.237	0.0098	-
0.625	0.627	1.0032	-
0.312	0.313	1.0031	-

When the circuit was constructed and the voltage was measured on the oscilloscope, the values of the output obtained were 10.3 V for the parent nuclide and 9.7 V for the daughter nuclide. This gives a good

agreement to within percentage error of $\pm 3\%$. Fig 2 shows the circuit diagram for testing the analogue circuit.

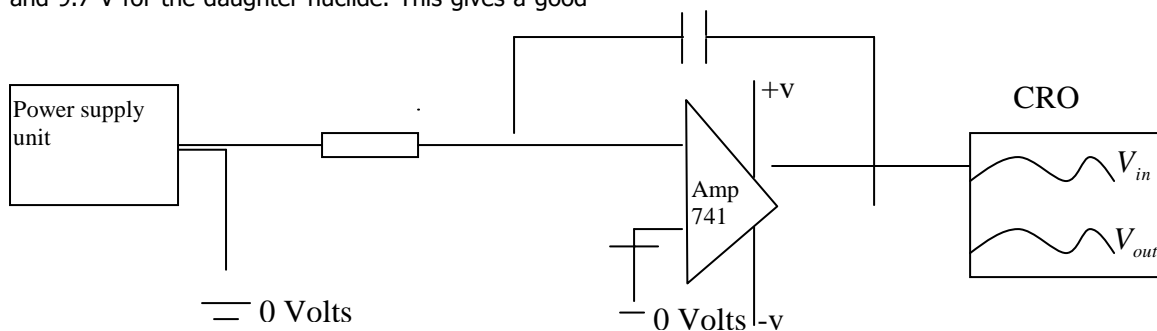

Figure 2: Circuit Diagram for testing the analogue computer

CONCLUSION

Although the design seeks to obtain a signal output of 10 V which is analogous to the physical system being simulated, the values of 10.3 V and 9.7 V obtained for the parent and daughter nuclides respectively, means that the constructed circuit simulated the differential

equation describing the Transient equilibrium decay with a fairly reasonable accuracy. Hence, understanding the equilibrium for a given decay series through simulation will help scientists to estimate the amount of radiation that will be present at various stages of the decay.

REFERENCES

Dawe, D.F. (1980). Analogue computing techniques. *Wireless World*, July. pp 55- 59

Jacobowitz, S and Basford, A. (1974). *Electronic computers made simple*. Howard and Wyndham Ltd

Oroge, C.O. (1998). *Control system engineering*. University Press Plc. Pp 209-235

Paz, R. (2001). *Analog computing technique*, chapter 1. Available at <http://www.ece.nmsu.edu/anaman>. Pp 1-55. Retrieved 4th February, 2007

Ralston, A and Meek, L.C. (1976). *Encyclopedia of Computer Science*. Litton Publishing Company. Pp 59-86

Vujic, J. (2006). *Radioactive decay*, Lecture 3. Available at [http://www.nucmedconsultant.com/tutorials/lecture notes](http://www.nucmedconsultant.com/tutorials/lecture_notes). Pp 1-43 .Retrieved 4th February, 2007