

HOSTED BY



ELSEVIER

Contents lists available at [ScienceDirect](http://www.sciencedirect.com)

The Egyptian Journal of Medical Human Genetics

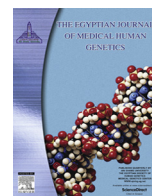
journal homepage: www.sciencedirect.com

Original article

Germline variants in the *ATM* gene and breast cancer susceptibility in Moroccan women: A meta-analysisChaymaa Marouf^{a,b,*}, Omar Hajji^c, Amal Tazzite^{a,b}, Hassan Joughadi^d, Abdellatif Benider^d, Sellama Nadifi^{a,b}^a Laboratory of Genetics and Molecular Pathology–Medical School of Casablanca, Casablanca, Morocco^b University Hassan II Ain Chock, Center Of Doctoral Sciences "In Health Sciences", Casablanca, Morocco^c Department of Oncology, Littoral Clinic, Casablanca, Morocco^d Mohammed VI Center for Cancer Treatment, Ibn Rochd University Hospital, Casablanca, Morocco

ARTICLE INFO

Article history:

Received 12 October 2016

Accepted 23 February 2017

Available online 6 March 2017

Keywords:

Breast cancers

ATM gene

Germline mutation

Genetic susceptibility

Moroccan population

ABSTRACT

Background: The *ATM* gene encoding a large protein kinase is mutated in ataxia-telangiectasia (AT), an autosomal recessive disease characterized by neurological and immunological symptoms, and cancer predisposition. Previous studies suggest that heterozygous carriers of *ATM* mutations have an increased risk of breast cancer compared with non carriers, but the contribution of specific variants has been difficult to estimate. However, two functional *ATM* variants, c.7271T > G and c.1066-6T > G (IVS10-6T > G), are associated with increased risk for the development of breast cancer.

Methods: To investigate the role of *ATM* in breast cancer susceptibility, we genotyped 163 case patients with breast cancer and 150 healthy control individuals for the c.7271T > G and c.1066-6T > G (IVS10-6T > G) *ATM* variants using polymerase chain reaction (PCR)-restriction fragment length polymorphism (RFLP) analysis.

Results: We did not detect the *ATM* c.7271T > G and c.1066-6T > G (IVS10-6T > G) mutations in any of 150 healthy control individuals and 163 breast cancer patients, including 59 women diagnosed with breast cancer at an early age (<40 years), 10 women with bilateral breast cancer, and 6 women with ovarian cancer.

Conclusion: These observations suggested that the more common c.1066-6T > G (IVS10-6T > G) mutation and the rare c.7271T > G variant are not a risk factor for developing breast cancer in the Moroccan population. Larger and/or combined association studies are needed to clarify this issue.

© 2017 Ain Shams University. Production and hosting by Elsevier B.V. This is an open access article under the CC BY-NC-ND license (<http://creativecommons.org/licenses/by-nc-nd/4.0/>).

1. Introduction

Biallelic germline mutations in the *ATM* gene (MIM# 208900) are linked to the rare human autosomal recessive disorder called ataxia-telangiectasia (AT). The syndrome has an estimated frequency of 1 in 40,000 to 1 in 100,000 live births and is characterized by various clinical features such as cerebellar neurodegeneration (ataxia), dilated blood vessels in the eyes and skin (telangiectasia), immunodeficiency, growth retardation, premature aging, chromosomal instability, increased sensitivity to ionizing radiation and a highly increased susceptibility to cancer, in particular leukaemia

and lymphomas [1–13]. *ATM*, a member of the phosphatidylinositol 3-kinase-like family, codes for a large serine-threonine kinase of 3056 amino acids that plays a central role in sensing and signaling the presence of DNA double-strand breaks that may be caused by exposure to ionizing radiation or other types of DNA damaging agents [14–16].

The *ATM* gene, located on human chromosome 11q22.3-23.1, extends over 150 kb of genomic DNA composed of 66 exons, giving rise to a transcript of approximately 13 kb that contains an open reading frame (ORF). It has been reported to be involved in numerous damage repair signaling pathways and cell-cycle checkpoints [6,17–20]. Loss of heterozygosity in the region of the *ATM* gene has been detected in approximately 40% of human sporadic breast tumors [21–25]. Breast cancer patients with the combination of radiation treatment and an *ATM* missense variant resulted in a shorter mean interval to develop a second tumor than patients

Peer review under responsibility of Ain Shams University.

* Corresponding author at: University Hassan II Ain Chock, Center Of Doctoral Sciences "In Health Sciences", Casablanca, Morocco.

E-mail address: maroufchaymaa@gmail.com (C. Marouf).<http://dx.doi.org/10.1016/j.ejmhg.2017.02.002>

1110-8630/© 2017 Ain Shams University. Production and hosting by Elsevier B.V.

This is an open access article under the CC BY-NC-ND license (<http://creativecommons.org/licenses/by-nc-nd/4.0/>).

without radiation treatment and *ATM* germline variant [26]. Previously, several epidemiological case-control studies based on relatives of AT and breast cancer have estimated that the heterozygous carriers of *ATM* mutations are at increased risk of breast cancer and have a two to thirteen fold risk [4,27–39], with some evidence of higher relative risk under the age of 50 years. In spite of that, studies of patients with breast cancer have so far failed to consistently demonstrate an elevated prevalence of germline *ATM* gene mutations among breast cancer cases relative to controls [32,33].

Since the cloning of the *ATM* gene in 1995 [40], many case-control studies have carried out mutation screening and single nucleotide polymorphism (SNP) genotyping to clarify the role of *ATM* genetic variation in breast cancer predisposition [41–47]. Specific functional variants of the *ATM* gene have been individually associated with higher breast cancer risk. One particular *ATM* missense mutation, c.7271T > G, was originally identified in two British A-T families with atypical clinical presentation and an excess of breast cancer. That variant was associated with a 12.7-fold (95% confidence interval [CI] 53.5–45.9; P50.003) increase in breast cancer risk [48]. The results have not been replicated in subsequent studies [29,49,50]. However, Tavtigian and colleagues did show that missense substitutions in the FAT and Kinase domains, including c.7271T > G, confer greater risk than do truncating variants. The role of missense substitutions uncovered in this paper also somewhat increases the best estimate for the population carrier frequencies of variants in *ATM* that are pathogenic for breast cancer [51].

A second, more common, the out-of-frame splicing mutation c.1066-6T > G (IVS10-6T > G), has also been associated with an increased risk of breast cancer in some [38,52] but not all [49] studies. This pathogenic mutation leads to incorrect splicing of exon 11 and exon skipping, resulting in a frame-shift starting at codon 355 and subsequently truncation of the protein at codon 371. The loss of exon 11 in the mRNA was the pathogenic consequence of this splicing mutation which produced less than 10% of full-length *ATM* mRNA and *ATM* protein [44]. The frequent occurrence of the IVS10-6T > G and c.7271T > G in breast cancer patients prompted the question whether this mutation frequently arises de novo in the population. A complete understanding of this breast cancer-related *ATM* variant and its impact on human health requires, besides a genetic and functional analysis, an insight into its natural history. Thus, the purpose of the current study was to investigate the associations between the c.7271T > G and c.1066-6T > G *ATM* gene variants and breast cancer risk in case-control series from Moroccan population.

2. Subjects and methods

2.1. Study population

Cases were 163 female patients affected with breast cancer as the first diagnosed cancer. Among them, 113 were recruited from Mohammed VI Center for Cancer Treatment of Ibn Rochd University Hospital of Casablanca during 2009–2010 and 50 patients were recruited from the Department of Oncology of the Littoral Clinic of Casablanca during 2013.

Clinico-pathological parameters including age at diagnosis, menopausal status, histology type, tumor size, Scarff-Bloom-Richardson (SBR) grade, lymph nodes status, and hormone receptors status were obtained from patients' medical records. The group of sporadic cases (n = 75) presented a median age at diagnosis of 36.9 years (range 23–59 years). The group of familial breast and/or ovarian cases (n = 59) presented a median age at diagnosis of 44.8 years (range of 25–67 years), and included women with specific family-history criteria (Fig. 1):

- Three or more first or second degree relatives with breast cancer diagnosed in the same familial branch, at any age
- Two first degree relatives with breast cancer, with at least one early onset breast cancer case (≤ 40 years).

The controls were 150 female blood donors collected through the Service of Genetics and Molecular Pathology Laboratory. All blood donors were healthy and with no personal history of breast cancer. Median age at blood donation was 36.4 years (range of 20–77 years). All the individuals included in the present case-control study signed an informed consent to the use of their biological material for genetic research purposes approved by the Ethic Committee for Biomedical Research in Casablanca (CERBC) of the Faculty of Medicine and Pharmacy in accordance with The Code of Ethics of the World Medical Association (declaration of Helsinki) for experiments in humans.

2.2. DNA isolation and PCR-RFLP amplification

Genomic DNA was extracted from peripheral blood leukocytes using the salting out procedure [53]. Genomic DNA was dissolved in TE (10 mM Tris-HCl and 0.1 mM EDTA, pH 8.0), confirmed by agarose gel electrophoresis. Spectrophotometry was used to quantify DNA using the Nanovue TM Plus spectrophotometer.

Polymerase chain reaction-restriction fragment length polymorphism (PCR-RFLP) analysis was performed to determine the T7271G and IVS10-6T > G variants of *ATM* gene.

2.3. *ATM* T7271G variant analysis

The *ATM* c.7271T > G mutation was detected by amplifying genomic DNA with the forward primer 5'-TGAAAAGAGCCAAAAG GAGG-3' and the reverse primer 5'-TAACTGGTGAACATAAAATTGT CAC-3' using The Veriti Thermal Cycler (Applied Biosystems). The lowercase "a" in the forward primer is a mismatch (the nucleotide is G in the published sequence) that was specifically introduced to destroy an *MnII* site adjacent to and overlapping with the *MnII* site created by the G substitution at nucleotide 7271, thus allowing the 7271 nucleotide substitution to be detected by *MnII* digestion [52].

The PCR reaction was carried out to amplify *ATM* gene in a final volume of 25 μ L containing 10X reaction buffer, 25 mM MgCl₂, 5 mM dNTPs, 5 μ M primers, 500 U of Taq DNA polymerase, and 150 ng of genomic DNA. The PCR amplification conditions were as follows: 5 min at 94 °C, followed by 35 cycles of 20 s at 94 °C, 20 s at 55 °C, and 20 s at 72 °C, with a final extension step of 5 min at 72 °C. The PCR products were digested with the *MnII* restriction enzyme.

Thus, 10 μ L of PCR product was digested with 3 U of *MnII* restriction enzyme in a 20 μ L reaction with 1X reaction buffer and bovine serum albumin (0.1 mg/mL) at 37 °C overnight. The digested products were separated by electrophoresis in a 4.5% agarose gel containing ethidium bromide and visualized under UV illumination. Wild type allele resulted in 101 bp fragment, and variant allele resulted in 13 and 88 bp fragments. All fragments were observed for heterozygous genotype.

2.4. *ATM* IVS10-6T > G variant analysis

A PCR-RFLP assay was used to detect the *ATM* IVS10-6T > G variant using The Veriti Thermal Cycler (Applied Biosystems). A 193 bp PCR product was amplified using the following primers: Forward; 5'-ACAGCGAAACTCTGGCTCAA-3', Reverse; 5'-TGATCTT TTATTACTTCCCAGCCTAGT-3' in a final volume of 25 μ L as described above [52].

Cycling conditions were 94 °C for 4 min, followed by 35 cycles of 20 s of denaturing at 94 °C, 20 s at 53 °C, and 20 s of annealing

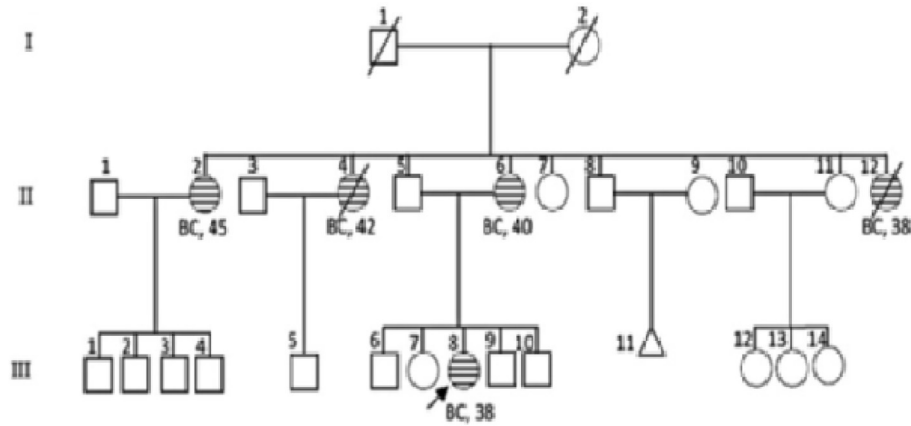

Fig. 1. Pedigree corresponding to one of the families included in the present study of *ATM* mutation in hereditary breast cancer. The index case is indicated with an arrow.

at 72 °C, with a final extension at 72 °C for 7 min. The PCR products were digested with the *RsaI* restriction enzyme.

Digestion was performed in a total volume of 20 μ l containing 10 μ l PCR product, 1X digestion buffer, 0.1 mg/mL BSA and 3U of *RsaI* by overnight incubation at 37 °C. The digested products were separated by electrophoresis on a 4.5% agarose gel staining with ethidium bromide, and the genotype was determined by the banding pattern observed. The variant allele was identified by the presence of 58 bp and 135 bp fragments, and the Wild type allele, which lacks a *RsaI* restriction site, was identified by a single 193-bp fragment. All fragments were observed for heterozygous genotype.

3. Results

In total, 163 breast cancer cases and 150 controls were successfully genotyped for the T7271G and IVS10–6T > G variants of the *ATM* gene using the PCR-RFLP technique. The baseline characteristics of the population sample including distribution of tumor characteristic such as histological grade and location of cancer were obtained from patients' medical records and listed in Table 1.

None of the 163 Moroccan breast cancer patients carried the *ATM* T7271G and IVS10–6T > G mutation. Moreover among the 163 cases, 40 patients had been screened for BRCA1 and BRCA2 mutations [54]. Thus, in the 30 patients who were non-BRCA mutation carriers, the analysis of T7271G and IVS10–6T > G mutation was also found negative.

4. Discussion

The *ATM* gene has long been hypothesized to be a breast cancer susceptibility gene, but the evidence has been contradictory. Most mutation analyses of *ATM* in patients with breast cancer and in control subjects have not found the increased frequency of mutations in case patients that would be expected if these mutations did predispose to breast cancer [32,33,37,42]. However, these studies have been limited by a lack of statistical power [55] and by the choice of method for mutation detection, most of which exclusively or preferentially detect protein-truncating mutations [56]. Furthermore, these studies have focused largely on patients with sporadic breast cancer, and few have tested for *ATM* mutations in multiple-case breast cancer families in which segregation between mutation and cancer can be examined [57].

In the present population-based case-control study, we evaluated for the first time the involvement of two *ATM* mutations, T7271G and IVS10–6T \rightarrow G, on breast cancer susceptibility in the

Table 1

Characteristics of individuals with breast cancer at time of diagnosis, screened for *ATM* c.7271T > G and c.1066–6T > G (IVS10–6T > G) mutations.

Characteristics	Samples
Cases/Controls	163/150
Age at diagnosis, mean \pm SD (years)	41 \pm 11
Range (years)	23–67
Menopausal Status	No. (%)
Premenopausal	85(52.14)
Postmenopausal	77(47.23)
Missing	1(0.61)
Estrogen receptor	
Positive	120 (73.61)
Negative	33 (20.24)
Missing	10 (6.13)
Progesterone receptor	
Positive	103 (63.19)
Negative	50(30.67)
Missing	10 (6.13)
Estrogen/Progesterone receptor	
ER ⁺ /PR ⁺	46 (28.22)
ER ⁺ /PR ⁻	34 (20.85)
ER ⁻ /PR ⁺	20 (12.26)
ER ⁻ /PR ⁻	63 (38.65)
Tumor size	
<2 cm	25 (15.33)
>2 cm	66 (40.49)
>5 cm	41(25.15)
Tumor of any size with extension	31 (19.01)
Histological grade	
1	22 (13.49)
2	95 (58.28)
3	46 (28.22)
Lymph node status	
Negative	65(39.87)
Positive	98 (60.12)
Distant metastases	
Negative	133(81.59)
Positive	30 (18.40)

Moroccan population. For this purpose, we performed a screening of those variants in 163 Moroccan breast cancer patients and 150 healthy controls. We found that none of the 313 analyzed samples carried the *ATM* T7271G and IVS10–6T \rightarrow G mutations, suggesting that the frequency of those variants is extremely low (or not present) in the Moroccan population.

Furthermore, the existence of two distinct classes of *ATM* mutations (truncating and missense) might explain some of the contradictory data on cancer risk. Some missense variants in *ATM* encode

Table 2
Studies investigating the frequency of T7271 G and IVS10–6T > G *ATM* gene variants in breast cancer cases and controls by ethnicity.

Variant	Study	Country	Year	Overall		Carriers n (frequency of carriers,%)		References	
				Case	Control	Case	Control		
T7271G	<i>Africa</i> Present study	MOROCCO	2016	163	150	0(0)	0(0)	Present study	
	<i>América</i> Bernstein and al	USA	2006	1110	1268	2 (0.2)	0 (0)	[47]	
	Bernstein and al	CANADA	2006	1195	1268	4 (0.3)	0 (0)	[47]	
	Szabo and al	CANADA	2004	43	–	0 (0)	–	[67]	
	Bernstein and al	USA	2003	511	638	0 (0)	1(0.2)	[70]	
	<i>Australia</i> Chenevix-Trench and al	AUSTRALIA	2002	525	381	1 (0.1)	0 (0)	[52]	
	<i>Europe</i> Szabo and al	THE NETHERLANDS	2004	501	184	0 (0)	0 (0)	[67]	
	Szabo and al	AUSTRIA	2004	87	91	0 (0)	0 (0)	[67]	
	Szabo and al	FRANCE	2004	209	–	0 (0)	–	[67]	
	Renwick and al	UNITED KINGDOM	2006	443	521	2(0.4)	0 (0)	[31]	
	IVS10–6T > G	<i>Africa</i> Present study	MOROCCO	2016	163	150	0(0)	0(0)	Present study
		<i>América</i> Bernstein and al	USA	2003	511	638	1 (0.2)	8 (1.3)	[70]
		Sommer and al	USA	2002	43	43	0 (0)	1(2.3)	[80]
		Bernstein and al	USA	2006	3757	1268	13(0.3)	10(0.8)	[47]
Szabo and al		CANADA							
		AUSTRALIA							
<i>Europe</i> Szabo and al		CANADA	2004	44	–	0 (0)	–	[67]	
Broeks and al		THE NETHERLANDS	2000	82	268	3(3.7)	2(0.7)	[38]	
Dork and al		GERMANY	2001	1000	500	7(0.7)	3(0.6)	[44]	
Szabo and al		THE NETHERLANDS	2004	621	452	6(0.9)	3(0.6)	[67]	
Szabo and al		AUSTRIA	2004	87	91	2(2.3)	1(1.1)	[67]	
Szabo and al		FRANCE	2004	209	–	0 (0)	–	[67]	
Lei and al		SWEDEN AND CZECH REPUBLIC	2002	768	557	2 (0.2)	1 (0.2)	[81]	
Broeks and al		THE NETHERLANDS	2003	233	268	3(1.3)	2(0.7)	[82]	
Soukupova and al		CZECH REPUBLIC	2008	161	183	1(0.6)	2(1.1)	[83]	
<i>Australia</i> Lindeman and al		AUSTRALIA	2004	495	725	7(1.4)	6 (0.8)	[79]	
Thompson and al		AUSTRALIA	2005	302	707	3(1.0)	7 (1.0)	[49]	
Chenevix-Trench and al		AUSTRALIA	2002	262	68	0 (0)	0 (0)	[52]	
Bernstein and al		USA	2006	3757	1268	13(0.3)	10(0.8)	[47]	
		CANADA							
	AUSTRALIA								

stable, but functionally abnormal proteins that could compete in complex formation with the normal *ATM* protein, resulting in a dominant-negative cellular phenotype and confer a particularly high risk of breast cancer when heterozygous, while causing a milder form of AT, when homozygous. In contrast, truncating mutations produce an unstable *ATM* protein so that heterozygote individuals still maintain 50% of wild type *ATM* activity, resulting in an almost normal phenotype [56,58]. The initial studies that examined the role of truncating *ATM* mutations and breast cancer risk failed to reveal statistically significant disease associations [33,59]. This was despite the evidence of excess breast cancer incidence within A-T families [34–37,42,60–64]. This apparent dichotomy between the results obtained with these two different study designs may simply reflect inadequate power rather than true disagreement [55]. However, an analysis of 20 missense *ATM* mutations provided little support for an association of *ATM* missense mutation and breast cancer [65]. Thompson et al. [63] also found no evidence for a difference in risk of breast or other cancer according to the type of *ATM* mutation, while the risk estimate of Renwick et al. [31] was based mainly on truncating mutations. Haplotype analysis could also reveal a role for common variants in the *ATM* gene in causing breast cancer. Five biallelic haplotype tagging sin-

gle nucleotide polymorphisms (SNPs) have been estimated to capture 99% of the haplotype diversity in Caucasian populations. In the Nurses Health Study, there was no evidence that common haplotypes of *ATM* are associated with breast cancer risk [66]. When confirmed, this could suggest that less common variation in *ATM* is involved in increasing breast cancer risk, which can only be addressed in much larger studies. A possible example of such a variant is the c.7271T > G (V2424G), with an allele frequency of approximately 0.2% among cases and a substantially elevated breast cancer risk [47,52,67] (Table 2).

The first variant studied, T7271G, was the only *ATM* mutation found in the A-T family reported by Stankovic et al. and is, therefore, likely to be pathogenic, although weakly so, because the three A-T case patients in this family had an atypically mild clinical phenotype. In the first of the families, two individuals homozygous for T7271G developed breast cancer at 44 and 50 years and their mother, an obligate carrier of the mutation, developed breast cancer at 82 years. In the second family, two brothers with ataxiatelangiectasia were compound heterozygotes for T7271G and a truncating mutation. Three paternal aunts of the brothers developed breast cancer in their 50s one of whom was confirmed to be a heterozygous T7271G carrier [48]. Subsequently, an Australian

family was reported in which five women with breast cancer were heterozygous T7271G carriers. Expression and activity analyses of *ATM* in cell lines from the carriers suggested that the mutation acts in a dominant negative activity [52]. This mutation has been shown to be very rare in several other studies [31,52,67,70]. The T7271G variant is predicted to result in a valine to glycine substitution at position 2424 of the *ATM* protein (p.Val2424Gly). While this substitution does not affect any readily-recognizable functional domain, programs such as SIFT [68] and PolyPhen [69], which attempt to classify mutations based on sequence conservation and structural prediction, suggest that this substitution is deleterious.

On the other hand, IVS10–6T → G *ATM* mutation has been detected in the homozygous state in one German patient with fullblown A-T [38,71]. This leaky splicing mutation appears to be the most common pathogenic *ATM* gene mutation at the population level, although it is infrequently compared with other *ATM* mutations in ataxia-telangiectasia patients [72,73] suggesting an incomplete penetrance with regard to classical A-T symptoms. In view of its population-wide frequency and its ancient origin, together with its impairment of *ATM* function and its linkage with breast cancer, the IVS10–6T > G mutation may constitute one of the most common inherited susceptibility loci. This variant had been demonstrated to affect normal splicing of exon 11 and exon skipping, resulting in a frame shift starting at codon 355 and subsequent truncation of the protein at amino acid 419 (Table 2).

Our results thus refute those of Chenevix-Trench et al. [52] who proposed that the *ATM* IVS10–6T > G and 7271T > G mutations are high-risk breast cancer-susceptibility alleles. They based their estimates of the breast cancer risks conferred by these two mutations on only 2 and 1 single family, respectively, together including 14 cases with breast cancer. The total likelihood of disequilibrium score for linkage of breast cancer to the *ATM* locus from these three families was 1.18 (odds of 15:1 in favor of linkage), which does not meet conventional criteria for significant linkage. Given the relatively little linkage information/family (likelihood of disequilibrium scores of 0.14, 0.64, and 0.40), precise estimates of the breast cancer risks conferred by the two mutations could not be derived from their dataset, and hence, their Bayes factors should be viewed with caution. Combining the Bayes factors reported for the two Australian *ATM* IVS10–6T > G-positive families [52] with those of the 5 families in this study gives total Bayes factors of 0.04 (LCIS case classified as unaffected) and 0.0025 (LCIS case classified as affected). These results imply overall odds of 25:1 and 400:1 against causality, respectively. The expectation that many of the breast cancer-susceptibility alleles yet to be identified will confer low breast cancer risks [74] underlines the need for stringent thresholds of statistical significance, large sample sizes, and independent replication before results should be considered convincing [75,76].

5. Conclusion

Our data do not support an increased breast cancer risk for the *ATM* IVS10–6T > G mutation, although a slightly increased risk cannot be formally excluded. Neither the *ATM* IVS10–6T > G mutation nor the *ATM* 7271T > G mutation is likely to have a substantial contribution to familial breast cancer. No evidence currently exists that any mutation of the *ATM* gene confers a high risk of breast cancer [35,33,38,44,48,52,62]. In contrast to others [77,78], we believe that carrier screening in clinical settings for the purpose of breast cancer risk assessment is as yet not indicated for any *ATM* allele. However, a role for the *ATM* gene in breast cancer susceptibility is plausible but the exact association remains unclear,

and most probably comprises only a modest role in familial breast cancer susceptibility.

Conflict of interest

We have no conflict of interest to declare.

References

- [1] Boder E. Ataxia-telangiectasia: an overview. In: Gatti RA, editor. *Ataxia-telangiectasia: genetics, neuropathology and immunology of a degenerative disease of childhood*. New York: Alan R. Liss; 1985. p. 1–63.
- [2] Gatti RA, Boder E, Vinters HV, Sparkers RS, Norman A, Lange. *Ataxia-telangiectasia: an interdisciplinary approach to pathogenesis*. Medicine (Baltimore) 1991;70:99–117.
- [3] Segdwick RP, Boder E. Ataxia-telangiectasia. In Vianney De Jong JMB, editors. *Hereditary neuropathies and spinocerebellar atrophies*. Amsterdam: Elsevier Science Publishers, 1991. p. 347–423.
- [4] Easton DF. Cancer risks in A-T heterozygotes. *Int J Radiat Biol* 1994;66: S177–82.
- [5] Shiloh Y. Ataxia-telangiectasia: closer to unravelling the mystery. *Eur J Hum Genet* 1995;3:116–38.
- [6] Savitsky K, Bar-Shira A, Gilad S, Rotman G, Ziv Y, Vanagaite L, et al. A single ataxia telangiectasia gene with a product similar to PI-3 kinase. *Science* 1995;268(5218):1749–53.
- [7] Lavin MF, Shiloh Y. Ataxia-telangiectasia: a multifaceted genetic disorder associated with defective signal transduction. *Curr Opin Immunol* 1996;8:459–64.
- [8] Lavin MF, Shiloh Y. The genetic defect in ataxia-telangiectasia. *Annu Rev Immunol* 1997;15:177–202.
- [9] Gatti RA. Ataxia-telangiectasia. In: Vogelstein B, Kinzler KW, editors. *The genetic basis of human cancer*. McGraw-Hill: New York; 2002. p. 239–66.
- [10] Chun HH, Gatti RA. DNA repair (Amsterdam) 2004;3:1187–96.
- [11] Taylor AM, Byrd PJ. *J Clin Pathol* 2005;58:1009–15.
- [12] Ahmed M, Rahman N. ATM and breast cancer susceptibility. *Oncogene* 2006;25(43):5906–11.
- [13] Ambrose M, Gatti RA. Pathogenesis of ataxia-telangiectasia: the next generation of ATM functions. *Blood* 2013;121(20):4036–45.
- [14] Abraham RT. PI 3-kinase related kinases: 'big' players in stress-induced signaling pathways. *DNA Repair (Amst)* 2004;3:883–7.
- [15] Derheimer FA, Kastan MB. Multiple roles in monitoring and maintaining DNA integrity. *FEBS Lett* 2010;584:3675–81.
- [16] Shiloh Y, Ziv Y. The ATM protein kinase: regulating the cellular response to genotoxic stress, and more. *Mol Cell Biol* 2013;14:197–210.
- [17] Uziel T, Savitsky K, Platzer M, Ziv Y, Helbitz T, Nehls M, et al. Genomic organization of the ATM gene. *Genomics* 1996;33:317–20.
- [18] Platzer M, Rotman G, Bauer D, Uziel T, Savitsky K, Bar-Shira A, et al. Ataxia telangiectasia locus: sequence analysis of 184 kb of human genomic DNA containing the entire ATM gene. *Genome Res* 1997;7:592–605.
- [19] Gatti RA, Berkel I, Boder E, Braedt G, Charmley P, Concannon P, et al. Localization of an ataxia telangiectasia gene to chromosome 11q22–23. *Nature* 1988;336:577–80.
- [20] Shiloh Y, Kastan MB. ATM: genome stability, neuronal development, and cancer cross paths. *Adv Cancer Res* 2001;83:209–54.
- [21] Angele S, Hall J. The ATM gene and breast cancer: is it really a risk factor? *Mutat Res* 2000;462:167–78.
- [22] Negrini M, Rasio D, Hampton GM, Sabbioni S, Rattan S, Carter SL, et al. Definition and refinement of chromosome 11 regions of loss of heterozygosity in breast cancer: identification of a new region at 11q23.3. *Cancer Res* 1995;55:3003–7.
- [23] Laake K, Launonen V, Niederacher D, Gudlaugsdottir S, Seitz S, Rio P, et al. Loss of heterozygosity at 11q23.1 and survival in breast cancer: results of a large European study. *Breast Cancer Somatic Genetics Consortium*. *Genes Chromosomes Cancer* 1999;25:212–21.
- [24] Hampton GM, Mannermaa A, Winqvist R, Alavaikko M, Blanco G, Taskinen PJ, et al. Loss of heterozygosity in sporadic human breast carcinoma: a common region between 11q22 and 11q23.3. *Cancer Res* 1994;54:4586–9.
- [25] Carter SL, Negrini M, Baffa R, Gillum DR, Rosenberg AL, Schwartz GF, et al. Loss of heterozygosity at 11q22–q23 in breast cancer. *Cancer Res* 1994;54:6270–4.
- [26] Broeks A, Braaf LM, Huseinovic A, Schmidt MK, Russell NS, van Leeuwen FE, Hogervorst FB, van't Veer LJ. The spectrum of ATM missense variants and their contribution to contralateral breast cancer. *Breast Cancer Res Treat* 2008; 107:243–248.
- [27] Pippard EC, Hall AJ, Barker DJ, Bridges BA. Cancer in homozygotes and heterozygotes of ataxia-telangiectasia and xeroderma pigmentosum in Britain. *Cancer Res* 1988;48:2929–32.
- [28] Swift M, Chase C, Morrell D. Cancer predisposition of Ataxia-Telangiectasia heterozygotes. *Cancer Genet Cytogenet* 1990;46:21–7.
- [29] Thompson D, Duedal S, Kirner J, McGuffog L, Last J, Reiman A, et al. Cancer risks and mortality in heterozygous ATM mutation carriers. *J Natl Cancer Inst* 2005;97:813–22.
- [30] Hall J. The Ataxia-telangiectasia mutated gene and breast cancer: gene expression profiles and sequence variants. *Cancer Lett* 2005;227:105–14.

- [31] Renwick A, Thompson D, Seal S, Kelly P, Chagtai T, Ahmed M, et al. ATM mutations that cause ataxia-telangiectasia are breast cancer susceptibility alleles. *Nat Genet* 2006;38:873–5.
- [32] Vorechovsky I, Rasio D, Luo LP, et al. The ATM gene and susceptibility to breast cancer: analysis of 38 breast tumors reveals no evidence for mutation. *Cancer Res* 1996;56:2726–32.
- [33] FitzGerald MG, Bean JM, Hegde SR, et al. Heterozygous ATM mutations do not contribute to early onset of breast cancer. *Nat Genet* 1997;15:307–10.
- [34] Swift M, Reitnauer PJ, Morrell D, Chase CL. Breast and other cancers in families with ataxia-telangiectasia. *N Engl J Med* 1987;316:1289–94.
- [35] Swift M, Morrell D, Massey RB, Chase CL. Incidence of cancer in 161 families affected by ataxia-telangiectasia. *N Engl J Med* 1991;325:1831–6.
- [36] Inskip HM, Kinlen LJ, Taylor AM, Woods CG, Arlett CF. Risk of breast cancer and other cancers in heterozygotes for ataxia-telangiectasia. *Br J Cancer* 1999;79:1304–7.
- [37] Athma P, Rappaport R, Swift M. Molecular genotyping shows that ataxiatelangiectasia heterozygotes are predisposed to breast cancer. *Cancer Genet Cytogenet* 1996;92:130–4.
- [38] Broeks A, Urbanus JH, Floore AN, Dahler EC, Klijn JG, Rutgers EJ, et al. ATM-heterozygous germline mutations contribute to breast cancer-susceptibility. *Am J Hum Genet* 2000;66:494–500.
- [39] Milne RL. Variants in the ATM gene and breast cancer susceptibility. *Genome Med* 2009;1.
- [40] Savitsky K, Sfez S, Tagle DA, Ziv Y, Sarti A, Collins FS, et al. The complete sequence of the coding region of the ATM gene reveals similarity to cell cycle regulators in different species. *Hum Mol Genet* 1995;4:2025–32.
- [41] Fletcher O, Johnson N, dos Santos Silva I, Orr N, Ashworth A, Nevanlinna H, et al. Missense variants in ATM in 26,101 breast cancer cases and 29,842 controls. *Cancer Epidemiol Biomarkers Prev* 2010;19:2143–51.
- [42] Izatt L, Greenman J, Hodgson S, Ellis D, Watts S, Scott G, et al. Identification of germline missense mutations and rare allelic variants in the ATM gene in early onset breast cancer. *Genes Chromosomes Cancer* 1999;26:286–94.
- [43] Teraoka SN, Malone KE, Doody DR, Suter NM, Ostrander EA, Daling JR, et al. Increased frequency of ATM mutations in breast carcinoma patients with early onset disease and positive family history. *Cancer* 2001;92:479–87.
- [44] Dork T, Bendix R, Bremer M, Rades D, Klopffer K, Nicke M, et al. Spectrum of ATM gene mutations in a hospital-based series of unselected breast cancer patients. *Cancer Res* 2001;61:7608–15.
- [45] Sommer SS, Jiang Z, Feng J, Buzin CH, Zheng J, Longmate J, et al. ATM missense mutations are frequent in patients with breast cancer. *Cancer Genet Cytogenet* 2003;145:115–20.
- [46] Thorstenson YR, Roxas A, Kroiss R, Jenkins MA, Yu KM, Bachrich T, et al. Contributions of ATM mutations to familial breast and ovarian cancer. *Cancer Res* 2003;63:3325–33.
- [47] Bernstein JL, Teraoka S, Southey MC, Jenkins MA, Andrulis IL, Knight JA, et al. Population-based estimates of breast cancer risks associated with ATM gene variants c.7271T > G and c.1066-GT > G (IVS10-6T > G) from the Breast Cancer Family Registry. *Hum Mutat* 2006;27:1122–8.
- [48] Stankovic T, Kidd A, Sutcliffe A, McGuire G, Robinson P, Weber P, et al. ATM mutations and phenotypes in ataxia-telangiectasia families in the British Isles: expression of mutant ATM and the risk of leukemia, lymphoma, and breast cancer. *Am J Hum Genet* 1998;62:334–45.
- [49] Thompson D, Antoniou AC, Jenkins M, Marsh A, Chen X, Wayne T, et al. KConFab Investigators. Two atm variants and breast cancer risk. *Hum Mutat* 2005;25(6):594–5.
- [50] Oldenburg RA, Meijers-Heijboer H, Cornelisse CJ, Devilee P. Genetic susceptibility for breast cancer: how many more genes to be found? *Crit Rev Oncol Hematol* 2007;63(2):125–49.
- [51] Tavtigian SV, Oefner PJ, Babikyan D, Hartmann A, Healey S, Le Calvez-Kelm F, et al. Rare, evolutionarily unlikely missense substitutions in atm confer increased risk of breast cancer. *Am J Hum Genet* 2009;85(4):427–46.
- [52] Chenevix-Trench G, Spurdle AB, Gatei M, Kelly H, Marsh A, Chen X, et al. Dominant negative ATM mutations in breast cancer families. *J Natl Cancer Inst* 2002;94:205–15.
- [53] Miller SA, Dykes DD, Polesky HF. A simple salting out procedure for extracting DNA from human nucleated cells. *Nucl Acids Res* 1988;16:1215.
- [54] Tazzite A, Jouhadi H, Nadifi S, Aretini P, Falaschi E, Collavoli A, et al. Caligo MA (2012) BRCA1 and BRCA2 germline mutations in Moroccan breast/ ovarian cancer families: novel mutations and unclassified variants. *Gynecol Oncol* 2012;125:687–92.
- [55] Bishop DT, Hopper J. AT-tributable risks? [news]. *Nat Genet* 1997;15:226.
- [56] Gatti RA, Tward A, Concannon P. Cancer risk in ATM heterozygotes: a model of phenotypic and mechanistic differences between missense and truncating mutations. *Mol Genet Metab* 1999;68:419–23.
- [57] Vorechovsky I, Luo L, Lindblom A, Negrini M, Webster AD, Croce CM, et al. ATM mutations in cancer families. *Cancer Res* 1996;56:4130–3.
- [58] Meyn MS. Ataxia-telangiectasia, cancer and the pathobiology of the ATM gene. *Clin Genet* 1999;55:289–304.
- [59] Bebb DG, Yu Z, Chen J, Telatar M, Gelmon K, Phillips N, et al. Absence of mutations in the ATM gene in forty-seven cases of sporadic breast cancer. *Br J Cancer* 1999;80:1979–81.
- [60] Borresen A-L, Andersen TI, Tretli S, Heiberg A, Moller P. Breast cancer and other cancers in Norwegian families with Ataxia Telangiectasia genes. *Genes Chromosomes Cancer* 1990;2:339–40.
- [61] Janin N, Andrieu N, Ossian K, Lauge A, Croquette MF, Griscelli C, et al. Breast cancer risk in ataxia telangiectasia (AT) heterozygotes: haplotype study in French AT families. *Br J Cancer* 1999;80:1042–5.
- [62] Olsen JH, Hahnemann JM, Borresen-Dale AL, Brondum-Nielsen K, Hammarstrom L, Kleinerman R, et al. Cancer in patients with ataxiatelangiectasia and in their relatives in the Nordic countries. *J Natl Cancer Inst* 2001;93:121–7.
- [63] Thompson D, Duedal S, Kirner J, McGuffog L, Last J, Reiman A, et al. Cancer risks and mortality in heterozygous ATM mutation carriers. *J Natl Cancer Inst* 2005;97:813–22.
- [64] Geoffroy-Perez B, Janin N, Ossian K, Lauge A, Croquette MF, Griscelli C, et al. Cancer risk in heterozygotes for ataxia-telangiectasia. *Int J Cancer* 2001;93:288–93.
- [65] Bretsky P, Haiman CA, Gilad S, et al. The relationship between twenty missense ATM variants and breast cancer risk: the multiethnic cohort. *Cancer Epidemiol Biomarkers Prev* 2003;12:733–8.
- [66] Tamimi RM, Hankinson SE, Spiegelman D, Kraft P, Colditz GA, Hunter DJ. Common ataxia telangiectasia mutated haplotypes and risk of breast cancer: a nested case-control study. *Breast Cancer Res* 2004;6:R416–22.
- [67] Szabo CI, Schutte M, Broeks A, et al. Are ATM mutations 7271T → G and IVS10-6T → G really high-risk breast cancer-susceptibility alleles? *Cancer Res* 2004;64:840–3.
- [68] Ng PC, Henikoff S. Accounting for human polymorphisms predicted to affect protein function. *Genome Res* 2002;12:436–46.
- [69] Sunyaev S, Ramensky V, Koch I, Lathe III W, Kondrashov AS, Bork P. Prediction of deleterious human alleles. *Hum Mol Genet* 2001;10:591–7.
- [70] Bernstein JL, Bernstein L, Thompson WD, Lynch CF, Malone KE, Teitelbaum SL, et al. *Br J Cancer* 2003;89:1513–6.
- [71] Dork T, Nicke M, Klopffer K, Bendix R, Stuhmann M, Bremer M, et al. Frequent splicing mutation of the ATM gene in breast cancer. *Am J Hum Genet* 1999;65 (suppl):A124.
- [72] Broeks A, de Klein A, Floore AN, Muijtjens M, Kleijer WJ, Jaspers NG, et al. ATM germline mutations in classical ataxia-telangiectasia patients in the Dutch population. *Hum Mutat* 1998;12:330–7.
- [73] Sandoval N, Platzer M, Rosenthal A, Dörk T, Bendix R, Skawran B, et al. Characterization of ATM gene mutations in 66 ataxia-telangiectasia families. *Hum Mol Genet* 1999;8:69–79.
- [74] Antoniou AC, Pharoah PD, McMullan G, Day NE, Ponder BA, Easton D. Evidence for further breast cancer susceptibility genes in addition to BRCA1 and BRCA2 in a population-based study. *Genet Epidemiol* 2001;21:1–18.
- [75] Editorial. Freely associating. *Nat. Genet.* 1999; 22: 1–2.
- [76] Dahlman I, Eaves IA, Kosoy R, Morrison VA, Heward J, Gough SC, et al. Parameters for reliable results in genetic association studies in common disease. *Nat Genet* 2002;30:149–50.
- [77] Finkel E. Consortium piecing together role of ATM gene in breast cancer. *J Natl Cancer Inst* 2002;94:158–9.
- [78] Concannon P. ATM heterozygosity and cancer risk. *Nat Genet* 2002;32:89–90.
- [79] Lindeman GJ, Hiew M, Visvader JE, Leary J, Field M, Gaff CL, et al. Frequency of the ATM IVS10-6T → G variant in Australian multiple-case breast cancer families. *Breast Cancer Res* 2004;6:R401–7.
- [80] Sommer SS, Buzin CH, Jung M, Zheng J, Liu Q, Jeong SJ, et al. Elevated frequency of ATM gene missense mutations in breast cancer relative to ethnically matched controls. *Cancer Genet Cytogenet* 2002;134:25–32.
- [81] Lei H, Hospisilova D, Lindblom A, Vorechovsky I. Dominant negative ATM mutations in breast cancer families. *J Natl Cancer Inst* 2002;94:951–2.
- [82] Broeks A, Urbanus JH, de Knijff P, Devilee P, Nicke M, Klöpffer K, et al. IVS10-6T > G, an ancient ATM germline mutation linked with breast cancer. *Hum Mutat* 2003;21:521–8.
- [83] Soukupova J, Dundr P, Kleibl Z, Pohlreich P. Contribution of mutations in ATM to breast cancer development in the Czech population. *Oncol Rep* 2008;19 (6):1505–10.