

# Design of a Lightning Protection System for an Overhead 3 kV DC Electrified Railway Line: A Case Study from South Africa

Kelishia Radhalal<sup>1</sup>, Chandima Gomes<sup>2</sup>

<sup>1,2</sup>School of Electrical and Information Engineering, University of the Witwatersrand Johannesburg, South Africa

---

## Article Info

### Article history:

Received Dec 25, 2020

Revised Apr 16, 2021

Accepted Jun 4, 2021

---

### Keyword:

DC Railway  
system damage  
Lightning current  
Surge protection  
Transient Response

---

## ABSTRACT

A protection scheme is proposed for the 3 kV DC railway, in Kwa-Zulu Natal province, a region with a high lightning occurrence density. The surge protection was sought by implementing three metal-oxide surge arresters and an overhead ground wire. The purpose of these arresters is determined by their location in the circuit and the points that are vulnerable to adverse lightning effects: an arrester is installed to protect insulators between overhead lines and the supporting metallic mast, an arrester is installed to protect the point of contact between a stationary power supply wire and the train, and an arrester is installed to protect apparatus associated with the running tracks (return rail). An isolated earthing system is explored, and the effects of surge impedances and footing resistances are discussed. The voltage dropped across relevant vulnerable components and energy absorbed by the system components are determined by the simulation software Simulink. Lightning currents are injected into the system using Heidler function where the parameters comply with lightning protection standards. It is observed that the protection mechanisms defend susceptible components to a specified level. This demonstrates the success of the design in accordance with arrester protection levels (73.3 kV) and equipment withstand capabilities (a basic insulation level of 143 kV). This offers a protection margin of 95%. The largest percentage overshoot in the system is 39%, and this value is substantiated using reflection phenomena.

Copyright © 2021 Institute of Advanced Engineering and Science.  
All rights reserved.

---

## Corresponding Author:

Kelishia Radhalal,  
School of Electrical and Information Engineering,  
University of the Witwatersrand, Johannesburg, South Africa  
Email: 1319092@students.wits.ac.za

---

## 1. INTRODUCTION

The electrification of railway systems reduces operational costs since there is less track wear with decreased fuel costs and carbon dioxide emissions, in comparison to heavy diesel engines, which are not environmentally sustainable [1]. These traction systems require robust infrastructure – drawing large investments to ensure the transport mechanisms are dependable. A component of this infrastructure is over-voltage protection in the electrical supply of the train's rails. These over-voltages often result from switching operations and lightning surges. In South Africa, due to the high ground flash density, lightning impulses pose a significant threat to the safety of railway systems. Thus, protection mechanism designs for these over voltages are required to regulate these surges to a permissible and safe value for the equipment's insulation.

Although several studies have been done in the literature in addressing lightning protection of railway systems, not much has made their focus on 3kV DC systems and the geographical uniqueness of the region of concern of this study, in South Africa. Thus, the primary objective of this work is to achieve an appropriate protection level of the focused 3 kV DC traction system through the use of surge arresters, an overhead ground wire and isolated earthing.

In South Africa, there are two main lines that transport resources in mass, namely the iron ore and coal lines [2]. Both of these lines are classified as heavy haul, due to their high axle load profile. This also means that the speed of the trains is lower. The coal line is electrified using both 3 kV DC and 25 kV AC supply networks, depending on the axle loading required [3]. KZN has numerous 3 kV DC coal-carrying lines. It is to be noted that this paper is formulated considering a low-capacity coastal coal line, which has lower axle loading than the iron ore line. The railway under consideration is the Transnet KZN route, which carries coal with electrification at 3 kV DC. Coal is employed in the generation of 93% of South Africa's electricity, making it an integral component of the economy and society.

The lightning current is represented in IEC 62305-1 [4] by the type of stroke: the positive stroke which typically has a long tail, by 10/350  $\mu$ s, the first negative short-stroke by 1/200  $\mu$ s and the negative subsequent stroke by 0.25/100  $\mu$ s. Note that although the positive stroke has the highest allocated peak currents, the negative current, especially the negative subsequent strokes poses the highest risk of induced over-voltages that could be harmful, due to the fast-rising edge. However, in this study, as our focus is direct strikes we confined only to the positive stroke, which could dissipate a significant amount of energy in victimized equipment [5, 6].

Some of the highest lightning activity occurs at the border between KZN and Mpumalanga, with a ground flash density of approximately 14 - 23 flashes/km<sup>2</sup>/yr [7]. The coastal region of the province exhibits slightly reduced activity, of about 5 - 7 flashes/km<sup>2</sup>/yr [7]. The reason for this may be attributed to the elevation of the mountain range at the province's border, as well as the natural trends of superstorm cell development. The South African power company, Eskom, attributes numerous trip-outs in this region to these factors. This provides a clear indication that the region has a high lightning occurrence density. Furthermore, the ground stroke density at the border and coastal region is 42 – 66 strokes/ km<sup>2</sup>/yr and 6 - 21 strokes/ km<sup>2</sup>/yr respectively [7]. Such figures represent one of the highest lightning densities in the world, in this region, which justifies the requirement of this study. The median peak current of the strokes in the region is approximately 15 kA [8]. Gijben [8] also indicates that the positive lightning in some hot spots of Kwa-Zulu Natal could reach figures as high as 4 flashes/km<sup>2</sup>/yr, reconfirming that this is a region with one of the most affected landscapes in the world concerning lightning effects.

The termination of lightning either directly or indirectly results in over-voltages and currents being superimposed on normal operating conditions of equipment. These two main sources of over-voltages in the equipment occur from a direct flash to a structure or a flash near a structure (that causes induced over-voltages). These transient over-voltages may bypass the insulation between overhead feeder lines and supporting masts – ultimately causing insulators to flashover and direct all energy to an earthing system (assuming the mast is adequately grounded). This would cause a loss of power to the rest of the system since the over-voltage is superimposed on routine conditions. Therefore, the power in that segment (and consecutive segments) of the railway will no longer be electrified and trains will likely halt. The air around the insulation is also likely to remain ionized, encouraging follow-through currents even after the surge has ended. This effectively drains the normal operational energy of the system to the ground after the lightning strike has completed. Notably, a similar condition can occur if the footing impedance of the mast is unreasonably high. If the insulation is regularly bypassed during surges (and potentially normal operations), the ageing of the device will accelerate – thereby causing it to become ineffective rapidly after maintenance or initial installation. This can be attributed to the accumulative effect which may lead to premature failure of the insulation. This presents as an expense since the insulation material will need to be replaced while the line is not active and experts will be required to facilitate this.

Notably, the existing surge protection solutions reduce the likelihood of direct lightning attachment to critical components of a system. However, they do not provide a solution for lightning strikes that bypass them and are injected into the system. This compels the design of a system that prevents the effects of lightning strikes or the induced electromagnetic fields that cause superimposed transient over-voltages.

Until the 1980's, electrical supply systems were typically outfitted with spark-gap arresters [9]. These components are comprised of silicon carbide-based resistors and spark gaps – connected in series with each other. They were also assembled in porcelain housing. However, this configuration has disadvantages: over-voltages are limited by the ignition voltage of the spark gap exclusively. This yields a response voltage that is proportional to the incoming wave's front steepness – essentially, steep pulses will bypass the arrester protection level [9]. Lightning impulses may have a front time that rises so rapidly that the arrester will not provide adequate over-voltage protection. This would lead to equipment damage in the railway network and its components. An added disadvantage of this arrester is the potential for housing flashover occurrences due to pollution in the porcelain. This could yield an undesirable external leakage current [10].

Additionally, if the spark-gap arresters are connected in parallel, only one arrester will be activated in the presence of a transient overvoltage (the arrester with the lowest response voltage). This restricts the level of the incident over-voltage to a value below the ignition voltage of subsequent arresters [9]. Therefore, their

response is muted. This limits the potential to distribute incident energy to multiple arresters and deposits this high level of energy on a single arrester, which can erode its performance due to the continued application of voltage stresses. Moreover, there is a follow-through current present after the response has been ignited (and the over-voltage has been limited). This means that the arrester absorbs a significant amount of energy, which could lead to performance issues. This energy is likely to be partly radiated as heat, effectively increasing the temperature of the equipment. The application of repetitive pulse stresses may lead to premature insulation failure, as cited in [9, 10, 11].

At present, the protection designs for a railway system is usually done as per the vendor specifications of the protective components. However, in regions of high ground flash density such as Eastern parts of South Africa, and most other parts of Southern, Central and Sub-Saharan West Africa, these vendors specified lightning protection system fails due to inadequacy of the level of protection. On the other hand, overestimation of the risk may incur heavy financial expenses due to over protection. Such drawbacks could be eliminated by designing system-specific lightning protection measures through appropriate simulation, where statistically significant parameters of lightning currents in the region are considered. This paper proposes, a feasible simulation method of selecting lightning protection components and their installation locations, and evaluating the level of protection of the designed system. The design takes into account many possibilities of shielding and insulation failure scenarios to ensure that all possible avenues breaching the defence of the electrical safety by lightning transients are covered.

## 2. METHODOLOGY

The design procedure employed observes standards and addresses protection measures to reduce the failure of electronic and electrical systems, as well as to mitigate physical damage. The main LPS components are discussed, and the model of the system is presented. The choice of components is substantiated using literature and the Heidler function and its applicability to this research is discussed. Finally, the performance success criteria are addressed.

An LPS is generally comprised of air terminals (as aforementioned), down-conductors, bonding and grounding systems, surge protective devices (SPDs) and inspection, maintenance, and testing procedures. Air terminals may or may not collect a strike. If the air terminal collects a strike, the down-conductor is employed to ensure the collected strike's conduit to the ground is well-established. If it does not, then the SPD conducts the transient over-voltage to the ground, defending critical system operations. Bonding ensures equipotential connectivity of all metallic objects. This prevents voltage mismatches that would render the protection system unreliable.

The sources of lightning-based damage to a structure are outlined in Section 5.1.2 of SANS 62305-1. The overhead traction system LPS is designed according to the point of strike: flashes to the overhead ground wire, as well as to the catenary and contact lines, and to the return rails. A flash near a conductor is assumed to be close enough to be considered a flash to the conductor, due to the high probability of induced over-voltages resulting from the flash. These points of strike are important as they determine where MOAs should be placed to reduce the failure of the railway's electronic and electrical systems. A thorough analysis of flashes to the mast is considered out of scope for this research since it is assumed that the mast will be satisfactorily insulated and earthed. However, the footing resistance of the mast is still considered in the system to briefly observe the effect of a flash on the mast.

The MOA for the 3 kV DC traction supply is connected between an overhead feeder wire and overhead ground wire. This protects insulators between feeder wires and the mast. This configuration is initially outlined in [12], and is considered a safe solution because the highest part of the traction system is the overhead ground wire. It, therefore, intercepts the majority of lightning strikes [13] and the over-current is not conveyed to the lines but to ground through the earthed masts. Additionally, the implementation of this overhead ground wire means that the arresters will be subjected to partial lightning currents only. The majority of the lightning current is conducted to ground via the earthed supporting structures (masts). An additional arrester is implemented between the contact wire and an isolated earthing system. This protects the contact point between the supply and electric locomotive from over-voltages. Hence, the main function of these arresters is insulation coordination and ensuring the insulators are protected against damage, as well as protection of the pantograph on the train. Essentially, this MOA offers over-voltage protection to the equipment connected to the traction power supply. An MOA is also connected between the return rails and an isolated earthing system. This offers

over-voltage protection to equipment connected to the running rails. This is depicted in Figure 1. In total, there are three surge arresters in this segment of the traction system. The selection procedure for a surge arrester is outlined below.

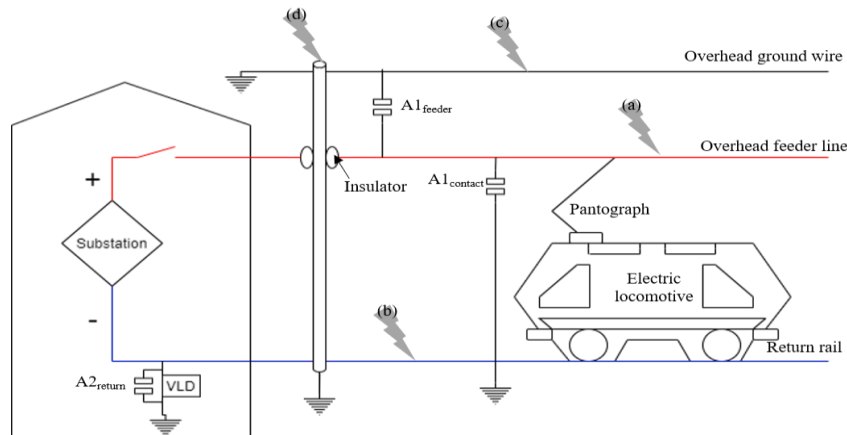

Figure 1. Arrester placement in simplified overhead catenary system (a) lightning strike to the feeder line, either close to the catenary line or the pantograph, (b) lightning strike to the return rails, (c) lightning strike to the overhead ground wire of the LPS and (d) lightning strike to the supporting metallic mast

Since the temporary over-voltages in the system are unknown, it is assumed that the earthing system is non-effective. Moreover, the characteristics of all possible over-voltages in the system are not known. Hence, a decision must be made regarding the arrester voltage protection level,  $U_p$ . Various typical basic insulation level (BIL) values are extracted from existing traction systems. The minimum and maximum of these values are 90 and 185 kV respectively. Using a protection margin of 95%, the arrester protection level is 47.38 and 94.87 kV for these BIL values. This is obtained using (1). However, the BIL of the entire system is not known. Therefore, these protection levels are plotted to observe their effect on protection margins at various BILs, shown in Figure 2. The lower protection level presents an unrealistic margin and the higher level presents an undesirably low margin. It is decided that the BIL of the system is best set at the median value of 143 kV. This results in an arrester protection level of 73.3 kV.

$$Protection\ margin\ \% = \frac{BIL}{U_p - 1} \tag{1}$$

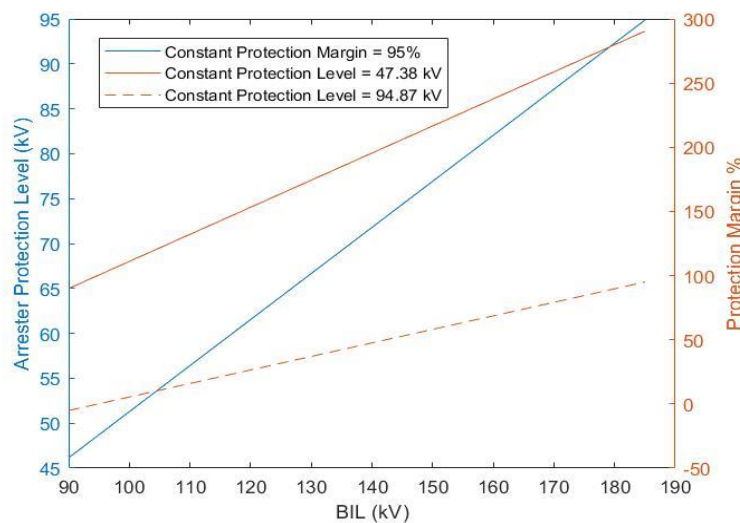

Figure 2. Relationship between BIL and varying constant protection levels and protection margins

Lightning termination on the overhead ground wire is favoured over termination on a feeder line. This would conduct the transient over-voltage to an earthing system (shared with the surge arresters that protect the

insulators and train). Notably, if the footing resistance is too high, then a back-flashover of the insulators may occur. This facilitates the design of an isolated earthing system. Essentially, the mast's foundation earthing is isolated from that of the overhead lines. This would reduce the propensity of back-flashover and induced over-voltages in other metallic structures.

In the case of the overhead ground wire not intercepting the lightning strike, a shielding failure occurs. This is because the overhead ground wire acts as a horizontal air-termination device. The additional purpose of this wire is to ensure that the masts are interconnected and locally grounded. If a lightning strike terminates on this wire, it separates into two transient over-currents traveling in opposite directions from the point of contact. Hence, these currents can be grounded by multiple masts, instead of a single mast. This is important as a single mast may have multiple reflected over-voltages, that could contribute to back-flashovers across insulators. Moreover, the conduction of a single, high-current transient over-voltage to the ground may establish an electrical potential between the mast's ground and that of adjacent metallic structures – contributing to stray currents and electrochemical corrosion.

There have been numerous investigations conducted into overhead ground wires and their applications in LPSs. [14] indicates that the installation of an overhead ground wire is significantly more effective in preventing damage to a system's surge arresters than enhancing the withstand capabilities of the arrester. This is actually stated to be twice as effective. These results are substantiated by the reduced energy absorption of the arrester in the presence of an overhead ground wire, by an average factor of 4 [14].

The feeder substation is modelled using a transformer (to step down the voltage to 3 kV) and rectifier circuit (to convert AC from the national utility grid to DC to be used by the train). Hereafter, the catenary wire and contact wire are modelled as transmission lines in parallel. This is because they are simultaneously live. The insulators between the mast and feeder wires are modelled as switches in parallel with an effective stray ground capacitance. This is because the insulator will flashover after a threshold voltage is surpassed, acting like a closed switch (it is open if this does not occur). The mast footing resistance is determined using control functions. This ensures an accurate overall model is obtained. The DC motors for the electric locomotive are supplied from the contact wire and connected to the substation's foundation ground via the return rails and VLDs. The MOAs are modelled according to the IEEE Working Group 3.4.11 model. This is because it is a frequency-dependent model (which becomes important during high-frequency lightning surges) and it models the physical parameters of the device. A VLD is modelled using anti-parallel diodes between the return rail and substation foundation ground, with the function of preventing impermissibly high touch voltages. An overview of the simulation model is given in Figure 3.

Lightning current models are used in various research fields and are particularly significant in the design of Lightning Protection Systems (LPSs). These models are essential tools in analysing the effect of lightning discharges' electric and magnetic fields on equipment. The Heidler function is a standard lightning model which can have tailored parameters to achieve a desirable waveform for a single stroke. This model is used preferentially over the double-exponential model as it conveys a more realistic waveform and has an acceptable first derivative at the moment of zero time [15]. Essentially, there is an instantaneous current increase at zero-time in the double-exponential model, which is not physically feasible. Additionally, this model does not faithfully generate waveforms that are compliant with IEC 62305-1 Table A.1, potentially hindering the reliability of the entire system [16]. However, the Heidler function does present its disadvantages: the frequency components of the lightning strike cannot be determined analytically, and difficulties arise when attempting to determine the produced electromagnetic fields [15]. This is due to there being no analytical integral to the function, or reliable method to determine its Fourier transform. However, the in-depth evaluation of a lightning strike's components and subsequent electromagnetic field generation is not required for this research. Hence, a trade-off is made between electromagnetic calculations and viability. This results in the choice of the Heidler function over the double-exponential lightning current model. This is given by (2), where  $I_0$  represents the amplitude of the channel base current,  $\tau_1$  and  $\tau_2$  represent the front and decay time constants respectively,  $\eta$  is the correction factor and  $n$  is the Heidler steepness factor (the influence of which is restricted to the high frequency range).

$$i(t) = \frac{I_0}{\eta} \left[ 1 - \frac{1}{1 + \left(\frac{t}{\tau_1}\right)^n} \right] e^{-\frac{t}{\tau_2}} u(t)$$

Where

$$\eta = e^{-\frac{\tau_1}{\tau_2} \left(n \frac{\tau_2}{\tau_1}\right)^{\frac{1}{n}}}$$

Lightning is a transient, high-current electric discharge. If a direct strike occurs on a line, the charge splits into two transient current waves, traveling in opposite directions to the point of contact. The surge impedance of the line links the transient overvoltage to the traveling current waves. This value is assumed to be 400 Ω. This value is based on literature research and can be determined using (3), which is based on a transmission tower model. Hence, the IEC overvoltage waveforms used to define equipment immunity to lightning currents can be represented as 10 000 kV/μs for 8/20 μs 10 kA peak current and 139 860 kV/μs for 10/350 μs 10 kA peak current. These values characterize the current waves from an indirect and direct lightning strike respectively and are employed in defining tests for SPDs according to IEC 61643-11. Furthermore, the impulse over-voltage that results from the strike is characterized by a 1.2/50 μs voltage waveform – which is employed in verifying the equipment's over-voltage withstand capability according to IEC 61000-4. Notably, in (3), the  $h_i$  variables represent the mast height from the bottom to midpoint and midpoint to tip. The  $r_i$  variables represent the radii at the bottom, top and midpoint (half of the sum of the top and bottom radii).

$$Z_{surge} = 60 \ln \left[ \cot \left( \frac{1}{2} \arctan \left( \frac{R_{avg}}{h_1 + h_2} \right) \right) \right] \quad (3)$$

Where

$$R_{avg} = \frac{r_1 h_1 + r_2 (h_1 + h_2) + r_3 h_1}{h_1 + h_2}$$

Footing resistance plays a considerable role in back-flashover protection performance. This is because a lower resistance implies a lower back-flashover rate. Lightning strikes to a mast or tower generate traveling voltage waves. These waves propagate along the structure, and are reflected at the foot and top of the tower. This effectively increases the voltage between the insulator and line, stressing it to the extent that it may flashover. This occurs if the transient over-voltage exceeds the withstand level of the insulator, leading to a phenomenon termed back-flashover. These back-flash voltages are developed by multiple reflections in the tower, as well as lines and adjacent towers. If the traveling voltage encounters a high footing impedance, it is likely to generate a higher magnitude reflected wave than for a smaller impedance value. This would effectively contribute to the prevalence of reflected voltages, intensifying the probability of back-flashover. One of the objectives of this paper is to establish good insulation coordination principles in the traction system. Hence, it is essential that the insulators do not flashover, which is accomplished by addressing the footing resistance of the mast.

The footing resistance of the mast is determined using transmission tower models. This is performed using (4) [17], where:  $R_f$  represents the footing resistance,  $R_0$  is the footing resistance at low current and frequency,  $E_0$  is the soil ionization gradient, and  $\rho$  is the soil resistivity. Typical towers have a footing resistance of 24 – 50 Ω, as observed in [18]. Literature further indicates that a higher tower footing resistance may lead to a higher trip-out rate [18]. A trip-out refers to the operation of a substation's circuit breaker, due to a lightning-induced flashover. Additionally, the trip-out rate is higher for towers with longer span lengths. This may be attributed to the increased likelihood of lightning strikes to the line with longer spans [19, 20]. Flashovers occur before the reflected wave from adjacent towers arrives, due to the steep potential increase in the tower. This indicates that a smaller structure should have a smaller footing resistance to achieve an acceptable flashover rate. The value obtained through multiple simulations (using a stroke current lower than the limiting current to initiate sufficient soil ionization) is around 16 Ω. This is considered acceptable for the above reasons. It is noted that the recommended soil ionization gradient value is 400 kV/m, the soil resistivity for the region is approximately 500 Ω m (obtained from measurements presented in [22]) and the low current

and low frequency footing resistance is estimated to be  $16 \Omega$  (a typical value according to [21]). Importantly, standards dictate that the footing resistance of a single mast should not exceed  $50 \Omega$ . This model is compliant with this value.

$$R_f(i) = \frac{R_0}{\sqrt{1 + \frac{2\pi R_0^2 i}{\rho E_0}}} \quad (4)$$

A surge in an equipment's earthing system is likely to initiate a potential rise in adjacent apparatus. This is problematic as it could damage equipment or result in human injuries. Unintentional increases in potential are often mitigated through the use of physical separation (minimum ground separation). However, there may be space limitations, whereby systems are in close proximity. This would result in difficulties in achieving earthing isolation by separation. Simulations of a radial earthing electrode are performed to determine a safe distance in which the earthing system of the overhead ground wire and surge arresters can be placed, to avoid influencing the mast's foundation grounding and the return rails. This is conducted through the use of FEMM, as presented in Figure 4. The surrounding soil is assumed to have a dielectric constant of 40 in the presence of a frequency impulse. This value is obtained from an average of soil types, presented in [22]. The earthing rod is subjected to a 100 kV impulse. This would be about double the expected peak lightning voltage. Testing with this value ensures that the system is robust enough to handle higher impulse magnitudes. It is observed that, even at a distance of 2.5 m from the electrode, the voltage is approximately 20 kV, which is likely to cause potential rises.

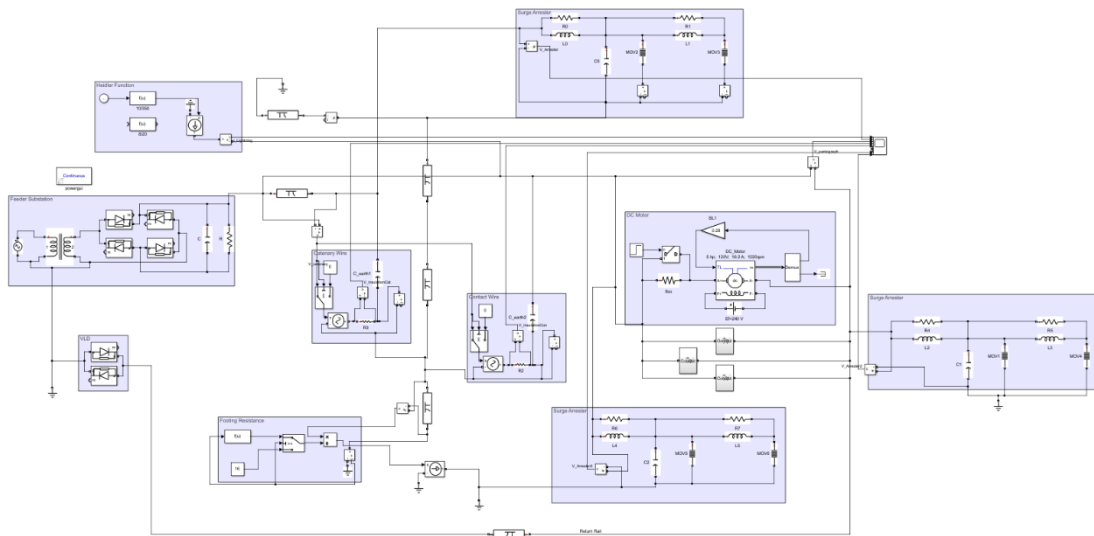
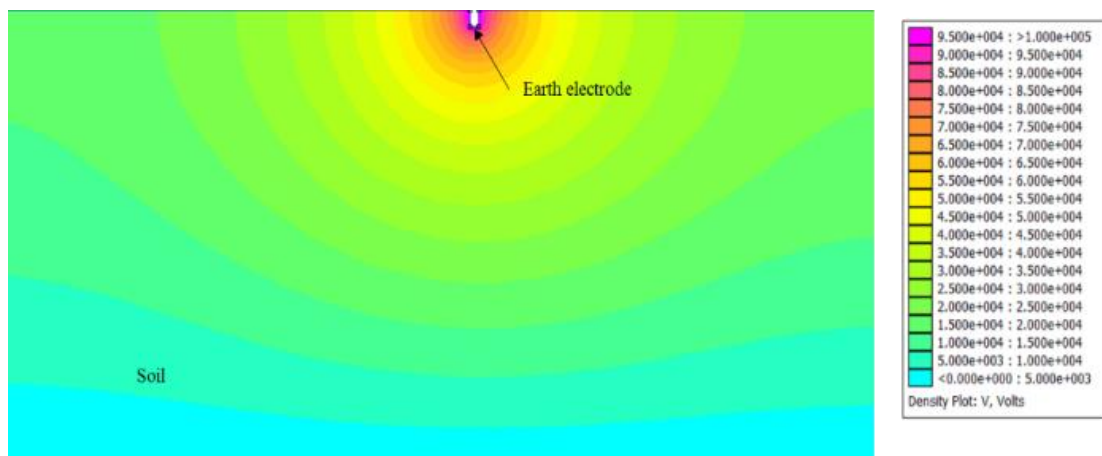

Figure 3. Circuit used to model overhead catenary system that has been outfitted with a LPS and the injection of a lightning impulse using the Heidler function (A larger version of the diagram can be provided on request)

Hence, the mast's foundation earthing would need to be unreasonably far from the overhead lines' ground to isolate the earths adequately. Research conducted in [23] indicates that a titanium oxide nano fluid barrier would reduce these values significantly. The reduction would be lower than the impulse withstand voltage of most equipment and not compromise animal and human safety. Based on the results presented in [23], a barrier with a width of 5 cm is likely to lower the potential and potential gradient at 2.5 m. This earthing isolation technique is employed for the overhead ground wire's grounding and that of the return rails.

The system is simulated in Simulink. This software is chosen as previous work in the HVDC transmission systems field has been conducted using this software. Furthermore, this software enables the definition of custom functions, which is required for the development of the Heidler function. The software has also high-performance capabilities, as error tolerances can be adjusted to obtain an accurate representation of the scenario. Since the lightning impulse is a rapid injection of transient over-currents to the system, it is required that the simulation tool used can sufficiently sample at a value which is small enough and within acceptable error tolerances to obtain an appropriate model and reliable results.

The fundamental dielectric properties of a piece of equipment are determined by the BIL. This is conveyed through apparatus testing using impulses with a peak value dictated by standards or regulations, typically a full-wave unidirectional voltage. The flashover (breakdown) voltage of system equipment must exceed the predetermined BIL of the equipment. Moreover, the sparkover and discharge voltages of protective devices must be less than the BIL value. This ensures that arresters discharge during a lightning surge application, and the equipment does not absorb the transient over-voltage. Furthermore, a margin between the arrester and equipment levels of insulation should be prominent.



(a)

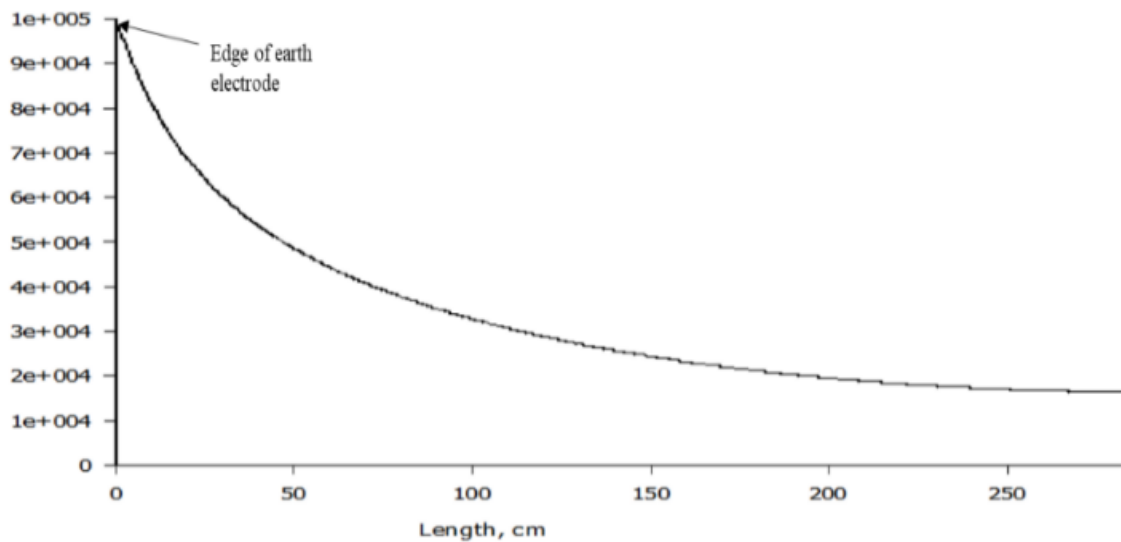

(b)

Figure 4. FEMM simulations of earthing electrode with the application of a 100 kV impulse in soil where (a) shows the voltage density plot and (b) shows the voltage decrease moving away from one edge of the electrode

Fundamentally, there should be no current flow through the insulators (between overhead feeder wires and mast). The simulation is performed by equating the BIL of these insulators to their breakdown voltage. This enables testing of the insulation coordination executed by the surge arresters. It is important that the



voltage protection level ( $U_p$ ) of the equipment is lower than the rated impulse withstand voltage ( $U_w$ ). Notably,  $U_p$  is the voltage across the surge arrester when it is conducting and is based on the chosen apparatus. Hence, this is the level at which the voltage across the protected load is clamped. Additionally,  $U_w$  is assigned by the manufacturer of the apparatus. The rated impulse withstand voltage is the power that can be applied to apparatus without flashing over or becoming damaged. This value is tested with a 1.2/50  $\mu$ s full-wave impulse and stated as the BIL of the equipment. The BIL of the system is said to be 143 kV.

Additionally, the system's normal operations should not be significantly hindered in the presence of a strike. This means that the voltage through the DC motors should be the same during a lightning strike as they are during normal operations. The current through the arresters and ground should be largely comprised of the lightning transient over-currents, and the DC motors and return rails should not have components of this current. The energy dissipated by the relevant MOAs should agree with the input to the circuit: in other words, there should be negligible voltage and current through the arrester during normal operations but significantly more during a lightning strike. The lightning energy absorbed by the arrester constitutes an important factor in determining the arrester's failure probability. If the energy absorbed by the arrester exceeds its withstand capability, it is damaged.

### 3. SYSTEM EVALUATION

It is essential that the system is analysed according to the success criteria discussed. Additionally, the response time of all arresters is evaluated, using the Heidler function impulse as a reference. For ease of documentation and referral, the various surge arresters are grouped according to their function. The MOA that protects the catenary and contact wires' insulators is referred to as  $A1_{feeder}$ , the MOA that protects the pantograph and electric locomotive is  $A1_{contact}$ . Additionally, the MOA that protects the return rail apparatus is  $A2_{return}$ .

The LPS is verified by comparing the performance of the system with and without the LPS designed. The lightning strikes are applied to the points discussed in the previous section. The success criteria are evaluated to determine if the insulators have been sufficiently protected, and the extent of protection provided by the MOAs and overhead ground wire. Additionally, protection of the pantograph and electric locomotive is investigated. The energy absorbed by the MOAs is measured and the level of protection they offer is addressed. This is done by considering their withstand capability.

Various lightning strikes are considered, with varying magnitude and durations. Compliance with IEC standards is observed (IEC 62305-4 is employed). To demonstrate the primary source of harm to the system, a 10/350  $\mu$ s impulse with peak values 200 kA, 150 kA and 100 kA is applied to the system [6]. This simulates the effect of a partial first positive stroke lightning current. Additionally, the withstand level of the equipment is evaluated using two lightning impulses, defined by 8/20  $\mu$ s and 1.2/50  $\mu$ s. The peak current values for these waveforms are 5 kA, 10 kA and 20 kA. It is noted that it is highly unlikely that the extremely high peak currents in the 10/350  $\mu$ s impulse category occur in KZN. Hence, smaller current peak values are also evaluated (the same as the other waveforms), which are common in the area.

There is no overhead ground wire in this case (as it is a constituent of the LPS). Hence, lightning strikes are applied to the contact and catenary wires, as well as the return rail. It is observed that the insulators of both the catenary and contact lines flash over during a lightning strike to either line. This is because the dropper wire acts as a connection between both lines, therefore conducting the transient over-voltage to the adjacent line. The insulators are modelled as a switch in parallel with a stray ground capacitance. Hence, if the switch is opened, there should be no voltage dropped across the capacitor. However, if there is a voltage dropped across the capacitor, it indicates that the voltage in the line surpassed the threshold of the switch. The potential across the capacitor indicates the voltage at which the insulator flashes over (which has the same magnitude as the transient overvoltage in these idealistic simulations). The energy dissipated by the insulators are also measured.

The energy dissipated by the insulators and return rail is extremely high during the 10/350  $\mu$ s impulse. This is due to the high peak values. This is likely to cause extreme heating of components and damage equipment. Although the energy dissipated by the other waveforms is significant, it may not lead to ignition of the immediate vicinity. Instead, however, there may be erosion of the insulating material and accelerated aging

of apparatus. These consequences can, similarly, be concluded from the transient over-voltages and currents. This is because energy is the time integral of the product of these values. Since the system cannot withstand the applied lightning impulses (the insulators flashover), it is concluded that there is no meaningful lightning protection without a dedicated LPS. Results are presented in Table I.

The voltage across insulators and the energy absorbed by the insulators are computed by equation (5) and (6) respectively.

$$V(t) = L \frac{di(t)}{dt} + Ri(t) \quad (5)$$

$$E = R \int i^2 dt \quad (6)$$

Where  $L$  and  $R$  are the inductance and resistance of the insulators respectively.

The longer the tail of the applied lightning impulse, the longer it takes for the energy to reach steady state. This is likely due to the slower decay, which means that a higher current value is recorded for a particular time instant than if the tail was shorter. This is similarly observed with the insulator voltage. The plateauing of the energy graph indicates there are no further increments of energy in the system. Hence, the energy already dissipated by the system is given by this levelled value.

Lightning impulses are applied to the contact wire, catenary wire, and the overhead ground wire. The latter of these cases present as a non-shielding failure event. Firstly, it is observed that the surge arresters are not activated during normal operations of the equipment. This is important, as the MOAs should not hamper the performance of the system when no lightning strike has occurred. Application of a lightning strike to the equipment is discussed according to the cases mentioned. The obtained results are summarized in Table II. The waveforms obtained in the simulation are not presented due to the space restrictions. Notably, the energies absorbed by the arresters only surpass their withstand capability in the presence of high peak currents (using a typical energy withstand capability of 45 kJ/kUp, where Up can be estimated as 4.5 kV).

A lightning flash to the catenary or contact wire could have two undesirable consequences, namely: flashover of the insulator and damage to the electric locomotive of the train via the pantograph. This could damage equipment by surpassing their insulation levels or dielectric strengths. Hence, the LPS is implemented to prevent the occurrence of these events. It is observed that insulators of both the catenary and contact wire do not flashover. This is indicated by the zero-voltage dropped across the stray ground capacitance, zero-current through the switch (modelling the insulator) and the resulting zero-energy dissipated. This substantiates that the AI feeder MOA has fulfilled its responsibility.

The other MOA implemented between this line and the tower's foundation grounding is AI contact. The purpose of this MOA is to prevent transient over-voltages from transmitting to the train electric locomotive. The voltage is clamped at the protection level of the MOA. This prevents damage to the traction system equipment. The potential clamping occurs before and after the lightning current peaks. This is because the over-voltage that accompanies the lightning increases with time, as with the over-current. Hence, the protection level may be surpassed by this potential as it rises, activating the arrester. Notably, the purpose of this arrester is to prevent the reception of a steep-gradient over-voltage at the pantograph that would result in the breakdown of insulation material. There are voltage oscillations observed in the pantograph, likely due to the length of the return rail intensifying the reflection phenomena (caused by coupling and mutual inductances). There is still an increase in voltage until the clamping occurs at the protection level. This is regarded as one of the system's shortcomings – a portion of the over-voltage is still communicated to the contact point between the pantograph and contact wire. Although a train may not be present at that exact moment of heightened potential, there is a small possibility it may be. This could damage internal equipment in the train. However, due to the short span of time in which this clamped over-voltage is present in the system, it is highly unlikely that an electric locomotive is in contact with the line during that time interval. Moreover, there are likely to be additional line-mast segments after the modelled one. This means that the over-voltage would be conveyed safely to ground in subsequent segments without damaging apparatus.

Simulations indicate that the device conducts over-current to the overhead ground wire. This conduction point is initiated when the over-voltage magnitude equates to the protection level of the arrester. At this point, the potential is clamped. It is observed that the catenary and contact insulators have no current flowing through them and there is no voltage across the stray ground capacitances. This indicates that the

insulators are not absorbing energy and have not flashed over. This indicates that the arrester intercepted the over-voltage that arose in both lines (since they are essentially paralleled). Furthermore, the voltage across the pantograph is clamped to an acceptable value with reasonable energy being absorbed.

It is observed that the A1feeder arrester is not activated (as it absorbs negligible energy) when the strike is closer to the pantograph. Furthermore, the A1contact arrester is not activated when the strike is closer to the junction between the catenary and contact wires, or directly to the catenary wire. This justifies the placement of two surge arresters. Both insulators are protected through the action of the feeder line's surge arrester. This is because the over-voltage on the contact line would have been transmitted to the catenary line, and vice versa. However, removal of either the A1feeder or A1contact arrester would result in difficulties protecting insulators and the pantograph simultaneously, depending on where the lightning strike terminates. Notably, the energy in the arresters reaches a maximum with a margin of time after the lightning impulse has reached its peak value. The relevant voltage measurements also exhibit clamping behaviour either before or after the lightning impulse reaches its peak current value, as this determines the over-voltage present in the system at a particular time.

For peak currents higher than 150 kA, the insulators are not sufficiently protected and they flashover. This is likely due to the high over-current generating a high over-voltage that overloads the MOA. This may also be attributed to reflection phenomena. Notably, this characteristic is tested using a 10/350  $\mu$ s waveform, as per IEC 62305-1 [4], indicating a lightning protection level (LPL) of III. When subjected to a 143 kV 1.2/50  $\mu$ s waveform, the BIL of the system can be evaluated. A 143 kV peak corresponds to a 35.8 kA peak current using a surge impedance of 400  $\Omega$ . The performance of the system is evaluated at 42 kA using a 1.2/50  $\mu$ s waveform and the insulators do not flashover, and the voltage in the line after the pantograph remains at acceptable levels even when this current is rounded up to 50 kA. This confirms the BIL of the system is maintained by the MOAs during lightning strikes that are common to the KZN region. The high energy absorbed by the arresters indicate that the vulnerable electrical components of the railway do not absorb this energy – essentially, the components are protected from the transient over-voltages imposed by a lightning strike. These over-voltages are clamped to an acceptable level based on the BIL (withstand capability) of the system. This is an energy phenomenon, as energy is the (time) integral of voltage and current.

A lightning flash to the return rails creates a large potential gradient between the electric locomotive and track. Additionally, this over-voltage can be conveyed to subsequent railway segments, which could cause stray currents and lead to electrochemical corrosion. The purpose of the A2return MOA is to protect the conduction of over-voltages to these subsequent segments. Hence, the over-currents from the strike are conducted to an isolated earthing system. The results obtained for this case are presented in Table II.

It is observed that the over-voltage that the rail is subjected to is clamped by the MOA. However, due to the length of the return rail (which can be hundreds of kilometres), reflection phenomena are prominent in this section of the system. Hence, there are oscillations about the protection level, with some fluctuations rising above the protection level (but remaining below the BIL of 143 kV). The percentage overshoot of this is 39.28%. This value can be reduced by decreasing the protection level of the arrester. This comes at the cost of potentially obtaining an unfeasible protection margin.

A strike to the overhead ground wire is conducted to the isolated earthing system. This is the most desirable case, as it avoids damaging internal equipment almost entirely. It is observed that the current in the overhead ground wire is very close to the peak current of the lightning impulse injected into the circuit.

The system is considered to have a LPL of III using the first positive impulse, as per IEC 62305-1 [4]. Importantly, further work must be conducted using the first negative impulse and subsequent negative impulse of lightning to confirm this and justify the system's sustainability, according to Annex B of IEC 62305-1 [4].

The MOAs require constant monitoring to observe their levels of degradation and aging. Additionally, if the overhead ground wire does not have adequate insulation, there may be adverse thermal effects in the presence of high over-currents. It is important that this system is maintained to avoid failure of subsequent apparatus struck by lightning. There is a potential for leakage currents from the MOAs, and hence this draws inappropriate amounts of power from the railway system. The effects of this can be mitigated by checking the behaviour of the components and rectifying the circuit appropriately (by cleaning the MOA or replacing it). However, the probability of a shielding failure is not immense. Importantly, the LPS facilitates enhanced

sustainability of the system it has been integrated into. Hence, the system has an adequate level of sustainability theoretically. But due to the deterministic and probabilistic nature of lightning impulses, it may not be fully acceptable to classify the system as sustainable until additional research is conducted more thoroughly.

#### 4. RECOMMENDATIONS FOR FURTHER IMPROVEMENTS

It is recommended that arcing horns are implemented across insulators. This ensures that over-currents can be conducted to earth via the mast. This acts as an additional precautionary measure but will come at increased costs. These devices have a lower breakdown voltage than the insulators they protect. Hence, the application of an over-voltage will cause it to breakdown, creating a diversion away from the insulator. This will reduce the risk of insulator damage in the event of shielding and arrester failure.

It is recommended that ongoing system maintenance is performed. There is a potential for structural aging owing to the interaction of space charge and the repetitive lightning application [24]. This is especially important to be considered in the railway operations of regions with high lightning density occurrence [25].

Table 1. Results obtained for energy absorption and potentials of different points in a traction system with the injection of lightning current wave forms and amplitudes in the absence of the designed LPS

Lightning Characteristics	Impulse	Lightning injection point				
		Either of the feeder lines			Return rail	
Waveform	Amplitude [kA]	Voltage across insulator line [kV]	Energy absorbed by both insulators [J]	Voltage across return rail [kV]	Energy absorbed by return rail [J]	
8/20 $\mu$ s	5	559	$1.12 \cdot 10^9$	551	$8.11 \cdot 10^4$	
	10	1 120	$7.35 \cdot 10^9$	1 101	$1.24 \cdot 10^5$	
	20	2 230	$8.55 \cdot 10^{10}$	2 203	$4.93 \cdot 10^5$	
1.2/50 $\mu$ s	5	1 750	$2.22 \cdot 10^9$	822	$8.10 \cdot 10^4$	
	10	3 500	$3.04 \cdot 10^{10}$	1 644	$3.24 \cdot 10^5$	
	20	7 100	$2.65 \cdot 10^{11}$	3 288	$1.29 \cdot 10^6$	
10/350 $\mu$ s	5	583	$9.95 \cdot 10^9$	683	$6.81 \cdot 10^4$	
	10	1 170	$7.45 \cdot 10^{10}$	1 367	$2.73 \cdot 10^5$	
	20	2 330	$8.95 \cdot 10^{10}$	2 735	$1.09 \cdot 10^6$	
	100	21 500	$6.04 \cdot 10^{12}$	13 670	$2.27 \cdot 10^7$	
	250	54 900	$2.47 \cdot 10^{13}$	34 150	$1.71 \cdot 10^8$	

Table 2. Results obtained for energy absorption and potentials of different points in a traction system with the injection of lightning current wave forms and amplitudes in the presence he designed LPS

Lightning Characteristics	Impulse	Lightning injection point					
		Close to the catenary wire		Close to the contact line or pantograph		Return rail	
Waveform	Amplitude [kA]	Voltage across A1 <sub>feeder</sub> [kV]	Energy absorbed by A1 <sub>feeder</sub> [J]	Voltage across A1 <sub>contact</sub> and line [kV]	Energy absorbed by A1 <sub>contact</sub> [J]	Voltage across A2 <sub>return</sub> [kV]	Energy absorbed by A2 <sub>return</sub> [J]
8/20 $\mu$ s	5	18	—	15	—	64	—
	10	36	—	31	—	67	$1.05 \cdot 10^4$
	20	65	—	62	—	77	$2.55 \cdot 10^4$
1.2/50 $\mu$ s	5	48	—	36	—	66	$1.54 \cdot 10^4$
	10	66	$2.02 \cdot 10^4$	66	$4.24 \cdot 10^3$	68	$3.74 \cdot 10^4$
	20	69	$8.52 \cdot 10^4$	73	$4.68 \cdot 10^4$	70	$8.06 \cdot 10^4$
10/350 $\mu$ s	5	68	$1.29 \cdot 10^5$	66	$6.95 \cdot 10^3$	48	$1.01 \cdot 10^5$
	10	70	$1.90 \cdot 10^5$	70	$6.52 \cdot 10^4$	73	$2.51 \cdot 10^5$
	20	72	$5.34 \cdot 10^5$	73	$2.38 \cdot 10^5$	73	$5.87 \cdot 10^5$
	100	74	$3.23 \cdot 10^6$	87	$2.43 \cdot 10^6$	80	$3.34 \cdot 10^6$
	250	84	$7.91 \cdot 10^6$	107	$7.56 \cdot 10^6$	81	$9.34 \cdot 10^6$

Space charge evolves in the system due to the DC electrode and becomes ionized by the insulation's impurities. This yields partial discharge events within the insulation or in close proximity to the conductor [26]. Ultimately, this contributes to accelerated material degradation and premature failure of the insulation [26-28]. Hence, the arrester housing should offer desirable pollution behaviour (hydrophobicity is advantageous) to reduce housing flash over events. Such issues are unique to DC systems and need not be addressed in analyzing similar studies related to AC power systems [29].

## 5. CONCLUSION

A lightning protection system has been designed that effectively reduces the transient over-voltages imposed on a 3 kV DC railway system to acceptable levels. The insulators of overhead lines are protected through the use of surge arresters, married with an overhead ground wire. An isolated earthing system is proposed to meet the energy and safety demands of the system. Additional metal oxide surge arresters protect the return rails of the traction scheme. The unification of these measures protects the railway against lightning strikes to overhead lines and return rails. An analysis of the performance of these components is conducted using Simulink. Measurements of relevant energies and voltages in the system are taken to perform this analysis. A BIL of 143 kV is retained through the use of this protective system. A discussion of lightning and its effects is presented. The typical constituents of a railway system are discussed, along with their functions. This substantiates the model generated and its behaviour. The protective system is considered to be LPL III. IEC standards are observed throughout the research process.

## ACKNOWLEDGEMENTS

We acknowledge the facilities rendered by the School of Electrical and Information Engineering, University of Witwatersrand and the ESKOM Power Plant Engineering Institute-Specialization Center, HVAC for making this work a success.

## REFERENCES

- [1]. M. Givoni, C. Brand And P. Watkiss, Are railways ‘climate friendly’?, *Built Environment*, 35(1), 70-86, 2009.
- [2]. J. H. Havenga, Z. P. Simpson, A. de Bod, South Africa’s freight rail reform: A demand-driven perspective, *Journal of Transport and Supply Chain Management*, 8(1), a153, 2014, 10.4102/jtscm.v8i1.153.
- [3]. J. Heyns and R. Luke, Rail commuter service quality in South Africa: results from a longitudinal study, 37th annual Southern African Transport Conference, Pretoria, South Africa, July, 2018
- [4]. IEC 62305-1: Protection against lightning - Part 1: General principles, 2010.
- [5]. C. Gomes and A. Gomes, Coordinated surge protection system in a TT wiring system: A comprehensive analysis of performance, XI SIPDA – International Symposium on Lightning Protection, Sao Paulo, Brazil, 2019, 10.1109/SIPDA47030.2019.8951659.
- [6]. International Electrotechnical Committee (IEC), Protection against lightning – Part 4: Electrical and electronic systems within structures, 2010.
- [7]. C. R. Evert and M. Gijben, Official South African Lightning Ground Flash Density Map 2006 to 2017, Earthing Africa Symposium, Johannesburg, 2017.
- [8]. M. Gijben, The lightning climatology of South Africa, *South African Journal of Science*, 2012.
- [9]. I. Wang, A. Cavallini and G. Montanari, The influence of repetitive square wave voltage parameters on enameled wire endurance, *IEEE Trans. Dielectr. Electr. Insul.*, p. 1276–1284, 2014. 10.1109/TDEI.2014.6832275.
- [10]. L. Frosini, Novel diagnostic techniques for rotating electrical machines—A review, *Energies* 13, 5066; 2020, 10.3390/en13195066.
- [11]. K. Nøland, M. Leandro, J. A. Suul, M. Molinas, High-power machines and starter-generator topologies for more electric aircraft: A technology outlook. *IEEE Access*, 8, 130104–130123. 2020, 10.1109/ACCESS.2020.3007791.
- [12]. M. Zielenkiewicz, T. Maksimowicz, R. Burak-Romanowski, Coordination of surge arresters in DC 3 kV railway traction system - field tests, 33rd International Conference on Lightning Protection (ICLP), 2016, 10.1109/ICLP.2016.7791506.
- [13]. M. Zielenkiewicz and T. Maksimowicz, Lightning protection zones created by traction construction of railways, International Conference on Electromagnetic Disturbances, Bialystok, Poland, 2015.
- [14]. P. Sestasombut and A. Ngaopitakkul, Evaluation of a direct lightning strike to the 24 kV distribution lines in Thailand, *Energies*, 12, 3193, 2019, 10.3390/en12163193.
- [15]. B. R. Terespolsky, An Approximation to the Heidler Function with an Analytical Integral for Engineering Applications Using Lightning Currents, Master Thesis, University of the Witwatersrand, Johannesburg, South Africa, 2015.
- [16]. V. Javor, New Functions for Representing IEC 62305 Standard and Other Typical Lightning Stroke Currents, *Journal of Lightning Research*, 50-59, 2012. 10.2174/1652803401204010050.
- [17]. P. Yadee and S. Premrudeepreechacharn, Analysis of Tower Footing Resistance Effected Back Flashover Across Insulator in a Transmission System, International Conference on Power Systems Transients (IPST’07), Lyon, France on June, 2007
- [18]. Y. Warmi and K. Michishita, Tower-Footing Resistance and Lightning Trip-outs of 150 kV Transmission Lines in West Sumatra in Indonesia, *MATEC Web of Conferences* 215, 01022, 2018, 10.1051/mateconf/201821501022.
- [19]. Rawi, Z. Kadir, C. Gomes and N. B. Azis, A case study on 500 kV line performance related to lightning in Malaysia, *IEEE Transactions on Power Delivery*, 99, December, 2017, 10.1109/TPWRD.2017.2787660.

- [20]. I. M. Rawi and M. Z. A. Ab. Kadir, Investigation on the 132kV overhead lines lightning- related flashovers in Malaysia, in Proc. VIII International Symposium on Lightning Protection (SIPDA), Balneario Comboriu, Brazil, 2015. 10.1109/SIPDA.2015.7339293.
- [21]. E. Singh, I. E. Davidson and G. K. Venayagamoorthy, Methodology for Measuring and Enhancing Tower Footing Resistance for Lightning Protection in an 88kV Line, SAUPEC, Durban, Kwa-Zulu Natal, 2017.
- [22]. D. Wobschall, A Theory of the Complex Dielectric Permittivity of Soil Containing Water: The Semidisperse Model, IEEE Transactions on Geoscience Electronics, 1977.
- [23]. C. Gomes and M. Izadi, Electrical Isolation of Two Earthing Systems under Lightning Conditions with TiCL Nano Fluid Barrier, in International Symposium on Lightning Protection (XV SIPDA), Sao Paulo, Brazil, 2019. 10.1109/SIPDA47030.2019.8951640.
- [24]. I. Färber, T. Guillod, F. Krismer, J. W. Kolar, and C. M. Franck, Endurance of Polymeric Insulation Foil Exposed to DC-Biased Medium-Frequency Rectangular Pulse Voltage Stress, *Energies*, 13(1), 13, 2020, 10.3390/en13010013.
- [25]. M. Z. A. Ab Kadir, N. R. Misbah, C. Gomes, J. Jasni, W. F. Wan Ahmad and M. K. Hassan, Recent statistics on lightning fatalities in Malaysia, International Conference on Lightning Protection (ICLP), 1-5, 2012. doi: 10.1109/ICLP.2012.6344337.
- [26]. X. Guo et al., Investigation of the Space Charge and DC Breakdown Behavior of XLPE/ $\alpha$ -Al<sub>2</sub>O<sub>3</sub> Nanocomposites, *Materials*, 13(6), 1333, 2020, 10.3390/ma13061333.
- [27]. J. Guo, Z. Zheng, A. Caprara, Partial Discharge Tests in DC Applications: A Review, IEEE Electrical Insulation Conference (EIC), Knoxville, TN, USA, 2020, 10.1109/EIC47619.2020.9158747.
- [28]. A. Gomes, E. Y. Lim, T. Islam, M.T. Parida, A.C.Y. Choo, A.H. Juliana, C. Gomes, M Z A Ab Kadir, and A. E. Gomes, Impulse flashover characteristics of oil palm trunk (OPT) veneer plywood, 34th International Conference on Lightning Protection (ICLP), Rzeszow, Poland, September, 2018. 10.1109/ICLP.2018.8503332.
- [29]. M. L. Tlhabanyane and C. Gomes, Response of a 25 kV AC railway traction system to lightning current transients and mitigation measures, SAUPEC- 2021, Potchefstroom, South Africa, January, 2021.