

## THE INFLUENCE OF PET AND PBT CONTAMINATION DURING TRANSPORTATION FUEL PRODUCTION VIA PYROLYSIS

*Zsolt Dobó, Tamara Mahner, Balázs Hegedüs, Gábor Nagy*

Department of Combustion Technology and Thermal Energy, Faculty of Materials Science and Engineering,  
University of Miskolc, Hungary,  
e-mail: zsolt.dobo@uni-miskolc.hu

*Received: February 9, 2021 • Accepted: March 1, 2021*

### ABSTRACT

The pyrolysis of plastic waste is a promising method to reduce waste accumulation while it could provide value-added transportation fuels. The main goal of this study is to investigate the influence of PET and PBT contamination during plastic pyrolysis oil production utilizing HDPE, LDPE, PP, and PS mixtures as these plastics are good candidates for transportation fuel production via pyrolysis and distillation. Seven different waste blends were prepared and pyrolyzed in a laboratory-scale batch reactor equipped with reflux. Mass balance, gas analysis, thermogravimetric analysis, and deposit formation were evaluated. It was concluded that by increasing the PET or PBT concentration in the initial solid waste mixtures, the oil production decreases while the amount of gases increases. Additionally, either PET or PBT generates operational difficulties due to they form deposits in piping system in form of benzoic acid. The maximum concentration of these plastic waste materials was 20% (PET) and 25% (PBT) in this study as further increase blocked the cross-section of piping, causing operational difficulties. Based on the obtained results the concentration of PET and PBT should be limited in waste mixtures when transportation fuel production is desired.

Keywords: Plastic waste, pyrolysis, reflux temperature

### 1. INTRODUCTION

Pyrolysis of plastic wastes is a promising method to reduce environmental waste accumulation and could provide value-added transportation fuels. Although the influencing factors of plastic waste pyrolysis were investigated by several researchers, such as temperature [1, 2], pressure [3], time [1, 4], type of reactor [5, 6], catalyst [7, 8, 9], or plastic waste material used [5, 10], there is still a need for deeper investigation of the pyrolysis process. The influence of different contaminations plays an important role in present researches as not all the plastic waste types are suitable for high quality pyrolysis oil production. HDPE, LDPE, PP, and PS provide excellent pyrolysis oils [11] while they are present in global waste streams more than 50%. PET also contributes a significant amount to plastic waste, but it does not provide pyrolysis oil suitable for transportation. Additionally, PET can easily cause operational difficulties during a pyrolysis process, which is unfavourable. One of the main products during PET pyrolysis is benzoic acid [12] forming solid products at ambient conditions. Thus, PET can easily form solid deposits in low-temperature piping systems while oil is not produced. Zero percent liquid product was also presented in the case of PET pyrolysis in another study [13]. PBT has a very similar molecular structure compared to PET, and thus it behaves similarly during a pyrolysis process; however, very limited information is available describing plastic mixtures containing PBT. It can be stated in both cases that the pyrolysis of these plastics is challenging, but, on the other side, they can be present in waste streams even when they are virtually separated. Additionally, it is expected that the behaviour of PET and PBT in a pyrolysis system might be similar, as minor differences could be seen in molecular structures.

The main goal of this paper is to investigate the influence of PET and PBT contamination on the pyrolysis process when HDPE, LDPE, PP, and PS mixtures are used as these four plastics could generate excellent fuels (through pyrolysis and distillation) with properties close to the traditional gasoline.

## 2. MATERIALS AND METHODS

The pyrolysis runs were performed in a laboratory-scale batch reactor equipped with reflux. The vapours exiting the reflux are condensed in a water-cooled heat exchanger, and the liquid product (pyrolysis oil) is collected in a product container at room temperature. The remaining gases were collected in a sample bag and flared after the measurements. Fig. 1 shows the schematic illustration of the measurement system.

The plastic waste recipes used in this study are summarized in Table 1. Each plastic waste blend contains five different plastic types separately gathered from local waste streams, and only the plastics with clearly visible identification codes were utilized. LDPE, HDPE, PP, and PS is present in each blend with a ratio representing the typical plastic demand in Hungary in 2018. 200 g solid waste blend was loaded into the reactor in each case, then the reactor was flushed with argon before measurement to eliminate the air from the system. The heat-up procedure started after the argon flush, and the pyrolysis runs were typically stopped when the temperature inside the reactor reached  $\approx 520$  °C as the cracking reactions ended by this temperature. It is worth noting that the PBT waste contained 15% glass fiber based on the identification code found on the surface of the material.

The pyrolysis gas was collected in a plastic sampling bag, and the composition was analyzed using gas chromatography (model: Dani Master; TCD detector with 3 columns: Restek RT-Q-Bond 30 m, 0.32 mm ID, 10  $\mu$ m, Restek RT-Q-Bond 15 m, 0.53 mm ID, 20  $\mu$ m and Restek RT-Msieve 5A 30 m, 0.53 mm ID, 50  $\mu$ m; FID detector with 1 column: Rt-Alumina BOND/Na<sub>2</sub>SO<sub>4</sub> 30 m, 0.53 mm ID, 10  $\mu$ m).

**Table 1. Plastic waste recipes utilized for PET and PBT contamination analysis**

Name	Concentration, %(m/m)					
	LDPE	HDPE	PP	PS	PET	PBT
PET-5	20.9	14.25	46.55	13.3	5	-
PET-10	19.8	13.5	44.1	12.6	10	-
PET-20	17.6	12	39.2	11.2	20	-
PBT-5	20.9	14.25	46.55	13.3	-	5
PBT-10	19.8	13.5	44.1	12.6	-	10
PBT-20	17.6	12	39.2	11.2	-	20
PBT-25	16.5	11.25	36.75	10.5	-	25

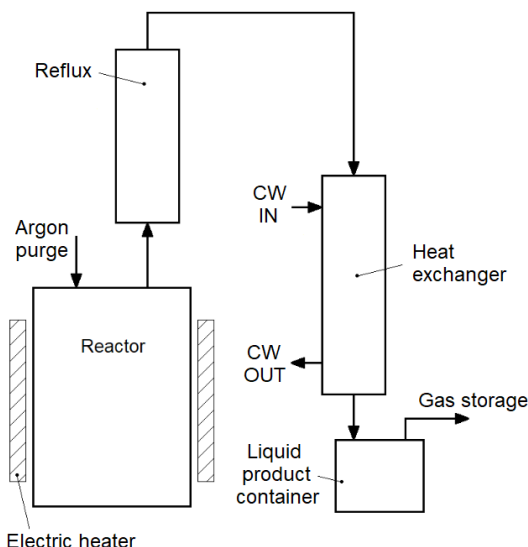

Figure 1. Schematic illustration of the measurement system

### 3. RESULTS

The mass distribution of the products during the pyrolysis runs is summarized in Table 2. Based on the obtained results, it can be stated that either PET or PBT significantly impacts the different products, which can be elucidated with the behaviour of pure materials during the pyrolysis runs. Based on a previous study [11], the neat PET generates 23.6% char and 76.2% gas, while less than 5% char and less than 40% gas might be generated in the cases of LDPE, HDPE, PP, and PS. This is supported by the TG analysis of materials used in this study (Fig. 2). It can be stated that high oil production can be reached when using LDPE, HDPE, PP, and PS plastic waste materials either in pure or mixed form. Thus, the addition of PET decreases the oil yield and increases the gas and char yield during the pyrolysis process. The same trends can be seen in the case of PBT contamination. It can be concluded that by increasing either PET or PBT in plastic wastes, the oil production decreases, while the gas and char production increases. This effect is not beneficial when oil production is the primary goal. Additionally, PET and PBT form benzoic acid, which is in the solid phase at ambient conditions. Thus, the benzoic acid can easily form deposits during pyrolysis runs with intensive cooling, such as during transportation fuel production via pyrolysis. The deposits were investigated in the system used in this study as well, Fig. 3 and Fig. 4 depict the actual status after each run. The thickness of the deposit increases by increasing the PET or PBT contamination; thus, a concentration limit was determined. Typically, the amount of solid deposit found in the heat exchanger after each run was slightly higher in the case of PBT. It was found that if the PET concentration is higher than 20%, then operational difficulties rise up while the oil quality significantly drops. The same in the case of PBT is 25%. Blending PET or PBT in higher concentrations is possible, but operational adjustments or system redesign is necessary, which can handle the above-mentioned deposit formation problems.

Table 2. Mass distribution of pyrolysis products utilizing various plastic waste mixtures

	PET-5	PET-10	PET-20	PBT-5	PBT-10	PBT-20	PBT-25
Oil, m/m%	77,6	70,55	63,3	76,85	73,6	63,75	59,8
Char, m/m%	6,6	7,15	7,55	4,3	5,45	7,55	10,5

Solid deposits in heat exchanger, m/m%	0,2	0,4	0,15	0,65	0,95	0,75	0,5
Gas*, m/m%	16,1	21,9	29	18,2	20	27,95	29,2

\*by difference

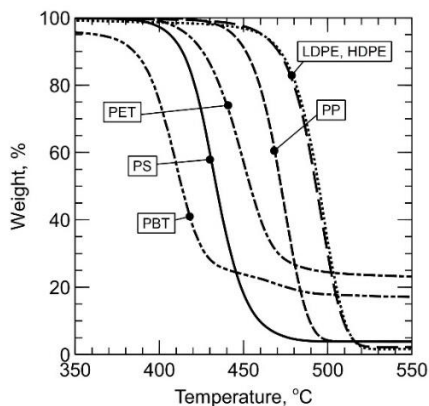

Figure 2. TG analysis of neat plastic wastes used in this study. MOM Derivatograph C/PC was used for measurements with a heating rate of 10 °C/min in a nitrogen atmosphere. The temperature is narrowed to a range of 350-550 °C for better illustration

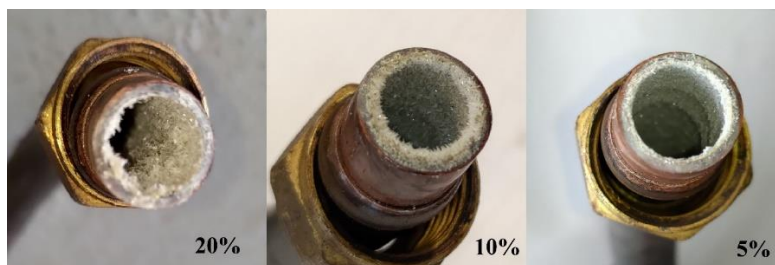

Figure 3. Deposit formation in case of PET

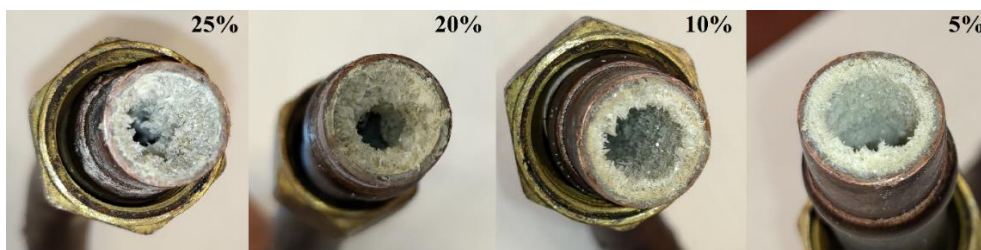

Figure 4. Deposit formation in case of PBT

The composition of the generated pyrolysis gas was measured by gas chromatography. The total hydrocarbon content of the gases is shown in Fig. 5. Generally, the hydrocarbon concentration decreases by increasing either the PET or PBT concentration of the initial solid blend, which can be elucidated with the fact that PET and PBT form mostly CO and CO<sub>2</sub> during a pyrolysis process due to the presence of oxygen atoms in the molecular structure. These oxygen atoms could partly or fully oxidize the carbon content. Additionally, PBT generates more hydrocarbons compared to PET as the presence of butylene in

PBT adds more hydrocarbons to the pyrolysis gas. The hydrocarbons are mainly C1-C4 group alkanes and alkenes. The concentration of CO and CO<sub>2</sub> among with two selected hydrocarbons (C<sub>2</sub>H<sub>6</sub> and C<sub>3</sub>H<sub>8</sub>) are depicted in Fig. 6. The CO and CO<sub>2</sub> increases, while the C<sub>2</sub>H<sub>6</sub> and C<sub>3</sub>H<sub>8</sub> decreases by increasing either the PET or PBT concentration. Generally, more CO and CO<sub>2</sub> were present in the gas phase during PET pyrolysis. As CO and CO<sub>2</sub> lower the heating value of the hydrocarbon-rich pyrolysis gas, PET and PBT contaminations are not beneficial in this context.

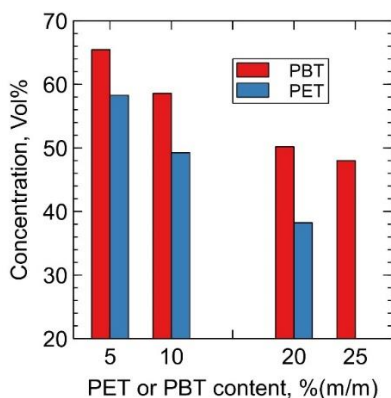

Figure 5. Total hydrocarbon content of the pyrolysis gas under various PET and PBT concentrations

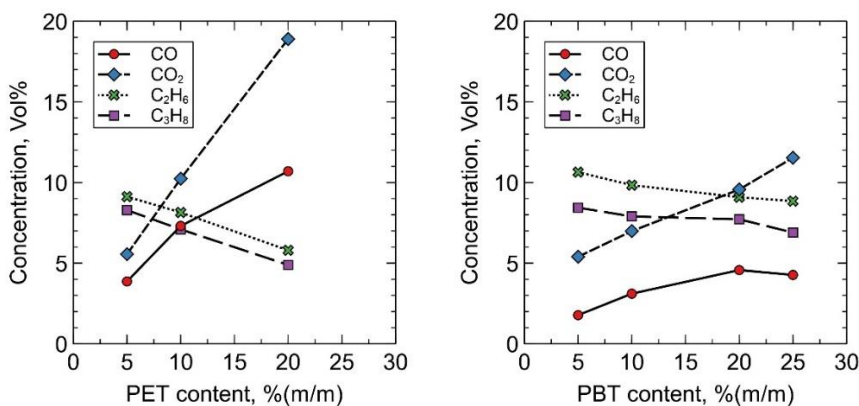

Figure 6. CO, CO<sub>2</sub>, C<sub>2</sub>H<sub>6</sub>, and C<sub>3</sub>H<sub>8</sub> content of the pyrolysis gas under various PET and PBT concentrations

## 4. CONCLUSIONS

The influence of PET and PBT contamination during the pyrolysis of HDPE, LDPE, PP, and PS plastic waste mixtures was investigated. Generally, the amount of pyrolysis oils decreased by increasing either PET or PBT in the initial solid material, while the amount of pyrolysis gases and solid residues increased. Additionally, the total hydrocarbon content decreased with PET/PBT increase, which is not beneficial from a heating value point of view. Solid deposits formed on the surfaces of heat exchanger piping and caused operational problems at higher concentrations; thus, the concentration of PET/PBT should be limited during the pyrolysis process. Overall, either PET or PBT is not beneficial when transportation fuel production is the primary goal of a pyrolysis process, and therefore pre-separation of these materials is necessary.

## 5. ACKNOWLEDGMENT

“The described article was carried out as part of the EFOP-3.6.1-16-2016-00011 “Younger and Renewing University – Innovative Knowledge City – institutional development of the University of Miskolc aiming at intelligent specialization” project implemented in the framework of the Szechenyi 2020 program. The realization of this project is supported by the European Union, co-financed by the European Social Fund.”

## REFERENCES

- [1] A. López, I. de Marco, B. M. Caballero, M. F. Laresgoiti, A. Adrados, Influence of time and temperature on pyrolysis of plastic wastes in a semi-batch reactor, *Chemical Engineering Journal*, 173 (1), pp. 62–71.
- [2] I. Kalargaris, G. Tian, S. Gu, The utilisation of oils produced from plastic waste at different pyrolysis temperatures in a DI diesel engine, *Energy*, 131 (2017), pp. 179–185.
- [3] K. Murata, K. Sato, Y. Sakata, Effect of pressure on thermal degradation of polyethylene, *Journal of Analytical and Applied Pyrolysis*, 71 (2) (2004), pp. 569–589.
- [4] L. S. Diaz Silvarrey, A. N. Phan, Kinetic study of municipal plastic waste, *International Journal of Hydrogen Energy*, 41 (37) (2016), pp. 16352–16364.
- [5] S. D. Anuar Sharuddin, F. Abnisa, W. M. A. Wan Daud, M. K. Aroua, A review on pyrolysis of plastic wastes, *Energy Conversion and Management*, 115 (2016), pp. 308–326.
- [6] E. Butler, G. Devlin, K. McDonnell, Waste polyolefins to liquid fuels via pyrolysis: Review of commercial state-of-the-art and recent laboratory research, *Waste and Biomass Valorization*, 2 (3) (2011), pp. 227–255.
- [7] R. Miandad, M. A. Barakat, A. S. Aburiazaiza, M. Rehan, A. S. Nizami, Catalytic pyrolysis of plastic waste: A review, *Process Safety and Environmental Protection*, 102 (2016), pp. 822–838.
- [8] R. Miandad, M. A. Barakat, M. Rehan, A. S. Aburiazaiza, I. M. I. Ismail, A. S. Nizami, Plastic waste to liquid oil through catalytic pyrolysis using natural and synthetic zeolite catalysts, *Waste Management*, 69 (2017), pp. 66–78.
- [9] A. G. Buekens, H. Huang, Catalytic plastics cracking for recovery of gasoline-range hydrocarbons from municipal plastic wastes, *Resources, Conservation and Recycling*, 23 (3) (1998), pp. 163–181.
- [10] B. Kunwar, H. N. Cheng, S. R. Chandrashekar, B. K. Sharma, Plastics to fuel: a review, *Renewable and Sustainable Energy Reviews*, 54. (2016) pp. 421–428.
- [11] Z. Dobó, Z. Jakab, G. Nagy, T. Koós, K. Szemmelveisz, G. Muránszky, Transportation fuel from plastic wastes: Production, purification and SI engine tests, *Energy*, 189 (2019), p. 116353.
- [12] S. D. Anuar Sharuddin, F. Abnisa, W. M. A. Wan Daud, M. K. Aroua, Energy recovery from pyrolysis of plastic waste: Study on non-recycled plastics (NRP) data as the real measure of plastic waste, *Energy Conversion and Management*, 148 (2017), pp. 925–934.
- [13] M. Sogancioglu, G. Ahmetli, E. Yel, A Comparative Study on Waste Plastics Pyrolysis Liquid Products Quantity and Energy Recovery Potential, *Energy Procedia*, 118 (2017), pp. 221–226.