

Efficient Reliability Analysis of Complex Systems in Consideration of Imprecision

Julian Salomon^{a,*}, Niklas Winnewisser^a, Pengfei Wei^{a,b,*}, Matteo Broggi^a, Michael Beer^{a,c,d}

^a*Institute for Risk and Reliability, Leibniz University Hannover, Hanover, Germany.*

^b*School of Mechanics, Civil Engineering and Architecture, Northwestern Polytechnical University, Xi'an, China.*

^c*Institute for Risk and Uncertainty, University of Liverpool, Liverpool, United Kingdom.*

^d*International Joint Research Center for Engineering Reliability and Stochastic Mechanics (ERSM), Tongji University, Shanghai, China.*

Abstract

In this work, the reliability of complex systems under consideration of imprecision is addressed. By joining two methods coming from different fields, namely, structural reliability and system reliability, a novel methodology is derived. The concepts of survival signature, fuzzy probability theory and the two versions of non-intrusive stochastic simulation (NISS) methods are adapted and merged, providing an efficient approach to quantify the reliability of complex systems taking into account the whole uncertainty spectrum. The new approach combines both of the advantageous characteristics of its two original components: 1. a significant reduction of the computational effort due to the separation property of the survival signature, i.e., once the system structure has been computed, any possible characterization of the probabilistic part can be tested with no need to recompute the structure and 2. a dramatically reduced sample size due to the adapted NISS methods, for which only a single stochastic simulation is required, avoiding the double loop simulations traditionally employed.

Beyond the merging of the theoretical aspects, the approach is employed to analyze a functional model of an axial compressor and an arbitrary complex system, providing accurate results and demonstrating efficiency and broad applicability.

Keywords: survival signature, system reliability, complex systems, reliability analysis, epistemic uncertainty, imprecision, fuzzy probabilities, extended Monte Carlo methods, non-intrusive imprecise stochastic simulation

1. Introduction

Engineering systems constitute a key factor for the state of development and progress of modern societies. Typical examples are infrastructure networks, industrial plants or machines, e.g., gas turbines. Closely integrated into society, the functionality of such complex capital goods has a significant impact on the economy as well as on everyday life. However, in reality, engineering systems deteriorate due to environmental and operational influences. As a result, their overall performance decreases over time or, in the worst case, they fail entirely. Consequently, for economic and safety-related reasons the reliability of a system, i.e., its continuous functionality, is of utmost importance. In order to ensure this reliability, appropriate decisions must be made in both design and maintenance. However, since societal growth and progress is accompanied by increasing size and complexity of societies' systems [1] and since "Global population growth will continue for decades, reaching around 9.2 billion in 2050 and peaking still higher later in the century," [2], this task, i.e., the identification of appropriate decisions towards maximum reliability, is

becoming increasingly challenging. For this reason, the development of sophisticated methods for quantifying and assessing system reliability gained more and more importance over the past decades [3, 4, 5, 6] and will receive even more attention in the future.

Conventional tools in system reliability assessment are failure mode and effect analyses, see, e.g., [7, 8], as well as more mathematical representations, such as reliability block diagrams, see, e.g., [9], fault tree and success tree methods, see, e.g., [10, 11]. However, as stated in [12], the calculations for identifying minimal path sets or cut sets might be too arduous for large complex systems, limiting the applicability of such methods. Further traditional approaches are Markov models, see, e.g., [13] and Petri nets, see, e.g., [14]. In recent research, system reliability assessment methods are provided, e.g., in [15] and [16] for multi-state systems, in [17], using Bayesian melding method, including various available sources on system, as well as subsystem level and in [18, 19], where Yang et al. as well as Xiao et al. propose approaches based on an active learning Kriging model, considering multiple failure modes and a multiple response model, respectively. Furthermore, Li et al. propose in [20] a reliability approach for analyzing systems composed of repairable components with complex failure distribution structure. A comprehensive review on

*Corresponding author

Email address: salomon@irz.uni-hannover.de (Julian Salomon)

numerous system reliability methods and the evolution of reliability optimization is provided in, e.g., [21, 22, 23].

Various system reliability approaches are based on the mathematical concept of the structure function that represents a functional state of a system in dependence on its components states, i.e., its state vectors, see, e.g., [24, 25]. Nevertheless, not only for large systems the structure function might become complicated or impractical [26, 27]. For coherent systems with components of only a single type, i.e., exchangeable components, the system signature represents a summarization of the structure function, providing an advantageous tool, see, e.g., [28].

In current research, the concept of survival signature is a promising approach to efficiently model the reliability of systems with multiple component types. The survival signature was introduced and discussed in [29, 30] as a generalization of the system signature. Apart from overcoming the restriction to systems with only one type of components, similar to the signature, the key feature of the survival signature is a clear separation between the structure of a system and the probabilistic properties of its components [31]. In addition, it summarizes the system structure by aggregating state vectors into single survival signature entries with associated reliabilities, resulting in significantly reduced storage requirements and simplified data access. Once the system structure has been evaluated – usually a demanding task – any number of calculations for various probability properties can be performed without having to recalculate it. Thus, compared to traditional approaches, the survival signature reduces the computational effort associated with repetitive model evaluations that are typically required in reliability engineering processes. A direct comparison between fault tree, Markov chain and survival signature modeling is presented in [32].

As stated in [12], a purely analytical implementation of the survival signature to real-life complex systems is often not feasible and simulations are required instead. Therefore, in [12], Patelli et al. provide simulation algorithms based on the concept of survival signature and Monte Carlo simulation (MCS). However, for large systems the computational effort of determining the survival signature might be prohibitive. Thus, current research addresses the approximation of survival signature entries by estimating the associated reliability values over a subset of corresponding state vectors, reducing computational expense for the single required topological system evaluation significantly [33]. Furthermore, in [34] an efficient algorithm for exact computation of system and survival signatures using binary decision diagrams is provided. In addition, sub-structuring the system in serial or parallel subsystems of smaller size and the subsequent merging of the survival signatures of these subsystems may be conducted [35]. Further research combines the notion of survival signature with multiple failure modes and dependent failures [36], common cause failures [37], interconnected networks [38] and multi-state components [12].

In reality, design and maintenance decisions determining

the reliability of a system have to be made under the presence of uncertain conditions. Gathering precise information is typically unfeasible, since, for instance, measurements of lifetime data and subjective assessments by experts are governed by uncertainty. Thus, comprehensive details, providing insight into the uncertain system behavior, are required. Consequently, a challenging task for engineers is how uncertainty can be integrated into reliability models. In the systemic context, current approaches to propagate uncertainty in the model are, e.g., Dempster-Shafer theory [39, 40], info-gap theory [41], p-boxes [42, 43] and fuzzy probabilities [44, 45]. It shall be noted that a lot of debate is present in the literature on various aspects of modeling uncertainties, such as the terminology and interpretation [46, 47] as well as their representation [48, 49]. In practice, the reduction of uncertainty is desired but associated with unavoidable costs, involving for example experimental campaigns, destructive testing, etc. Therefore, a trade-off is required by decision-makers, where a critical level of uncertainty needs to be identified among various design and maintenance measures in order to balance uncertainty and the costs associated with its reduction. This can be achieved by utilizing fuzzy probabilities as an appropriate uncertainty representation, as, e.g., Beer et al. propose in [50].

In the context of survival signature, several works, such as in [35, 51, 26, 12], have already demonstrated how the numerous advantages of the concept of survival signature and the consideration of uncertainties can be merged in an encompassing reliability analysis framework. Accounting for both aleatoric and epistemic uncertainties requires an adequate treatment in system analysis. An often conducted approach is a two-staged simulation, known as “double loop” approach, where variables with epistemic uncertainty are propagated in an “outer loop” and variables with aleatoric uncertainty are sampled in an “inner loop” [52], or, vice versa, aleatory variables are sampled in an “outer loop” and epistemic uncertainty is propagated in the “inner loop” [53]. It is obvious that for complex systems this naive approach leads to an extraordinarily large sample size and thus to high computational effort, see, e.g., [54]. Consequently, simulation methods that enhance computational efficiency and provide high accuracy with minimal sample size are desired.

Approaches to circumvent the exhaustive double loop simulation include interval MCS and interval importance sampling [55, 56], stochastic expansions and optimization-based interval estimation [57] as well as surrogate modeling via optimization and approximation techniques [58]. Latest methods to improve computational performance for uncertainty quantification, for instance, combine p-boxes, univariate dimension reduction method and optimization [59], utilize the augmented space integral [60] or apply line outage distribution factors [43]. Recently, Wei et al. introduced in [61] the non-intrusive stochastic simulation (NISS), a promising approach for efficient computation of imprecise structural models with a drastically reduced sam-

ple size. The method splits into two basic approaches, the local extended Monte Carlo simulation (LEMCS) and the global extended Monte Carlo simulation (GEMCS), coming along with different advantages in accuracy and variation.

In the present work, two methodologies from different fields, namely, structural reliability and system reliability, are joined to derive a novel and comprehensive approach for system reliability analysis taking into account imprecisions. More specifically, both, LEMCS and GEMCS, are adapted and merged with the concept of survival signature. Through the complex amalgamation, a new methodology is derived, combining the advantages of both original methods: a significant storage reduction of system topological information and major efficiency advantages in repeated model evaluations as well as an extensive consideration of uncertainties with just a single stochastic simulation needed, reducing the sample size dramatically. The combination of these advantages leads to beneficial synergy effects, increasing the efficiency even more. The representation of uncertainties is achieved by integrating fuzzy probabilities.

The paper proceeds as follows: Section 2 briefly reviews the fundamental theory of survival signature, uncertainty, fuzzy probability and NISS method. Based on this, Section 3 develops the proposed novel approach. In Section 4 the method is applied to a functional model of a multi-stage high-speed axial compressor as well as to an arbitrary complex system. Section 5 summarizes the results and discusses questions for future research.

2. Theoretical Fundamentals

2.1. Survival Signature

The survival signature according to [29] is a concept for efficiently determining the time-dependent reliability of systems that are composed of components of different types. Detailed information about the concept and its derivation can be found, e.g., in [29, 30, 51].

2.1.1. Structure Function

Suppose a system composed of m components of a single type. Then, $\mathbf{x} = (x_1, x_2, \dots, x_m) \in \{0, 1\}^m$ defines the state vector of these components with $x_i = 1$ indicating a functioning state of the i th component and $x_i = 0$ indicating a non-functioning state. The structure function ϕ is a function of the state vector, describing the operating state of the regarded system: $\phi = \phi(\mathbf{x}) : \{0, 1\}^m \rightarrow \{0, 1\}$. Accordingly, $\phi(\mathbf{x}) = 1$ indicates a functioning system and $\phi(\mathbf{x}) = 0$ indicates a non-functioning system with respect to the state vector \mathbf{x} .

Suppose a system composed of components of multiple types, i.e., $K \geq 2$, then the number of system components is given by $m = \sum_{k=1}^K m_k$ with m_k denoting the number of components of type $k \in \{1, 2, \dots, K\}$. Then, the state vector for each type can be defined, equivalent to systems with only a single component type, as $\mathbf{x}^k = (x_1^k, x_2^k, \dots, x_{m_k}^k)$.

2.1.2. Survival Signature and Survival Function

The survival signature describes the probability of a system being in a functioning state, purely depending on the number of functioning components l_k for each type k . Assuming the failure times of components of the same type to be independent, identically distributed (*iid*) or exchangeable within this type, the survival signature can be defined as:

$$\Phi(l_1, l_2, \dots, l_K) = \left[\prod_{k=1}^K \binom{m_k}{l_k}^{-1} \right] \times \sum_{\mathbf{x} \in S_{l_1, l_2, \dots, l_K}} \phi(\mathbf{x}), \quad (1)$$

with $\binom{m_k}{l_k}$ denoting the total number of state vectors \mathbf{x}^k of type k and S_{l_1, l_2, \dots, l_K} denoting the set of all state vectors of the entire system for which $l_k = \sum_{i=1}^{m_k} x_i^k$. Thus, the survival signature only depends on the topology of the system, regardless of any time-dependent failure behavior of its components. Note that the notion exchangeability, following [62], implies the input ordering of the random quantities being irrelevant. As a consequence in practice, rearranging the exchangeable assumed components should be irrelevant to real systems. For components that have the same functionality, come from the same manufacturer and operate in the same environment, the assumption of exchangeability is reasonable. However, as the environment changes, components of the same kind are exposed to different environmental stresses as, e.g., significantly different temperatures, affecting their behavior and further their lifetime probability distribution function. Here, assuming exchangeability would be inappropriate, see [12].

Let $C_k(t) \in \{0, 1, \dots, m_k\}$ denote the number of components of type k in a working state at time t and suppose the probability distribution for the failure times of type k to be known with $F_k(t)$, being the corresponding cumulative distribution function. Then

$$\begin{aligned} P \left(\bigcap_{k=1}^K \{C_k(t) = l_k\} \right) &= \prod_{k=1}^K P(C_k(t) = l_k) \\ &= \prod_{k=1}^K \binom{m_k}{l_k} [F_k(t)]^{m_k - l_k} [1 - F_k(t)]^{l_k} \end{aligned} \quad (2)$$

describes the probabilistic structure of the system, i.e., the time-dependent failure behavior of the system components, regardless of its topology. The survival function, describing the probability of a regarded system being in a functioning state at time t , results as:

$$\begin{aligned} P(T_s > t) &= \sum_{l_1=0}^{m_1} \dots \sum_{l_K=0}^{m_K} \Phi(l_1, l_2, \dots, l_K) \\ &\quad \times P \left(\bigcap_{k=1}^K \{C_k(t) = l_k\} \right), \end{aligned} \quad (3)$$

with T_s denoting the random system failure time. Thereby, the concept of survival signature separates the topology and the time-dependent probability structure. In addition, the survival signature is a summary of the structure function and, therefore, is advantageous compared to traditional methods when model simulations have to be conducted repeatedly, especially, if the system failure evaluation is computational expensive [12, 29]. Note that these are precisely the features that make the survival signature so unique and beneficial.

2.2. Uncertainty

In literature, various concepts concerning uncertainty are spread. Therefore, a brief clarification of the notion of uncertainty, its interpretation, classification and further a hint of how uncertainties can be advantageously implemented into the probability structure of a system, as presented in Section 2.1.2, is given in the following.

2.2.1. Interpretation of Uncertainty

Initially, a fundamental notion of uncertainty must be established. Following Nikolaidis in [63], uncertainty can be defined indirectly by the definition of certainty known from decision theory and its absence. This interpretation and its associated states are illustrated in Fig. 1(a). In this sense but extended to a more general interpretation, certainty, represented by state 4 in Fig. 1, is the state in which complete knowledge, e.g., concerning model input, is given. This state is ideal and a deterministic model can be utilized. Accordingly, uncertainty implies incomplete knowledge concerning, e.g., corresponding measures of a decision and their outcome as addressed in [63] or component behavior. Further, maximum uncertainty refers to complete ignorance, i.e., state 1, in which no knowledge is available at all. This is the worst case scenario yet appearing only in the theoretical sense. In practice, the present state of information, shown as state 2, typically includes both knowledge and uncertainty. The gap between complete ignorance and the present state of information relates to knowledge stated to be certain, i.e., it can be implemented in the model deterministically, while the gap between the present state and certainty corresponds to remaining uncertainty. Concerning decision-making, stakeholders intend, among other things, a maximum reduction of hazardous uncertainties, i.e., shifting the present state of information as close to certainty as cost and feasibility allow.

2.2.2. Classification of Uncertainty

In order to deal with uncertainties in analyses properly, e.g., Der Kiureghian & Ditlevsen propose a two-part classification of uncertainty in [47]: “The advantage of separating the uncertainties into aleatory and epistemic is that we thereby make clear which uncertainties can be reduced and which uncertainties are less prone to reduction, at least in the near-term, i.e., before major advances occur

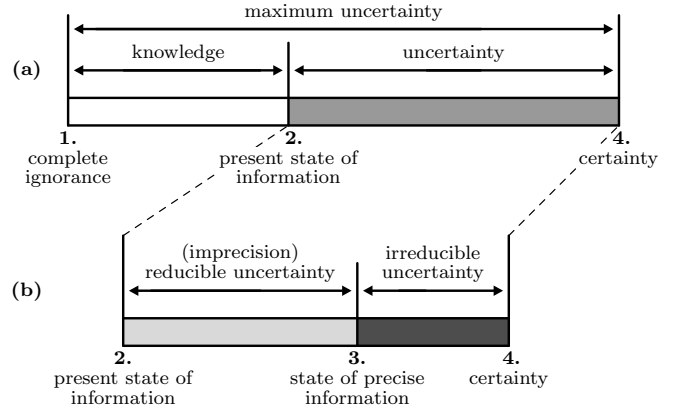

Figure 1: Interpretation of uncertainty; adapted from [63] and [46].

in scientific knowledge”. Nikolaidis remarks in [63] that further uncertainty taxonomies can be found in the literature. However, a broad consensus exists that in engineering practice a distinction between these two types of uncertainty is beneficial and sufficient [64, 46, 47]. Focusing on this two-part classification, for the first type frequently used terms are irreducible, aleatoric or objective uncertainty and the second is denoted as imprecision, epistemic uncertainty, reducible or subjective uncertainty. These terms are respectively utilized interchangeably among literature [65, 46]. However, the terminologies are up for debate as can be seen by comparing, e.g., [66, 46, 67]. Aughenbaugh & Paredis clarify in [46] the existence of aleatoric uncertainty as a controversial but philosophical issue and emphasize the terms irreducible uncertainty and imprecision with regard to practical application. Accordingly, these terms are used in the following.

Fig. 1 (b) illustrates the distinction into the above-mentioned two uncertainty types. Here, the state of precise information, shown as state 3, delimits irreducible uncertainty and imprecision. Thereby, the gap between state 3 and certainty denotes uncertainty that is claimed to be irreducible from the current perspective. This type arises from presumed variability and randomness and impedes the analyst from being certain throughout the evaluation process [64]. In contrast, the gap between the present state of information and state of precise information denotes imprecision. Imprecision arises, e.g., as only a limited amount of samples or subjective and, thus, fuzzy assessments of experts on component behavior are available. Further sources of imprecision and their consideration are discussed in [47] and [68]. Measures can be implemented to increase the quality of information and, therefore, reduce imprecision [64]. However, these are typically associated with effort and reaching the state of precise information may even be unfeasible.

2.2.3. Implementation of Uncertainty

Concepts to deal with uncertainty in a model can be distinguished into three groups, namely, non-probabilistic

approaches, precise probability approaches and imprecise probability approaches [61]. In order to propagate a clear distinction between irreducible uncertainty and imprecision throughout analysis only the latter appears appropriate [69, 61]. Thereby, set-theoretical concepts describing imprecision, such as intervals or fuzzy sets, and probability distributions from traditional probability theory that represent irreducible uncertainty are combined [46, 70]. Among various alternatives, in this context fuzzy sets are beneficial [71, 50]. For instance, Beer et al. utilize fuzzy sets in reliability analyses and propose two approaches to evaluate these. For more information see [72] as well as [50].

2.3. Fuzzy Probability

In system reliability engineering, imprecisions frequently occur, e.g., due to scarcity of data or vague expert knowledge regarding the underlying probability distribution types and distribution parameters of component lifetimes. Fuzzy probability theory enables to take these imprecisions into account.

Let $F(x)$ be a probability distribution function, describing the failure probability of a system component up to time x . Further, assume that the knowledge of the parameters of this distribution function is imprecise. Then Fig. 2 shows the fuzzy probability distribution function $\tilde{F}(x)$ describing this phenomenon, with $\mu(F(x))$ denoting the membership function of $F(x)$ and $\text{supp}(\tilde{F}(x)) = [\underline{F}^{\alpha_0}(x), \overline{F}^{\alpha_0}(x)]$ denoting the support of $\tilde{F}(x)$. Note that for $\mu(F(x)) = 1$, corresponding to an α -level of $\alpha = 1$, $\tilde{F}(x) = F(x)$.

In this work, all imprecise distribution parameters are modeled by triangular fuzzy numbers $\tilde{\theta} = (a/b/c)$, with $a < b < c$, $[a, c]$ denoting the base of $\tilde{\theta}$ and b denoting its vertex. In practice, the fuzzy probability model can be learned from (precise or censored) lifetime data by using either frequentist or Bayesian statistical inference methods. For example, given a small number of precise lifetime data, the $(100 \cdot \alpha)\%$ confidence intervals can be inferred for θ with either confidence interval estimation or bootstrap approach, where α can be taken as the membership level. Comprehensive information on fuzzy probability and its practical applications is provided, e.g., in [73, 74].

2.4. Non-Intrusive Imprecise Stochastic Simulation

The NISS, according to [61] and [75], provides a general methodological framework for propagating parameterized imprecise probability models through a black-box simulator with only one stochastic simulation. Indeed, any stochastic simulation algorithm can be injected into this framework to tackle different types of problems.

The original extended Monte Carlo simulation (EMCS) method was introduced in [76] for parametric global sensitivity analysis as well as parametric optimization and was further developed in [61] and [75] into the NISS framework for efficient evaluation of moments of imprecise response functions in a structural context. For the classical EMCS,

the unbiased estimators are derived by sampling from probability distribution functions of input variables with imprecise distribution parameters fixed at a particular point, hence, it has been referred to as LEMCS in further work. In [61], the GEMCS was established, where no fixed point of distribution parameter is required, but rather an auxiliary sampling distribution. Further, the combination of the LEMCS and GEMCS with high-dimensional model representation (HDMR) was presented in order to efficiently apply the NISS method to more sophisticated and high-dimensional models. Additionally, improvements for rare failure events were introduced to NISS in [75] and further developed in [77, 78].

Note that all NISS methods (including both LEMCS and GEMCS), although inspired by importance sampling, have significant different features, compared to the classical importance sampling including the one developed in [56]. The specific features of NISS can be summarized as follows: First, global NISS methods utilize samples generated from the joint space of component lifetimes and their imprecise parameters and show better global performance than the classical importance sampling, especially for the cases with large imprecision. Second, when applied to the cases with high-dimensional imprecise parameters, two types of HDMR decomposition are injected into LEMCS and GEMCS with proper truncation for substantial alleviating the expansion of variations of estimators, which is a common phenomenon appeared in all importance sampling based algorithms. Third, all classical stochastic simulation techniques for stochastic analysis, such as subset simulation and line sampling, developed for rare event analysis, can be injected into the NISS framework, following same rationale. This has substantially expended the suitability of NISS framework to different types of imprecise probability analysis tasks.

In this work, the LEMCS and GEMCS are reviewed, where LEMCS is the basis of all local NISS methods, while GEMCS provides a basis for all global NISS methods. The NISS methods are originally developed for performance and reliability estimation of structures simulated with a black-box model, such as a finite element model.

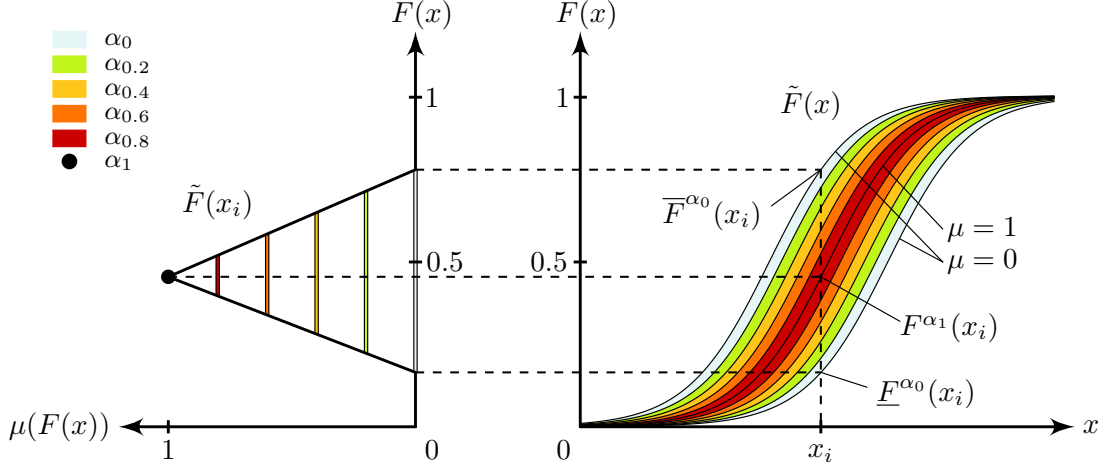

Figure 2: Fuzzy probability distribution function of a continuous fuzzy random variable; adapted from [73].

3. Proposed Methodology

In the following, the two basic NISS methods, LEMCS and GEMCS, are adapted and merged with the concept of survival signature allowing for efficient system reliability analyses under the constraint of imprecision. These two methods form the basis for all further developments included in the NISS framework.

Let $\mathbf{t} = (t_1, t_2, \dots, t_m)^\top$ denote the failure times of the components of a system and T_s indicates the failure time of the system. For a coherent system a non-decreasing deterministic function, denoted as $T_s = g(\mathbf{t})$, can be uniquely derived for modeling the relationship between system and component failure times. The failure times of all component functions are intrinsically random variables and the conditional joint density function is assumed to be $f(\mathbf{t}|\boldsymbol{\theta})$, where $\boldsymbol{\theta}$ indicates the q -dimensional vector of non-deterministic distribution parameters. The imprecision embodied through $\boldsymbol{\theta}$ might result from a lack of life data on components or expert knowledge and supports can be inferred by, e.g., confidence interval estimation. Based on the above setting, the system failure time is also a random variable with non-deterministic distribution parameters, where the probability distribution reflects the natural variability of system failure time and the bounds of probability reflect the degree of unknown on this variability. The system survival function can then be formulated as:

$$R_s(t, \mathbf{t}|\boldsymbol{\theta}) = \int_{\mathbb{R}^+} I[g(\mathbf{t}) > t] f(\mathbf{t}|\boldsymbol{\theta}) dt, \quad (4)$$

where \mathbb{R}^+ indicates the space of non-negative real numbers and $I[\cdot]$ is the indicator function with the values being either one if the argument is true or zero if it is false. With the above setting, the system survival function can be reformulated as:

$$R_s(t, \mathbf{t}|\boldsymbol{\theta}) = \int_{\mathbb{R}^+} I[g(\mathbf{t}) > t] \frac{f(\mathbf{t}|\boldsymbol{\theta})}{f(\mathbf{t}|\boldsymbol{\theta}^*)} f(\mathbf{t}|\boldsymbol{\theta}^*) dt, \quad (5)$$

where $\boldsymbol{\theta}^*$ can be any fixed and crisp point of $\boldsymbol{\theta}$. Then, given a set of random samples $\mathbf{t}^{(n)}$ ($n = 1, 2, \dots, N$) following $f(\mathbf{t}|\boldsymbol{\theta}^*)$, the LEMCS estimator of the system survival function is given as:

$$\hat{R}_s(t, \mathbf{t}|\boldsymbol{\theta}) = \frac{1}{N} \sum_{n=1}^N I[g(\mathbf{t}^{(n)}) > t] \frac{f(\mathbf{t}^{(n)}|\boldsymbol{\theta})}{f(\mathbf{t}^{(n)}|\boldsymbol{\theta}^*)}. \quad (6)$$

This estimator is unbiased and its variance can be easily derived. Given the above estimator, the bounds of the survival function can be computed by any global optimization algorithm, such as genetic and particle swarm algorithms.

The GEMCS method involves first attributing auxiliary distributions for $\boldsymbol{\theta}$, which, in the simplest case, can be uniform distributions within $[\boldsymbol{\theta}_{low}, \boldsymbol{\theta}_{up}]$. Let $p(\boldsymbol{\theta})$ denote the joint density function of these auxiliary distributions and $p(\theta_i)$ the marginal density function of θ_i . Then a set of joint random samples $(\mathbf{t}^{(n)}, \boldsymbol{\theta}^{(n)})$ can be generated following the joint density function $f(\mathbf{t}, \boldsymbol{\theta}) = f(\mathbf{t}|\boldsymbol{\theta}) p(\boldsymbol{\theta})$ of \mathbf{t} and $\boldsymbol{\theta}$, based on which the GEMCS estimator for the system survival function results as:

$$\hat{R}_s(t, \mathbf{t}|\boldsymbol{\theta}) = \frac{1}{N} \sum_{n=1}^N I[g(\mathbf{t}^{(n)}) > t] \frac{f(\mathbf{t}^{(n)}|\boldsymbol{\theta})}{f(\mathbf{t}^{(n)}|\boldsymbol{\theta}^{(n)})}. \quad (7)$$

Both the LEMCS and GEMCS performance might vary for different types of probability distributions or different distribution parameters and can depend on an appropriate choice for $\boldsymbol{\theta}^*$ and $p(\boldsymbol{\theta})$, respectively. More detailed information is provided in [61].

Another key feature of the classical NISS method is the HDMR, see [61, 75], based on which the behavior of the system survival function with respect to $\boldsymbol{\theta}$ can be learned visibly and the variation of estimators can be substantially reduced, especially when the number of components with imprecise distribution parameters is large. However, in

this paper, the LEMCS and GEMCS estimator are solely utilized without HDMR decomposition.

3.1. LEMCS Algorithm

A modified version of the MCS algorithm 2 in [12] is utilized as the stochastic simulation module for implementing LEMCS and GEMCS. The LEMCS algorithm is then described as follows:

- Step A1. Discretize the support $[0, \bar{t}]$ of system failure time uniformly as $0 = t_{z1} < t_{z2} < \dots < t_{zd} = \bar{t}$ and initialize the value of θ^* and the number N of deterministic simulations. Let $n = 1$.
- Step A2. Sample the failure times $\mathbf{t}^{(n)} = (t_1^{(n)}, t_2^{(n)}, \dots, t_m^{(n)})$ for all components following $f(\mathbf{t}|\theta^*)$ randomly.
- Step A3. At each time instant t_{zi} , count the number of components working for each component type as $C_k(t_{zi})$, where $k = 1, 2, \dots, K$ denotes the component type.
- Step A4. Evaluate the survival signature at each time instant as $\Phi_{zi}^{(n)} = \Phi(C_1(t_{zi}), C_2(t_{zi}), \dots, C_K(t_{zi}))$.
- Step A5. Define the weight function for the sample $\mathbf{t}^{(n)}$ as $w^{(n)}(\theta) = \frac{f(\mathbf{t}^{(n)}|\theta)}{f(\mathbf{t}^{(n)}|\theta^*)}$. If $n = N$, finish the simulation; else, let $n = n + 1$ and go back to Step A2.

Based on the samples $\Phi_{zi}^{(n)}$, the LEMCS estimator for the system survival function at time t_{zi} is formulated as:

$$\hat{R}_s(t_{zi}, \theta) = \frac{1}{N} \sum_{n=1}^N \Phi_{zi}^{(n)} w^{(n)}(\theta). \quad (8)$$

Computing at each time instant the minimum and maximum values of the estimator in Eq. 8, by utilizing any global optimization algorithm, leads to the estimated upper and lower bound of the system survival function.

3.2. GEMCS Algorithm

The GEMCS algorithm is similar to the LEMCS algorithm except that the stochastic simulation needs to be implemented in the joint space of \mathbf{t} and θ . Given the auxiliary density function $p(\theta)$, the GEMCS algorithm is described as follows:

- Step B1. Discretize the support $[0, \bar{t}]$ of system failure time uniformly as $0 = t_{z1} < t_{z2} < \dots < t_{zd} = \bar{t}$ and initialize the number N of deterministic simulations. Let $n = 1$.
- Step B2. Generate a joint random sample $(\mathbf{t}^{(n)}, \theta^{(n)})$ following the joint density $f(\mathbf{t}|\theta)p(\theta)$.
- Step B3. Same as Steps A3 and A4.
- Step B4. Evaluate the weight function for the joint sample $(\mathbf{t}^{(n)}, \theta^{(n)})$ as $w^{(n)}(\theta) = \frac{f(\mathbf{t}^{(n)}|\theta)}{f(\mathbf{t}^{(n)}|\theta^{(n)})}$. If $n = N$, finish the simulation; else, let $n = n + 1$ and go back to Step B2.

The GEMCS estimator for the system survival function is formulated equivalently to the LEMCS estimator in Eq. 8 and the estimated upper and lower bound of the system survival function can be computed at each time instant by utilizing any optimization algorithm. Note that the upper and lower distribution parameter vectors $\bar{\theta}(t_{zi})$ and $\underline{\theta}(t_{zi})$, corresponding to the maximum and minimum survival function values at time t_{zi} , are time-dependent and might vary for different time points.

One of the factors when performing the GEMCS method is the pre-specification of the auxiliary density $p(\theta)$. It has been demonstrated that the type of auxiliary distribution has minor effect on the performance of GEMCS estimators [79]. In this work, it is set as the uniform distribution within the support of θ .

The most appealing aspect of both the LEMCS and GEMCS algorithm is that only a single stochastic simulation is required in order to deal with the imprecisions. Therefore, the traditional utilized double loop simulation can be avoided. For both LEMCS and GEMCS, the interval analysis and stochastic analysis has been successfully decoupled and the computational cost is mainly governed by the one stochastic simulation performed. Furthermore, due to the merging with the survival signature, the stochastic analysis has been separated from the system topology, thus, only one reliability analysis with respect to the topology is required for generating the survival signature. Besides these advantageous properties of the survival signature, it is precisely the feature of only a single required stochastic simulation, that makes the proposed methodology so efficient and clearly distinguishes it from traditional approaches. Due to this approach, for any NISS method combined with the concept of survival signature, the imprecise stochastic analysis for estimating the bounds of system survival function has been simplified significantly.

3.3. Repeated p-box Analysis for Fuzzy Probability Approximation

In order to compute the survival function of a system with components whose random failure times are based on distribution functions with imprecise distribution parameters modeled by independent fuzzy numbers with support $[\mathbf{a}, \mathbf{c}]$, a procedure is needed to handle these in probabilistic models. In [50] such a procedure is provided, that is based on a repeated p-box analysis. The procedure is shown in Fig. 3. Each x^α denotes an α -level set of the fuzzy number \tilde{x} , representing an interval parameter of a probability distribution and, therefore, defining a p-box. This leads to an interval P_f^α associated with the same α -level. Repeating this p-box analysis with different α -levels leads to the fuzzy failure probability \tilde{P}_f . For more detailed information, see [50]. Note that the combined advantages of the proposed methodology, originating from the advantages of both the NISS methods and the concept of survival signature, as well as the beneficial synergy effects emerging from this combination, facilitate the nested p-box analysis with significantly reduced computational effort.

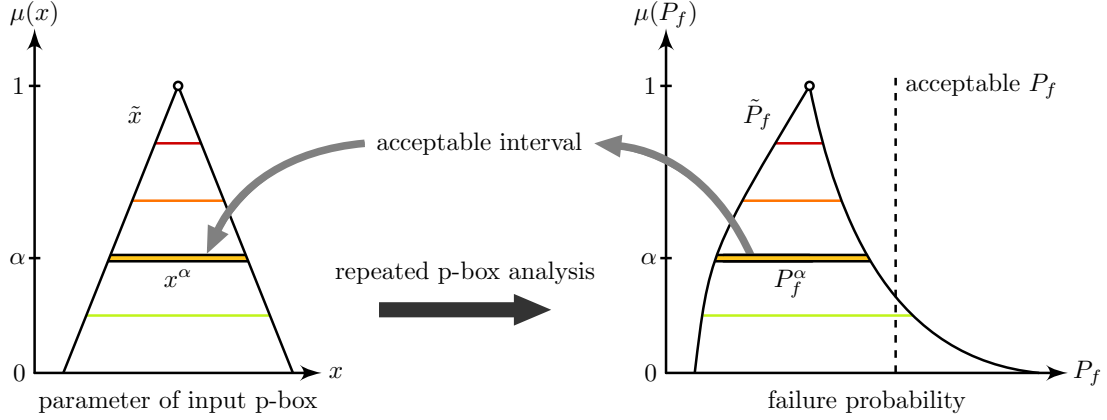

Figure 3: Nested p-box analysis to determine a fuzzy failure probability; adapted from [50].

3.4. Decision-Making Procedure

In reality, decision-makers typically encounter situations of imprecise knowledge about component behavior as starting point. This might be the case in design and maintenance, if, e.g., only insufficient information on the installed components has been collected so far. Depending on the budget, gathering precise information for each component type, e.g., via experimental campaigns, might not be feasible, impeding proper reliability analyses. In fact, a complete elimination of imprecision is in most cases neither necessary nor cost-efficient. Thus, a procedure for identifying a critical level of imprecision is crucial for cost-efficient decision-making, balancing the amount of imprecision and costs associated with its reduction. Integral parts of such a procedure are illustrated in Fig. 4.

To establish a basis for this procedure, the spectrum of imprecision can be represented by means of nested p-boxes, as proposed in Section 3.3. Further, a certain number of α -levels is determined. Note that a higher number of α -levels yields a more comprehensive imprecision analysis. In the simplest case, each upper and lower parameter bound is relatively changed to the same extent per α -level. Then, each $\theta^\alpha = (\theta_1^\alpha, \theta_2^\alpha, \dots, \theta_q^\alpha)$, with $\alpha \in [0, 1]$ and the number of distribution parameters q , is a tuple of parameter intervals θ_i^α of the fuzzy distribution parameters θ_i . Such an implementation allows the identification of a global critical imprecision level, as the imprecisions for each component type are altered simultaneously. A more detailed critical imprecision identification can be conducted by considering various mixed combinations of imprecision levels or, in a more sophisticated manner, e.g., by means of importance measures in a sensitivity analysis. However, this is beyond the scope of this paper. According to the simplest case, for each θ^α the imprecise model is evaluated, resulting in the lower survival functions $\hat{R}_s^\alpha(t_{zi}) = \hat{R}_s^\alpha(t_{zi}, \underline{\theta}^\alpha(t_{zi}))$ and upper survival functions $\bar{R}_s^\alpha(t_{zi}) = \bar{R}_s^\alpha(t_{zi}, \bar{\theta}^\alpha(t_{zi}))$ at each time step t_{zi} . Correspondingly, the time-dependent upper and lower distribution parameter vectors are $\bar{\theta}^\alpha(t_{zi}) \in \mathcal{I} = \{(\theta_1, \theta_2, \dots, \theta_q) | \theta_i \in \theta_i^\alpha \forall i =$

$1, 2, \dots, q\}$ and $\underline{\theta}^\alpha(t_{zi}) \in \mathcal{I}$. Further, a set of reliability requirements $\mathcal{R} = \{(t_1, R_1), (t_2, R_2), \dots, (t_r, R_r)\}$ is established, where the tuple (t_j, R_j) , with $j = 1, 2, \dots, r$, specifies a pair of time and reliability values for r requirements. Typically, in practice, only $\hat{R}_s^\alpha(t_{zi})$ is relevant with respect to \mathcal{R} . Then, $\hat{R}_s^{cr}(t_{zi}) = \min_\alpha \{\hat{R}_s^\alpha(t_{zi}) | \hat{R}_s^\alpha(t_j) \geq R_j, (t_j, R_j) \in \mathcal{R} \forall j = 1, 2, \dots, r\}$ is the critical, i.e., last acceptable, lower survival function. Thereby, $\alpha_{cr} = \arg \min_\alpha \{\hat{R}_s^\alpha(t) | \hat{R}_s^\alpha(t_j) \geq R_j, (t_j, R_j) \in \mathcal{R} \forall j = 1, 2, \dots, r\} \in [0, 1]$ indicates the critical α -level. Note that lower distribution bounds not necessarily yield lower response function bounds and vice versa. In accordance, $\theta_{cr} = [\underline{\theta}^{\alpha_{cr}}, \bar{\theta}^{\alpha_{cr}}]$ is the interval of acceptable imprecision. As a consequence, imprecision has to be reduced at least up to the bounds of θ^{cr} . This reduction can be achieved for instance by investing more budget in experimental campaigns, destructive testing, etc.

The procedure allows decision-makers the straightforward and reliable identification of acceptable levels of imprecision in the underlying failure probabilities, e.g., in the design of new systems. Corresponding to the requirements defined in the right graph of Fig. 4, the acceptable α -level is $\alpha_{cr} = 0.7$ with the tuple of parameter intervals $\theta_{cr} = (\theta_1^{0.7}, \theta_2^{0.7}, \theta_3^{0.7})$ contained in the tuple of fuzzy numbers $\bar{\theta} = (\theta_1, \theta_2, \theta_3)$. This decision-making procedure is demonstrated for the case study in Section 5.3.

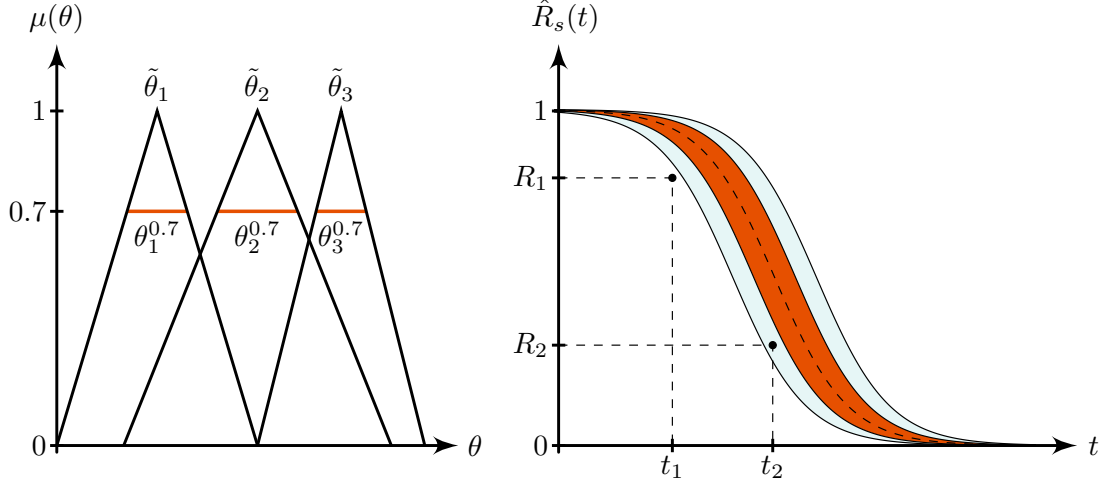

Figure 4: Decision-making procedure.

4. Multi-Stage High-Speed Axial Compressor

Axial compressors are complex multi-component machines that are employed in major sectors of society, e.g., in the industrial sector, as a key component of gas turbines for electricity production or as part of aircraft engines in the public transport or military sector. Therefore, in both design and maintenance, it is critical to consider as many system performance influencing, certain and uncertain, information as possible to maximize the reliability of the compressor efficiently. In order to illustrate this, the proposed method is applied to a functional model of an axial compressor.

4.1. Model

In [80] a functional model of an axial compressor is developed as the foundation for a reliability analysis. This model has been created to represent the reliability characteristic and functionality of the four-stage high-speed axial compressor of the Institute for Turbomachinery and Fluid Dynamics at Leibniz Universität Hannover. Detailed information about this axial compressor is provided in [81].

The functional model captures the dependence of the overall compressor performance, namely, the total-to-total pressure ratio and the total-to-total isentropic efficiency, on the surface roughness of the individual blades, arranged in rotor and stator rows. It is based on the results of a sensitivity analysis of an aerodynamic model of the compressor. A network representation of the functional model is shown in Fig. 5. Each component represents either a stator (S1 — S4) or rotor row (R1 — R4).

The rows are classified into four component types. This classification as well as the component arrangement is chosen based on the effect of their blade roughness on the two performance parameters of the axial compressor. More specifically, a connection between start and end implies a functioning state of the compressor and an interruption of this connection means exceeding a roughness-related

performance variation of at least 25%, corresponding to a non-functioning state. More detailed information on the functional model and its formulation can be obtained from [80].

4.2. Reliability Analysis

For the time-dependent reliability analysis, each row, i.e., each component of the functional model, is characterized by a failure probability depending on its component type. Note that the model is thus formally a reliability block diagram (RBD) [9]. In practice, the underlying distribution functions have to be derived from existing operational data. However, in order to prove the usability of the proposed method and the capability of dealing with imprecisions, exponential functions with imprecise parameters are assumed for all components. The imprecise parameters are modeled by triangular fuzzy numbers. Depending on the respective component type, the following parameters are assumed: $\lambda_1 = (0.1/0.15/0.2)$ for type 1; $\lambda_2 = (0.2/0.25/0.3)$ for type 2; $\lambda_3 = (0.4/0.5/0.6)$ for type 3; $\lambda_4 = (0.6/0.7/0.8)$ for type 4.

After determining the survival signature of the compressor, in a first step, the imprecise parameters are taken into account by approximating them with a single p-box, being the base of each triangle fuzzy parameter, corresponding to an α -level of $\alpha = 0$. The imprecise parameters result as: $\lambda_1 \in [0.1, 0.2]$ for type 1; $\lambda_2 \in [0.2, 0.3]$ for type 2; $\lambda_3 \in [0.4, 0.6]$ for type 3; $\lambda_4 \in [0.6, 0.8]$ for type 4. Based on the functional compressor representation, shown in Fig. 5, the upper and lower bounds of the survival function of the compressor are obtained and displayed in Fig. 6: 1. via traditional double loop approach; 2. via LEMCS algorithm with $\lambda_1^* = 0.1$, $\lambda_2^* = 0.2$, $\lambda_3^* = 0.4$, $\lambda_4^* = 0.6$ as the best fits for λ_i^* ; 3. via GEMCS algorithm with $p(\boldsymbol{\lambda})$ assumed to be uniform; 4. analytically. Note that the sampling density for LEMCS estimation is generated by setting λ_i^* at their lower bounds. For exponential distribution, only with this setting, the support of the sampling density will coincide

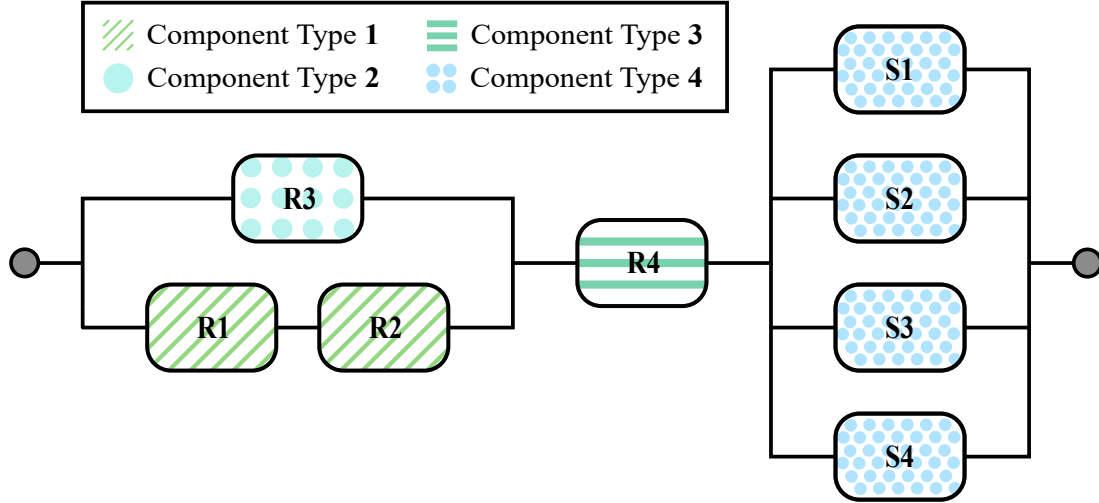

Figure 5: Functional model of the multi-stage high-speed axial compressor.

with the support of the imprecise probability models when their distribution parameters vary in their imprecise intervals. This principle for specifying the sampling density is referred to in [61]. The double loop approach is conducted with 5 000 samples (failure times) on the inner loop and 1 000 samples (λ -values) on the outer loop. In other words: 1 000 λ -vectors are sampled (epistemic space), representing 1 000 different probabilistic models. Each model is solved by MCS algorithm 2 in [12], generating 5 000 failure time vectors per model, i.e., a total of 5 000 000 samples. Then the enveloping system reliability is determined by identifying the minimum and maximum survival function value for each time step. Note that the number of samples for the double loop approach, i.e., the number of failure times as well as the number of samples in epistemic space, is adopted from [12]. For both LEMCS and GEMCS where only one simulation is required, 100 000 samples (failure times) are generated each, i.e., only 1/50th of the sample size compared to the double loop approach. Time discretization is set to $\Delta t = 0.05$. Furthermore, the precise survival function of the axial compressor model, i.e., with distribution parameters $\lambda_i = b_i$, is determined and displayed in Fig. 6 as well.

Clearly, both the LEMCS and GEMCS algorithm approximate the analytically calculated upper and lower bound of the survival function accurately with relative errors of: $\bar{\delta}_{LEMCS} = 0.23\%$, $\underline{\delta}_{LEMCS} = 0.23\%$ and $\bar{\delta}_{GEMCS} = 0.29\%$, $\underline{\delta}_{GEMCS} = 0.3\%$, where $\bar{\delta}$ relates to the upper and $\underline{\delta}$ to the lower bound of the survival function. Despite a 50-times increased sample size, the double loop approach performs significantly worse and does not capture the outer boundaries of the survival function correctly, see Fig. 6. Correspondingly, the relative errors are larger with: $\bar{\delta}_{DoubleLoop} = 0.98\%$ and $\underline{\delta}_{DoubleLoop} = 2.58\%$. To achieve the same quality of results with the double loop approach as with the LEMCS or GEMCS, significantly more samples than the 5 000 000 would be required.

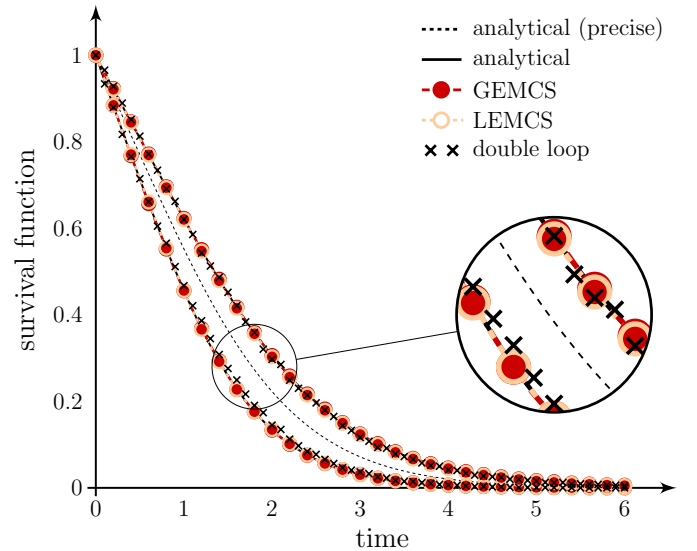

Figure 6: Survival function bounds of the functional compressor model via double loop approach, LEMCS algorithm, GEMCS algorithm and analytically.

It shall be noted, that, in general, the GEMCS algorithm has better global performance than the LEMCS algorithm, as demonstrated and discussed in the following, second case study. Further, the approximation quality of the LEMCS algorithm highly depends on the choice, respectively, on the knowledge of the preselected distribution parameters λ_i^* .

In a second step, by performing a nested p-box analysis to determine fuzzy failure probabilities, described in Section 3.3, further bounds of the survival function for different imprecision levels can now be determined, based on various α -levels. With regard to the survival signature, these only represent a change in the probability structure. Due to the separation between topological and probability structure, the survival signature does not have to be recal-

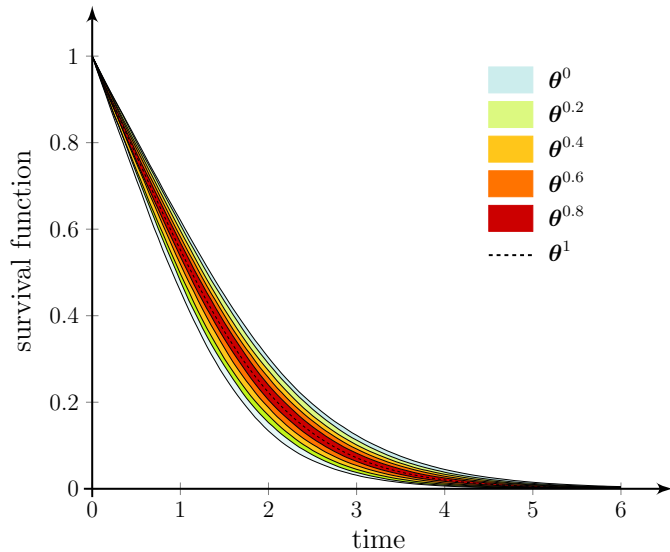

Figure 7: Survival function bounds of a functional compressor model via LEMCS algorithm with fuzzy probability approximation.

culated, neither for parameter variations within an α -level, nor for each new α -level, only the probability structure has to be adapted. This results in a substantial reduction of the computational effort.

The results of the LEMCS algorithm for different α -levels are shown in Fig. 7. Note that for each α -level just one single stochastic simulation, according to Section 3.1, has to be performed. Clearly, these results support decision-makers in design and maintenance processes of complex capital goods to estimate the level of imprecision that is bearable and still ensures acceptable reliability.

5. Complex System

In [12] the authors test their introduced simulation approaches for reliability analysis on an arbitrary complex system. In order to demonstrate the broad applicability as well as efficiency of the method proposed in this work, the complex system from [12] is considered and a reliability analysis is conducted, taking into account imprecisions.

5.1. Model

The complex system consists of 14 components each of which is assigned to one of six component types. Figure 8 illustrates the complex system and the assignment of components to their types. A connection between the start and destination node indicates a functioning and an interruption of this connection a non-functioning state of the system.

5.2. Reliability Analysis

Each system component is characterized by a specific time-dependent failure behavior depending on its assigned component type. Again, in practice, the underlying distribution functions, describing this behavior, need to be

derived from existing operational data. However, for the purpose of proof of concept and applicability, the arbitrary distributions and corresponding imprecise parameters shown in Tab. 1 are assumed. Note that thus the complex system is formally an RBD. As for the reliability analysis in the previous section, the imprecise distribution parameters are modeled by triangular fuzzy numbers.

The survival signature of the complex system is provided in Tab. 2 and Tab. 3. For the sake of conciseness, only the non-trivial survival signature values are shown, i.e., all values that are not equal to zero or one.

For the time-dependent reliability analysis, the imprecise distribution parameters are first assumed to be precise by considering just the vertex b of each triangular fuzzy number. Second, the analysis is conducted by approximating the distribution parameters with a single p-box, corresponding to the base boundaries a and c of the fuzzy numbers. Third, the full imprecision is addressed in Section 5.3 by considering the fuzzy numbers according to the repeated p-box analysis described in Section 3.3.

In Fig. 9 the resulting survival function bounds of the complex system are displayed: 1. via traditional double loop approach; 2. via LEMCS algorithm with θ_i^* corresponding to the upper base bounds c_i of each fuzzy parameter for all two-parametric distributions and with θ_i^* corresponding to the lower base bounds a_i for both exponential distributions, see Tab. 1; 3. via GEMCS algorithm with $p(\theta)$ assumed to be uniform; 4. analytically. Again, the double loop approach is conducted with 5000 samples (failure times) on the inner loop and 1000 samples (θ -values) on the outer loop. As in the previous case study, the number of samples for the double loop approach is adopted from [12]. For the one required LEMCS and GEMCS simulation, 200 000 samples (failure times) are generated each, i.e., only 1/25th of the sample size compared to the double loop approach. Time discretization is again set to $\Delta t = 0.05$. In addition, the precise survival function of the complex system, i.e., with distribution parameters $\theta_i = b_i$, is determined and displayed in Fig. 9.

As in the previous analysis of the axial compressor, both the LEMCS and GEMCS algorithm approximate the analytically determined bounds of the survival function of the complex system with high accuracy, see Fig. 9. However, considering the relative errors of both algorithms, it is noticeable that the GEMCS approximates both bounds equally well, with errors of $\bar{\delta}_{GEMCS} = 0.15\%$ and $\underline{\delta}_{GEMCS} = 0.12\%$, whereas the LEMCS algorithm provides a deviation in the quality of the bound approximation that is more significant with $\bar{\delta}_{LEMCS} = 0.06\%$ and $\underline{\delta}_{LEMCS} = 0.32\%$. The different bound qualities provided by the LEMCS are due to its locality property that is determined by the choice of the preselected θ^* . The LEMCS performs locally, i.e., in the region of θ^* excellent but worse on a global scale. However, since with the GEMCS all failure times are sampled uniformly over the entire range of θ , it has better global performance, as shown by these results. It shall be noted that in case

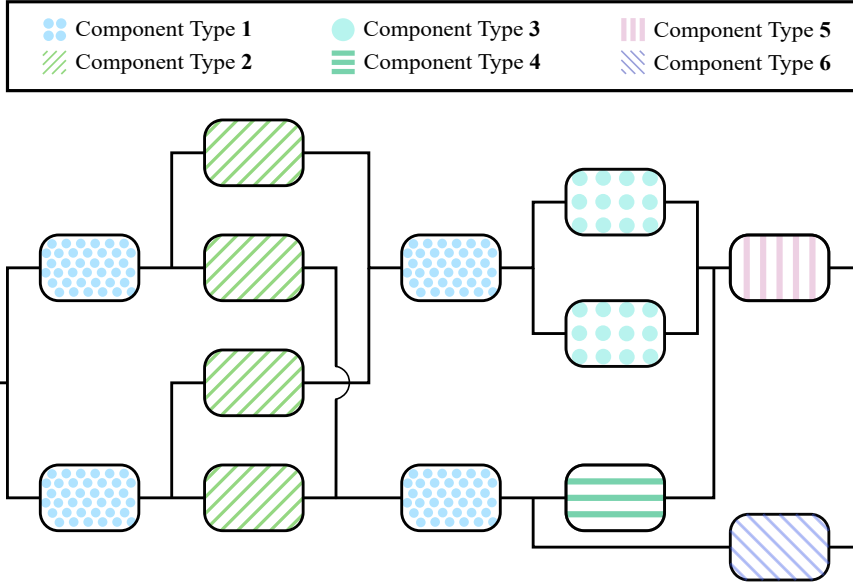

Figure 8: Representation of the arbitrary complex system with 14 components, adapted from [12].

Table 1: Distribution functions and parameters for each component type of the complex system.

Component type	Distribution	Parameters	Triangular fuzzy numbers
1	Weibull	[scale, shape]	[(3.6/4.0/4.4), (2.1/2.25/2.4)]
2	Exponential	[λ]	[(0.1/0.15/0.2)]
3	Weibull	[scale, shape]	[(2.9/3.05/3.2), (0.8/0.95/1.1)]
4	Log-normal	[μ, σ]	[(2.2/2.35/2.5), (3.3/3.4/3.5)]
5	Exponential	[λ]	[(0.2/0.25/0.3)]
6	Gamma	[scale, shape]	[(2.1/2.2/2.3), (3.2/3.35/3.5)]

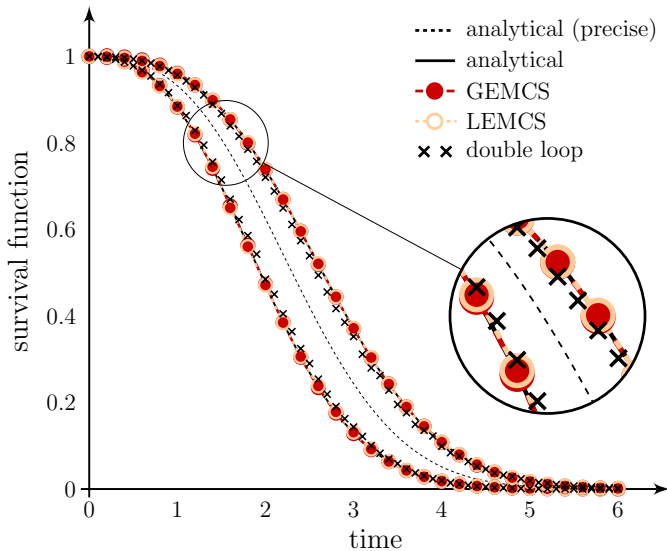

Figure 9: Survival function bounds of the complex system, displayed in Fig. 8, via double loop approach, LEMCS algorithm, GEMCS algorithm and analytically.

of rare failure events, as stated in [61] for both original NISS methods, also for the adapted method proposed in this work, instabilities may occur, depending on the sample size. Guidance on selecting an appropriate sample size is provided at the end of this section. If rare failure events are of special concern, it is recommended to use the NISS methods driven by advanced stochastic simulation techniques such as subset simulation and line sampling, see [75, 77, 78] for more details.

The difference between both algorithms is especially apparent for complex systems such as the one considered in Fig. 8, with various component types and various underlying multi-parametric and imprecise failure distribution functions. However, for less complex systems with single-parametric distribution functions of the same type as given for the axial compressor model in the previous section, the LEMCS performs equally well at both bounds and the errors are barely different from those of the GEMCS. Similar to the previous analysis of the axial compressor, the traditional double loop approach provides substantially worse approximations despite a significantly larger sample size, as clearly shown in Fig. 9, with errors of $\bar{\delta}_{DoubleLoop} = 2.07\%$ and $\underline{\delta}_{DoubleLoop} = 1.93\%$. Again, as in the previous case

Table 2: Non-trivial survival signature values of the complex system, shown in Fig. 8 — Part 1.

l_1	l_2	l_3	l_4	l_5	l_6	$\Phi(l_1, \dots, l_6)$
3	1	[1,2]	0	1	0	1/20
3	1	[0,1,2]	[0,1]	0	1	1/20
3	1	0	1	1	[0,1]	1/20
3	1	0	0	1	1	1/20
3	2	[1,2]	[0,1]	0	1	1/10
3	2	[1,2]	0	1	0	1/10
3	2	0	1	1	[0,1]	1/10
3	2	0	1	0	1	1/10
3	2	0	0	[0,1]	1	1/10
3	1	[1,2]	1	1	[0,1]	1/10
3	1	[1,2]	0	1	1	1/10
3	3	[0,1,2]	[0,1]	0	1	3/20
3	3	[1,2]	0	1	0	3/20
3	3	0	1	1	[0,1]	3/20
3	3	0	0	1	1	3/20
3	4	[0,1,2]	[0,1]	0	1	1/5
3	4	[1,2]	0	1	0	1/5
3	4	0	1	1	[0,1]	1/5
3	4	0	0	1	1	1/5
3	2	[1,2]	1	1	[0,1]	1/5
3	2	[1,2]	0	1	1	1/5
4	1	[1,2]	[0,1]	0	1	1/5
4	1	[1,2]	0	1	0	1/5
4	1	0	1	1	[0,1]	1/5
4	1	0	0	[0,1]	1	1/5
4	1	0	1	0	1	1/5
3	3	[1,2]	1	1	[0,1]	3/10
3	3	[1,2]	0	1	1	3/10

Table 3: Non-trivial survival signature values of the complex system, shown in Fig. 8 — Part 2.

l_1	l_2	l_3	l_4	l_5	l_6	$\Phi(l_1, \dots, l_6)$
4	2	[0,1,2]	[0,1]	0	1	11/30
4	2	[1,2]	0	1	0	11/30
4	2	0	1	1	[0,1]	11/30
4	2	0	0	1	1	11/30
3	4	[1,2]	1	1	[0,1]	2/5
3	4	[1,2]	0	1	1	2/5
4	1	[1,2]	1	1	[0,1]	2/5
4	1	[1,2]	0	1	1	2/5
4	3	[0,1,2]	[0,1]	0	1	1/2
4	3	[1,2]	0	1	0	1/2
4	3	0	1	1	[0,1]	1/2
4	3	0	0	1	1	1/2
5	1	[0,1,2]	[0,1]	0	1	1/2
5	1	[1,2]	0	1	0	1/2
5	1	0	1	1	[0,1]	1/2
5	1	0	0	1	1	1/2
4	4	[0,1,2]	[0,1]	0	1	3/5
4	4	[1,2]	0	1	0	3/5
4	4	0	1	1	[0,1]	3/5
4	4	0	0	1	1	3/5
4	2	[1,2]	1	1	[0,1]	2/3
4	2	[1,2]	0	1	1	2/3
4	[3,4]	[1,2]	1	1	[0,1]	4/5
4	[3,4]	[1,2]	0	1	1	4/5
5	2	[0,1,2]	[0,1]	0	1	5/6
5	2	[1,2]	0	1	0	5/6
5	2	0	1	1	[0,1]	5/6
5	2	0	0	1	1	5/6

study, to achieve the same quality of results with the double loop approach as with the LEMCS or GEMCS, significantly more samples than the 5 000 000 would be required.

In Fig. 10 a convergence study for the complex system, illustrated in Fig. 8, is shown. Both algorithms are considered: On the left, the results of the GEMCS and, on the right, the results of the LEMCS algorithm are depicted. The graphs display the relative error between the results of the proposed estimator algorithms and the analytically evaluated survival function bounds, plotted over various sample sizes with 500 evaluations each, reaching from 100 up to 250 000 samples. On the top, the relative error is evaluated for the upper survival function bound and, on the bottom, the relative error is evaluated for the lower survival function bound. The errors decrease significantly with increasing sample size and, clearly, for both algorithms and both bounds convergence is to observe. For the upper bound of the survival function via LEMCS algorithm, even small sample sizes are sufficient to yield low median errors and variances compared to the GEMCS results due to the specific choice of θ^* . In contrast, for the lower bound, the LEMCS performs significantly worse than the GEMCS.

This demonstrates the superior global performance of the GEMCS algorithm compared to the LEMCS, while the LEMCS algorithm shows better local performance. However, considering the GEMCS algorithm, the slightly larger upper median error indicates the upper survival function bound as a more challenging region for the global estimator. As stated in Section 4.2 for exponential distributions, this observation relates to the point that the support of the sampling density should ideally coincide with the support of the density with parameters varying in their imprecise intervals, see [61]. However, this condition is not given for the majority of GEMCS samples at the upper bound, leading to the slightly worse results compared to the lower bound.

As a supplementary decision-making indicator, the coefficient of variation can be considered to adaptively specify the required sample size. For instance, a threshold can be set for the coefficient of variation, e.g., (5%). If the estimated coefficient is above this threshold, more samples should be considered in order to reduce the variation.

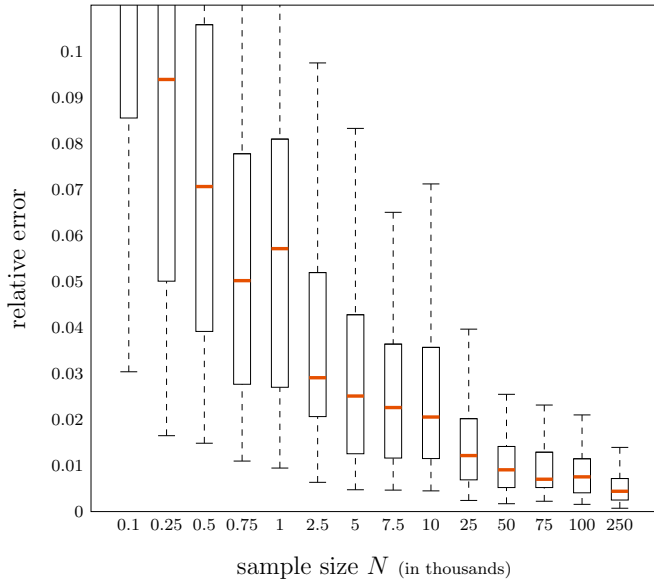

(a) GEMCS algorithm for upper bound

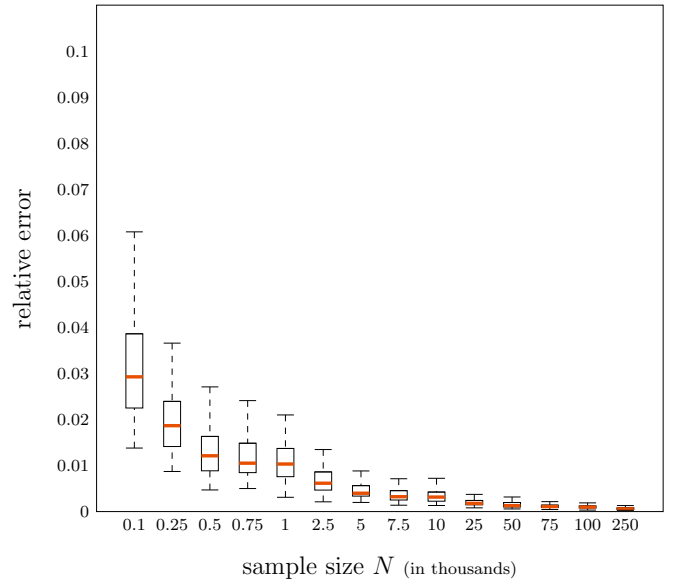

(b) LEMCS algorithm for upper bound

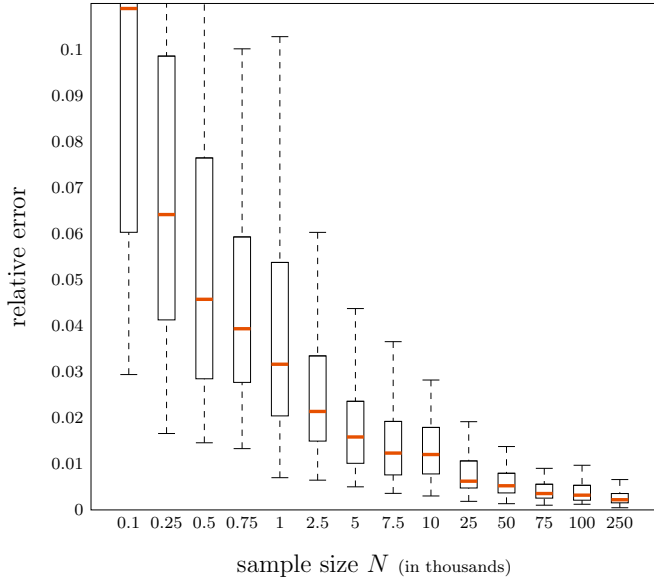

(c) GEMCS algorithm for lower bound

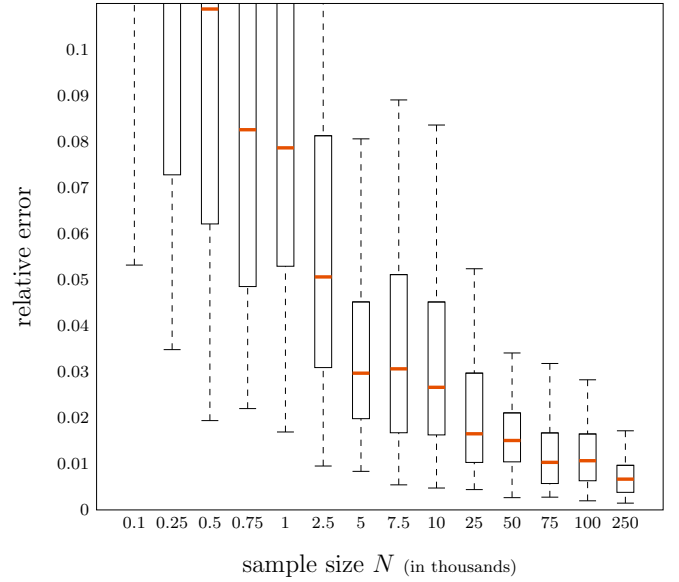

(d) LEMCS algorithm for lower bound

Figure 10: Convergence study of the GEMCS and LEMCS algorithms with the relative error of the corresponding survival function bounds with respect to the sample size over 500 evaluations each.

5.3. Imprecision Decision-Making

Given the fuzzy numbers specified in Tab. 1, the spectrum of imprecision is represented by means of a repeated p-box analysis as described in Section 3.3. The nested p-box analysis conducted via the GEMCS algorithm provides further survival function bounds of the complex system, corresponding to different α -levels, as shown in Fig. 11. Due to the separation between topological and probability structure, the survival signature does not have to be recalculated, neither for parameter variations within an α -level, nor for each new α -level, only the probability structure has

to be adapted. Consequently, for each α -level only a single stochastic simulation, according to Section 3.2, has to be performed. This enables comprehensive reliability analyses with substantially reduced cost compared to traditional approaches. In order to perform decision-making concerning the reduction of system components inherent imprecision, reliability requirements can be established, according to Section 3.4. In this case study, requirements are arbitrarily assumed with $\mathcal{R} = \{(t_1, R_1), (t_2, R_2), (t_3, R_3)\} = \{(1.5, 0.76), (2, 0.49), (3, 0.21)\}$, as illustrated in Fig. 11. Due to $\alpha_{cr} = \arg \min_{\alpha} \{\hat{R}_s^{\alpha}(t) | \hat{R}_s^{\alpha}(t_j) \geq R_j, (t_j, R_j) \in$

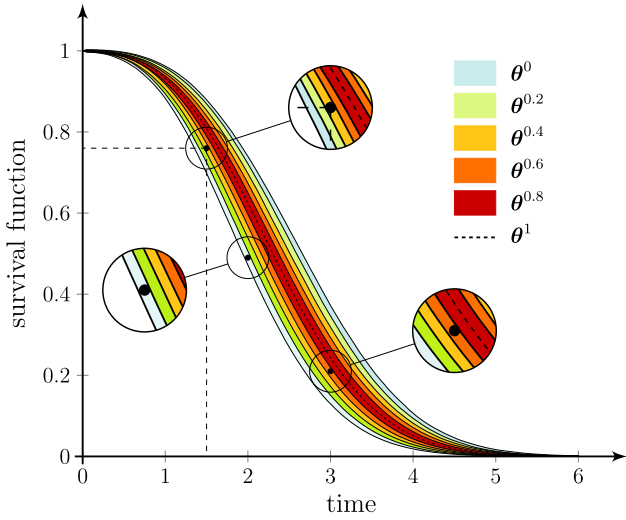

Figure 11: Survival function bounds of the complex system, displayed in Fig. 8, via GEMCS algorithm with fuzzy probability approximation.

$\mathcal{R} \forall j = 1, 2, 3\} = \arg \min_{\alpha} \{\hat{R}_s^{\alpha}(t) | \hat{R}_s^{\alpha}(1.5) \geq 0.76, \hat{R}_s^{\alpha}(2) \geq 0.49, \hat{R}_s^{\alpha}(3) \geq 0.21\} = \arg \min_{\alpha} \{\hat{R}_s^{0.8}(t), \hat{R}_s^1(t)\} = 0.8$. Note that $\hat{R}_s^1(t) = \hat{R}_s^1(t) = \hat{R}_s^1(t)$. Imprecision should be reduced at least up to a level of $\alpha = 0.8$ for all component types corresponding to the tuple of parameter intervals of $\theta_{cr} = (\theta_1^{0.8}, \theta_2^{0.8}, \dots, \theta_{10}^{0.8})$ with $\theta_1^{0.8} = [3.92, 4.08]$, $\theta_2^{0.8} = [2.22, 2.28]$, $\theta_3^{0.8} = [0.12, 0.18]$, $\theta_4^{0.8} = [3.02, 3.08]$, $\theta_5^{0.8} = [0.92, 0.98]$, $\theta_6^{0.8} = [2.32, 2.38]$, $\theta_7^{0.8} = [3.38, 3.42]$, $\theta_8^{0.8} = [4.00, 4.33]$, $\theta_9^{0.8} = [3.32, 3.38]$, $\theta_{10}^{0.8} = [2.18, 2.22]$.

6. Conclusion and Outlook

The present paper introduces a novel methodology supporting decision-making in the context of system reliability analysis, taking into account imprecisions. It allows to efficiently estimate the system reliability in design and maintenance processes, considering uncertainty in various levels, underlying the system component behavior. Thereby, decision-makers are enabled to identify a bearable level of imprecision that still ensures acceptable system reliability.

The proposed method consists of the sophisticated union of the concept of survival signature with two adapted extended MCS methods (NISS methods), thus representing a novel development combining two approaches from two different fields. Considering imprecision into the probabilistic structure by means of fuzzy probabilities and utilizing a nested p-box analysis for approximating this fuzziness allows for the ability of critical imprecision identification. The provided method combines both tremendous advantages of its two main components: 1. the application of the concept of survival signature dramatically reduces the computational effort for the analysis, since once it has been computed, any number of probability structures can be tested without having to recompute it and 2. the utilization

of both adapted NISS methods is accompanied by the necessity of only a single stochastic simulation per considered uncertainty level and consequently a substantially reduced sample size compared to traditional approaches, leading to another significant improvement of efficiency. Precisely these two characteristics and the symbiosis between them make the proposed methodology so efficient and widely applicable.

The novel approach is employed to the functional model of an axial compressor as well as to an arbitrary complex system. A comparison of analytical and numerical results proves the applicability of the method. However, in general, the LEMCS exhibits more local accuracy, while the GEMCS possesses better global performance and leads to superior results, especially for systems with complex imprecise probability structure. In terms of choice of method and application area, the LEMCS is preferable if accurate local performance is required and the knowledge for an educated guess of θ^* is available. While GEMCS should be applied if no prior knowledge about the uncertain system behavior is present. Further, a combination of both methods can be practical as well. First, GEMCS can be utilized to evaluate the neighborhood in which the parameter vector θ yields the critical survival function bound. Second, LEMCS can be applied to compute the results in the desired area of interest more accurately.

Further research should address the challenge of computing the survival signature for lifelike, large and complex systems with components of various types since it is highly demanding or even unfeasible. Thus, improved methods for determining the survival signature or enhanced methods for approximations are required. In addition, future work of the authors will address an improved rare failure event estimation and further performance improvements, such as the utilization of an HDMR.

Acknowledgment

Funded by the Deutsche Forschungsgemeinschaft (DFG, German Research Foundation) SFB 871/3 119193472 and Sino-German Center for Research Promotion (Sino-German Mobility Program), Project number M-0175.

References

- [1] W. ElMaraghy, H. ElMaraghy, T. Tomiyama, L. Monostori, Complexity in engineering design and manufacturing, *CIRP Annals* 61 (2) (2012) 793–814. doi:10.1016/j.cirp.2012.05.001.
- [2] J. Bongaarts, Human population growth and the demographic transition, *Philosophical Transactions of the Royal Society B: Biological Sciences* 364 (1532) (2009) 2985–2990. doi:10.1098/rstb.2009.0137.
- [3] A. Lisnianski, G. Levitin, *Multi-State System Reliability: Assessment, Optimization and Applications*, Vol. 6, World Scientific, 2003. doi:10.1142/5221.
- [4] M. Rausand, A. Høyland, *System Reliability Theory: Models, Statistical Methods, and Applications*, John Wiley & Sons, 2004. doi:10.1002/9780470316900.ch12.

- [5] E. Zio, Reliability engineering: Old problems and new challenges, *Reliability engineering & system safety* 94 (2) (2009) 125–141. doi:10.1016/j.ress.2008.06.002.
- [6] E. Zio, *The Monte Carlo Simulation Method for System Reliability and Risk Analysis*, Springer, 2013. doi:10.1007/978-1-4471-4588-2.
- [7] S.-H. G. Teng, S.-Y. M. Ho, Failure mode and effects analysis: An integrated approach for product design and process control, *International journal of quality & reliability management* 13 (5) (1996) 8–26. doi:10.1108/02656719610118151.
- [8] D. H. Stamatis, *Failure mode and effect analysis: FMEA from theory to execution*, 2nd Edition, ASQ Quality Press, 2003.
- [9] M. Modarres, *What every engineer should know about reliability and risk analysis*, Vol. 30, CRC Press, 1992.
- [10] M. Čepin, B. Mavko, A dynamic fault tree, *Reliability Engineering & System Safety* 75 (1) (2002) 83–91. doi:10.1016/S0951-8320(01)00121-1.
- [11] H. Aliee, M. Glaß, F. Reimann, J. Teich, Automatic success tree-based reliability analysis for the consideration of transient and permanent faults, in: *2013 Design, Automation & Test in Europe Conference & Exhibition (DATE)*, IEEE, 2013, pp. 1621–1626. doi:10.7873/DATE.2013.329.
- [12] E. Patelli, G. Feng, F. P. Coolen, T. Coolen-Maturi, Simulation methods for system reliability using the survival signature, *Reliability Engineering & System Safety* 167 (2017) 327–337. doi:10.1016/j.ress.2017.06.018.
- [13] J. B. Dugan, S. J. Bavuso, M. A. Boyd, Fault trees and markov models for reliability analysis of fault-tolerant digital systems, *Reliability Engineering & System Safety* 39 (3) (1993) 291–307. doi:10.1016/0951-8320(93)90005-J.
- [14] N. Sadou, H. Demmou, Reliability analysis of discrete event dynamic systems with Petri nets, *Reliability Engineering & System Safety* 94 (11) (2009) 1848–1861. doi:10.1016/j.ress.2009.06.006.
- [15] T. Jiang, Y. Liu, Parameter inference for non-repairable multi-state system reliability models by multi-level observation sequences, *Reliability Engineering & System Safety* 166 (2017) 3–15.
- [16] J. Mi, Y.-F. Li, W. Peng, H.-Z. Huang, Reliability analysis of complex multi-state system with common cause failure based on evidential networks, *Reliability Engineering & System Safety* 174 (2018) 71–81.
- [17] J. Guo, Z. S. Li, J. J. Jin, System reliability assessment with multilevel information using the bayesian melding method, *Reliability Engineering & System Safety* 170 (2018) 146–158.
- [18] X. Yang, Y. Liu, C. Mi, C. Tang, System reliability analysis through active learning kriging model with truncated candidate region, *Reliability Engineering & System Safety* 169 (2018) 235–241.
- [19] M. Xiao, J. Zhang, L. Gao, A system active learning kriging method for system reliability-based design optimization with a multiple response model, *Reliability Engineering & System Safety* 199 (2020) 106935.
- [20] X.-Y. Li, H.-Z. Huang, Y.-F. Li, Reliability analysis of phased mission system with non-exponential and partially repairable components, *Reliability Engineering & System Safety* 175 (2018) 119–127.
- [21] A. K. Verma, S. Ajit, D. R. Karanki, et al., *Reliability and Safety Engineering*, Vol. 43, Springer, 2010. doi:10.1007/978-1-84996-232-2.
- [22] M. Modarres, M. P. Kaminskiy, V. Krivtsov, *Reliability engineering and risk analysis: a practical guide*, CRC press, 2016.
- [23] D. W. Coit, E. Zio, The evolution of system reliability optimization, *Reliability Engineering & System Safety* 192 (2019) 106259.
- [24] G. Levitin, L. Xing, H. Ben-Haim, Y. Dai, Multi-state systems with selective propagated failures and imperfect individual and group protections, *Reliability Engineering & System Safety* 96 (12) (2011) 1657–1666. doi:10.1016/j.ress.2011.08.002.
- [25] E. Zaitseva, V. Levashenko, Construction of a reliability structure function based on uncertain data, *IEEE Transactions on Reliability* 65 (4) (2016) 1710–1723. doi:10.1109/TR.2016.2578948.
- [26] F. P. Coolen, T. Coolen-Maturi, L. J. Aslett, G. Walter, Imprecise system reliability using the survival signature, *ICAMER'16 : Proceedings of the 1st International Conference on Applied Mathematics in Engineering and Reliability (2016)* 207–214.
- [27] P. J. Boland, F. J. Samaniego, The signature of a coherent system and its applications in reliability, in: *Mathematical Reliability: An Expository Perspective*, Springer, 2004, pp. 3–30. doi:10.1007/978-1-4419-9021-1_1.
- [28] F. J. Samaniego, *System Signatures and their Applications in Engineering Reliability*, Vol. 110, Springer Science & Business Media, 2007. doi:10.1007/978-0-387-71797-5.
- [29] F. P. Coolen, T. Coolen-Maturi, Generalizing the signature to systems with multiple types of components, in: *Complex Systems and Dependability*, Springer, 2013, pp. 115–130. doi:10.1007/978-3-642-30662-4_8.
- [30] F. P. Coolen, T. Coolen-Maturi, The structure function for system reliability as predictive (imprecise) probability, *Reliability Engineering & System Safety* 154 (2016) 180–187. doi:10.1016/j.ress.2016.06.008.
- [31] L. J. Aslett, F. P. Coolen, S. P. Wilson, Bayesian inference for reliability of systems and networks using the survival signature, *Risk Analysis* 35 (9) (2014) 1640–1651. doi:10.1111/risa.12228.
- [32] Y. Li, F. P. Coolen, C. Zhu, J. Tan, Reliability assessment of the hydraulic system of wind turbines based on load-sharing using survival signature, *Renewable Energy* 153 (2020) 766–776. doi:10.1016/j.renene.2020.02.017.
- [33] J. Behrendorf, S. Brandt, M. Broggi, M. Beer, Efficient approximation of the survival signature for large networks, in: *Proceedings of the 6th International Symposium on Reliability Engineering and Risk Management*, 2018. doi:10.3850/978-981-11-2726-7_CRR14.
- [34] S. Reed, An efficient algorithm for exact computation of system and survival signatures using binary decision diagrams, *Reliability Engineering & System Safety* 165 (2017) 257–267.
- [35] F. P. Coolen, T. Coolen-Maturi, A. H. Al-Nefaiee, Nonparametric predictive inference for system reliability using the survival signature, *Proceedings of the Institution of Mechanical Engineers, Part O: Journal of Risk and Reliability* 228 (5) (2014) 437–448. doi:10.1177/1748006X14526390.
- [36] H. George-Williams, G. Feng, F. P. Coolen, M. Beer, E. Patelli, Extending the survival signature paradigm to complex systems with non-repairable dependent failures, *Proceedings of the Institution of Mechanical Engineers, Part O: Journal of Risk and Reliability* 233 (4) (2018) 505–519. doi:10.1177/1748006X18808085.
- [37] G. Feng, H. George-Williams, E. Patelli, F. Coolen, M. Beer, An efficient reliability analysis on complex non-repairable systems with common-cause failures, in: *Safety and Reliability - Safe Societies in a Changing World*, Taylor & Francis Group, 2018, pp. 2531–2538. doi:10.1201/9781351174664-318.
- [38] J. Behrendorf, M. Broggi, M. Beer, Reliability analysis of networks interconnected with copulas, *ASCE-ASME Journal of Risk and Uncertainty in Engineering Systems, Part B: Mechanical Engineering* 5 (4) (2019) 041006-1 – 041006-9. doi:10.1115/1.4044043.
- [39] A. Certa, F. Hopps, R. Inghilleri, C. M. La Fata, A dempster-shafer theory-based approach to the failure mode, effects and criticality analysis (fmeca) under epistemic uncertainty: application to the propulsion system of a fishing vessel, *Reliability Engineering & System Safety* 159 (2017) 69–79. doi:10.1016/j.ress.2016.10.018.
- [40] R. Rocchetta, M. Broggi, E. Patelli, Do we have enough data? robust reliability via uncertainty quantification, *Applied Mathematical Modelling* 54 (2018) 710–721. doi:10.1016/j.apm.2017.10.020.
- [41] Y. Ben-Haim, Uncertainty, probability and information-gaps, *Reliability Engineering & System Safety* 85 (1) (2004) 249–266. doi:10.1016/j.ress.2004.03.015.
- [42] C. Simon, F. Bicking, Hybrid computation of uncertainty in reliability analysis with p-box and evidential networks, *Re-*

- liability Engineering & System Safety 167 (2017) 629–638. doi:10.1016/j.res.2017.04.015.
- [43] R. Rocchetta, E. Patelli, A post-contingency power flow emulator for generalized probabilistic risks assessment of power grids, Reliability Engineering & System Safety 197 (2020) 106817. doi:10.1016/j.res.2020.106817.
- [44] Q. Jiang, C.-H. Chen, A numerical algorithm of fuzzy reliability, Reliability Engineering & System Safety 80 (3) (2003) 299–307. doi:10.1016/S0951-8320(03)00055-3.
- [45] S. Kabir, Y. Papadopoulos, A review of applications of fuzzy sets to safety and reliability engineering, International Journal of Approximate Reasoning 100 (2018) 29–55. doi:10.1016/j.ijar.2018.05.005.
- [46] J. M. Aughenbaugh, C. J. J. Paredis, The value of using imprecise probabilities in engineering design, Journal of Mechanical Design 128 (4) (2005) 969–979. doi:10.1115/1.2204976.
- [47] A. Der Kiureghian, O. Ditlevsen, Aleatory or epistemic? Does it matter?, Structural Safety 31 (2) (2009) 105–112. doi:10.1016/j.strusafe.2008.06.020.
- [48] S. Ferson, C. A. Joslyn, J. C. Helton, W. L. Oberkampf, K. Sentz, Summary from the epistemic uncertainty workshop: consensus amid diversity, Reliability Engineering & System Safety 85 (1-3) (2004) 355–369. doi:10.1016/j.res.2004.03.023.
- [49] J. C. Helton, W. L. Oberkampf, Alternative representations of epistemic uncertainty, Reliability Engineering & System Safety 85 (1-3) (2004) 1–10. doi:10.1016/j.res.2004.03.001.
- [50] M. Beer, S. Ferson, V. Kreinovich, Imprecise probabilities in engineering analyses, Mechanical Systems and Signal Processing 37 (1-2) (2013) 4–29. doi:10.1016/j.ymsp.2013.01.024.
- [51] G. Feng, E. Patelli, M. Beer, F. P. Coolen, Imprecise system reliability and component importance based on survival signature, Reliability Engineering & System Safety 150 (2016) 116–125. doi:10.1016/j.res.2016.01.019.
- [52] E. Hofer, M. Kloos, B. Krzykacz-Hausmann, J. Peschke, M. Wolterek, An approximate epistemic uncertainty analysis approach in the presence of epistemic and aleatory uncertainties, Reliability Engineering & System Safety 77 (3) (2002) 229–238. doi:10.1016/S0951-8320(02)00056-X.
- [53] D. A. Alvarez, On the calculation of the bounds of probability of events using infinite random sets, International Journal of Approximate Reasoning 43 (3) (2006) 241–267. doi:https://doi.org/10.1016/j.ijar.2006.04.005.
- [54] A. Sarkar, J. Guo, N. Siegmund, S. Apel, K. Czarnecki, Cost-efficient sampling for performance prediction of configurable systems (T), in: 2015 30th IEEE/ACM International Conference on Automated Software Engineering (ASE), IEEE, 2015, pp. 342–352. doi:10.1109/ASE.2015.45.
- [55] H. Zhang, R. L. Mullen, R. L. Muhanna, Interval monte carlo methods for structural reliability, Structural Safety 32 (3) (2010) 183–190. doi:10.1016/j.strusafe.2010.01.001.
- [56] H. Zhang, Interval importance sampling method for finite element-based structural reliability assessment under parameter uncertainties, Structural Safety 38 (2012) 1–10. doi:10.1016/j.strusafe.2012.01.003.
- [57] M. Eldred, L. Swiler, G. Tang, Mixed aleatory-epistemic uncertainty quantification with stochastic expansions and optimization-based interval estimation, Reliability Engineering & System Safety 96 (9) (2011) 1092–1113. doi:10.1016/j.res.2010.11.010.
- [58] H.-R. Bae, R. V. Grandhi, R. A. Canfield, An approximation approach for uncertainty quantification using evidence theory, Reliability Engineering & System Safety 86 (3) (2004) 215–225. doi:10.1016/j.res.2004.01.011.
- [59] H. Liu, C. Jiang, X. Jia, X. Long, Z. Zhang, F. Guan, A new uncertainty propagation method for problems with parameterized probability-boxes, Reliability Engineering & System Safety 172 (2018) 64–73. doi:10.1016/j.res.2017.12.004.
- [60] X. Yuan, M. G. Faes, S. Liu, M. A. Valdebenito, M. Beer, Efficient imprecise reliability analysis using the augmented space integral, Reliability Engineering & System Safety 210 (2021) 107477. doi:10.1016/j.res.2021.107477.
- [61] P. Wei, J. Song, S. Bi, M. Broggi, M. Beer, Z. Lu, Z. Yue, Non-intrusive stochastic analysis with parameterized imprecise probability models: I. Performance estimation, Mechanical Systems and Signal Processing 124 (2019) 349–368. doi:10.1016/j.ymsp.2019.01.058.
- [62] J. M. Bernardo, The concept of exchangeability and its applications, Far East Journal of Mathematical Sciences 4 (1996) 111–122.
- [63] E. Nikolaidis, Types of uncertainty in design decision making, in: D. M. G. Efstratios Nikolaidis, S. Singhal (Eds.), Engineering Design Reliability Handbook, CRC Press, 2004, Ch. 2, pp. 137–156. doi:10.1201/9780203483930.
- [64] S. Ferson, L. R. Ginzburg, Different methods are needed to propagate ignorance and variability, Reliability Engineering & System Safety 54 (2-3) (1996) 133–144. doi:10.1016/S0951-8320(96)00071-3.
- [65] W. L. Oberkampf, J. C. Helton, C. A. Joslyn, S. F. Wojtkiewicz, S. Ferson, Challenge problems: uncertainty in system response given uncertain parameters, Reliability Engineering & System Safety 85 (1-3) (2004) 11–19. doi:10.1016/j.res.2004.03.002.
- [66] E. Hofer, When to separate uncertainties and when not to separate, Reliability Engineering & System Safety 54 (2-3) (1996) 113–118. doi:10.1016/S0951-8320(96)00068-3.
- [67] P. Baraldi, E. Zio, A combined Monte Carlo and possibilistic approach to uncertainty propagation in event tree analysis, Risk Analysis: An International Journal 28 (5) (2008) 1309–1326. doi:10.1111/j.1539-6924.2008.01085.x.
- [68] C. J. Roy, W. L. Oberkampf, A comprehensive framework for verification, validation, and uncertainty quantification in scientific computing, Computer Methods in Applied Mechanics and Engineering 200 (25-28) (2011) 2131–2144. doi:10.1016/j.cma.2011.03.016.
- [69] S. Bradley, Imprecise probabilities, in: Computer Simulation Validation, Springer, 2019, pp. 525–540. doi:10.1007/978-3-319-70766-2_21.
- [70] W. L. Oberkampf, C. J. Roy, Verification and Validation in Scientific Computing, Cambridge University Press, 2010. doi:10.1017/CB09780511760396.
- [71] B. Möller, M. Beer, Engineering computation under uncertainty – Capabilities of non-traditional models, Computers & Structures 86 (10) (2008) 1024–1041. doi:10.1016/j.compstruc.2007.05.041.
- [72] M. Beer, S. Ferson, Fuzzy probability in engineering analyses, in: B. M. Ayyub (Ed.), Vulnerability, Uncertainty, and Risk: Analysis, Modeling, and Management, American Society of Civil Engineers, 2012, pp. 53–61. doi:10.1061/41170(400)7.
- [73] B. Möller, W. Graf, M. Beer, J.-U. Sickert, Fuzzy probabilistic method and its application for the safety assessment of structures, in: Proceedings of the European Conference on Computational Mechanics, 2001.
- [74] J. J. Buckley, Fuzzy Probabilities: New Approach and Applications, Vol. 115 of Studies in Fuzziness and Soft Computing, Springer, 2005. doi:10.1007/3-540-32388-0.
- [75] P. Wei, J. Song, S. Bi, M. Broggi, M. Beer, Z. Lu, Z. Yue, Non-intrusive stochastic analysis with parameterized imprecise probability models: II. Reliability and rare events analysis, Mechanical Systems and Signal Processing 126 (2019) 227–247. doi:10.1016/j.ymsp.2019.02.015.
- [76] P. Wei, Z. Lu, J. Song, Extended monte carlo simulation for parametric global sensitivity analysis and optimization, AIAA journal 52 (4) (2014) 867–878.
- [77] J. Song, M. Valdebenito, P. Wei, M. Beer, Z. Lu, Non-intrusive imprecise stochastic simulation by line sampling, Structural Safety 84 (2020) 101936. doi:10.1016/j.strusafe.2020.101936.
- [78] J. Song, P. Wei, M. Valdebenito, M. Beer, Adaptive reliability analysis for rare events evaluation with global imprecise line sampling, Computer Methods in Applied Mechanics and Engineering 372 (2020) 113344. doi:10.1016/j.cma.2020.113344.
- [79] J. Song, P. Wei, M. Valdebenito, S. Bi, M. Broggi, M. Beer,

Z. Lei, Generalization of non-intrusive imprecise stochastic simulation for mixed uncertain variables, *Mechanical Systems and Signal Processing* 134 (2019) 106316. doi:10.1016/j.ymssp.2019.106316.

- [80] S. Miro, T. Willeke, M. Broggi, J. Seume, M. Beer, Reliability analysis of an axial compressor based on one-dimensional flow modeling and survival signature, *ASCE-ASME Journal of Risk and Uncertainty in Engineering Systems, Part B: Mechanical Engineering* 5 (3) (2019) 031003. doi:10.1115/1.4043150.
- [81] B. Hellmich, J. Seume, Causes of acoustic resonance in a high-speed axial compressor, *ASME. J. Turbomach.* 130 (3) (2008) 031003. doi:10.1115/1.2775487.