

Internet of things-based photovoltaics parameter monitoring system using NodeMCU ESP8266

Tole Sutikno¹, Hendril Satrian Purnama², Anggit Pamungkas³, Abdul Fadlil⁴,
Ibrahim Mohd Alsofyani⁵, Mohd Hatta Jopri⁶

^{1,4}Department of Electrical Engineering, Universitas Ahmad Dahlan, Yogyakarta, Indonesia

^{1,2,3}Embedded Systems and Power Electronics Research Group, Yogyakarta, Indonesia

⁵Department of Electrical and Computer Engineering, Ajou University, Suwon, South Korea

⁶Faculty of Electrical and Electronic Engineering Technology, Universiti Teknikal Malaysia Melaka, Melaka, Malaysia

Article Info

Article history:

Received May 8, 2021

Revised Jun 28, 2021

Accepted Jul 12, 2021

Keywords:

ESP8266

Internet of things

Online monitoring

Photovoltaic

ThingSpeak

ABSTRACT

The use of the internet of things (IoT) in solar photovoltaic (PV) systems is a critical feature for remote monitoring, supervising, and performance evaluation. Furthermore, it improves the long-term viability, consistency, efficiency, and system maintenance of energy production. However, previous researchers' proposed PV monitoring systems are relatively complex and expensive. Furthermore, the existing systems do not have any backup data, which means that the acquired data could be lost if the network connection fails. This paper presents a simple and low-cost IoT-based PV parameter monitoring system, with additional backup data stored on a microSD card. A NodeMCU ESP8266 development board is chosen as the main controller because it is a system-on-chip (SOC) microcontroller with integrated Wi-Fi and low-power support, all in one chip to reduce the cost of the proposed system. The solar irradiance, ambient temperature, PV output voltage and PV output current, are measured with photo-diodes, DHT22, impedance dividers and ACS712. While, the PV output power is a product of the PV voltage and PV current. ThingSpeak, an open-source software, is used as a cloud database and data monitoring tool in the form of interactive graphics. The results showed that the system was designed to be highly accurate, reliable, simple to use, and low-cost.

This is an open access article under the [CC BY-SA](https://creativecommons.org/licenses/by-sa/4.0/) license.



Corresponding Author:

Tole Sutikno

Department of Electrical Engineering, Faculty of Industrial Technology

Universitas Ahmad Dahlan (UAD)

4th UAD Campus, 6th Floor, South Ringroad St., Banguntapan, Bantul, Yogyakarta 55191, Indonesia

Email: tole@ee.uad.ac.id

1. INTRODUCTION

The demand for renewable energy sources is growing in tandem with global energy demand. This is due to the worsening environmental impact caused by the use of fossil fueled power plants, which cause a big air pollution and not environmentally friendly. On the other hand, there are several forms of renewable energy-based electricity generation, with technology that is constantly improving [1]-[11].

Solar energy has recently emerged as the most appealing renewable energy source for bridging the gap between consumption and production of electrical energy. This is due to the dramatic cost reductions and advancements in photovoltaic (PV) technology, which is still rapidly evolving [12]-[14]. In addition, solar energy is also the cleanest, environmentally friendly, and abundant type of energy compared to other energy

sources. Furthermore, the PV technology can be the most efficient source of energy with modern monitoring and control systems [5], [6], [15]-[23].

The data collected during the operation of a PV system is very interesting, not only for determining whether the design goals were met, but also for improving the PV system's design and operation, as well as a general assessment of the PV technology's potential [24]. Moreover, it is necessary to control the PV's parameters in order to optimize it. A PV monitoring system's goal is to provide accurate data on a variety of parameters, including energy potential, energy extracted, fault identification, historical generation analysis, and associated energy losses [14], [25]. The literature has detailed descriptions of the classification of PV monitoring systems based on internet technologies, the data acquisition system used, and the monitoring system methods [16], [26]-[29].

The internet of things (IoT) technology is able to monitor and control many smart devices remotely. Many IoT based online and remote monitoring systems has been developed by researcher [30]-[38] such as: i) object monitoring [31], [39]; ii) parking space monitoring and management [32]; iii) environmental monitoring [33], [36]; 4) electricity power consumption monitoring [35]; and 5) Body health monitoring [30], [37]. Most of the developed device is using NodeMCU ESP8266 for the main processor and Wi-Fi provider because of the low-cost and low-power consumption module [31], [39]-[42].

In the area of renewable energy generations, especially on PV power generation systems, much research's that has been done to design and develop PV parameter monitoring systems, both offline and online are available in the literature [14], [43]-[51]. Due to the sensitivity of PV panels to environmental factors, data such as solar radiation, ambient temperature, weather, and electrical data are used to assess the condition of the PV station. This is why it's crucial to keep track the performance of a PV system at all times [52], [53].

Presently, the PV parameter monitoring system that has been developed by many researchers is still relatively complex and requires high production costs for small-to-medium scale PV applications, this is due to the use of a pyranometer sensor (as a measure of solar irradiance), the use of an expensive controller and also use of high paid monitoring software such as LABVIEW [54]. Besides this, the existing system also does not provide an offline data backup/storage feature, if the system's network fails, this may result in data loss [55].

In this paper, an IoT based PV parameter monitoring system is designed with low production costs for small-scale PV-based power generation applications (in this case for energy independent home applications). To achieve this goal, many costly components such as sensors and controllers are replaced with sensors and controllers that perform the same role but cost less and are readily available. Furthermore, instead of using special software that needs high service costs, such as LABVIEW, the monitoring software used was open-source and free IoT software. In addition, to prepare for any network failures, a MicroSD card-based offline data backup system is introduced.

2. RESEARCH SYSTEM DESIGN

IoT technology is used in the proposed system to track parameter data from PV via internet connection, including both environmental data (metrology) and electrical data (I and V). The microcontroller is used in an IoT-based PV monitoring system to capture, process, store, and analyse data from sensors based on the calculated parameters in the system. The microcontroller will send the data to the cloud server through a WiFi gateway after it has been processed.

2.1. The proposed IoT PV monitoring system

Figure 1 depicts a block diagram of the entire proposed system, which includes PV data in the form of environmental parameters collected from temperature and light sensors (to estimate the solar irradiance). The electrical parameters of PV, such as current and voltage, are obtained from the appropriate sensors. With the IoT protocol, the microcontroller collects, processes, data from sensors. Then the data transmit and store into offline data backup systems and cloud servers, respectively. The web-based and open-source software serves as a cloud database and visual data viewer can be accessed via Smartphone or personal computer (PC) via a web server.

2.2. Internet of things for PV monitoring system

The IoT allows smart microgrids to exchange information with more users and improves communication through a variety of infrastructures [3]. IoT plays a significant role in human everyday life by allowing the integration of many physical devices via the internet, where devices are intelligently linked, enabling new forms of communication between devices and humans, as well as between devices and the system itself, to share data, track, and manage devices from anywhere in the world using only an internet connection [54].

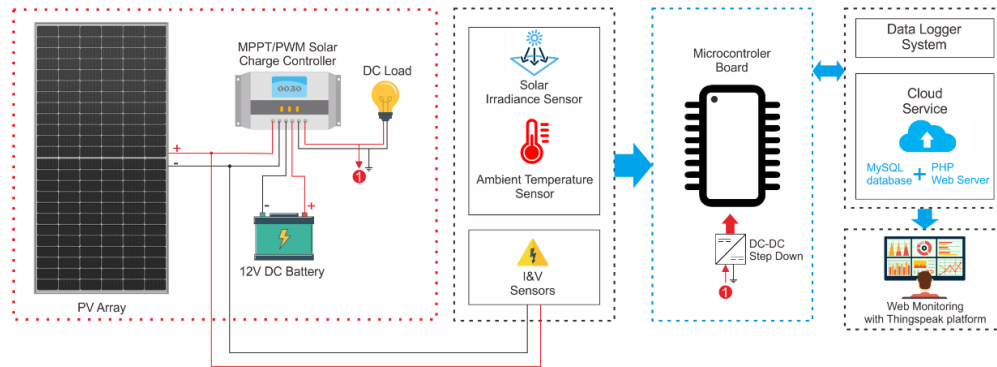

Figure 1. Block diagram of a proposed IoT-based PV monitoring system

IoT technology is used in the field of renewable energy, especially solar PV systems, to track important parameters affecting PV system output in real-time and online. The sensor and transducer provide these parameters, which are then sent to the microcontroller for analysis. Furthermore, PV plants and other power generation systems can be tracked using an IoT-based monitoring system to enhance analysis, quality, and system maintenance.

2.3. Display unit and cloud storage system

Continuous data acquisition necessitates graphic or visual data display capabilities, which can be accessed remotely and in real-time via a smartphone or PC. The application programming interface (API) that used for the display unit of the proposed system is an open-source IoT platform namely ThingSpeak. ThingSpeak enables the development of sensor logging applications, location tracking applications, and social networking things with customizable status updates. It allows users to collect, store, analyze, visualize and make decisions based on data that obtained from sensors.

3. EXPERIMENTAL SETUP

In this research, various sensors are used to measure various parameters of the PV system, such as solar irradiance (light intensity), ambient temperature, PV output current, PV output voltage, and PV output power. The acquired data from the sensor is transferred wirelessly to the cloud server using IoT protocol, then the data is displayed visually using ThingSpeak platform. The goal of the proposed system in this paper is to develop a simple, low-cost, and high-performance IoT solution for monitoring the electric and environmental data of PV solar farms, especially small-scale PV farms (on and off grid condition). It is essential to select sensor and controller hardware that is both low-cost and capable of providing highly accurate data acquisitions. The following are the low-cost sensors that can be used to quantify both environmental variation and electrical data:

- DHT22 is used to measure the temperature and humidity data.
- Photodiode sensor is used to measure the solar radiation intensity.
- ACS712 is used to measure the current produced by PV.
- Impedance divider sensor module is used to measure the voltage produced by PV.

Instead of DHT11, DHT22 is used to assess room temperature and humidity because it provides more precise data acquisition. Pyranometer sensor is replaced by a photodiode sensor due to measure the light intensity transmitted to the PV screen, resulting in lower device costs. The current sensor ACS712 and impedance divider are used to measure the generated power by PV.

The ESP8266 controller is chosen as the main processor of data acquisition systems because of its low-cost, low-power consumption and high-performance computational controller. In addition, the ESP8266 controller has many useful features, such as a built-in WiFi module, has a many general-purpose input/output (GPIO) ports, and a simple programming method. The open-source IoT platform ThingSpeak is used as a database and to visualise the acquired data with an interactive graph and dashboard in order to keep the system low-cost and easy to access and create. Besides, using non-open-source software such as LABVIEW cost would rise the cost due to costly software service payments. Furthermore, an offline backup data system comprised of RTC and MicroSD modules has been introduced to expand the database systems and serve as internal data storage systems that can be accessed when online data is unavailable.

3.1. Hardware design

Figure 2 shows the wiring diagram for the proposed system's main board. The key components of the device are the NodeMCU ESP8266, various sensors, the ADC module, the RTC, and the SD card module. Table 1 shows the complete data and usability of each device.

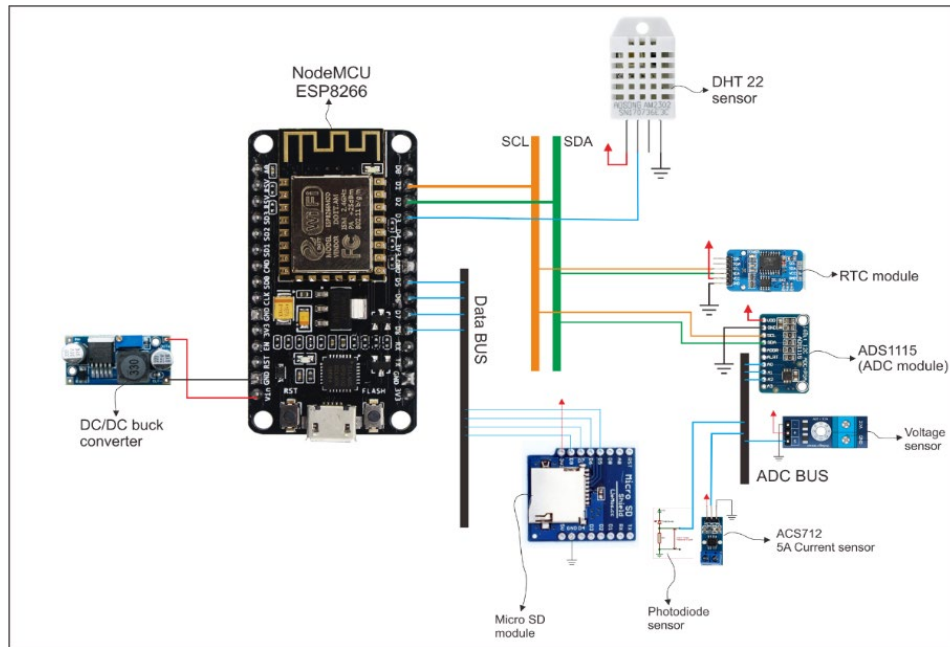

Figure 2. Schematic diagram of proposed system

Table 1. Research components

Component name	Function/usability
NodeMCU V3 ESP8266	Main controller
MicroSD Shield	Data logger storage
RTC module shield	Data logger time reference
INA219 Sensor	Voltage sensor
ACS712 5A Current Sensor	Current sensor
ADS1115	ADC 16bit reader
DHT22	Temperature sensor
Photodiode sensor	Solar irradiance level sensor
Solar Panel 50Wp	Power generator
PWM Solar Charge Controller	Charging controller
12V battery	Energy backup system
Inverter	System load

3.1.1. Photovoltaic system

In the proposed design system, the PV system consist of 50Wp monocrystalline PV panel, 10 A PWM solar charge controller, 12 V 7.2 Ah battery for energy backup, and 30W constant load.

3.1.2. Sensing unit

a) Current sensor

An ACS712 current sensor with a maximum operating range of 5 A was used in this study. Since this sensor can detect both AC and DC currents in a circuit, it can be used in a variety of applications. An Arduino, ESP8266, or another kind of microcontroller can be used to access this sensor. In principle, this sensor works with indirect sensing. The current flows through the onboard hall sensor circuit in its IC. The hall-effect sensor detects incoming current by generating a magnetic field. The hall effect sensor detects the magnetic field and produces a voltage proportional to it, which is then used to calculate the current.

b) Voltage sensor

The proposed system's voltage sensor is a voltage divider sensor that is used to read the value of the output voltage provided by the PV when the system is in service.

c) Temperature sensor

The DHT22 sensor is used in the PV monitoring system to measure temperature and humidity at the same time. It is a negative temperature coefficient (NTC) type thermistor that measures temperature and a humidity sensor that is resistant to changes in water content in the air, as well as a chip that performs some analogue to digital conversion (two-way single cable).

d) Irradiance sensor

The photodiode sensor was chosen as an irradiance sensor to replace the pyranometer sensor, which is rated as extremely costly, thereby raising the overall device cost. To obtain an accurate value, the photodiode sensor must be calibrated using an accurate solar irradiance sensor, such as a pyranometer.

3.1.3. NodeMCU ESP8266 based controller

NodeMCU is an open-source firmware and development kit that assists in the development of IoT-based application systems. NodeMCU was created to make it easier to use a sophisticated application programming interface (API) for IO hardware. APIs can help to reduce the amount of time spent configuring and manipulating hardware devices. The NodeMCU has the advantage of being programmable in a variety of programming languages and with an open-source IDE. The code for this study will be uploaded directly to the nodeMCU board using the Arduino IDE. Meanwhile, the ESP8266 is used as the WiFi integrated chip, and it is very small in size.

3.2. Software design

3.2.1. Thingspeak

ThingSpeak is an open-source internet of things (IoT) platform and API for storing and retrieving data from things that use HTTP over the Internet or a local area network (LAN). The internet of things (IoT) gives users access to a wide range of embedded devices and web services. Moreover, it is capable of collecting, storing, analyzing, visualizing, and acting on data from sensors or actuators such as Arduino, NodeMCU, Raspberry Pi, BeagleBone, and other hardware. ThingSpeak, for example, allows sensor logging and location tracking applications.

Additionally, it is a data collector that gathers data from nodeMCU devices and then loads it into the software environment for historical data analysis. A channel, which contains a data field, a position field, and a status field, is the most important part of the ThingSpeak operation. ThingSpeak features includes: (i) open API, (ii) real-time data collection, (iii) geolocation data, (iv) data processing, (v) data visualizations, (vi) device status messages, and (vii) plugins are the key features of ThingSpeak.

3.2.2. Monitoring algorithm

Figure 3 shows a flowchart of an IoT-based PV device monitoring algorithm. The proposed monitoring system start with the library definitions, variable parameters, and board setup. Then the system will check the availability of WiFi connectivity. If the connection is accessible, the controller will start to open and read the SD card folder file. Furthermore, if the system successfully reads the SD card folder file, the operation will proceed to read all of the system's sensors before reading the time reference from the RTC module. As a final point, the collected data will be written and stored into the SD card module. In addition, using the built-in WiFi gateway on the NodeMCU, the collected data will be sent to a cloud server. Until the device is deactivated, all procedures will be replicated.

4. RESULTS AND DISCUSSION

Figure 4 depicts an experimental system in which the PV is used as a power generator and the laptop is used to view graphic data obtained via the ThingSpeak platform. The electrical measurement device is used to verify the accuracy of the electric sensor, the breadboard is used to attach the sensor to the mainboard, the box contains the mainboard and the PWM solar charge controller, and the 12 V battery serves as an energy backup system.

Figure 5 shows the graphical data obtained from the ThingSpeak platform. Moreover, Figures 5(a) to (e) depict the PV parameter measurements, which include solar irradiation level, ambient temperature, PV output voltage and current, as well as the PV output power. The monitoring device's channel placement is shown in Figure 5(f). The linear relationship between solar irradiation, PV output current, and PV output power values indicates that the sensor readings and data collecting system are working appropriately. In around 30 seconds, the sensor collects, analyses, transmits, and stores the data into cloud server. Meanwhile, Table 2 tabulates the costs comparison of several key controllers used in the IoT-based PV monitoring system. This is to show that the proposed system's development costs are the lowest compare to others.

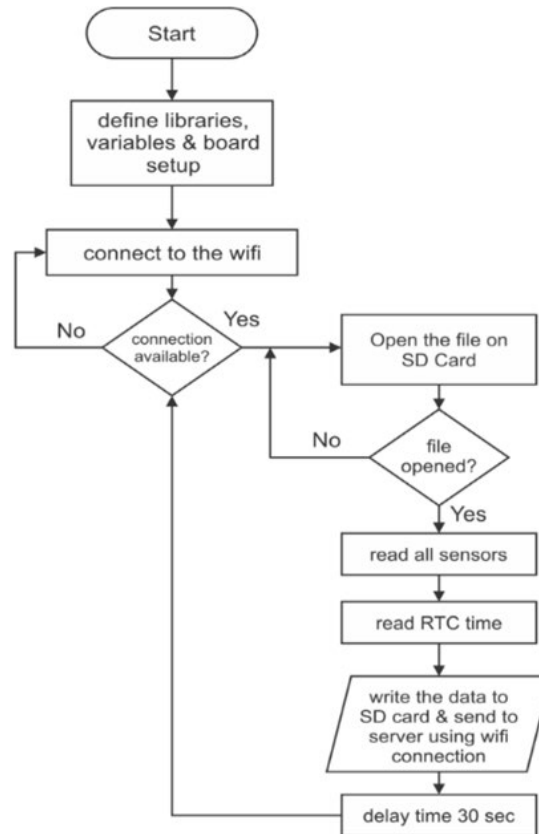

Figure 3. Flowchart of the proposed system

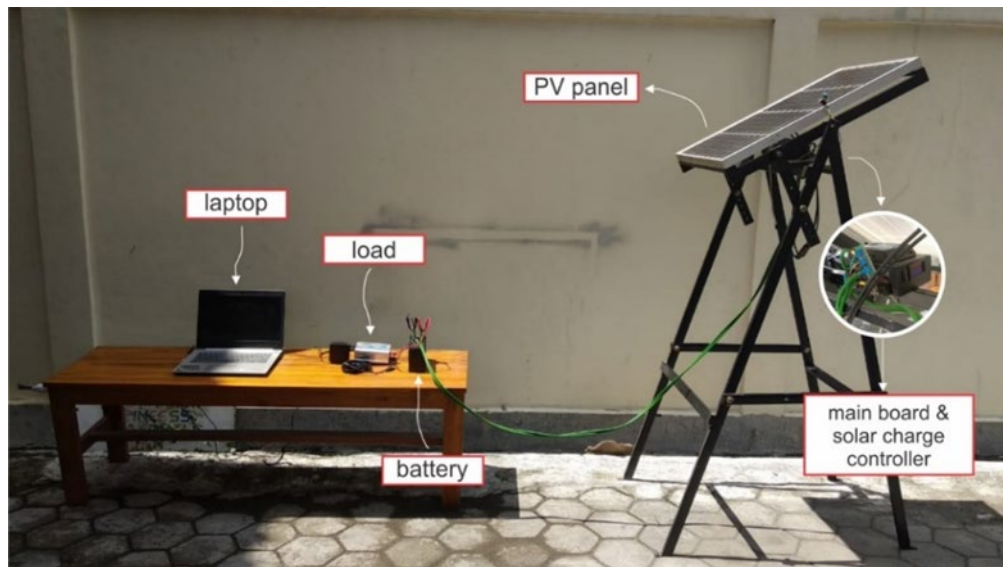

Figure 4. Experimental setup of the proposed system

In comparison to the other controllers, the Raspberry Pi [10] and BeagleBone Black [9] have the most efficient computational efficiency, but they are also the most costly and complex to programme. The cheapest controller is the PIC 16F877 [20], but it has the lowest computational efficiency and requires an external WiFi module to connect to the internet. Due to their easy programming and relatively high performance for many applications, the Arduino MEGA2560 and Arduino UNO R3 [4], [19] have become popular controllers.



Figure 5. Captured visual data from ThingSpeak platform; (a) ambient temperature; (b) PV voltage out; (c) PV current out; (d) PV power out; (e) solar irradiance level; (f) channel location

Table 2. Comparison of the controller for IOT monitoring systems

Paper	Main Controller	Characteristic of the Controller	Cost (\$)*	Built-in WiFi?
[45]	BeagleBone black	Very High computation Need external ADC	73,98	No
[16]	Arduino Mega2560	High power consumption Low computation Integrated ADCs	34,00	No
[55]	Arduino UNO R3	Low power consumption Low computation Integrated ADCs	22,00	No
[56]	PIC 16F877	Low power consumption Low computation Integrate ADCs	5,50	No
[46]	Raspberry Pi 3	Low power consumption High computation Need external ADC	42,99	Yes
[54]	ESP32	High power consumption Average level computation Integrated ADCs	10,99	Yes
Proposed	ESP8266	Low power consumption Average level computation Integrated ADCs Low power consumption	6,49	Yes

*Estimated cost of the main controller (amazon.com)

However, they still have a low computational level as compared to other controllers on the market, and they need an additional WiFi module for IoT applications. The ESP board series [18] was chosen for this proposed system due to its low cost and ability to perform reasonably high-level computation. In addition, the ESP board series has a built-in WiFi module and consumes very little electricity.

5. CONCLUSION

An IoT-based PV parameter monitoring system was introduced in this paper. The parameters such as solar irradiance, ambient temperature, PV output voltage, PV output current, and PV output power are all measured by the system. Moreover, solar irradiance, ambient temperature, PV output voltage, and PV output current are measured using photodiode, DHT22, impedance divider, and ACS712, respectively. Besides, PV output power is obtained from the product of PV voltage and PV current. The main controller of the system is the NodeMCU V3 ESP8266, which also has the ability to create a WiFi enabled gateway. As a result, the calculated parameters can be transferred wirelessly from the sensor to the cloud without the need for an external WiFi module. Finally, the acquired parameters are tracked on the Cloud server using ThingSpeak.

The selected components for the proposed system are low-cost and readily available on the market. The reliability of each components also a factor to consider. Finally, laboratory experiments are used to verify the proposed system. The outcome clearly show that the proposed system offers accurate result in monitoring the PV parameters. It is important to test the proposed system under a variety of environmental conditions over a prolonged period of time for future work.

ACKNOWLEDGEMENTS

We would like to thank Universitas Ahmad Dahlan (UAD) for funding this research under Leading Research Scheme (PUPS), contract No: PUPS-015/SP3/LPPM-UAD/2020; and Embedded System and Power Electronics Research Group (ESPERG) for providing the excellent support and cooperation to produce the work described in this paper.

REFERENCES

- [1] B. I. Yassine and A. Boumediene, "Renewable energies evaluation and linking to smart grid," *International Journal of Power Electronics and Drive Systems (IJPEDS)*, vol. 11, no. 1. pp. 107-118, 2020, doi: 10.11591/ijpeds.v11.i1.pp107-118.
- [2] C. U. Cassiani Ortiz, J. E. Candelo-Becerra, and F. E. Hoyos Velasco, "Electricity market strategies applied to microgrid development," *International Journal of Power Electronics and Drive Systems (IJPEDS)*, vol. 11, no. 1. pp. 530-546, 2020, doi: 10.11591/ijpeds.v11.i1.pp530-546.
- [3] Y. M. Esmail, A. H. Kasem Alaboudy, M. S. Hassan, and G. M. Dousoky, "Mitigating power quality disturbances in smart grid using FACTS," *Indonesian Journal of Electrical Engineering and Computer Science (IJECS)*, vol. 22, no. 3. pp. 1223-1235, 2021, doi: 10.11591/ijeecs.v22.i3.pp1223-1235.
- [4] N. Pati, B. Panda, and B. Panda, "Stability analysis of photovoltaic system under grid faults," *International Journal of Power Electronics and Drive Systems (IJPEDS)*, vol. 11, no. 2. pp. 931-941, 2020, doi: 10.11591/ijpeds.v11.i2.pp931-941.
- [5] M. Q. Taha, "Advantages and recent advances of smart energy grid," *Bulletin of Electrical Engineering and Informatics (BEEI)*, vol. 9, no. 5. pp. 1739-1746, 2020, doi: 10.11591/eei.v9i5.2358.
- [6] B. Rajapandian and G. T. Sundarrajan, "Evaluation of dc-dc converter using renewable energy sources," *International Journal of Power Electronics and Drive Systems (IJPEDS)*, vol. 11, no. 4. pp. 1918-1925, 2020, doi: 10.11591/ijpeds.v11.i4.pp1918-1925.
- [7] M. A. A. Sufyan, M. Zuhair, and M. Rihan, "An investigation on the application and challenges for wide area monitoring and control in smart grid," *Bulletin of Electrical Engineering and Informatics (BEEI)*, vol. 10, no. 2, pp. 580-587, 2021, doi: 10.11591/eei.v10i2.2767.
- [8] P. Sharma, S. R. Salkuti, and S.-C. Kim, "Energy audit: Types, scope, methodology and report structure," *Indonesian Journal of Electrical Engineering and Computer Science (IJECS)*, vol. 22, no. 1. pp. 45-52, 2021, doi: 10.11591/ijeecs.v21.i4.pp45-52.
- [9] A. Lekbich, A. Belfqih, C. Zedak, J. Boukherouaa, and F. Elmariami, "Implementation of a decentralized real-time management system for electrical distribution networks using the internet of things in smart grids," *Bulletin of Electrical Engineering and Informatics (BEEI)*, vol. 10, no. 3, pp. 1142-1153, 2021, doi: 10.11591/eei.v10i3.2436.
- [10] P. K. Panda, A. Sahoo, A. Samal, D. P. Mishra, and S. R. Salkuti, "Voltage control of ac hybrid microgrid," *International Journal of Power Electronics and Drive Systems (IJPEDS)*, vol. 12, no. 2. pp. 793-802, 2021, doi: 10.11591/ijpeds.v12.i2.pp793-802.
- [11] H. Azoug, H. Belmili, and F. Bouazza, "Grid-connected control of pv-wind hybrid energy system," *International Journal of Power Electronics and Drive Systems (IJPEDS)*, vol. 12, no. 2. pp. 1228-1238, 2021, doi: 10.11591/ijpeds.v12.i2.pp1228-1238.

- [12] M. Datta, T. Senjyu, A. Yona, and T. Funabashi, "Photovoltaic output power fluctuations smoothing by selecting optimal capacity of battery for a photovoltaic-diesel hybrid system," *Electric Power Components and Systems*, vol. 39, no. 7, pp. 621–644, 2011, doi: 10.1080/15325008.2010.536809.
- [13] T. Rout, A. Chowdhury, M. K. Maharana, and S. Samal, "Analysis of energy management system for photovoltaic system with battery and supercapacitor using fuzzy logic controller," 2018 Technologies for Smart-City Energy Security and Power (ICSESP), no. 2, 2018, pp. 1-4, doi: 10.1109/ICSESP.2018.8376737.
- [14] S. R. Madeti and S. N. Singh, "Monitoring system for photovoltaic plants: A review," *Renewable and Sustainable Energy Reviews*, vol. 67, pp. 1180-1207, 2017, doi: 10.1016/j.rser.2016.09.088.
- [15] M. M. Abdullahi et al., "A review of building integrated photovoltaic: Case study of tropical climatic regions," *International Journal of Power Electronics and Drive Systems (IJPEDS)*, vol. 12, no. 1. pp. 474-488, 2021, doi: 10.11591/ijped.v12.i1.pp474-488.
- [16] M. M. Rahman, J. Selvaraj, N. A. Rahim, and M. Hasanuzzaman, "Global modern monitoring systems for PV based power generation: A review," *Renewable and Sustainable Energy Reviews*, vol. 82, Part 3, pp. 4142-4158, 2018, doi: 10.1016/j.rser.2017.10.111.
- [17] E. H. Chahid, M. I. Oumhand, M. Feddaoui, M. Erritali, and A. Malaoui, "Effect of measurement factors on photovoltaic cell parameters extracting," *International Journal of Electrical and Computer Engineering (IJECE)*, vol. 7, no. 1. pp. 50-57, 2017, doi: 10.11591/ijece.v7i1.pp50-57.
- [18] A. Halim, A. Fudholi, S. Phillips, and K. Sopian, "Review on optimised configuration of hybrid solar-PV diesel system for off-grid rural electrification," *International Journal of Power Electronics and Drive Systems (IJPEDS)*, vol. 9, no. 3. pp. 1374-1380, 2018, doi: 10.11591/ijped.v9n3.pp1374-1380.
- [19] O. A. Ahmad, H. Sayed, K. A. Jalal, D. Y. Mahmood, and W. H. Habeeb, "Design and implementation of an indoor solar emulator based low-cost autonomous data logger for PV system monitoring," *International Journal of Power Electronics and Drive Systems (IJPEDS)*, vol. 10, no. 3. pp. 1645-1654, 2019, doi: 10.11591/ijped.v10.i3.1645-1654.
- [20] A. A. Sneineh and W. A. Salah, "Design and implementation of an automatically aligned solar tracking system," *International Journal of Power Electronics and Drive Systems (IJPEDS)*, vol. 10, no. 4. pp. 2055-2064, 2019, doi: 10.11591/ijped.v10.i4.2055-2064.
- [21] A. Amir, A. Amir, H. S. Che, A. Elkhateb, and N. A. Rahim, "Comparative analysis of high voltage gain DC-DC converter topologies for photovoltaic systems," *Renewable Energy*, vol. 136, pp. 1147-1163, 2019, doi: 10.1016/j.renene.2018.09.089.
- [22] S. Gorai, D. Sattianadan, V. Shanmugasundaram, S. Vidyasagar, G. R. Prudhvi Kumar, and M. Sudhakaran, "Investigation of voltage regulation in grid connected PV system," *Indonesian Journal of Electrical Engineering and Computer Science (IJECS)*, vol. 19, no. 3. pp. 1131-1139, 2020, doi: 10.11591/ijeecs.v19.i3.pp1131-1139.
- [23] K. L. Shenoy, C. G. Nayak, and R. P. Mandi, "Effect of partial shading in grid connected solar pv system with fl controller," *International Journal of Power Electronics and Drive Systems (IJPEDS)*, vol. 12, no. 1. pp. 431-440, 2021, doi: 10.11591/ijped.v12.i1.pp431-440.
- [24] M. Torres, F. J. Muoz, J. V. Muoz, and C. Rus, "Online monitoring system for stand-alone photovoltaic applications-analysis of system performance from monitored data," *Journal of Solar Energy Engineering*, vol. 134, no. 3, pp. 1-8, 2012, doi: 10.1115/1.4005448.
- [25] S. Adhya, J. Das, A. Jana, and H. Saha, "An IoT Based Smart Solar Photovoltaic Remote Monitoring and Control unit," 2016 2nd International Conference on Control, Instrumentation, Energy & Communication (CIEC), 2016, pp. 432-436, doi: 10.1109/CIEC.2016.7513793.
- [26] B. Khadidja, B. S. Amine, and B. Noureddine, "Control and supervision of a solar electric system," *International Journal of Power Electronics and Drive Systems (IJPEDS)*, vol. 10, no. 4, pp. 2096-2100, 2019, doi: 10.11591/ijped.v10.i4.2096-2100.
- [27] M. Z. M. Nasir, S. Salimin, B. Chan, and S. A. Jumaat, "Prototype development of smart parking system powered by solar photovoltaic," *Indonesian Journal of Electrical Engineering and Computer Science (IJECS)*, vol. 18, no. 3, pp. 1229-1235, 2020, doi: 10.11591/ijeecs.v18.i3.pp1229-1235.
- [28] S. Z. Islam, M. L. Othman, N. Mariun, H. Hizam, and N. Ayuni, "Feasibility analysis of standalone pv powered battery using SEN for smart grid," *International Journal of Power Electronics and Drive Systems (IJPEDS)*, vol. 11, no. 2, pp. 667-676, 2020, doi: 10.11591/ijped.v11.i2.pp667-676.
- [29] R. N. Hasanah, A. B. Setyawan, E. Maulana, T. Nurwati, and Taufik, "Computer-based solar tracking system for PV energy yield improvement," *International Journal of Power Electronics and Drive Systems (IJPEDS)*, vol. 11, no. 2, pp. 743-751, 2020, doi: 10.11591/ijped.v11.i2.pp743-751.
- [30] M. W. Hasan, "Covid-19 fever symptom detection based on IoT cloud," *International Journal of Electrical and Computer Engineering (IJECE)*, vol. 11, no. 2, pp. 1823-1829, 2021, doi: 10.11591/ijece.v11i2.pp1823-1829.
- [31] H. Ouldzira, A. Mouhsen, H. Lagraini, M. Chhiba, A. Tabyaoui, and S. Amrane, "Remote monitoring of an object using a wireless sensor network based on NODEMCU ESP8266," *Indonesian Journal of Electrical Engineering and Computer Science (IJECS)*, vol. 16, no. 3, pp. 1154-1162, 2019, doi: 10.11591/ijeecs.v16.i3.pp1154-1162.
- [32] Z. Dzulkurnain, A. K. Mahamad, S. Saon, M. A. Ahmadon, and S. Yamaguchi, "Internet of things (IoT) based traffic management & routing solution for parking space," *Indonesian Journal of Electrical Engineering and Computer Science (IJECS)*, vol. 15, no. 1, pp. 336-345, 2019, doi: 10.11591/ijeecs.v15.i1.pp336-345.
- [33] A. A. Jaber, F. K. I. Al-Mousawi, and H. S. Jasem, "Internet of things based industrial environment monitoring and control: A design approach," *International Journal of Electrical and Computer Engineering (IJECE)*, vol. 9, no. 6, pp. 4657-4667, 2019, doi: 10.11591/ijece.v9i6.pp4657-4667.

- [34] A. H. Ali, A. H. Duhis, N. A. Lafta Alzurfi, and M. J. Mnati, "Smart monitoring system for pressure regulator based on IOT," *International Journal of Electrical and Computer Engineering (IJECE)*, vol. 9, no. 5, pp. 3450-3456, 2019, doi: 10.11591/ijece.v9i5.pp3450-3456.
- [35] K. Luechaphonthara and A. Vijayalakshmi, "IOT based application for monitoring electricity power consumption in home appliances," *International Journal of Electrical and Computer Engineering (IJECE)*, vol. 9, no. 6, pp. 4988-4992, 2019, doi: 10.11591/ijece.v9i6.pp4988-4992.
- [36] M. S. A. Mahmud, S. Buyamin, M. M. Mokji, and M. S. Z. Abidin, "Internet of things based smart environmental monitoring for mushroom cultivation," *Indonesian Journal of Electrical Engineering and Computer Science (IJECS)*, vol. 10, no. 3, pp. 847-852, 2018, doi: 10.11591/ijeecs.v10.i3.pp847-852.
- [37] M. Niswar, M. Nur, A. A. Ilham, and I. Mappangara, "A low cost wearable medical device for vital signs monitoring in low-resource settings," *International Journal of Electrical and Computer Engineering (IJECE)*, vol. 9, no. 4, pp. 2321-2327, 2019, doi: 10.11591/ijece.v9i4.pp2321-2327.
- [38] H. S. Kim, J. S. Seo, and J. Seo, "A daily activity monitoring system for internet of things-assisted living in home area networks," *International Journal of Electrical and Computer Engineering (IJECE)*, vol. 6, no. 1, pp. 399-405, 2016, doi: 10.11591/ijece.v6i1.9339.
- [39] P. Veerakumar, "Energy monitoring system to display on web page using ESP8266," *Indonesian Journal of Electrical Engineering and Computer Science (IJECS)*, vol. 9, no. 2, pp. 286-288, 2018, doi: 10.11591/ijeecs.v9.i2.pp286-288.
- [40] R. S. Rosli, M. H. Habaebi, and P. R. Islam, "On the analysis of received signal strength indicator from ESP8266," *Bulletin of Electrical Engineering and Informatics (BEEI)*, vol. 8, no. 3, pp. 933-940, 2019, doi: 10.11591/eei.v8i3.1511.
- [41] M. A. A. Aziz, M. F. Abas, M. K. A. Abu Bashri, N. M. Saad, and M. H. Ariff, "Evaluating IoT based passive water catchment monitoring system data acquisition and analysis," *Bulletin of Electrical Engineering and Informatics (BEEI)*, vol. 8, no. 4, pp. 1373-1382, 2019, doi: 10.11591/eei.v8i4.1583.
- [42] A. M. A. Jalil, R. Mohamad, N. M. Anas, M. Kassim, and S. I. Suliman, "Implementation of vehicle ventilation system using nodemcu ESP8266 for remote monitoring," *Bulletin of Electrical Engineering and Informatics (BEEI)*, vol. 10, no. 1, pp. 327-336, 2020, doi: 10.11591/eei.v10i1.2669.
- [43] A. S. Spanias, "Solar energy management as an Internet of Things (IoT) application," *2017 8th International Conference on Information, Intelligence, Systems & Applications (IISA)*, 2018, pp. 1-4, doi: 10.1109/IISA.2017.8316460.
- [44] M. Benganem and A. Maafi, "Data acquisition system for photovoltaic systems performance monitoring," *IEEE Transactions on Instrumentation and Measurement*, vol. 47, no. 1, pp. 30-33, 1998, doi: 10.1109/19.728784.
- [45] G. C. Ngo, J. K. I. Floriza, C. M. C. Creayla, F. C. C. Garcia, and E. Q. B. MacAbebe, "Real-time energy monitoring system for grid-tied Photovoltaic installations," *TENCON 2015 - 2015 IEEE Region 10 Conference*, 2016, pp. 1-4, doi: 10.1109/TENCON.2015.7372784.
- [46] R. I. S. Pereira, I. M. Dupont, P. C. M. Carvalho, and S. C. S. Jucá, "IoT embedded linux system based on Raspberry Pi applied to real-time cloud monitoring of a decentralized photovoltaic plant," *Measurement*, vol. 114, pp. 286-297, 2018, doi: 10.1016/j.measurement.2017.09.033.
- [47] Y. F. Li et al., "On-line monitoring system of PV array based on internet of things technology," *IOP Conference Series Earth and Environmental Science*, vol. 93, no. 1, 2017, Art. no. 012078, doi: 10.1088/1755-1315/93/1/012078.
- [48] U. Jan A. woyte M. R. D. M. S. M. Nils Reich, "Monitoring of photovoltaic System: Good practices and System Analysis," *Вестник Казнму*, vol. №3, p. 30, 2013.
- [49] H. Rezk, I. Tyukhov, M. Al-Dhaifallah, and A. Tikhonov, "Performance of data acquisition system for monitoring PV system parameters," *Measurement*, vol. 104, pp. 204-211, 2017, doi: 10.1016/j.measurement.2017.02.050.
- [50] B. Ando, S. Baglio, A. Pistorio, G. M. Tina, and C. Ventura, "Sentinella: Smart Monitoring of Photovoltaic Systems at Panel Level," *IEEE Transactions on Instrumentation and Measurement*, vol. 64, no. 8, pp. 2188-2199, 2015, doi: 10.1109/TIM.2014.2386931.
- [51] J. C. Franklin, M. Chandrasekar, and D. A. Mattius, "Development of Cost Effective Data Acquisition System to Evaluate the Performance of Solar Photovoltaic Thermal Systems," *Journal of Solar Energy Engineering*, vol. 143, no. 1, 2021, Art. no. 011003, doi: 10.1115/1.4047453.
- [52] A. Chouder, S. Silvestre, B. Taghezouit, and E. Karatepe, "Monitoring, modelling and simulation of PV systems using LabVIEW," *Solar Energy*, vol. 91, pp. 337-349, 2013, doi: 10.1016/j.solener.2012.09.016.
- [53] J. Han, I. Lee, and S. H. Kim, "User-friendly monitoring system for residential PV system based on low-cost power line communication," *IEEE Transactions on Consumer Electronics*, vol. 61, no. 2, pp. 175-180, 2015, doi: 10.1109/TCE.2015.7150571.
- [54] Y. Cheddadi, H. Cheddadi, F. Cheddadi, F. Errahimi, and N. Es-sbai, "Design and implementation of an intelligent low - cost IoT solution for energy monitoring of photovoltaic stations," *SN Applied Sciences*, vol. 2, 2020, Art. no. 1165, doi: 10.1007/s42452-020-2997-4.
- [55] A. Lopez-Vargas, M. Fuentes, and M. Vivar, "IoT Application for Real-Time Monitoring of Solar Home Systems Based on ArduinoTM with 3G Connectivity," *IEEE Sensors Journal*, vol. 19, no. 2, pp. 679-691, 2019, doi: 10.1109/JSEN.2018.2876635.
- [56] M. Benganem, "Measurement of meteorological data based on wireless data acquisition system monitoring," *Applied Energy*, vol. 86, no. 12, pp. 2651-2660, 2009, doi: 10.1016/j.apenergy.2009.03.026.