

## FEASIBILITY STUDY ON THE FUSION OF PHITS SIMULATIONS AND THE DLNN ALGORITHM FOR A NEW QUANTITATIVE METHOD OF *IN-SITU* MULTIPLE-CHANNEL DEPTH DISTRIBUTION SPECTROMETRY

M. Sakama<sup>1\*</sup>, K. Fujimoto<sup>2</sup>, K. Inoue<sup>3</sup>, M. Fukushi<sup>3</sup>, Y. Imajyo<sup>4</sup>, T. Fukuhara<sup>4</sup>, M. Matsuura<sup>5</sup>, T. Yajima<sup>4</sup>, M. Endo<sup>4</sup>, M. Fujisawa<sup>3</sup>, and E. Matsumoto-Kawaguchi<sup>1</sup>

<sup>1</sup>Department of Radiation Science and Technology, Division of Radiological Sciences, Institute of Biomedical Sciences, Tokushima University, Kuramoto-cho 3-18-15 Tokushima 770-8509, Japan, <sup>2</sup>Faculty of Engineering and Design, Kagawa University, Hayashi-cho 2217-20, Takamatsu City, Kagawa 761-0396, Japan, <sup>3</sup>Graduate School of Human Health Sciences, Tokyo Metropolitan University, Higashi-Ogu 7-2-10, Arakawa City, Tokyo 116-8551, Japan, <sup>4</sup>Advanced Fusion Technology (AFT), Co.,Ltd., Sotokanda 5-6-3, Chiyoda-ku, Tokyo 101-0021, Japan, <sup>5</sup>CLEAR-PULSE, Co.,Ltd., Chuo 6-25-17, Ota-ku, Tokyo 143-0024, Japan

Received on 27 September, 2018, revised on 16 January, 2019, accepted on XXXX XX, 2019

We have recently have developed an *in-situ* multiple-channel depth distribution spectrometer (DDS) that can easily acquire on-site measurements of the depth distribution of specific radioactivities of Cs-134 and Cs-137 underground. Despite considerable improvements in the hardware developed for this device, the quantitative method for determining of radioactivities with this DDS device cannot yet achieve satisfactory performance for practical use. For example, this method cannot discriminate each  $\gamma$ -ray spectra of Cs-134 and Cs-137 acquired by the 20 thallium-doped caesium iodide CsI(Tl) scintillation crystal detectors of the DDS device from corresponding depth levels of underground soil. Therefore, we have applied deep learning neural network (DLNN) as a novel radiation measurement technique to discriminate the spectra and to determine the specific radioactivities of Cs-134 and Cs-137. We have developed model soil layers on a virtual space in Monte-Carlo based PHITS simulations and transported  $\gamma$ -ray radiation generated from a particular single soil layer or multiple layers as radiation sources; next, we performed PHITS calculations of those specific radioactivity measurements for each soil layer using DDS device based on machine learning via the DLNN algorithm. In this study, we obtained informative results regarding the feasibility of the proposal innovative radiation measurement method for further practical use in on-site applications.

### INTRODUCTION

In 2011, the Fukushima Dai-ichi Nuclear Power Plant (FDNPP) released large amount of particulates including radionuclides of I-131, Cs-134 and Cs-137, which contaminated residential areas and agricultural fields [1]. Even now more than seven years later, air dose rates (which relate the ambient dose to the measurable dose) in most contaminated areas have not yet returned to dose level values that were measured prior to the accident that occurred on 11 March 2011 because of long half-lives of caesium radionuclides, despite measures taken by the Japanese government to decontaminate these areas [2]. Currently, radioactive caesium nuclides continue to deposit on the surface of contaminated grounds; in particular, this trend is more apparent at the difficult-to-return zone at Fukushima and at the FDNPP. It is likely that the released caesium radionuclides deposit on the ground and then dissolve in the ground. In this way, the caesium radionuclides are strongly bound to the layered structure of clayey soil in accordance with the characteristic properties of caesium, exhibiting a-quasi-potassium behaviour.

Therefore, the development of novel on-site specific radiation measurement tools such as the *in-situ* multiple-channel depth distribution spectrometer (DDS) [3] has received attention from public administrations and local governments to establish future decontamination policies. Moreover, radioecology researchers applied environmental modelling to investigate the nature of the association of soil-bound caesium and the long-term mechanisms of underground radionuclide distribution and migration.

The objective of this experiment was to study the feasibility of an *in-situ* multiple-channel DDS for commercialisation in the near future. We have developed a DDS radiation measurement system to precisely and easily determine the specific radioactivities of caesium radionuclides Cs-134 and Cs-137 and the naturally occurring nuclides for each targeted underground layer along with depth direction using the DDS device. Our innovative quantitative analytical method for determining specific radioactivity (i.e., Bq/kg) is presented using Monte-Carlo based PHITS calculations combined with a deep learning neural network (DLNN) algorithm.

\*Corresponding author: [minorusakama@tokushima-u.ac.jp](mailto:minorusakama@tokushima-u.ac.jp)

## MATERIALS AND METHODS

Figure 1 shows our developed radiation measurement system, termed a DDS device, which is in the preliminary stage of production. This DDS device

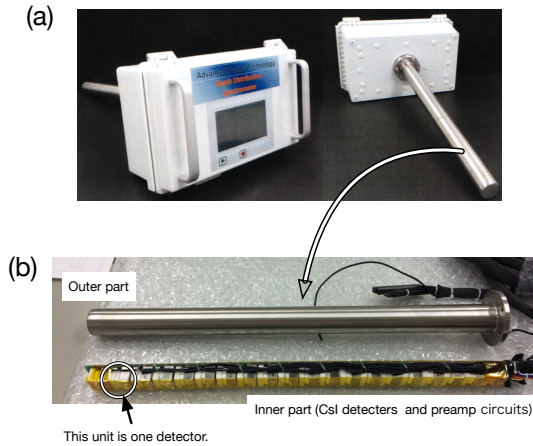

Figure 1. (a) Photograph of *in-situ* multiple-channel DDS (AFT-DDS) produced via Advanced Fusion Technology (AFT), Co., Ltd. (b) Photograph of the detector assay of this device, in which an inner assay of 20 CsI(Tl) scintillation crystal detectors and their preamp circuits are located in parallel with the outer region composed of an SUS-304 stainless steel canal.

system consists of two units; an SUS-304 stainless steel canal (as one unit, with an external diameter  $\phi$  of 30 mm and a canal length of 421 mm) equipped with 20 CsI(Tl) scintillation crystal detectors (crystal volume of  $10 \times 10 \times 10 \text{ mm}^3$ ; another type of DDS device with 10 detectors can also be optionally selected) and a box unit (as one unit, with dimensions of  $270 \times 170 \times 110.5 \text{ mm}^3$ ) with an LED touch panel that can display and store the  $\gamma$ -ray spectra acquired from the 20 detectors in real time. The CsI(Tl) scintillation crystal in each detector is equipped with a large-area PIN-photodiode, provided by HAMAMATSU<sup>TM</sup>, in which electric charge collection-type preamplifier and a 35-V bias supply circuit are embedded. As shown in Fig. 1, two cable assembly configuration groups are assembled into electrical wiring bundles for the even- and odd-numbered CsI(Tl) detectors with wires on both sides of the detectors and a single row lining the canal.

In this study, the quantitative specific radioactivity (Bq/kg) of the soil layer corresponding to each detector is determined from the gamma-ray spectra acquired by the DDS device via our innovative radiation analysis method, which is presented using the Monte-Carlo-based PHITS calculations combined with the DLNN algorithm of MATLAB<sup>TM</sup> (MathWorks, Inc.). An engineering schematic of the DDS device is obtained

using the 3D IronCAD software to reproduce the  $\gamma$ -ray radiation transport in the PHITS code with high precision. The obtained 3D CAD data are automatically converted into a geometrically defined input description of PHITS using the SuperMC/MCAM [4] software produced by the Institute of Nuclear Energy Safety Technology, Chinese Academy of Sciences.

Currently the PHITS code [5, 6] is updated by a research group for radiation transport analysis of JAEA (Japan Atomic Energy Agency) through a collaboration of well-known institutes in Japan and Europe. The Monte-Carlo-based calculation method including the PHITS code is one of various radiation transport analysis methods employed in radiation science; this approach can accurately reproduce the transport of nearly all radiation and particles, including neutrons, protons, heavy ions, photons, positrons and electrons, over a wide range of energy levels using various nuclear reaction models and nuclear and atomic data libraries based on nuclear and radiation physical phenomena. The latest version (3.05) of the PHITS code was released in March 2018 and was thus available for implementation of the  $\gamma$ -ray radiation distribution and transport simulations in this study.

We utilized the DLNN algorithm based on a stacked auto-encoder in the Neural Network Toolbox<sup>TM</sup> of MATLAB<sup>TM</sup> to learn and analyse the quantitative features of a large number of  $\gamma$ -ray spectra as the DDS output data of response characteristic calculated by the PHITS simulation code. Figure 2 displays a block diagram of the stacked auto-encoder network coupled to a hierarchical neural network, which is related to a feedforward neural network. As shown in this figure,

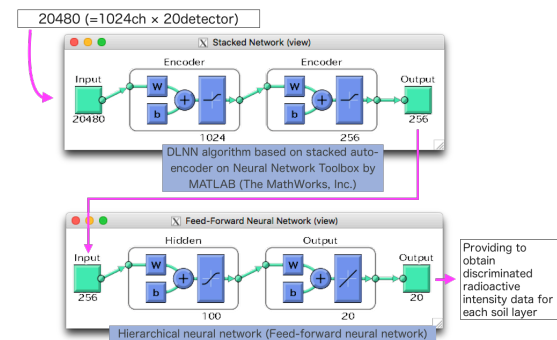

Figure 2. Block diagram of a stacked auto-encoder network coupled to a hierarchical neural network, which is related to a feedforward neural network, using the Neural Network Toolbox<sup>TM</sup> from MATLAB<sup>TM</sup>.

using the DLNN algorithm, we obtain 20-channel data from the initial data for 20480 channels, thus confirming that the use of 20 CsI(Tl) scintillation detectors enabled us to discriminate spectra from various soil layers.

A soil layer comprised of either homogeneous or heterogeneous material is employed for the PHITS-defined source section. The shape of the soil layer is a cylinder with a radius of 25 cm. Next, the primary radiation is generated, and the PHITS calculation is initiated. Secondary radiation is generated by interactions among the primary radiation, and it is detected by CsI(Tl) scintillation detectors; then, the characteristic response spectra of those detectors are combined with the depth direction beneath the surface. For the geometry and material settings in the PHITS simulation, including parameters for the DDS device and simplified model soil layers a cylindrical shape with a radius of 25 cm is used in this feasibility study, as well as a stainless canal unit with a length of 421 mm protruding from the box unit of the DDS device, which is buried into the model soil underground. The entire canal unit is completely buried under the model soil. As the external diameter of the canal is 30 mm, the size of the hole opening to the soil surface is 50 mm  $\phi$  inner diameter; this geometry condition matches the actual and experimental on-site conditions encountered in actual contamination areas. The elements comprising the model soil in the PHITS calculation include Al, Si, O, H, K, Na, Ca and Mg, which are input into the parameter section of the PHITS code; these elements closely match the constituent elements of actual soil in the study area, and the input soil density ( $1.86 \text{ g/cm}^3$ ) is equivalent to that of the actual soil on site.

The characteristic response data for a detector response function, as shown in Fig. 3, are presented for the training and analysis of fundamental data via machine learning with the present DLNN algorithm. Suitable input parameters are encoded as defined tally sections of the PHITS in order to reproduce the response characteristics of the CsI(Tl) detectors in the DDS device. Using the radiation technique coupled with the DLNN algorithm, our preliminary results indicate the possibility of discriminating one to three continuous layers of simulated soil based on radiation sources with initial radioactivities of 5, 10 and 15 MBq for Cs-134 and Cs-137; thus these intensities are employed as machine learning data for the DLNN algorithm. As described above, we have investigated whether these data enable discrimination via the DLNN algorithm for the DDS device to identify specific soil layer positions based on the radiation sources in PHITS simulations; we then assessed whether this method can determine the radioactivity of each CsI(Tl) detector and consequently the soil layers corresponding to the radiation sources using 20 raw  $\gamma$ -ray spectra simultaneously.

## RESULTS AND DISCUSSION

A conventional method [2, 7] has been employed to prepare numerous soil layer samples with exclusive vessels such as U-8 containers, and the radioactivities of Cs-134 and Cs-137 at each soil layer were

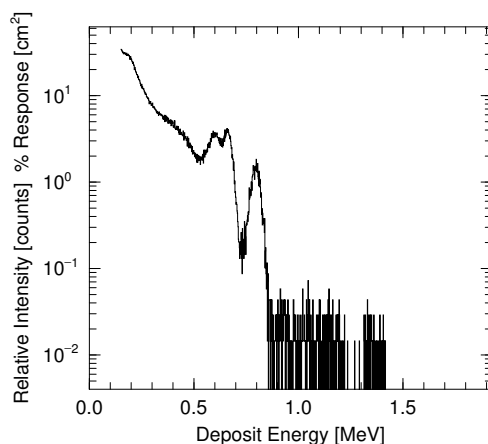

Figure 3. Calculated PHITS spectrum for a sample detector response function (with intensity = 1.0) relative to the response characteristics of a CsI(Tl) detector for the DDS device. The y-label 'Response' denotes the tally output of PHITS code points, which is equivalent to the relative intensity [counts], and the x-label 'Deposit Energy [MeV]' is equivalent to the  $\gamma$ -ray energies measured by CsI(Tl) detector.

individually determined off-site using a high-purity germanium detector. However, a long duration is required before the radiation measurement can be performed, and the sample pre-treatment is complicated; moreover, transportation of the samples is difficult. Having determined that the developed method cannot distinguish the specific radioactivities in a depth radiation distribution for the soil layers of interest, we have presented a novel radiation measurement technique that incorporates the DLNN algorithm, which is superior to the conventional methods, with the following advantages.

- Radiation measurement is easier.
- The need to dig soil for core samples is eliminated.
- Transportation of the soil core samples is unnecessary.
- Due to the high mobility of this method, data points can be acquired for numerous sampling locations at one time.

As an example, the geometry and track tally results from the PHITS simulation are shown in Fig. 4. This track distribution of radiation primarily represents photons and electrons. The radiation originates from radioactive caesium nuclides of Cs-134 and Cs-137 decaying into only the first layer of the model soil with the PHITS radiation source parameters.

Figures 5 shows three examples of DLNN learning result data for initial radioactivities of  $I = 10$  and 15 MBq for three soil position settings #7 for one radioactive source layer, #15 and #16 for two continuous layers and #4, #5 and #6 for three continuous layers. The images on the left side of figures 5(a), (b) and

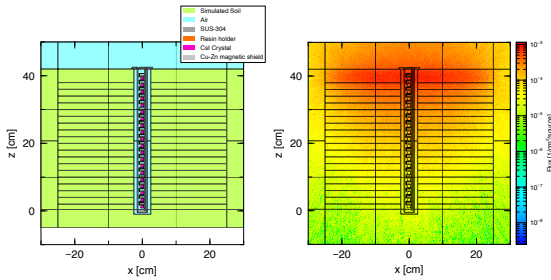

Figure 4. Geometry (left) and track tally results (right) of PHITS simulations performed for the radiation distribution measured by DDS device.

(c) present histograms of gross photon counts stored by the PHITS-calculated response function spectra for the 20 CsI(Tl) detectors of the DDS device. The images on right side present the results obtained by the DLNN algorithm in MATLAB; in this work, the algorithm has identified positions of radioactive sources as well as the corresponding radioactive intensities. It should be noted that the gross number of photons for the detector closest to the input radioactive source layer reaches a maximum; as the position moves from the nearest detector, the number of photons gradually decreases. Thus, for several continuous radioactive sources, it can be concluded that the photon counts emitted from the adjacent soil layers are summed in the corresponding spectra. However, using the DLNN algorithm in MATLAB we can identify unknown radioactive positions and also determine the corresponding specific radioactivities. Repetitive training was implemented for the DLNN algorithm to obtain accurate results for the 20 CsI(Tl) detectors in the PHITS calculation. Using location of a radiation source and that of two or three continuous sources in each soil layer as learning data for the DLNN, an accuracy of 99.94% was achieved by applying the presented method. If, for each of the DLNN outputs in the soil layers corresponding to the radiation sources, we assume a specific inaccuracy of  $\pm 20\%$  in the radiation intensity while the values for the other soil layers are accurate, then we can conclude that the present learning results are correct. Based on the DLNN calculation conditions, we have obtained an accuracy rate of 74.56% several times during the DLNN learning trials. Thus, from the present feasibility study, it can be concluded that the accuracy rate is improved by establishing detailed PHITS calculation settings that match actual experimental conditions.

CONCLUSION

In this study, it has been demonstrated that a depth distribution profile for specific radioactivities of underground Cs-134 and Cs-137 measured by the DDS

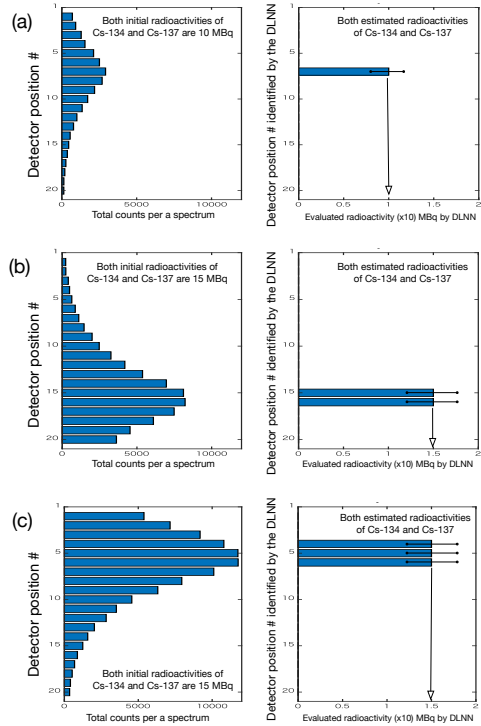

Figure 5. Three examples of DLNN learning results for initial radioactive intensities of  $I = 10$  and  $15$  MBq at three soil position settings: #7 for one radioactive source layer, #15 and #16 for two continuous layers and #4, #5 and #6 for three continuous layers.

device can be estimated using the PHITS calculation code combined with the DLNN algorithm of MATLAB with the option for a stacked auto-encoder in the Neural Network Toolbox. We assumed that this novel quantitative radiation method incorporating the DLNN algorithm will aid future predictions of actual radiation experiments as well as the practical applications.

ACKNOWLEDGEMENT

This work was supported by the Environment Research and Technology Development Fund of the Environmental Restoration and Conservation Agency under grant number 1RF-1602.

REFERENCES

- Adachi K, Kajino M, Zaizen Y, and Igarashi Y (2013) Emission of spherical cesium-bearing particles from an early stage of the Fukushima nuclear accident. Scientific Reports 3(2554):1–5

*SHORT TITLE*

2. Chernobyl forum expert group for environment (2006) Environmental consequences of the Chernobyl accident and their remediation: twenty years of experience, Report of the Chernobyl forum expert group for environment. International Atomic Energy Agency (IAEA), Radiological assessment reports series
3. Hamada K (2016) Depth distribution measurement device of radioactive intensity in soil. *Isotope News* 4(744):15–17
4. Y. Wu and FDS Team (2009) CAD-based interface programs for fusion neutron transport simulation. *Fusion Engineering and Design* 84:1987–1992
5. Sato T, Niita K, Matsuda N, Hashimoto S, Iwamoto Y, Noda S, Ogawa T, Iwase H, Nakashima H, Fukaori T, Okumura K, Kai T, Chiba S, Furuta T, and Sihver L (2013) Particle and Heavy Ion Transport code System, PHITS, version 2.52. *Journal of Nuclear Science and Technology* 50(9):913–923
6. Sato T, Niita K, Matsuda N, Hashimoto S, Iwamoto Y, Furuta T, Noda S, Ogawa T, Iwase H, Nakashima H, Fukaori T, Okumura K, Kai T, Chiba S, and Sihver L (2015) Overview of particle and heavy ion transport code system PHITS. *Annals of Nuclear Energy* 82:110–115
7. Matsuda N, Mikami S, Shimoura S, Takahashi J, Nakano M, Shimada K, Uno K, Hagiwara S, and Saito K (2015) Depth profiles of radioactive cesium in soil using a scraper plate over a wide area surrounding the Fukushima Dai-ichi Nuclear Power Plant, Japan. *Journal of Environmental Radioactivity* 139:427–434