

Old Dominion University

ODU Digital Commons

Mechanical & Aerospace Engineering Theses & Dissertations

Mechanical & Aerospace Engineering

Spring 2021

A Model-Based Systems Engineering Approach to e-VTOL Aircraft and Airspace Infrastructure Design for Urban Air Mobility

Heidi Selina Glauzel

Old Dominion University, hsgnova@gmail.com

Follow this and additional works at: https://digitalcommons.odu.edu/mae_etds



Part of the [Mechanical Engineering Commons](#), and the [Systems Engineering and Multidisciplinary Design Optimization Commons](#)

Recommended Citation

Glauzel, Heidi S.. "A Model-Based Systems Engineering Approach to e-VTOL Aircraft and Airspace Infrastructure Design for Urban Air Mobility" (2021). Master of Science (MS), Thesis, Mechanical & Aerospace Engineering, Old Dominion University, DOI: 10.25777/4y6k-9c02
https://digitalcommons.odu.edu/mae_etds/333

This Thesis is brought to you for free and open access by the Mechanical & Aerospace Engineering at ODU Digital Commons. It has been accepted for inclusion in Mechanical & Aerospace Engineering Theses & Dissertations by an authorized administrator of ODU Digital Commons. For more information, please contact digitalcommons@odu.edu.

**A Model-Based Systems Engineering Approach to e-VTOL Aircraft and Airspace
Infrastructure Design for Urban Air Mobility**

By: Heidi Selina Glaudel
B.S.A.E. May 2007, Embry-Riddle Aeronautical University

A Thesis Submitted to the Faculty of
Old Dominion University in Partial Fulfillment of the
Requirements for the Degree of

MASTER OF SCIENCE

Batten College of Engineering and Technology
Mechanical and Aerospace Engineering Department
Old Dominion University
May 2021

Approved By:

Dr. Sharan Asundi (Director)
Dr. Oktay Baysal (Member)
Dr. Holly Handley (Member)
Dr. Miltiadis Kotinis (Member)

A Model-Based Systems Engineering Approach to e-VTOL Aircraft and Airspace Infrastructure Design for Urban Air Mobility

Heidi S. Glaudel
Old Dominion University
Student Master's Thesis
May 2021

Abstract

This paper serves to contribute to Model-Based Systems Engineering (MBSE) by following the NASA Systems Engineering Handbook framework for a Systems Engineering (SE) design approach to an Electric Vertical Takeoff and Landing (e-VTOL) aircraft and the incorporating airspace infrastructure. The focus of this study is, by using the MBSE model created, to capture the technical requirements definition and design intent of the vehicle and airspace inclusive of community specific knowledge derived from the Federal Aviation Administration (FAA) NextGen Urban Air Mobility (UAM) Concept of Operations (ConOps) version 1.0. The stakeholder requirements derived from the FAA UAM NextGen ConOps will form the bedrock for the aircraft infrastructure requirements from which the flight mission requirements are derived. From these requirements, the profile of a notional flight mission is provided. Additionally, from the flight mission requirements, a design solution can be proposed and examined to ensure it meets the original stakeholder needs. The vehicle and associated airspace environment are modeled using an MBSE dedicated platform, Cameo Systems Modeler, in a language called SysML. The resulting MBSE model created can demonstrate the traceability between top-level system requirements down to the subcomponent-level design. In the conclusive study of the sub-system behavioral relationships, the analysis and validation of the proposed design solution can support model reliability.

Copyright, 2020, by Heidi Selina Glaudel, All Rights Reserved.

ACKNOWLEDGMENTS

Many people have contributed and aided in the successful completion of this thesis. I would like to extend a special thanks to my advisor Dr. Sharan Asundi for his continuous guidance, support, and countless efforts to make this thesis a possibility. I would also like to extend gratitude for my professional colleagues John Gregory, Christopher Wolfsmith, Andrea Morris, Ary Glantz, and James Winsley for assisting with the review of my designs and critical engineering input. I would like to personally thank Dr. Miltiadis Kotinis, Dr. Holly Handley, and Dr. Oktay Baysal for their willingness to review my thesis and participate in the defense. I would additionally like to extend gratitude to Neil O'Connor, Rania Ghatas, Annie Cheng, and Savita Verma for being a part of my review process.

Nomenclature

<i>ACT</i>	Activity Diagram
<i>API</i>	Application Program Interface
<i>ARMED</i>	Aeronautics Research Mission Directorate
<i>BDD</i>	Block Definition Diagram
<i>CAD</i>	Computer-Aided Design
<i>ConOps</i>	Concept of Operations
<i>CPU</i>	Central Processing Unit
<i>e-VTOL</i>	Electric Vertical and Takeoff Landing
<i>ETOPS</i>	Extended Operations Certification
<i>DFD</i>	Data Flow Diagram
<i>DEP</i>	Distributed Electric Propulsion
<i>EFFBD</i>	Enhanced Functional Flow Block Diagram
<i>FAA</i>	Federal Aviation Administration
<i>FARs</i>	Federal Aviation Regulations
<i>FFBD</i>	Functional Flow Block Diagram
<i>HUD</i>	Heads-Up Display
<i>IBD</i>	Internal Block Diagram
<i>ICAO</i>	International Civil Aviation Organization
<i>IFR</i>	Instrument Flight Rules
<i>IEC</i>	International Electromechanical Commission
<i>INCOSE</i>	International Council on Systems Engineering
<i>ISO</i>	International Organization for Standardization

<i>JAA</i> s	Joint Aviation Agencies
<i>KDP</i> s	Key Decision Points
<i>MBSE</i>	Model-Based Systems Engineering
<i>MoE</i>	Measure of Effectiveness
<i>NAS</i>	National Airspace System
<i>NASA</i>	National Aeronautics and Space Administration
<i>NC</i>	National Campaign (formerly known as the Grand Challenge)
<i>NMI</i>	Nautical Miles
<i>OMG</i>	Object Management Group
<i>PAX</i>	Passengers
<i>PDU</i>	Power Distribution Unit
<i>PIC</i>	Pilot in Command
<i>PP&C</i>	Project Planning and Control
<i>PSU</i>	Provider of Services
<i>SARPS</i>	Standards and Recommended Practices
<i>SD</i>	Sequence Diagram
<i>SE</i>	Systems Engineering
<i>STM</i>	State Machine Diagram
<i>SADT</i>	Structured Analysis and Design Technique
<i>SysML</i>	Systems Modeling Language
<i>UAM</i>	Urban Air Mobility
<i>UAS</i>	Unmanned Aerial System
<i>UC</i>	Use Case Diagram

<i>UML</i>	Unified Modeling Language
<i>UML</i>	UAM Maturity Level
<i>UOE</i>	UAM Operational Environment
<i>USS</i>	UAS Service Suppler
<i>UTM</i>	UAS Traffic Management
<i>VFR</i>	Visual Flight Rules
<i>VTOL</i>	Vertical and Takeoff Landing

TABLE OF CONTENTS

	Page
LIST OF TABLES.....	xi
LIST OF EQUATIONS.....	xi
LIST OF FIGURES	xii
Chapter	
1. INTRODUCTION	1
1.1 BACKGROUND ON URBAN AIR MOBILITY.....	1
1.2 HISTORY OF URBAN AIR MOBILITY OPERATIONS.....	3
1.3 CURRENT UAM AIRCRAFT DESIGNS IN DEVELOPMENT.....	6
1.4 CURRENT E-VTOL DESIGN LIMITATIONS	8
1.5 NEED FOR SYSTEMS ENGINEERING CONCEPTS FOR MBSE	11
1.6 PROBLEM STATEMENT	18
1.7 THESIS FRAMEWORK	19
2. BACKGROUND: MODEL-BASED SYSTEMS ENGINEERING METHODOLOGY	21
2.1 OVERVIEW OF MODEL-BASED SYSTEMS ENGINEERING	21
2.2 BACKGROUND ON SYSML AND THE FOUR PILLARS	23
2.3 ADOPTING THE NASA FRAMEWORK FOR A SYSTEMS ENGINEERING PROCESS	25
2.4 MBSE of E-VTOL METHODOLOGY.....	27
3. CONSTRUCTION OF THE E-VTOL MBSE MODEL	30
3.1 STAKEHOLDER EXPECTATIONS AND REQUIREMENTS MODELING	30

3.2 PROPOSED LEVEL 1 FLIGHT MISSION REQUIREMENTS FOR ANALYSIS	35
3.3 FLIGHT MISSION ENVIRONMENT AND CONCEPT OF OPERATIONS...	37
3.4 DEFINING LOGICAL ARCHITECTURE	39
3.5 MODEL ORGANIZATION AND CONTAINMENT TREE	40
3.6 USE CASE MODELING	45
3.7 BEHAVIOR MODELING	46
3.8 STRUCTURE MODELING.....	55
3.9 PARAMETRIC MODELING.....	67
4.0 ANALYSIS: ANALYZING THE SYSML MODEL	71
4.1 SYSML MODEL ANALYSIS	71
4.1.1 MBSE APPROCH TO COMPLETELY ELECTRIC E-VTOL FEASIBILITY.....	71
4.1.2 TECHNICAL DECISION ANALYSIS FOR A PROPOSED DESIGN SOLUTION.....	74
4.1.3 SATISFYING UAM OPERATOR OPERATIONAL REQUIREMENT...77	
4.2 MODELING OFF-NOMINAL FLIGHT SCENARIOS USING BEHAVIOR MODELING	82
5.0 CONCLUSION.....	85
5.1 THESIS DELIVERABLE SUMMARY AND CONCLUSION.....	85
6.0 WORKS CITED	88
7.0 APPENDIX A: THE “V” SYSTEMS ENGINEERING MODEL.....	94
8.0 VITA.....	95

----- **This page is intentionally left blank** -----

LIST OF TABLES

Table	Page
1.0: UAM Aircraft Currently Under Development.....	8
2.0: Popular Software Used for Aircraft Design.....	16

LIST OF EQUATIONS

Equation	Page
1.0.....	57
2.0.....	57
3.0.....	71
4.0.....	71

LIST OF FIGURES

Figure	Page
1.0: Urban Air Mobility Concept of Operations.....	2
2.0: Curtiss-Wright Aerial Jeep (VZ-7) – Circa 1958.....	4
3.0: On-Demand Helicopter Transport Using Airbus’ Voom Aircraft.....	5
4.0: Wingless Multirotor E-VTOL: Volocopter 2X.....	6
5.0: Aurora-Boeing Passenger Air Vehicle Design.....	7
6.0: Joby S2 Tilt-Propeller Design.....	7
7.0: Chemical Energy Content of Select Fuels (in MJ/kg)	10
8.0: Life Cycle Cost Impacts from Early Phase Decision Making.....	13
9.0: Document-Based Versus Model Based Systems Engineering.....	22
10.0: Breakdown of the SysML Diagrams.....	24
11.0: The System Engineering Engine (NPR 7123.1)	26
12.0: Inter-Relationships Amongst System Design Processes.....	29
13.0: Research Methodology “Roadmap”	29
14.0: Requirement Traceability from Stakeholder Needs.....	32
15.0: Stakeholder Needs for the UAM SysML model.....	33
16.0: UAM Operator Operational Requirements	34
17.0: Traceability of Flight Mission Requirements to Mission Objectives.....	34
18.0: Flight Path for e-VTOL Aircraft.....	37
19.0: Urban Air Mobility Corridor.....	38
20.0: Flight Mission ConOps.....	39
21.0: Plan the Modeling Effort Activity Diagram.....	40

22.0: Model Organization in the Containment Tree.....	41
23.0: Block Definition Diagram of the Mission Context	42
24.0: Package Diagram of the Model Organization.....	44
25.0: Basic Flight Mission Use Case Diagram.....	46
26.0: Activity Diagram of “Performing Flight Mission”	47
27.0: Activity Diagram of “Perform Vertical Takeoff”	48
28.0: UAM Activity Diagram with Component Swim Lanes	49
29.0: Activity Diagram for Atlantic City Flight Mission.....	50
30.0: Activity Diagram for a UAM Flight Operation.....	51
31.0: Sequence Diagram for a Flight Mission Request.....	52
32.0: State Machine Diagram of Aircraft Flight Behavior.....	53
33.0: Block Definition Diagram for Perform Mission Failure Modes.....	54
34.0: Concept Vehicle Graphic of the Mistral Air Taxi.....	55
35.0: Lilium Jet 5-Seater Aircraft.....	55
36.0: Composition of Weight Categories.....	59
37.0: Typical Payload and Range Diagram.....	59
38.0: MEW Systems Requirements in Relation to a Mission Objective	60
39.0: Block Definition Diagram of UAM Vehicle System.....	61
40.0: Block Definition Diagram of the Main Structural Body.....	62
41.0: Block Definition Diagram of the Fuselage System.....	63
42.0: Block Definition Diagram of the Propulsion System.....	64
43.0: Internal Block Diagram of the UAM Vehicle System Interfaces	65
44.0: Comprehensive Subsystems Schematic.....	66

45.0: Internal Block Diagram of the Propulsion System.....	67
46.0: Detailed Schematic of Propulsion System Proposed.....	67
47.0: Parametric Diagram of Electrical to Propulsion Connection.....	68
48.0: Traceability of a Subsystems Requirement to the Requirement Authority.....	70
49.0: Feasibility of an All-Electric Design through MBSE.....	74
50.0: Design Solution Study Conducted for UAM Configuration.....	76
51.0: Requirements Diagram for Refined Mission Requirements Part 1.....	79
52.0: Requirements Diagram for Refined Mission Requirements Part 2.....	79
53.0: Mission Requirements to Stakeholder Needs “Derive Requirement” Matrix.....	80
54.0: Artifacts Versus Milestones Requirement Matrix.....	81
55.0: SysML Diagram of the Verification Domain.....	82
56.0: Vertiport Re-route Off-Nominal Scenario Diagram.....	83
57.0: Activity Diagram for Vertiport Re-route Off-Nominal Scenario.....	84
A1.0: Traditional SE “V” Diagram in Relation to a MBSE UAM Vehicle Project.....	94

CHAPTER 1 – INTRODUCTION

With the growing rate of technological expansion in the field of Urban Air Mobility (UAM), it becomes important to focus on methodologies to help develop these concept aircraft designs that will one day be introduced into the National Airspace System (NAS). Since many of these aircraft are still in the testing/demonstration stage as prototypes, this is a good opportunity to look at engineering approaches that would assist in these efforts. Systems engineering is shifting towards a more model-centric approach to design where the model configuration is managed in the virtual environment entirely through Model-Based Systems Engineering (MBSE). An MBSE approach could prove quite useful in the preliminary stages of electric Vertical Takeoff and Landing (e-VTOL) aircraft and airspace development when stakeholder requirements and design intent are still developing. Design configuration changes may stem from top-level requirement changes resulting from changes in the flight mission or from off-nominal scenarios that require a design update.

1.1 BACKGROUND ON URBAN AIR MOBILITY

The notion to perform UAM operations in the form of air taxis to transport passengers has been prevalent since the 1940s and is gaining popularity again due to congestion in urban areas. [3] As the tempo for usage of VTOL/e-VTOL grows due to inherent desire to mitigate ground transportation density, a set of technological and operational challenges must be overcome to see a true concept of operations fully realized. In São Paulo, Brazil and Mexico City, Mexico, urban air transport via helicopters is already an integrated reality but is associated with a steep financial cost. [3] Studies have also indicated a push away from helicopter transport due to community

noise complaints and limited passenger capacity. In Dubai and the United Arab Emirates, prototypes for air taxi infrastructure are in development. [3] Major stakeholders in the UAM community are the Federal Aviation Administration (FAA), the National Aeronautics and Space Administration (NASA), the U.S. Department of Transportation, General Aviation Manufacturers Association, transportation researchers, academic institutions, municipal governments, and civil aviation authorities. [4] From these key players, conceptual development of a UAS (Unmanned Aerial System) Traffic Management system (UTM) is in the preliminary stages that is currently used as medical transports, package delivery, and weather observational data and would need to be developed for passenger transport. Figure 1.0 depicts a conceptual illustration of UAM operations.



Figure 1.0: Urban Air Mobility Concept of Operations [3]

In the United States alone, corporate players such as aircraft manufacturers like Bell Helicopters, Airbus, and Boeing, ridesharing company Uber, and startups such as Kitty Hawk's Cora have taken serious interest in this commercial potential. [4] Along that wavelength, Uber Elevate is already conducting on-demand helicopter operations in New York City, NY. As the

commercial market landscape keeps opening, so arises the need to adopt a procedural directive to integrate and carefully monitor these aircraft during flight operations. Safely integrating these UAM aircraft into the NAS is of the highest priority. NASA's original research in UAM came from the over-arching framework of On-Demand Mobility (ODM), which focuses on the flight operations between a takeoff-site to any location without the schedule delays seen in current commercial transport. As a subgroup of ODM, UAM strictly examines the metropolitan airspace ecosystem for passenger transport of distances up to 100 nautical miles (nmi) or less. [3] As an effort to help promote public confidence in UAM and help accelerate UAM operations in the NAS, NASA's Aeronautics Research Mission Directorate (ARMD) is hosting an Advanced Air Mobility "National Campaign" which includes industry partners demonstrating aspects of actual flight missions. [5] These mission demonstrations include simulated aircraft contingency management, advanced two-way network communications, and visual obstruction avoidance handling. It is also a desire for these industry partners to assist in developing maturity levels, what are termed as UAM Maturity Levels (UML). [5] The higher the UML, the denser and more complex the airspace and operations become. In conjunction to hosting the National Campaign, NASA is working jointly with the FAA to develop the FAA NextGen ConOps to help provide direction to this emerging technology.

1.2 HISTORY OF URBAN AIR MOBILITY OPERATIONS

As previously mentioned, urban air transport has been a part of the airspace infrastructure since World War II and became more popular in the 1950s with helicopter operations. The operational intent is similar to that of helicopter operations but the design intent behind a UAM vehicle differs in that there is a market need for a "greener" design philosophy and the need for

noise reduction. [6] After World War II, the commercial use of helicopters integrated into many roles, including firefighting, police work, agricultural crop spraying, mosquito control, medical evacuation, and carrying mail and passengers. [6] Figure 2.0 depicts an early aerial military UAM vehicle. Certain configurations of the multirotor design, which is discussed in this paper, resembles this early depiction of an “aerial jeep” shown in Figure 2.0.

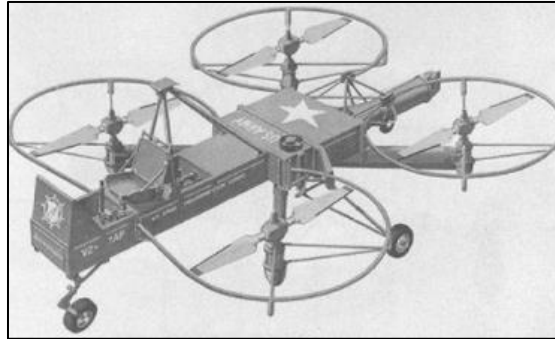

Figure 2.0: Curtiss-Wright Aerial Jeep (VZ-7) – Circa 1958 [7]

By the 1960s, urban public living reached a space age of new ideas ranging from monorails to modular housing. By the 1980s, most urban VTOL services, including in the San Francisco Bay Area, were out of business, due to the following reasons: noise pollution, danger inherent in operations, and expensive costs. [8] From the 1940s – 1970s, both Los Angeles Airways and New York Airways conducted helicopter flights to transport passengers from major airport terminal areas to different locations within those metropolitan areas. [3] In that timeframe, both airways experienced a series of tragic accidents, which led to crippling financial consequences and complete termination of operations. Currently, companies such as Airbus’ Voom and BLADE Bounce have taken over a majority of these intercity on-demand helicopter operations. [3] Figure 3.0 depicts Airbus’ VOOM Aircraft transporting a passenger in current state operations and uniquely identifies how urban air travel is currently a reality via VTOL/helicopter

aircraft, but this is not a mainstream mode of travel due to the high expense associated with it, which can be construed from the figure.



Figure 3.0: On-Demand Helicopter Transport Using Airbus' Voom Aircraft [9]

The shift between use of helicopter to UAM vehicles for ODM is due to community-based regulations requiring a stricter requirement for noise reduction and engine output pollution. The aerospace industry's attitude is shifting towards a "greener" approach as fossil fuel consumption is a quarter already of a typical flight profile. For this reason, many aerospace manufacturing companies are investigating the usage of hybrid aircraft to satisfy the current need but steering towards all electric designs for the future. [10] Safety is also another factor for considering VTOL aircraft, as 45 percent of the total number of airplane accidents and fatalities occur during take-off and landing from 1959 through 2016. [11] In terms of current e-VTOL aircraft technology, a flight mission could be potentially limited on certain design characteristics such as battery capacity and weight loading. The need for a lightweight vehicle that can accommodate for the weight of passenger transport is inclusive of this industry research in these "novel" operations. Currently, technology forecasts that it will be another 5-10 years before e-VTOL aircraft can successfully perform these mission profiles [12]; however, that technology gap is rapidly closing.

1.3 CURRENT UAM AIRCRAFT DESIGNS IN DEVELOPMENT

To engage this emerging market for VTOL/e-VTOL aircraft to satisfy a need for rapid urban air travel, several companies have intensified the development of prototype aircraft. Future maturity models depict that these aircraft will eventually become autonomous, but early stages will have a pilot onboard being directed by conventional air traffic management personnel. [12] Currently on the market, three configurations of UAM aircraft are leading the stage. These configurations are the multi-rotor design (wingless), the lift and cruise design, and the vectored thrust design. [13]

The multi-rotor design, as depicted in Figure 4.0, offers a unique advantage in that it has a faster certification time but has the disadvantage of having a shorter flight range and a reduced speed; hence making this aircraft suitable for short range city operations. Wingless e-VTOL are multirotor aircraft. The E-Hang 184 and the Volocopter 2X are already in the certification phase. Hoverbikes are considered a subset of multirotors and are usually characterized by a single seat where the rider sits on a saddle or stands up while in flight. [13]



Figure 4.0: Wingless Multirotor E-VTOL: Volocopter 2X [13]

The lift and cruise e-VTOL design is popular since it can demonstrate a wider flight range and speed than the multicopter design. Some configurations have a wing incorporated in the design for efficient cruise. Similar to the vectored thrust e-VTOL design, they have two different propulsion systems for hover and cruise flight. The Aurora Flight Sciences Passenger Air Vehicle (PAV) e-VTOL design, as depicted in Figure 5.0, and the Kitty Hawk Cora design are examples of lift and cruise designs. [13]



Figure 5.0: Aurora-Boeing Passenger Air Vehicle (PAV) Design [14]

The vectored thrust design, shown in Figure 6.0, offers the greatest average in-flight speed over the other two designs, as the same propulsion system is used for both hover and cruise. [13] However, these designs have a longer certification process. The operative difference in this type of design is whether the design has fans or propellers.



Figure 6.0: Joby S2 Tilt-Propeller Design [13]

Table 1.0 depicts some of the most current projects for e-VTOL in development. No concept vehicle of an e-VTOL design in the U.S. has been commercialized yet. [12]

Table 1.0: UAM Aircraft Currently Under Development [15]

Vehicle Name	Company	Passengers	Status
Joby S4 e-VTOL	Joby Aviation	5	airframe certification process
Lilium jet	Lilium GmbH	2 (expected 5)	early-stage hover and maneuvering tests
Skai air taxi	Alakai Skai	5	liquid hydrogen powertrain development
Volocopter 2X	Volocopter	2 to 5	completed demonstration flights
216 autonomous air taxi	eHang	2	demonstration flights
DreamMaker	Embraer	4 (+1 pilot)	under development
Aurora Passenger Air Vehicle (PAV)	Aurora (Boeing)	2	undergoing test flights
ROSA/gyrodyne design	Jaunt Air Mobility	5	under development
KittyHawk	Cora	2	undergoing test flights
A3 Vahana	Airbus	2	discontinued
CityAirbus	Airbus Helicopter	4	technology validation platform testing
FanCRAFT	Urban Aeronautics	6	hydrogen fuel cell powertrain development
10-Rotor Multicopter	Hoversurf	2 to 6	plans for larger VTOL ducted fans
Nexus 4EX	Bell Flight	6	investigating multiple powertrain options
S-A1	Hyundai	5	full-sized model displays
Butterfly	Karem Aircraft	5	under development
801 e-VTOL air taxi	Pipistrel Vertical Solutions	5	under development

1.4 CURRENT E-VTOL DESIGN LIMITATIONS

Currently, there are several issues, which present a challenge for e-VTOL aircraft from integrating into the modern airspace. Lithium-ion batteries hold the strongest candidacy for this emerging e-VTOL market due to specific energy output. [16] However, battery capacity limitations comprise a large percentage of the problem at hand. Battery capacity output is determined by the battery mass, type, and volume the given battery. The current state of Lithium-ion battery pack-level specific energy is around 150 Wh/kg, although by predicting an increase by 300 Wh/kg would extend the range of the aircraft (Note: Lithium-ion batteries are the focused

technology in this discussion as they hold the strongest capability of fulfilling future needs). An additional requirement that battery capacity relies on is maximum takeoff weight. [16] If the flight needed to carry more than one person under the current state of pack-level specific energy output, the flight range requirements could not be met. [16] Figure 7.0 depicts a graph of the chemical energy content of certain fuels. Shown in Figure 7.0, the energy content of lithium-ion batteries is orders of magnitude smaller than kerosene or hydrogen in MJ/kg. This emphasizes the challenges ahead for eVTOL development. [17] Ergo, most if not all prototypes may need to rely on hybrid hydrocarbon fuel designs for sustained flight.

In general, multiple motors and propellers (or ducted fans) are incorporated into the design of these vehicles to overcome shortcomings, a design strategy known as Distributed Electric Propulsion, or DEP. [18] Distributed electric propulsion systems utilize electrically driven propulsors, which are only connected electrically to energy sources or power-generating devices. [18] There are additional technology limitations; rendering an entirely electric vehicle not feasible at the moment, which pose other issues as well. For one, there are technology gaps which prohibit the new standards of noise reduction. The noise of an e-VTOL is postulated to be below 67 dB at 250 feet above ground level according to UBER Elevate, 2016. [19] This is not possible with today's helicopter technology unless the engine is converted to fully electric and the rotor blades diameters are designed smaller. [19] Outside of limitations in battery technology and noise requirements, certification, urban infrastructure development, emissions signature reduction, vehicle performance optimization, pilot training, public confidence, and safety pose as other notable hurdles in the race for urban on-demand mobility. [19] To secure public trust that this venture will be a success, safety must be at the forefront. At today's airspace standards, at 10^{-9} reliability [20], which would mean that in a model that had a fleet size of a 1000 aircraft and

1000 flight hours in one year [20], statistically one failure would occur every year. At the projection of the UAM stakeholder business forecast, imagine now there are 50,000 aircraft at 3000 flight hours [20] each annually to assess probability of an accident. This would exponentially increase the probability for an accident. Additionally, as stakeholder business models not only increase the volume of flights but traditionally cater to low operating costs. Part of the stride to reduce operating costs, is to run autonomous e-VTOL operations with pilots flying these aircraft from the ground remotely. To secure the public trust that these operations will be operated with reduced risk, several safety demonstrations and flight tests will be needed.

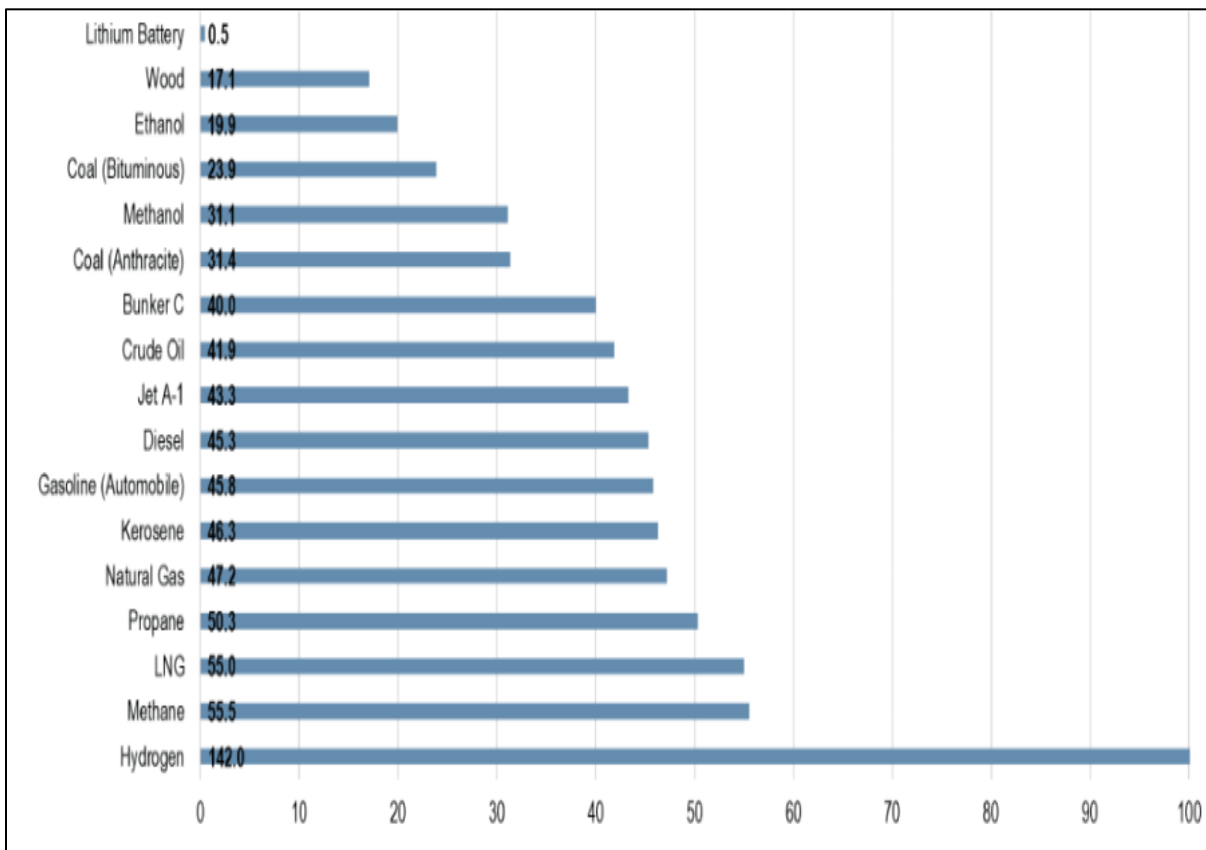

Figure 7.0: Chemical Energy Content of Select Fuels (in MJ/kg) [17]

1.5 NEED FOR SYSTEMS ENGINEERING CONCEPTS FOR MBSE

Any aircraft in production will create the need for regulatory and operational certification requirements. In the United States, the institution of traditional aircraft certification/requirements falls under the regulatory authority of the Federal Aviation Administration (FAA). While the manufacturing of UAM vehicles is still in the prototype development phase, the FAA is working on airworthiness certification requirements for these newly emerging aircraft. Per reference [21], it is presumed that an e-VTOL vehicle will fall under the following for airworthiness certification:

1. FAR Part 21.17 (b) [21]
 - 1a. Part 23 for a normal category aircraft with special conditions [21]
 - 1b. Part 27 for a normal category rotorcraft with special conditions [21]
2. Any number of less popular certification paths [21]

If the flight operation has the intent to carry passengers, this is termed as a “novel” operation. [21] The FAA is still developing guidance for paths to certification for “novel” operations. If a UAM vehicle in such a “novel” operation were to use Part 23 as a starting point (which is encompassed in FAR 21.17 (b)), it would fall under a prime example of the limitations of a document-traced aviation set of regulations. On March 9, 2016, the FAA released a notice to update the airworthiness certification requirements for aircraft that fell under the 14 CFR Part 23 certification process with a revision now known as the Part 23 rewrite. This discussion regarding the Part 23 rewrite is emphasized over the other Parts that fall under FAR 21.17(b) due to the scope of the amendments needed.

In reference [22], this life-cycle study addresses several key issues, which lead to recommendations to update this set of requirements included in Part 23. For example, Part 23 differentiates requirements based on engine type and on airplane weight. [22] Additionally, this

did not include operational intent of the aircraft as a factor in the certification requirements. In the Part 23 life-cycle study, an amendment was also needed to account for a hierarchy of maintenance data. [22] Another factor contributing to the Part 23 rewrite concerned the design certification, where there were challenges in meeting procedural requirements for type certifications of aircraft. This posed an undue burden for those manufacturing the aircraft. In many aircraft manufacturing companies, there is an in-house compliance engineering team to translate these types of requirements for the engineering management team to ensure compliance. Select companies have an option delegation authority (ODA) in which this compliance team is certified by the FAA to act as their representative. The translation of requirements is traditionally document-based. Accompanying each aircraft build is a certification “package”, typically managed by compliance engineers.

Utilization of MBSE (where MBSE infers use of MBSE dedicated software) in managing those requirements is a direct functionality of management’s interest in that expenditure for that additional software resource. Currently, SE conceptual modeling is done more often without the use of actual MBSE. This is unfortunate, as MBSE can help in tracing requirements and additionally assist in modeling the operational intent of the vehicle (behavior modeling). MBSE implementation can also prove useful when Tier 3 requirements become Tier 1 requirements, when the work shifts over from the main contractor to the subcontractor level.

Another area where MBSE could be of use is in the topic of continued airworthiness. During the aircraft’s life cycle, there are FAA-mandated forms that must be filled out to be process compliant when certain situations occur. An example of this, FAA Form 337 for Major Repair and Alteration [23] is filled out by an engineer or technician. MBSE modeling would allow this input to become a data requirement as part of a larger MBSE model, thus allowing the

process to drive the forms in aircraft manufacturing, and not the other way around. Equipping companies with MBSE capability could streamline requirement situational awareness. An example would be where subcontractor technical leads could invoke a needed change in a continued application of an original designed structural requirement that was potentially problematic. This can then lead to cost analysis efforts, which can reduce manufacturing over-expenditure. It can easily be demonstrated that MBSE can be proven useful in isolating possible design defects early in the design phase. In a real-world context, if not identified early, these design flaws could cost considerably more in the development and sustainment phase of these aircraft. This is evident in Figure 8.0, taken from the Defense Acquisition University. [1]

Depending on how the system is designed, this will set the cost matriculation throughout the lifecycle. Also, of note in this figure is the design change cost as you move further towards the sustainment phase. Therefore, it is important to perform periodic testing and analysis earlier than the verification and validation stages. [1]

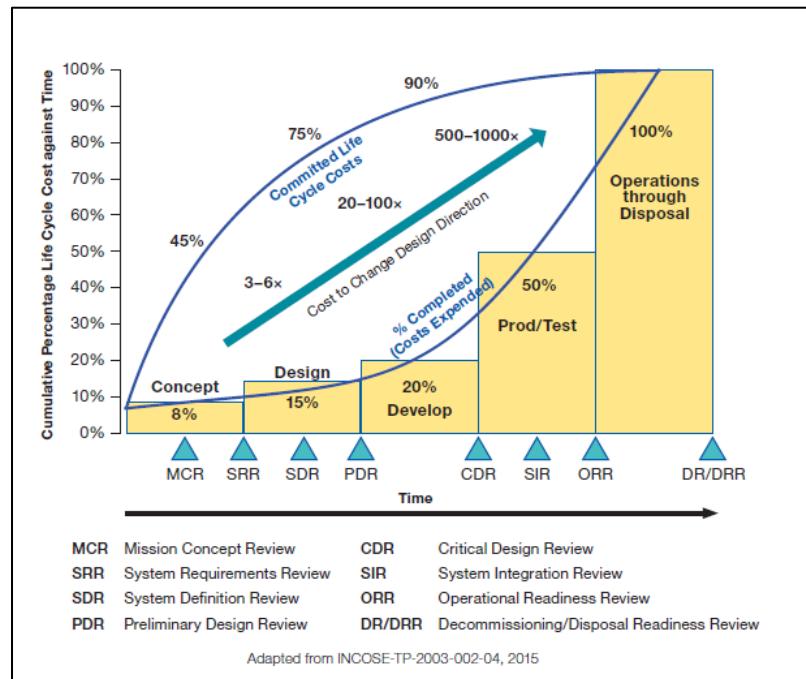

Figure 8.0: Life Cycle Cost Impacts from Early Phase Decision Making [1]

Additionally, MBSE creates an environment perfect for stakeholders and team members across industry to collaborate on the prospective design and have a greater grasp on the design domain. Another important advantage is that the MBSE approach helps facilitate reuse of designs. In the emerging market of e-VTOL design, this could prove very useful since many of the UAM flight mission requirements are similar. Proven concept configuration designs could be re-used to meet industry requirements versus the extra expense incurred in creating new designs and accompanying analyses. Additionally, at the beginning of any project, MBSE could benefit the entire project by capturing stakeholder artifacts early on and aid in scoping the project deliverables.

As it is apparent there is a direct need for MBSE to be integrated in the process of requirement mapping, it is also clearly evident there are specific research gaps that exist in other areas concerning design origination. There are several research papers and articles that address the topics in the areas of MBSE, aircraft detail design, and urban air mobility aircraft. However, there are very few research efforts transcribed on open-source media that exist currently that encompass all three of these aspects. Additionally, many research efforts do not even employ the basic fundamentals of systems engineering in their design process, let alone use software modeling techniques. This could be due to the fact that the procedural definition for urban air mobility environment is still being currently defined by the FAA/NASA (as the first revision for Urban Air Mobility Concept of Operations first appeared in June of 2020), so the operational intent of these vehicles is still under development.

To meet the current stringent design requirements needed to make these VTOL/e-VTOL designs a reality, high-fidelity software is being employed to create these configurations in a virtual environment first. In most cases, several different platforms are used simultaneously to understand not only the geometry of the design, but also the multibody dynamics, nonlinear finite elements, structural dynamics, and rotorcraft aerodynamics. However, it can be noted for

the research herein discussed in this section, that no systems engineering conceptual work or modeling was mentioned in the fundamental design origination process. Systems analysis is a component of NDARC; however, it is not the focus in the following papers listed. [24] In the study presented in “*VTOL Urban Air Mobility Concept Vehicles for Technology Development*” [25] and “*Concept Vehicles for VTOL Air Taxi Operations*” [26], a multitude of different software is utilized to complete the research. In that study, NASA Design and Analysis of Rotorcraft (NDARC) is used as the primary sizing and performance analysis tool, while OpenVSP is used in parallel to create the geometry and CAMRAD II for the surrogate model generation and rotor design. [25] [26] NDARC is a conceptual design environment capable of representing e-VTOL aircraft through semi-parametric and parametric modeling. The sizing is prepared by consecutive substitutions in the software. New design performance is calculated based on calibrations against similar aircraft models.

In a similar study presented in “*Current Capabilities and Challenges of NDARC and SAUVE for e-VTOL Aircraft Design and Analysis*” [27], the Kitty Hawk Cora e-VTOL design is the focal point for a comparative analysis. The author outlines how two design environments, NDARC and SAUVE, are both employed to investigate aircraft properties such as vehicle weight and aircraft performance based on the same mission profile. Again, there is no mention of systems engineering concepts in the design process for this research. Based on the report, the results concluded that the SAUVE analysis model leaned favorably towards a more structurally efficient design versus an aerodynamic one, whereas as the NDARC model catered more towards an aerodynamic design. [27]

Systems Modeling Language, SysML, a language used for MBSE modeling, can do more than just capture design intent. In an MBSE platform, such as Cameo Systems Modeler, the

technical requirements definition, the design intent, and the verification of the proposed design through analysis can streamline the whole project. [28] If an MBSE framework were to be fully utilized in conjunction with aircraft design development efforts, using a SysML based modeling, better design coordination could result. This does not mean to say that MBSE software can eradicate the need for using specific design software; in fact, it cannot, but more so compliment the design process. Table 2.0 depicts relevant software used for current UAM Aircraft design that could be used to compliment any MBSE related project.

Table 2.0: Popular Software Used for UAM Aircraft Design

Popular Aircraft Design CAD Platforms	
Aeronautics Specific Software	Other Software Used
SharkCAD Pro	CATIA
ADS (Aircraft Design Software)	Solidworks
Cart3D	Pro/Engineer (PTC Creo)
OpenVSP	Inventor
	NX
	Solid Edge
	SktechUp
Popular Aircraft Design Environments for e-VTOL Aircraft Design	
SUAVE	
NDARC	
COMRAD II	

In reference “*Conceptual Design and Mission Analysis for eVTOL Urban Air Mobility Flight Vehicle Configurations*”, five different configurations of UAM aircraft are discussed for suitability for a pre-specified flight mission using VSPAERO to perform the aerodynamic calculations. [29] This optimization study examines the aircraft from a weights-based optimization approach and lists several other criteria for selecting the most suitable aircraft to perform the mission. The suitability selection also notionally operates in a domain of both mission range and speed in the analysis. [29] As aforementioned, there is no systems engineering conceptual modeling in determining the initial design proposals. There is also no hierarchy of requirements needed for the aircraft selected in this basic mission outlined. The only stated parameters were mission ranges (between 10-100 miles), operational ceiling, payload

requirement of 800 lbs., and a cruise speed range. By using requirements modeling typically used in SE research for these types of comparative studies, these constraints presented could be given a hierarchy level of importance; and certain designs would be the eliminated from the study earlier.

In another comparative design study summarized in “*A Performance Benchmark of Recent Personal Air Vehicle Concepts for Urban Air Mobility*”, two UAM aircraft configurations, an 18-rotor multicopter and a fixed wing lift and cruise, are scrutinized for sizing effects for three variations each of these two aircraft. [30] There is no explanation why these aircraft were selected, other than mention they were common aircraft used for UAM flights and some performance benefits. This study uses much published data in its research and could benefit much from a systems engineering logical ordering and mission requirement definition early in the process. The mission performance analysis is based on a five-segmented mission profile, with select design mission parameters weighted on a value scale. [30] Presented here is another opportunity where an MBSE modeling approach could be helpful in not only structuring a hierarchy for flight parameters but provide the traceability directly from the desired project artifacts to the performance metrics/ validation results at the end of the research. This would help organize the project as a whole product instead of segmented deliverable.

Another aspect that is missing from several literature sources is the implementation of systems engineering methods in modeling the airspace this type of aircraft will be conducting UAM operations. In reference, “*Proposed Approach to Studying Urban Air Mobility Missions Including an Initial Exploration of Mission Requirements*”; this illustrates the point aforementioned. In this paper, the researchers examine the operational conditions for UAM airspace using a “three-pronged approach” [31], with the first approach being operational

requirements definition which is to be used to elaborate on vehicle design (although vehicle design is not expounded upon in this paper). The paper goes on to examine initially a general UAM mission profile and then further details on three unique mission profiles, alternating parameters for payload and range. It is here, where MBSE modeling could be used to highlight the operational sequence of events through activity diagrams and other behavioral modeling for the three mission profiles specified. These instances serve as motivating examples as to why systems engineering stylized approach and MBSE modeling are important to include in any vehicle design efforts as well as airspace modeling.

1.6 PROBLEM STATEMENT

As the demand for faster intra-urban travel increases, so does the need for development of aircraft to address these demands. This market demand is driving the “need” to build UAM vehicles and begin design work to build these aircraft. As the push for “on-demand mobility” has intensified, designs are already underway from several different companies. However, our current industry practices do not leverage systems engineering methodologies or MBSE to the extent possible and as a consequence, mostly resort to a more document-centric engineering approach. In facing this current “state of operations” dilemma, the following questions are examined in this thesis research – (i.) can an MBSE approach to the design of an e-VTOL architecture and airspace demonstrate traceability of stakeholder requirements and track requirement changes to mature the modeled design intent, and (ii.) in implementing the MBSE framework for the vehicle architecture, can it be determined that a fully electric vehicle design is not feasible for current market needs based on technology limitations and a hybrid design could make a formidable design consideration.

1.7 THESIS FRAMEWORK

Chapter Two begins with the fundamentals and overview of MBSE and an introduction to SysML and the nine diagrams (used in this methodology) is discussed as well to compliment this understanding. This chapter also introduces the process adapted for the MBSE approach and examines the technical groundwork needed before setting up a model in referring back to the established NASA SE Handbook framework. The first outlined objective of this thesis is to build and analyze a MBSE reference model based on the SE process guidance of the NASA Systems Engineering Handbook (which cites information from NPR 7123.1, Systems Engineering Processes and Requirements [32]). This model will also “loosely” adapt to a lifecycle technical process similar to that of NPR 7120.5, NASA Space Flight Program and Project Management Requirements [33]. The research methodology, adapted from the NASA SE Handbook, serves as the “roadmap” for this paper and is discussed in Section 2.4. The actual need for an MBSE modeling approach is punctuated in Section 2.5.

Chapter Three begins the operation of constructing the actual reference model based on the knowledge provided in Chapter Two. This chapter begins the step-by-step modeling process by first capturing the stakeholder expectations and mission and system requirements needed for vehicle and airspace architecture and design. A discussion is presented in this chapter on the three levels of requirements used for model establishment. The notional flight mission requirements are presented in the following Section 3.2. These notional flight parameters (adapted from current published data) will facilitate in setting the stage for developing a set of vehicle system requirements. It will be supported that an MBSE approach provides early definition of system functional requirements, complete capture of the system activities, enhanced design integrity, better requirements traceability, improved detection of impact from requirement

changes, and a more versatile validation of these requirements. The research flight mission concept of operations is presented in Section 3.3. The preliminary vehicle architecture based on initial notional mission constraints will be used to build a technical decision analysis design study to later propose an initial design solution to be captured in the MBSE model. A demonstration of the capabilities of the nine diagrams in Cameo Systems Modeler is showcased using models from the actual MBSE model created for the UAM vehicle and the airspace environment.

Chapter Four analyzes the model connectivity and explores further topics in airspace infrastructure modeling. In this chapter, project artifact/requirement traceability and validation results are presented as well as some discussion on the relevance to this research. It is in this chapter where the full value of behavioral modeling of UAM operations in the corridor airspace can be examined; applicable not only in nominal operations but in off-nominal in-flight events as well.

Concluding remarks about the model and anticipated future work relevant to continuing this research is reviewed in Chapter Five.

CHAPTER 2 – BACKGROUND: MODEL-BASED SYSTEMS ENGINEERING METHODOLOGY

2.1 OVERVIEW OF MODEL-BASED SYSTEMS ENGINEERING

Model based systems engineering approaches systems development from the stance of an abstraction from reality to display the physical representation of the system through a series of models. These models help to establish a technical baseline to help contribute to the understanding of the system requirements, design, behavior analysis, and verification. Model-based engineering contrasts with the traditional document-centric approach and application in that it builds and manages the product in a virtual environment versus a paper-based one. [34] With the computer age emerging in the 1950s and 1960s, model-centric approaches were becoming more common, especially in control system and electrical engineering. However, Systems Engineering (SE) was still developing. The current SE standards are only ten years old [35], and still under development by the Standards Technical Committee of the International Council on Systems Engineering (INCOSE), subcommittee of the International Organization for Standardization (ISO), the International Electromechanical Commission (IEC), the Institute of Electrical and Electronics Engineers (IEEE), and the Object Management Group (OMG). [35] It is expected that there will be a massive paradigm shift in model-based designs over the course of the next decade. The system model is the main artifact of MBSE [28], containing a series of interconnected models following the similarity of a part tree in an assembly drawing. Model based system engineering practices demonstrate mastery of complex systems. A coherent model-based system will capture initial stakeholder requirements as the foundation of the model. From there detailed systems models deriving from these requirements must not only provide design

precision, but also allow collaboration amongst industry team members. Figure 9.0 shows an illustration of the document-centric approach converting to the model-based approach. Some advantages of using the MBSE approach are displayed in the list below: [28] [36]

1. Increased design and specification precision which yields less errors at later design phases
2. Optimal design integrity as evident in accurate traceability in system requirements, design, analysis, and verification information
3. Improved lifecycle maintenance of design baselines and system specifications
4. Provision of a virtual network that can be used as a collaboration tool amongst stakeholders and design/development team.

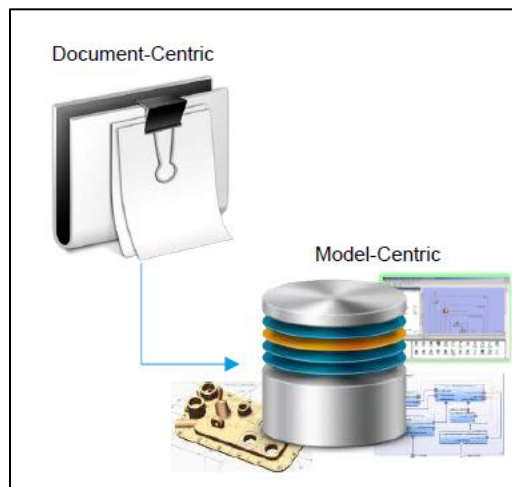

Figure 9.0: Document-Based Versus Model Based Systems Engineering [34]

The development process of the MBSE approach can be evaluated by the number of use cases that it produces, the number of requirements fulfilled, the successful connection of logical components to physical components, the interface specification comprehensiveness, the number of test cases, and the count of verification procedures that have been developed. The systems model is an “entity”. The “internal” system is defined by “states” and the outside of this system has valued inputs from where the system itself then derives its outputs. To summarize, MBSE

elevates the core engineering models to a central role where the models become the leading authority for design, integration, and specification of the entire system. [37]

2.2 BACKGROUND ON SYSML AND THE FOUR PILLARS

Back in the 1950s, systems engineering was starting to be represented by what is called Functional Flow Block Diagrams (FFBDs). Later in the 1970s, the Structured Analysis and Design Technique (SADT) evolved as the graphical language to communicate SE technology. [35] For data system flow, a Data Flow Diagram (DFD) is used. Although Enhanced FFBDs (EFFBDs) and the Integration Definition for Function Modeling (IDEF0) have been pervasive in the last couple of years, INCOSE and OMG (Object Management Group) jointly developed SysML which is a derivative off from the Unified Modeling Language (UML-not to be confused with UAM Maturity Level). [35] SysML is a graphical programming language used for representing systems models. Cameo Systems Modeler and MagicDraw are platforms (created by NoMagic (Dassault)) that use SysML to create these logical block diagrams to reveal the system as a whole and their interconnectivities. [28] These “blocks” can represent software, hardware, data, processes, personnel, and facilities. Unlike UML, which can use thirteen diagrams to decompose a system, SysML uses nine diagrams to represent different aspects of a system. [35] [28] Figure 10.0 shows the breakdown of all nine diagrams used in SysML. These nine diagrams assist in breaking down the four pillars of SysML, which are the requirements, the system structure, the system behavior, and parametric system relationships.

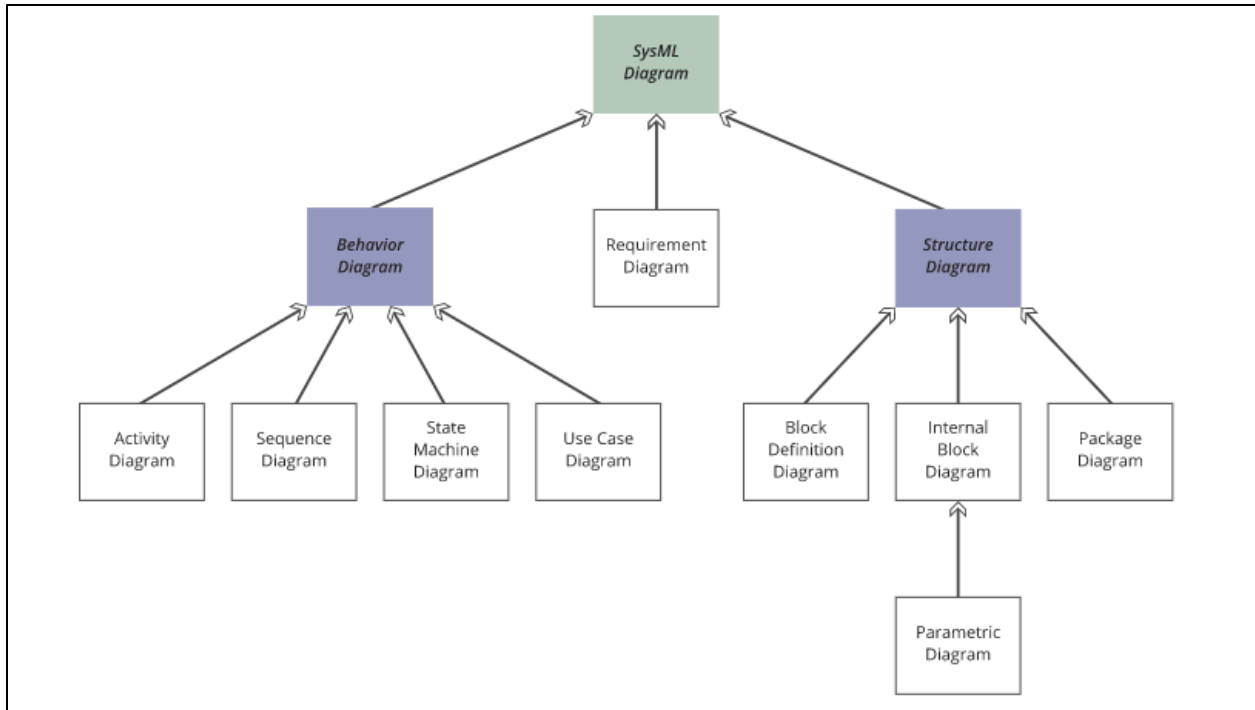

Figure 10.0: Breakdown of the SysML Diagrams [38]

At the beginning of any systems engineering model creation is the definition of requirements. The systems engineering “engine” uses these requirements to relay the needs of the stakeholders, as shown in Figure 11.0 (later in Section 2.3). These requirements can further be broken down as functional or technical requirements. The MBSE approach, using [1] as the framework, then creates dependency relationships with the stakeholder requirements and model elements such as the blocks, use cases, and test cases to establish model traceability. These relationships help define the system as a black box and can be represented as components of the requirement and in the requirement tables. Another important feature which manages the model organization is the package diagram. [28] The package diagrams help contain the model elements into logical folders. A good start for a systems model design would be to use the four pillars (requirements, structure, behavior, and parametrics) as the initial Package Diagrams. [28] Then, inside each of these package diagrams there would be nested packages to help decompose the multiple levels of

the design. Similar to a CAD assembly Part tree, the systems model is organized into a tree of packages. This “tree” is termed a containment tree.

2.3 ADOPTING THE NASA FRAMEWORK FOR A SYSTEMS ENGINEERING PROCESS

It is important for any systems engineering project work to be grounded in already existing guidelines that are well developed. For this effort, guidance on SE best practices were derived from the NASA Systems Engineering Handbook (NASA/SP-2016-6105 Revision 2) which frequently cites material from reference NPR 7123.1, Systems Engineering Processes and Requirements.

“Systems engineering” is defined as a methodical, multi-disciplinary approach for the design, realization, technical management, operations, and retirement of a system. [1] This methodology allows a bird’s eye view of the project artifacts to be managed and meet the stakeholder requirements in the intended use environment.

The three types of technical processes defined in Figure 11.0, “The Systems Engineering Engine”, are system design, product realization, and technical management. The process breakdown for each process is further decomposed. [1] It is anticipated that the designed solution will fulfill the original stakeholder expectations in the system design process. In the study presented in this paper, the stakeholder expectations definition becomes the Level 1 requirements from where the Level 2 system requirements come from. This is discussed later in the paper. The role of the technical management process is to culminate coordination amongst team authorities, develop technical plans spanning the project, to assess progress regarding requirements and plans, technical execution, and provide decision making. [1] Technical processes can be employed recursively and iteratively to break down established concepts of the system to a level

of discrete detail. The product realization process is applied to each project mission product starting with the lowest level product and working up to the higher-level products. It is through these processes that the design solution is achieved for each product.

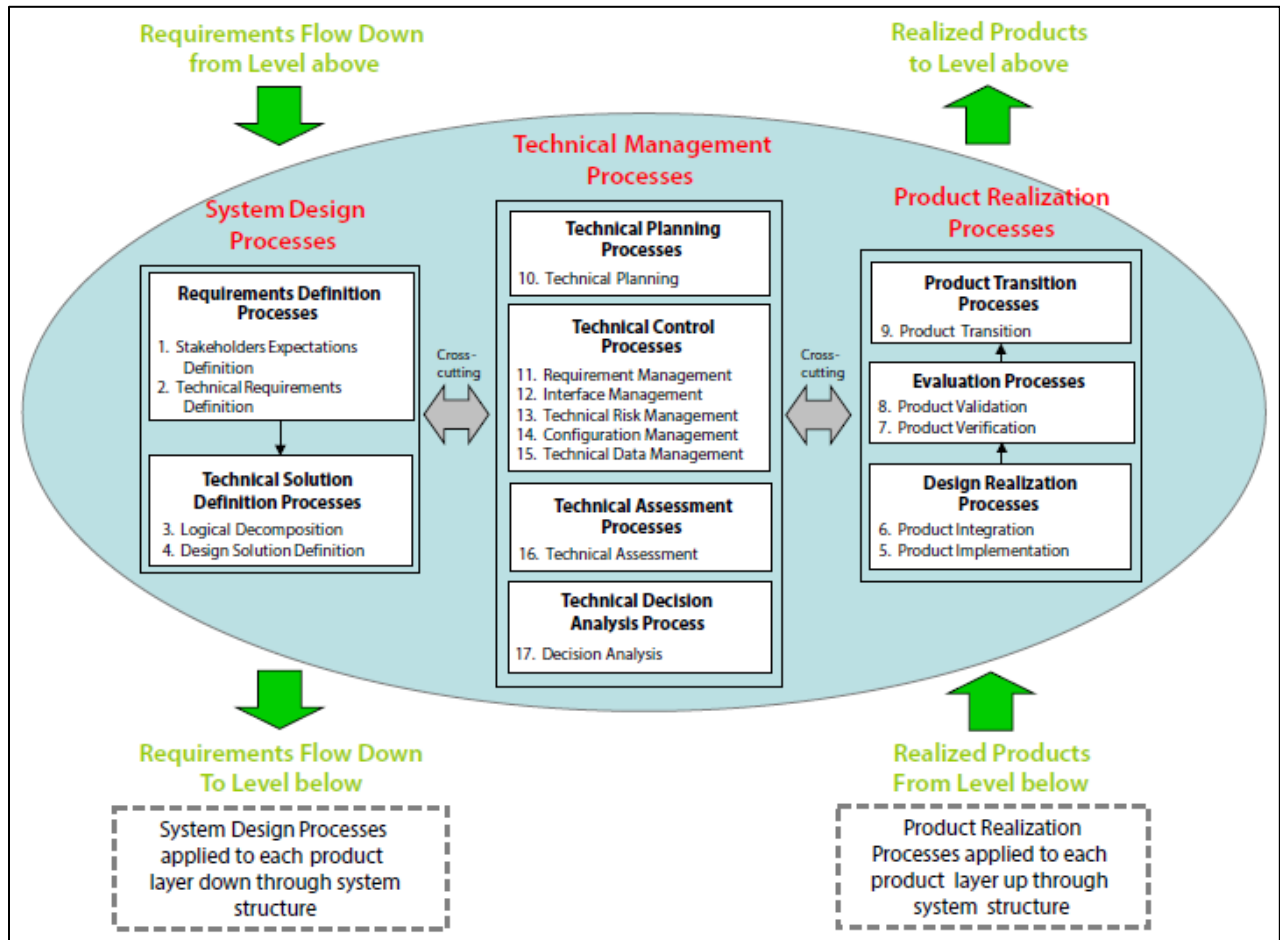

Figure 11.0: The System Engineering Engine (NPR 7123.1) [1]

Critical in managing core elements of any SE project is to govern those systems within the project through a program life cycle. A program lifecycle groups stages of the project into “phases” that are divided by “Key Decision Points” (KDPs). “KDPs are the events at which the decision authority determines the readiness of a program/project to progress to the next phase of the life cycle (or to the next KDP).” [1] Establishing project boundaries and greenlight decision points helps to frame the project into a more manageable entity.

For the SE project discussed in this paper, the project lifecycle as referenced in NASA procedure NPR 7120.5, NASA Space Flight Program and Project Management Requirements [33], would be the most suitable to selectively adapt to, with some additional considerations that this paper discusses a project involving UAM vehicle and airspace procedural development versus a project dealing with spacecraft launch operations.

The NASA SE Handbook describes its Program/Project Life Cycles by referring to the lifecycle phases as defined in NPR 7120.5. These phases are the Formulation Phase and the Implementation Phase. [1][33] A list of the full lifecycle with all the phases is displayed in reference [1], however for the purpose of this research; a tailored life cycle will be followed, which will only focus on the Formulation Phase. For this research effort, the system design is the focus. Only “select” sub-processes categorized under Concept and Technology Development would be applicable for the design focus, which are referenced in [1].

As mentioned earlier, this research effort is “loosely” adapted to this life cycle process outlined in NPR 7120.5, as this structural architecture design in for an aircraft; so certain sub processes such as “develop initial orbital debris assessment” [1] would not be applicable for this effort. For an aircraft lifecycle development, process steps for market analysis and vehicle certification processes specific to the aviation industry would have to be included in a project of this magnitude to frame the work as congruent with real world practices. Market analysis can be used to generate economic requirements as well as customer requirements. [39]

2.4 MBSE of E-VTOL METHODOLOGY

When referring to the NASA Systems Engineering Handbook [1], Figure 12.0 below depicts Figure 4.0-1 on page 44 of [1], begins the process with the program authority defining

the stakeholder expectations. For the purposes of this research effort, the FAA UAM ConOps will serve in defining the stakeholder expectations and the notional flight mission parameters (built on published data) will establish the initial flight constraints. For the Requirements Definition block, the top-level requirements definition will be further defined in Section 3.1, which will be complemented by the information provided in Section 3.2. As Stakeholder Expectations and Requirements definition traditionally fall under Concept Studies as listed in reference [1], the next process step not shown in the picture (but inferred), is Concept and Technology Development. As Logical Decomposition was accomplished in this effort by MBSE software modeling, this will be further discussed in Chapter Three. In Section 3.8, a technical decision analysis is performed for several different configurations of UAM aircraft to assess what the performance metrics would be in response to the flight parameters proposed in Section 3.2. From this decision analysis (or trade study), an optimal configuration was chosen to then serve as an initial design solution. Figure 13.0 depicts a diagram, which shows the actual work performed in this paper in relation to the original “roadmap” in Figure 12.0.

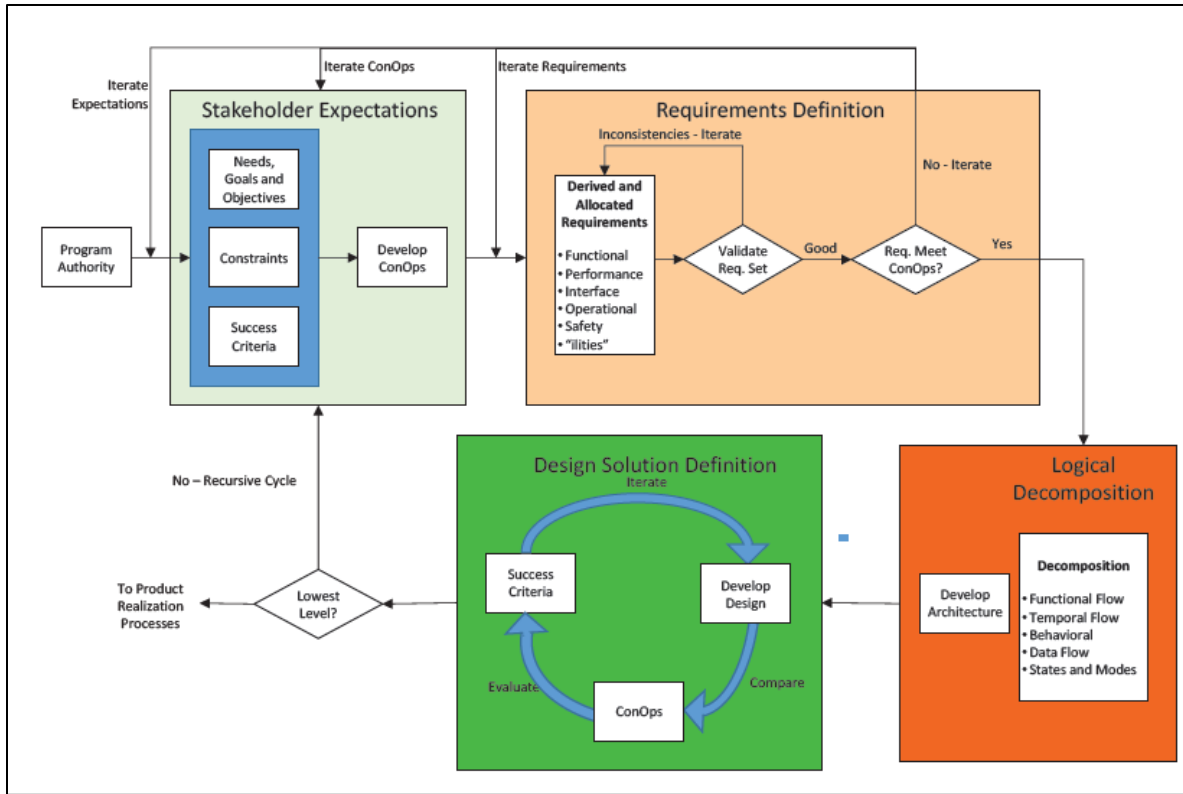

Figure 12.0: Inter-Relationships amongst System Design Processes. [1]

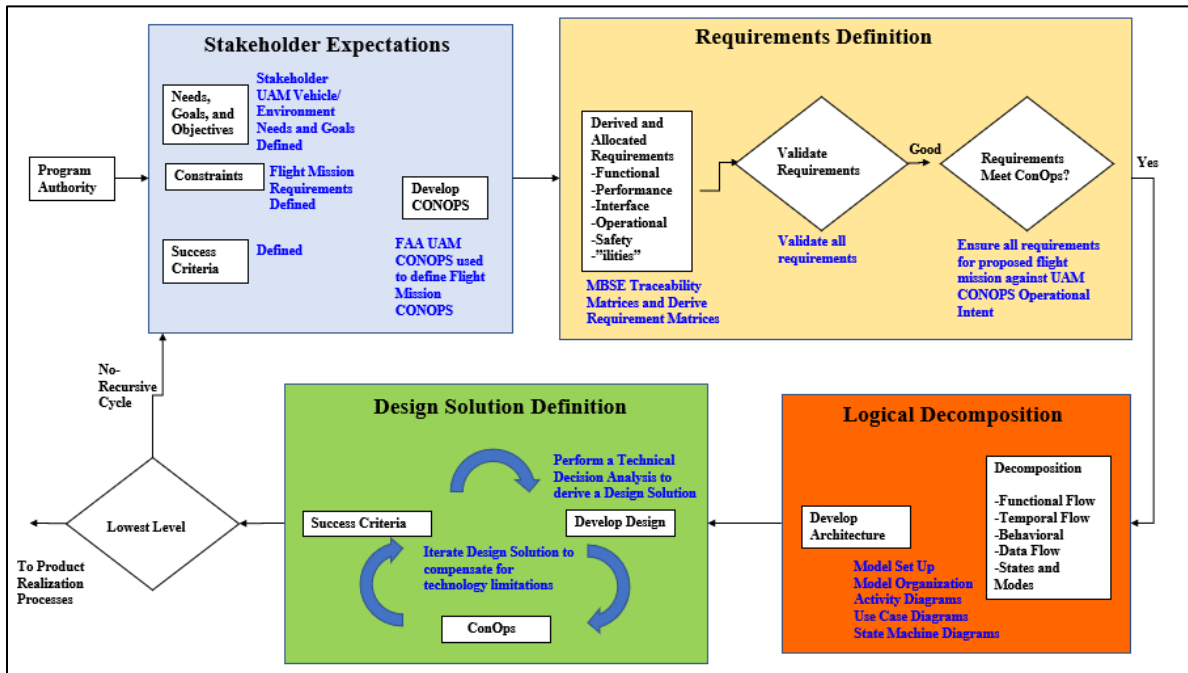

Figure 13.0: Research Methodology "Roadmap"

CHAPTER 3 – CONSTRUCTION OF THE E-VTOL MBSE MODEL

3.1 STAKEHOLDER EXPECTATIONS AND REQUIREMENTS MODELING

Capturing stakeholder needs and later mission requirements is a critical step in preparing the model. The relationship, which the top-level requirements hold with the stakeholder expectations, is fundamental in establishing the logical decomposition of the system, which then translates into the design solution/physical architecture.

Identifying the stakeholder expectations and “needs” early is beneficial in defining mission context. Likewise, the mission requirements, measures of effectiveness of the system, and the mission objectives are also derived from the stakeholder needs. Another important key element of capturing stakeholder needs is to identify stakeholder viewpoints. [28] This is traditionally modeled in diagram mode articulating what each stakeholder is primarily concerned about and how the model information addresses these concerns. Stakeholder needs can be further broken down, such as functional requirements and non-functional requirements. [28] Functional requirements can be refined by use cases diagrams whereas non-functional requirements can be demonstrated by measurements of effectiveness. Traditionally, requirements are depicted in the SysML model as requirement tables to start with before examining further with diagrams.

For the purposes of this study, requirements are broken down into three levels: Level 1, Level 2, and Level 3. Level 1 requirements are specified by the overarching authority deriving a need coming from the government or industry. Typically, the FAA, NASA, the UAM Operator, and industry would serve in providing Level 1 requirements or the stakeholder needs. Much of the guidance for the Level 1 requirements in this paper has been derived from the FAA NextGen UAM ConOps version 1.0. Level 2 requirements, or system requirements, would be derived from organizations attempting to fulfill the engineering needs classified by the Level 1 authority;

in this case, the system requirements would have to satisfy not only the Federal Aviation Regulations (FARs) but also the flight mission requirements deriving from the UAM Operator Operational Requirements. Figure 14.0 shows the relationship hierarchy for the various level requirements in a SysML requirement diagram as part of the model. Capturing the requirement relationship hierarchy early is important to build and make known the path for possible iterations, if they are needed, as lower-level design activities occur. MBSE clearly defines the requirements that bind the design engineering activities. For this effort, the flight mission requirements, the FAA NextGen ConOps, the FARs and the UAM operator operational requirements will serve as the Top Level/Level 1 requirements, but the Level 2 System Requirements only “trace” back to the flight mission requirements but still must “satisfy” the other Level 1 authorities. The flight mission requirements serve as your customer request requirements (i.e. – customer places a request to travel 50 nautical miles southwest of original takeoff vertiport site). The Level 2 requirements, the system requirements, must trace only back to the flight mission requirements (customer requirements) because regulatory authorities only define what you are allowed to do in order to meet your customer requirements. They do not define the customer requirements. As you distill the customer requirements into system requirements, the applicable regulatory requirements that must be satisfied become clear. An example of this is classification of an aircraft by weight. There is a difference in how an ultra-light aircraft versus a light aircraft must be certified. In building this MBSE e-VTOL model, the engineering model of the physical architecture would be satisfying Level 2 requirements. It should be noted here, for this research, that select Section Part 29 FARs for helicopter design were referenced as “notional” requirements for system requirements. They do not represent actual FARs that would be needed for real UAM aircraft certification/development. No actual

FARs exist yet for UAM aircraft. Level 3 requirements would be a more specialized set of requirements addressing the needs coming down from Level 2 requirements. Level 3 requirements are the subsystem requirements.

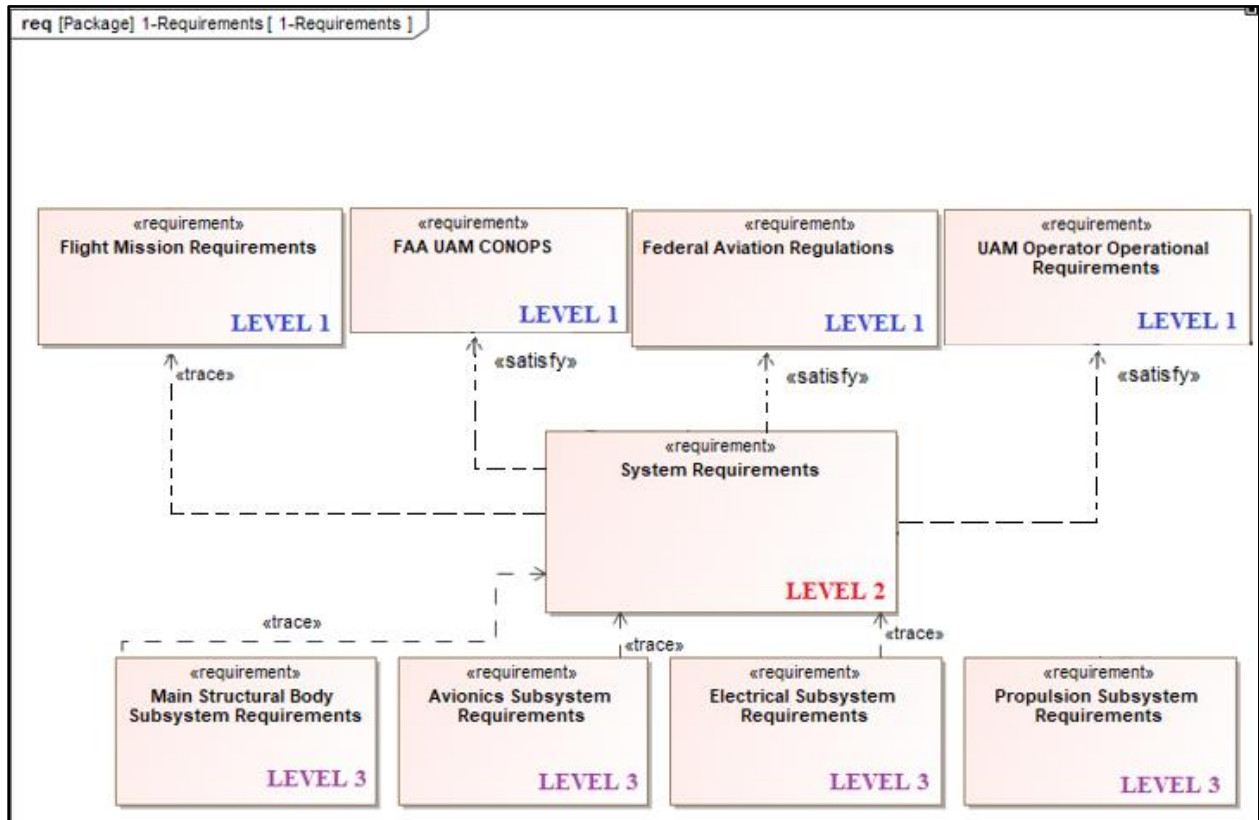

Figure 14.0: Requirement Traceability from Stakeholder Needs

As mentioned previously, the Level 1 requirements (the stakeholder needs) are derived from the FAA NextGen UAM Concept of Operations v. 1.0. Below in Figure 15.0, a SysML requirements table is displaying one set of the Level 1 requirements.

#	Name	Text
1	1-1 UAM Corridors	
2	1-1.1 Inside Corridor	
3	1-1.1.1 Aircraft Operations	All aircraft operate under UAM specific rules, procedures, and performance requirements
4	1-1.1.2 Cross Functionality	
5	1-1.1.2.1 Fixed Wing	Fixed Wing aircraft and UTM aircraft cross UAM Corridors
6	1-1.1.2.2 Helicopters	Helicopters and UAM aircraft operate within or cross UAM Corridors
7	1-1.1.2.3 Outside Corridor	Operations should adhere to relevant ATM and UTM rules based on operation type, airspace class, and altitude
8	1-2 UAM Operating Environment	
9	1-2.1 Parameter 1	UAM will operate within a regulatory, operational, and technical environment that is incorporated within the NAS
10	1-2.2 Parameter 2	Any evolution of the regulatory environment will always maintain safety of the NAS
11	1-2.3 Parameter 3	The architecture (technology) for UAM services will be flexible and scalable
12	1-2.4 Parameter 4	The FAA retains regulatory authority and is responsible for establishing operational parameters and maintain oversight
13	1-2.5 Parameter 5	Operators cannot optimize their own operations at the expense of suboptimizing the environment as a whole
14	1-2.6 Parameter 6	The FAA has on-demand access to information regarding UAM operations
15	1-2.7 Parameter 7	Airspace management will be structured where necessary and flexible when possible
16	1-2.8 Parameter 8	Cooperative traffic management is conducted in compliance with a set of community developed and FAA-approved Community Based Rules
17	1-2.8.1 CBRs	CBRs augment the UAM driver regulations and are developed by industry based on FAA guidelines and require FAA approval to address elements covered by FAA authority
18	1-2.9 Parameter 9	The FAA reserves the right to increase individual aircraft operational performance requirements in order to optimize the capacity utilization of the airspace structure
19	1-2.10 Parameter 10	Providers of Service for UAM (PSUs) will be utilized by operators to receive/exchange information during UAM operations
20	1-2.11 Parameter 11	PSUs will be able to UTM flight information via the UAS Service Supplier (USS) network, and the USS network will be able to obtain UAM flight information via the PSU network

Figure 15.0: Stakeholder Needs for the UAM SysML model

For the Level 1 stakeholder needs, the operational requirements must satisfy any top-level needs. Figure 16.0 shows a requirement table of the UAM Operator Operational Requirements. This is further broken down in Figure 17.0, which shows how the flight mission requirements must satisfy not only the operational requirements of the operator, but also the FAA UAM NextGen ConOps and the FARs. The operational requirements were researched from publicly available data from generic UAM flight mission profiles, inclusive of a needed information concerning flight range, payload specification, vehicle movement, energy quantification, and reserve capacity. Level 2 requirements are concentrated on aircraft system detail design and development, which are derived from the UAM operator “operational” requirements and the FARs. At Level 3, the requirements are focused on the subsystem requirements which trace back to the system requirements. Below, in Figure 16.0, is a SysML requirements table for the UAM Operator Operational Requirements.

1	R 27 Vehicle Movement	Must be able to hover and takeoff and land vertically
2	R 28 Noise Reduction	Noise signature should be on the order of 15dB quieter than existing helicopter designs; about 70 dB SEL at 500 ft versus 85 dB for a helicopter of similar weight
3	R 29 Energy Storage	Should operate entirely on battery-electric energy storage or a hybrid design utilizing liquid hydrocarbon designs
4	R 30 Vertiport Infrastructure	Must be able to perform operations within an infrastructure of vertiports / terminal landing and takeoff areas
5	R 31 Mission Payload	Must be able to transport pilot and 4 passengers including luggage weight; maximum payload weight of 1200 lbs including luggage
6	R 32 Network Communications	Must have a secure bi-directional API (application programming interface) for network communications for UAM airspace infrastructure. Must be able to transmit/receive flight plans and relay location and battery capacity.
7	R 33 Mission Range	Must be able to travel up to 50 miles
8	R 34 Reserves	Must have enough energy capacity to perform a balked landing at original vertiport site and perform a diversion to an alternate landing site 5 miles away

Figure 16.0: UAM Operator Operational Requirements

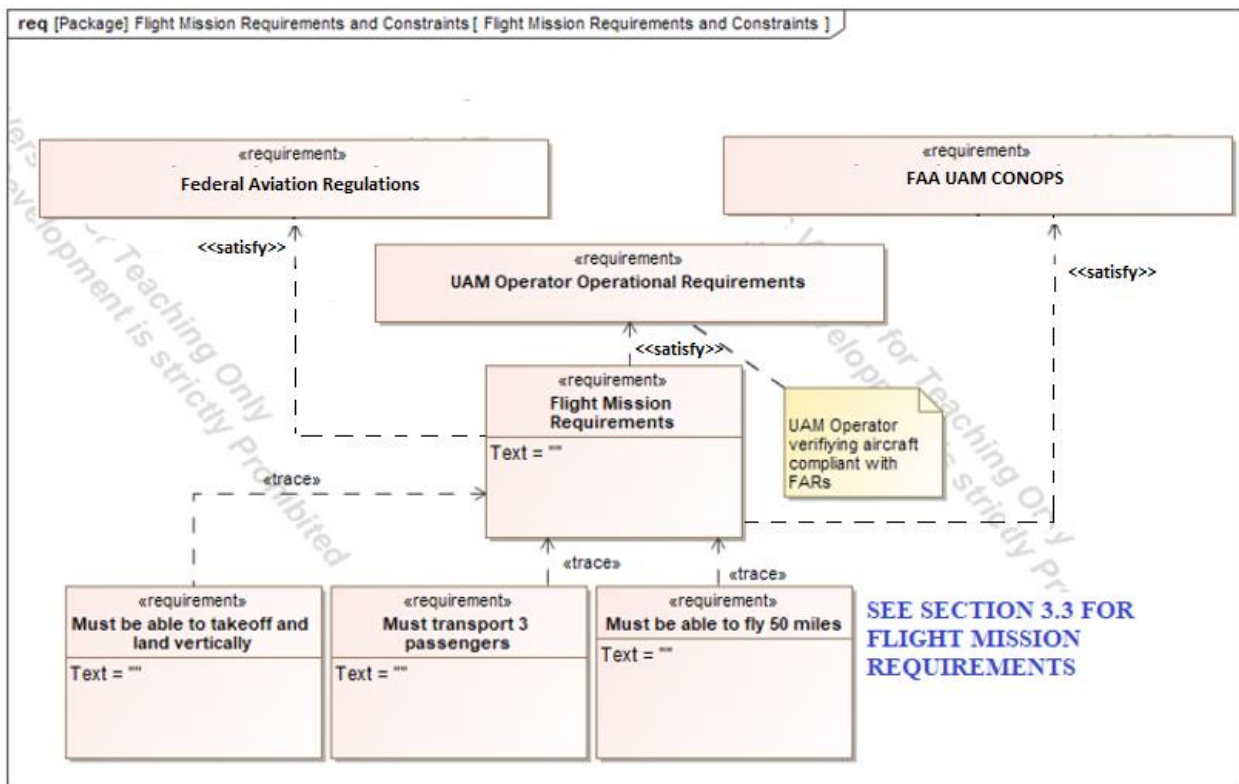

Figure 17.0: Traceability of Flight Mission Requirements

For future MBSE model updates, the model could adapt to a real-world hierarchy by separating aircraft requirements into categories such as economic requirements, regulatory requirements, system constraints, and specialty requirements. Economic requirements are derived from market analysis and trends. Regulatory requirements trace to the FARs and Joint Aviation Agencies (JAAs) which set the cadence for aircraft certification. A system constraint would be weight requirements, of which Manufacturer Empty Weight (MEW) and Maximum

Takeoff Weight (MTOW) are the most important. Any specialty requirements would be in aircraft reliability and human factors. [39]

3.2 PROPOSED LEVEL 1 FLIGHT MISSION REQUIREMENTS FOR ANALYSIS

For the study proposed in this thesis, the following is the mission profile that will be used as the flight mission parameters from which a design solution is modeled in a model-based systems engineering platform. This set of requirement parameters is based on current industry and academic research models. It is also roughly based on the mission requirements of Uber Elevate's program [40], the scenario requirements from NASA's National Campaign [5], and other scholarly publications [29][30][43] involving research in e-VTOL aircraft/flight mission development. To establish a frame of reference, the location of the e-VTOL mission is set in the Atlantic City regional area originating from a vertiport located near Atlantic City International Airport and flying to a vertiport near Cape May Airport. The flight path for this prescribed mission is depicted in Figure 18.0. This location is an ideal selection as the FAA, NASA, and local community have expressed interest in adopting this area along the Jitney Route in Atlantic City as an early adopter location for UAM operations. The general Level 1 flight mission requirements are set forth as such [5] [29] [30] [40] [43]:

1. Must be able to transport 3 passengers + 1 Pilot in Command (PIC)
2. Be able to support a payload weight of 1200 lbs.
3. Must be able to transport three passengers to a vertiport terminal landing area in Cape May, which is ~ 44.6 miles southwest of Atlantic City International Airport (vertiport).
4. Must have a minimum travel range of 50 miles => 44.6 (miles)/38.75 (nmi) + additional takeoff and landing travel distances

5. Must be able to take off and land vertically
6. Must be able to hover
7. Maximum climb speed at 150 mph
8. Onboard weather monitoring system
9. Must have a maximum cruise speed of 150 mph at 2500 feet AGL
10. Minimum cruising altitude set at 2500 feet AGL
11. Maximum cruising altitude set at 3000 feet AGL
12. Average climb rate not to exceed 500 feet/min
13. Descent rate not to exceed 1,000 feet/min
14. Must have onboard communication equipment to communicate with ATC/PSU
15. Must be able to divert to an alternate landing spot located at a distance of 5 statute miles from the original location
16. Must be capable of VFR and IFR flight
17. Must have an autopilot feature
18. Must have contingencies in case of a water landing
19. Acceptable structural weight of a UAM vehicle needs to account for not only flight loads but also crash events.
20. Must have in-built contingencies for a balked landing/go-around.
21. Aircraft must have operational contingencies for complex and dense airspace. For this flight mission, there are 20 other aircraft flying in this airspace.

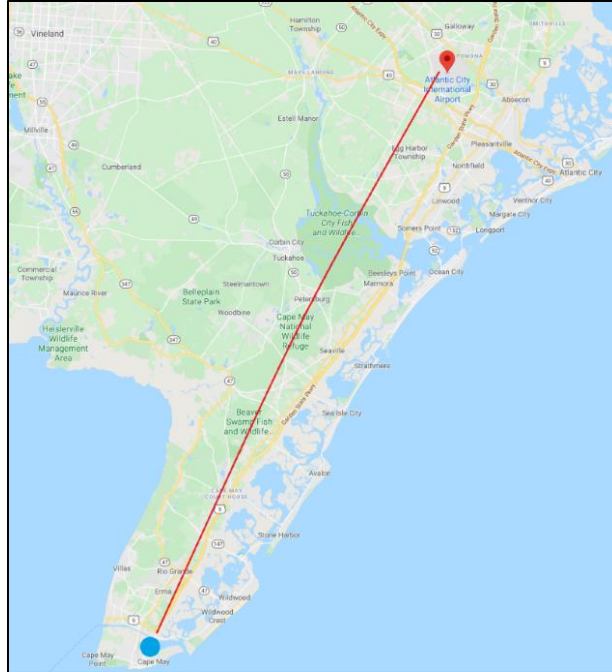

Figure 18.0: Flight Path for e-VTOL Aircraft

3.3 FLIGHT MISSION ENVIRONMENT AND CONCEPT OF OPERATIONS

As mentioned previously, the Concept of Operations framework laid out in the FAA NextGen UAM ConOps version 1.0 is adapted for this study. The UAM Operations Environment (UOE) consists of several different actors who operate in this environment to successfully execute flight missions in specific volumes of airspace called “UAM Corridors”. Figure 19.0 depicts an illustration of a UAM Corridor as defined in the FAA UAM ConOps.

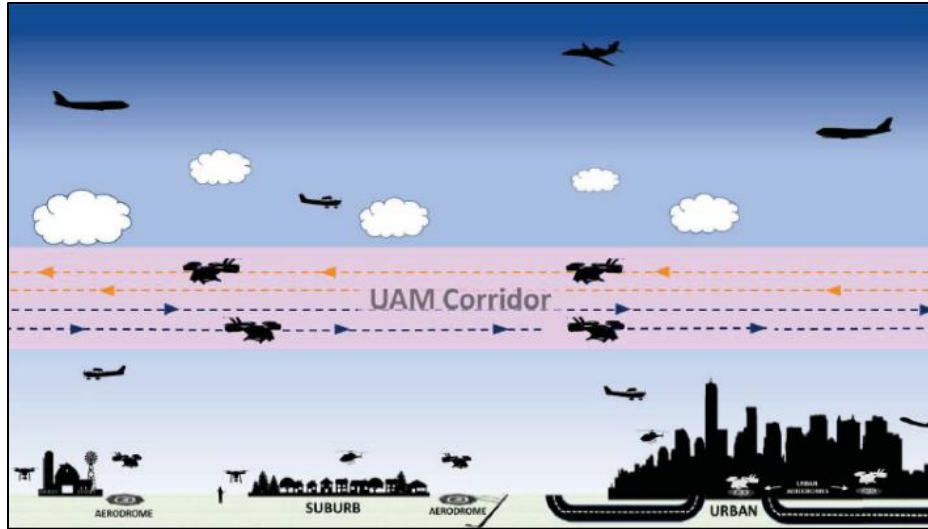

Figure 19.0: Urban Air Mobility Corridor [2]

The location from where the flight operation departs or arrives is called the UAM “aerodrome”. Inside the aerodrome is the vertiport, where the actual takeoff and landings occur. The actor conducting operations in these 3-dimensional airspace volumes is the UAM Operator. The UAM Operator is responsible for addressing service requests from customers, executing this on-demand service using UAM aircraft. To derive “Operational Intent” for the flight (such as location of flight, route, desired flight time), the UAM operator must go through a series of data exchanges with the Provider of Services (PSU) and the Supplemental Data Service Provider (SDSP) to obtain current state conditions (vertiport availability, strategic operational demand, environmental data, and situational awareness). Once the operational intent has been established, the UAM Operator must submit operational data to the PSU Network to then conduct a UAM mission within a UAM corridor. From here, operations are intended to be managed by vertiport operators, several PSUs, and aircraft/fleet operators aided by automation. [2] Figure 20.0 illustrates the proposed flight mission ConOps adopted to for this study. Aircraft depictions from [25].

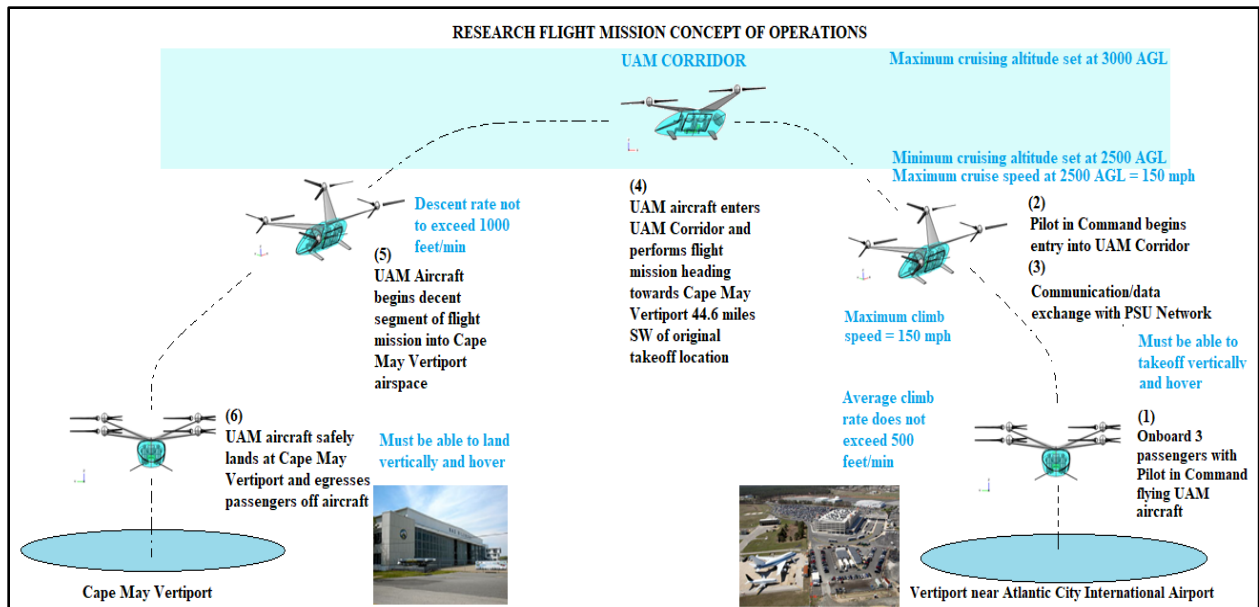

Figure 20.0: Flight Mission ConOps

3.4 DEFINING LOGICAL ARCHITECTURE

In following the research methodology roadmap from Figure 13.0, defining logical architecture is the next stage. At this point, it is imperative to provide some additional detail on planning the model activity to serve in providing that definition to logical architecture. It is an action taken with a fresh perspective to define the mission objectives and scope as well. In this virtual environment, the mission objectives must support the mission context. The objectives should concisely ensure the aircraft architecture fulfills that requirements needed by the stakeholders involved. As such, the objectives are needed to update any model artifacts and address any information needs. [18] Additionally, at this stage a schedule for the resultant model artifacts should be established to ensure deliverable schedule is retained. From the objectives, the logical architecture must be derived. From the logical architecture, the physical architecture can then be defined. The “Planning the Model Effort” can be characterized in Figure 21.0. The

definition of logical architecture would occur between “Analyze Mission and Stakeholder Needs” and “Specify System Requirements” in Figure 21.0.

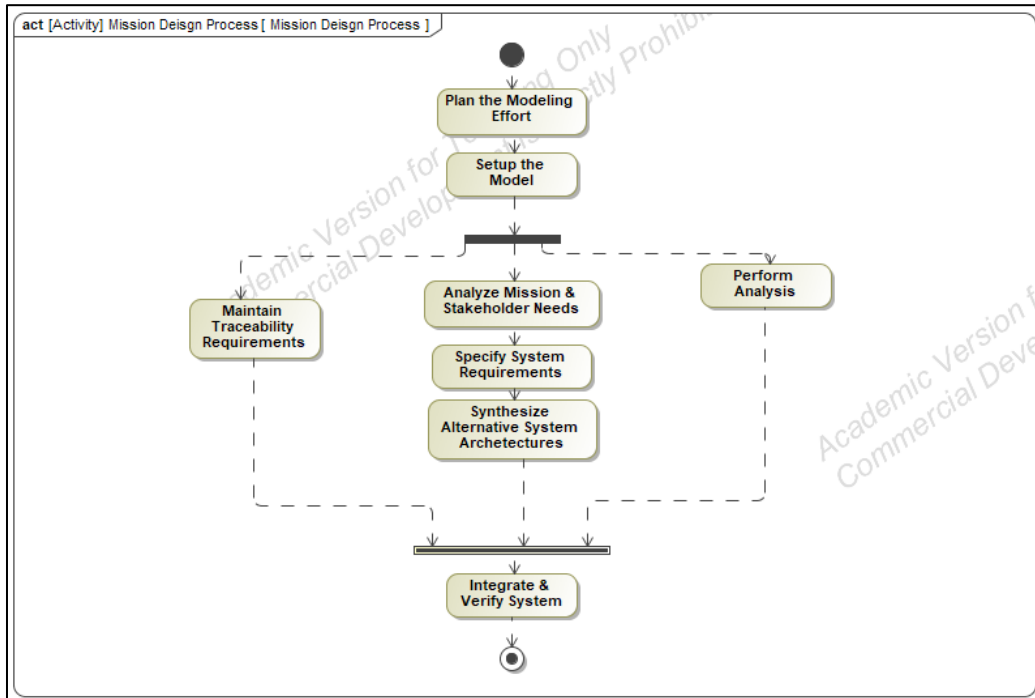

Figure 21.0: Plan the Modeling Effort Activity Diagram [18]

3.5 MODEL ORGANIZATION AND CONTAINMENT TREE

The next step in the process is establishing model organization. In SysML, this can be aptly shown by use of packages. A SysML model structure is organized in its “containment tree” by a series of packages (depicted in Figure 22.0); some packages having nested packages inherent inside those packages. In referencing the four pillars of SysML, one can establish the framework for the model organizational containment tree and build the structure from those four pillars. [28]

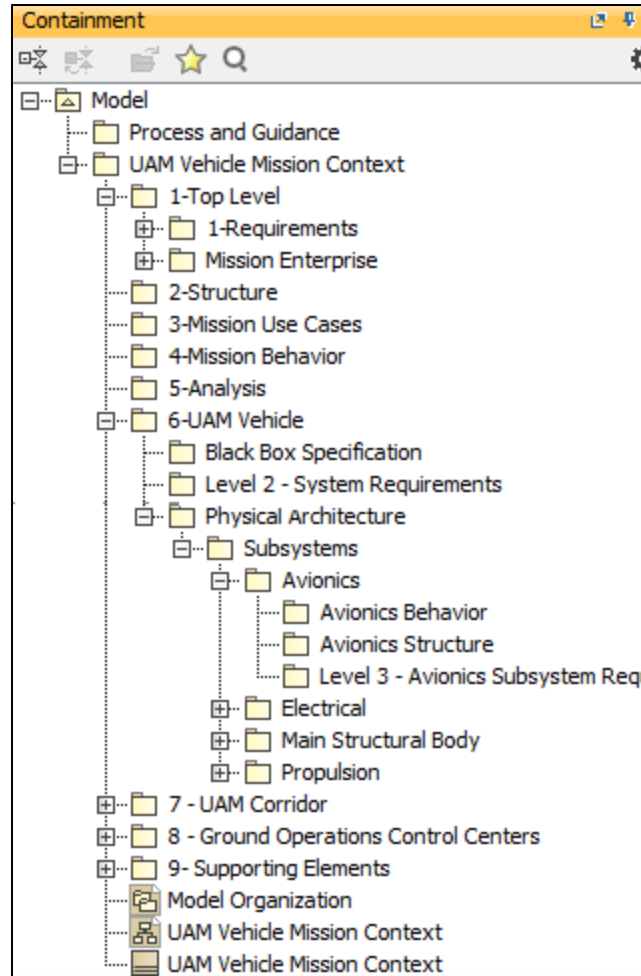

Figure 22.0: Model Organization in the Containment Tree

It is important to note that in establishing model organization, there is no one distinct standard. There are several different ways to organize a model in Cameo Systems Modeler or other platforms. This paper referenced “Architecting Spacecraft with SysML” alongside NoMagic online documentation to provide guidance. Additional guidance on model construction and fundamentals was derived from “Developing a CubeSat Model-Based Systems Engineering (MBSE) Reference Model – Interim Status” [41]. In ref [41], it is also emphasized how important it is to capture the operational domain of the system and show the flow down of the requirements from the mission objectives.

The mission context displays all the elements with which the aircraft interacts and the environment in which it operates. [28] These elements can either be direct or indirect interaction with the aircraft but can include external actors to the system and subsystems. In Figure 23.0, the mission enterprise is specified as a BDD block connecting to the mission context. The measurements of effectiveness (MoEs) are typically captured under mission enterprise. The MoEs capture how well a system carries out a task within a specific context; however, they do not gauge the task performance. [28] The MoEs can be also used to quantify the stakeholder value of an intended solution.

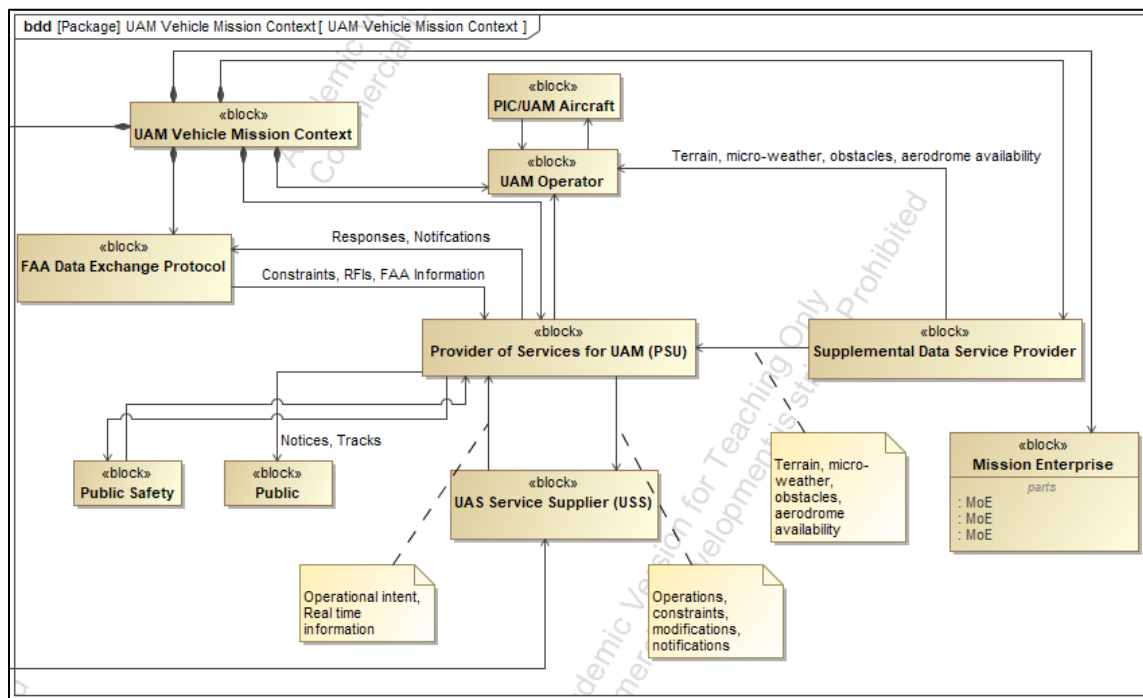

Figure 23.0: Block Definition Diagram of the Mission Context [2]

In this study, a mission context package diagram called “UAM Vehicle Mission Context” is created as depicted in Figure 24.0. This package diagram organizes the model hierarchy into packages. This could be considered an early step in model creation by establishing the model organization package diagram. The containment tree will further populate as the model

organization package diagram is populated. The actual UAM/E-VTOL physical architecture is further broken down in part “6 – UAM Vehicle” in the package diagram as seen in Figure 24.0. The black box specifications are mentioned here. To understand the “black box” system concept, it is important to understand that this is a display of the system components that do not actually belong to the system itself, but more so interact with the system. This also includes human actors, which interact with the system as seen from the outside. External performance requirements are also part of the black box specification, for example, “provide power to the system”. Black box specification differs from white box specification in that white box specification examines the system from an internal perspective. [28]

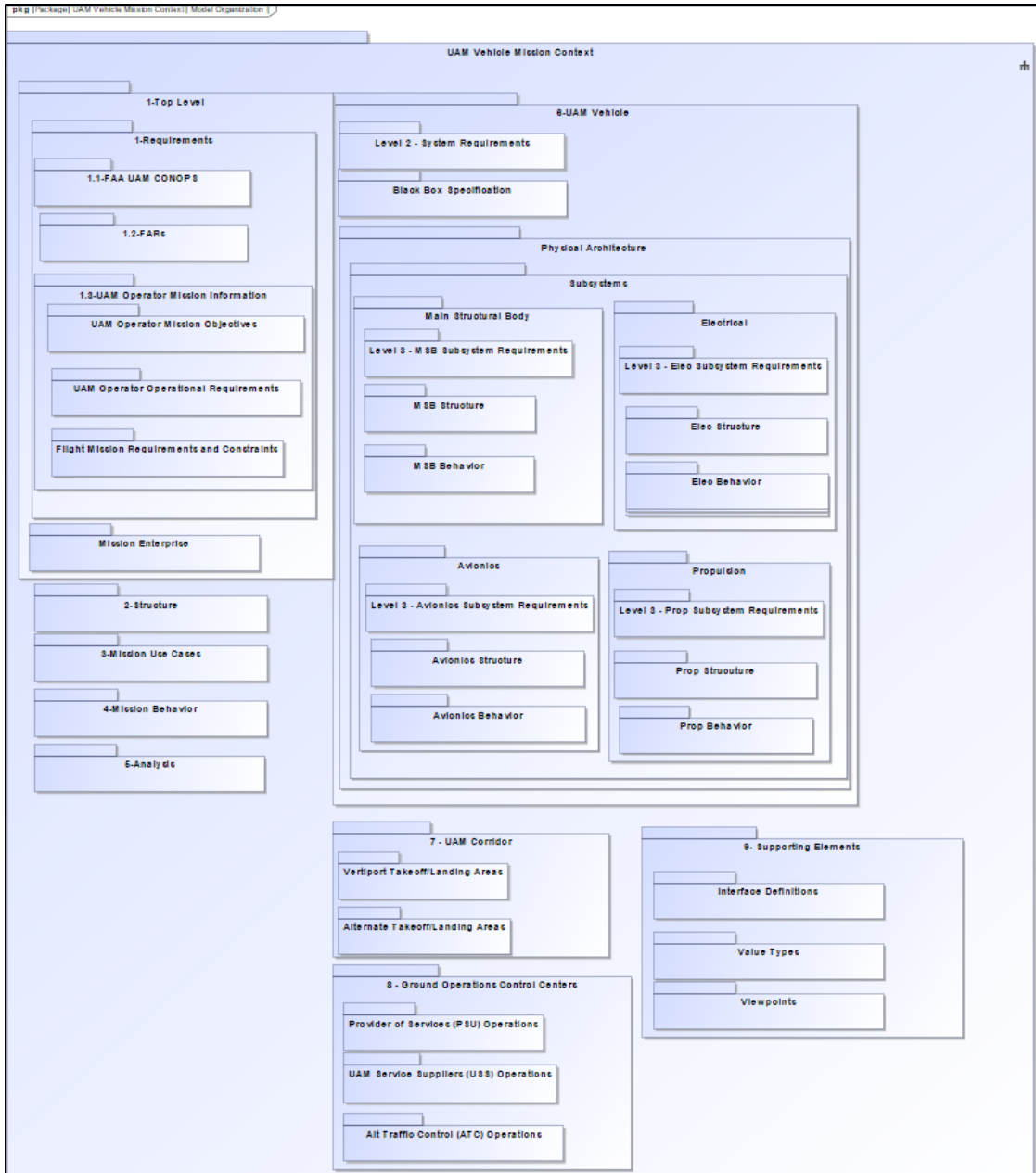

Figure 24.0: Package Diagram of the Model Organization

3.6 USE CASE MODELING

Encased in the original package diagram for the mission context is a package containing “Use Cases”. As stated earlier, the mission objectives are derived from the stakeholder needs. These objectives are often signified as use case diagrams emphasizing how these objectives are met within the scope of the mission context and invoking the roles of the actors involved. The actors are shown in the use case diagram interfacing with the system externally to complete the pre-defined mission objectives. A **Use Case Diagram** (UC) that can also be used to define a set of use cases performed within a particular system context, representing a black box view of the system of interest. It also can create associations between different use cases and the actors of the system context, to specify who/what is responsible for invoking or participating in what use case. Once use cases are defined, state machine diagrams, sequence diagrams, and activity diagrams are constructed to show stakeholders how the mission objectives can be achieved at the subcomponent level. Typically use case diagrams fall under Behavior modeling, but a separated in the model organization in this study in their own package. Below in Figure 25.0, is a use case diagram addressing a basic flight mission use case and the actors involved. [28] As illustrated in this figure, the major stakeholders are addressing a market /demand need to have the objective of conducting UAM flight missions met. The UAM Operator objective is to maintain and physically conduct flight missions, as it is the entity responsible for this operational velocity. Although the Provider of Services (PSU) acts to support the original stakeholder need to conduct these operations, their objective differs in that this service supports the UAM Operator through a series of data exchanges to provide operational information. The Supplemental Data Service Provider (SDSPs) and the UAS Service Suppliers (USSs) receive supplemental information to provide to the PSU, who then can inform the UAM Operator concerning UAM corridor

environment information. In the FAA NextGen ConOps, the UAM Operator can interact with the SDSPs independently as well outside the PSUs. All information provided helps the UAM Operator meet operational and regulatory requirements within the UOE.

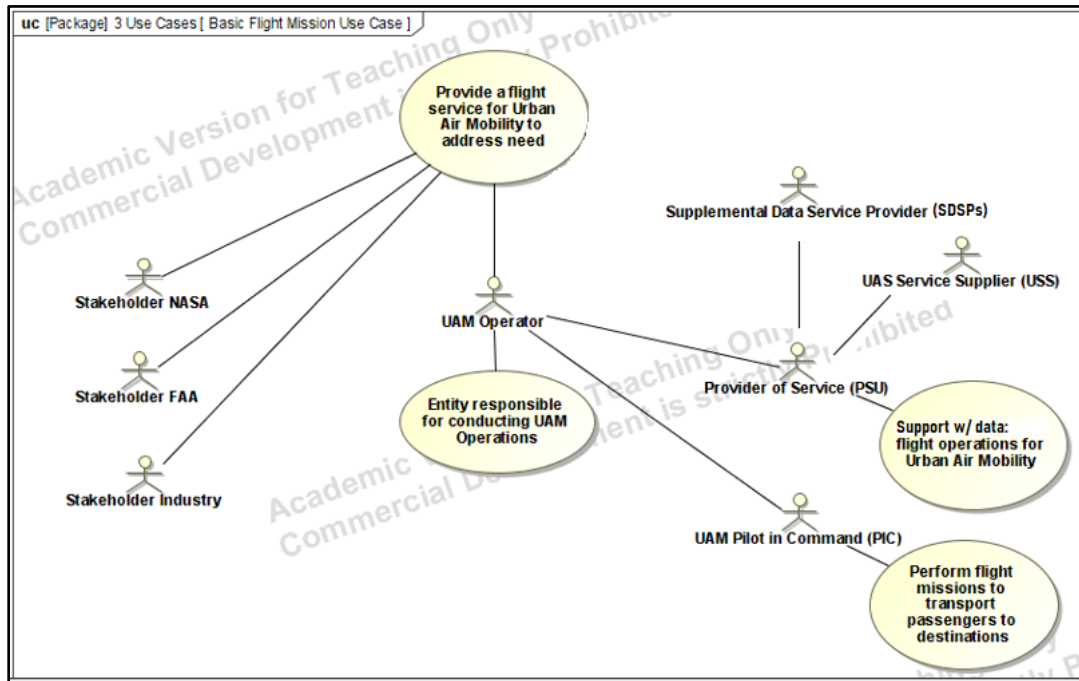

Figure 25.0: Basic Flight Mission Use Case Diagram

3.7 BEHAVIOR MODELING

The primary diagrams associated with modeling behavior are Activity Diagrams (ACT), Sequence Diagram (SD), State Diagrams (STM), and Use Cases Diagrams (UC). [28] A SysML **Activity Diagram** is composed of a series internal blocks and symbolic representations of inputs and outputs displaying logic control flow in the activity being performed. [28] The activity in question represents a flow of operational behaviors. Activities and action can be represented by control blocks, often depicting a series of system actions or those inherent of a subsystem. In the SysML environment, an activity diagram can be nested inside another activity, such as in Figure 26.0. In this activity depiction, a basic flight mission profile is drawn out as logical sequential

activity connecting each internal action. Much of the logic flow in this diagram is dependent on “clearance” actions being provided so the activity can move onto the next action, such as the whole activity awaiting clearance for takeoff to begin the mission. If this clearance is not given, the flow is routed to wait for this action to occur. If this activity is still not satisfied, the activity terminates with ending the flight mission. In the same sense, if clearance to land is not provided, the operator must wait for further instruction to either perform a go-around/reroute. This is typically referred to as a bailed landing and can occur for several reasons. A common reason is vertiport availability. In the “Perform Vertical Takeoff” Action, later depicted in Figure 27.0, a rake (↗) icon is present in Figure 26.0 for this activity. This indicates there is an internal activity diagram associated with “Perform Vertical Takeoff”. This demonstrates the SysML model’s capability of system decomposition. Figure 27.0 provides additional detail as to possible steps that could occur during a takeoff procedure, such as pre-flight and equipment checks performed prior to departure.

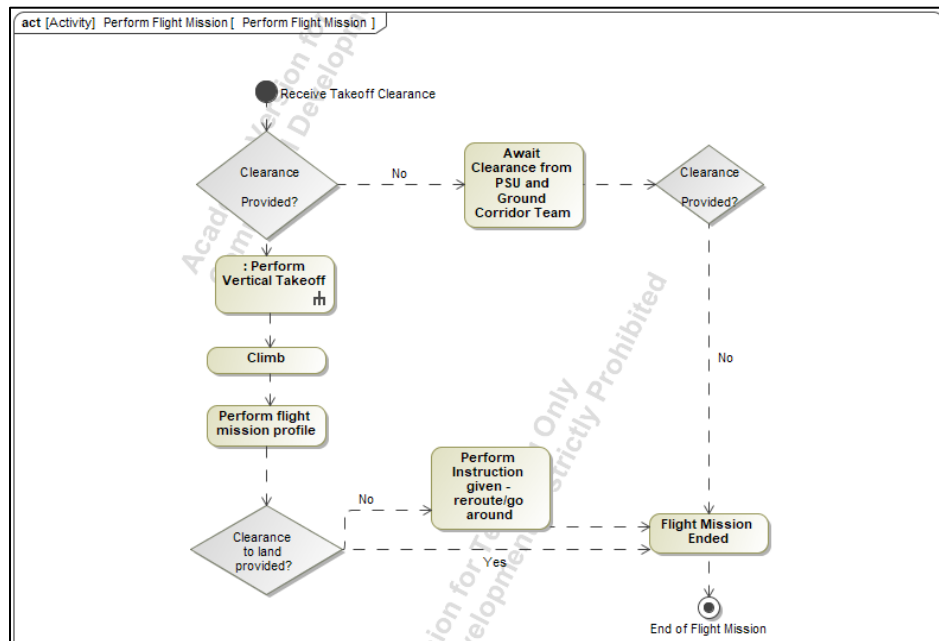

Figure 26.0: Activity Diagram of “Performing Flight Mission”

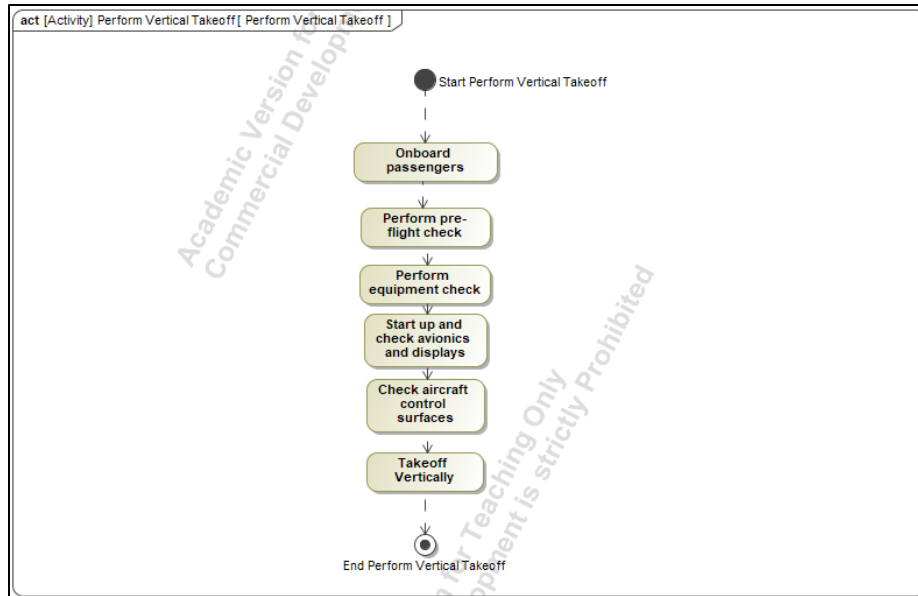

Figure 27.0: Activity Diagram of “Perform Vertical Takeoff”

An activity diagram is an extension of the UML Activity Diagram, for which the purpose is to specify dynamic system behaviors that satisfy system Functional Requirements using both Control and Object (data) flows. Control flow represents the flow of functional behaviors whereas the object flow is a phrase used to depict how the output of one action interconnects to the input of a second action. Control and Object Flows can be sequential (default) or working in parallel. This flow construction includes fork and join nodes depending upon conditions. The behavior of the system or subsystem also shows the sequential logic flow. Activity information can also be represented into logical “swim lanes” to build a logical architecture of the activity in question in terms of the system control flow functioning in parallel or in series, as depicted in Figure 28.0. [28] Swim lanes provide visual assistance in viewing from the swim lane owner’s perspective and what actions are in their own queue. In Figure 28.0, the swim lane for the Provider of Services shows that it is interacting with the e-VTOL aircraft by use of a 2-way network communication application program interface (API) for all actions listed under this swim lane. The e-VTOL aircraft in turn takes this data exchange to support its own actions in its own swim

lane, such as receiving mission instructions from the PSU. The e-VTOL can then receive these instructions, which support maneuvering activities within its flight corridor.

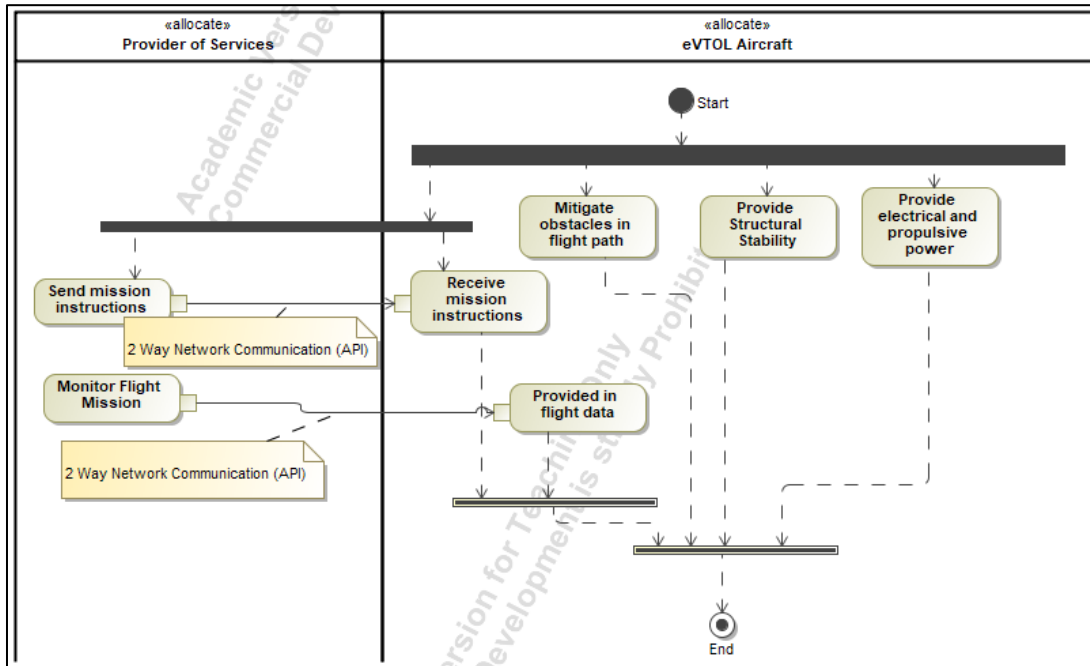

Figure 28.0: UAM Activity Diagram with Component Swim Lanes

SysML control block modeling is especially useful when modeling specific flight mission models. It not only captures the activities involved in the operation performed but also reveals needed requirements to perform the mission. This is best illustrated in Figure 29.0. The activity diagram detailed in Figure 29.0 is the MBSE version of the Flight Mission ConOps diagram (Figure 20.0) outlined in Section 3.3 of this paper. In Figure 29.0, the activity flow showcases the same information with the diagram in Figure 20.0, by starting with the onboarding of the 3 passengers at the takeoff vertiport site all the way through landing at the vertiport site in Cape May. Activity diagrams can also play a key role when addressing non-routine (off-nominal) events that occur in flight operation stages to show what the course of action logic flow would potentially be based on current state airspace operational knowledge; this will be discussed later in the paper.

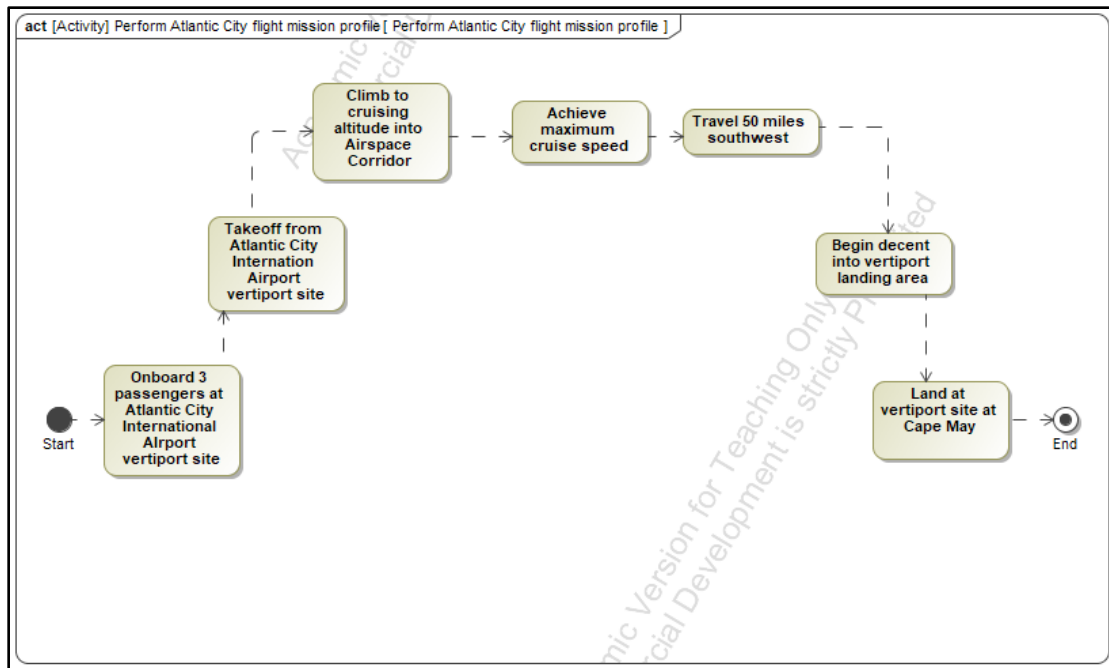

Figure 29.0: Activity Diagram for Atlantic City Flight Mission

An activity diagram of the various “swim lanes” in the operational environment in depicted in Figure 30.0. For this diagram, the acronym “PAX” means to passengers. In this activity diagram though, there is a distinct order of operations when swim lane owner actions appear in relation to the process of conducting a simple UAM operation. There is also an indication of responsibility for certain actions along this process, such as the UAM vertiport taking the responsibility of screening the passengers before takeoff during the onboarding stage. Of note in this diagram, is that from the perspective of the UAM Aircraft swim lane, there is a nested activity in performing the actual flight mission, which has a series of actions embedded in this activity to taxi, takeoff, perform the flight, and terminate this activity by landing if the flight status is a routine event. This diagram is a coherent example of how activity diagrams can capture multiple pieces of information about an activity simultaneously.

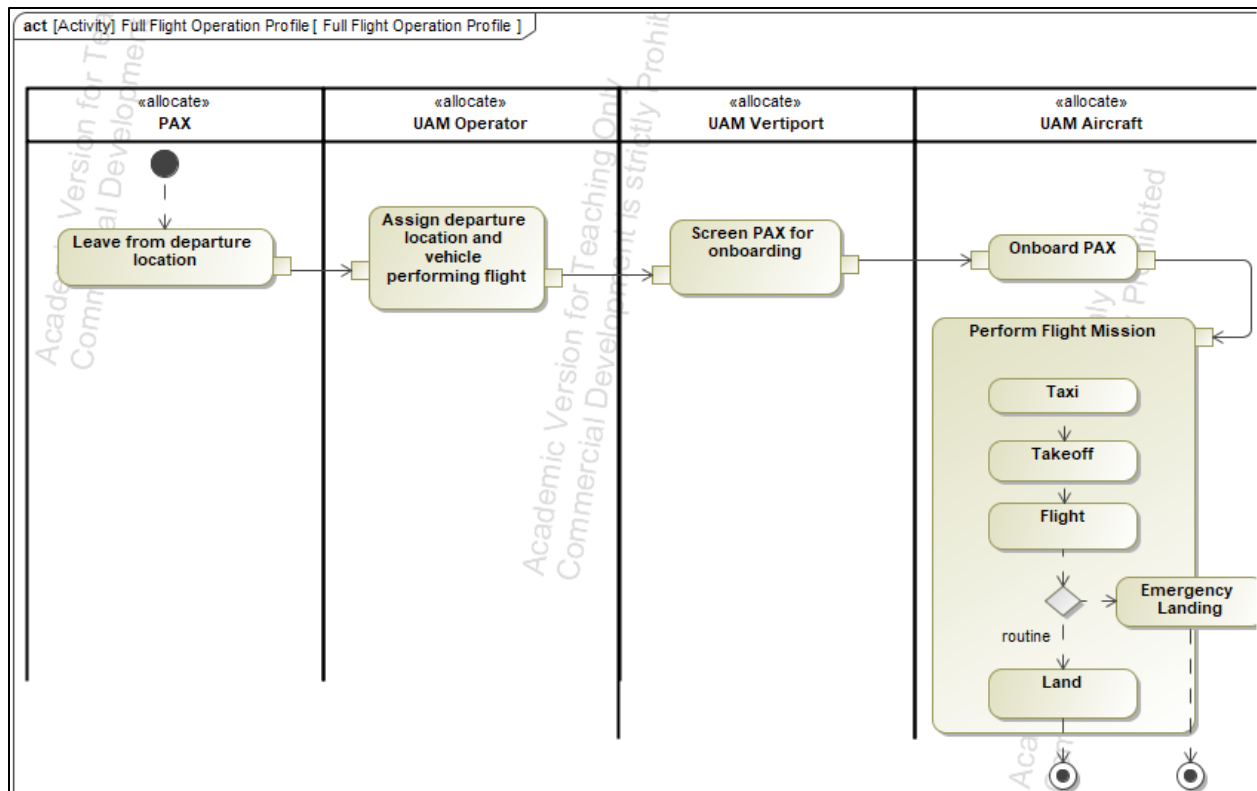

Figure 30.0: Activity Diagram for a UAM Flight Operation

It is important that the granularity of system structure and behavior be consistent in each level of detail in the model’s behavioral description. Supporting this concept is the creation of **Sequence Diagrams (SD)** in the SysML model. A sequence diagram provides a sequential map of certain elements in a system inclusive of the interactions between actors and operational actions contained within. This diagram variety illustrates the “timeline” of these interactions. In Figure 31.0, a sequential timeline is established for placing a flight mission request from the beginning of the sequence starting from when the customer orders a flight from the UAM Operator. As you can see in Figure 31.0, instances are created in this type of diagram, as the creation of the Service Appointment did not exist prior to the instantiation of the PSU collecting data pertaining to the aerodrome operational conditions. The PSU does not begin the operational environment query (such queries include operational intent ensuring strategic deconfliction,

UAM corridor capacity, airspace restrictions, aerodrome resource availability and inclement weather conditions) [2] until the UAM Operator provides operational intent to the PSU. A sequence diagram is an excellent way to demonstrate causal relationships between operators within the system environment. [28]

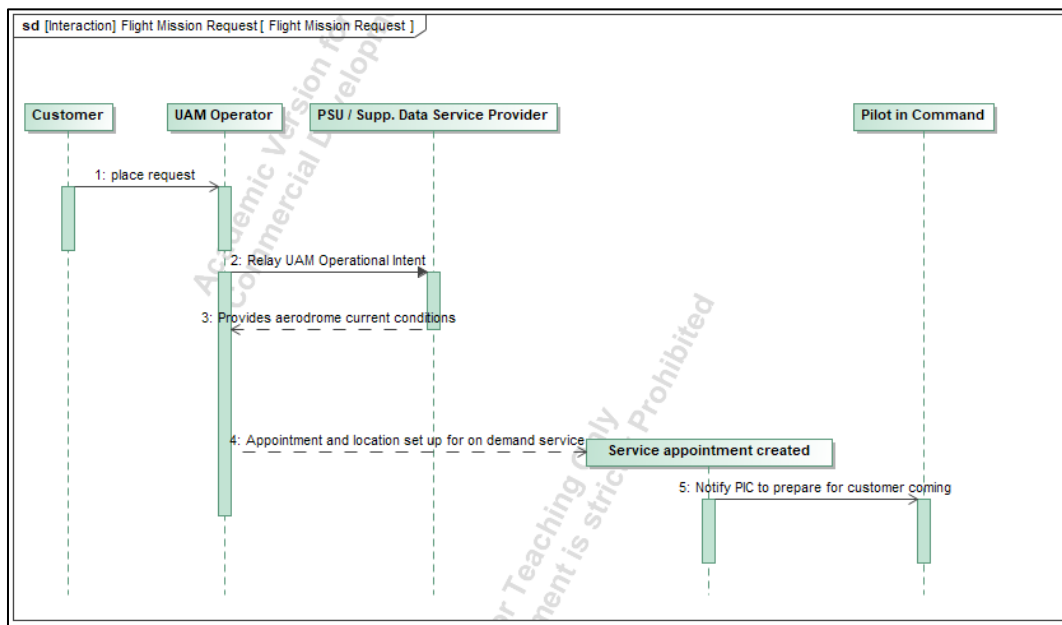

Figure 31.0: Sequence Diagram for a Flight Mission Request

The next type of diagram, which is conducive at highlighting a system’s behavior, analyzes the states at which a system undergoes. This is referred to as a **State Machine Diagram (STM)**. This type of diagram depicts the transitions from different operative states, for example, turning an autopilot feature onboard an aircraft from a state of “on” to “off”. States can have several internal behaviors that are specified in the form of SysML activity diagrams created somewhere in the model. Hence, state machine diagrams can be constructed with activity diagrams nested internally to capture a specific model behavior. This is especially helpful when it comes to flight operation modeling where each “state” the aircraft is transitioning from is a complex activity in itself, such as a layered operational segment when the aircraft is flying. Another aspect of a state

machine diagram is the exhibition of exit, entry, and do type behaviors becoming defined by the “use” to help quantify the purpose of a block while in a specified state. Figure 32.0 depicts a generic state machine diagram for different aircraft operational “states”. During the state of “Flying”, there are four embedded states exclusive to “Flying”; they are “Autopilot”, “Descent”, “Cruise”, “Straight and Level Flight”, and “Climb”. Of added note in this figure, is the use of composite states. An eyeglass figure is located next to each composite state. As the state of “Turns” is not specific to just the “Cruise” state in this figure but also is applicable to “Climb”, this can be depicted as a composite state. Composite states are states which have substates (nested states) Substates can be nested to any level as shown in this figure. To add further detail to a state, notes can be added to describe what is occurring at that state, such as in the “Approach” state notes which indicates to decrease airspeed, elevation and altitude. [18] [42]

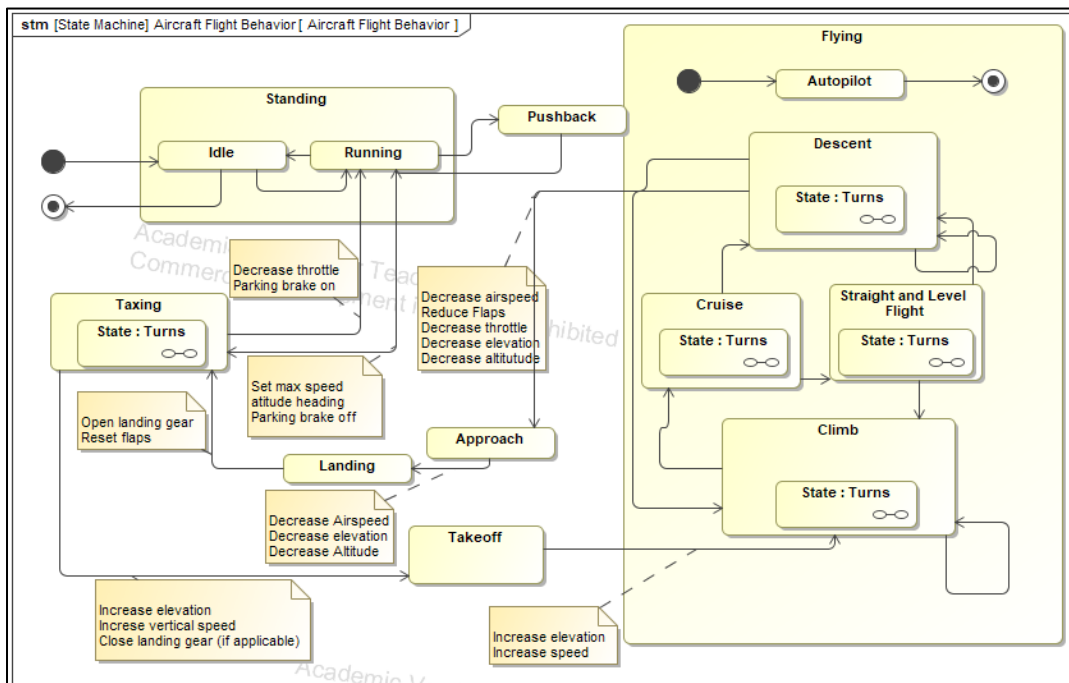

Figure 32.0: State Machine Diagram of Aircraft Flight Behavior [42]

As it is imperative to identify key activities that demonstrate system behavior, so is it equally important to identify top-level failure modes that would produce mission failure. The

level of failure modes is a functionality of how complex the system activity is. A failure mode can be quantified as abstract constraint violation. An activity violation could occur at a failure point for a nested activity. For example, “Perform Flight Mission” would fall into a failure mode constraint if the activity “Perform Vertical Takeoff” prompted a failure constraint violation in Figure 33.0. Likewise, if there were an interruption in traveling inside the UAM corridor, this would fall under an off-nominal constraint violation. An example of an off-nominal violation would be an in-flight mechanical total failure. Similarly, if the e-VTOL aircraft were unable to provide flight data to the PSU, this would have serious consequences in flight domain situational awareness within the corridor. The top failure modes that have the highest probability of causing a mission failure are essential to measure initially to reduce their probability of occurrence. This type of systems analysis could be beneficial in later research involving a detailed Failure Mode and Effects Analysis (FMEA). [28]

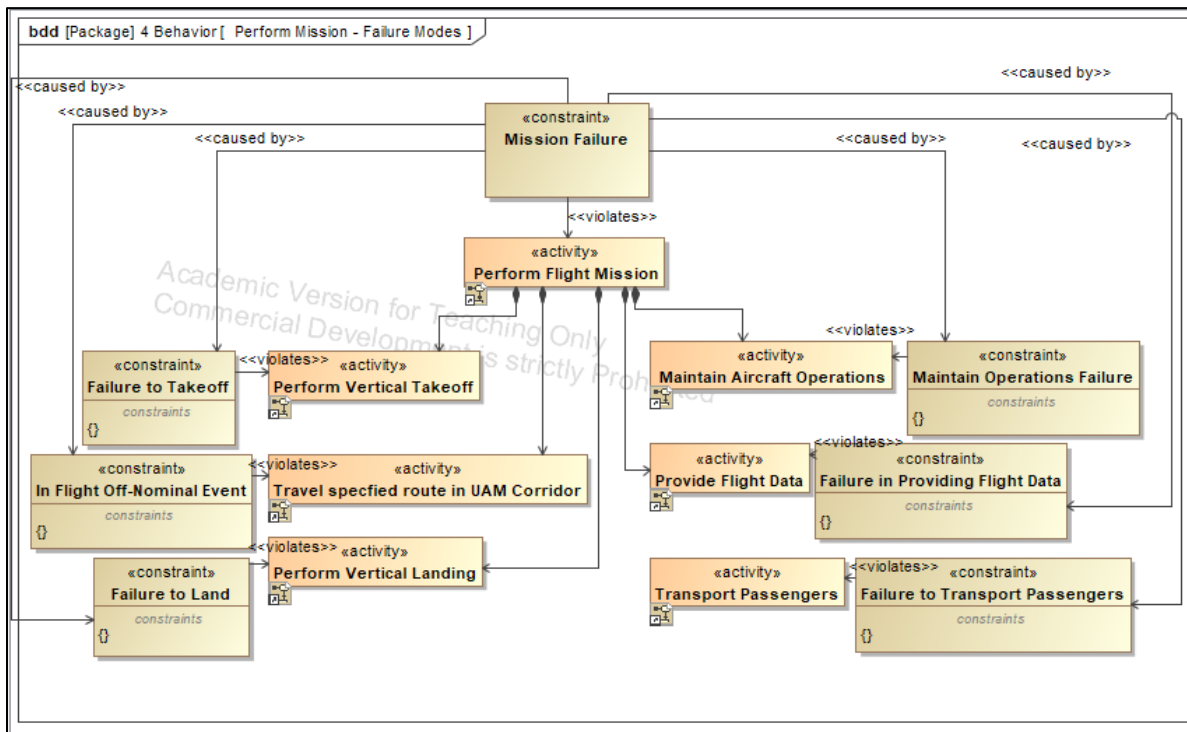

Figure 33.0: Block Definition Diagram for Perform Mission Failure Modes

3.8 STRUCTURE MODELING

The proposed design solution was highly inspired by the Mistral Air Taxi conceptual design in ref [43] and the Lilium Jet design in ref [13]. These concept vehicles illustrated the level of variety in design choices relevant to a study focused on building a functioning aircraft that met certain mission use cases. As the performance metrics of the Mistral Air Taxi were similar to the Lilium Jet design, this helped in verification of needed subcomponents to support this type of design. Both aircraft are depicted in Figure 34.0 and 35.0.



Figure 34.0: Concept Vehicle Graphic of the Mistral Air Taxi [43]



Figure 35.0: Lilium Jet 5-Seater Aircraft [13]

The designed vehicle includes a distributed electric propulsion (DEP) system, a wing (2 partitions) and canard configuration, a vectored thrust propulsion system where the engines are directly affixed to the fuselage via the canard roots, and a differential thrust system for yaw

movement. The DEP system leads into increased range, while boundary layer ingestion also helps to a decrease in total pressure losses in the system and improve overall efficiency. [43] The wing section includes 16 electric motors, each motor powering a ducted fan each, with 8 motors per each partition of wing. The canard section has a total of 8 electric motors with 8 ducted fans; 1 connected to each motor. The fuselage is equipped for 4 passengers inclusive of a pilot and luggage stowage. These attributes are some of the key differentiating features compared to common small fixed-wing aircraft or urban helicopters. The ducted fan design not only increases the engine efficiency but also delivers opportunities to reduce the noise footprint of the aircraft, via low blade-tip velocities at Mach numbers below $Ma=0.5$ and the inclusion of acoustic liners which dissipate the blade passing frequency. [43] Also, this design has the capability to be complimented to go into full autonomous mode. This is attributed to a researched market demand for full autonomy in these types of vehicles in the future. This is also a stakeholder requirement. The system supports a total of 3 batteries, 1 for the front canard section and 2 for each wing partition.

It should be noted at this stage, the current propulsion configuration for both the Mistral Air Taxi and the Lilium Jet do not meet the intended design solution definition, which targets satisfying the original stakeholder requirement over the range requirement of 50 miles. Since the proposed design as is does not meet the target requirement, a design change is needed. This is the beginning of the flow of the systems engineering engine, an iterative process to navigate back and forth between the designer and the stakeholder in a goal in fulfilling the original stakeholder needs. The systems engineer is that flow line between those two parties. The Mistral Air Taxi study uses forecasted battery properties, calculating 398 Wh/kg for the wing batteries and 138

Wh/kg for the canard battery pack. [43] The hover power alone required on the Lilium Jet is calculated using the Equation 1.0 [13]:

$$P = \sqrt{\frac{\left(\frac{T}{T_i}\right)^3}{2\rho A}} \quad \text{Equation 1.0 [13]}$$

Where $T_i = 1.26$ is the thrust increase for ducted fans, T is the thrust required or the weight of the vehicle and A is the disk actuator area of the vertical thrust system. Using known weight of the 2-seater configuration at 490 kg and the power requirement of 187 kW just to hover, it was computed that the power requirement for the 5-seater configuration was $P = 1460.386$ kW. This means that this requirement cannot be met alone on the Tesla motors being considered for this design. On a subsystem level, the power can also be broken down per each fan motor. This can be computed using the Equation 2.0 [13]:

$$P = \frac{1}{\eta} \frac{T^{3/2}}{\sqrt{4\sigma\rho A}} \quad \text{Equation 2.0 [13]}$$

Where A is the disk actuator area of the ducted fan, $T = T_{fan} + T_{duct}$ is the thrust generated by the fan and the duct, η the engine efficiency, $\rho = 1.225$ kg/m³ the sea level air density and $\sigma = 1$ is the duct expansion ratio (i.e. ratio of exit area to disk area). [13]

Engines currently are the central performance enabler of an aircraft and are critical to the architectural e-VTOL. The proposed custom hybrid propulsion system design was inspired by Safran's hybrid electric propulsion system [44], however not converting to the use of stacked batteries. In this conceptual distributed hybrid electric propulsion system for aircraft, a turbogenerator (a gas turbine driving an electrical generator) is coupling the power generated by the wing battery component. This combined system powers multiple electric motors turning the ducted fans to provide propulsion. Additionally, each motor controller and motor are connected in series and all 24 sets (motor controllers and motors) are in parallel to each other. This is so

they can all operate on the same voltage levels. The turbogenerator and main wing batteries are powering all of the propulsion while the front battery is powering the avionics package. This was designed this way to ensure that if power loss was experienced from the wing batteries, the front battery will supply as an alternate power source to couple with the turbogenerator in case the pilot needs to glide the aircraft down in the event of an emergency. Additionally, a power distribution unit (PDU) or distribution core was integrated into the design as well to regulate the power drawn from the main wing batteries and the turbogenerator as a redundancy measure in case one of the main wing batteries failed as well.

Another factor in updating a system design is accounting for weights added to the system. In most SE modeling of aircraft, weight is a main system requirement and constraint. [45] In commercial aviation, this is a critical factor as this can affect your performance metrics. If we assume the turbogenerator pack is a substantial weight, this will ultimately add to the design gross weight (DGW) affecting the mission range it can perform. Meaning, if the powerplant selection at this point has been made, now the process of confirming this still satisfies with the Level 1 requirement of flying 50 miles must occur. This often is an iterative process, which MBSE can assist in streamlining. Weight calculations are a mandatory step in aircraft design as there are inherent safety factors to consider and are mandated by the FARs. Below in Figure 36.0, is a depiction of how to classify the different weight categories. This is important as this clarifies the difference between the maximum payload weight and the maximum design takeoff weight, the maximum payload weight (1200 lbs.) being a flight mission requirement annotated earlier in Section 3.2. In Figure 37.0, is a depiction of the relationship between the payload weight and the range. Figure 37.0 provides a visual correlation to how adding weight to the

design gross weight impacts the ability to satisfy another flight mission requirement, which is the mission range.

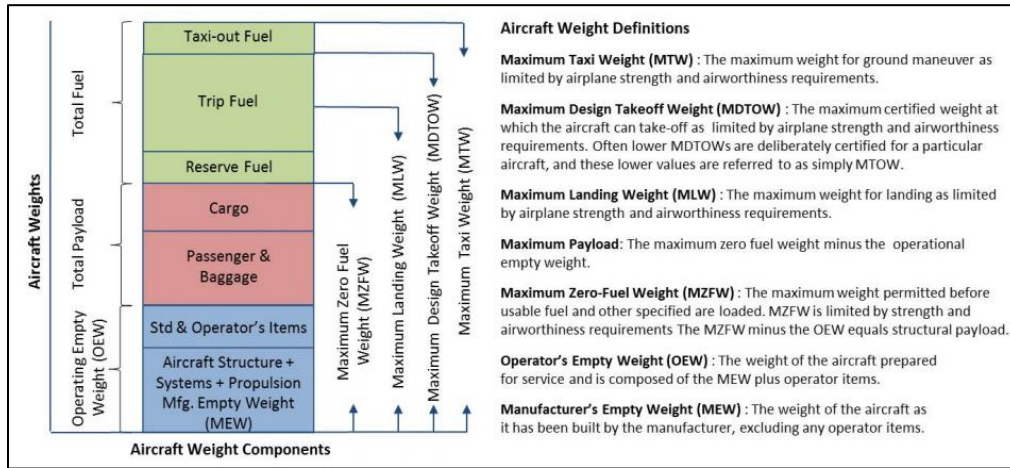

Figure 36.0: Composition of Weight Categories [45]

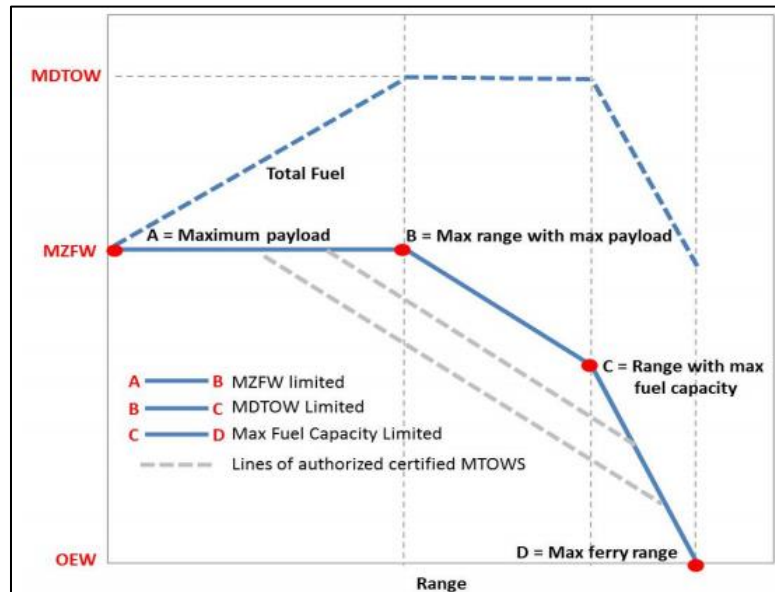

Figure 37.0: Typical Payload and Range Diagram [45]

Below in Figure 38.0, is a depiction of how a system/subsystem (in this case manufacturer's empty weight) requirements relate to original mission objectives. As illustrated in this sysML diagram, the requirement for MEW is not an established flight mission requirement. Rather its traceability comes from a "notional" Part 29 helicopter requirement tracing back to the

FARs to just illustrate an example of the traceability if actual FARs existed for UAM vehicles. If FARs did actually exist, then my system requirements would not just satisfy but would trace back to them. Additionally, the flight mission requirements must directly satisfy the primary objective to perform a flight mission with a UAM vehicle for passenger transport. However, the flight mission requirements must still satisfy the FARs, from which this “notional” Part 29.29 requirement traces to.

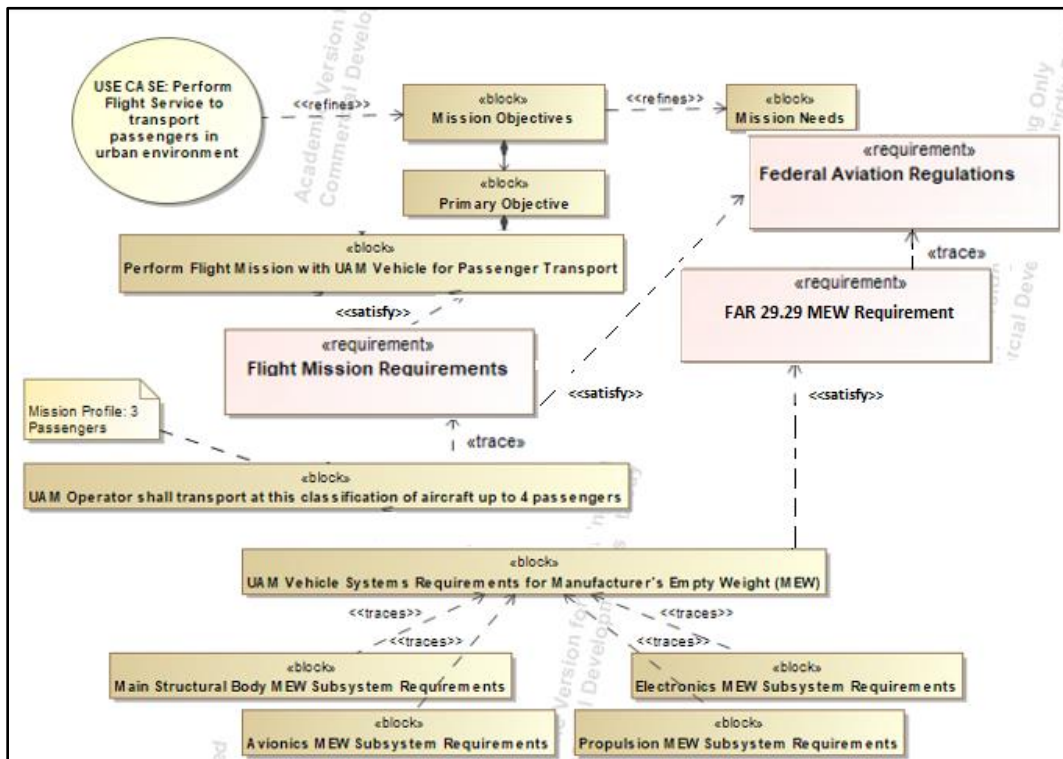

Figure 38.0: MEW Systems Requirements in Relation to a Mission Objective

For the design in question, the next stage would be to break down the entire aircraft down into logical subsystems. These subsystems are: (1) main structural body, (2) propulsion, (3) electronics, and (4) avionics. Modeling structure subsystems requires the usage of BDDs and IBDs. [28] At the top of the BDD is “UAM Vehicle” in Figure 39.0, further breaking down into its logical subsystems. In this BDD, the subsystems are represented as blocks that trace back to the high-level system, the “UAM Vehicle”. [28] The goal of creating BDDs is to capture the

static structural framework recursively containing and decomposing its elements, the contents inside those elements (nested elements), and the types of interfaces associated. An example of nested elements is depicted in both Figure 39.0 and Figure 40.0.

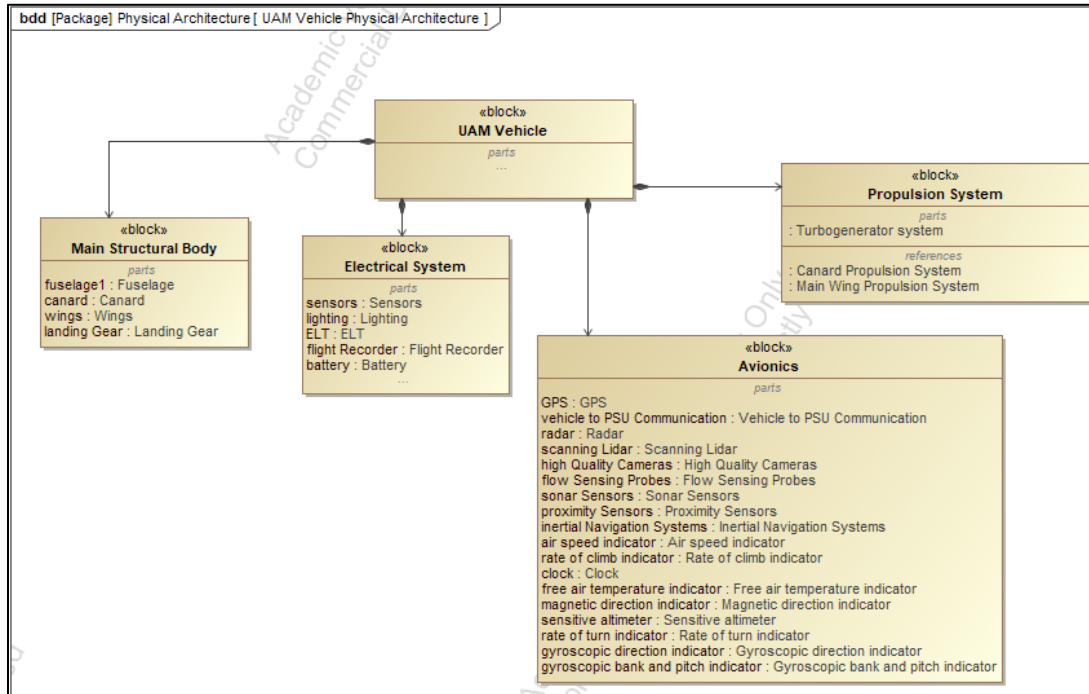

Figure 39.0: Block Definition Diagram of UAM Vehicle System

As shown in Figure 40.0, the main structural body block is further decomposed into (1) fuselage, (2) canard, (3) wings, and (4) landing gear. If you select the “Main Structural Body” block in Figure 39.0, it forwards the end user in the SysML environment to Figure 40.0, where there is another BDD displaying all of the contents (inclusive of properties, behaviors, and constraints) for that particular subsystem. This enables the reconstruction and later, re-design of the subsystems under scrutiny and assists in collaborative efforts. Elements in Figure 40.0 are quantified as “parts”, defined by blocks, if they contain internal block diagram information. An element’s specific definition is a block, while the use case of an element within certain context should be classified as a part. It is at the discretion of the end user to quantify the decomposition of a subsystem either by a series of block definition diagrams or by internal block definition

diagrams, or a combination of both. Reusable descriptions, provided by blocks, can also be applied to conceptual aspects of the system design. [28]

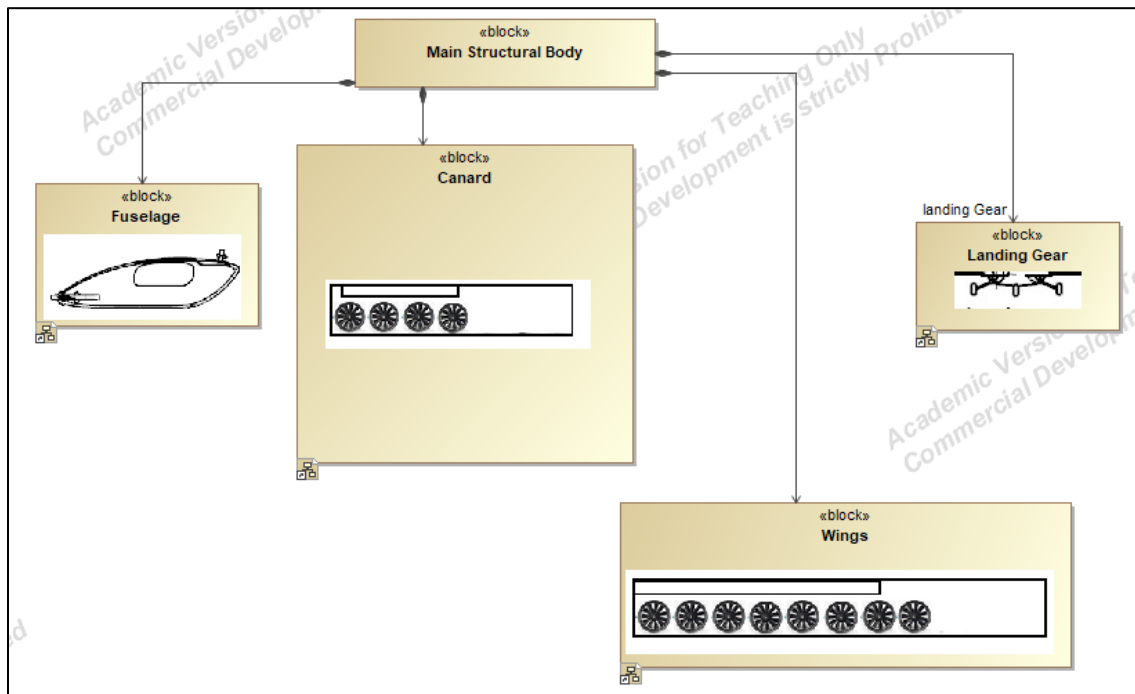

Figure 40.0: Block Definition Diagram of the Main Structural Body

In this MBSE model, if “Fuselage” is selected in Figure 40.0, it would forward to Figure 41.0, which is a breakdown of the elements contained inside this block. Figure 41.0 depicts the components needed to provide structural integrity for the fuselage needed for this proposed design. For this design, the aircraft breaks down into several logical sub-components such as the frame, the skins, the interior separation panels, the doors, the seats, the interior flooring, the windshield, and the side windows. As shown in this figure, certain sub-components break down even further as the case for the cockpit dashboard. The cockpit dashboard decomposes into the heads-up display (HUD), the joystick and all the gauges. Similarly, the “Seats” block breaks down between the pilot’s seat and the passenger’s seats.

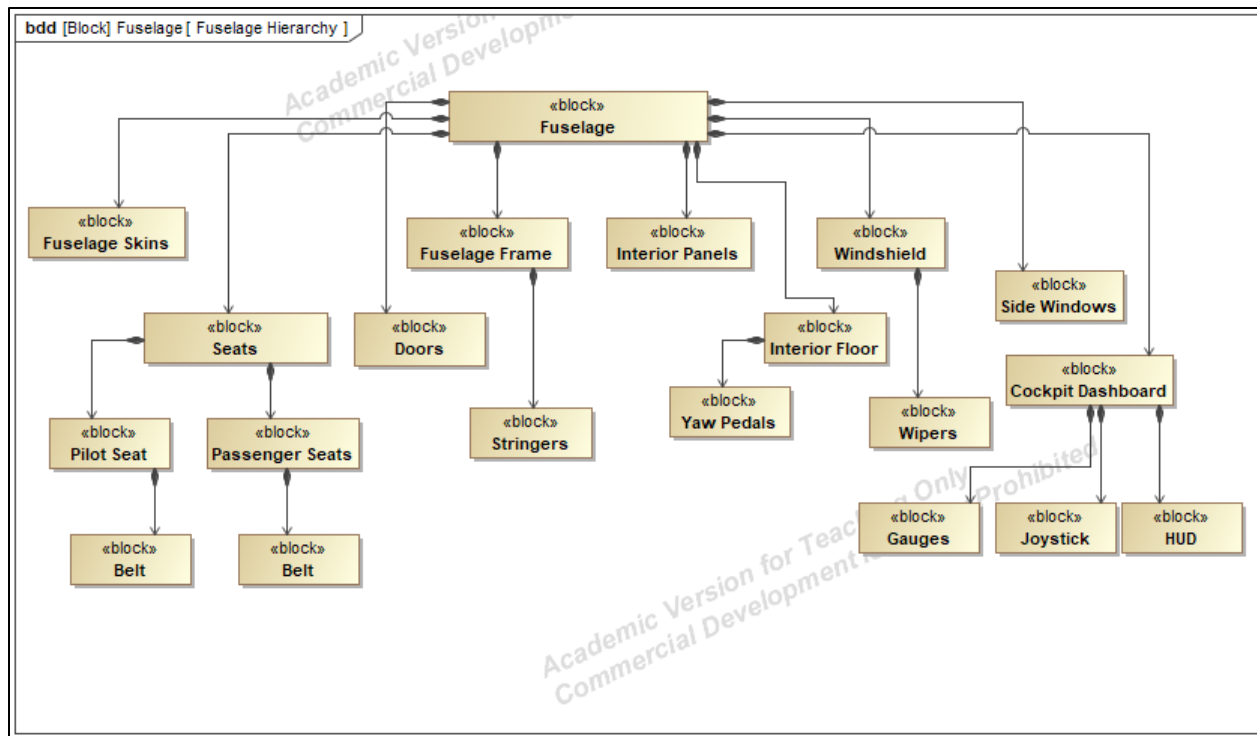

Figure 41.0: Block Definition Diagram of the Fuselage System

The BDD depicted in Figure 42.0 is a further decomposition of the propulsion system, a critical subsystem of the UAM vehicle (Figure 39.0). It is shown through this BDD that the propulsion system consists of the tilt wing ducted fan system, adjoining motors, and controllers needed for maneuvering the UAM vehicle. The propulsion system is decomposed into a main propulsion system associated with the wings, and the canard propulsion system in the front of the UAM vehicle. The main propulsion system in the wings draws battery power from a battery source other than the canard propulsive element. Additionally, the battery source powering the motor controllers is not a direct connection but is connected through the power supply unit. This sends a signal to the UAM vehicle flight computer, which sends a signal to the motor controllers to regulate the voltage to the electric motors to drive the ducted fans. The ducted fans in turn provide the thrust needed to lift the aircraft off the ground. The canard inter-connectivity follows a similar scheme but is not connected to the tilt mechanism.

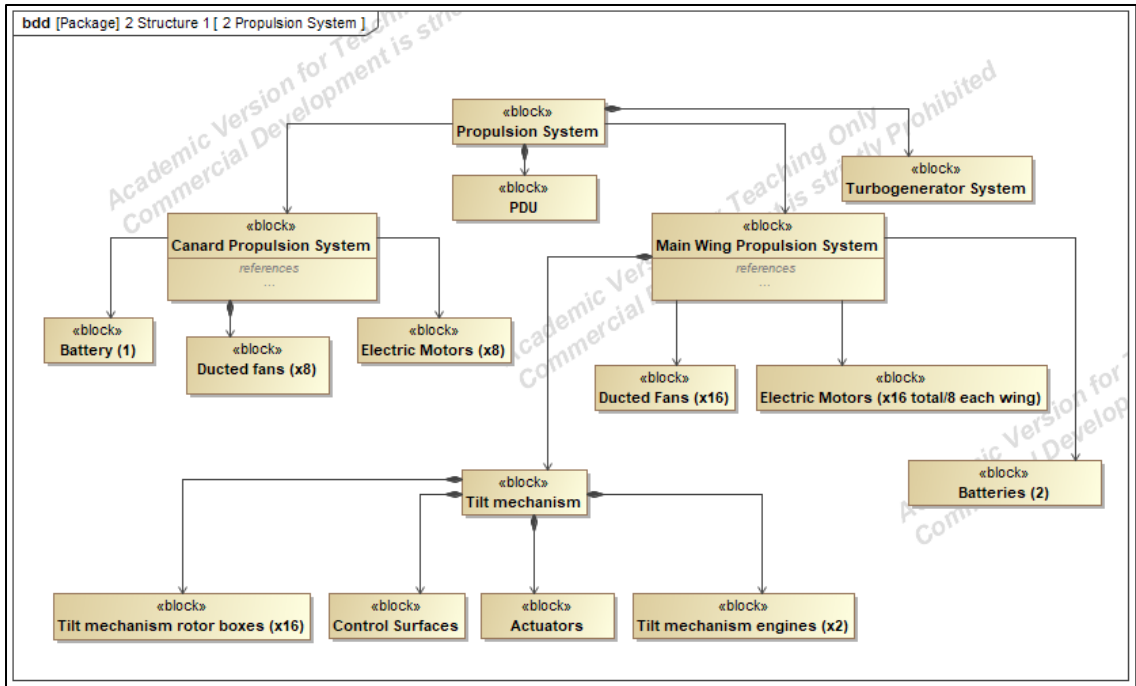

Figure 42.0: Block Definition Diagram of the Propulsion System

The next type of structural diagram is the internal block diagram and provides a more “white box” internal examination into the component in question. [28] An IBD can be used to display an entire system architecture and how each subsystem is connected to the system (as a whole) as shown in Figure 43.0. In Figure 43.0, the connectivity between the four main subsystems (electrical, avionics, propulsion and structural) is showcased. In this design, it is shown that the left-wing and right-wing batteries are connected through the power distribution unit (PDU) to service the propulsion subsystem. The front battery does not connect with the PDU but connects directly with the flight computer/central processing unit (CPU) to power the avionics package. Because of this functionality, the front battery is stationed in the front of the fuselage next to the avionics package. This is an example of how an internal block diagram is used to focus on the connectivity of a subsystem to provide further analytical detail to help streamline structural design. Additional details include properties so that its values, parts, and references to other blocks can be specified. An internal block diagram created for a block

includes parts, connectors, and ports. [28] As demonstrated in Figure 43.0, two ports connect the tilt actuator assembly to the control surfaces, which fall under a completely different subsystem, the structural subsystem. However, two ports within the same subsystem can be connected, as evident by the CPU connecting to the avionics package, which all falls under the avionics subsystem. An IBD created for a package diagram includes additional elements (shapes, notes, and comments). The block in the diagram heading broadcasts the context of that diagram. Connecters can connect either to ports on various parts, or from part to part directly. All ports on a block serve as interaction points, inclusive if the block represents a part. Parts can also include part properties. This is a property that specifies a part with strong ownership and describes a local usage or a role of the typing block in the context of the containing block. From the high-level conceptual design in the MBSE approach, more comprehensive schematics can be produced as illustrated in Figure 44.0, which is a detailed technical schematic derived from the MBSE version in Figure 43.0. This technical schematic color-codes the flow lines from each of the subsystems to provide clearer design intent.

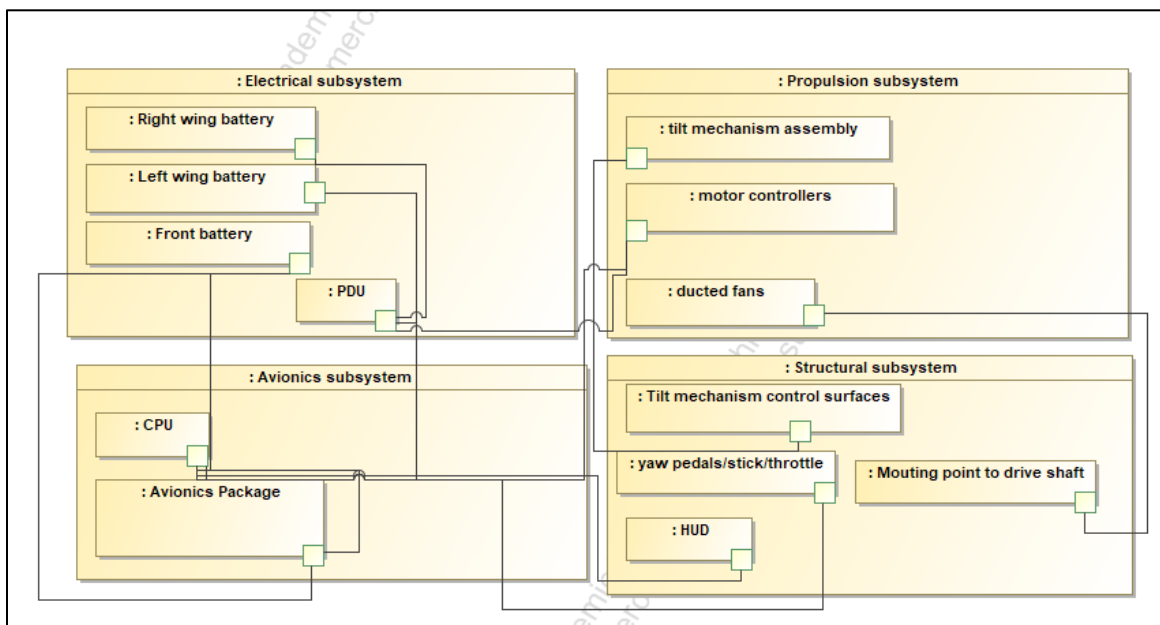

Figure 43.0: Internal Block Diagram of the UAM Vehicle System Interfaces

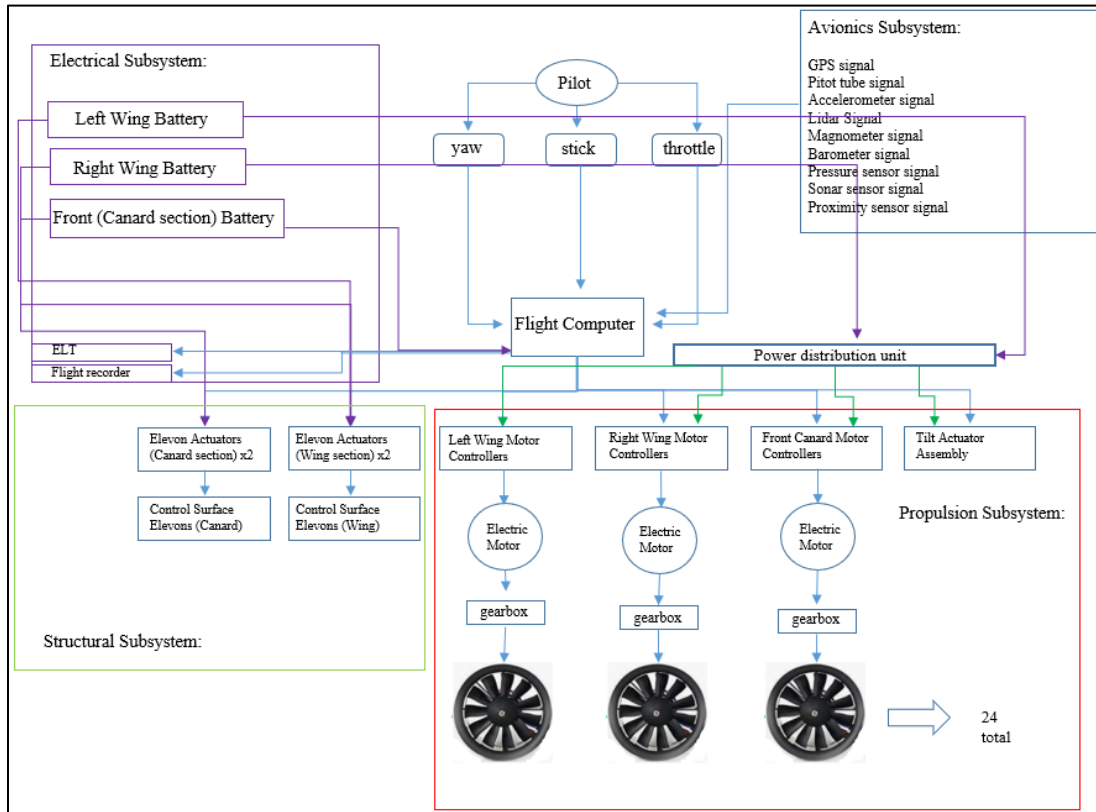

Figure 44.0: Detailed Comprehensive Subsystems Schematic

The proposed design for the propulsion system is shown as an IBD in Figure 45.0. As indicated earlier, this design is a hybrid configuration e-VTOL aircraft, not a fully electric configuration. In Figure 45.0, the turbogenerator component is added to the propulsion subsystem design inclusive of its model connectivity to the other subsystems. The turbogenerator component connects with the electrical subsystem through the PDU to supplement the left-/right-wing batteries for the power requirement needed in this design. The subsequent detailed schematic derived from the MBSE version is shown in Figure 46.0. In this technical schematic, further detail is provided about the turbogenerator component. This shows the need for a fuel supply component to service the turbine engine, which is part of the turbogenerator assembly.

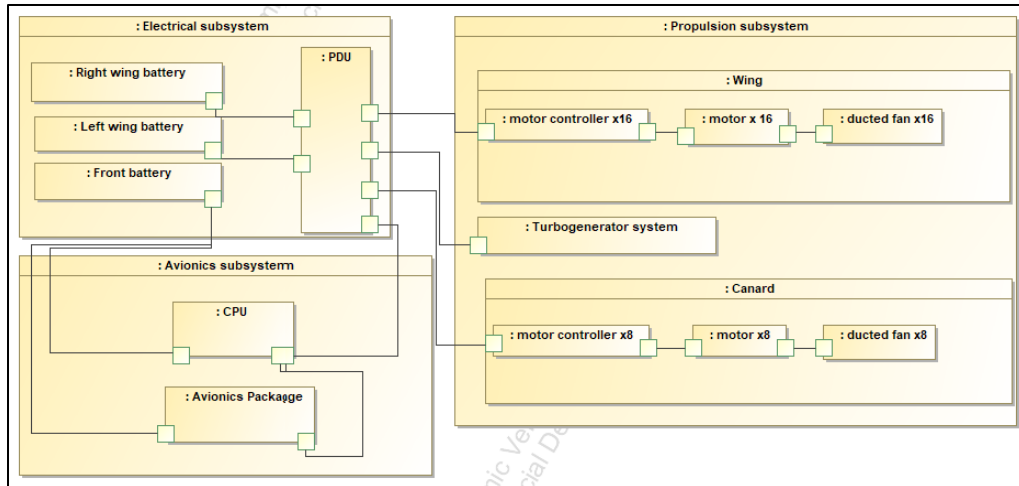

Figure 45.0: Internal Block Diagram of the Propulsion System

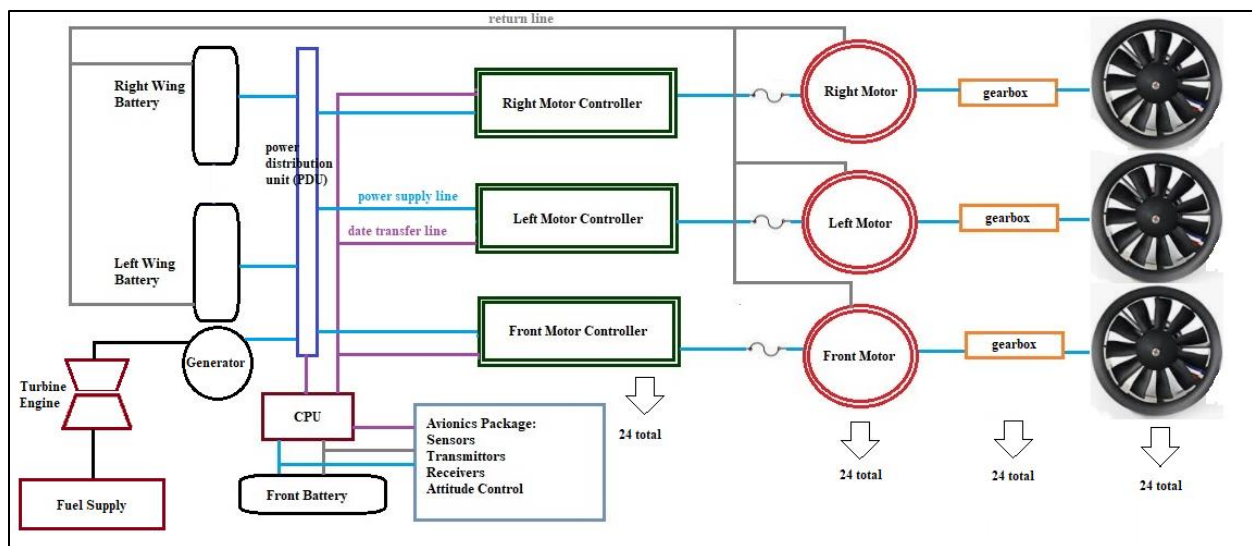
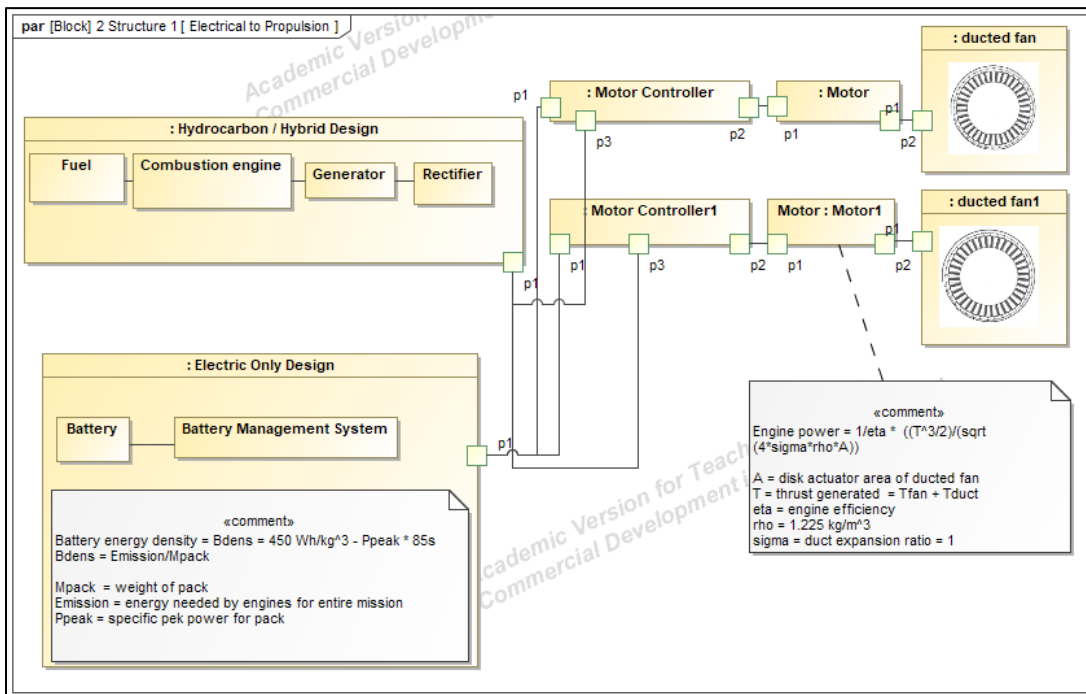

Figure 46.0: Detailed Schematic of Propulsion System Proposed

3.9 PARAMETRIC MODELING

Traditionally in support of the analysis context of the SysML model, is the creation of what is called a parametric diagram. As a specialized type of an IBD, a parametric diagram depicts the mathematical relationships inherent in that part of the system. In fact, mathematical

rules and parameters are contained inside constraint blocks, of which the parameters are tied into the block value properties. [28] The actual purpose of these diagrams is to enforce these mathematical rules across block value properties. Constraint block parameters are interwoven by binding connectors (each having at least one end connected to a constraint parameter) and the internal part value properties effect the constraint satisfaction. As shown in Figure 47.0, the primary focus is the demonstrate the connective relationship from the electrical system to the propulsion system and the associated parametrics within each subsystem. The hydrocarbon fuel/hybrid propulsive element was incorporated into this parametric diagram to show how that subsystem would be integrated into the design. Certain elements such as the flight computer and the PSU were intentionally omitted from this diagram as the main intent was to focus on the mathematical rules governing the battery system and the engine power output. The parametric equations used were defined in [43].



**Figure 47.0: Parametric Diagram of Electrical to Propulsion Connection
 With the Addition of the Turbogenerator System**

Requirement traceability is one of the fundamental features of the MBSE approach. This is demonstrated in Figure 48.0, where an air speed indicator traces to a FAR requirement. Of note, FAR 29.1303 was used as a “notional” requirement to demonstrate a concept. The FAR specifies the flight and navigation instruments that must be on this category of aircraft. The airspeed indicator is listed as a needed instrument for the system requirement. An additional subsystem requirement for the performance of the airspeed indicator is subsequently shown as well. (Note: The requirement for the instrument range was added as 0-120 knots to provide a measurable requirement). In this parametric diagram, a functional schematic of an air speed indicator with its associated parametric equations are included in the airspeed indicator, inside the avionics package. As shown, the avionics package is connected to the CPU and the front battery (acting power source). This figure distinctly shows how a subsystem parametric model traces back to level 2 system requirement.

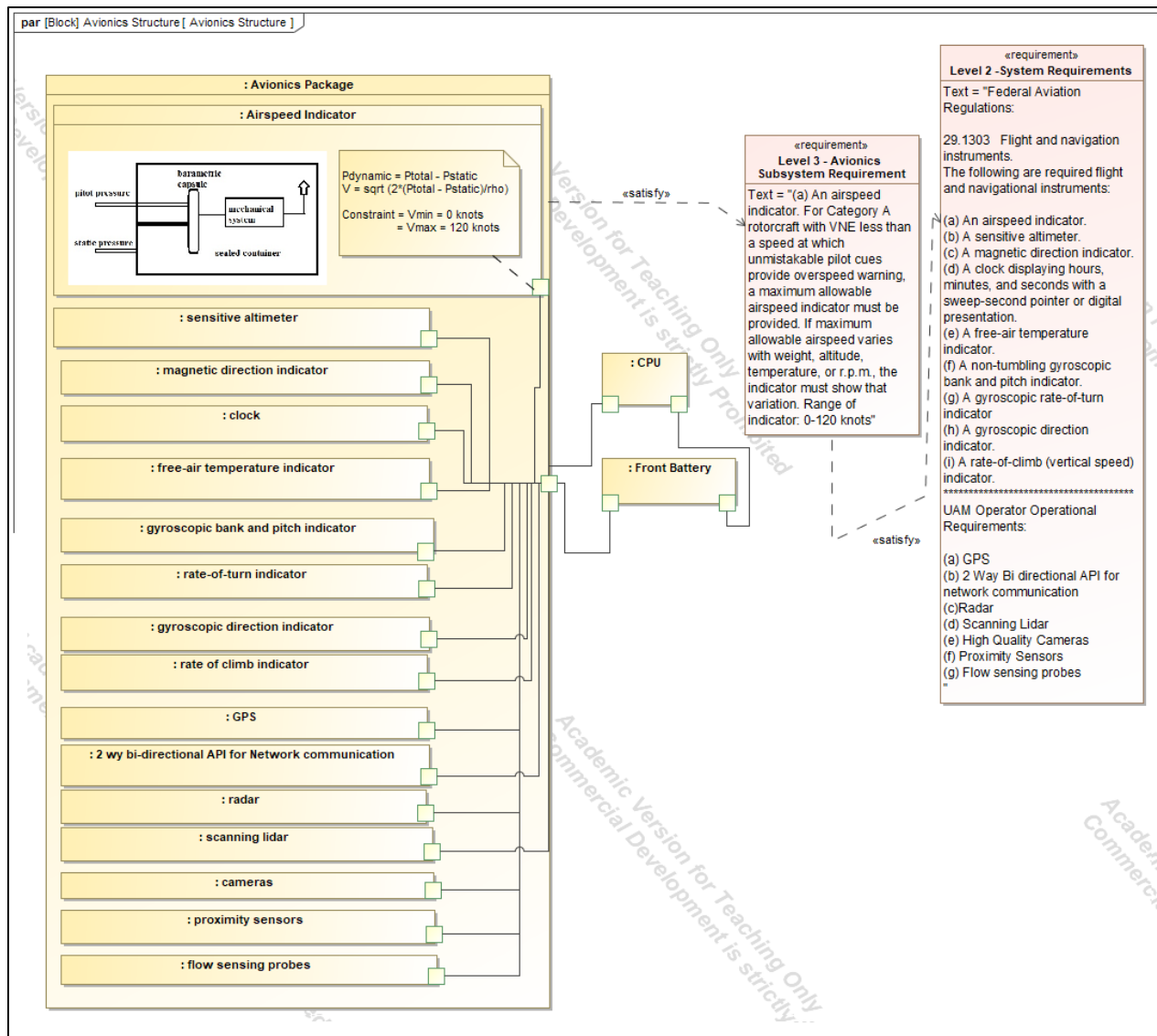

Figure 48.0: Traceability of a Subsystems Requirement to the Requirement Authority

CHAPTER 4 – ANALYSIS: ANALYZING THE SYSML MODEL

4.1 SYSML MODEL ANALYSIS

4.1.1 MBSE APPROCH TO COMPLETELY ELECTRIC E-VTOL FEASIBILITY

To discern whether a fully electric e-VTOL configuration is feasible, an MBSE approach will be used to prove this cannot be accomplished with current technology. Per the flight mission requirements specified in Section 3.2, there is a customer request to travel 50 miles to reach the destination vertiport landing site. Per reference [29], for this flight mission parameter (flight range) specified, it would take a minimum power requirement of ~300 Wh/kg, which is a forecasted technology achievement by 2026. With the current technology level at 150 Wh/kg, the battery component listed under the electrical subsystem in Figure 49.0 would not be able to satisfy the customer requirement of 50 miles. If additional battery packages were added to the supplement the design, this would ultimately add further weight to the vehicle, which will then affect the ability to satisfy the flight mission range requirement once again.

To demonstrate through calculation why the current battery specific energy capacity would not satisfy the flight mission requirement of 50 miles, the 5-seater Lilium Jet (which is a close approximation to this paper's design) listed in reference [13] will be used as a case example. Per the equations listed in reference [46], and the aircraft computed known parameters in reference [13] for the Lilium Jet, the aircraft maximum energy and the flight range can be computed. From reference [46], the two equations needed are:

$$E = E^* * m_{battery} * \eta_{total} \quad \text{Equation 3.0 [46]}$$

$$R = E^* * \left(\frac{m_{battery}}{m}\right) * \left(\frac{1}{g}\right) * \left(\frac{L}{D}\right) * (\eta_{total}) \quad \text{Equation 4.0 [46]}$$

Where E = the amount of electrical energy an aircraft can store and use as a function of battery specific energy (E^*), battery mass ($m_{battery}$) and total propulsion efficiency (η_{total}).

[46] In Equation 4.0, R = range, m = total mass of aircraft, g = gravity constant of 9.8 m/s^2 , and $\frac{L}{D}$ is the lift to drag ratio. From reference, taking known values for the 5-seater Lilium Jet, $E^* = 157 \text{ Wh/kg}$, $m_{battery} = 900 \text{ kg}$, $m = 1700 \text{ kg}$, $\eta_{total} = 70 \%$. Per reference [13], it is assumed the lift to drag ratio is ~ 41 which is too high for this type of aircraft, so a lift to drag ratio of $5 - 9$ was used per reference [47]. This will also help to provide a general range this aircraft can perform. An additional weight for the turbogenerator is also considered in this calculation to show how adding additional weight affects flight range. Since it is not listed what this weight would be per reference [13], the weight of a PT6B-36B helicopter turboshaft engine per reference [48] is used to approximate this additional weight. The turboshaft engine weight is 171.458 kg (378 lbs.). [48] From equation 1.0, it can now be computed that:

$$E = E^* * m_{battery} * \eta_{total}$$

$$E = \left(157 \frac{Wh}{kg}\right) * (900 \text{ kg}) * (0.70)$$

$$E = 98,910 \text{ Joules} = 98.910 \text{ kJ}$$

And computing range without the additional turboshaft engine weight included:

$$R = \left(157 \frac{Wh}{kg}\right) * \left(\frac{900 \text{ kg}}{1700 \text{ kg}}\right) * \left(\frac{1}{9.8 \frac{m}{s^2}}\right) * (5) * (0.70)$$

$$R = 29.684 \text{ km} = 18.445 \text{ miles for } \frac{L}{D} = 5$$

and

$$R = 54.432 \text{ km} = 33.822 \text{ miles for } \frac{L}{D} = 9$$

To show how adding the additional turboshaft engine weight would affect the flight range, the following is computed:

$$R = \left(157 \frac{Wh}{kg}\right) * \left(\frac{900 kg}{171.458 kg + 1700 kg}\right) * \left(\frac{1}{9.8 \frac{m}{s^2}}\right) * (5) * (0.70)$$

$$R = 26.965 km = 16.755 miles \text{ for } \frac{L}{D} = 5$$

and

$$R = 48.537 km = 30.15949356 miles \text{ for } \frac{L}{D} = 9$$

As computed, the above calculations prove that with the current battery specific energy listed at 157 Wh/kg, the flight range would fall somewhere between approximately 17- 34 miles and not be able to support 50 miles. Of additional note, the total propulsion efficiency of 70% computed in reference [13], takes into account, a propulsion system that does not operate on exclusively battery technology. If this design were a fully electric design, the flight range would significantly decrease because the total propulsion efficiency for a fully electric design would also decrease. To be able to achieve a 50-mile (80.467 km) mission, by use of equation 4.0 again, the following calculations indicate what range the battery specific energy would need to be. Not including the turboshaft engine weight, E^* is computed at:

$$80.467 km = (E^*) * \left(\frac{900 kg}{1700 kg}\right) * \left(\frac{1}{9.8 \frac{m}{s^2}}\right) * (5) * (0.70)$$

$$E^* = 425.593 \frac{Wh}{kg} \text{ for } \frac{L}{D} = 5$$

and

$$E^* = 236.433 \frac{Wh}{kg} \text{ for } \frac{L}{D} = 9$$

And including the turboshaft engine weight, E^* is computed at:

$$80.467 \text{ km} = (E^*) * \left(\frac{900 \text{ kg}}{171.458 \text{ kg} + 1700 \text{ kg}} \right) * \left(\frac{1}{9.8 \frac{\text{m}}{\text{s}^2}} \right) * (5) * (0.70)$$

$$E^* = 486.504 \frac{\text{Wh}}{\text{kg}} \text{ for } \frac{L}{D} = 5$$

and

$$E^* = 260.284 \frac{\text{Wh}}{\text{kg}} \text{ for } \frac{L}{D} = 9$$

These calculated values support the information provided from the Section 1.4 stating that battery technology would need to be in the range between 250 – 300 Wh/kg to support these types of flight missions.

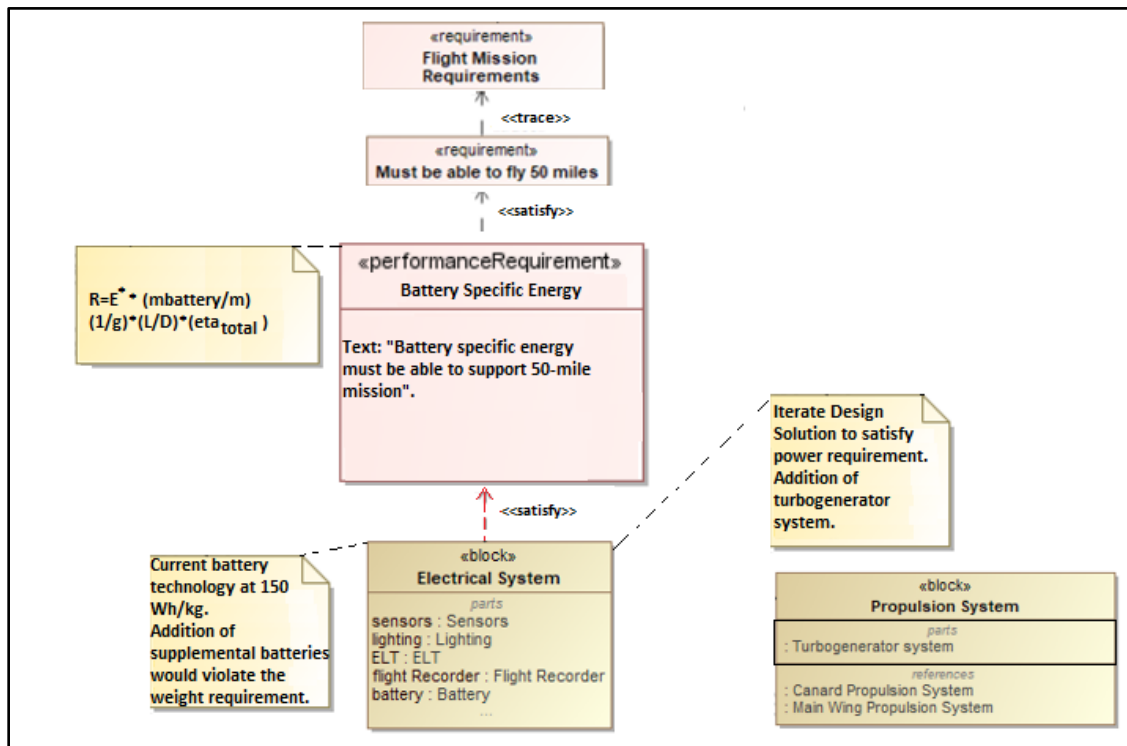

Figure 49.0: Feasibility of an All-Electric Design through MBSE

4.1.2 TECHNICAL DECISION ANALYSIS FOR A PROPOSED DESIGN SOLUTION

To evaluate the benefit of MBSE as a tool to analyze and improve a UAM aircraft design, a simple baseline model was needed to provide logical decomposition for the MBSE model. To derive this baseline model, a technical decision analysis was conducted by comparing publicly available information about UAM aircraft currently in production or development. In following the technical process as outlined in ref [1], [32], and [33], it is important to address early concept and technology development that will translate into preliminary design efforts. [1] As there are several different configurations of VTOL/e-VTOL aircraft to examine, whichever configuration is preferred, this configuration will then follow more closely Federal Aviation Regulations (FARs) for either fixed wing aircraft or for helicopters. In some stages of flight, both fixed wing and helicopter FARs would be applicable. Currently, there are no finalized FARs for UAM Aircraft. This study shows that the preferred reference design would follow helicopter FARs more than fixed wing.

Several concept UAM vehicles have been studied in the last ten years. To draw a comparative basis, different configurations were examined and how each configuration performs in similar flight missions. In determining what would be the most optimal design for the flight mission requirements specified in Section 3.2, a simple trade study is performed to analyze configuration suitability. To perform a basic design solution study, the NASA Decision Analysis Process [1] is used as a guideline, which is partially based on the Pugh Method for decision-making. [49][50] Further refining of a traditional trade study can include defining evaluation criteria, defining weight factors, defining a normalization scale, and then the ranking of the solutions.

Sometimes, derived initial solutions may seem misleading at first. For example, in study performed in “Electric VTOL Configurations Comparison” paper [13], a multirotor E-Hang

design performed better at executing hover maneuvers but cannot satisfy the range requirements of a 100 km mission. The vectored thrust design has a higher cruise efficiency, but in the 2-seat configuration cannot support the range requirements. When a problem has multiple solutions, a study could rank the solutions by giving each solution a numerical value. Next, the study shall determine a numerical value for each option. This is often done based on weight factors and a normalization scale for the evaluation criteria. Evaluation criteria are key factors that should be included. Weight factors can be used to dictate how important the evaluation criteria are relative to each other. The normalization scale creates a constant interval scale that allows us to set a numerical value for each of the evaluation criteria. [49] From the configurations examined, the closest design that met the mission criteria (that is not a simulated design) would be the 5-seat configuration Lilium Jet design that has a maximum range of 186 miles, a maximum payload weight of 3248 lbs., and a cruise speed of 156 m/hr. [13] The NDARC simulated designs were next considered. [25] Next, each parameter was weighted on the level of importance relating to the flight mission, which was then examined if that parameter was even met. The last step was examining the best elements of each design and deriving the optimal hybrid design. It was concluded a ducted fan design solution met the stakeholder needs. Figure 50.0 below depicts the design solution study that was performed.

		occupancy (PAX)	parameter weight	satisfies	max payload weight	parameter weight	satisfies	empty weight (lbs)	net weight (lbs)	Range (m)
	Multicopter (E-Hang)									
	current configuration	2	5	No	485.017	5	No	370.377	573.202	21.74
	Lift + Cruise (Kitty Hawk Cora)									
	current configuration	2	5	No	399.037	5	No	185.963	585	62.13
	Vectored Thrust (Lilium)									
	lite configuration	2	5	No	580.27	5	No	500	1080.27	53.73
Baseline	heavy configuration	5	5	Yes	3247.858	5	Yes	500	3747.858	186.411
not elec	Quadrotor Turboshaft									
	current configuration	6	5	Yes	1200	5	Yes	2345	3735	75
	Quadrotor Electric									
	current configuration	6	5	Yes	1200	5	Yes	5270	6480	75
not elec	Side by Side Turboshaft									
	current configuration	6	5	Yes	1200	5	Yes	2111	3468	75
	Side by Side Electric									
	current configuration	6	5	Yes	1200	5	Yes	3687	4897	75

Figure 50.0: Design Solution Study Conducted for UAM Configuration

Taking from the results concluded from the design solution study, the ducted fan design was deemed the most preferable. The quadrotor design did not suffice for the mission requirements as typically this type of aircraft require a lot more power compared to fixed wing aircraft, as it needs more power to overcome both the weight and drag components. [13] Due to the stakeholder requirements for the UAM vehicle, there is going to be a hover phase of the flight plan. This phase of flight that generally uses more power than the cruise phase for a fixed wing aircraft. Regardless of design, there will be a hover phase, in which the power is drawn most from the propulsion system. Looking at the whole flight mission, regarding the cruise phase, one can design something that is more efficient. The thrust vectoring concept design enjoys some of the aerodynamical efficiencies of fixed wing aircraft. With a ducted fan configuration, the higher disc load of the architecture, more power is required during the take-off phase. The proposed design does not require a change in the location of the electronics/battery subsystems. In keeping with the original design, the elevons were kept on both the canard section and on the main wings.

4.1.3 SATISFYING UAM OPERATOR OPERATIONAL REQUIREMENTS

One of the key model artifacts produced is the ability to exhibit how subsystems from the physical architecture satisfy UAM operator/operational mission requirements. A requirement diagram is the best way to make the derived requirement traceability transparent to all end users. [28] Relationships are defined as either satisfaction, derivation, verification, refinement, or trace in the SysML environment. In Figure 51.0 and Figure 52.0, a demonstration of this capability is depicted displaying the traceability of a requirement to the actual system structural hardware. For instance, the requirement for a bi-directional API onboard the aircraft to support network

communication is fulfilled via the accuracy and range of the avionics hardware by annotating the <<satisfy>> relationship. Additionally, the operational requirement (which the customer requirement must fall in line with), of the mission range is satisfied not only by the onboard electrical system inclusive of the battery technology, but by the propulsion system as well. As shown in Figure 51.0 and 52.0, the propulsion system must now satisfy the mission range, the mission payload, the noise reduction requirement, the energy storage requirement, the reserve capacity requirement, and the vehicle movement requirement. The avionics system must provide support to satisfy the network communications, the security technology, the vertiport infrastructure data exchange requirements, and the detect and avoid (of other aircraft) requirements. The main structural body must be able to satisfy the requirements needed for the mission payload and the operational intent needed for flying within the vertiport infrastructure. Of additional note regarding these two figures, is the direct correlation of how many of the flight mission parameters listed in Section 3.2 are in congruence with the operational requirements needed at the operator level. This implies that a customer cannot request a flight to travel 50 miles if the UAM operator is not originally capable of doing so.

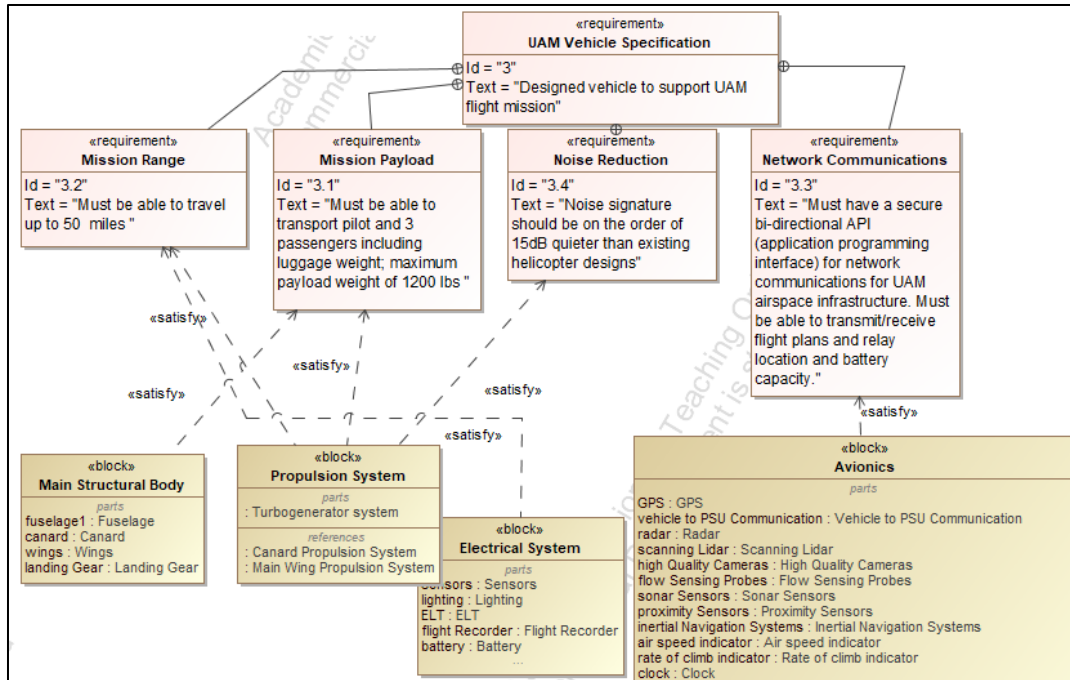

Figure 51.0: Requirements Diagram for Refined Mission Requirements (Part 1)

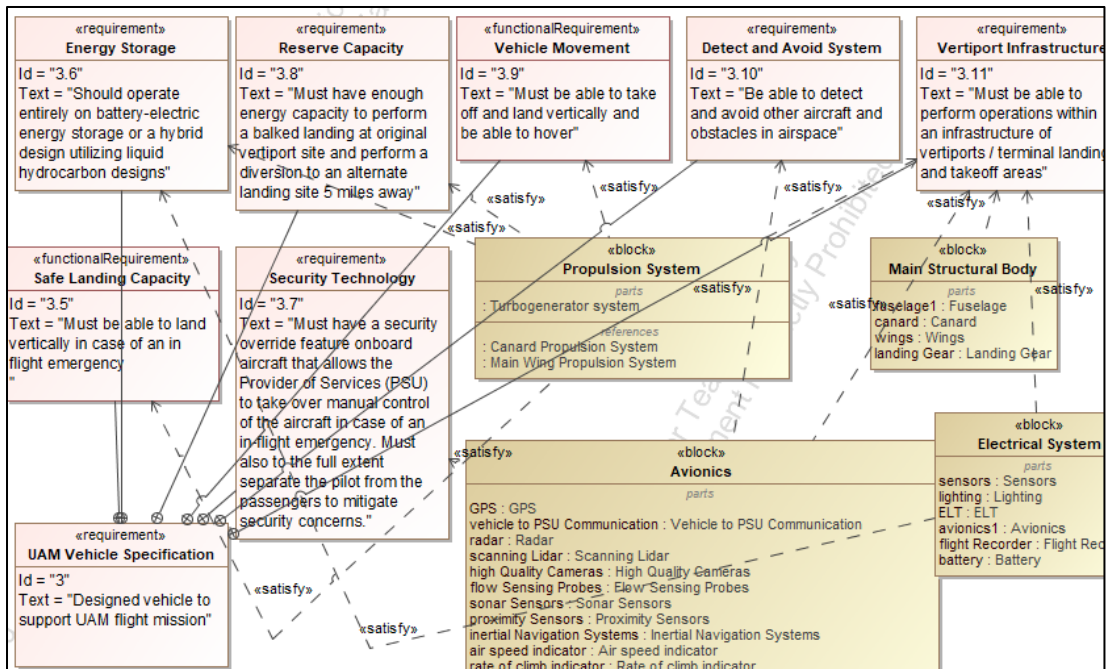

Figure 52.0: Requirements Diagram for Refined Mission Requirements (Part 2)

Another important tool utilized for this effort, is the ability to assert what system (or mission) requirements are derived from the stakeholder needs. [28] This is demonstrated in Figure 53.0 by use of a “derive requirement” matrix. The rows represent the named elements which can be the client element of derive dependency. The columns represent requirement element which can be the supplier element of derive dependency. For this requirement diagram, the UAM Operator Operational requirements are listed as the row data and the requirements from the FAA NextGen ConOps are listed as the column data. This type of matrix can aptly show how operational requirements are derived from the Level 1 FAA NextGen UAM ConOps requirements through a selected traceability relationship type. This is a good way to ensure your requirements are in congruence with the stakeholder needs.

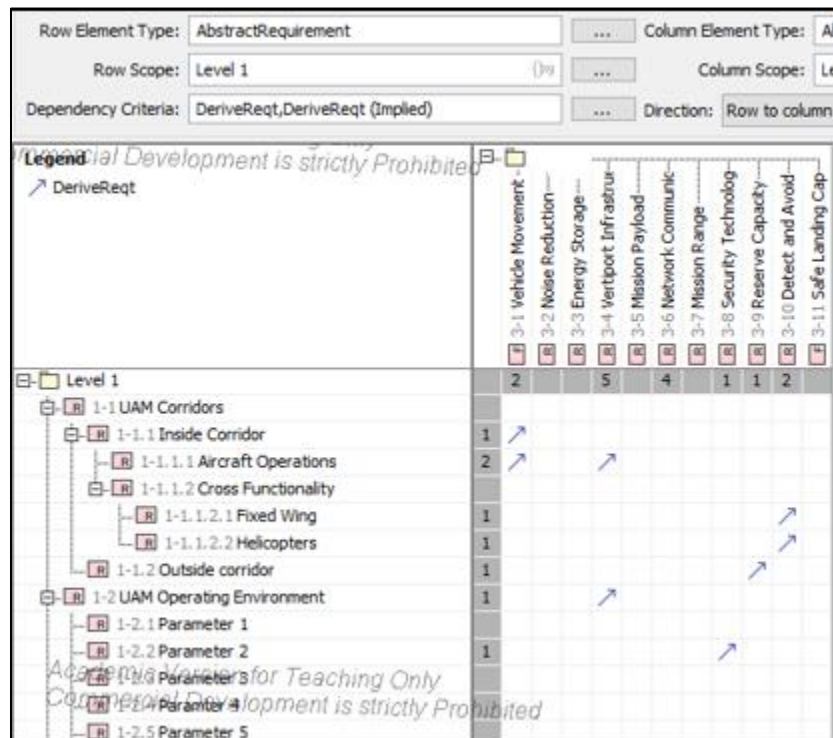

Figure 53.0: UAM Operator Requirements to Stakeholder Needs “Derive Requirement” Matrix

Model artifacts must be supported by the project milestones. A requirements matrix is sufficient in specifying this level of support. [28] Figure 54.0 depicts this type of matrix.

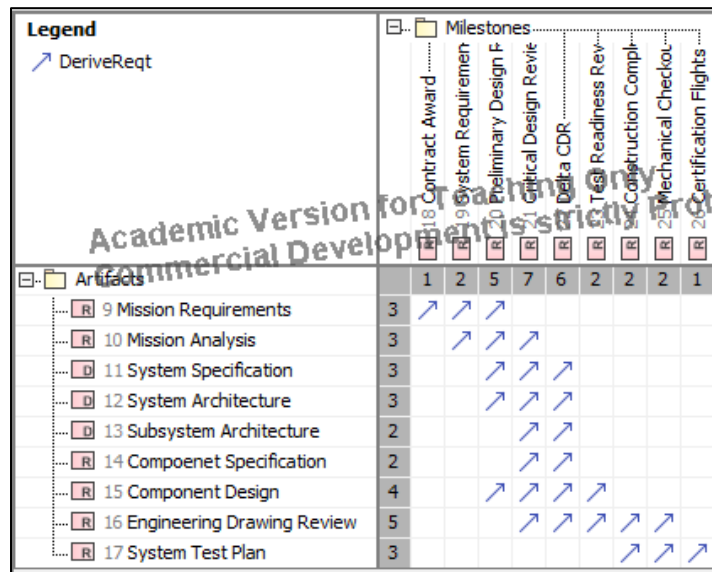

Figure 54.0: Artifacts versus Milestones Requirement Matrix

When it comes to modeling in SysML and working within the systems engineering engine, verification testing is imperative. Test cases are used to achieve the verification objectives and to ensure you are verifying requirements. [28] Test cases are administered for each subcomponent on a pass/fail criterion. Figure 55.0 depicts a BDD for the Verification Domain tracing down to the battery subcomponent to help demonstrate this concept. As shown in Figure 55.0, verification testing occurs at the lowest sub-component level for the batteries (and individually the front, left and right-wing batteries) which fall under the electrical subsystem. Likewise, there is verification testing performed at the electrical system level and finally at the full aircraft assembly level. After verification testing has been completed, this will lead into final validation of the aircraft assembly design.

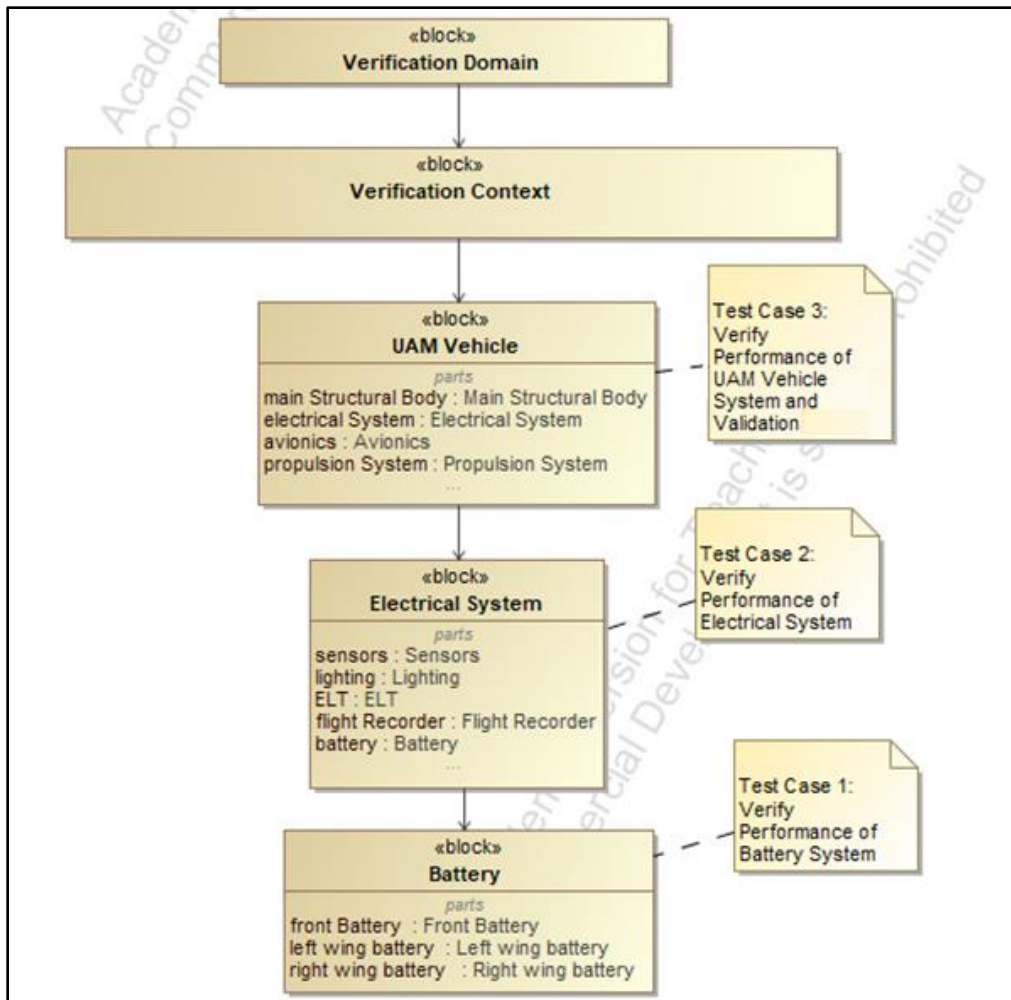

Figure 55.0: SysML Diagram of the Verification Domain

4.2 MODELING OFF-NOMINAL FLIGHT SCENARIOS USING BEHAVIOR

MODELING

In the effort of informing developing procedures for this airspace infrastructure UAM vehicles are intended to fly in; another element of the SysML model was created. For this model, a new package titled “Off-Nominal Scenarios” was created under the behavior model hierarchy. In an ideal mission design, the flight will be executed without incident. However, in respect to contriving realistic designs, contingency management of off-nominal events must be addressed.

A good example of this would be a mission that has the vehicle route towards a destination that may experience heavy incoming traffic and require the vehicle to reroute to another landing site. The need of a reroute, as shown in Figure 56.0, to an alternate landing site would instantiate a requirement for the reserve capacity to meet the distance requirements set forth by the actual distances of the alternate landing site. If the delivered methodology of communication changed, adding specialized requirements, this would also prompt a design change to the network communication if needed. Aircraft depictions in Figure 55.0 are from [25].

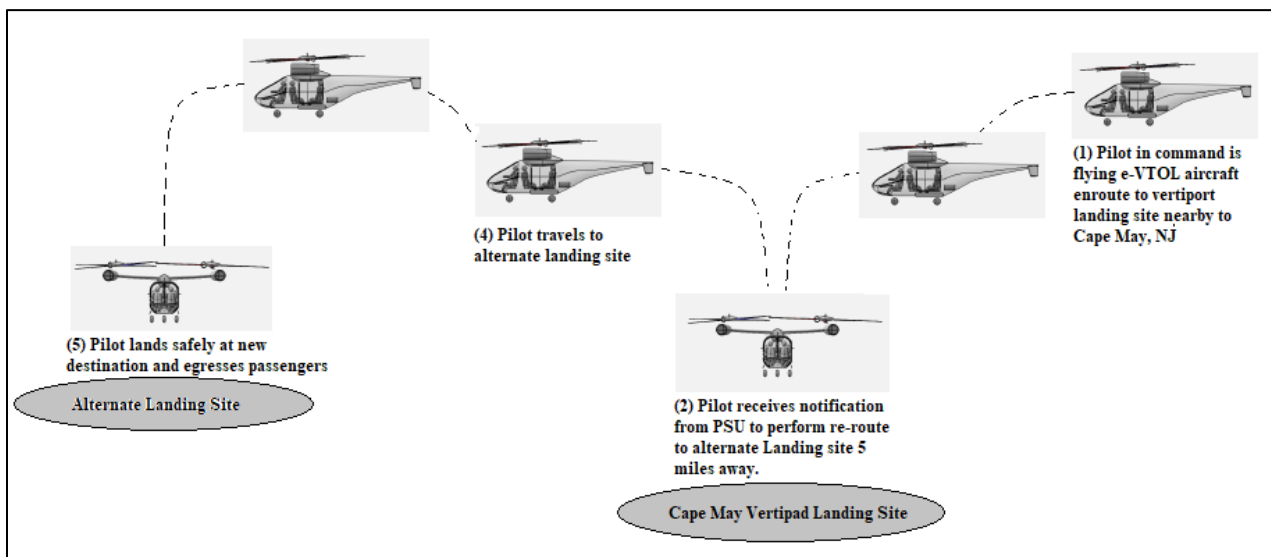

Figure 56.0: Vertiport Re-Route Off-Nominal Scenario Diagram

Activity diagrams and sequence diagrams are adequate to demonstrate off-nominal flight activities. The performed actions shown as logical sequencing is not only beneficial to explanation of the system environment but can also serve to aid in defining the roles and responsibilities of the participants in this operational environment such as the PSU, the USS, and the Pilot in Command. Mapping “actor” requirements is a crucial need in early operational concept definition when the roles of specified actors are still being determined. These informative aids provide talking points from the stakeholder level all the way through the

operator level. Figure 57.0 illustrates an activity diagram generated for a re-route off-nominal scenario. In Figure 57.0, additional detail is added to show the activities that would occur if the original mission proposed in Section 3.2 were to be re-routed to an alternate landing site. This action to perform the re-route is dependent on the instruction provided by the PSU either to perform this action or to perform a go-around.

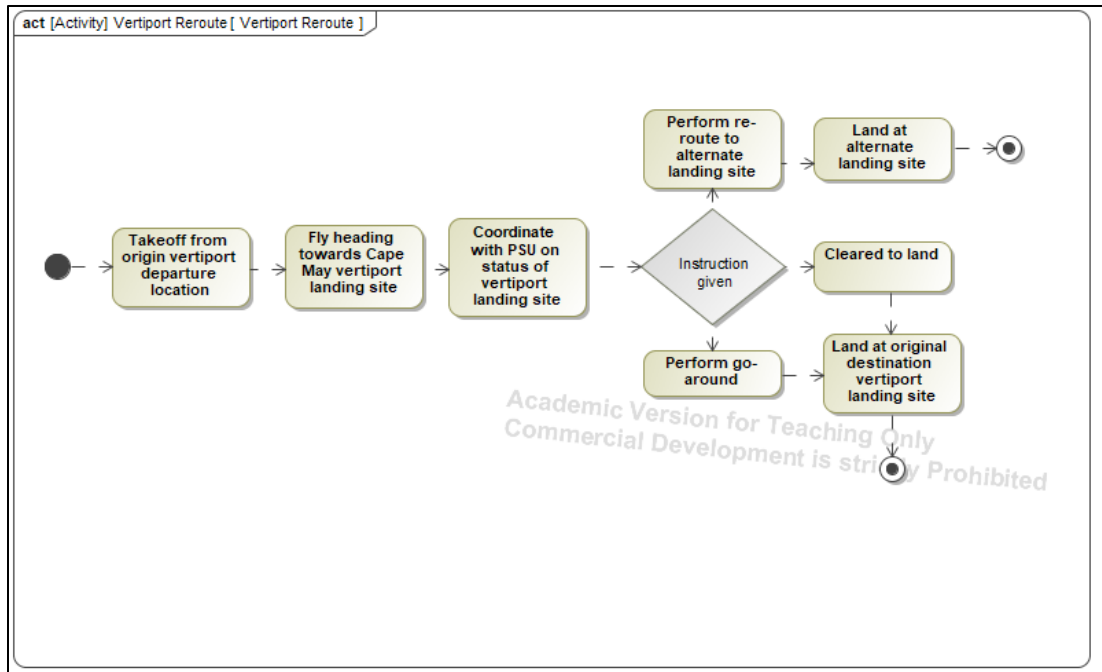

Figure 57.0: Activity Diagram for Vertiport Re-Route (Off-Nominal Scenario)

CHAPTER 5 – CONCLUSION

5.1 THESIS DELIVERABLE SUMMARY AND CONCLUSION

It has been the aim of this research to provide an intellectual discussion about the advantages of a model-based approach to UAM vehicle design and airspace architecture. There is a constructive effort to quantify the logical steps that can provide explanation of best practices by establishing a SysML model that can be used for aircraft/airspace conceptual development. Chapter 1 defined the two research questions, which this paper intended to address. The first research question was to discern if an MBSE approach to the design of an e-VTOL architecture and airspace could demonstrate the traceability of stakeholder requirements and track requirement changes to mature the modeled design intent. While this is more of an abstract concept to address, chapter three utilizes the framework of systems engineering fundamentals that has already been established going into preparing the model as mentioned in chapter two, to demonstrate this traceability. It was also crucial in chapter 3 to model the traceability of not just the vehicle itself to the stakeholder needs, but additionally the airspace infrastructure to gain an understanding of the environment which the system actors perform in. This study modeled characteristics of a selected airspace environment (Atlantic City regional area), but with a specialized focus on why this area was chosen in relation to current stakeholder needs. Additional topics concerning satisfying operational requirements and the process for establishing derived requirements are discussed in chapter four. To address the second research question, whether a fully e-VTOL design was feasible through an MBSE approach, chapter four delves into an MBSE approach to the feasibility of a fully electric design, by utilizing a series of calculations for an electric design and MBSE modeling. It was computed in this chapter that

current capacity budgets for battery specific energy could not support any long-range e-VTOL mission. A trade study of different aircraft configurations was included as part of chapter four to illustrate an approach to a design selection, given that a fully e-VTOL design was proven not feasible in the previous section.

Additional studies in the context of future work would be beneficial as more technical information becomes available with the subcomponents needed to make UAM aircraft. Additionally, to modeling off-nominal flight behavior as mentioned in chapter four, modeling airspace strategic deconfliction and tactical separation standards within the UAM corridors would also be relevant inclusion to a study such as this. In a proposed urban airspace environment predicting an urban maturity levels in the range from 10-50 to hundreds of other VTOL aircraft in that airspace volume [2], this becomes increasingly important. Additionally, an incorporation of an aviation safety management modeling system would be a potential update to the current model.

With respect to contingency management, it was alluded to earlier that mission failure events could ultimately drive a change in your Level 1 requirements. The strongest example of this is a total engine failure in a multirotor design. In this design, there is no option to “glide” the aircraft down in case of an emergency. Instead, the vehicle must be brought down by a process called “autorotation”. In this process for helicopter operations, the pilot needs to cut power to the engine to alternate to a state of flight in which the main rotor system of a helicopter or other rotary-wing aircraft turns by the action of air moving up through the rotor, rather than engine power driving the rotor. [51] Time becomes a critical factor as this also drastically shortens the projected landing/impact time.

In a case of total mission failure due to this type of scenario, the Level 1 requirements at this point would have to be updated to include safety requirements, which would necessitate a mandated redundancy in the lift and propulsion systems similar to those required for Extended Operations (ETOPS) Certification. The International Civil Aviation Organization (ICAO) issues Standards and Recommended Practices (SARPS) for ETOPS. [52] An additional update to the SysML model for future work would be to include the FAA Federal Aviation Regulations [53] when they become available for UAM aircraft and adopt any events for the FAA certification processes as part of the level 1/2 requirements in the model. As mentioned in chapter four, requirement traceability down to the subcomponent level makes it easier for the designer to knowledge capture. This feature becomes especially important when the aircraft operator is not the same as the aircraft manufacturer. The level of importance for level 1 requirements can become lost if the communicated design intent is being transmitted between several authorities. An MBSE stylized approach can provide the means of preventing this happening as it is evident that this analysis style is already being used for UAM modeling, and hopefully this document can provide a basis of how to start this process.

6.0 WORKS CITED

- [1] NASA. 2016. Systems Engineering Handbook, Revision 2. Washington, DC, USA: National Aeronautics and Space Administration (NASA). NASA/SP-2016-6105.
- [2] FAA. Office of NextGen. June 26, 2020. UAM Concept of Operations. V1.0 Foundation Principles / Roles and Responsibilities / Scenarios and Operational Threads. 800 Independence Avenue, S.W., Washington D.C. 20591
- [3] Thippavong, A. and Apaza, R. and Barmore, B. and Battiste, V. and Burian, B. and Dao, Q. and Feary, M. and Go, S. and Goodrich, K. and Homola, J. and Idris, H. and Kopardekar, P. and Lachter, J. and Neogi, N. and Ng, H. and Oseguera-Loehr, R. and Patterson, M. and Verma, S. “Urban Air Mobility Airspace Integration Concepts and Considerations” AIAA Forum, June 25-29 2018, Atlanta, Georgia.
- [4] Karina Wright “Urban Air Mobility Adds a New Dimension to Travel” July 2018. MITRE. URL: www.mitre.org/publications/project-stories/urban-air-mobility-adds-a-new-dimension-to-travel
- [5] NASA. “Advanced Air Mobility National Campaign Overview” NASA website. March 12, 2020 URL: www.nasa.gov/aeroresearch/aam/description/
- [6] Boyne, W. “Helicopter” Britannica.com URL: www.britannica.com/technology/helicopter
- [7] “Curtiss-Wright VZ-7 1958” aviastar.org. URL: aviastar.org/helicopters_eng/curtiss_vz-7.php
- [8] Bliss, L. “The Urban Helicopter Dream Is Rising Again” Bloomberg.com article. October 8, 2019 URL: www.bloomberg.com/news/articles/2019-10-08/what-s-wrong-with-urban-helicopter-commuting
- [9] “Voom-An on-demand helicopter booking platform” airbus.com. URL: www.airbus.com/innovation/zero-emission/urban-air-mobility/voom.html
- [10] “Comparative Analysis of the Main EVTOL Aircraft in Current Development” AerospaceExport Team. November 1, 2018. URL: aerospaceexport.com/comparative-analysis-of-the-main-evtol-aircrafts-in-current-development/

- [11] Tom Farrier. “When flying, is taking off really more dangerous than landing?” October 25, 2017. URL: <https://www.forbes.com/sites/quora/2017/10/25/when-flying-is-taking-off-really-more-dangerous-than-landing/?sh=7c75a76f266e>
- [12] Blain, L. “State of the game: The key players in the emerging eVTOL air taxi market” News Atlas. May 23, 2020 URL: newatlas.com/aircraft/evtol-air-taxi-flying-car-market-players/
- [13] Bacchini, A. and Cestino, E. “Electric VTOL Configurations Comparison” MDPI Aerospace article. Department of Mechanical and Aerospace Engineering, Politecnico di Torino, 10129 Turin, Italy. February 28, 2019.
- [14] “PAV – Passenger Air Vehicle-Redefining the future of safe on-demand air travel and transportation.” Aurora Flight Sciences website. URL: <https://www.aurora.aero/pav-evtol-passenger-air-vehicle/>
- [15] Polaczyk, N. and Trombino, E. and Wei, P. and Mitici, M. “A Review of Current Technology and Research in Urban On-Demand Air Mobility Applications” Vertical Flight Society Autonomous VTOL Technical Meeting and Electric VTOL Symposium, Mesa, AZ. January 29-31, 2019.
- [16] Sripad, S. and Bower, G. “Performance Metrics Required of Next Generation Batteries to Electrify Vertical Takeoff and Landing (VTOL) Aircraft”. Article in ACS Energy Letters. ACS Energy Lett. 2018, 3, 2989–2994. November 2018
- [17] Rodrigue, J. “*Energy Content of some Combustibles (in MJ/kg)*” The Geography of Transport Systems 2020. Routledge New York. ISBN 978-0-367-36463-2
- [18] Brown, A. and Harris, W. “A Vehicle Design and Optimization Model for On-Demand Aviation” AIAA SciTech Forum. Kissimmee, FL. January 8-12, 2018.
- [19] Cokoriloa, O. “Urban Air Mobility Safety Challenges” AIIT 2nd International congress on Transport Infrastructure and Systems in a changing world. Rome, Italy. September 23-24, 2019.
- [20] Head, E. “Safety is about more than aircraft design” EVTOL. June 3, 2019 URL: evtol.com/opinions/safety-is-about-more-than-aircraft-design/

- [21] Graydon, M. and Neogi, N. and Wasson, K. “Guidance for Designing Safety into Urban Air Mobility: Hazard Analysis Techniques” DOI: 10.2514/6.2020-2099. AIAA Scitech 2020 Forum. January 2020.
- [22] FAA. “Part 23 – Small Airplane Certification Process Study”. FAA Website. July 2009 URL: https://www.faa.gov/about/office_org/headquarters_offices/avs/offices/air/directorates_field/small_airplanes/media/CPS_Part_23.pdf
- [23] FAA. Number: FAA 337 “MAJOR REPAIR & ALTERATION (Airframe, Powerplant, Propeller, or Appliance)” FAA Website. October 01, 2006. URL: <https://www.faa.gov/forms/index.cfm/go/document.information/documentID/185675>
- [24] Johnson, W. “NDARC-NASA Design and Analysis of Rotorcraft Theoretical Basis and Architecture” American Helicopter Society Aeromechanics Specialists Conference, San Francisco, CA, January 20-22, 2010.
- [25] Silva, C. and Johnson, W. and Antcliff, K. and Patterson, D. “VTOL Urban Air Mobility Concept Vehicles for Technology Development” AIAA 2018-3847. Session: UAM Research Infrastructure or Operations. June 24, 2018
- [26] Silva, C and Johnson, W. and Solis, E. “Concept Vehicles for VTOL Air Taxi Operations” AHS Technical Conference on Aeromechanics Design for Transformative Vertical Flight, San Francisco, CA. January 16-19, 2018.
- [27] Vegh, M. and Botero, E. and Clark, M. and Smart, J. and Alonso. “Current Capabilities and Challenges of NDARC and SAUVE for eVTOL Aircraft Design and Analysis” AIAA Propulsion and Energy 2019 Forum. August 19-22 2019. Indianapolis, IN.
- [28] Friedenthal, S. and Oster, C. *Architecting Spacecraft with SysML – A Model-Based Systems Engineering Approach*. CreateSpace Independent Publishing Platform. 2017
- [29] Duffy, M. and Kadhiresan, A. “Conceptual Design and Mission Analysis for eVTOL Urban Air Mobility Flight Vehicle Configurations” AIAA 2019-2873. AIAA Aviation 2019 Forum. Dallas, TX. June 17-21, 2019.

- [30] Shamiyeh, M. and Rothfeld, R. and Hornung, M. and Luftfahrt, B and Germany, T. “A Performance Benchmark of Recent Personal Air Vehicle Concepts for Urban Air Mobility” 31st Congress of the International Council of the Aeronautical Sciences. Belo Horizonte, Brazil. September 9-14, 2018.
- [31] Patterson, M. and Antcliff, K. and Kohlman, L. “Proposed Approach to Studying Urban Air Mobility Missions Including an Initial Exploration of Mission Requirements” AHS International 74th Annual Forum & Technology Display, Phoenix, Arizona, May 14, 2018.
- [32] NASA Procedural Requirement 7123.1C, Systems Engineering Processes and Requirements. Effective date: February 14, 2020. URL:
<https://nodis3.gsfc.nasa.gov/displayDir.cfm?t=NPR&c=7123&s=1C>
- [33] NASA Procedural Requirement 7120.5E, NASA Space Flight Program and Project Management Requirements. Effective date: August 14, 2012. URL:
<https://nodis3.gsfc.nasa.gov/displayDir.cfm?t=NPR&c=7120&s=5E>
- [34] Hart, L. “Introduction to Model-Based Systems Engineering (MBSE) and SysML” Lockheed Martin Technical PowerPoint Presentation. Presented at the Delaware Valley INCOSE Chapter Meeting. July 30, 2015.
- [35] Ramos, A. and Ferreira, J. and Barcelo, J. “Model-Based Systems Engineering: An Emerging Approach for Modern Systems” IEEE Transactions on Systems, Man., and Cybernetics-Part C: Applications and Reviews , Vol. 42, No. 1, January 2012
- [36] Kasser, J. “Model-Based Systems Engineering: Back to the Future?” Asia-Pacific Council on Systems Engineering (APCOSE) Conference, Yokohma, 2013.
- [37] Estefan, J. “Survey of Candidate Model-Based Engineering (MBSE) Methodologies” INCOSE MBSE Initiative. May 23, 2008
- [38] Roques, P. “Modeling Requirements with SysML” Requirements Engineering Magazine. April 30, 2015 URL: re-magazine.ireb.org/articles/modeling-requirements-with-SysML
- [39] Jackson, S. “Systems Engineering for Commercial Aircraft” Aldershot. Avebury Aviation. 1977

- [40] Howard, C. “Uber defines Uber Elevate mission, vehicle requirements” May 10, 2018. URL: <https://www.intelligent-aerospace.com/commercial/article/16545303/uber-defines-uber-elevate-mission-vehicle-requirements>
- [41] Kaslow, D. and Anderson, L. and Asundi, S. and Ayres, B. and Iwata, C. and Shiotani, B. and Thompson, R. “Developing a CubeSat Model-Based Systems Engineering (MBSE) Reference Model – Interim Status” 978-1-4799-5380-6/15. IEEE Conference. 2015.
- [42] Iqbal, M. and Sartaj, H. and Khan, M. and Haq, F. “A Model-Based Testing Approach for Cockpit Display Systems of Avionics” Conference: 2019 ACM/IEEE 22nd International Conference on Model Driven Engineering Languages and Systems (MODELS) September 2019
- [43] Taarabt, S and Chen, Y. and Dore, A. and Jumpertz, R. and Bernier, A. and Compere, H. and Fransolet, M. and Macchiaiola, L. “Graduate Team Aircraft Design Competition: Electric Vertical Takeoff and Landing (E-VTOL) Aircraft Mistral Air Taxi” Liege Universite’. AIAA Graduate Team Aircraft Design Competition 2018-2019.
- [44] “Hybrid Electric Propulsion - How it works” Safran group website. URL: www.safran-group.com/hybrid-electric-propulsion-how-it-works
- [45] Ackert, S. “Aircraft Payload-Range Analysis for Financiers” Aircraft Monitor. 2013. URL: www.aircraftmonitor.com/uploads/1/5/9/9/15993320/aircraft_payload_range_analysis_for_financiers__v2
- [46] Ferrier, L. “Math on the Musk Electric Jet”. August 4, 2015. URL: <https://lochief.wordpress.com/2015/08/04/how-the-musk-electric-jet-works/?fbclid=IwAR0hhyefdZc0D1RDnLKZk2CRPo8ir4fiVtd3EBExR60OL6mLeakBWzhUQOY>
- [47] Fredericks, W. and Moore, M. and Busan, R. “Benefits of Hybrid-Electric Propulsion to Achieve 4x Cruise Efficiency for a VTOL UAV”. 2013 International Powered Lift Conference. Los Angeles, CA. August 8, 2013.
- [48] PT6 Derivatives. URL: <https://engineering.purdue.edu/~propulsi/propulsion/jets/tprops/pt6.html>

- [49] Beale, D. and Bonometti, J. “Chapter 4: System Engineering Tools” URL:
www.eng.auburn.edu/~dbeale/ESMDCourse/Chapter4.htm#SimplifiedTradeStudySteps
- [50] Adams, C. “What is a Pugh Matrix?” Modern Analyst .com URL:
www.modernanalyst.com/Careers/InterviewQuestions/tabid/128/ID/2159/What-is-a-Pugh-Matrix.aspx
- [51] “Autorotation” Wikipedia entry October 6, 2020 URL:
en.wikipedia.org/wiki/Autorotation#:~:text=Autorotation%20is%20a%20state%20of,engine%20power%20driving%20the%20rotor.
- [52] “ETOPS” Wikipedia entry October 23, 2020 URL: en.wikipedia.org/wiki/ETOPS
- [53] Federal Aviation Administration. FAA Regulations. February 19, 2020 URL:
www.faa.gov/regulations_policies/faa_regulations/
- [54] “Systems Engineering for Intelligent Transportation Systems” United States Department of Transportation - Federal Highway Administration. URL:
<https://ops.fhwa.dot.gov/publications/seitsguide/section3.htm>

APPENDIX A: THE “V” SYSTEMS ENGINEERING MODEL

The “V” systems engineering model, depicted in Figure A1.0, is often used to detail the steps taken in an SE approach. The “V” model has been in use since the 1980s and been expanded in recent years for various areas of industry. [54] As seen in the model, the conceptual exploration is followed by requirements definition for the systems. Typically, the logical architecture for the system is a precursor to physical architecture development and will be defined at a high level early. MBSE modeling can be implemented as early as conceptual development. High-level conceptual design leads to even more detailed schematics for each system. The right side of the “V” model details the verification of the subsystems and the whole system to lead into overall system validation.

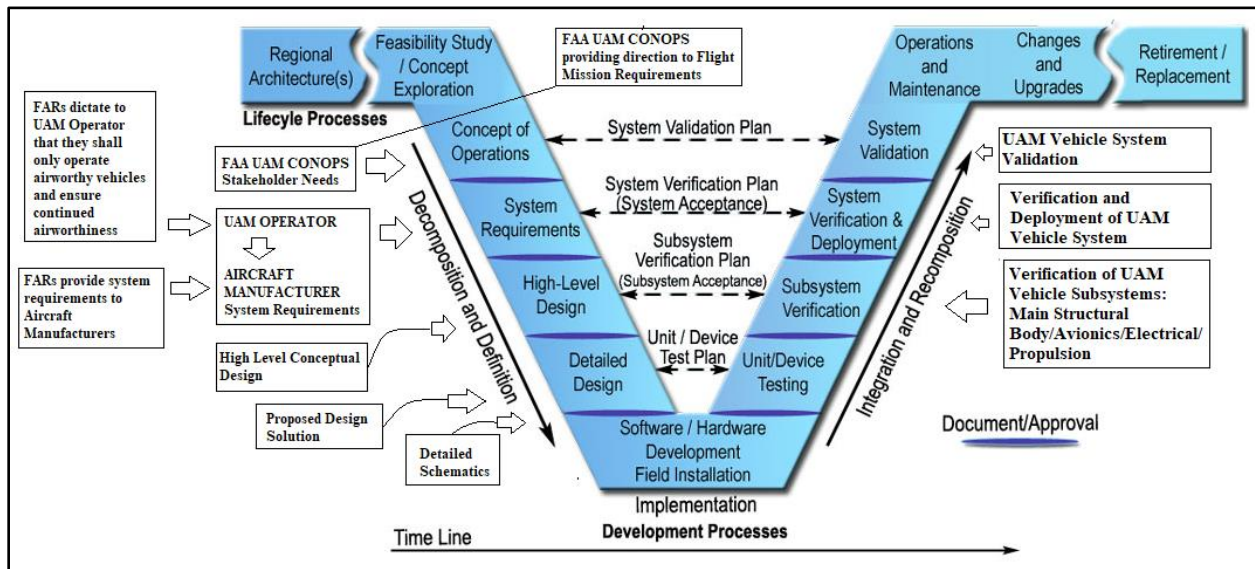

Figure A1.0: Traditional SE “V” Diagram in Relation to a MBSE UAM Vehicle Project

[52]

VITA

Heidi Glaudel began working with NASA Langley Research Center May 2012. Her primary focus when she started was working to improve the check standard testing process for various wind tunnels. Heidi originally grew up in Woodbury NJ (south NJ). She volunteered her time with Civil Air Patrol for over 7 years while attending high school and into college as well. She attended Embry-Riddle Aeronautical University in Daytona Beach FL where she received a Bachelor of Science in Aerospace Engineering (concentration in Astronautical Engineering) as of May 2007. While attending ERAU, she attended Space Academy down at Cape Canaveral/Kennedy Space Center. In her military reserve career, she was accepted as a Direct Commission Officer in the Civil Engineering Corps, September 2010. Heidi is currently as an Air Force Logistics Reserve Officer. In her civilian career, Heidi has been a practicing aerospace/mechanical engineer since 2007. In her previous positions at NASA Langley Research Center, she acted as a Data Quality Engineer and as a Test Engineer for conducting wind tunnel tests of scale models at the 14 x 22 Subsonic Wind Tunnel and a Test Director for 8-Foot-High Temperature Tunnel. Other professional affiliations include A.I.A.A, National Space Society, Smithsonian Air and Space Society, and the Reserve Officers Association. Her previous engineering experiences include manufacturing/assembly engineering for the Solid Rocket Booster component of the Space Shuttle Program (Cape Canaveral), mission assurance engineering for aerospace ordnance and ammunition programs, and design engineering for aerospace manufacturing. As of May 2020, she has been working for the National Aeronautics and Space Administration, at Langley Research Center, as a Research Aerospace Engineer.