

Received: 15 June 2019 | Revised: 8 October 2019 | Accepted: 17 November 2019

DOI: 10.1111/jfpp.14338

SPECIAL ISSUEJournal of
Food Processing and PreservationInstitute of
Food Science
& Technology **ifst****WILEY**

Real-time data collection to improve energy efficiency: A case study of food manufacturer

Sandeep Jagtap^{1,2}  | Shahin Rahimifard¹ | Linh N. K. Duong² 

¹Centre for Sustainable Manufacturing and Recycling Technologies (SMART), Loughborough University, Loughborough, UK

²National Centre for Food Manufacturing, University of Lincoln, Loughborough, UK

Correspondence

Linh N. K. Duong, National Centre for Food Manufacturing, University of Lincoln, Loughborough, UK.
Email: lduong@lincoln.ac.uk

Funding information

Engineering and Physical Sciences Research Council, Grant/Award Number: Reference: EP/K030957/1

Abstract

The rising price and demand for energy are significant issues for the food sector, which consumes a substantial amount of energy throughout the supply chain. Hence, improving energy efficiency has become an essential priority for the food sector. However, most food businesses have limited awareness of the recent technological advancements in real-time energy monitoring. Thus, the concept of “Internet of Things” (IoT) has been investigated to increase the visibility, transparency, and awareness of various energy usage levels. This paper presents a case study of a beverage factory where the implementation of an IoT-enabled sensing technology based on the embodied product energy (EPE) model helped to reduce the energy consumption. This arrangement made provision for the collection of real-time energy data within a food production system to support informed and energy-aware operational decisions, which lead to optimized energy consumption and significant savings of approximately 163,000 kWh in the year 2017.

Practical applications

Given the importance of energy efficiency and Internet of Things (IoT), especially in the food manufacturing industry, this research reports a baseline application at a beverage company in India. The results allowed the company to use energy more efficiently to have an advantage over its competitors and better market positioning. More data could be incorporated into the energy management system with the use of IoT. The availability and accuracy of such valuable data would help managers to make better energy-efficient decisions.

1 | INTRODUCTION

Energy is one of the vital resources in the food manufacturing industry. The availability of uninterrupted energy supply in the future is a reason for concern due to the depleting fossil fuel resources and increasing global population. As per the 2012 UNESCO report, the food production and supply chain were responsible for 30%

of the total global energy consumption (UN Water, 2015) and this was mainly in four-food production-related activities: Agriculture, transportation, processing, and food handling as shown in Figure 1. The threat of energy shortages and higher energy costs are already looming over the food sector and they need to address it on an urgent basis.

The food manufacturing industry is exploring in various ways to improve its energy efficiency to reduce energy costs, carbon

This is an open access article under the terms of the Creative Commons Attribution License, which permits use, distribution and reproduction in any medium, provided the original work is properly cited.

© 2019 The Authors. *Journal of Food Processing and Preservation* published by Wiley Periodicals, Inc.

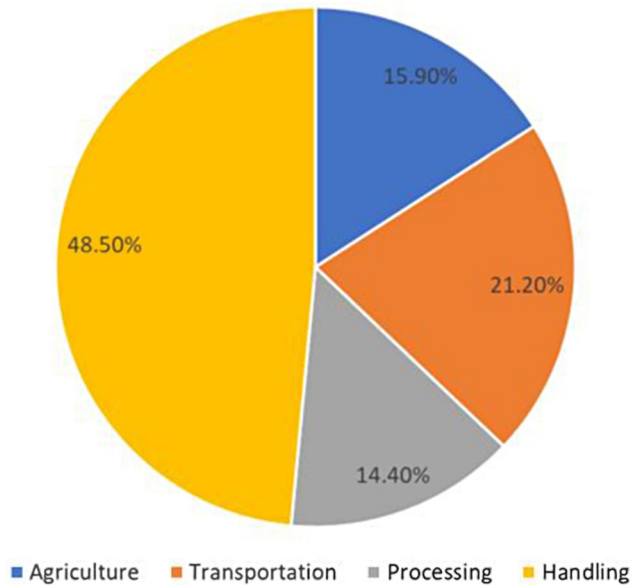

FIGURE 1 Energy in food production (Adapted from Lillie [2015])

emissions, and negative environmental impacts. Some of the options to reduce energy consumption are the reduction in the energy-intensive activities without affecting the profitability of the manufacturer or better energy management and energy recovery (Woolley, Luo, & Simeone, 2018). Energy management systems (EMS) are being widely implemented (Schulze, Nehler, Ottosson, & Thollander, 2016) in the food-manufacturing sector to achieve and sustain energy usage improvements. EMS is complicated with various parameters such as energy production, energy import/export, energy storage, energy conversion, energy transmission, and energy consumption. This situation could be further complicated by other uncertain parameters (i.e., interval, possibility, and probabilistic distributions) (Cai, Huang, Yang, & Tan, 2009). Hence, to improve the energy efficiency, there is a need for a system, which provides a detailed real-time energy usage breakdown of their production facilities.

The Internet of Things (IoT)-based energy smart meters can give visibility and reliability on the efficiency and productivity of energy consumption. It provides critical information to management on energy consumption levels of various production facilities, thereby allowing them to make better decisions in real-time to reduce overall energy usage. This paper aims at illustrating the application of the IoT-based smart energy system in reducing energy wastages in a beverage company.

The initial sections of this paper present a brief review of technologies currently adopted in food manufacturing plants to optimize the energy usage as well as a framework for measuring the embodied food product energy based on Seow and Rahimifard (2011). The latter sections present a case study on how a food manufacturing facility implemented a smart energy metering system linked to an IoT system based on the embodied product energy (EPE) model to reduce its annual energy consumption and thereby increase its profit margins. The industrial case study also demonstrates how such an

IoT-enabled smart meter system could support long-term decisions for the elimination of energy wastages within the factory.

2 | LITERATURE REVIEW

2.1 | Internet of things

The international standard ISO 50001 EMS published in 2011 supports organizations in achieving continual improvement of energy performance, including using energy more efficiently through implementing an EMS (Jovanovic & Filipovic, 2016). It establishes the structure and discipline to develop technical and management approaches that massively cut down the energy costs and greenhouse gas (GHG) emissions (Lee & Cheng, 2016)—and maximizes savings over time (OECD, 2015).

However, energy-efficient technologies and equipment are not currently pursued in the industry due to limited short-term economic benefits and the long payback time (Chiaroni et al., 2016). Therefore, Backlund, Thollander, Palm, and Ottosson (2012) stated that rather than investing in costly technologies to improve energy performances, it is worth to finance the inexpensive energy smart metering and monitoring supported by energy-efficient management practices. Tanaka (2011) suggested various activities that the industry can employ for better energy management. For example, companies can aim at sustaining, restoring, and reorganizing the equipment to minimize energy loss or retrofitting, substituting, and disposing of out-dated equipment, processing lines with novel technologies and better insulation to reduce heat loss and waste energy. Companies can also reutilize wasted heat and energy; improve management process for energy, materials, and process productivity; or restructure processes by adopting new production concepts. We invite readers to visit the recent comprehensive reviews of using cutting-edge information and communication technologies for improving energy efficiency in the manufacturing industry (e.g., Baysan, Kabadurmus, Cevikcan, Satoglu, & Durmusoglu, 2019; Choi, Thangamani, & Kissock, 2019; Kang et al., 2016).

In order to make any EMS works, the industry needs to measure its energy consumptions as accurate and detail as possible (Allen-Bradley - Rockwell Automation, 2017). However, most of the food manufacturers monitor their energy consumption through monthly energy bills (Carbon Trust, 2012). Thus, having data on energy consumption at each department and machine level is a far-fetched story (Shrouf & Miragliotta, 2015). Therefore, reducing energy consumption becomes a complicated process for decision makers in this industry. This issue can be successfully addressed by having access to real-time data on energy consumption (Shrouf et al., 2014). It is a valuable tool, which allows the decision makers to extract meaningful and actionable information for successful energy management (Efficiency New Brunswick, 2010). Recently, Meng et al. (2016) proposed a new generation by proposed integration of Microgrid Supervisory Controllers (MGSC) and EMS to optimize the operation of the system. Firouzmakan,

Hooshmand, Bornapour, and Khodabakhshian (2019) proposed a comprehensive EMS that considers uncertainties in demand, energy sources, and market price to minimize the operations costs of the distributed generation system.

Nowadays, a novel concept of the IoT, which enables physical objects to communicate and exchange data with each other using low-cost sensors, software, and other electronics has taken center stage (Li, Xu, & Zhao, 2015). IoT technology is revolutionizing the way organizations are collecting and analysing the data in order to address the operational inefficiencies in real-time (Vera-Baquero, Colomo-Palacios, & Molloy, 2016). It has already created better connectivity through visible and transparent data, business collaborations, operational changes as well as providing new services and applications (Li et al., 2015).

The food supply chains include various processes from food production to distribution, from retailers to consumers, and finally the disposal. Researchers have studied the use of emerging IoT technologies to ensure food quality, food safety, and achieve the optimal economic benefits in food supply chains. Accorsi, Bortolini, Baruffaldi, Pilati, and Ferrari (2017) proposed a general method to manage the application of IoT in food supply chains. The method enables companies to improve operational performance by having better insights into the processes and the relationships between actors. Similarly, Pang, Chen, Han, and Zheng (2015) used sensor portfolios and information fusion to create a value-centric business-technology framework. Subramaniaswamy et al. (2019) developed an IoT-based support system on the food recommendation-based health management. By employing the IoT platform, the authors proved that the system helps reducing energy consumption.

In general, IoT is being considered as a way to improve operational performance, safety, and profits by monitoring the quality, tracking food logistics, predictive maintenance, and warehouse management to avoid spoilage of food (Pang et al., 2015). IoT is swiftly spreading its wing across various operations within food manufacturing, and energy is one of the many interesting domains where it can have

a significant impact and influence. IoT provides a real-time solution for monitoring energy consumption to decision makers with the key data of machines, the production lines, and even at the factory level (Shrouf & Miragliotta, 2015). To advocate the use of IoT, especially for energy efficiency, Arshad, Zahoor, Shah, Wahid, and Yu (2017) summarized major challenges in the IoT applications and proposed different solutions for these challenges. The results highlight the needs for further research on IoT in energy efficiency.

2.2 | Embodied food product energy framework

Most of the food manufacturers are aware of their energy usage through their monthly or quarterly energy bills. However, they are not aware of the detailed energy usage at the machine or departmental level. It is, therefore, necessary for food manufacturers to understand the energy patterns and key data on energy usage at the process level in order to reduce their overall energy consumption. In this context, the food manufacturers should have access to a smart system that can measure the energy used by various manufacturing processes for a given food product. Seow and Rahimifard (2011) defined a framework for modeling EPE, as shown in Figure 2. In this framework, the EPE consists of two energy groups, including, direct energy (DE) and indirect energy (IE).

The DE is the energy used by various processes to manufacture a food product (e.g., washing, cooking, packing, or inspection), whereas the IE is the energy utilized by activities to sustain the environment in which the production processes are carried out within a food factory (e.g., lighting, heating, and utilities). The DE can be further classified as theoretical energy (TE) and auxiliary energy (AE). TE is defined as the minimum energy needed to carry out a certain process (e.g., energy for washing vegetables), whereas AE is the energy required for supporting nonproductive activities (e.g., machine start-up or on standby). The total of DE (i.e., TE + AE) and IE for all the activities within a food production system represent the total

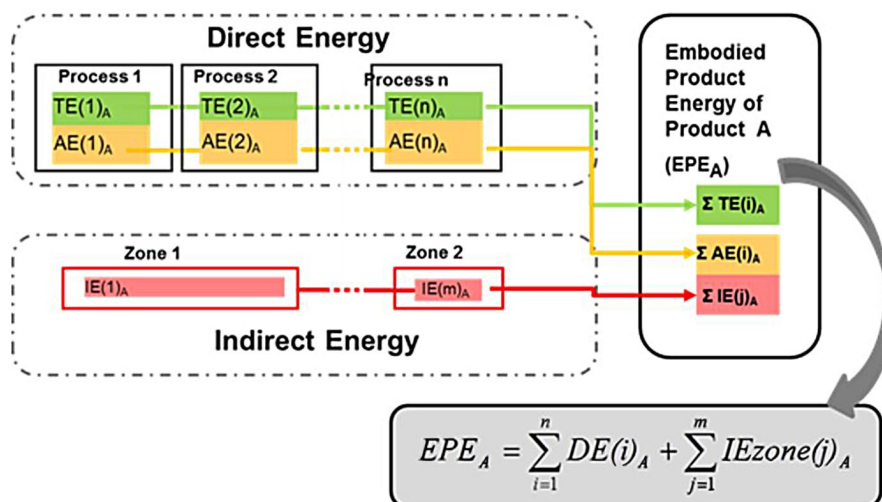

FIGURE 2 Embodied product energy framework (Adapted from Seow and Rahimifard (2011))

embodied energy of the food product. The smart energy monitoring system, therefore, should be able to identify all kinds of energy mentioned above in order to be energy efficient.

Adopting such smart energy monitoring and modeling in food production systems would result in detail information on the energy usage by various processes and could identify energy hotspots within a factory. Those processes, which are energy-intensive, can be substituted with less energy-intensive processes to improve energy efficiency. Besides, such breakdown of energy usage data at process level can be used to investigate the effect of other production parameters such as the number of trial runs, batch size, production schedules, and can provide detail understanding of which production parameters combination yield best energy efficiency results without affecting production outputs.

2.3 | IoT architectural layers

In order to be energy-aware through the EPE model, food manufacturers can adopt an IoT-based approach of installing smart energy meters at various energy hotspots coupled with software to support the task team (decision makers) to monitor the energy consumption patterns and trends. It will, in turn, help decision makers to devise solutions to reduce the overall energy consumption and this could be achieved by adopting a simple four-layered architecture based on Jagtap and Rahimifard (2017) and Li et al. (2015), which is described as follows:

- Sensing layer—The bottom layer consists of smart energy meters, which captures the energy consumption data that are required by decision makers for monitoring and benchmarking energy patterns. In order to track both DE and IE, which is based on the EPE model, the smart meters are installed at various energy hotspots within food manufacturing as identified by the stakeholders.
- Networking Layer—The communication between various things such as smart energy meters, users or employees, and servers are carried out via a wireless network. This layer provides a seamless transfer of data between smart meters and host server via wireless communications (Internet, Bluetooth) or wired communication. In this layer, both the DE and IE data collected by the smart meters based on the EPE model are transferred to the Service layer for further processing to extract meaningful and actionable energy information.
- Service Layer—The real-time energy data, that is, both DE and IE data based on the EPE model are acquired from the smart energy meters and are stored on the server. The stored data are continuously analyzed using a software to plot energy patterns and trends. This layer is the most important as it contains all the logic and processes the data in order to make the application work.
- Application Layer—The final and the topmost layer serves the users with detailed analysis of energy consumption in the form of dashboards, sends alerts, and generates reports. It makes use of control buttons on the user interface application to communicate

with backend software to process both the DE and IE data based on the EPE model.

3 | MATERIALS AND METHODS

3.1 | Case study

The studied company is based in India. It is one of the largest beverage manufacturing plants and operates three bottle-filling lines in a 24-hr shift. Due to the rising raw material and energy prices, which led to higher manufacturing costs, the company decided to focus on reducing the energy bills. As the company aims to be a sustainable business and in order to compete with other beverage manufacturers the company must take initiatives in reducing the manufacturing costs to increase its profitability. Since influencing the raw material cost was not within their control, the only possible solution, in order to remain sustainable, was to improve energy efficiency through the implementation of an IoT-enabled EMS based on the EPE model.

3.2 | Method

Top management was committed toward the adoption and implementation of the IoT-enabled EMS based on the EPE model. The research team wanted to encourage employees to get involved and understand the new system. An expert team was formed including a mix of senior and junior management members from various departments for having their opinions on the DE and IE performance of their respective departments.

Energy sources were identified, and the historical energy trends and patterns and the current demands were evaluated. Machines, equipment, people, processes, and the departments, which contributed to the significant amount of DE and IE usage, were recognized. In order to improve the energy efficiency of the manufacturing facility, the conditions that attributed to the excessive amount of energy consumption were prioritized and other energy-saving opportunities were pursued. The initial energy consumption analysis supported the decision makers by setting up an energy baseline and target for each department.

4 | RESULTS AND DISCUSSION

Energy smart meters in each department and on some machines were measured for their respective energy consumption. It allowed the daily real-time monitoring of DE and IE usage and efficiency of each entity based on the EPE model. Figure 3 shows how each process and power-hungry equipment such as boilers and cooling towers mounted with smart energy meters were deployed to measure their energy consumption. The DE and IE data collected by these smart meters based on the EPE model are transmitted wirelessly to a central database where they are stored and

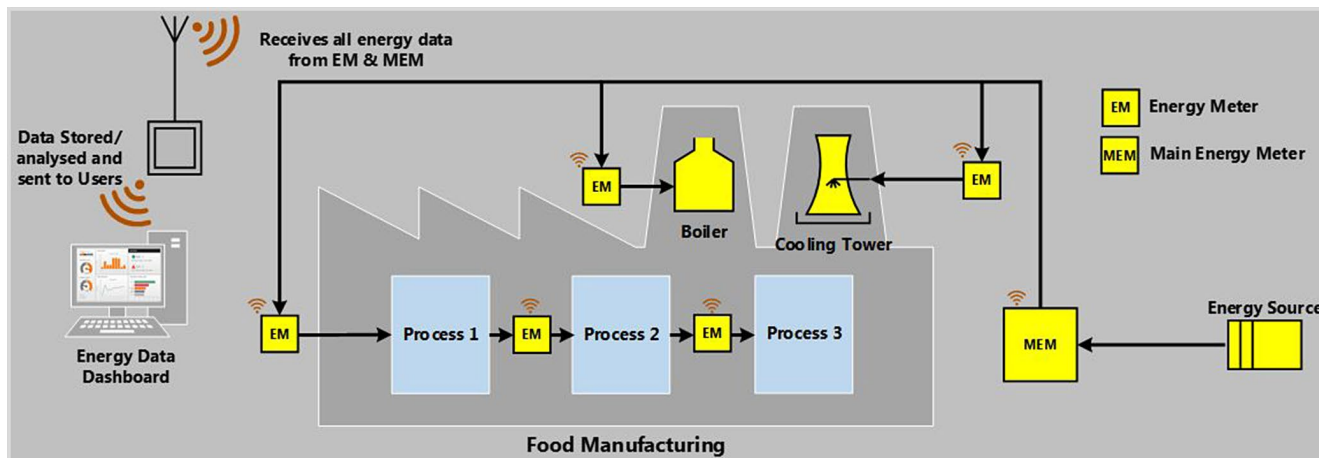

FIGURE 3 Energy monitoring system

		Electricity Consumption Data									
Month		Apr-17	May-17	Jun-17	Jul-17	Aug-17	Sep-17	Oct-17	Nov-17	Dec-17	Jan-18
Finished product in Litres	kL/month	129034	117938	114715	127886	121232	110427	124080	94089	126092	119330
Expected Electricity Consumption	kWh/month	149966	138313	134929	148760	141772	130426	144763	113268	146876	139775
Target Electricity Consumption	kWh/month	148456	136921	133570	147263	140345	129112	143306	112126	145398	138368
Actual Electricity consumption	kWh/month	189399	193937	199101	210850	120750	96510	103524	82843	110501	102777
Savings	kWh/month	-39433	-55624	-64172	-62090	21022	33916	41239	30425	36375	36998

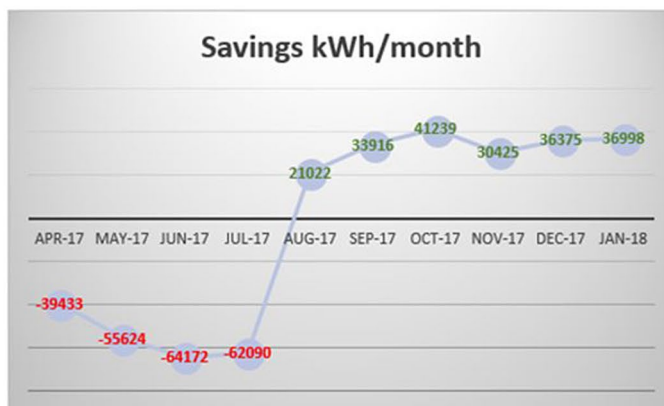

FIGURE 4 Electricity consumption data and electricity savings

analyzed to extract meaningful and actionable information. The extracted meaningful and actionable energy information is presented to all the energy-concerned employees in the form of user-friendly dashboards.

The research team collected the energy data based on the EPE model for 10 months starting from April 2017, as shown in Figure 4. The finished product row shows the number of beverages manufactured each month in kiloliters (m³). Based on the historical production data from the best performing site within the group, the average expected electricity consumption data were derived. The average expected electricity consumption data were calculated from the number of liters of finished beverages produced per kWh of electricity consumed. The target electricity consumption was decided by the expert team and was always kept below the expected electricity consumption on an average by 1,400 kWh in order to compensate for the unpredicted increase in orders or energy-consuming

refurbishments. The actual electricity consumption data are the data recorded by the newly installed smart energy meters. The savings row shows how much electricity was saved or lost for each month. For April 2017 to July 2017, the factory overused the electricity and there were no savings, which are highlighted in red. During these 4 months, the research team monitored and analyzed the energy consumption of various machines and equipment and narrowed down, which energy-saving projects to be undertaken. The team identified five energy-saving projects which were implemented by the end of July 2017 by the Pareto principle. These initiatives helped them to reduce their energy consumption and the benefits could be seen in green for August 2017 to January 2018.

The IoT-enabled energy monitoring system based on the EPE model gave the task team to access significant amounts of DE and IE data with structure. The energy task team undertook five projects after monitoring their energy consumption for the first 4 months,

TABLE 1 Energy-saving projects

Sr. no.	Energy-saving projects	Per annum savings kWh	Annual savings in USD (\$)	Initial cost in USD (\$)	Payback period (months)
1	Replacing 10 TPH boiler with six TPH boiler	–	74,374	85,825	13.85
2	To replace 36 watts white tube lights with 16 watts Light Emitting Diode (LED) tube lights	661,305	85,667	30,054	4.48
3	To install Variable Frequency Drive (VFD) in beverage filling pumps	17,184	2,090	1,431	8.22
4	Replacing fluid coupling motor with efficient VFD motor	8,592	1,044	2,175	24.65
5	Converting chiller plant to humidification plant	120,000	14,316	42,950	35.29

as shown in Table 1. The team proposed each project to senior management and presented them with a payback period for each investment. All the projects were successfully delivered due to the structured energy data on demand, following the EPE framework using the IoT-based monitoring system. The monitoring system provided greater visibility and energy performance of projects as well as increased stakeholder engagement throughout the company and reduction of carbon footprint.

5 | CONCLUSION AND FURTHER WORKS

This paper addresses how the EPE model supported with the novel concept of IoT can be utilized to monitor both DE and IE in real-time and thereby improve the energy efficiency of the food-manufacturing unit. It allowed a high level of energy awareness among the decision makers enabling them to make better decisions related to energy usage. The detailed categorization of EPE data allowed management to understand their energy consumption patterns. The theory was proved through a case study of the beverage factory, which showed how it was able to achieve \$172,281 of annual energy savings and save 807,081 kWh/annum of electricity. It further demonstrated how IoT-enabled energy monitoring solutions based on the EPE model are vital for the food sector and need to be embedded in the factory's energy management initiatives. However, during the implementation of the case study it was realized that installing energy smart-meters on factory floor was the most challenging due to the risk of stoppage in food production and product wastage and contamination. Also, the ability to understand production-related decisions that are resulting in higher consumption of energy would be a topic of further study.

ACKNOWLEDGMENTS

This work was supported by the Engineering and Physical Sciences Research Council (EPSRC) Centre for Innovative Manufacturing in Food [Reference: EP/K030957/1].

CONFLICT OF INTEREST

The authors have declared no conflict of interest for this article.

ORCID

Sandeep Jagtap  <https://orcid.org/0000-0001-5271-0192>

Linh N. K. Duong  <https://orcid.org/0000-0002-9415-1082>

REFERENCES

- Accorsi, R., Bortolini, M., Baruffaldi, G., Pilati, F., & Ferrari, E. (2017). Internet-of-things paradigm in food supply chains control and management. *Procedia Manufacturing*, 11, 889–895. <https://doi.org/10.1016/j.promfg.2017.07.192>
- Allen-Bradley - Rockwell Automation. (2017). *How a well-planned strategy can help the food & beverage industry more effectively manage its energy-related costs*. Milwaukee, WI: Rockwell Automation.
- Arshad, R., Zahoor, S., Shah, M. A., Wahid, A., & Yu, H. (2017). Green IoT: An investigation on energy saving practices for 2020 and beyond. *IEEE Access*, 5, 15667–15681. <https://doi.org/10.1109/ACCESS.2017.2686092>
- Backlund, S., Thollander, P., Palm, J., & Ottosson, M. (2012). Extending the energy efficiency gap. *Energy Policy*, 392–396. <https://doi.org/10.1016/j.enpol.2012.08.042>
- Baysan, S., Kabadurmus, O., Cevikcan, E., Satoglu, S. I., & Durmusoglu, M. B. (2019). A simulation-based methodology for the analysis of the effect of lean tools on energy efficiency: An application in power distribution industry. *Journal of Cleaner Production*, 211, 895–908. <https://doi.org/10.1016/j.jclepro.2018.11.217>
- Cai, Y., Huang, G., Yang, Z., & Tan, Q. (2009). Identification of optimal strategies for energy management systems planning under multiple uncertainties. *Applied Energy*, 86(4), 480–495. <https://doi.org/10.1016/j.apenergy.2008.09.025>
- Carbon Trust. (2012). *Food and drink processing—Introducing energy saving opportunities for business*. London, UK: Carbon Trust.
- Chiaroni, D., Chiesa, M., Chiesa, V., Franzo, S., Frattini, F., & Toletti, G. (2016). Introducing a new perspective for the economic evaluation of industrial energy efficiency technologies: An empirical analysis in Italy. *Sustainable Energy Technologies and Assessments*, 15, 1–10. <https://doi.org/10.1016/j.seta.2016.02.004>
- Choi, J. K., Thangamani, D., & Kissock, K. (2019). A systematic methodology for improving resource efficiency in small and medium-sized enterprises. *Resources, Conservation and Recycling*, 147, 19–27. <https://doi.org/10.1016/j.resconrec.2019.04.015>

- Efficiency New Brunswick. (2010). *Energy management information systems—Planning manual and tool*. Saint John, Canada: Natural Resources Canada.
- Firouzmand, P., Hooshmand, R. A., Bornapour, M., & Khodabakhshian, A. (2019). A comprehensive stochastic energy management system of micro-CHP units, renewable energy sources and storage systems in microgrids considering demand response programs. *Renewable and Sustainable Energy Reviews*, 108, 355–368. <https://doi.org/10.1016/j.rser.2019.04.001>
- Jagtap, S., & Rahimifard, S. (2017). Utilisation of Internet of Things to improve resource efficiency of food supply chains. In *8th International Conference on Information and Communication Technologies in Agriculture, Food and Environment (HAICTA 2017)* (pp. 8–19). Chania, Crete Island, Greece: CEUR-WS.org.
- Jovanovic, B., & Filipovic, J. (2016). ISO 50001 standard-based energy management maturity model—Proposal and validation in industry. *Journal of Cleaner Production*, 112, 2744–2755. <https://doi.org/10.1016/j.jclepro.2015.10.023>
- Kang, H. S., Lee, J. Y., Choi, S., Kim, H., Park, J. H., Son, J. Y., ... Do Noh, S. (2016). Smart manufacturing: Past research, present findings, and future directions. *International Journal of Precision Engineering and Manufacturing-Green Technology*, 3(1), 111–128. <https://doi.org/10.1007/s40684-016-0015-5>
- Lee, D., & Cheng, C.-C. (2016). Energy savings by energy management systems: A review. *Renewable and Sustainable Energy Reviews*, 56, 760–777. <https://doi.org/10.1016/j.rser.2015.11.067>
- Li, S., Xu, L. D., & Zhao, S. (2015). The internet of things: A survey. *Information Systems Frontiers*, 17(2), 243–259. <https://doi.org/10.1007/s10796-014-9492-7>
- Lillie, K. (2015, November 19). *Energy use in food production*. Obtido de Choose Energy. Retrieved from <https://www.chooseenergy.com/blog/energy-101/energy-food-production/>
- Meng, L., Sanseverino, E. R., Luna, A., Dragicevic, T., Vasquez, J. C., & Guerrero, J. M. (2016). Microgrid supervisory controllers and energy management systems: A literature review. *Renewable and Sustainable Energy Reviews*, 60, 1263–1273. <https://doi.org/10.1016/j.rser.2016.03.003>
- OECD. (2015). *An introduction to energy management systems: Energy savings and increased industrial productivity for the iron and steel sector*. Paris, France: Directorate for Science, technology and Innovation Steel Committee. Retrieved from [https://www.oecd.org/sti/ind/DSTI-SU-SC\(2014\)14-FINAL-ENG.pdf](https://www.oecd.org/sti/ind/DSTI-SU-SC(2014)14-FINAL-ENG.pdf)
- Pang, Z., Chen, Q., Han, W., & Zheng, L. (2015). Value-centric design of the internet-of-things solution for food supply chain: Value creation, sensor portfolio and information fusion. *Information Systems Frontiers*, 17(2), 289–319. <https://doi.org/10.1007/s10796-012-9374-9>
- Schulze, M., Nehler, H., Ottosson, M., & Thollander, P. (2016). Energy management in industry: A systematic review of previous findings and an integrative conceptual framework. *Journal of Cleaner Production*, 112, 3692–3708. <https://doi.org/10.1016/j.jclepro.2015.06.060>
- Seow, Y., & Rahimifard, S. (2011). A framework for modelling energy consumption within manufacturing systems. *CIRP Journal of Manufacturing Science and Technology*, 4(3), 258–264. <https://doi.org/10.1016/j.cirpj.2011.03.007>
- Shrouf, F., Ordieres, J., & Miragliotta, G. (2014). Smart factories in Industry 4.0: A review of the concept and of energy management approached in production based on the Internet of Things paradigm. In *2014 IEEE International Conference on Industrial Engineering and Engineering Management* (pp. 697–701). Bandar Sunway, Malaysia: IEEE.
- Shrouf, F., & Miragliotta, G. (2015). Energy management based on Internet of Things: Practices and framework for adoption in production management. *Journal of Cleaner Production*, 100, 235–246. <https://doi.org/10.1016/j.jclepro.2015.03.055>
- Subramaniaswamy, V., Manogaran, G., Logesh, R., Vijayakumar, V., Chilamkurti, N., Malathi, D., & Senthilselvan, N. (2019). An ontology-driven personalized food recommendation in IoT-based healthcare system. *The Journal of Supercomputing*, 75(6), 3184–3216. <https://doi.org/10.1007/s11227-018-2331-8>
- Tanaka, K. (2011). Review of policies and measures for energy efficiency in industry sector. *Energy Policy*, 39, 6532–6550. <https://doi.org/10.1016/j.enpol.2011.07.058>
- Vera-Baquero, A., Colomo-Palacios, R., & Molloy, O. (2016). Real-time business activity monitoring and analysis of process performance on big-data domains. *Telematics and Informatics*, 33(3), 793–807. <https://doi.org/10.1016/j.tele.2015.12.005>
- UN Water. (2015). *Water, food and energy*. Obtido de UN Water. Retrieved from <http://www.unwater.org/water-facts/water-food-and-energy/>
- Woolley, E., Luo, Y., & Simeone, A. (2018). Industrial waste heat recovery: A systematic approach. *Sustainable Energy Technologies and Assessments*, 29, 50–59. <https://doi.org/10.1016/j.seta.2018.07.001>

How to cite this article: Jagtap S, Rahimifard S, Duong LNK. Real-time data collection to improve energy efficiency: A case study of food manufacturer. *J Food Process Preserv*. 2019;00:e14338. <https://doi.org/10.1111/jfpp.14338>