



Aalborg Universitet

AALBORG UNIVERSITY  
DENMARK

## The Equivalent Relationship between Space Vector and Carrier-based PWM Modulation Strategy in Current Source five-level Inverters

Cheng, Ruiqi; He, Yingjie; Deng, Qinrui; Wang, Yue; Guo, Haoting

*Published in:*  
Journal of Physics: Conference Series

*DOI (link to publication from Publisher):*  
[10.1088/1742-6596/1449/1/012004](https://doi.org/10.1088/1742-6596/1449/1/012004)

*Creative Commons License*  
CC BY 3.0

*Publication date:*  
2020

*Document Version*  
Publisher's PDF, also known as Version of record

[Link to publication from Aalborg University](#)

*Citation for published version (APA):*  
Cheng, R., He, Y., Deng, Q., Wang, Y., & Guo, H. (2020). The Equivalent Relationship between Space Vector and Carrier-based PWM Modulation Strategy in Current Source five-level Inverters. *Journal of Physics: Conference Series*, 1449(1), [012004]. <https://doi.org/10.1088/1742-6596/1449/1/012004>

### General rights

Copyright and moral rights for the publications made accessible in the public portal are retained by the authors and/or other copyright owners and it is a condition of accessing publications that users recognise and abide by the legal requirements associated with these rights.

- ? Users may download and print one copy of any publication from the public portal for the purpose of private study or research.
- ? You may not further distribute the material or use it for any profit-making activity or commercial gain
- ? You may freely distribute the URL identifying the publication in the public portal ?

### Take down policy

If you believe that this document breaches copyright please contact us at [vbn@aub.aau.dk](mailto:vbn@aub.aau.dk) providing details, and we will remove access to the work immediately and investigate your claim.

PAPER • OPEN ACCESS

## The Equivalent Relationship between Space Vector and Carrier-based PWM Modulation Strategy in Current Source five-level Inverters

To cite this article: Ruiqi Cheng *et al* 2020 *J. Phys.: Conf. Ser.* **1449** 012004

View the [article online](#) for updates and enhancements.



**The Electrochemical Society**  
Advancing solid state & electrochemical science & technology

The ECS is seeking candidates to serve as the  
**Founding Editor-in-Chief (EIC) of ECS Sensors Plus,**  
a journal in the process of being launched in 2021

The goal of ECS Sensors Plus, as a one-stop shop journal for sensors, is to advance the fundamental science and understanding of sensors and detection technologies for efficient monitoring and control of industrial processes and the environment, and improving quality of life and human health.

*Nomination submission begins: May 18, 2021*



Nominate now!

# The Equivalent Relationship between Space Vector and Carrier-based PWM Modulation Strategy in Current Source five-level Inverters

Ruiqi Cheng<sup>1</sup>, Yingjie He<sup>1,2\*</sup>, Qinrui Deng<sup>1</sup>, Yue Wang<sup>1</sup> and Haoting Guo<sup>1</sup>

<sup>1</sup>Electrical engineering College, Xi'an Jiao Tong University, Xi'an, Shanxi, 710049, China

<sup>2</sup>Electrical engineering College, Aalborg University, Aalborg, The Kingdom of Denmark

\*hyj202411@sina.com

**Abstract.** In order to achieve equivalent modulation of the three-phase five-level current source converter, this paper, based on the topology of three-phase five-level current-source converter, proposes a new method to realize the output characteristic of SVPWM with CBPWM, and this method can be applied in any space vector modulation sector of the topology. Different from the strategies of traditional unity theory, the proposed method decomposes the modulated waves directly according to the switching states of SVPWM in five-level current source converters and compare the sub-modulation waves with two inverting carriers. Finally, a simulation on MATLAB is carried out to verify the correction of the method.

## 1. Introduction

Nowadays, multi-level converters are widely used in medium and high voltage applications.<sup>[1-3]</sup> Compared with the multi-level voltage converters, the research on multi-level current-source converters (CSC) is still in its infancy, and there are still many problems worthy of investigation. The main reason for this phenomenon is that there is a limitation on the energy storage of current-type converters. In recent years, the improvement of high-temperature superconducting technology and the performance of energy storage coils will surely become a propeller for the development of multi-level current-mode converters and the unique advantages of the CSC itself will receive more and more attention.<sup>[4-6]</sup> Therefore, the study of multilevel current-source converter topology and its modulation strategy is of great significance.

The commonly used modulation methods for current-source multilevel converters are mainly divided into two categories: space vector modulation (SVPWM) and triangular carrier-based modulation (CBPWM). Among them, CBPWM is more mainstream. This is because the current-source converter has more degrees of freedom than the voltage-source converter, which greatly increases the complexity of SVPWM modulation, and CBPWM is simpler and easier. However, compared to CBPWM, SVPWM also has many advantages, such as: higher DC side utilization, better harmonic characteristics, lower switching losses, etc.<sup>[7-9]</sup> Therefore, it is not difficult to find that CBPWM and SVPWM have complementary advantages, if the equivalent relationship between CBPWM and SVPWM can be derived. Then, the excellent characteristics of the space vector can be achieved by using a simple carrier modulation method. It can be seen that the study of the equivalent relationship is extremely valuable, especially for multi-level converters with more cumbersome control methods.



The equivalent relationship between CBPWM and SVPWM has been proposed before, but the current research on this problem is limited to the voltage converter topology. In [10], the paper derives the zero-sequence voltage vector to realize the equivalent effects of the two modulation strategies. However, this method is limited to 8-segment sequence, and the output level of each phase can only be two levels. In [11], a new modulation wave decomposition strategy is proposed, which makes it possible to decompose the space vector output sequence of more than 8 segments under the multi-level voltage converter topology, and perfect the realization of the equivalent relationship; [12] further improve the equivalent of SVPWM and CBPWM under multi-level NPC with more than 8 segments, and extend the equivalent to any number of segments under n-level.

However, by analysing the characteristics of the current-mode converter, it can be found that: 1) the same level state corresponds to a large number of switching states; 2) there is no complementary conduction relationship between the upper and lower switching tubes, and there are multiple switching actions in one cycle; 3) The state is not simply turned on first then off or off first then on in a cycle. The existing modulation wave decomposition strategy is not applicable to CSC, so there is still no reasonable way to achieve the equivalent of SVPWM and CBPWM modulation methods in CSC topology.

In order to solve this problem, based on the current-source cascaded multilevel converter topology, the structure and space vector modulation strategy are deeply analysed, and a new equivalent relationship realization method is proposed. The method adopts the idea of equivalent switching states, decomposes the modulated wave according to different situations, and finally obtains the modulation signal required by each switching tube by using dual inverting carrier modulation and realizes the equivalent of the two modulation strategies. The method effectively solves the problem that SVPWM has only redundant switching amount and no redundant level in the CSC topology, which the traditional method cannot achieve. The corresponding formula derivation and the expression of each modulation wave are given, and the correctness of the proposed method is verified by simulation.

## 2. Current-source five-level converter SVPWM modulation principle and switching sequence

### 2.1. Five-level current converter SVPWM modulation principle

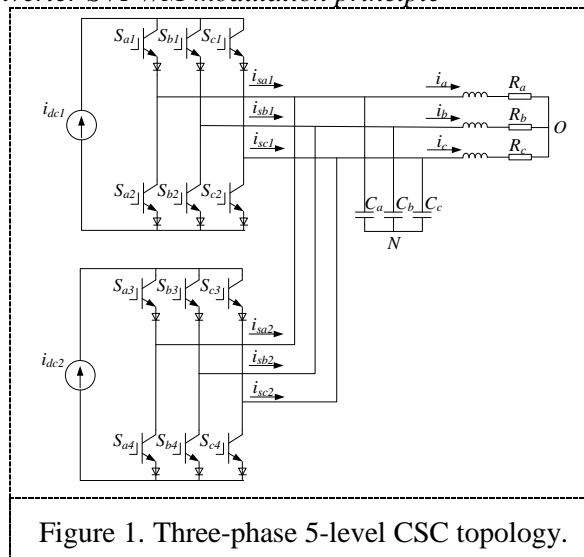

Fig. 1 shows the topology of a three-phase 5-level current-mode converter, which is cascaded by two three-phase three-level current-mode converters. For each cascading module, the output level has the same relationship as the switch state, and both outputs  $i_{dc}$ , 0, and  $-i_{dc}$ . Therefore, after the two modules are superimposed, five levels can be output.<sup>[6]</sup>

In order to ensure the continuity of the current source output current, for each individual module, the upper and lower arms of the three phases must be met at any one time and only one power switch can be turned on. The space vector diagram corresponding to the corresponding  $\alpha\beta$  coordinates can be

obtained. Fig. 2 uses the traditional level state to represent the corresponding current vector. At this time, each vector only corresponds to a single output current level state. However, in CSC, an output current switching logic may correspond to more Switching state, so the traditional expression cannot fully reflect the switch combination characteristics of CSC. To solve this problem, the switch state is directly used to represent each space vector, as shown in Fig. 3.

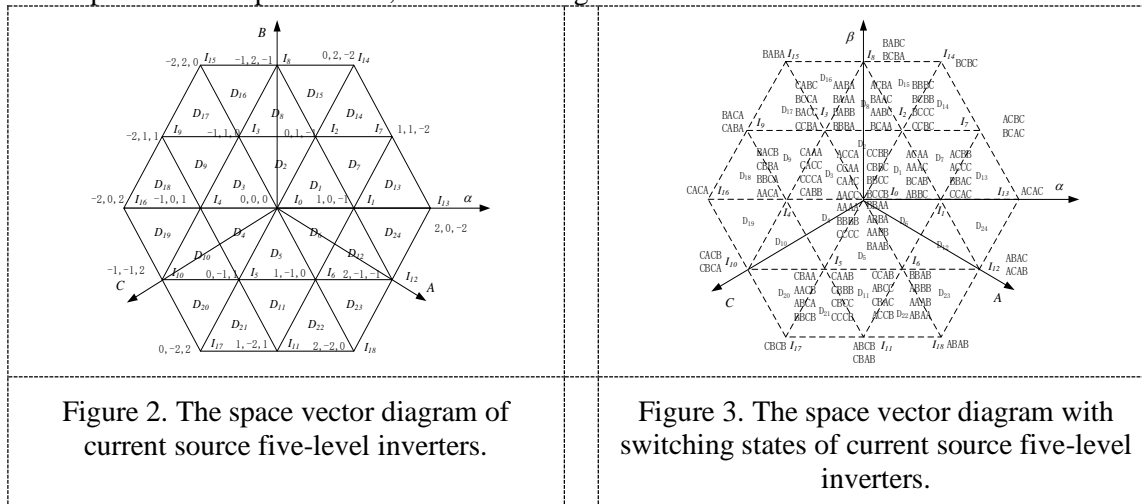

Figure 2. The space vector diagram of current source five-level inverters.

Figure 3. The space vector diagram with switching states of current source five-level inverters.

Each space vector in Fig. 3 is composed of a plurality of switch states. Taking the small vector I1 as an example, the switch states indicated by ACAA are:  $S_{a1}$ ,  $S_{c2}$ ,  $S_{a3}$ , and  $S_{a4}$  are turned on, and other switches are turned off. At this time, the A phase output current is +1 level, the B phase output current is 0 level, and the C phase output current is -1 level, corresponding to the I1 (1, 0, -1) vector in Fig. 2. The meaning of this type of other switch states is the same.

However, due to the characteristics of the current-mode converter, each switching state must have multiple switching tubes operating at the same time. To reduce switching losses and harmonics, the space vector modulation of the current-source converter must follow the two principles:

- Each switch state switch has only one row of switch action;
- Each switch has only one switch action in half of the modulation period.

Based on these two modulation principles, the SVPWM modulation sequence of the five-level current-mode converter combined by two modules can be up to 10 segments. Equivalent relationship between five-level current converter SVPWM and CBPWM.

## 2.2. Equivalent relationship between traditional voltage five-level converter SVPWM and CBPWM

The traditional equivalent relationship research is mainly for voltage-type converters and is limited to two-level or three-level 8-segment modulation. When the number of levels and the number of modulation segments increase, the number of intersections between the modulated wave and the carrier can be increased. Therefore, it is possible to output more currents, and it is often necessary to decompose the modulated waves of the CBPWM regularly. Among them, the paper [11] proposed a method of modulating wave decomposition. Based on the principle of area equivalence, a certain number of sub-modulation waves are obtained according to the state of each vector action time and output level.

Figure 4 shows a three-level, 14-segment SVPWM full-switch sequence. The vector action time and level state of each SVPWM are shown in the upper part of Fig. 4. Through the correspondence between the level state and the modulated carrier, the corresponding sub-modulated wave waveforms in the modulation period can be obtained, and each phase modulated wave is decomposed into two sub-modulations. The wave is shown in the lower half of Figure 4. Among them,  $V_a^*$ ,  $V_b^*$ ,  $V_c^*$  are modulated waves, VT1 and VT2 are triangular carriers, and A, B, and C waveforms represent the output level states of each phase in one modulation period.

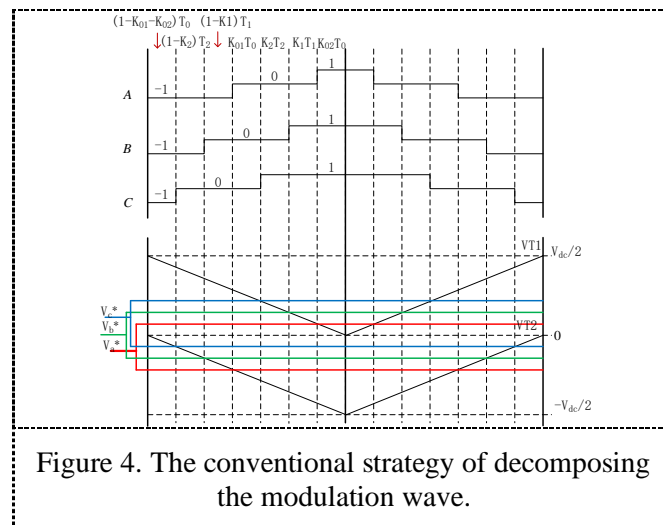

Figure 4. The conventional strategy of decomposing the modulation wave.

However, by comparing voltage-source converters and current-source converters, it can be found that the traditional equivalent relationship strategy applied to voltage-source multilevel converters is not applicable to CSCs. There are three reasons for this phenomenon:

- In the voltage source converter, each vector has multiple redundant level states, and each level state corresponds to one switching state, and the redundancy level state can be selected in the representation of the modulation sequence, then the corresponding switch state is obtained; while the current-source current vector of the current-mode converter only corresponds to a single level state, and at the same time corresponds to a large number of redundant switch states. The method of modulation wave equivalent is difficult to implement.

- Through the reasonable selection of the switching state, the voltage-source converter can ensure that only one switching tube operates in each switching cycle, and in the current-source converter, no matter how the switching state is selected, there must be multiple switches in each switching cycle. Because the upper and lower switches in the current-source converter do not have a complementary conduction relationship, the degree of modulation freedom is greatly increased.

- The level state of the voltage type inverter is simply increased and then decreased in one cycle. Therefore, by using the in-phase carrier and the modulated wave for comparison, the required modulation signal can be obtained, and the level state and The switching state of the current-source inverter does not have such a regularity in one cycle, which greatly increases the complexity of carrier modulation.

### 2.3. New decomposition method of modulation waves

Considering the above characteristics of the current-mode converter, this paper proposes a method for directly obtaining the state of the carrier modulation switch according to the state of the space vector level. The number of sub-modulation waves is determined according to the number of switches, and the PWM of the modulated wave is compared by the carrier. The signal is directly used as the switch state to control the on/off of the switch tube, and its rationality is proved by strict theoretical derivation. The decomposition principle is shown in Fig. 5.

In Fig. 5, the sub-modulation wave  $i_b^*$  is decomposed into four sub-modulation waves, and  $i_{b1}^*$ ,  $i_{b2}^*$ ,  $i_{b3}^*$ , and  $i_{b4}^*$  respectively control the B phase four switches  $S_{b1}$ ,  $S_{b2}$ ,  $S_{b3}$ , and  $S_{b4}$  to be disconnected, and VT1 and VT2 indicate shift phase carrier. The decomposition of the sub modulating waves is determined by the switching states shown in the lower part of Fig.5. For example,  $i_{b1}^*$  controls the on/off of  $S_{b1}$ . Since the switching state of  $S_{b1}$  is first broken and then turned on in the first half cycle,  $i_{b1}^*$  needs to be compared with VT1, and then the intersection of  $i_{b1}^*$  and carrier VT1 is further determined according to the effective time of the switching state. Determine the magnitude of  $i_{b1}^*$ , and finally denote  $i_{b1}^*$  as the form shown in  $i_{b1}^*$  in Fig. 5.

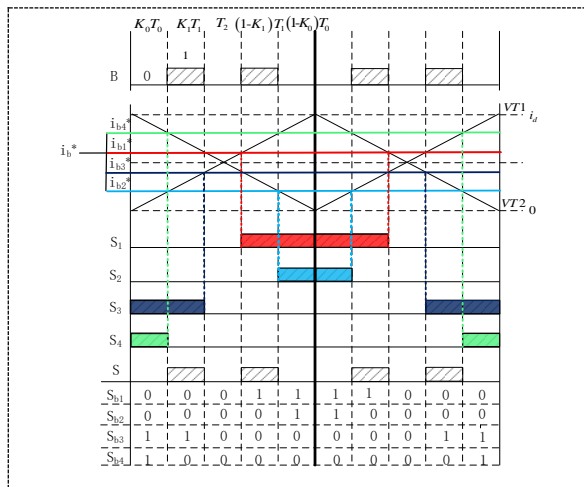

Figure 5. The novelty principle of decomposing the modulation wave.

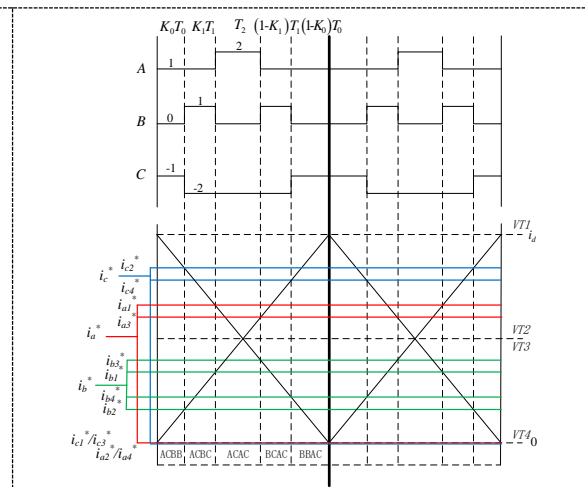

Figure 6. The equivalent principle between SVPWM and CBPWM in 10 segments sequence.

In order to prove the correctness of the decomposition strategy, it is only necessary to prove that the output level corresponding to the switch state after the decomposition is the same as the output of the original modulation sequence. The output level of the original modulation sequence is as shown by the grey shadow S. The output level of the modulated wave after decomposition is the shadows of S<sub>1</sub>, S<sub>2</sub>, S<sub>3</sub>, and S<sub>4</sub> in Fig.5, respectively. According to the area equivalent principle, there is obviously S=S<sub>1</sub>-S<sub>2</sub>+S<sub>3</sub>-S<sub>4</sub>, that is, the modulation effect before and after decomposition is equivalent.

#### 2.4. Five-level SVPWM output switching sequence is equivalent to CBPWM modulation

According to the previous introduction, the equivalent implementation of the five-level current-mode converter CBPWM modulation and SVPWM output switching sequence is derived as follows.

First, based on the principle of space vector modulation, the five-level current-type converter spatial vector modulation sequence has a maximum length of 10 segments. Using the new modulation wave decomposition method proposed in Section 2.3, based on the sequence of each switch state, the ABC three-phase modulated waves  $i_a$ ,  $i_b$ , and  $i_c$  are all decomposed into four sub-modulated waves, which are compared with the phase-shifted carriers VT1 and VT2 to obtain the final switch. Trigger signal to control the opening of 12 switch tubes. The modulation principle is shown in Fig. 6. The upper half of the figure, ABC, represents the output level of each phase in a single modulation cycle, and each unit level is  $i_d$ .

The core of the equivalent relationship lies in the derivation of the sub-modulation wave expression. Here, each current vector  $I_0$  ( $I_7, I_8, I_9$ ),  $I_1, I_2$  is defined, and the action time is  $T_0, T_1, T_2$ , respectively. Since the zero vector  $I_0$  contains 3 Redundant vector, the specific action time allocation of different zero vectors is realized by  $K_{01}, K_{02}$  and  $K_0$ , the value range is  $[0,1]$  and  $K_{01}+K_{02}+K_0=1$ ,  $K_0$  in the expression is  $(1-K_{01}-K_{02})$  indicates. The choice of K value has different meanings in CSC. According to the analysis of the circuit, different redundant zero vectors correspond to the same level output, but have different circulation loops. For example, when the  $I_7$  vector is selected, the freewheeling path is the A-phase switching tube. Therefore, changing the K value is actually changing the freewheeling path of the circuit at zero level, thereby changing the output characteristics of each phase switching tube. Based on Fig.6, the sub-modulation wave expression is obtained as follows.

According to the principle of equalization of the second:

$$\begin{cases} T_s i_{ab} = [(K_1 T_0) + 2T_2 + (1-K_1)T_0] i_d \\ T_s i_{bc} = [K_1 T_0 + 3K_2 T_1 + 2T_2 + 3(1-K_2)T_1 + (1-K_1)T_0] i_d \end{cases} \quad (1)$$

$i_{ab}$  represents the AB phase line current modulated according to the space vector in a modulation period,  $i_{ab}=i_a-i_b$ ;  $i_{bc}$  represents the BC phase current in a modulation period,  $i_{bc}=i_b-i_c$ . Combine  $T_s=T_0+T_1+T_2$  with (1), the values of  $T_0$ ,  $T_1$  and  $T_2$  can be got. Then, according to the simple geometric principle, the mathematical relationship between each sub-modulation wave and time  $T$  can be derived. Then by sub-modulation wave operation, the modulation waves of the upper and lower four switching tubes of each phase and the modulation wave expression of each of the upper and lower modules can be obtained. Take the phase A as an example:

$$\begin{cases} i_{a1}^* = \frac{1}{3}[(-K_1 - K_0 + 2)i_a + (-K_0 + 2K_1 - 1)i_b + (-K_1 + 2K_0 - 1)i_c + (6K_0 - 3)i_d] \\ i_{a3}^* = \frac{1}{3}[(K_1 + K_0)i_a + (-2K_1 + K_0)i_b + (K_1 - 2K_0)i_c + (-6K_0 + 3)i_d] \\ i_{a2}^* = i_{a4}^* = 0 \\ i_{ap}^* = i_{a1}^* - i_{a2}^* = \frac{1}{3}[(-K_1 - K_0 + 2)i_a + (-K_0 + 2K_1 - 1)i_b + (-K_1 + 2K_0 - 1)i_c + (6K_0 - 3)i_d] \\ i_{an}^* = i_{a3}^* - i_{a4}^* = \frac{1}{3}[(K_1 + K_0)i_a + (-2K_1 + K_0)i_b + (K_1 - 2K_0)i_c + (-6K_0 + 3)i_d] \end{cases} \quad (2)$$

The sub-modulation formulas represented by  $i_{a1}^* - i_{a4}^*$  in equation (2) are the final expressions of the carrier-modulated waves of the A-phase switching transistors, and only need to be compared with the corresponding carriers to obtain the switching state values of the respective switches. To achieve the same modulation effect as SVPWM;  $i_{ap}^*$  and  $i_{an}^*$  represent the total modulation voltage of the module on the A phase and the lower module.

The above derivation details the equivalent of the 10-switch full-switch sequence output in the  $D_{13}$  sector, and the derivation process for other sectors is similar. Since the 10-segment sequence is the most complex sequence in the space vector modulation of the five-level current-mode converter, the number of sub-modulations does not change with the reduction of the modulation sequence, but the expression will be simpler, the number of  $K$ -values and The value will also change accordingly. Therefore, in the five-level current-mode converter topology, the equivalent relationship between the 6-segment and the 8-segment can be derived by this method.

### 3. Simulation

In order to verify the accuracy of the proposed equivalent relationship method in the current-mode converter topology, the simulation verification is carried out on MATLAB.

The simulation experiment is based on a five-level CSC and the modulation degree is chosen to be  $m=0.7$  (guaranteed the linear modulation of the system and has a certain representativeness due to the relatively complex outer ring). Finally, the accuracy of the equivalent relationship method proposed in this paper can be verified by verifying whether the drive signal of each switch is consistent with the equivalent CBPWM drive signal under the SVPWM modulation strategy.

The waveforms shown in Figure 7-12 are based on the 10-segment modulation results for a five-level current-mode converter  $m=0.7$ . Fig. 7 shows the waveform of the modulation current  $i_a^*$  of the A phase and the modulation currents  $i_{ap}^*$  and  $i_{an}^*$  of the upper and lower modules after the decomposition using the equivalent modulation strategy. Fig. 8 shows four sub-modulation signals  $i_{a1}^*$ ,  $i_{a2}^*$ ,  $i_{a3}^*$ ,  $i_{a4}^*$  obtained by decomposing  $i_a^*$ . The final open-tube drive signal can be obtained by comparing four sub-modulation waves with the dual inverting carriers. The output level of phase A comparison is shown in Fig.9 and Fig.10.

Figure 11 and Figure 12 compares the output pulse of the space vector modulation switch with the output of the switch output pulse, and uses the output pulse of the A-phase switch. By comparing the simulated waveforms, it can be found that the output pulses of the two are consistent and have the same output characteristics, which proves the correctness of the equivalent method of CBPWM and SVPWM modulation effects proposed in this paper.





Figure 7. Waveforms of  $i_a^*$ ,  $i_{ap}^*$  and  $i_{an}^*$  with equivalent relationship method in 10 segments sequence

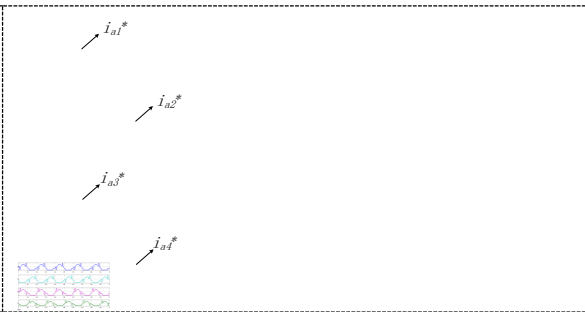

Figure 8. Waveforms of  $i_{a1}^*$ ,  $i_{a2}^*$ ,  $i_{a3}^*$  and  $i_{a4}^*$  with equivalent relationship method in 10 segments sequence.

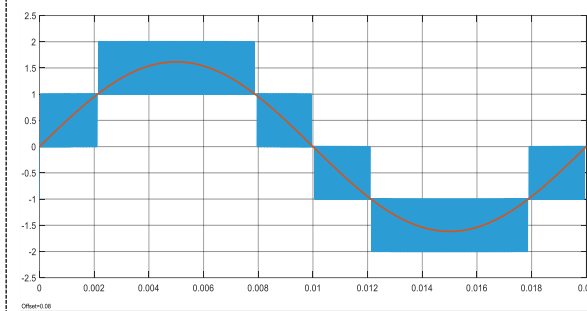

Figure 9. Waveform of phase A current and level states of phase A with SVPWM in 10 segments sequence

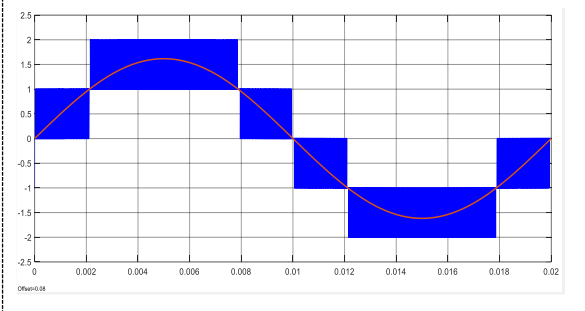

Figure 10. Waveform of phase A current and level states of phase A with equivalent relationship method in 10 segments sequence

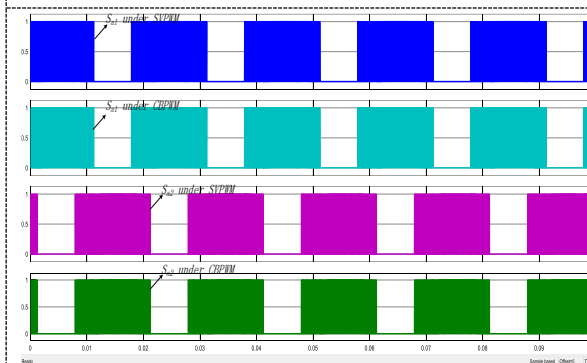

Figure 11. Comparison of switching states of  $S_{a1}$  and  $S_{a2}$  by two different modulation strategies.

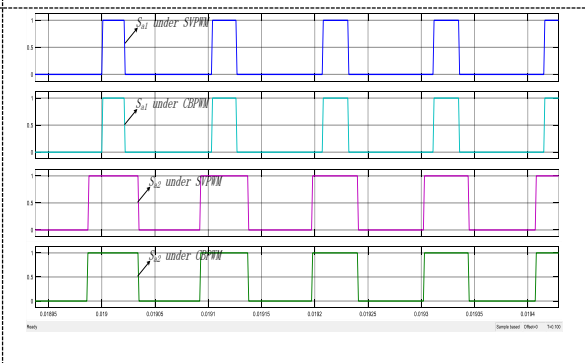

Figure 12. Comparison of switching states after partial enlargement of  $S_{a1}$  and  $S_{a2}$  by two different modulation strategies.

#### 4. Conclusion

In this paper, the equivalent relationship between the two main modulation modes SVPWM and CBPWM of current-type multilevel converter is studied in detail. According to the characteristics of no level state redundancy and many switching actions, a new modulation wave decomposition strategy is implemented to realize the equivalent of two modulation strategies, and the correctness of the method is verified by experiments. The method is simple and easy to implement, and has clear physical meaning. While retaining the space vector output characteristics of the five-level current-source converter, the complexity of the control method is greatly reduced. However, the method has not been extended to n level, which need further research and verification.

### Acknowledgments

This paper was supported by the National Natural Science Foundation of China (51777158), the Fundamental Research Funds for the Central Universities (1191329727), Delta Science and Education Development Fund(DREG2017011), Natural Science Basic Research Plan in Shaanxi Province of China(2018JM5008) and Science and Technology Research Plan in Xi'an city of China(201805034YD12CG18-2).

### References

- [1] Hu P, Teodorescu R, Wang S, et al. A Currentless Sorting and Selection-Based Capacitor-Voltage-Balancing Method for Modular Multilevel Converters[J]. IEEE Transactions on Power Electronics, 2018, 34(2):1-1.
- [2] Bessegato L, Ilves K, Harnefors L, et al. Effects of Control on the AC-Side Admittance of a Modular Multilevel Converter[J]. IEEE Transactions on Power Electronics, 2019, 34(8):1-1.
- [3] Verdugo C, Candela J I, Blaabjerg F, et al. Three-Phase Isolated Multi-Modular Converter in Renewable Energy Distribution Systems[J]. IEEE Journal of Emerging and Selected Topics in Power Electronics, 2019, PP(99):1-1.
- [4] Zhang, Ooi Z C, B.-T. Multimodular current-source SPWM converters for a superconducting magnetic energy storage system[J]. IEEE Transactions on Power Electronics, 2002, 8(3):250-256.
- [5] Li X L, Dong Z, Tse C K. Series-Connected Current-Source-Mode Multiple-Output Converters with High Step-Down Ratio and Simple Control[J]. IEEE Transactions on Power Electronics, 2019, PP(99):1-1. Bai Zhihong, Zhang Zhongchao. Research and Design of Three-Phase Multilevel Current Source Rectifier[J]. Transactions of China Electrotechnical Society, 2011, 26(7): 198-202.
- [6] Bai Zhihong, Zhang Zhongchao. Research and Design of Three-Phase Multilevel Current Source Rectifier[J]. Transactions of China Electrotechnical Society, 2011, 26(7): 198-202.
- [7] Gao H, Li Y, Wang S, et al. Losses analysis of soft magnetic ring core under sinusoidal pulse width modulation (SPWM) and space vector pulse width modulation (SVPWM) excitations[J]. Aip Advances, 2018, 8(5):056638.
- [8] Agrawal K, Gandhi A, Shah M T, et al. Design, analysis and realization of SVPWM using embedded code generation technique for a three phase, two level inverter[C]// International Conference on Electrical Power & Energy Systems. 2017.
- [9] Dong S, Zhang Q, Wang R, et al. Analysis of Capacitor Voltage Ripple for Bi-Directional Z-Source Inverters Based on SVPWM[J]. Transactions of China Electrotechnical Society, 2017, 32(24):107-114.
- [10] Yao, Wenxi, Hu, Haibing, Lu, Zhengyu. Comparisons of Space-Vector Modulation and Carrier-Based Modulation of Multilevel Inverter[J]. IEEE Transactions on Power Electronics, 2008, 23(1):45-51.
- [11] Chen Juan, He Yingjie, Hasan Saad, Liu Jinjun. A Comprehensive Study on Equivalent Modulation Waveforms of the SVM Sequence for Three-Level Inverters[J]. IEEE Transactions on Power Electronics, 2015, 30(12): 7149-7158.
- [12] Wang Chao, He Yingjie, Song Zhishun, Peng Cheng. Unified Theory between the Space Vector and the Triangular Carrier-Based PWM Strategies in Active Neutral-Point-Clamped Multilevel Inverters[J]. Transactions of China Electrotechnical Society, 2017, 32(14): 106-115.