



AALBORG UNIVERSITY
DENMARK

Aalborg Universitet

Fault protection method of single-phase break for distribution network considering the influence of neutral grounding modes

Xiao, Yang; Ouyang, Jinxin; Xiong, Xiaofu; Wang, Yutong; Luo, Yongjie

Published in:
Protection and Control of Modern Power Systems

DOI (link to publication from Publisher):
[10.1186/s41601-020-00156-w](https://doi.org/10.1186/s41601-020-00156-w)

Creative Commons License
CC BY 4.0

Publication date:
2020

Document Version
Publisher's PDF, also known as Version of record

[Link to publication from Aalborg University](#)

Citation for published version (APA):
Xiao, Y., Ouyang, J., Xiong, X., Wang, Y., & Luo, Y. (2020). Fault protection method of single-phase break for distribution network considering the influence of neutral grounding modes. *Protection and Control of Modern Power Systems*, 5(1), [10]. <https://doi.org/10.1186/s41601-020-00156-w>

General rights

Copyright and moral rights for the publications made accessible in the public portal are retained by the authors and/or other copyright owners and it is a condition of accessing publications that users recognise and abide by the legal requirements associated with these rights.

- ? Users may download and print one copy of any publication from the public portal for the purpose of private study or research.
- ? You may not further distribute the material or use it for any profit-making activity or commercial gain
- ? You may freely distribute the URL identifying the publication in the public portal ?

Take down policy

If you believe that this document breaches copyright please contact us at vbn@aub.aau.dk providing details, and we will remove access to the work immediately and investigate your claim.

ORIGINAL RESEARCH

Open Access



Fault protection method of single-phase break for distribution network considering the influence of neutral grounding modes

Yang Xiao¹, Jinxin Ouyang^{1*}, Xiaofu Xiong¹, Yutong Wang² and Yongjie Luo³

Abstract

With the rapid development of modern distribution network and the access of distributed generation, the network structure is becoming increasingly complex. Frequent single-phase break faults have seriously affected equipment and personal safety and stable operation of the power system. However, with the development and application of the composite neutral grounding modes, the protection of single-phase break fault is facing new challenges. This paper proposes a protection method of single-phase break fault for distribution network considering the influence of neutral grounding modes. The characteristics of neutral voltage and sequence current are analyzed under normal operation and single-phase break fault with different grounding modes. Following this, the protection criterion based on neutral voltage and sequence current variation is constructed. The protection method of single-phase break fault for distribution network is proposed, which is applicable for various neutral grounding modes. Theoretical analysis and simulation results show that the protection method is less affected by system asymmetry, fault location and load distribution. The method has higher sensitivity, reliability and adaptability.

Keywords: Distribution network, Single-phase break fault, Protection, Neutral grounding

1 Introduction

With the expansion of modern distribution network, the demand of power supply reliability is increasing.

However, the frequency of single-phase break fault is also increasing because of the complex structure of distribution network, the interlacing of old and new lines, and the influence of natural disasters, external mechanical forces or other reasons. Single-phase break fault causes unbalanced voltage between power supply side and load side, seriously affecting the power quality. Phase-deficient operation will also reduce equipment service life and damage motors [1]. If the fault is not discovered in time, it is very likely to develop into a short-circuit fault, increasing the severity of the accident and threatening personal safety [2, 3]. In addition, with the

access of distributed generation and electric vehicles, single-phase break fault will cause voltage to rise beyond the tolerance threshold of sensitive power electronic devices and damage it [4–6]. Therefore, the protection of single-phase break fault is especially important.

For a long time, single-phase break fault has not been paid enough attention because it will not cause high current and voltage. Reference [7–10] deduced the voltage and current characteristics of the ungrounded and grounded break fault of small current grounding system. Reference [11] used the positive sequence current modulus maximum to realize the line selection and location of the break fault, but did not consider the difference with the short-circuit fault and the influence of the actual noise on the signal processing. Reference [12] proposed a line selection method based on negative sequence current energy measurement, but its accuracy is greatly affected by the fault location and load distribution. Reference [13] proposed a combined line selection criterion of phase

* Correspondence: jinxinoy@163.com

¹School of Electrical Engineering, Chongqing University, Chongqing, China
Full list of author information is available at the end of the article

current and phase voltage, but only for ungrounded systems. According to the variation law of break fault voltage of ungrounded distribution network, the fault section location method based on phase voltage and line voltage is proposed in [14], but the influence of system asymmetry is not considered. Reference [15] used load monitors to collect negative sequence voltage to detect the break fault, but the data processing capacity was large. Reference [16] is based on the zero sequence voltage difference between the power supply side and load side of the fault line, but requires high communication and data synchronization.

On the one hand, the existing single-phase break fault protection method is greatly affected by system parameters and fault location, with limited accuracy and low reliability. On the other hand, since small current grounding mode is mostly adopted in distribution network, the existing methods are only applicable to the specific neutral grounding mode, and the low resistance grounding mode is not considered. However, with the acceleration of urbanization and the widespread use of cables, capacitance current is increasing, and the low resistance grounding mode is widely used. Definitely, there is a certain gap in the study of single-phase break fault in medium voltage distribution networks. And the intelligent multi-mode grounding, arc suppression coil with parallel resistance grounding and other modes are gradually applied to the distribution network [17–19], so that the neutral grounding mode may change during actual operation. The break fault protection methods under the specific neutral grounding mode are difficult to meet the requirements.

This paper proposes a protection method of single-phase break fault for distribution network considering the influence of neutral grounding modes. The method is basically not affected by the change of system parameters, fault location and load distribution, effectively improves

the protection sensitivity, and is applicable to various grounding modes. Firstly, considering the asymmetry of line parameters, this paper respectively deduces the expressions of the neutral voltage and sequence current of the normal operation and single-phase break fault under various grounding modes, and the variation characteristics before and after the fault are analyzed. On this basis, the neutral voltage and sequence current variation are extracted as the protection characteristic parameter and the protection criterion is constructed which is applicable for various grounding modes. Finally, the accuracy of the protection criterion in typical grounding modes is verified by simulation. The results show that the protection method has high reliability and wide applicability.

2 Distribution network operation characteristics considering three-phase asymmetry

The line parameters are related to not only the material, sectional area and insulating medium, but also the arrangement of conductors. In practice, the distribution network lines are short, and most of them are arranged horizontally or vertically, so that the phenomenon of three-phase capacitance unbalance is common [20]. The medium voltage distribution network generally operates in a radial mode. And the main transformer neutral point is mainly grounded in four ways: ungrounded, arc suppression coil grounded, low resistance grounded and arc suppression coil with parallel resistance grounded, as shown in Fig. 1. C_{iA} , C_{iB} , C_{iC} represent the three-phase capacitances to ground of the i th feeder. \dot{E}_A , \dot{E}_B , \dot{E}_C are transformer three phase induced electromotive force. \dot{I}_A , \dot{I}_B , \dot{I}_C are three phase current flowing into the bus from the upper-level grid. \dot{U}_O is neutral voltage. \dot{I}_O is

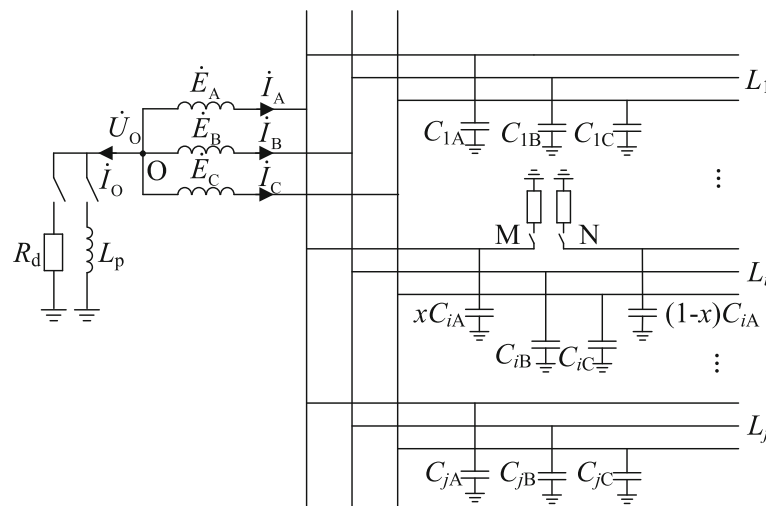

Fig. 1 Schematic diagram of distribution system

neutral branch current. R_d is neutral grounding resistance. L_p is arc suppression coil inductance.

2.1 Neutral voltage

Ignoring line impedance and distributed conductance to ground, there is

$$j\omega \sum_{i=1}^j [C_{iA}\dot{E}_A + C_{iB}\dot{E}_B + C_{iC}\dot{E}_C] + j\omega C_\Sigma \dot{U}_O + \dot{I}_O = 0 \quad (1)$$

Where, C_Σ is the sum of the three phase capacitances of the system.

Due to the asymmetry of the three-phase capacitance, the unbalanced voltage of the neutral point to ground \dot{U}_{unb} can be obtained as follow

$$\dot{U}_{unb} = \lambda \dot{E}_A \quad (2)$$

Where, λ is system asymmetry, depending on system parameters and grounding modes.

When the neutral point is ungrounded, the system asymmetry is

$$\lambda = \frac{C_{A\Sigma} + \alpha^2 C_{B\Sigma} + \alpha C_{C\Sigma}}{C_\Sigma} \quad (3)$$

When the neutral point is grounded by the arc suppression coil, the system asymmetry is

$$\lambda = \frac{C_{A\Sigma} + \alpha^2 C_{B\Sigma} + \alpha C_{C\Sigma}}{C_\Sigma - \frac{1}{\omega^2 L_p}} \quad (4)$$

When the neutral point is grounded by the low resistance, the system asymmetry is

$$\lambda = \frac{C_{A\Sigma} + \alpha^2 C_{B\Sigma} + \alpha C_{C\Sigma}}{C_\Sigma + \frac{1}{j\omega R_d}} \quad (5)$$

Where, $\alpha = e^{j120^\circ}$; ω is angular frequency; $C_{A\Sigma}$, $C_{B\Sigma}$, $C_{C\Sigma}$ are each phase capacitance of the system.

2.2 Sequence current

Asymmetry of the capacitance to ground of system will lead to the asymmetry of three-phase current. The feeder phase current is equal to the sum of the capacitance to ground current and load current. Consequently, the positive, negative and zero sequence current on the i th feeder are

$$\begin{cases} \dot{I}_{i1} = \frac{j\omega[\lambda(C_{iA} + \alpha C_{iB} + \alpha^2 C_{iC}) + C_{1\Sigma}]}{3} \dot{E}_A + \dot{I}_{i\text{load}} \\ \dot{I}_{i2} = \frac{j\omega[(\lambda + 1)C_{iA} + \alpha(1 + \alpha\lambda)C_{iB} + \alpha(\lambda + \alpha)C_{iC}]}{3} \dot{E}_A \\ \dot{I}_{i0} = \frac{j\omega[(\lambda + 1)C_{iA} + (\lambda + \alpha^2)C_{iB} + (\lambda + \alpha)C_{iC}]}{3} \dot{E}_A \end{cases} \quad (6)$$

Where, $\dot{I}_{i\text{load}}$ is load current of the i th feeder; $C_{i\Sigma} = C_{iA} + C_{iB} + C_{iC}$, where C_{iA} , C_{iB} , C_{iC} are each phase capacitance of the i th feeder.

Under the three-phase asymmetry of the distribution network, the neutral voltage shifts. At the same time, the negative and zero sequence current appear on feeders. Since the asymmetry of the distribution network is usually quite small, which is about 0.5% to 1.5%, and the cable has a smaller asymmetry than the overhead line. Therefore, the neutral voltage, negative and zero sequence current generated by the asymmetry can be ignored.

3 Single-phase break fault characteristics of distribution network

3.1 Neutral voltage

Suppose the feeder i has a single-phase break fault at the distance d from the bus. Compared with the normal operating condition, the single-phase break fault further deepens the asymmetry of the three-phase capacitor, so the neutral voltage will further shift. According to Kirchhoff's law, the current flowing through the neutral point satisfies

$$\dot{I}_A + \dot{I}_B + \dot{I}_C + \dot{I}_O = 0 \quad (7)$$

Where,

$$\begin{cases} \dot{I}_A = j\omega \left(xC_{iA} + \sum_{\substack{n=1 \\ n \neq i}}^j C_{nA} \right) (\dot{E}_A + \dot{U}_O) + \sum_{\substack{n=1 \\ n \neq i}}^j \dot{I}_{n\text{Aload}} \\ \dot{I}_B = j\omega C_{B\Sigma} (\dot{E}_B + \dot{U}_O) + \sum_{\substack{n=1 \\ n \neq i}}^j \dot{I}_{n\text{Bload}} \\ \dot{I}_C = j\omega C_{C\Sigma} (\dot{E}_C + \dot{U}_O) + \sum_{n=1}^j \dot{I}_{n\text{Cload}} \\ \dot{I}_O = \frac{\dot{U}_O}{Z_O} \end{cases} \quad (8)$$

Where, $\dot{I}_{n\text{Aload}}$, $\dot{I}_{n\text{Bload}}$, $\dot{I}_{n\text{Cload}}$ are three phase load currents of the n th feeder, $n = 1, 2, \dots, i, \dots, j$; Z_O is neutral grounding branch impedance.

When the neutral point is ungrounded, Z_O is infinity. Substituting eq. (8) into eq. (7), the neutral voltage after the single-phase break fault is

$$\dot{U}_O = \frac{j3(1-x)^2 Z_{Li} \omega C_{iA} + 3(1-x)}{j3Z_{Li} \omega C_{iA} (1-x)[(x+2) + 3(k-1)] + 6k} \dot{E}_A \quad (9)$$

Where, Z_{Li} is the load impedance of the fault feeder; $x = d/L_i$ is the ratio of the distance from the fault point to the bus to the length of the fault feeder L_i ; k is the ratio of total feeders capacitance to fault feeder capacitance.

$$k = \frac{C_\Sigma}{C_{iA} + C_{iB} + C_{iC}} \quad (10)$$

x reflects the degree of capacitance loss of the fault feeder, which is related to the fault location. k measures the degree of impact of a certain feeder single-phase break fault on the system, determined by the line parameters. Since $0 \leq x \leq 1$, the high order terms of $(1-x)$ are omitted, and eq. (9) can be simplified as:

$$|\dot{U}_O| = \frac{1-x}{2k} |\dot{E}_A| \quad (11)$$

When neutral point is grounded by the arc suppression coil, $Z_O = j\omega L_p$, the neutral voltage after single-phase break fault is

$$\dot{U}_O = \frac{-(1-x) - j(1-x)^2 Z_{Li} \omega C_{iA}}{2pk + j\omega C_{iA} Z_{Li} (1-x)(3kp - x + 1)} \dot{E}_A \quad (12)$$

Similarly, eq. (12) can be simplified as

$$|\dot{U}_O| = \frac{1-x}{2pk} |\dot{E}_A| \quad (13)$$

Where, p is the overcompensation degree of the arc suppression coil.

When neutral point is grounded by the low resistance, $Z_O = 1/R_d$, the neutral voltage after single-phase break fault is

$$\dot{U}_O = \frac{-3(1-x)^2 Z_{Li} R_d \omega^2 C_{iA}^2 + j3(1-x) R_d \omega C_{iA}}{2 - j\omega C_{iA} [6kR_d + 3Z_{Li}(1-x)]} \dot{E}_A \quad (14)$$

Similarly, eq. (14) can be simplified as

$$|\dot{U}_O| = \frac{3R_d \omega C_{iA} (1-x)}{2} |\dot{E}_A| \quad (15)$$

It can be seen from eq. (11), (13) and (15) that the neutral voltage is mainly affected by the single-phase break fault location, the grounding mode and parameters of neutral point, and the proportion of the line capacitance.

3.2 Sequence current

The single-phase break fault causes the fault phase current at the fracture to be 0, and the non-fault phase voltage is continuous at the front and back of the fracture. When phase A is broken, using the symmetrical component method [21], the boundary condition is

$$\begin{cases} \dot{I}'_{A1} + \dot{I}'_{A2} + \dot{I}'_{A0} = 0 \\ \Delta \dot{U}'_{A1} = \Delta \dot{U}'_{A2} = \Delta \dot{U}'_{A0} \end{cases} \quad (16)$$

Where, \dot{I}'_{A1} , \dot{I}'_{A2} , \dot{I}'_{A0} are positive, negative and zero sequence current at the fracture; $\Delta \dot{U}'_{A1}$, $\Delta \dot{U}'_{A2}$, $\Delta \dot{U}'_{A0}$ are positive, negative and zero sequence voltage difference across the fracture.

The impedance of distribution line and system are very small and can be ignored. The zero-sequence load impedance can be approximated to infinity. According to eq. (16), the composite sequence network in case of phase-A break fault of feeder i can be established as shown in Fig. 2(a). \dot{I}_{A1} , \dot{I}_{A2} , \dot{I}_{A0} are positive, negative and zero sequence current at the outlet of the fault feeder; Z_{eq1} , Z_{eq2} are positive and negative sequence equivalent impedance of all non-fault feeders; C_{eq0} is the equivalent zero sequence capacitance for all non-fault feeders; C_{iA1} , C_{iA2} , C_{iA0} are positive, negative and zero sequence capacitance of the fault feeder; Z_{iM1} , Z_{iM2} are the positive and negative sequence load impedance of the upstream of the fault feeder respectively; Z_{iN1} , Z_{iN2} are the positive and negative sequence load impedance of the downstream of the fault feeder.

Figure 2(b) is a simplified circuit of the composite sequence network. Where Z_2 is the equivalent impedance of the negative sequence network; Z_{M1} and Z_{N1} are the positive sequence equivalent impedances of the fault feeder at the front and back of the fracture.

$$Z_{M1} = Z_{iM1} // (1/j\omega x C_{iA1}) \quad (17)$$

$$Z_{N1} = Z_{iN1} // [1/j\omega(1-x)C_{iA1}] \quad (18)$$

Solving the simplified circuit, the sequence current at the fracture is

$$\begin{cases} \dot{I}'_{A1} = \frac{Z_2 + Z_0}{Z_{N1}Z_0 + Z_{N1}Z_2 + Z_2Z_0} \dot{E}_A \\ \dot{I}'_{A2} = \frac{-Z_0}{Z_{N1}Z_0 + Z_{N1}Z_2 + Z_2Z_0} \dot{E}_A \\ \dot{I}'_{A0} = \frac{-Z_2}{Z_{N1}Z_0 + Z_{N1}Z_2 + Z_2Z_0} \dot{E}_A \end{cases} \quad (19)$$

And the sequence current at the outlet of the fault feeder is

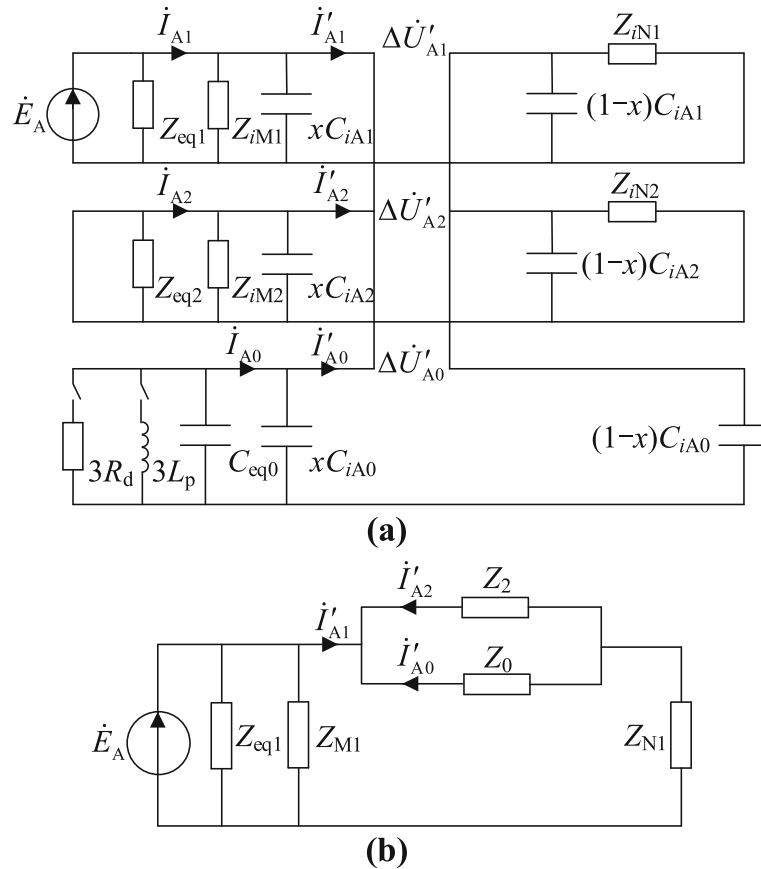

Fig. 2 Composite sequence network of single-phase break fault (a) Composite sequence network (b) Equivalent circuit

$$\begin{cases} I_{A1} = \left(\frac{Z_2 + Z_0}{Z_{N1}Z_0 + Z_{N1}Z_2 + Z_2Z_0} + \frac{1}{Z_{M1}} \right) \dot{E}_A \\ I_{A2} = \dot{I}'_{A2} = \frac{-Z_0}{Z_{N1}Z_0 + Z_{N1}Z_2 + Z_2Z_0} \dot{E}_A \\ I_{A0} = \left[1 - \frac{3Z_0 // (1/j\omega C_{eq0}) // (1/j\omega x C_{iA0})}{(1/j\omega x C_{iA0})} \right] \dot{I}'_{A0} \end{cases} \quad (20)$$

It can be seen from eq. (19) and (20) that the amplitude and phase of the sequence current at the fracture is affected by the single-phase break fault location, and network parameters. And the sequence current at the outlet of the fault feeder is also affected by load distribution.

The deviation of neutral voltage is different under different grounding mode, no matter in normal operation or single-phase break fault. According to eq. (3) to (5), the system asymmetry is minimum when grounded by low resistance, and is maximum when grounded by arc suppression coil. Furthermore, the smaller the over-compensation degree is, the larger the deviation is. The amplitude of the feeder sequence current mainly depends on the asymmetry under normal operation, and

depends on the system parameters under single-phase break fault. As a result, the sequence current under different neutral grounding modes also shows a certain difference. Therefore, in order to improve the applicability of protection, it is necessary to consider the influence of the neutral grounding mode.

4 Single-phase break fault protection method for distribution network

4.1 Protection characteristic parameter

From eq. (3) to (5) and eq. (9) to (15), it can be seen that the neutral voltage and feeder sequence current under normal operation and single-phase break fault of the distribution network are significant different when the grounding mode is different. The neutral voltage is affected by x and k after the single-phase break fault, and has a maximum value.

When the neutral point is ungrounded, combined with eq. (11), the maximum variation of the neutral voltage is

$$U_{Omax} = \frac{1}{2k_{min}} U_\phi \quad (21)$$

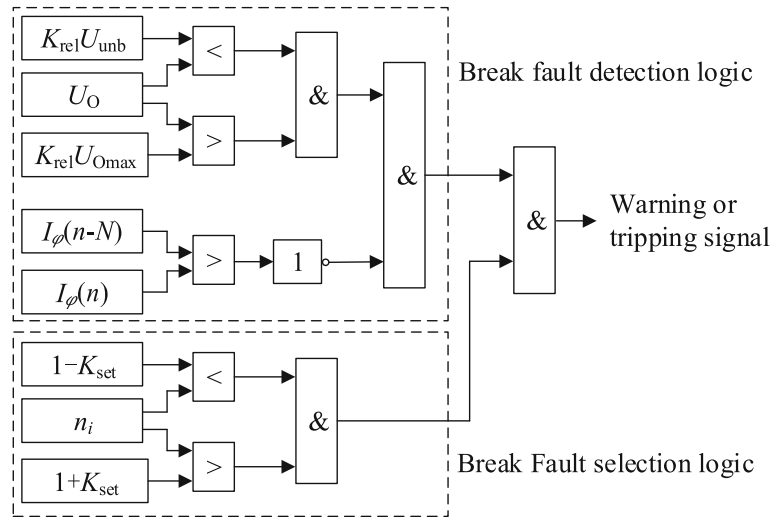

Fig. 3 Logic diagram of single-phase break fault protection

When the neutral point is arc suppression coil grounded, combined with eq. (13), the maximum variation of the neutral voltage is

$$U_{Omax} = \frac{1}{2pk_{min}} U_{\phi} \quad (22)$$

When the neutral point is low resistance grounded, combined with eq. (15), the variation maximum of the neutral voltage is

$$U_{Omax} = \frac{3R_d\omega C_{max}}{2} U_{\phi} \quad (23)$$

Where, k_{min} is the ratio of system capacitance to maximum feeder capacitance; C_{max} is maximum capacitance to ground in all feeders; U_{ϕ} is normal operating phase voltage.

Since the sequence current under normal operation is very small, combined with the eq. (19), the positive and negative sequence current changes at the outlet of the fault feeder before and after the single-phase break fault are

$$\begin{cases} \Delta I_{iA1} = I'_{A1} - \frac{\dot{E}_A}{Z_{N1}} = -\frac{Z_0}{Z_{N1}Z_0 + Z_{N1}Z_2 + Z_2Z_0} \dot{E}_A \\ \Delta I_{iA2} = I'_{A2} - 0 = -\frac{Z_0}{Z_{N1}Z_0 + Z_{N1}Z_2 + Z_2Z_0} \dot{E}_A \end{cases} \quad (24)$$

According to eq. (24), the changes of the positive and negative sequence currents are equal before and after the single-phase break fault. Moreover, since the difference in the grounding mode only affects the zero-sequence impedance, the relationship of the positive and negative sequence current variations is always

established in various grounding modes, which is independent of the zero sequence impedance.

Before and after the single-phase break fault, the non-fault feeder positive sequence current change is 0, and the negative sequence current change is

$$\Delta I_{jA2} = I'_{A2} \frac{Z_{S2}}{Z_{eq2} + Z_{S2}} \quad (25)$$

Where, Z_{S2} is the system negative sequence equivalent impedance.

The negative sequence current mostly flows from the fault feeder to the upper grid since the negative sequence equivalent impedance of the medium voltage distribution network system is much smaller than the line negative sequence impedance [11]. As a consequence, the negative sequence current on the non-fault feeder is much lower than that of the fault feeder. The ratio of positive and negative sequence current change of the non-fault feeder is less than 1.

Therefore, the neutral voltage and the sequence current variation are selected as the protection characteristic parameter, which can accurately reflect the occurrence of the single-phase break fault and distinguish the fault feeder from the non-fault feeder.

4.2 Protection criterion

This paper proposes a protection method of single-phase break fault for distribution network considering the influence of neutral grounding modes. In view of the significant change of the neutral voltage before and after the fault, it is selected as the starting criterion, which can quickly reflect the occurrence of the single-phase break fault. The expression is

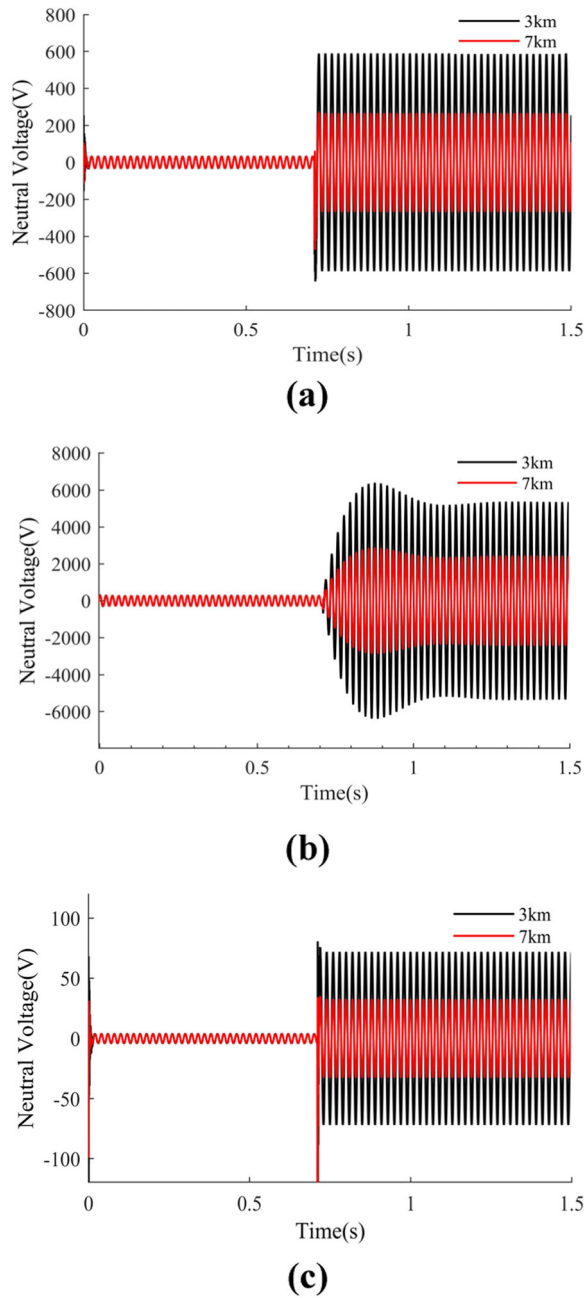

Fig. 4 Neutral voltage under different grounding modes (a) Ungrounded (b) Arc suppression coil grounded (c) Low resistance grounded

$$K_{rel}U_{unb} < U_O < K_{rel}U_{O\ max} \tag{26}$$

Where, K_{rel} is reliability coefficient.

Nonetheless, some short-circuit faults will also cause the neutral voltage to shift. However, the single-phase break fault does not cause a rise in current. Selecting the bus phase current as the blocking criterion can effectively distinguish the single-phase break fault from the

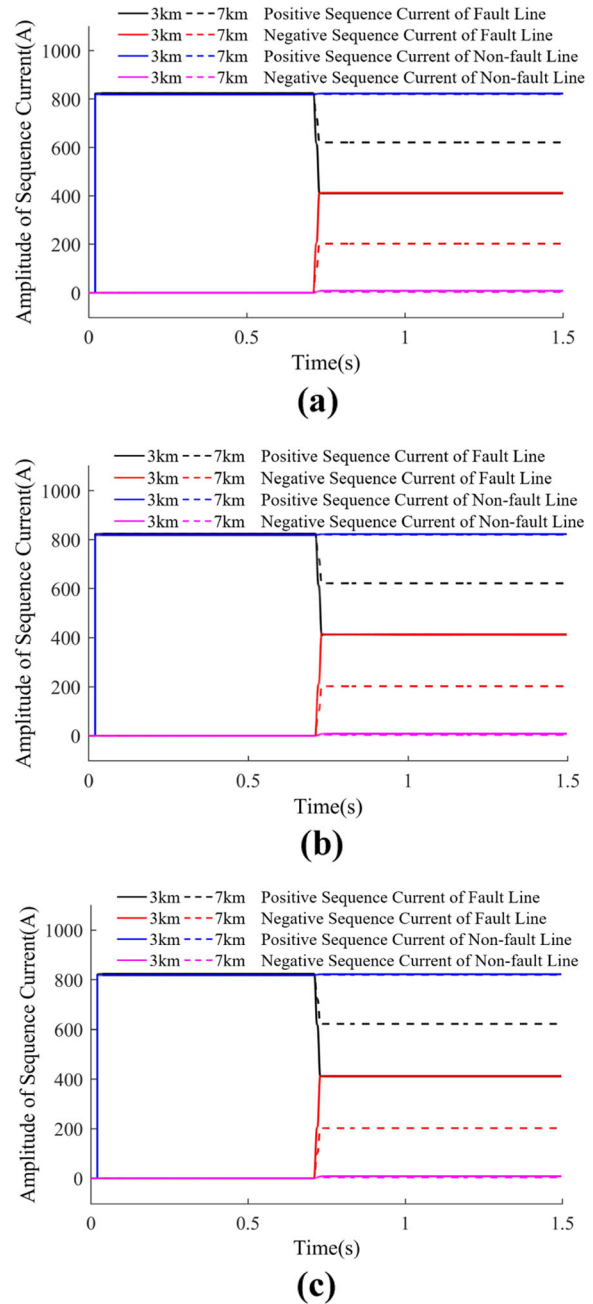

Fig. 5 Positive and negative sequence current under different grounding modes (a) Ungrounded (b) Arc suppression coil grounded (c) Low resistance grounded

short-circuit fault. Considering the light or no load of the line, the expression is

$$I_{\varphi}(t) - I_{\varphi}(t-T) \leq 0 \tag{27}$$

Where, $I_{\varphi}(t)$ is the sample value of bus phase current at the present moment; $I_{\varphi}(t-T)$ is the sample value of bus phase current at the previous cycle.

Table 2 Neutral voltage variation with fault location

Fault location (km)	Neutral voltage (V)		
	Ungrounded	Arc suppression coil grounded	Low resistance grounded
1	531.69	5176.02	64.96
2	475.16	4631.55	58.05
3	418.64	4101.22	51.15
4	362.12	3528.46	44.24
5	305.61	2941.56	37.34
6	245.59	2390.02	30.00
7	189.92	1845.55	23.20
8	134.30	1311.68	16.40
9	78.79	767.21	9.62

Based on the different variation characteristics, the ratio of positive and negative sequence current variation is used to construct the line selection criterion, which can accurately distinguish the fault feeder from the non-fault feeder. The expression is

$$1 - K_{\text{set}} < n_i < 1 + K_{\text{set}} \quad (28)$$

Where, n_i is the ratio of the positive and negative sequence current amplitude variation at the outlet of the feeder i ; K_{set} is the margin, generally 0.1~0.2 (It is required that the setting of K_{set} can clearly identify the fault feeder. Taking the influence of asymmetry degree, measurement error and noise into account, it is more appropriate to take $K_{\text{set}} = 0.1$).

In addition, the blocking criterion is mainly used to distinguish short-circuit faults and break faults. The protection of short-circuit fault is generally quick-acting. Therefore, a certain time delay can be set, which can not

only cooperate with short circuit fault protection, but also realize segment protection of the line.

According to the eq. (26) to (28), the single-phase break fault protection method of the distribution network is as shown in Fig. 3, including the starting component, the line selection component, and the blocking component.

The specific action logic is: when the neutral voltage is higher than the normal unbalanced voltage and less than the maximum voltage of the single-phase break fault, the starting component acts; when the amplitude of the bus phase current increases, the blocking component acts to prevent misjudgment, otherwise, the blocking component does not act, determining that the single-phase break fault occurs; when a certain feeder i satisfies $1 - K_{\text{set}} < n_i < 1 + K_{\text{set}}$, the line selection component acts and sends the warning or tripping signal, determining that the feeder does have a single-phase break fault.

When the neutral point is grounded in different ways, it is only necessary to adjust the minimum and

**Fig. 6** Bus phase current variation with fault location

Table 1 Line parameters

Feeder number	Length (km)	Capacitance (μF/km)		
		A	B	C
1	10	0.26	0.28	0.27
2	8	0.30	0.30	0.31
3	9	0.27	0.27	0.27
4	7	0.32	0.31	0.33
5	6	0.29	0.29	0.28
6	5	0.30	0.30	0.30

maximum values of the neutral voltage corresponding to the starting criterion without changing the protection principle, while the blocking criterion and line selection criterion are fixed. Therefore, this protection method is applicable to any grounding modes.

For fault phase selection, it can be achieved in the following two ways. First, since the fault phase voltage is larger than the non-fault phase voltage [14, 16], phase selection can be realized by comparing the phase voltages. Second, the non-fault phase current is continuous after the single-phase break fault, while the fault phase current is discontinuous, which is equal to the upstream load current and changes more significantly [13]. Therefore, the fault phase selection can be realized by comparing the change of the phase current.

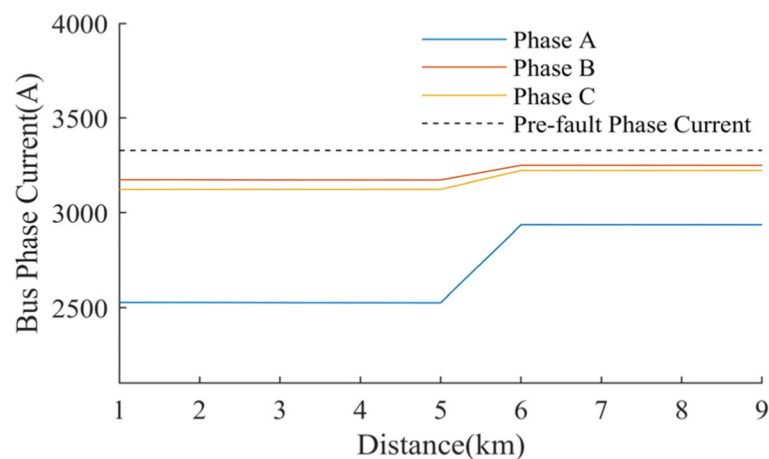
5 Simulation and results

In order to verify the reliability of the proposed protection method under the ungrounding, arc suppression coil grounded and low resistance grounded modes, the 10 kV typical structural distribution network model shown in Fig. 1 is built in Matlab/Simulink. There are 6 feeders in the distribution network. The neutral low resistance R_d is 10 Ω, and the arc suppression coil is overcompensated by 10%. The line parameters are shown in Table 1.

From Table 1, according to the numerical analysis, when the neutral point is ungrounded, the asymmetry is 0.43%, the U_{unb} is 24.8 V in normal operation, and the U_{Omax} is 600 V in single-phase break fault. When the neutral point is arc suppression coil grounded, the asymmetry is 4.3%, the U_{unb} is 248.3 V, and the U_{Omax} is 5989 V. When the neutral point is low resistance grounded, the asymmetry is 0.05%, the U_{unb} is 2.9 V, and the U_{Omax} is 76 V.

According to eq. (26) to (28), take $K_{rel} = 1.1$, $K_{set} = 0.1$, and the protection criterion when ungrounded is

$$\begin{cases} 27 < U_O < 660 \\ I_\varphi(t) - I_\varphi(t-T) \leq 0 \\ 0.9 < n_i < 1.1 \end{cases} \quad (29)$$

and when arc suppression coil grounded is

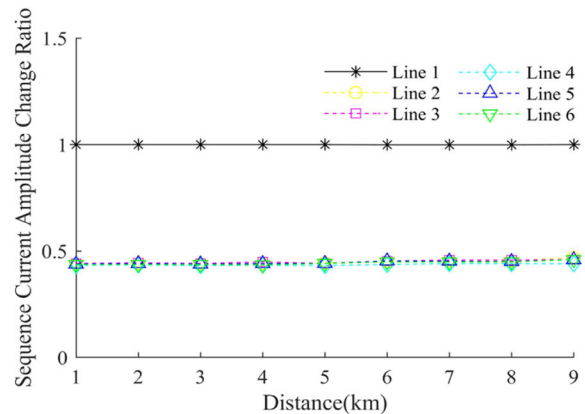

(a)

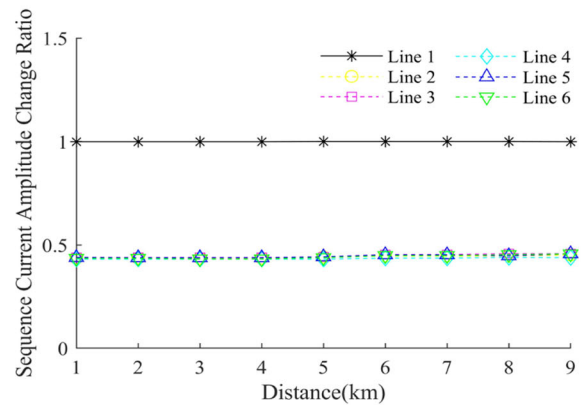

(b)

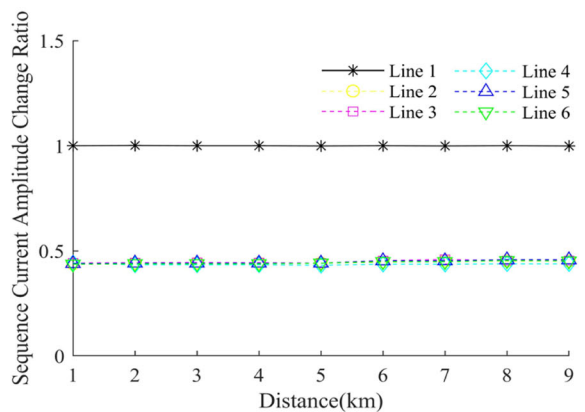

(c)

Fig. 7 Positive and negative sequence current amplitude change ratio variation with fault location (a) Ungrounded (b) Arc suppression coil grounded (c) Low resistance grounded

Table 3 Influence of system asymmetry on neutral voltage and sequence current ratio

Group	Ungrounded				Arc suppression coil grounded				Low resistance grounded			
	$\lambda(\%)$	$U_{unb}(V)$	$U_O(V)$	n_1	$\lambda(\%)$	$U_{unb}(V)$	$U_O(V)$	n_1	$\lambda(\%)$	$U_{unb}(V)$	$U_O(V)$	n_1
1	0	0.28	410.55	1	0	2.26	4016.37	1	0	0	48.31	1
2	0.29	16.05	412.44	1	2.88	113.27	4058.79	1	0.03	1.97	50.10	1
3	0.43	23.86	418.64	1	4.30	235.21	4101.22	1	0.05	2.91	51.15	1
4	0.83	45.61	437.84	1	8.25	403.05	4115.36	1	0.09	5.59	53.46	1
5	1.10	60.88	454.32	1	10.9	551.54	4131.93	1	0.12	7.42	55.15	1

$$\begin{cases} 273 < U_O < 6588 \\ I_\varphi(t) - I_\varphi(t-T) \leq 0 \\ 0.9 < n_i < 1.1 \end{cases} \quad (30)$$

and when low resistance grounded is

$$\begin{cases} 3 < U_O < 84 \\ I_\varphi(t) - I_\varphi(t-T) \leq 0 \\ 0.9 < n_i < 1.1 \end{cases} \quad (31)$$

The load of feeder 1 is set at 5 km and 10 km. The feeder 1 has a phase-A single-phase break fault at 3 km and 7 km from the bus respectively when $t = 0.7$ s. The neutral voltages at different fault locations are shown in Fig. 4. The neutral voltage rises significantly after the single-phase break fault. And the positive and negative sequence currents are shown in Fig. 5. The drop amplitude of the positive sequence current is similar to the rise amplitude of the negative sequence current on fault feeder, whereas the sequence current of the non-fault feeder has little change.

Change the fault location from 1 km to 9 km, and the corresponding neutral voltage is shown in Table 2. It can be seen that the neutral voltage is related to the fault location and grounding mode. The closer the fault distance is to the bus, the higher the neutral voltage is. And the voltage is the highest when arc suppression coil grounded, and the lowest when low resistance grounded. In contrast to eq. (29) to (31), the neutral voltage is

within the range of the criterion, and the protection can be started reliably.

The change of bus phase current is shown in Fig. 6. It can be seen that the current of each phase is influenced by load distribution, and the closer the fault location is to the bus, the more the phase current drops. But each phase current is always lower than the normal running phase current. Among them, the phase-A current is the smallest, so it can be determined that the fault phase is the phase A. The blocking criterion does not work. Combined with the starting criterion, it can reliably judge the occurrence of single-phase break fault.

The ratio of the positive and negative sequence current amplitude changes of each feeder variation with the fault location is shown in Fig. 7. In different grounding modes, there are always $n_1 \approx 1$ for the fault feeder, and $n_i < 0.5 (i \neq 1)$ for non-fault feeders, which have obvious boundaries. Therefore, the line selection criterion is not affected by the grounding modes and fault location, and the fault line can be accurately and reliably selected.

At the same fault location ($d = 3$ km), the neutral voltage and the positive and negative sequence current amplitude change ratio of the fault feeder under different system asymmetry can be obtained by changing the three-phase capacitance to ground of feeders, as shown in Table 3. With the increase of the system asymmetry, the neutral voltage tends to increase whether in normal operation or single-phase break fault state, but the change of amplitude is small. All of them are within the

Table 4 Single-phase break fault with high resistance grounding

Grounding resistance(Ω)	Ungrounded				Arc suppression coil grounded				Low resistance grounded			
	n_1		$U_O(V)$		n_1		$U_O(V)$		n_1		$U_O(V)$	
	MG	NG	MG	NG	MG	NG	MG	NG	MG	NG	MG	NG
Pure resistance	700	1.0	700.1	527.2	1.0		5011.3	4916.5	1.0		83.7	63.8
	1000		613.8	476.2			4871.9	4687.9			74.5	57.7
	1500		513.4	445.8			4651.3	4435.2			62.4	54.1
	2000		473.2	434.5			4539.6	4138.4			57.6	52.8
Arc resistance	700	1.0	656.2	491.4	1.0		4702.3	4625.5	1.0		78.5	56.2
	1000		548.4	456.1			4468.9	4302.1			66.1	53.5
	1500		480.8	435.7			4256.8	4189.6			58.2	52.0
	2000		455.4	428.5			4186.7	4125.9			55.2	51.6

Table 5 Comparison of the line selection criterias

Fault location (km)	Negative sequence current(A)	Sequence current changes ratio
0	450.6	1.0
2	350.3	1.0
4	253.5	1.0
6	163.2	1.0
8	78.9	1.0
10	74.6	1.0

range of the starting criterion, and the protection can be reliably initiated. Moreover, the positive and negative sequence current amplitude change ratio of the fault feeder is basically unaffected. The line selection criterion can still accurately identify the single-phase break fault feeder, which has high reliability.

The single-phase break fault may also be accompanied by a grounding fault. In order to adapt to a variety of complex break faults, the power supply side and the load side are grounded by resistance and arc resistance respectively at the break fault location ($d = 3$ km). The protection characteristic parameters are shown in Table 4, where MG represents the terminal M (the power supply side) is grounded, and NG represents the terminal N (the load side) is grounded. It can be seen that the additional grounding fault exacerbates the deviation of the neutral voltage, the neutral voltage decreases with the increase of the grounding resistance, and gradually approaches the value under the ungrounding break fault. The ratio of the positive and negative sequence current amplitude changes is always 1.0, which guarantees the accuracy of the line selection criteria. Therefore, the protection method is also applicable to the break fault with high resistance grounding.

The negative sequence current method is the most commonly used existing method, and its setting value needs to avoid the maximum negative sequence current of the line when a single-phase break fault occurs on other lines. However, the negative sequence current is greatly affected by the fault location, the size and distribution of the load, and the system impedance. The load is evenly distributed on feeder 1. Make a comparison between the proposed criterion and the negative sequence current criterion. It can be seen from Table 5 that as the

fault distance increases, the negative sequence current decreases. When the fault occurs at the end of the feeder, the negative sequence current is lower than the setting value 77A, causing the negative sequence current protection refuses to act. But n_1 is always about 1.0, which is within the action range of the selection criterion. Therefore, compared with the negative sequence current criterion, the proposed protection criterion is simpler to set, and can accurately distinguish short circuit fault from the break fault, which has higher reliability and applicability.

When a single-phase grounding fault, two-phase short circuit fault and the load disappearance occur on feeder 1 respectively, the change of protection characteristic parameters are shown in Table 6. Combining eq. (29) to (31), it can be known that in the case of other fault types or changes in operating conditions, the system neutral voltage and the bus phase current changes cannot meet the starting criterion and the blocking criterion at the same time. The line selection criterion does not work. Therefore, the protection method can accurately distinguish the single-phase break fault and other conditions.

6 Discussion

It can be seen from the above simulation results that the proposed protection method has the following advantages. This method can reliably identify the fault type, accurately select the fault line, and is weakly affected by the fault location and load changes. Compared with the existing methods, it has higher reliability, and is suitable for various neutral grounding modes, which is better adapted to the development of modern distribution network. However, this method also has some limitations.

Table 6 Protection characteristic parameters in other cases

Type	Ungrounded			Arc suppression coil grounded			Low resistance grounded		
	$U_0(V)$	$\Delta I_\phi(A)$	n_1	$U_0(V)$	$\Delta I_\phi(A)$	n_1	$U_0(V)$	$\Delta I_\phi(A)$	n_1
Single phase grounding	5523.9	25.1	0.34	5482.7	5.2	0.86	5345.3	454.5	0.93
Two-phase short circuit	16.3	21,607	1.04	141.7	21,607	1.04	2.0	21,607	1.04
Load disappearance	23.8	-804.1	5426.7	216.4	-804.1	5426.7	2.9	-804.1	5426.7

Because the non-fault line has a very small negative sequence current, it requires a higher sensitivity to the current acquisition device. The smaller the line capacitance and the farther the fault location is, the weaker characteristics of the neutral voltage change will be. However, with the extensive application of cables, the capacitance of distribution network becomes larger and larger, so the neutral voltage characteristics of the single-phase break fault are stronger. Therefore, the sensitivity and applicability of the method can be guaranteed.

7 Conclusion

In this paper, the neutral voltage and sequence current variation characteristics of distribution network single-phase break fault under typical grounding modes are studied, and a fault protection method of single-phase break considering the influence of neutral grounding modes is proposed. The protection principle is based on the fact that the neutral voltage change is significant before and after the fault and the positive and negative sequence current amplitude changes of the fault feeder are equal, which have a great difference from non-fault feeders. In addition, the criterion of bus phase current is added to distinguish single-phase break and short-circuit fault, which can reliably identify the occurrence of single-phase break fault and accurately select the fault line. This protection method is simple to set, and is basically not affected by the fault location, load distribution and system asymmetry, which has high sensitivity and reliability, and is applicable for various grounding modes.

Acknowledgements

Not applicable.

Authors' contributions

Yang Xiao performed the study of the method, analyzed the data and draft the manuscript. Jinxin Ouyang and Xiaofu Xiong engaged in modifying the paper and submitted it to the PCMP. Yutong Wang and Yongjie Luo participated in the design and simulation model building. All authors read and approved the final manuscript.

Authors' information

Yang Xiao(1997-), female, master student, major in power system protection and control. Email: yangxiao_ee@163.com. **Jinxin Ouyang**(1984-), male, PHD and Professor, major in analysis, protection, and control of renewable energy integrated power system. Email: jinxinoy@163.com.

Xiaofu Xiong(1962-), male, PHD and Professor, major in power system optimal operation and control and smart grid. Email: cquxf@vip.sina.com.

Yutong Wang(2000-), female, student, major in power system automation. Email: 187181713@qq.com.

Yongjie Luo(1988-), male, PHD, major in flexible DC transmission control and protection. Email: jieyong@163.com.

Funding

This work was supported by the National Natural Science Foundation of China (NO. 51877018).

Availability of data and materials

Not applicable.

Competing interests

The authors declare that they have no competing interests.

Author details

¹School of Electrical Engineering, Chongqing University, Chongqing, China.

²North China Electric Power University, Beijing, China. ³Aalborg University, Aalborg, Denmark.

Received: 12 November 2019 Accepted: 4 March 2020

Published online: 01 April 2020

References

- Campbell, M., & Arce, G. (2018). Effect of motor voltage unbalance on motor vibration: Test and evaluation. *IEEE Transactions on Industry Applications*, *54*(1), 905–911.
- Singh, M. (2017). Protection coordination in distribution systems with and without distributed energy resources- a review. *Protection and Control of Modern Power Systems*, *2*(1), 27.
- Yu, S., & Pan, L. (2009). Analysis of not-short circuit faults in neutral indirectly grounding system. *Power System Protection and Control*, *37*(20), 74–78.
- Telukunta, V., Pradhan, J., Agrawal, A., Singh, M., & Srivani, S. G. (2017). Protection challenges under bulk penetration of renewable energy resources in power systems: A review. *CSEE Journal of Power and Energy Systems*, *3*(4), 365–379.
- Liu, Y., Meliopoulos, A. P., Sun, L., & Choi, S. (2018). Protection and control of microgrids using dynamic state estimation. *Protection and Control of Modern Power Systems*, *3*(1), 31.
- Singh, M., Vishnuvardhan, T., & Srivani, S. G. (2016). Adaptive protection coordination scheme for power networks under penetration of distributed energy resources. *IET Generation Transmission and Distribution*, *10*(15), 3919–3929.
- Shi, F., & Cong, W. (2014). Methodology to differentiate type of single-phase line break fault in 10kV ungrounded distribution networks. In *IEEE PES Asia-Pacific power and energy engineering conference* (pp. 1–6).
- Wang, R., Cong, W., Kang, Q., Liu, G., Wang, H., & Yi, R. (2015). Analysis on single-phase line break fault of 10kV non-grounded distribution network. In *International conference on electric utility deregulation and restructuring and power technologies* (pp. 1043–1049).
- Lzykowski, J., Rosolowski, E., & Pierz, P. (2015). Location of open conductor failure combined with phase-to-earth fault on power line. In *International conference on computational problems of electrical engineering* (pp. 56–58).
- Huang, S., Li, T., Ding, F., & Yang, L. (2011). A new calculation method for open-phase fault based on superposition principle. In *International conference on advanced power system automation and protection* (pp. 1139–1143).
- Zhu, L., Zhang, Z., Wang, Z., Zhang, H., Li, C., Zhu, S., & Bai, Y. (2011). Single-phase open-line fault selection and location based on wavelet neural networks. *Power System Protection and Control*, *39*(04), 12–17.
- Zhu, L., Li, C., Zhang, H., & Zhang, Z. (2009). Negative sequence current distributing and single-phase open-line fault protection in distribution network. *Power System Protection and Control*, *37*(09), 35–38.
- Kang, Q., Cong, W., Wang, M., Xian, G., Liu, G., Guo, Z., & Yi, R. (2016). Analyses and judgment methods of single-phase broken-line fault for loaded distribution line. In *IEEE PES Asia-Pacific power and energy engineering conference (APPEEC)* (pp. 482–486).
- Zhang, L., Cao, L., Li, L., Xue, Y., Tian, Y., & Feng, G. (2018). Analysis and fault section location of single-phase open fault for ungrounding system. *Power System Protection and Control*, *46*(16), 1–7.
- You, Y., Liu, D., Li, L., Zheng, S., Wu, A., & Chen, H. (2012). Detection method based on load monitoring for 10 kV overhead line single-phase ungrounded open fault area. *Power System Protection and Control*, *40*(19), 114–149.
- Chang, Z., Song, G., & Wang, X. (2018). Identification and isolation of line breakage fault in distribution network based on zero sequence voltage amplitude differential principle. *Automation of Electric Power Systems*, *42*(06), 135–139.
- Peng, W., Baichao, C., Cuihua, T., Sun, B., Zhou, M., & Yuan, J. (2017). A novel neutral electromagnetic hybrid flexible grounding method in distribution networks. *IEEE Transactions on Power Delivery*, *32*(3), 1350–1358.
- Zeng, H., Yang, P., Cheng, H., Xin, J., Lin, W., Hu, W., & Wu, H. (2019). Research on single-phase to ground fault simulation based on a new type neutral point flexible grounding mode. *IEEE Access*, *7*, 82563–82570.

19. Xu, Q., He, J., Huang, S., Zeng, J., Fan, C., & Wang, W. (2019). Researches on grounding modes of the AC/DC hybrid system with various distributed renewable energy. *The Journal of Engineering*, 2019(16), 3035–3038.
20. Martínez-Molina, M. A., & Ledezma, S. N. (2016). Analysis of three-phase load flow problem in distribution networks with the inclusion of symmetric and asymmetric transformer connections. In *IEEE international engineering summit, II cumbre Internacional de las Ingenierías* (pp. 1–5).
21. Kadam, S. R., Kale, R. U., Deokar, T. V., & Pawar, P. B. (2018). Fault current & fault voltage analysis of power distribution network. In *International conference for convergence in technology* (pp. 1–4).

Submit your manuscript to a SpringerOpen[®] journal and benefit from:

- ▶ Convenient online submission
- ▶ Rigorous peer review
- ▶ Open access: articles freely available online
- ▶ High visibility within the field
- ▶ Retaining the copyright to your article

Submit your next manuscript at ▶ [springeropen.com](https://www.springeropen.com)
