

**Rethinking Ribbed Stones:
Defining a Northwest Coast Artifact Class**

**by
Walter Homewood**

B.A., Simon Fraser University, 2014

Thesis Submitted in Partial Fulfillment of the
Requirements for the Degree of
Master of Arts

in the
Department of Archaeology
Faculty of Environment

© Walter Homewood 2021
SIMON FRASER UNIVERSITY
Spring 2021

Copyright in this work rests with the author. Please ensure that any reproduction or re-use is done in accordance with the relevant national copyright legislation.

Declaration of Committee

Name: Walter Homewood

Degree: Master of Arts

Title: Rethinking Ribbed Stones: Defining a Northwest Coast Artifact Class

Committee: **Chair:** Ross Jamieson
Associate Professor, Archaeology

George Nicholas
Supervisor
Professor, Archaeology

Rick Budhwa
Committee Member
Applied Anthropologist
Crossroads Cultural Resource Management (CRM)

Dennis Sandgathe
Examiner
Senior Lecturer, Archaeology

Ethics Statement

The author, whose name appears on the title page of this work, has obtained, for the research described in this work, either:

- a. human research ethics approval from the Simon Fraser University Office of Research Ethics

or

- b. advance approval of the animal care protocol from the University Animal Care Committee of Simon Fraser University

or has conducted the research

- c. as a co-investigator, collaborator, or research assistant in a research project approved in advance.

A copy of the approval letter has been filed with the Theses Office of the University Library at the time of submission of this thesis or project.

The original application for approval and letter of approval are filed with the relevant offices. Inquiries may be directed to those authorities.

Simon Fraser University Library
Burnaby, British Columbia, Canada

Update Spring 2016

Abstract

Ribbed stones are ground stone artifacts found primarily at archaeological sites in Prince Rupert Harbour and canyons along the Skeena and Bulkley Rivers. All have deeply incised grooves that extend across at least one face of the artifact, creating a characteristic ribbed pattern of raised bands. This thesis presents an artifact class definition and morphological classification system for ribbed stones, based on the analysis of 31 specimens. Used to describe and interpret the artifact class, the system is based on physical attributes related to form. This approach, while useful, was unable to directly incorporate contextual insights shared by two Gitksan and Wet'suwet'en community members. In response to this limitation, a second classification system, referred to as "circles of belonging," was developed as a complementary method of artifact classification that may more easily engage with community derived insights and information.

Keywords: Ribbed Stones; Northwest Coast Archaeology; Artifact Classification

Dedication

To George MacDonald and Kenneth Ames for their original work on ribbed stones.

Acknowledgements

My research was conducted with the assistance of many people. The artifacts used in my research came from archaeological in the territories Gitga'at First Nation, Gitxaala Nation, Kitsumkalum First Nation, Lax Kw'alaams Band, Metlakatla First Nation, Kitselas First Nation, Gitxsan, and Wet'suwet'en. I spent the summer of 2019 conducting my research in Gitxsan and Wet'suwet'en territory and I am very thankful for the time that Jesse Stoeppler and Willie Pete took to speak with me about ribbed stones, while I was there, at two sites where ribbed stones have been found.

I was fortunate to be given time to speak with several individuals from the archaeological community: George MacDonald, Roy Carlson, Morley Eldridge, Grant Keddie, Susan Marsden, and Andrew Martindale all provided insight and advice that has been incorporated into this thesis. The information they provided enhanced my understanding of these artifacts.

I could not have completed my research without access to artifacts from the Canadian Museum of History, the Royal BC Museum, the Museum of Northern BC, and UBC's Museum of Anthropology. Access to these collections was facilitated by Stacey Girling-Christie, Grant Keddie, Genevieve Hill, Sebastian Blackthorne, Susan Marsden, Nancy Bruegeman, and Cait Pilon thank you for your guidance in navigating the repositories.

Throughout my education I continued to work as a consulting archaeologist. I am very grateful to Catherine Carlson, Sean P. Connaughton, Ian Sellers, Karen Rose Thomas, Ailidh Hathway, and Tiana Dennis at Inlailwatash who provided to the support I needed to be both a student and professional in archaeology.

Funding for my research was provided in part through the Roy L. Carlson Graduate Scholarship in Prehistoric British Columbia Archaeology. I very grateful to Roy Carlson and his generosity in establishing this scholarship.

Finally, thank you to my supervisor George Nicholas and committee member Rick Budhwa. Their instruction was essential for completing this thesis.

Table of Contents

Declaration of Committee	ii
Ethics Statement	iii
Abstract	iv
Dedication	v
Acknowledgements	vi
Table of Contents	vii
List of Tables	x
List of Figures	xi
List of Acronyms	xiv
Chapter 1. Introduction	1
1.1. Research Design	3
1.2. Terminology	4
1.2.1. Classification vs. Typology	4
1.2.2. Terminology for the Artifact Class	5
1.3. Ribbed Stones Sample	6
1.3.1. Provenience	7
1.4. Thesis Organization	10
Chapter 2. Background	12
2.1. A History of the Archaeology of Ribbed Stones	12
2.1.1. Frederica de Laguna in Alaska	12
2.1.2. Hilary Stewart's Illustrations	13
2.1.3. Louis Allaire's Excavations at Kitselas Canyon	14
2.1.4. George MacDonald and the North Coast Prehistory Project	15
2.1.5. Gary Coupland's Excavations at Kitselas Canyon	16
2.1.6. Millennia Research in Prince Rupert Harbour	17
2.1.7. Crossroads CRM at Hagwilget Canyon and Moricetown Canyon	18
2.2. Chapter Summary	19
Chapter 3. Methods	20
3.1. Literature Review	20
3.2. Developing a Form-Based Classification System	21
3.2.1. The Principles of Form-Based Classification	22
3.2.2. Benefits of Classification by Form	23
3.3. Discussions with Knowledgeable Individuals	24
3.4. Recording Attributes	25
3.5. Chapter Summary	26
Chapter 4. Results	28
4.1. Ribbed Stone Attributes	28
4.2. Classification and Typology	30
4.2.1. Class Definition	30

4.2.2.	The Ribbed Stone Classification System	31
4.2.3.	Typology.....	32
	Descriptive Types	44
4.3.	Spatial and Temporal Distribution.....	52
4.3.1.	Spatial Distribution.....	53
	Prince Rupert Harbour	54
	Kitselas Canyon	56
	Hagwilget Canyon	57
	Moricetown Canyon	58
4.3.2.	Temporal Distribution.....	59
4.4.	Chapter Summary	60
Chapter 5. Discussion.....		62
5.1.	Purpose of the Classification System.....	62
5.2.	Utility of the Classification System	63
5.2.1.	Shape.....	64
5.2.2.	Groove Location	66
5.2.3.	Groove Direction.....	68
5.2.4.	Groove Width.....	69
5.2.5.	Decoration	71
5.2.6.	Descriptive Types	73
5.3.	Limitations of Classification by Form.....	75
5.4.	Classification by Circles of Belonging	75
5.4.1.	Interpreting Ribbed Stones by Circles of Belonging	78
5.4.2.	Limitations of Circles of Belonging	82
5.5.	Chapter Summary	83
Chapter 6. The Function Question		85
6.1.	Interpreting Ribbed Stone Function	85
6.1.1.	Information from Knowledgeable Individuals.....	85
	Gitxsan and Wet'suwet'en Insights.....	86
	Archaeological Insights	88
6.1.2.	Artifact Form.....	92
6.1.3.	Repository Catalogs	93
6.1.4.	Boas' Ethnography	93
6.2.	Recommendations for Future Work on Function.....	94
6.2.1.	Use as Fibre Combs.....	95
6.2.2.	Use as a Measuring Device	95
6.3.	Chapter Summary	96
Chapter 7. Conclusions		98
7.1.	Use of the Ribbed Stone Classification System	100
7.2.	Use of Circles of Belonging	101
7.3.	Final Remarks	102

References.....	103
Appendix A. Artifact Reference Catalogue.....	109
Appendix B. Excluded Artifacts	123
Appendix C. A Guide to Ribbed Stone Typology.....	127
Step 1: Determining Artifact Class.....	127
Step 2: Determining Shape	128
Tabular	129
Elliptical Cylinder	130
Circular Cylinder	131
Amorphous	132
Step 3: Determining Groove Location.....	133
1-sided.....	133
2-sided.....	133
4-sided.....	135
Girdled.....	135
Step 4: Determining Groove Direction	136
Perpendicular	136
Parallel	137
Bidirectional.....	137
Step 5: Determining Groove Width	138
Single-width	138
Multi-width	139
Step 6: Determining Decoration	139
Undecorated	140
Geometric.....	140
Zoomorphic.....	141
Step 7: Determining the Descriptive Type	142

List of Tables

Table 1.	Interpretations of ribbed stone function.	2
Table 2.	Terms used to describe the artifact class.	5
Table 3.	Artifact provenience.	7
Table 4.	Cultural levels and dates associated with ribbed stones at Gitau (GdTc-2), from Allaire (1978:314).....	14
Table 5.	Comparison of Coupland's and MacDonald's suggested ribbed stone development.	17
Table 6.	Conceptual outline of a ribbed stone classification system.	22
Table 7.	Attributes of ribbed stones.....	29
Table 8.	Ribbed stone class definition.....	30
Table 9.	Ribbed stone classification system.....	32
Table 10.	Results of the classification system.	34
Table 11.	Ribbed stone types: shape.....	36
Table 12.	Ribbed stone types: groove location.....	38
Table 13.	Ribbed stone types: groove direction.	41
Table 14.	Ribbed stone types: groove widths.....	42
Table 15.	Ribbed stone types: decoration.....	43
Table 16.	Ribbed stone descriptive types.....	45
Table 17.	Provenience and number of ribbed stones in British Columbia.....	53
Table 18.	Date ranges for ribbed stones from excavated contexts.	60
Table 19.	Date ranges of ribbed stones by shape.	66
Table 20.	Date ranges of ribbed stones by groove location.....	67
Table 21.	Date ranges of ribbed stones by groove direction.....	69
Table 22.	Date ranges of ribbed stones by groove width.....	70
Table 23.	Date ranges of ribbed stones by decoration.	73
Table 24.	Date ranges of ribbed stones by descriptive types.	74

List of Figures

Figure 1.	An example of a ribbed stone from Hagwilget Canyon (Walter Homewood illustration).....	1
Figure 2.	A so-called whetstone with notched edge from Alaska. (Walter Homewood illustration, adapted from a photo in de Laguna 1967 [1956]:126).....	13
Figure 3.	Generalized representation of the method used to record artifact dimensions: A) 2D planar view; B) 3D perspective view (Walter Homewood illustration).....	26
Figure 4.	Elliptical cylinder shape example, ID 29: A) top profile; B) end profile (Walter Homewood photo).	36
Figure 5.	Tabular shape example, ID 1: A) top profile; B) end profile (Walter Homewood photo).....	37
Figure 6.	Amorphous shape example, ID 3: A) top profile; B) side profile (Walter Homewood photo).....	37
Figure 7.	Circular cylinder shape example, ID 35: A) top profile; B) end profile (Andrew Eckert photo, copyright Millennia Research Limited, used with permission).	38
Figure 8.	1-sided example ID 32: A) top profile; B) bottom profile (Walter Homewood photo).....	39
Figure 9.	2-sided example, ID 2: A) top profile; B) bottom profile (Walter Homewood photo).....	39
Figure 10.	4-sided example, ID 17 (photo is of a cast): A) top profile; B) bottom profile (Walter Homewood photo, courtesy of the Canadian Museum of History).	40
Figure 11.	Girdled example, ID 22: A) top profile; B) bottom profile (Walter Homewood photo).....	40
Figure 12.	Perpendicular grooves example, ID 7: top profile (Walter Homewood photo, courtesy of the Canadian Museum of History).	41
Figure 13.	Bidirectional grooves example, ID 30: top profile (Walter Homewood photo).....	41
Figure 14.	Single-width example, ID 5: top profile (Walter Homewood photo).	42
Figure 15.	Multi-width example, ID 18: top profile (Walter Homewood photo, courtesy of the Canadian Museum of History).	42
Figure 16.	Undecorated example, ID 27: A) top profile; B) bottom profile; C) end profile. (Walter Homewood photo).....	43
Figure 17.	Geometric decoration example, ID 1: A) top profile; B) bottom profile; C) end profile (Walter Homewood photo).	44
Figure 18.	Zoomorphic decoration example, ID 11 (photo is of a cast): A) top profile, B) bottom profile; C) front profile; D) back profile. (Walter Homewood photo, courtesy of the Canadian Museum of History).	44
Figure 19.	Type A example, ID 3: A) top profile; B) bottom profile; C) front profile; D) back profile (Walter Homewood photo).	46

Figure 20.	Type B example, ID 19: A) top profile; B) bottom profile; C) end profile (Walter Homewood photo, courtesy of the Canadian Museum of History).	46
Figure 21.	Type C example, ID 27: A) top profile; B) bottom profile; C) end profile (Walter Homewood photo).	47
Figure 22.	Type D example, ID 24: top profile sketch of artifact on display (Candiain Musuem of History 2020a), (Illustration by Walter Homewood).	47
Figure 23.	Type E example, ID 5: A) top profile; B) end profile; C) bottom profile. (Walter Homewood photo)	48
Figure 24.	Type F example, ID 10: A) top profile; B) bottom profile; C) front profile; D) back profile (Walter Homewood photo, courtesy of the Canadain Museum of History).	48
Figure 25.	Type G example, ID 35: A) top profile; B) end profile. (Andrew Eckert photo, copyright Millennia Research Limited, used with permission)	49
Figure 26.	Type H example, ID 31: A) top profile; B) bottom profile. (Walter Homewood photo)	49
Figure 27.	Type I example, ID 11 (photo is of a cast): A) top profile, B) bottom profile; C) front profile; D) back profile (Walter Homewood photo, courtesy of the Canadian Museum of History).	50
Figure 28.	Type J example, ID 23: Top profile sketch of artifact on display (Candiain Musuem of History 2020a), (Walter Homewood illustration).	50
Figure 29.	Type K example, ID 2: A) top profile; B) bottom profile (Walter Homewood photo)	51
Figure 30.	Type L example, ID 1: A) top profile; B) bottom profile; C) end profile (Walter Homewood photo).	51
Figure 31.	Type M example, ID 18: A) top profile; B) bottom profile; C) end profile (Walter Homewood photo, courtesy of the Canadian Museum of History).	52
Figure 32.	Type N example, ID 17 (photograph is of a cast): A) top profile; B) bottom profile (Walter Homewood photo, courtesy of the Canadian Museum of History).	52
Figure 33.	Spatial distribution of ribbed stones.	54
Figure 34.	Prince Rupert Harbour. (Walter Homewood photo)	55
Figure 35.	The Boardwalk site (GbTo-31), looking was across Digby Cove. (Walter Homewood photo)	55
Figure 36.	“Area D” trenches at the Boardwalk site (GbTo-31) (Ames 2005:67) excavated during the North Coast Prehistory Project. (Walter Homewood photo)	56
Figure 37.	Dodge Island and archaeological site GbTo-18. (Walter Homewood photo)	56
Figure 38.	Kitselas Canyon, looking down river from east of the Paul Mason site. The Gitaus site is beyond the bend in the river. (Walter Homewood photo)	57

Figure 39.	Hagwilget Canyon, photo taken from the east side of the Bulkley River, below the terrace where ribbed stones (ID 5, 6) were collected (Walter Homewood photo).....	58
Figure 40.	Moricetown Canyon from the terrace on the west side of the river (GgSt-5) where ribbed stones (ID 3; 4) were collected. View is towards the terrace on the east side of the river where ribbed stones (ID 1; 2) were collected. (Walter Homewood photo).....	59
Figure 41.	Spatial distribution of ribbed stones by shape.	65
Figure 42.	Spatial distribution of ribbed stones by groove location.	67
Figure 43.	Spatial distribution of ribbed stones by groove direction.	68
Figure 44.	Spatial distribution of ribbed stones by groove width.	70
Figure 45.	Spatial distribution of ribbed stones by decoration.....	72
Figure 46.	Spatial distribution of ribbed stones by descriptive types.....	74
Figure 47.	Circles of belonging.....	76
Figure 48.	The overlapping nature of circles of belonging.	76
Figure 49.	The classification of a ribbed stone (ID 3) by circles of belonging.....	80
Figure 50.	Visualizing shared and nested attributes with circles of belonging.....	81
Figure 51.	Colour coded circles showing shared attributes of two ribbed stones.	82
Figure 52.	ID 22 represented in the absence of contextual information.	83
Figure 53.	A replica basket trap from Widzin Kwah Canyon House Museum at Moricetown: A) basket trap replica; B) close-up view of the cedar bark lashing at the mouth of the basket trap. (Walter Homewood photo).....	87

List of Acronyms

CRM	Cultural Resource Management
PARL	Provincial Archaeological Report Library
SFU	Simon Fraser University

Chapter 1. Introduction

Ribbed stones (Figure 1) are an artifact class that has been found in archaeological sites on the north and central Northwest Coast of British Columbia and inland along the Skeena and Bulkley Rivers. They are generally characterized by a series of deeply incised grooves that extend across the entirety of at least one face of the artifact, creating a pattern of raised bands. They have been known by such terms as “segmented stones,” “segmented tablets,” “notched stones,” and “ribbed stones” – the term used in this study.

These artifacts are poorly understood in terms of their spatial and the temporal distribution, and their function. Descriptions of this artifact type are limited to a relatively small number of sources (Allaire 1978; Coupland 1988; MacDonald 1983; Stewart 1973). They have even been described as “mystery artifacts” geographically limited to Prince Rupert Harbour and the Skeena River (MacDonald 1983:114; Stewart 1873:95).

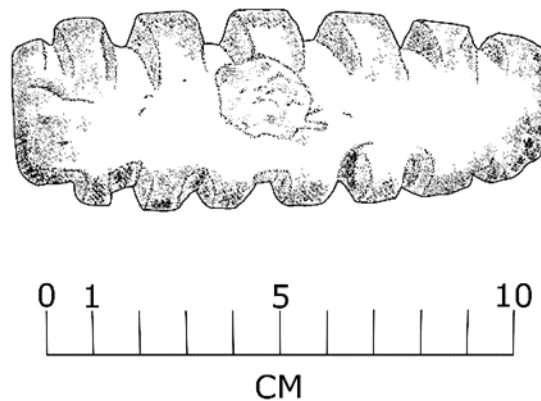

Figure 1. An example of a ribbed stone from Hagwilget Canyon (Walter Homewood illustration).

The central research question of this thesis is, what are ribbed stones and what are the attributes of their form? Two goals needed to be achieved to answer this question are: 1) compile the disparate information about ribbed stones; and 2) create a classification system for these artifacts that researchers can employ in subsequent analyses.

The ribbed stones in this study were collected over many years at the ancestral sites of the Gitga’at First Nation, Gitxaala Nation, Kitsumkalum First Nation, Lax

Kw'alaams Band, Metlakatla First Nation, Kitselas First Nation, Gitksan, and Wet'suwet'en. My research involved no excavation, but utilized data that had been collected during various excavations and field surveys, both academic and cultural resource management (CRM) based. While a lab-and-library based approach may have sufficed entirely for a project such as this, following the work of Budhwa and McCreary (2013), who emphasized the importance of researchers connecting with both people and place, I conducted field visits to sites in Prince Rupert Harbour, Kitselas, Hagwilget, and Moricetown where ribbed stones had been found. This approach enabled me to meet with two Gitksan and Wet'suwet'en community members, as well as to develop first-hand awareness of the landscape.

On the basis of my investigations, I developed a classification system to describe and interpret the artifact class. This system is based on physical attributes relating to the form of the artifact. However, I found this approach unable to incorporate insights that were shared with me by Gitksan and Wet'suwet'en community members, as they were largely contextual, regarding the archaeological sites more so than the form of the artifacts. In response to this limitation I developed an alternative classification system based on a concept I describe as "circles of belonging."

The function of ribbed stones is not known. Determining function was not a goal of my research because doing so would expand the scope of the project beyond that of a Master's thesis. Although this study was not explicitly oriented to determining their function, I did I compile information and insights into this. Five hypotheses have been proposed (Table 1): ribbed stones as art, as ceremonial objects; as fibre combs (for cedar bark or bow strings); as bark beaters; and as measuring devices (net gauges and basketry gauges).

Table 1. Interpretations of ribbed stone function.

Interpretation	Source
Art (stone sculpture)	MacDonald 1983
Ceremonial items	Canadian Museum of History 2020a; MacDonald 1983
Fibre combs (cedar bark or bow string scrapers)	Budhwa and Hosgood 2016
Bark beaters	Ames 2005; Canadian Museum of History 2020b
Measuring devices (net gauges or basketry gauges)	Canadian Museum of History 2020c; Susan Marsden, pers. comm. 2019; Willie Pete, pers. comm. 2019

Some interpretations (e.g., their use as fibre combs) have been put forward by members of the descendant communities who continue to live at the locations where ribbed stones have been found (Budhwa and Hosgood 2016), while others have been proposed by archaeologists (e.g., Ames 2005; MacDonald 1983). Other information was communicated informally to me (e.g., Susan Marsden, pers. comms. 2019; Willie Pete, pers. comm. 2019).

1.1. Research Design

This study was designed to collect all available information on ribbed stones and then to develop a classification system to define and describe the artifact class and that researchers can employ in subsequent analyses. The first goal was achieved through a literature review and discussion with knowledge holders who have insights about these artifacts, not published in the literature. This work is described in Chapter 6.

The classification system I developed was based on principles outlined by Andrefsky (2005) and by Addams and Addams (1991). I took a lab-based approach using morphological data from artifacts collected by other researchers in excavations and surveys. I also conducted field visits to archaeological sites where ribbed stones have been collected. Field visits provided additional information for me to consider when evaluating the benefits and limitations of classification based on form.

The theoretical framework for my research is largely based on the culture history approach. Artifact types reflect cultural norms, with differences in material culture used to infer differences between groups of people and individuals (Johnson 2010:18-19; Krieger 1944; Trigger 2006:303-310).

While providing a framework for the majority of my research, culture history was not the only body of theory I utilized. When considering the limitations of a morphological classification system I developed a second classification system, termed circles of belonging, utilizing theory from Indigenous research design (e.g., Smith 1999; Wilson 2008), feminist approaches to archaeology (e.g., Spector 1993), and materiality (e.g., Lazzari 2005).

Finally, the classificatory approach of this study should be considered only as a starting point for further exploring the ribbed stone artifact class. My work is primarily

intended for use by archaeologists working with ribbed stones. However, the lessons I learned about artifact classification, particularly as it applies to Northwest Coast archaeology, and my development of the circles of belonging classification system, is intended to be a broader contribution, with principles that can be applied to a wide range of Northwest Coast artifacts.

1.2. Terminology

In this section I define key terms used throughout this thesis. I first explain my use of “classification” and “typology” as well as “artifact class” and “artifact type.” I then describe the process by which the term “ribbed stone” was chosen to represent the artifact class investigated.

1.2.1. Classification vs. Typology

“Classification” refers to the process by which objects are grouped and “typology” to refer to the groups that result from classification. An *artifact class* is the largest category and includes all artifacts that are described in this thesis as “ribbed stones,” whereas *artifact type* refers to groups of ribbed stones that share the same descriptors used in the classification system. In other words, “ribbed stone” is the artifact class, and the class is divided into the ribbed stone types.

The terms “classification” and “typology” are sometimes used interchangeably and there are discrepancies in the use of the term between or even within publications. Addams (2008:1019) states that,

Properly speaking, however, a typology is just one particular kind of classification: an ordering of physical or tangible entities into discrete and mutually exclusive groups. The entities most commonly included in a typology are artifacts – above all pottery and lithic remains – but there are also typologies of houses, graves, and other cultural manifestations. Classification is a more inclusive term that includes typologies, but also includes the chronological or spatial ordering of cultural data: the recognition and naming of different culture complexes in different area, and also the division of culture sequences into successive phases.

However, in the glossary of the same chapter, Addams (2008:1019) provides the following definitions for classification and typology,

- Classification: Grouping of ideas and objects into categories with specific purpose;
- Typology: Classification of things according to their characteristics.

In an earlier publication, Addams and Addams (1991:333; 370) provide more lengthy definitions for the two terms:

- Classification: a matched set of contrasting categories which, collectively, include all of the entities or phenomena within a particular field of study, or set of boundaries.
- Typology: a particular kind of classification, one made specifically for the sorting of entities into mutually exclusive categories which we call types.

In general, the definitions suggest that classification involves grouping objects and typology is a form of classification that relates to organizing those groups into types.

1.2.2. Terminology for the Artifact Class

A variety of terms have been associated with these intriguing artifacts (Table 2). I chose to use “ribbed stone” in this study for two reasons: 1) it best describes the defining characteristic of the artifact class (i.e., a ribbed pattern of raised bands); and 2) it has been the most frequently used descriptor across multiple publications.

Table 2. Terms used to describe the artifact class.

Term	Source
ribbed stones	Ames 2005; Coupland 1988; MacDonald 1983; MacDonald and Inglis 1981; Stewart 1973
segmented stones	Ames 2005; Budhwa and Hosgood 2016; MacDonald 1983; Millennia Research 2013, 2014
segmented tablets	MacDonald and Inglis 1981
notched stones	Allaire 1979; de Laguna 1934, 1967 [1956]
Les ornemants à entailles [“notched ornaments”]	Allaire 1978

When deciding which term to use for my thesis, I only considered the four English descriptors in use: “ribbed stones,” “segmented stones,” “segmented tablets,” “incised tablets,” and “notched stones.” Allaire’s “Les ornemants à entailles” was a descriptor used specifically for a French language thesis (1978). Of the four terms, I found “tablet” (as in “segmented tablets) unsuitable, as it invokes a specific shape (i.e., tabular) but the artifact class contains multiple shapes.

The three remaining descriptors—notched stones, segmented stones, and ribbed stones—all refer to a pattern of grooves and bands. In considering which descriptor to use, I first considered the common definitions of the terms:

- “notched”: marked with a notch or notches; notch defined as to have made an indentation or incision on an edge or surface;
- “segmented”: consisting of or divided into segments; and
- “ribbed”: having a pattern of raised bands (Oxford University Press 2019).

Based on these definitions, “segmented” was inappropriate as it suggests that the divisions are an intended feature and may be associated with a specific function—unless simply decorative. I also excluded “notched” because it did not reflect that, in some cases, the grooves girdled the artifact. That term was also problematic because de Laguna (1967[1956]:126-128) used “notched whetstones,” so “notched” would potentially conflate what I saw as two separate artifact classes. This left “ribbed” as the most accurate and applicable term since it describes the pattern of raised bands present on the artifacts.

“Ribbed stone” is also the most consistently used term for the artifact class appearing in five publications (Ames 2005; Coupland 1988; MacDonald 1983; MacDonald and Inglis 1981; Stewart 1973). Additionally, this is the only term used by author/illustrator Hilary Stewart in *Artifacts of the Northwest Coast Indians* (1973, 1996). Her illustrations of five ribbed stones demonstrate the variability of these artifacts making, it useful reference material for archaeologists who might recover ribbed stones in excavations, but are unfamiliar with the artifact class. Using the same descriptor as Stewart ensures archaeologists using her reference materials will be able to locate my thesis through a key word search for “ribbed stones”.

1.3. Ribbed Stones Sample

This section describes the location of the 31 ribbed stones evaluated in this study. Ribbed stones were identified first through a literature review and then later through physically searching repository collections. During my data collection I also examined six artifacts that Allarie (1978,1979) included as part of the ribbed stone artifact class, but which I do not consider to be ribbed stones.

The six excluded artifacts all exhibit forms that I consider to be outside of the variation of ribbed stones. Most notably, they lack the characteristic pattern of deeply incised grooves that extend across the entirety of at least one face of the artifact. They are described in detail in Appendix B along with a rationale for their exclusion.

I initially identified 28 examples of ribbed stones during my literature review. Artifact provenience was traced through publications and archaeological site records, and listed repositories were then contacted to relocate the artifacts. Four repositories were contacted and confirmed ribbed stones in their collections: the UBC Museum of Anthropology, the Royal BC Museum, the Museum of Northern BC, and the Canadian Museum of History. During my visits for data collection three additional ribbed stones were found by myself and curators by physically searching museum storage. In total 31 ribbed stones were located.

1.3.1. Provenience

The provenience of each ribbed stone is provided in Table 3, all come from British Columbia. I assigned a unique identification number to each of the ribbed stones. The ID numbers are non-sequential because some artifacts initially given ID numbers for photographs and measurements were subsequently removed from the ribbed stone artifact class. Entries were listed as “N/A” when provenience data such as site or catalogue numbers were unavailable.

Table 3. Artifact provenience.

ID	Site Location	Site No.	Current Location	Catalogue Number	Comments
1	Moricetown Canyon	N/A	*Crossroads CRM/ Bulkley Valley Museum	N/A	From terrace on east side of canyon.
2	Moricetown Canyon	N/A	Crossroads CRM/ Bulkley Valley Museum	N/A	From terrace on east side of canyon.
3	Moricetown Canyon	GgSt-5	Crossroads CRM/ Bulkley Valley Museum	N/A	From terrace on west side of canyon.
4	Moricetown Canyon	GgSt-5	Crossroads CRM/ Bulkley Valley Museum	N/A	From terrace on west side of the canyon.
5	Hagwilget Canyon	N/A	Crossroads CRM/ Bulkley Valley Museum	N/A	From highest terrace on east side of the canyon.

ID	Site Location	Site No.	Current Location	Catalogue Number	Comments
6	Hagwilget Canyon	N/A	Crossroads CRM/ Bulkley Valley Museum	N/A	From highest terrace on east side of the canyon.
7	Kitselas Canyon (Gitaus)	GdTc-2	Canadian Museum of History	GdTc:2-19	
9	Kitselas Canyon (Gitaus)	GdTc-2	Canadian Museum of History	GdTc-2:166	
10	Kitselas Canyon (Gitaus)	GdTc-2	Canadian Museum of History	GdTc-2:1198	
11	Kitselas Canyon (Gitaus)	GdTc-2	Canadian Museum of History	GdTc-2:1219	
17	Prince Rupert Harbour, Digby Island (Boardwalk Site)	GbTo-31	Canadian Museum of History	GbTo-31:2176	
18	Morictown Canyon	N/A	Canadian Museum of History	XI-A-1460	
19	Masset, Haida Gwaii	N/A	Canadian Museum of History	XII-B-706	
20	Kitselas Canyon (Gitaus)	GdTc-2	Canadian Museum of History	GdTc-2:300	
21	Prince Rupert Harbour, Digby Island (Boardwalk Site)	GbTo-31	Canadian Museum of History	GbTo-31:2053	
22	Northern Northwest Coast	N/A	UBC Laboratory of Archaeology	A7172	
23	Prince Rupert Harbour, Kaien Island (Reservoir Site)	GbTo-33	Canadian Museum of History	GbTo-33:c388	
24	Prince Rupert Harbour (outer mainland)	GcTo-31	Canadian Museum of History	GcTo-31:x717c	On the mainland, approximately 13 km northwest of Prince Rupert and 6 km north of Metlakatla.

ID	Site Location	Site No.	Current Location	Catalogue Number	Comments
25	Prince Rupert Harbour	N/A	Canadian Museum of History	-	This specimen is displayed in "The Dig" exhibit, developed by George MacDonald, along with other artifacts from Prince Rupert Harbour collected during the North Coast Prehistory Project. No additional provenience information is available.
26	Prince Rupert Harbour, Digby Island (Boardwalk Site)	GbTo-31	Canadian Museum of History	GbTo-31:X-896	
27	Prince Rupert Harbour, Digby Island (Crippen Cove)	GbTo-19	Royal BC Museum	GbTo-Y:59	
28	Prince Rupert Harbour	N/A	Royal BC Museum	GbTn-Y:8	
29	Prince Rupert Harbour (Dodge Island)	GbTo-18	Royal BC Museum	GbTo-Y:167	
30	Prince Rupert Harbour	N/A	Royal BC Museum	GbTn-Y:9	
31	Prince Rupert Harbour, Digby Island (Charles Point)	GbTo-16	Museum of Northern BC	GbTo-16:1	Intertidal surface find recorded on foreshore in front of GbTo-16 (Stantec 2018)
32	Skeena River	N/A	Museum of Northern BC	N/A	Surface find from along the Skeena River, west of Terrace (Susan Marsden, pers. comm. 2020).
35	Prince Rupert Harbour, Kaien Island	GbTo-54	Museum of Northern BC	GbTo-54:1576	
36	Prince Rupert Harbour, Kaien Island	GbTo-54	Museum of Northern BC	GbTo-54:2881	
37	Prince Rupert Harbour, Kaien Island	GbTo-54	Museum of Northern BC	GbTo-54:3094	

ID	Site Location	Site No.	Current Location	Catalogue Number	Comments
38	Húyat	N/A	N/A	N/A	Intertidal surface find, recorded, photographed and left in place (Julia Jackley, pers. comm. 2019).
39	Kitselas Canyon (Paul Mason Site)	GdTc-16	N/A	N/A	Collected by Gary Coupland from excavations at the Paul Mason site, I was unable to locate it in any repository.

*Access and laboratory space for the ribbed stones held by the Bulkley Valley Museum was facilitated by Crossroads CRM.

1.4. Thesis Organization

This thesis is organized into seven chapters. Chapter 1 introduces my central research question and approach. I provide a general description of ribbed stones, list the five interpretations of function that have been put forward, introduce my research design, and define the terminology used in this thesis. I then provide the provenience of the 31 ribbed stones that were used in this study.

Chapter 2 provides a history of the archaeology of ribbed stones. Here I detail the researchers and projects that covered the artifact class.

Chapter 3 describes the methods employed for this project, including the collection of both quantitative and qualitative data. I provide a conceptual outline and theoretical basis for the development of my ribbed stone classification system.

Chapter 4 presents the results of my research, the quantitative and qualitative data that I collected, the ribbed stone classification system, and resulting ribbed stone typology. The artifact class is defined and an example of each ribbed stone type is provided.

Chapter 5 discusses the results of the ribbed stone typology and addresses some of the shortcomings. I introduce a second classification system based on what I refer to as “circles of belonging.” This classification system is designed to incorporate historical knowledge from traditional knowledge holders directly into the process of

classification, rather than as supplemental information used to interpret the results of morphological classification.

Chapter 6 expands on the interpretations of function. This chapter compiles all of the disparate information about ribbed stones, including unpublished information shared with me through informal discussions. I provide recommendations for future work on ribbed stone function.

In the final chapter, I re-engage with my central research question/goals. I recommend next steps for continued use of both my ribbed stone classification system and classification by circles of belonging. My closing remarks regard what I learned about the process of artifact classification in general.

Chapter 2. Background

This chapter provides background information regarding what is known about ribbed stones. Two major topics are addressed here: 1) the history of archaeological research on ribbed stones; and 2) the descriptions of these objects in the archaeological literature.

2.1. A History of the Archaeology of Ribbed Stones

When I began this research there had been no comprehensive study of ribbed stones. What information was available was scattered across a variety of sources that included journal articles, published reports, unpublished CRM reports, and online blogs. The history outlined here is grouped by project and ordered roughly chronologically based on dates of publication, not necessarily the order of fieldwork. Below I review, in sequence, the work of Frederica de Laguna, Hilary Stewart, Louis Allaire, George MacDonald and the North Coast Prehistory Project, Gary Coupland, Millennia Research, and Crossroads CRM.

2.1.1. Frederica de Laguna in Alaska

In 1934, Frederica de Laguna published results from her excavations in Cook Inlet, Alaska. She referenced a class of artifacts she referred to as “notched stones” (de Laguna 1934:122), a term that would become synonymous with ribbed stones. In *Chugach Prehistory: The Archaeology of Prince William Sound, Alaska* (de Laguna 1967 [1956]:126-128), she applied that term to similarly shaped artifacts, which were described as “grooved whetstones” or a “whetstone with notched edge” (Figure 2), “presumably used for shaping and sharpening small stone and bone objects” (p. 124). “Notched stone” would later be applied to a variety of artifacts by Allaire (1978), conflating de Laguna’s artifact class of “whetstone with notched edge,” and the separate artifact class of ribbed stones.

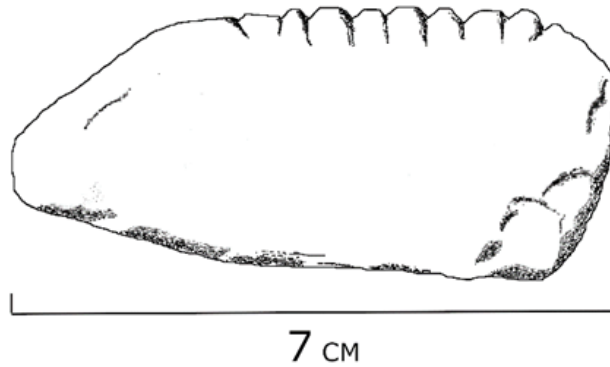

Figure 2. A so-called whetstone with notched edge from Alaska. (Walter Homewood illustration, adapted from a photo in de Laguna 1967 [1956]:126).

2.1.2. Hilary Stewart's Illustrations

Hilary Stewart, an author and artist, illustrated five examples of ribbed stones for her publication *Artifacts of the Northwest Coast Indians* (1973), but with little provenience information. She indicated that two are from Prince Rupert Harbour, one is from Kitselas Canyon, one is from the Northern Northwest Coast, and one is from the Northwest Coast. In describing ribbed stones she noted that,

Another archaeological puzzle of the Northwest Coast is the ribbed stone in all its variations. It is even difficult to speculate what the purpose of these stones could have been as there is no wear pattern, yet the stone is usually sandstone or some other soft material. Large numbers of these have been unearthed, all within the area of the Tsimshian (Stewart 1973:95).

Stewart organized her illustrations of artifacts based on material type and groups artifacts of a similar function (e.g., hand mauls are followed by grooved mauls, which are followed by cylindrical mauls). In Stewart's original 1973 publication, ribbed stones were presented alongside "biconical stones" (p. 95), with other ground stone artifacts, pestles and mortars following on subsequent pages (p. 96-97). Notably, in the 1996 reprinting of the volume, retitled *Stone, Bone, Antler & Shell: Artifacts of the Northwest Coast*, ribbed stones are presented again alongside biconical stones (Stewart 1996:79) but with the following pages showing "Sculptured Stones" (p. 80) and "Whatzits" (p. 81), suggesting that the stones are more closely related to these artifacts. The text describing ribbed stones was also updated to read:

One archaeological enigma is the ribbed stone in all its variations. There is no evidence of wear, even though they are mostly made of sandstone or other easily worked stone. It is even difficult to speculate what the purpose of these stones may have been. Perhaps they were used to keep a tally of some kind. Large numbers of these have been unearthed, some in the Prince Rupert area but the majority at Kitselas Canyon, a major fishing station on the Skeena River, so there may well be an association with salmon – ceremonial or otherwise (Stewart 1996:79).

Stewart provided no sources for her interpretation of ribbed stones in either publication, but the information likely came from MacDonald (1983). Her original description was ground stone “mystery artifact’ (1973:). This later changed to objects possibly associated with salmon and salmon ceremony in a later edition (1997:).

2.1.3. Louis Allaire’s Excavations at Kitselas Canyon

Louis Allaire collected ten artifact, which he called “les ornament à entailles [the notched ornaments],” during excavations at the Gitaus Site (GdTc-2), Kitselas Canyon, in 1968. Photographs and descriptions, plus an age range for cultural levels were published in *L’archaeologie des Kitselas d’apres les site stratifie de Gitaus (GdTc:2) sur la riviere Skeena en Colombie Birtannique* (Allaire 1978).

Allaire (1978:vii) identified five cultural levels at the site, with the earliest (Level V) dating to 2000-1700 BC and the most recent (Level I) around AD 500¹. He found three of the ribbed zones in Upper Level III, two in Level II and III, four in Level I, and one on the surface (Table 4). Level II was dated to around AD 1, with site occupation ending around AD 500 (1978:vii, 314), meaning that all of the ribbed stones found at the Gitaus site in controlled excavations, date to a 500-year period from AD 1-500.

Table 4. Cultural levels and dates associated with ribbed stones at Gitaus (GdTc-2), from Allaire (1978:314).

Ribbed Stone Count	Level	Time Period
3	Upper Level III	ca. AD 1
2	II + III	AD 1–500
4	I	ca. AD 500
1	Surface	Unknown

¹ Allaire used BC/AD dates, not years before present, in his reports.

Allaire (1978:235-236) described the ribbed stones collected at the Gitaus site as similar to artifacts collected by de Laguna in Alaska and introduced his own term for the artifact class “les ornemants à entailles [notched ornaments]” in his thesis, which was published in French. In a later publication (in English) on the excavations, he used “notched stones” and “grooved stones,” which he considered part of the “ground stone industry” (Allaire 1979:42).

2.1.4. George MacDonald and the North Coast Prehistory Project

The North Coast Prehistory Project, directed by George MacDonald, began in 1966 while he was the West Coast Archaeologist at what is now the Canadian Museum of History. Excavations were conducted between 1966 and 1972 across a total of 19 sites on the Skeena River, in Prince Rupert Harbour, and on Haida Gwaii. A total of 21,750 artifacts were collected (MacDonald and Inglis 1981:37-38, 43).

In a summary of the North Coast Prehistory Project, MacDonald and Inglis (1981:42-56) defined a sequence of three cultural historical periods at Prince Rupert Harbour: Period III = 3000 to 1500 B.C.; Period II = 1500 B.C. to AD 500; and Period I = AD 500 to 1830. Ribbed stones were listed among the artifacts recovered but described only as being rare artifacts that appear in Period I and Period II (Macdonald and Inglis 1981: Figure 11). MacDonald and Inglis (1981:47) used “ribbed stones” and “segmented tablets” synonymously and included them with other “decorated stone items.”

The most detailed discussion of ribbed stones from the North Coast Prehistory Project comes from Macdonald (1983). He considered them in the context of northern Northwest Coast art and described ribbed stones as a form of stone sculpture having descended from incised concretions² (MacDonald 1983: 114). Unfortunately, MacDonald’s line of reasoning for this transition is somewhat obtuse, as evident in this quotation from his discussion of ribbed stones:

A very elaborate incised concretion (GbTo 36-128; Fig. 6:22) dating from around the time of Christ, has the core elements such as the backbone of parallel lines continuing through the head, clearly defined ribs, eyes and mouth. In addition it has clearly defined [fore] and hind limbs and paws, and on the underside an ovoid joint mark and tail or fin element composed of

² MacDonald (1983:11-113) described incised concretions as soft sedimentary stones with zoomorphic images incised into the surface of the artifact.

crude U-shaped elements. It is truly a monster figure combining limb features of several different creatures. An undated find from Kitselas Canyon (Fig. 6:23) probably fits into the sequence about the time of Christ. It illustrates well the meaningless combination of core design elements such as backbone, mouth gash and eyes. Nevertheless, it still retains the appearance of a creature of some kind, or a monster, which is lost in the next series of segmented tabular forms.

Although the development of segmented stones begins in incised concretions and develops over a millennia, by about 500 B.C. it has achieved the level of a purely formal statement. In one example (GbTo 31:X717; Fig. 6:24), head and tail features are totally eliminated. The tabular body section is divided on both sides by a mid-line, and the rib and vertebral elements are matched except that they are interrupted on one side.

A second example (GbTo 31-2176; Fig. 6:25), lacks the mid-line and the deeply carved segments completely encircle the form. Other examples of ribbed forms from the North Coast are illustrated by Stewart (1973:95), and many others were recovered from the site of Gitaus (GdTc 1) in the Kitselas Canyon. Since this major fishing station on the Skeena River produces an inordinate number of ribbed stones their association with fish ceremonies is strongly implied (MacDonald 1983:113-114).

Based on four artifacts, one of which was an undated surface find, MacDonald proposed that incised concretions first appeared around 1500 BC and that by 500 BC had transitioned to ribbed stones. It remains unclear how this sequence was derived and how accurate his timeline is.

MacDonald concluded his discussion of ribbed stones by suggesting that they are associated with fish ceremonies (although no ceremony indicated). However, "The Dig" display at the Canadian Museum of History, which MacDonald later developed, included three ribbed stones: two are described as "ribbed stones used by shamans in first salmon ceremonies;" the third as an "amulet" (Canadian Museum of History 2020a).

2.1.5. Gary Coupland's Excavations at Kitselas Canyon

In *Prehistoric Cultural Change at Kitselas Canyon*, Gary Coupland (1988) reported on his investigations of sites within Kitselas Canyon along the Skeena River. This included a re-examination of artifacts from the Gitaus site (Allaire 1978) and artifacts from his own excavations at the Paul Mason site (GdTc-16), where one ribbed stone was recovered. Coupland included that item within his category of "ornamental/decorative objects" (Coupland 1988:165, 356, Plate VII). He noted that,

“One of the incised tablets is a ribbed stone (Plate VII k). In the Tsimshian area, ribbed stones were manufactured as early as 3500 B.P., and became common between 3000 and 2500 B.P.” (1988:165). Coupland also noted that “a segmented or ribbed stone, similar to those described by H. Stewart (1973:95) and MacDonald (1983:114), was recovered (Plate VII k). Manufactured from sandstone, it includes four straight parallel incised lines” (Coupland 1988:356). He dated the level the ribbed stone came from to between 1500 and 750 BC³ (Coupland 1988:146, 165, 242, 378)

Coupland used both “ribbed stone” and “segmented stone” in the artifact descriptions in his 1988 publication. He briefly mentions a timeline of 1500 BC being the earliest date for the manufacture of ribbed stones and ribbed stones becoming common between 1000 and 500 BC. This date range is slightly different from MacDonald’s (1983), and could possibly be due to Coupland conflating ribbed stones with MacDonald’s (1983:113) “incised concretions.” I present the two timelines below (Table 5). Coupland’s radiocarbon dates have been converted to calendar year for comparison. Perhaps due to his focus on cultural change, Coupland offered no interpretation of ribbed stones and limited his descriptions to form and date ranges.

Table 5. Comparison of Coupland’s and MacDonald’s suggested ribbed stone development.

Coupland (1988)		MacDonald (1983)	
Date	Description	Date	Description
1500 BC	Earliest date for the manufacture of ribbed stones.	1500–500 BC	Development of ribbed stones from incised concretions.
1000–500 BC	Ribbed stones become common.	500 BC	Ribbed stones reached the level of purely formal statement.

2.1.6. Millennia Research in Prince Rupert Harbour

Millennia Research described three ribbed stones and one zoomorphic concretion that had been collected in Prince Rupert Harbour from excavations carried

³ All dates presented in this thesis were converted to calendar dates for comparison. The choice to convert to calendar dates was made because that convention was most commonly employed in earlier reports (e.g., Allaire 1978 and Macdonald 1983) and because radiocarbon dates presented in calibrated years BP can be converted to calendar dates, but the reverse conversion is not easily done.

out for cultural resource management work there (Millennia Research 2013, 2014). A blog post on the company website notes that,

Segmented stones are found in middle to late period sites in the Coast Tsimshian and Tlingit territories. These enigmatic objects are carefully shaped from stone; George MacDonald considers them to be symbolic of the axial skeleton of fish and mammals, and to have developed from early versions that were more realistic and often etched on soft concretions, such as the zoomorphic concretion (Millennia Research 2013).

These artifacts were scanned to create 3D models that were incorporated into Millennia's geographic information system.

In a report produced for the Canadian National Railway (Millennia Research 2014:319-325), a more detailed discussion of ribbed stones was provided, along with artifact descriptions and photographs. It referenced similar objects reported in Allaire (1979), Ames (2005), Coupland (1988), MacDonald (1983), and MacDonald and Inglis (1981). Included was a discussion (pp. 322–325) of the suggestion that ribbed stones had developed from incised concretions, citing MacDonald (1983). The Millennia report also stated that, “there are many segmented stones from beaches in private collections from Prince Rupert and on display at Prince Rupert’s Museum of Northern BC (M. Eldridge personal observation)” (2014:324).⁴

2.1.7. Crossroads CRM at Hagwilget Canyon and Moricetown Canyon

Between 2004 and 2014, six ribbed stones were collected in excavations conducted as part of cultural resource management work along the Bulkley River (Crossroads CRM 2016a, 2016b, 2017). Four were collected at Moricetown Canyon: two from the terrace on the east side of the river; and two more from the terrace on the west side of the river. Another two were recovered from Hagwilget on the south terrace that overlooks the canyon where the river was once crossed by a wooden cantilever bridge, long since replaced by the modern Hagwilget Canyon Bridge. In both cases the excavations were conducted in disturbed contexts. The six ribbed stones collected by

⁴ I was unable to verify this as no ribbed stones were observed either by myself or Susan Marsden (Curator, Museum of Northern BC) in the museum displays.

Crossroads CRM are jointly curated by Crossroads CRM and the Bulkley Valley Museum (Rick Budhwa, pers. comm. 2019).

Following the excavations at Hagwilget, Rick Budhwa (Crossroads CRM) discussed the collected artifacts with Gitxsan and Wet'suwet'en community members. On the function of ribbed stones, *Gisdewe* [Alfred Joseph], House Chief of Këyikh Winits of the Gidimt'en clan, "explained how the ridged tools were used to smooth out strands of cedar bark used for ropes, fishing nets, and fishing baskets. The grooves acted as a comb to separate several strands at once" (Budhwa and Hosgood 2016:114).

Another interpretation for the use of ribbed stones was put forward by Wet'suwet'en elder, Peter David, during archaeological excavations at Moricetown. Peter David's interpretation was that ribbed stones were used as a measuring device used in the manufacture of gill nets. Gill nets are often used to harvest fish of a specific size, as fish smaller than the weave of the net will pass through and larger fish will not be trapped in the weaving. The selection of fish based on size is a current practice of the salmon fishery at Moricetown (Willie Pete, pers. comm. 2019).

2.2. Chapter Summary

Ribbed stones are primarily found at Prince Rupert Harbour and in the Skeena River watershed. While similar artifacts were first recovered by Frederica de Laguna, in Alaska, and her work has influenced the various descriptors used for ribbed stones, I consider the artifacts described by de Laguna to be separate from the ribbed stones examined in this thesis.

The work of George MacDonald, through the North Coast Prehistory Project, and other works funded in part by the Canadian Museum of History collected the largest number of ribbed stones and the only ribbed stones with dates attributed. Up until the early 2010s, ribbed stones were discussed in publications that were a result of academic research. More recently ribbed stones have been recovered in excavations from CRM projects.

Chapter 3. Methods

This chapter describes the methods used in gathering qualitative and quantitative data regarding ribbed stones. I first describe the qualitative methods used, which consisted of a literature review, the development of a classification system based on form, and my method for information gathering through discussions with knowledgeable individuals. The quantitative methods employed in this study relate to the recording of physical attributes (e.g., length, material type) of artifacts available for examination at repositories.

3.1. Literature Review

Four questions guided the literature review I conducted: 1) how many ribbed stones have been collected and in what repositories are they now located?; 2) what is their spatial and temporal distribution; 3) how have they been described by archaeologists?; and 4) how has function been interpreted? In general the literature review informed the background of this thesis (Chapter 2). Results of the temporal and spatial distributions of ribbed stones are presented in Chapter 4 and discussed in Chapter 5. Although determining function was not a goal of my research I compile the different interpretations I encountered in Chapter 6.

The literature review began with the four primary sources on ribbed stones—MacDonald (1983), MacDonald and Inglis (1981), Millennia Research (2013), and Morin (2016). I searched the Simon Fraser University Library catalogue, archaeological journals (e.g., *Canadian Journal of Archaeology*, *Journal of Arctic Archaeology*, *BC Studies*), Google Scholar, and the BC Provincial Archaeological Report Library. Additional sources were identified through careful search of publication and report citations, bibliographies, and library/repository catalogue listings. The catalogue search was conducted using the terms “ribbed stone,” “segmented stones,” “segmented tablets,” “incised tablets,” “notched stones,” and both “les ornemants a entailles” and its English translation, “notched ornaments.”

The Provincial Archaeological Report Library (PARL) provided access to CRM reports for projects in British Columbia conducted under Provincial archaeological permits (for archaeological impact assessments, site alterations, and academic research

projects). Notably, because permits are not required for archaeological field surveys not involving excavation or artifact collection, the PARL database search might not include surface finds. Ribbed stones have been reported in surface collections (Allaire 1978; Julia Lackley, pers. com. 2019; George MacDonald, pers. com. 2019). Similarly, PARL does not have records of ribbed stones found during surveys and excavations conducted on federally regulated lands (e.g., Indian Reserves).

3.2. Developing a Form-Based Classification System

My classification system for ribbed stones is based on Loy and Powell's *Archaeological Data Recording Guide* (1977) for artifact collections in British Columbia. Their system is organized by a sequence of "entries" that correspond to descriptions of form, beginning with general attributes shared across the entire class, followed by increasingly specific ones used differentiate between artifact types.

Before beginning any data collection, I developed a conceptual framework for the classification system based on eight "entries" describing the characteristics of ribbed stones with increasing specificity (Table 6). The first five entries: category; material; material modifier; manufacturing technique; and artifact class are used to determine what artifacts belong in the ribbed stone artifact class. The remaining entries: shape; shape modifier; and decoration are used describe the form of the artifact using standardized language and to sort the class into types, which can be used for comparison across time and space to check for regional differences or changes in form.

Table 6. Conceptual outline of a ribbed stone classification system.

Entry	Level Name	Description
1	Category	A generalized term of broad classification (e.g., “artifact” as a category separate from “feature” or “ecofact”).
2	Material	A descriptor of the material type beginning with the most general (e.g., stone as a separate class from bone or shell).
3	Material Modifier	A modifier that separates materials (e.g., stones may be separated into conglomerates, sandstones, siltstones).
4	Manufacturing Technique	The method by which the artifact was made (e.g., ground stone vs chipped stone).
5	Artifact Class	A descriptive name assigned to the artifact class (e.g., ribbed stone).
6	Shape	Details relating to the general shape and profile of the artifact (e.g., tabular or amorphous).
7	Shape Modifier	A modifier used to describe the individual characteristics of the artifact (e.g., location of ribs and grooves).
8	Decoration	A modifier used to describe the presence, absence, and form of decorations or adornments (e.g., geometric, zoomorphic).

3.2.1. The Principles of Form-Based Classification

The classification of artifacts by form is a fundamental element in archaeology. Methods of classification were developed during the cultural historical period of archaeological theory, beginning in the late nineteenth century (Trigger 2006:211). These methods can be generally described as organizing artifacts first by material and then by form (Gorodzov 1933), with form further split by a hierarchical approach that describes the artifact’s shared attributes and then progresses to specific attributes (Colton and Hargrave 1937).

The classification system that I created is an “artificial classification” system that results in “artificial types invented by the classifier for [their] own purposes” (Adams and Adams 1991:331). I chose not to use the method of attempting to recognize emic types (Rouse 1939), nor to seek discovering “natural” types as my classification system does not rely on types defined by statistical groupings (Spaulding 1953). It has been argued that all classification systems result in types that are at least partly natural and partly artificial (Adams 2008:1026; Addams and Adams 1991:67-68; Willey and Phillips 1958:13), however I view my classification system as wholly artificial.

In relation to Andrefsky’s (2005:67-73) description of typologies, my classification system for ribbed stones is a polythetic, divisive, disassociated approach. The system is

polythetic in that “no single attribute is the most important at any one time” (Andrefsky 2005:67). Entries in my ribbed stone classification system are numbered for organization purposes only and do not represent a hierarchy of importance.

My ribbed stone classification system is divisive in that the system “begins by recognizing the entire population as a single group and gradually divides the population into progressively smaller groups” (Andrefsky 2005:68). I based the classification system on the notion that all of the artifacts share common characteristics and belong to the “ribbed stone” artifact class. The artifact class is then divided into smaller groups that can be lumped or split into “types” by combining the entries of the classification system.

In terms of an associated and disassociated approach (Andrefsky 2005:72-73), I utilized a disassociated approach. In an associated approach, “types [are] defined as a result of significant association of attributes,” and “classification schemes based upon association typically use a test of statistical significance to determine types” (Andrefsky 2005:72). An associated approach prioritizes similarities within types, the disassociated approach prioritizes differences between groups (Hodson 1982). I chose a disassociated approach because I wanted a system that could be flexible to the needs of future researchers. The entries of the ribbed stone classification system are not associated and can be lumped or split in different combinations. This design allows different attributes to be examined together or in isolation.

3.2.2. Benefits of Classification by Form

My classification of ribbed stones by form is an example of a “phenetic (morphological) typology” (Addams and Addams 1991:217). Use of the system falls into the category of a “basic typology.” Its purpose is “to express or learn something about the material being classified” (Addams and Addams 1991:215). Such classification has three purposes: 1) to describe the material from one site; 2) to compare the materials from different sites; and 3) to learn about the nature and variability of the material being classified (Addams and Addams 1991:216). The primary benefit of a morphological classification system is that it provides standardized language for recording the physical description of the artifact and a means for comparing artifacts between sites (Adams and Adams 1991:318; Andrefsky 2005:85).

Once artifacts are described and compared, the archaeologist can then begin to ask questions about the artifacts, such as: how different are these groups of artifacts?; are there changes within or between the groups over time?; and are there differences in the groups by location? These are fundamental questions in archaeology and the ability to answer them through a classification system based on form is one of the reasons this practice has persisted for so long (Trigger 2006:235-241). I designed my classification system so that it can be used to address the questions listed above.

3.3. Discussions with Knowledgeable Individuals

To obtain additional information and insights on ribbed stones, I sought out individuals who had some familiarity with ribbed stones or the locations where they have been collected. I met with two Gitxsan and Wet'suwet'en community members and six archaeologists⁵. Gitxsan and Wet'suwet'en community members were referred to me by Rick Budhwa. This approach was opportunistic in that it resulted in my contact being with community members that were available and introduced to me during my time in Gitxsan and Wet'suwet'en territory. Archaeologists were referred to me by George Nicholas as individuals who had familiarity with the archaeology of Prince Rupert Harbour and the Skeena River

Discussions with the individuals contacted were informal. Those conducted in person or by phone were conversational in nature. For those communications done through e-mail, I attempted to follow an informal style. The purpose of these discussions was to collect information and ideas regarding ribbed stones that may not have been published. In my conversations and other exchanges, I sought information on three aspects of ribbed stones that I was interested in:

- 1) What are the possible uses for ribbed stones?
- 2) What is the importance of the ribbed pattern (i.e., the incised parallel lines)?
- 3) What is the context and importance of the locations where ribbed stones were found?

⁵ "Community member" and "archaeologist" are not mutually exclusive categories.

Interviews conducted for research purposes required a university ethics review. My research project application (Study Number: 219s0172) was approved on May 24, 2019, as Minimal Risk by an authorized delegated reviewer for the SFU Research Ethics Board. All discussions that I had with knowledge holders were conducted in accordance with the guidelines set out by the Tri-Council Policy Statement: Ethical Conduct for Research Involving Humans Course on Research Ethics (TCPS 2:CORE), including Module 9: Research Involving First Nations, Inuit & Métis Peoples of Canada.

3.4. Recording Attributes

Four attributes were used to record the size of each artifact: length, width, thickness, and weight. I followed Loy and Powell's (1977) definitions of physical attributes (Figure 3):

- Length – the greatest dimension of the artifact in either the horizontal or vertical plane.
- Width – the second greatest dimension of the artifact, measured perpendicular to the length.
- Thickness – the third greatest dimension of the artifact, measured perpendicular to both the length and the width.
- Weight – the mass of the artifact.

All dimensional attributes were recorded in millimeters; weight was recorded in grams. Artifact dimensions were recorded using vernier calipers with a precision of 0.02 mm; dimensions were later rounded to the nearest centimeter. Weight was recorded using a digital scale with a precision of 0.1 g.

Some artifacts were unavailable for physical examination and only photographs could be accessed. In these cases length, width, and thickness were estimated to nearest centimeter based on a scale bar. All estimated lengths are indicated in footnotes.

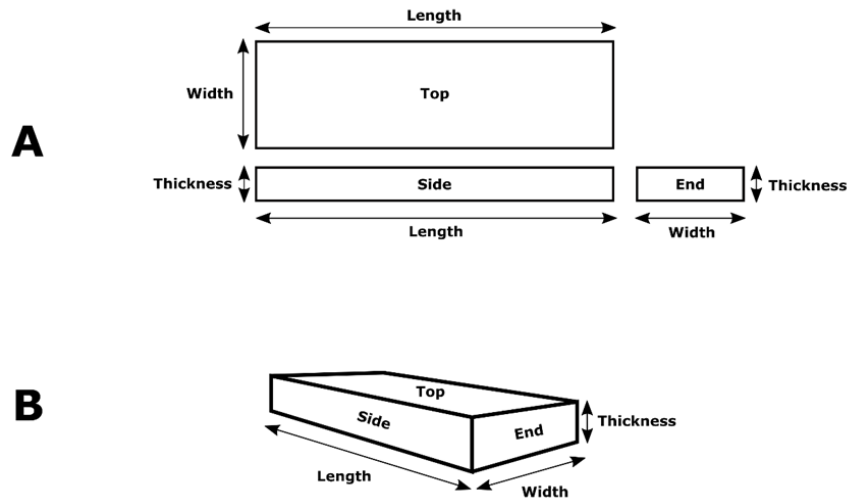

Figure 3. Generalized representation of the method used to record artifact dimensions: A) 2D planar view; B) 3D perspective view (Walter Homewood illustration).

The following terms are used to describe the orientation of the six faces of the artifact (Figure 3). An “end” is the artifact face bounded by the thickness and width; each artifact has two ends. A “side” is the face bounded by the length and thickness; each artifact has two sides. The “top” and “bottom” are the faces bounded by the length and width; top and bottom can be used interchangeably and do not refer to a universal orientation.

All artifacts available for examination in repositories were photographed. Material colour was recorded using the *Munsell Rock Color Book* (2019). Lithic material type was determined based on a visual inspection only for those artifacts available for examination by comparison to a reference text; those represented solely by photographs were excluded. The visual inspection was conducted first without magnification and then under 40x magnification with a hand lens. Reference texts used were the *National Audubon Society Field Guide to North American Rocks and Minerals* (Chesterman 1995) and the *National Geographic Pocket Guide to Rocks and Minerals of North America* (Garlick 2014).

3.5. Chapter Summary

The methods described above cover a literature review, the development of a classification system, discussions with knowledgeable individuals and the recording of

artifact attributes. Aside from the attribute measurements, these methods are qualitative in nature.

Collecting basic measurements and developing a classification system both contribute directly to my research question, how can the ribbed stone artifact class be defined and described? The literature review and discussions with knowledgeable individuals provide contextual information regarding why this study is important and what research on ribbed stones in the future should involve.

The conceptual outline of a form based classification system that I devised is an artificial classification system, it is not based on emic information or statistical inference. It is a top down approach that divides ribbed stones into smaller groupings of types based on characteristics of shape that can be determined through a visual inspection of the artifact. These characteristics are not dependant on each other nor is one more important than another. This allows for attributes to be examined in combination or individually. The choice to use such an approach was intentional so that the typology might be flexible to the needs of future researchers. Importantly the classification system provides a standardized list of terms that can be used to describe the form of ribbed stones.

Chapter 4. Results

This chapter presents the results of my data collection and classification. I first describe the key attributes of ribbed stones, and define the ribbed stone artifact class, and then present the classification system based on form. I next describe the different types of ribbed stones I identified. Finally, the spatial and temporal distribution of ribbed stones are provided.

4.1. Ribbed Stone Attributes

The key attributes of ribbed stones that I recorded in this study were length, width, thickness, weight, colour, and material (Table 7). Weight, colour, and material type were not recorded if the artifact could not be physically examined. Thickness was not measured if all faces of the artifact were not visible in photographs. An entry of “N/A” in Table 9, indicates missing values. In total, all attributes were recorded for 20 of the 31 ribbed stones in the sample, partial measurements were taken for the remaining 11.

For the 31 ribbed stones examined, length ranged from 3 to 15 cm, width from 2 to 7 cm, thickness from 1 to 7 cm, and weight from 7.6 to 383.6 g. Sandstone was the most common material type (n = 12), followed by siltstone (n = 6), scoria (a type of basalt) (n = 1), and lignite (n = 1). The material colour was generally shades of brown and grey.

Table 7. Attributes of ribbed stones.

ID	Length (cm)	Width (cm)	Thickness (cm)	Weight (g)	Colour Code (Munsell)	Colour Name (Munsell)	Material
1	13	3	3	168.4	5YR 4/4	Moderate Brown	Siltstone
2	11	4	2	102.7	10YR 4/2	Dark Yellowish Brown	Siltstone
3	8	4	2	70.6	5YR 5/2	Pale Brown	Sandstone
4	8	4	3	88.8	5YR 5/2	Pale Brown	Sandstone
5	9	4	3	87.3	5YR 6/4	Light Brown	Siltstone
6	10	4	3	125.3	5 YR 6/4	Light Brown	Siltstone
7	7	4	2	37.1	5YR 7/2	Greyish Orange Pink	Siltstone
9 [▲]	6	3	2	32.1	N6	Medium Light Grey	Sandstone
10	5	2	2	17.0	10YR 6/2	Pale Yellowish Brown	Sandstone
11*	12	4	3	n/a	n/a	n/a	n/a
17*	7	4	2	n/a	n/a	n/a	n/a
18 [▲]	6	6	3	114.1	10YR 4/2	Dark Yellowish Brown	Sandstone
19 [▲]	5	4	3	42.8	N4	Medium Dark Grey	Siltstone
20 [▲]	5	2	2	18.6	5YR 2/1	Brownish Black	Sandstone
21	5	2	1	7.6	N2	Greyish Black	Lignite
22	7	4	2	78.2	5YR 3/2	Greyish Brown	Sandstone
23 [‡]	5	3	N/A	N/A	N/A	N/A	N/A
24 [‡]	7	4	N/A	N/A	N/A	N/A	N/A
25 [‡]	8	3	N/A	N/A	N/A	N/A	N/A
26 ^{▲ ‡}	4	3	N/A	N/A	N/A	N/A	N/A
27	7	4	3	59.4	5Y 4/1	Olive Grey	Scoria (Basalt)
28	10	5	3	164.0	10YR 2/2	Dusky Yellowish Brown	Sandstone
29	15	6	5	383.6	10YR 6/2	Pale Yellowish Brown	Sandstone
30	10	6	3	134.5	5YR 2/2	Dusky Brown	Sandstone
31	3	3	1	24.6	5Y 3/2	Olive Grey	Sandstone
32	8	4	2	95.2	5Y 5/2	Light Olive Grey	Sandstone
35 ^{▲ ‡}	7	7	7	N/A	N/A	N/A	N/A
36 [‡]	11	4	2	N/A	N/A	N/A	N/A
37 ^{▲ ‡}	7	3	3	N/A	N/A	N/A	N/A
38 [‡]	3	2	N/A	N/A	N/A	N/A	N/A
39 [‡]	6	3	N/A	N/A	N/A	N/A	N/A
Max	15	7	7	383.6			
Min	3	2	1	7.6			

* Measurements were taken from a cast as the original artifact was on display at the Canadian Museum of History and were unavailable for analysis.

▲ Indicates fragmented artifact.

‡ Measurements estimated to nearest centimeter based on photographs.

4.2. Classification and Typology

This section is organized by three topics: 1) the ribbed stone artifact class definition; 2) the ribbed stone classification system; and 3) the description of ribbed stone types. The class definition is the basis for including an artifact within the ribbed stone class. The form of any ribbed stone can then be recorded using the classification system and organized into types based on its characteristics.

4.2.1. Class Definition

The class definition is a generalized description used to determine which artifacts will be included in the class. The definition that I developed for ribbed stones (Table 8) is based on commonly shared attributes, such as a rough and abrasive material type, manufacturing by grinding, and having a characteristic pattern of deeply incised grooves that extend across the entirety of at least one face of the artifact, creating a ribbed pattern of raised bands. The class definition follows the example of Deetz (1996:139-140) in which the artifact class is defined by material type, manufacturing technique, and then form, in that order.

Table 8. Ribbed stone class definition.

Ribbed Stone	
Material Type	A ribbed stone is most commonly made of sandstone or similar sedimentary rock such as siltstone. However, there have been examples of ribbed stones made of scoria (a type of basalt), and lignite (which is often found within sandstone). The texture of the material is rough and abrasive.
Manufacturing Technique	Ribbed stones are made by grinding, i.e., ribbed stones are shaped by rubbing the artifact with or against an abrasive surface.
Form	Ribbed stones are characterized by deeply incised grooves that extend across the entirety of at least one face of the artifact, creating a ribbed pattern of raised bands. The grooves are aligned parallel to each other and are most commonly aligned perpendicular to the length of the artifact. Ribbed stones vary in shape, but are typically an elliptical cylinder or tabular in profile. Ribbed stones range in size from approximately 3 to 15 cm in length, 2 to 7 cm in thickness, and 1 to 7 cm in width. Artifact weight ranges from approximately 7 to 384 grams.

4.2.2. The Ribbed Stone Classification System

The completed classification system is presented in Table 9. It can be applied to any artifact in the class to record basic morphological attributes and describe the form of the artifact. All 31 of the ribbed stones that I had access to or photos of were put through the classification system.

Entries are presented in a numbered order for reference and ease of use; entry numbers do not correspond to a ranked order of importance. Entries 1-5 can be used in conjunction with the class definition to determine if the artifact is part of the ribbed stone artifact class, while entries 6-10 describe artifact form and can be used to determine the ribbed stone type.

Table 9. Ribbed stone classification system.

Entry	Entry Name	Modifiers Used	Description
1	Category	Artifact	An object showing one or more of the following: evidence of intentional modification, evidence of use, evidence that it has been selected for possible use (Loy and Powell 1977:12).
2	Material Class	Stone	A consolidated or coherent and relatively hard, naturally formed mass or aggregate of mineral matter (Loy and Powell 1977:66).
3	Material Type	Sandstone	A clastic sedimentary rock with generally rounded particles of sand size (Chesterman 1995:715).
		Siltstone	A clastic sedimentary rock with particles of silt size (Chesterman 1995:714).
		Lignite	A form of coal, intermediate between peat and bituminous coal. Seams are often found interbedded with sandstone (Chesterman 1995:728-729).
		Scoria (Basalt)	A type of basalt with a rough and abrasive texture. (Chesterman 1995:688).
4	Manufacturing Technique	Ground	A method of artifact modification by rubbing with or against an abrasive surface (Low and Powell 1977:51).
5	Artifact Class	Ribbed Stone	See ribbed stone class definition described (Table 8).
6	Shape	Circular Cylinder	A circular cylinder profile.
		Elliptical Cylinder	An elliptical cylinder profile.
		Tabular	A rectangular prism profile.
		Amorphous	The artifact has an irregularly shaped profile.
7	Groove Location	1-Sided	Grooves on one side.
		2-Sided	Grooves on two sides.
		4-Sided	Grooves on four sides; the grooves are not continuous.
		Girdled	Continuous grooves encircling the artifact.
8	Groove Direction	Perpendicular	Grooves are perpendicular to the length of the artifact.
		Parallel	Grooves are parallel to the length of artifact.
		Bidirectional	Both perpendicular and parallel grooves in the artifact.
9	Groove Width	Single-width	Grooves are all approximately the same width.
		Multi-width	There is a difference in approximate groove widths on different sides.
10	Decoration	Geometric	The artifact has geometric design.
		Zoomorphic	The artifact has a design that resembles an animal.
		Undecorated	The artifact is not decorated.

4.2.3. Typology

Each ribbed stone was described and assigned a type based on my classification system (Table 10). Types are based on one or more attribute recorded in Entries 6-10. Ribbed stones that share attributes are the same type. As this classification system is based on a dissociated approach, attributes can be combined in a variety of ways to

form different groupings. When taken together, Entries 6-10 provide a description of the general form of each ribbed stone.

Not all fields could be completed for every ribbed stone described in Table 10 (those marked as "N/A") for reasons that included:

1. where only a cast or photograph was available, meaning that material could not be identified;
2. where only photographs were available and not all faces of the artifact were visible, meaning that such attributes as shape, placement of grooves, and/or the size of grooves could not be determined; and
3. where the artifact was too fragmented to a make a determination on one or more attributes.

Table 10. Results of the classification system.

ID	Artifact Class					Ribbed Stone Type				
	1. Cat.	2. Mat. C.	3. Mat. T.	4. Man. T.	5. Class	6. Shape	7. Groove Location	8. Groove Direction	9. Groove Width	10. Decoration
1	Artifact	Stone	Siltstone	Ground	Ribbed Stone	Tabular	2- Sided	Perpendicular	Multi-Width	Geometric
2	Artifact	Stone	Siltstone	Ground	Ribbed Stone	Tabular	2- Sided	Perpendicular	Single-Width	Undecorated
3	Artifact	Stone	Sandstone	Ground	Ribbed Stone	Amorphous	1- Sided	Perpendicular	Single-Width	Undecorated
4	Artifact	Stone	Sandstone	Ground	Ribbed Stone	Amorphous	1- Sided	Perpendicular	Single-Width	Undecorated
5	Artifact	Stone	Siltstone	Ground	Ribbed Stone	Elliptical Cylinder	2- Sided	Perpendicular	Single-Width	Geometric
6	Artifact	Stone	Siltstone	Ground	Ribbed Stone	Elliptical Cylinder	2- Sided	Perpendicular	Single-Width	Geometric
7	Artifact	Stone	Siltstone	Ground	Ribbed Stone	Tabular	2- Sided	Perpendicular	N/A	Undecorated
9	Artifact	Stone	Sandstone	Ground	Ribbed Stone	Tabular	N/A	Perpendicular	N/A	Undecorated
10	Artifact	Stone	Sandstone	Ground	Ribbed Stone	Tabular	1- Sided	Perpendicular	Single-Width	Undecorated
11	Artifact	Stone	N/A	Ground	Ribbed Stone	Amorphous	2- Sided	Perpendicular	Multi-Width	Zoomorphic
17	Artifact	Stone	N/A	Ground	Ribbed Stone	Tabular	4- Sided	Bidirectional	Multi-Width	Undecorated
18	Artifact	Stone	Sandstone	Ground	Ribbed Stone	Tabular	2- Sided	Perpendicular	Multi-Width	Undecorated
19	Artifact	Stone	Siltstone	Ground	Ribbed Stone	Elliptical Cylinder	2- Sided	Perpendicular	Multi-Width	Undecorated
20	Artifact	Stone	Sandstone	Ground	Ribbed Stone	Elliptical Cylinder	N/A	Perpendicular	N/A	Geometric
21	Artifact	Stone	Lignite	Ground	Ribbed Stone	Tabular	1- Sided	Perpendicular	Single-Width	Undecorated
22	Artifact	Stone	Sandstone	Ground	Ribbed Stone	Elliptical Cylinder	Girdled	Perpendicular	Single-Width	Undecorated

ID	Artifact Class					Ribbed Stone Type				
	1. Cat.	2. Mat. C.	3. Mat. T.	4. Man. T.	5. Class	6. Shape	7. Groove Location	8. Groove Direction	9. Groove Width	10. Decoration
23	Artifact	Stone	N/A	Ground	Ribbed Stone	Amorphous	Girdled	Perpendicular	Single-Width	Undecorated
24	Artifact	Stone	N/A	Ground	Ribbed Stone	Elliptical Cylinder	2- Sided	Perpendicular	Single-Width	Undecorated
25	Artifact	Stone	N/A	Ground	Ribbed Stone	Amorphous	1- Sided	Perpendicular	Single-Width	Undecorated
26	Artifact	Stone	N/A	Ground	Ribbed Stone	Tabular	N/A	Perpendicular	N/A	Undecorated
27	Artifact	Stone	Scoria (Basalt)	Ground	Ribbed Stone	Elliptical Cylinder	Girdled	Perpendicular	Single-Width	Undecorated
28	Artifact	Stone	Sandstone	Ground	Ribbed Stone	Elliptical Cylinder	Girdled	Perpendicular	Single-Width	Undecorated
29	Artifact	Stone	Sandstone	Ground	Ribbed Stone	Elliptical Cylinder	2- Sided	Perpendicular	Multi-Width	Undecorated
30	Artifact	Stone	Sandstone	Ground	Ribbed Stone	Amorphous	N/A	Bidirectional	Single-Width	Undecorated
31	Artifact	Stone	Sandstone	Ground	Ribbed Stone	Amorphous	2- Sided	Perpendicular	Single-Width	Undecorated
32	Artifact	Stone	Sandstone	Ground	Ribbed Stone	Amorphous	1- Sided	Perpendicular	Single-Width	Undecorated
35	Artifact	Stone	N/A	Ground	Ribbed Stone	Circular Cylinder	Girdled	Bidirectional	Single-Width	Undecorated
36	Artifact	Stone	N/A	Ground	Ribbed Stone	Elliptical Cylinder	2- Sided	Perpendicular	Single-Width	Undecorated
37	Artifact	Stone	N/A	Ground	Ribbed Stone	Elliptical Cylinder	2- Sided	Perpendicular	Multi-Width	Undecorated
38	Artifact	Stone	N/A	Ground	Ribbed Stone	Tabular	N/A	Perpendicular	N/A	Undecorated
39	Artifact	Stone	N/A	Ground	Ribbed Stone	Tabular	N/A	Perpendicular	N/A	Undecorated

Below, I summarize the results of my ribbed stone typology. I begin by providing counts and examples of each type based on single attributes: shape; groove location; groove direction; groove width; and decoration. I then list what I refer to as the “descriptive types.”

I identified four shapes of ribbed stones: elliptical cylinder; tabular; amorphous; and circular cylinder (Table 11; Figures 4-7). Elliptical cylinder and tabular are the most common shapes, with 11 examples of each. Amorphous is the next most common shape (n=8). One circular cylinder was observed (ID 35).

Table 11. Ribbed stone types: shape.

Shape (Entry 6))	Count	IDs
Elliptical Cylinder	11	5; 6; 19; 20; 22; 24; 27; 28; 29; 36; 37
Tabular	11	1; 2; 7; 9; 10; 17; 18; 21; 26; 38; 39
Amorphous	8	3; 4; 11; 23; 25; 30; 31; 32
Circular Cylinder	1	35

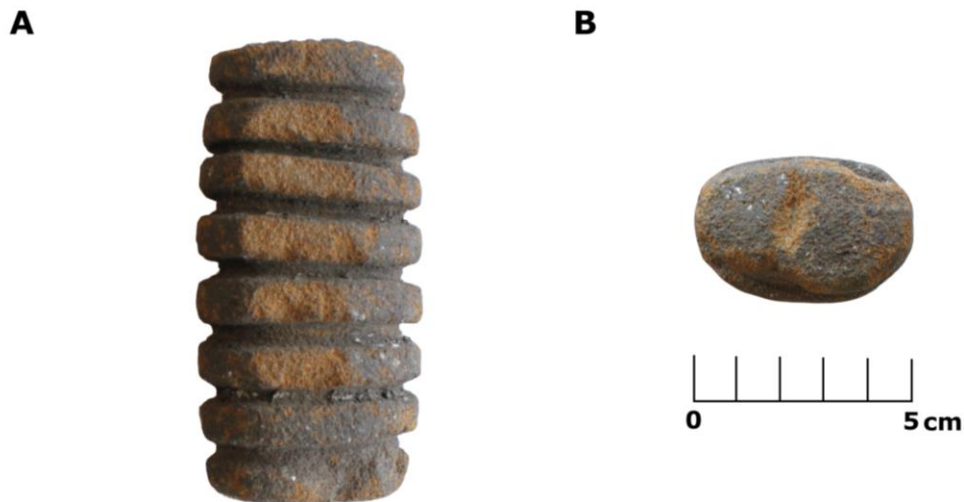

Figure 4. Elliptical cylinder shape example, ID 29: A) top profile; B) end profile (Walter Homewood photo).

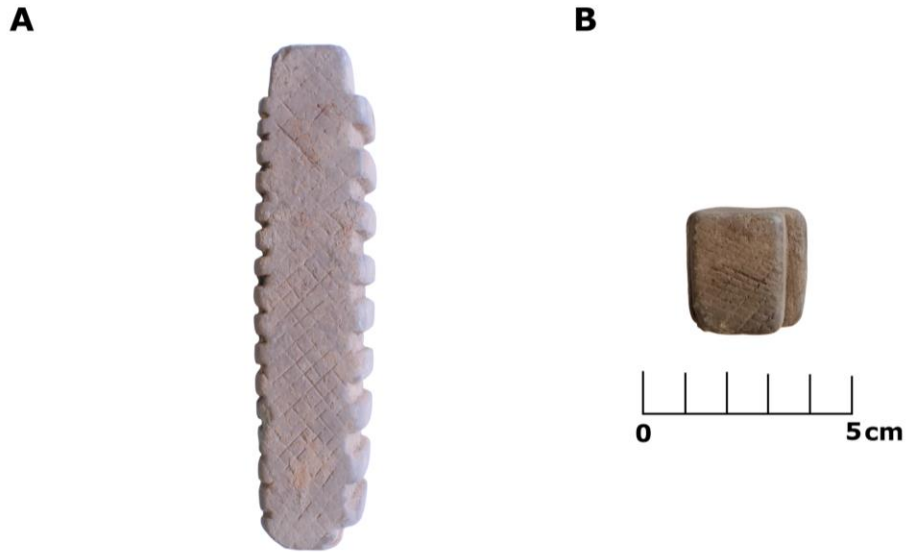

Figure 5. Tabular shape example, ID 1: A) top profile; B) end profile (Walter Homewood photo).

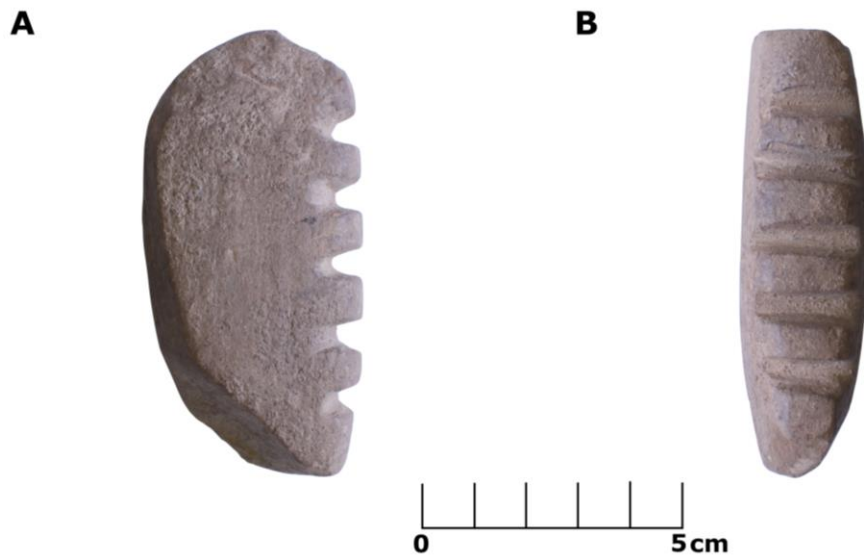

Figure 6. Amorphous shape example, ID 3: A) top profile; B) side profile (Walter Homewood photo).

A**B**

Figure 7. Circular cylinder shape example, ID 35: A) top profile; B) end profile (Andrew Eckert photo, copyright Millennia Research Limited, used with permission).

There are four types of groove locations: 1-sided; 2-sided; 4-sided; and girdled (Table 12; Figures 8-11). 2-sided is largest category (n=13), followed by 1-sided (n=6) and girdled (n=5). One of the ribbed stones (ID 17) was observed to have non-continuous grooves on four faces of the artifact, meaning it could not be considered “girdled” and was instead recorded as 4-sided.

Table 12. Ribbed stone types: groove location.

Groove Location (Entry 7)	Count	IDs
1-sided	6	3; 4; 10; 21; 25; 32
2-sided	13	1; 2; 5; 6; 7; 11; 18; 19; 24; 29; 31; 36; 37
4-sided	1	17
Girdled	5	22; 23; 27; 28; 35

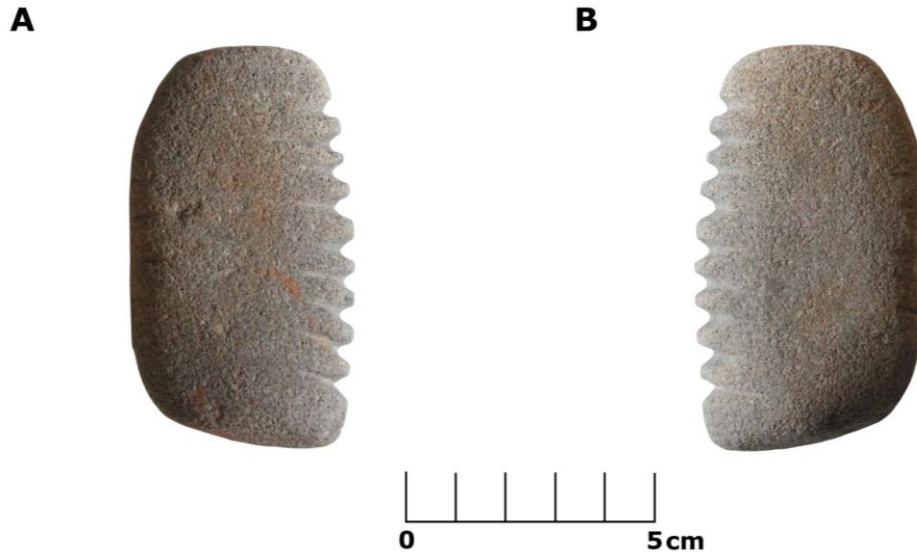

Figure 8. 1-sided example ID 32: A) top profile; B) bottom profile (Walter Homewood photo).

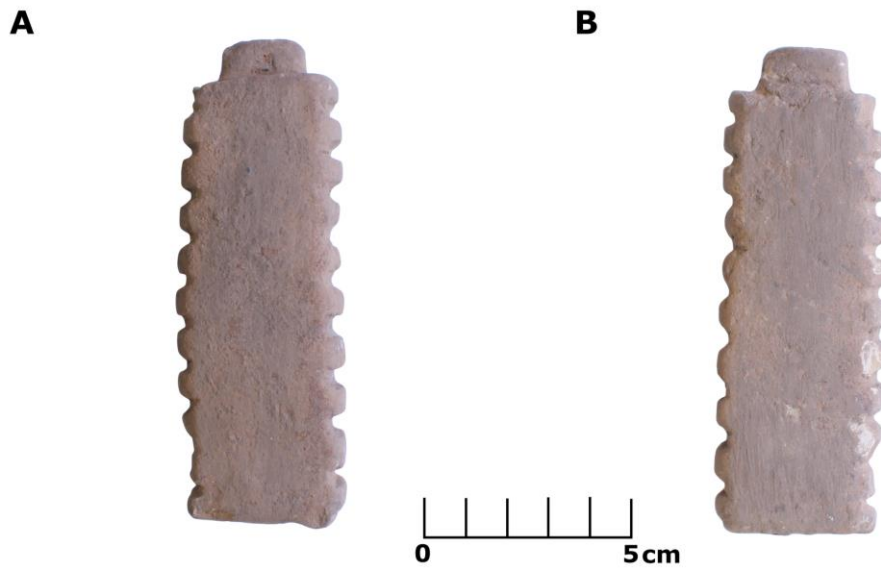

Figure 9. 2-sided example, ID 2: A) top profile; B) bottom profile (Walter Homewood photo).

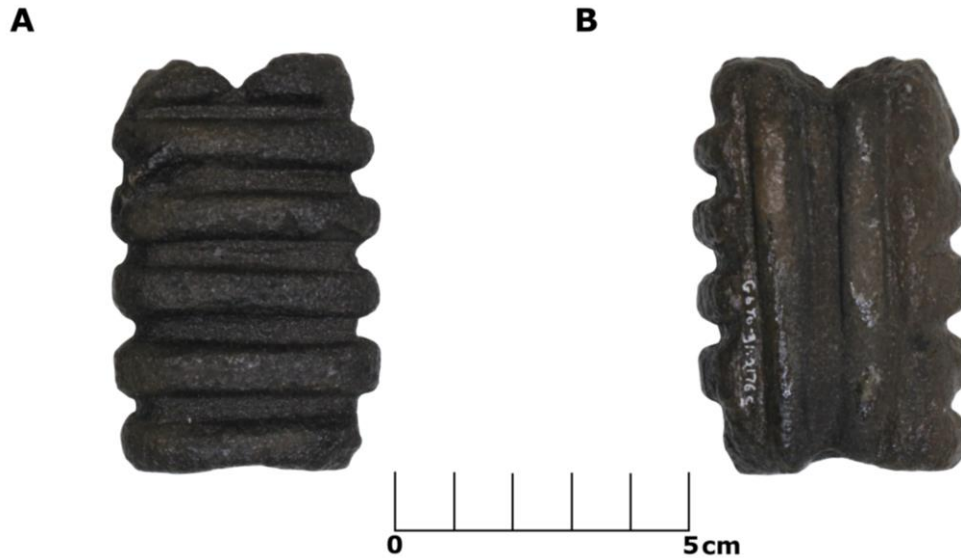

Figure 10. 4-sided example, ID 17 (photo is of a cast): **A)** top profile; **B)** bottom profile (Walter Homewood photo, courtesy of the Canadian Museum of History).

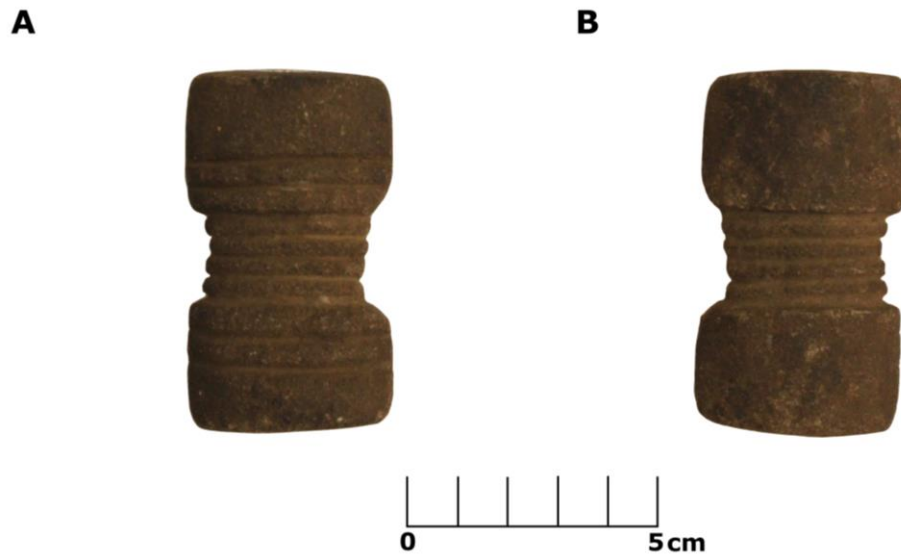

Figure 11. Girdled example, ID 22: **A)** top profile; **B)** bottom profile (Walter Homewood photo).

Two types of groove directions were identified: perpendicular and bidirectional (Table 13; Figures 12-13). Ribbed stones primarily have a perpendicular groove direction (n=28). Three were observed to have bidirectional grooves. There were no ribbed stones with exclusively parallel grooves.

Table 13. Ribbed stone types: groove direction.

Groove Directions (Entry 8)	Count	IDs
Perpendicular	28	1; 2; 3; 4; 5; 6; 7; 9; 10; 11; 18; 19; 20; 21; 22; 23; 24; 25; 26; 27; 28; 29; 31; 32; 36; 37; 38; 39
Bidirectional	3	17; 30; 35



Figure 12. Perpendicular grooves example, ID 7: top profile (Walter Homewood photo, courtesy of the Canadian Museum of History).



Figure 13. Bidirectional grooves example, ID 30: top profile (Walter Homewood photo).

There are two types of groove widths: single-width and multi-width (Table 14; Figures 14-15). Single-width is the most common type (n=18). Seven ribbed stones had grooves of two or more distinct widths.

Table 14. Ribbed stone types: groove widths

Groove Widths (Entry 9)	Count	IDs
Single-width	18	2; 3; 4; 5; 6; 10; 21; 22; 23; 24; 25; 27; 28; 30; 31; 32; 35; 36
Multi-width	7	1; 11; 17; 18; 19; 29; 37



Figure 14. Single-width example, ID 5: top profile (Walter Homewood photo).



Figure 15. Multi-width example, ID 18: top profile (Walter Homewood photo, courtesy of the Canadian Museum of History).

There are three decoration types: undecorated; geometric; and zoomorphic (Table 15; Figures 16-18). Most ribbed stones are undecorated (n=26). A geometric decoration was observed on four artifacts. One example of a zoomorphic decoration was recorded (ID 11). It had been described by MacDonald (1983:113) as having “a backbone, mouth gash and eyes” giving the figure the “appearance of a creature of some kind, or a monster.”

Table 15. Ribbed stone types: decoration.

Decoration (Entry 10)	Count	IDs
Undecorated	26	2; 3; 4; 7; 9; 10; 17; 18; 19; 21; 22; 23; 24; 25; 26; 27; 28; 29; 30; 31; 32; 35; 36; 37; 38; 39
Geometric	4	1; 5; 6; 20
Zoomorphic	1	11

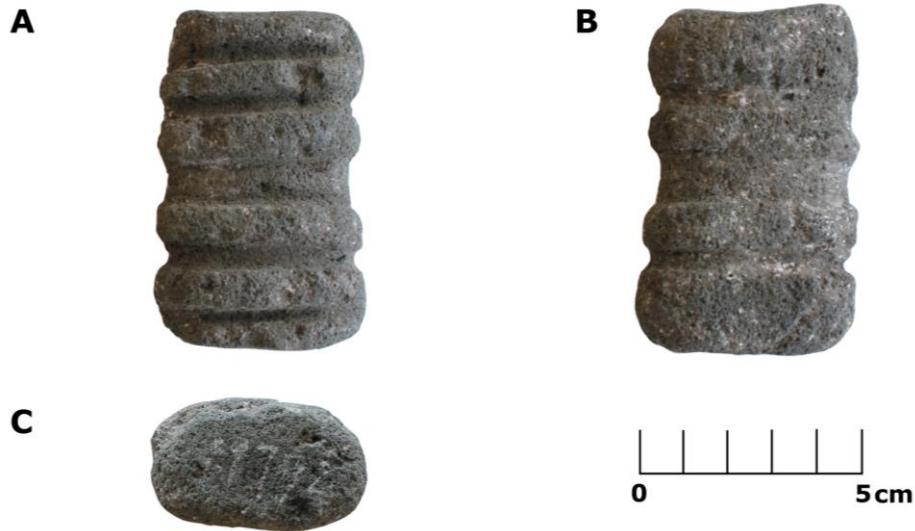

Figure 16. Undecorated example, ID 27: A) top profile; B) bottom profile; C) end profile. (Walter Homewood photo)

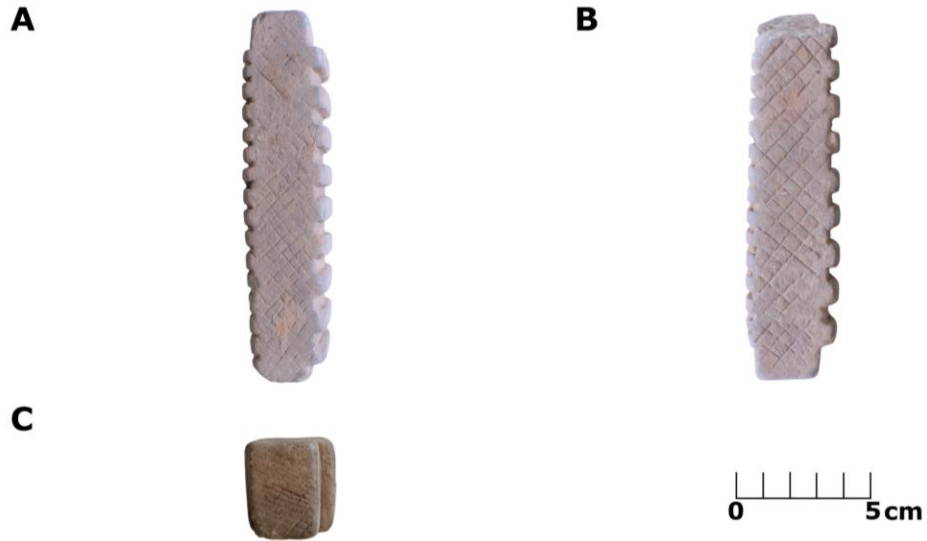

Figure 17. Geometric decoration example, ID 1: A) top profile; B) bottom profile; C) end profile (Walter Homewood photo).



Figure 18. Zoomorphic decoration example, ID 11 (photo is of a cast): A) top profile, B) bottom profile; C) front profile; D) back profile. (Walter Homewood photo, courtesy of the Canadian Museum of History).

Descriptive Types

In total, I identified 14 types of ribbed stones, when split by all levels of classification (as opposed to lumping), based on my classification system (Table 16; Figures 19-32), I refer to these as the “descriptive types,” as the attributes, when taken together, produce a complete description of the form of the artifact. Only ribbed stones for which all fields from level 5-6 of the classification system could be completed were

included as part of identifying these 14 types. Twenty-four were either complete enough or had photographs suitable to allow recording of all characteristics. A “type code” has been applied to each type as a shorthand reference.

The single most common descriptive type is an amorphous, 1-sided, perpendicular, single-width, undecorated, ribbed stone (Type A [n = 4]). The next most common types are variations on the elliptical cylinder, most of which are 2-sided or girdled (Type B). Nine of the ribbed stones are their own types (Types D, G, H, I, J, K, L, M, N). There is considerable variation within the ribbed stone artifact class. The number of identified types suggests that the form of ribbed stones is highly variable.

Table 16. Ribbed stone descriptive types.

Type Description	Type Code	Count	IDs
amorphous, 1-sided, perpendicular, single-width, undecorated	A	4	3, 4, 25, 32
elliptical cylinder, 2-sided, perpendicular, multi-width, undecorated	B	3	19; 29; 37
elliptical cylinder, girdled, perpendicular, single-width, undecorated	C	3	22; 27; 28
elliptical cylinder, 2-sided, perpendicular, single-width, undecorated	D	1	24
elliptical cylinder, 2-sided, perpendicular, single-width, geometric	E	2	5; 6
tabular, 1-sided, perpendicular, single-width, undecorated	F	2	10, 21
circular cylinder, girdled, bidirectional, single-width, undecorated	G	1	35
amorphous, 2-sided, perpendicular, single-width, undecorated	H	1	31
amorphous, 2-sided, perpendicular, multi-width, zoomorphic	I	1	11
amorphous, girdled, perpendicular, single-width, undecorated	J	1	23
tabular, 2-sided, perpendicular, single-width, undecorated	K	1	2
tabular, 2-sided, perpendicular, multi-width, geometric	L	1	1
tabular, 2-sided, perpendicular, multi-width, undecorated	M	1	18
tabular, 2-sided, bidirectional, multi-width, undecorated	N	1	17

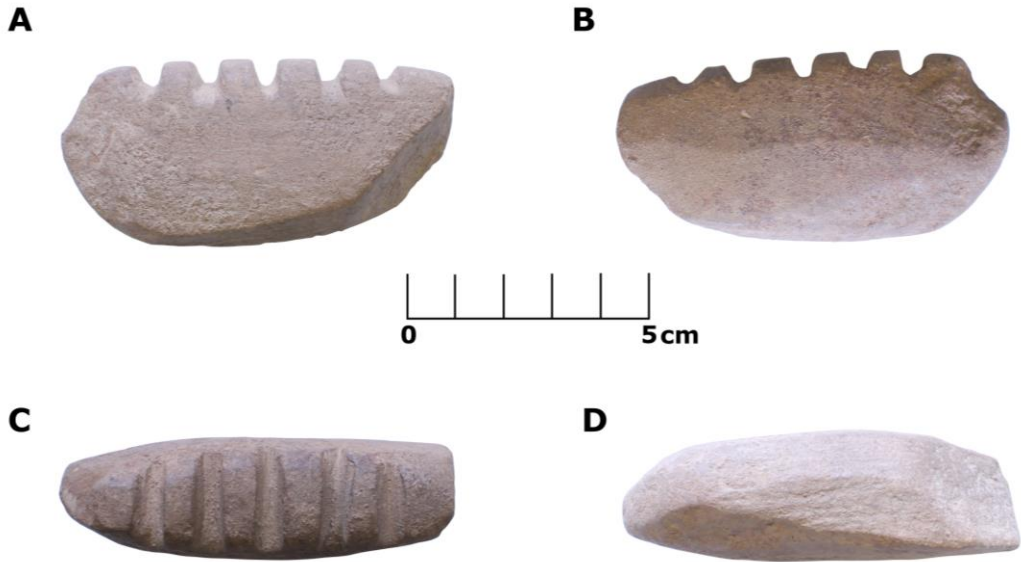

Figure 19. Type A example, ID 3: A) top profile; B) bottom profile; C) front profile; D) back profile (Walter Homewood photo).



Figure 20. Type B example, ID 19: A) top profile; B) bottom profile; C) end profile (Walter Homewood photo, courtesy of the Canadian Museum of History).

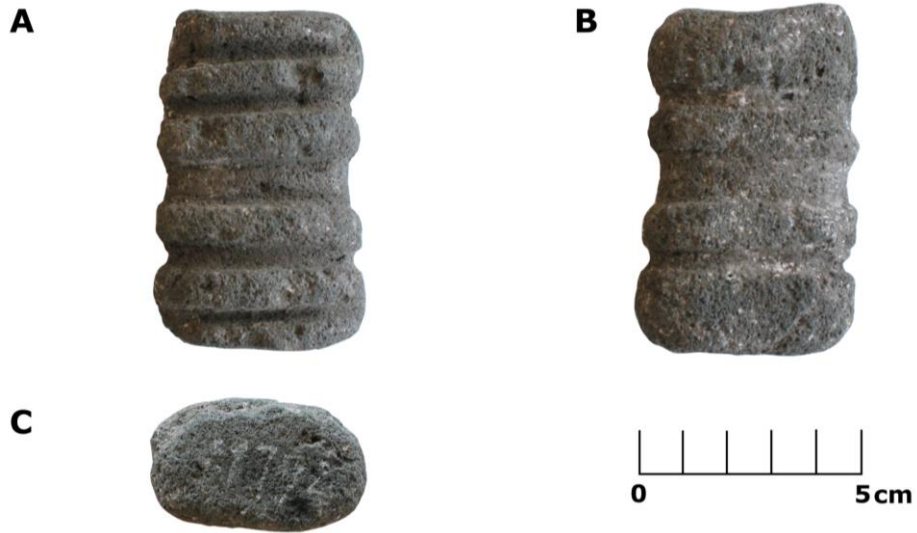

Figure 21. Type C example, ID 27: A) top profile; B) bottom profile; C) end profile (Walter Homewood photo).

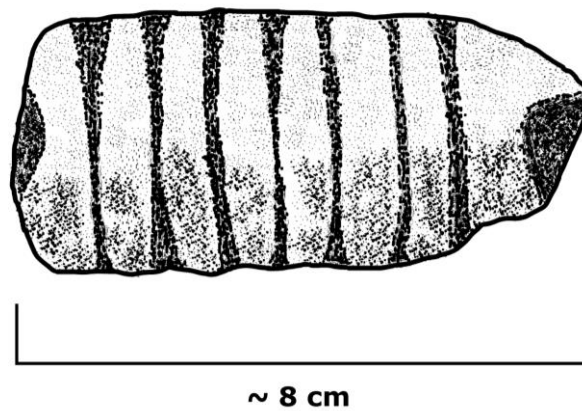

Figure 22. Type D example, ID 24: top profile sketch of artifact on display (Candiain Musuem of History 2020a), (Illustration by Walter Homewood).

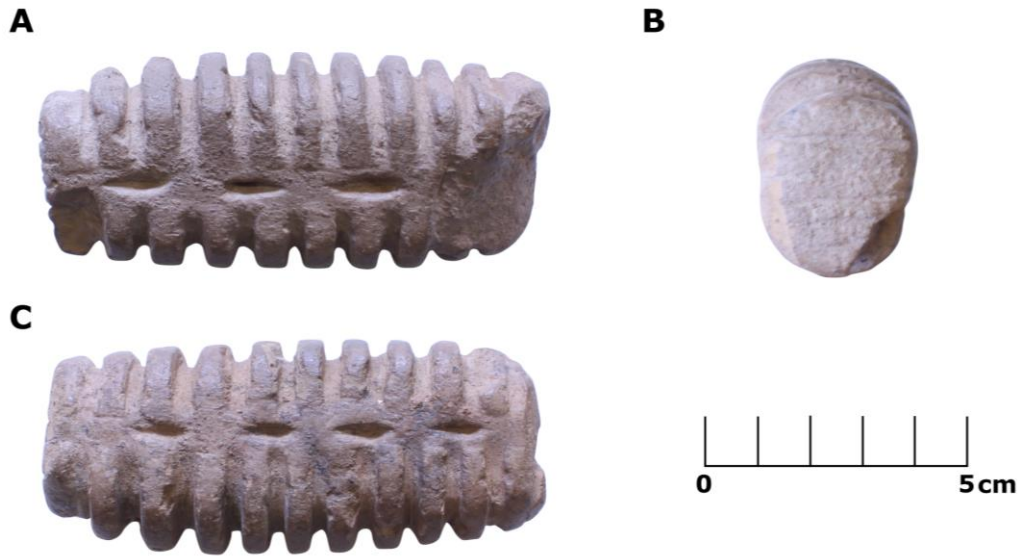

Figure 23. Type E example, ID 5: A) top profile; B) end profile; C) bottom profile. (Walter Homewood photo)

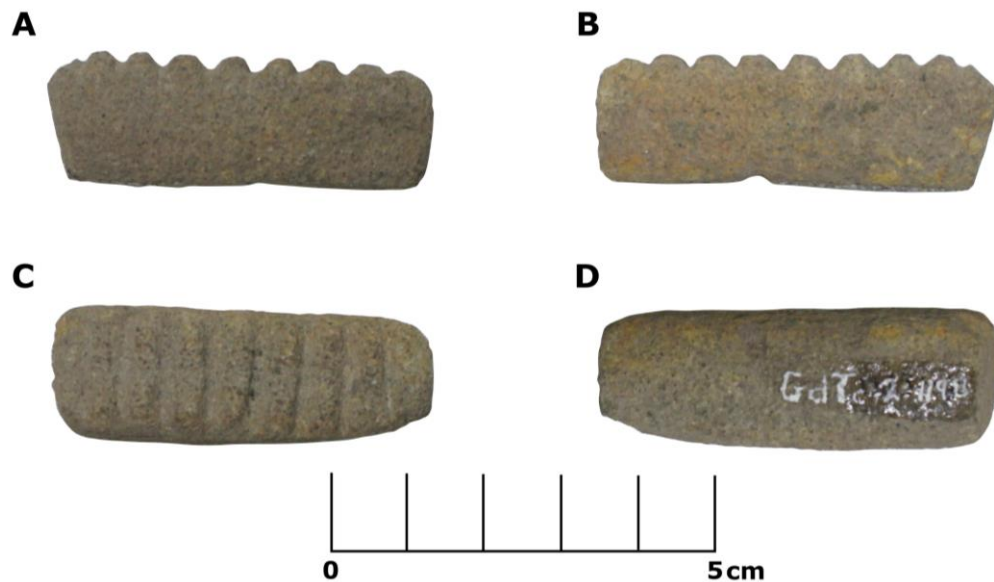

Figure 24. Type F example, ID 10: A) top profile; B) bottom profile; C) front profile; D) back profile (Walter Homewood photo, courtesy of the Canadian Museum of History).

A

B



Figure 25. Type G example, ID 35: A) top profile; B) end profile. (Andrew Eckert photo, copyright Millennia Research Limited, used with permission)

A

B

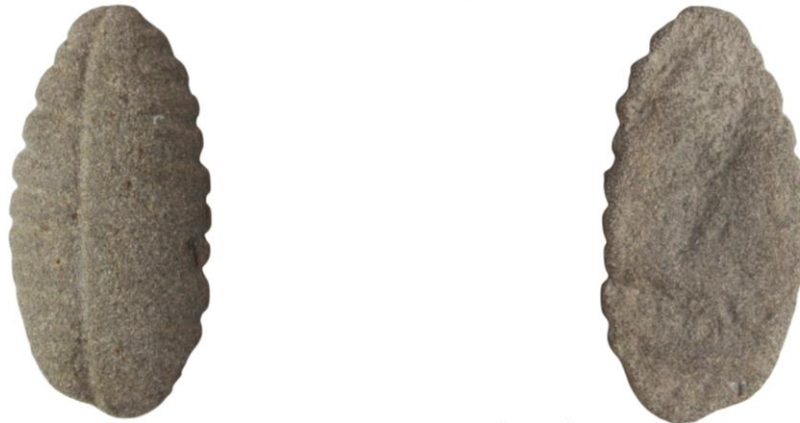

Figure 26. Type H example, ID 31: A) top profile; B) bottom profile. (Walter Homewood photo)



Figure 27. Type I example, ID 11 (photo is of a cast): A) top profile, B) bottom profile; C) front profile; D) back profile (Walter Homewood photo, courtesy of the Canadian Museum of History).

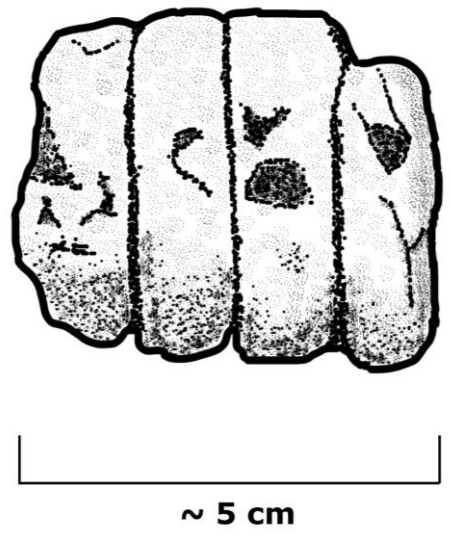

Figure 28. Type J example, ID 23: Top profile sketch of artifact on display (Canadian Museum of History 2020a), (Walter Homewood illustration).

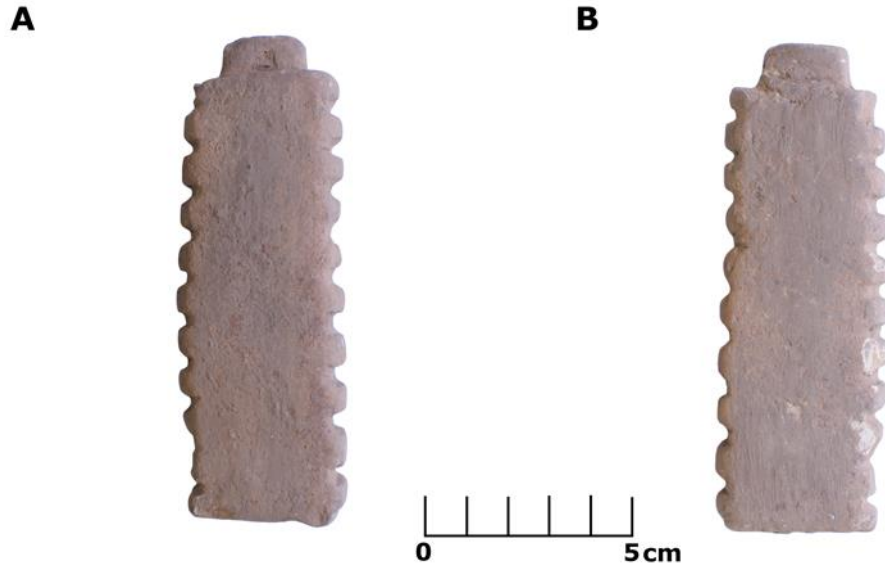

Figure 29. Type K example, ID 2: A) top profile; B) bottom profile (Walter Homewood photo).

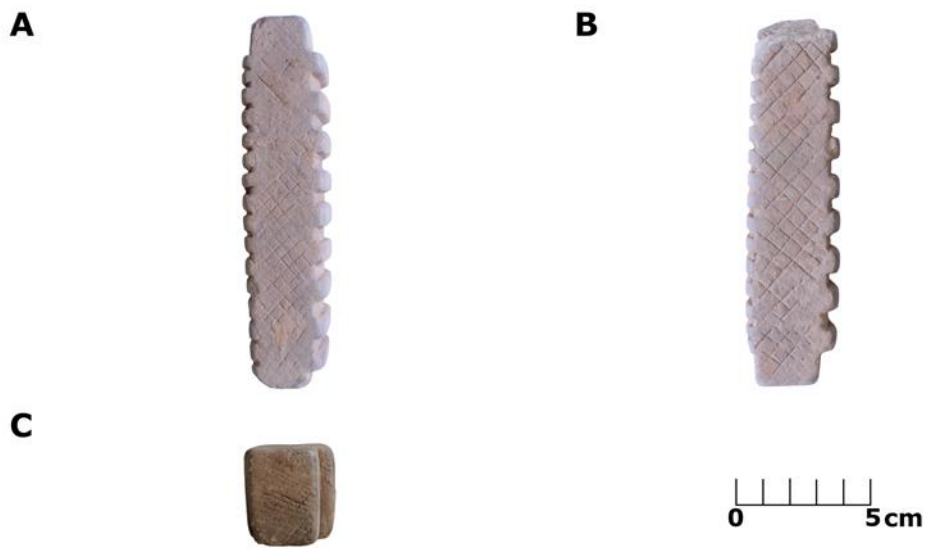

Figure 30. Type L example, ID 1: A) top profile; B) bottom profile; C) end profile (Walter Homewood photo).

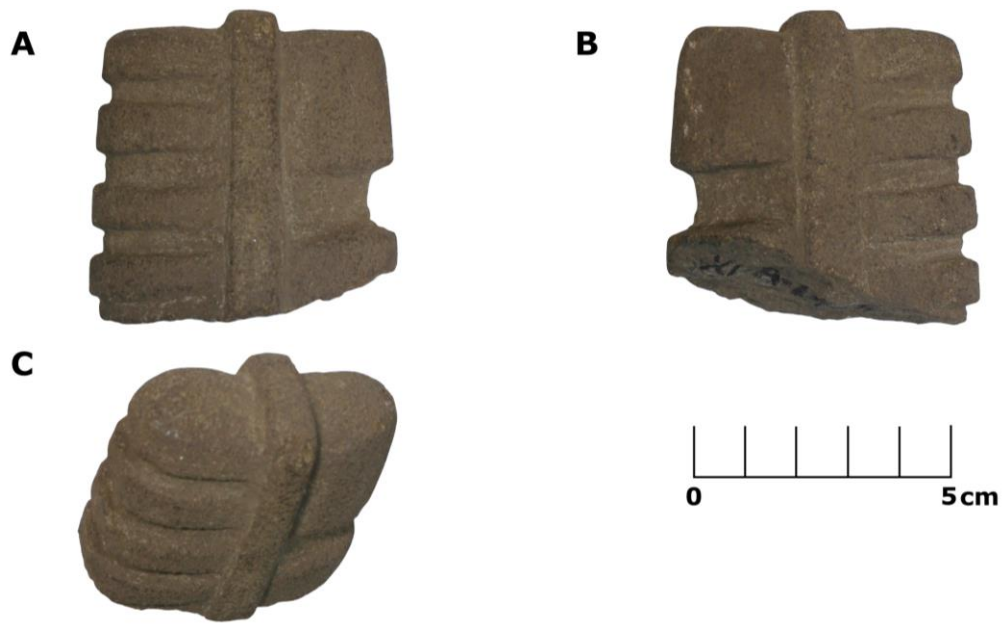

Figure 31. Type M example, ID 18: A) top profile; B) bottom profile; C) end profile (Walter Homewood photo, courtesy of the Canadian Museum of History).

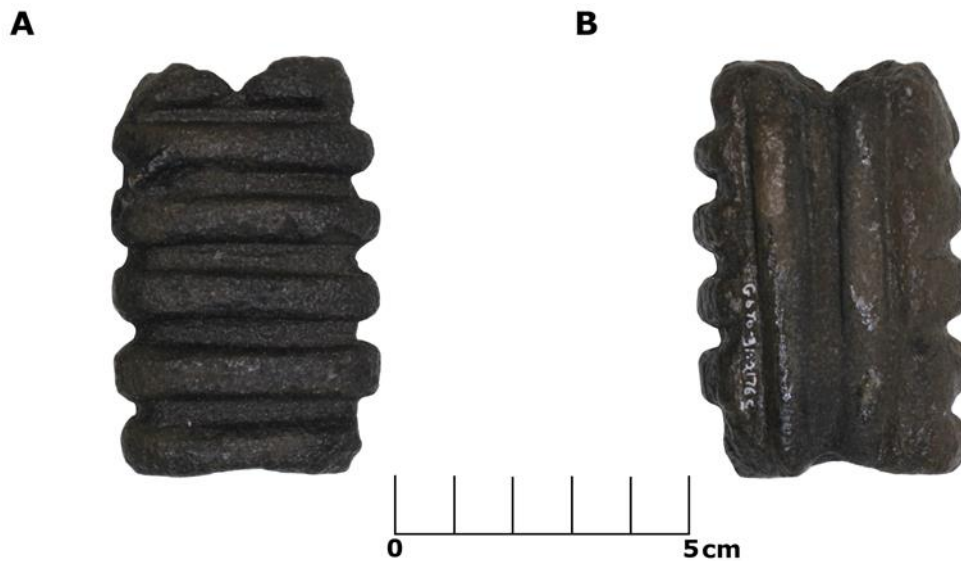

Figure 32. Type N example, ID 17 (photograph is of a cast): A) top profile; B) bottom profile (Walter Homewood photo, courtesy of the Canadian Museum of History).

4.3. Spatial and Temporal Distribution

This section details the spatial and temporal distribution of ribbed stones. Spatial data for ribbed stones were recorded with varying levels of precision. There are some instances where only general area can be assigned, but many are attributed to sites and

some to levels within sites. Date ranges for ribbed stones are uncertain, due in part to artifacts being surface finds or coming from a disturbed archaeological context. For ribbed stones recorded in controlled excavation, I was able to identify date ranges. These provide, at the very least, an earliest known date for the appearance of ribbed stones in the archaeological record.

4.3.1. Spatial Distribution

The spatial distribution of ribbed stones is primarily limited to the Skeena River watershed and Prince Rupert Harbour. There are, however two isolated examples from outside this general area: one collected at Masset on Haida Gwaii; the other a surface find at Húyat on the Central Coast. One of the ribbed stones in the collections of the Royal BC Museum only has location information of being from the Northern Northwest Coast. Locational information is presented in Table 17 and Figure 33. I describe, in greater detail, locations that I was able to visit in person.

Table 17. Provenience and number of ribbed stones in British Columbia.

General Area	Specific Location*	Count	IDs
Moricetown Canyon	east terrace	2	1; 2
	west terrace (GgSt-5)	2	3; 4
	N/A**	1	18
Hagwilget	high eastern terrace	2	5; 6
Kitselas Canyon	Gitau's (GdTc-2)	5	7; 9; 10; 11; 20
	Paul Mason Site (GdTc-16)	1	39
Skeena (west of Terrace)	N/A	1	32
Prince Rupert Harbour	Boardwalk Site (GbTo-31)	3	17; 21; 26
	no additional location data	3	25; 28; 30
	Ya asqalu'i/Kaien Siding (GbTo-54)	3	35; 36; 37
	Reservoir Site (GbTo-33)	1	23
	Charles Point (GbTo-16)	1	31
	(GcTo-31)	1	24
	Dodge Island (GbTo-18)	1	29
	Crippen Cove (GbTo-19)	1	27
Haida Gwaii	Masset	1	19
Central Coast	Húyat	1	38
Northern Northwest Coast	N/A	1	22

*Borden Number is included where available.

**"N/A" = no specific location information available.

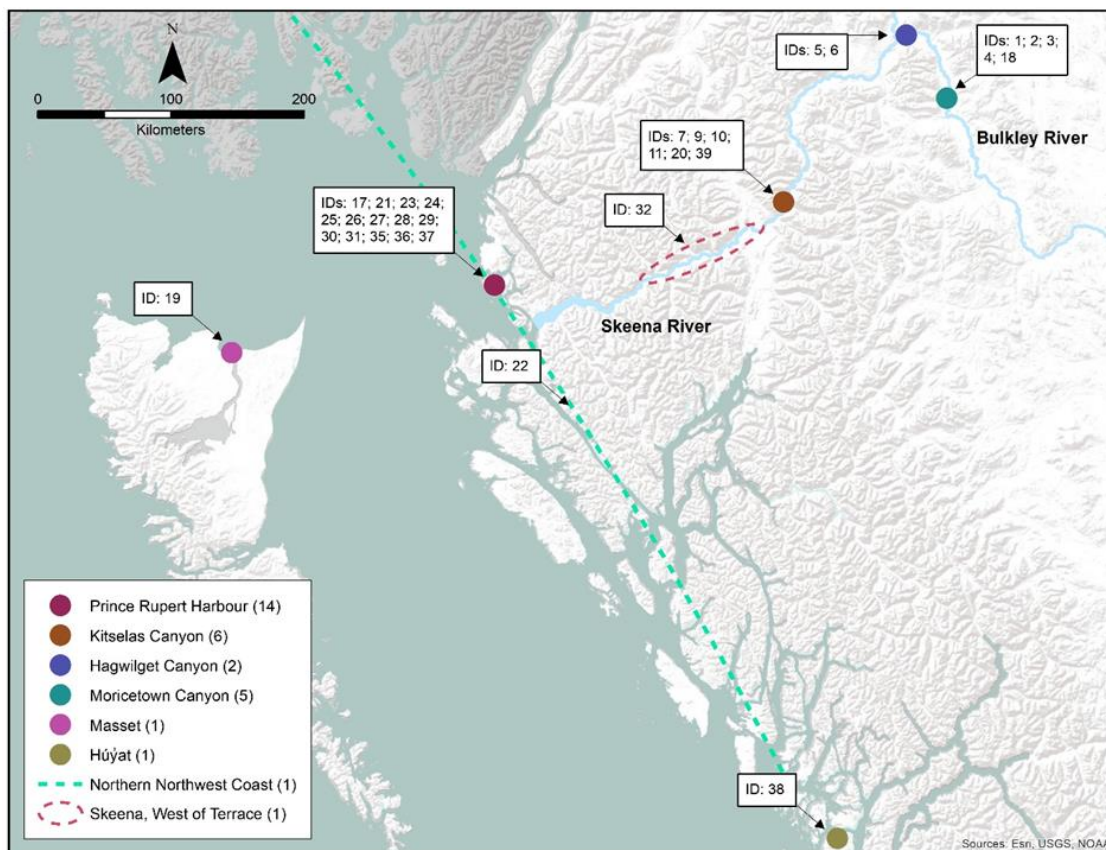

Figure 33. Spatial distribution of ribbed stones.

Prince Rupert Harbour

Prince Rupert Harbour is located approximately 25 km north of the mouth of the Skeena River (Figure 34). A total of 14 ribbed stones have been recorded here, at seven archaeological sites. Large-scale excavations in the area were conducted as part of the North Coast Prehistory Project (1966–1972) directed by George MacDonald. Prince Rupert Harbour has the highest count of ribbed stones in the Northwest Coast: three come from the Boardwalk Site (GbT0-31) (Figures 35-36); three from Ya asqalu’i (GbTo-54); three were surface finds with no site information recorded, one was found at Dodge Island (GbTo-18) (Figure 37); one at the reservoir site (GbTo-33); one at Charles Point (GbTo-16); one at Crippen Cove (GbTo-19); and one at GcTo-31.



Figure 34. Prince Rupert Harbour. (Walter Homewood photo)



Figure 35. The Boardwalk site (GbTo-31), looking was across Digby Cove. (Walter Homewood photo)



Figure 36. “Area D” trenches at the Boardwalk site (GbTo-31) (Ames 2005:67) excavated during the North Coast Prehistory Project. (Walter Homewood photo)



Figure 37. Dodge Island and archaeological site GbTo-18. (Walter Homewood photo)

Kitselas Canyon

Kitselas Canyon is an approximately 3-km-long narrowing of the Skeena River (Figure 38), part of the traditional territory of the Kitselas First Nation (*GitseLasu* in the

Tsimshian language Sm'algyax). There are active fishing stations along the length of the canyon.

Four archaeological habitation sites are in the canyon. Three are on the east side of the river: Gitsaex (GdTc-3) at the north end of the canyon, the Paul Mason site (GdTc-16) in the middle, and Gitaus (GdTc-2) at the south end. The fourth, Gitlaxdzawx (GdTc-1), is on the west side of the river towards the north end of the canyon. Allaire (1978) excavated at Gitaus in 1968 and Coupland (1988) at the Paul Mason site in 1982 and 1983. The Gitaus Site has the highest count of ribbed stones ($n = 5$) from any single archaeological site.



Figure 38. Kitselas Canyon, looking down river from east of the Paul Mason site. The Gitaus site is beyond the bend in the river. (Walter Homewood photo)

Hagwilget Canyon

Hagwilget Canyon (Figure 39) is located on the Bulkley River approximately 5 km upstream from where the Bulkley meets the Skeena. *Hagwilget* is the Gitksan name for the location, and *Tsë Cahk* in the Wet'suwet'en language. The canyon is a location shared by the Gitksan and the Wet'suwet'en, a long-standing arrangement based on events recorded in the histories of both communities (Cassidy 2015; Hoffman and Joseph 2019:83). The canyon is currently spanned by the Hagwilget suspension bridge,

which replaced the frequently rebuilt wooden cantilever bridge that predated European presence at Hagwilget (Morin 2016:88-89).



Figure 39. Hagwilget Canyon, photo taken from the east side of the Bulkley River, below the terrace where ribbed stones (ID 5, 6) were collected (Walter Homewood photo).

Moricetown Canyon

Moricetown Canyon is a steep-walled canyon on the Bulkley River (Figure 40). Known as *Witset* in the Wet'suwet'en language, the location has long been used as a fishing station for salmon, which have to rest in the back eddies of the river as they make their way up the canyon rapids.

Five ribbed stones have been collected from the Moricetown area. One was collected by Harlan Smith in 1926 “near Moricetown” (Canadian Museum of History 2020c). More recently, two were found on a terrace on the west side of the Bulkley River (GgSt-5), and two on a terrace on the east side of the river (Rick Budhwa, pers. comm. 2019).



Figure 40. Moricetown Canyon from the terrace on the west side of the river (GgSt-5) where ribbed stones (ID 3; 4) were collected. View is towards the terrace on the east side of the river where ribbed stones (ID 1; 2) were collected. (Walter Homewood photo)

4.3.2. Temporal Distribution

The age range for ribbed stones is poorly defined. The 31 ribbed stones I examined come from excavations (in both intact and disturbed contexts) and surface collections. No dates can be directly assigned to those from surface collections or disturbed contexts. Only ten were recovered in controlled excavations and have associated dates.

The known temporal range for ribbed stones is presented in Table 28, arranged in ascending order of the earliest date attributed to the artifact. The dates associated with ribbed stones begin at 1500 BC and extend to as recent as AD 1830. Five ribbed stones (IDs 7, 9, 20, 23, 24) have been reported using the approximate calendar year. For the remaining dated ribbed stones, a range is provided. In the case of IDs 17, 21, and 27, this range encompasses the entirety of the time that ribbed stones are thought to have been in use.

Table 18. Date ranges for ribbed stones from excavated contexts.

Date Range	ID	Location	Source
1500 BC–750 BC	39	Kitselas Canyon	Coupland 1988:146, 165, 242, 378
1500 BC–AD 1830	17	Prince Rupert Harbour	MacDonald and Inglis 1981:45, 47, 52
	21		
	27		
1000 BC–AD1000	26	Prince Rupert Harbour	Canadian Museum of History 2020b
ca. AD 1	9	Kitselas Canyon	Allaire 1978:vii, 314
	23	Prince Rupert Harbour	Canadian Museum of History 2020a
	24		
ca. AD 500	7	Kitselas Canyon	Allaire 1978:vii, 314
	20		

4.4. Chapter Summary

My analysis of ribbed stones indicates that they are an artifact primarily found in archaeological sites on the Bulkley and Skeena Rivers and in Prince Rupert Harbour. They are most commonly made from sandstone and are either tabular or an elliptical cylinder in shape. All have deeply incised grooves that are perpendicular to the length and run across the entirety of at least one face of the artifact.

Overall, ribbed stones range in size from approximately 3 to 15 cm in length, 2 to 7 cm in thickness, and 1 to 7 cm in width. The material type used is commonly sandstone or siltstone (i.e., coarse to fine grained sedimentary rock), though other material types have been observed (e.g. scoria), the material texture is rough and abrasive. Ribbed stones, in all cases, were manufactured by grinding.

Based on the few dated examples, the earliest possible date for the appearance of ribbed stones in the archaeological record is 1500 B.C., with the latest dated to about AD 1830. All of the dated examples come from sites in either Prince Rupert Harbour or Kitselas Canyon.

I identified five attributes that I used to develop a ribbed stone classification system: shape, location of grooves, direction of grooves, relative groove width, and decoration. These attributes are combined to create types.

When split by all levels of my classification system, I identified 14 types of ribbed stones. Each of these descriptive types was assigned a letter (A–N) to serve as a shorthand reference. The large number of descriptive types demonstrate the breadth of

variability in the ribbed stone artifact class or the possibility that not all attributes may be necessary for identifying types.

Chapter 5. Discussion

In this chapter, I first describe the purpose of my ribbed stone classification system, i.e., how I designed the system to be used. Second, I demonstrate the utility of my system by providing examples of how typologies can be organized and applied. Third, I consider the limitations of classifying artifacts based on form. Finally, I introduce a different classification system, circles of belonging, as a response to the limitations of morphological classification. I explain the concepts that inspired the design of this new system, demonstrate how it functions using ribbed stones as an example, and conclude with its own limitations.

5.1. Purpose of the Classification System

I created the classification system foremost to answer my research question, what are ribbed stones and what are the attributes of their form? In the previous chapter I defined the artifact class and described each type of ribbed stone. I also designed the classification system to have utility beyond this study alone. Use in future research and the possibility of there being many more than 31 ribbed stones were taken into account.

A guiding principle in designing the classification system was that it should provide standardized language for recording the physical description of the artifact and a means for comparing artifacts between sites (Adams and Adams 1991:318; Andrefsky 2005:85). To achieve this, I utilized a method of classification that Addams and Addams (1991:215) refer to as a “basic typology,” which is used “to express or learn something about the material being classified.”

Below, in section 5.2, I demonstrate how my classification system performs as a basic typology by examining differences in artifact form by region and time period. Since there may be differences in ribbed stone form that other researchers want to explore (e.g., the relation of form and function), I designed my classification system to be both broad and flexible so that it might be used in variety of ways. I took a polythetic and disassociated approach to classification (Andrefsky: 2005:67-73). Of the six attributes (shape; groove location; groove direction; groove width; decoration), none are considered more important than or depend on another. This means that the attributes

can be used individually or combined in a variety of ways depending on the needs of the researcher.

The combinations of the six different attributes resulted in a maximum of 14 types. This is a relatively large number considering that the sample size in this study is only 31 artifacts. I used six descriptive attributes and 16 modifiers in an attempt to create a classification system with enough well-defined terms that, should more ribbed stones be found by archaeologists, there wouldn't be a need to develop new definitions ad hoc. This decision was made based on two comments regarding the number of ribbed stones that may have already been recovered. First, in my conversation with George MacDonald (detailed in Chapter 6), he mentioned that in Tsimshian territory ribbed stones were quite common, that he had seen many on the beaches in Prince Rupert Harbour. These surface finds went unrecorded. Second, a report from Millenia Research (described in Chapter 2) stated that, "there are many segmented stones from beaches in private collections from Prince Rupert and on display at Prince Rupert's Museum of Northern BC (M. Eldridge personal observation)" (2014:324).

Based on these references to a larger number of ribbed stones on the beaches of Prince Rupert Harbour, I saw a need for my classification system to have to account for an unknown amount of variability. To address this, I designed the system to be thorough in describing the form of these artifacts, rather than as a means for creating a single typology. As a result, the maximum number of types climbed to 14.

My classification system was intentionally designed to be flexible in its application. It has the ability to create different groupings based on combinations of attributes that can be tailored to suit future research questions. The system also takes into account an expanding sample size, as there may be a large number of ribbed stones yet to formally catalogued.

5.2. Utility of the Classification System

In this section I discuss the utility of the classification system. There are 14 descriptive types of ribbed stones, when split by all levels of my classification system. However, ribbed stones can also be grouped by each attribute individually (i.e. other

attributes are lumped together): shape (Entry 6), groove location (Entry 7), groove direction (Entry 8), groove width (Entry 9), or decoration (Entry 10).

Below I examine the attributes individually, looking for regional or temporal differences in the types. I then do the same for the “descriptive types.” The ability to group ribbed stones by single or combinations of attributes was intentional. Different interpretations can be made by creating different typologies. Indeed, individual characteristics reveal some regional preferences for form, whereas the combined characteristics show the overall variability of the artifact class.

5.2.1. Shape

There are four shapes of ribbed stones: elliptical cylinder, tabular, amorphous, and circular cylinder. The distribution of the different shapes across the landscape is plotted in Figure 41. The circular cylinder shape only appears in Prince Rupert Harbour, albeit it this is the single example of this shape in the entire collection of 31 ribbed stones. All other shapes (i.e., elliptical cylinder, tabular, amorphous) appear uniformly across the sites where ribbed stones have been found.

There does not appear to be any differentiation in shape by location. Elliptical cylinder, tabular, and amorphous ribbed stones can be found across the entire spatial distribution of the artifact class. In the absence of regional differences, it is more likely that differences in ribbed stone shape is determined by the preference of the individual makers.

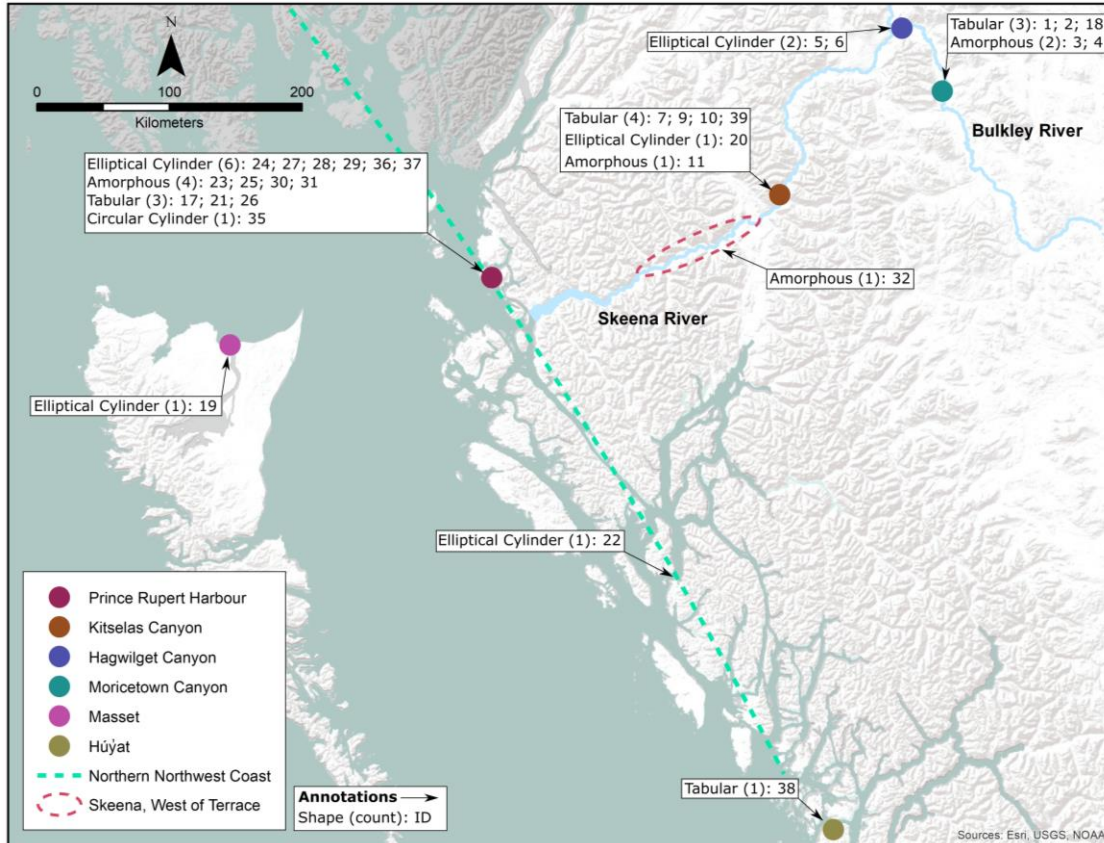

Figure 41. Spatial distribution of ribbed stones by shape.

Of the ten ribbed stones with associated dates, six are tabular, three are elliptical cylinders, and one is amorphous (Table 19). The tabular shape has a variety of dates attributed: it appears at Kitselas Canyon sometime between 1500-750 BC (ID 39) and is still at Kitselas canyon in AD 1 (ID 9) and in AD 500 (ID 7). At Prince Rupert Harbour, the tabular shape dates between 1500 BC and AD 1830. More precise dates, as opposed to large date ranges, are needed to more conclusively determine when the tabular shape first appeared.

There is a date of ca. AD 1 for ID 24 at Prince Rupert Harbour, indicating that the elliptical cylinder shape is present at that time. As well, the elliptical cylinder shape is present at Kitselas Canyon at AD 500 (ID 20). More dated examples of ribbed stones are needed to determine if the elliptical cylinder shape developed in Prince Rupert Harbour and then later brought to Kitselas Canyon.

Table 19. Date ranges of ribbed stones by shape.

Shape	Attributed Dates	ID
Tabular	1500 BC-AD 1830	17
		21
	1500-750 BC	39
	1000 BC-AD 1000	26
	AD 1	9
	AD 500	7
Elliptical Cylinder	1500 BC-AD 1830	27
	AD 1	24
	AD 500	20
Amorphous	AD 1	23

Four shapes can be observed across the spatial distribution of ribbed stones. There is no pattern indicating that there is a preference for a specific shape at different locations. It is more likely that individuals chose to make their ribbed stone in the shape that best suited their needs. The tabular shape appears to be persistent through time while the others are not. However, this may be due to the tabular shape being overrepresented in the ribbed stones that have attributed dates.

5.2.2. Groove Location

There are four types of ribbed stones when the location of the grooves is considered: 1-sided, 2-sided, 4-sided, and girdled. When plotted by location (Figure 42), girdled and 4-sided ribbed stones appear only at the coastal sites. There are five girdled ribbed stones; four appear in Prince Rupert Harbour and one from the “Northern Northwest Coast.” The lone 4-sided ribbed stone was found in Prince Rupert Harbour.

The 2-sided ribbed stone, the most common form, has been found at almost all locations where ribbed stones are present. The 1-sided form, though less common, has a similar spatial distribution. A 1-sided or 2-sided ribbed stone may have originated from anywhere that ribbed stones are found, while a girdled ribbed stone most likely originated in Prince Rupert Harbour. Girdling ribbed stones may be an indicator of a regional difference in how ribbed stones were crafted or used.

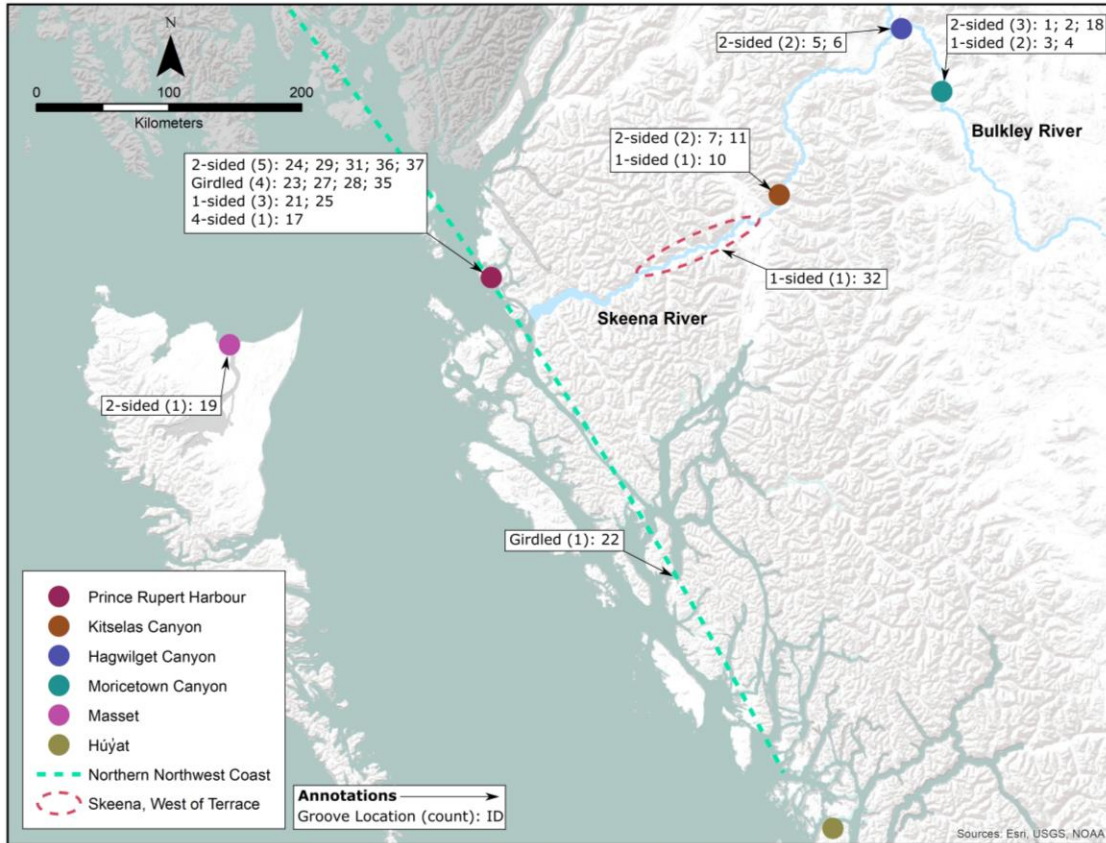

Figure 42. Spatial distribution of ribbed stones by groove location.

Groove location was recorded on only six of the ten ribbed stones with attributed dates (Table 20). The 2-sided form appears at Prince Rupert Harbour around AD 1 (ID 24) and at Kitselas Canyon at about AD 500 (ID 7). One of the girdled ribbed stones from Prince Rupert Harbour is dated to ca AD 1 (Canadian Museum of History 2020a). The rest of the dated ribbed stones from Prince Rupert Harbour have date ranges between 1500 BC and AD 1830.

Table 20. Date ranges of ribbed stones by groove location.

Groove Location	Attributed Dates	ID
Girdled	1500 BC-AD 1830	27
	AD 1	23
1-sided	1500 BC-AD 1830	21
2-sided	AD 1	24
	AD 500	7
4-sided	1500 BC-AD 1830	17

Based on groove location there appears to be some regional preference for form. Sites inland on the Skeena River and Bulkley River only had 1-sided or 2-sided ribbed

stones whereas all varieties of groove locations were found at Prince Rupert Harbour and girdling is only present at the coastal sites.

5.2.3. Groove Direction

There are two types of ribbed stones defined by groove direction: perpendicular and bidirectional. The predominant groove direction is perpendicular (n=28). Only three ribbed stones are bidirectional and all are found in Prince Rupert Harbour (Figure 43). As observed with girdled ribbed stones, Prince Rupert Harbour appears to be the unique case. If a ribbed stone has bidirectional grooves, then the most likely place of origin is Prince Rupert Harbour. Perpendicular grooves are ubiquitous of the ribbed stone artifact class and the perpendicular form is likely to be found at any site that has ribbed stones.

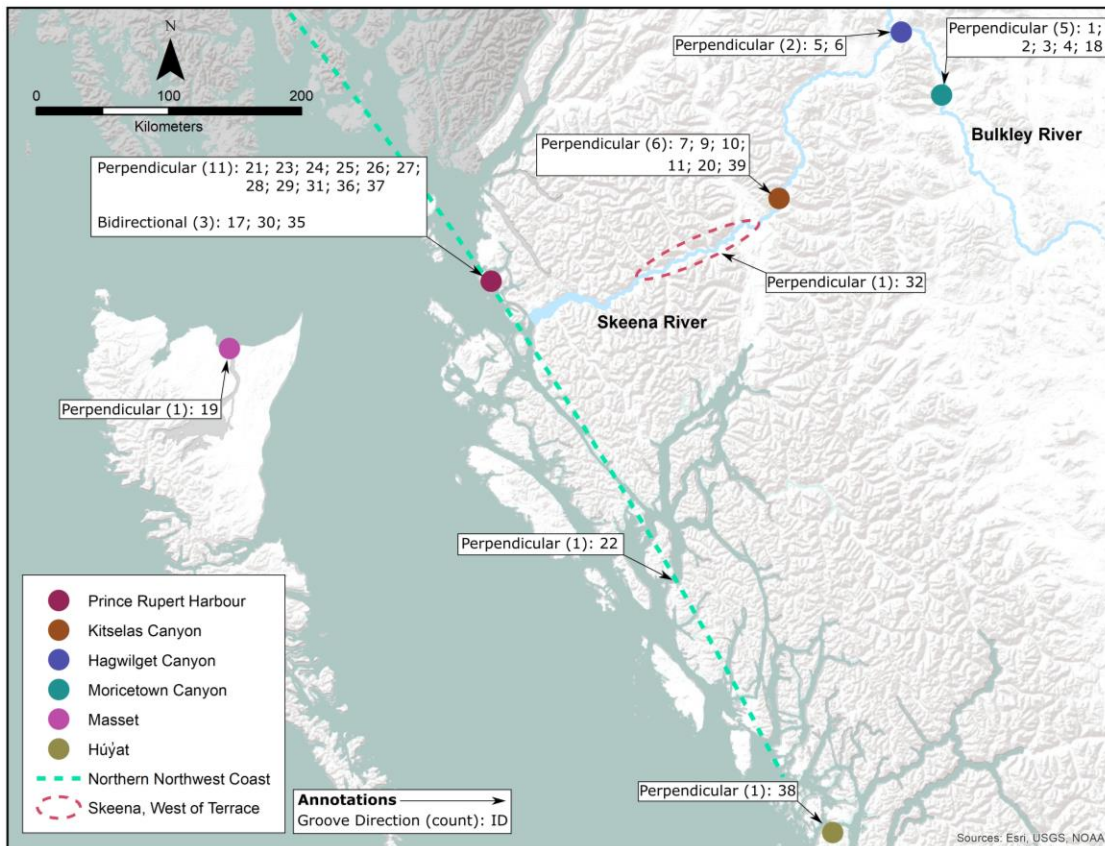

Figure 43. Spatial distribution of ribbed stones by groove direction.

The dates attributed to ribbed stones based on groove direction (Table 21) provide no insight into how the artifact class may have changed through time. This is due to the overwhelming majority (90%) of ribbed stones having perpendicular grooves

and the large date ranges attributed to both types. One of the bidirectional ribbed stones has a date range attributed, but it encompasses the entire time period known for the artifact class, meaning that this data point does not provide information as to whether bidirectional grooves developed from perpendicular grooves.

Table 21. Date ranges of ribbed stones by groove direction.

Groove Direction	Attributed Dates	ID
Perpendicular	1500 BC-AD 1830	21
		27
	1500–750 BC	39
	1000 BC-AD 1000	26
	AD 1	9
		23
		24
	AD 500	7
		20
	Bidirectional	1500 BC-AD 1830

Ribbed stones with perpendicular grooves are the dominant across all sites. This suggests that groove direction is influenced more by necessity rather than personal preference as it is a characteristic of ribbed stones that is not as variable as others (e.g., groove location). While the function of ribbed stones is unknown, the consistency of groove direction suggests that a groove direction perpendicular to the length of the artifact is necessary for that function.

5.2.4. Groove Width

There are two types of ribbed stones based on groove width: single-width and multi-width. Single-width ribbed stones (n=18) are more than twice as common as multi-width ribbed stones (n=7). Both types are found uniformly across the known distribution area (Figure 44). There is no regional preference for single-width or multi-width ribbed stones. As with other characteristics (e.g., shape), it appears that having a single uniform groove width or not is subject to some personal preference or different functions for the two types.

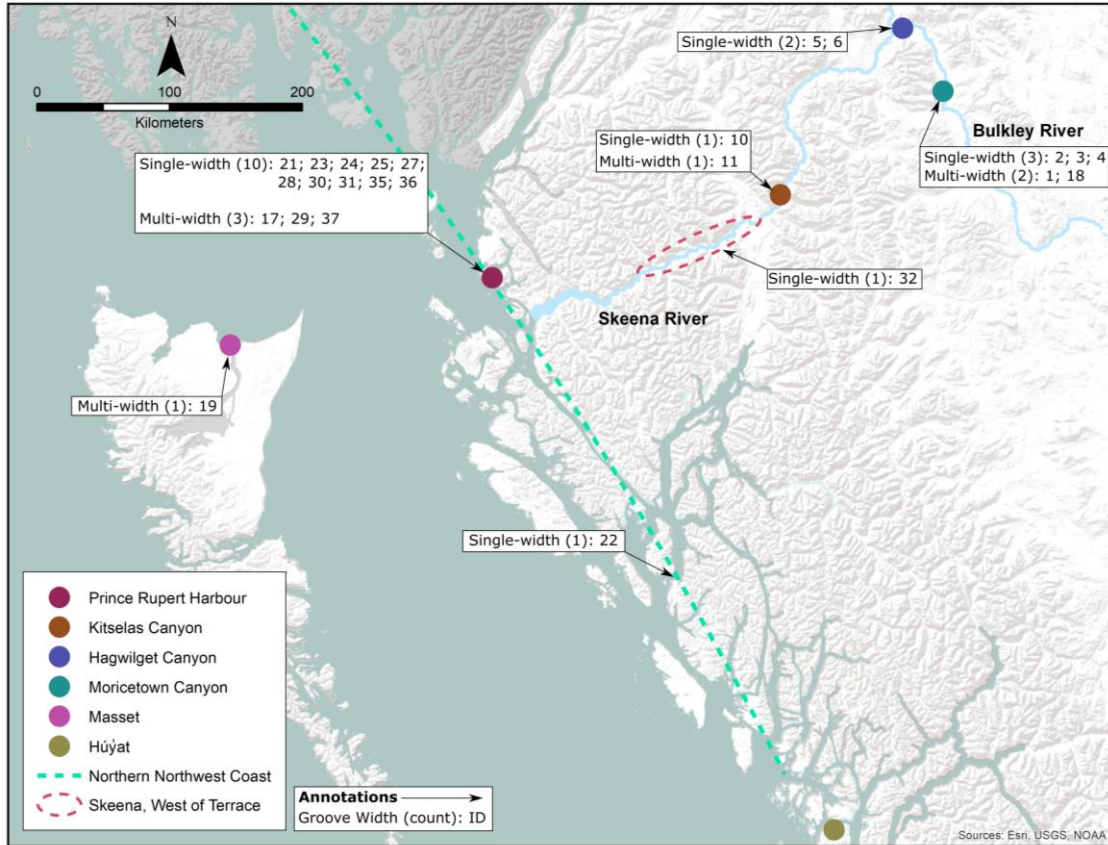

Figure 44. Spatial distribution of ribbed stones by groove width.

Groove width could be recorded for five of the ten ribbed stones that have attributed dates or date ranges (Table 22). Four are single-width and one is multi-width. The small number of examples and the large date range attributed to many of the artifacts limits what can be said about the appearance of this characteristic and whether one type was developed before the other. All that can be said with any certainty is that single-width ribbed stones were present at Prince Rupert Harbour at around AD 1 (IDs 23, 24).

Table 22. Date ranges of ribbed stones by groove width.

Groove Width	Attributed Dates	ID
Single-width	1500 BC-AD 1830	21
		27
	AD 1	23
		24
Multi-width	1500 BC-AD 1830	17

Unlike groove direction, groove width is more variable. This may be because groove width is determined more by preference than by function. More dated examples would be needed to determine if one type of groove width was developed before the other.

5.2.5. Decoration

There are three types of ribbed stones based on decoration: undecorated, geometric, and zoomorphic. Decorated ribbed stones (i.e., geometric and zoomorphic) only appear inland at Kitselas Canyon, Hagwilget Canyon, and Moricetown Canyon (Figure 45). The one zoomorphic decoration (ID 11) is that of a creature or “monster” that Macdonald (1983:113) described as having a “backbone, mouth gash and eyes.”

I observed no decorated ribbed stones in the collections of artifacts from coastal sites. Kitselas Canyon exhibited the greatest amount of variation with undecorated, geometric, and zoomorphic designs being found at that location. However, the zoomorphic decoration (ID 11) is the only example of that type.

There appears to be a regional preference for adding incised decorative lines to ribbed stones. Decoration may be a practice that began at the canyon sites along the Skeena and Bulkley Rivers but was never adopted by people making or using ribbed stones at coastal sites in places like Prince Rupert Harbour.

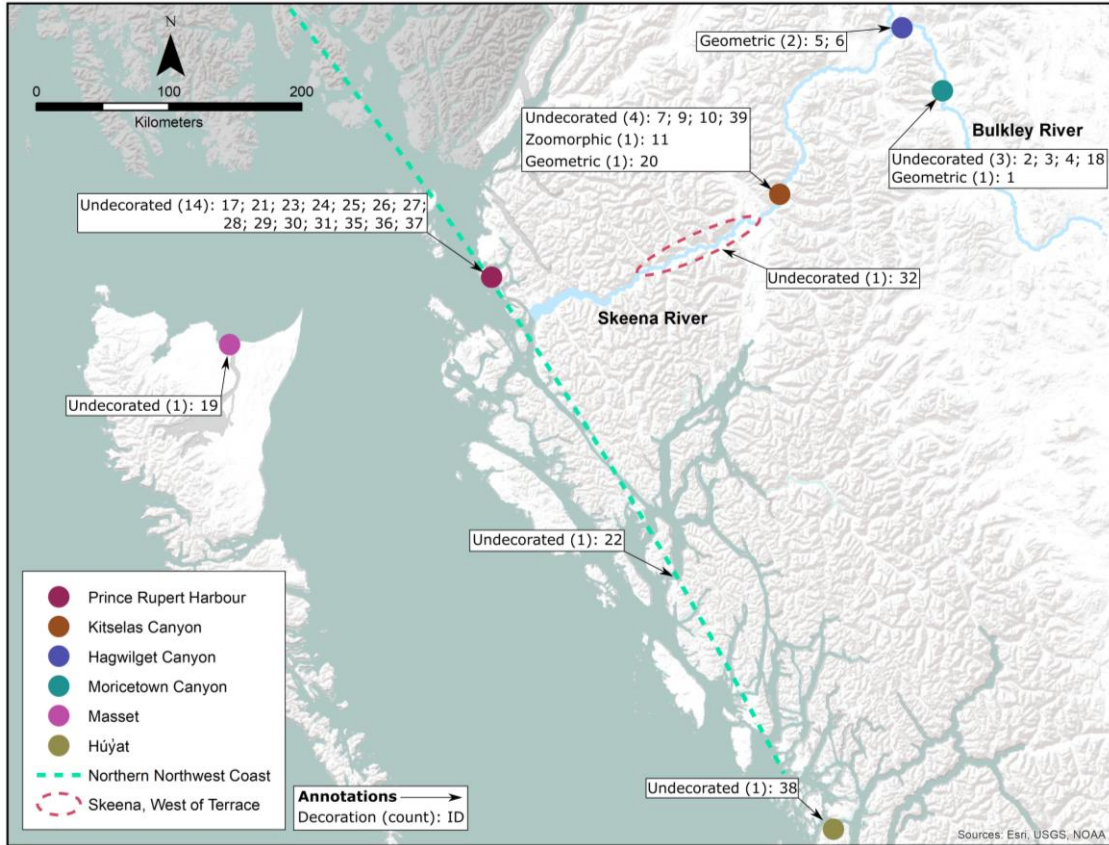

Figure 45. Spatial distribution of ribbed stones by decoration.

Of the ribbed stones that have dates attributed, all are undecorated except for one, ID 20, which has a geometric decoration. It comes from Kitselas Canyon and is dated to ca. AD 500 (Table 23). With such a limited understanding of the ages of these types nothing can be said about whether own developed from the other; undecorated ribbed stones may have been developed first with decorative incisions added later. However, based on these dates the reverse is just as likely, with decoration being lost in favour of an undecorated form.

Table 23. Date ranges of ribbed stones by decoration.

Decoration	Attributed Dates	ID
Undecorated	1500 BC-AD 1830	17
		21
		27
	1500–750 BC	39
	1000 BC-AD 1000	26
	AD 1	9
		23
		24
AD 500	7	
Geometric	AD 500	20

My observations of ribbed stone shape, groove location, and groove direction indicated that Prince Rupert Harbour is the location with the most variations of form. This is not the case regarding decoration. Geometric and zoomorphic decorations only appear inland at canyon sites on the Skeena and Bulkley Rivers.

5.2.6. Descriptive Types

In this section I examine the “descriptive types.” Each type has been given a letter from A to N to serve as a Type Code. When mapped (Figure 46), the variability of the ribbed stone artifact class is apparent. No site has more than two examples of the same type (e.g., IDs 29 and 37 from Prince Rupert Harbour are both Type B). In general, the more ribbed stones present at a location, the more variability in form there is.

Type A, the most common type (n=4), is present at sites across the geographic range of the artifact class. It is present at Moricetown Canyon, on the Skeena River, and at Prince Rupert Harbour. Other descriptive types are found at multiple locations include: Type B (Prince Rupert Harbour and Masset); Type C (Prince Rupert Harbour and Húyat); and Type F (Prince Rupert Harbour and Kitselas Canyon).

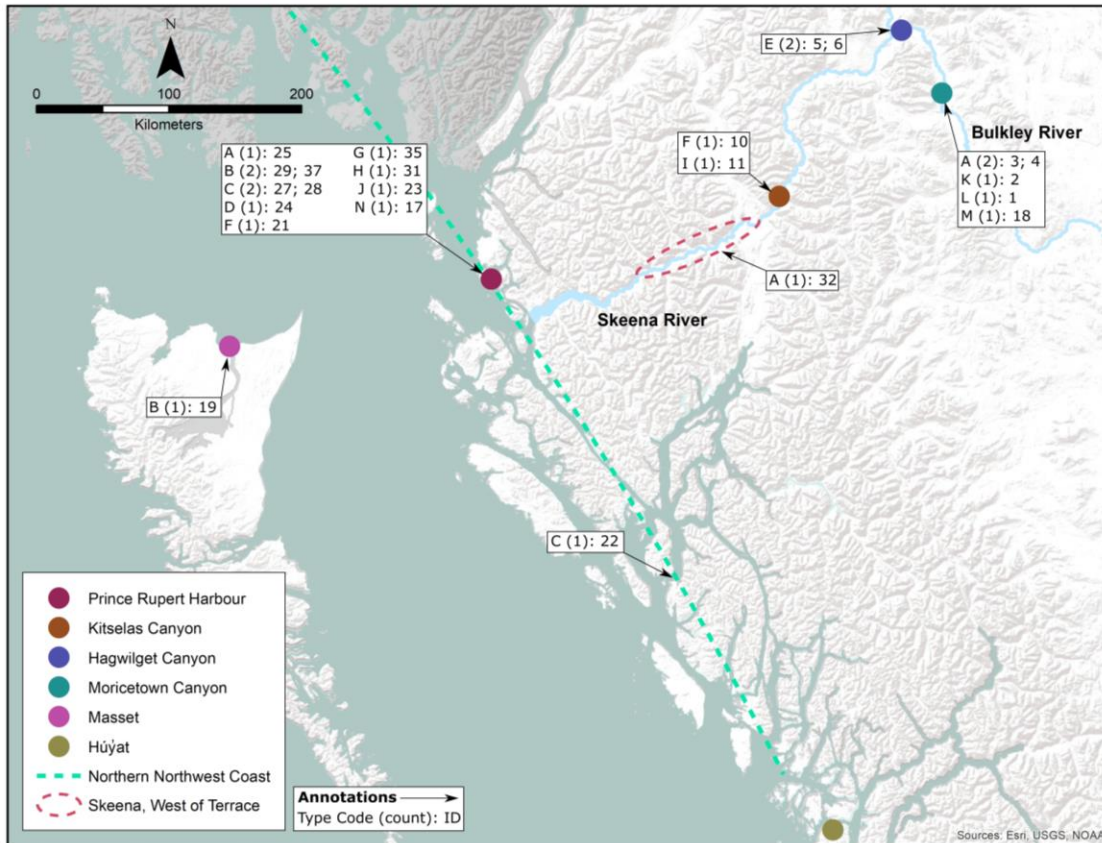

Figure 46. Spatial distribution of ribbed stones by descriptive types.

Only five of the ten ribbed stones with dates attributed were unbroken or had photos available that allowed all entries of the classification system to be completed. No type appears more than once on the timeline (Table 24) and no conclusions can be made about what types may have been in use earlier and what types may have been in use later. What can be said is that Type J (ID 23) and Type D (ID 24) likely were in use contemporaneously at Prince Rupert Harbour around AD 1.

Table 24. Date ranges of ribbed stones by descriptive types.

Type Code	Attributed Date	ID
C	1500 BC-AD 1830	27
F		21
N		17
D	AD 1	24
J		23

The number of descriptive types (n = 14) is a result of the many ways the attributes of ribbed stones have been combined. Ribbed stones come in four types of

shapes, with four different types of groove locations, two types of groove directions, two types of groove widths, and three types of decoration (or lack of decoration). The attributes have been combined in at least 14 different ways based on my observations of the artifacts described in this study. There are some regional differences in form (e.g., girdled stones occurring only at coastal sites). However, the amount of variation and distribution of different types across sites is, I believe, an indicator that these were individualized tools that the makers/users were crafting to suit their own needs and preferences.

5.3. Limitations of Classification by Form

Being able to describe and compare assemblages is a necessary starting point for archaeological research (Childe 1956:24-26, Deetz 1967: 9). An artifact classification system produced without any additional historical information can still function successfully as a tool for describing and comparing artifacts. However, there are limits to what can be achieved through classification by form alone. Primarily it is limited to identifying patterns across space and through time.

The morphological classification system I created has utility, but that utility is limited to identifying patterns in artifact form. This is an essential method of archaeological investigation as it relies only on material culture and does not require any additional data. However, as Deetz (1996:18) pointed out, such classifications can be supplemented with other types of historical knowledge (e.g., historical documents) and in doing so we improve our understanding of what artifacts are, what they mean, and how they are perceived.

5.4. Classification by Circles of Belonging

Artifacts can be classified in ways other than form (e.g., by function). I am proposing a classification system I refer to as circles of belonging (Figures 47-48), which is based on an Euler diagram⁶. It is a visual representation of the relationships of

⁶Euler diagrams “represent relationships between sets, including intersection, containment, and disjointness” (Chapman and Micallef 2012:v). Euler diagrams are used, “for visualizing categorized data, with applications including crime control, bioinformatics, classification systems and education” (Baimagambetov et al. 2018:39).

artifacts and how they might be organized based on attributes that are not related solely to form.

The circles are created by trying to answer the questions: to whom does this artifact belong?; where is the owner of the artifact from?; what is the identity of the owner, e.g., their gender, age, ethnicity, status (White 2008;1509)?; and how is this artifact used? These questions are represented by circles of person, place, identity, and activity. Figure 48 illustrates how the circles overlap and intersect, reflecting the relationship between objects, people, and the landscape. Classification by circles of belonging is an attempt to not only describe the artifact, but to describe the cultural context of the artifact both past and present.

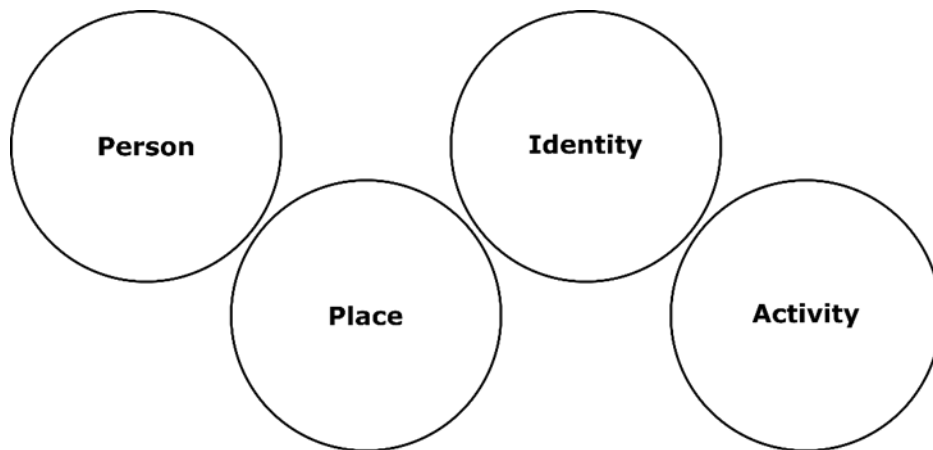

Figure 47. Circles of belonging.



Figure 48. The overlapping nature of circles of belonging.

In developing the concept of circles of belonging, I took inspiration and ideas from the works of many researchers (e.g., Smith 1999; Spector 1993; Wilson 2008). Circular representations of research methods appear in Wilson (2008:70) and Smith (1999:117) who suggest that “putting ideas in a circle or a wheel indicates that they are interrelated and that each blends into the next” (Wilson 2008:70) and as “represent[ing] movement, change, process, life, inward and outward flows of ideas, reflections and actions” (Smith 199:116). I found these concepts useful and necessary when I reflected on the limitations of classifying ribbed stones based on form.

Use of the term “belongings” was first introduced to me by Musqueam First Nation archaeologists during my work as a consulting archaeologist in cultural resource management. The use of the term to replace “artifacts” was put forward by Leona Sparrow and the word has seen some adoption by archaeologists working in Musqueam territory (Aviva Rathbone, pers. comm. 2020).

“Belongings” was used throughout the exhibit “*čəsnaʔəm: the city before the city,*” which was developed by Musqueam First Nation in collaboration with the Museum of Vancouver, the University of British Columbia’s Museum of Anthropology, and the University of Waterloo). Jordan Wilson, a Musqueam citizen, wrote, “Ultimately, our use of the term belongings has multiple intentions: it is a political expression, but aligns with our ways of knowing; it pertains to both the historic and the contemporary; and it connects the intangible with the tangible” (2016). I wanted to incorporate these concepts into a method of classification, and particularly that artifacts are both historical and contemporary in nature. Artifacts are objects that were used by people in the past as part of their culture; the present artifacts are used by people to understand the past.

The use of questions that relate to person, place, identity, and activity is drawn, in part, from feminist theory in archaeology. Most influential to me was Janet Spector’s, *What This Awl Means* (1993). In it she describes a relationship between a bone awl handle and the character Mazaokiyewin, the fictional person who once owned the awl. In Spector’s account, the artifact belongs to a *person* (represented in the story as Mazaokiyewin), a *place* (Inyan Ceyaka Atonwan), an *activity* (hide-working), and an *identity* (a young woman, a member of a family, and a member of a Dakota community). My reading of this work led me to develop the questions used in classification by circles

of belonging: to whom does this artifact belong?; where is the owner of the artifact from?; what is the identity of the owner?; and how is this artifact used?

In addition to a feminist perspective, Spector's work also includes concepts of materiality—expressed through the relationships between objects, people, and landscapes (Johnson 2010:225). These relationships are described by Lazzari (2005:125) as “a recursive relationship between people and things; a spiraling series of continual reflection, opposition, affirmation, similarity, and difference between the way people make things and the way things make people.” These spiraling relationships are represented in this classification system through the overlapping and interconnected nature of the circles of belonging. It is a visual way to group objects through their relationships between people, place, identity, and activity.

5.4.1. Interpreting Ribbed Stones by Circles of Belonging

The method by which classification by circles of belonging might be applied can be illustrated using a ribbed stone as an example— one from Moricetown Canyon (ID 3). Using my form-based classification scheme, this artifact can be described as a type A ribbed stone: an amorphous, 1-sided, perpendicular, single-width, undecorated ribbed stone.

How would that artifact be classified in terms of circles of belonging? The artifact is classified by circles of belonging by asking the following questions:

- 1) *To whom does this artifact belong?* Based on my research, I believe ribbed stones were likely individualized tools, made by the people who used them. It then would be appropriate to put a circle of belonging around ID 3 labeled “Individual.” This is an assumption made based on the seemingly large amount of variability observed in the form of ribbed stones.
- 2) *Where is the owner of this artifact from?* ID 3 was collected at an archaeological site in Moricetown Canyon, one of the most prominent places of cultural importance in the Wet'suwet'en landscape (Morin 2015). Wet'suwet'en history hold that Wet'suwet'en people have been living in the Bulkley Valley for “thousands of years and hundreds of generations” (Morin 2015:1). The archaeological site where the artifact was collected is an

ancestral Wet'suwet'en site and the individual who owned the artifact was most likely Wet'suwet'en. This is an assumption, based on Wet'suwet'en history, it is possible that historic polities do not extend into deep history. However, with no evidence to the contrary it would be appropriate to put a circle of belonging around the artifact labelled "Wet'suwet'en." This circle represents place (i.e., territory), but also people and identity.

- 3) *What is the identity of the owner?* In this case there little can be said other than the owner was likely Wet'suwet'en. Again, this is an assumption regarding the based on presumed continuity of historic polities.
- 4) *How is this artifact used?* There is some evidence to support at least what type of activity ribbed stones were used for. Many of the stones have been found locations where fish continue to be harvested to this day and Wet'suwet'en community members have described the stones as being used in the manufacture of fishing baskets (Budhwa and Hosgood 2016:114). If ribbed stones are part of the activity of fishing and so it would be appropriate to place a circle of belonging labelled "Fishing" around ID 3. This too is an assumption; the specific function or ribbed stones is unknown. The choice to create a circle representing fishing was made based on the location of this artifact (a current fishing site) and because many of the proposed functions involve fishing in some way (either utilitarian or ceremonial).

Taken together, ID 3 — rather than being described as a Type A ribbed stone — could also be viewed as part of an individual Wet'suwet'en person's fishing toolkit (Figure 49). Neither description is inherently better than the other; rather they provide complementary perspectives. The context of the culture and the landscape from which an artifact came encodes this type of information onto the artifact and it is "the archaeologist's task to decode those messages and apply them to our understanding of the human experience" (Deetz 1996:4).

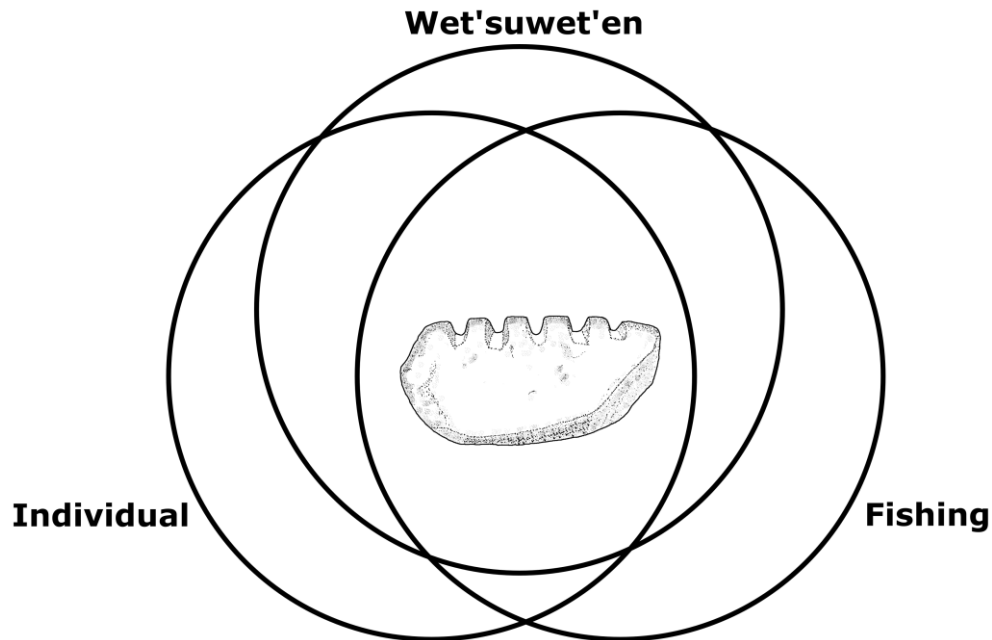

Figure 49 The classification of a ribbed stone (ID 3) by circles of belonging.

Classification by form is an essential process for the archaeologist working with the material culture alone. The archaeologist can then supplement what they have learned with additional historical information (e.g., traditional knowledge). Classification by circles of belonging is a separate process that can be used to incorporate traditional knowledge into the classification system from the outset, garnering different insights that can help to inform our understanding of the human experience.

Circles of belonging can be used to visualize shared and nested attributes when direct associations with people or place might not as clear as they are at Moricetown. For example, ID 6 was found at Hagwilget, a shared Gitxsan and Wet'suwet'en village. At this locations the relationship between these two communities is a long standing one based on important shared historical events (Cassidy 2015; Hoffman and Joseph 2019:83). Additionally, it is not uncommon for members of the current community to have shared ancestry and a relationship between the two communities does extend well into the past (Morin 2016:13-14).

Two circles could be drawn around the artifact, one "Gitxsan" and one "Wet'suwet'en." Within each of these circles is a nested circle representing the specific place within the traditional territories; a "Hagwilget" circle of belonging and a "Tsë Cahk" circle of belonging (referring to their respective names for this locale). In the case of ID

6, these circles can be represented as conjoined as they represent the same place on the landscape and nested, as it is only one place within a larger territory (Figure 50).

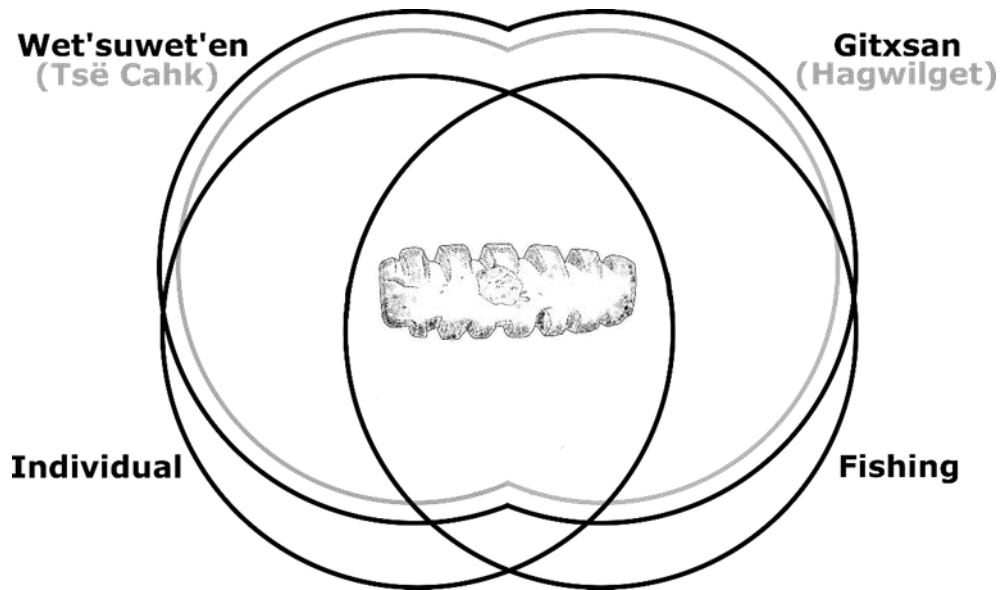

Figure 50. Visualizing shared and nested attributes with circles of belonging.

One of the reasons why archaeologists employ classification is that it facilitates comparison. This can also be done using circles of belonging. Circles can be coded (e.g., by colour) and be compared from one artifact to another. In the example below two ribbed stones (ID 18 and 39) are compared side by side (Figure 51). ID 18 comes from Moricetown on the Bulkley River and ID 39 is from Kitselas on the Skeena, represented by different coloured circles. However, both come from sites in canyons used as fishing stations in the Skeena River watershed and share circles of the same colour. Artifacts that share many of the same circles could be thought of as similar even if they vary in shape or material or are used for very different purposes. Groupings created by shared circles could be likened to an artifact type.

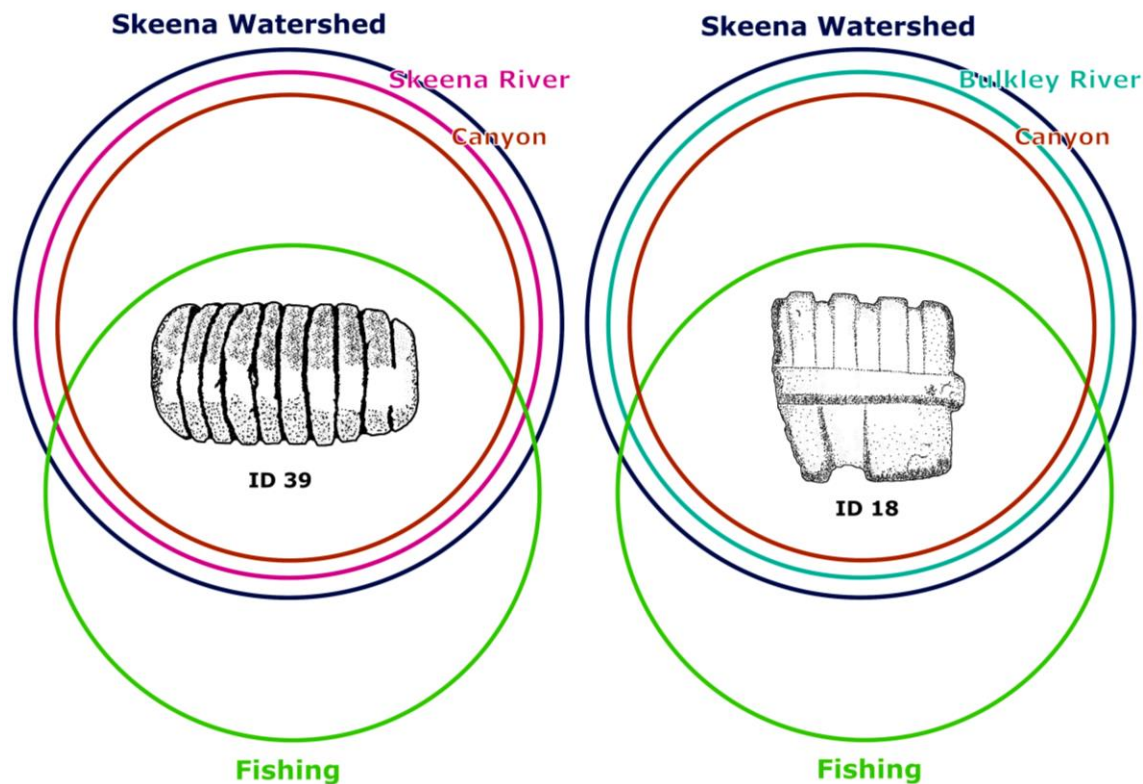
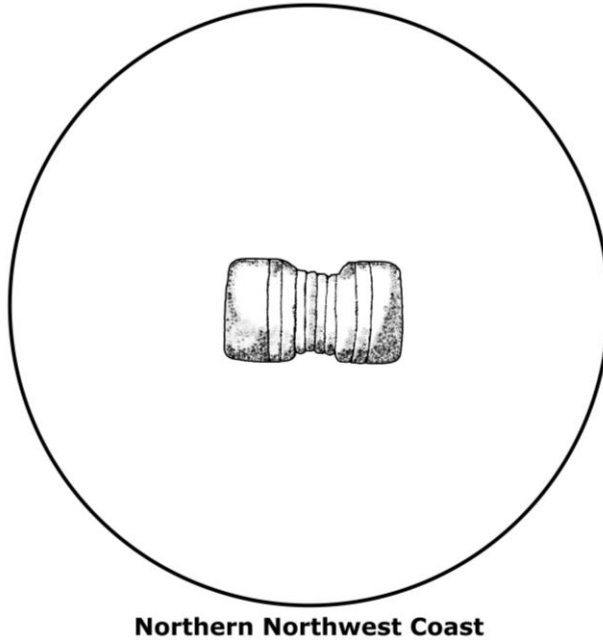

Figure 51. Colour coded circles showing shared attributes of two ribbed stones.

5.4.2. Limitations of Circles of Belonging

As with any classification system there are limits to the usefulness of circles of belonging. This system depends, to a large extent, on contextual information such as site location, association with other artifacts, and historical knowledge – whether it be from community knowledge holders, oral traditions, ethnographic accounts, or historical texts. The limits of circles of belonging can be demonstrated using another ribbed stone as an example (ID 22). The only locational information for ID 22 is that it came from the Northern Northwest Coast. In the absence of additional information, a circle representing place, labelled “Northern Northwest Coast”, is likely the only circle that could be drawn (Figure 52). This would be a circle shared by a large number of artifacts, not just ribbed stones, but all artifact classes from this region. While this still indicates a relationship between these artifacts and the people that made them, it provides little else in terms of understanding what those relationships mean.



Northern Northwest Coast

Figure 52. ID 22 represented in the absence of contextual information.

5.5. Chapter Summary

In this chapter I discussed the purpose of my ribbed stone classification system. I demonstrated the utility of the system by examining two typologies. First, by taking a lumped approach, looking only at one attribute at a time. Second, using a split approach where types were formed based on all attributes taken together.

The lumped typology demonstrated that some ribbed stone attributes are limited to a specific region. In general, there are differences between coastal sites at Prince Rupert Harbour and inland sites on the Skeena and Bulkley Rivers. The split typology based on “descriptive types” revealed that ribbed stones are highly variable. One explanation for this could be that ribbed stones are an individualized tool; that these artifacts were created by individuals for their own use based on their own needs or preference

No changes in the form of ribbed stones were observed over time. This is mostly due to there being only ten ribbed stones with dates or date ranges attributed; in the case of IDs 17, 21, and 27, the date range is very large (i.e., 1500 BC–AD 1830).

In response to some of the limitations of classification by form I introduced a classification system that I refer to as “circles of belonging.” This system was designed using concepts from Indigenous research methods, works of feminist archaeology, and materiality. It is intended to incorporate other forms of historical knowledge (e.g., traditional knowledge) into artifact classification from the outset, rather than as a supplement.

Chapter 6. The Function Question

Determining the function of ribbed stones was not an explicit goal of my research. However, I encountered references to different functions during different stages of data collection. In this chapter I provide a compilation of information regarding function, provide my own interpretation, and make recommendations for further research.

6.1. Interpreting Ribbed Stone Function

In Chapter 1, I briefly introduced the five interpretations proposed for ribbed stones. These are: 1) as art; 2) as ceremonial objects; 3) as fibre combs (for cedar bark or bow string scrapers); 4) as bark beaters; and 5) as measuring devices. In my research I observed that there is some evidence to support the use of ribbed stones as fibre combs and measuring devices. It is my position that ribbed stones were most likely used as a multipurpose tool, for making measurements and processing fibres, in the production of fishing equipment, specifically for fishing nets and fishing baskets. In the case of ribbed stones found at Kitselas Canyon these artifacts may have been used by women in yearly net making.

I used four lines of evidence to support my position of ribbed stones being used in the production of fishing equipment: 1) information provided by both archaeologists and by Gitksan and Wet'suwet'en community members; 2) the various forms of ribbed stones; 3) repository catalog entries; and 4) ethnographic information.

6.1.1. Information from Knowledgeable Individuals

Not all information on ribbed stone function is available through publications as much of it is speculative. MacDonald (1983:114) wrote that "their association with fish ceremonies is strongly implied," but provided little explanation in the text as to why that may be, though he certainly had reasons for saying so. Insights from discussions with knowledgeable individuals can provide more information beyond what was published and inform future research questions. While collecting data on ribbed stones I had the opportunity to talk to two community members at Hagwilget and at Moricetown, and six

archaeologists who were either familiar with ribbed stones or the archaeology of Prince Rupert Harbour and the Skeena River.

Gitxsan and Wet'suwet'en Insights

On the recommendation of Rick Budhwa, I had the opportunity to speak with two community members: Willie Pete and Jessie Stoeppler, while visiting archaeological sites at Moricetown and Hagwilget, respectively. The major geographic features at both locations are canyons along the Bulkley River that are part of the salmon fishery Gitxsan and Wet'suwet'en communities have maintained for generations. The information that Willie Pete and Jesse Stoeppler have of their traditional territories is an important and perhaps unique complement to what can be learned through the archaeological record alone and I am very grateful to have had the opportunity to speak with them both.

The information provided by Willie Pete and Jessie Stoeppler was, in both cases, second-hand information which they had learned from other community members. The information somewhat speculative and is not necessarily representative of the knowledge held by the larger Gitxsan and Wet'suwet'en communities. Within those communities there are more interpretations of the function of ribbed stones (Rick Budhwa pers. Comm. 2021). These are only the interpretations that were presented to me by two community members. Ethnographic research, including additional interviews to obtain and synthesize the total number of community interpretations was beyond the scope of my research, but would help to guide future research questions.

My discussion with Jesse Stoeppler centered around an interpretation that came from *Gisdewe* [Alfred Joseph], and had been previously been recorded by Rick Budhwa. Following the archaeological excavations at Hagwilget, *Gisdewe* [Alfred Joseph] “explained how the ridged tools were used to smooth out strands of cedar bark used for ropes, fishing nets, and fishing baskets. The grooves acted as a comb to separate several strands at once” (Budhwa and Hosgood 2016:114). Willie Pete at Moricetown told me that his understanding of ribbed stone, which had been described to him by Peter David, was that they could have been used as measuring devices for setting the size of fishing nets. Neither interpretation contradicts the other, and ribbed stones may have been used for both purposes in the production of fishing gear, i.e., this is a multi-purpose tool.

Willie Pete, Wet'suwet'en

Willie Pete and I discussed ribbed stones on June 4, 2019, while at Moricetown Canyon. He is Wet'suwet'en from *Cas Yikh* [Grizzly House] of *Gidimt'en* [Bear/Wolf Clan], and lives at Moricetown. Mr. Pete has been fishing the canyon for 40 years. He also works on cultural resource management projects in his home territory and was involved in the 2012 and 2017 excavations at Moricetown where ribbed stones were collected.

In discussing ribbed stones, Mr. Pete shared what was told to him by Wet'suwet'en elder Peter David, which was that these artifacts could have been used as measuring devices. Mr. Pete explained that size selection is an important part of the management of the fishery at Moricetown Canyon. Fish are harvested from the canyon by gaff and dipnet, but also by basket traps (Figure 53) and gill nets. Both basket traps and gill nets can be used to select for fish size and a measuring device could be used to set the size of the weave of the net or opening of the basket trap.

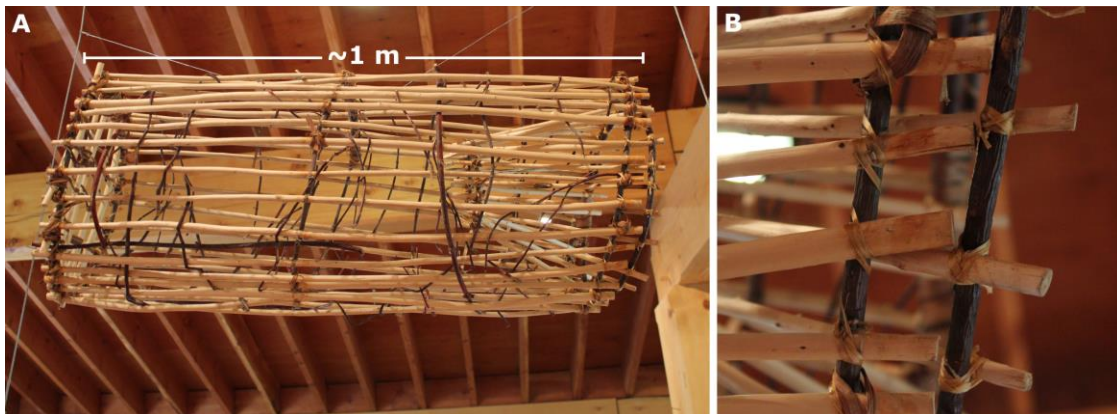

Figure 53. A replica basket trap from Widzin Kwah Canyon House Museum at Moricetown: A) basket trap replica; B) close-up view of the cedar bark lashing at the mouth of the basket trap. (Walter Homewood photo).

Mr. Pete noted that the fishery at Moricetown Canyon involves much more than just the harvesting of salmon. It was necessary each year to prepare, replace, or maintain gear. In addition to one's fishing gear, the canyon itself requires care; logs become trapped in the narrows and must be cleared, or they would impede the progress of the salmon.

Jesse Stoepler, Gitxsan

Jesse Stoepler and I met in Hagwilget Canyon to discuss ribbed stones on June 7, 2019. He is Gitxsan from the Wolf Clan, House of *Spookxw*. We discussed the two ribbed stones that were collected at Hagwilget Canyon from a terrace on the east side of the river. This turned the conversation to the remarks Alfred Joseph had made about ribbed stones in 2014.

The terrace is across the street from the house of the late Alfred Joseph, who passed away in 2014 at the age of 86. He had held the name *Gisdewe*, House Chief for *Këyikh Winiits* ["House in the Middle of Many"]. In 2004, excavations for the replacement of hydro poles disturbed burials that were on the terrace and displaced ancestral remains. This resulted in the community of Hagwilget and Crossroads CRM conducting archaeological excavations to recover the ancestral remains for reburial. Two ribbed stones were collected as part of those excavations. When asked about the ribbed stones, *Gisdewe* identified them as fibre combs used for the preparing of cordage for fishing nets and baskets (Budhwa and Hosgood 2016:114).

Archaeological Insights

I also sought information on ribbed stones through discussions with six archaeologists: George MacDonald, Roy Carlson, Morley Eldridge, Grant Keddie, Susan Marsden, and Andrew Martindale. Perhaps not surprisingly, this section emphasizes the work and ideas of the late George MacDonald, who by all accounts had spent the most time considering what ribbed stones were and where they came from. Indeed, most of the other archaeologists I spoke with referred me to his work. The largest single collection of ribbed stones is housed at the Canadian Museum of History, with many of them on display in "The Dig," an exhibit that MacDonald designed (Canadian Museum of History 2020a).

George MacDonald, former director, Canadian Museum of History

George MacDonald and I discussed ribbed stones in a phone call on August 16, 2019. We began with his ideas about ribbed stones being developed from incised zoomorphic concretions, an idea that he had published on in 1983. MacDonald expanded on his ideas about the use of skeletal imagery in pictographs at Kitselas canyon; both ribbed stones and the pictographs share a ribbed pattern. Here he made a

stronger connection between the two than in his “Prehistoric Art of the Northern Northwest Coast” article (1983) in which he mentioned both the ribbed stones and the pictographs.

MacDonald went on to describe the importance of polysemic imagery in Northwest Coast artistic traditions, which refers to an object or an image having multiple levels of meaning. He mentioned that ribbed stones might be used as part of a shamanistic toolkit and described some of his work on slate mirrors in Tsimshian territory (MacDonald et al. 1989), noting that it might be possible to identify a similar ethnographic analogy for ribbed stones, though MacDonald did not expand on what that analogy might be or how it might be applied. Although not mentioned in our discussion, the ribbed stones in the display that he designed at the Canadian Museum of History bear the label “used by shamans in first salmon ceremonies” (Canadian Museum of History 2020a).

I asked MacDonald if ribbed stones could have been used as tools for processing cedar bark or as measuring devices. He said that was certainly a possibility and we discussed some of the other hypotheses surrounding use. I asked about *Gisdewe*’s description of use as fibre combs used to process cedar bark at Hagwilget; MacDonald said that this was an explanation he had considered as well. However, he felt it more likely that if ribbed stones were used as fibre combs, it was for preparing stinging nettle fibres, as opposed to cedar; stinging nettle being a material used in fishing nets on the Skeena River and a tough material that requires processing to turn it into cordage. MacDonald suggested use-wear analysis and residue analysis as ways of testing this hypothesis. As for use as a measuring device, he said it was also possible though this was not something he had pursued himself.

MacDonald ended our conversation by putting forward a question that he felt was most important to understanding what ribbed stones were or what they could have been used for— Why are ribbed stones clustered in Tsimshian territory, but are uncommon or nonexistent elsewhere along the Northwest Coast? He stated that in Tsimshian territory they were quite common, that he had seen many ribbed stones on the beaches in Prince Rupert Harbour. I was surprised by this and asked why I had located so few in repositories. MacDonald said that the ribbed stones he had seen on the surface of beaches went uncollected and thus, for the most part, unrecorded.

Roy Carlson, Simon Fraser University

Roy Carlson and I spoke only briefly about ribbed stones on September 12, 2019. He was familiar with ribbed stones as a Northwest Coast artifact, but had no thoughts of his own as to their function. I mentioned the possible use of ribbed stones as fibre combs for cedar bark and George MacDonald's suggestion that they might be used for stinging nettle. Carlson encouraged me to pursue the idea of them being used as fibre combs for processing stinging nettle as the plant has a tough outer layer that needs to be stripped away before it can be made into twine.

Morley Eldridge, Millennia Research Ltd.

Morley Eldridge and I discussed ribbed stones through an email exchange that focused on the three ribbed stones collected during excavations conducted by Millennia Research in Prince Rupert Harbour (Millennia Research 2014). In the artifact descriptions included in the excavation report, Eldridge discussed some of the history of the ribbed stone artifact class. In terms of possible function, we discussed George MacDonald's ideas of ribbed stones being descended from incised concretions and Ken Ames' (2005:168) suggestion that ribbed stones served as bark beaters. Eldridge stated that Ames's hypothesis was based on ribbed stones having a somewhat similar form to bone bark beaters from the Northwest Coast, which also have incised grooves, but thought that sandstone (of which most ribbed stones are made) would be too fragile for a pounding tool. Eldridge also mentioned that George MacDonald always had "fabulous ideas," but sometimes lacked specific data to back it up, though he often proved to be correct when more data became available.

Grant Keddie, Royal BC Museum

I met with Grant Keddie on March 5, 2020, when I visited the Royal BC Museum to examine the four ribbed stones held there. We talked about some of George MacDonald's ideas and Keddie said that MacDonald's ideas were often well thought out and could likely prove to be correct, but that the necessary supporting data were not always there. I mentioned the possible use of ribbed stones as some sort of fibre comb for preparing either cedar bark or stinging nettle. Keddie pointed me to an entry in the Royal BC Museum catalogue (referring to ID 29), which identified the artifact as a bow string scraper for a ribbed stone that came from Prince Rupert Harbour. Unfortunately, no source information was available for this identification. Keddie and I briefly discussed

attributing dates to ribbed stones and I mentioned that the published date ranges for the artifact class are quite broad. He suggested that identifying an earliest known date for the appearance of ribbed stones in the archaeological record would be a useful contribution that my research could make.

Susan Marsden, Museum of Northern BC

Susan Marsden and I spoke in the phone in June 2019 and then in person in March 2020 when I visited the Museum of Northern BC to view the ribbed stones in the Museum's collections. We talked about George MacDonald's work and some of his ideas around ribbed stones. Marsden spoke highly of MacDonald for his insightful assumptions about the functions of certain tools and domestic pieces found in Northwest Coast archaeological sites and added that these assumptions are worthy of further research. Marsden's hypothesis concerning ribbed stones is that they are possibly net gauges used for fishing and duck hunting nets.

Andrew Martindale, University of British Columbia

Andrew Martindale and I discussed ribbed stones in an email exchange. I reached out to him because of his work on archaeological sites in the areas where ribbed stones have been found. In our email exchange, Martindale brought up George MacDonald's ideas that ribbed stones are a zoomorphic representation and stated that they do have a resemblance to the X-ray style petroglyphs at Kitselas Canyon. Commenting on the possible use of ribbed stones as measuring devices, Martindale mentioned that it would be a reasonable guess as mesh size is pretty critical for fishing and that the Tsimshian clearly had a unit of distance and attention to standards. He illustrated this by noting that all of the house posts he had excavated in Tsimshian territory were 56 cm in diameter (i.e., a standard size). Andrew suggested use-wear analysis as a means to test possible functions but did not rule out a symbolic or sacred meaning, referring me to Jay Miller's (1997) ethnography of Tsimshian culture, in which Miller recorded oral histories concerning how the shape of "quartzite pencils" became sacred and symbolic, though slate pencils themselves have an unknown purpose. I pursued this line of inquiry which led me to Boas' (1916) ethnographic descriptions of the first salmon ceremony at Kitselas Canyon (see section 6.1.4. below), but I was unable to identify an analogous artifact type such as the "quartzite pencils."

6.1.2. Artifact Form

The form of ribbed stones suggests the use of these artifacts as fibre combs. Ribbed stones share many characteristics of form with abraders; both have deeply incised grooves and are most commonly made of sandstone or similar material. The size of ribbed stones (between 32 to 146 mm in length) makes them well suited for hand-held use. The groove direction of ribbed stones is overwhelmingly perpendicular to the length, having a similar appearance to that of a comb. Grooves on the same ribbed stone sometimes come in different sizes, lending itself to processing more than one size or type of material.

Ribbed stones are possibly a specialised abrader used specifically for processing natural fibres. Both the processing of stinging nettle and of cedar bark requires some type of abrasive material. Stem fibres from stinging nettle are extracted by splitting and scraping the stems (Turner 1998:40). Cedar bark needs to be “shredded” as part of the process of creating usable fibres (Stewart 1996:62; Turner 1998:78). Traditionally, artifacts described by Northwest Coast archaeologists as bark shredders are crescent-shaped stones with a carved handle at one end, opposite to the end which comes in contact with the bark (Stewart 1996:62-63). Ribbed stones are distinct in form from what are traditionally referred to as “bark shredders.” However, the same outcome could be achieved using a ribbed stone as an abrader, with the bark passing through the grooves. It may be that ribbed stones were developed in Prince Rupert Harbour or the Skeena and Bulkley River watersheds as a multi-purpose tool used in the processing of natural fibres to make gear for the salmon fisheries of this area.

Ribbed stones share a similarity of form to wooden artifacts that have been found at medieval archaeological sites in Novgorod, Russia. Sometimes referred to as “toothed blades” (Sherman 2015; 2016) the artifacts are described as being “heckles” (sometimes spelt “hackles”) which are “knife-like” in shape, 30 to 50 cm long and have “teeth” along one or two sides of the artifact (Kublo 2007:136-141). Heckles are used for processing flax and hemp; plants that have a stiff outer layer that must be broken and combed away to reveal the inner fibres (Kublo 2007:137). Of these heckles it was also noted that “the heckles were of two types: thin ones with fine teeth close together and much more solid ones with large widely-spaced teeth” (Kublo 2007:137); another similarity to the form of ribbed stones.

The form of ribbed stones also suggests the use of these artifacts as measuring devices. However, this is speculative. Measuring devices (e.g., rulers, tape measures) all share the defining characteristic of having graduations (i.e., marks indicating a degree of quantity). The defining characteristic of ribbed stones (i.e., the pattern of ribs and grooves) resembles that of a measuring device. There is a wide range of variability in the ribbed stone artifact class and it does not appear that the pattern of ribs and grooves is standardized. This does not exclude use as a measuring device. Ribbed stones could be used as an individualized measuring device, where each individual has created their own unit of measure.

6.1.3. Repository Catalogs

Two notations in repository catalogues reference the function of ribbed stones. The first is from the Canadian Museum of History. In reference to ID 23, the description provided is, “basketry gauge,” suggesting that at some time the artifact was understood to be a measuring device used in the making of baskets. It is possible that these were fishing baskets, but this cannot be confirmed as there is no additional information available on where this interpretation came from.

In the repository catalogue of the Royal BC Museum, ID 29 is described as a “bow string scraper,” suggesting that the artifact was used to “scrape” a fibrous material of some kind. The use of a ribbed stone as a bow string scraper is functionally similar to how a ribbed stone could be used as a fibre comb for making cordage for nets and baskets; a fibrous material making up a string being pulled through the grooves of an artifact made of an abrasive material. Again, there is no source information available for how this description came to be in the museum catalogue.

6.1.4. Boas’ Ethnography

Franz Boas’ (1916) ethnography from Kitselas gives an account of the first salmon ceremony. This includes mentions of activities that are occurring at the same time as the salmon ceremony. Boas (1916:449) records that,

During the first salmon-run a great many taboos seem to have been enforced. The whole tribe is instructed to keep taboos until the spring salmon stop running. Old women are ordered to work on salmon nets, but

no young woman is allowed to touch the twine. The old men are ordered to make new poles for bag nets, and they are expected to fast during this time.

If ribbed stones were being used in the production of fishing nets at Kitselas, then it is possible that these artifacts were being used by women, as women are, in particular older women, are the people Boas (1916) describes as being responsible for that work.

Kitselas is the territory of Kitselas First Nation. As described to me by Willie Pete at Moricetown, the yearly production and maintenance of fishing gear is also a part of the Wet'suwet'en salmon fishery. However, in the Wet'suwet'en history book *Niwhts'ide'ní Hibi'it'ën: The Ways of Our Ancestors* (Morin 2016), there are accounts from men and women regarding the production and maintenance of fishing gear (Morin 2016:92-98). The gendered separation of labour in the production of fishing gear may be unique to Kitselas.

Based on the information provided by Gitksan and Wet'suwet'en community members, the form of ribbed stones, and notations made in repository catalogues the most likely use of ribbed stones was as a fibre comb and measuring device for processing materials and manufacturing fishing gear. In the case of those ribbed stones found at Kitselas Canyon, Boas (1916) provides an ethnographic account that suggests these artifacts, if used in the making of fishing nets, could have been used by women.

While the information compiled above points to a utilitarian function of manufacturing fishing gear, it does not rule out a ceremonial function. As described to me by Willie Pete, the preparation of oneself, one's tools, and in the case of Moricetown Canyon the preparation of the fishing site has a ceremonial component. In addition, Boas (1916) recorded his account of the making of fishing nets as part of activities occurring alongside the first salmon ceremony. Ribbed stones may not need to be classified as strictly utilitarian or strictly ceremonial as this distinction may not have been one made by the original users of the artifacts.

6.2. Recommendations for Future Work on Function

The outstanding question regarding ribbed stones is their function, a topic that was not directly addressed in this study. As noted, a variety of functions have been proposed. Identifying the function(s) of ribbed stones will require some form of

experimental archaeology, use-wear analysis, and/or residue analysis. For example, if ribbed stones were used as fibre combs, this may be evidenced by use-wear patterns or plant residue. Likewise, if used as measuring devices, form of ribbed stones may provide evidence for use as a measuring device, degree of regularity in ribs, between and within each artifact, should be investigated. I briefly outline how each of these hypotheses can be tested.

6.2.1. Use as Fibre Combs

Use-wear analysis is based on comparing observations made on artifacts to experimental data sets produced under controlled conditions with reproducible results (Fullagar 2006; Hayden 1979; Richards 1988). In this case, an experiment would need to be devised to create replica ribbed stones by processing a variety of different fibres (e.g., cedar bark or stinging nettle). Patterns on the replicas may resemble patterns on the artifacts—indicating similar use (Fullagar 2006:209-210). There may be confounding variables that would be difficult to address through this method. Sandstone, the most common material type, is a relatively soft sedimentary rock that might not exhibit any reproducible wear pattern even in a controlled experiment.

Studies of residue analysis of lithic tools from archaeological sites have revealed that plant materials can be identified on the surface of artifacts through microscopic or biochemical analyzes (Fullagar 2006:216). Residues from proteins, starches, phytoliths, resins, etc. are diagnostic of plant taxa and it is inferred that these remains represent the material that was processed by the tool (Esau 1965; Fullagar 1993). Conducting such a study of ribbed stones would require that they have never been washed. Of the 31 ribbed stones that I examined in my research, only six, those currently held by Crossroads CRM and the Bulkley Valley Museum, are known to be unwashed. Any ribbed stones that come from controlled excavations in the future should remain unwashed until residue analysis can be conducted.

6.2.2. Use as a Measuring Device

Possible use as a measuring device could be tested statistically. Metrology, the study of measurement, has been part of archaeology since the late 19th century. If used as measuring devices, ribbed stones would be made up into units of equal size.

However, units can be “conventionalized” or “nonconventionalized” (Morley 2010:10). Conventionalized units are standardized and agreed upon by a group. Conventionalized units can be discerned statistically because objects made using the standardized unit will usually consist of multiple whole numbers of that unit, resulting in an identifiable pattern of regularity (Clark 2010; Petrie 1877:9; Urton 2010). If ribbed stones represent a conventionalized system of measurement, then the regularity of the spacing between the ribs and the grooves, across the artifact class, could be tested using a nearest neighbour analysis—a procedure used to determine whether the spatial arrangement of a pattern of points is uniform or random (McGrew et al 2014:210-216).

Measurements made by anthropic comparison (e.g., using the width of fingers) are considered nonconventionalized units of measure (Morley 2010:10). Such units would not be discernable by the method of comparing ratios that Petrie (1877) used. If ribbed stones were an individualized measuring device, then they would also be made of nonconventionalized units. In this case, regularity might be observed on an individual ribbed stone, but not across the artifact class. In this case all that could be said is that a particular artifact exhibits characteristics which are consistent with those of a measuring device. Statistically testing the regularity of the spacing of the ribs and grooves of ribbed stones should also be conducted, at least to determine if the spacing of the ribs and grooves is truly regular.

6.3. Chapter Summary

Five interpretations of ribbed stone function have been presented in this thesis. Four of these interpretations relate to fish in some way and none of these interpretations were outright dismissed by the individuals I had discussions with. Two (fibre combs and measuring devices) reference the making of other artifacts that could be used for fishing (making nets or basket traps). Two others (art and ceremonial objects) describe ribbed stones being stylistic depictions of fish skeletons. Use as bark beaters was the only interpretation suggested to be unlikely, as the artifacts are made of relatively brittle material.

In my research I was able to speak with two Gitksan and Wet’suwet’en community members, who provided two interpretations. It has been remarked that more interpretations have been put forward by other community members (Rick Budhwa pers.

comm. 2021). A synthesis of all community interpretations regarding function is warranted.

My interpretation of ribbed stone function is that they may have been a multi-purpose tool, used for processing fibres and as a measuring device in the manufacture of fishing nets and basket traps. Experimental archaeology should be the next steps in the research of ribbed stone function. This should take the form of use-wear analysis and residue analysis.

Finally, the regularity of the spacing of the ribs and grooves can be tested statistically to determine the degree of uniformity. If results show the spacing is regular, then there is at least the opportunity to continue pursuing the question of use a measuring device.

Chapter 7. Conclusions

At the start of this thesis I introduced my research question—what are ribbed stones and what are the attributes of their form? My research had two goals: 1) to collect the disparate information on this artifact class; and 2) to create a ribbed stone classification system that researchers can employ in subsequent analyses.

Ribbed stones are ground stone artifacts found primarily at archaeological sites in Prince Rupert Harbour and canyons along the Skeena and Bulkley Rivers. Most commonly made of sandstone, all have deeply incised grooves that extend across at least one face of the artifact, creating a characteristic ribbed pattern of raised bands.

Although they have been referred to by many names (i.e., “segmented stones,” “segmented tablets;” “notched stones;” “les ornements à entailles” [“notched ornaments”]), ribbed stone best describes the form of the artifact and avoids conflation with other artifact classes. Consistent naming and description will be essential to identifying more examples of ribbed stones from archaeological sites and in collections. A larger sample size will be needed before more inferences about use, development, and geographic distribution can be made.

The history of the archaeology of ribbed stones demonstrates some of the difficulty when working with material culture that has an unknown purpose and a small number of artifacts. A variety of names are applied and an array of functions are proposed. These issues compound over time and later become challenges to future researchers and repositories. Collections are more difficult to search when inconsistent descriptors are used. Museum displays sometimes list artifact functions that may have been only suggested.

My ribbed stone classification system includes a list of defined terms that can be used to describe these artifacts. This standardized language is a benefit that will aid in recording, reporting, and cataloging. These terms were developed based on observations of the artifact class and are intended to accurately communicate the form of ribbed stones.

I have arranged my classification system as a series of entries, each describing a single, isolated attribute. These attributes can be used to sort ribbed stones into

groups—a typology. The system does not result in a single typology, but functions as a means for researchers create one suitable to their needs by following a prescribed series of steps.

The flexibility of the classification system was an intended feature. It was based on a polythetic, divisive, disassociated approach. Beginning with all ribbed stones as a single group, the artifacts can be split into types with shared attributes. No attribute depends upon another, nor is any inherently more important. In this way the resultant typology can be tailored to only consider the characteristics which pertain to a particular research question (e.g., are there regional differences in ribbed stone shape?).

Examples of different typologies were presented in my discussion as a demonstration of the classification systems utility. This revealed some patterns in the spatial distributions of different forms. Notably, girdled and bidirectional ribbed stones are limited to coastal sites, mostly in Prince Rupert Harbour. Geometric and zoomorphic designs are only present on artifacts that came from inland sites at Kitselas, Hagwilget, and Moricetown canyons.

When accounting for all attributes the sample size of 31 ribbed stones splits into a maximum number of 14 types. I refer to these as “descriptive types” because the combined terms provide an overall description of the form of the artifact. The relatively large number of types is a reflection of the variability of the artifact class. However, I do recognize that all types are artificial creations of the archaeologist.

While collecting data for my research I had the opportunity to visit archaeological sites where ribbed stones have been found and talk about these artifacts with two community members. Our discussions centered less on the artifacts and more on the places they came from and the activities carried out there. I struggled to incorporate this information into a morphological classification system. Instead, I designed a second, more general classification system that I refer to as “circles of belonging.” The design of circles of belonging of circles of belonging was influenced by several sources. Concepts were taken from works outlining Indigenous research methodologies, feminist approaches to archaeology, and materiality. I also drew on ideas taught to me during my work as a consulting archaeologist in CRM.

Circles of belonging is not meant as a replacement for morphological classification, nor is it a supplement. Rather, it is intended to be its own separate system that can be applied to any artifacts and is capable of directly incorporating contextual information, including traditional forms of historical knowledge provided by ancestral communities.

In the sections below I provide some recommendations on the use of the ribbed stone classification system and circles of belonging. I include remarks on how I think these classification systems may develop with future use.

7.1. Use of the Ribbed Stone Classification System

Included with this thesis (Appendix C) is a guide to ribbed stone typology, i.e., how typologies can be built using the entries of the classification system. Although the classification system is meant to be flexible, in that ribbed stones can be grouped in different ways, those groups should be reproducible provided that the attributes are recorded following the definitions. In this way many different attribute associations can be examined, following a set of rules for creating types.

In the design of the classification system emphasis was placed on creating standardized language, rather than a single typology, because of the small sample size (n=31). Comments made by other researchers indicated that the number of ribbed stones in collections (private and public) or as unrecorded surface finds may be much larger than 31.

It would have been possible to develop a single typology for only the ribbed stones examined in this thesis. However, problems may be encountered in the future should ribbed stones be identified that do not fit within any of the predetermined types. This creates a where either new types or type variants begin to be defined on a case by case basis, with inconsistencies compounding in each instance. I have attempted to mitigate this by creating a classification system that can describe the form of the artifact using well defined and discrete attributes. This maintains consistency in description while providing flexibility in typology. In regard to the ribbed stones already identified in repositories, the most important part of my research is likely the class definition as it will,

hopefully, provide a means for reliably identifying and describing these artifacts across institutions.

7.2. Use of Circles of Belonging

In contrast to my ribbed stone classification system, circles of belonging is far more conceptual than prescriptive for two reasons. First, circles of belonging can be applied to any collection of artifacts, not just ribbed stones. Second, the circles are created by asking questions about person, place, identify, and activity. Answers to these questions are often subjective, much more so than question about shape or position.

Circles of belonging will, in many cases, rely on historical information that is not strictly archaeological. Traditional knowledge, ethnographic accounts, and historical texts are often necessary to inform or justify what circles an artifact belongs to. Where this practice differs from morphological classification is that the information is incorporated directly into the classification process rather than as supplementary material used to interpret a typology.

A theme, intrinsic to the use of circles of belonging is interconnectivity. Circles may intersect and can also be nested. An Euler diagram was chosen as the basis for this classification system because it demonstrates relationships both within and between groups.

A next step in research using circles of belonging may be to do re-evaluations of site assemblages. Reclassifying artifacts that have already been grouped by form may reveal previously unidentified associations. There is also some potential for cross-cultural studies. It is possible that artifacts, which appear quite different based on form or material type, may occupy the same role in different cultures. These common roles could be identified should the artifacts be found to share many circles.

For example, changes to material culture may represent adaptations to changes in the environment. It is possible that different groups of people adapted to the same changes in their environment with similar strategies but very different changes in material culture. In this case the form of artifacts may not provide any insight into the similarities of these adaptations. Using circles of belonging it may be possible to identify

artifacts that performed similar roles in facilitating environmental adaptations, but are very different in form.

There is always a benefit in having a new toolset to perform a task as common as sorting objects into groups. However, that benefit will need to be explored. It may be that circles of belonging casts too broad a net and that the relationships, while interesting conceptually, can only be supposed rather than demonstrated with certainty.

7.3. Final Remarks

Classification, in particular classification by form, is an essential part of archaeological research. My thesis is meant to be that essential part in the research of ribbed stones. In looking at the history of the archaeology of this artifact class, that basic description and classification appears to have been missed or overlooked. This is most likely because ribbed stones were never the subject of systematic study, They long considered somewhat anomalous pieces of difficult-to-describe material culture within much larger collections.

This study provides a way to define and describe these artifacts and if more should be found they can be identified and recorded with consistency. Through the classification system I developed some patterns in spatial distribution have been tentatively identified. A larger sample, especially one with more dated specimens, will help improve our understanding of these artifacts.

References

Adams, W.Y.

2008 Classification and Typology. In *Encyclopedia of Archaeology*, edited by D.M. Pearsall, pp. 1019-1026. Elsevier, Amsterdam.

Addams, W.Y., and E.W. Addams

1991 *Archaeological Typology and Practical Reality: A Dialectical Approach to Artifact Classification and Sorting*. Cambridge University Press, Cambridge.

Allaire, L.

1978 *L'archeologie des Kitselas D'Après le Site Stratifié de Gitaus (GdTc:2) sur la Rivière Skeena en Colombie Britannique*. National Museum of Man Mercury Series, National Museums of Canada, Ottawa.

1979 The Cultural Sequence of Gitaus: A Case of Prehistoric Acculturation In *Skeena River Prehistory*, edited by R. Inglis and G. MacDonald, pp. 18-52 National Museum of an Mercury Series, Ottawa.

Ames, K.M.

2005 *The North Coast Prehistory Project Excavations in Prince Rupert Harbour, British Columbia: The Artifacts*. BAR International Series 1342. British Archaeological Reports, Oxford.

Andrefsky, W.

2005 *Lithics: Macroscopic Approaches to Analysis*, 2nd ed. Cambridge University Press, Cambridge.

Baimagambetov, A., J. Howse, G. Stapleton, and A. Delaney

2018 Generating Effective Euler Diagrams In *Diagrammatic Representation and Inference: 10th International Conference, Diagrams 2018 Edinburgh, UK, June 18–22, 2018 Proceedings*, edited by P. Chapman, G. Stapleton, A. Moktefi, S. Perez-Kriz, and F. Bellucci, pp. 39-54. Springer International Publishing, Cham.

Boas, F.

1916 *Thirty-first Annual Report of the Bureau of American Ethnology to the Secretary of the Smithsonian Institution, 1909–1910*. Washington Government Printing Office, Washington, DC.

Budhwa, R., and A.F. Hosgood

2016 The Wisdom of Elders. In *Niwhts'ide'nī Hibi'it'ën: The Ways of Our Ancestors Witsuwit'en History & Culture Throughout the Millenia*, 2nd ed, edited by M.H. Morin, pp. 113-114. School District #54 (Bulkley Valley) and Witsuwit'en Language and Culture Authority, Smithers.

- Budhwa, R., and T. McCreary
 2013 Reconciling Cultural Resource Management with Indigenous Geographies: The Importance of Connecting Research with People and Place. In *A Deeper Sense of Place: Stories and Journeys of Indigenous-Academic Collaboration* edited by J.T. Johnson and S.C. Larsen, pp. 195-214. Oregon State University Press, Corvallis.
- Canadian Museum of History
 2020a The Dig. Exhibit produced and curated by the Canadian Museum of History.
 2020b Canada History Hall. Exhibit produced and curated by the Canadian Museum of History.
 2020c Museum Catalog. Maintained by the Canadian Museum of History.
- Cassidy, M.
 2015 *The Gathering Place: A History of the Gitksan-Wet'suwet'en Village of Tse-kya. Hagwilget*. Village Council. Hagwilget, BC.
- Chapman, P., and L. Micallef
 2012 Preface In *Proceedings of the 3rd International Workshop on Euler Diagrams (Euler Diagrams 2012)*, edited by C. Chapman and L. Micallef, pp. v. CEUR-WS.org, Canterbury
- Chesterman, C.W.
 1995 *National Audubon Society Field Guide to North American Rocks and Minerals*. Alfred A. Knopf, New York.
- Childe, V.G.
 1956 *A Short Introduction to Archaeology*. Collier Books, New York.
- Clark, J.E.
 2010 Aztec Dimensions of Holiness. In *The Archaeology of Measurement: Comprehending Heaven, Earth and Time in Ancient Societies* edited by I. Morley and C. Renfrew, pp. 150-169. Cambridge University Press, Cambridge.
- Colton, H.S., and L.L. Hargrave.
 1937 *Handbook of Northern Arizona Pottery Wares*. Museum of Northern Arizona, Bulletin 11. Flagstaff.
- Coupland, G.
 1988 *Prehistoric Cultural Change at Kitselas Canyon*. Canadian Museum of Civilization, National Museums of Canada, Hull.
- Crossroads CRM
 2016a Hagwilget Village/Canyon Burial Grounds. <https://crossroadscrm.com/portfolio/hagwilget-village/>. Accessed March 23, 2020.
 2016b Moricetown Canyon Burial Grounds. <https://crossroadscrm.com/portfolio/moricetown/>. Accessed March 23, 2020.
 2017 Moricetown Recovery Project. <https://crossroadscrm.com/moricetown-recovery-project/>. Accessed March 23, 2020.

- Deetz, J.
 1967 *Invitation to Archaeology*. The Natural History Press, Garden City, NY.
 1996 *In Small Things Forgotten: An Archaeology of Early American Life, Expanded and Revised*. Anchor Press/Doubleday, Garden City, NY.
- de Laguna, F.
 1934 *The Archaeology of Cook Inlet, Alaska*. The University of Pennsylvania Press, Philadelphia.
 1967[1956] *Chugach Prehistory: The Archaeology of Prince William Sound, Alaska*. University of Washington Press, Seattle.
- Esau, K.
 1965 *Plant Anatomy*. Wiley, New York.
- Fullagar, R.
 2006 Residues and Usewear. In *Archaeology in Practice: A Student Guide to Archaeological Analyses* edited by J. Balme and A. Paterson, pp. 207-234. Blackwell Publishing, Malden.
- Garlick, S.
 2014 *National Geographic Pocket Guide: Rocks and Minerals of North America*. National Geographic, Washington, DC.
- Gorodsov, V.A.
 1933 The Typological Method in Archaeology. *American Anthropologist* 35:95-102.
- Hayden, B.
 1979 *Lithic Use-Wear Analysis*. Academic Press, London.
- Hodson, R.F.
 1982 Some Aspects of Archaeological Classification In *Essays on Archaeological Classification*, edited by R. Whallon and J. A. Brown, pp. 21–29. Evanston Center for American Archaeology Press, Evanston
- Hoffman R., and A. Joseph
 2019 *Song of the Earth: The Life of Alfred Joseph*. Creekstone Press Ltd., Smithers.
- Johnson, M.
 2010 *Archaeological Theory: An Introduction*, 2nd ed. Wiley-Blackwell, West Sussex.
- Krieger, A.D.
 1944 The Typological Concept. *American Antiquity* 9(3):271-288.
- Kublo, E.K.
 2007 Spinning and Weaving In *Wood Use in Medieval Novgorod*, edited by M. Brisbane and J. Hather, pp.136–157. Oxbow Books, Oxford.

- Lazzari, M.
2005 The Texture of Things: Objects, People, and Landscape in Northwest Argentina (First Millennium A.D.). In *Archaeologies of Materiality*, edited by L. Meskell, pp. 126-161. Blackwell Publishing, Malden.
- Loy, T., and G.R. Powell

1977 *Archaeological Data Recording Guide*. British Columbia Provincial Museum, Victoria.
- MacDonald, G.F.
1983 Prehistoric Art of the Northern Northwest Coast. In *Indian Art Traditions of the Northwest Coast*, edited by R. Carlson, pp. 99-120. Archaeology Press, Simon Fraser University, Burnaby.
- MacDonald, G.F., J.L. Cove, C.D. Laughlin, and J. McManus
1989 Mirrors, Portals, and Multiple Realities. *Zygon* 24(1):39-64.
- Macdonald, G.F., and R.I. Inglis
1981. An Overview of the North Coast Prehistory Project (1966-1980). *BC Studies* 48:37-63.
- McGrew, J.C., A.J. Lembo, and C.B. Monroe
2014 *An Introduction to Statistical Problem Solving in Geography*, 3rd ed. Waveland Press Inc., Long Grove.
- Millennia Research
2013 3D Mauls and Segmented Stones "In-Situ." <https://millennia-research.com/3d-mauls-and-segmented-stones-in-situ/>. Accessed November 8, 2019.
2014 Archaeological Investigations at Ya asqalu'i/Kaien Siding, Prince Rupert Harbour. Report on file at Museum of Northern British Columbia.
- Miller, J.
1997 *Tsimshian Culture: A Light Through the Ages*. University of Nebraska Press, Lincoln.
- Morin, M.H.
2016 *Niwhts'ide'ní Hibi'it'én: The Ways of Our Ancestors: Witsuwit'en History and Culture Throughout the Millenia*, 2nd ed. School District #54 (Bulkley Valley) and Witsuwit'en Language and Culture Authority, Smithers.
- Morley, I.
2010 Conceptualising Quantification Before Settlement: Activities and Issues Underlying the Conception and use of Measurement. In *The Archaeology of Measurement: Comprehending Heaven, Earth and Time in Ancient Societies* edited by I. Morley and C. Renfrew, pp. 7-18. Cambridge University Press, Cambridge.

- Munsell Rock Color Book
2019 Produced by Munsell Color, Grand Rapids.
- Oxford University Press
2019 Lexico.com. Accessed November 8, 2019.
- Petrie, W.M.F.
1877 *Inductive Metrology or, The Recovery of Ancient Measures from the Monuments*. Hargrove Saunders, London.
- Richards, T.H.
1988 *Microwear Patterns on Experimental Basalt Tools*. BAR International Series, 460. British Archaeological Reports, Oxford.
- Rouse, I.B.
1939 *Prehistory in Haiti: A Study in Method*. Yale University Publications in Anthropology, no. 21. New Haven.
- Sherman, H.M.
2015 The Toothed Blades of Medieval Novgorod In *Aspects of the Design, Production and Use of Textiles and Clothing from the Bronze Age to the Early Modern Era*, edited by K. Grömer and F. Pritchard, pp. 289–293. Natural History Museum, Vienna.
2016 The Flax and Linen of Medieval Novgorod In *Textiles and the Medieval Economy: Production, Trade and Consumption of Textiles 8th – 16th Centuries*, edited by A. Ling Huang and C. Jahnke, pp. 104–112. Oxbow Books, Oxford.
- Smith, L.T.
1999 *Decolonizing Methodologies: Research and Indigenous People*. University of Otago Press, Dunedin.
- Spaulding, A.C.
1953 Statistical Techniques for the Discovery of Artifact Types. *American Antiquity* 18:305-313.
- Spector, J.
1993 *What this Awl Means: Feminist Archaeology at a Wahpeton Dakota Village*. Minnesota Historical Society Press, St. Paul.
- Stantec
2018 2015-0007: Archaeological Impact Assessments Conducted for the Aurora LNG Project Final Permit Report. Report on file with the Archaeology Branch of British Columbia, Victoria.
- Stewart, H.
1973 *Artifacts of the Northwest Coast Indians*. Hancock House Publishers, Saanichton.
1996 *Stone, Bone, Antler & Shell: Artifacts of the Northwest Coast*. Douglas and McIntyre, Vancouver.

- Trigger, B.G.
2006 *A History of Archaeological Thought*, 2nd ed. Cambridge University Press, Cambridge.
- Turner, N.J.
1998 *Plant Technology of First Peoples in British Columbia*. UBC Press, Vancouver.
- Urton, G.
2010 Recording Measure(ment)s in the Inka Khipu. In *The Archaeology of Measurement: Comprehending Heaven, Earth and Time in Ancient Societies* edited by I. Morley and C. Renfrew, pp. 54-68. Cambridge University Press, Cambridge.
- White, C.L.
2008 Individual, Archaeology of in Prehistory. In *Encyclopedia of Archaeology*, edited by D.M. Pearsall, pp. 1508-1510. Elsevier, Amsterdam.
- Willey, G.R., and P. Phillips
1958 *Method and Theory in American Archaeology*. University of Chicago Press, Chicago.
- Wilson, J.
2016 "Belongings" in "čəsnaʔəm: the city before the city."
<https://www.sfu.ca/ipinch/outputs/blog/citybeforecitybelongings/> Accessed May 15, 2020.
- Wilson, S.
2008 *Research is Ceremony: Indigenous Research Methods*. Fernwood Publishing, Winnipeg.

Appendix A. Artifact Reference Catalogue

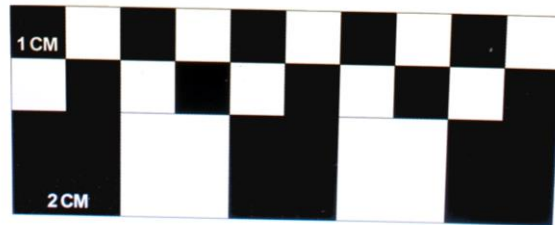

Figure A1. ID 1 (Walter Homewood photo).

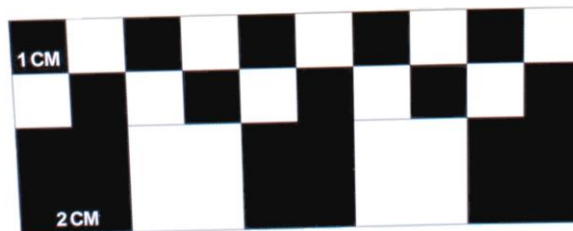

Figure A2. ID 2 (Walter Homewood photo).

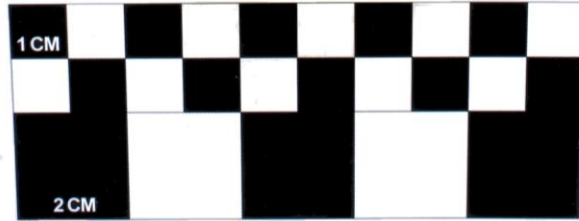

Figure A3. ID 3 (Walter Homewood photo).

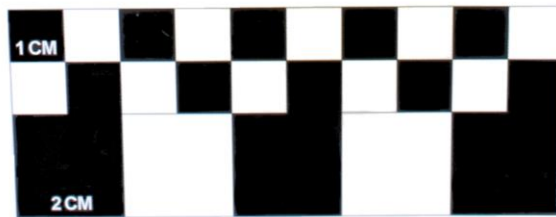

Figure A4. ID 4 (Walter Homewood photo).

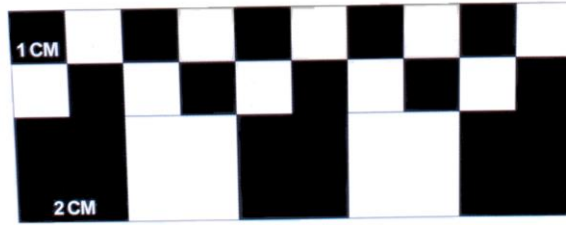

Figure A5. ID 5 (Walter Homewood photo).

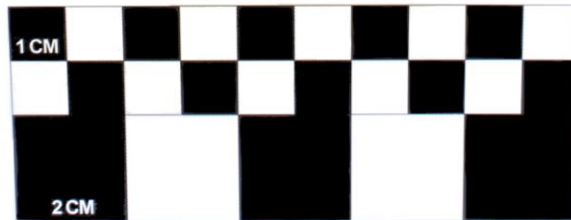

Figure A6. ID 6 (Walter Homewood photo).

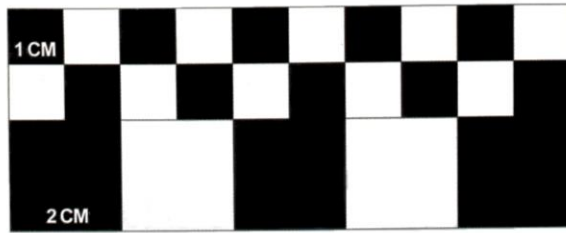

Figure A7. ID 7 (Walter Homewood photo, courtesy of the Canadian Museum of History).

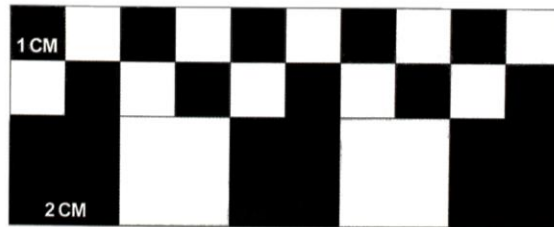

Figure A8. ID 9 (Walter Homewood photo, courtesy of the Canadian Museum of History).

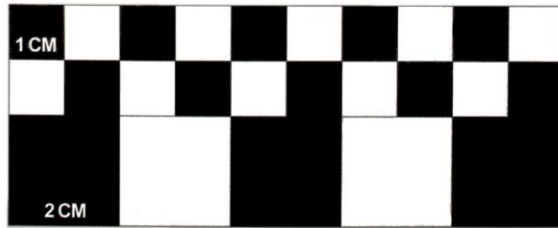

Figure A9. ID 10 (Walter Homewood photo, courtesy of the Canadian Museum of History).

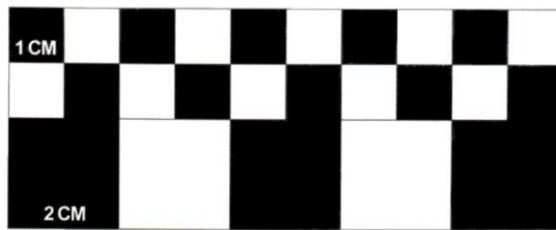

Figure A10. ID 11, photo is of a cast (Walter Homewood photo, courtesy of the Canadian Museum of History).

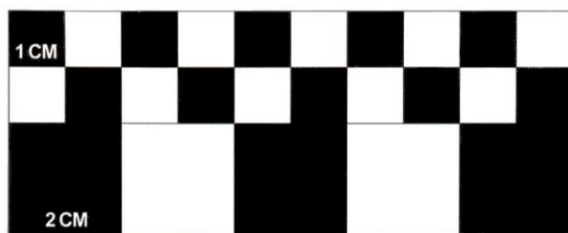

Figure A11. ID 17, photo is of a cast (Walter Homewood photo, courtesy of the Canadian Museum of History).

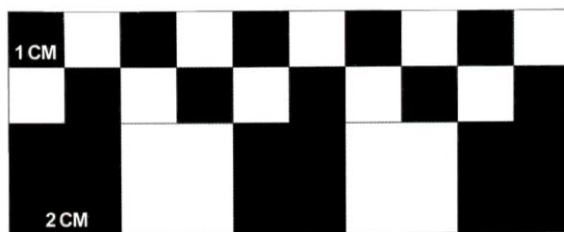

Figure A12. ID 18 (Walter Homewood photo, courtesy of the Canadian Museum of History).

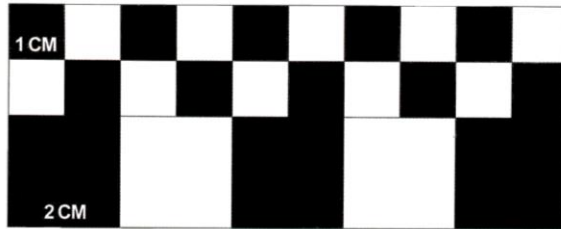

Figure A13. ID 19 (Walter Homewood photo, courtesy of the Canadian Museum of History).

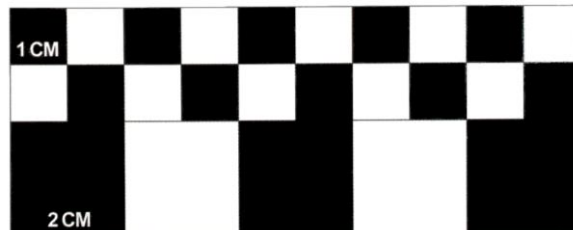

Figure A14. ID 20 (Walter Homewood photo, courtesy of the Canadian Museum of History).

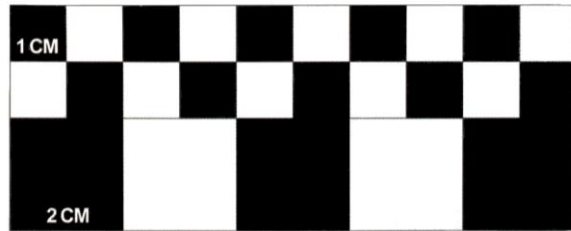

Figure A15. ID 21 (Walter Homewood photo, courtesy of the Canadian Museum of History).

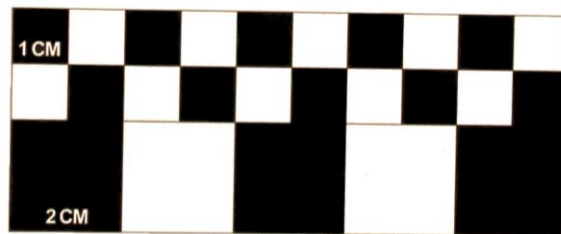

Figure A16. ID 22 (Walter Homewood photo).



Figure A17. ID 23 (Walter Homewood illustration).

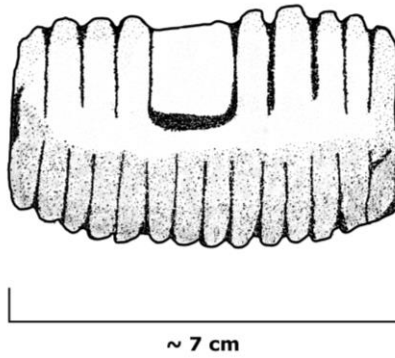

Figure A18. ID 24 (Walter Homewood illustration).

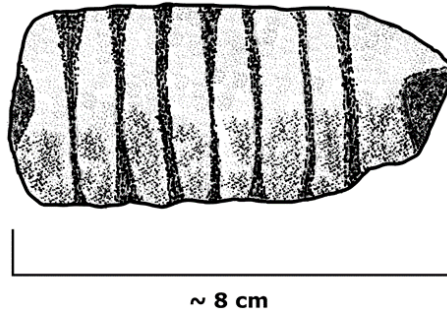

Figure A19. ID 25 (Walter Homewood illustration).

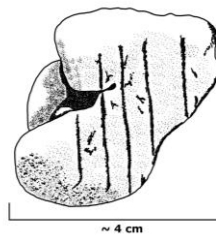

Figure A20. ID 26 (Walter Homewood illustration).

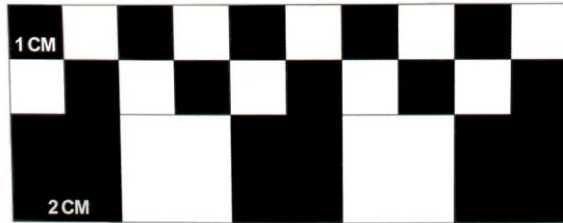

Figure A21. ID 27 (Walter Homewood photo)

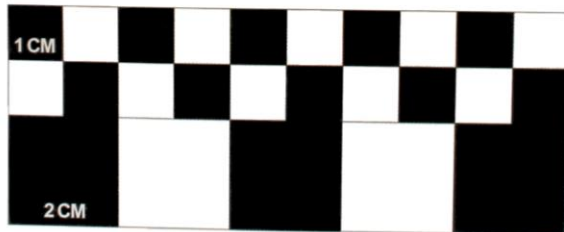

Figure A22. ID 28 (Walter Homewood photo).



Figure A23. ID 29 (Walter Homewood photo).



Figure A24. ID 30 (Walter Homewood photo).

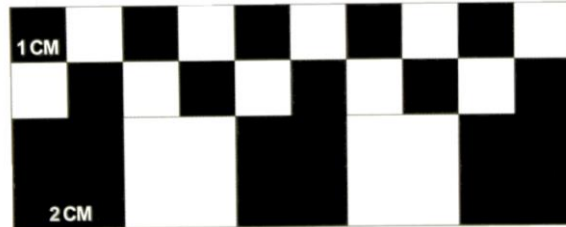

Figure A25. ID 31 (Walter Homewood photo).

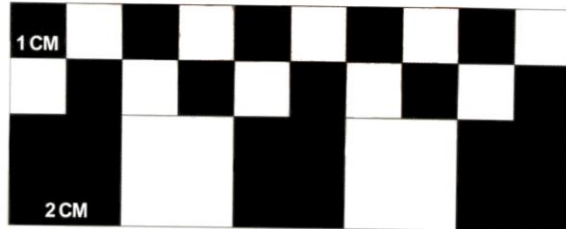

Figure A26. ID 32 (Walter Homewood photo).

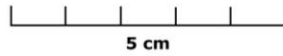

Figure A27. ID 35 (Andrew Eckert photo, copyright Millennia Research Limited, used with permission).

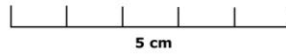

Figure A28. ID 36 (Andrew Eckert photo, copyright Millennia Research Limited, used with permission).

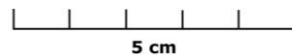

Figure A29. ID 37 (Andrew Eckert photo, copyright Millennia Research Limited, used with permission).

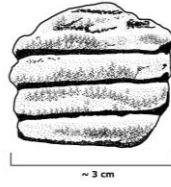

Figure A30. ID 38 (Walter Homewood illustration).

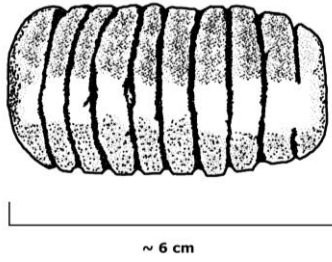

Figure A31. ID 39 (Walter Homewood illustration).

Appendix B. Excluded Artifacts

Six artifacts from the Gitaus site in Kitselas Canyon that were originally described as ribbed or notched stones by Allarie (1978, 1979) (see Chapter 2) do not fit within my definition of ribbed stones. Allaire (1978:334) described four artifacts as “les ornemants à entailles [notched ornaments],” which he used synonymously with “notched stones” in a later publication (1979:41-44). I consider these four artifacts (Figure B1) to be what de Laguna (1967[1956]:126-128) described as “notched whetstones.” Instead of deeply incised grooves that extend across the entirety of at least one face of the artifact, these have shallow grooves along the edges. The edge is quite thin compared to the rounded face of a ribbed stone. While many ribbed stones have the end profile of an ellipse, the end profile of a “notched whetstone” is that of a pointed oval, with almost sharp edges where the notches have been incised (Figure B2).

The differentiation of “notched whetstones” from ribbed stones is based on my own interpretation of the artifact class. I see the two classes as different: one having shallow incision along an edge that is pointed in profile, the other having deep incisions along a face that is flat or rounded in profile. This differentiation may be seen as arbitrary. The two classes may be one and the same. This could be determined through an investigation into the function of both. Frederica de Laguna posited that “notched whetstones” were used for “shaping and sharpening small stone and bone objects” (de Laguna 1934:124). This is a distinctly different interpretation than any proposed for ribbed stones. However, should the function of these artifacts be demonstrated to be the same, they should be considered as the same class and representative of the variation between types. This would significantly increase the geographical range of ribbed stones beyond British Columbia and into Alaska.

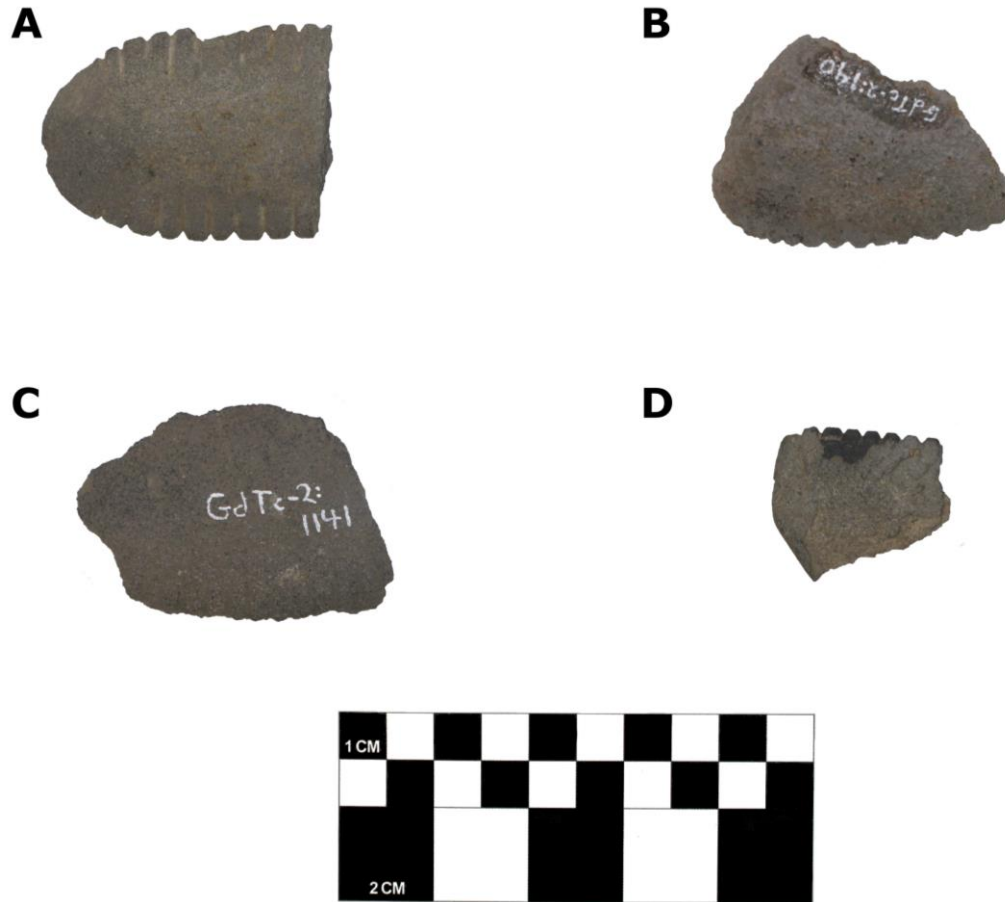

Figure B1. Notched whetstones from Kitselas Canyon. Canadian Museum of History catalog numbers: A) GdTc-2:507; B) GdTc-2:140; C) GdTc-2:1141; D) GdTc-2:547 (Walter Homewood photo, courtesy of the Canadian Museum of History).



Figure B2. End profile of a so called “notched whetstone” (Walter Homewood illustration).

One of Allaire’s notched ornaments appears very similar in form to a unilateral harpoon point (commonly made of bone) out of schist (Millennia Research 2014:324) (Figure B3). It bears little resemblance to ribbed stones, having only one groove girdling the artifact at one end and coming to a point at the other.



Figure B3. A schist artifact from Kitselas Canyon resembling a barbed harpoon point. Canadian Museum of History catalog number GdTc-2:649 (Walter Homewood photo, courtesy of the Canadian Museum of History).

Another of Allaire's notched ornaments (Figure B4) appears to be a pendant, given that its perforated. No other ribbed stones were observed to have perforations and although the this artifact does have incised grooves, the presence and location of the perforation give the artifact a very similar appearance another artifact (Figure B5) found at the Dodge Island site that was identified as a pendant (Canadian Museum of History 2020c).



Figure B4. A pendant from Kitselas Canyon. Canadian Museum of History catalog number GdTc-2:476 (Walter Homewood photo, courtesy of the Canadian Museum of History).



Figure B5. A pendant from the Dodge Island site (GbTo-18). Canadian Museum of History catalog number GbTo-18:698 (Walter Homewood photo, courtesy of the Canadian Museum of History).

Appendix C. A Guide to Ribbed Stone Typology

This guide is based on the classification system presented in this thesis. All steps of the classification system can be completed through a visual inspection in the field or laboratory.

The terms used for artifact orientation of the faces of the artifact are side, end, top and bottom (Figure C1). An “end” is the artifact face bounded by the thickness and width; each artifact has two ends. A “side” is the artifact face bounded by the length and thickness; each artifact has two sides. The “top” and “bottom” are the faces bounded by the length and width; top and bottom can be used interchangeably and do not refer to a universal orientation.

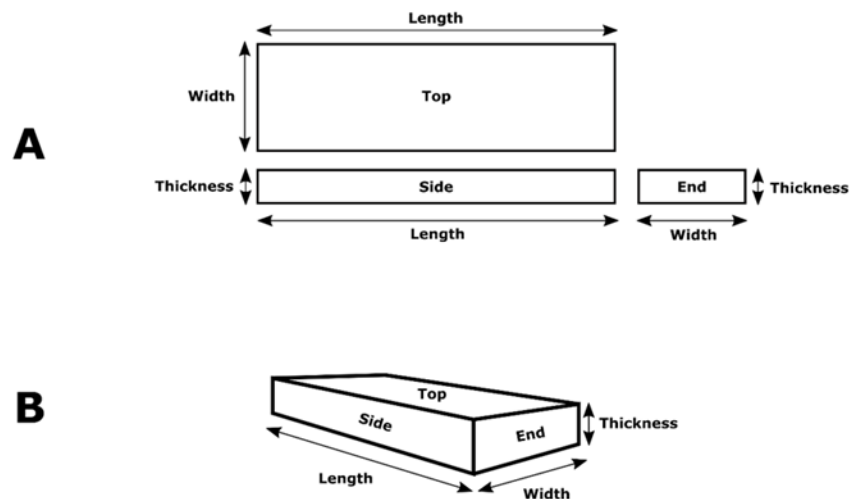

Figure C1. Describing artifact orientation: A) profile view; B) perspective view (Walter Homewood illustration).

Step 1: Determining Artifact Class

The first step is to determine if the artifact in question belongs in the ribbed stone artifact class, as described in Table C1. The most important characteristic is the pattern of deeply incised grooves that extend across the entirety of at least one face of the artifact, creating a ribbed pattern of raised bands. This pattern must be present on the artifact for it to be considered a ribbed stone.

Some generalized characteristics of ribbed stones are that the artifact material is most commonly sandstone or similar (e.g. siltstone). Uncommon materials include scoria and lignite. The artifact should appear to have been made by grinding (i.e., not by flaking, chipping, or pecking). Ribbed stones have been observed to be between 3 to 15 cm in length, 2 to 7 cm in thickness, and 1 to 7 cm in width, with weight ranging from 7 to 384 g.

Table C1. Ribbed stone class definition.

Ribbed Stone	
Material Type	A ribbed stone is most commonly made of sandstone or similar sedimentary rock such as siltstone. However, there have been examples of ribbed stones made of scoria (a type of basalt), and lignite (which is often found within sandstone). The texture of the material is rough and abrasive.
Manufacturing Technique	Ribbed stones are made by grinding, i.e., ribbed stones are shaped by rubbing the artifact with or against an abrasive surface.
Form	Ribbed stones are characterized by deeply incised grooves that extend across the entirety of at least one face of the artifact, creating a ribbed pattern of raised bands. The grooves are aligned parallel to each other and are most commonly aligned perpendicular to the length of the artifact. Ribbed stones vary in shape, but are typically an elliptical cylinder or tabular in profile. Ribbed stones range in size from approximately 3 to 15 cm in length, 2 to 7 cm in thickness, and 1 to 7 cm in width. Artifact weight ranges from approximately 7 to 384 grams.

If the artifact is determined to be a ribbed stone, Steps 2-7 can be followed to determine the ribbed stone type. Steps 2-6 are independent of each other and the results of following any of these steps does not influence the results of the others. Different characteristics of ribbed stones (e.g., shape and decoration) can be examined jointly or in isolation to allow researchers to explore different relationships between the types. Step 7 is dependant on the results of Steps 2-6 and can only be completed if the attributes in each of the preceding steps have been assessed.

Step 2: Determining Shape

There are four shape types within the ribbed stone artifact class: tabular; elliptical cylinder; cylindrical cylinder; and amorphous. Shape is primarily determined by viewing the artifact from the end profile.

Tabular

The tabular shape is rectangular in cross section when viewed from the ends, sides, top and bottom (Figures C2-C3).

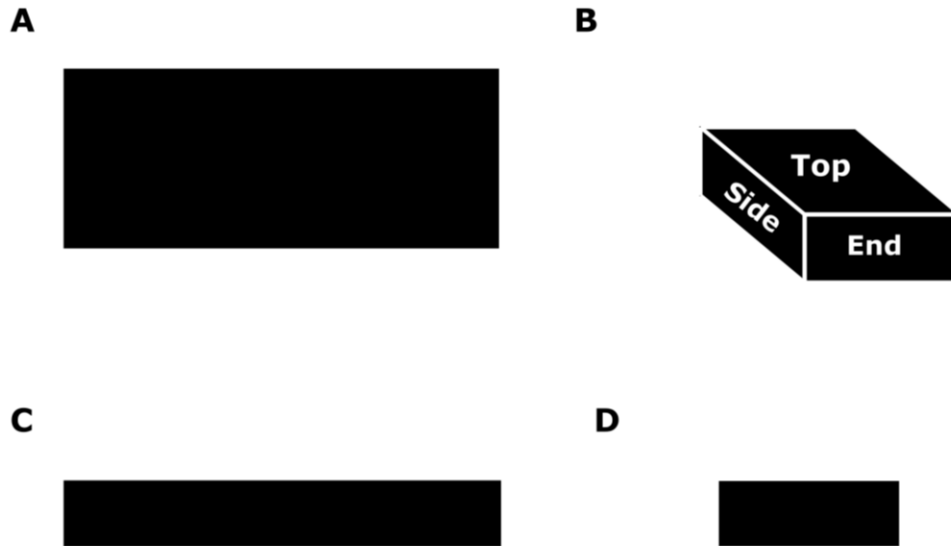

Figure C2. Generalized tabular profile: A) top; B) 3D perspective; C) side; D) end (Walter Homewood illustration).

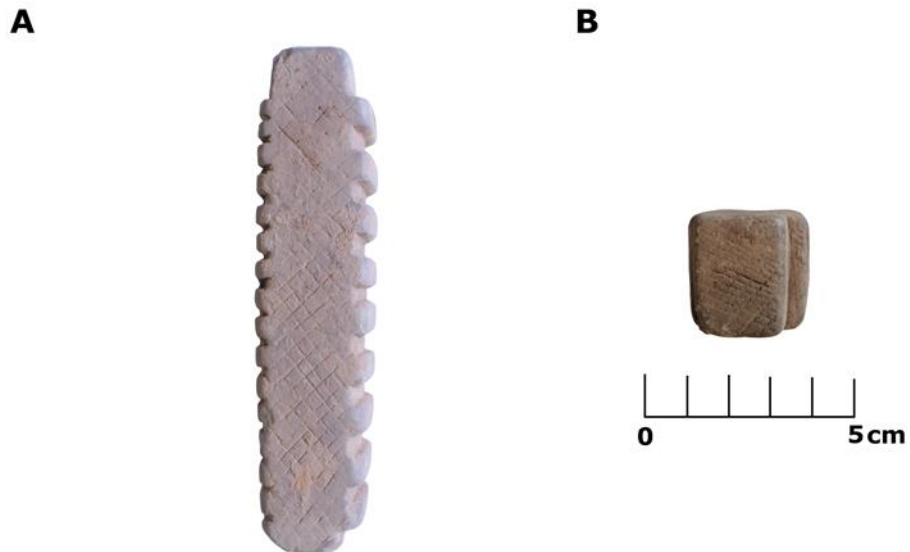

Figure C3. Tabular shape example: A) top profile; B) end profile (Walter Homewood photo).

Elliptical Cylinder

The elliptical cylinder shape is an ellipse in cross section when viewed from the ends and is rectangular in cross section when viewed from the sides, top and bottom (Figures C4-C5).

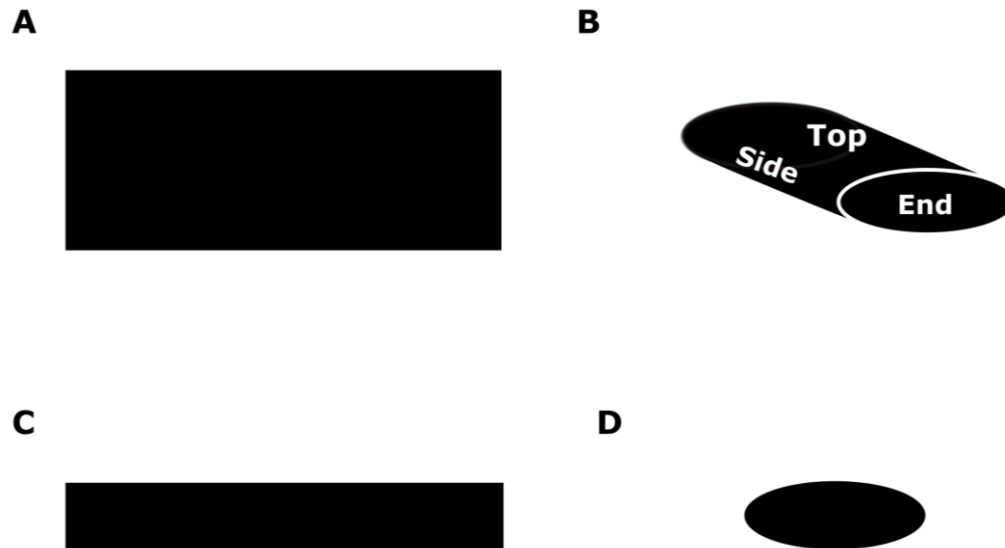

Figure C4. Generalized elliptical cylinder profile: A) top; B) 3D perspective; C) side; D) end (Walter Homewood illustration).

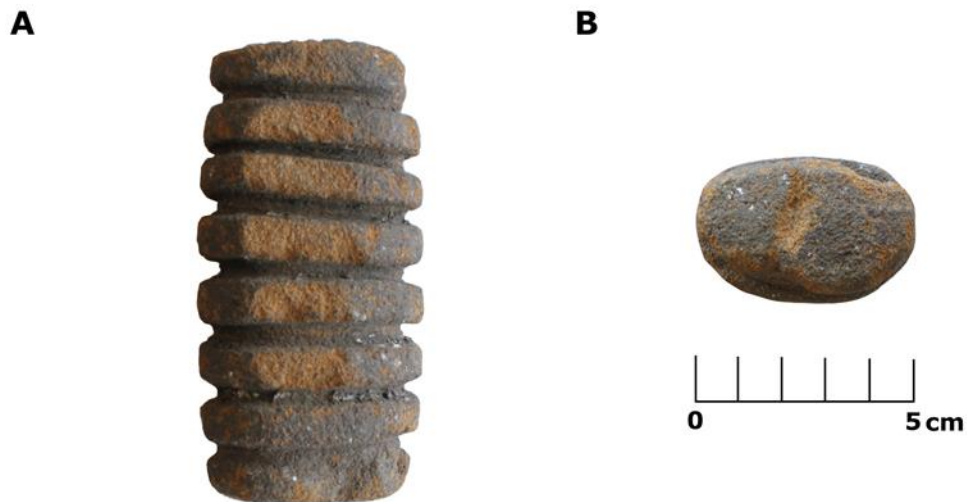

Figure C5. Elliptical cylinder shape example: A) top profile; B) end profile (Walter Homewood photo).

Circular Cylinder

The circular cylinder shape is a circle in cross section when viewed from the ends and is rectangular in cross section when viewed from the sides, top and bottom (Figures C6-C7). The side, top, and bottom orientations are all case sensitive as the artifact will have the same, or very nearly the same, width and thickness.

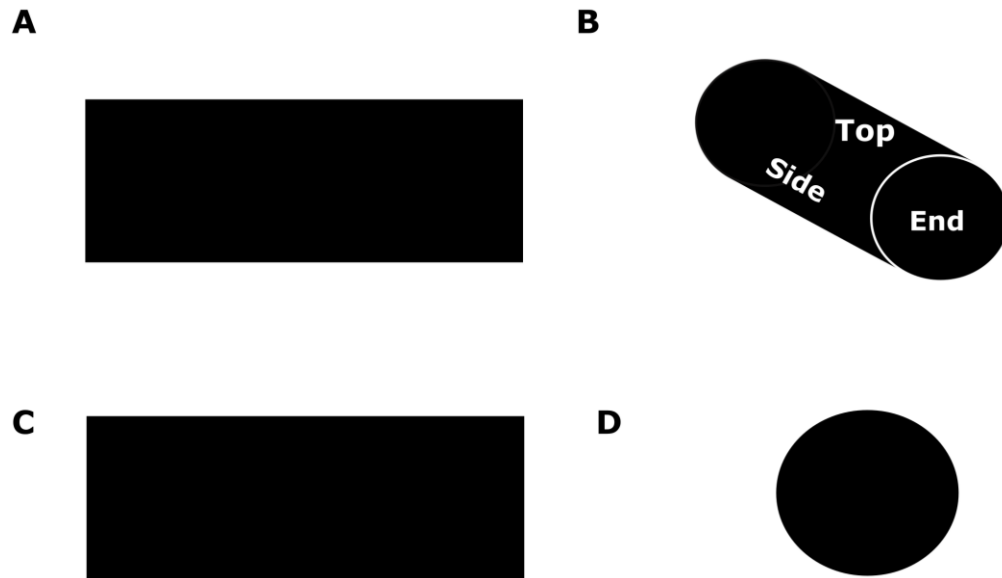

Figure C6. Generalized circular cylinder profile: A) top; B) 3D perspective; C) side; D) end (Walter Homewood illustration).

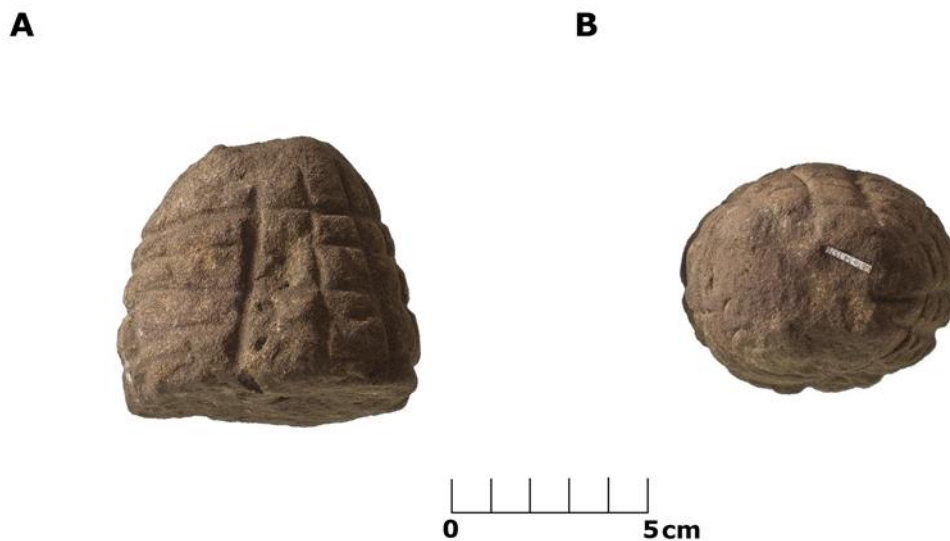

Figure C7. Circular cylinder shape example: A) top profile; B) end profile (Andrew Eckert photo, copyright Millennia Research Limited, used with permission).

Amorphous

A ribbed stone is considered to have an amorphous shape if the artifact has an irregularly shaped profile (Figures C8-C9). The artifact is neither rectangular, elliptical, or circular when viewed from the end, top, or sides.

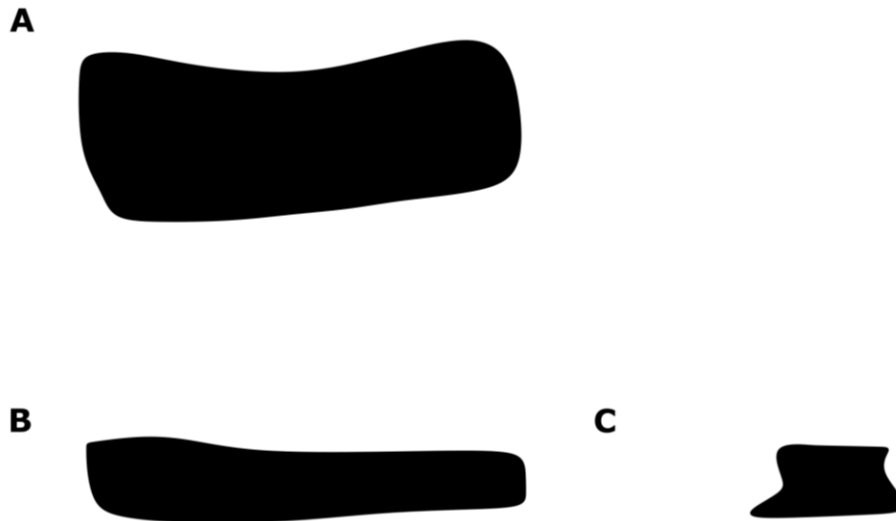

Figure C8. Generalized amorphous profile: A) top; B) side; C) end (Walter Homewood illustration).

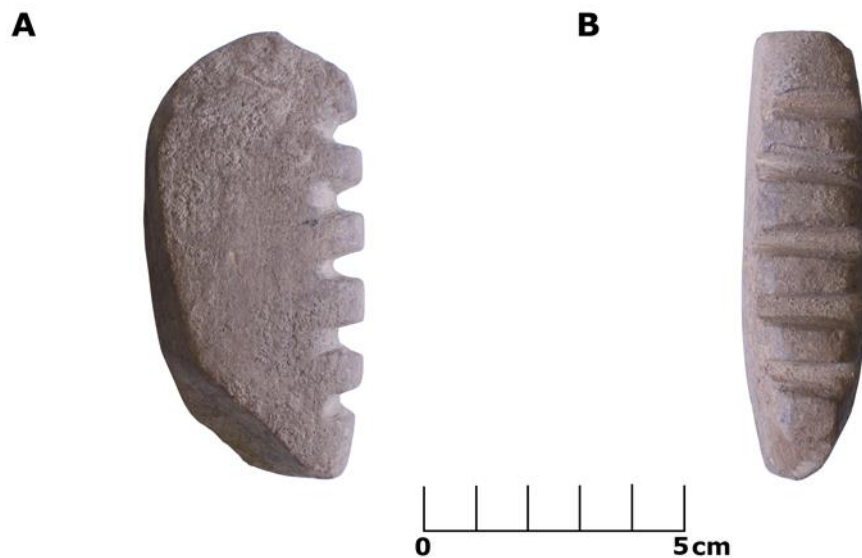

Figure C9. Amorphous shape example: A) top profile; B) side profile (Walter Homewood photo).

Step 3: Determining Groove Location

There are four types of ribbed stones based on groove locations: 1-sided, 2-sided, 4-sided, and girdled. Groove location is determined based on the number of faces that have grooves extending across the entirety of the surface.

1-sided

The artifact is 1-sided if it has grooves along only one face (Figure C10). The grooves may be along one side, the top, or the bottom.

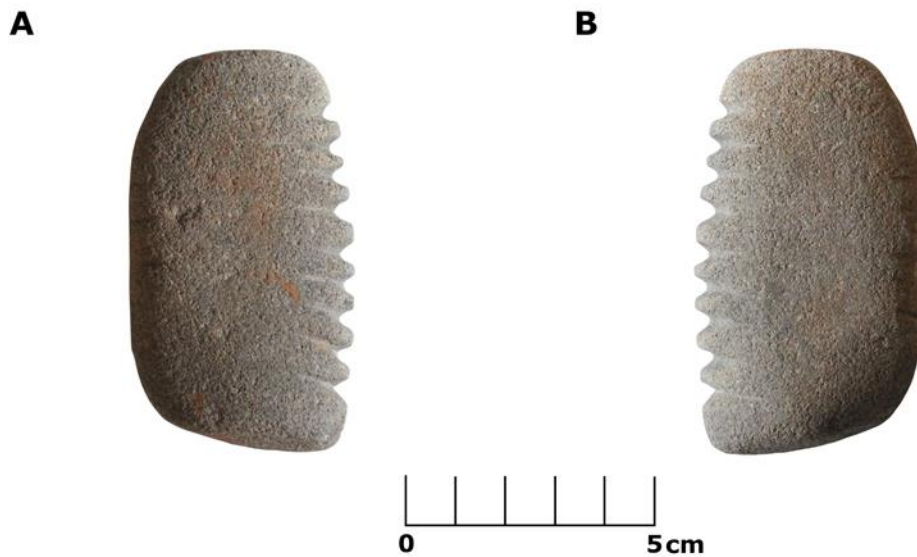

Figure C10. 1-sided example: A) top profile; B) bottom profile (Walter Homewood photo).

2-sided

A ribbed stone is 2-sided if it has grooves on two faces of the artifact. The faces can be opposite or adjacent, e.g., the artifact has grooves on the two opposing sides, the artifact has grooves on the top and bottom, or the artifact has grooves on one side and the top or bottom (Figures C11-C12).

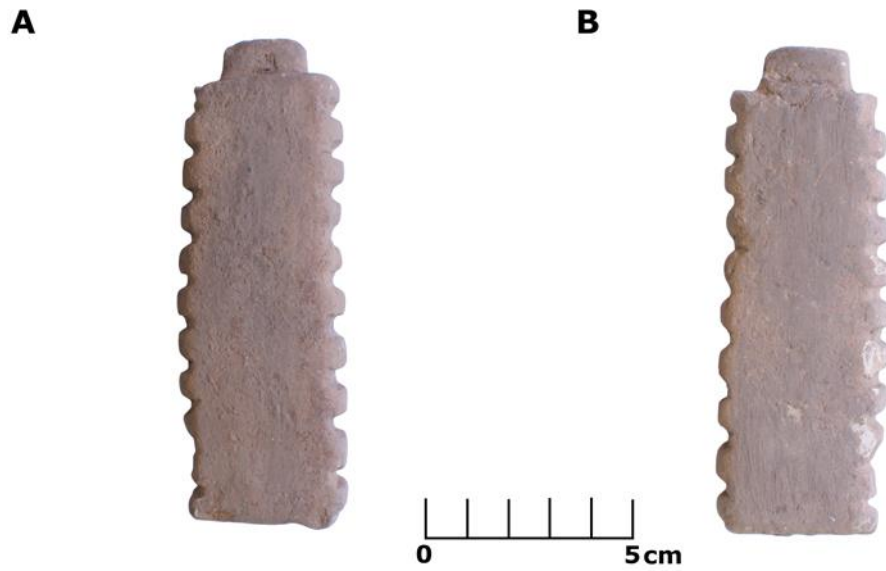

Figure C11. 2-sided with grooves on opposing sides example: A) top profile; B) bottom profile (Walter Homewood photo).



Figure C12. 2-sided with grooves on adjacent side and bottom example (photo is of a cast): A) top profile, B) bottom profile; C) side profile; D) opposing side profile. (Walter Homewood photo, courtesy of the Canadian Museum of History).

4-sided

A ribbed stone is 4-sided if the artifact has grooves on four faces and the grooves are not continuous (Figure C13).

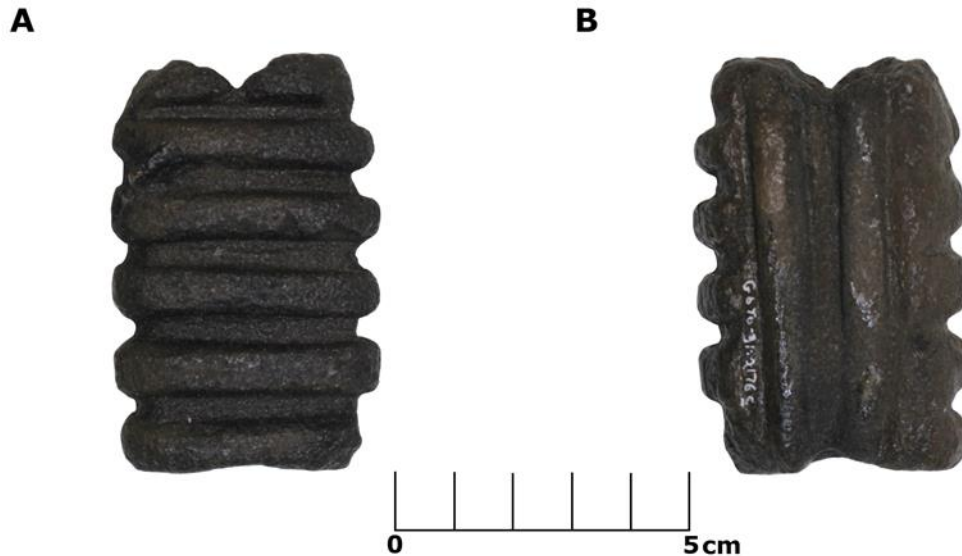

Figure C13. 4-sided example (photo is of a cast): A) top profile; B) bottom profile (Walter Homewood photo, courtesy of the Canadian Museum of History).

Girdled

A ribbed stone is girdled if the artifact has continuous grooves encircling it (Figure C14). Not all of the grooves need be continuous, but more than one groove must be present.

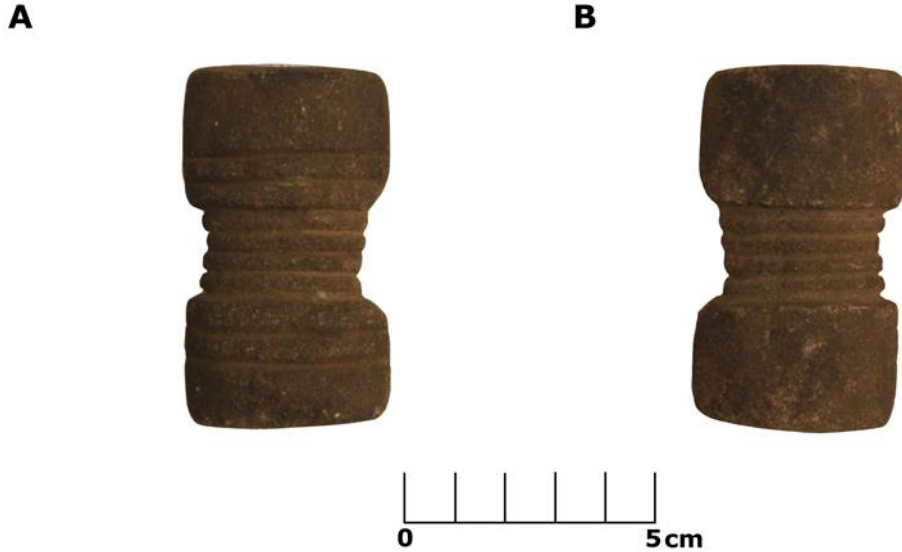

Figure C14. Girdled example: A) top profile; B) bottom profile (Walter Homewood photo).

Step 4: Determining Groove Direction

The directions of ribbed stone grooves are either parallel or perpendicular to the length of the artifact. Grooves are most commonly oriented perpendicular to the length. There are examples of ribbed stones with grooves oriented in both the perpendicular and parallel directions; ribbed stones of with grooves in both directions are described as bidirectional. No examples exist of ribbed stones with an exclusively perpendicular groove direction.

Perpendicular

Groove direction is perpendicular to the length of the artifact (Figure C15).



Figure C15. Perpendicular grooves example: top profile (Walter Homewood photo, courtesy of the Canadian Museum of History).

Parallel

Groove direction is perpendicular to the length of the artifact. No ribbed stone with exclusively perpendicular grooves have been observed.

Bidirectional

Grooves are both perpendicular and parallel. Both types may be present on the same face (Figure C16) or on different faces (Figure C17).



Figure C16. Bidirectional groove direction on same face, example: top profile (Walter Homewood photo).

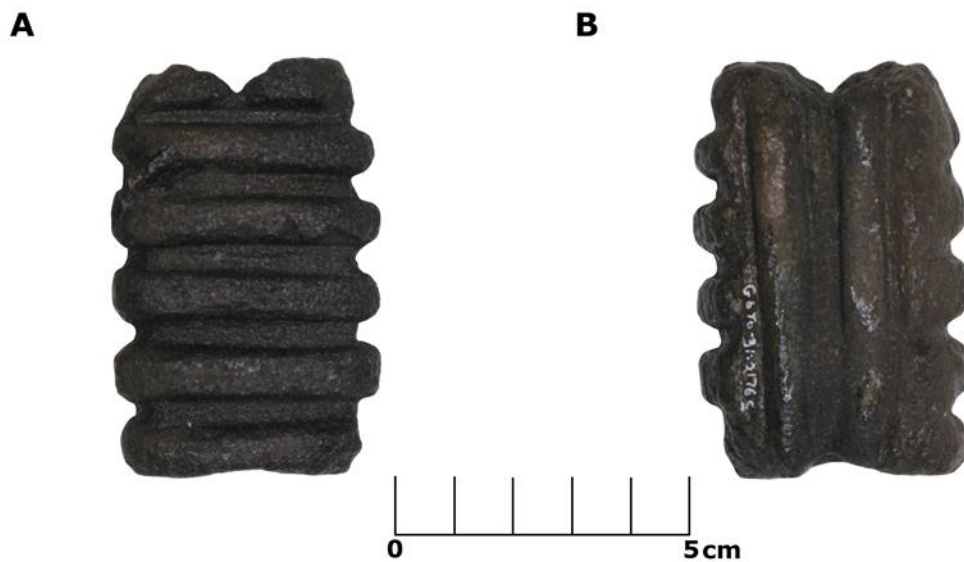

Figure C17. Bidirectional groove direction on different faces, example (photo is of a cast): A) top profile; B) bottom profile (Walter Homewood photo, courtesy of the Canadian Museum of History).

Step 5: Determining Groove Width

Groove widths are described in two ways, single-width or multi-width.

Single-width

Grooves have approximately the same width (Figure C18).



Figure C18. Single-width example: top profile (Walter Homewood photo).

Multi-width

Grooves appear to be two or more different widths. The difference in groove widths should be apparent based on a visual inspection (Figure B18).



Figure C19. Multi-width example: top profile (Walter Homewood photo, courtesy of the Canadian Museum of History).

Step 6: Determining Decoration

Ribbed stones can be undecorated or decorated, the latter may be geometric or zoomorphic. For the purposes of ribbed stone typology the characteristic pattern of raised bands is not considered decoration.

Undecorated

Aside from the ribs, there are no designs, markings, or patterns incised into the surface of the artifact (Figure C20).

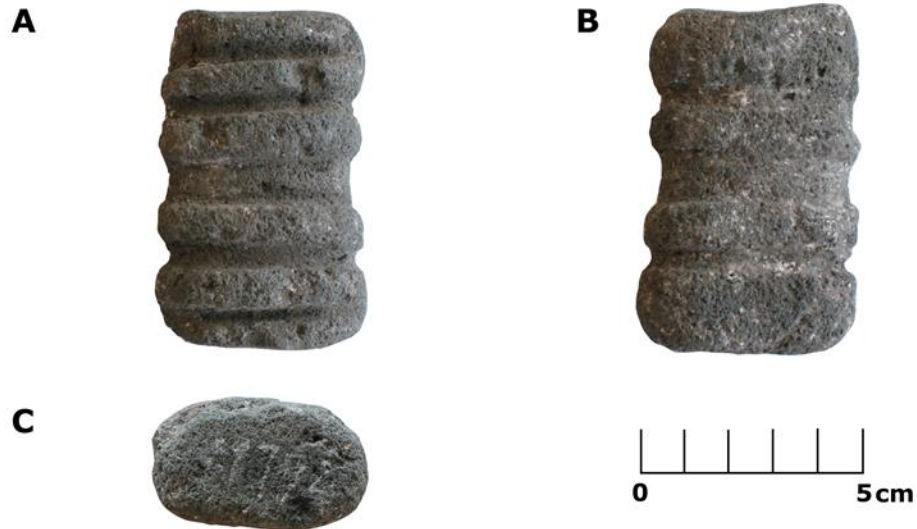

Figure C20. Undecorated example: A) top profile; B) bottom profile; C) end profile. (Walter Homewood photo)

Geometric

The artifact has incised markings that create a geometric pattern. The incised pattern must be separate and distinct from the characteristic pattern of deeply incised grooves that extend across the entirety of at least one face of the artifact, creating a ribbed pattern of raised bands (Figure C21).

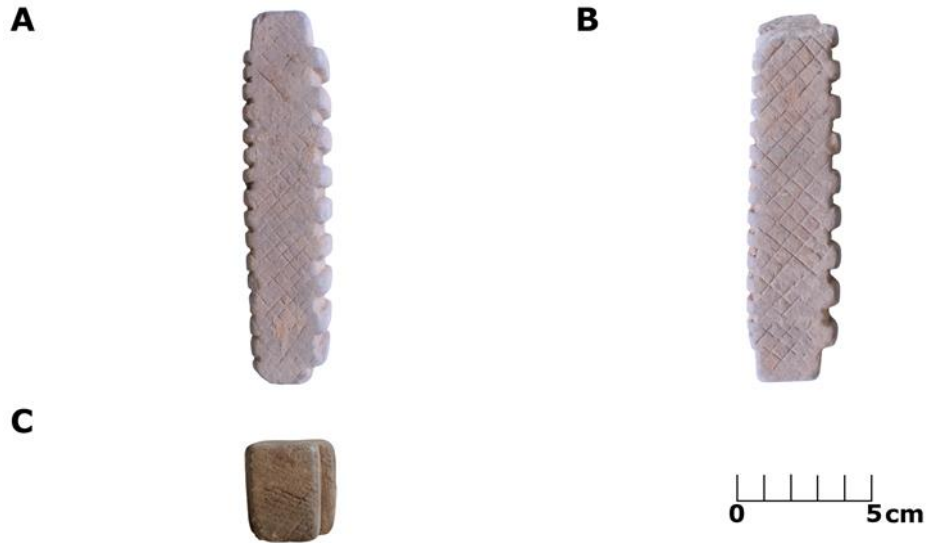

Figure C21. Geometric decoration example: A) top profile; B) bottom profile; C) end profile (Walter Homewood photo).

Zoomorphic

Incised markings create a pattern that represent an animal or parts of an animal (e.g., eyes, legs) (Figure C22). In the case of a zoomorphic decoration, the characteristic ribbed pattern may be incorporated into the decoration, representing the ribs of an animal.



Figure C22. Zoomorphic decoration (photo is of a cast): A) top profile, B) bottom profile; C) side profile; D) opposing side profile. (Walter Homewood photo, courtesy of the Canadian Museum of History).

Step 7: Determining the Descriptive Type

The descriptive type is determined by the combined attributes defined in Steps 2-6. The determination of a descriptive type is not possible in all cases (e.g., if the artifact is too fragmented to determine groove location). The descriptive types split ribbed stones into the largest number of groups, with only a small number of ribbed stones sharing all the same attributes.

The combined attributes are read in the order: shape; groove location; groove direction; groove width; decoration, and when taken together provide a concise, but thorough description of the artifacts form. An example of such a description is an amorphous, 1-sided, perpendicular, single-width, undecorated ribbed stone. Within this thesis each description has been given a letter which serves as a shorthand “type code,” for easier reference in the text (Table C2). The current list of descriptive types is not exhaustive, and it is possible that newly recovered ribbed stones may not fit into any of the types listed and represent an additional descriptive type.

Table C2. Ribbed stone descriptive types and type codes.

Type Description	Type Code
amorphous, 1-sided, perpendicular, single-width, undecorated	A
elliptical cylinder, 2-sided, perpendicular, multi-width, undecorated	B
elliptical cylinder, girdled, perpendicular, single-width, undecorated	C
elliptical cylinder, 2-sided, perpendicular, single-width, undecorated	D
elliptical cylinder, 2-sided, perpendicular, single-width, geometric	E
tabular, 1-sided, perpendicular, single-width, undecorated	F
circular cylinder, girdled, bidirectional, single-width, undecorated	G
amorphous, 2-sided, perpendicular, single-width, undecorated	H
amorphous, 2-sided, perpendicular, multi-width, zoomorphic	I
amorphous, girdled, perpendicular, single-width, undecorated	J
tabular, 2-sided, perpendicular, single-width, undecorated	K
tabular, 2-sided, perpendicular, multi-width, geometric	L
tabular, 2-sided, perpendicular, multi-width, undecorated	M
tabular, 2-sided, bidirectional, multi-width, undecorated	N

Included below is a quick reference sheet of the ribbed stone classification system (Table C3). The classification system is presented in its original form as a series of entries. When considered sequentially the progression through the entries produces the same results as following the steps outlined above. Entries 6-10 constitute the attributes of the descriptive types.

Table C3. The ribbed stone classification system.

Entry	Entry Name	Modifiers Used	Description
1	Category	Artifact	An object showing one or more of the following: evidence of intentional modification, evidence of use, evidence that it has been selected for possible use (Loy and Powell 1977:12).
2	Material Class	Stone	A consolidated or coherent and relatively hard, naturally formed mass or aggregate of mineral matter (Loy and Powell 1977:66).
3	Material Type	Sandstone	A clastic sedimentary rock with generally rounded particles of sand size (Chesterman 1995:715).
		Siltstone	A clastic sedimentary rock with particles of silt size (Chesterman 1995:714).
		Lignite	A form of coal, intermediate between peat and bituminous coal. Seams are often found interbedded with sandstone (Chesterman 1995:728-729).
		Scoria (Basalt)	A type of basalt with a rough and abrasive texture. (Chesterman 1995:688).
4	Manufacturing Technique	Ground	A method of artifact modification by rubbing with or against an abrasive surface (Loy and Powell 1977:51).
5	Artifact Class	Ribbed Stone	See ribbed stone class definition described above (Table B1).
6	Shape	Circular Cylinder	The artifact has the profile of a circular cylinder.
		Elliptical Cylinder	The artifact has the profile of an elliptical cylinder.
		Tabular	The artifact has the profile of a rectangular prism.
		Amorphous	The artifact has an irregularly shaped profile.
7	Groove Location	1-Sided	The artifact has grooves on one side.
		2-Sided	The artifact has grooves on two sides.
		4-Sided	The artifact has grooves on four sides; the grooves are not continuous.
		Girdled	The artifact has continuous grooves encircling the artifact.
8	Groove Direction	Perpendicular	The grooves are perpendicular to the length of the artifact.
		Parallel	The grooves are parallel to the length of artifact.
		Bidirectional	There are both perpendicular and parallel grooves in the artifact.
9	Groove Width	Single-width	The grooves are all approximately the same width.
		Multi-width	There is a difference in approximate groove widths on different sides.
10	Decoration	Geometric	The artifact has geometric design.
		Zoomorphic	The artifact has a design that resembles an animal.
		Undecorated	The artifact is not decorated.