

# Galena Electric Power – a Situational Analysis



Robert E. Chaney, SAIC Corporation  
Stephen G. Colt, University of Alaska Anchorage  
Ronald A. Johnson, University of Alaska Fairbanks  
Richard W. Wies, University of Alaska Fairbanks  
Gregory J. White, Idaho National Engineering & Environmental Laboratory

DRAFT Final Report  
December 15, 2004

Prepared for the U.S. Department of Energy  
National Energy Technology Laboratory  
Arctic Energy Office Contract  
DE-AM26-99FT40575

#### DISCLAIMER

This report was prepared as an account of work sponsored by an agency of the United States Government. Neither the United States Government nor any agency thereof, nor any of their employees, makes any warranty, express or implied, or assumes *any* legal liability or responsibility for the accuracy, completeness, or usefulness of any information, apparatus, product or process disclosed, or represents that its use would not infringe privately owned rights. References herein to any specific commercial product, process, or service by trade name, trademark, manufacturer, or otherwise, does not necessarily constitute or imply its endorsement, recommendation, or favoring by the United States Government or any agency thereof. The views and opinions of authors expressed herein do not necessarily state or reflect those of the United States Government or any agency thereof.

## EXECUTIVE SUMMARY

### Purpose

The purpose of the investigation is to compare the economics of various electrical power generation options for the City of Galena. Options were assessed over a 30-year project period, beginning in 2010, and the final results were compared on the basis of residential customer electric rates (\$/kWh).

Galena's electric utility currently generates power using internal combustion diesel engines and generator sets. Nearby, there is an exposed coal seam, which might provide fuel for a power plant. Contributions to the energy mix might come from solar, municipal solid waste, or wood. The City has also been approached by Toshiba, Inc., as a demonstration site for a small (Model 4S) nuclear reactor power plant.<sup>1</sup> The Yukon River is possibly a site for in-river turbines for hydroelectric power. This report summarizes the comparative economics of various energy supply options.

This report covers:

- thermal and electric load profiles for Galena
- technologies and resources available to meet or exceed those loads
- uses for any extra power produced by these options
- environmental and permitting issues and then
- the overall economics of each of the primary energy options.

### Loads

Currently, the city buildings, school, swimming pool, and health clinic space heating needs are met by capturing the heat rejected by the diesel electric generators (DEGs) and transferring the hot water to the buildings (all close to the power plant). We have assumed an existing average cogeneration load of 400 K Btu/hr for 8 months per year plus a 300 K Btu/hr [commercial/residential boiler load] for other buildings in town for eight months. This gives a total yearly cogeneration thermal load [CTLoad] projected for the future of about 4 B Btu. (Northern Resource Group, 2004). We have distributed these over a year using Fairbanks heating degree days [HDD] data. Analysis shows that allowing for expansion and additional customers for heat (the Air Station), the heat delivered annually could be about 8 B Btu in the future.

In **Figure ES.1**, we see the monthly electric energy generated. This results in an annual load slightly under 10 M kWh. The average monthly load was around 800 kW in July and over 1 MW in January.

---

<sup>1</sup> Subsequent to release of this report in draft form, Toshiba has offered clarifications to their proposal. First, due to current US regulations and fuel availability, the fuel would probably be manufactured and the reactor charged in a US nuclear facility (i.e. Argonne National Laboratory). Toshiba's assumption is that the reactor would be returned to that location for decommissioning. Second, the capital cost would be borne by a third party (to be determined) that would become the plant owner and responsible for decommissioning. Changes to the text have been made to reflect these assumptions.

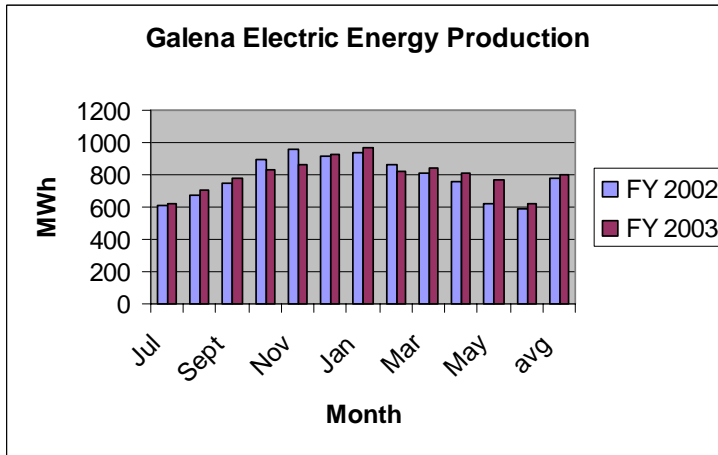


Figure ES.1. Monthly electric generation for Galena

Taking the equivalent projected heating loads and adding the electric loads over the year yields the load requirements displayed in **Figure ES.2.** for the year 2010.

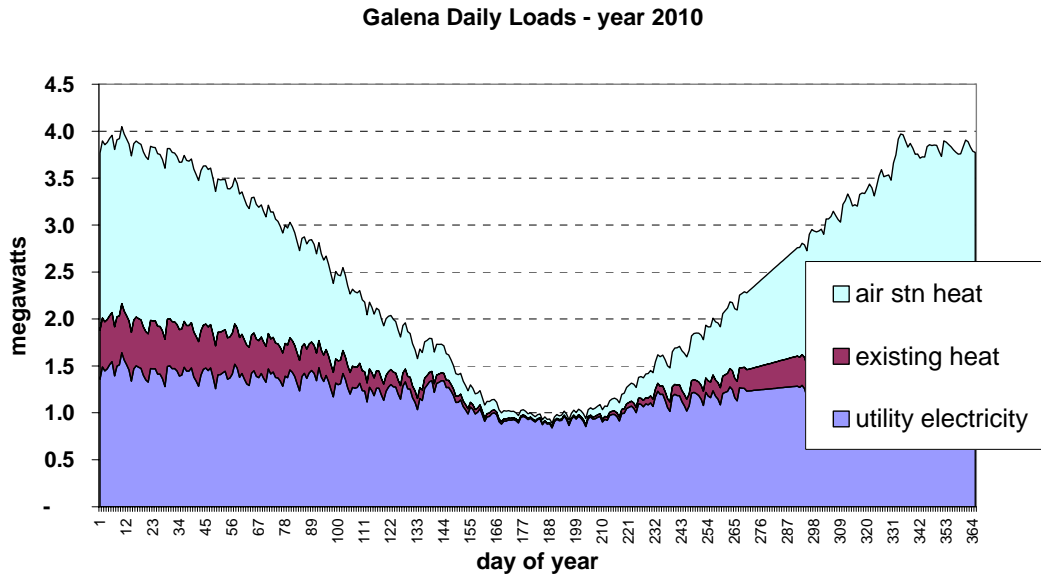
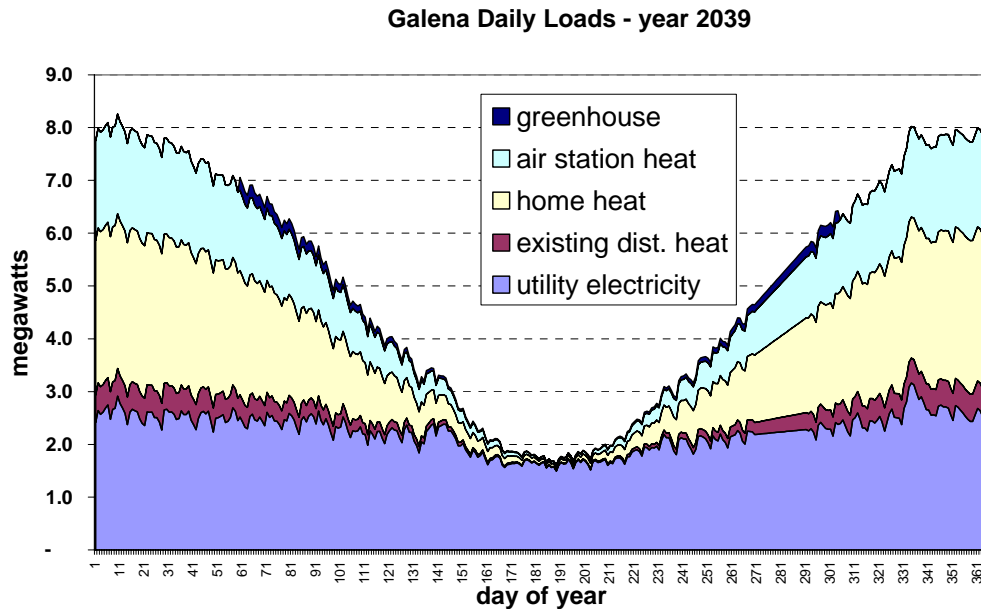


Figure ES.2. Combined heating and electrical loads based on current use in Galena

The various generation options available have different output capacities. For example, the Toshiba 4S system has a generation capacity of 10 MW. Thus, extra power would be available. If the rates were sufficiently low, residential space heating might be an option, as would commercial activities including greenhouses and aquaculture. **Figure ES.3.** illustrates a possible profile using the base loads from **Figure ES.2** with the addition of some of these options for the year 2039. The power requirements are about 8 MW. This would still leave extra power for other uses.



**Figure ES.3.** Projected combined loads for 2039 with residential space heating and one 2000 ft<sup>2</sup> greenhouse.

**Power Generation Options**

The three systems assessed in depth were enhanced diesel, coal (mine and power plant), and the Toshiba 4S nuclear reactor. In the later two cases, backup diesel generators were retained to provide power during any time the primary system was down for repairs or maintenance. All economic analyses included the cost of the backup diesel system.

**Enhanced Diesel.** According to the Rural Alaska Energy Plan (MAFAa, 2002), the most efficient village sized DEGs available today are capable of achieving peak efficiencies in the 15.8 kWh/gal range. With a fuel oil having a heating value of 135 K Btu/gal, this is equivalent to converting 40% of the energy in the fuel to electric power. For the past two years, the Galena average monthly electrical generation efficiency varied from about 13.2 to 14.8 kWh/gal and averaged 13.76 kWh/gal. For this analysis, we assumed that the units currently in use will continue to perform at 14 kWh/gal and any upgraded or new units will operate at 15 kWh/gal.

**Coal (Mine & Power Plant).** Exposed coal seams are about 18 road miles upriver from Galena near the Loudon town site. This deposit is not well-understood. Before much further analysis is attempted, the deposit must be explored to determine its size and very importantly its depth below the surface. Samples have been analyzed and have shown an estimated heating value averaging 9.4 K Btu/lb (18.6 M Btu/ton), sulfur content less than 0.5%, ash averaging 9 % [range 2 – 16 %], and moisture content averaging 19% [14 to 28%]. One exposed seam is about 9 feet high and 2,000 feet across. [Phillips and Denton, 1990]. If a 1-MW coal-fired plant were to operate with an efficiency of 25%, it would require about 0.68 tons/hr of coal or about 12,000 ft<sup>3</sup>/month. If a 100-foot width were taken from this 9-foot-high coal seam, 13 ft/month or 166 feet/yr

## Pre-Publication Draft – Subject to Change

would have to be excavated. This coal might be delivered to Galena for an estimated \$100 to \$128/ton.

Atmospheric fluidized-bed combustion (AFBC) boilers are now well-established as a mature power generation technology with more than 620 AFBC units in operation worldwide in the size range 20 to 300 MW. Current operating experience shows that AFBC boilers meet high environmental standards and are commercially viable and economically attractive. For more information on AFBCs see <http://www.epri.com/journal/details.asp?id=627&doctype=features>

These plants burn a range of fuels, including bituminous and subbituminous coal, coal waste, lignite, petroleum coke, biomass, and a variety of waste fuels. In many instances, units are designed to fire several fuels (including biomass fuels), which emphasizes one of the technology's major advantages: its inherent fuel flexibility.

While no AFBC coal power plants in the small size range required at Galena have been built and operated at this time, small AFBC boilers have been used to provide heat for industrial processes. Adaptation to power production requires the addition of a steam turbine and ancillary equipment.

The U.S. Department of Energy (DOE) initiated a study in 1998 (Northern Economics, 2001) to investigate the capital and operating costs of small coal-fired power plants [600 kW to 2 MW]. The installed capital costs were estimated at from \$3.0K to \$4.3K/kW and an electricity cost of \$0.22 to \$0.77/kWh.

A 2003 feasibility study on a barge-mounted 5-MW AFBC power plant (Bonk, 2004) estimated capital costs from \$20M to \$25M and electricity costs of \$0.20/kWh minus a credit for heat delivered using Galena coal.

J.S. Strandberg (1997) did a feasibility analysis of an 800 kW AFBC coal plant in McGrath plus a 125 kW DEG. The analysis estimated a total project budget of about \$14 million, which included the power plant, coal mine development, haul road, and an expanded district heating system. The estimated electricity cost was \$0.176/kWh, which included a \$0.077/kWh credit for heat delivered. Over half the total cost was for coal and limestone. A major issue was the high parasitic power required [over 155 kW], and the estimate for it was increased as the study was completed.

Phillips and Denton (1900) calculated costs for a 483 kW coal-fired model cogeneration facility producing 6.8 M Btu/hr of heat. The costs of electricity ranged from \$0.11 to \$0.22/kWh for a base load plant to as much as \$0.80/kWh for a lightly loaded plant. Of the 21 M Btu/hr fuel input, 46% went to the production of electricity. Of the total capital cost of \$7.5 M, \$2.0 M was allocated to electrical and +\$5.5 M to heat. For a plant in Galena using Loudon coal, the electricity costs were estimated to range from \$0.26 to \$0.36/kWh.

A coal-fired plant should be a base-load plant sized to run near its capacity all of the time except for planned shutdowns for maintenance and repair.

**Toshiba 4S Nuclear Plant.** The 4S Model power plant concept is based on a design for a Small Innovative Reactor (SIR), which is a sealed unit. Unlike conventional

## Pre-Publication Draft – Subject to Change

reactors, the 4S concept is for the sealed reactor to be delivered at the site, installed with the generator system, operated for the prescribed design life, removed, and replaced with the sealed assembly intact. Thus, there would be no emissions (other than steam), no release of radioactivity, and minimum chance of radiation exposure when the reactor assembly is buried. Toshiba has approached the City with a proposal to provide the reactor and power plant so that the 4S can have a reference site and gain operational experience. The capital cost would be borne by a third party to be identified. Some expense may be incurred by the City for site preparation and installation.

The 4S has no mechanical systems internal to the sealed assembly. Electromagnetic pumps move the cooling fluid. The reflecting shield that controls the reaction is also moved electromagnetically. This greatly reduces the potential for mechanical and equipment problems. Cooling and heat transfer is accomplished using liquid sodium metal. Heat is transferred to a steam generation loop and the resulting steam drives the turbine to generate electricity with rejected heat in the condensed water available for district heating or other uses. For district heating, the steam can be used directly. Problems that have occurred in sodium-cooled plants design have been in sections of the plant other than the reactor.

In this concept, the nuclear reactor is planned to be installed up to 100 feet below grade and capped with reinforced concrete. This provides a nearly impenetrable barrier that cannot be lifted by any heavy equipment available in Galena. The 4S also uses a nonproliferation fuel that cannot be used to produce a nuclear weapon without first undergoing isotopic enrichment, an extremely costly and technologically challenging process.

The projected 4S capital cost is projected to be \$2,500/kW for the 50-MW model when developed. If these assumption scales for a 10 MW unit, the capital cost would be \$25 million.<sup>2</sup> If fully utilized, electric power from the 50-MW unit is estimated by the vendor to be \$0.065/kWh. Our economic analysis proved to be highly sensitive to the number of plant personnel required. A reasonable number of operations personnel are required for efficiency and safety, but it is not known how many security personnel may be required. A detailed safety and security risk assessment, required by the Nuclear Regulatory Commission licensing process, will determine the necessary staffing levels. The time required for the NRC licensing process is not known at this time. It may add a significant period before the plant can be started, but for purposes of this analysis, we assumed a start date in 2010. The experience gained from the Galena project will be used to refine capital and installation cost estimates for future installations.

### Other Generation Modules

Although, other options for power were considered, they were not viable for large-scale deployment by the utility. These include solar, wind, in-river turbines, biomass, fuels cells, and coal bed methane.

**In-river Turbines.** Prototype turbines have been developed but have not been demonstrated in arctic settings. Calculations of the power output from candidate models

---

<sup>2</sup> Toshiba presented this estimate with slides describing the 50-MW plant. We have used the cost per kW figure and applied it to the smaller size. Due to economies of scale, this approach may understate the cost of the smaller, 10-MW plant. However, we are unaware of a direct cost estimate for the 10-MW size.

## Pre-Publication Draft – Subject to Change

indicate the output would be relatively low at Galena (22.5 kW for a unit with two 3m diameter turbines). For these reasons, we did not pursue or recommend installation of in-river turbines at this time.

**Solar.** Much of interior Alaska has a good solar resource for as much as eight months of the year, including the springtime when there is a large need for both heat and electricity. A downside to using solar energy is the intermittent nature of the resource. Hence, as with any intermittent resource, storage can be a key issue. Solar technologies take two forms, solar-electric (photovoltaic) and solar thermal. Photovoltaic devices convert sunlight directly to electricity at efficiencies as high as 25%, although 10% is typical. Installation of a 100 kW module in a Galena setting could cost \$2M. Solar thermal technologies use the heat in sunlight to produce hot water, heat for buildings, or electric power. In Galena, solar technology would best serve individual home or business owners. Its impact on the utility was determined to be limited.

**Biomass.** Biomass can be wood from trees as well as plant residue, animal waste, and the paper portion of municipal solid waste (MSW). The dispersed nature of this resource makes the energy and time involved in harvesting an important issue. We determined the contribution from this source to be too small for a stand-alone unit. However, MSW could be burned in the AFBC of the coal power plant.

**Wind.** Galena is located in a low wind resource region – Class 1. For wind turbines to work efficiently and contribute significantly to a utility, they must operate in a Class 5, 6, or 7 region. Thus, wind was not considered.

**Fuel Cells.** This technology is under intense development but has not been commercialized. While some demonstrations are underway, fuel cells are not available for utility applications at this time.

**Coal Bed Methane.** Gas has been produced commercially from coal beds in the lower 48. Development of resources in other parts of Alaska is in a preliminary stage. Because information to develop CBM in arctic conditions is insufficient, CBM cannot be considered for Galena. If considered for development, extensive work is required to delineate local reserves before development could occur.

### Conservation

Conserving energy can reduce loads for utilities and reduce consumer power bills. Utilities have a role in providing information on conservation to their customers. This report discusses measures that can be taken by end-users to conserve.

### Uses of Extra Power

Some power plant options have optimum sizes that would provide power over and above current and projected electrical consumption. For those cases, possible uses studied included district heating, residential electric baseboard heating, transmission to nearby villages, production of hydrogen, and horticulture/aquaculture. Use of all energy produced by generation options is essential to realize the full economic potential of generation systems.



## Pre-Publication Draft – Subject to Change

**District Heating/Heat Sales.** Currently, DEGs provide heat to City buildings, the school, and swimming pool. This is assumed to continue in all of the scenarios considered. Some expansion is assumed. Also considered is the sale of heat through a hot water pipeline to the Air Station. To provide space heating, the Air Station consumes about the same volume of fuel oil each year as the electric utility. The value of the heat supplied is equivalent to the value of the displaced fuel oil.

**Electric Space Heating to Residences.** If electric rates can be lowered sufficiently, residents will begin to use more electricity in their homes. With sufficiently low rates, many will convert to electric baseboard heating systems. The only reasonable option here is the 4S nuclear plant. If this situation were to be realized, retrofitting the homes and upgrading the distribution system would result in economies of scale, increased convenience, and enhancement of in-door air quality. In considering the economics of the 4S option, the costs of retrofitting and installation were included in the capital cost to the utility.

**Hydrogen Production.** Projected electric and heat loads over the 30-year life of this analysis indicate that extra power will still be available. In considering other potential uses, we assessed the production of hydrogen for fuel. Transportation of hydrogen for sale outside the City was determined to not be economical. However, under certain conditions, converting City vehicles, school district buses, and Air Station heavy equipment may be economically feasible. It might also provide the City the opportunity to be a test-bed for production and use of hydrogen in remote arctic settings. Hydrogen production may be feasible but not economically viable without subsidies. No credit was taken for the oxygen that is coproduced, but it could be captured and compressed for local use.

**Transmission to other villages.** An analysis of estimated construction costs of transmission lines to the villages nearest to Galena revealed that the capital costs were several million dollars greater than the revenue that could be collected over the 30-year period. This option is therefore not considered feasible from an economic standpoint.

**Greenhouses and Aquaculture.** The extra heat produced by new power plants may give rise to private entrepreneurial activities. We briefly looked at the potential of greenhouses and aquaculture. Many other activities may be viable. If the cost for the heat (in the form of heated water) were low enough, these ventures appear to have merit.

### Environmental Issues and Permitting

Issues related to permitting were surveyed for the generation options considered viable. The critical considerations are

- Air pollution control
- Water pollution control
- Waste management
- Disturbance of lands/habitat

After considering all issues and potential emissions, the 4S option appears to be the least problematic (this depends on the Nuclear Regulatory Commission) from the

## Pre-Publication Draft – Subject to Change

standpoint of ease of gaining new permits. Opening a coal mine and building a coal-fired power plant appears to be the most difficult.

### Economic Analyses

Estimating the cost of power to the consumer is the primary objective of this project. We considered the three options: improved diesel, coal (mine & power plant), and the Toshiba 4S nuclear power plant. In all cases, the base case was taken as the continuation and improvement of the diesel-based system now in place. The most critical parameters for each option are shown below.

In the base case, two extremes were taken. First, the continuation of diesel generation with a fuel cost of \$1.50/gal at a flat rate (no escalation). The second case took the cost of fuel at \$2.15/gal and escalated it at 2%/year. These cases were used to compare all the others. For the coal option, the delivered cost of the fuel and the conversion efficiency of the plant were the variables on which the power cost most depends. For the 4S option, the staffing levels (the plant operation staff was held constant, but the number of security personnel was varied) required were the most important.

**Table ES.1.** Most critical parameters for each option considered.

	units	low value	high value
Diesel fuel price in 2010	\$/gallon	1.50	2.15
Diesel fuel price increase (over and above general inflation)	% per year	0.0%	2.0%
Coal price (delivered to Galena)	\$/ton	100	125
Coal plant average efficiency		30%	40%
Nuclear plant security staff	positions	4	34

Numerous scenarios were run showing the effect of various assumptions. The power plant sizes, optimized for the various technologies, were taken with the load and energy uses, and the total project cost, as well as the electricity cost to the consumer, was calculated. The figures below show the results for various scenarios beginning in 2010. The coal and nuclear systems assumed that DEGs would be employed as back-up for maintenance and emergency shutdowns. Therefore, the price of diesel fuel affects the economics of those systems.

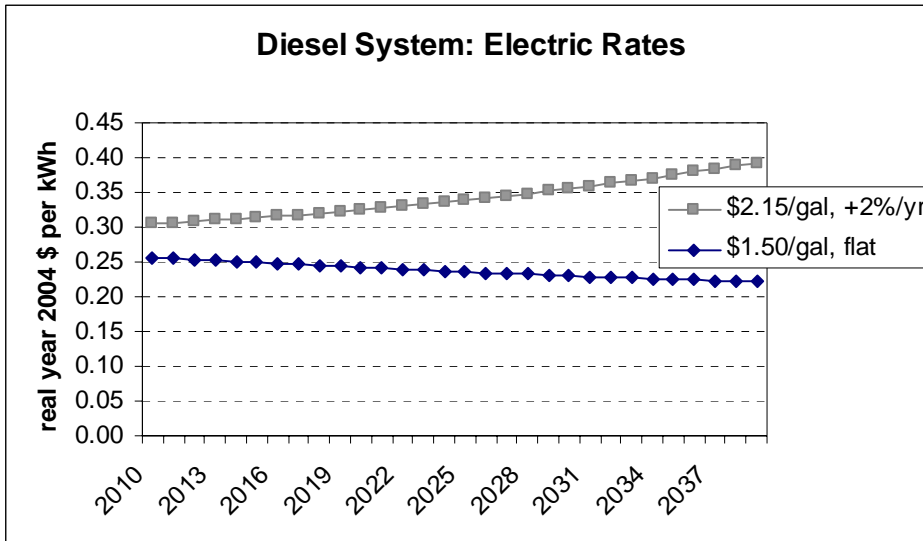


Figure ES.4. Projected future electric rates with a diesel system.

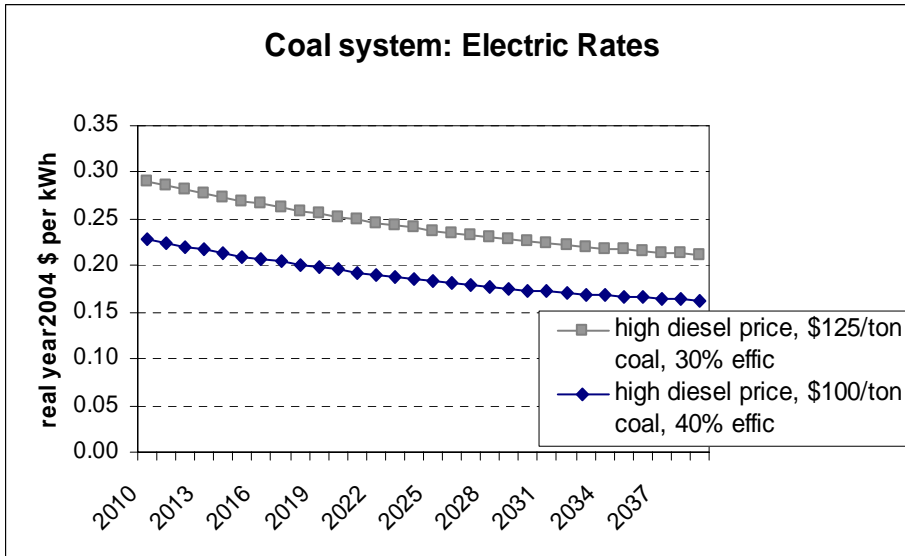


Figure ES.5. Projected future electric with rates with coal system.

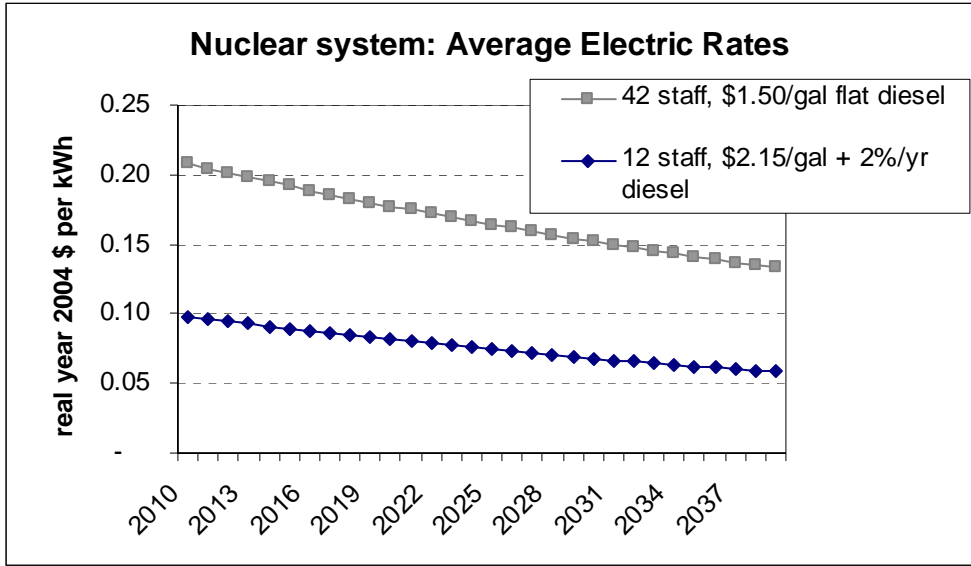


Figure ES.6. Projected future electric rates with nuclear system.

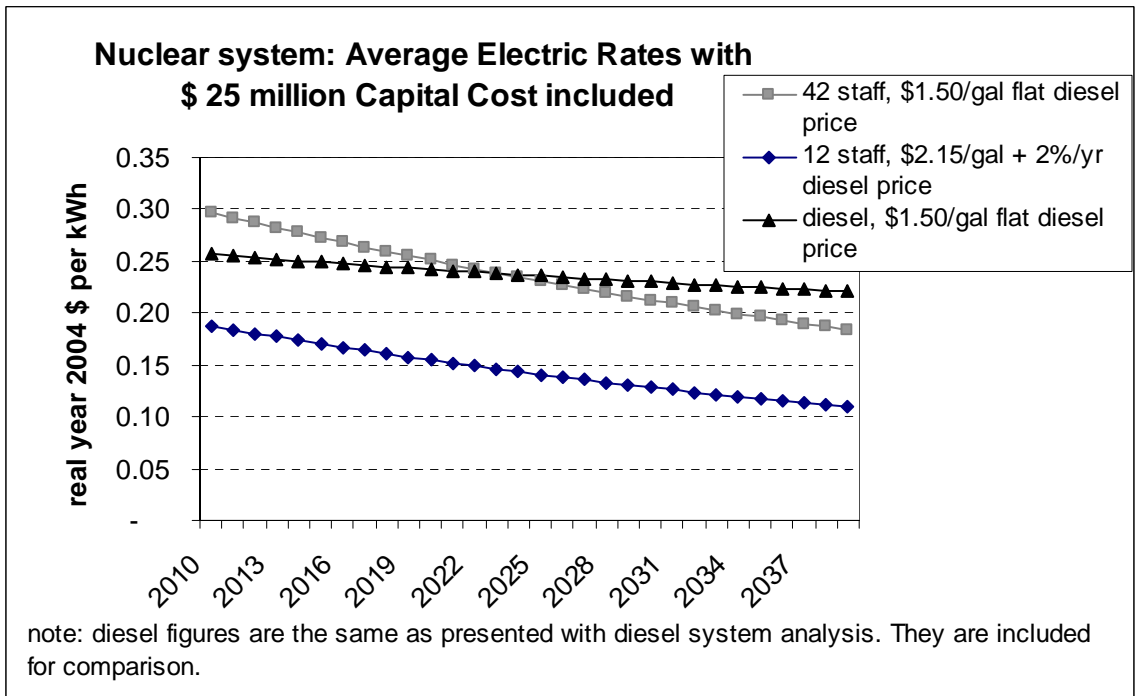


Figure ES.7. Projected future electric rates with nuclear capital costs included in rates.

ES.2. Summary of results of the economic evaluations

## Pre-Publication Draft – Subject to Change

	Diesel	Nuclear	Coal
Loads served:			
utility electricity	X	X	X
existing district heat	X	X	X
residential electric space heat		X	
greenhouse		X	
air station district heat		X	[sometimes]
Life-cycle total cost (\$million)			
low value	38	(7)	23
high value	59	35	36
Net benefits compared to diesel (\$million)			
low value		3	3
high value		67	36
Average electric rate in 2010 (\$/kW h)			
low value	0.26	0.10	0.23
high value	0.30	0.21	0.29
Average electric rate in 2030 (\$/kW h)			
low value	0.23	0.07	0.17
high value	0.36	0.15	0.23

The economic evaluations included the costs of diesel backup generators for coal and nuclear.

In all cases, the nuclear system will provide the lowest cost power to the consumer. The coal option will beat the diesel option in some scenarios.

### Conclusions and Recommendations

On the basis of environmental permitting, the nuclear plant appears to be a clear winner. Obtaining permits for the coal plant appears to be the most difficult. The validity of this conclusion depends on the process and length of time required to gain a license from the NRC. All assumptions regarding costs and timing require validation.

The economic analysis reveals that the 4S option will provide the lowest cost power if the assumptions hold. In the Galena case, the assumption is that capital cost will be borne by an outside party and that reasonable staffing levels will result from the licensing process. The coal option may be economic in some scenarios compared to enhanced diesel systems, so the coal option should not be entirely dismissed.

Even though installation of the 4S nuclear plant presents a potential long-term solution to Galena's critical energy issues from economic and environmental permitting standpoints, other aspects, such as safety analyses, remain to be performed as part of the licensing process. Ultimately, the selection of the best energy option must consider these analyses and other factors. Specifically, regarding the 4S nuclear plant option, safety relating to potential accidents involving the reactor core and the use of liquid sodium as a heat transfer medium must be adequately addressed. If this technology is successfully deployed in Galena, its economic viability in other Alaska villages and elsewhere depends on the actual life cycle costs yet to be quantified.

## Pre-Publication Draft – Subject to Change

Benefits associated with adoption of one or more of the technologies discussed in this report go beyond their ability to meet Galena's thermal and electric energy loads.

We see the potential for Galena to serve as a training center for rural Alaskans interested in using similar technologies in their villages. We also see the potential for use of additional cogeneration leading to economic development such as the development of horticulture and aquaculture. Enhancement of local employment associated with these activities is another benefit. With today's uncertain energy situation, many communities are diversifying their energy options. This includes adding renewably based technologies to lessen dependence on fossil fuels. Adding a few tens of kW of PV arrays, for example, could help Galena insulate itself against fluctuations in the price and supply of diesel fuel.

Therefore, the recommendations are:

- ◆ Proceed with refining the 4S evaluation process in conjunction with the NRC
  - It may be advantageous for Galena to enlist an independent organization to estimate the time required for licensing and permitting
  - Toshiba and Galena should consider partnering with a U.S. organization or National Laboratory to assist in the process
- ◆ Retain the current diesel systems (with scheduled upgrades) until a decision is made regarding the installation of a replacement by about 2010.
- ◆ Retain the option of a coal mine and power plant until it is determined if the 4S system can be permitted and licensed. If the 4S cannot be realized, then the coal option appears feasible (with a favorable coal resource assessment result).



# Pre-Publication Draft – Subject to Change

## CONTENTS

<b>GALENA ELECTRIC POWER – A SITUATIONAL ANALYSIS.....</b>	<b>ERROR!</b>
BOOKMARK NOT DEFINED.	
<b>EXECUTIVE SUMMARY .....</b>	<b>1</b>
<b>EXECUTIVE SUMMARY .....</b>	<b>1</b>
<b>TABLES .....</b>	<b>19</b>
<b>1. INTRODUCTION .....</b>	<b>22</b>
<b>1.1 Purpose .....</b>	<b>22</b>
<b>1.2 Setting.....</b>	<b>22</b>
<b>1.3 The Galena Situational Analysis Project .....</b>	<b>23</b>
1.3.1 Scope.....	23
1.3.2 Limitations .....	23
<b>1.4 Acknowledgements .....</b>	<b>24</b>
<b>1.5 Advisory Committee .....</b>	<b>24</b>
<b>1.6 Technical Contributors.....</b>	<b>25</b>
<b>2. POWER GENERATION OPTIONS .....</b>	<b>25</b>
<b>2.1 Loads .....</b>	<b>25</b>
2.1.1 Heating Load for Cogenerated Heat.....	25
2.1.2 Electric Loading Profile.....	27
<b>2.2 Enhanced Diesel .....</b>	<b>28</b>
<b>2.3 Coal (Mine &amp; Power Plant).....</b>	<b>30</b>
2.3.1 Coal Mine .....	30
2.3.2 Power Plant with AFBC and a Steam Turbine.....	30
<b>2.3 Toshiba 4S Nuclear Power Plant .....</b>	<b>32</b>
2.3.1 4S System Characteristics .....	32
2.3.2 Safety.....	35
2.3.3 Security .....	36
<b>2.4 Other Power and Heat Generation Modules .....</b>	<b>37</b>
2.4.1 Hydro In-river Turbines .....	37



# Pre-Publication Draft – Subject to Change

2.4.2 Solar .....	38
2.4.2.1 <i>Solar-electric</i> .....	39
2.4.2.2 <i>Solar Thermal</i> .....	39
2.4.3 Biomass .....	39
2.4.4 Wind.....	39
2.4.5 Fuel Cells .....	40
2.5.6 Coal Bed Methane .....	41
<b>3. ENERGY CONSERVATION.....</b>	<b>42</b>
<b>4. USES OF EXTRA POWER .....</b>	<b>42</b>
4.1 District Heating – Sales to Air Station.....	43
4.2 Residential Electric Heating.....	43
4.3 Hydrogen Production .....	44
4.4 Transmission to Other villages.....	46
4.4 Greenhouses and Aquaculture.....	46
4.4.1 Greenhouses .....	47
4.4.2 Aquaculture .....	47
<b>5. ENVIRONMENTAL ISSUES AND PERMITTING.....</b>	<b>48</b>
5.1 Primary Environmental and Permitting Issues.....	48
5.1.1 Disturbance.....	49
5.1.2 Air Pollution.....	49
5.1.3 Water Pollution.....	49
5.1.4 Waste Management.....	50
5.2 Enhanced Diesel .....	50
5.2.1 Background and Assumptions.....	50
5.2.1.1 <i>Disturbance</i> .....	50
5.2.1.2 <i>Air Pollution</i> .....	51
5.2.1.3 <i>Water Pollution</i> .....	51
5.3 Coal .....	51
5.3.1 Background and Assumptions.....	51
5.3.1.1 <i>Coal Mining</i> .....	51
5.3.1.2 <i>Disturbance from Mining</i> .....	52
5.3.1.3 <i>Air Pollution for Coal Mining</i> .....	53
5.3.1.4 <i>Water Pollution for Coal Mining</i> .....	53
5.3.1.5 <i>Waste Management for Coal Mining</i> .....	54
5.3.2 Coal Preparation – Air Pollution.....	54
5.3.3 Coal – Transportation.....	55
5.3.3.1 <i>Federal</i> .....	55
5.3.3.2 <i>State of Alaska</i> .....	56
5.3.3.3 <i>Local</i> .....	56
5.3.4 Coal Power Generation.....	56

## Pre-Publication Draft – Subject to Change

<b>5.4 Toshiba 4S Nuclear Plant.....</b>	<b>56</b>
5.4.1 Disturbance.....	57
5.4.2 Air Pollution.....	57
5.4.3 Water Pollution.....	57
5.4.4 Waste Management.....	57
<b>5.5 Conclusions – Environmental Issues and Permitting .....</b>	<b>57</b>
<b>6. ECONOMIC ANALYSIS .....</b>	<b>58</b>
<b>6.1 Overview of Methodology .....</b>	<b>58</b>
6.1.1 Example of Model Structure.....	58
6.1.2. Economic Model Limitations .....	59
<b>6.2 Assumptions .....</b>	<b>60</b>
6.2.1 Overview of Assumptions and their Use .....	60
6.2.2 Current Loads and System Costs .....	61
6.2.3 Assumptions about Future Loads.....	62
6.2.3 Assumptions about the Diesel System.....	64
6.2.4 Assumptions about the Coal System .....	65
6.2.5 Assumptions about the Nuclear System .....	65
<b>6.3 Economic Analyses Results .....</b>	<b>66</b>
6.3.1 Basic Results.....	66
6.3.1.1 <i>Diesel</i> .....	66
6.3.1.2 <i>Coal</i> .....	67
6.3.1.3 <i>Nuclear</i> .....	69
6.3.1.4 <i>Summary of Basic Results.</i> .....	70
6.3.2 Special Sensitivity Cases .....	71
6.3.2.1 <i>Cases with Nuclear Capital Costs Included</i> .....	71
6.3.2.2 <i>The Effect of Power Plant Location</i> .....	72
6.3.3 Transmission.....	73
6.3.4 Economics of hydrogen production .....	74
<b>7. CONCLUSIONS .....</b>	<b>76</b>
7.1 Economics Conclusions .....	76
7.2 Environmental Issues and Permitting Conclusions .....	78
<b>8. RECOMMENDATIONS .....</b>	<b>78</b>
<b>APPENDIX A. Presentation by Yoshiaki Sakashita, Toshiba, at the 2004 Alaska Rural Energy Conference, April 27-29, 2004, Talkeetna, Alaska .....</b>	<b>81</b>
<b>APPENDIX B. Detailed Discussion of Hydropower, Solar, and Conservation .....</b>	<b>82</b>
<b>APPENDIX C. Summary of Nuclear Regulations.....</b>	<b>88</b>

**Pre-Publication Draft – Subject to Change**

**APPENDIX D. Economic Analysis Model.....94**

**FIGURES**

<b>Figure 2.1.</b> Galena heating load for co-generation.	25
<b>Figure 2.2.</b> Monthly electric generation for Galena.	26
<b>Figure 2.3.</b> Hypothetical electric load for Galena for one year period.	27
<b>Figure 2.4.</b> Hypothetical electric load for Galena for Day 50.	27
<b>Figure 2.5.</b> Performance of DEG system at Galena.	28
<b>Figure 2.6.</b> Schematic of Nuclear Power Plant.	32
<b>Figure 2.7.</b> Schematic diagram of the 4S installation.	33
<b>Figure 2.8.</b> Solar insolation data for Fairbanks, Alaska.	37
<b>Figure 2.9.</b> Map of wind regimes in northern Alaska.	39
<b>Figure 4.1.</b> Energy Trapezoid.	41
<b>Figure 4.2.</b> Heat load for a greenhouse.	46
<b>Figure 6.1.</b> Current cost of electric service with diesel fuel at \$1.32/gal for 2003, the year of this data.	60
<b>Figure 6.2.</b> Projected future energy requirements.	61
<b>Figure 6.3.</b> Projected future electric rates with diesel system.	65
<b>Figure 6.4.</b> Coal plant capacity vs. daily loads for high diesel prices.	65
<b>Figure 6.5.</b> Projected future electric rates with coal system.	66
<b>Figure 6.6.</b> Daily loads vs. nuclear capacity, year 2039.	67
<b>Figure 6.7.</b> Projected future electric rates with nuclear system.	68
<b>Figure 6.8.</b> Projected future electric rates with nuclear capital costs included in rates.	69
<b>Figure B.1.</b> An active solar closed-loop water heating system.	82

## Pre-Publication Draft – Subject to Change

### TABLES

<b>Table 2.1.</b> Key parameters for four Alaska coal-power plant studies.	31
<b>Table 4.1.</b> Equivalent liquid hydrogen needed to displace local petroleum based fuels.	44
<b>Table 4.2.</b> Results of hydrogen economic analysis.	44
<b>Table 4.3.</b> Cost of installing a transmission line to serve near-by villages.	45
<b>Table 5.1.</b> Partial list of permitting requirements related to disturbance of lands and waters.	47
<b>Table 5.2</b> Usibelli Coal Preparation Plant Source Inventory.	53
<b>Table 6.1.</b> Summary of critical assumptions.	59
<b>Table 6.2.</b> Galena electric utility statistics.	59
<b>Table 6.3.</b> Future energy requirements.	60
<b>Table 6.4.</b> Assumptions about heating loads.	62
<b>Table 6.5.</b> Assumptions about the diesel system.	62
<b>Table 6.6.</b> Assumptions about the coal system.	63
<b>Table 6.7.</b> Assumptions about the nuclear system.	64
<b>Table 6.8.</b> Summary of basic results.	68
<b>Table 6.9.</b> Economic costs and benefits of transmission lines.	71
<b>Table 6.10.</b> Hydrogen enterprise analysis.	72
<b>Table 7.1.</b> Summary of basic cases and sensitivity cases.	74
<b>Table C.1.</b> NRC Regulatory Guides - Environmental Siting (Division 4).	88
<b>Table D.1.</b> Parameters and Assumptions for Economic Analyses.	91
<b>Table D.2.</b> Diesel-Only Power Supply Economic Analysis.	93
<b>Table D.3.</b> Coal Power Supply Economic Analysis.	94
<b>Table D.4.</b> Nuclear Power Supply Economic Analysis.	96

## Pre-Publication Draft – Subject to Change

### ACRONYMS AND ABBREVIATIONS

ACMCRA	Alaska Surface Coal Mining Control and Reclamation Act
AFBC	atmospheric fluidized bed combustor
AVEC	Alaska Village Electric Cooperative
B	billion
Btu	British thermal unit
CGP	Construction General Permit
CFR	Code of Federal Regulations
CTLoad	cogeneration thermal load
DEG	Diesel Electric Generator
DEC	Alaska Department of Environmental Conservation
DOE	U.S. Department of Energy
DNR	Alaska Department of Natural Resources
DMLW	DNR Division of Mining, Land and Water Management
EPA	U.S. Environmental Protection Agency
Gal	gallon
GVEA	Golden Valley Electric Association
HDD	heating degree day
HDH	heating degree hour
HHL	hourly heat load
INEEL	Idaho National Engineering and Environmental Laboratory
K	thousand
kW	kilo-watt
kWh	kilo-watt hour
kWp	kilo-watt peak
M	million
MW	mega-watt
MWh	mega-watt hour
NRC	Nuclear Regulatory Commission
SIR	small innovative reactor
SMCRA	Surface Mining Control and Reclamation Act of 1977
NETL	National Energy Technology Laboratory
NPDES	National Pollutant Discharge Elimination Permit
NREL	National Renewable Energy Laboratory
MSW	municipal solid waste
PAFC	phosphoric acid fuel cell
PEM	proton exchange membrane
RCRA	Resource Conservation and Recovery Act
SMCRA	Surface Mining Control and Reclamation Act



# Pre-Publication Draft – Subject to Change

## 1. INTRODUCTION

### 1.1 Purpose

The purpose of the investigation is to compare the future power generation options available to the City of Galena. The cost for power (\$/kWh) is the parameter used as the basis for this comparison.

Galena's electric utility currently generates power using internal combustion diesel engines and generator sets (DEG). An exposed coal seam nearby might provide fuel for a power plant. The City has been approached by Toshiba, Inc., as a demonstration site for a small 10-MW (Model 4S) nuclear reactor power plant. The Yukon River is possibly a site for in-river turbines for hydroelectric power. Additional contributions to the energy mix might come from solar, municipal solid waste, or wood. This report summarizes the comparative economics of various energy supply options.

This report will first discuss;

- thermal and electric load profiles for Galena
- technologies and resources available to meet or exceed those loads
- uses for any extra power produced by these options
- environmental and permitting issues and
- the overall economics of them.

The bottom-line conclusions will compare the consumer cost of power on a \$/kWh basis.

### 1.2 Setting

The City of Galena is a community of about 800 people situated on the north shore of the Yukon River in the interior of Alaska 270 air miles from Fairbanks. Galena experiences a cold continental climate with extreme temperature differences (-64 to 92 °F). Temperatures of -40° F are common during the winter. Annual precipitation is 12.7 inches, with 60 inches of snowfall. The River is ice-free from mid-May through mid-October. The climate is important to power use projections. For more information, see the State's community information web site for Galena; ([www.dced.state.ak.us/dca/commdb/CB.cfm](http://www.dced.state.ak.us/dca/commdb/CB.cfm))

The City has three distinct districts: "Old Town," "New Town," and the Air Station. The community was formerly established in 1918 near an Athabaskan fish camp (Henry's Point) and became a supply and transshipment point for nearby lead mines. In 1920, Athabascans from the village of Loudon began moving to Galena to find employment selling wood to steam ships and hauling freight to the regional mines. The Galena airfield was established during World War II as a refueling point for planes being ferried to Russia as part of military operations (Lend-Lease Program). During the 1950s the military installations were expanded. Due to a severe flood in 1971, a new community site was developed 1 ½ miles east of the original town site. "New Town" is the site of the City offices, health clinic, schools, washeteria, store, and more than 150 homes. The Air Force Station was closed in 1993. It is maintained by the Chugach Development Corporation and is used as a backup Air National Guard facility. It is also



## **Pre-Publication Draft – Subject to Change**

the site of Galena School District Boarding School and Vocational Training programs. ([www.dced.state.ak.us/dca/commdb/CB.cfm](http://www.dced.state.ak.us/dca/commdb/CB.cfm)).

Galena's current energy requirements are met by DEG-produced electricity, fuel oil-fired boilers, and oil- or wood-fired stoves. All economic analyses will compare considered options to those currently in widespread use.

### **1.3 The Galena Situational Analysis Project**

#### **1.3.1 Scope**

The project scope is to assess the electric power generation/distribution options and compare their economics for the City of Galena. Conceptual plant designs from previous investigations were used. Current loads and projected uses for energy were considered in developing the projections. The final product is the comparison of consumer electric rates projected through a 30-year period (2010 through 2039).

Key issues to be addressed in choosing future energy options for any community include (1) available resources, (2) loads [electrical and thermal], (3) suitable technologies, (4) uses for extra power, (5) environmental and permitting issues and (6) economics. Uncertainties in the future price of imported fuel underlie all economic calculations. Additional considerations are possible linkages with neighboring villages and the potential for economic stimulation are presented in appropriate sections.

The Project Team visited the City twice. The first visit was April 1 and 2, 2004, to kick off the project, gather background information, and make presentations at both a town meeting and at the "Breakfast Club." During the second visit, June 15-16, presentations of our preliminary results were made to the City Council (in open meeting), at the "Breakfast Club," and to the staff of the Loudon Tribal Council. During these visits, options were discussed with many and we gained valuable insight and information.

#### **1.3.2 Limitations**

An investigation of this type has several constraints placed on it by time, resources, and the availability of data. Limitations specific to this project include:

- Coal resource data for the Loudon deposit is limited, therefore it was assumed to be sufficient to support the coal mine and power plant option. Detailed resource evaluation is needed.
- Detailed designs for power plants for the various fuel options, heat transfer systems, and extra power-use facilities were outside the scope of this project. Previous work cited was used for this analysis.
- The use of the Toshiba 4S reactor system will require extensive technical design, operations, safety, risk, and environmental analyses. The results of these analyses will determine the feasibility of the installation.
- The economic analysis is based on the comparison of scenarios for change occurring 30 years into the future. While scenario analysis is a useful tool for examining long-range feasibility, it does have several limitations.

## Pre-Publication Draft – Subject to Change

- First, the validity of the analysis depends on the validity of the scenarios and the assumptions that are used to generate the scenarios.
- Second, the analytical model does not contain internal "feedbacks" such as an explicit link between higher electricity prices and reduced electricity consumption.
- Third, we have not attached probabilities to any of the assumptions or scenarios. Therefore the model cannot produce estimates of a single "most likely" or "best" estimate for any of the results.
- Finally, no attempt has been made to explicitly evaluate the degree to which any of the options may increase or decrease economic and financial risk. In summary, our scenario-based analysis requires readers of the report to make their own judgments about which scenarios and assumptions are more likely to occur. Although this can be viewed as a limitation of our method, it can also be viewed as a strength, since there is a clear link between assumptions and conclusions for each scenario examined.

Another uncertainty is the magnitude of any future carbon or other emissions taxes. Even a modest carbon tax such as that being proposed in some European countries can have a significant effect on the costs of using fossil fuels – in this study, the tax would have application in all options because either they are based on fossil fuels (coal and enhanced diesel) or employ diesel generation as a backup (coal and nuclear).

### 1.4 Acknowledgements

This study was conducted over a three-month period beginning in April 2004. Funding was provided by the U.S. Department of Energy's Arctic Energy Office. Assistance and support was received from many sources. Specifically, the authors thank: the members of the Advisory Committee (See Section 1.5) for input and guidance; the Galena City Council, City Manager, and "The Breakfast Club" for important background and operational information; the Loudon Tribal Council for insight into its perspective on development; the citizens of Galena for their hospitality; the Alaska Village Electric Cooperative (AVEC) for providing electric load data; and vendors of related systems and products for helping us understand system possibilities; and Ashish Agrawal of UAF for helping with the electric load calculations

### 1.5 Advisory Committee

An Advisory Committee was formed to review the project plans and progress through the study. The primary functions of the committee were to make sure the most critical issues were addressed and that reasonable assumptions were made. The Advisory Committee met on April 22, 2004, June 8, 2004, and July 21, 2004. The Committee members are

Peter Crimp, Alaska Energy Authority  
Brent Petrie, AVEC  
Kathy Prentki, Denali Commission  
Tyg Skywatcher, Loudon Tribal Council

# Pre-Publication Draft – Subject to Change

Marvin Yoder, City Manager, City of Galena

## 1.6 Technical Contributors

Robert E. Chaney, Project Manager, SAIC Corporation, Anchorage, Alaska

Stephen G. Colt, Assistant Professor, University of Alaska Anchorage, Anchorage, Alaska

Ronald A. Johnson, Professor, University of Alaska Fairbanks, Fairbanks, Alaska

Richard W. Wies, Assistant Professor, University of Alaska Fairbanks, Fairbanks, Alaska

Gregory J. White, Consulting Scientist, Idaho National Engineering & Environmental Laboratory, Idaho Falls, Idaho

## 2. POWER GENERATION OPTIONS

Essential in determining the most appropriate power generation options to consider is an understanding of the community's loads. After loads are assessed, then options are considered.

Note that for any system option, there is a requirement to provide for backup generation capacity, which is accomplished by retaining some level of diesel generation capacity.

### 2.1 Loads

#### 2.1.1 Heating Load for Cogenerated Heat

Currently, the city buildings, school, swimming pool and health clinic space heating needs are met by capturing the heat rejected by the diesel electric generators (DEGs) and transferring the hot water to the buildings (all close to the power plant). We have assumed a existing average cogeneration load of 400,000 Btu/hr for eight months per year plus an 300,000 Btu/hr [commercial/residential boiler load] for other buildings in town for eight months. This gives a total yearly cogeneration thermal load [CTLoad] projected for the future of about 4 B Btu. The 400,000 and 300,000 Btu/hr were obtained from the 2004 Galena Energy Assessment (Northern Resource Group, 2004). These were distributed over a year using Fairbanks heating degree days [HDD] data. This gives a maximum heating load of 900,000 BTU/hr. However, in his response to the Denali Commission Screening Report (Northern Economics, 2001), city manager Marvin Yoder said the city uses 50% of DEGs BTUs in winter. With an average load of ~ 900 kW in winter, we can assume the heat rejected to the jacket water is ~900 kW. Using half of this results in 450 kW ~ 1.5 mm Btu/hr as the maximum cogenerated heat delivered. Allowing for expansion, the maximum cogenerated heat delivered is about 1.8 M Btu/hr. This results in the upper curve in the plot shown in **Figure 2.1** below and a

## Pre-Publication Draft – Subject to Change

yearly total of about 8 B Btu.

These HDDs were found using 1958 to 1993 data for the average daily temperature in Fairbanks and noting that each English unit HDD is 24 hours with the average ambient temperature 1°F below 65°F. A curve fit for average daily temperature was used.

$$T = 27.5 + 36 \cdot \sin(\pi \cdot (d-96)/182) \quad \text{where day [d] 0 is on Jan 1.}$$

The minimum of this plot occurs on Jan 5.

Then  $HDD = (65 - T)$  gives the distribution of HDD over the year. The corresponding equation for heating degree hours [HDH] is

$$HDH = 65 - T1 \quad \text{where}$$

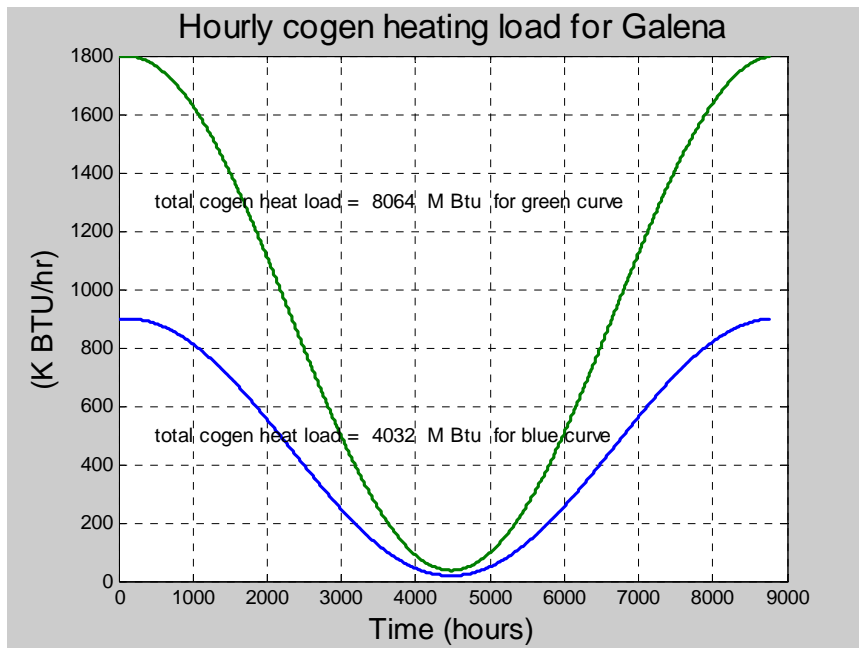
$$T1 = 27.5 + 36 \cdot \sin(\pi \cdot (hr/24-96)/182).$$

Using  $HDH_{total} = \sum(HDH)$ , one can calculate the hourly heat load (HHL),

$$HHL = CT_{Load} \cdot HDH / HDH_{total}$$

This results in curves shown in **Figure 2.1**, below. The yearly total HDD resulting from this curve fit is 13793, which is the average for the 35 years beginning in 1958.

Note: The Fairbanks average monthly minimum and maximum T over the 11-year period beginning with 1980 correlated with Tanana with an  $R^2 > 0.99$ . Since Tanana is 100 miles upriver from Galena, using Fairbanks temperature data to produce HDD is a good approximation for Galena.

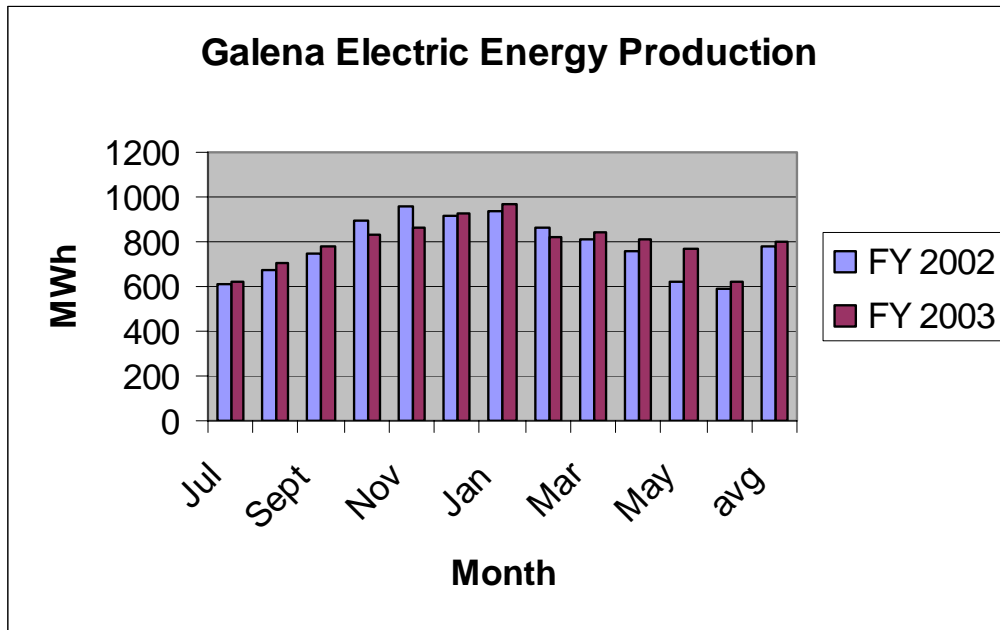


## Pre-Publication Draft – Subject to Change

**Figure 2.1.** Galena heating load for cogeneration

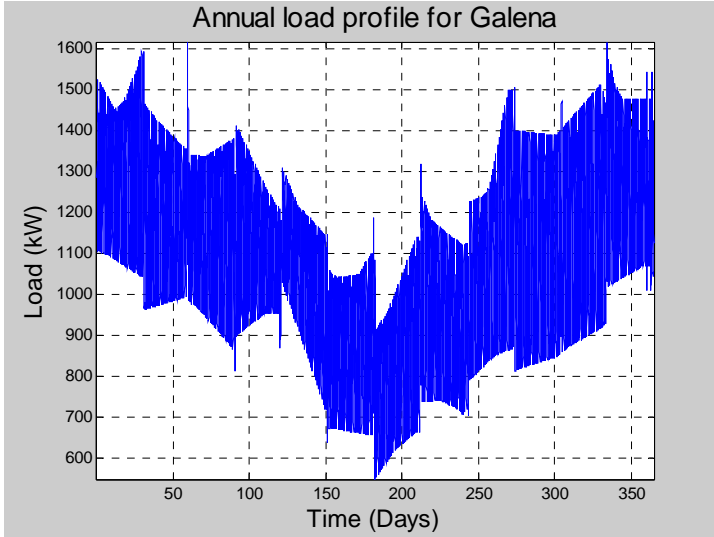
### 2.1.2 Electric Loading Profile.

To generate an electric load profile with data at 15-minute intervals for Galena, we started with the actual data for monthly kWh generated [Galena Energy Assessment, 2004], the data for winter and summer peaks from the Denali Commission Screening Report (Northern Economics, 2001) [1.6 MW and 0.9 MW], and used 15-minute load information from an interior Alaska Village Electric Cooperative (AVEC) village (Petrie, 2004) with a similar climate to provide profiles for diurnal and weekly variations for Galena. These 15-minute data were comparable with 1-hour data collected in Galena for the 1<sup>st</sup> quarter of 2004. In **Figure 2.2**, we see the monthly electric energy generated. This results in an annual load slightly under 10 M kWh. The average monthly load was about 800 kW in July and over 1 MW in January.

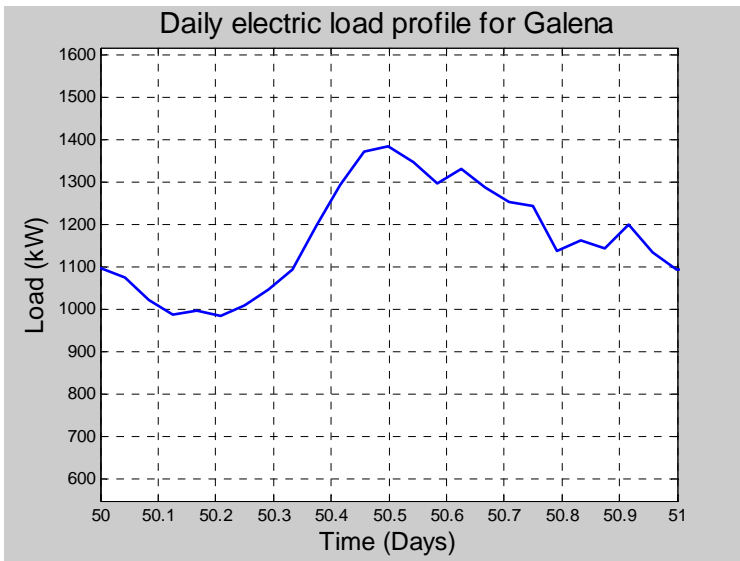


**Figure 2.2.** Monthly electric generation for Galena

By scaling the data for a northern AVEC village, we generated a map of yearly load excursions for Galena such that the yearly and monthly totals match the actual Galena data. The results are shown in **Figure 2.3**. Here, if we zoomed in on, for example, a 1- or 2-day time period, we would see the details of the loads for that particular period with the load being greater at 6 p.m. than 2 a.m. Such details can be extracted from the MATLAB<sup>TM</sup> program used to generate this plot and are shown in **Figure 2.4**.



**Figure 2.3.** Hypothetical electric load for Galena for one-year period



**Figure 2.4.** Hypothetical electric load for Galena for Day 50. The maximum is 1380 kW and the minimum is 990 kW.

## 2.2 Enhanced Diesel

According to the Rural Alaska Energy Plan (MAFA, 2002a), the most efficient village-sized DEGs available today are capable of achieving peak efficiencies in the 15.8 kWh/gal range. With a fuel oil having a heating value of 135 K Btu/gal, this is equivalent to converting 40% of the energy in the fuel to electric power. Technology improvements such as those associated with electronic fuel injection have reduced air pollution and noise due to more efficient combustion processes. The enhanced diesel scenario will assume an efficiency, for electric power production, of 15 kWh/gal as long as each

## Pre-Publication Draft – Subject to Change

generator operating is at least 50% load. At the same time, we will assume that the captured heat from the jacket water and after-cooler [if applicable] is at least 50% of the electric power output.

We also estimate the cogenerated heat available in the jacket water is in the range of the electric power generated. Hence, the difference between these two will be proportional to the parasitic fan power needed for heat rejection when cogeneration is not sufficient for heat rejection requirements.

We can define three kinds of efficiency with

$$(1) \eta_{el} = W_{el}/Q_{doth}$$

$$(2) \eta_{cogen} = [W_{el} + Q_{dotcogen}]/Q_{doth}, \text{ and}$$

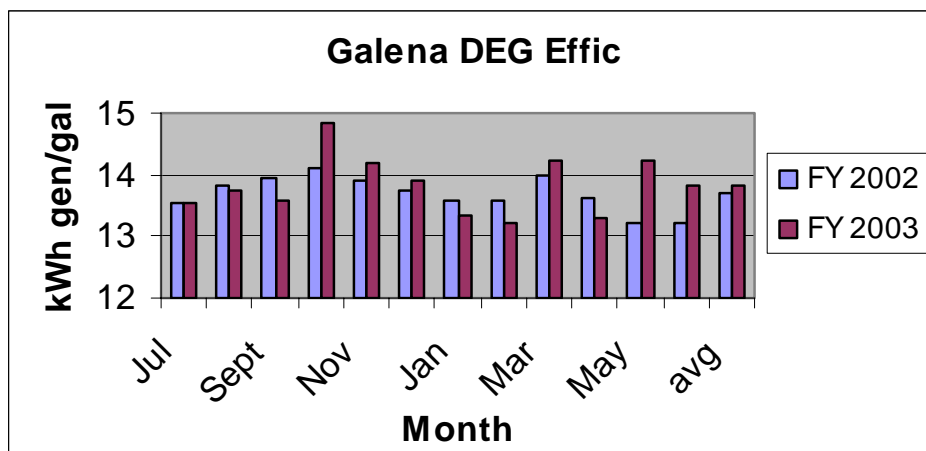
$$(3) \eta_{econ} = [W_{el} + \alpha Q_{dotcogen}]/Q_{doth}$$

where  $W_{el}$  = the electric power produced (kW)  
 $Q_{doth}$  = the rate of energy input in the fuel (kW)  
 $Q_{dotcogen}$  = the heat recovery rate (kW), and  
 $\alpha$  = an energy quality factor

$\alpha$  accounts for the lower quality of thermal compared with electric energy. An approximate figure for  $\alpha$  may be 1/3.

Note: to convert heat rate into units associated with electric power, it is convenient to use  $1 \text{ kW} = 3,412 \text{ Btu/hr}$ .

**Figure 2.5** shows that the average monthly electrical generation efficiency varies from about 13.2 to 14.8 kWh/gal with an average of 13.76. If we assume the fuel has a heating value of 134K Btu/gal and uses  $1 \text{ kWh} = 3,412 \text{ Btu}$ , the above corresponds to an actual Galena efficiency range of 33.5 to 37.6%. If we assume we can capture heat equivalent to one-half  $W_{el}$ , then each of these efficiencies increases by 50% according to Equation (2). From Equation (3), if  $\alpha = 1/3$ , each  $\eta$  increases by about 17%.



**Figure 2.5.** Performance of DEG system at Galena

## Pre-Publication Draft – Subject to Change

By assuming enhanced utilization of cogenerated heat together with more efficient production of electric power, we can calculate the reduction in diesel fuel used annually compared with a baseline case. By amortizing the cost of buying new improved diesels and expanding district heating, we can calculate if the benefit cost ratio is greater than one.

### 2.3 Coal (Mine & Power Plant)

#### 2.3.1 Coal Mine

An exposed coal seam about 18 road miles upriver from Galena has coal having an estimated heating value averaging 9.4 K Btu/lb (18.6 M Btu/ton). Its sulfur content is less than 0.5%, ash averages 9% [range 2 to 16%], and moisture content averages 19% [14 to 28%]. One exposed seam is about 9 feet high and 2,000 feet across. [Phillips and Denton, 1990]. If a 1-MW coal-fired plant were to operate with an efficiency of 25%, it would require 13.6 Btu/hr of fuel energy or about 0.68 tons/hr (6,000 tons/yr) of coal. At a density of ~ 80 lb/ft<sup>3</sup>, the required volume is about 17 ft<sup>3</sup>/hr or 12K ft<sup>3</sup>/month. If a 100-foot width were taken from this 9-foot-high coal seam and used, 13 ft/month or 166 feet/yr would have to be excavated.

The coal resource estimate was based only on the extent of the exposed seams. A detailed drilling program is required to delineate and define the magnitude of the coal resource contained in this bed.

A cost estimation for hauling 5K tons/yr of coal 10 miles is \$123/ton for a “model” mine with \$35 of this for hauling, \$35 for permitting and engineering, and \$25 for stripping (Phillips and Denton, 1990). This is slightly lower than the \$128/ton estimate for coal delivered from the Loudon prospect to Galena (Northern Economics, 2001).

#### 2.3.2 Power Plant with AFBC and a Steam Turbine

Atmospheric fluidized-bed combustion (AFBC) boilers are now well-established as a mature power generation technology with more than 620 AFBC units in operation worldwide in the size range 20 to 300 megawatts (MW). Current operating experience shows that AFBC boilers meet high environmental standards and are commercially viable and economically attractive.

<http://www.epri.com/journal/details.asp?id=627&doctype=features>

Two commercial units are operating in Ohio at sizes < 5 MW. One (Johnson) unit has operated for about 20 years. A DOE-supported 8.5 M Btu/hr unit at Cedar Farms, Ohio, has completed four months of unattended computer operation of the combustor by April 2004. Furthermore, it received certification for long-term commercial operation from Ohio having met emissions requirements for sulfur and particulates. It provides hot water at 14 psia and 185°F for a commercial greenhouse operation. Since the greenhouse now operates with natural gas (NG) costing \$8.30/MBtu, the payback period is about four years accounting for combustor's the installed cost. This period is estimated to be six years if this unit were modified to produce electric power (Bonk, 2004). To do this, a turbine/generator, more heat transfer area, plus auxiliary equipment



## Pre-Publication Draft – Subject to Change

must be added. The latter would include additional controls as well as transformers and a distribution system.

These plants burn a range of fuels, including bituminous and subbituminous coal, coal waste, lignite, petroleum coke, biomass, and a variety of waste fuels. In many instances, units are designed to fire several fuels, which emphasizes one of the technology's major advantages: its inherent fuel flexibility. AFBC boilers also can more readily handle fuels that are problematic in pulverized coal (PC) boilers (i.e., biomass and waste). The principle of operation involves tiny particles of combustible material such as coal being kept in suspension by upward flowing air. The bed of hot coals surrounds water-filled tubes to which heat is very efficiently transferred to make steam. The steam expands through a steam turbine that is coupled to an electric generator to produce electric power.

The U.S. DOE initiated a study in 1998 (Northern Economics, 2001) to investigate the capital and operating costs of small coal-fired power plants [600 kW to 2 MW]. For 50 and 85% load factors, fuel costs ranging from \$2.25 to \$12.00/MBtu, and efficiencies from 20 to 26 K Btu/kWh, the electricity costs ranged from \$0.22 to \$0.77/kWh. The installed costs ranged from \$3.0K to \$4.3K/kW and the total annual non-fuel costs ranged from \$1.0M to \$2.6M. Galena coal was mentioned to have a delivered cost of \$7.06/MBtu in that report. This is close to the \$6.15/M Btu derived from the 1990 study cited above. At the other end of the spectrum, the Royal Academy of Engineering (2004) calculated the electricity costs from large [ >100 MW] coal-fired CFB power plants to be \$0.063/kWh with about 90% of that being approximately equally distributed among fuel, capital, and carbon emissions. These costs were slightly lower than those for plants using pulverized coal.

A 2003 feasibility study on a barge-mounted 5-MW AFBC power plant (Bonk, 2004) estimated capital costs from \$20M to \$25M and electricity costs of \$0.20/kWh minus a credit for heat delivered. This is for 11K Btu/lb coal delivered for \$100/ton [estimates for Galena]. These last two numbers are equivalent to \$4.54/MBtu delivered cost.

J.S. Strandberg (1997) did a feasibility analysis of an 800 kW AFBC coal plant in McGrath, Alaska, plus a 125 kW DEG. He estimated a total project budget of about \$14 million, which included the power plant, coal mine development, haul road, and an expanded district heating system. The coal had a heating value of about 6700 Btu/lb and was assumed to cost \$52/ton delivered. The district net output was 9 M Btu/hr and water was supplied at 240°F and 75 psig. The estimated electricity cost was \$0.176/kWh, which included a \$ 0.077/kWh credit for heat delivered. Over half of the total cost was for coal and limestone. A major issue was the system's high parasitic power required [over 155 kW], and the estimate for it was increased as the study was completed.

Phillips and Denton (1900) calculated costs for a 483 kW coal-fired model cogeneration facility producing 6.8 M Btu/hr of heat. The costs of electricity ranged from \$0.11 to \$0.22/kWh for a base load plant to as much as \$0.80/kWh for a lightly loaded plant. The corresponding heat costs ranged from \$16 - \$28/M Btu on the low end to as much as \$110 on the high. Of the 21 M Btu/hr fuel input, 46% went to the production of electricity. Of the total capital cost of \$7.5 M, \$2.0 M was allocated to electrical and

## Pre-Publication Draft – Subject to Change

>\$5.5 M to heat. Almost half of the latter was for 12,000 feet of distribution piping at \$200/ft. For a plant in Galena using Louden coal, the electricity costs were estimated to range from \$0.26 to \$0.36/kWh and heat from \$24 to \$36/M Btu.

A comparison of the four Alaskan studies appears in **Table 2.1**.

**Table 2.1.** Key parameters for four Alaska coal-power plant studies

Study/Parameters	Size for We	Capital Cost	Est. Rate (\$/kWh)
Phillips & Denton, 1990	483 kW + 6.8 M Btu/hr heat	\$ 7.5 M [\$ 2M for elec. Rest for heat	0.11 to 0.80 [base load to lightly loaded
USDOE, 1998	600 kW to 2 MW	\$ 2.5 .. \$ 6M	0.22 to 0.77 [various fuel costs & loading]
Strandberg, 1997	800 kW + 9 M Btu/hr heat	\$ 14M [including coal mine + district heat]	0.18
Bonk, 2004	5 MW [barge mounted]	\$ 20 - \$25 M	0.20

For comparison, according to Colt et al. (2001), the true cost of rural electric utility service for 90% of rural Alaska villages runs less than \$0.45/kWh. The range is from \$0.17/kWh for larger regional center communities (Naknek) up to around \$1.80/kWh for small remote communities like Pedro Bay.

A coal fired-plant should be a base-load plant sized to run near its capacity all the time except for planned shutdowns for maintenance and repair.

## 2.3 Toshiba 4S Nuclear Power Plant

### 2.3.1 4S System Characteristics

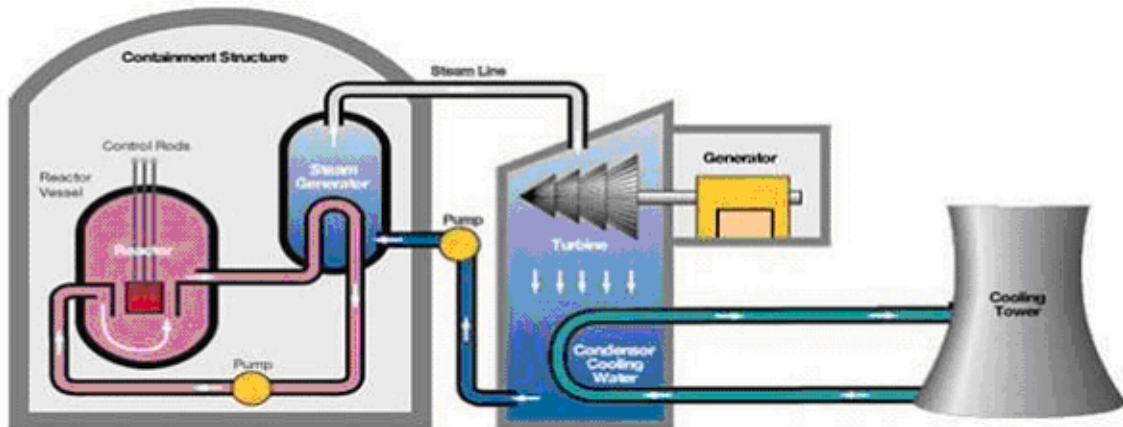
This discussion of the proposed nuclear reactor is a summary and more details are enclosed in the Appendices. First, the characteristics of the design are presented. Then, sections are included describing the safety of the design and the security issues.

The nuclear reaction which occurs in the reactor core produces heat. This heat is conveyed by heat transfer fluids or coolants to the exterior of the reactor where the energy is used for electric power generation or for other purposes. Existing commercial plants in the United States employ water as the coolant and produce hot pressurized water from the energy released by radioactive decay in the nuclear core contained within a pressure vessel. This water, in turn, transfers heat to water in the secondary water system to vaporize it into steam. All this occurs within a thick concrete containment structure. The pressurized steam is transferred outside the containment vessel where it drives a steam turbine coupled to an electrical generator. Control rods in the core are used to moderate the reaction. Currently, the United States produces about 17% of its electricity from 109 nuclear power plants of up to 1000 MW capacity. Worldwide, there are over 400 nuclear plants; France generates 77% of its electricity from nuclear

## Pre-Publication Draft – Subject to Change

reactors . There are no commercial nuclear power plants in Alaska (McKinney and Schoch, 1998)

**Figure 2.6** shows the large containment structure in which the reactor and steam generator are housed. Note the parabolic-shaped cooling tower in which water is sprayed to allow heat to be rejected to the ambient air. This heat rejection provides a heat sink to condense the steam leaving the turbine. The pump feeding the working fluid to the steam generator requires water in the liquid form to work effectively. Hence, the steam must be condensed upstream of the pump. The pump pressurizes the water to allow proper operation of the pressurized water reactor.



**Figure 2.6.** Schematic of Nuclear Power Plant: Photo courtesy of TVA

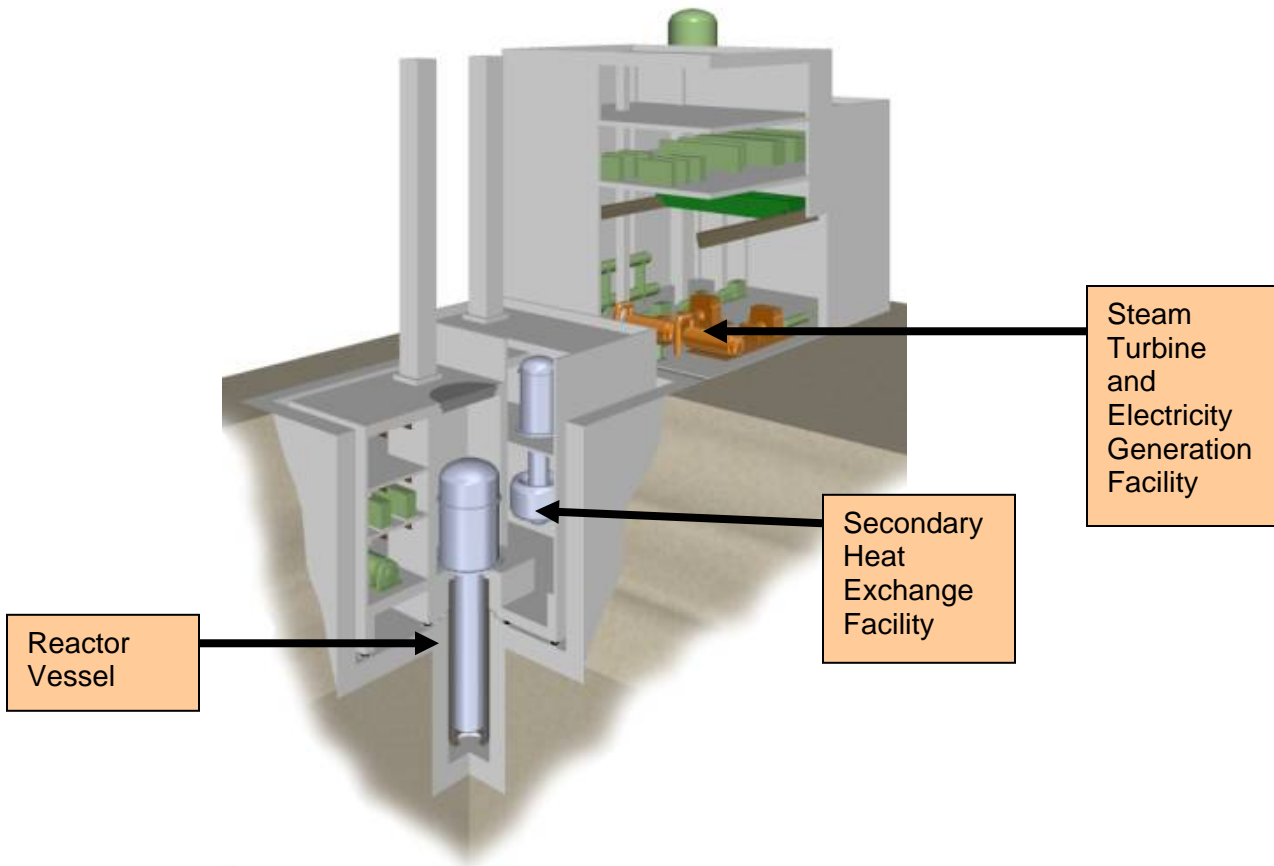
The 10 MW Toshiba 4 S nuclear power plant is an example of new small innovative reactor [SIR] designs that are under active development today. Most of the components of this system have been extensively tested and many have been licensed by the Nuclear Regulatory Commission (NRC). Toshiba currently is conducting engineering work to complete the reactor and plant designs. Therefore, if the first operational unit is installed at a site such as Galena, it would be considered a “reference” rather than a “prototype” or “demonstration” plant. Reactor development proceeds in several steps.

- *Experimental* reactors are the first stage to test the concept (research)
- *Demonstration* reactors use refined designs and test integrated systems (engineering)
- *Prototype* reactors are the first of several reactors of the fully engineered design
- *Reference* plants establish the design basis for licensing and serve as a model for the construction and licensing of additional commercial plants. (Rosinski, May 24, 2004, private communication)

The assumption that the 4S would be a reference plant is subject to some question by U.S. National Laboratory staff (Brown, 2004, Sackett, 2004). Further, caution should be taken in the estimated development time needed to bring this design to an operational state. In this study we assumed the plant would be ready in 2010, but it may require 3 to 5 years longer.

## Pre-Publication Draft – Subject to Change

The 4S is schematically shown in **Figure 2.7**. These modular reactors are designed to require minimum field assembly and minimal maintenance by allowing spent or defective modules to be removed and repaired at a central facility. Unlike commercial power reactors, the 4S is designed as a totally enclosed unit. The core and the primary coolant loops are sealed in the cylindrical structure. The heat released by the fission process and radioactive decay in the core is transferred to a liquid metal [sodium] in a primary heating loop. This, in turn, heats sodium in a secondary loop that transfers heat to water to make steam in a second heat exchanger which in turn drives a steam generator. The sodium is maintained at about 1 atmosphere pressure and 500°C. There is no design capability to open the reactor vessel, for any purpose, other than at the factory. The coolant is circulated by electromagnetic pumps which have no moving parts. Coolant pumps and reservoirs are located above the core so that the structure design is kept long and narrow. This design also means that there are no emissions, except steam, throughout the lifetime of the plant.



Toshiba, Inc.

**Figure 2.7.** Schematic diagram of the 4S installation. Note that it is proposed that the Reactor Vessel be installed up to 100 feet below grade.

In the 4S design, the radioactive core is 2.0 m high and 0.7 m in diameter with the fuel composition of enriched uranium alloyed with zirconium. The fuel is less than 20% uranium. A cylindrical steel reflector shield rising from the bottom at a rate of around 5 cm/yr by means of an electromagnetic drive mechanism maintains the proper

## Pre-Publication Draft – Subject to Change

reaction rate by reflecting neutrons back into the core. The reflectors are moving upward slowly in order to compensate the reactivity loss during 30 years burn-up. In the event of a shutdown for whatever reason, gravity will cause the shield to fall back down, slowing the reaction rate. Moreover, the reactivity temperature coefficient is negative, meaning that the reaction will slow down if the core temperature gets too high. If an accident occurred, power would be lost, the reflector would stop its ascent, and it would move down to make core sub-critical, terminating the fission reaction.

The projected design life of the sealed 4S reactor is 30 years. The intent is that refueling on site would not be necessary. The reactor is intended to be returned to the factory and a replacement unit installed at the end of the unit's life. For a first-of-a-kind installation in Galena, licensing requirements may include extensive analysis of the reactor after a short run-time (i.e. 1 to 5 years). In this case the reactor would be changed out at that interval and returned to Toshiba for analysis.<sup>3</sup> Extensive technical design evaluations are underway at Argonne National Laboratory – West, in conjunction with Toshiba, to improve and refine features of the 4S, but the current design is a sound basic design with low technical risk. (Sackett, 2004)

Load following is achieved by controlling the water flow to the steam generator causing changes in the coolant temperature, which affects the core inlet temperature and hence alters the reaction rates in the core. Since the core reactivity has a negative temperature coefficient, the lower water flow rate [lower load] lowers the core thermal output [consistent with lower load] by raising the core temperature. This feature greatly simplifies operation of the 4S power plant. (USDOE, 2001)

A cost estimate provided by Toshiba in 2003 was a capital of \$2,500/kWe and electricity at \$0.05 to \$0.07/kWh assuming mass production of such plants. Experts may assert that this is a low value and does not include all of the development costs, as noted above. (Brown, 2004, Sackett, 2004)

Prior to the installation of any nuclear plant in the US, the Nuclear Regulatory Commission (NRC) conducts an extensive licensing process. This process includes extensive safety, security, and siting reviews. Detailed risk assessments are required; Safety and Security are critical elements of the process. The time required is not known precisely at this time.

### 2.3.2 Safety

The 4S is a pool type of reactor – not a breeder reactor- that has an “inherently” safe design so that it shuts itself down if coolant is lost. If that occurs, the reflector falls to the bottom of the reactor vessel, no longer performing its function, and the nuclear reaction slows down. This has been tested in the laboratory and will be verified as part of the Toshiba development work prior to NRC licensing and approval. The concept was also demonstrated at the Experimental Breeder Reactor II (EBR II) at the Argonne National Laboratory-West facility at the Idaho National Engineering Laboratory in 1988 when a large-scale reactor of this design was tested to failure, and the tests proved the reactor would shut down with no adverse effects.

---

<sup>3</sup> According to Toshiba, this location would probably be the same as that for final reactor assembly.

## Pre-Publication Draft – Subject to Change

The fact that there are no moving parts in the vessel adds to safety of the plant. The coolant is pumped using the electromagnetic properties of the sodium. Designed so that there is no refueling during its design-life, the 4S requires very low maintenance and reduces the risk of mechanical failure.

The possibility of sodium-water reactions is a serious consideration, and concerns about handling of sodium have resulted in extensive design consideration of the coolant loops in the 4S. Water and sodium react with the release of a large amount of energy, and the 4S is consequently designed with double-walled piping to contain the sodium and prevent leaks (Sakashita, 2004). Advanced leak detection systems sense the void between the walls of the pipe for sodium vapor. If detected at levels of 0.1 gram per second, the sodium circulation system is shut down. This contains the sodium within the piping, which is in turn contained inside the vessel or the secondary cooling loop housing. In the event of a leak, there are double and triple containment features. Leak detection systems monitor for sodium in each of the containment areas. This significantly reduces the risk of leaked sodium coming in contact with water.

Sodium cooled reactors throughout the world have been run for thousands of hours without incidents involving the reactor core. According to Neil Brown, a nuclear engineer at the Lawrence Livermore National Laboratory, there are 21 sodium-cooled fast reactors worldwide, including Japan's MONJU. This 280-MW plant operated for about one year starting in 1994 before being shut down after an accidental sodium leak and fire. No radioactivity leaked, but community concerns have kept MONJU shut down. (FDNM, 2004).

Another example of long-term operation is a 140-MW liquid metal reactor (JOYO), which has operated in Japan since 1977. It is a breeder reactor designed to produce more fuel than it consumes. It had operated for over 50,000 hours by the time it was shut down in 1994 and produced over 4,000,000 MWh of thermal energy.

[http://www.iaea.org/inis/aws/fnss/fulltext/0791\\_4.pdf](http://www.iaea.org/inis/aws/fnss/fulltext/0791_4.pdf)

During a period when the reactor was shut down, there was a fire lasting 3 hours in a maintenance facility 50m from the reactor in Oct. 2001. The fire may have been caused by spontaneous combustion of sodium on some of the equipment (Japan Times, Nov. 2, 2001).

In another example of long-term operation, the Experimental Breeder Reactor-II (EBR-II) generated over 2 B kWh of electricity while operating at Argonne National Laboratory from 1964 to 1994.

[http://www.anlw.anl.gov/anlw\\_history/reactors/ebr\\_ii.html](http://www.anlw.anl.gov/anlw_history/reactors/ebr_ii.html)

It successfully passed a series of safety tests including those involving loss of coolant flow. Even with the normal shutdown systems disabled, the reactor safely stopped operating without reaching excessive temperatures.

The 4S vessel is expected to be installed up to 100 feet below grade. With the nature of the vessel's walls, placing it in a concrete structure at this depth will help reduce safety issues.

### 2.3.3 Security

## **Pre-Publication Draft – Subject to Change**

Since questions of security are foremost in our minds, the NRC-required risk assessment will consider this in depth. Installing the vessel deep underground with a large, heavy, reinforced concrete cap adds to the secure nature of the 4S installation. The core is designed so that the material is below the proliferation treaty limits. If it were to fall into the wrong hands, it cannot be easily converted or enriched to weapons-grade fuel.

No heavy equipment in Galena is capable of lifting/removing the cap. The cap would need to be broken and removed in pieces. Due to Galena's isolation, no group of insurgents could accomplish this without detection long before they could breach the vessel. Even if they did, the material in a core of this design would not be easily extracted.

In its economic analysis based on the current practices at large nuclear power plants in suburban areas of the lower 48 states and Japan, Toshiba conservatively estimated a security guard force of 34 would be required. Because of the design, isolation, and inaccessibility of the vessel or cooling loops, it is suggested that this level of surveillance may not be required. A detailed risk assessment will determine what level is needed. With remote monitoring from the City/State law enforcement offices, only one guard may be necessary on-site at all times. This would significantly reduce the manpower requirements and effect the economic assessment. Thus, in the economic section, we used four guards as a minimum and 34 guards as the upper level for security staffing.

## **2.4 Other Power and Heat Generation Modules**

In addition to those technological options for electricity generation discussed above, others can be used and are briefly described below. It was determined that these options would not contribute a significant enough amount of affordable energy to the utility for the utility to justify a major investment in them. However, Galena may want to consider implementing these technologies on a pilot scale within the next 10 years. If they might be proven feasible or reduced in price in the future, these technologies can be added to the utility as modules. Included are in-river turbines, solar, biomass, fuel cells, and coal bed methane. Therefore, these options are briefly discussed below – further details for some are provided in the Appendices.

### **2.4.1 Hydro In-river Turbines**

Galena is on the north bank of the Yukon River, one of the largest in the country. A tremendous amount of water passes the site each day – winter and summer - and it seems to be a logical place to install in-river turbines for electric power generation. However, compared to the load requirements of the City, this may not be a valid conclusion. From the discussion presented in Appendix 1, a variety of turbines are being developed, but none has been proven in arctic environments. The one apparently best suited to the Galena site is under development by UEK Corporation. It is proposed to be installed in rivers, anchored to the bottom, and operated year-around – even under ice. A project to demonstrate it at the village of Eagle on the upper Yukon River has been approved but is awaiting U.S. DOE funding. This turbine design has dual 3-meter diameter blades. To estimate the power output of such a unit at Galena, a look at the power density is in order.

## Pre-Publication Draft – Subject to Change

The power density in a flowing fluid is

$$P_{\max} = 0.5\rho V^3$$

For water flowing at  $V = 2$  m/sec (characteristic of the Yukon at Galena) and density  $\rho = 1000$  kg/m<sup>3</sup>, this corresponds to 4 kW/m<sup>3</sup>. For reasons related to mass conservation and efficiency, one may only be able to capture 40% of this or less with a conventional turbine. For a water turbine with two 3-meter turbines or area of 14.1 m<sup>2</sup>, this results in power generation of 22.5 kW – much less than that required by the City's load. Ten units would have to be installed to make even a marginal contribution and the cost may be too great for the benefit. UEK estimates \$1,000/kW capacity for a 10-MW plant yet to be built.

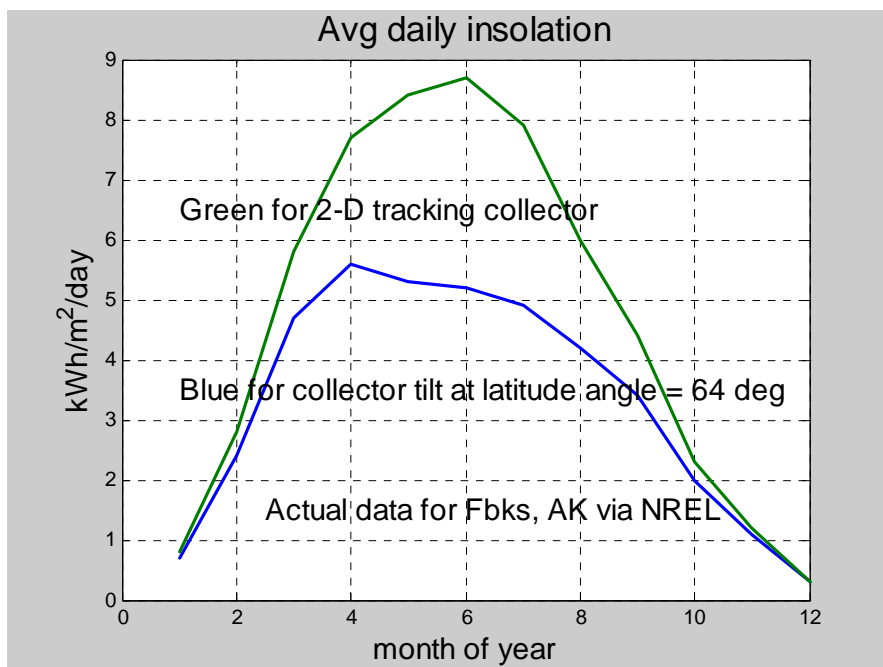
(<http://www.delawareonline.com/newsjournal/local/2003/09/06tidalpowerplant.html>)

On the other hand, an operational 300 kW tidal turbine in Norway costs \$23,000/kW capacity. (<http://www.eere.energy.gov/RE/ocean.html>)

### 2.4.2 Solar

Much of interior Alaska has a good solar resource for as much as eight months of the year. The National Renewable Energy Lab [NREL, 2004] has 30-year solar insolation data for hundreds of U.S. locations. Although there is no data for Galena, the plot shown in **Figure 2.8** below for Fairbanks probably provides a fair representation. Note, the data shows a substantial resource, even in the springtime, when both heat and electrical demands are high.

A downside to using solar energy is the intermittent nature of the resource. Hence, as with any intermittent resource, storage can be a key issue.





## Pre-Publication Draft – Subject to Change

**Figure 2.8.** Solar insolation data for Fairbanks, Alaska

### **2.4.2.1 Solar-electric**

Photovoltaic devices convert sunlight directly to electricity at efficiencies as high as 25%, although 10% is typical. Applications include residential both on and off grid, commercial buildings, remote systems for telecommunication, cathodic protection, pumping and irrigation, and land-based navigation aids. With output power densities around 125 W/m<sup>2</sup>, a 1-square-meter panel may produce a kW-hr each 8-hour day. Brown (1999) estimated electric power can be produced for \$0.20/kW-hr. Obvious shortcomings in northern Alaskan applications are associated with the lack of solar input during the winter when the demand for electrical power is the greatest. But the solar resource is still significant for two-thirds of the year in much of the state.

According to a study done in Arizona (McChesney, 2003), the average installed system costs in Arizona varied from ~ \$6/peak watt for grid-tied facilities to over \$20/peak W (or \$20,000/kWp) for off grid systems. The latter would include battery storage. Installation of a 100 kW module in a Galena setting could cost \$2M.

### **2.4.2.2 Solar Thermal**

Solar thermal technologies use the heat in sunlight to produce hot water, heat for buildings, or electric power. Solar thermal applications range from simple residential hot water systems to multimegawatt electricity generating stations. In Galena, discussions with the City Manager determined that this technology would more appropriately be installed by individual home or business owners. Its impact on the utility was determined to be limited. A more detailed discussion is presented in Appendix 2 and at the following web sites.

<http://solstice.crest.org/renewables/re-kiosk/solar/solar-thermal/index.shtml>

<http://www.eren.doe.gov/erec/factsheets/solrwafr.pdf>

<http://www.thermomax.com/>

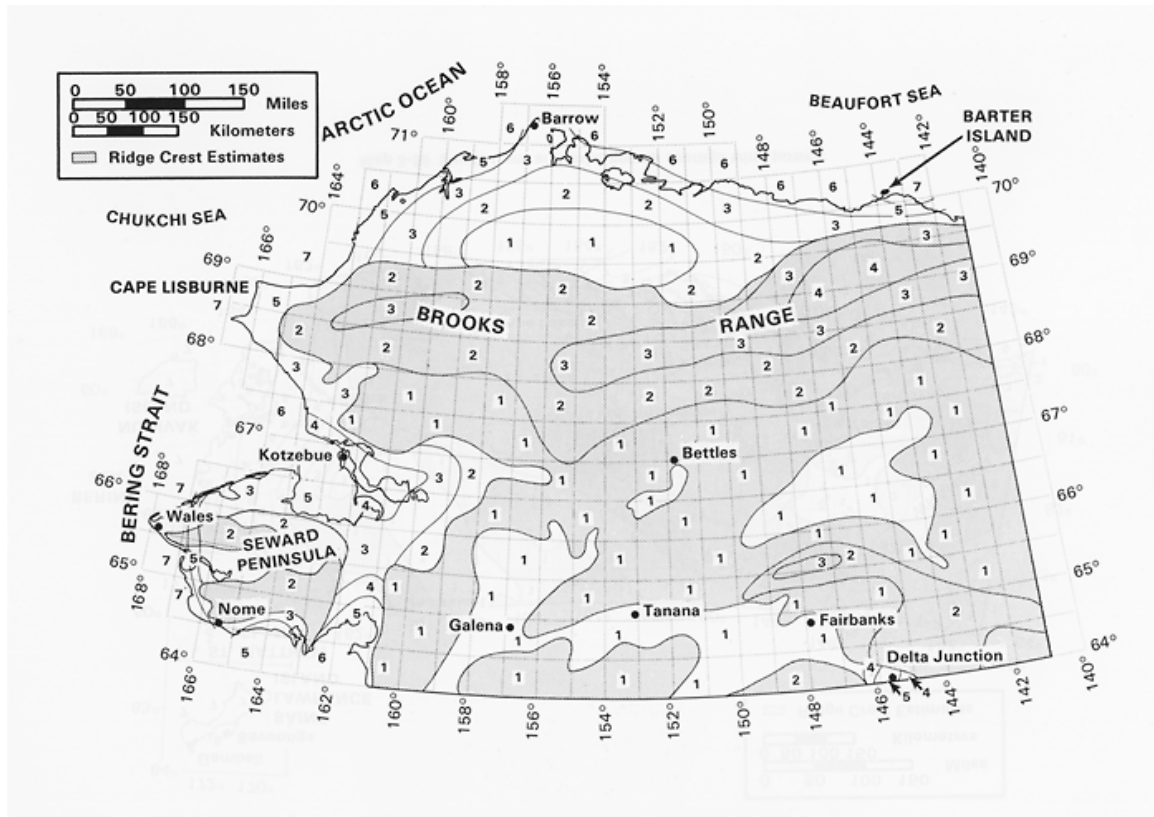
### **2.4.3 Biomass**

Biomass can be wood from trees as well as plant residue, animal waste, and the paper portion of municipal solid waste (MSW). The dispersed nature of this resource makes the energy and time involved in harvesting an important issue. With a typical MSW generation of 4 lb/capita/day and an energy content of about 4 K Btu/lb, such wastes from a village of 700 people may have a heating value of 11 M Btu/day. If this could be converted to electricity with 20% efficiency, the power output may be about 34 kW – too small for a stand-alone unit. However, MSW could be burned in the AFBC of the coal power plant.

### **2.4.4 Wind**

## Pre-Publication Draft – Subject to Change

Wind generation is making in-roads into electricity production worldwide. However, at best wind turbines make up to 15 to 20% of the utility load. They are being employed successfully in Alaska in Kotzebue, Wales, and St. Paul. To be effective, a certain level of sustained wind resource is necessary. **Figure 2.9.** shows the wind regimes in Alaska. Average wind speed must be greater than about 16 miles/hr on average for wind generation to be effective (Class 5, 6, or 7). Galena is in a Wind Class 1 region with average speed much too low to be feasible. Therefore, wind generation was not assessed in detail for this investigation.



<http://rredc.nrel.gov>

**Figure 2.9.** Alaska, North, Wind Map. Map of wind regimes in northern Alaska. More information can be obtained on the web at [www.bergey.com/Maps/Wind\\_classes.htm](http://www.bergey.com/Maps/Wind_classes.htm). Maps courtesy of U.S. DOE and NREL.

### 2.4.5 Fuel Cells

In fuel cells, hydrogen and oxygen are combined to produce water and release energy in the form of electricity. This reaction occurs in a thin layer on the surface of a membrane in the presence of a catalyst. Fuel cells convert the chemical energy of reactants (a fuel and an oxidant) into low voltage D.C. electricity via electrochemical reactions while generating almost no pollutants. Unlike conventional batteries, the fuel cell does not consume materials that are an integral part of its structure but rather acts as a converter. It will continue to operate as long as fuel and oxidant are supplied and reaction products are removed. Fuel cells require a minimum of maintenance, because

## Pre-Publication Draft – Subject to Change

they have very few moving parts. The most mature technology is the phosphoric acid fuel cell (PAFC), which utilizes hydrogen for the fuel and produces water. This product is valuable, especially in Alaskan villages in the winter, where potable water can cost over 10 cents/gallon. Since the water is produced at temperatures approaching 200°F, it can be used for space heating. Current capital costs for a 200-kW device are around \$4500/kW, with efficiency for electrical production around 40%. A 1-MW PAFC plant consisting of 5-200 kW cells was installed at an Anchorage, Alaska airport post office complex. The project lasted for 5½ years and at the end, the cells were degraded to the point they needed to be replaced.

Other types of cells being actively developed include direct methanol (DMFC), molten carbonate (MCFC), and solid oxide (SOFC). The DMFC has the advantage of being fueled with a liquid fuel (methanol) which is more readily obtained than hydrogen. A disadvantage is crossover of some methanol from the anode to cathode side. The latter two offer the potential for internal reforming of conventional liquid and gaseous fossil fuel into hydrogen. Their higher operating temperatures also are more compatible with cogeneration. Disadvantages include the need for more expensive materials at these higher temperatures.

Since most fuel cell stacks under active development today require hydrogen as the fuel, reformers at the front end to convert fossil fuels to hydrogen are being developed. So far, cleaner fuels such as natural gas and methanol are easier candidates than "dirtier" fuels such as diesel and gasoline. Sulfur and CO in small concentrations can poison catalysts used in the stack membranes. It must be noted that when fossil fuels are used to produce hydrogen, CO<sub>2</sub> is released.

A second strategy is to use excess electrical generation capacity to generate hydrogen from water (electrolysis) and store the hydrogen for later use. This excess electrical power could come either from a renewable source, such as wind generation, or from excess capacity of existing diesel electric generators, using fuel cells in a load-leveling application.

The proton exchange membrane (PEM) fuel cell operates at around 60°C and has solid polymer membranes sandwiched between carbon cathodes and anodes. With a little less than one volt per cell, it takes about 18 cells in series to generate 12 volts. (Johnson et al., 2000). Multinational corporations such as Daimler Chrysler are spending billions of dollars developing this technology for transportation applications. Several corporations are also interested in this technology for stationary power.

Currently, this promising technology is not commercially available and thus was not considered for Galena deployment.

### 2.5.6 Coal Bed Methane

Gas has been produced commercially from coal beds in the lower 48 states. Development of resources in other parts of Alaska is in the preliminary stage. Insufficient information is available about how to develop CBM in arctic conditions to consider it for Galena. If considered for development, extensive work to delineate local reserves is required before development could occur.

### **3. ENERGY CONSERVATION**

Important technologies and techniques, that impact the amount of electricity required of the utility, are available for energy conservation but implementation of them is end-user driven and best conducted by the users. Therefore, a discussion of conservation is included here for reference.

Energy conservation refers to a variety of strategies employed to reduce the demand for energy. This can include adding extra insulation on building exteriors, setting building thermostats closer to ambient temperatures, or carpooling. Conservation is different from increasing energy efficiency, which refers to increasing the useful output for a given energy input. This could involve replacing incandescent light bulbs with compact fluorescent ones, driving more fuel-efficient motor vehicles, and purchasing more efficient appliances. All of these practices are end-user initiatives. Even though end-use conservation is not the primary utility activity, utilities may help educate and encourage consumers. Utilities throughout the United States are engaged in energy conservation programs. For example, GVEA's Energy Conservation Program is outlined in Section 7.1 of the Administrative Manual. Some highlights of this program include

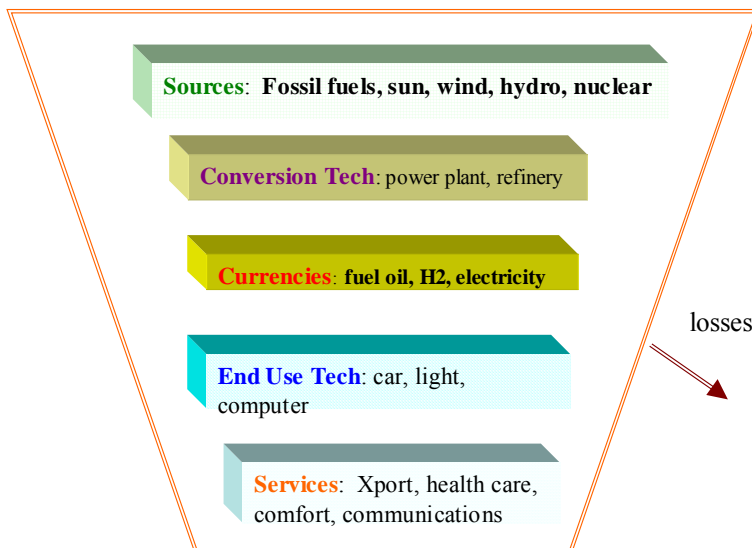
- (a) developing and maintaining an effective load-management program,
- (b) providing conservation information to the membership,
- (c) monitoring energy use in all aspects of operations including facility operation, facility construction, and use of vehicles, and
- (d) maintaining an active employee training program.

A detailed discussion of the options and benefits of conservation is given in the Appendix B.

### **4. USES OF EXTRA POWER**

One unifying way to picture the flow of energy is by considering the below energy trapezoid as presented by Scott (2002) and others in **Figure 4.1**.

This study is focused on the top three items, sources and technologies and their ability to supply heat and electricity or other energy forms. The energy currencies of today are fossil fuels and electricity, but many believe hydrogen may be an important fuel in the future. What we want to provide are end services with several listed in the bottom part of the energy trapezoid.



*Adapted from Scott(2001)*

**Figure 4.1. Energy Trapezoid**

Some of the power plant enhancements being considered may provide electric power and heat at rates in excess of today's loads. Hence, one needs to consider growth in these loads such as that associated with population increases, new commercial enterprises, development of a regional grid, or tourism. In the future, if hydrogen becomes a vibrant energy currency, Galena could serve as a production center through water electrolysis powered by a coal or nuclear-fueled central power plant.

### **4.1 District Heating – Sales to Air Station**

District heating currently serves the needs of the school, town offices, swimming pool, fire hall, and the power and water plants. Currently, the air station area gets space heat via oil-fired boilers that consume around 471,000 gals/yr of diesel fuel. This heat is delivered to individual buildings by utilidor. Part or all of this fuel could be displaced by district heating. If the power plant [nuclear, coal, or diesel] supplying this co-generated heat were located, say, 2 miles from the thermal load, a substantial capital expense would be required to construct the heat transmission line (\$200/ft). But, the losses in a well-insulated line would be substantially less than the heat delivered.

### **4.2 Residential Electric Heating**

If electric rates to the homeowner can be sufficiently reduced, there is a strong possibility that many of the approximately 220 residences (and commercial/office buildings) would convert to electric baseboard heat as their primary method of heating. There are several reasons this may be attractive. If the cost is lower than the use of fuel oil, economics becomes a strong driver. Additionally, a clean heating source reduces contaminants in the air of the building thereby increasing the indoor air quality. Indoor air pollution is of particular concern during the long winter months when most people stay indoors much of the time. Convenience is also a strong incentive. Baseboard heat is even and automatic, reducing the need to bring fuel inside (as wood-fired stoves require) or fill/haul fuel tanks.

If it is assumed the 220 residences were converted to electric baseboard heat, the following summarizes the costs and requirements. Each home requires about 15 kW of heating capacity (50,000 Btu). Baseboard heaters cost \$50/kW and about \$25/kW for shipping and installation. Thus, each home would require an investment of \$1,125 to install the heating systems. Each home may also require up to \$1,000 investment to upgrade the service and wiring to handle the increase in load. This investment might be financed through the utility as an incentive for residents to convert. For this reason, the overall costs are included as part of the capital cost in assessing the economics of the 4S nuclear system. An estimated \$250,000 would be required to

## Pre-Publication Draft – Subject to Change

upgrade the utility distribution system and purchase a replacement transformer. The following calculation yields \$717,500 as the total cost for conversion.

$$\frac{15 \text{ kW}}{\text{residence}} \times \frac{\$75}{1 \text{ kW}} = \frac{\$1125}{\text{residence}} \times 220 \text{ residences} = \$247,500$$
$$\$247,500 + \frac{\$1000}{\text{electric service upgrade}} \times 220 \text{ residences} = \$467,500$$
$$\$467,500 + \frac{\$250,000}{\text{distribution transformer \& feeders}} = \$717,500$$

Note that this cost estimate does not include the cost of electricity and is independent of the source. Supplying power for electric baseboard heaters from existing DEGs would result in operating costs much greater than for current forms of heating (oil furnaces and wood stoves). This option is discussed in more detail in the economics section.

### 4.3 Hydrogen Production

Many are projecting that hydrogen will be the fuel of the future. While there are some good reasons for this, significant issues that must be addressed. Hydrogen is the lightest element and thus has a very low density. It easily diffuses through many materials including some metals. One gallon of liquefied hydrogen weighs just 0.58 lbs (gasoline weighs over 6 lb/gal). It has a high energy content, but its low density means it has a low energy density (Btu/unit volume). Liquid hydrogen's energy density is about 22% of that for #2 diesel fuel. Thus, storage and containment are significant issues relative to hydrocarbon fuels.

Hydrogen is not a primary fuel as are conventional fuels such as natural gas, coal, and petroleum, but rather it is an energy carrier. Hydrogen does not occur in a free state in nature (because of its reactivity with oxygen to form water). Thus, hydrogen used as a transportation fuel must be made employing significant amounts of primary energy. Most hydrogen used is currently made from reforming of natural gas. It can be made by electrolysis of water – requiring large amounts of electricity. However it is made, more energy is used in its production than it contains. If produced from electricity from a 40% efficient coal-fired power plant, with a 75% efficient electrolyzer, the energy content of the hydrogen product would contain at most 30% of the energy of the coal used to produce it. Hydrogen is attractive as an alternative for transportation fuel because it burns very cleanly and has no by-products except water and perhaps some traces of nitrogen oxides. It produces no carbon dioxide. There is currently very little infrastructure for the production, storage, and distribution of hydrogen on a large scale anywhere in the world.

In Galena's setting, hydrogen would most efficiently be used locally in the community, because storage tanks are expensive. If it had to be shipped outside the City, tank storage would be required to store the production during the winter (about seven months) when the barges cannot use the river, adding significant capital cost. Shipping of the product might be envisioned using semi trailer mounted tanks that could be barged to Nenana and pulled to Fairbanks or Anchorage for sale to the military, railroad, or other users. Shipping in this manner would add more than \$0.90/gal to the

## Pre-Publication Draft – Subject to Change

cost, making it prohibitively expensive.<sup>4</sup> Therefore, it was concluded that any hydrogen enterprise should be sized to be used entirely in Galena.

For purposes of this study, it was assumed the venture would be a private enterprise and the economics were calculated as such. A modular plant was conceptualized and after several iterations, a plant based on the concept outlined by Air Products was used as a basis. It would use 1 MW as the input to the electrolyzer with a total power requirement of 1.5 MW. The output could be as large as 404,000 gallons per year of liquid hydrogen, matching well with the projected local demand. No provision was made to collect or market the coproduced oxygen. The economics were run assuming that the Air Station equipment was converted from diesel (50,000 gal/yr) and the school district buses and city vehicles were converted from gasoline (25,000 and 15,000 gal/yr, respectively).

**Table 4.1.** Equivalent liquid hydrogen needed to displace local petroleum based fuels

	Current Fuel Use	Equivalent Liq. Hydrogen
Air Station Vehicles	50,000 gal/yr diesel	229,000 gal/yr
School buses	25,000 gal/yr gasoline	94,000 gal/yr
City Vehicles	15,000 gal/yr gasoline	<u>56,000 gal/yr</u>
	TOTAL	379,000 gal/yr

Therefore, the local market could use about 94% of the production capacity.

**Table 4.2.** Results of hydrogen economic analysis

Capital	Power Cost	Production Cost	Target Price
\$6.2 million	-0-	\$46/M Btu	\$15-30/M Btu Diesel equivalent
-0-	\$0.015/kWh	\$17/M Btu	

Based on these assumptions, on a Btu comparative basis, hydrogen cannot compete with diesel and gasoline. However, if as a demonstration the capital equipment could be procured via a grant, with a low electrical power cost, the fuel can be produced at a rate comparable to diesel. Details are presented in the Economics Section.

Excess electricity could also be used to produce hydrogen via electrolysis of water. With a 70% efficient electrolyzer, each MW of electric power could produce hydrogen at an energy flux rate of 700 kW. An energy content of 141.8 MJ/kg = 39.4 kWh/kg results in an H<sub>2</sub> production rate of 17.8 kg/hr. Under 1 atmosphere pressure and 0°C, 2 kg of H<sub>2</sub> occupies 22.4 m<sup>3</sup>. If pressurized to 300 atmospheres [about 4500 psi], one day's production of H<sub>2</sub> would occupy about 16 m<sup>3</sup>. If stored for periods of weeks, the storage costs [amortization of the capital costs of the container] become significant. The

<sup>4</sup> based upon barge shipping rate quotes, Inland Barge Service, Nenana, Alaska, May 2004

## Pre-Publication Draft – Subject to Change

energy required for compression is a few percent of the energy contained in the hydrogen.

### 4.4 Transmission to Other villages

A regional grid could link five neighboring communities with transmission lines supplied by a central power plant in Galena. These five communities have a combined generation capacity of about 3 MW with the farthest (Kaltag) being 83 river miles away.

**Table 4.3.** Cost of installing a transmission line to serve near-by villages

Village/ Population	Distance			Cost (\$million)		Total for Segment
	From Galena	From Previous Village	Portion Along Roads	Road Portion @\$80K/mi	Overland Portion @\$200K/mi	
<b>Down Stream</b>						
Koyukuk/ 169	32**	32	5	0.4	5.4	5.8
Nulato/ 336	50**	18	4	0.32	2.8	3.1
Kaltag/ 230	83**	33	5	0.4	5.6	6
			<b>TOTAL</b>	1.1	13.8	14.8
<b>Up Stream</b>						
Ruby/ 169	42*		9	0.72	6.6	7.3
			<b>TOTAL</b>	1.8	20.4	22.2

\* Used a direct route on north shore of Yukon River

\*\* Used abandoned telegraph right-of-way to estimate

From Galena, Ruby is the closest village upstream on the Yukon. It is roughly 52 river miles away. If a transmission line was run along the north shore of the river cutting across some of the oxbows, the distance is estimated to be about 42 miles. Going downstream, a line could be run to pick up Koyukok (32 miles), Nulato (an additional 18 miles), and Kaltag (an additional 33 miles). **Table 4.3.** summarizes the cost for the lines. That portion of each leg, which can be constructed along a road is estimated to cost \$80,000/mile and overland the cost is \$200,000/mile, based on Galena and AVEC experience. Using these assumptions, a transmission line from Galena downstream to Koyukok, Nulato, and Kaltag covers about 85 miles along the river and would cost an estimated \$15 million. A line upstream to Ruby (population 169, generation capacity of 0.6 MW) would cost about \$7.3 million. Thus, for a total of about \$22.2 million, about 800 people with a load of 1.8 MW could be served. Details of the economic assessment of the Transmission Options are presented in the Economics Section.

### 4.4 Greenhouses and Aquaculture

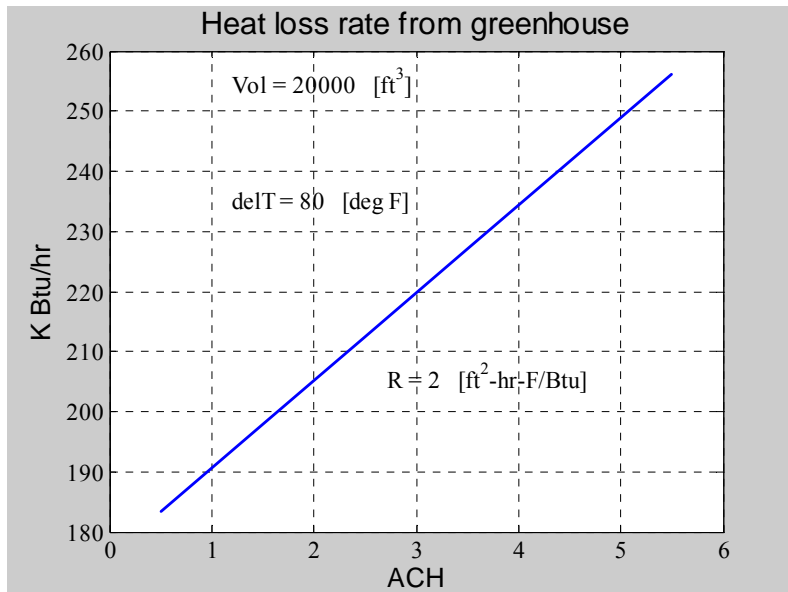


## Pre-Publication Draft – Subject to Change

With the copious amounts of low-grade heat produced in conjunction with power production, several opportunities for commercial enterprises exist, such as raising produce in greenhouses and fish farming. These ventures could supply Galena and surrounding villages with fresh and relatively low-cost produce. Fish raised in tanks could provide for local consumption or be marketed as fresh, frozen, and processed products. Besides providing fresh produce, new businesses such as this would provide employment opportunities.

### 4.4.1 Greenhouses

Galena has plenty of sunlight in the springtime and could readily grow various crops such as tomatoes, potatoes, squash, cabbage, carrots, etc. if the proper environment could be maintained. This includes the right temperature and an adequate supply of clean air. To illustrate, suppose one needed to keep a 100 x 20 x 10 ft greenhouse 80°F above ambient in which the shell had an R value of 2 ft<sup>2</sup> hr ° F/Btu, representing a day in March. **Figure 4.1** below illustrates how much heat would need to be supplied as a function of air changes per hour assuming a 50% efficient heat recovery ventilation system. This heat rate represents a small fraction of the rejected heat from a multimewatt power plant.



**Figure 4.2.** Heat load for a greenhouse

### 4.4.2 Aquaculture

Raising fish in tanks (farming) is often controversial, because of the concern of farmed fish escaping into local streams. However, if allowed and permitted by state and local processes, it is another avenue open for local entrepreneurs to use the heat produced by power plants of various types. Fish could be used locally or processed into frozen or value-added products for sale outside.

An example is trout production. Requirements include;

## Pre-Publication Draft – Subject to Change

- Water temperatures of 8°C to 18°C are recommended
- Dissolved oxygen in excess of 5 mg/L
- 10-20 kg fish/cubic meter (22-44 lbs/264 gallons)
- Flow rates of recharge water = 510 L of water/sec/ton of fish (153 gallon/sec/ton)

Other species have less stringent water requirements. An economic comparison and assessment for various species would have to be conducted as part of the business planning process. (Gooley, 1997)

## 5. ENVIRONMENTAL ISSUES AND PERMITTING

### 5.1 Primary Environmental and Permitting Issues

All major aspects of power generation and distribution will carry with them some adverse environmental effects. There will be effects relating to the construction and operation of power plants, regardless of the means by which the power is generated. There will also be potential environmental effects from operating each type of power plant. Transportation of fuels and/or power plant components will also involve environmental impacts, especially if new power lines and/or roads are necessary. Each of the three primary energy options addressed in this report (diesel, coal, and nuclear) will also result in the emission of water and air pollutants and the generation of wastes of various types. In the case of coal, disturbance from mining must also be considered. Each of these potential threats to the environment are regulated by one or more agencies of the state or federal government.

The purpose of this portion of the Galena Energy Assessment is to (1) briefly summarize the key environmental issues associated with the primary energy options; (2) provide a short summary of the state and federal regulations that address these environmental issues; and (3) rank the primary energy options in terms of the effort and costs that will be associated with the various options. This section is *not* intended to provide a comprehensive assessment of environmental issues and permitting for energy development but is intended to provide a high-level summary of the key environmental issues relating to the potential diesel, coal, or nuclear power generation at Galena. Such a comprehensive assessment will be part of the overall permitting process, regardless of which option (or options) the City of Galena selects to pursue.

For the sake of convenience, environmental impacts associated with energy production and delivery can be placed into four general categories:

- (1) significant **disturbances** of land and surface water, and groundwater;
- (2) emission of **air pollutants**;
- (3) emission of **water pollutants**; and
- (4) management of various types of regulated **wastes**.

## Pre-Publication Draft – Subject to Change

### 5.1.1 Disturbance

These issues are covered by a wide variety of permitting and licensing requirements from an equally wide variety of state and federal agencies. A partial list of issues and the agencies responsible for regulating those issues is provided in **Table 5.1**.

Permit requirement	Primary regulatory agency
NEPA Environmental Impact Statement	U.S. Environmental Protection Agency
Storm water Discharge Permit	U.S. Environmental Protection Agency
Threatened and Endangered Species and Critical Habitat Assessments	Alaska Department of Fish and Game
Wetlands Assessment	U.S. Army Corps of Engineers
Building Permits	Alaska Department of Public Safety
Wastewater and sewage permits	Alaska Department of Environmental Conservation

### 5.1.2 Air Pollution

Control of air emissions in the United States is regulated under the Clean Air Act as amended in 1990. At the national level, new air pollution point sources are regulated by the U.S. Environmental Protection Agency (EPA). However, as with most environmental regulations at the national level, the Clean Air Act provides states with the option to take over regulatory authority for air pollution sources within their boundaries. In Alaska, the Department of Environmental Conservation – Division of Air Quality is the primary regulatory agency with respect to air emissions. The State of Alaska therefore maintains primacy over air quality issues in the state through Title 44, Chapter 46, and Title 46, Chapter 3 and Chapter 14.

### 5.1.3 Water Pollution

Control of water pollution in the United States is also maintained by the EPA under authority of the Clean Water Act. In contrast to the situation with air emissions, however, the State of Alaska has not opted to take over regulatory authority from EPA. For this reason, any water pollution permitting must be through the EPA rather than through a state agency. Much of the general information on water pollution issues is taken directly from the EPA internet web sites.

<http://cfpub2.epa.gov/npdes/regs.cfm?program>

Although there are differences in water permitting needs for the three primary energy options discussed in this report, the primary permitting issue for each will be storm water permitting under the National Pollutant Discharge Elimination System

## **Pre-Publication Draft – Subject to Change**

(NPDES). Administered by the EPA, the NPDES regulates point sources that discharge pollutants into waters of the United States. An NPDES permit is required for any construction activity that disturbs one acre or more of land, including construction of the power plant, roads, power lines, tank farms, mines, ore processing facilities, etc. On March 10, 2003, new regulations came into effect that extended coverage to construction sites that disturb one to five acres in size, including smaller sites that are part of a larger common plan of development or sale. Sites disturbing five acres or more were regulated previously.

Where the EPA is the permitting authority, the Construction General Permit (CGP) outlines a set of provisions construction operators must follow to comply with the requirements of the NPDES storm water regulations. The CGP covers any site one acre and above, including smaller sites that are part of a larger common plan of development or sale, and replaces and updates previous EPA permits. To be eligible for coverage under the Construction General Permit (CGP), you must assess the potential effects of storm water discharges and storm water discharge related activities on federally listed endangered and threatened species and any designated **critical habitat** that exists **on or near** the site. In making this determination, one will need to consider areas beyond the immediate footprint of the construction activity and beyond the property line, including those that could be affected directly or indirectly by storm water discharges.

### **5.1.4 Waste Management**

Each of the three primary energy options will generate waste of various types. In Alaska, solid wastes (nonhazardous) are regulated by the Alaska Department of Environmental Conservation. Solid wastes will be a substantial issue with the coal option because coal mine overburden is classified as a solid waste. Each option will also generate some volume of wastes classified as hazardous. The primary authority for regulating hazardous wastes is the Resource Conservation and Recovery Act (RCRA), administered by the EPA. Regulatory authority for hazardous wastes in Alaska, however, is shared between EPA and the Alaska Department of Environmental Conservation.

Radioactive waste is unique in that it is regulated by the U.S. Nuclear Regulatory Commission (through a memorandum of understanding with the EPA) under authority of the Atomic Energy Act.

## **5.2 Enhanced Diesel**

### **5.2.1 Background and Assumptions**

It is assumed that a new diesel plant and related infrastructure will be located near the existing power plant, reducing the need for the construction of additional roads, power lines, and tank farms, thereby simplifying the environmental permitting process. It is also assumed that fuel will be transported to Galena in the same manner as at present, primarily by barge during the summer shipping season on the Yukon River. Although the permitting process for this option is probably the least restrictive, numerous permits will have to be obtained for the diesel option to be implemented.

#### **5.2.1.1 Disturbance.**

## **Pre-Publication Draft – Subject to Change**

In comparison to the coal and nuclear power plant options, and based on the assumptions listed above, construction and operation of an enhanced diesel power plant will likely result in less disturbance of land and waters than the other primary options. However, a number of state and federal permits could be required, especially if additional roads and/or power lines are necessary.

### ***5.2.1.2 Air Pollution.***

The Alaska DEC Division of Air Quality has a general air quality operating permit for diesel electric generating facilities. This permit can be accessed through the DEC website (<http://www.state.ak.us/dec/air/ap/docs/gp1.pdf>). The general permit covers emissions of primary pollutants such as oxides of nitrogen and sulfur, respirable particulates (PM-10), volatile organic compounds, and carbon monoxide, all of which may be released from the power plant stack. There are also provisions for visible emissions (smoke) from the power plant, and for emissions from stored fuel.

### ***5.2.1.3 Water Pollution.***

A storm water permit through the EPA NPDES program will be required for any construction activity, including the new power plant, tank farm, roads, or power lines. Requirements for spill prevention and response may also be imposed.

## **5.3 Coal**

### **5.3.1 Background and Assumptions**

For coal to be a viable option as an energy source for the City of Galena, it has been assumed that a surface coal mine would be developed above old Loudon, and a coal-fired steam plant would then be built in or very near the City. All aspects of coal production and use must therefore be considered – from permitting the mine itself to the disposal of wastes generated by the power plant. All of the infrastructure required to extract the coal, transport the coal, and produce the power must therefore be considered. It is also assumed that coal generated would be used locally and not be shipped to market elsewhere.

Power generation using locally derived coal can be viewed as a five-step process: (1) mining; (2) preparation (primarily crushing); (3) transport; (4) power generation; and (5) waste management. Each of these basic steps in coal power generation has inherent environmental issues associated with it, and each is regulated by one or more state or federal agencies.

#### ***5.3.1.1 Coal Mining.***

Much of the information in this section on coal mining environmental issues and permitting is taken directly from internet web sites of the Alaska Department of Natural Resources (DNR). Background information on Alaska's Coal Regulatory Program is taken largely (and often directly) from an Alaska Division of Mining, Land, and Water web site (<http://www.dnr.state.ak.us/mlw/mining/coal>). Permitting requirements for

## Pre-Publication Draft – Subject to Change

surface coal mining are provided on a related DNR web site (<http://www.dnr.state.ak.us/mlw/mining/coal/coalreg.pdf>).

Although coal mines have operated in Alaska since 1855, only two mines are currently operating in Alaska: the Gold Run Pass Mine and the Poker Flats Mine. Both mines are owned and operated by Usibelli Coal Mine, Inc., and both are located within six miles of each other east of Healy. Usibelli has been mining coal in the Healy area since 1948. Production therefore began before the current federal and state regulatory programs were put into effect, so not all of the standards that would be applied to a new mine are actually in effect at the two Usibelli mines. Also, coal mining is regulated in a manner that is entirely different from that of other types of mines. Points of comparison for environmental compliance for any new mine near Galena or elsewhere in Alaska are therefore generally lacking.

At the federal level, coal mining is regulated primarily by the Surface Mining Control and Reclamation Act (SMCRA) of 1977. This Act substantially increased the environmental oversight applied to coal mining nationwide. As with many federal environmental regulations, SMCRA also provided individual states with the opportunity to assume primacy over the federal program by developing a state regulatory program for coal in a manner which complies with federal SMCRA standards. Alaska opted to develop its own program consistent with SMCRA, enacting the Alaska Surface Coal Mining Control and Reclamation Act (ACMCRA) in 1983.

ACMCRA is administered by the Alaska Division of Mining, Land and Water Management (DMLW), a division of the Department of Natural Resources. The Act comprehensively regulates almost all aspects of coal mining activity from exploration through final reclamation. Some of the more important parts of the program include the following (<http://www.dnr.state.ak.us/mlw/mining/coal/>):

- Exploration permit: Permitting is required before any coal exploration activity occurs on any land ownership (federal, state, municipal, or private lands).
- Review Process: Any new mine proposal must undergo extensive review before any permit is approved. The review includes at least two separate public notice periods and is highly prescribed by regulation.
- Performance Standards: 65 separate performance standards are set for various coal mining activities, everything from the placement of signs to statistical requirements for measuring revegetation success.
- Inspection: DMLW personnel must inspect each operating coal mine an average of once each month.
- Penalties: Criminal and civil penalties are enforced for violations of ACMCRA.

### **5.3.1.2 Disturbance from Mining**

It is impossible to mine coal without disturbing large areas of the land surface. This is especially the case with surface mines, although land disturbance from subsurface, tunnel mines may also be substantial. Disturbance of the environment due to mining is generally covered by reclamation requirements, and one of the primary goals of ACMCRA (and SMCRA) is to ensure that reclamation is performed in an effective and timely manner. Toward that end, the State of Alaska's coal mining

## Pre-Publication Draft – Subject to Change

regulations contain a variety of reclamation requirements. To ensure that reclamation is accomplished adequately, the operator must submit a reclamation bond before mining begins. This bond must be sufficiently large to allow the state to reclaim the site if the operator fails to do so. The Usibelli Coal Mine, Inc. has pledged a collateral bond of approximately \$3 million for the reclamation at its two mines. Once the area is reclaimed, the state can incrementally release the bond. Alaska's coal program regulations require that final bond release not occur until at least 10 years after the mine site is graded and initial vegetation established. The 10-year period is intended to provide time to determine whether revegetation is successful. The Usibelli Coal Mine, Inc., has a full-time reclamation engineer on staff, as well as seasonal reclamation work crews. Each year, the company seeds and fertilizes land being reclaimed. In 1997, they planted several thousand birch, willow, alder, and spruce seedlings on the two mines. Reclamation requirements may be found on the Alaska DNR internet web site (<http://www.dnr.state.ak.us/mlw/mining/coal/coalreg.pdf>).

DMLW recently approved a new mine permit for the Two Bull Ridge Mine. Some of the important reclamation provisions of the permit were the following:

- **Topsoil:** An extensive pre-mining soil inventory was conducted, and all soils removed were required to be saved except those that are unsuitable for reclamation use and those on steep slopes. All of these salvaged soils will ultimately be placed back onto reclaimed areas. As the active mining area moves through the 832-acre area of the mine, grading will be completed and topsoil will be replaced within approximately 800 feet of the actively mined area.
- **Post-Mining Land Use:** The mining area will ultimately be reclaimed for wildlife habitat, which was the predominant pre-mining land use.
- **Revegetation:** Usibelli's Revegetation Plan has two parts. First, the area will be seeded with native grasses to quickly establish a ground cover that will control erosion. Second, although they expect natural regeneration to provide the larger woody plants, this natural regeneration process will be accelerated by planting 100 plants per acre using naturally occurring woody plants such as willow, alder, or spruce.

### ***5.3.1.3 Air Pollution for Coal Mining***

For coal mining, the primary air pollution issues include the generation of fugitive dust and the potential release of methane. These emissions will be controlled under a permit by the Alaska Division of Air Quality.

### ***5.3.1.4 Water Pollution for Coal Mining***

Aside from standard storm water discharge issues, coal mining is a water pollution concern primarily because of acid mine drainage. Requirements of the EPA will restrict or eliminate the potential for acid mine drainage. The greatest water pollution regulatory burden for coal mining will be the NPDES permitting, which has been cited as "the greatest obstacle to timely development of mines in Alaska" (Report of the 2004 Alaska Minerals Commission).

## Pre-Publication Draft – Subject to Change

### 5.3.1.5 Waste Management for Coal Mining

A solid waste disposal permit will be required from the Alaska Department of Environmental Conservation. The most recent solid waste disposal permit approved in Alaska was a renewal of a solid waste disposal permit for the Usibelli mine. This permit (<http://info.dec.state.ak.us/decpermit/eh/sw/0031-ba002.pdf>) is for the continued operation of “an inert waste monofill for construction and demolition debris, shop wastes, and coal ash, located at the Usibelli Coal Mine “... in accordance with AS 46, 18 AAC 15, and 18 AAC 60.” The permit was issued in April 2000, and extends for a five-year period, after which it must be renewed again. The Usibelli permit allows for the disposal of these specific nonhazardous waste types “within the boundaries of the Poker Flats and Two Bull Ridge mining areas at Usibelli Coal Mine.”

### 5.3.2 Coal Preparation – Air Pollution

In April 2003, the Alaska Department of Environmental Conservation, under the authority of AS 46.14 and 18 AAC 50, issued Air Quality Operating Permit No. 317TVP01 to the Usibelli Coal Mine, Inc., for the operation of the Usibelli Coal Preparation Plant. This permit is in force until the expiration date of May 13, 2008. The Usibelli permit included provisions limiting emissions of regulated air contaminants including particulate matter (PM-10), Sulfur Oxides (SO<sub>x</sub>), Nitrogen Oxides (NO<sub>x</sub>), Carbon Monoxide, and Volatile Organic Compounds (VOCs), and requires the permittee to submit assessable emission estimates no later than March 31 of each year. The submittal is required to include all of the assumptions and calculations used to estimate the assessable emissions in sufficient detail so they can be verified. A list is provided below of sources at the Usibelli mine site that have specific permit stipulations for monitoring, record keeping, or reporting conditions. From **Table 5.2** (below) each source has stipulations associated in the permit. Many of these involve record keeping.

**Table 5.2** Usibelli Coal Preparation Plant Source Inventory



## Pre-Publication Draft – Subject to Change

ID	Source Name	Source Description	Rating/size	Install Date
1	CRU1-Primary Crusher	Stamler Feeder Breaker-12465	1,400 Tph	1986
2	CRU2-Secondary Crusher	McNally 34 x 38	1,000 Tph	1982
3	CRU3-Secondary Crusher	Gundlach	500 Tph	1997
4	SCR1 Screener	Rippleflow Screener	500 Tph	1997
5	SCR2 Screener	Rippleflow Screener	500 Tph	1997
6	TRA1	Transfer point #1	500 Tph	1997
7	TRA2	West Tipple Transfer	400 Tph	1997
8	FIN1	Fine coal Loadout	1,400 Tph	1982
9	DUM-1	Truck Dump	1,400 Tph	1990
10	TRN1	Train loadout	2,500 Tph	1992
11	TRK1	West Tipple Truck Loadout	200 Tph	1996
12	STK1	Coal Stockpile Loadout	20,000 tpy – loadout	1992
13	Boiler 1	Kewanee Coal fired	7.22 M Btu/hr	1982
14	Boiler 2	Ferrar & Trefts 578 Coal fired	7.69 M Btu/hr	1977
15	Boiler 3	Hastings 55A Diesel fuel	1.0 M Btu/hr	1996
16	Boiler 4	Kewanee 4430 Waste Oil	5.0 M Btu/hr	1996
17	Tank 1	Diesel Fuel	24,000 gal	1993
18	Tank 2	Diesel Fuel	24,000 gal	1993

### 5.3.3 Coal – Transportation

A new coal mine, even if “local,” will require that some new roads be built. For Galena, the type and distance of these roads will depend on a number of factors, including (1) how close the mine and coal processing facilities are located from the power plant; and (2) whether coal will be produced to be shipped for use elsewhere. Construction of new roads in Alaska require a number of permits, the most substantive of which are summarized below:

#### 5.3.3.1 Federal

**U.S. Army Corps of Engineers:** Disturbance of any lands containing wetlands requires a permit (or waiver) from the Army Corps of Engineers before any dredged or fill material is placed in wetlands. The Corps is responsible for determining whether an area is wetland for permit purposes and issues permits for dredging, filling, or placing structures in tidal waters, streams, lakes, and wetlands. For additional information, or for a wetlands determination, contact the U.S. Army Corps of Engineers, Regulatory Branch, PO Box 898, Anchorage, AK 99506-0898 (1-800-478-2712).

**U.S. Environmental Protection Agency:** As described in previous sections, the EPA manages NPDES storm water permits required for all construction projects that disturb over 5 acres of land. Contact information: U.S. Environmental Protection Agency, Region 10, Office of Water, 1200 Sixth Avenue, Seattle WA 98101 or

## Pre-Publication Draft – Subject to Change

1-800-424-4372 x6650. Permits available at <http://www.epa.gov.r10earth/stormwater.htm>

### **5.3.3.2 State of Alaska**

**Department of Fish and Game:** The Alaska Department of Fish and Game is responsible for issuing permits for any activities or projects which impact waters that support salmon and high value resident fish species as well as for activities within Critical Habitat Areas, State Game Refuges and State Game Sanctuaries. Contact the Alaska Department of Fish & Game, Habitat & Restoration Division, 333 Raspberry, Anchorage, AK 99518. (907) 267-2285.

**Department of Public Safety:** A State building permit is required for all commercial buildings for any location in the State. The State Fire Marshal issues permits after appropriate plans and specifications are submitted and approved. Information and application are available at: State Fire Marshal, 5700 East (907) 269-5604, Tudor Road, Anchorage, AK 99507

**Department of Environmental Conservation:** The Alaska Department of Environmental Conservation (ADEC) provides and enforces standards for water quality and waste disposal, as described in earlier sections. For information specific to domestic water wells and septic systems, contact the state or local ADEC office.

### **5.3.3.3 Local**

There may also be additional permits required relating to construction, zoning, easements, covenants, waste disposal, flood plain development, critical habitat, etc.

### **5.3.4 Coal Power Generation**

Construction of a coal-fired power plant in Galena will require a number of construction, air pollution, water pollution, and waste management permits. Air permits will deal with emissions for sulfur and nitrogen oxides, particulates, and carbon monoxide, and may also restrict visible emissions. For water, an NPDES permit will be required for the power plant, and thermal loading to waters may also be restricted. Waste management will include disposal of ash and other materials.

## **5.4 Toshiba 4S Nuclear Plant**

The U.S. Nuclear Regulatory Commission (NRC) regulates the construction and operation of all new commercial nuclear power facilities that produce electricity in the United States. The NRC is responsible for issuing standard design certifications, early site permits, construction permits, operating licenses, and combined licenses for commercial nuclear power facilities. NRC regulates reactor siting, construction, operation, and decommissioning through a combination of regulatory requirements, licensing, and oversight, including inspection. Recently, the NRC has been making minor revisions in its policies to help make new licensing reviews more effective and efficient and to reduce unnecessary regulatory burden on future applicants. NRC's Regulations

## **Pre-Publication Draft – Subject to Change**

are found in Chapter I of Title 10, "Energy," of the Code of Federal Regulations (CFR). These are summarized in Appendix 3.

### **5.4.1 Disturbance**

As with the other energy options discussed, construction of the Toshiba 4S reactor in Galena would require a storm water permit under EPA's NPDES program. Depending on the area of land disturbed (including security fences, etc.), additional disturbance-related regulations may be invoked, including those listed in Table 4-1 for Coal Mining.

### **5.4.2 Air Pollution**

The Toshiba 4S power plant is an entirely closed system. As such, no atmospheric emissions are anticipated under normal operating conditions. Any air permitting issues associated with the 4S plant will likely be routine nonradioactive emissions permits through the Alaska Division of Air Quality.

### **5.4.3 Water Pollution**

As with air pollution, the closed system design of the 4S plant will likely limit water pollution permitting to the construction storm water permits described above under "disturbance."

### **5.4.4 Waste Management**

Operation of the 4S reactor will generate small volumes of solid waste (trash) and potentially some small volumes of hazardous (nonradioactive) wastes. Both classifications will be permitted as described for the other energy options listed above. Under the assumptions provided by Toshiba, the 4S plant will not generate any radioactive waste except the reactor core itself, which will be returned to Japan following the decommissioning of the plant.

## **5.5 Conclusions – Environmental Issues and Permitting**

Given the assumptions stated throughout this report, and strictly from an environmental permitting standpoint for the City of Galena, evaluation of the permitting requirements for each of the three primary energy options yields a clear loser (coal) and an apparent winner (nuclear). Two key assumptions that play heavily into this result. The first is that coal will be generated locally. This represents a distinct disadvantage from a permitting standpoint in that permitting for the mine site must be considered for this option, but not the others. The second assumption is that all of the information provided to us by Toshiba proves to be accurate and is accepted by the NRC. Specifically, (1) if the 4S reactor truly generates no air or water emissions; (2) the reactor is returned to the final assembly point the end of its useful lifetime (thereby eliminating

## Pre-Publication Draft – Subject to Change

nuclear waste issues in Alaska), and (3) Toshiba<sup>5</sup> bears all (or most) of the licensing costs, then the permitting “cost” to Galena is reduced to the point that the nuclear power option becomes the clear preference. Before a final decision is made, it is imperative that these assumptions be verified.

### 6. ECONOMIC ANALYSIS

#### 6.1 Overview of Methodology

The economic analysis model calculates the total cost of providing electric power to the Galena utility distribution system (the “busbar cost”). The analysis runs for 30 years, from 2010 to 2039. In all cases, the existing electric and district heat loads are served as firm loads. In some cases, additional heating loads are also served, and the delivered energy is valued at the avoided cost of displaced fuel. Electric space heating of residences is treated as a firm load, which must be met by the utility with diesel backup, while the air station heating load is treated as a nonfirm or “economy energy” load.

The model computes and considers the relevant electric and heat loads one day at a time to determine how much energy can be delivered that day by the primary generation source (diesel, coal, or nuclear) and how much must be delivered from diesel as a peaking and/or backup resource. Nonfirm energy sales are counted as a credit against total energy production cost to determine the net cost of serving the firm load. The model calculates the net present value of all annual costs to determine the total system life-cycle cost of power generation to the City of Galena Electric Department. It also computes the approximate average electric rate necessary to cover each year’s annual cost of providing electric service. The average electric rate also includes estimated distribution and administration costs.

To deal with uncertainty, we employ low and high values for some critical parameters. These are discussed below. We also employ sensitivity analysis to determine the effect of changing some specific assumptions.

##### 6.1.1 Example of Model Structure

The following highly simplified example illustrates the basic steps in the analysis. More details on the model structure are presented in Appendix D. The full model is available from the authors as an Excel spreadsheet.

Suppose the total firm load to be served on January 1, 2010, is one megawatt (1 MW) of electricity (measured at the busbar) and the primary generation resource is diesel.

The busbar energy requirement for that day is  
 $1 \text{ MW} \times 24 \text{ hours} = 24 \text{ megawatt-hours (MWh)},$

The amount of diesel required is  
 $24,000 \text{ kWh} / (14 \text{ kWh/gallon}) = 1,714 \text{ gallons/day}.$

where 14 kWh/gallon is the assumed efficiency of the diesel generators.

---

<sup>5</sup> Toshiba or the third party owner

## Pre-Publication Draft – Subject to Change

The cost of this fuel is

$$1,714 \text{ gallons times } \$2.50 / \text{gallon} = \$3,685/\text{day}$$

Additional variable operating costs (such as lube and overhauls) are

$$24,000 \text{ kWh} \times \$0.02/\text{kWh} = \$480/\text{day}$$

The total variable cost of generation for this one day is

$$480 + 3,685 = \$4,165/\text{day}$$

The total variable cost for other days differs because more or less electricity is produced. The model adds all of these daily variable costs together; the total variable cost for one year might therefore be about \$1.2 million.

The annual fixed cost is

$$\$300,000 \text{ (for labor)} + \$200,000 \text{ (for generation equipment)} = \$500,000$$

Therefore the total annual cost of generation for the year 2010 is \$1.7 million. If the total cost of the distribution system and utility administration is \$500,000 per year, then the total cost of electric service for the year is \$2.2 million.

Total electric sales are projected to be

$$9,440 \text{ MWh} \times 0.9 = 8,496 \text{ MWh},$$

where the factor 0.9 accounts for 10% losses between the point of generation and the customers' meters.

To cover the total cost of generation, the average rate must be

$$\$2,200,000 / 8,496,000 \text{ kWh} = \$0.26 / \text{kWh}$$

Of this, 18 cents per kWh is for generation and the remaining 8 cents per kWh is for distribution and administration. In this simple example, the entire load is a firm load. In subsequent years, the load grows and costs increase. The required electric rate may go up or down over time. The life-cycle cost of electric service is the discounted present value of all annual costs.

This simplified example does not consider the economics of serving additional heat loads. Sales of additional heat or electricity beyond the current utility requirements would be counted as a credit against the total cost of the energy system. The details of how this analysis plays out are considered below, in the results section.

### 6.1.2. Economic Model Limitations

The economic analysis is based on the comparison of scenarios for change occurring 30 years into the future. While scenario analysis is a useful tool for examining long-range feasibility, it does have several limitations.

## Pre-Publication Draft – Subject to Change

1. the validity of the analysis depends on the validity of the scenarios and the assumptions that are used to generate them.
2. the analytical model does not contain internal "feedbacks" such as an explicit link between higher electricity prices and reduced electricity consumption.
3. we have not attached probabilities to any of the assumptions or scenarios. Therefore the model cannot produce estimates of a single "most likely" or "best" estimate for any of the results.
4. finally, no attempt has been made to explicitly evaluate the degree to which any of the options may increase or decrease economic and financial risk.

In summary, our scenario-based analysis requires the reader of the report to make their own judgments about which scenarios and assumptions are more likely to occur. Although this can be viewed as a limitation of our method, it can also be viewed as a strength, since there is a clear link between assumptions and conclusions for each scenario examined.

## 6.2 Assumptions

### 6.2.1 Overview of Assumptions and their Use

The analysis period runs for 30 years, starting in 2010. This is the first year in which the nuclear or coal systems could plausibly be put in place. All dollar values are "real" dollars with today's (year 2004) purchasing power. The discount rate for computing the net present value of future dollar amounts is assumed to be 4% over and above inflation. This is consistent with interest rates for public-sector borrowers such as the City of Galena.

Numerous assumptions drive the analysis. Some are more important than others, and some are more uncertain than others. Some assumptions are both very important and fundamentally uncertain. We have designated these as *critical assumptions*. The five critical assumptions for this analysis are

- 1) the initial price of diesel in 2010,
- 2) the future increase in the price of diesel,
- 3) the price of coal,
- 4) the efficiency of the coal plant, and
- 5) the number of security staff needed at the nuclear plant.

Each critical assumption has a low value and a high value, which are presented below and summarized in **Table 6.1**. Combinations of low and high values for the five critical assumptions jointly determine the basic range of results. We have made no attempt to choose a "most likely" value or an "average value" for any of the critical assumptions.

## Pre-Publication Draft – Subject to Change

**Table 6.1.** Summary of critical assumptions

	units	low value	high value
Diesel fuel price in 2010	\$/gallon	1.50	2.15
Diesel fuel price increase (over and above general inflation)	% per year	0.0%	2.0%
Coal price (delivered to Galena)	\$/ton	100	125
Coal plant average efficiency		30%	40%
Nuclear plant security staff	positions	4	34

For all other assumptions, we have adopted single values for the basic analysis. These are presented and discussed in the following sections. Sensitivity cases explore some variation in these other assumptions, which are discussed in the results section, below.

### 6.2.2 Current Loads and System Costs

Galena electric energy requirements have been growing at about 2% per year, reaching about 9.5 MWh in 2003. Generation efficiency has also increased and is now close to 14 kWh per gallon. The current cost of providing electric service is about 26 cents per kWh, as shown in **Figure 6.1**. As this figure shows, about one-third of the total cost is for distribution and administration. To be competitive with diesel, an alternative generation system must deliver electricity to the distribution system for about 18 cents per kWh.

**Table 6.2.** Galena electric utility statistics.

	units	FY00	FY01	FY02	FY03	Average annual growth
Electricity generated	MWh/yr	9,026	9,141	9,408	9,578	2.0%
Electricity sold	MWh/yr	8,038	8,531	8,342	8,103	0.3%
Diesel fuel used	gallons	667,815	662,908	686,104	692,932	1.2%
Peak load	MW				1.6	
kWh generated per gallon		13.5	13.8	13.7	13.8	0.8%
Electric losses		10.9%	6.7%	11.3%	15.4%	
District heating load	B Btu/yr				8.0	

source: City of Galena

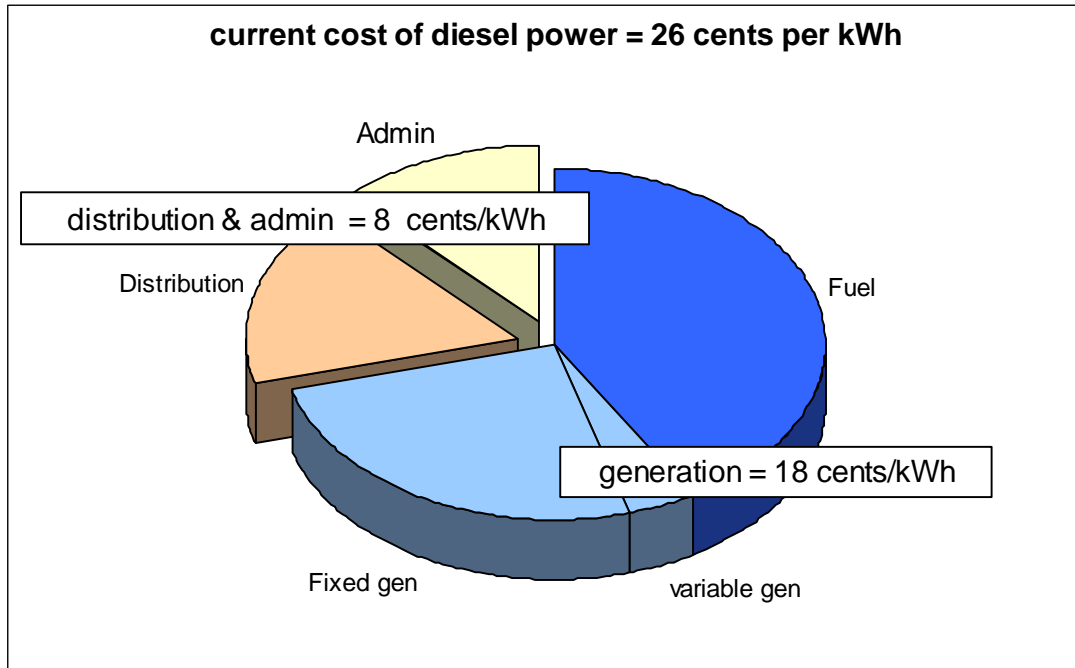


Figure 6.1. Current cost of electric service with diesel fuel at \$1.32/gal for 2003, the year of this data.

### 6.2.3 Assumptions about Future Loads

Table 6.3 and Figure 6.2 summarize our projections of future energy requirements. We assume that current utility electricity requirements will continue to grow at 2% per year. The existing district heating load remains constant and is treated as a firm load. Both the coal and nuclear systems must serve this load.

Table 6.3. Future energy requirements.

source of load	type	units	2010	2039
Utility electricity	firm	MW h	11,002	19,539
Existing city heating loop	firm	MW h	2,344	2,344
Residential space heating	firm	MW h	7,413	13,164
Air station heat	non-firm	MW h-equiv	8,464	8,464
Greenhouse	firm	MW h	570	570
<b>Total energy requirements at power plant</b>		<b>MW h</b>	<b>29,794</b>	<b>44,081</b>

note: MW h-equiv denotes the amount of electricity that could be generated by passing the heat load in question through a turbine/generator.



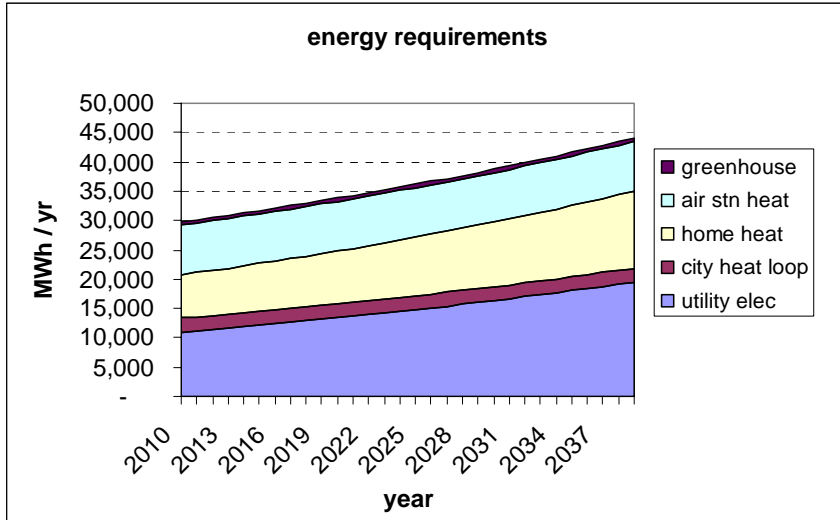


Figure 6.2. Projected future energy requirements.

Table 6.4. shows additional assumptions about the residential space heating load and the air station district heat load. We have estimated the home space heating load to be about 7.4 MWh in 2010, based on 220 houses each using the equivalent of 1,000 gallons of stove oil per year. This home space heating load is also treated as a firm load. However, our analysis revealed that it does not make economic sense to try to serve any of this load with electricity generated from diesel or coal. Therefore, home electric space heating is only provided by the nuclear system. It is valued at the avoided cost of stove oil, which we assume costs 75 cents more per gallon than utility diesel. Partially offsetting these savings are the costs of upgrading the distribution system and installing electric baseboard heating in all existing homes.

The air station heat load is assumed to remain constant at 52 billion Btu per year (B Btu/yr). To analyze this load in the context of the electric system, we have expressed this load in terms of how much electricity could be produced with the heat energy.<sup>6</sup> The air station heat load is nonfirm. The nonfirm heat sales are treated as economy energy sales of steam or hot water metered at the power plant. In the model, these sales are not backed up with diesel power when the coal or nuclear systems are down. The coal or nuclear power plant is assumed to be sited near the current power plant, resulting in a 2-mile distance to the air station. The capital cost of installing this heat distribution pipe is deducted from the fuel savings measured at the air station when calculating the benefits of providing this heat.

<sup>6</sup> We assume a 50% conversion efficiency in the turbine/generator system. A 52 billion Btu/yr thermal load can also be expressed as 15,235 MWh of heat energy. This heat energy could be converted at 50% to 7,618 MWh of electric energy. Adjusting this figure for 10% heat losses in the heat delivery pipe, we arrive at a figure of 8,464 MWh-equivalent. It takes the same fuel resources to provide 52 billion Btu to the distant end of a heating pipe as it does to produce 8,464 MWh of electricity at the busbar.

## Pre-Publication Draft – Subject to Change

**Table 6.4.** Assumptions about heating loads.

<b>Residential Space Heat</b>		
number of houses, year 2010		220
annual growth in number of houses		2.0%
stove oil consumption per house	gallons/yr	1,000
residential furnace efficiency		75%
residential fuel price premium (delivery c	\$/gallon	0.75
Utility line upgrades capital cost	\$	800,000
customer premises upgrade cost	\$/house	3,000
electric dist'n loss from busbar to house		10.0%
<b>District Heat</b>		
Current district heat load	B Btu/yr	8.0
Cost of bulk distribution pipe	\$/foot	200
Air station boiler efficiency		80%
Distance from power plant to air station	miles	2.0
district heat loss in pipes		10.0%
Heat load factor (based on HDD data)		0.51
Heat sales tariff as % of net avoided cost		75%

### 6.2.3 Assumptions about the Diesel System

**Table 6.5** summarizes our assumptions about the diesel system. The main technical assumption is that starting in 2010 new units will be rotated into the system such that the overall generation efficiency is 15 kWh per gallon. We assume that this figure then remains constant throughout the analysis. This is a simplification of what would actually be a gradual improvement in efficiency over time.

The main economic assumption underlying the cost of diesel generation is the price of fuel. The low projection for diesel fuel prices is constant (in real dollars) at \$1.50 per gallon. Historically, utility diesel prices have actually been constant or declining for significant periods during the past 30 years when measured in real dollars. The high assumption is that diesel fuel prices start at \$2.15 per gallon (in today's dollars) in year 2010, then increase at 2% per year over and above inflation. Since the cost of crude oil represents only about 30% of the cost of delivered diesel fuel, this assumption of 2% diesel price growth corresponds to a 7% annual growth in real crude oil prices. Crude oil prices could rise to over \$300 per barrel (in today's dollars) by 2039 and still be consistent with this scenario. Of course, numerous other factors -- such as carbon taxes or increasing costs of tank farm storage -- could also contribute to increased prices.

**Table 6.5.** Assumptions about the diesel system.

	units	selected value (yr 1)	low value	high value
<b>Diesel capital cost</b> (replace engines)	\$/kW	400		
<b>Diesel Fuel</b>				
Utility fuel initial price	\$/gallon	1.50	1.50	2.15
Annual real escalation	% per yr	0.0%	0.0%	2.0%
Utility initial fuel efficiency	kWh/gal	14		
kWh measured at busbar				
Efficiency of New Units	kWh/gal	15		
<b>Nonfuel diesel O&amp;M</b>				
Diesel generation labor	\$/year	305,157		
Variable O&M (includes overhauls)	\$/kWh	0.017		

## Pre-Publication Draft – Subject to Change

If the diesel system is run as the primary generation source, we assume that capital replacements would be required such that every seven years new capacity equal to the current peak load for that year is added to the system to replace old units and to expand overall capacity consistent with load growth. Engine overhaul costs are subsumed into the assumed variable O&M cost of 1.7 cents per kWh. The capital cost of possible incremental fuel storage is not considered. The maintenance cost of fuel storage is included in the variable O&M cost.

Note that for all systems considered, a diesel generation capability is retained to serve as backup for times when the primary production facility is down for maintenance or emergencies.

### 6.2.4 Assumptions about the Coal System

**Table 6.6** summarizes our assumptions about the coal system. It is important to recognize at the outset that all of these assumptions are very uncertain. Very few AFBC units have been built at the scale contemplated here (between 1 and 5 MW). The Galena coal resource has not been delineated. Detailed designs that would match the thermal and electrical output of the coal plant to these loads have not been developed. To address this uncertainty, we have designated the coal plant electric generation efficiency and the delivered price of coal as critical assumptions with low and high values.

**Table 6.6.** Assumptions about the coal system.

	units	selected value (yr 1)	low value	high value
<b>Coal plant capital cost</b>	\$/kW	3,000	3,000	not used
<b>Coal plant availability</b>		91%		
<b>Coal plant efficiency</b> (electric output/coal input)		40%	30%	40%
Coal or nuclear "heat to electric" efficiency		50%		
<b>Coal fuel</b>				
Energy content	M Btu/ton	20		
Delivered price of coal	\$/ton	100	100	125
Ash disposal cost	\$/ton	20		
<b>Nonfuel coal O&amp;M</b>				
Coal labor	people	6		
cost per operator	\$/yr	53,200		
variable O&M and consumables	\$/kWh	0.01		

The size of the coal plant is not predetermined. For each set of critical assumptions, we used the model to determine the optimal size for the coal plant. We also determined whether or not it was economic to serve the air station heat load with coal-fired district heat.

### 6.2.5 Assumptions about the Nuclear System

**Table 6.7** presents our assumptions about the nuclear system. In all basic cases, the assumed capital cost to the City of Galena and to ratepayers is zero. For

## Pre-Publication Draft – Subject to Change

the purposes of sensitivity analysis, the assumed capital cost for the 10-MW plant is \$25 million, based the 50MW capital cost assumption of \$2,500 per kW.

Annual supplies and expenses are in addition to labor. Toshiba estimates about \$1 million for this line item for their 50-MW plant. Since the reactor is sealed, these expenses probably relate almost exclusively to the steam piping and turbine/generator systems. Although the components would be smaller, it does not seem plausible that consumables costs for a 10-MW plant could drop to one-fifth of those for 50 MW. Some of these costs probably do not change at all. Lacking specific data on this point, we have assumed that annual supplies and expenses are one-half the amount estimated by Toshiba for the 50-MW design.

Decommissioning costs are not considered in the analysis, under the assumption that they would be borne by the plant owner or some other party.

**Table 6.7.** Assumptions about the nuclear system.

	units	selected value (yr 1)	low value	high value
<b>Nuclear capacity</b>	MW	10.0		
<b>Nuclear capital cost</b>	\$	0		
Nuclear security staff	people	34	4	34
Nuclear operator staff	people	8		
Nuclear availability		95%		
Nuclear annual supplies and expenses	\$/yr	500,000		

## 6.3 Economic Analyses Results

### 6.3.1 Basic Results

The basic results presented in this section come from varying only the five critical assumptions. Additional sensitivity cases are discussed in the following section.

#### 6.3.1.1 Diesel

The total life-cycle cost of power generation with diesel ranges from \$38 million to \$59 million. This range results solely from variation in the future price of diesel fuel. **Figure 6.3** shows that electric rates (in inflation-adjusted dollars) could go down if fuel prices stay flat, or they could rise significantly under the high fuel price assumption. The projected electric rates are determined by adding estimated distribution and administration costs to the cost of power generation. Total distribution costs are assumed to increase with the number of households (2% per year) while total administration costs are assumed to remain constant. Electric rates go down slightly under the assumption of low and flat diesel prices because the constant total cost of administration gets spread over more and more kilowatt-hours.

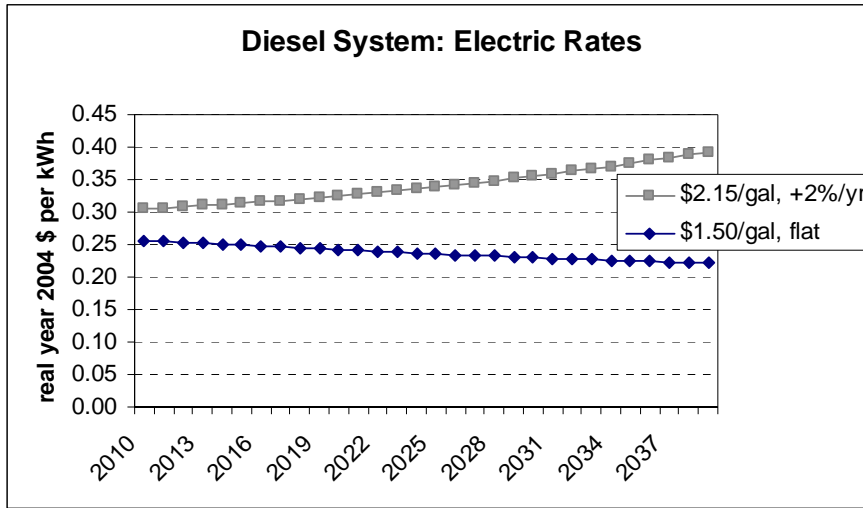


Figure 6.3. Projected future electric rates with diesel system.

### 6.3.1.2 Coal

The total life-cycle cost of power generation with coal ranges from \$23 million to \$35 million. The low cost of \$23 million results from a combination of high diesel fuel prices, low coal prices (\$100/ton), and high (40%) coal plant efficiency. Under these conditions, it is economic to serve the air station heat load with district heat. Almost \$20 million worth of fuel oil costs can be avoided, which more than justifies a \$2 million capital expenditure to build a distribution pipe from the power plant to the air station. The optimal size of the coal plant under these assumptions is 4.0 MW, which is sufficient to meet all peak loads in 2010, as shown in **Figure 6.4**.

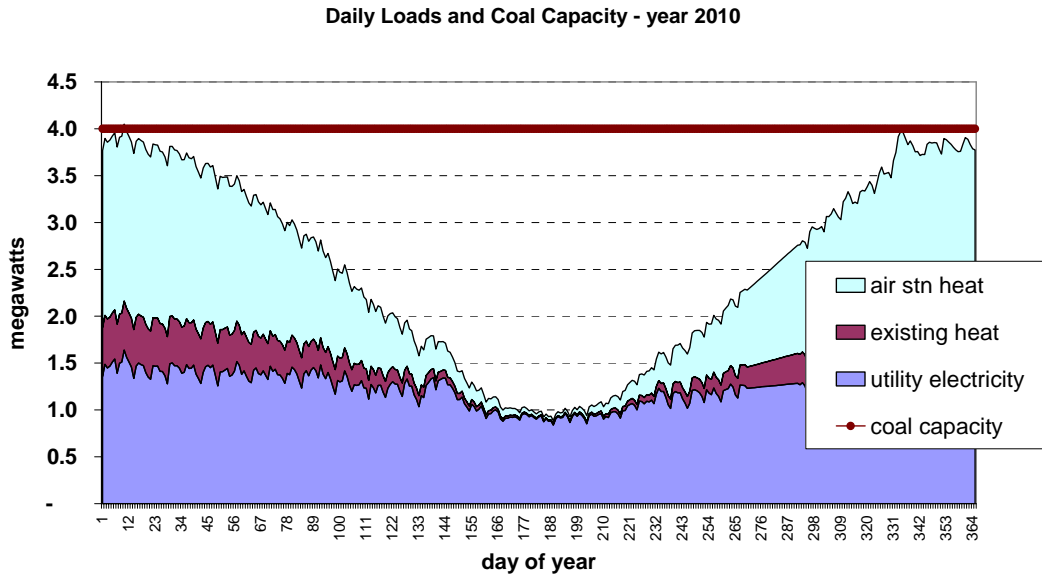
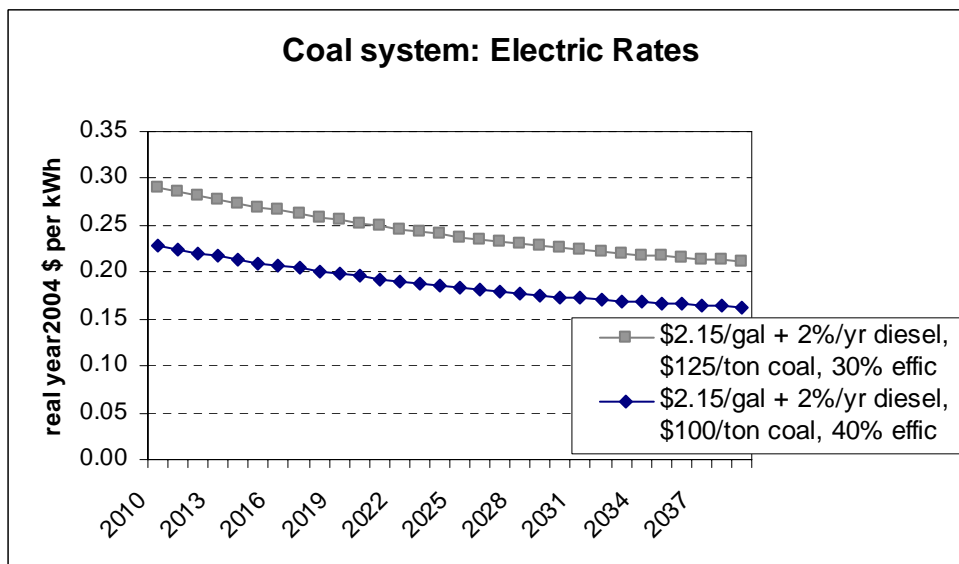


Figure 6.4. Coal plant capacity vs. daily loads for high diesel prices.

The net cost of power generation from a coal system is highest when diesel prices are high, coal prices are high (\$125/ton), and coal plant efficiency is low (30%). Under these conditions, it is still economic to serve the air station heating load and the optimal size of the coal plant drops only slightly, to 3.8 MW. However, the higher cost of coal drives up the overall cost of power. Figure 6.6 shows projected electric rates corresponding to the two scenarios just discussed.



# Pre-Publication Draft – Subject to Change

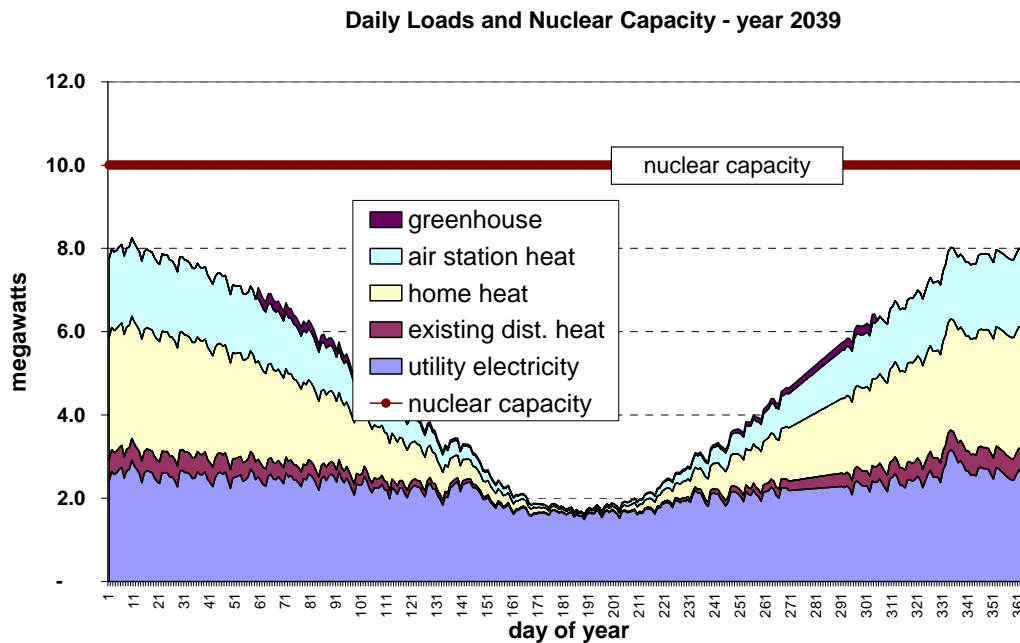
**Figure 6.5.** Projected future electric rates with coal system

Although the absolute cost of the coal system varies by only \$12 million, it is important to note that the net benefits from coal relative to diesel vary by much more. When diesel prices are high and coal prices are low, the coal system costs \$36 million less than diesel. When diesel prices are low and coal prices are high, the coal system costs only \$3 million less than diesel. However, in all cases, the coal system costs less than diesel under the assumptions used here.

### 6.3.1.3 Nuclear

Inspection of the projected daily load curves shows sufficient nuclear capacity to meet all the potential electric and heating loads at all times during all years. (Some diesel power is still required during times of unavailability.) This is demonstrated in **Figure 6.7**, which compares daily loads to nuclear system capacity for the year 2039, when loads are highest. This figure also shows the large amount of heat energy that can be provided in a way that displaces expensive diesel fuel and generates revenue for the utility. Revenue from heat sales can be applied against the total cost of all utility service to drive down consumer electric rates.

The total life-cycle cost of providing power with the assumed nuclear system ranges from *minus* \$7 million to [plus] \$35 million. The low figure occurs when diesel prices are high and the required security staff is low (4 people). The total cost of electric generation at the busbar is negative because the avoided cost value of heat sales to the air station and to residential customers is more than enough to pay for the total cost of serving *all* loads. Therefore the remaining cost to be allocated to the provision of nonheat electricity is negative.

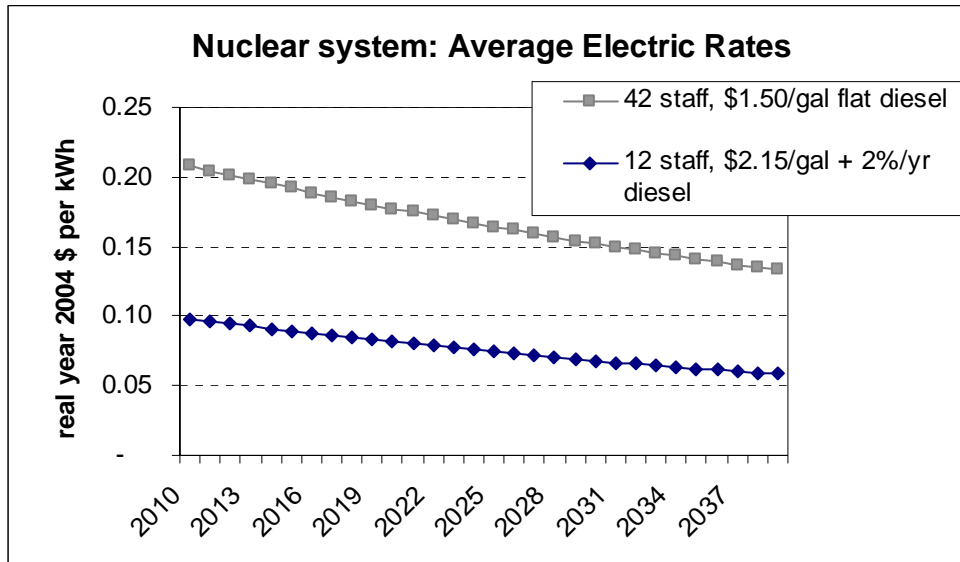


**Figure 6.6.** Daily loads vs. nuclear capacity, year 2039.

## Pre-Publication Draft – Subject to Change

This result does not mean that electric rates can be negative. There are two reasons for this. First, even if the total cost of electricity generation was minus \$7 million, there is also a total life-cycle cost of about \$14 million for distribution and administration. This would yield a net life-cycle revenue requirement of \$7 million that would have to be covered by rates. Second, actual sales of electric space heat and air station district heat are unlikely to take place at a price equal to the buyer's avoided cost. The actual price will surely "split the savings" between the utility and the heat customers. In calculating projected electric rates, we have assumed that air station heat will be sold, on average, for about 75% of its avoided cost value. For both of these reasons, the projected average electric rate when nuclear costs are lowest declines over time from 10 cents per kWh to 6 cents per kWh.

The life-cycle cost of power generation from nuclear is highest, at \$34 million, when diesel prices are low and when the required number of security staff is high (34 people). This cost is still \$3 million below the comparable cost of diesel power. Under these conditions, the avoided cost value of electric heat and district heat is much lower and the absolute cost of running the nuclear plant is much higher due to labor costs. The projected average electric rates decline over time from 21 cents per kWh to 13 cents per kWh. In this case, it would be necessary to offer a special rate for electric heat, since with low diesel prices the avoided cost of oil heating would equate to only about 7.5 cents per kWh. Even with special rates for electric heat, it is important to remember that customers would pay less for their core (nonheat) electricity than they would with diesel.



**Figure 6.7.** Projected future electric rates with nuclear system.

### 6.3.1.4 Summary of Basic Results.

**Table 6.8** summarizes the results described above. The ranges shown for costs and rates come from varying only the five critical assumptions.



## Pre-Publication Draft – Subject to Change

**Table 6.8.** Summary of basic results.

	Diesel	Nuclear	Coal
Loads served:			
utility electricity	X	X	X
existing district heat	X	X	X
residential electric space heat		X	
greenhouse		X	
air station district heat		X	[sometimes]
Life-cycle total cost (\$million)			
low value	38	(7)	23
high value	59	35	36
Net benefits compared to diesel (\$million)			
low value		3	3
high value		67	36
Average electric rate in 2010 (\$/kW h)			
low value	0.26	0.10	0.23
high value	0.30	0.21	0.29
Average electric rate in 2030 (\$/kW h)			
low value	0.23	0.07	0.17
high value	0.36	0.15	0.23

### 6.3.2 Special Sensitivity Cases

In this section, we report the results of several sensitivity cases. These cases address two questions that are a natural outgrowth of the basic analysis. The first question is, how does the analysis change if nuclear capital costs are included? The second question is, how does the analysis change if the nuclear or coal plants were sited 7 miles from the air station rather than 2 miles away.

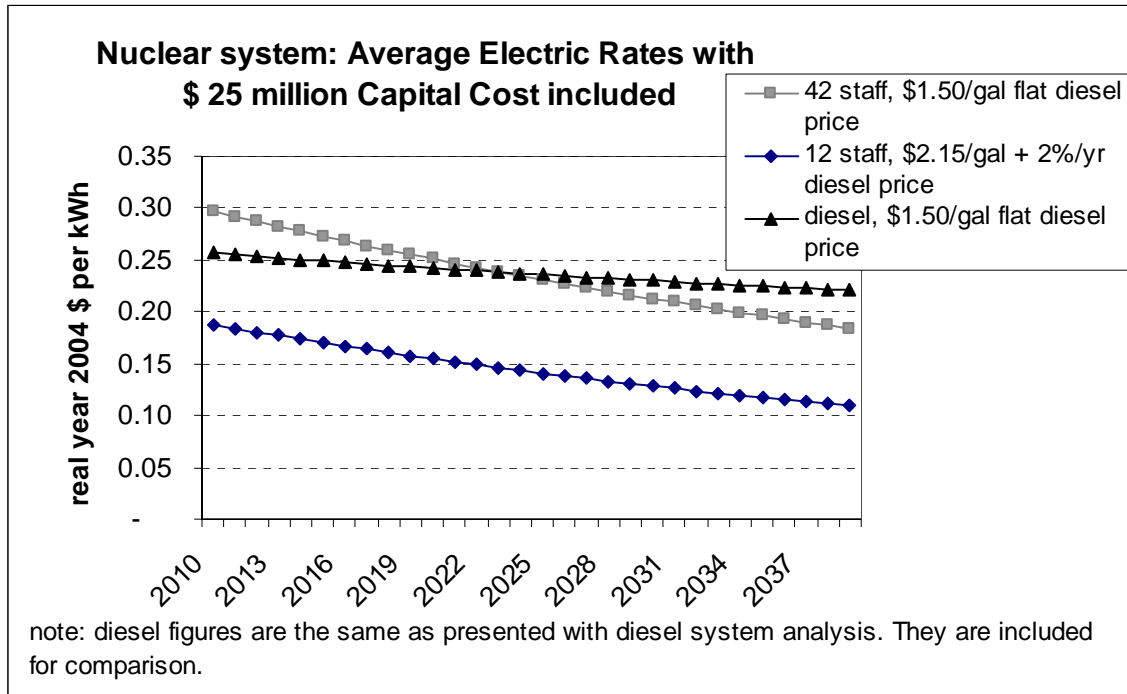
#### 6.3.2.1 Cases with Nuclear Capital Costs Included

Toshiba estimates that the capital cost of its 4S system is \$2,500 per kW, or \$25 million for the 10 MW plant.<sup>7</sup> Using this figure, the life-cycle costs of the nuclear system would increase in all cases by exactly \$25 million. They would range from \$18 million to \$60 million. The impact on average rates is to increase them all by about 9 cents per kWh.

If diesel prices stay low and flat, as in our low critical assumption, then diesel power generation is less expensive than nuclear by \$22 million (life-cycle cost).

**Figure 6.8.** shows that with low diesel prices, average electric rates would be comparable between nuclear and diesel. However, as discussed above, lower rates would be needed for electric heat and rates for nonheat electricity would be higher than this average. Ratepayers would clearly be better off with diesel if diesel prices stay flat and nuclear capital is included in rates and a large security staff is required.

<sup>7</sup> Toshiba presented this estimate with slides describing the 50-MW plant. We have used the cost per kW figure and applied it to the smaller size. Due to economies of scale, this approach may understate the cost of the smaller, 10-MW plant. However, we are unaware of a direct cost estimate for the 10-MW size.



**Figure 6.8.** Projected future electric rates with nuclear capital costs included in rates.

If diesel prices are high, rising at 2% per year from a base of \$2.15 per gallon, and if the nuclear plant requires only a small security staff, then the life-cycle cost of power generation from nuclear would be \$41 million lower than the cost of diesel and electric rates would be dramatically lower.

These sensitivity cases demonstrate that if a \$25 million capital cost is included in the analysis, the nuclear system is not always a clear winner. There are many combinations of slowly rising diesel prices and high staffing requirements that would make nuclear more expensive than diesel or coal. If the analysis were being done for another community, the rankings would also depend strongly on the size and nature of the electric and heating loads in that place.

### 6.3.2.2 The Effect of Power Plant Location

The basic analysis assumes that the nuclear or coal plant would be sited near the current Galena power plant, resulting in the need for a 2-mile pipe to transport district heat to the air station. If this distance were increased to 7 miles, the capital cost of a heat distribution pipe costing \$200 per foot would increase by \$5.3 million.<sup>8</sup> Under our methodology, this increased capital cost of the pipe would increase the life-cycle cost of power generation by exactly the same amount - \$5.3 million – in all cases where the air station heat load is served.

<sup>8</sup> We recognize that there would also be additional costs in the form of higher heat losses, but for simplicity these are not treated explicitly, since this case is only illustrative. Adding a specific allowance for higher heat losses would be analytically equivalent to postulating an even longer distance with the same losses.

## Pre-Publication Draft – Subject to Change

This increase would not affect the economic attractiveness of the nuclear or coal systems if diesel prices take on the high trajectory, although average rates would increase by about 1 cent per kWh. In particular, with high diesel prices it would still make economic sense for the coal plant to serve the air station. If diesel prices are low and flat, however, and if the nuclear staff is large, then the increased capital cost of heat pipe makes the nuclear system slightly more expensive than diesel. Adding 5 miles of extra distance to the heat pipe is economically equivalent to adding about 6 security staff to the required nuclear labor force.

These sensitivity cases demonstrate that distance from the coal or nuclear power plant matters, but only in a moderate way. Adding distance becomes critical to the economic conclusion only if diesel prices are low and flat. If diesel prices are high and rising, even a 7-mile heat transmission line still makes good economic sense at a \$200/foot construction cost.

### 6.3.3 Transmission

Since the nuclear plant is capable of producing large amounts of electricity in excess of current Galena electric loads, it is natural to consider the economics of building a transmission line to send the excess electricity to neighboring communities. We considered two possible transmission lines. Line A would run from Galena to Koyukuk, Nulato, and Kaltag. The total distance is 83 miles, and the transmitted electricity could displace about 172,000 gallons of diesel per year. We assume that the line could be built for \$80,000 per roadside mile plus \$200,000 per overland mile. The total cost would be \$14.9 million and the net present value of the avoided fuel costs would be \$8.1 million under our high diesel price assumption. Thus, this line would have a net economic cost of \$6.8 million.

The second line we considered was from Galena to Ruby. The distance is 42 miles and the transmitted power could displace 59,000 gallons of diesel per year. The total cost of \$7.3 million would far exceed the avoided fuel costs of \$2.8 million. **Table 6.9** summarizes the transmission analysis.

## Pre-Publication Draft – Subject to Change

**Table 6.9.** Economic costs and benefits of transmission lines.

from	to	segment avoidable diesel gal/yr	segment road miles	segment overland miles	segment cost
<b>Line A:</b>					
Galena	Koyukuk	23,279	5	27	5,800,000
Koyukuk	Nulato	89,448	4	14	3,120,000
Nulato	Kaltag	58,929	5	28	6,000,000
Total line A		171,656	14	69	14,920,000
Present value of avoided costs (assumes high diesel price)					8,147,440
<b>Net economic benefit of line (with free power at Galena)</b>					<b>(6,772,560)</b>
<b>Line B:</b>					
Galena	Ruby	59,180	9	33	7,320,000
Total line B		59,180	9	33	7,320,000
Present value of avoided costs (assumes high diesel price)					2,808,906
<b>Net economic benefit of line (with free power at Galena)</b>					<b>(4,511,094)</b>

### 6.3.4 Economics of hydrogen production

Another potential use for the power generated by the nuclear plant in excess of existing needs is the production of hydrogen. We considered hydrogen production from the point of view of a potential private business enterprise. The enterprise would obtain power from the Galena electric utility and bear the responsibility for all aspects of the hydrogen production process. **Table 6.10** summarizes our analysis of this option.

The potential hydrogen enterprise is assumed to have a higher required rate of return – 7% above inflation. The analysis begins by assuming that electricity is a free input to the production process. There appears to be sufficient local demand for vehicle fuel to fully utilize one hydrogen production module (about 1 MW of electricity input). However, the production cost of hydrogen to meet this demand is extremely capital intensive. Using current costs of commercially available equipment, we estimate that it would cost at least \$6.2 million to construct one production module producing 404,000 gallons of liquid hydrogen per year with an energy content of about 12 billion Btu (Keenan, 2004). When modest operating costs are added, the total annual cost of energy is about \$46 per million Btu, which far exceeds the target cost of diesel or gasoline for vehicle and equipment use. This target cost is about \$17 per million Btu under the high diesel price assumption, rising over time to about \$30 per million Btu. This conclusion is based on almost full utilization of the capital equipment to serve local demands. In other words, there is no “excess capacity,” and it would not make sense to produce additional hydrogen and ship it by barge to a community like Fairbanks that has lower fuel costs.

## Pre-Publication Draft – Subject to Change

**Table 6.10.** Hydrogen enterprise analysis.

Variable	Unit cost, or # of units, or units	present value cost	Year	
			1 2010	30 2039
<b>Real discount rate for enterprise venture</b>	7.0%			
<b>Capital Cost:</b>				
H2 generator (900 kW e input, 150Nm <sup>3</sup> /hr output))		1,500,000		
H2 liquefier (150 Nm <sup>3</sup> and 175 kW e input)		2,000,000		
Storage tanks unit cost, per 50,000	500,000			
Number of storage tanks	1			
Storage tanks capital cost		500,000		
Shipping tnks unit cost 17k gal ea	450,000			
Number of shipping tanks	1			
Shipping tanks capital cost		450,000		
Nitrogen liquefier		700,000		
Filling station equipment, contingency		1,000,000		
<b>Total Capital per Gasifier</b>		6,150,000		
<b>Electricity</b>	0.000	\$/kWh	-	-
<b>O&amp;M on gasifier &amp; liquefier</b>		\$/yr	\$153,682	85,000
<b>Labor on gasifier, liquefier, and storage</b>		\$/yr	\$620,452	50,000
<b>Total liquid H2 production</b>		gal/yr	404,000	404,000
Energy content of liquid H2 Btu/gal	30,000			
Total Energy in liquid H2 form		billion Btu	12.12	12.12
<b>Local demands and export availability</b>		gallons	Btu/gal	billion Btu
City vehicle demand	15,000		114,100	1.7
Schools vehicle demand	25,000		114,100	2.9
Military vehicle demand	50,000		138,000	6.9
Total local demand		billion Btu		11.5
Total local demand		gal H2		382,133
Supply to local market		gal H2		382,133
Available for Export		gal H2		21,867
<b>Amortized production cost</b>				
Amortized capital including return			495,606	495,606
Amortized (smoothed) O&M			12,385	12,385
Labor			50,000	50,000
Electricity			-	-
<b>Total amortized cost</b>			<b>557,991</b>	<b>557,991</b>
Amortized cost per gallon H2 of local demand			1.46	1.38
<b>Amortized cost per million Btu</b>			<b>48.67</b>	<b>46.04</b>
Target cost per million Btu			12.00	12.00

Nearly the entire cost of hydrogen production is the cost of capital equipment. If this capital could be secured with a grant or other external funding source, the operating cost of producing hydrogen would likely be low. A sensitivity case shows that with zero capital cost, a hydrogen enterprise could afford to pay about 1.5 cents per kWh for electricity and still produce hydrogen at a cost per million Btu comparable to diesel or gasoline.

## 7. CONCLUSIONS

### 7.1 Economics Conclusions

Under the assumptions presented above, the nuclear system is the clear economic winner when compared to diesel, even when diesel prices are low and nuclear security staff requirements are high. This result is due to the ability of the 10-MW nuclear plant to serve the entire residential heat load (about 8,000 MWh/yr and 2.3 MW peak) and the entire air station heat load (52 B Btu/yr). We have used a daily dispatch model to verify that nuclear capacity is always adequate to meet daily energy requirements for both of these large loads. When the nuclear plant is unavailable, the air base can back up its own heat load and the Galena diesel system can almost surely back up the Galena residential heat load.

The nuclear system also beats coal on economic grounds in every basic case except one. If diesel prices are low *and* coal prices are low *and* coal efficiency is high *and* the total required nuclear staff is 42 people (8 operators plus 34 security), then the coal system has a life-cycle cost that is \$7 million below that of nuclear.

Coal is attractive relative to diesel in all of the basic cases. It must be stressed that the critical assumptions about coal prices and coal plant capital costs, fuel costs, and efficiency are perhaps the most uncertain, and they all matter. Having said that, when diesel prices are high and rising, the coal system is very likely to produce less expensive power for Galena customers than diesel.

Sensitivity cases show that if a \$25 million capital cost is included in the analysis, the nuclear system is not always a clear winner. When capital charges are included, many combinations of slowly rising diesel prices and high nuclear staffing requirements would make nuclear more expensive than diesel or coal. The amount of potential electricity demand would also be a critical factor in system economics if the nuclear system were to be considered for a community other than Galena. Siting the nuclear or coal plants farther from the air station heat load has a similar but smaller direct effect on system costs. For Galena, this variation in distance is only important if diesel prices remain low.

**Table 5.11** supports these conclusions with a comprehensive summary of all cases considered in this analysis. The first six cases are the basic results that come from varying only the critical assumptions. The second six cases report the same results, but include an additional \$25 million capital cost for the nuclear system. The final four cases document the effect of siting the nuclear or coal plants 7 miles from the air station.

## Pre-Publication Draft – Subject to Change

**Table 7.1.** Summary of basic cases and sensitivity cases.

case code	diesel price	coal price	coal average efficiency	coal capacity MW	nuclear capital charges	nuclear staff	total present value cost \$ million		
	\$/gal	\$/ton					diesel	nuclear	coal
<b>basic cases (varying the critical assumptions)</b>									
lhllh	1.50	125	30%	1.3	0.0	42	37.8	34.6	35.2
llhh	1.50	100	40%	2.1	0.0	42	37.8	34.6	27.5
llhl	1.50	100	40%	2.1	0.0	12	37.8	7.0	27.5
hhllh	2.15	125	30%	3.8	0.0	42	59.3	20.2	35.5
hlhh	2.15	100	40%	4.0	0.0	42	59.3	20.2	23.1
hlhl	2.15	100	40%	4.0	0.0	12	59.3	(7.4)	23.1
<b>sensitivity cases - nuclear capital included</b>									
lhllh	1.50	125	30%	1.3	25.0	42	37.8	59.6	35.2
llhhh	1.50	100	40%	2.1	25.0	42	37.8	59.6	27.5
llhhl	1.50	100	40%	2.1	25.0	12	37.8	32.0	27.5
hhllh	2.15	125	30%	3.8	25.0	42	59.3	45.2	35.5
hlhhh	2.15	100	40%	4.0	25.0	42	59.3	45.2	23.1
hlhhl	2.15	100	40%	4.0	25.0	12	59.3	17.6	23.1
<b>sensitivity - nuclear and coal sited 7 miles rather than 2 miles from air station</b>									
llhh	1.50	100	40%	2.1	0.0	42	37.8	39.9	27.5
llhl	1.50	100	40%	2.1	0.0	12	37.8	12.3	27.5
hlhh	2.15	100	40%	4.0	0.0	42	59.3	25.4	28.4
hlhl	2.15	100	40%	4.0	0.0	12	59.3	(2.1)	28.4

**NOTE:** shaded cells highlight changes in assumptions and results relative to the previous case

Even though installation of the 4S nuclear plant presents a potential long-term solution to Galena's critical energy issues, one must caution that, as with any non-commercialized technology, there is no guarantee. In our view, the most critical issue associated with the adoption of this technology is the difficulty of utilizing liquid sodium as a heat transfer medium. With any nuclear power plant, long-term disposal of radioactive waste is also an issue. If this technology is successfully deployed in Galena, its economic viability in other Alaska villages and elsewhere depends on the actual life-cycle costs yet to be quantified, as well as the actual energy demands in these places.

Benefits associated with adoption of one or more of the technologies discussed in this report go beyond their ability to meet Galena's thermal and electric energy loads. We see the potential for Galena to serve as a training center for rural Alaskans interested in utilizing similar technologies in their villages. We also see the potential for use of additional cogeneration leading to economic development such as the development of horticulture and aquaculture. The enhancement of local employment by these activities is another benefit. With today's uncertain energy situation, many communities are diversifying their energy options. This includes adding renewably based technologies to lessen dependence on fossil fuels. Adding a few tens of kW of PV arrays, for example, could help Galena insulate itself against fluctuations in the price and supply of diesel fuel.

## **7.2 Environmental Issues and Permitting Conclusions**

Given the assumptions stated throughout this report, and strictly from an environmental permitting standpoint for the City of Galena, evaluation of the permitting requirements for each of the three primary energy options yields a clear loser (coal) and an apparent winner (nuclear). Two key assumptions play heavily into this result. The first is that coal will be generated locally. This represents a distinct disadvantage from a permitting standpoint in that permitting for the mine site must be considered for this option, but not the others. The second assumption is that all of the information provided to us by Toshiba proves to be accurate and is accepted by the NRC. Specifically, (1) if the 4S reactor truly generates no air or water emissions; (2) the reactor is returned to the final assembly point at the end of its useful lifetime (thereby eliminating nuclear waste issues in Alaska), and (3) Toshiba (or some other party) bears all (or most) of the licensing costs, then the permitting “cost” to Galena is reduced to the point that the nuclear power option becomes the clear preference. Before a final decision is made, it is imperative that these assumptions be verified.

## **8. RECOMMENDATIONS**

On the basis of environmental permitting, the nuclear plant appears to be a clear winner. The coal mine and power plant option appears to be the most difficult for which to obtain permits. This conclusion is stated with the caveat that this will be determined by the process of gaining a design certification and a license from the NRC.

The economic analysis reveals that the 4S option will provide the lowest cost power if the assumptions hold. In the Galena case, the assumption is that capital cost will be borne by an outside party and that reasonable staffing levels will result from the licensing process. The coal option may be economic in some scenarios compared to enhanced diesel systems, so the coal option should not be entirely discounted.

Therefore, the recommendations are:

- ◆ Proceed with refining the 4S evaluation process in conjunction with the NRC
  - It may be advantageous for Galena to enlist an independent organization to estimate the time required for licensing and permitting
  - Toshiba and Galena should consider partnering with a U.S. organization or National Laboratory to assist in the process
- ◆ Retain the current diesel systems (with scheduled upgrades) until a decision is made regarding the installation of a replacement by about 2010.
- ◆ Retain the option of a coal mine and power plant until it is determined if the 4S system can be permitted and licensed. If the 4S cannot be realized, then the coal option appears feasible (with a favorable coal resource assessment result).



## Pre-Publication Draft – Subject to Change

### REFERENCES

- Bonk, D, US DOE, 2004, Personal communication
- Brown, Neil, Lawrence Livermore National Laboratory, Oct. 4, 2004, private communication
- Brown, K, 1999, Bright Future - or Brief Flare - for Renewable Energy, *Science*, 285, pp. 678-680
- Colt, S., S. Goldsmith, A. Witta, and M. Foster, 2001, Sustainable Utilities in Rural Alaska, prepared for USDA Rural Development.
- Gooley, G.J, Trout, December 1997, The New Rural Industries – A Handbook for Farmers and Investors, Australian Rural Industries R&D Corp.
- Johnson, R., D. Das, D. Witmer, H. Bretas Rueter, 2000, The Creation and Design of an Energy Center, *Jl. of Cold Regions Engineering*, Vol. 14, pp. 13 – 23.
- Keenan, Gregory, June 8, 2004, Air Products Corp., Personal Communication,
- MAFAa, 2002, Rural Alaska Energy Plan, Diesel Efficiency Chapter, prepared for AEA and AIDEA, December 2002
- MAFAb, 2002, Rural Alaska Energy Plan, Cogeneration Chapter, prepared for AEA and AIDEA, December 2002
- MAFAc, 2002, Rural Alaska Energy Plan, End Use Efficiency Chapter, prepared for AEA and AIDEA, December 2002
- McChesney, C, 2003, Arizona PV costs, Environmental Portfolio Standard Cost Evaluation Working Group Cost Committee, UPEX 2003, APS.
- McKinney, M., and R. Schoch, 1998, *Environmental Science*, Jones and Bartlett, Boston, MA.
- NREL, 2004, Solar Radiation Data Manual, <http://www.nrel.gov/>
- Northern Economics, April 2001, Screening Report for Alaska Rural Energy Plan, prepared for AIEDA.

## Pre-Publication Draft – Subject to Change

Northern Resource Group, January 26, 2004, Galena Energy Assessment, Fairbanks, AK.

Petrie, B, 2004, Manager, Special Projects, Alaska Village Electrical Cooperative, Inc, Personal communication.

Phillips, N. and S. Denton, October 1990, Coal Resource and Utilization Survey on Doyon, Lmted. Lands.

Prindle, W. et al, 2003, Energy Efficiency's Next Generation: Innovation at the State Level, Report E 031, <http://aceee.com>.

Ristinen, R and J. Kraushaar, 1999, Energy and the Environment, John Wiley and Sons, NYC.

Royal Academy of Engineering, March 2004, The Cost of Generating Electricity, London, G.B. [www.raeng.org.uk](http://www.raeng.org.uk).

Rosinski, Douglas, May 24, 2004, Shaw Pittman, private communication.

Sackett, John, October 21, 2004, Argonne National Laboratory – West, private communication

Sakashita, Yoshiaki, 2004, Specialist, Advanced Reactor System Engineering Group, Toshiba Corp., Yokohama, Japan, Personal communication.

Scott, D., 2002, Hydrogen System Development – Status and Drivers, 11th Canadian Hydrogen Conference, June 17 – 20, Victoria, B.C.

J.S. Strandberg Consulting Engineers Inc., June 1997, A feasibility analysis of a proposed coal fired thermal power station for McGrath, Alaska. Prepared for MTNT Lmted and McGrath Light and Power,

Triton Consultants, 2002, Green Energy Study for BC, Tidal Current Energy, prepared for BC Hydro.

US Department of Energy, May 2001, Office of Nuclear Energy, Science and Technology, Report to Congress on Small Modular Nuclear Reactors.

Yoder, M, 2004, City Manager, Galena, Alaska, Personal communication,

**APPENDICES**

**APPENDIX A. Presentation by Yoshiaki Sakashita, Toshiba, at the 2004 Alaska Rural Energy Conference, April 27-29, 2004, Talkeetna, Alaska**

# 4S Current Status

4S: *Super Safe, Small & Simple*

2004 Alaska Rural Energy Conference  
Talkeetna, Alaska  
April 27-29, 2004

TOSHIBA Corporation  
Industrial and Power Systems & Services Company

## Contents

### 1. 4S Overview

Features, Plant outline, Target cost,  
Expected schedule, R&Ds

### 2. 4S applications

Fresh water

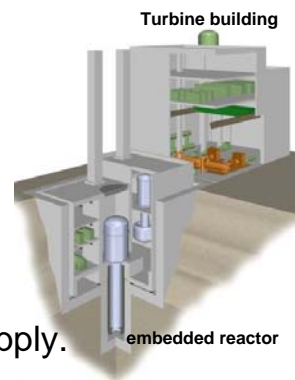
Hydrogen & oxygen

## What is 4S ?

4S power station

### 4S Major Features

- (1) No refueling,
- (2) Passive safety,
- (3) Transportability,
- (4) Reasonable cost for distributed power supply.



## What is no refueling ?

### No refueling means

- (1) Reducing a load of fuel transportation,
- (2) Lower maintenance requirements,
- (3) Non proliferation,
- (4) Design simplification, ex., no refueling device,
- (5) Zero emission during plant lifetime.

### 4S Core

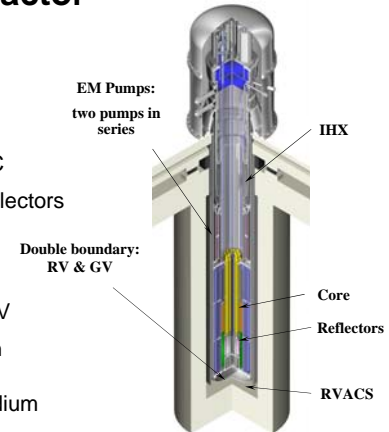
- Fuel material: U-Zr (metallic)
- Coolant material: sodium
- Core lifetime: 30 years
- Core height: 2.5 m (50MWe)  
2.0m (10MWe)
- Core diameter: 1.2m (50MWe)  
0.9m (10MWe)
- Reactivity temperature coefficient: negative



<sup>(\*)</sup> average velocity: 1mm/week approximately

### 4S Reactor

- Output: 10MWe (30MWt), 50MWe (135MWt)
- Coolant: sodium
- Coolant temp: 510 / 355 deg.C
- Reactivity control: movable reflectors
- RV type: integral type
- EM Pumps: annular type
- Core position: bottom in the RV
- RVACS: natural air circulation (Reactor Vessel Auxiliary Cooling System)
- GV: second boundary for sodium (Guard Vessel)

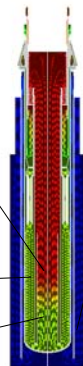


### 4S Primary Cooling System

#### Primary Coolant

Sodium coolant flows inside the reactor vessel by static (EM) pumps.

- Outer region: downward flow
- Inner region: upward flow

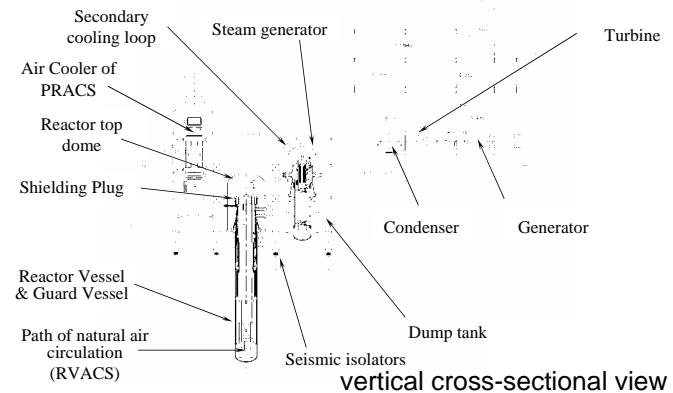


#### RVACS

Natural air circulation around the reactor vessel for decay heat removal



### 4S Plant Arrangement (50MWe)



**TOSHIBA**

## Transportation

Design for shop fabrication, lightweight, and mass production

- Steel beam and autoclaved lightweight concrete
- Steel plate reinforced concrete

**Barge**  
Marine transport

SB & ALC  
SC  
RC

9 / Copyright © 2004 Toshiba Corporation. All rights reserved.

**TOSHIBA**

## Target of Construction Period

Month

Construction periods for laying underground in frozen-soil site should be optimized.

10 / Copyright © 2004 Toshiba Corporation. All rights reserved.

**TOSHIBA**

## Safeguard & Security

For safeguards & security

(1) To minimize unauthorized accessibility to the reactor including fuels by earth-sheltered reactor building.

50MWe (135MWt)  
10MWe (30MWt)

(2) To provide redundancy by two stacks of RVACS.

11 / Copyright © 2004 Toshiba Corporation. All rights reserved.

**TOSHIBA**

## After 30 years

About the decommissioning after 30-year operation

(1) Fuel  
Long-term geologic repository in Yucca Mountain site.

(2) Reactor  
Transport and disposition in accordance with US experience, e.g., Hanford site (Trojan reactor, etc.)

(3) Sodium, buildings & substructure  
Rutilized for next 4S installation.

Reference of the photos; [http://www.nucleartourist.com/systems/rv\\_trip.htm](http://www.nucleartourist.com/systems/rv_trip.htm)

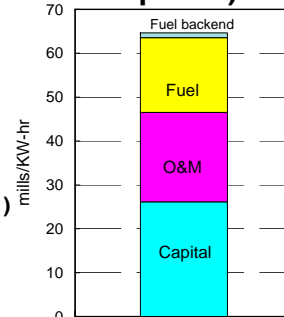
12 / Copyright © 2004 Toshiba Corporation. All rights reserved.

### 4S Preliminary Cost Estimation

50MWe (135MWt) :

Commercial plant (mass production phase)

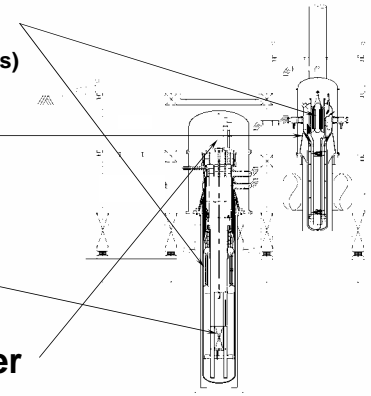
- Plant Construction:  
\$ 2,500/KWe
- Busbar Cost:  
65 mills/KW-hr<sup>(\*1)</sup>



(\*1) 8% house load factor is assumed.

### R&D status for 4S

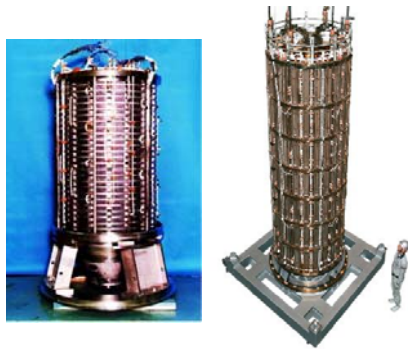
- EM Pumps  
(Electromagnetic pumps)
- SG  
(Steam generator)
- Core
- Reflector Driver



### EM Pumps

Capacity for 4S:  
50m<sup>3</sup>/min (50MWe)

Sodium Test Facility:  
ETEC, U.S.



40 m<sup>3</sup>/min<sup>\*1</sup>

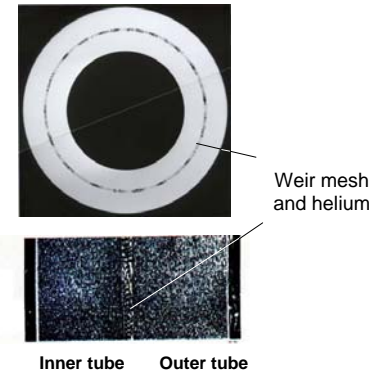
160 m<sup>3</sup>/min<sup>\*2</sup>

<sup>\*2</sup> These R&Ds have been performed as a part of joint R&D projects under sponsorship of the nine Japanese electric power companies, Electric Power Development Co., Ltd., the Japan Atomic Power Company (JAPC) and the U.S. Department of Energy (DOE).

<sup>\*3</sup> These R&Ds have been performed as a part of joint R&D projects under sponsorship of the nine Japanese electric power companies, Electric Power Development Co., Ltd., and JAPC.

### SG

Double wall tube  
with leakage detection system for both inner and outer tubes to prevent a reaction between secondary sodium and water



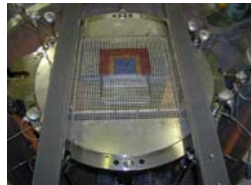
Inner tube Outer tube

<sup>\*2</sup> These R&Ds have been performed as a part of joint R&D projects under sponsorship of the nine Japanese electric power companies, Electric Power Development Co., Ltd., the Japan Atomic Power Company (JAPC) and the U.S. Department of Energy (DOE).

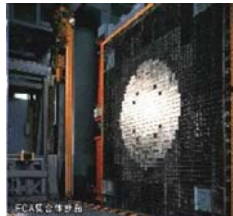
## Core: Critical experiment for 4S

NCA: finished (TOSHIBA)

FCA: 2004 (JAERI)\*1



Toshiba and CEPCO\*2



JAERI, Toshiba, CRIEPI, Osaka Univ.

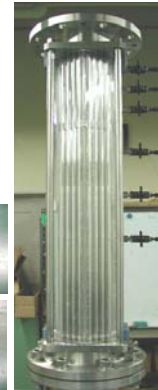
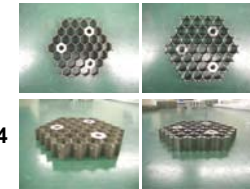
\*1) These R&Ds have been performed as a part of "Innovative Nuclear Energy System Technology (INEST) Development Projects" under sponsorship of MEXT (JAPAN).  
 CRIEPI: Central Research Institute of Electric Power Industry, JAERI: Japan Atomic Energy Research Institute.  
 \*2) CEPCO: Chubu Electric Power Co.,Inc.

## Fuel subassembly

Hydraulic Experiments for high fuel-volume fraction subassembly\*1

CRIEPI and Toshiba

Basic tests: finished,  
 Full-scale mockup: 2003-04



\*1) These R&Ds have been performed as a part of "Innovative Nuclear Energy System Technology (INEST) Development Projects" under sponsorship of MEXT (JAPAN).

## Reflectors (EMI: Electromagnetic Impulsive force drive)

Fundamental test: finished

1/3 model test: 2004-05\*1



Toshiba and CEPCO\*2

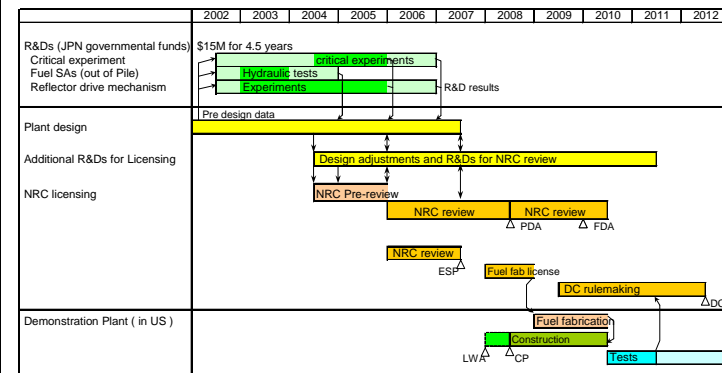
Photo: EMI pre-test module\*1 ; finished



Toshiba, Univ. of Tokyo, and CRIEPI

\*1) These R&Ds have been performed as a part of "Innovative Nuclear Energy System Technology (INEST) Development Projects" under sponsorship of MEXT (JAPAN).  
 \*2) CEPCO: Chubu Electric Power Co.,Inc.

## Expected 4S developing schedule





## 2. 4S applications

### 4S applications (1)

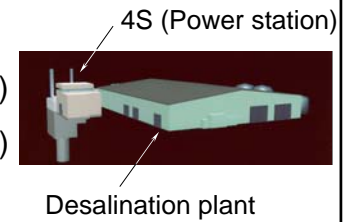
#### Sea water desalination

Single 4S Plant

- Two stage reverse osmosis system
- Water production:

34,000 m<sup>3</sup>/day (10MWe)

170,000 m<sup>3</sup>/day (50MWe)

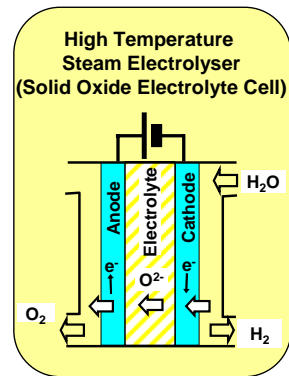


### 4S applications (2)

#### Hydrogen production

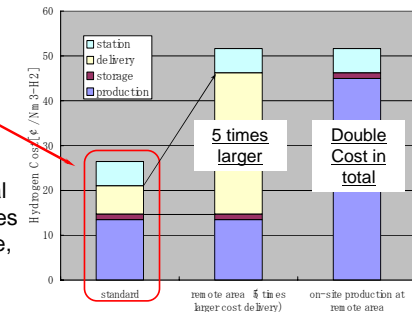
Single 4S Plant

- High temperature steam electrolyser,
  - No CO<sub>2</sub> emission.
  - Hydrogen production:
- 3,000 Nm<sup>3</sup>/h (10MWe)
- 15,000 Nm<sup>3</sup>/h (50MWe)



#### Discussion: **Acceptable cost of hydrogen in rural area.**

- \*Point 1: Transportation cost would increase along the distance from production site to user area.
- \*Point 2: Production cost in rural area tends to increase because of scaling-effect (requested production capacity is not so large).



- \*Assumption: If transportation cost for rural area would increase to 5 times larger than the standard case, double cost in total might be acceptable for rural area?

### Summary

**4S** is a sodium cooled, metallic fuelled small fast reactor with long core lifetime.

**4S** has a proper features for distributed energy station in rural areas, such as

- No refueling,
- Passive safety,
- Lower maintenance requirements,
- Transportability on construction,
- Reasonable cost.

## Pre-Publication Draft – Subject to Change

### APPENDIX B. Detailed Discussion of Hydropower, Solar, and Conservation

Presented below are detailed discussions of the Hydropower, Solar, and Conservation topics. These technologies are available to be applied in Galena, but their nature or capacity is not suited to make large impacts on operation of the electric utility. They can be used in conjunction with the utility (as add-on modules) or by end-users (utility customers) to reduce their energy use.

#### Hydro - In-river Turbines

Galena is on the north bank of the Yukon River, one of the largest in the country. A tremendous amount of water passes the site each day – winter and summer and seems to be a logical place to install in-river turbines for electric power generation. However, compared to the load requirements of the City, this may not be a valid conclusion. A variety of turbines are being developed. The one apparently most suited to the Galena site is under development by UEK Corporation. It is proposed to be installed in rivers, anchored to the bottom, and operated year around – even under ice. A project to demonstrate it at village Eagle on the upper Yukon River has been approved but is awaiting U.S. DOE funding. This turbine design has dual 3-meter diameter blades. To estimate the power output of a similar unit at Galena, a look at the power density is in order.

The power density in a flowing fluid is

$$P_{max} = 0.5\rho V^3$$

For water flowing at  $V = 2$  m/sec (characteristic of the Yukon at Galena) and density  $\rho = 1000$  kg/m<sup>3</sup> corresponding to 4 kW/m<sup>3</sup>. For reasons related to mass conservation and efficiency, one may only be able to capture 40% of this or less with a conventional turbine. For a water turbine with two 3-meter turbines or an area of 14.1 m<sup>2</sup>, this results in power generation of 22.5 kW – much less than that required by the City's load. Ten units would have to be installed to make even a marginal contribution and the cost would be too great for the benefit. UEK estimates \$ 1,000/kW capacity for a 10-MW plant yet to be built.

(<http://www.delawareonline.com/newsjournal/local/2003/09/06tidalpowerplant.html>)

On the other hand, an operational 300kW tidal turbine in Norway, costs \$23,000/kW capacity. (<http://www.eere.energy.gov/RE/ocean.html>)

Operational issues include turbine blade erosion [and maybe even destruction] caused by solid objects in the river, impacts on aquatic life, and hazards to navigation. For rivers that are ice-covered at least part of the year, one must also deal with potential damage to submersed structures associated with breakup.

On the plus side, the Yukon River flows year round so the hydro resource is a continuous one.

## Pre-Publication Draft – Subject to Change

### Water turbines

Several firms worldwide have developed in-stream water turbines with applications to typically capture the power from tidal currents. UEK Corporation has estimated the capital cost for 56 machines generating 10.8 MW in a 7-knot current to be \$10M. It is a buoyant turbine/generator suspended like a kite in a tidal stream (Tricon Consultants, 2002). At the present time, the standard UEK machine consists of twin turbines, each 3 m in diameter. This produces 90 kW in 5-knot currents and weighs approximately 3 tons without the anchorage harness and shore equipment. UEK plans to have a 6.7 m twin turbine system available in the future and has plans for a 1-MW system.

Blue Energy Canada is developing Darrieus [vertical axis] turbines and Marine Current Turbines Ltd [MCT] incorporates two axial flow rotors, each 15 to 20 m in diameter mounted on a vertical tower set in the seabed. Each turbine could develop up to 1 MW.

Limited cost data are available for the MCT units and for smaller UEK units. The lack of detailed cost data from other tidal current companies makes it impossible to compare the proposed technologies on the basis of cost efficiency. For two 15.9-m diameter variable-pitch rotors with a combined power output of 1 MW at a rated velocity of 2.3 m/s, estimated units costs of electricity at two different sites on the Canadian west coast were \$0.11 [800 MW cap] and \$ 0.26/kWh. [43 MW]

For these studies, the energy output was estimated assuming a rotor efficiency of 45% (based on wind power experience), gearbox and generator efficiencies of 94% and 92%, respectively, and a reliability of 95%. A discount rate of 8% was assumed with the scheme being decommissioned after 25 years of production.

A 300-kW unit [\$7M] in Norway operating in a 1.8 m/sec current has  $D = 20$  m blades. It can rotate to keep the turbine facing the current and is 12% efficient. This tidal power plant in Kvalsundet was made by Hammerfest Strø.

<http://www.eere.energy.gov/RE/ocean.html>

### Solar

#### Solar-electric

Vendors of PV components in Fairbanks include ABS Alaskan [907-452-2002] and Arctic Technical Services [907-452-8368]. Major US manufacturers include BP Solar [<http://www.bpsolar.com>], and Kyocera Solar Inc. [<http://www.kyocerasolar.com>].

In one specific example, the BP 3160B photovoltaic module has 72 cells in series and produces 160 watts [4.5 A at 35 V] of nominal maximum power [at 1 sun]. It has a footprint of 159 x 70 cm [1.11 m<sup>2</sup>]. It weighs 35 lbs and has a 25-yr power output warrantee. The temperature cycling range is – 40 to 185°F, and the allowable wind and snow loadings are 50 and 113 psi, respectively. The temperature coefficient [Tcoef] for power is – 0.5%/°C with a nominal panel  $T = 47^{\circ}\text{C}$  at  $T_a = 20^{\circ}\text{C}$ ,  $e_s = 0.8 \text{ kW/m}^2$ , and  $V_w = 1 \text{ m/sec}$ . The negative Tcoef is good news for Alaska. For example, if the panel  $T = 5^{\circ}\text{C}$  instead of a nominal  $25^{\circ}\text{C}$ , the output power will be 10% higher.

## Pre-Publication Draft – Subject to Change

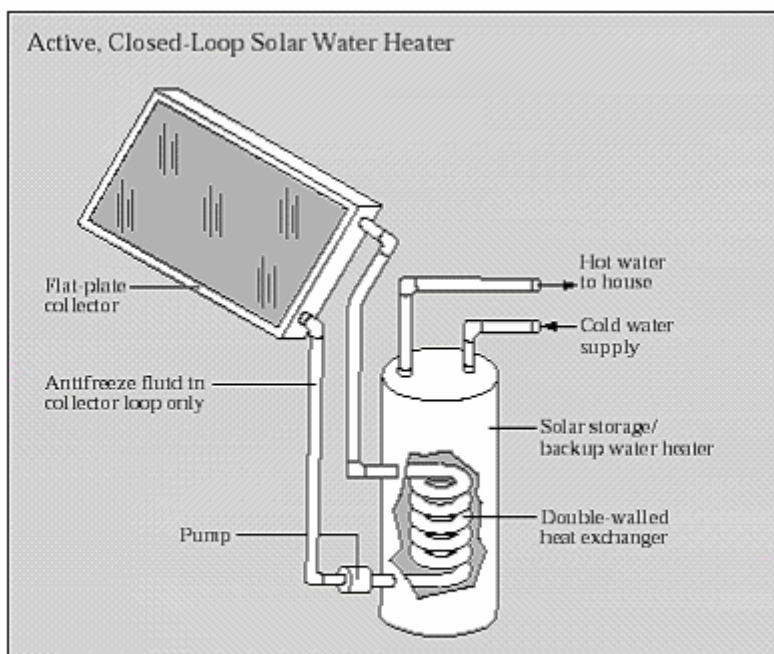
As an example, **Figure 2.8**, indicates average daily insolation in Fairbanks [approximating that for Galena] from March – July of about  $5 \text{ kWh/m}^2$  or about  $5.5 \text{ kWh}$  incident on the BP 3160B daily for a tilt angle of  $64^\circ$ . This panel produces  $160 \text{ W}$  for each  $1000 \text{ W/m}^2$  incident or  $160 \text{ Wh}$  for each  $\text{kWh/m}^2$  incident. Hence, its nominal daily output at  $25^\circ\text{C}$  is  $5[160] = 800 \text{ Wh}$ . This can be increased by ambient temperatures colder than  $25^\circ\text{C}$  and decreased by system losses. If the solar generated electricity is worth about  $\$0.28/\text{kWh}$ , then over the aforementioned 5-month period, the approximately  $150[0.8] = 120 \text{ kWh}$  would be worth about  $\$33$ . If one assumes an installed cost of  $\$10/W_p$ , then the initial capital outlay would be  $\$1,600$ . For the nine months [March through November], the insolation for a collector at latitude tilt of about  $1131 \text{ kWh/m}^2$ . This corresponds to a daily average of about  $4.2 \text{ kWh/m}^2$ . So, the PV module would output  $1131[0.16] = 180 \text{ kWh}$  worth approximately  $\$51$ , making a very long payback period.

### Solar Thermal

Solar thermal technologies use the heat in sunlight to produce hot water, heat for buildings, or electric power. Solar thermal applications range from simple residential hot water systems to multimegawatt electricity generating stations.

Throughout history, humans have used the heat from sunlight directly to cook food and heat water and homes. Today, solar collectors can gather solar thermal energy in almost any climate to provide a reliable, low-cost source of energy for many applications including hot water for homes, residential heating, and hot water for industries such as laundry and food processing. In recent years, utilities have begun to use solar thermal energy to generate electricity by boiling water and using the steam to drive a turbine which generates electrical power.

Millions of solar thermal systems are in place around the world today with many used for hot water heating. The three types of collectors are flat-plate, evacuated-tube, and concentrating. The most common, the flat-plate type, consists of an insulated, weatherproofed box containing a dark absorber plate at the bottom with the side closest to the sun covered with a transmitting material such as glass. The fluid being heated flows through tubes placed on the black surface and can be warmed by tens of degrees C as it passes through the collector. If the fluid is pure water, it must be drained if the temperature is predicted to fall below freezing. The water can be forced through the collector by a pump or can flow because of thermal siphon effects. The latter relies on the fact that warm water is less dense than cold and hence tends to rise. The active system shown in **Figure B.1** below relies on a double-walled heat exchanger to prevent the antifreeze solution on the hot side from contaminating the domestic water on the cold side. Not shown are sensors and controls to protect the system from excessive temperatures or pressures. This control loop would, for example, only turn the pump on to circulate water through the collector when the water temperature about to leave the collector exceeded a preset amount such as  $90^\circ\text{F}$ . It could cause a pressure relief valve to release fluid if the pressure exceeded a set point.



An active, closed-loop system heats a heat-transfer fluid (such as water or antifreeze) in the collector and uses a heat exchanger to transfer the heat to the household water.

**Figure B.1** An active solar closed-loop water heating system. Courtesy of U.S. DOE

<http://www.eren.doe.gov/erec/factsheets/solrwatr.pdf>

In addition to collectors, the complete system needs an insulated storage tank, and sensors and controls to prevent overheating. Cold water flows from the bottom of the insulated storage tank to the bottom of the collector, and then returns to the storage tank when warmed. Active systems use electric pumps, valves, and controllers to circulate water or other heat-transfer fluids through the collectors and range in price from about \$2,000 to \$4,000 installed for residences. Storage tank sizes can range from 50 gals for 1 to 3 people up to 120 gals for 4 to 6 people. For sizing collector area, allow about 40 ft<sup>2</sup> for 2 people with another 8 ft<sup>2</sup> for each additional person in the Sun Belt. These numbers should be around 60% larger for the northern United States.

<http://solstice.crest.org/renewables/re-kiosk/solar/solar-thermal/index.shtml>

<http://www.eren.doe.gov/erec/factsheets/solrwatr.pdf>

One example of a technology applicable for northern climates, Thermomax Evacuated Heat Pipe Solar Collectors, consists of copper heat pipes inside vacuum sealed tubes.

As the sun shines on the black surface of fins mounted on the heat pipes, the alcohol within the heat pipes is heated and the hot vapor created rises to the tops of the pipes. Water, or glycol, flows through a manifold at the top of the tube bank and picks up

## Pre-Publication Draft – Subject to Change

the heat from the tubes. The heated liquid circulates through another heat exchanger and gives off its heat to water stored in a solar storage tank.

A 20-tube array is 60" by 80" by 6 " and gives a maximum of ~ 25K Btu/day ~ 8 kWh/day

The A ~ 3 m<sup>2</sup> [not all of this area filled with tubes] and, with a peak insolation ~ 5.6 kWh/m<sup>2</sup>/day, we expect ~ 16.5 kWh in. Hence, the system efficiency  $\epsilon_p$  ~ 50 %.

<http://www.thermomax.com/>

### Energy Conservation

Energy conservation refers to a variety of strategies employed to reduce the demand for energy. This can include adding extra insulation on building exteriors, setting building thermostats closer to ambient temperatures, or carpooling. Conservation is different from increasing energy efficiency, which refers to increasing the useful output for a given energy input. This could involve replacing incandescent light bulbs with compact fluorescent ones, driving more fuel-efficient motor vehicles, and buying more efficient appliances.

Projections made in early 1970s indicated the United States would be using energy at the rate of 160 Q by 2000 (Ristinen and Kraushaar, 1999). In actuality, our use today is less than 100 Q. Here,  $Q = 10^{15}$  Btu where a Btu is the energy required to heat 1 lb of water by one degree Fahrenheit. A typical home in Alaska today might require 100 million Btu annually for space heating. Reasons that our energy use today is less than predicted include a rising cost of energy, the adoption of many federally and state sponsored energy conservation programs, and the use of more efficient technologies.

In Alaska, there is a large potential for fuel oil savings in villages by using heat captured from the jacket water of diesel-electric generators for space heating.

Ideas for lowering energy use in homes include lowering the water heater thermostat temperature to 120°F, insulating the water tank and hot water piping, replacing incandescent light bulbs with compact fluorescent ones, installing better weather stripping, increasing the thickness of insulation, and installing air to air heat exchangers. The latter preheat outside air by capturing heat from the inside air before it exits to the outdoors. Their use can save hundreds of dollars annually in fuel bills in a residence in Alaska. As much as 30 percent of a home's heating and cooling energy is lost through leaky ductwork. In the United States, that totals \$5 billion in wasted energy each year. A good site for energy conservation issues in homes including heat loss from ducts is

<http://www.southface.org/home/sfpubs/miscpubs.html>

A 15-watt compact fluorescent light bulb costing about \$5 and lasting 10,000 hours provides the same illumination as a 60-watt incandescent bulb costing about \$0.50 and lasting 1000 hours. Hence, over 10,000 hours of use, the total capital outlay for each is the same, \$5.00. But, the compact fluorescent will use  $[60-15][10] = 450$  kWh less electrical energy and save \$45 in energy bills at \$0.10/kWh. Replacing

## Pre-Publication Draft – Subject to Change

the higher use light bulbs in a home with compact fluorescent light bulbs can easily save hundreds of dollars in energy bills over a several year period.

As an example of a federal program encouraging energy conservation, the U.S. Department of Energy (DOE) has established a [Center Of Excellence For Sustainable Development](#). This center assists communities across the United States in establishing programs on community conservation, industrial efficiency, building efficiency, community renewable energy, and demand-side management (DSM).

The [Energy Efficiency And Renewable Energy Network of the U.S. Department of Energy](#) has a web site dedicated to helping homeowners save energy. The site covers topics such as weatherization, water heating, lighting, and appliances. It has a special section on the use of windows in cold climates, encouraging the use of double pane windows with low emissivity coatings. With appliances representing about 20% of a household's energy consumption, buying energy efficient refrigerators can save up to \$1000 over a 15-year lifetime compared with a model designed 15 years ago. In fact, the cumulative energy saved by adopting energy efficient refrigerators starting around 1974 represents \$17 billion annually in the United States. This energy savings represents the value of all electricity produced by nuclear power plants.

The American Council for an Energy Efficient Economy (Prindle, 2003) found a typical U.S. household could save \$500 annually by adopting more efficient appliances and lights.

According to MAFAc (2002), aggregate household electrical energy use could improve from roughly 6.7kWh/ft<sup>2</sup>/yr to around 4.5kWh/ft<sup>2</sup>/yr if rural households adopted a number of the end-use energy efficiency measures including switching from electrical hot water heaters to efficient oil-fired water heaters. Heating energy use could improve from roughly 1.14 to around 1.0 gal/ft<sup>2</sup>/yr if rural households switched to high efficiency direct vent heaters for space and water heating.

The benefits of new high efficiency lighting and electric water heater replacement programs appear to far outweigh the cost, including the potential for “free riders,” short-term declines in utility energy demand and efficiency and market uncertainty.

Rural Alaska schools consume roughly 49,200,000 kWh/yr electric energy and 5 M gal/yr of fuel oil. According to MAFAb (2002), these could each be reduced by 50% by end-use efficiency improvements. Some of this is being realized every year as schools periodically replace existing inefficient lighting, appliances, fixtures, and HVAC equipment with new, more efficient ones.



## Pre-Publication Draft – Subject to Change

### APPENDIX C. Summary of Nuclear Regulations

Chapter I of Title 10, "Energy," of the Code of Federal Regulations (CFR) guide licensing of nuclear power plants. .

Among the most important for permitting are the following Parts:

#### Chapter 1 Title 10, "Energy," of the Code of Federal Regulations (CFR)

**10 CFR Part 2.** Governs all proceedings, other than export and import licensing proceedings, under the Atomic Energy Act of 1954, as amended, and the Energy

Reorganization Act of 1974, for --

(a) Granting, suspending, revoking, amending, or taking other action with respect to any license, construction permit, or application to transfer a license;

(b) Issuing orders and demands for information to persons subject to the Commission's jurisdiction, including licensees and persons not licensed by the Commission;

(c) Imposing civil penalties under section 234 of the Act; and

(d) Public rulemaking.

**10 CFR Part 50.** Domestic Licensing of Production and Utilization Facilities: Provide for the licensing of production and utilization facilities pursuant to the Atomic Energy Act of 1954, as amended (68 Stat. 919), and Title II of the Energy Reorganization Act of 1974 (88 Stat. 1242). This part also gives notice to all persons who knowingly provide to any licensee, applicant, contractor, or subcontractor, components, equipment, materials, or other goods or services, that relate to a licensee's or applicant's activities subject to this part, that they may be individually subject to NRC enforcement action for violation of § 50.5.

**10 CFR Part 51.** Environmental Protection Regulations for Domestic Licensing and Related Functions: Contains environmental protection regulations applicable to NRC's domestic licensing and related regulatory functions. Subject to these limitations, the regulations in this part implement Section 102(2) of the National Environmental Policy Act of 1969, as amended.

**10 CFR Part 52.** Early Site Permits, Standard Design Certifications, and Combined Licenses for Nuclear Power Plants: This part governs the issuance of early site permits, standard design certifications, and combined licenses for nuclear power facilities licensed under Section 103 or 104b of the Atomic Energy Act of 1954, as amended (68 Stat. 919), and Title II of the Energy Reorganization Act of 1974 (88 Stat. 1242). This part also gives notice to all persons who knowingly provide to any holder of or applicant for an early site permit, standard design certification, or combined license, or to a contractor, subcontractor, or consultant of any of them, components, equipment,

## Pre-Publication Draft – Subject to Change

materials, or other goods or services, that relate to the activities of a holder of or applicant for an early site permit, standard design certification, or combined license, subject to this part, that they may be individually subject to NRC enforcement action for violation of § 52.9.

As used in this part,

(a) Combined license (COL) means a combined construction permit and operating license with conditions for a nuclear power facility issued pursuant to subpart C of this part. A COL authorizes construction and conditional operation of a nuclear power facility. An application for a COL may, but need not, reference a standard design certification issued under Subpart B of 10 CFR Part 52 or an ESP issued under Subpart A of 10 CFR Part 52, or both.

(b) Early site permit means an NRC approval for a site or sites for one or more nuclear power facilities. The NRC can issue an ESP for approval of one or more sites for one or more nuclear power facilities separate from the filing of an application for a construction permit or combined license in accordance with 10 CFR Part 52. An ESP is a partial construction permit and is, therefore, subject to all procedural requirements in 10 CFR Part 2 that are applicable to construction permits. Applications for ESPs will be reviewed according to the applicable standards set out in 10 CFR Parts 50 and 100 as they apply to applications for construction permits for nuclear power plants. Early site permits are good for 10 to 20 years and can be renewed for an additional 10 to 20 years. ESPs address site safety issues, environmental protection issues, and plans for coping with emergencies, independent of the review of a specific nuclear plant design.

(c) Standard design means a design which is sufficiently detailed and complete to support certification in accordance with subpart B of this part, and which is usable for a multiple number of units or at a multiple number of sites without reopening or repeating the review.

(d) Standard design certification, design certification, or certification means a Commission approval, issued pursuant to subpart B of this part, of a standard design for a nuclear power facility. A design so approved may be referred to as a certified standard design.

**10 CFR Part 100.** Reactor Site Criteria: The siting requirements contained in this part apply to applications for site approval for the purpose of constructing and operating stationary power and testing reactors pursuant to the provisions of part 50 or part 52 of this chapter.

### Reactor Decommissioning

NRC continues to regulate nuclear reactors after they are permanently shut down and begin decommissioning. Decommissioning is defined in NRC regulations as "to remove a facility or site safely from service and reduce residual radioactivity to a level that permits (1) release of the property for unrestricted use and termination of the license; or (2) release of the property under restricted conditions and termination of the license." The NRC maintains a series of internet web sites to provide information on

## Pre-Publication Draft – Subject to Change

reactor decommissioning (see <http://www.nrc.gov/reactors/decommissioning/regs-guides-comm.html>)

During the operating life of a reactor, plant components can become radioactive, either through contamination or as a result of activation caused by the fission reaction. Therefore, special care is needed in the decontamination and dismantlement of the facility. Contaminated materials are shipped to a low-level radioactive waste disposal site for burial. The NRC has adopted extensive regulations for dealing with the technical and financial issues associated with decommissioning.

During the reactor decommissioning process, NRC conducts inspections, processes license amendments (including approval of the License Termination Plan), and monitors the status of activities. This monitoring ensures that safety requirements are being met throughout the process.

All decommissioning associated with the 4S reactor is assumed will be the responsibility of Toshiba, the plant owner, or some other party, which will remove the entire reactor module at the end of the 30-year operating life. They will therefore be responsible for all wastes, spent fuel, etc. associated with the 4S plant. The NRC license will stipulate details as to how and when this removal will occur. NRC may also require some form of financial guarantee that the decommissioning occur according to the license granted. Because the entire reactor module will be removed, and will remain sealed until returned to the point of assembly, it is assumed that many of the standard NRC decommissioning requirements will not be applicable to the 4S reactor. However, once the power plant is removed, the demolition of the buildings and infrastructure are assumed to be the responsibility of Galena. This may include a requirement to monitor the remaining buildings and infrastructure for radioactivity prior to release for unrestricted use.

NRC regulations that are most applicable to reactor decommissioning include:

- 10 CFR Part 20, Standards for Protection Against Radiation
- 10 CFR Part 30, Rules of General Applicability to Domestic Licensing of Byproduct Material
- 10 CFR Part 40, Domestic Licensing of Source Material
- 10 CFR Part 50, Domestic Licensing of Production and Utilization Facilities
- 10 CFR Part 51, Environmental Protection Regulations for Domestic Licensing and Related Regulatory Functions
- 10 CFR Part 70, Domestic Licensing of Special Nuclear Material
- 10 CFR Part 72, Licensing Requirements for the Independent Storage of Spent Nuclear Fuel and High-Level Radioactive Waste
- 10 CFR Part 73, Physical Protection of Plants and Materials

Regulatory guides are issued in 10 divisions and are intended to aide licensees in implementing regulations. The guides most applicable to reactor decommissioning are in:

## Pre-Publication Draft – Subject to Change

Division 1, Power Reactors (<http://www.nrc.gov/reading-rm/doc-collections/reg-guides/power-reactors/active/>)

Division 4, Environmental and Siting (<http://www.nrc.gov/reading-rm/doc-collections/reg-guides/environmental-siting/active/>). The list of environmental and siting Reg Guides is provided below.

Division 8, Occupational Health (<http://www.nrc.gov/reading-rm/doc-collections/reg-guides/occupational-health/active/>)

**Monitoring and Emergency Preparedness:** NRC permits will likely involve some routine monitoring as well as some emergency preparedness activities. How involved each of these activities will be is not known at this time.




### NRC Regulatory Guides - Environmental and Siting (Division 4)

This page lists the title, date issued, revisions, and some ADAMS accession numbers for each regulatory guide in Division 4, Environmental and Siting.

**Table C.1.** NRC Regulatory Guides - Environmental Siting (Division 4)

Guide Number	Title	Rev.	Publish Date
4.1	Programs for Monitoring Radioactivity in the Environs of Nuclear Power Plants (Rev. 1, ML003739496)	--	01/1973
		1	04/1975
4.2	Preparation of Environmental Reports for Nuclear Power Stations (Rev. 2, ML003739519)	--	03/1973
		1	01/1975
		2	07/1976
4.2S1	Supplement 1 to Regulatory Guide 4.2, Preparation of Supplemental Environmental Reports for Applications To Renew Nuclear Power Plant Operating Licenses (ML003710495) (Proposed Supplement 1, DG-4002, published 8/91; second Proposed Supplement 1, DG-4005, published 7/98)		09/2000
4.3	(Withdrawn--See 41 FR 53870, 12/199/1976)	--	--
4.4	Reporting Procedure for Mathematical Models Selected To Predict Heated Effluent Dispersion in Natural Water Bodies (ML003739535)	--	05/1974
4.5	Measurements of Radionuclides in the Environment--Sampling and Analysis of Plutonium in Soil (ML003739541)	--	05/1974

## Pre-Publication Draft – Subject to Change

4.6	Measurements of Radionuclides in the Environment-- Strontium-89 and Strontium-90 Analyses (ML003739544)	--	05/1974
4.7	General Site Suitability Criteria for Nuclear Power Stations (Revision 2, ML003739894) (DG-4003, Proposed Revision 2, published 11/1992) (DG-4004, Second Proposed Revision 2, published 2/1995)	--	09/1974
		1	11/1975
		2	04/1998
4.8	Environmental Technical Specifications for Nuclear Power Plants (for Comment) (ML003739900)	--	12/1975
4.9	Preparation of Environmental Reports for Commercial Uranium Enrichment Facilities (Rev. 1, ML003739926)	--	12/1974
		1	10/1975
4.10	(Withdrawn--See 42 FR 59436, 11/17/1977)	--	--
4.11	Terrestrial Environmental Studies for Nuclear Power Stations (Rev. 1, ML003739935)	--	07/1976
		1	08/1977
4.12	(Not published)	--	--
4.13			
1	Performance, Testing, and Procedural Specifications for Thermoluminescence Dosimetry: Environmental Applications (Rev. 1, ML003739935)	--	11/1976
		07/1977	
4.14  (1.1M)	Radiological Effluent and Environmental Monitoring at Uranium Mills (Rev. 1, ML003739941)	--	06/1977
		1	04/1980
4.15 	Quality Assurance for Radiological Monitoring Programs (Normal Operations) -- Effluent Streams and the Environment (Rev. 1, ML003739945)	--	12/1977
		1	02/1979
4.16 	Monitoring and Reporting Radioactivity in Releases of Radioactive Materials in Liquid and Gaseous Effluents from Nuclear Fuel Processing and Fabrication Plants and Uranium Hexafluoride Production Plants (Rev. 1, ML003739950) (Draft CE 401-4, Proposed Revision 1, published 9/1984) (Errata published 8/1986)	--	03/1978
		1	12/1985
4.17		--	07/1982

## Pre-Publication Draft – Subject to Change

	Standard Format and Content of Site Characterization Plans for High-Level-Waste Geologic Repositories (Rev. 1, ML003739963) (Draft GS 027-4 published 4/1981) (Draft WM 404-4, Proposed Revision 1, published 2/1985)	1	03/1987
4.18	Standard Format and Content of Environmental Reports for Near-Surface Disposal of Radioactive Waste (ML003739515) (Draft WM 013-4 published 4/1982)	--	06/1983
4.19	Guidance for Selecting Sites for Near-Surface Disposal of Low-Level Radioactive Waste (ML003739520) (Draft WM 408-4 published 3/1987)	--	08/1988
4.20	Constraint on Releases of Airborne Radioactive Materials to the Environment for Licensees other than Power Reactors (ML003739525) (Draft DG-8016 published 12/1995)	--	12/1996

A number of other useful guidance documents are available, including:

- Responses to Frequently Asked Questions Concerning Decommissioning of Nuclear Power Reactors (NUREG-1628)
- Standard Review Plan for Evaluating Nuclear Power Reactor License Termination (NUREG-1700)
- Residual Radioactive Contamination From Decommissioning Parameter Analysis (NUREG/CR-5512)
- Standard Review Plan on Power Reactor Licensee Financial Qualifications and Decommissioning Funding Assurance (NUREG-1577)
- Technical Study of Spent Fuel Pool Accident Risk at Decommissioning Nuclear Power Plants (NUREG-1738)
- Multi-Agency Radiation Survey and Site Investigation Manual (MARSSIM) (NUREG-1575)
- NMSS Decommissioning Standard Review Plan (NUREG-1727)
- Report on Waste Burial Charges: Changes in Decommissioning Waste Disposal Costs at Low-Level Waste Burial Facilities (NUREG-1307)
- Decommissioning of Nuclear Power Reactors (Regulatory Guide 1.184)
- Standard Format and Content for Post-Shutdown Decommissioning Activities Report (Regulatory Guide 1.185)
- Fire Protection Program for Nuclear Power Plants During Decommissioning and Permanent Shutdown (Regulatory Guide 1.191)
- Final Generic Environmental Impact Statement on Decommissioning of Nuclear Facilities (NUREG-0586)

## **APPENDIX D. Economic Analysis Model**

This appendix provides sample output from the economic analysis model. The sample output illustrates some of the calculations and provides a sense of how the assumptions are translated into results. Some sections of the model, such as the daily dispatch algorithms, are too voluminous to present here. Others, such as the analysis of transmission lines, have already been presented in the text. Interested readers may obtain the full Microsoft Excel spreadsheet model from the authors.

The sample output is organized as follows:

- Parameters and Assumptions
- Diesel system cost
- Coal system cost
- Nuclear system costs

### **Table D.1. Parameters and Assumptions for Economic Analyses**

## Pre-Publication Draft – Subject to Change

### Parameters and Assumptions

	units	selected value (yr 1)	low value	high value
<b>Overall Parameters</b>				
Start Year		2010		
Real discount rate	%	4.0%		

### Loads and Common Parameters

#### Utility Electric Load

Initial load at busbar	MWh/yr	11,002		
Annual load growth	% per yr	2.0%		
Peak Load	MW	1.8		

	units	value		
<b>Residential Space Heat</b>				
number of houses, year 2010		220		
annual growth in number of houses		2.0%		
stove oil consumption per house	gallons/yr	1,000		
residential furnace efficiency		75%		
residential fuel price premium (delivery c	\$/gallon	0.75		
Utility line upgrades capital cost	\$	800,000		
customer premises upgrade cost	\$/house	3,000		
electric dist'n loss from busbar to house		10.0%		
<b>District Heat</b>				
Current district heat load	B Btu/yr	8.0		
Cost of bulk distribution pipe	\$/foot	200		
Air station boiler efficiency		80%		
Distance from power plant to air station	miles	2.0		
district heat loss in pipes		10.0%		
Heat load factor (based on HDD data)		0.51		
Heat sales tariff as % of net avoided cost		75%		



**Pre-Publication Draft – Subject to Change**

**Table D.1. Parameters and Assumptions for Economic Analyses - continued**

**Diesel**

	units	selected value (yr 1)	low value	high value
<b>Diesel capital cost</b> (replace engines)	\$/kW	400		
<b>Diesel Fuel</b>				
Utility fuel initial price	\$/gallon	2.15	1.50	2.15
Annual real escalation	% per yr	2.0%	0.0%	2.0%
Utility initial fuel efficiency kWh measured at busbar	kWh/gal	14		
Efficiency of New Units	kWh/gal	15		
<b>Nonfuel diesel O&amp;M</b>				
Diesel generation labor	\$/year	305,157		
Variable O&M (includes overhauls)	\$/kWh	0.017		

**Coal**

	units	selected value (yr 1)	low value	high value
<b>Coal plant capital cost</b>	\$/kW	3,000		
<b>Coal plant availability</b>		95%		
<b>Coal plant efficiency</b> (electric output/coal input)		40%	30%	40%
Coal or nuclear "heat to electric" efficiency		50%		
<b>Coal fuel</b>				
Energy content	M Btu/ton	20		
Delivered price of coal	\$/ton	100	100	125
Ash disposal cost	\$/ton	20		
<b>Nonfuel coal O&amp;M</b>				
Coal labor	people	6		
cost per operator	\$/yr	53,200		
variable O&M and consumables	\$/kWh	0.01		

**Nuclear**

	units	selected value (yr 1)	low value	high value
<b>Nuclear capacity</b>	MW	10.0		
<b>Nuclear capital cost</b>	\$	0		
Nuclear security staff	people	34	4	34
Nuclear operator staff	people	8		
Nuclear availability		95%		
Nuclear annual supplies and expenses	\$/yr	500,000		

**Pre-Publication Draft – Subject to Change**

**Table D.2. Diesel-Only Power Supply Economic Analysis**

<b>Diesel-Only Power Supply Economic Analysis</b>					
				Year	
				1	30
Variable		Units	Present Value	2010	2039
<b>Busbar Energy Requirements</b>		MW h		11,002	19,539
<b>Peak Demand</b>		MW		1.8	3.2
<b>Diesel Fuel Use by Unit</b>					
	kWh/gal				
1	15.0 New	gal		733,497	1,302,576
2	15.0 New	gal			
3	14.0	gal			
4	14.0	gal			
5	14.0	gal			
6	14.0	gal			
<b>Total Diesel Fuel Used</b>		gal		733,497	1,302,576
<b>Diesel Fuel Price</b>		\$/gal		2.15	3.82
<b>Total Diesel Fuel Cost</b>		\$	\$45,745,507	1,577,018	4,973,321
<b>Labor</b>			\$5,276,785	305,157	305,157
<b>Other Diesel System Variable Costs</b>					
Major Overhauls ** included in O&M					
O&M (includes overhauls)		\$	\$4,129,163	187,042	332,157
<b>Total nonfuel variable cost</b>		\$	\$4,129,163	187,042	332,157
<b>Diesel Avoidable Capacity Cost</b>		\$	\$4,147,366	711,886	
amortized				239,843	239,843
<b>Total Cost of Busbar Diesel Electricity</b>		\$	<b>\$59,298,821</b>	<b>2,309,059</b>	<b>5,850,478</b>
<b>Rate Impacts</b>				2010	2039
Total sales		MW h		9,902	17,585
avoidable busbar cost		\$/kW h		0.23	0.33
distribution, general, and admin		\$/kW h		0.07	0.06
<b>Average cost of electric service</b>		<b>\$/kW h</b>		<b>0.30</b>	<b>0.39</b>

Pre-Publication Draft – Subject to Change

Table D.3. Coal Power Supply Economic Analysis

<b>Coal</b>						
<b>Power Supply Economic Analysis</b>						
				Year		
				1	30	
Variable		Units	in- clude?	Present Value	2010	2039
<b>Busbar Energy Requirements</b>						
Utility electricity		MW h	1		11,002	19,539
Existing city heating loop		MW h	1		2,344	2,344
Residential heating		MW h	0		-	-
Air station heating		MW h-equiv	1		8,464	8,464
Greenhouse		MW h	0		-	-
<b>Total Energy Requirements at power plant</b>		MW h			21,811	30,347
<b>Total Energy Output Capacity (electric equ</b>		MW			4.0	4.0
<b>Availability</b>		%			95%	95%
<b>Energy from Coal and from diesel</b>						
firm energy from coal		MW h			12,679	20,788
firm energy from diesel		MW h			667	1,094
non-firm energy for Air Station		MW h-equivalent			8,040	5,816
<b>Total Energy generated by coal</b>		MW h-equivalent			20,719	26,605
<b>Coal Fuel</b>						
Coal requirements		tons			8,839	11,350
Cost per ton		\$/ton			100	100
<b>Total coal fuel cost</b>		\$		17,035,458	883,920	1,135,027
<b>Coal Capital</b>				12,000,000	693,961	693,961
<b>Coal labor</b>				5,519,617	319,200	319,200
<b>Diesel peaking and backup variable cost (from below)</b>				2,614,234	96,746	267,259
<b>Other coal system variable costs</b>						
consumables and variable O&M				3,993,075	207,189	266,048
Ash disposal @ \$20/ton				3,407,092	176,784	227,005
<b>Total nonfuel variable cost</b>				7,400,167	383,973	493,053
<b>Total busbar cost of coal system</b>				40,576,400	2,170,610	2,642,453
less: net value of heat sent to air station				(17,483,703)	(839,746)	(1,113,613)
<b>equals: net busbar cost of coal system</b>				<b>23,092,697</b>	<b>3,010,357</b>	<b>3,756,066</b>

## Pre-Publication Draft – Subject to Change

### Table D.3. Coal Power Supply Economic Analysis – continued

<b>Avoided cost from heat used by Air Station</b>				
Air station end-use heat demand	B Btu		52.0	52.0
Coal heat energy delivered to station	B Btu		49.4	35.7
avoided diesel fuel	gallons		447,388	323,659
avoided diesel price	\$/gallon		2.15	3.82
avoided diesel cost	\$	19,595,703	961,884	1,235,750
less: capital cost of pipe upgrade		(2,112,000)	(122,137)	(122,137)
equals: Net value (fuel savings only) of heat		17,483,703	839,746	1,113,613
Net value per M Btu delivered at plant	\$/M Btu		15.30	28.05
<b>Rate Impacts</b>				
			2010	2039
Total cost of coal system			2,170,610	2,642,453
prospective tariff for heat (metered at plant)	\$/M Btu		11.48	21.04
amount of heat sold (metered at plant)	B Btu		54.9	39.7
sales revenue from base heat sales	\$	13,112,777	629,810	835,210
net cost of generation			1,540,801	1,807,243
distribution, general, and admin			710,728	1,054,748
Utility revenue requirement from rates			2,251,529	2,861,991
utility non-heat electricity sales	MWh		9,902	17,585
Electric heat sales to homes	MWh		0	0
<b>Average cost of electric service</b>	<b>\$/kWh</b>		<b>0.23</b>	<b>0.16</b>
avoidable busbar cost	\$/kWh		0.16	0.10
distribution, general, and admin	\$/kWh		0.07	0.06

Pre-Publication Draft – Subject to Change

Table D.4. Nuclear Power Supply Economic Analysis

<b>Nuclear</b>					
<b>Power Supply Economic Analysis</b>					
				Year	
				1	30
			Present		
	Variable	Units	Value	2010	2039
<b>Busbar energy requirements</b>		MW h		11,002	19,539
<b>Peak demand</b>		MW		1.8	3.2
<b>Power output</b>		MW		10.0	10.0
<b>Availability</b>		%		95%	95%
<b>Available energy output</b>		MW h		83,220	83,220
	Firm energy requirements	MW h		21,330	35,617
	Firm energy supplied	MW h		20,263	33,836
	to utility electricity	MW h		10,452	18,562
	to district heat	MW h		2,227	2,227
	to home space heating	MW h		7,042	12,506
	to greenhouse	MW h		542	542
	Surplus energy available for H2 production	MW h		62,957	49,384
<b>Diesel energy to cover unavailability</b>		MW h		1,066	1,781
<b>Nuclear capital paid by utility</b>			0	0	0
	Nuclear decommissioning		[not considered in this model]		
<b>Labor</b>					
	plant operators	persons		8	8
	cost per operator	\$/yr		82,460	82,460
	Operator Labor			659,680	659,680
	security staff	persons		34	34
	cost per security staff	\$/yr		53,200	53,200
	Security Labor			1,808,800	1,808,800
<b>Total nuclear labor</b>			42,685,038	2,468,480	2,468,480
<b>Nuclear annual O&amp;M</b>			8,646,017	500,000	500,000
<b>Diesel backup variable cost (from below)</b>			4,984,179	181,911	515,947
<b>Total busbar cost of nuclear energy production</b>			56,315,234	3,150,391	3,484,427
<b>less:</b>	Avoided cost from using residential electric heat (below)		(15,903,166)	(553,568)	(1,700,247)
<b>less:</b>	Avoided cost of heat for air base, at power plant		(20,243,434)	(890,513)	(1,676,172)
<b>equals: Net busbar cost of electric service</b>			20,168,634	1,706,310	108,008
	Surplus energy for hydrogen production	MW h		62,957	49,384

Pre-Publication Draft – Subject to Change

Table D.4. Nuclear Power Supply Economic Analysis – continued

<b>Savings from sales of heat to air base</b>					
	Air station end-use heat demand	B Btu		52.0	52.0
	less: unserved energy at peak times	B Btu		0.0	0.0
	equals: heat energy delivered to base	B Btu		52.0	52.0
	avoided diesel fuel	gallons		471,000	471,000
	avoided diesel price	\$/gallon		2.15	3.82
	avoided diesel cost	\$	22,355,434	1,012,650	1,798,309
/less:	capital cost of pipe upgrade	\$	(2,112,000)	(122,137)	(122,137)
	Net value (fuel savings only) of heat at power plant		20,243,434	890,513	1,676,172
	Net value per M Btu of heat at power plant			15.41	29.01
<b>Rate Impacts</b>					
	Total cost of nuclear system		56,315,234	3,150,391	3,484,427
	prospective tariff for heat (metered at plant)	\$/M Btu		11.56	21.76
	amount of heat sold (metered at plant)	B Btu		57.8	57.8
	sales revenue from air station heat sales	\$	15,182,576	667,885	1,257,129
	net cost of generation		41,132,659	2,482,507	2,227,298
	distribution, general, and admin		14,299,453	710,395	1,037,214
	Utility revenue requirement from rates		55,432,111	3,192,901	3,264,511
	non-heat electricity sales	MW h		9,895	17,193
	Electric heat sales to homes	MW h		6,338	11,255
	<b>Average cost of electric service</b>	<b>\$/kW h</b>		<b>0.20</b>	<b>0.11</b>
	Check savings to homes:				
	per household cost of diesel			2,900	4,568
	per household cost of electric heat			5,667	3,306
<b>Required Diesel generation</b>					
		MW h		1,066	1,781
<b>Diesel Fuel Use by Unit</b>					
	kW h/gal				
1	14.0 Unit 1	gal		76,177	127,204
2	14.0 Unit 2	gal			
3	14.0 Unit 3	gal			
4	14.0 Unit 4	gal			
5	14.0 Unit 5	gal			
6	14.0 Unit 6	gal			
	<b>Total Diesel Fuel Used</b>	gal		76,177	127,204
	<b>Diesel Fuel Price</b>	\$/gal		2.15	3.82
	<b>Total Diesel Fuel Cost</b>	\$	\$4,595,785	163,781	485,672
<b>Other Diesel System Variable Costs</b>					
	Major Overhauls				
	Other Energy-related O&M	\$	\$388,394	18,130	30,274
	<b>Total Nonfuel Variable Cost</b>	\$	\$388,394	18,130	30,274
	<b>Diesel Avoidable Capacity Cost</b>	\$	\$0		
	<b>Total Identifiable Cost of [backup] Diesel</b>	\$	<b>4,984,179</b>	<b>181,911</b>	<b>515,947</b>