

*Cover Patent by the authors*

- 1) sturdy corder post; 2) horizontal bearing and/or support frames;
- 3) perforated plate; 4) element with angular section; 5) bar;
- 6) fastening elements; 7) clamping elements; 8) vertical wooden beads;
- 9) horizontal boards of wood.

# Resilient connections

**Adriana Rossi, Sara Gonizzi Barsanti\***

Department of Engineering, Università degli Studi della Campania, Luigi Vanvitelli.  
Email: \*sara.gonizzibarsanti@unicampania.it

**Abstract:** The paper presents Axis Structure, patented by the authors, awarded with Valere funds (VANvitelli pER la ricERca 2020) for the establishment of an innovative start-up, now academic spin-off. It is based on the assembly of iron and wood with 'pins' (in Latin 'axis') threaded to ensure an economic profit in line with the Sustainable Development Goals, reviewing ancient technologies in the light of advanced research. The focus is on the structural connections of a construction system that clamps the steel frame elements with the wooden infill, allowing assembling modular, prefabricated and flexible components customized on the design phase's request. It provides effective emergency shelters assembled or dismantled as quickly as tents but more stable, healthier and comfortable. With a single star key, the steel uprights can be attested with wooden and similar tampons avoiding nails and screws, which allows the total reuse of the components. The patented connections implement a new construction method promoting the self-construction of garden houses, leisure environments, bungalows, garages and quality housing modules, since they are resilient, resistant and with a controllable impact on the environment. The case study provides an opportunity to verify actions aimed at the implementation of Design for Adaptability strategies promoting virtuous life cycles that involves the entire community in sustainable models from an economic, environmental and social point of view.

**Keywords:** construction system, intuitive, eco-sustainable, adaptive, anti-seismic, rebuilt.

## 1. Introduction

Concepts such as ‘resilience’ and ‘sustainability’ have imposed a renewed perspective with which to frame the architectural or engineering project. A good construction practice has always carefully considered the choice of resistant and long-lasting materials and, not least, their biodegradability, necessary to minimize the problem of waste disposal (Lemer, 1996). However, sustainability is not limited to the reduction of non-renewable zero-impact resources, but extends to the versatility of the designed object (Mallach, 2006).

Promoting technologies that allow the replacement of components, their restoration or reuse, the adaptability of volumes<sup>1</sup> rather than their demolition to the changing needs of use (or wear), prevents obsolescence and reduces the waste of resources (Rockow, 2020). A planned reuse of elements, parts and materials, produces radical changes in the choice of systems and processes that make the artifacts, as a whole or in some of their parts, de-constructible, restorable or replaceable.

The so-called Design for Adaptability (DfA) takes the opportunity to rethink the architectural project. In accordance with the Industry 4.0 strategies and in relation to the Sustainable Development Goals (SDGs) set in the UN Agenda 2030<sup>2</sup>, an integrated approach encourages the development of a global method that involves all citizens.

The case study presented here is part of the actions that face an important paradigm shift, orienting towards sustainability. The flexible system of resilient connections offers a valid alternative to the construction and self-construction of robust, healthy and comfortable volumes, which can be dismantled and reassembled like tents, but, compared to these, more stable, healthy and secure, to perform the same or alternative functions (Adjodha, 2018).

Increasingly stringent standards in terms of energy efficiency of buildings are pushing the wood industry towards natural success. The parallel progress in the construction techniques sector has helped to generate a climate of confidence that government incentives have translated into terms of growth in demand. Both individuals and companies are interested in bio-compatible constructions that do not impact the territory with the violence of concrete. Compared to so-called ‘immovable’ assets, wooden buildings coexist with the nature of the surrounding landscape from which they derive their main material. The profits generated are a prelude to a competitiveness between manufacturers and entrepreneurs engaged in the sector. Given the question in these terms, the Clamp joints are a valid alternative to the technology

in use. Offering an innovative solution to connect wooden walls, the new product meets the needs of mini, single or multi-room buildings, to be used for all sorts of uses as well as very first emergency residences. The prefabrication of this technological system for frame systems highlights the flexibility of solutions and division of the internal spaces. In relation to geometric-dimensional constraints, the construction process shows the system’s aptitude to conform in a reversible and alterative sense. It is also adaptable given its ability to adequately relate to the needs of other subsystems by means of new external correlations. The system aims at providing ‘emotional’ as well as effective emergency shelters, capable of being assembled or dismantled in an easy and quick way also by a person who is not expert. The system is intended to build all different types of housing systems, office points, shops and more generally the appurtenances (private and industrial) as they fall within the so-called free building (DPR n.380/2001). Their demand amounts to tens of thousands, an estimate by no means exaggerated considering the number of companies that prefabricate and sell ‘garden houses’ and wooden structures for villas and condominiums.

## 2. Analysis of the problem

The construction of wooden houses is linked to ancestral models originally made with the overlapping of tree trunks. Their assembly was aimed at forming walls with a load-bearing function. The quality of the system was entrusted to their significant mass, which guaranteed thermal inertia and robustness. The use of gradually lighter materials (up to today’s use of slats, beads, plywood and similar construction elements) have made those executive technologies unstable and not very durable over time. On a functional level, the heavy walls limited the main drawback: wood is an organic material that shrinks and expands while deforming. The tolerances of the joints, which is the cause of the increasing instability over time, are certainly not eliminated with the use of multilayer slats.

Several technological changes have been introduced, and sometimes patented, to compensate for the tolerances generated by renouncing the construction of heavy walls that limited the shrinkage and expansion of the wood. In the patented Blockbau system (DE2608373) the joint is obtained by orthogonally fitting the ends of the elements as shown by other optimized solutions<sup>3</sup> (Fig. 1).

The industrialized process has lowered the costs of manufacturing, reducing processing times and the use of skilled work force. However, the waste of material due to wood scraps remains. An unsolved waste even during

U.S. Patent Sep. 2, 1980 Sheet 1 of 5 4,219,977

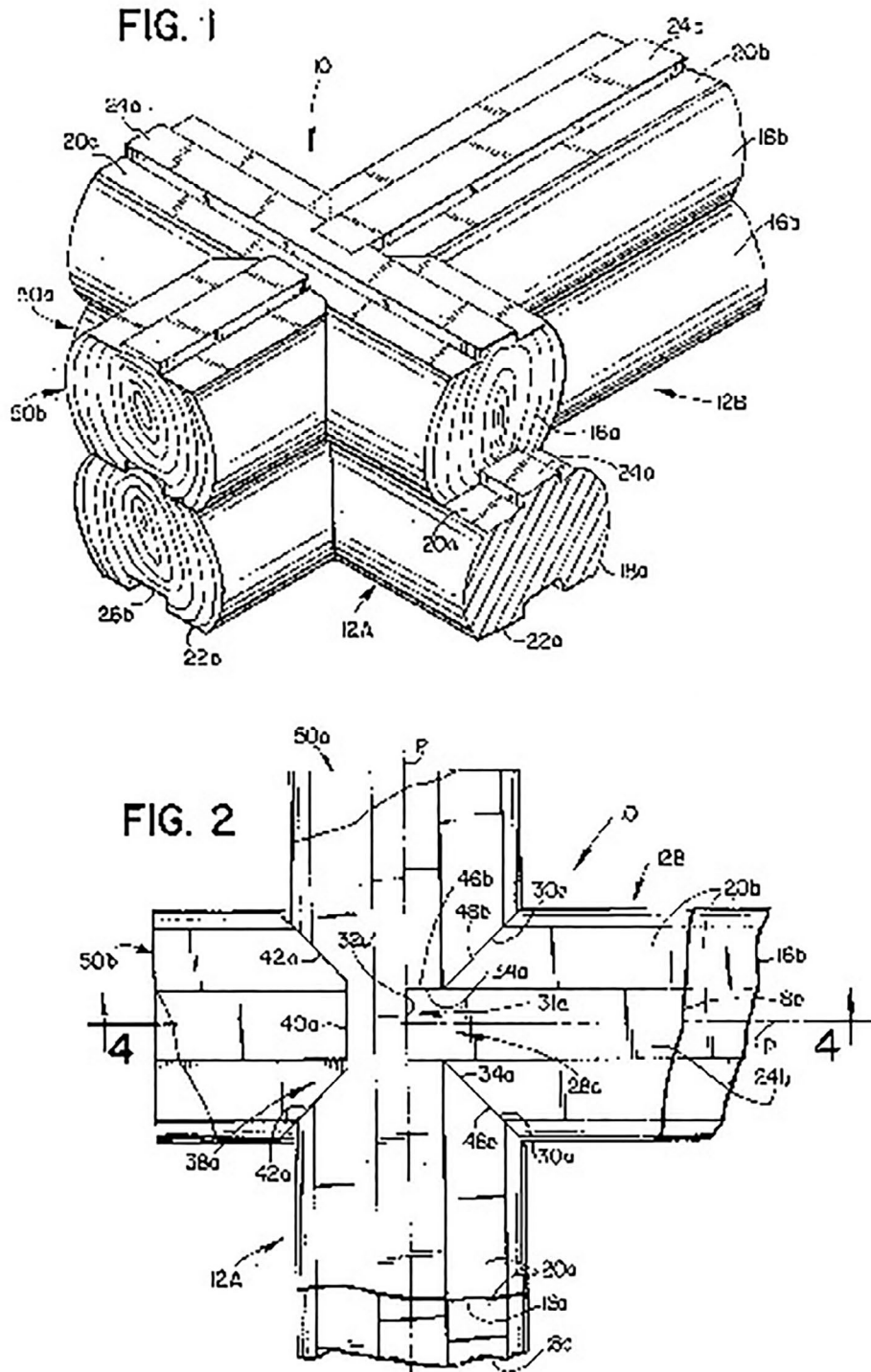

Figure 1 | Schema of the orthogonal interlocking joint extracted from Patent Log building construction”(US4219977A-01).

Patent Application Publication Mar. 17, 2005 Sheet 2 of 5 US 2005/0055966 A1

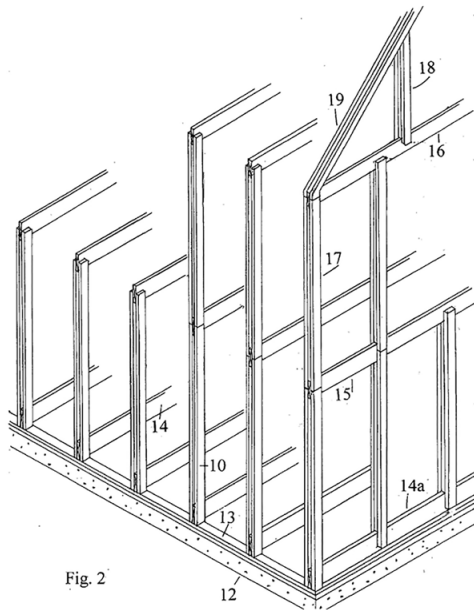

Fig. 2

Figure 2 | The schema of the “Integrated framing system” (US20050055966A1).

U.S. Patent Sep. 16, 1997 Sheet 1 of 3 5,666,781

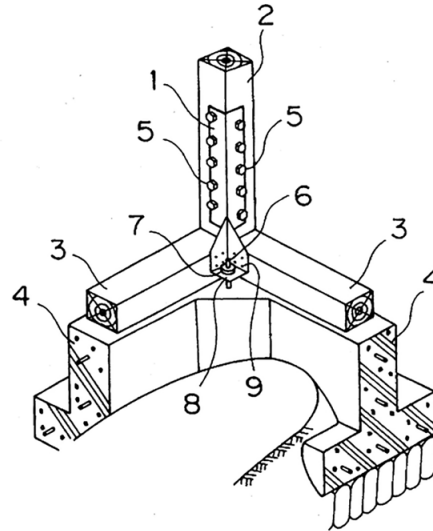

Figure 3 | The schema of the Metal Fasteners for wood construction use and a method of constructing a house” (US5666781(2)-2).

the twentieth century when the tolerances of the joints and frame structures have been improved (light frames). Castles of thin beams and strips arranged in modular sequences (Balllon Frame), have been used by tens of thousands of companies: the vertical uprights, however, require bracing grafted to the edges fixed with screws and nails. Among the “trellis” systems there are several licenses granted<sup>4</sup> (Fig. 2).

The Platform-Frame system allows to raise apartment buildings up to four floors. In these systems, the vertical continuity is broken by the floors which are transformed into platforms: in addition to the difficulty of organizing a site of medium-large complexity like this and which requires the use of skilled manpower, the problems reported in (Miller, 1996: 84) such as the deterioration of wood accelerated by screwed foreign bodies and the waste of workpiece (Turan, 2009: 175) remains. Both disadvantages do not seem resolved when metal frames are replaced, assembled and welded to the wooden structure<sup>5</sup> (Fig. 3).

In the intensive distribution of leisure or temporary building volumes not subject to the request for onerous concessions, the jointing of the edges is entrusted to spiked strips; in the most valuable cases, is delegated to the joints of multilayer or similar staves.

### 3. The Culture of the vice joint

There are many joining devices used to assemble wooden structures. All, however, involve the use of nails and screws. An alternative system to the fixed connections on the market is offered by the use of the patented vice joint<sup>6</sup>. This excludes all sorts of foreign bodies that break the wood and accelerate its degradation. The assembly device is original and innovative according to the granted patent category (“industrial invention”) and also quick and easy to assemble and disassemble. Its essential simplicity allows to construct modular, prefabricated and flexible customized components and these characteristics are its originality. By loosening the tight nuts from the inside, sheltered from the direct sun, rain or snow, a single person, without any experience, will be capable of building and deconstructing mono-plural rooms. The characteristics of the vertical assemblies create guide housings in which to slide, one by one, the slats - beads (and possibly also the panels).

The structure behaves like tracks within which the slats slide one over the other. This system also allows them not to fall during construction: by tightening the clamp joint, the slats become rigid; by loosening it, they can be removed one at a time since the vertical bar holds them in position. The removed slats remain intact since the housing is equipped with a clamp joint that does



Figure 4 | The system with the vertical assembly and the mounted slats.

not damage them, as well as all the elements of the *tompagno*. In this way, all the elements can be stacked to be easily transported with modest-sized multimodal vehicles and then stored, with stackable joints, in a small space in warehouses. The use of a clap joint and the resulting conservation of the shape of all the construction parts used for the structure assembled, permits to reuse everything different times with different purposes. With the use of a single star wrench and with the same speed used to position camping tents, it will be possible to reassemble wooden houses, leisure locations, and other different kind of quality constructions modules with steel frame. These effective as well as actual emergency shelters allow the evacuees to wait without further trauma for the availability of properly so-called prefabricated homes. (Fig. 4).

In the event of natural disasters or disasters attributable to human wickedness, the system manufactured guarantees the evacuees a valid alternative to the tent cities and caravans of the highest urgency. Compared to these, it guarantees a less precarious residence and furthermore the total reuse of the components involves, in the long term, a considerably lower cost for the communities. If not urbanized, the houses can be made autonomous by replacing the pitches of insulated tiles with

photovoltaic panels, providing them with a water purifier and a chemical toilet, and eventually a gas cylinder. The longevity of materials and components guarantees a zero impact on the environment.

The versatile and flexible system fits perfectly into the growing self-building demand. The “do it yourself” kit, complete with instruction, will allow the construction of the steel frame with a single star wrench, which the customer will complete by choosing from the multitude of wooden products of varying thickness and consistency on the market: the choice will have a significant impact on the final price.

The patented connections implement a new construction method capable of promoting the self-construction of garden houses, workshops, leisure environments, bungalows, kiosks, cabins, garages, newsstands and housing modules of resilient and resistant quality with controllable impact on the environment (Fig. 5 - 7).

The structural system with vice corner joint for wooden houses is composed of: a sturdy corner post (1) with diagonally pre-welded threaded pins in the internal corner. At the two ends of the angular section bar, two first perforated plates with relative holes are pre-welded,

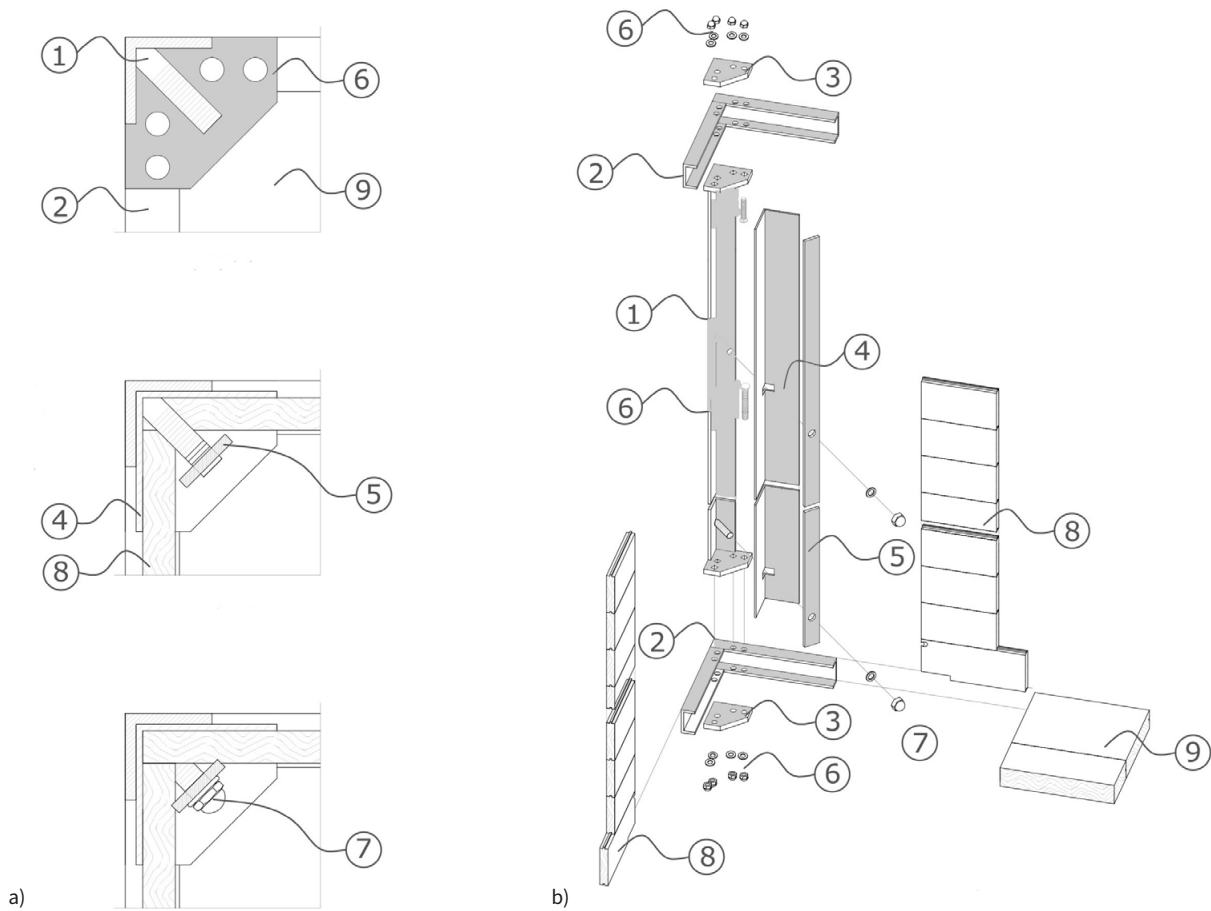

**Figure 5 |** . Structural system with corner clamp joint for wooden houses (extracted from patent: Adriana Rossi 0001429838 | class E04B1 34). In detail: 1) sturdy corner post; 2) horizontal bearing and/or support frames; 3) perforated plate; 4) element with angular section; 5) bar; 6) fastening elements; 7) clamping elements; 8) vertical wooden beads; 9) horizontal boards of wood.

necessary to fix the horizontal bearing and/or support frames (2), with the upright itself (1). The corner post (1) consists of a bar with an angular section obtained by cutting and bending a steel or other metal laminate suitably treated and of suitable thickness, capable of both supporting the vertical weight and acting as a housing for the vertical beads.

The load-bearing and horizontal support frames (2) are obtained by cutting and bending a sheet of steel or other metals suitably treated and of suitable thickness, with a profile comparable to a “U” in which the wings are proportionally longer than the stem and have the function of horizontal support of the entire structure. The load-bearing and/or horizontal support frames (2) are arranged at an angle and locked together thanks to the fastening of the corner post (1) with the second perforated

plate (3) through the fastening elements (6) whose pins are round head with square under head, to facilitate assembly. The nuts are blind to prevent the pins from oxidizing or damaging. The horizontal boards of wood (9) will be inserted in the lower horizontal supporting and support frames, and equipped with lateral coupling, such as to make them integral with each other, avoiding sensitive oscillations.

The second perforated plate (3) of the same shape as the first perforated plate (1) is positioned under the frames (2) locking them together at an angle to the corner post (1).

The element with angular section (4) is obtained by cutting and bending a steel sheet or other suitably treated metals. This element (4) is positioned inside the corner

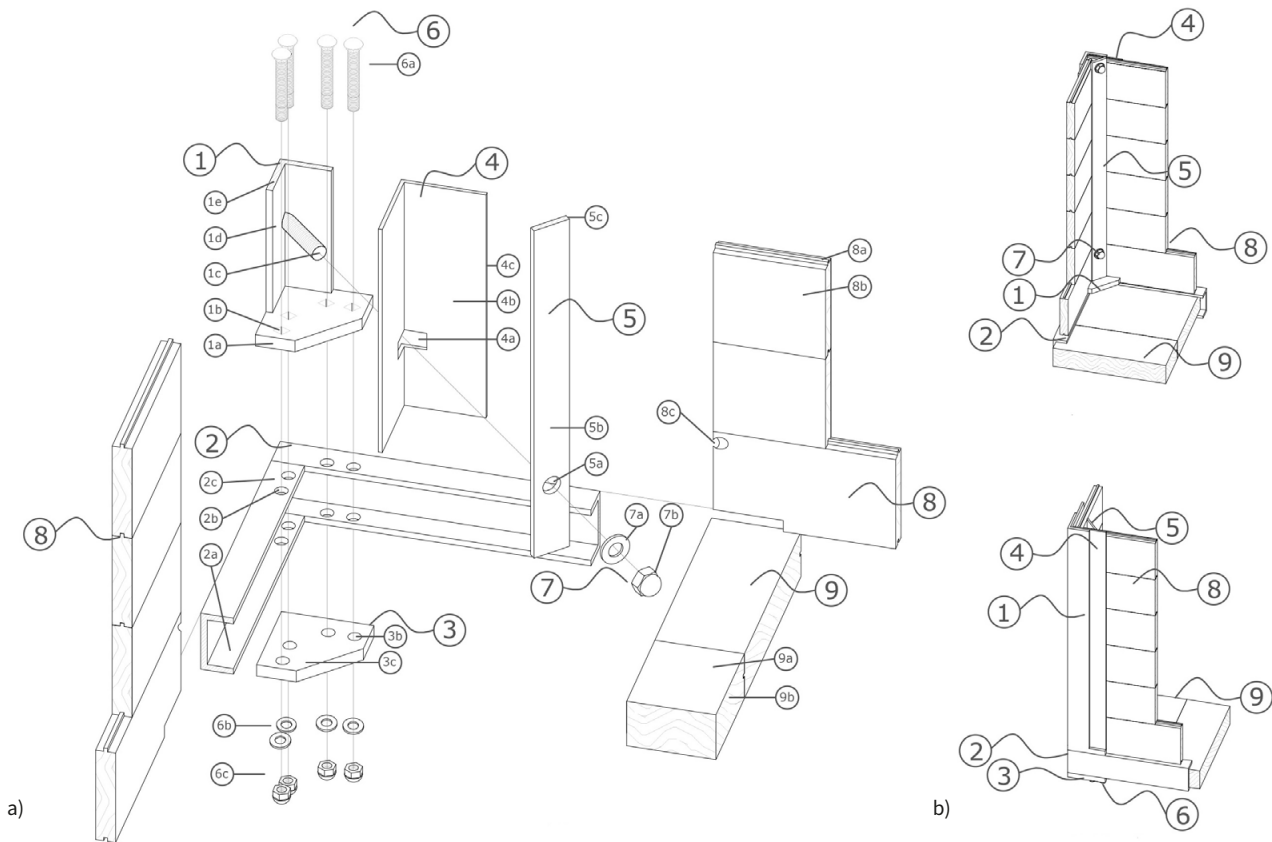

**Figure 6 |** . Structural system with corner clamp joint for wooden houses (extracted from patent: Adriana Rossi 0001429838 | class E04B1 34). In detail: 1) sturdy corner post; 2) horizontal bearing and/or support frames; 3) perforated plate; 4) element with angular section; 5) bar; 6) fastening elements; 7) clamping elements; 8) vertical wooden beads; 9) horizontal boards of wood.

post (1) through the alignment between the lead hole and the threaded pin.

The locking of the vertical wooden beads (8) with the corner post (1) takes place by tightening a bar (5) made of steel or other suitably treated metals, which has holes that have the function of invitation for the threaded pin of the corner post (1). Through a clamping action, the bar (5) advances penetrating inside the face of the beads and is blocked by the closure of the clamping elements (7) on the threaded pin.

The first horizontal table (9) is placed inside the hollow of the frame (2) and everything is locked with the fastening elements (6). Fig. 7 shows the completion of the structure by placing the upper frame (2) and the second perforated plate (3) above the frame and blocking everything with the fixing elements (6). In this way the structure becomes not only perfectly orthogonal, but also rigid, a rigidity that reaches its maximum when all the edges are tightened by the strips.

Each volume-module is made up of four vertical uprights, standardized metal elements, cut to the useful height of the room (2.60 m standard or other custom sizes). The vertical uprights pre-drilled and worked to be suitably connected to two horizontal frames with the aid of plates and bolted counter plates take on the appearance and function of a high-strength pillar. Overall, the rigid and non-deformable steel frame without bracing constitutes a solid cage: the lower horizontal frame houses the floor interlocking; the upper one the prefabricated roof truss.

With the aid of a vertical clamping bar, the bolts abutting the threaded pins are tightened in a vice. The assembly device is extremely simple and intuitive and, considering the longevity of the components and their total reuse, the cost will be convenient and competitive not only for individual citizens but for the community. Each element can be easily restored or replaced since the construction technique avoids screws and nails, that change the shape, the structure and the resistance of the wooden elements.



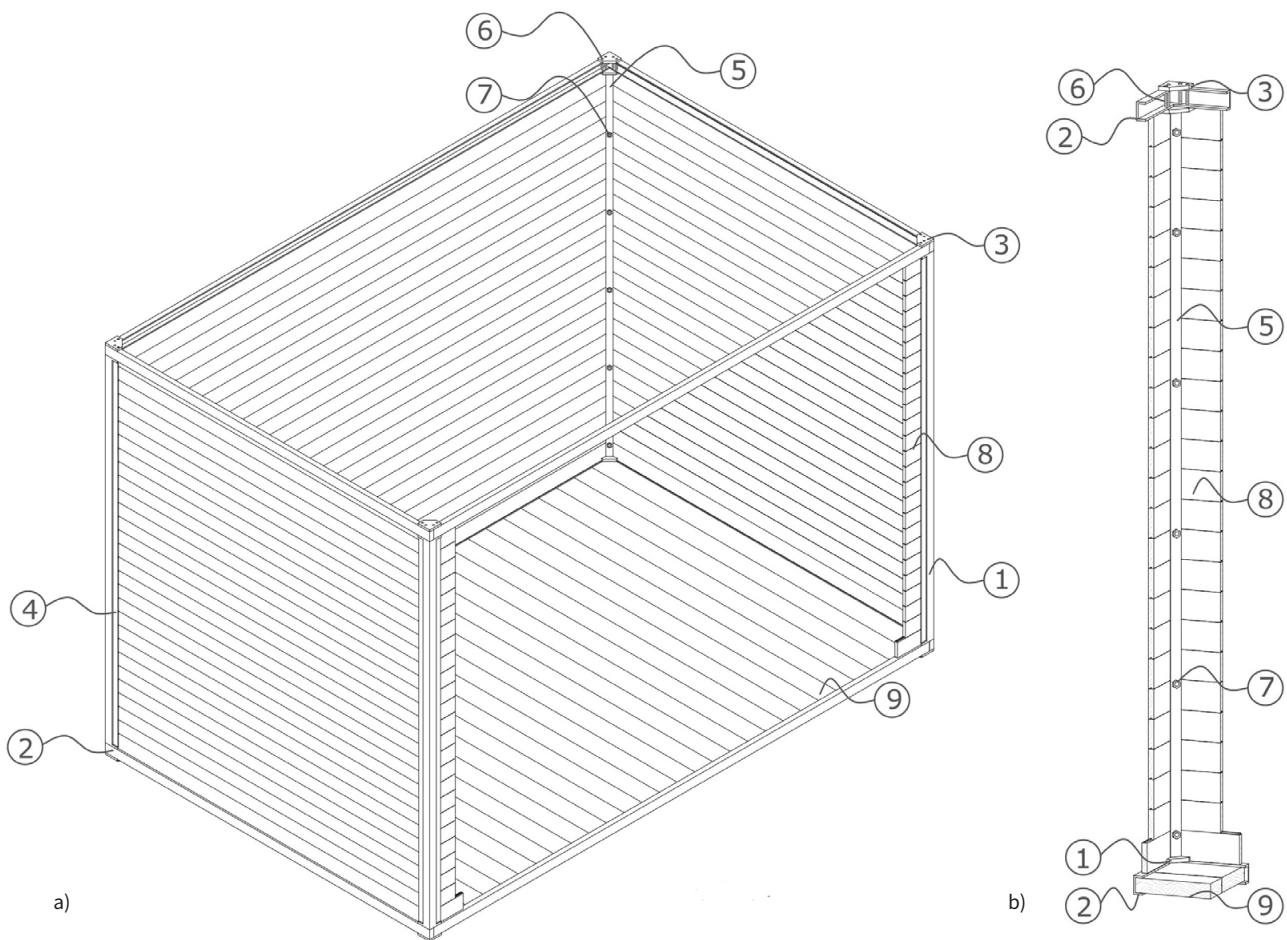

**Figure 7 |** . Structural system with corner clamp joint for wooden houses (extracted from patent: Adriana Rossi 0001429838 | class E04B1 34). In detail: 1) sturdy corner post; 2) horizontal bearing and/or support frames; 3) perforated plate; 4) element with angular section; 5) bar; 6) fastening elements; 7) clamping elements; 8) vertical wooden beads; 9) horizontal boards of wood.

In the latter case, waste is among the sustainable materials: wood, even if pre-painted with oils of vegetable origin, it is confirmed as one of the preferred materials of bio architects. Instead, the steel components that form the joints come and return in circular processes: 99% are made from recycled scrap with manufacturing processes in which, according to European standards, polluting emissions and the amount of energy used are drastically reduced.

The proposed solution (Fig. 8 a-l), as seen, seeks a simple but effective technological content, thanks to this innovation. Taking into account the potential reuse of all the elements composing the structure, by virtue of which the product is offered at an attractive initial cost, the longevity of the components is guaranteed, unlike the others commercialized for the same purpose. Too often,

the industry focuses on immediate benefits rather than temporally extending them. The fragility and instability of the volumes commercialized for ancillary and leisure construction is evident. Faced with an attractive price for the customer, usually an inexperienced private individual, the rapid deterioration can be seen precisely in the rudimentary joining of nailed strips or in the tolerances of the corner joints. Soon it is necessary to throw away the entire structure as waste and this step is heavily depreciated by the society. Hence, adaptable design strategies can be used to reduce structural obsolescence (Bullen, 2017). It is no coincidence that the patented idea was translated into an experimental technique because of the need to build a robust economic ‘workshop-office’ ad horas<sup>7</sup>. Given that what is on the market is unsuitable for the purpose, it was decided to proceed with the construction, with the patented connection and in collaboration with

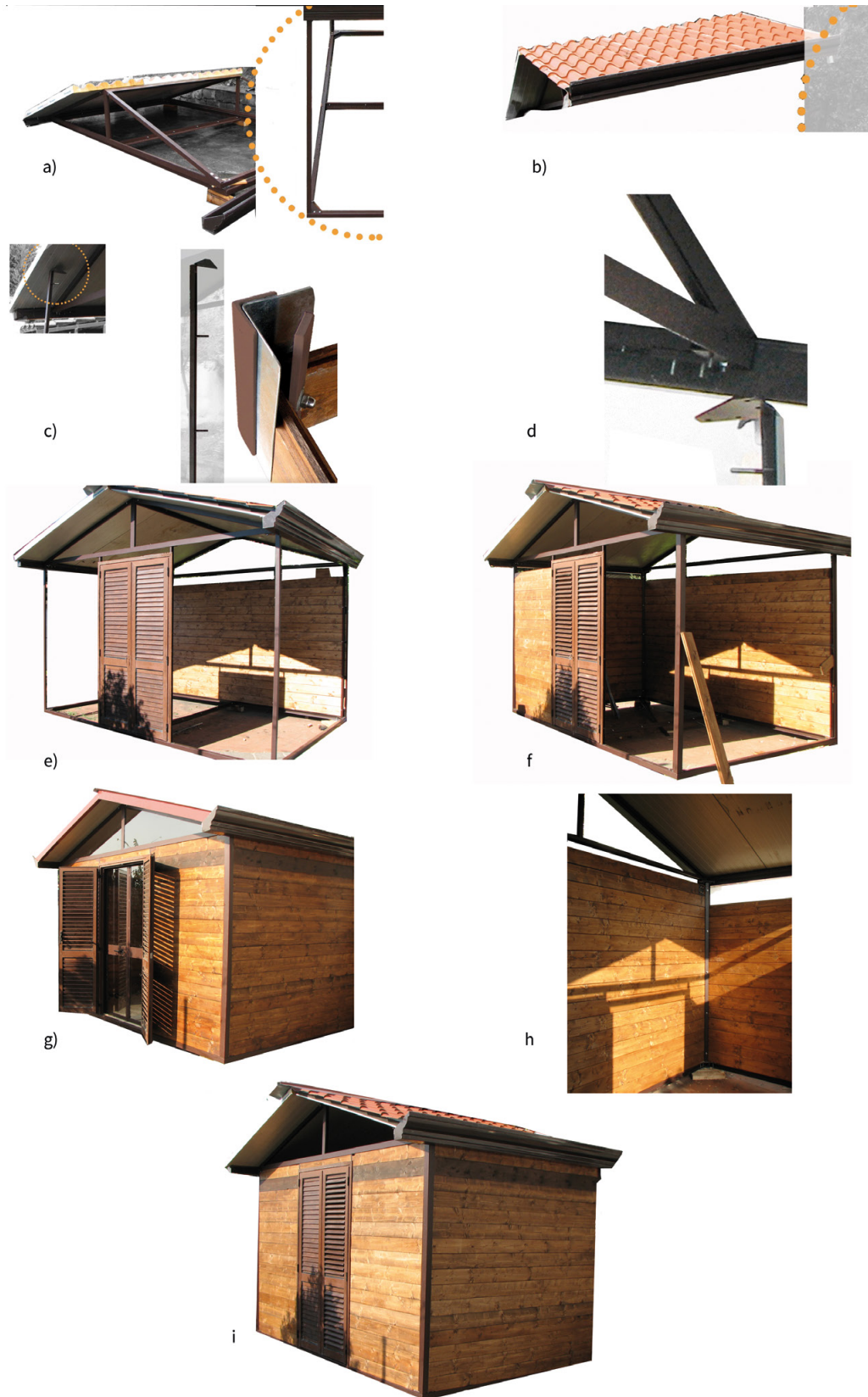

Figure 8 | The constructive process of the patented joint highlighted in its main steps.

one of the partners of the project hypothesis, a 12 sqm studio apartment at the total cost, turnkey, of 3500 euros, still in perfect condition after more than seven years from construction. The prototype demonstrated the technical, structural and aesthetic-functional performance of the system. This aspect makes the initial cost of the product reasonable even if apparently higher than in widely advertised solutions. This is because these housing solutions are subjected, as seen, to rapid degradation and to a costly and inevitable waste disposal. The assembly system allowed by the technique is in fact made both to prevent pathologies and deterioration of the wood and / or panels in the most delicate points and to allow the possible reuse of all the components used. The absence of materials to be disposed of compulsorily in the event of changes or relocations, guarantees a low impact on the environment.

Light Joints consists for the entire useful height of the perimeter walls by: vertical angular steel uprights with welded pins of 45×45×4 mm; L-shaped profiles obtained from 2 mm sheets and prepared for the purpose, with wings equal to 8cm; triangular plates welded to the two ends of the upright; counter plates and bolts for their connection to the horizontal frames; steel clamping bar.

Heavy Joints consists of: vertical angular steel uprights 60×60×6 mm with welded pins; - L-shaped profiles (equal wings 10 cm long) obtained from 2 mm sheets and prepared for the purpose with wings equal to 10 cm; - triangular plates welded to the two ends of the upright; counter plates and bolts for assembly to horizontal frames; steel clamping bar 30×15 (mm). Proposed in a “do it yourself” or “turnkey” formula, these building units can be built with or without urban connections. The customer will complete the assembly by choosing from the multitude of wood products of varying thickness and consistency available on the market: the choice can significantly affect the final price (Fig. 9).

The business idea proposed and awarded with funds V: alere (VANvitelli pEr la ricErca 2020) develops the culture of an assembly system that from an original and innovative idea has been translated into a flexible modular system for single-multiple living rooms that can be assembled and disassembled with the same speed as a tent to offer a valid alternative to the assembly of masonry veneer walls, such as to make them intact after disassembly.

The vise joints touted through the concession of use (license) by manufacturers already on the market and dedicated to the trade of assembly systems for wooden houses will participate, through already established distribution channels, in the dissemination of self-build

kits. A sort of assembly box complete with instructions will provide standardized elements or cut to size.

The components, integrating with each other, will allow with a single star key the self-construction of mini, single or multiple living rooms of a good quality level, able to satisfy a wide spectrum of needs for the supply of garden sheds-workshops, bungalows, kiosks, cabins, garages, boxes or modules. Depending on the use and the surface, clamp joints of the light type and the heavy type will be supplied.

The use of a multimedia technique documents, with the use of immersive digital methods, the various types of structures provided, allowing the people involved in the construction to learn quickly and easily understand the problems to be faced and solved.

Software widely used today will make it possible to create manuals that can be consulted online, also through the simple use of smartphones (as for example with the use of QR code)<sup>8</sup>.

#### 4. Structural System and Circular Economy

The circular economy model aims at redefining the principles of growth and consumption, focusing on positive benefits for society and on the sustainable design model based on less used of materials, recyclability and principles of technical and aesthetic durability. At European level, the Construction 2020 initiative, thematic group 3 relating to the “Sustainable use of natural resources”, has taken several steps towards a circular economy approach and greater resource efficiency of the construction industry. Among these, the definition of a set of principles for sustainable design of buildings in order to generate less construction waste and demolition, as well as facilitate the reuse and recycling of materials, products and building elements, and help reduce environmental impacts and costs of the life cycle of the building.

In February 2020, the European Commission then published a document dedicated to the circular economy in architecture. The document “Circular Economy - Principles for Building Design” defined and adapted the principles of the circular economy in architecture in:

- Durability: planning of the useful life of buildings and elements, encouraging medium and long-term attention to the design life of the main building elements, as well as the related maintenance and replacement cycles;

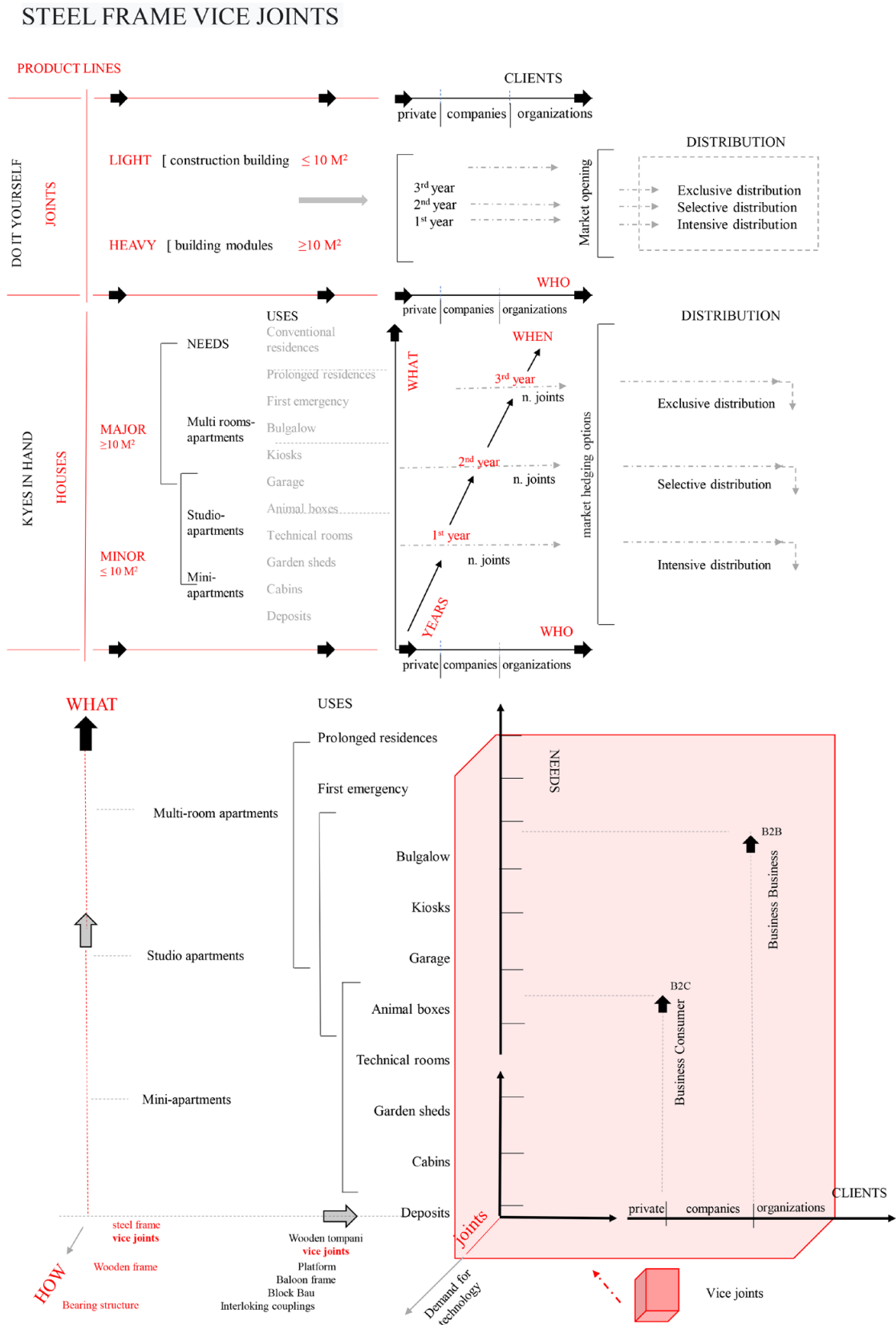

Figure 9 | Strategic Business or Business Area (Abell scheme) of the established innovative start-up Axis structure Product, promotion, distribution and pricing policy (Breakdown by lines of product / service and referred to the first three years of activity).

- Adaptability: to extend the useful life of the building as a whole, both by facilitating the continuation of the intended use and through possible future changes of use;
- Waste reduction and high quality waste management: facilitate the future circular use of building elements, components and parts, with a focus on producing less waste and the potential for high quality reuse or recycling of key building components after demolition.

This includes efforts throughout the promotion of the reuse or recycling of resources, (i.e. materials) in such a way that most of the value of the material is retained and recovered at the end of a building's life. The European commission gave also a list of best practices to be followed for a circular economy:

1. "Building by layers": elements with different life spans can be separated and removed, allowing longer lasting elements to be kept in use even when those with shorter life cycle spans require replacement.
2. the use of renewable and healthy materials
3. production processes with low environmental impact
4. materials with a high recycled content
5. durable materials
6. non-hazardous materials
7. products that can be reused, disassembled and recycled
8. create the "passports" of materials

The easy construction of this system allows changing and replacing deteriorated element without waste of time and materials. There are many joining devices used to assemble wooden structures. All, however, involve the use of nails, screws, sealants, foreign bodies to the wood fibres that accelerate their degradation. The JointsSmart here presented avoid this problem allowing also the decrease and the wastefulness of the material. On the other hand, the shape of the pillars prevent infiltration of rain protecting the wooden slats, extending their life cycle: in this way, the durability of the material is guaranteed. The resistance of the eco-sustainable systems is improved through the application of coatings (e.g. wood pre-painted with oils of vegetable origin) keeping into account the characteristics of each material used: in this way the system is durable. The use of steel and wood available locally at a low price and saving on transportation, guarantees a lowering of transport costs as well as less waste of resources, proving to be an ecological solution.

Furthermore, thanks to the use of linear and cross-joints with internal connections, the structure can be modular and reusable for other structures and buildings. In this way, the system is not only modular but also adaptable to different solutions: this fact assures the disassembling, the reuse and the recycling of the elements used in the structure.

## 5. Conclusion

The case study to which we referred was an opportunity to verify the implementation of Design for Adaptability strategies, opening up to a way of designing artifacts, capable of involving the community and obtaining a sustainable and creative design, useful for improving the possibility of interventions emergency and supplementary quality of life. Evaluating the sustainability of models, over a full life cycle, suggests that resilient structures, designed for adaptable growth, may prove to be more economically, environmentally and socially valid than structures designed in a way optimized for specific objectives. The logic that supports the circular economy, in fact, pushes us to foresee potential changes and transformations in the composition or function of a structure to be built, thus reducing the probability that it may quickly become obsolete.

To European culture in particular, which up to now enhances the architecture of historical origin (and indeed has always looked to the importance of their conservation and restoration), the acceleration of the technological, organizational and social transformations that are manifesting ever more rapidly, must today suggest greater attention to the development of an integrated approach. Concrete measures and actions are needed to face an important socio-economic paradigm shift capable of looking at the several and complex environmental and institutional challenges.

The built environment has in fact extensively shown that it has undergone the logic of the consumer economy, with both technological and typological choices that have presumed unalterable the destinations already consolidated by the social and productive structure. The development of construction processes that allow the possibility to dismantle and reassemble buildings as a whole or in some of their parts, can therefore be an objective to be carefully reconsidered. In particular, this aspect seemed to us to be particularly considered for emergency interventions in which modular flexibility, lightness, speed and simplicity of assembly, recoverability, cost-effectiveness, have been sought as the main design qualities. This innovative technique can become a real alternative to more ambiguous solutions

(recovery of containers, for example, much advocated and now entered into the social imagination thanks to the presentation of charming compositional solutions) which represent more negative than useful examples in the field of circular economy.

## Acknowledgement

The case study develops the application potential of an idea patented by the authors awarded with the V: alere funds (VANvitelli pER la ricERca 2020) for the establishment of an innovative start-up, now an academic spin-off

## Notes

- <sup>1</sup> The lack of consistency in the literature related to adaptability terminology and technology creates misinterpretations of the industry (Pinder, 2017) and (Israelsson, 2009). Remøy et al. (2011) and Manewa et al. (2016) identify the key factors for adaptable design: Utilitas firmitas and venustas (Vitruvius) are indivisible components.
- <sup>2</sup> Among the 17 Goals signed by the governments of 193 member countries of the United Nations, the Agenda - Sustainable Development Goals, SDGs (25/09/2015) - to be achieved in the environmental, economic, social and institutional spheres by 2030. The 12th and the 13th refer to the sustainability of inclusive and resilient cities and to the responsibility of consumption and production.
- <sup>3</sup> “Log building construction” (US4219977) and “Joint between two building components consisting of solid wood” (WO0163062).
- <sup>4</sup> “Wood frame construction system with prefabricated components” (US5333426); “Integrated framing system” (US20050055966).
- <sup>5</sup> “Metal Fasteners for wood construction use and a method of constructing a house” (US5666781).
- <sup>6</sup> Structural system with corner clamp joint for wooden houses (0001429838, class E04B1 34).
- <sup>7</sup> cfr. Ingegna Romana announcement n.1735 13/07/2017 PNR 2015-2020.
- <sup>8</sup> <http://goqr.me>

## References

- Adjodha, J. 2018. *Structural Design for Adaptability and Growth*.
- Bullen, P. 2011. Factors influencing the adaptive re-use of buildings. *Journal of Engineering, Design and Technology*, 9, pp. 32-46. <https://doi.org/10.1108/17260531111121459>
- Israelsson, N. 2009. ‘Factors influencing flexibility in buildings’. *Structural Survey*, 27, pp. 138-147. <https://doi.org/10.1108/02630800910956461>
- Lemer, A.C. 1996. ‘Infrastructure Obsolescence and Design Service Life’. *Journal of Infrastructure Systems*, 2(4). [https://doi.org/10.1061/\(ASCE\)1076-0342\(1996\)2:4\(153\)](https://doi.org/10.1061/(ASCE)1076-0342(1996)2:4(153))
- Mallach, E. 2006. ‘A Database Project in a Small Company (or How the Real World Doesn’t Always Follow the Book)’. *Journal of Cases on Information Technology (JCIT)*, 8(3), pp. 24-40. <https://doi.org/10.4018/jcit.2006070103>
- Manewa, A., Siriwardena, M., Ross, A., & Madanayake, U. 2016. ‘Adaptable buildings for sustainable built environment’. *Built Environment Project and Asset Management*, 6(2). <https://doi.org/10.1108/BEPAM-10-2014-0053>
- Miller, D. 1996. *City of the Century*. New York: Paperbachs.
- Pinder, J.A., Schmidt, R., Austin, S.A., Gibb, A., & Saker, J. 2017. ‘What is meant by adaptability in buildings?’ *Facilities*, 35(1/2), pp. 2-20. <https://doi.org/10.1108/F-07-2015-0053>
- Remøy, H., de Jong, P., & Schenk, W. 2011. ‘Adaptable office buildings’. *Property Management*, 29(5), pp. 443-453. <https://doi.org/10.1108/026374711111178128>
- Rockow, Z.R. 2020. ‘Qualitative & Quantitative Analyses of Existing Buildings’ Adaptability’. *All Dissertations*. 2670. Retrieved from [https://tigerprints.clemson.edu/all\\_dissertations/2670](https://tigerprints.clemson.edu/all_dissertations/2670)
- Turan, M. 2009. ‘Reconstructing The Balloon Frame: A Study In The History Of Architectonics’. *Metu Journal of The Faculty of Architecture*, 26, pp. 175-209. <https://doi.org/10.4305/METU.JFA.2009.2.10>