

## A New Freezing Box for the Managing of Semen Cryopreservation Process

Ferruccio Giametta<sup>a</sup>, Claudio Perone<sup>b,\*</sup>, Michele Di Iorio<sup>a</sup>, Giusy Rusco<sup>a</sup>, Pasquale Catalano<sup>a</sup>, Iaffaldano Nicolaia<sup>a</sup>

<sup>a</sup>Department of Agricultural, Environmental and Food Sciences, University of Molise - Via F. De Sanctis – 86100 Campobasso, ITALY

<sup>b</sup>Department of the Sciences of Agriculture, Food Natural resources and Engineering, University of Foggia, Via Napoli, 25 - 71100 Foggia, ITALY.

[claudioperone@gmail.com](mailto:claudioperone@gmail.com)

Sperm freezing is of interest not only for animal breeding. The ability to use sperm in frozen form for AI is a key factor in ensuring the long-term preservation of genetic diversity through the creation of a sperm cryobank. The most widely used freezing method involves using straws as packaging sperm, then freezing them on liquid nitrogen (N<sub>2</sub>) vapor and finally immersing them in N<sub>2</sub>. The cryosurvival of sperm cells also varies among different animal species and has been correlated with the freezing rate, i.e., the distance of the straws above the N<sub>2</sub> level. Identifying a freezing procedure that will report a fertilization rate as close as possible to that of fresh semen appears to be a challenge. Thus, there is a clear need to standardize the entire freezing process. In this research, a new device for semen cryopreservation is presented. The cryopreservation prototype allows management of the freezing rate by varying the heights of the support straws above the N<sub>2</sub> level. A stainless steel box with a suitable floating frame equipped with a support for the straws was designed and fabricated. The holder is connected to the floating frame by means of two threaded rods that allow for height adjustment by screwing in appropriate guides. Two K-type thermocouples were used, one to measure the temperature of the nitrogen vapor at the height of the support and the other to measure the temperature of the semen inside the straw. In this way, different freezing protocols can be compared. By managing the freezing rate, the sperm freezing procedure, which is specific to animal species, could be standardized and thus variability in results could be minimized. In addition, improved cryosurvival and post-freezing sperm fertilization rates are expected.

### 1. Introduction

Artificial insemination has arguably been the most important practice contributing to the advancement of animal production (Bailey et al., 2003). The many advantages of artificial insemination are enhanced when semen is cryopreserved and stored for extended periods. The ability to use semen in frozen form for AI is a key factor in ensuring the long-term preservation of genetic diversity through the creation of a semen cryobank (Iaffaldano et al., 2016 a, b). Frozen semen also has several practical advantages for commercial production of many animal species.

The Zooculture group of the AAA Department -University of Molise has been engaged for several years in the identification of effective cryopreservation procedures for semen of different animal species. Recently, thanks to three funded projects, one of them is a European project (Life Nat.Sal.Mo) and two are national projects funded by the Ministry of Agriculture Food and Forestry (MiPAAF) and all three have a common goal in safeguarding the biodiversity of:

1. native populations of Mediterranean trout: project "Recovery of *S. macrostigma*: Application of innovative techniques and participatory governance tools in the rivers of Molise" (Life Nat.Sal. Mo);
2. local poultry breeds: project "Protection of the Biodiversity of Italian Poultry Breeds" (TuBAVl);

3. Italian rabbit breeds: project "The rabbit breeding of the future: welfare and sustainability of Italian rabbit farms" (Cun-Fu project).

Accordingly, milestones of the present projects are the creation of cryobanks of semen for the preservation of the precious Italian heritage. However, a fundamental prerequisite for the creation of a sperm cryobank is the development of a successful sperm freezing protocol.

Despite the great interest in sperm cryopreservation, it has not yet led to satisfactory results in most mammals, birds and fish due to a considerable percentage of spermatozoa losing their fertility during freeze-thaw. In many species, this loss of fertility is substantial, making cryopreserved semen impractical for routine use. Cryopreservation of semen is species-specific and involves several steps, each of which affects sperm structure and function (Garner et al., 1999; Bailey et al., 2003):

- extension,
- cooling,
- addition of cryoprotectant,
- freezing rate,
- thawing rate.

Deleterious effects result from osmotic stress and temperature changes produced during cooling, freezing, and re-warming; ice crystal formation is one of the main biophysical mechanisms of sperm death (Swain and Smith, 2010). A major challenge for cell survival during cryopreservation is the lethality of the intermediate temperature zone (-15 to -60 °C), which is crossed twice during the cryogenic cycle when cells are cooled and rewarmed (Gao and Critser, 2000). Thus, there is a clear need to standardize the whole freezing and thawing process to minimize variability in results. Consequently, it is extremely important to identify an optimal cryopreservation protocol (Casula et al., 2015).

The rate of freezing has a large impact on the quality of sperm and its ability to fertilize after cryopreservation (Holt 2000; Mocé et al. 2010). When semen is frozen over N<sub>2</sub> vapor, the distance between the straw and the N<sub>2</sub> bath determines the thermal gradient during the freezing phase when the transition from liquid to solid state occurs (Madeddu et al., 2016).

Here we present a new prototype freezing box for seed cryopreservation. It allows to manage the height of straws above the free surface of liquid nitrogen during the exposure time, thus, customizing the freezing process and facilitating the collection of straws.

## 2. Materials and methods

### 2.1 Experimental freezing box

The prototype is designed to be used for freezing trout, turkey, and rabbit within the financed projects. The cryopreservation procedure is species specific; the semen must be frozen at different heights on the surface of the liquid nitrogen vapor depending on the species considered, as shown below.

- **Trout sperm.** Sperm collected from individual males will be diluted in a final extender concentration of 0.15 M glucose and 7.5% methanol, loaded into 0.25 mL plastic straws to achieve a final sperm concentration of  $3 \times 10^9$  sperm/mL. After equilibration, the straws should be frozen by exposure to liquid nitrogen vapor at 3 cm above the liquid nitrogen level for 5 min. Then, the straw will be submerged and stored in liquid nitrogen (Rusco et al., 2020). Finally, semen will be thawed at 40 °C/5 s to evaluate seminal quality parameters and reproductive performance.
- **Turkey sperm.** Sperm collected from turkeys by abdominal massage will be diluted with Tselutin extender and cooled at 4 °C for 25 min. Subsequently, pre-extended semen is further diluted (1:1, v/v) with freezing medium consisting of Tselutin extender containing 20% dimethylsulfoxide (DMSO) and 1 mM Ficoll 70, to achieve a final sperm concentration of  $3 \times 10^9$  sperm/mL. The diluted semen will then be loaded into 0.25 mL straws using a manual microaspirator (IMV-Technologies, Piacenza, Italy) and then equilibrated at 4 °C for 20 min. Straws will be frozen by exposure to liquid nitrogen vapor at 10 cm above the liquid nitrogen level for 10 min and then were immersed and stored in liquid nitrogen. Semen will then be thawed at 50 °C for 10 sec to assess seminal quality parameters and reproductive performance (Di Iorio et al., 2020 a,b).
- **Rabbit sperm.** Sperm samples will be diluted in a 1:1 (v:v) ratio with a freezing extender i.e. tris-citric-glucose (TCG) acid containing 16% DMSO and 0.1 M sucrose. The extended seed is then filled into 0.25 mL plastic straws and equilibrated at 5 °C for 45 min. After that, the straws will be allocated horizontally 5 cm above a surface of liquid nitrogen for 10 min and immersed in liquid nitrogen for

storage (Iaffaldano et al., 2014). Finally, semen will be thawed at 50 °C for 10 sec to determine seminal quality parameters and reproductive performance.

Other freezing levels will be tested using the new freezing box and the results of the thawed sperm quality will be compared with those obtained using the standard freezing procedure and equipment.

Based on the procedures described above, it becomes essential to have a highly flexible tool that allows a specific procedure to be implemented based on the species being treated. For this purpose, the experimental freezing box was first designed by means of 3D CAD and then fabricated to perform a preliminary test of a vertical freezing temperature distribution during the process. Figure 1 shows the 3D design and its main components. Figure 1a shows the overall assembly of the freezing box. It consists of a stainless-steel box measuring 530 mm in length, 350 mm in depth, and 275 mm in height. The straw holder (Figure 1b) is made of the same material as the box and was connected to the floating frame via two sliding rods (Figure 1c). Two screws allow the position of the straw holder to be adjusted by displaying its level above the liquid nitrogen with a level indicator.

To measure the nitrogen vapor temperature and the temperature inside a representative straw, a special housing for a data logger was provided. To avoid asymmetry and deviation of the center of mass position, a plate with adequate weight was made to balance the data logger installation. Two polystyrene floats were appropriately designed to support the full weight of the device. The box was closed by means of a lid formed by two symmetrical lids. A top view of the device without lids is shown in Figure 1d. Finally, the whole box was insulated with 3 cm of Styrofoam to prevent heat loss.

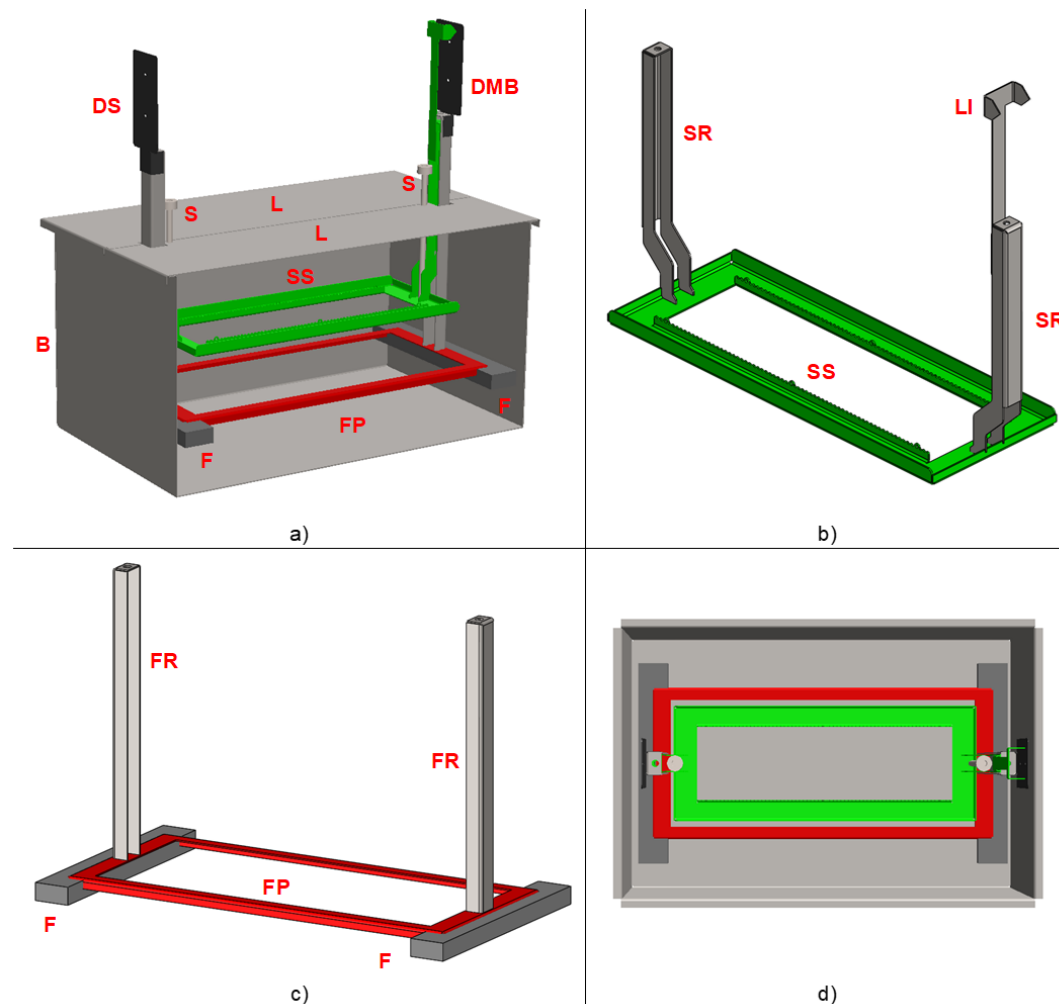

Figure 1: Freezing box design. a) – freezing box assembly; b) – straws support; c) – floating frame; d) – top view. B – Box; DMB – Data logger Mass Balance; DS – Data logger Support; F – Float; FP – Floating plate; FR; Floating Rod; L – Lid; LI – Level Indicator; S – Screw; SR – Sliding Rod; SS – Straws Support.

## 2.2 Experimental procedure

The main function of the new prototype is to allow the freezing process to be managed by continuously adjusting the position of the straws above the free surface of the liquid nitrogen. This is done based on the characteristics of the freezing box described in section 2.1. To test the device, a freezing procedure was designed. Specifically, a protocol was set up in which, starting at 10 cm above the free nitrogen surface, the height of the straw holder was lowered by 1 cm every minute, for a total freezing time of 10 minutes. A Wi-Fi data logger (Figure 2a) (Testo Saveris 2) was used to measure the temperature of the nitrogen vapor near the straw holder, and within a representative straw. It was equipped with two flexible K thermocouples (Figure 2b), one with a tip size of 3 mm to be inserted into the straw, and the other with a 5 mm tip to be immersed in the nitrogen vapor. Both thermocouples have a class 1 accuracy (according to EN 60584-2), a temperature measurement range  $-200\text{ }^{\circ}\text{C} - 1000\text{ }^{\circ}\text{C}$ , and a reaction time of 5 seconds (which also represents the sampling time). Installation of the data logger and probes was possible by means of a stand, and its total weight was balanced by a plate of the same weight on the opposite rod. In detail, the data logger and the two probes are integral with the sliding rod, so as to follow the movement of the straw holder. This mechanism is essential to manage the freezing procedure according to the treatment that the sperm of the specific species must undergo.

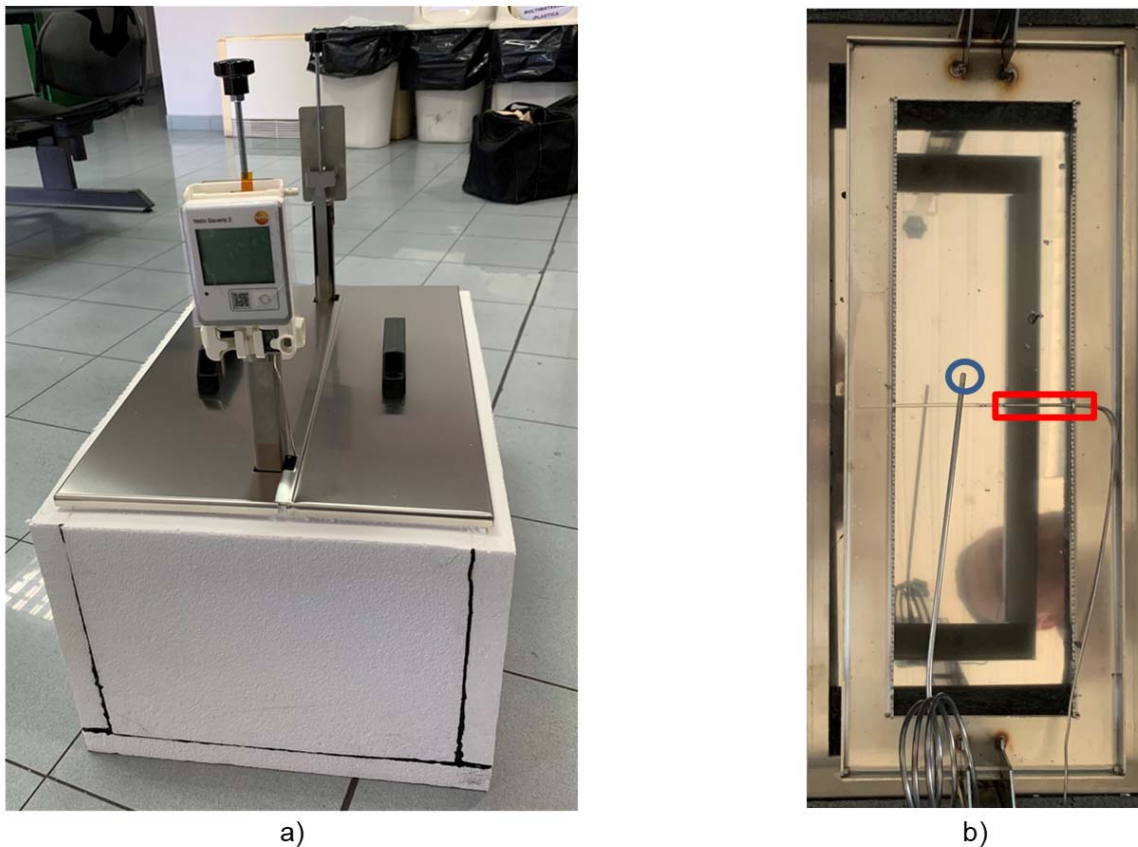

Figure 2: a) Data logger installation; b) Probes installation – straw probe in red rectangle, and nitrogen vapor probe in blue circle.

## 3. Results and discussions

Freezing speed is one of the most important parameters of sperm quality after cryopreservation (Holt, 2000; Mocé et al., 2010; Iaffaldano et al., 2016 a,b). In turn, when liquid nitrogen is used to freeze semen, the cooling rate is highly influenced by the height of the straws above its free surface. However, only freezing procedures in which different heights of the straw holder are fixed for the entire freezing time are found in the literature.

In particular, currently available freezing boxes do not allow the height of the floating grid to be adjusted during the freezing process.

Figure 3 shows the temperature of nitrogen vapor over liquid nitrogen during a preliminary test, according to the experimental procedure described in 2.2. The temperature of the two thermocouples was essentially the same since the straws were empty. In fact, the purpose of the research was to develop a new prototype freezing box capable of monitoring and managing different freezing procedures (for different animal breeds). The stability of the temperature values in each position highlights the correct isolation of the prototype. It can also be seen that the vertical distribution of temperature between 10 cm and 2 cm is almost linear, with a slight increase in slope for lower heights.

The ability to monitor in real time the nitrogen vapor temperature at the location of the straw holder can lead to a better adjustment of the provided cooling. In fact, depending on the number of straws and its thermo-physical characteristics, the cooling rate is directly proportional to the temperature difference. This will allow to control the freezing curve step by step and to operate the freezing speed adjustment. In fact, the freezing speed has a deep influence on the nucleation of crystals, in particular on their number and size. For example, faster freezing leads to more small crystals with less membrane damage.

Based on the results shown in Figure 3, it is possible to increase the freezing rate by varying the speed and direction of the straw holder. Faster freezing is possible by starting from a lower initial height and moving to higher heights. Slower freezing is possible through a reverse procedure.

Finally, it is worth mentioning that the box is also equipped with a probe to be inserted into a reference straw. This is very important, since by combining the measurements of the two probes, it is possible to know the precise temperature difference at each position, thus allowing to refine the regulation technique.

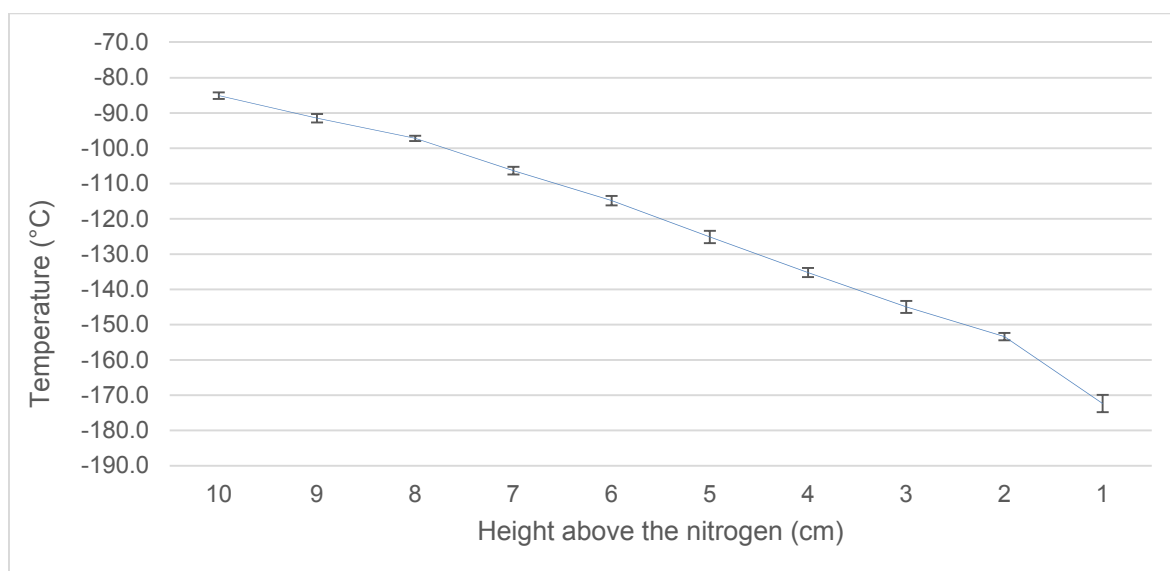

Figure 3: Temperature distribution at different heights.

#### 4. Conclusions

A new prototype freezing box has been designed and fabricated. This device allows to properly adjust the freezing rate and customize the freezing curve that results as species specific. The control is done through a movable straw holder. The holder is connected to a floating frame by two screws, and by operating these two screws it is possible to adjust its height above the liquid nitrogen. The good insulation of the box allows an almost linear distribution of vertical temperature away from the nitrogen surface. Two thermocouples give real-time information about the temperature difference between the sperm inside the straw and the nitrogen vapor at that specific location. This allows quick decisions to be made about how to change the position of the straw holder to achieve the desired effect. Ultimately, the new prototype appears to provide adequate control of the freezing procedure.

The development of a freezing box that is repeatable, does not leak liquid nitrogen, and is economically viable will allow for the optimization of the seed freezing procedure for the species considered and others. In light of this consideration, an improvement in the quality of post-freezing semen and thus its fertilizing capacity in vivo is expected. In addition, a straw collection system is also planned to streamline the time.

## References

- Bailey, J.L., Morrie, A., Cormier, N., 2003, Semen cryopreservation: successes and persistent problems in farm species, *Canadian Journal of Animal Science*, 83, 393–401.
- Casulaa, E., Asunib, G. P., Sogosc, V., & Cincotti, A. (2015). hMSCs from UCB: isolation, characterization and determination of osmotic properties for optimal cryopreservation. *Chemical Engineering Transactions*, 43, 265-270.
- Di Iorio, M., Rusco, G., Iampietro, R., Colonna, M.A., Zaniboni, L., Cerolini, S., Iaffaldano, N., 2020a, Finding effective freezing protocol for turkey semen: benefits of Ficoll as non-permeant cryoprotectant and 1:4 as dilution rate. *Animals*, 10, 42.
- Di Iorio, M., Rusco, G., Iampietro, R., Maiuro, L., Schiavone, A., Cerolini, S., Iaffaldano, N., 2020b, Validation of the turkey semen cryopreservation by evaluating the effects of two diluents and the inseminating doses, *Animals*, 10, 1329.
- Gao, D., Critser, J.K., 2000, Mechanisms of cryoinjury in living cells. *ILAR Journal*, 41, 187–196.
- Garner, D.L., Thomas, C.A., Gravance, C.G., 1999, The effect of glycerol on the viability, mitochondrial function and acrosomal integrity of bovine spermatozoa, *Reproduction in domestic animals*, 34, 399–404.
- Holt, W.V., 2000, Fundamental aspects of sperm cryobiology: the importance of species and individual differences, *Theriogenology*, 53, 47–58.
- Iaffaldano, N., Di Iorio, M., Rosato, M.P., Manchisi, A., 2014, Cryopreservation of rabbit semen using nonpermeable cryoprotectants: Effectiveness of different concentrations of low-density lipoproteins (LDL) from egg yolk versus egg yolk or sucrose, *Animal Reproduction Science*, 151, 220–228.
- Iaffaldano, N., Di Iorio, M., Manchisi, A., Esposito, S., Gibertoni, P.P., 2016a, Effective freezing rate for semen cryopreservation in endangered Mediterranean brown trout (*Salmo trutta macrostigma*) inhabiting the Biferno river (South Italy), *Zygote*, 24, 668–675.
- Iaffaldano, N., Di Iorio, M., Miranda, M., Zaniboni, L., Manchisi, A., Cerolini, S., 2016b, Cryopreserving turkey semen in straws and nitrogen vapour using DMSO or DMA: Effects of cryoprotectant concentration, freezing rate and thawing rate on post-thaw semen quality, *British Poultry Science*, 57, 264–270.
- Madeddu, M., Mosca, F., Abdel Sayed, A., Zaniboni, L., Mangiagalli, M.G., Colombo, E., Cerolini, S., 2016, Effect of cooling rate on the survival of cryopreserved rooster sperm: Comparison of different distances in the vapor above the surface of the liquid nitrogen, *Animal Reproduction Science*, 171, 58-64.
- Mocé, E., Lavara, R., Vicente, J.S., 2010, Effect of cooling rate to 5°C, straw size and farm on fertilizing ability of cryopreserved rabbit sperm, *Reproduction in domestic animals*, 45, e1–e7.
- Rusco, G., Di Iorio, M., Iampietro, R., Esposito, S., Gibertoni, P.P., Penserini, M., Roncarati, A., Iaffaldano, N., 2020, A simple and efficient semen cryopreservation method to increase the genetic variability of endangered Mediterranean brown trout inhabiting Molise rivers. *Animals*, 10, 403.
- Swain, J.E., Smith, G.D., 2010, Cryoprotectants. In *Fertility Cryopreservation*; Chian, R.C., Quinn, P., Eds. Cambridge University Press: New York, NY, USA.; pp. 24–38.