

105090  
#1

# Final Report Miniaturized Multi-band-Antenna

## GEDC-Cartiza

Prof. Joy Laskar

Georgia Electronic Design Center

# Antenna Element Design

# Initial Antenna Configuration

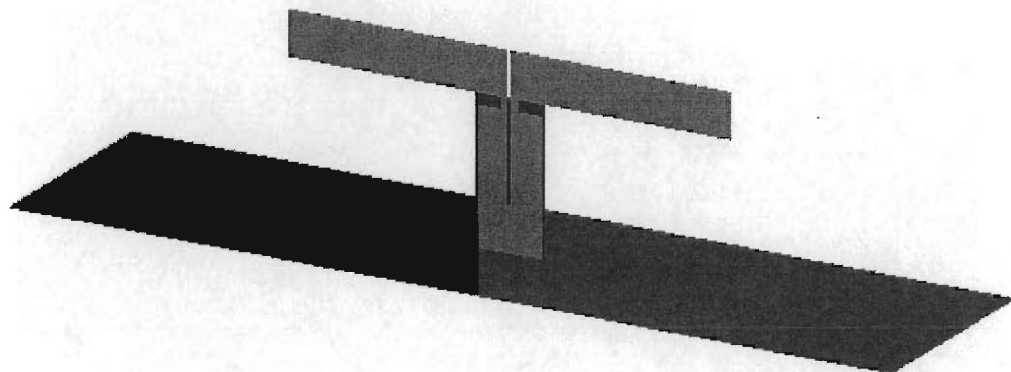

# Return Loss

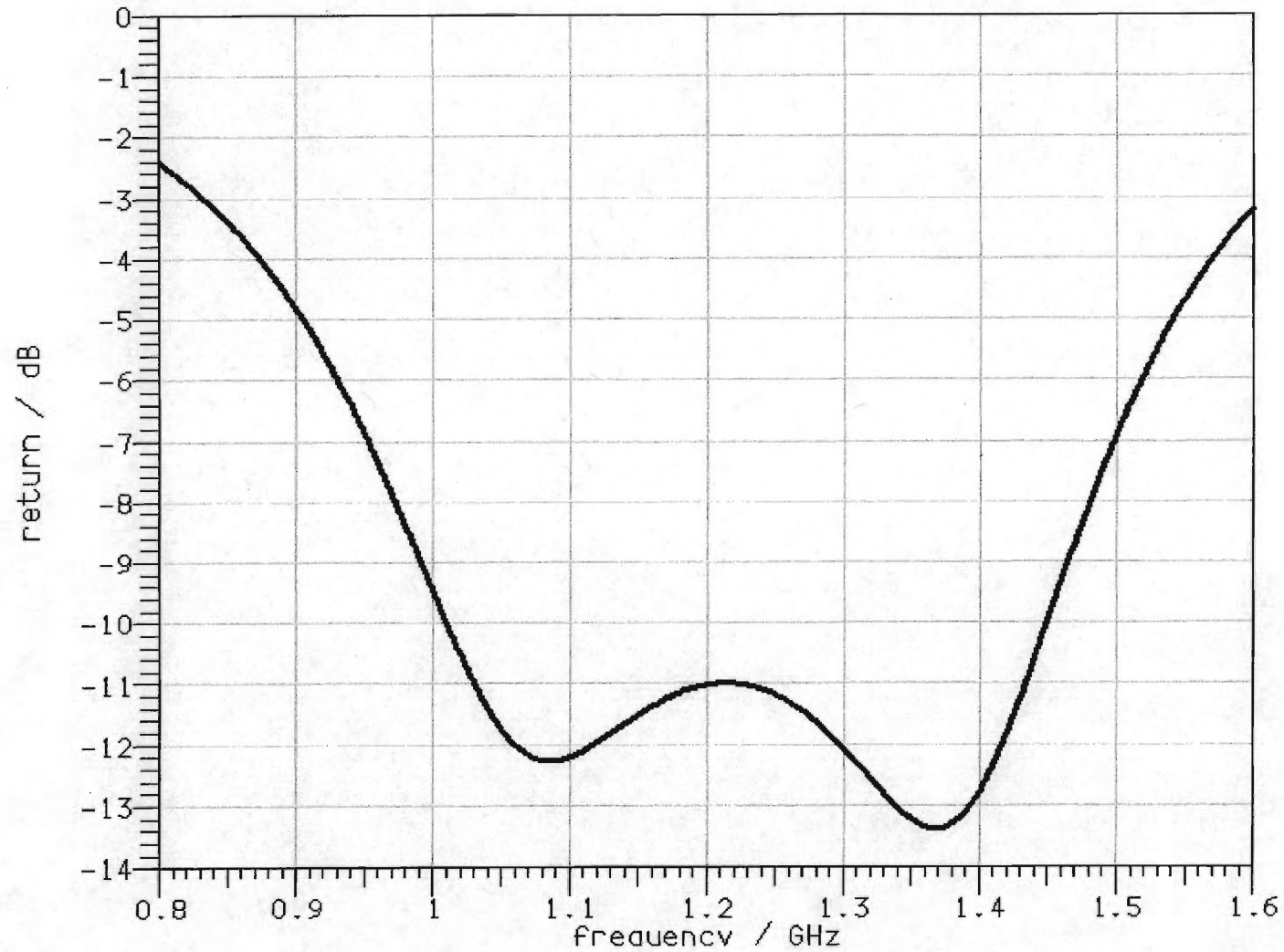



# Radiation pattern (1.0 GHz)

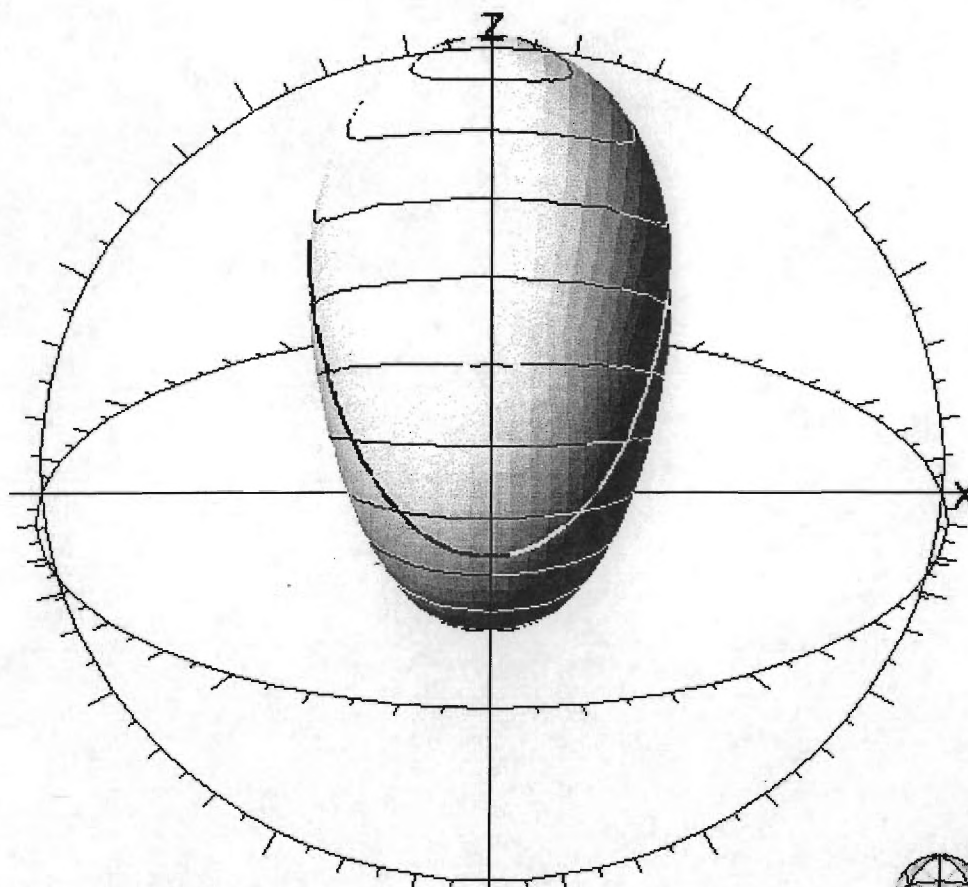

Directivity: 6.199dBi  
Polrzn. Loss: 0.000dB  
Material Loss: Not Known  
Mismatch: -519.090m dB  
Gain: 5.680dBi

Ant Eff: 88.734%  
Rad Eff: 100.000%

Scale: Linear:  $-\infty$  to 0dB-directivity  
Contour at: -3 dB-directivity  
Frequency: 1GHz



|E|

# Radiation pattern (1.2 GHz)

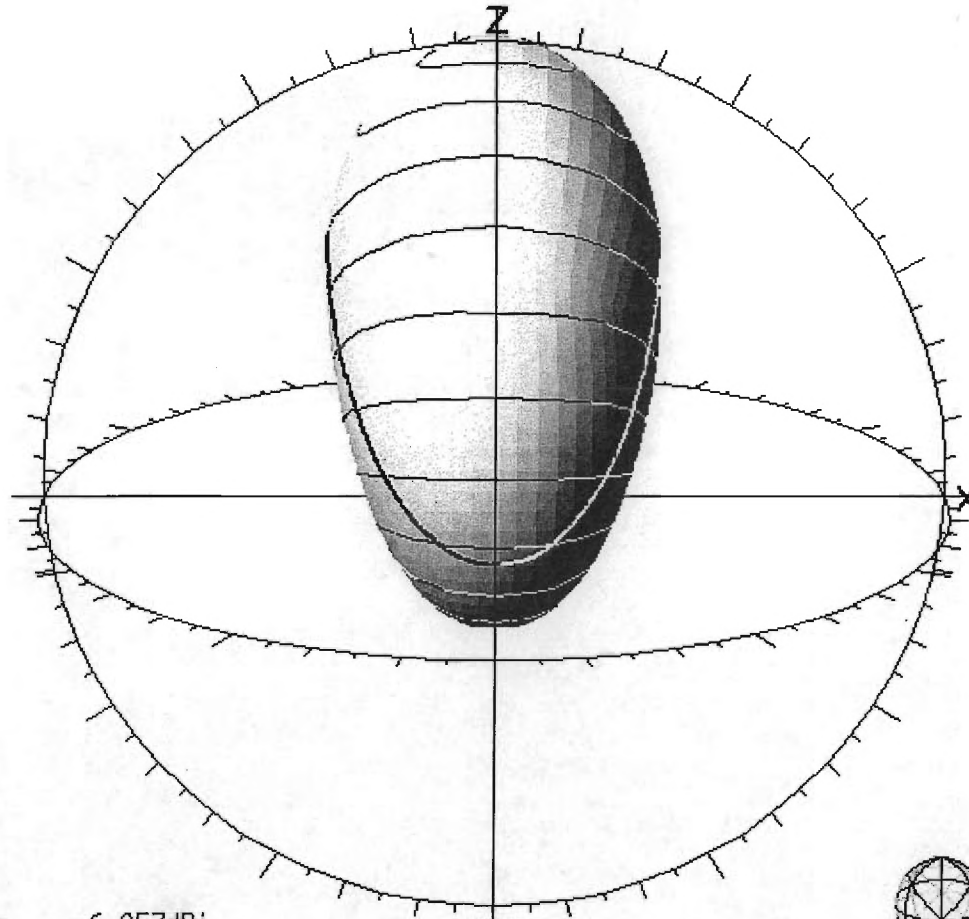

Directivity: 6.257dBi  
Polrzn. Loss: 0.000dB  
Material Loss: Not Known  
Mismatch: -357.476m dB  
Gain: 5.900dBi

Ant Eff: 92.098%  
Rad Eff: 100.000%

Scale: Linear:  $-\infty$  to 0dB-directivity  
Contour at: -3 dB-directivity  
Frequency: 1.2GHz



|E|

# Radiation pattern (1.4 GHz)

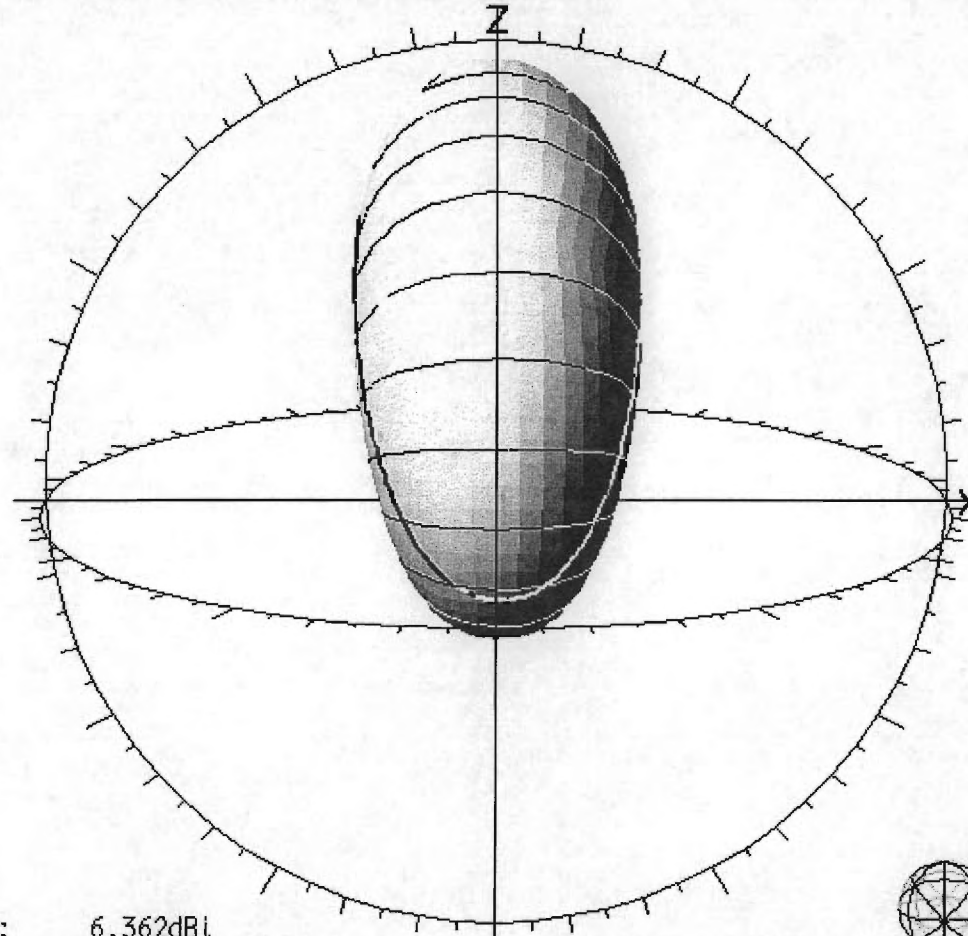

Directivity: 6.362dBi  
Polrzn. Loss: 0.000dB  
Material Loss: Not Known  
Mismatch: -235.687m dB  
Gain: 6.126dBi

Ant Eff: 94.718%  
Rad Eff: 100.000%

Scale: Linear:  $-\infty$  to 0dB-directivity  
Contour at: -3 dB-directivity  
Frequency: 1.4GHz

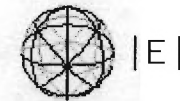

|E|

EW01

# A compact antenna element

- Configuration

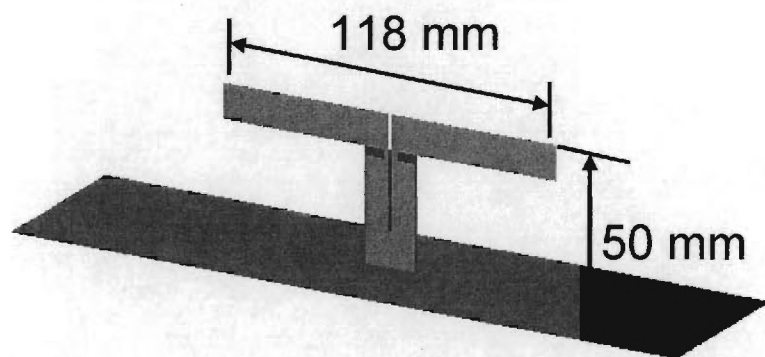

Previous

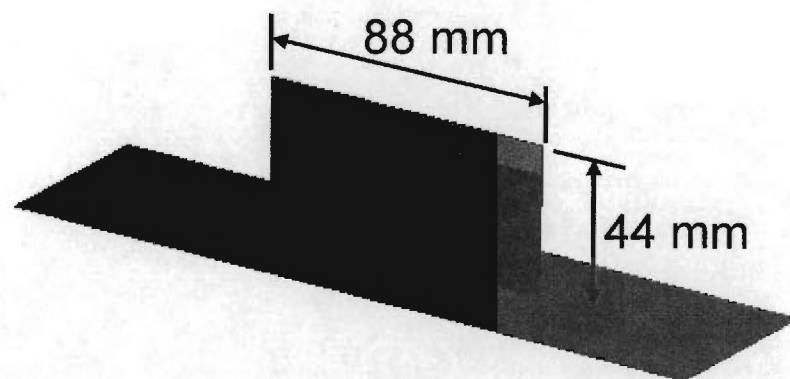

Improved

# Return loss

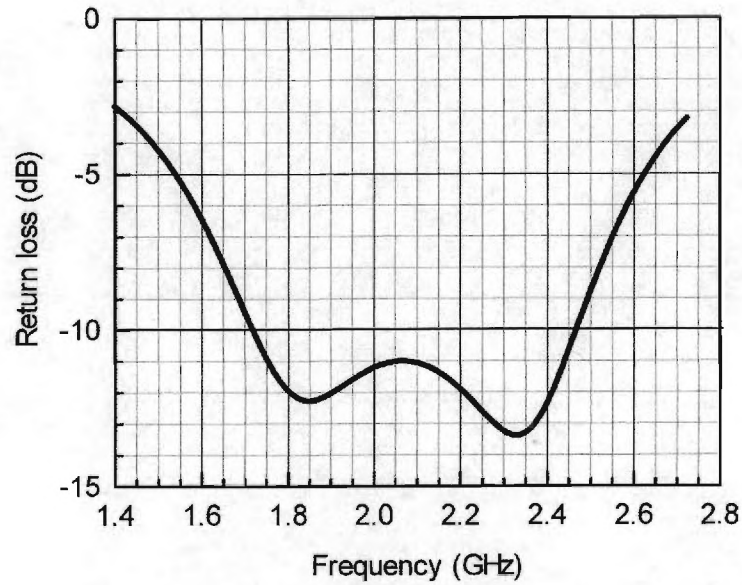

Previous  
(Bandwidth=35%)

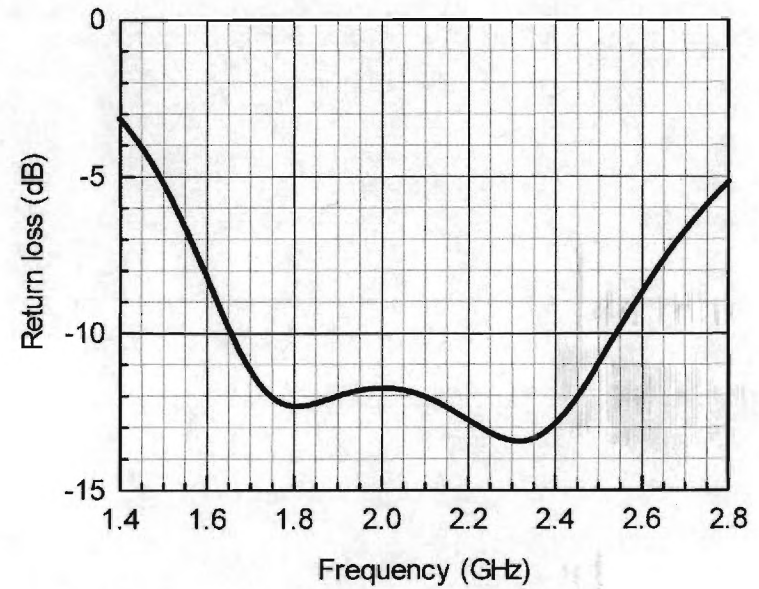

Improved  
(Bandwidth=42%)

# Multi-band Array of Antenna Design

# 8-Element Antenna Array

- Configuration

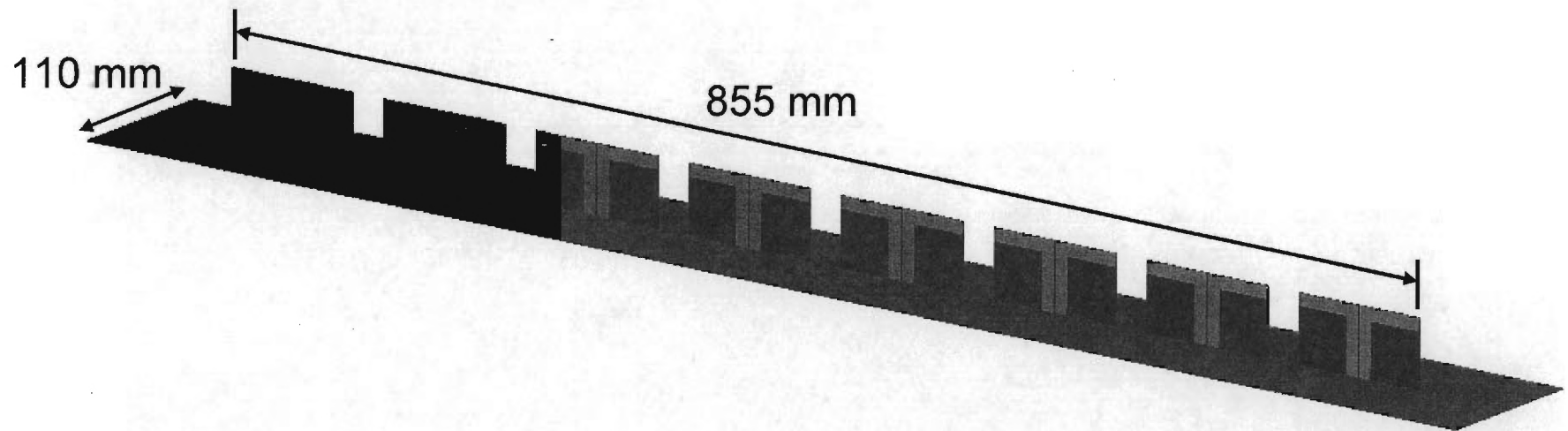



● Radiation patterns - No Radome

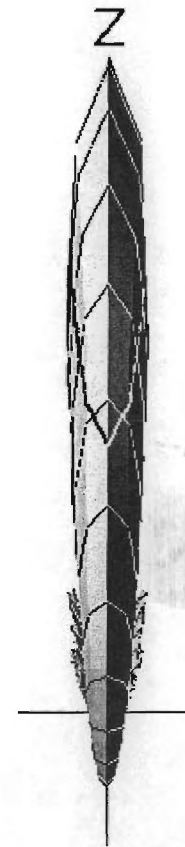
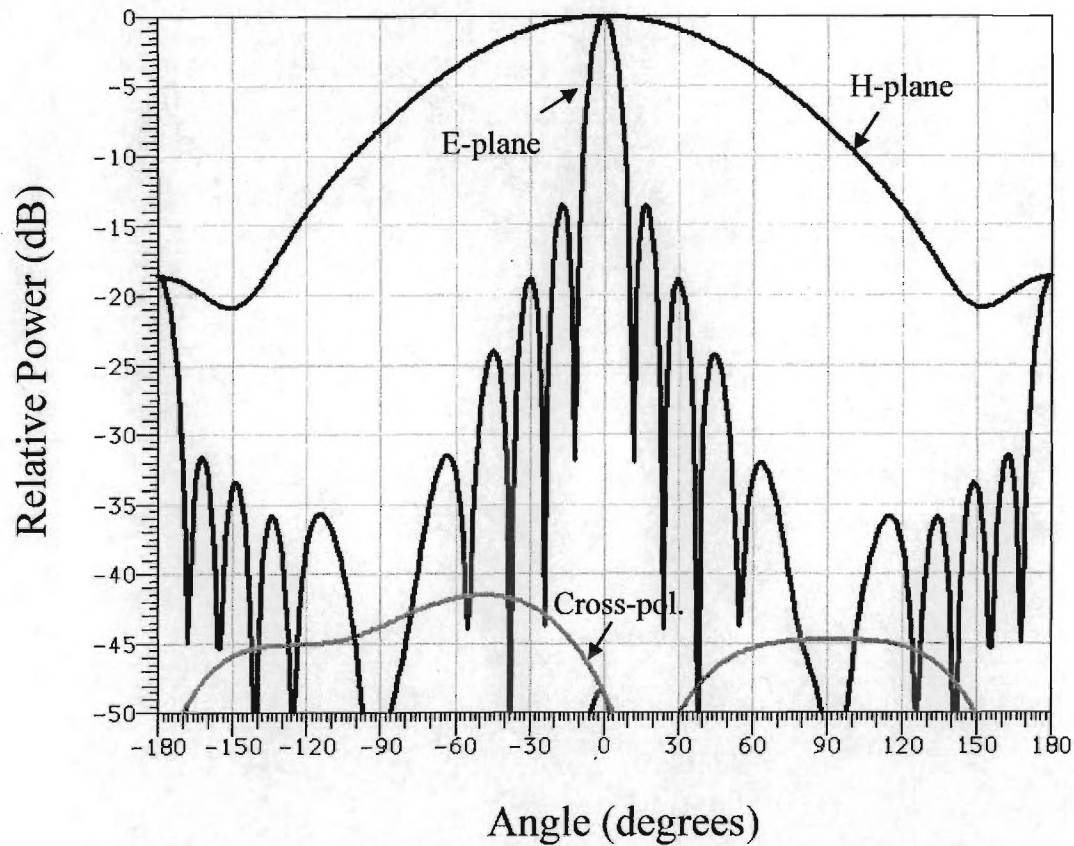

At 1.7 GHz  
(Directivity=15.0 dBi)



● Radiation patterns - No Radome

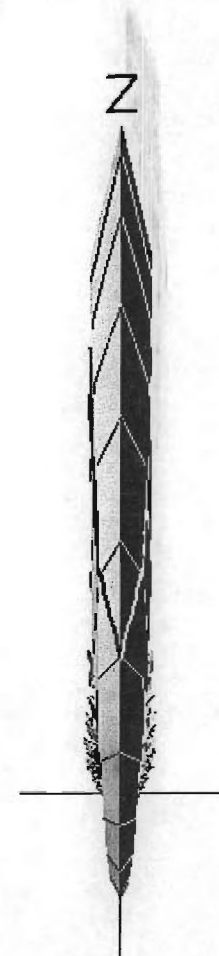
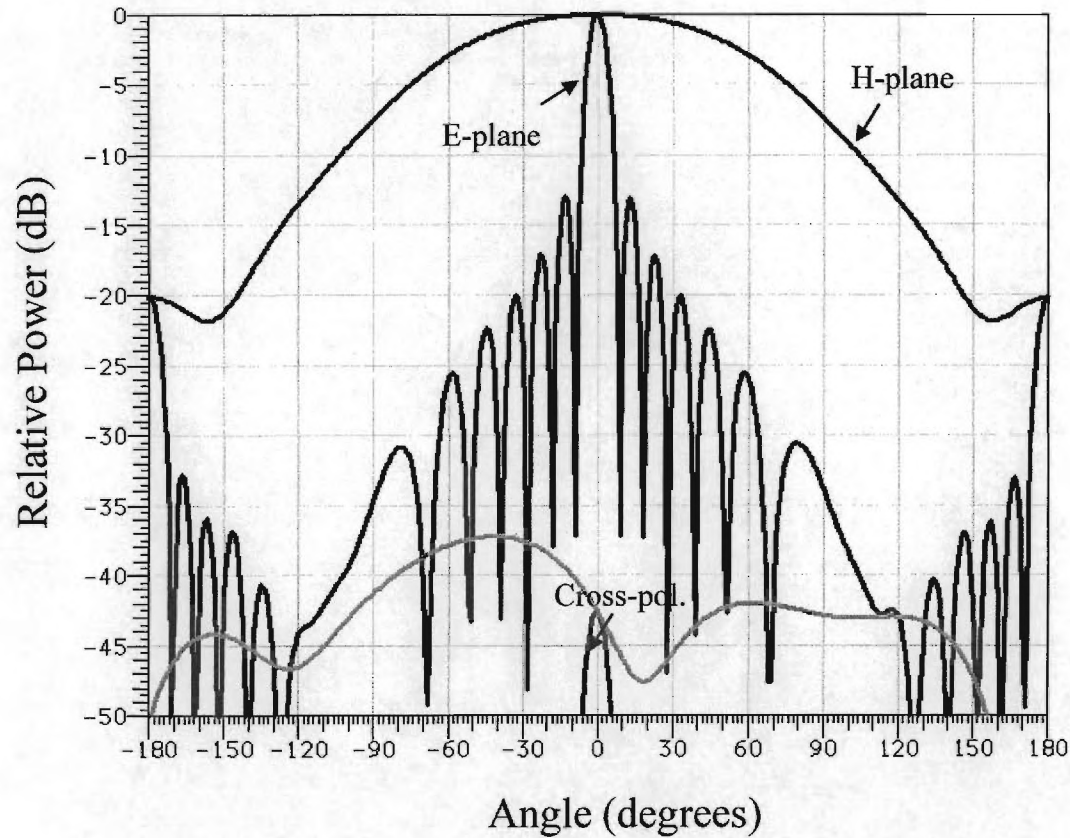

At 2.1 GHz  
(Directivity=15.6 dBi)

● Radiation patterns - No Radome

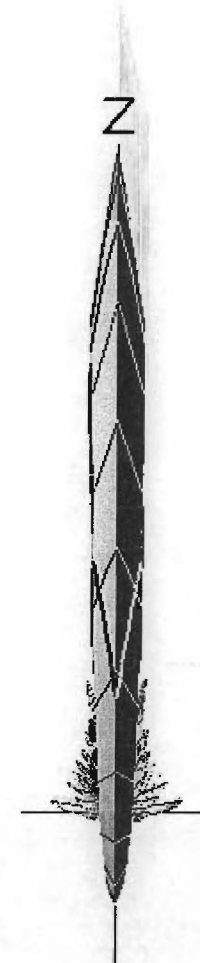
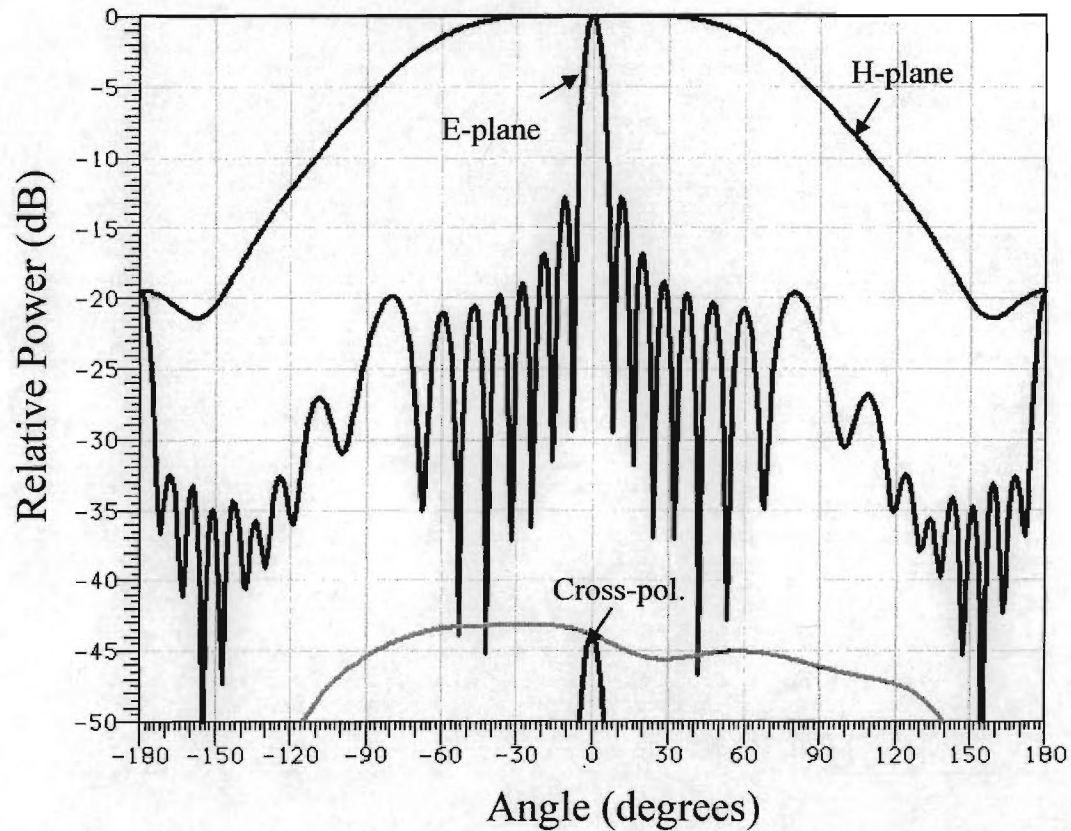

At 2.5 GHz  
(Directivity=15.4 dBi)

# 8-Element Antenna Array with Radome

- Configuration

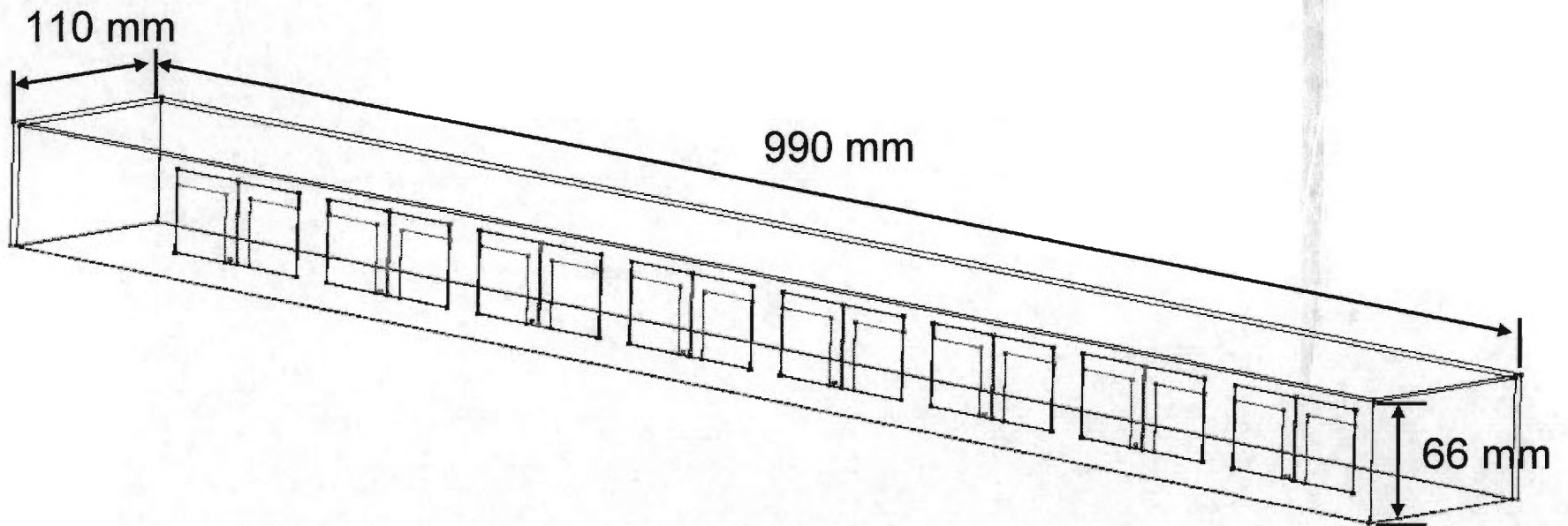

Radome Thickness=2.2 mm

$$\epsilon_r=4.5$$

● Radiation patterns : With Radome

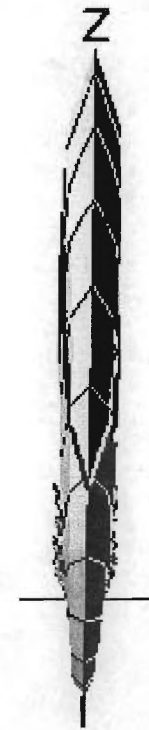
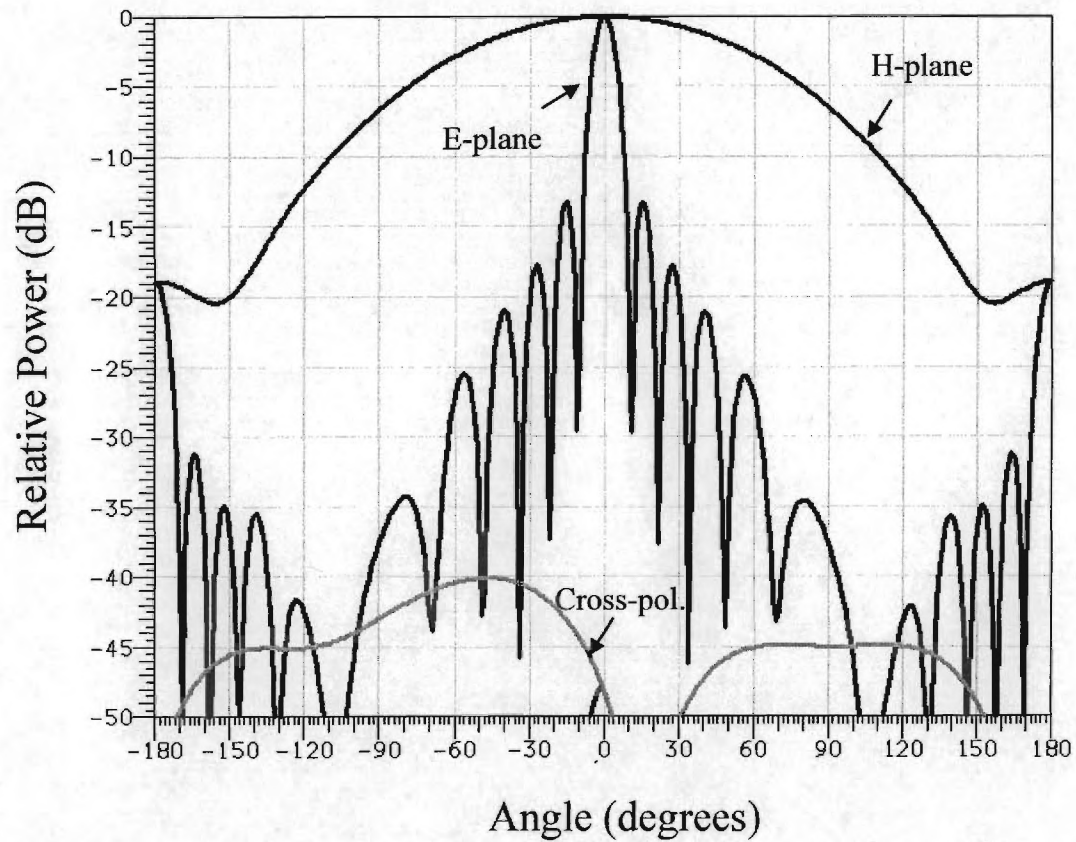

At 1.7 GHz  
(Directivity=14.9 dBi)

● Radiation patterns : With Radome

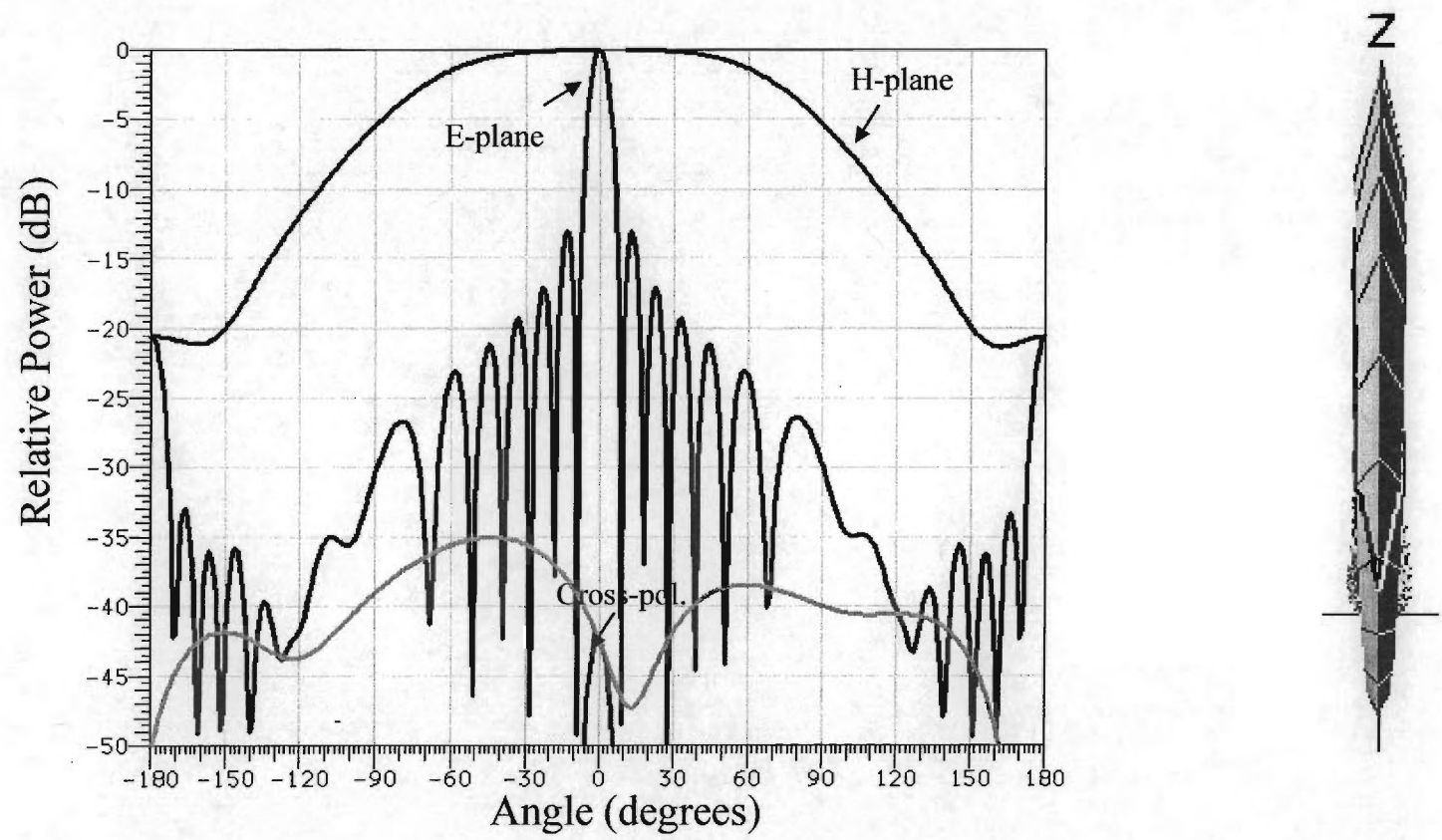

At 2.1 GHz  
(Directivity=14.8 dBi)



● Radiation patterns : With Radome

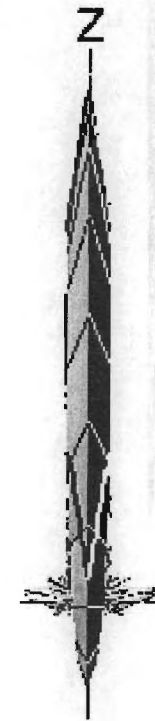
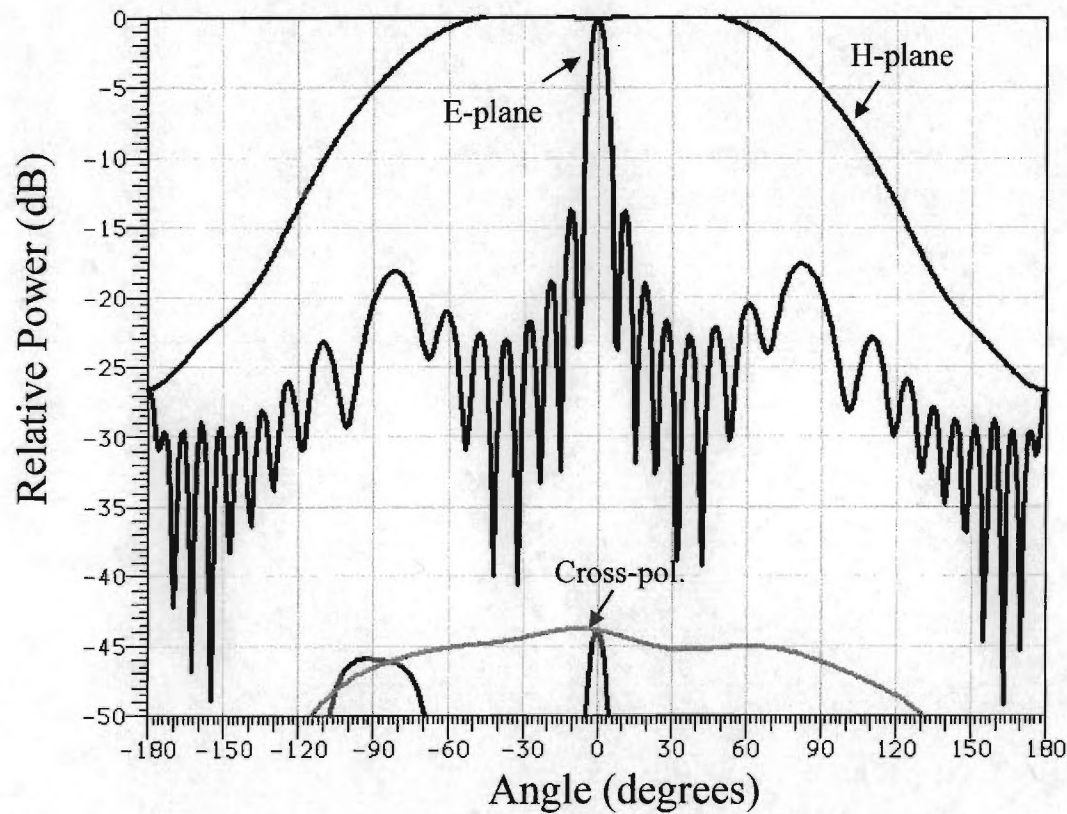

At 2.5 GHz  
(Directivity=15.5 dBi)

# 2x4-Element Antenna Array for miniaturization

- Configuration

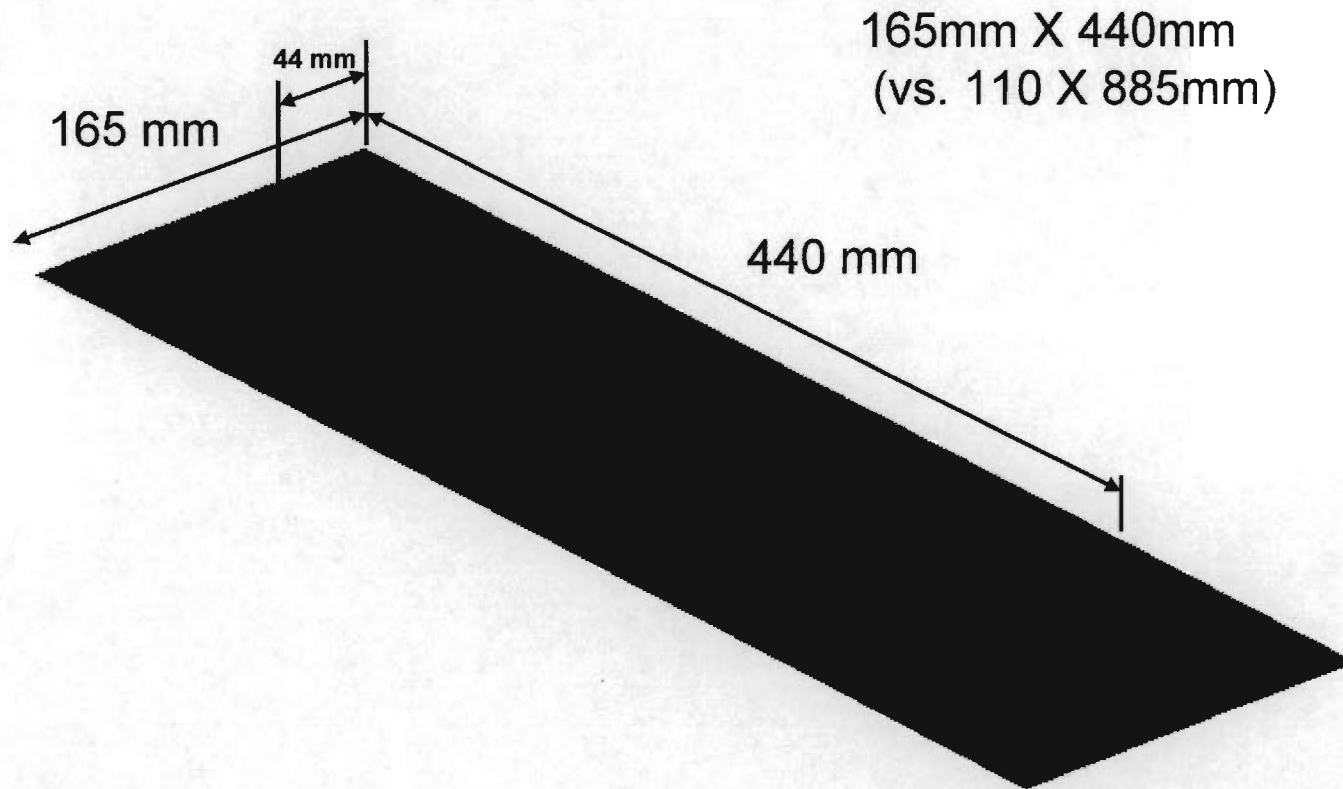

● Radiation patterns

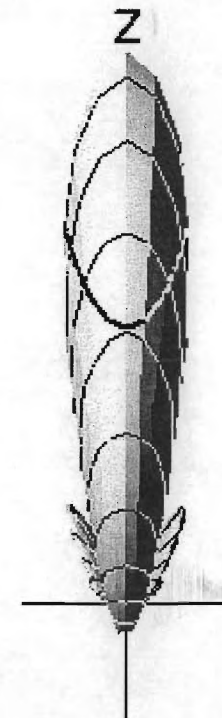
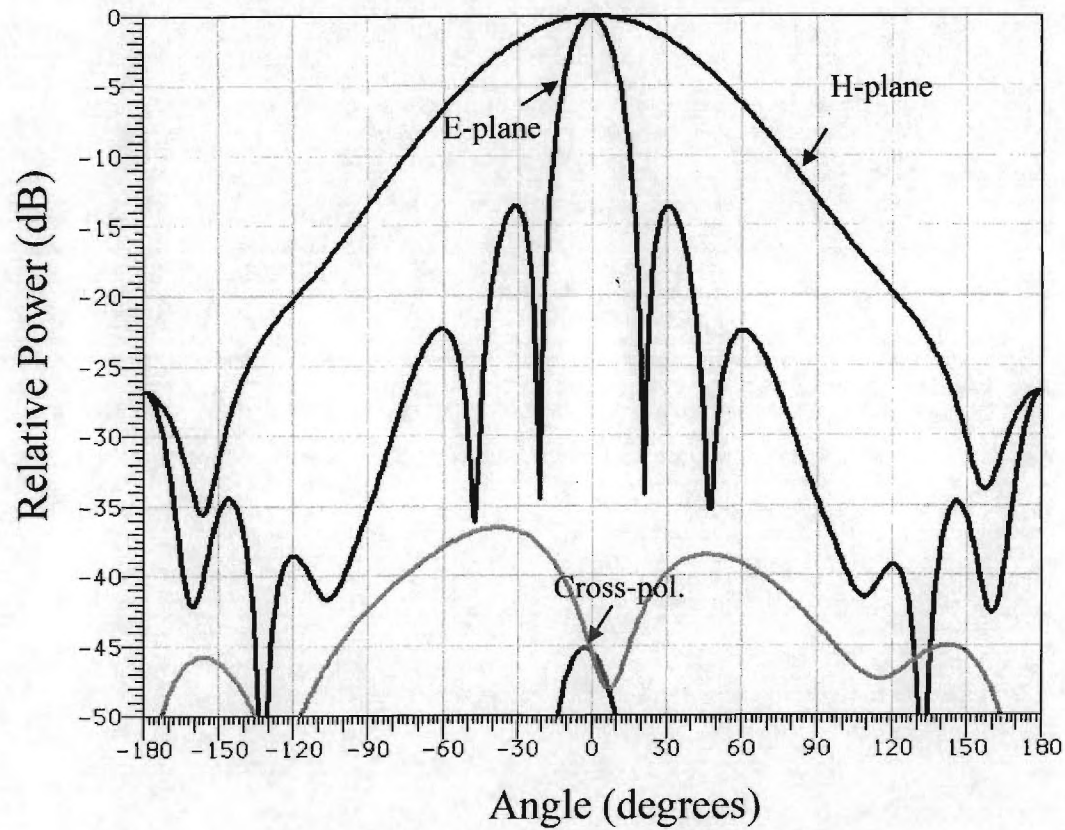

At 1.7 GHz  
(Directivity=13.8 dBi)



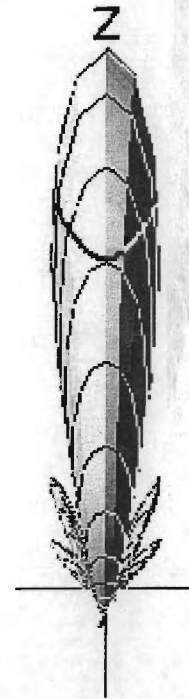
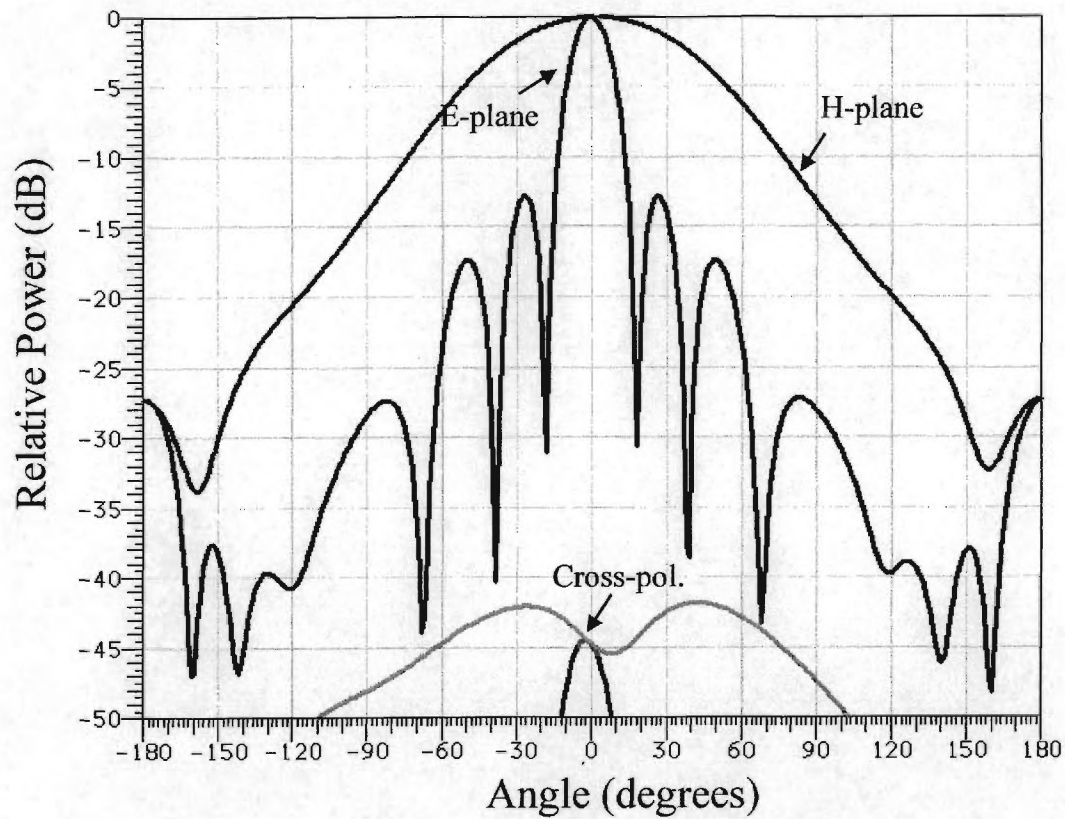

At 2.1 GHz  
(Directivity=14.3 dBi)

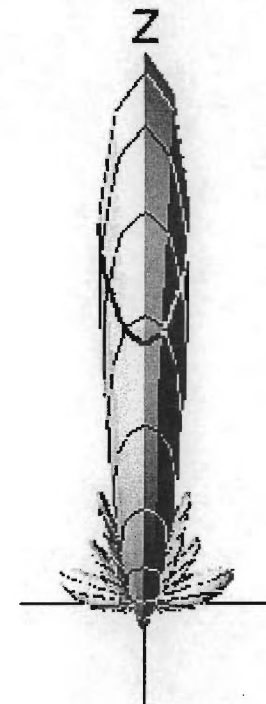
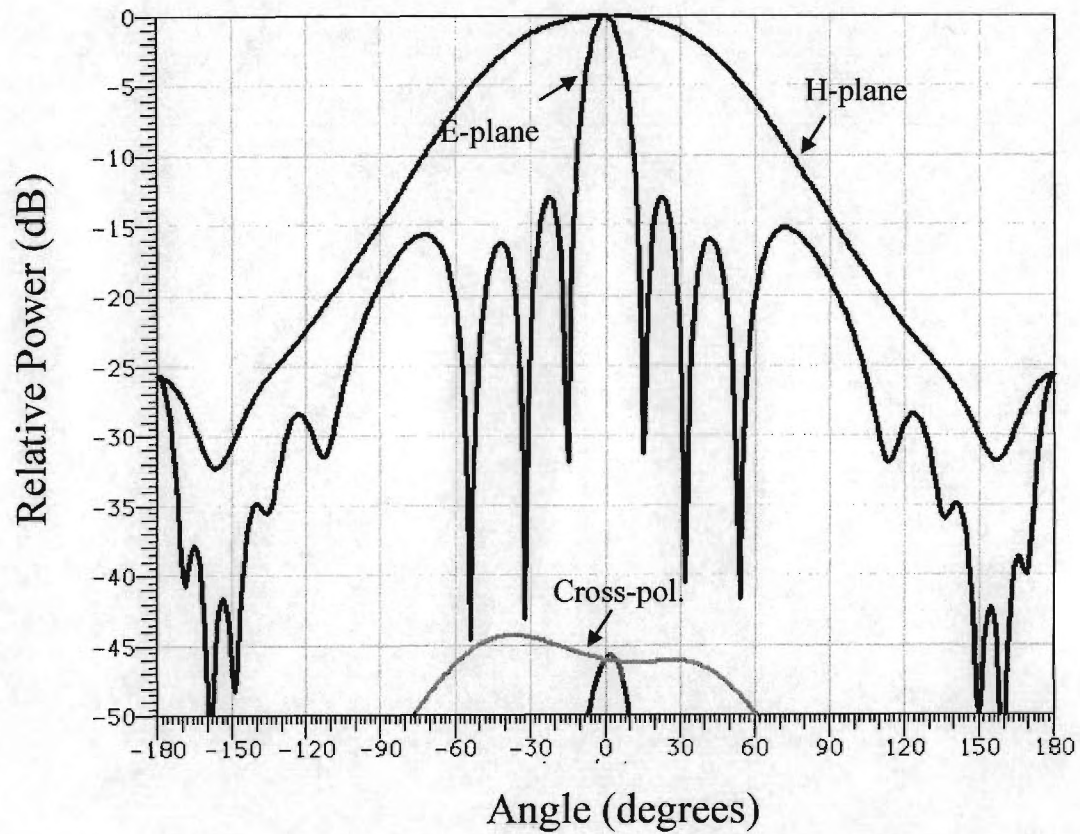

At 2.5 GHz  
(Directivity=14.5 dBi)

# Result of the fabricated Antenna Array

# Antenna Element

- Prototype

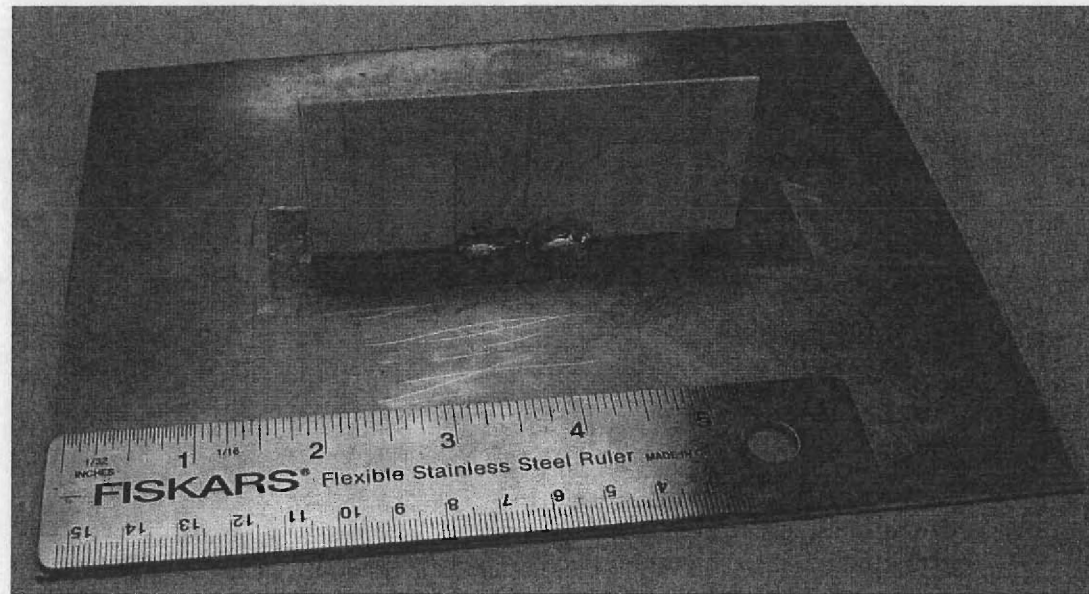

# Antenna Element

- Measured return loss

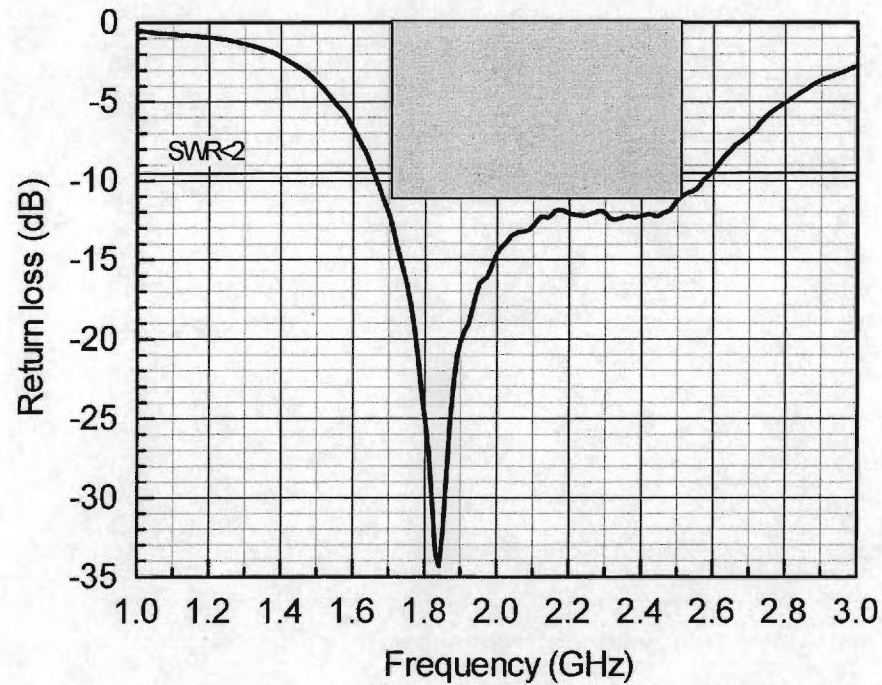

Design Frequency: 1.71-2.5 GHz

# Antenna Element

- Radiation patterns (to be measured)

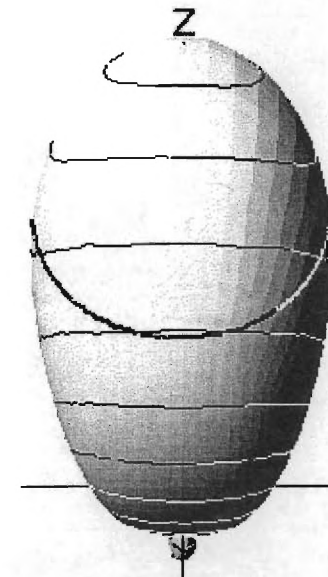
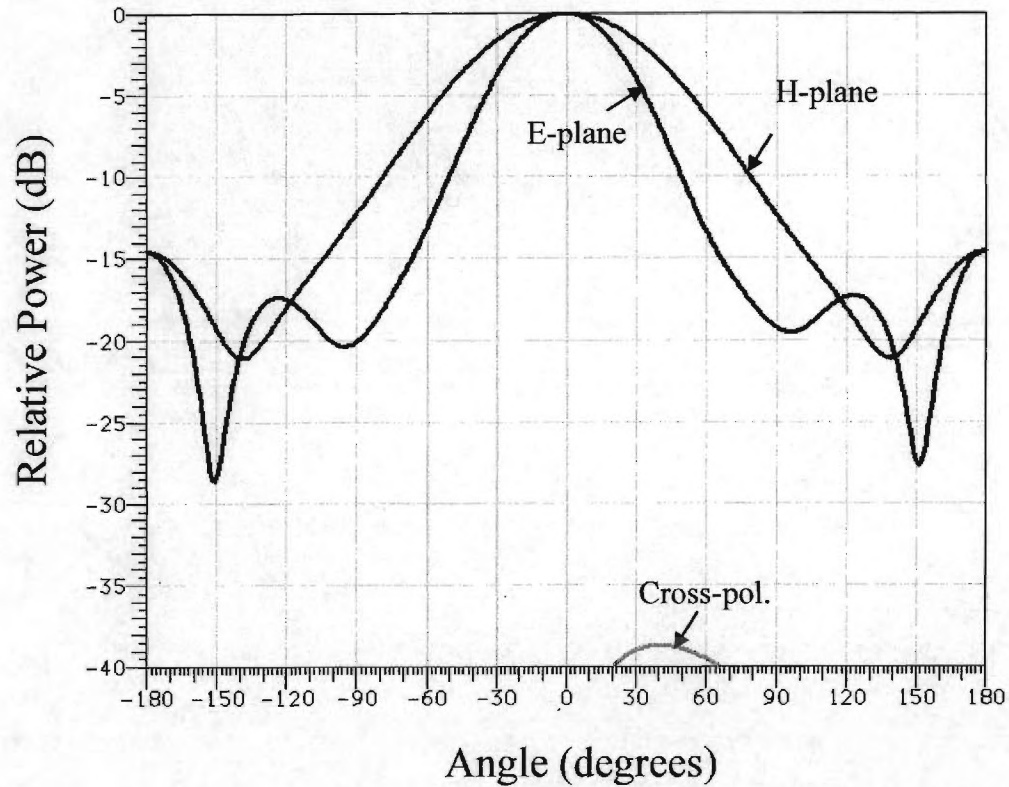

At 1.7 GHz



# Antenna Element

- Radiation patterns (to be measured)

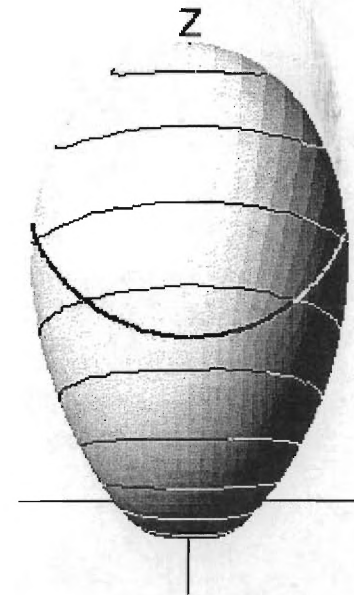
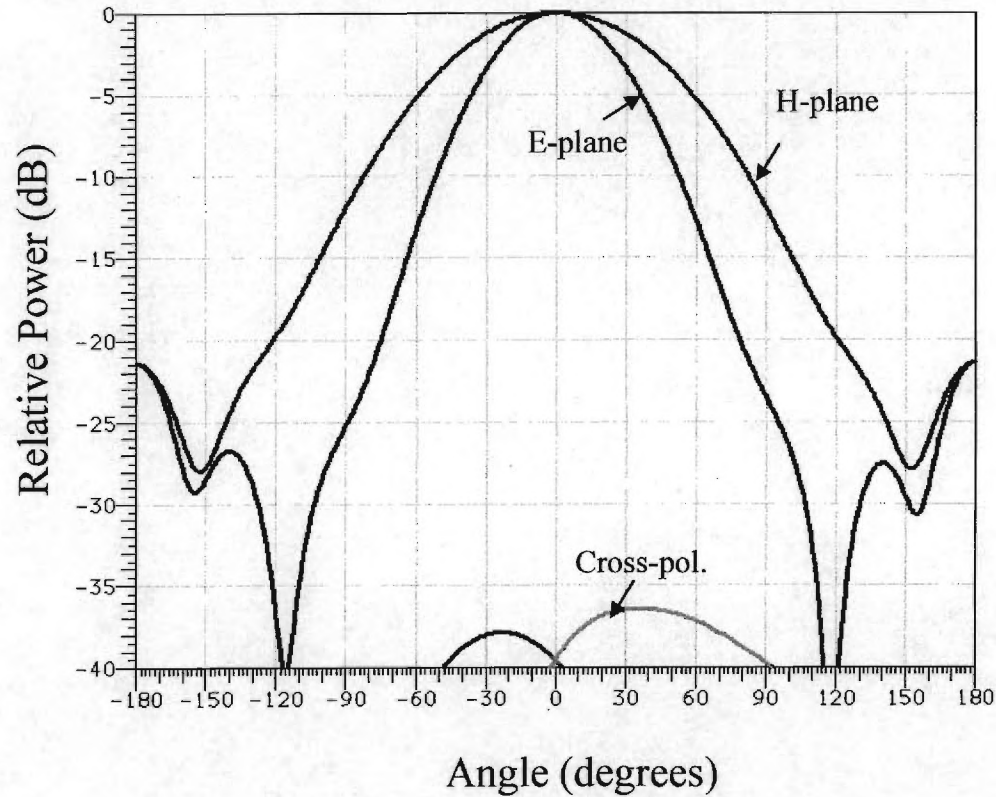

At 2.1 GHz

# Antenna Element

- Radiation patterns (to be measured)

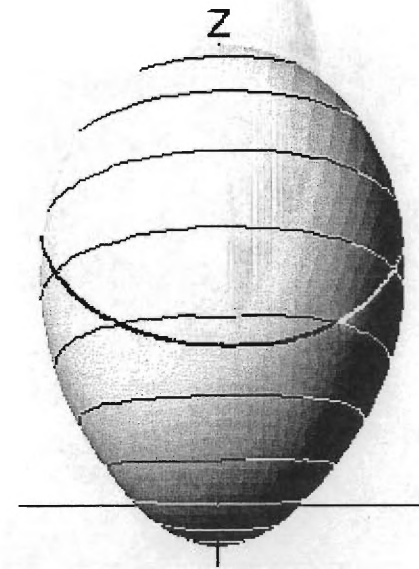
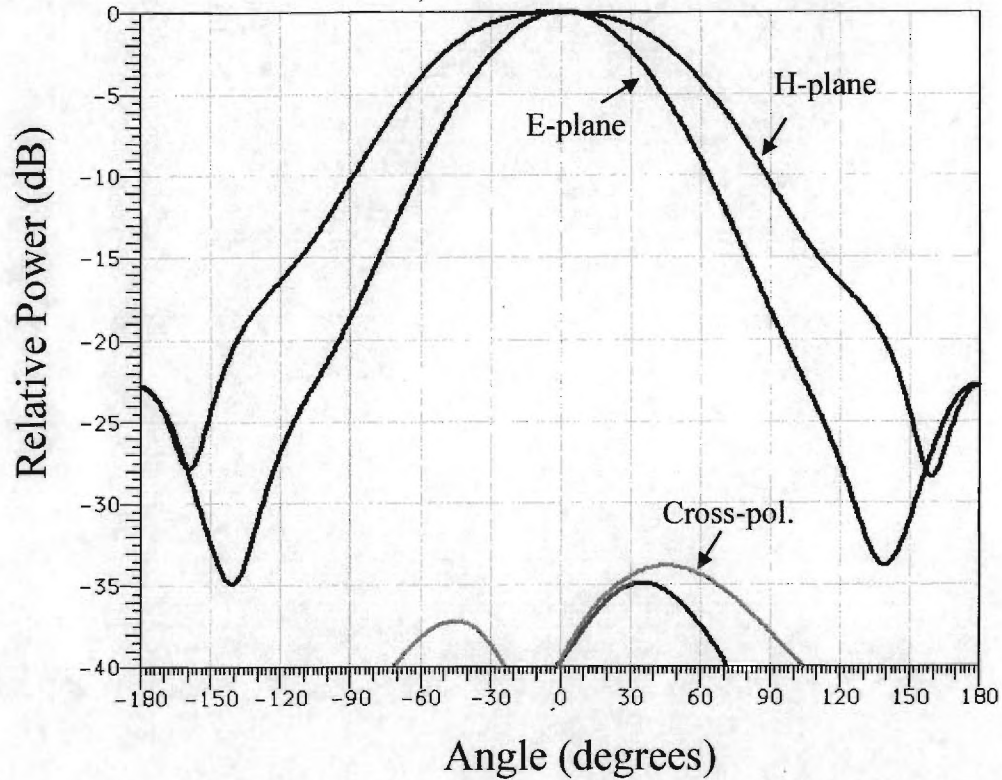

At 2.1 GHz



# 1×8-Element Antenna Array

- Prototype

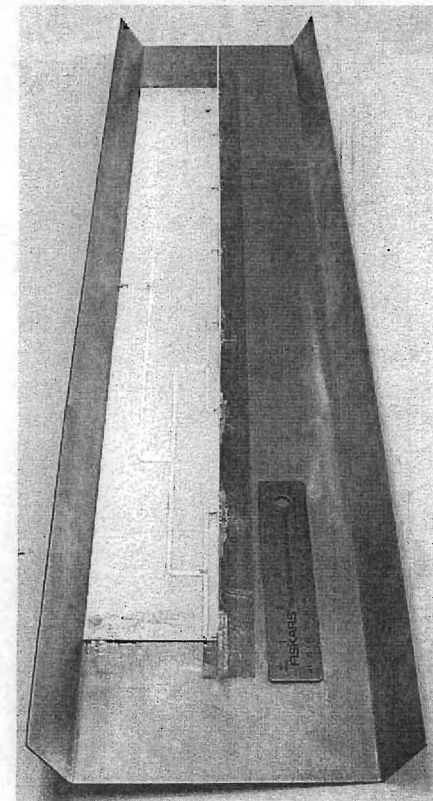
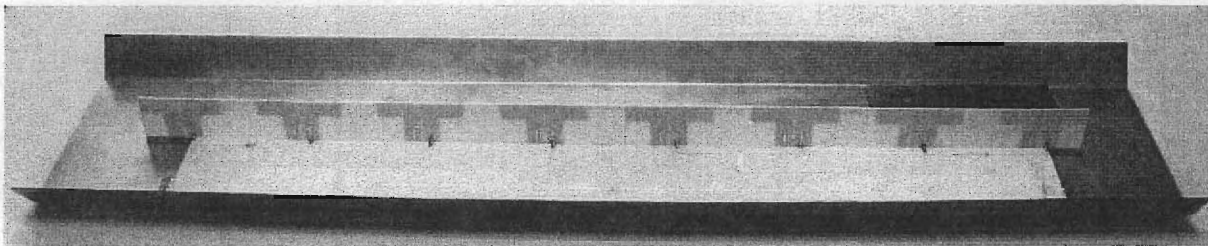
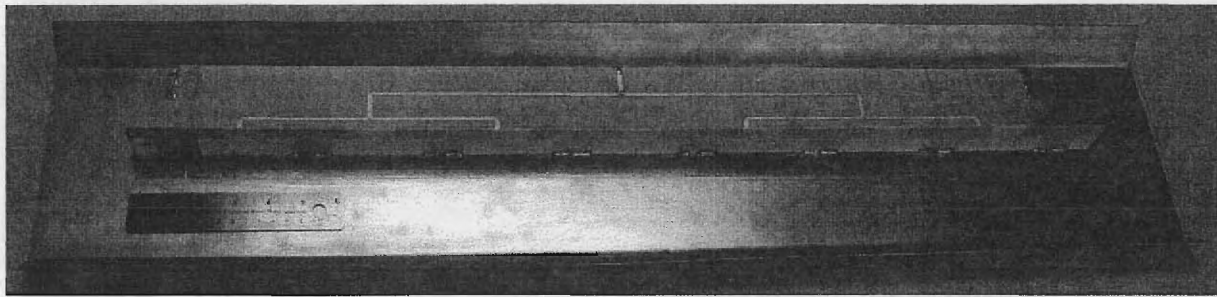

# 1×8-Element Antenna Array

- Measured return loss

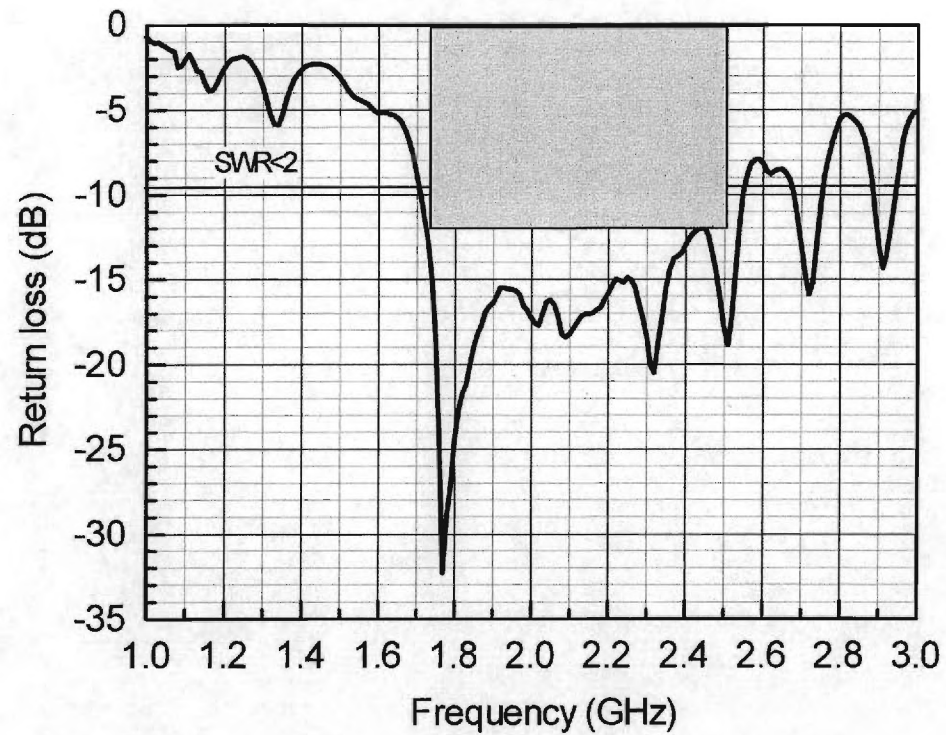

Design Frequency: 1.71-2.5 GHz

# 1×8-Element Antenna Array

- Radiation patterns (to be measured)

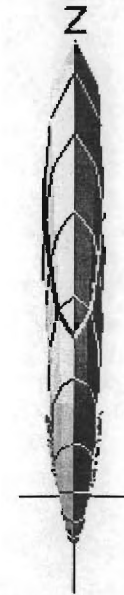
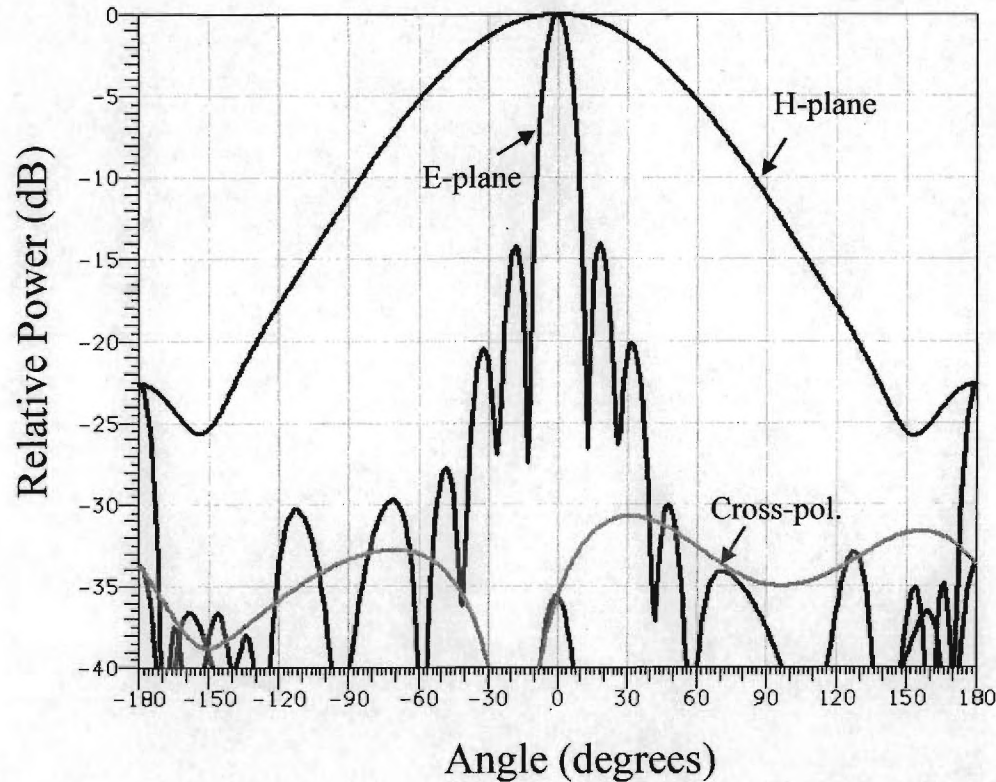

At 1.7 GHz

# 1×8-Element Antenna Array

- Radiation patterns (to be measured)

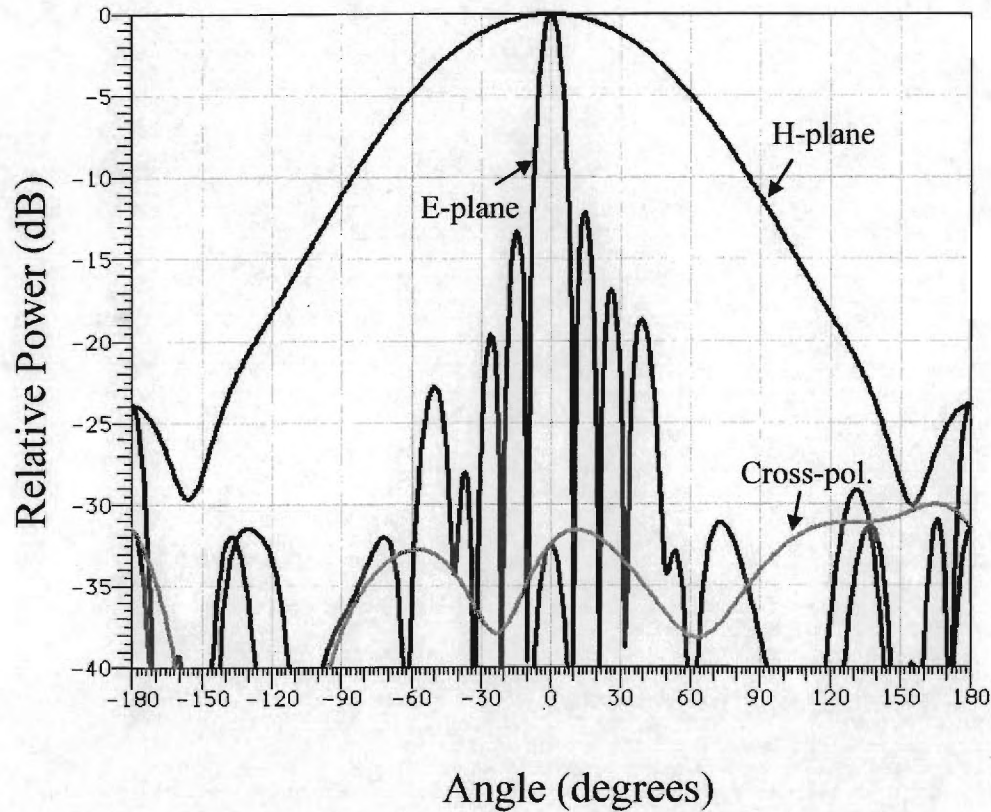

At 2.1 GHz

# 1×8-Element Antenna Array

- Radiation patterns (to be measured)

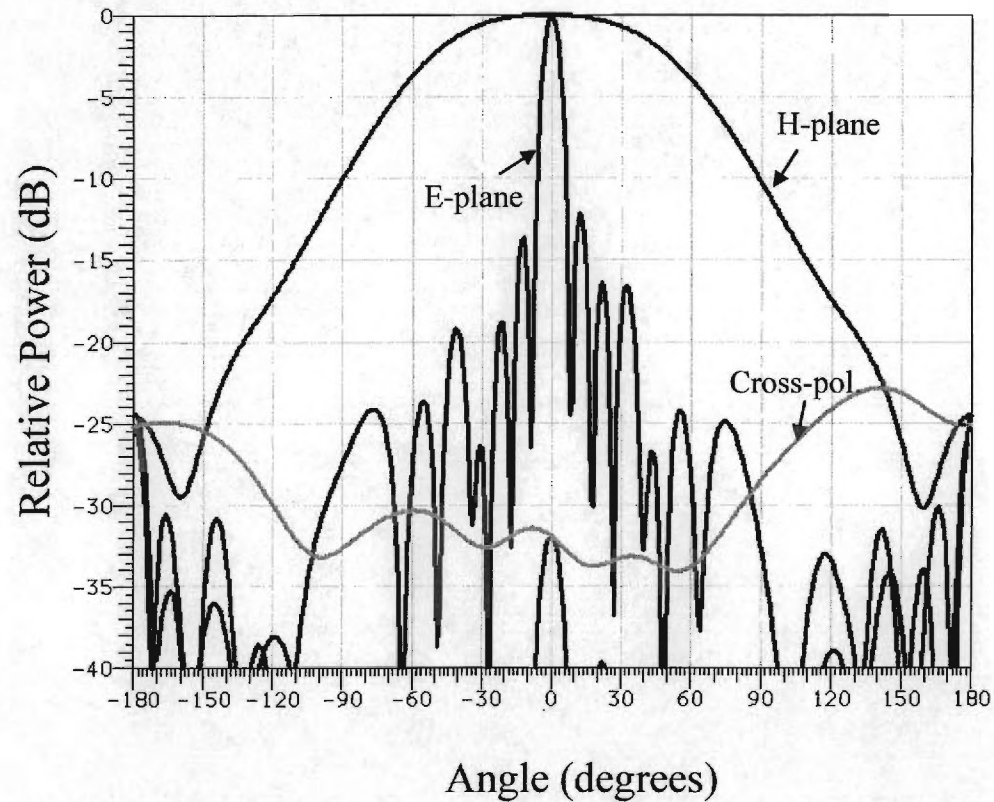

At 2.5 GHz

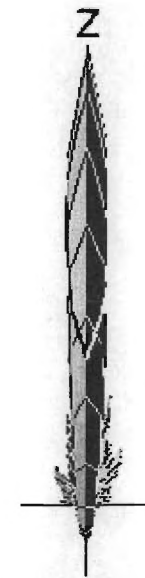



# 2×4-Element Antenna Array

- Prototype

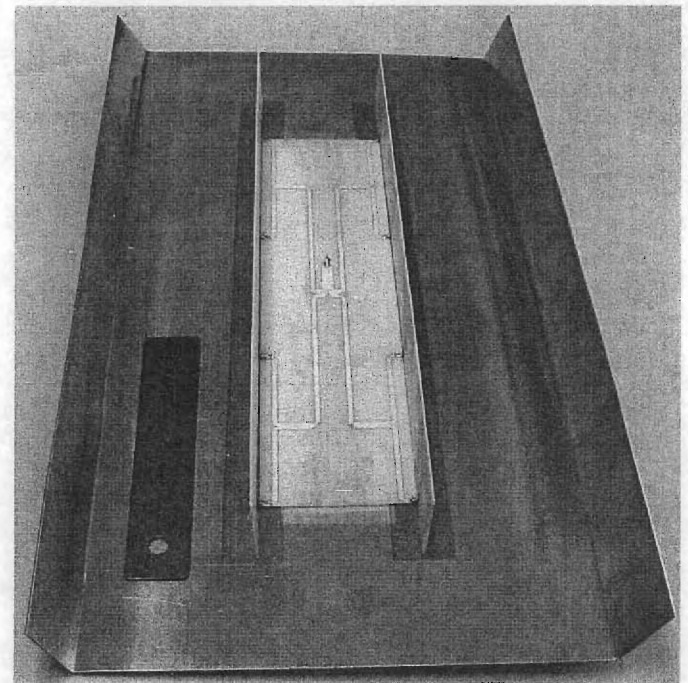
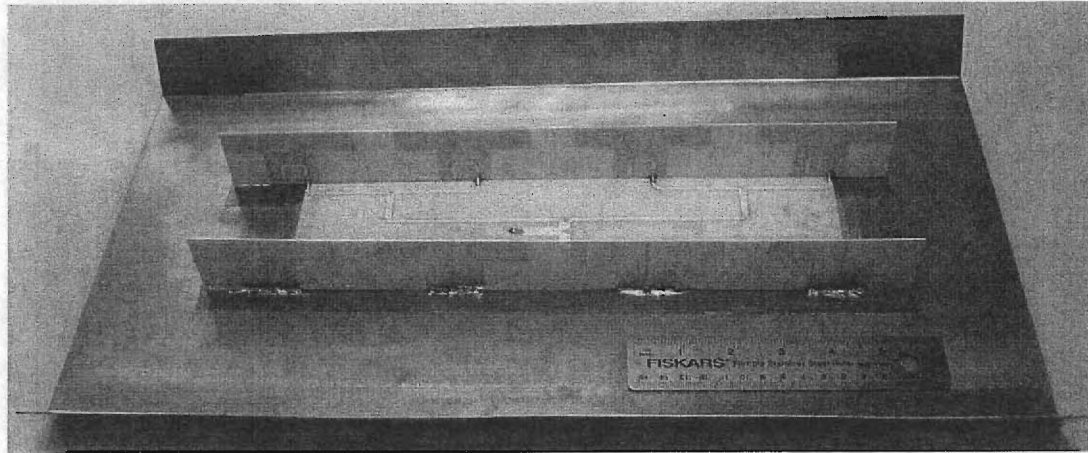

# 2×4-Element Antenna Array

- Measured return loss

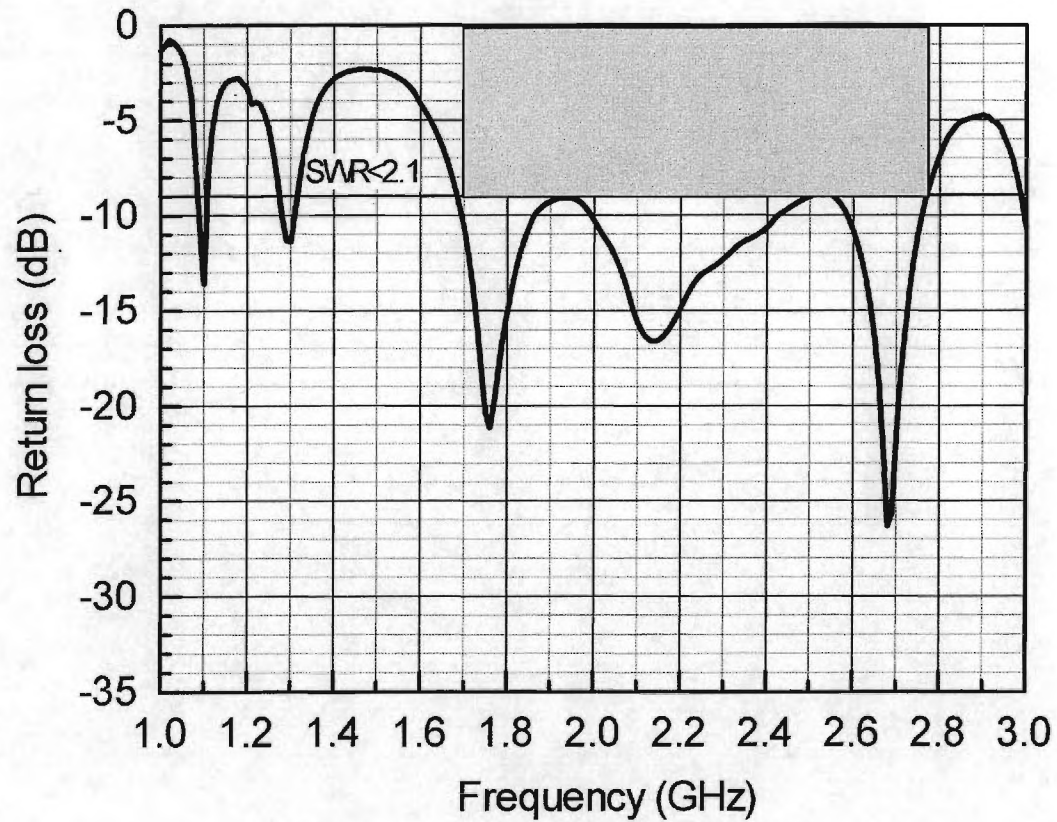

Design Frequency: 1.71-2.5 GHz

# 2×4-Element Antenna Array

- Radiation patterns (to be measured)

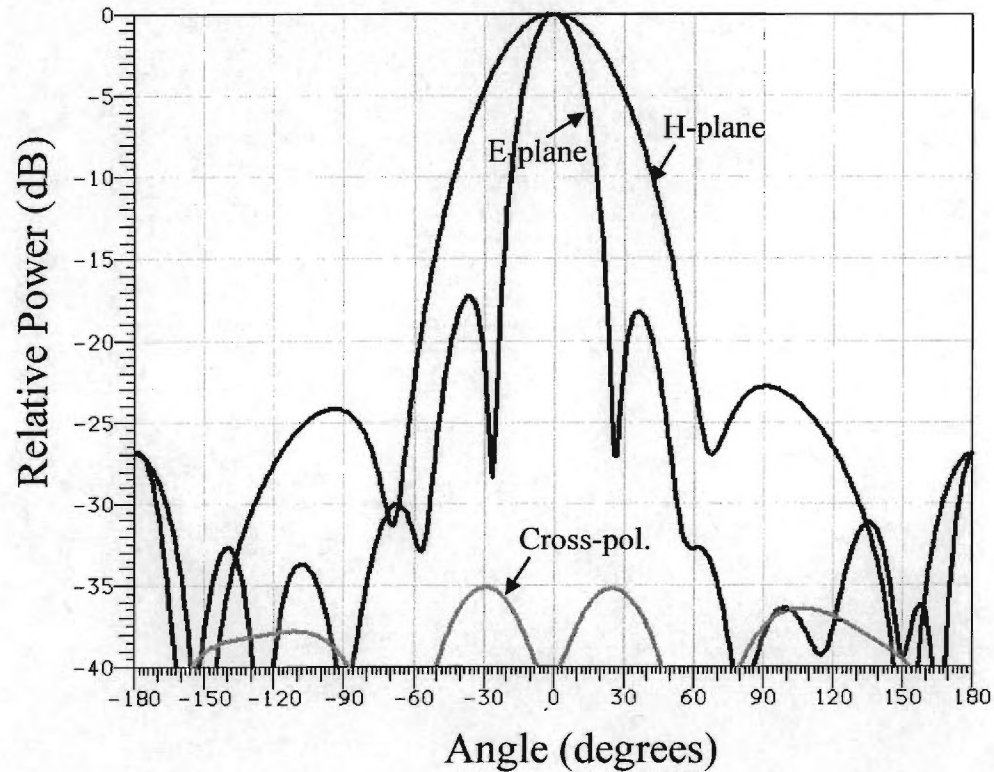

At 1.7 GHz

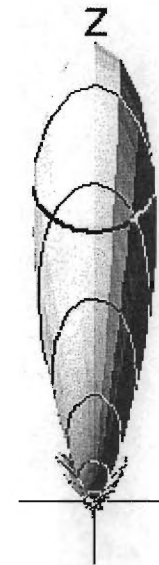



# 2×4-Element Antenna Array

- Radiation patterns (to be measured)

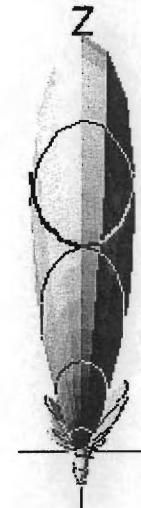
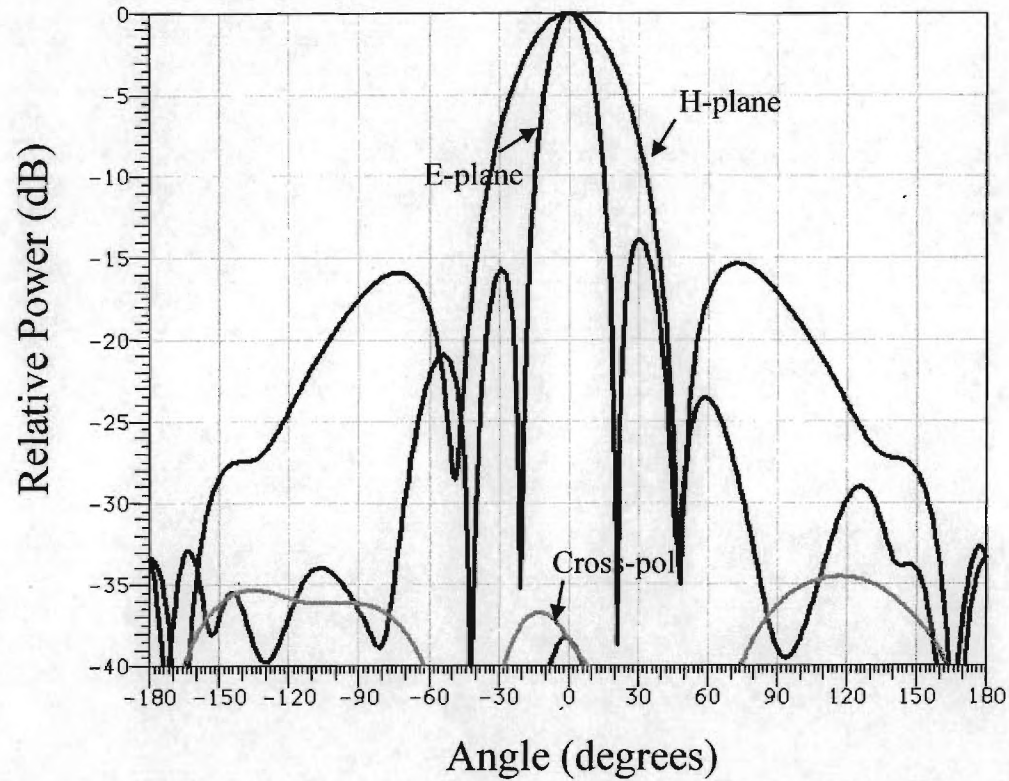

At 2.1 GHz

# 2×4-Element Antenna Array

- Radiation patterns (to be measured)

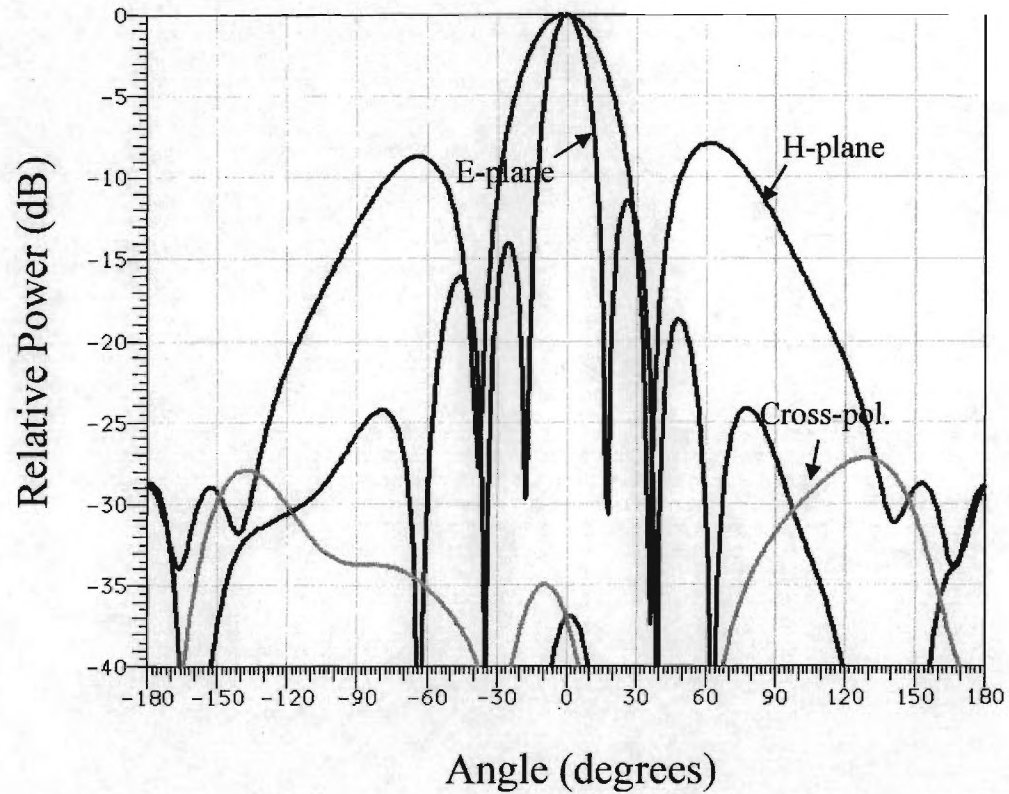

At 2.5 GHz