

GEORGIA INSTITUTE OF TECHNOLOGY  
OFFICE OF CONTRACT ADMINISTRATION  
SPONSORED PROJECT INITIATION

9c

Date: April 14, 1977

Project Title: *Research Initiation - Strengthening of Reinforced Concrete Columns for Earthquake Resistance*

Project No: *E-20-613*

Project Director: *Dr. Lawrence F. Kahn*

Sponsor: *National Science Foundation*

Agreement Period: From 4/1/77 Until 3/31/79  
(18-month budget period plus 6-month flexibility period)

Type Agreement:  
Grant No. *ENG77-06478*

Amount:  
*\$20,000 NSF*  
*12,634 GIT (E-20-345)*  
*\$32,634*

Reports Required:  
*Annual Letter Technical; Final Technical Report; Summary of Completed Project*

Sponsor Contact Person (s):

Technical Matters

Contractual Matters  
(thru OCA)

*Mr. James L. Bostick*  
*Grants Officer*  
*National Science Foundation*  
*Washington, D. C. 20550*

Defense Priority Rating: *none*

Assigned to: *Civil Engineering* (School/Laboratory)

COPIES TO:

Project Director  
Division Chief (EES)  
School/Laboratory Director  
Dean/Director-EES  
Accounting Office  
Procurement Office  
Security Coordinator (OCA)  
Reports Coordinator (OCA)

Library, Technical Reports Section  
Office of Computing Services  
Director, Physical Plant  
EES Information Office  
Project File (OCA)  
Project Code (GTRI)  
Other \_\_\_\_\_

8-17-81

GEORGIA INSTITUTE OF TECHNOLOGY  
OFFICE OF CONTRACT ADMINISTRATION  
SPONSORED PROJECT TERMINATION

Date: 4/24/81

Project Title: Research Initiation - Strengthening of Reinforced Concrete Col  
for Earthquake Resistance

Project No: E-20-613

Project Director: Dr. L. F. Kahn

Sponsor: NSF

Effective Termination Date: 3/31/79

Clearance of Accounting Charges: 3/31/79

Grant/Contract Closeout Actions Remaining:

- Final Invoice and Closing Documents
- Final Fiscal ~~Report~~ Accounting
- Final Report of Inventions
- Govt. Property Inventory & Related Certificate
- Classified Material Certificate
- Other \_\_\_\_\_



Assigned to: Civil Engineering (School/~~Laboratory~~)

COPIES TO:

- Project Director
- Division Chief (EES)
- School/Laboratory Director
- Dean/Director-EES
- Accounting Office
- Procurement Office
- Security Coordinator (OCA)
- ~~Reports Coordinator (OCA)~~

- Library, Technical Reports Section
- EES Information Office
- Project File (OCA)
- Project Code (GTRI)
- Other \_\_\_\_\_

E 20-

Annual Report Project ENG 77-06478  
Research Initiation - Strengthening of Reinforced Concrete  
Columns for Earthquake Resistance

I. Summary

Approximately sixty percent of the research has been completed on the project entitled "Research Initiation - Strengthening of Reinforced Concrete Columns for Earthquake Resistance." Six reinforced concrete columns have been designed and constructed. The full size columns measure 10-in. by 10-in. by 11 ft. long and are reinforced with four No 7 reinforcing bars. The bars have all been instrumented with electrical resistance strain gages. Various strengthening techniques have been designed and are ready for application to four columns.

A major structural steel frame was designed and constructed for testing the columns. The frame permits simultaneous axial and transverse loading of the columns. Auxiliary brackets and other testing fixtures are being fabricated.

Both concrete and steel material samples have been tested. The nominal concrete compressive strength is 6400 psi while the nominal yield strength of the steel reinforcement is 58,200 psi.

Current literature dealing with repair and strengthening of structures has been reviewed and specific topics dealing with strengthening of columns were discussed at the NSF sponsored workshop on Repair, Rehabilitation and Strengthening of Structures.

II. Research Activity and Results

Objective

The objective of this research program is the experimental investigation of several methods of strengthening existing reinforced concrete columns for

improved earthquake resistance. To accomplish this objective over the past year, the following research has been conducted.

#### Literature Review

Recently published literature concerning repair and strengthening of structures has been reviewed. The most significant technical papers were those contained in Volume VII of the Preprints of the Sixth World Conference on Earthquake Engineering, Repair and Strengthening of Structures.

#### Construction of Test Specimens

Six reinforced concrete column specimens have been constructed. These identical columns model an existing, unstrengthened column; the details of the models are shown in Figure 1. The reinforcement design of the six is identical with 4 longitudinal No 7 bars and No 4 gage wire ties. The columns were designed without consideration of ductility or other seismic requirements as specified by Reference 1 or 2. In regions where earthquakes are not of major concern such as the Southeast, no special attention has been given to seismic requirements. Until recently, closely spaced ties required for ductility have not been used in column reinforcement. Because the objective of the project is to investigate existing columns, such ties were omitted from the design of the models.

Figure 2 shows the construction of the reinforcing cages. The heavily reinforced center section models a rigid joint between the column and a stiff floor system.

The connection between a building's "soft" first story and a rigid structure above has proven to be a critical location for earthquake resistance. The column models were designed to explore the weakness of the column below this joint. When the columns are loaded transversely, the column on each side of this stiff center section will respond as a first story column.



Figure 1. Column reinforcing bar design.

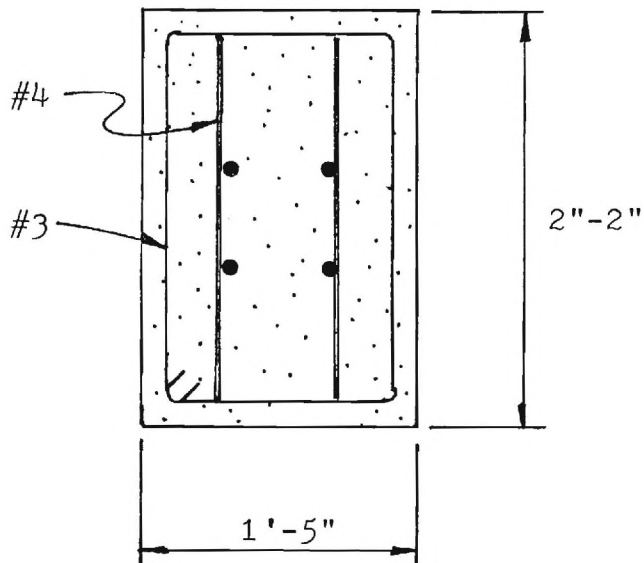
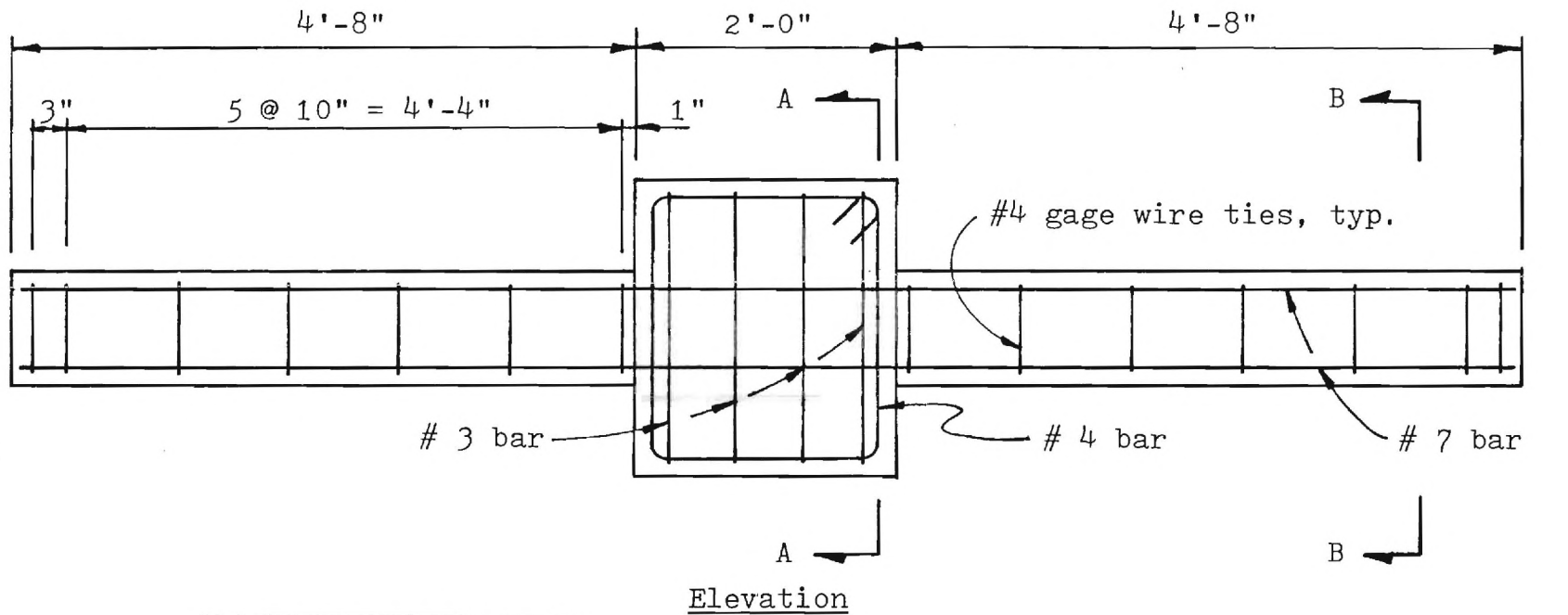

Section A-A

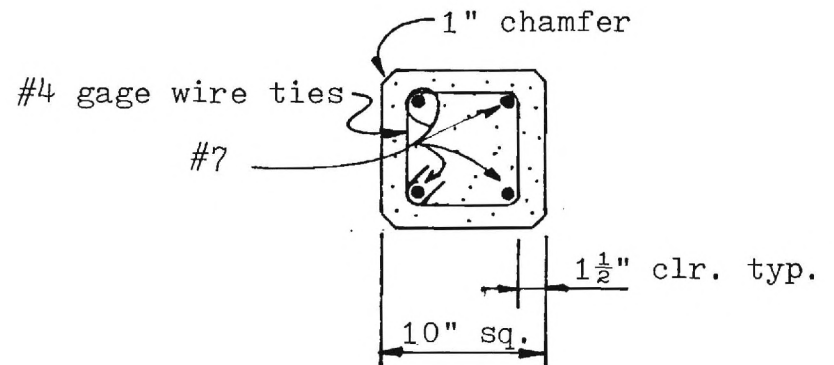

Section B-B

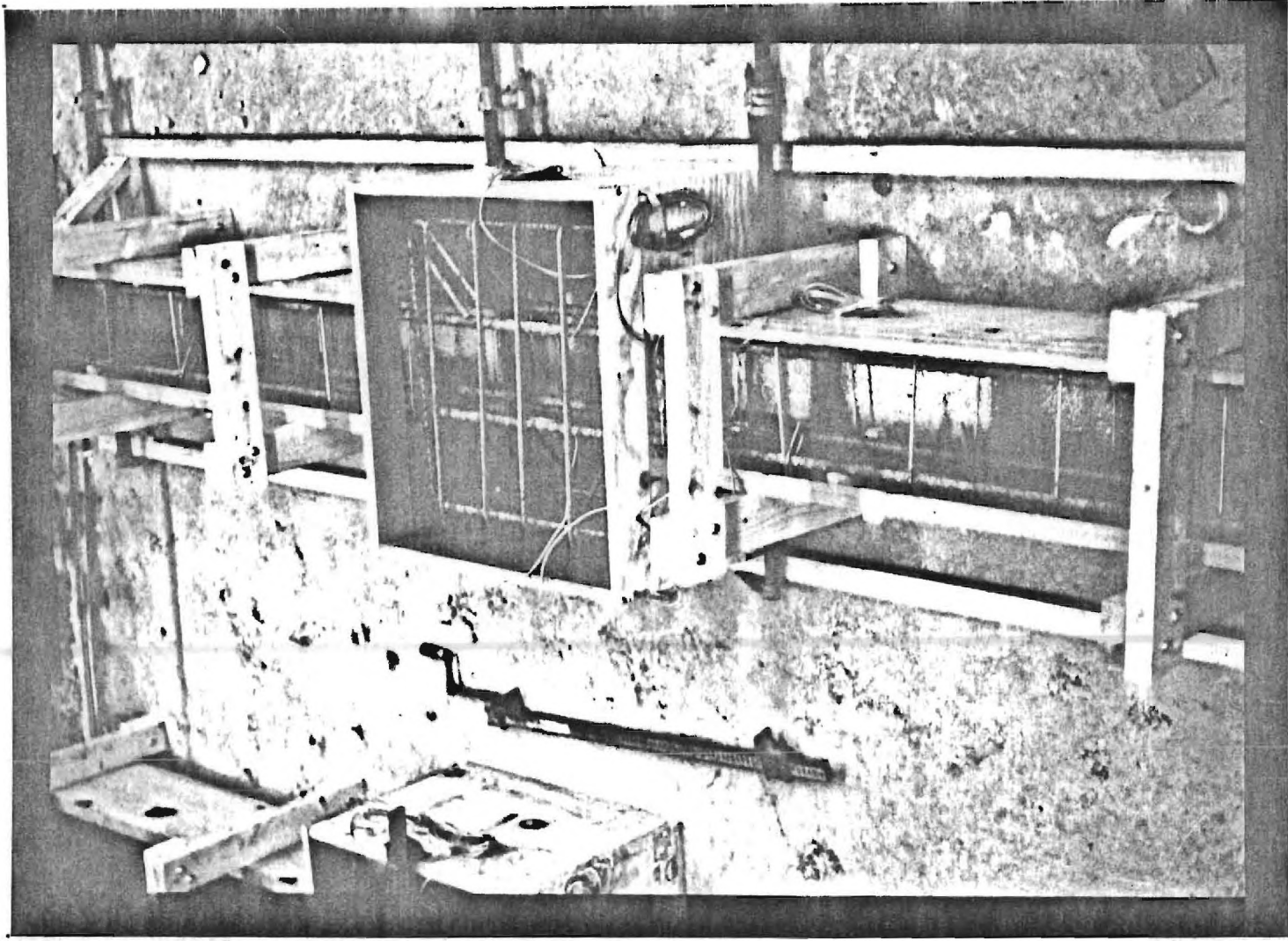

Figure 2. Reinforcing bar cage in column forms.

Before the cages were assembled, electrical resistance strain gages were applied to both the longitudinal and transverse reinforcement. This instrumentation will be used to determine initial yield level, to find the ductility of the columns relative to steel yielding, and to compare simple analytical predictions with actual behavior.

Three columns were cast simultaneously as shown in Figure 3. A standard, 3/4-inch maximum size aggregate 4000 psi concrete was ordered from a local producer, and it was delivered to the Georgia Tech laboratory in a ready-mix truck. After making a slump test, the concrete was shoveled into the column forms and was consolidated using a spud vibrator.

The forms were placed horizontally rather than vertically for ease of casting. It is important to note that construction joints on each side of the rigid center section were eliminated by this casting procedure. Based on findings by Lee (3), the absence of these joints is believed to be insignificant.

The columns were cured under wet burlap for seven days at temperatures ranging between about 40°F to 70°F. The forms were stripped on the seventh day, and the burlap removed. The columns were then exposed to room temperature and humidity conditions. Figure 4 shows the six columns.

#### Material Samples

Standard test cylinders cast with the columns were used to determine both the 28-day compressive strength ( $f'_c$ ) and the split-cylinder tensile strength ( $f_t$ ).

Six 6x12 cylinders from each pour were fog cured for 28 days. Three cylinders were used for the compression tests, and three for the split-cylinder test. The stress-strain curve was determined for each of the compressive cylinders, and the average secant modulus ( $E_c$ ) was determined.



Figure 3. Casting columns in horizontal position with ready-mix concrete.

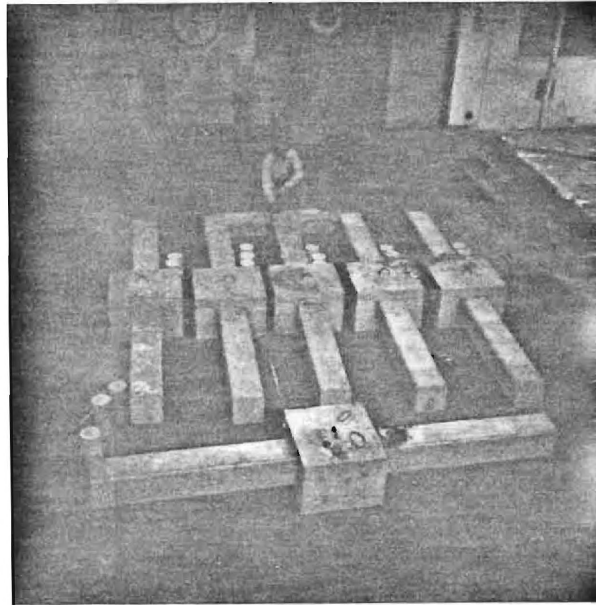

Figure 4. Six model columns ready for strengthening procedures

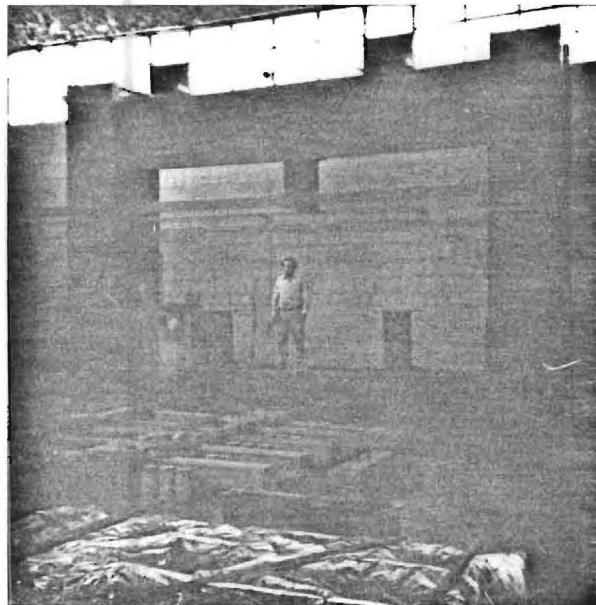

Figure 5. Structural steel test frame.

All cylinder tests conformed to ASTM Standards. The values for the concrete properties are shown in Table 1.

An additional three 6x12 cylinders were cast along with each column. These cylinders have undergone the identical curing procedure as the matching column; the cylinders will be compression tested when the columns are tested.

Table 1

Column numbers	$f'_c$ (psi)	$f_t$ (psi)	$E_c$ ( $\times 10^6$ psi)
1, 2, 3	6350	490	2.7
4, 5, 6	6470	440	2.3

#### Test Frame

The structural steel frame shown in Figure 5 was erected for testing the columns. The frame is made of W36x150 sections connected with A325 bolts. This construction was accomplished within budget. The steel sections were donated by the Georgia Department of Transportation, and some of the fabrication was donated by Owen of Georgia, Steel Fabricators. The frame permits simultaneous axial and transverse loading of the model columns.

#### References

1. American Concrete Institute, Building Code Requirements for Reinforced Concrete (ACI 318-71), American Concrete Institute, Detroit, Michigan 1971
2. Seismology Committee, Structural Engineers Association of California, Recommended Lateral Force Requirements and Commentary, 1975, Structural Engineers Association of California, San Francisco, California 1976
3. Lee, D. L. N., "Original and Repaired Reinforced Concrete Beam-Column Subassemblages Subjected to Earthquake Type Loading," UMEE 76R4, The University of Michigan, Department of Civil Engineering, Ann Arbor, MI 1976



### III. Significant Research Accomplished

The following research tasks have been accomplished:

1. The six basic reinforced concrete model columns have been designed, constructed, and strain gaged;
2. The column strengthening techniques have been designed;
3. The structural steel test frame has been designed and constructed;
4. The recent literature dealing with repair and strengthening of structures has been reviewed.

These accomplished tasks permit strengthening and testing of the models during the next two months, followed by data evaluation and reporting.

### IV. Personnel Supported

Three persons have worked on this NSF project, ENG 77-06478; they are Lawrence Kahn, Benjamin Suriano and William Bynum. The last was not supported by NSF funds. Following are descriptions of the work contributed by each:

Lawrence Kahn

Dr. Kahn has served as project director and as principal investigator. As such he has organized and supervised the project. Initially he reviewed the latest literature on repair and strengthening, and he attended a workshop on repair and strengthening where he discussed significant problems related to ductility and strengthening of columns.

He designed the model columns and corresponding strengthening techniques, detailed the forms for the columns, and determined strain gage patterns. After purchasing necessary materials he showed the research assistants how to build the forms, to fabricate the reinforcing bar gages and to place strain gages on the reinforcement. He worked with the assistants in all these tasks. Dr. Kahn helped to cast the columns and to test all concrete and steel samples.

Dr. Kahn designed the structural steel test frame, solicited appropriate "donations" from the Georgia Department of Transportation and from Owen of Georgia, Steel Fabricators, and he contracted for and supervised erection of the test frame. He has designed and is supervising construction of the loading system for the columns.

Benjamin Suriano

Mr. Benjamin Suriano is a graduate student at Georgia Tech and is working as a research assistant, being supported one-third time by this project (\$1000 per quarter). He has helped construct the model columns and has aided in testing samples of the concrete and steel reinforcement. This project is serving as a basis for Mr. Suriano's masters degree thesis.

William Bynum

Mr. William Bynum is a graduate student at Georgia Tech, and he is supported as a one-third time research assistant by the State of Georgia. He has been principally responsible for strain gaging the steel reinforcing bars. He has aided in building the reinforcing bar cages, casting the columns, and testing samples of steel reinforcement.

#### V. Technical Papers

No technical papers concerning this project have been published or currently are under preparation. Several papers will be written at the conclusion of the project.

A technical presentation, including preprint, is under preparation for the Fifth National Meeting of the Universities Council for Earthquake Engineering Research, to be held at the Massachusetts Institute of Technology, June 1978.

## VI. Related Events

Dr. Kahn attended the NSF sponsored workshop entitled "Repair, Strengthening and Rehabilitation of Buildings", which was held in South San Francisco, June 9-10, 1977. He presented a talk on infilled walls for earthquake strengthening, and he acted as a secretary for a working group concerned with the evaluation of existing construction and materials for rehabilitation and repair. While in attendance he discussed the current research project and strengthening of columns in general with many workshop participants, including Professors Bertero, Bresler, Hanson, Sozen and Wight and Messrs. Fiorato, Freeman, Kariotis and Warner.

Dr. Kahn has made an informal presentation concerning this project and earthquake engineering to the Georgia Section of the American Concrete Institute. Further Dr. Kahn has used information gained through conducting this research project for lectures in a graduate level course, Advanced Reinforced Concrete.

E-20-6.

FINAL PROJECT REPORT  
NSF FORM 98A

PLEASE READ INSTRUCTIONS ON REVERSE BEFORE COMPLETING

PART I-PROJECT IDENTIFICATION INFORMATION

1. Institution and Address Georgia Inst. of Technology Atlanta, Georgia 30332	2. NSF Program Structural, Mat'ls, and Geotech. Engrg.	3. NSF Award Number ENG77-06478
	4. Award Period From 4/1/77 To 3/31/79	5. Cumulative Award Amount \$20,000

6. Project Title  
Research Initiation --  
Strengthening of Reinforced Concrete Columns for Earthquake Resistance

PART II-SUMMARY OF COMPLETED PROJECT (FOR PUBLIC USE)

Four identical, 10-inch square, reinforced concrete columns were constructed using four No. 7 bars and 6400 psi concrete. Their design included no special transverse reinforcement for earthquake resistance. Three of the columns were strengthened externally using various techniques in order to improve their shear resistance and ductility. One technique used 2-inch wide steel packaging bands which were wrapped around the column and spaced at 4-inch on center. The space beneath the bands was packed with grout. A second column was spirally wound with a 1/4-inch diameter steel bar on a 1.1-inch pitch. The space beneath the rectangular spiral was grouted. For the third strengthening technique, U-shaped clamps were fabricated from 2-inch x 5/16-inch steel bar and from 3 x 5 x 5/16 inch steel angle. Two U-clamps were bolted together around the column to form a hoop; these hoops were 4.25-inches on center.

All four columns were tested under static reversed cycle deflections of increasing magnitude and with a constant axial load of 80,000 lbs. The unstrengthened column collapsed when the lateral deflection was about twice the deflection causing yield of the tension steel. The three strengthened columns responded nearly identically and resisted three reversed cycles at four times the yield deflection with little deterioration. Based on the test results and the ease of construction, it was concluded that the U-clamp and banding techniques showed great promise in providing low cost, easy-to-construct methods for greatly improving the ductility and earthquake resistance of existing reinforced concrete columns.

PART III-TECHNICAL INFORMATION (FOR PROGRAM MANAGEMENT USES)

1. ITEM (Check appropriate blocks)	NONE	ATTACHED	PREVIOUSLY FURNISHED	TO BE FURNISHED SEPARATELY TO PROGRAM	
				Check (✓)	Approx. Date
a. Abstracts of Theses	XX				
b. Publication Citations	XX				
c. Data on Scientific Collaborators	XX				
d. Information on Inventions	XX				
e. Technical Description of Project and Results	XX	XX			
f. Other (specify)					
2. Principal Investigator/Project Director Name (Typed) Lawrence F. Kahn	3. Principal Investigator/Project Director Signature			4. Date 6-15-79	

F 20-61

Final Report

STRENGTHENING OF REINFORCED CONCRETE COLUMNS  
FOR EARTHQUAKE RESISTANCE

by

Lawrence F. Kahn

Prepared for

National Science Foundation  
Washington, D.C. 20550  
under  
Research Initiation Grant No. ENG77-06478

June 1979

Georgia Institute of Technology  
School of Civil Engineering  
Atlanta, Georgia 30332

Report NSF ENG77-06478

STRENGTHENING OF REINFORCED CONCRETE COLUMNS  
FOR EARTHQUAKE RESISTANCE

Lawrence F. Kahn  
School of Civil Engineering  
Georgia Institute of Technology  
Atlanta, Georgia 30332

June 1979

Final Report

Prepared for

National Science Foundation  
Division of Problem-Focused Research Applications  
Washington, D.C. 20550



## ABSTRACT

Four identical, 10-inch square, reinforced concrete columns were constructed using four No. 7 bars and 6400 psi concrete. Their design included no special transverse reinforcement for earthquake resistance. Three of the columns were strengthened externally using various techniques in order to improve their shear resistance and ductility. One technique used 2-inch wide steel packaging bands which were wrapped around the column and spaced at 4-inch on center. The space beneath the bands was packed with grout. A second column was spirally wound with a 1/4-inch diameter steel bar on a 1.1-inch pitch. The space beneath the rectangular spiral was grouted. For the third strengthening technique, U-shaped clamps were fabricated from 2-inch x 5/16-inch steel bar and from 3 x 5 x 5/16 inch steel angle. Two U-clamps were bolted together around the column to form a hoop; these hoops were 4.25-inches on center.

All four columns were tested under static reversed cycle deflections of increasing magnitude and with a constant axial load of 80,000 lbs. The unstrengthened column collapsed when the lateral deflection was about twice the deflection causing yield of the tension steel. The three strengthened columns responded nearly identically and resisted three reversed cycles at four times the yield deflection with little deterioration. Based on the test results and the ease of construction, it was concluded that the U-clamp and banding techniques showed great promise in providing low cost, easy-to-construct methods for greatly improving the ductility and earthquake resistance of existing reinforced concrete columns.

## ACKNOWLEDGEMENTS

Financial support was provided by the National Science Foundation, Research Initiation Grant ENG77-06478, and by the Georgia Institute of Technology. This support gratefully is acknowledged.

The main steel members for the structural test frame were provided by the Georgia Department of Transportation through the good offices of Mr. Vernon Smith. All structural steel fabrication and miscellaneous steel was donated by Owen of Georgia, Steel Fabricators, with the generous assistance of Messrs. Hank Cobleigh and Robert Heany.

Mr. Benjamin Suriano accomplished much of the experimentation, and he was aided by Mr. William Bynum and Ms. Loretta Britsch.

Opinions, findings and conclusions expressed herein are those of the author and do not reflect necessarily the views of the sponsors.

## TABLE OF CONTENTS

### ACKNOWLEDGEMENTS

CHAPTER	Page
1. INTRODUCTION	1
1.1 Purpose	1
1.2 Scope	1
1.3 Background	1
2. EXPERIMENT DESIGN	7
2.1 Design Philosophy	7
2.2 Specimen Design	9
2.3 Specimen Construction	9
2.4 Test Set-up and Instrumentation	21
2.5 Test Procedure	21
3. EXPERIMENTAL RESULTS	29
3.1 Load-Deflection Response	29
3.2 Physical Observations	35
3.3 Moment-Curvature Response	38
3.4 Strain Observations	45
3.5 Energy Dissipation	52
4. DISCUSSION	55
4.1 Quantitative Analysis	55
4.2 Qualitative Analysis	59
4.3 Limits of Findings	61
5. CONCLUSIONS AND RECOMMENDATIONS	63
APPENDIX: MATERIAL TESTS	65
REFERENCES	95

## 1. INTRODUCTION

### 1.1 Purpose

The purpose of this research was to experimentally investigate several methods of strengthening reinforced concrete columns to improve their seismic resistance.

Due to increasing alarm over the possible occurrence of earthquakes, some geographical sections of the United States and other parts of the world have considered modifying zoning criteria for earthquake resistant design. Furthermore, some facilities now are desired to survive and function after severe earthquakes. For these reasons, the designer must turn his attention to methods of strengthening existing structures. Ideally, these methods should be employed before an earthquake occurs; however, they can be used along with the repair of a previously damaged structure.

The objective of this research was to initiate investigations aimed at providing the designer with qualitative and quantitative information on how existing reinforced concrete columns may be economically strengthened.

### 1.2 Scope

The scope of this project was limited. Four identical reinforced concrete columns were cast and three exterior strengthening methods were employed. These strengthening methods were the only variables in the experimental program. They were used to provide additional shear capacity for the structural members when compared to an unstrengthened member and to provide confinement.

### 1.3 Background

The deterioration of strength of reinforced concrete columns due to earthquake type loading has been investigated by several researchers (4,7,9,11,13,19,20) and design recommendations have been proposed including that the minimum transverse reinforcement ratio be 0.6 percent and that the transverse reinforcement be designed to carry the full shear

forces. Other studies have investigated the adequacy of the repair of concrete structures after being damaged by earthquake type loading (5, 7,9,10,13,14).

Results from repaired specimens tend to show that the repaired structures respond with similar strength and in the same manner as the original specimen; although, significant differences can occur (13).

The joint ASCE-ACI Task Committee 426 (16) defined the basic mechanisms of shear transfer and failure criteria for reinforced concrete columns. The most prevalent mechanisms are shear transfer by concrete shear stress which occurs in uncracked members or portions of structural members, interface shear transfer which is stress along a diagonal tension crack and is called aggregate interlock, dowel shear which is shear resisted by longitudinal reinforcement, and shear reinforcement.

Under repeated and reversed loadings the Committee states that deterioration of the first three mechanisms will occur rapidly and that only by employing closely spaced stirrups will splitting along the longitudinal reinforcement be restrained. Therefore, dowel action and shear reinforcement will account for the full shear transfer. However, since dowel action is dependent on shear reinforcement, the stirrups should provide for the full shear in beams and columns.

Vallenas, Bertero, and Popov (19) investigated column cores confined by rectangular hoops and loaded axially. A total of 14 reinforced specimens were tested varying the effects of 3 parameters, concrete cover, lateral reinforcement, and longitudinal reinforcement.

The first group consisted of two plain 20 in. long by 10 in. square concrete columns which underwent a relatively brittle type of failure with a large diagonal crack opening suddenly.

The second group of six specimens tested were confined concrete columns with no longitudinal reinforcement, 3 with cover and 3 without. The confinement was obtained by using plain #7 wire at 1.33" c/c spacing. This lateral reinforcement did not rupture at failure, instead the hooked ends slipped out of the concrete showing a need to use deformed bars for better anchorage. The specimens with cover had a slight increase in maximum load before cracking than those without cover.

The third group of specimens tested were similar to the 2nd group, with the addition of 8 #6 longitudinal bars. As in the above group,

3 columns had cover and 3 did not. In both these cases an increase in concrete strength was obtained with failure occurring from buckling of the longitudinal reinforcement and rupture of the stirrups.

The confinement of the test specimens produced an increased strength of 13% when compared to the plain specimens. It was also noted that the Uniform Building code (UBC, 18) and American Concrete Institute (ACI-318-77,3) equations for ratio of confining steel can be combined and this equation can be used for any type of confinement system by varying the confinement effectiveness ratio for different types of confinement and materials.

Bertero and Popov (4) investigated the hysteric behavior of reinforced concrete beams subjected to high and low shear stresses. They suggested that this deteriorating behavior can be improved by using a closer spacing of stirrups and increasing the are of compression reinforcement.

Wight and Sozen (20) investigated the hysteric behavior of 12 reinforced concrete columns subjected to large shear reversals. The specimens represented a column between the points of contraflexure above and below a story level. The principal variables of the test were the amount of axial load, the transverse reinforcement ratio, and the required deflection ductility (total deflection divided by yield deflection) for each cycle. A comparison was made between specimens with and without an axial load using the same transverse reinforcement ratio; the specimens without an axial load suffered a more rapid decrease in strength with each complete cycle of load reversals. The specimens with axial loads had higher yield and ultimate shear capacities. Additional results from the tests indicate that the shear capacity of the member should be based on the shear capacity of the column core confined with closely spaced stirrups.

Lee (13) tested beam-column subassemblages subjected to earthquake type loading. The main variable between two types of models was the amount of transverse reinforcement in the joint. The first design was in accordance with the ACI 318-71 code for nonseismic areas. This was assumed to represent an existing structure which was designed without considering seismic loading. The second design was in accordance with ACE 318-71 including "Appendix A" for the design of ductile moment-



resisting space frames. The testing included virgin & repaired specimens of both types. Results from these experiments demonstrated that epoxy injection and removal and replacement techniques of repair can effectively restore the stiffness, strength and energy dissipation capacity of beam-columns. The repaired specimens were found to be stronger than the original specimens at the same deflection level due to the strain hardening of reinforcement and to the higher strength repair materials. Because of the specimens increased strength, the beam to column joint is usually stressed to a higher level, thus creating the possibility of damage moving from the beam to the unrepaired joint. Also, Lee concluded that stirrups should be designed to carry all of the shear force at the points of maximum moments.

A comprehensive collection of the most recent literature presented on the earthquake repair and strengthening of structures was given at the 6th World Conference on Earthquake Engineering. A few of the experimental programs pertaining to reinforced concrete members are outlined below.

Gulkan (7) tested two three-fourths size beam-column connections which were subjected to reversed cycle deflections of double curvature before and after repair. The columns were loaded axially while the beams were loaded in reversed shear to produce the double curvature. The only difference between the two specimens was the lack of the beam stub representing an out-of-plane beam framing into the joint. After failure of the virgin specimens, the original shell of the column was chipped off and replaced with more longitudinal and transverse reinforcement and concrete cast around the original core. This repair technique improved the strength of the column considerably but forced failure into the joint core.

Higashi and Kokusho (10) investigated strengthening methods of existing reinforced concrete buildings. Three experimental test procedures were conducted with respect to these methods.

In the first test a comparison was made between a monolithic shear wall cast with a rigid frame and a rigid frame strengthened by a shear wall poured under pressure. Results from the above test show remarkable increases in the strengthened frame to a degree almost equal to the monolithic shear wall. Rigidity and lateral capacity were increased

substantially under large deflections. Although the behavior under working loads were similar, the mode of failure between the two specimens was different.

The second test procedure consisted of strengthening columns by the addition of wing walls at the sides of the existing columns. The most substantial increase in rigidities and strengths occurred when the wall reinforcements were welded to the hoops in the columns before the walls were cast. Other methods of fastening the wing walls (steel anchor pieces, mortar grouting, etc.) did not show significant strength increases.

In the third test two specimens were compared; (1) an existing reinforced concrete column, and (2) the same column in (1) with welded wire fabric wrapped around the column and mortar poured in place. The column in (2) had gaps at both ends to prohibit spalling of the column at the face of the joint. The results indicated that (2) showed definite increase in the ductility and deformation capacities under reversed cyclic loading. Due to the additional reinforcement, the confinement area of the column was increased and therefore, the ultimate capacity of the existing column was guaranteed.

Freeman (6) described modification of an existing hospital facility to satisfy the new Veterans Administration (VA) seismic design criteria. Since the new criteria was more severe than the original, a response spectrum modal analysis was made with the aid of a digital computer program. The output data provided the force distribution to the members for these modes of vibration.

Several strengthening modification schemes were evaluated for their feasibility and economic application. The proposed scheme was a combination of a shear wall and rigid reinforced concrete frame placed around the perimeter of the 15-story tower structure. The shear walls were cast on the existing mat foundation at the corners of the tower and extend its full height. Pair like columns were then cast at the present exterior column lines to form the rigid frame. A majority of the lateral force resisting capacity has been offered by the shear walls, but the frame system reduced the buildup of overturning moments at the base of the shear walls to produce a ductile seismic resistant structure.

Strengthening has been accomplished along with the repair of

structures. The repair of the Mene Grande Building, Caracas, Venezuela, after the earthquake of July 29, 1967, included the placement of additional transverse reinforcement in the columns (8).

The repair of the Holy Cross Hospital after the San Fernando Earthquake included the strengthening of some columns (17). In locations where the columns had failed, damaged concrete was removed, and new ties were placed. Gunitite was then shot in place. Kajfasz (12) found that concrete beams could be adequately strengthened in shear by epoxy bonding steel stirrups to the exterior of the beams.

The past research has shown that reinforced concrete columns do fail in shear under earthquake forces and that rapid deterioration of strength may occur if insufficient shear reinforcement is present. Yet, little research has been done to determine what methods may be used to strengthen the shear resistance of existing columns and what the adequacy of those methods might be. This experimental program examined some appropriate strengthening methods to determine their potential for improving the earthquake resistance of existing columns.

## 2. EXPERIMENT DESIGN

### 2.1 Design Philosophy

In order to investigate strengthening techniques, it was necessary to design experimental models which were weak with regard to earthquake resistance; yet, the test specimens needed to model actual existing construction. Because of laboratory considerations, the size of the models were limited, but the model size needed to be large enough to represent accurately such behavior as bond of reinforcement and aggregate interlock for shear.

Therefore, the specimens were designed as two-thirds scale model columns according to provision in ACI 318-63 ( 2 ) without regard to earthquake effects or to concepts of ductile concrete which were developed during the 1960's (Blume Newmark Corning 1). The overall depth of the column was chosen as 10 in. to correspond to models tested by Wight and Sozen (20). The width of the specimen was set at 10 in. (unlike Ref. 20) because the typical reinforced concrete column is square. Also typical of existing columns are reinforcement ratios ( $\rho$ ) between 2 percent and 3 percent, and ratios of core dimension ( $d - d'$ ) to thickness ( $h$ ) of 7 to 8. This ratio is generally termed  $\Gamma$ . As shown below, the model specimens had  $\rho$  and  $\Gamma$  ratios within these ranges.

Past earthquakes have demonstrated that reinforced concrete columns often fail in the first story just below their connection with the second floor girders. The stiffness of the second floor and the structure above is often much greater than that of the first columns; this rapid transition in building stiffness apparently induces significant shear together with flexure and axial load in the columns which results in column failure. Furthermore, large interstory lateral deflections induce a P- $\Delta$  moment in those column.

In order to model this weak column - stiff girder connection and to provide a P- $\Delta$  effect, a model like that shown in Figure 2.1 was selected. The large center block represents the stiff girder connection. With a constant axial load, the specimen was flexed in single curvature by applying a lateral load at the center block. The P- $\Delta$  moment was generated by the difference in the line of action of the axial force and

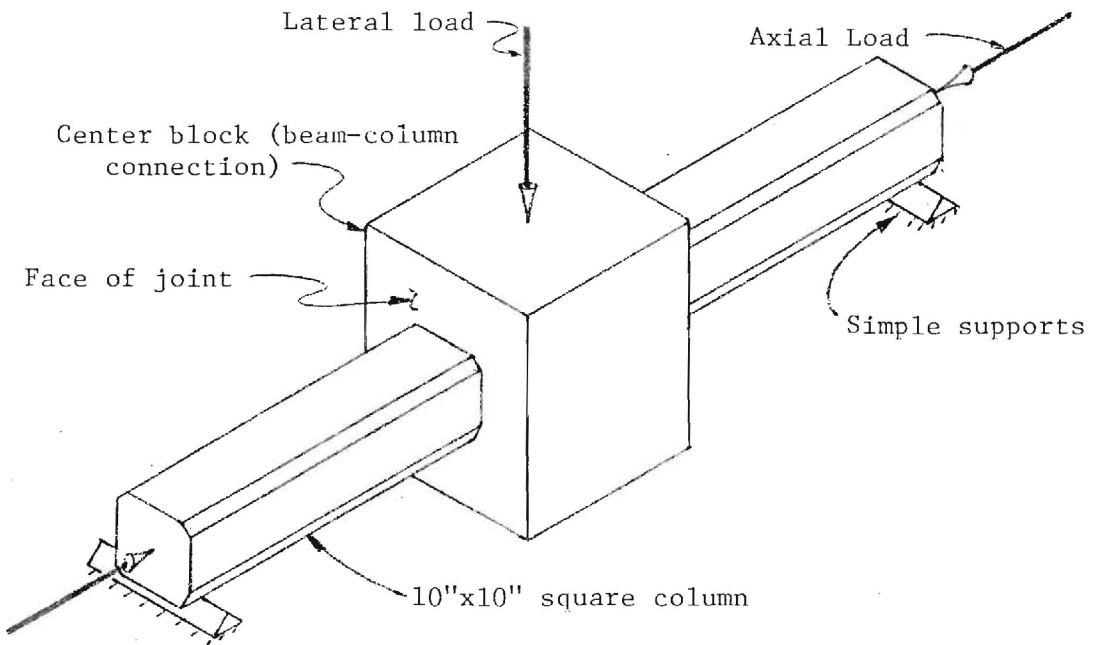

Figure 2.1 Column test specimen under axial load and flexed in single curvature.

the deflection at the column-block joint.

The specimen was symmetric about the center line, and in the elastic range the deflections were also symmetric. Therefore, each half of the specimen represented the upper half of this hypothetical first story column. The specimen was designed to be typical of reinforced concrete columns, but it was not conceived to model all possible variables. The purpose of the tests was to develop a qualitative understanding of these simple strengthening techniques rather than to explore the range of parameters affecting reinforced concrete column response.

## 2.2 Specimen Design

As shown in Figure 2.2, the 10-in. square columns were reinforced with a No. 7 deformed bar in each corner and with 11 gage (0.22 in. diameter) ties at 10 in. spacing. The original design called for Grade 60 steel and a concrete compressive strength ( $f'_c$ ) of 4000 psi. As listed in Table 2.1 below, the actual material strengths were different than those design strengths. No "special transverse reinforcement" as required by current standards (ACI 318-77 & SEAOC Code) was included for concrete confinement or for shear resistance. The columns were purposely designed so that the shear resistance provided by the concrete under an 80 kip axial load would be about 15 percent less than the lateral load which would cause the ultimate moment at the column-center block joint. Shear calculations based on ACE 318-77 ( 3 ) were known to be somewhat conservative ( 16 ), and it was desired that the specimens be weak in shear so that the strengthening methods would be required to aid in the shear resistance.

Design for a full size column based on ACI 318-63 would require a  $1\frac{1}{2}$  in. cover as opposed to the 1 in. cover used. But that code does not allow use of  $\frac{1}{4}$  in. diameter ties as used in these specimens.

The shear span of 50.75 -in. was chosen to fit existing laboratory equipment and to model at two-thirds scale one-half the height of an actual column.

## 2.3 Specimen Construction

### 2.3.1 Unstrengthened Columns

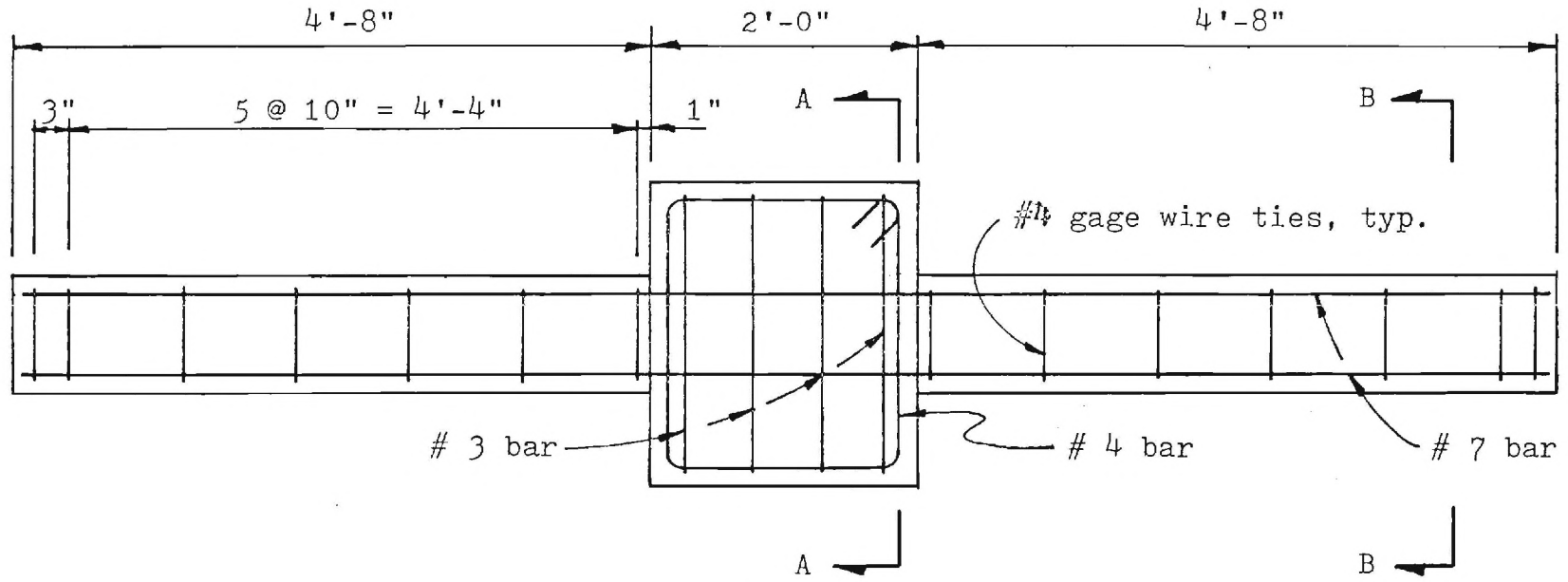

Table 2.1 Material Properties

Specimen	$f'_c$ (psi)	$f''_c$ (psi)	#7 reinf. $f_y$ (psi)	Strengthening System	Strengthening $f_y$ (psi)
1	6350	5540	56,800	None	-
2	6470	6220	56,800	Packaging Bands	93,700
3	6350	6390	56,800	No. 2 bar Spiral	66,900
4	6470	6130	56,800	U-clamps	42,600* 34,100**

\* 2" x 5/16 bar

\*\* 3 x 5 x 5/16 angle



Elevation

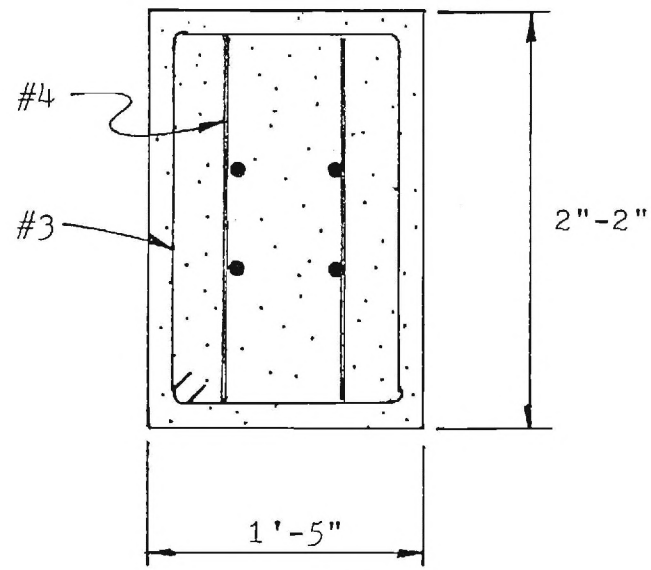

Section A-A

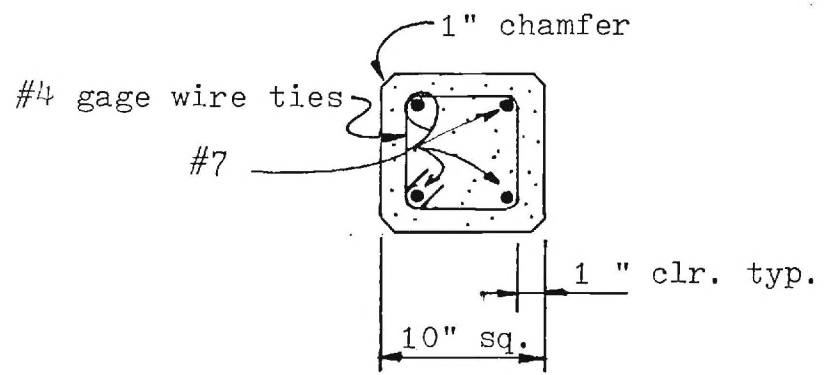

Section B-B

Figure 2.2 Column reinforcing bar design.

The four column specimens were cast in two pours: Specimens 1 and 3 at one time, and Specimens 2 and 4 several weeks later. The four specimens had identical plywood forms (Figure 2.3).

The main and transverse reinforcing bars were strain gaged as discussed below, and then they were tied into cages (Figures 2.4,2.5). The cages were positioned into the forms using precast cement blocks as chairs.

A nominal 4000 psi concrete with a 3/4 in. maximum sized aggregate was ordered from a local supplier and was delivered in a ready-mix truck. For each pour, slump test assured that the slump was greater than 4 in. for workability. The concrete was poured directly from the truck into the forms (Figure 2.6). At the same time, nine 6-in. x 12-in. concrete test cylinders were cast. As shown in Figure 2.6 the columns were cast horizontally so that no cold joint was formed at the column to center block joint. Vibration with a spud vibrator assured compaction.

About four hours after casting, the forms and test cylinders were covered with wet burlap. The burlap was kept moist for one week, after which the forms were removed and the specimens placed within the laboratory building. Cardboard forms from three of the test cylinders were removed one day after casting, and the cylinders were stored in a fog room, 100 percent humidity at 73°F, until the cylinders had aged 28 days. The remaining test cylinders were kept with the specimens and were cured under identical conditions.

### 2.3.2 Strengthening Techniques

Specimens 2,3 and 4 were strengthened using different techniques after the columns had cured for a minimum of one month. Specimen 2 was strengthened by hooping the column with 2-in. wide and 0.045-in. thick steel strapping bands; such bands are used typically for packaging. Figure 2.7 shows the first band being tightened around the column using a lever device; one end of the band was fixed in the base of the device while the other was secured in a spindle. The spindle was rotated by the lever, and the band, thus, was tensioned. One free end of the band was lapped over the hoop and was secured with two metal clips (figure 2.8) by crimping the clips with special pliers. As the lever device removed, the tension in the band was released. As the band

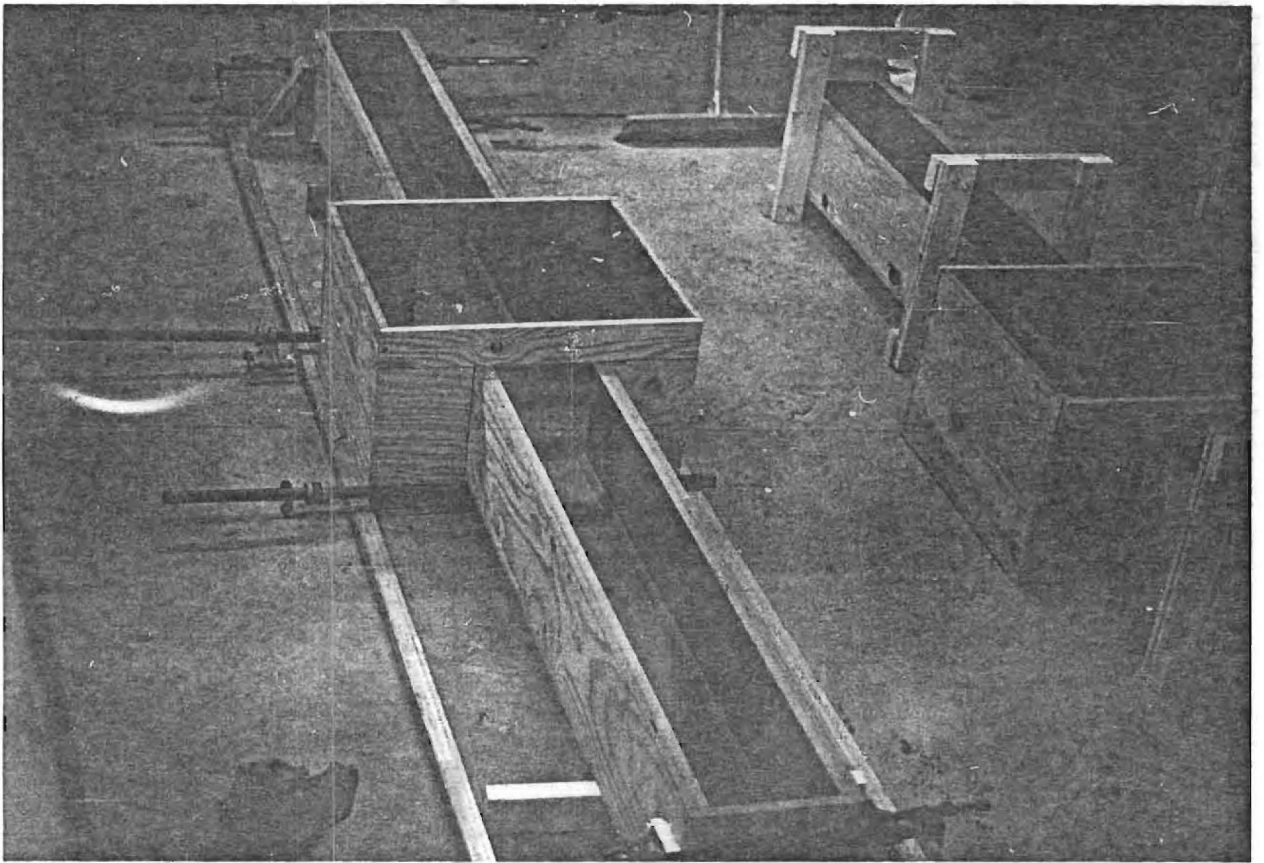

Figure 2.3 Typical form for column specimens.

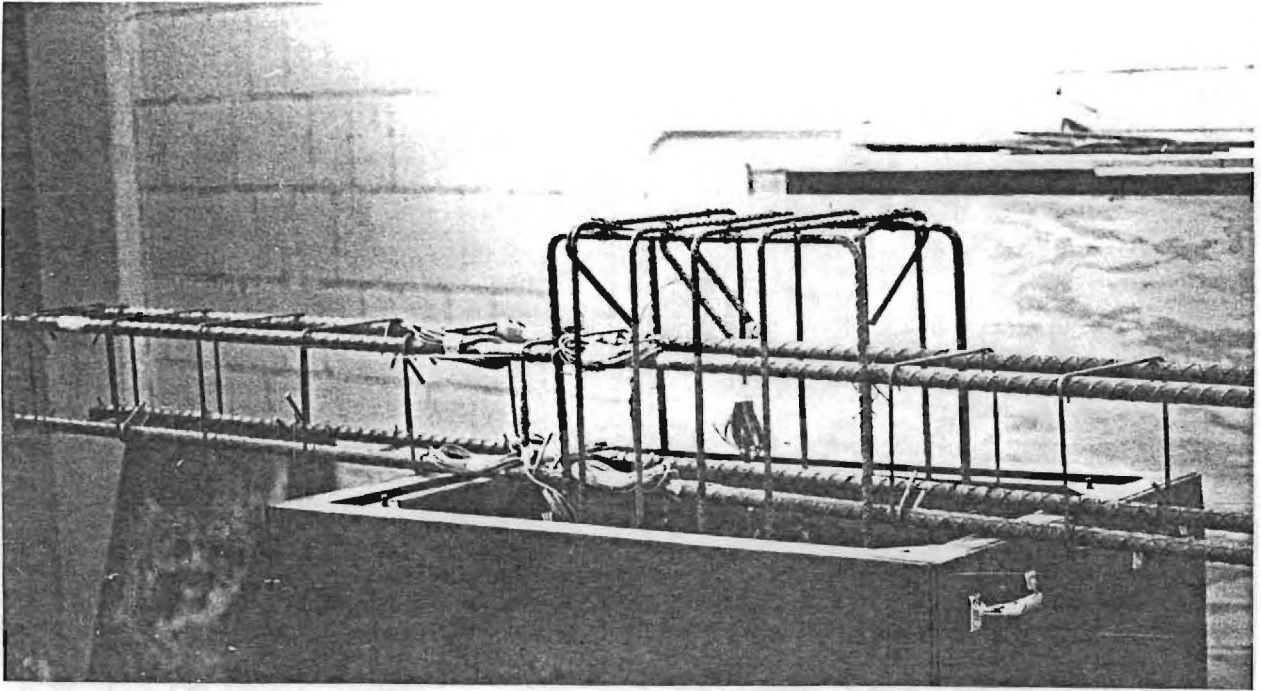

Figure 2.4 Reinforcing bar cage.

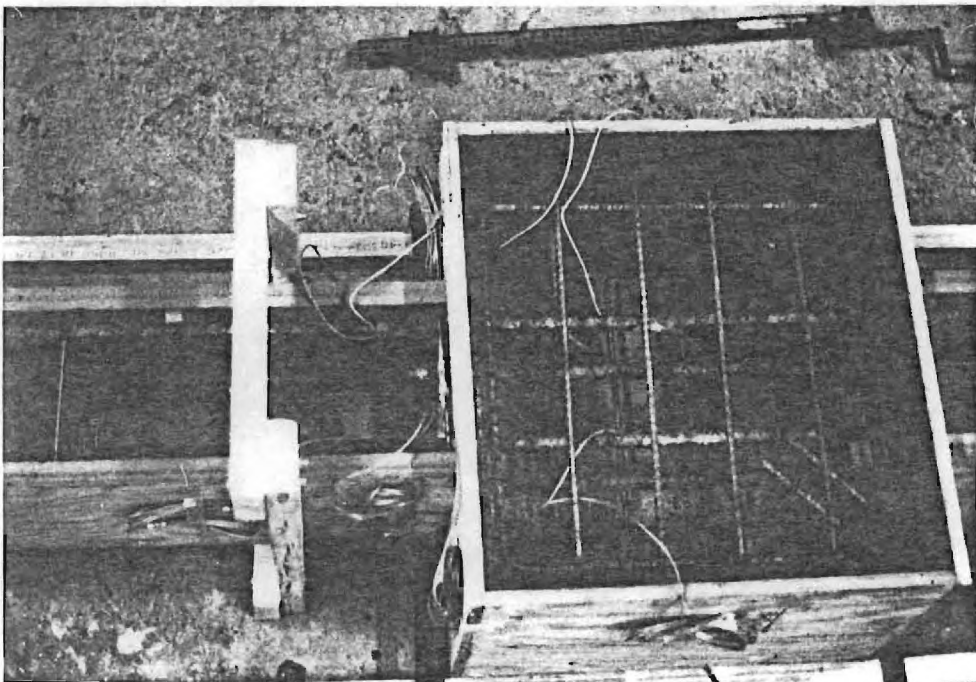

Figure 2.5 Reinforcement in forms.



Figure 2.6 Casting column specimens.



Figure 2.7 Tightening banding around Specimen 2.



tension decreased, a gap ranging from 1/8 in. to 3/8 in. occurred between the band and the column; although the bands remained tight around the corners\*.

The first band next to the joint was spaced 1 in. clear from the joint. The other bands were spaced on 4 in. centers over a distance of 40 in. on each side of the joint. The gap beneath each band was packed with a non-shrink grout (Embeco 636 by Master Builders) to assure confinement. (Figure 2.9).

Specimen 3 was strengthened with a rectangular spiral. A plain 1/4-in. diameter steel rod was hammered around the column to form a spiral with a 1 1/16 in. pitch. A starting loop (zero pitch) was placed within 1/2 in. of the joint. For ease of construction, straight 10 ft. lengths of the rod were used to form the spiral. After one 10 ft. length had been wrapped, the next length was lap welded to the end of the existing spiral (Figure 2.10). A lap weld of 4 in. was used; it was calculated that this length would develop the yield strength of the rod.

Gaps between the spiral and the column were as large as 1/16 in. These gaps and the space between the rods was filled with a Portland cement grout made of equal parts sand and cement and sufficient water to provide a workable mortar. (Figure 2.11). The column was thoroughly wetted prior to applying the mortar.

Specimen 4 was strengthened with U-shaped clamps. The clamps were made of 2-in. x 5/16 in. hot rolled steel bar cut 10 in. long which was fillet welded to A36 steel angle 5 in. x 3 in. x 5/16 which was cut 2 1/4 in. wide (Figure 2.12). The angle had a lower yield stress than the bar; so the angle was cut wider than the 2 in. bar so that the total yield force of the angle and bar would be equal.

Holes of 13/16 in. diameter were drilled in the 3-in. outstanding legs of the U-clamps for A325 3/4-in. diameter bolts. It was calculated that the yield force of the bolt was greater than the yield force of either side of the clamp.

---

\* The author originally desired that the bands remain tensioned, but the lever device required about a one-half inch gap beneath the band. As the device was removed, this space permitted the band to slacken.



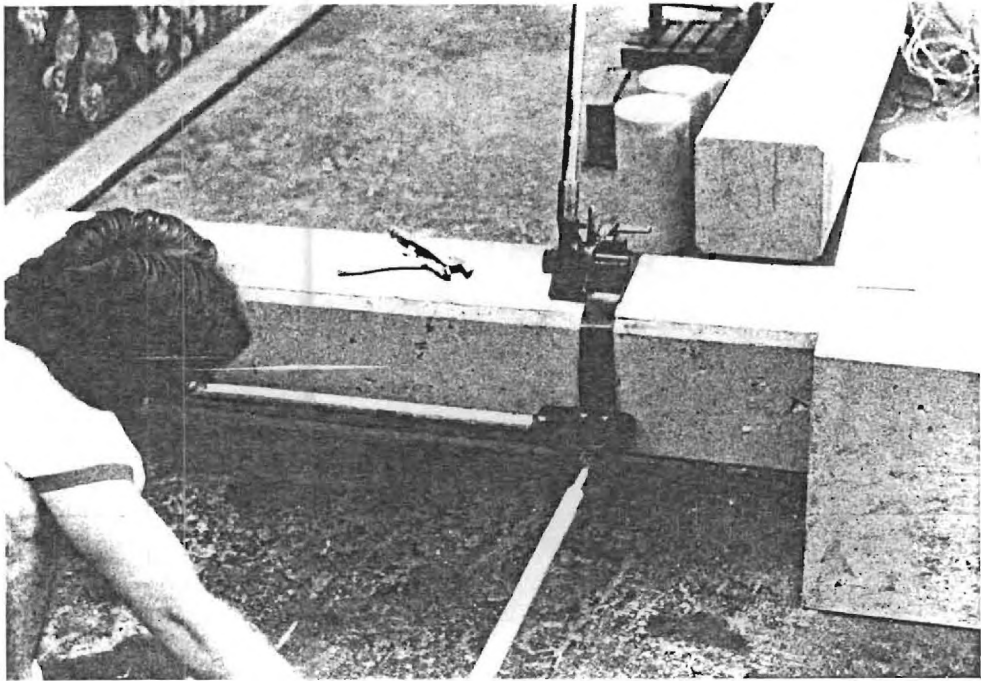

Figure 2.8 Crimping metal clips to secure banding hoop.

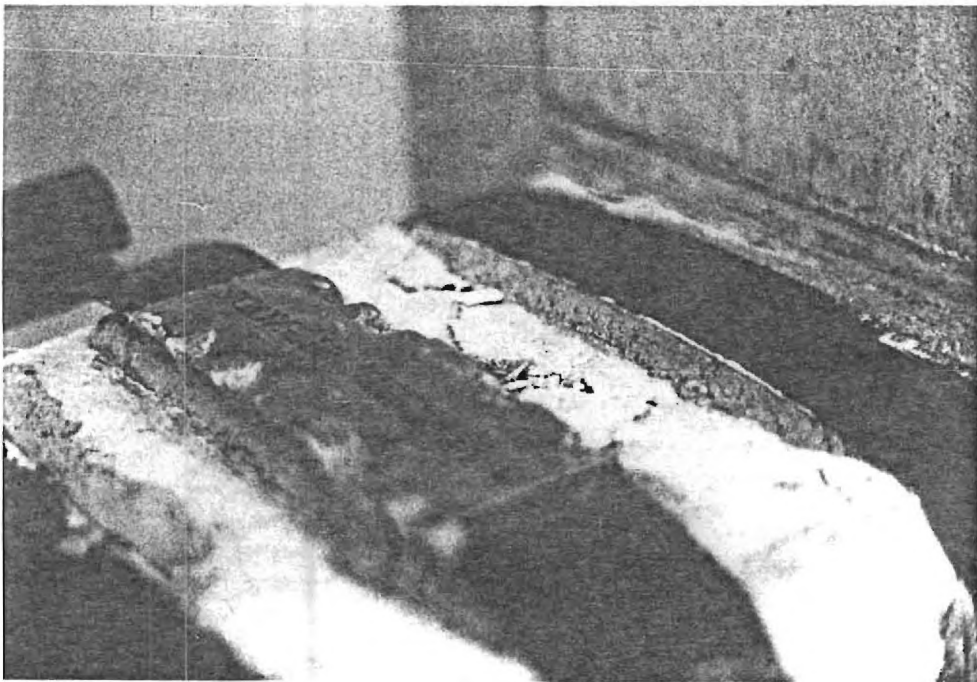

Figure 2.9 Specimen 2 banding showing clips and non-shrink grout packed beneath the bands. Photograph taken after deflection sequence was completed.

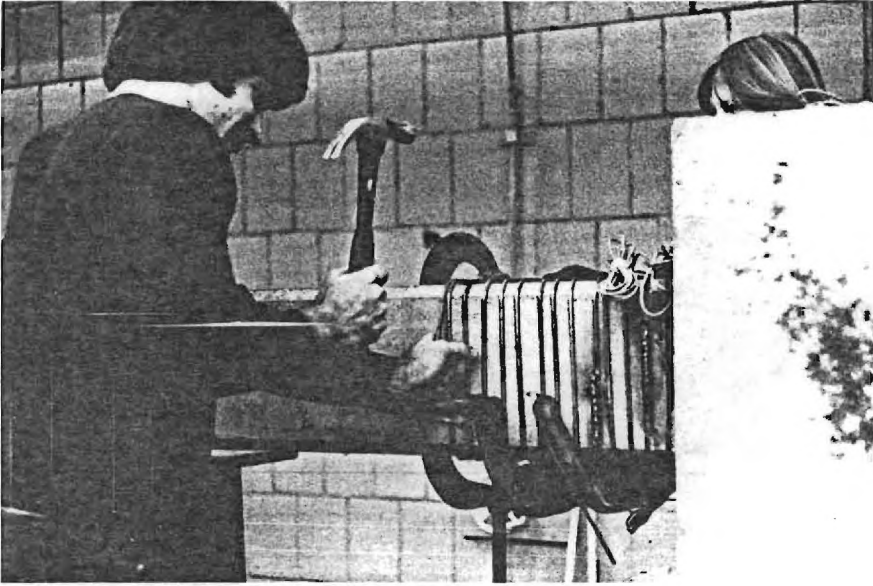

Figure 2.10 Hammering No. 2 bar around Specimen 3. Note lap welds.

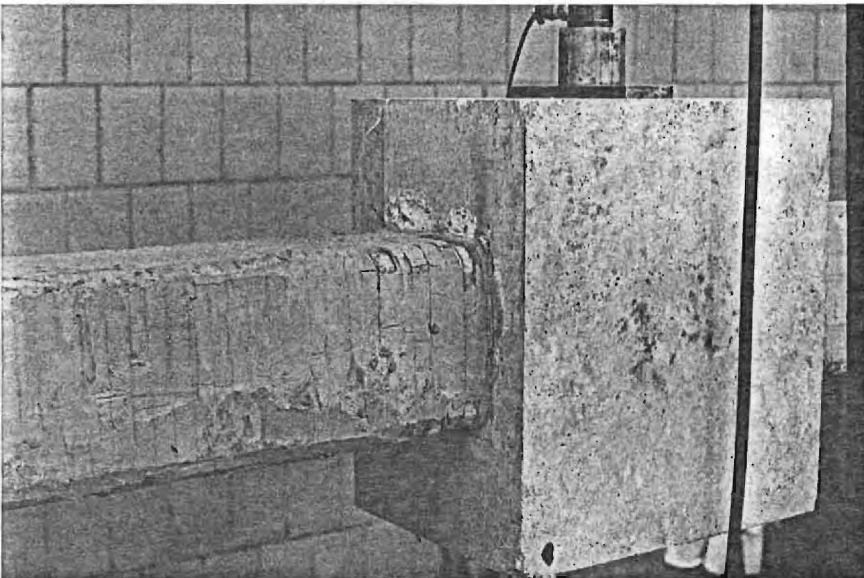

Figure 2.11 Specimen 3, cement grout was mortared around the rectangular spiral. Photograph was taken after deflection sequence was completed.

Once fabricated the U-clamps were easily secured around the columns and bolted together. The clamps fit tight and required gentle hammering to seat them. The first clamp was spaced 1-in. clear from the joint, while the remaining clamps were spaced on 4 1/4 in. centers over a 40 in. distance (Figure 2.13).

### 2.3.3 Materials

Detail description of material properties are given in Appendix A. General properties of the materials used to construct the specimens is given below and in Table 2.1

The compressive strength of the 28 day fog cured concrete cylinders ( $f'_c$ ) was 6350 psi for Specimens 1 and 3, and it was 6470 psi for Specimens 2 and 4. As stated above, an additional three cylinders were cast with each column and were cured under identical conditions. These cylinders were compression tested when each specimen was tested; the average strength of these field cured concrete cylinders ( $f'_c$ ) is given in Table 2.1

The tensile stress-strain response for the steel reinforcement is given in the Appendix A; two tension tests for each type of reinforcement were conducted. The average yield stress for the No. 7 bar was 56,800 psi, and the average 0.2 percent offset yield stress for the 11 gage wire was 77,900 psi.

Tension tests of the materials used for the strengthening techniques gave the yield stress results listed in Table 2.1. The yield stress given for the banding steel was the average yield stress of two tests of 3 ft. lengths of material. Two additional tension tests were conducted with two clips in an identical manner to the connection used on the column hoops. These tension tests were designed to examine the capacity of the clip connection. The lapped bands began slipping through the clips at an average load of 7800 lbs., and the bands freely slipped at 8400 lbs. The initial slip load was divided by the gross area of one band of 86,700 psi, a value which was 7.5 percent less than the actual 0.2 percent offset yield stress of the banding. Therefore in calculations regarding the force capacity of the banding hoops, the author believes that the "apparent yield stress" should be used.

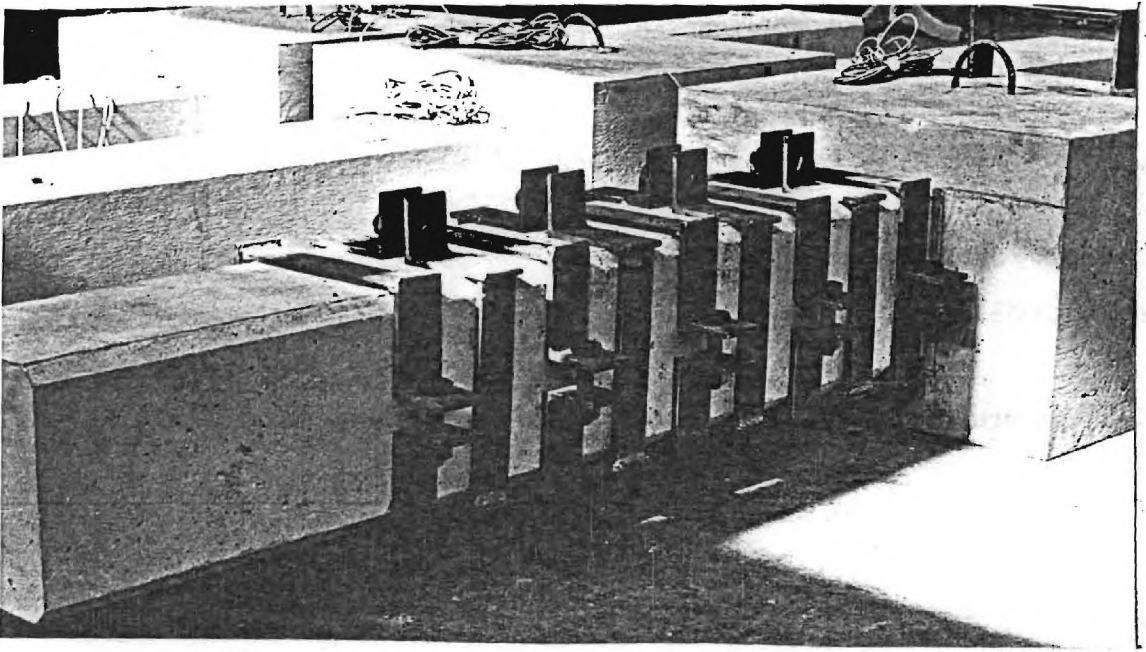

Figure 2.12 U-clamps bolted on Specimen 4.

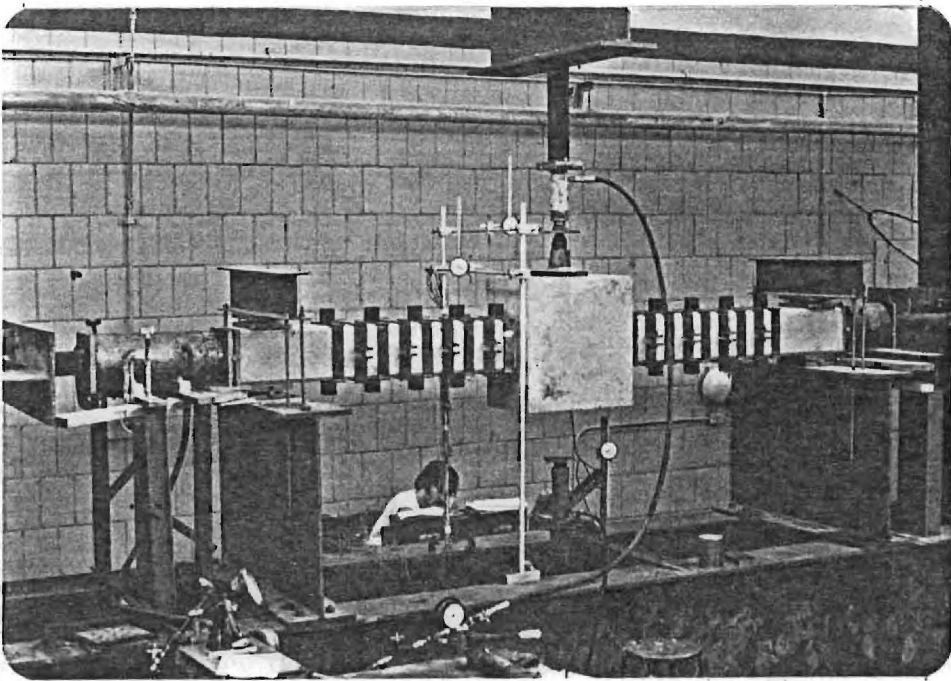

Figure 2.13 Specimen 4 with U-clamps ready for test.

## 2.4 Test Set-up and Instrumentation

Reinforcing bar strain measurements were taken with standard 1/4 in. electrical resistance strain gages. The gages were located at the center of the joint and at approximately one inch from the face of the joint on the main reinforcement (Figure 2.14). Strain gages also were placed on the first column tie from the face of the joint. The gages were bonded to a machined surface of the steel reinforcing bar with a two part adhesive, M-bond 200. An epoxy resin coating was used as a final step to protect the gages against impact during casting (Figure 2.5). Also, strain gages were bonded to the near and far sides of the first strengthening technique from the face of the joint on Specimens 2 and 4 (Figure 2.15).

Figure 2.13 and 2.16 illustrate the test set up. The axial load cell was positioned at the right end of the specimen while the load was applied by a hydraulic loading ram on the left end of each specimen. The lateral load was applied at the center of the joint and monitored by a strain gage load cell which was used for both downward and upward loading. Lateral deflection measurements were taken at the edge of the center block adjacent to the column and at 10 in. from the face of the joint.

## 2.5 Test Procedure

All test specimens were mounted in the structural test frame as shown in Figure 2.13; pinned bearings without rollers were provided for all supports (Figure 2.17). An axial load of 80,000 lbs. was applied with the hydraulic jack; this load was maintained throughout the test sequence or until the column failed. This load produced a stress of 800 psi which was considered to represent a typical working axial stress used by Wight and Sozen (20); so comparison with their results would be facilitated.

Each specimen then was cycled through the lateral deflection sequence shown in Figure 2.18. Lateral loads were applied by the vertically oriented hydraulic jacks located above and below the center of the specimen. Downward deflection and loads were considered positive. The lateral deflection at which the main tension reinforcement would first

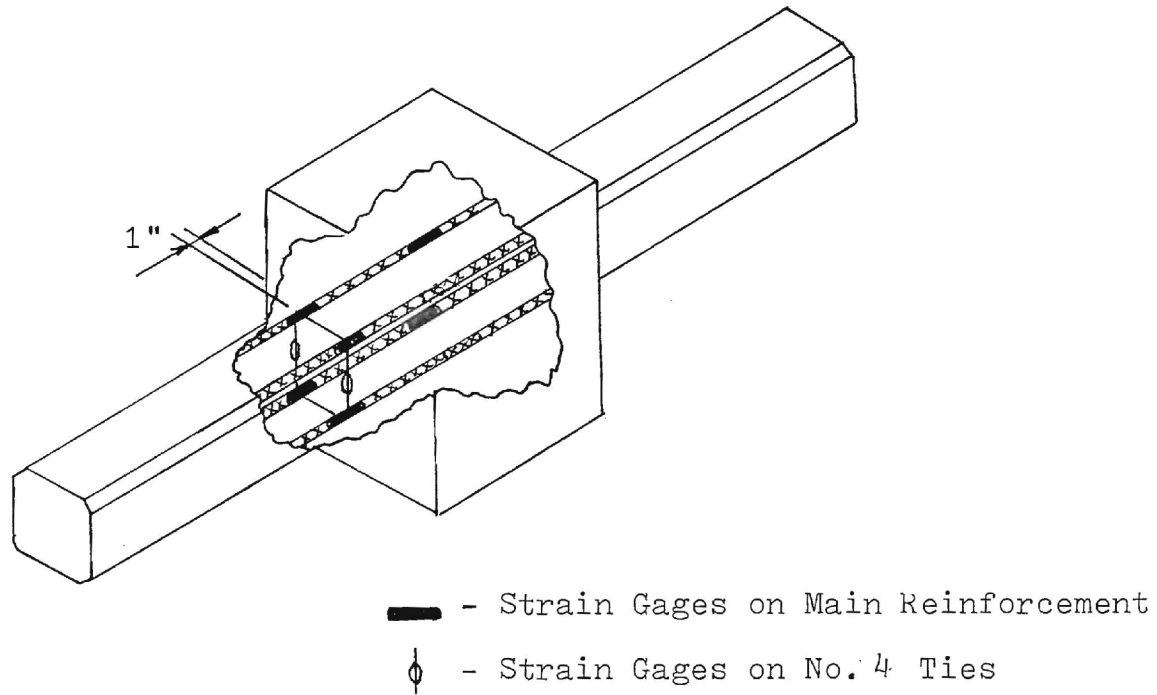

Figure 2.14 - Strain Gage Locations within the Specimen



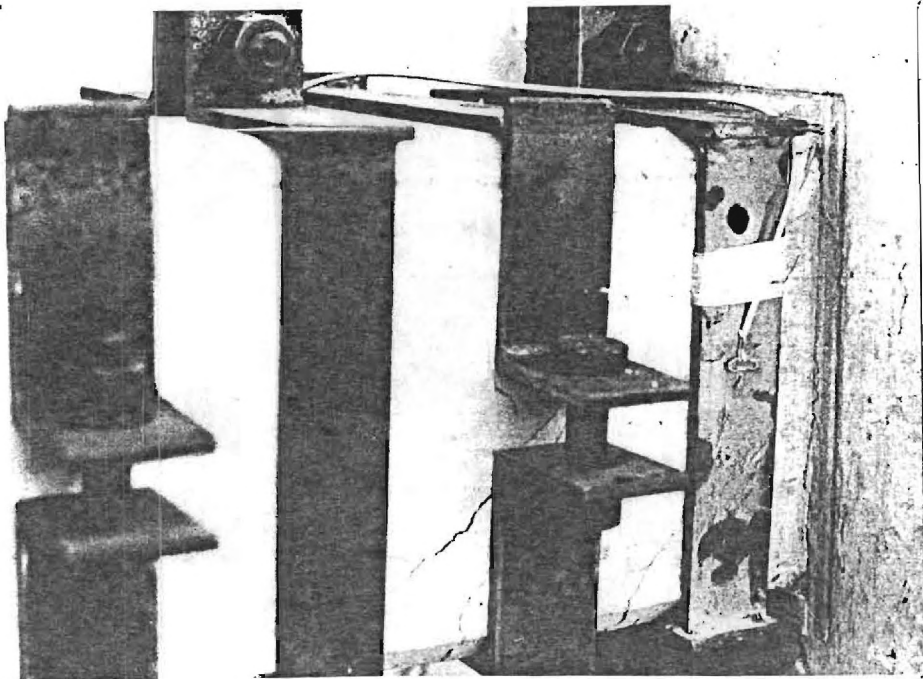

Figure 2.15 Specimen 4, strain gage on U-clamp nearest the joint face. Photograph was taken after deflection sequence was completed.



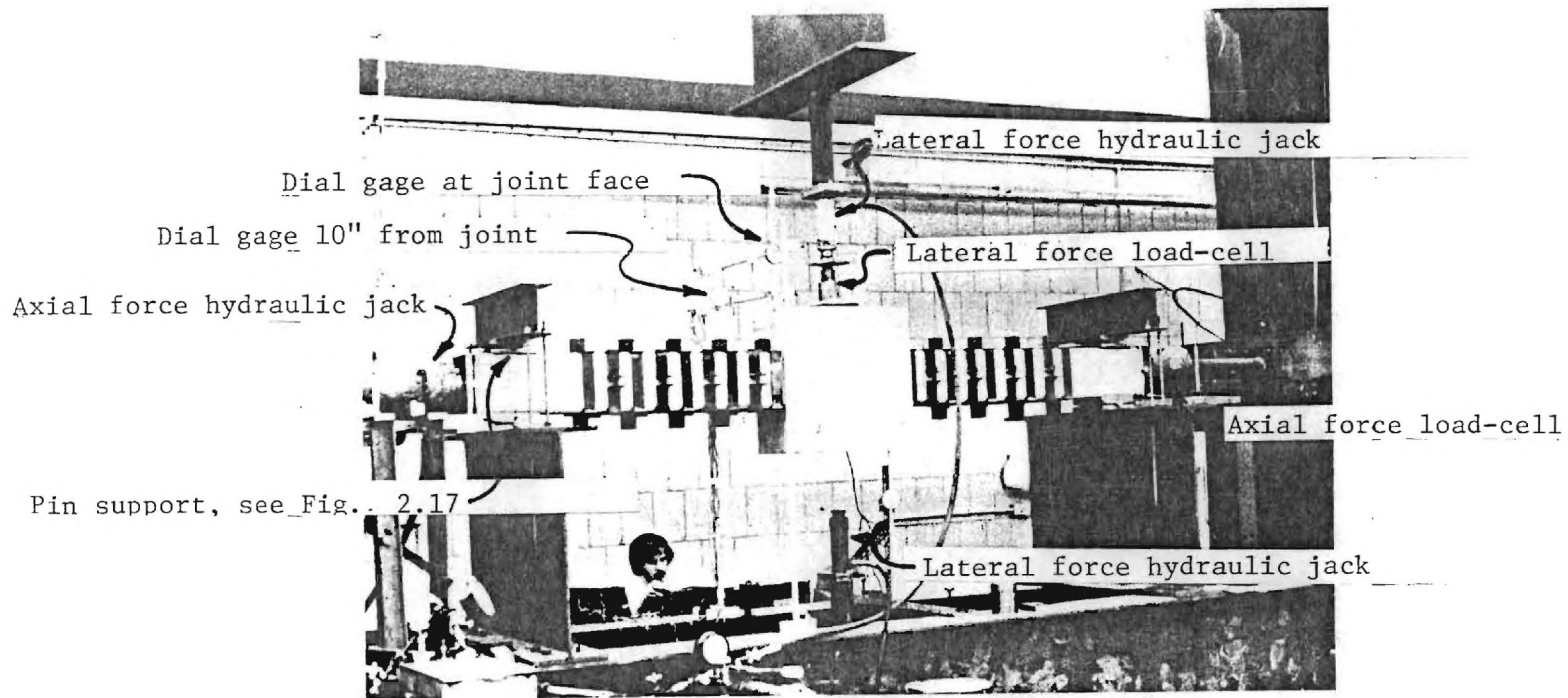

Figure 2.16 Test set-up.

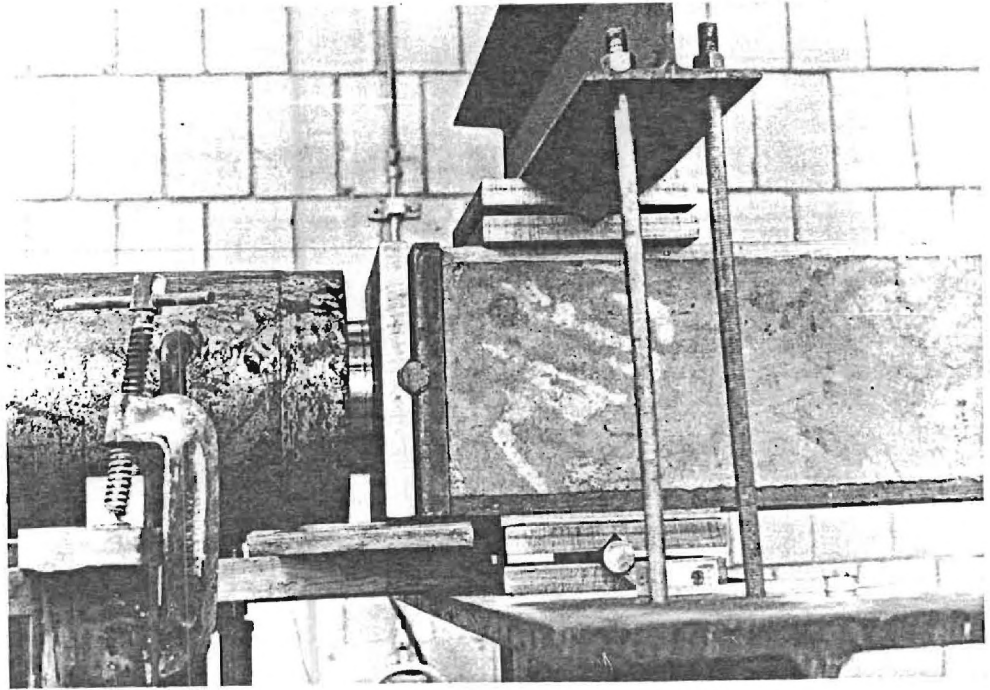

Figure 2.17 Close-up view of pin bearings and axial force hydraulic jack.

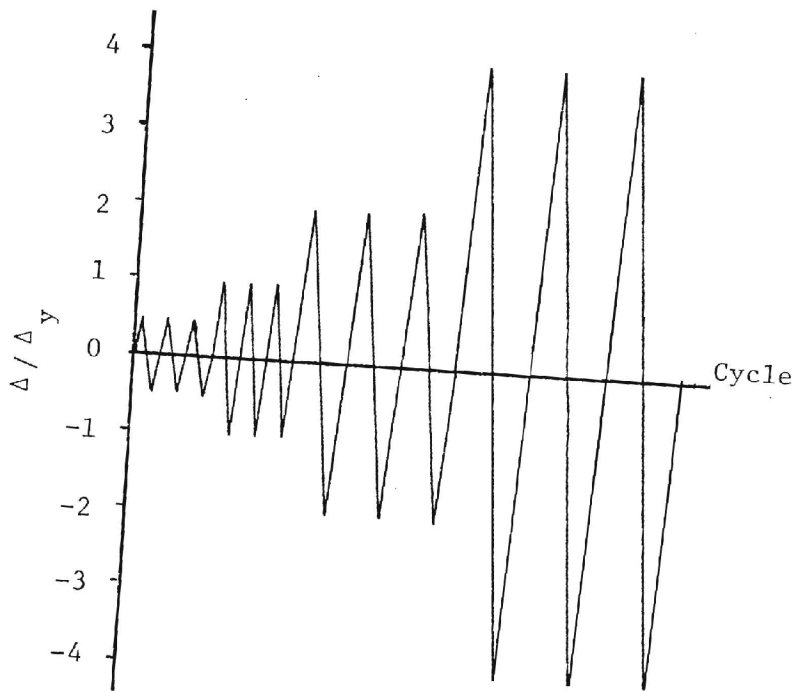

Figure 2.18 Lateral deflection sequence

yield ( $\Delta_y$ ) was calculated. The maximum deflection of the first three cycles was equal to one-half this calculated  $\Delta_y$  value. The maximum deflection of the fourth cycle was to the actual yield deflection level of the specimen. During loading the strain on the tension bars was constantly monitored. When the yield strain was detected, the deflection was continued to the nearest 0.05 in. level for ease of testing. The next three cycles (cycles four through six) were to this actual  $\Delta_y$  level. Thereafter followed three cycles to twice the  $\Delta_y$  level and three cycles to four times the  $\Delta_y$  level. The maximum deflection in a cycle ( $\Delta$ ) was divided by  $\Delta_y$  to give a ductility ratio  $\Delta/\Delta_y$ . Each deflection cycle required 15 to 30 minutes.

### 3. EXPERIMENTAL RESULTS

#### 3.1 Load-Deflection Response

The shear force-deflection response for the four specimens is illustrated in Figures 3.1 through 3.4. Because of the symmetry of the load and specimen, the shear force at the column-joint face was equal to one-half the lateral load. The lateral deflections given in the figures was that found by the dial gage located at the joint face next to the side of the specimen where the reinforcement was instrumented with strain gages (the left side as viewed in the figures). The centerline of the load was off-set  $\frac{1}{4}$  in. toward the side of the specimens with the strain gages in order to force failure on the instrumented side of the models. In the elastic range this slight discrepancy from exact symmetry could not be detected by dial gages placed on either side of the center block. As plastic hinging occurred in the column at the face of the joint, the instrumented side deflected more than the right side.

The four hysteresis curves illustrate that in the cycles to  $\frac{1}{2} \Delta y$  (about 0.3 in.) and to  $\Delta y$  (about 0.65 in.) all specimens behaved nearly elastically. The maximum load did not degrade in the cycles to  $\frac{1}{2} \Delta y$ . The maximum load degraded a maximum of 7 percent between the first and third cycles for the cycles to  $\Delta y$ . The maximum shears to the  $\frac{1}{2} \Delta y$  and the  $\Delta y$  deflection levels are given in Table 3.1, along with the experimentally determined  $\Delta y$ . The reader will observe on the hysteresis curves that the specimens were deflected slightly beyond the actual  $\Delta y$  deflection level during the second three-cycle set in order to facilitate the experimental procedure. Both the yield deflections and yield loads for the four specimens were within 14 percent of each other. The maximum shears observed for the four columns during the entire deflection sequence were within 7 percent of each other. Table 3.1 clearly shows that the specimens appeared stronger in the negative direction (upwards) than in the positive direction (downwards). Dead load of the specimens accounts for about 0.8 kips of the difference in shear force between the two directions. With a correction for dead

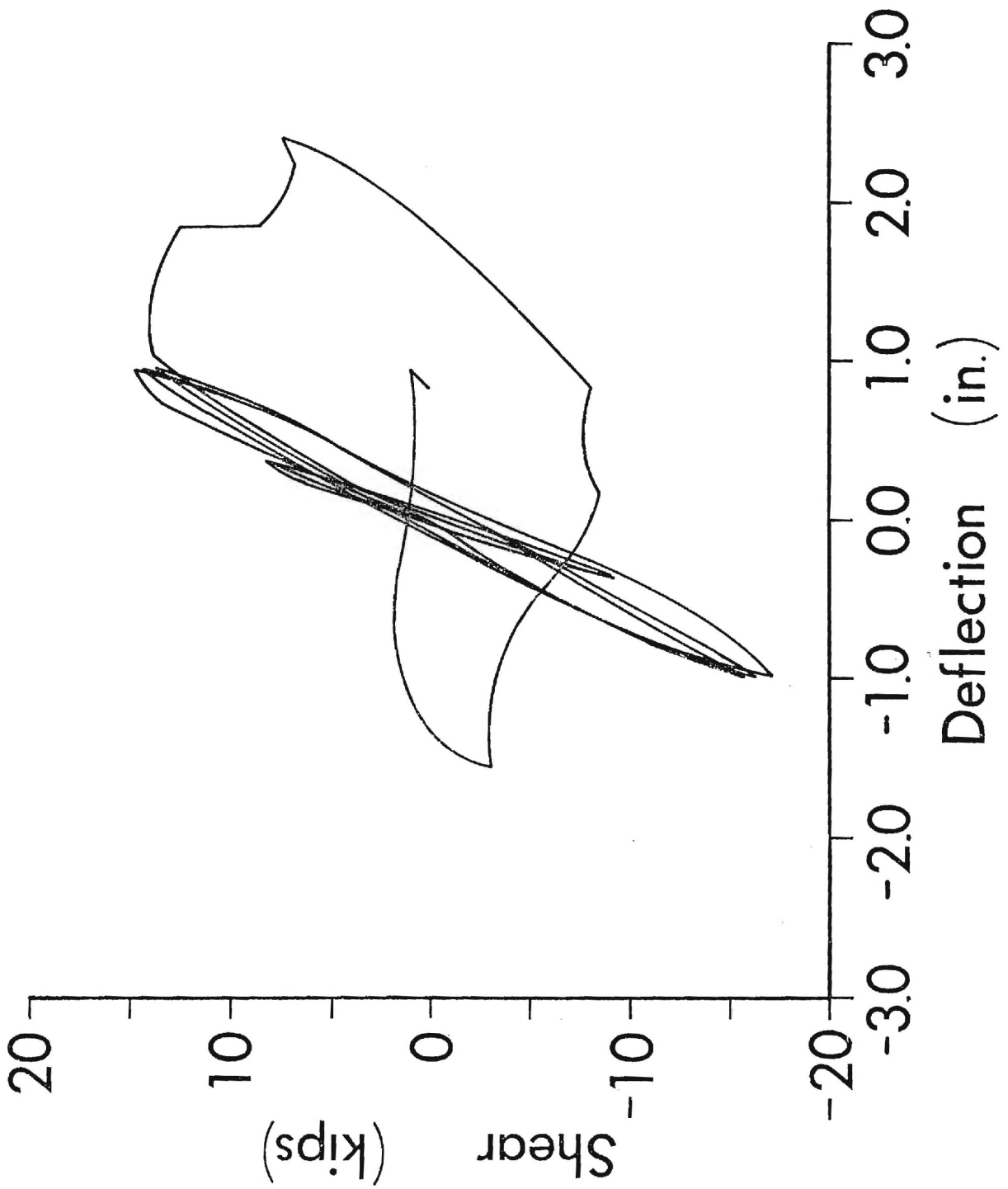

Figure 3.1 Specimen 1, load-deflection response.

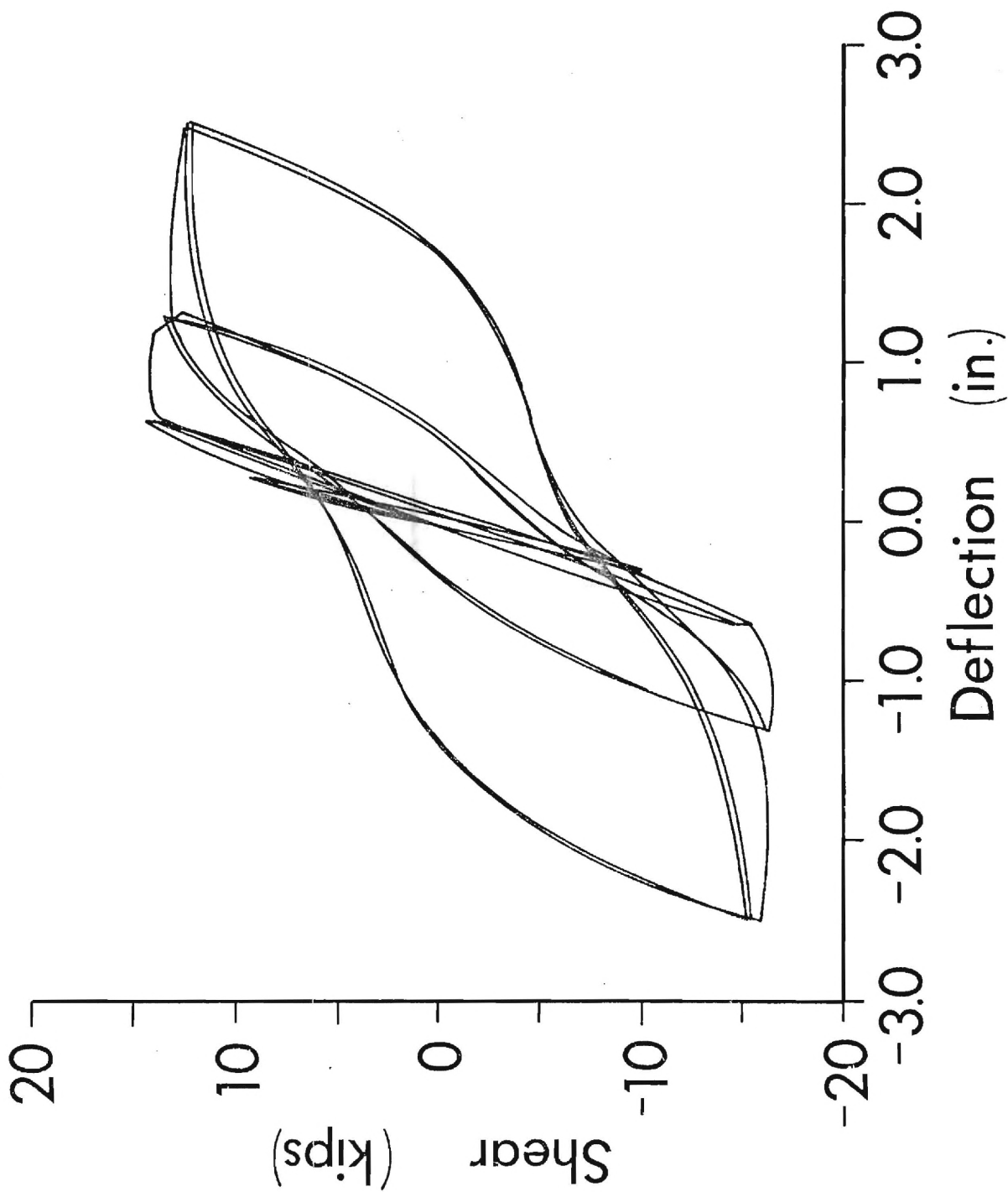

Figure 3.2 Specimen 2, load-deflection response.



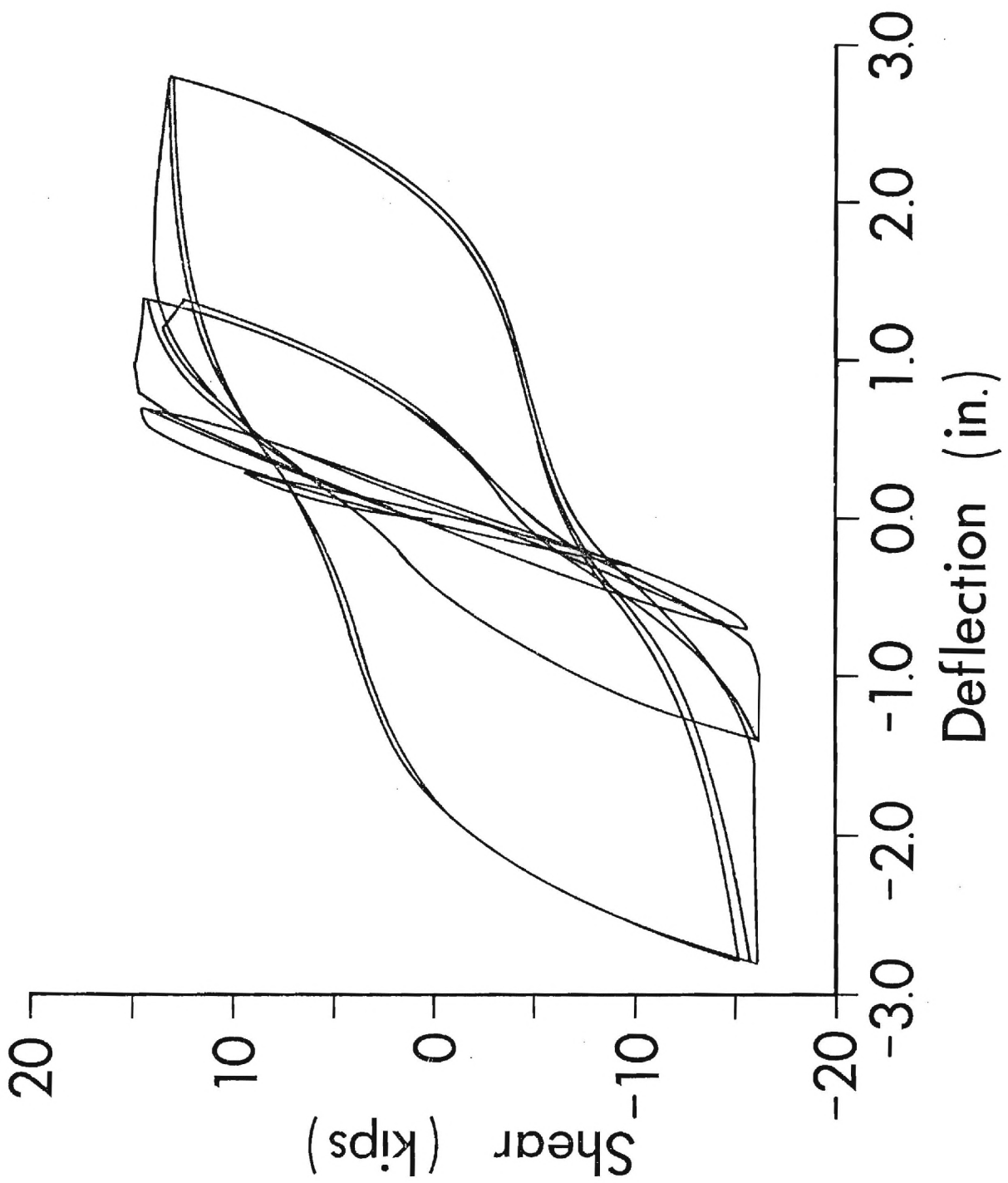

Figure 3.3 Specimen 3, load-deflection response.

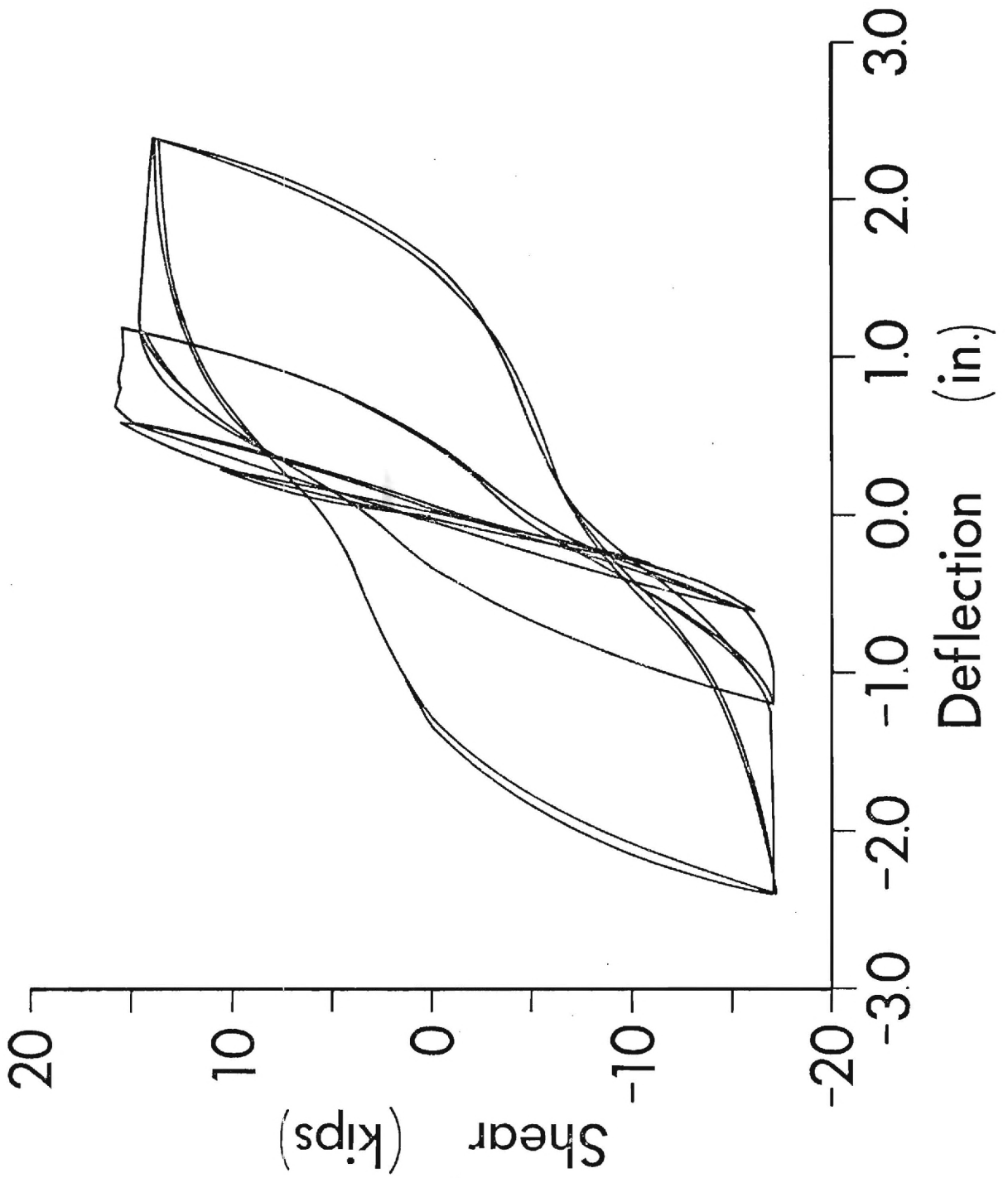

Figure 3.4 Specimen 4, load-deflection response.

Table 3.1 Load-Deflection Data

Specimen	$\Delta y$ Experimental	Max. Shear (kips) first 3 cycles*		Max. Shear (kips) Second 3 cycles**		Max. Shear (kips)	
		Positive	Negative	Positive	Negative	Positive	Negative
		Positive	Negative	Positive	Negative	Positive	Negative
1	6.0	+8.2	-9.6	+14.8	-17.3	+14.8	-17.3
2	6.4	+9.3	-10.1	+14.5	-15.1	+14.5	-16.5
3	+6.0	+9.5	-10.1	+14.5	-15.8	+14.8	-16.3
4	+6.0	+10.5	-11.3	+15.5	-16.9	+15.6	-17.4

\* nominally termed  $1/2 \Delta y$

\*\* nominally termed  $\Delta y$

load effect, the difference in applied shear is smaller. The remainder of the difference is believed to have resulted from accidental eccentricity of the axial load.

At deflections beyond  $\Delta_y$ , the load-deflection response of the unstrengthened column differed markedly from the responses of the other columns. During the seventh deflection cycle with a planned maximum deflection of 1.5 in. ( $2-\Delta_y$ ), Specimen 1 failed at a deflection of 1.48 in. Figure 3.1 shows an immediate drop in lateral load. Simultaneously, the axial load fell to about 50 kips from the original 80 kips. Attempts to return the axial load to 80 kips caused spalling of the concrete cover and fracturing of the core. At a later deflection of +2.0 in., the axial load was reduced to zero for Specimen 1. The column effectively had collapsed. The remainder of the hysteresis curve was determined for the column under no axial load.

Specimens 2, 3 and 4 demonstrated similar, stable hysteretic responses during deflection cycles to  $2-\Delta_y$  and to  $4-\Delta_y$ . For the three specimens at deflection cycles to  $4-\Delta_y$ , the load degraded less than 5 percent between the first and third cycles.

For Specimens 2, 3 and 4 as the deflections were increased beyond approximately 1.2 in ( $2-\Delta_y$ ), the lateral load decreased slightly with increased deflection during the first cycle to  $4-\Delta_y$ . This decrease illustrated the P- $\Delta$  effect whereby the moment created by the eccentricity of the axial force due to the lateral deflection had a significant contribution to the moment at the joint. The second and third cycles to  $4-\Delta_y$  did not show clearly this P- $\Delta$  effect.

### 3.2 Physical Observations

After the three cycles to the yield deflection level, Specimen 1 showed prominent cracks which were highlighted (Figure 3.5). At a deflection of +1.3 in. the concrete at the top surface crushed and began to spall (Figure 3.6). At a deflection of +1.5 in. the concrete cover on the top and bottom spalled. The axial load fell to 50 kips and was further reduced with increasing deflections. During increased deflection to +2.0 in., more concrete spalled, the #7 reinforcement buckled, and a single 4 gage wire tie unraveled. Figure 3.7 shows

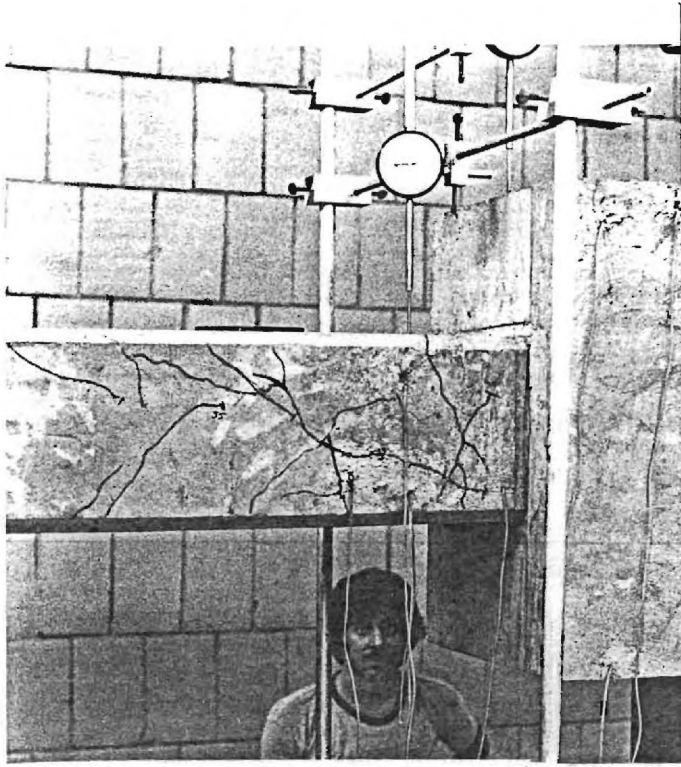

Figure 3.5 Specimen 1 after three cycles to yield deflection.

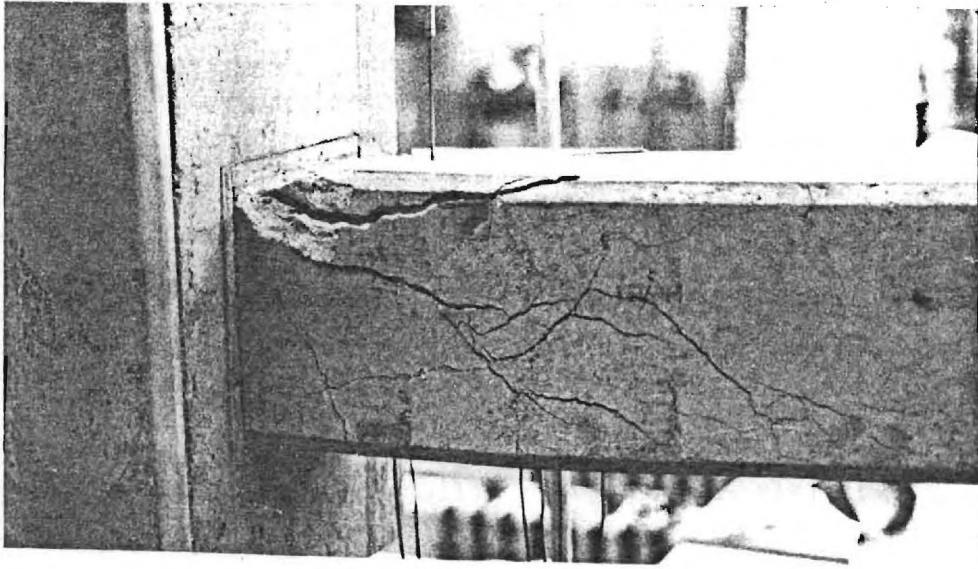

Figure 3.6 Specimen 1, initial crushing at +1.3 in. deflection.

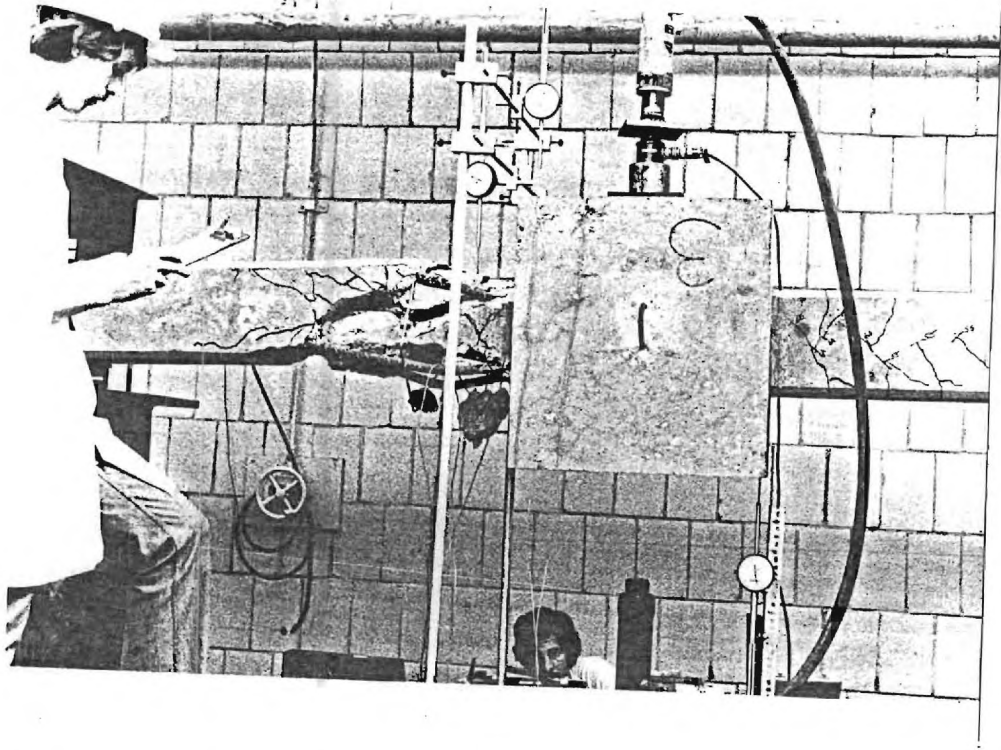

Figure 3.7 Specimen 1 after failure.

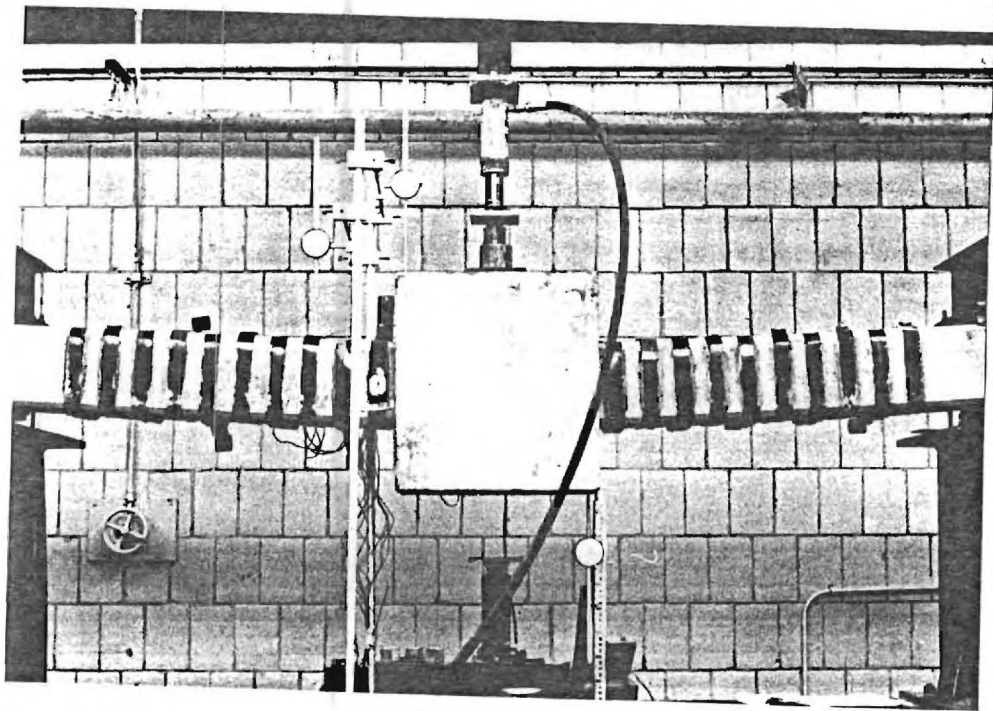

Figure 3.8 Specimen 2 at +2.5 in. deflection.

Specimen 1 as the lateral load was reduced to zero. Reversed cycle deflection forced much of the fractured concrete to fall from the column.

Specimen 2 with the packaging bands for strengthening showed no dramatic events during the entire deflection sequence. Only a single set of diagonal cracks were observed; these were small and crossed about 6 in. from the joint. Figure 3.8 shows Specimen 2 at the maximum +2.5 in. deflection.

Specimen 3, reinforced with the No. 2 bar rectangular spiral, again showed no significant cracking or spalling during the test. Figure 3.9 shows Specimen 3 after the deflection sequence. Some mortar cracked and spalled from between the spirals; the concrete under the mortar appeared undamaged. The figure illustrates that some concrete on the joint face had crushed and spalled.

A set of crossing diagonal cracks was evident in Specimen 4 as shown in Figure 3.10, when the column was at a deflection of -1.2 in. The cracks crossed at the center of the second clamp from the joint. As deflections were increased, these cracks did not widen. Specimen 4 demonstrated no spalling or major cracking during deflections to  $4-\Delta y$  (Figure 3.11). Crushing of the concrete was observed under the clamp nearest the joint during the maximum deflection cycles (Figure 3.12).

### 3.3 Moment-Curvature Response

A rough experimental measure of column curvature was determined by the lateral deflection gages at the column-joint face and at 10 in. from that face. The difference in the deflection measurements were divided by the 10-in. distance between gages to yield an average rotation over the 10-in. space which included the maximum column moment and plastic hinge region. The moment at the joint face was calculated as the sum of the shear times the distance from the support to the joint face and the axial force times the lateral deflection at the joint face. Plots of these calculated moment-curvature relations are shown in Figure 3.13 through 3.16 for Specimens 1 through 4 respectively.

For Specimens 2, 3 and 4 these moment-curvature diagrams closely resembled the load-deflection curves, and were typical for reinforced concrete members dominated by flexural response. The moment-curvature



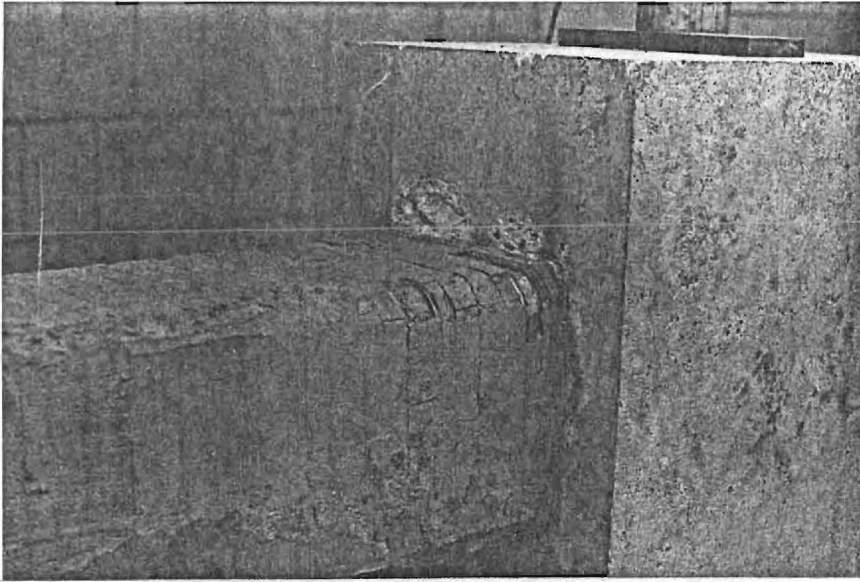

Figure 3.9 Specimen 3 after test sequence.

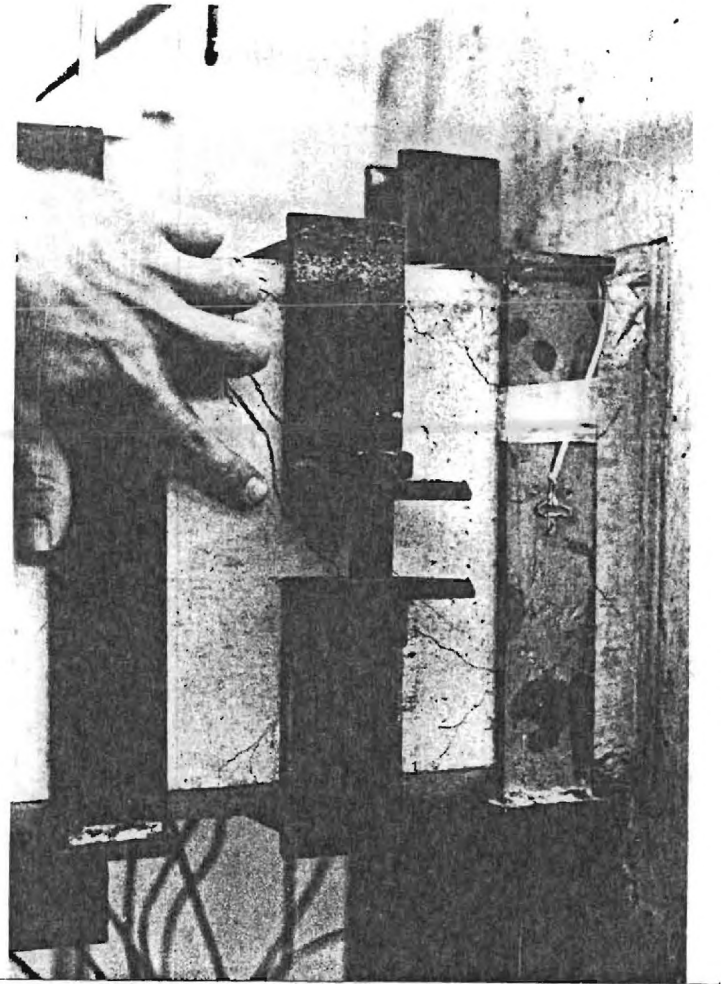

Figure 3.10 Specimen 4 at -1.2 in. deflection.

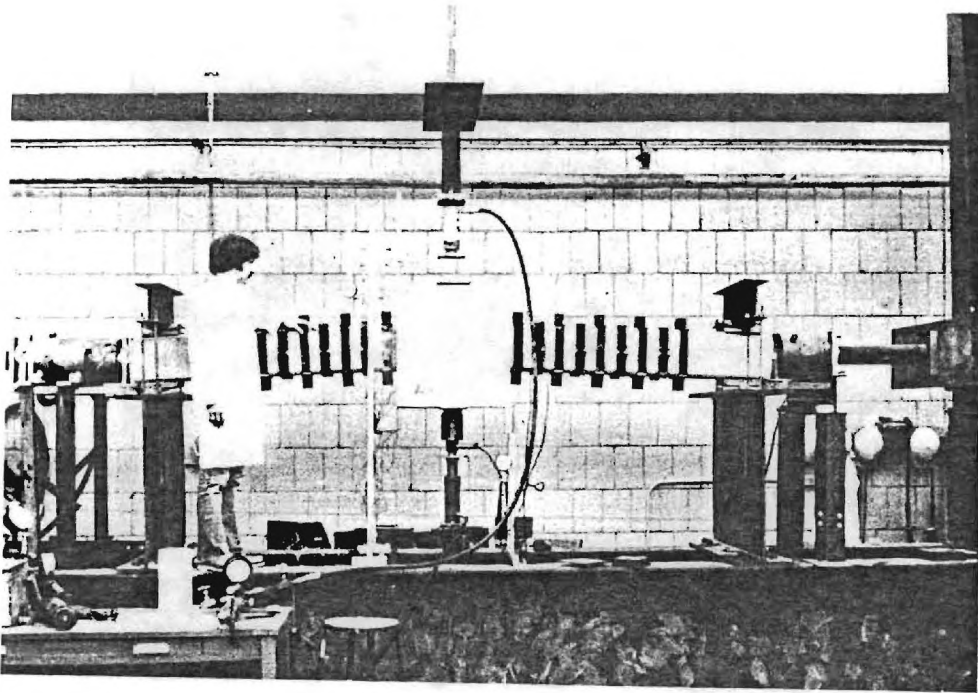

Figure 3.11 Specimen 4 at -2.4 in. deflection.

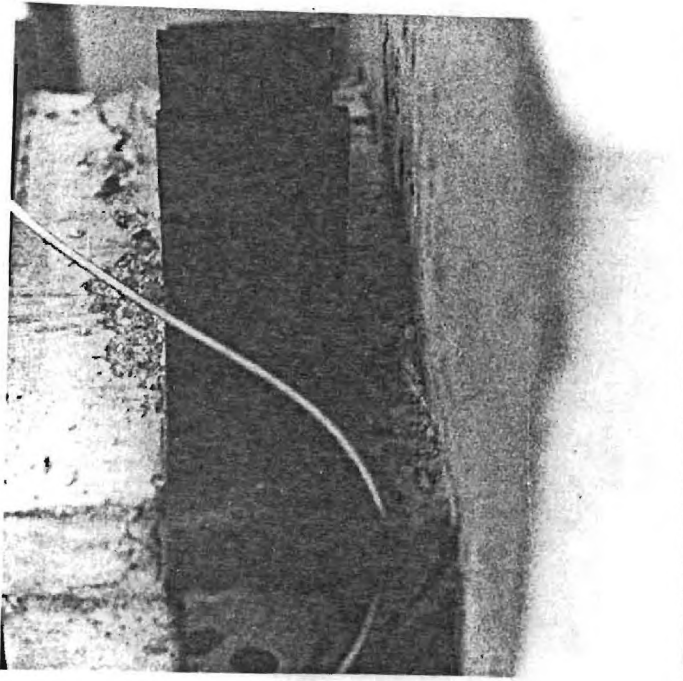

Figure 3.12 Specimen 4 showing crushing under U-clamp after deflection sequence.

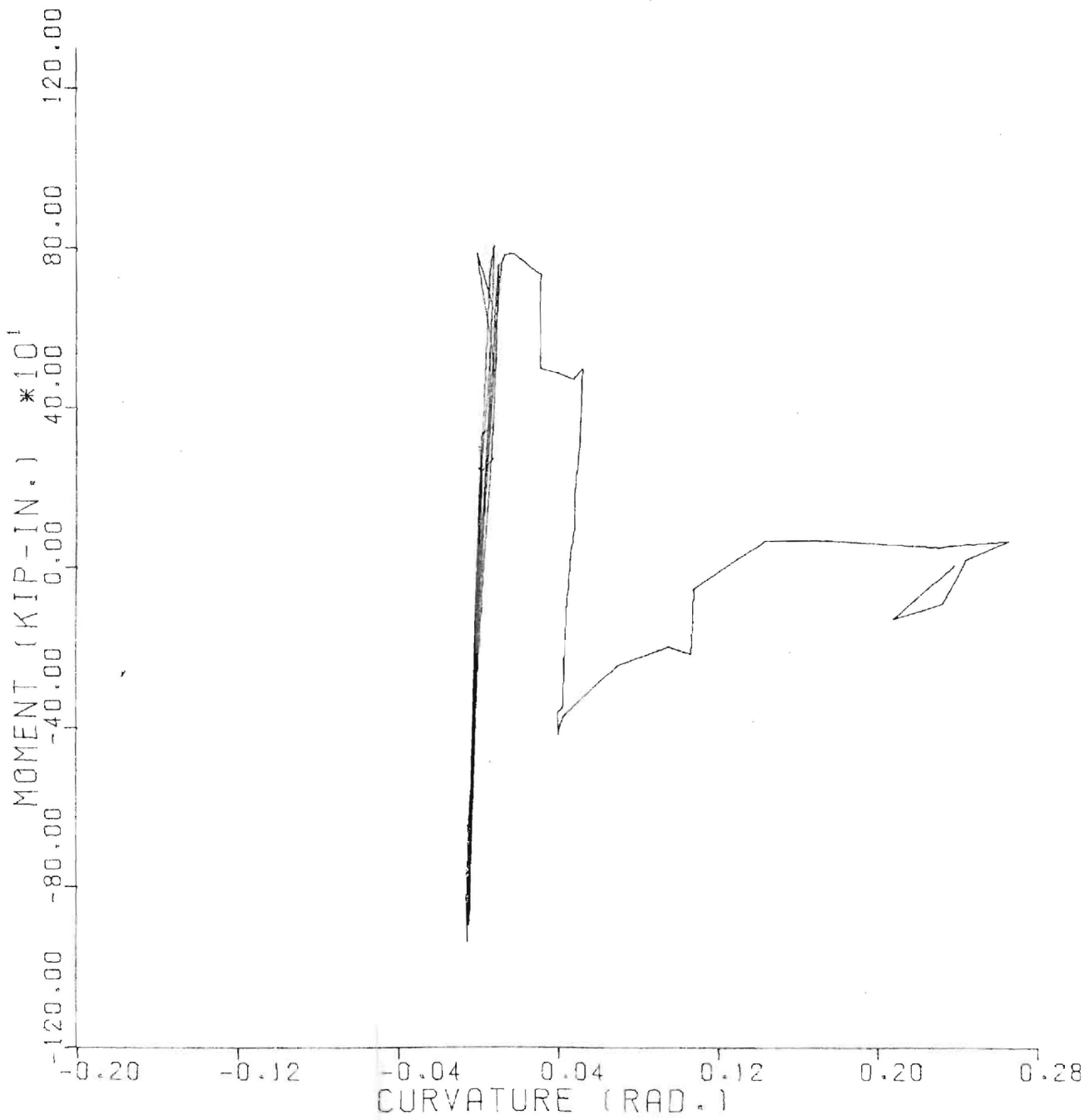

Figure 3.13 Specimen 1, moment-curvature response.

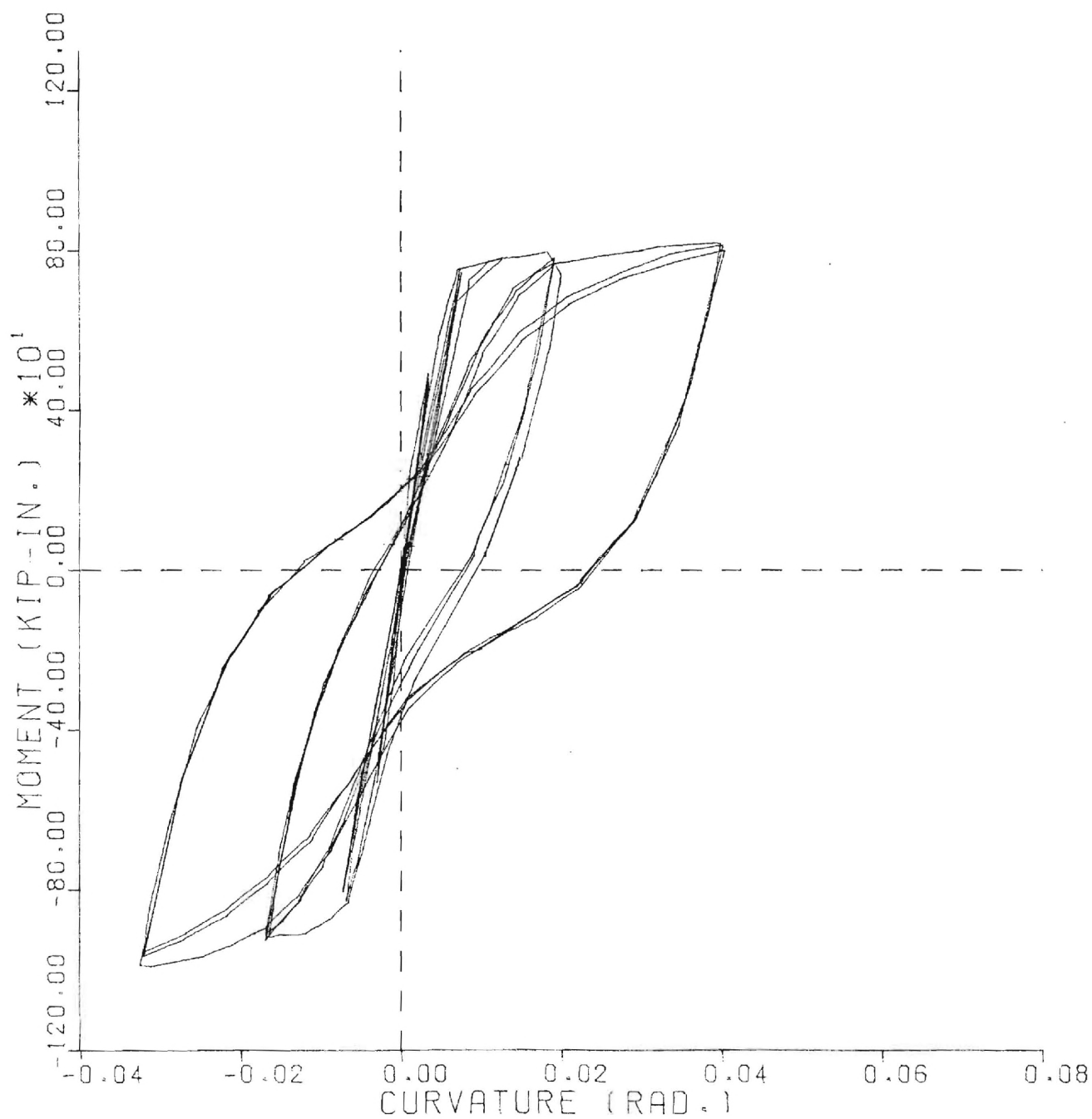

Figure 3.14 Specimen 2, moment-curvature response.

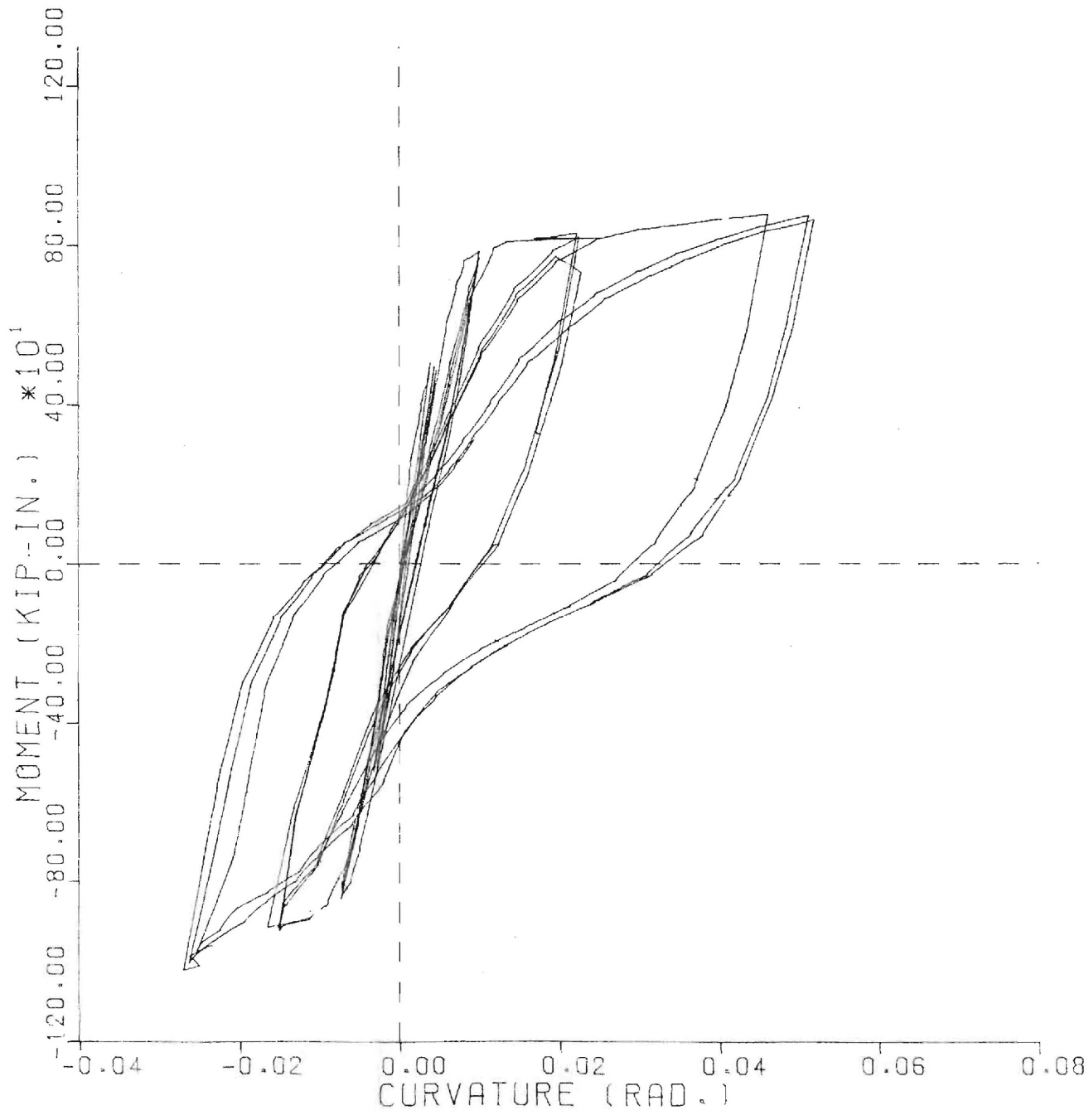

Figure 3.15 Specimen 3, moment-curvature response.

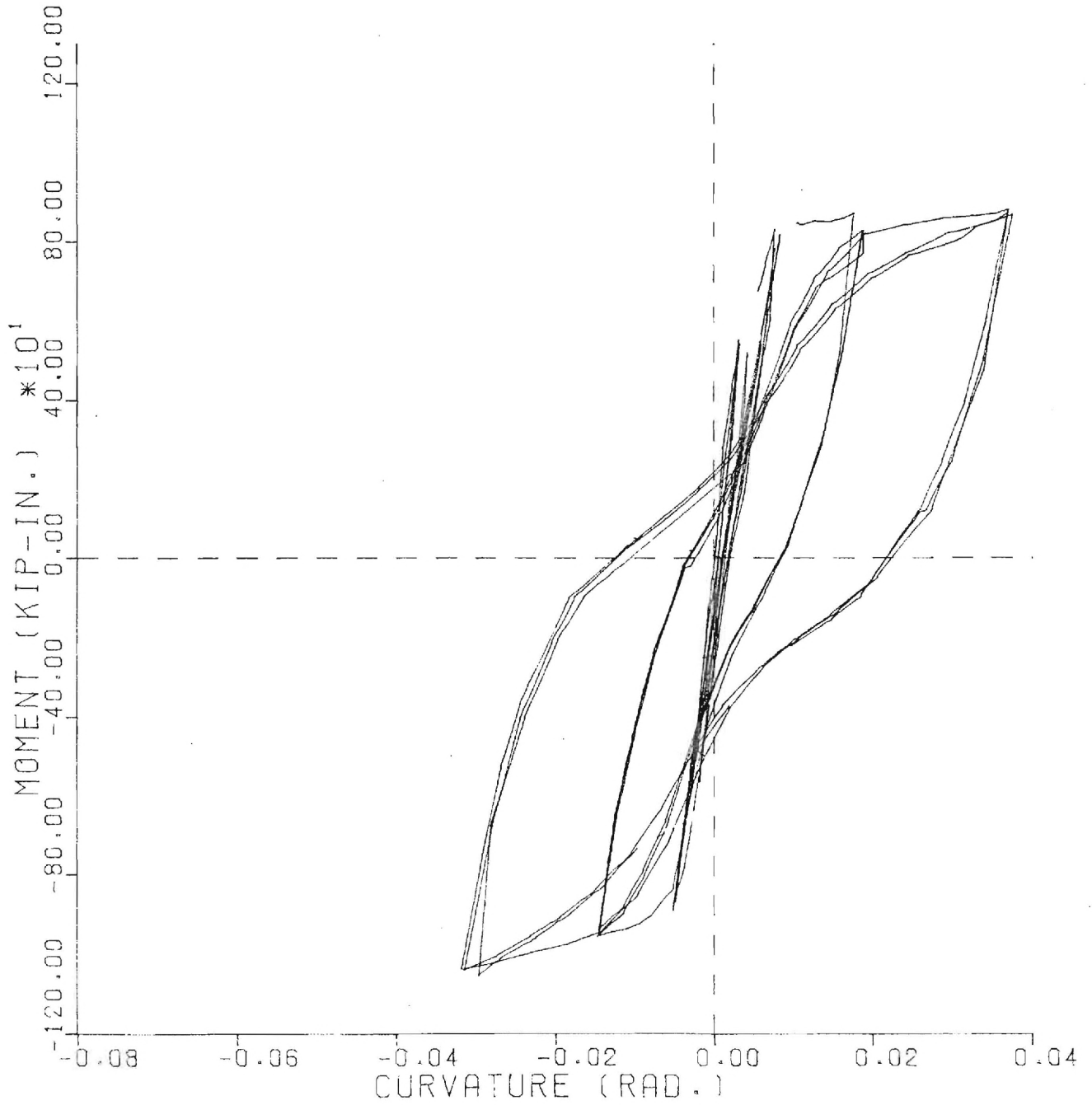

Figure 3.16 Specimen 4, moment-curvature response.

plot for Specimen 1 shows almost immediate failure at curvatures beyond the elastic range. The most important observation in the plots for Specimens 2, 3 and 4 is that the moment continued to increase at curvatures between 0.02 radian and 0.04 radian during the first cycle to the maximum deflection. This increasing moment corresponds to the decreasing lateral load at large deflections mentioned in Section 3.1 above. Although the P- $\Delta$  effect was evident, the moment capacity of the columns was stable and slightly increasing.

### 3.4 Strain Observations

The majority of strain observations have been omitted from this report because they shed little insight into the behavior of the strengthening techniques. Figures 3.17 through 3.20 show the average strain on the bottom No. 7 bars where the gages were located 1 in. from the joint. Only data for the first cycles to  $\frac{1}{2}\Delta y$ ,  $\Delta y$  and  $2\Delta y$  were included for clarity. Figures 3.21 and 3.22 show the strain on the packaging band and U-clamps respectively.

For all specimens the maximum recorded tensile strain on the #4 gage wire tie located 1 in. from the joint was about 1000 micro-inch/inch. This represents a stress less than one-half the yield stress of the ties. Crack patterns in Specimens 1 and 4 indicated that the strain in the second tie located 11-in. from the joint would have been much greater than in the tie next to the joint. It was the second tie that unraveled when Specimen 1 failed. Unfortunately, the second tie was not instrumented.

The band next to the joint in Specimen 2 and the U-clamp next to the joint in Specimen 4 were instrumented with strain gages. For the band the maximum tensile strain readings was less than 300 micro-inch/inch in the deflection cycles to  $\Delta y$ ,  $2\Delta y$ , and  $4\Delta y$ . This low strain represented a stress less than 9000 psi in the band. For the U-clamp the maximum tensile strain was less than 30 micro-inch/inch, a stress less than 1000 psi. These stresses represent forces in the band of about 800 lbs and in the U-clamp of about 600 lbs.

The crack pattern shown in Figure 3.10 indicated that the strain in the second U-clamp from the joint would have been larger than the



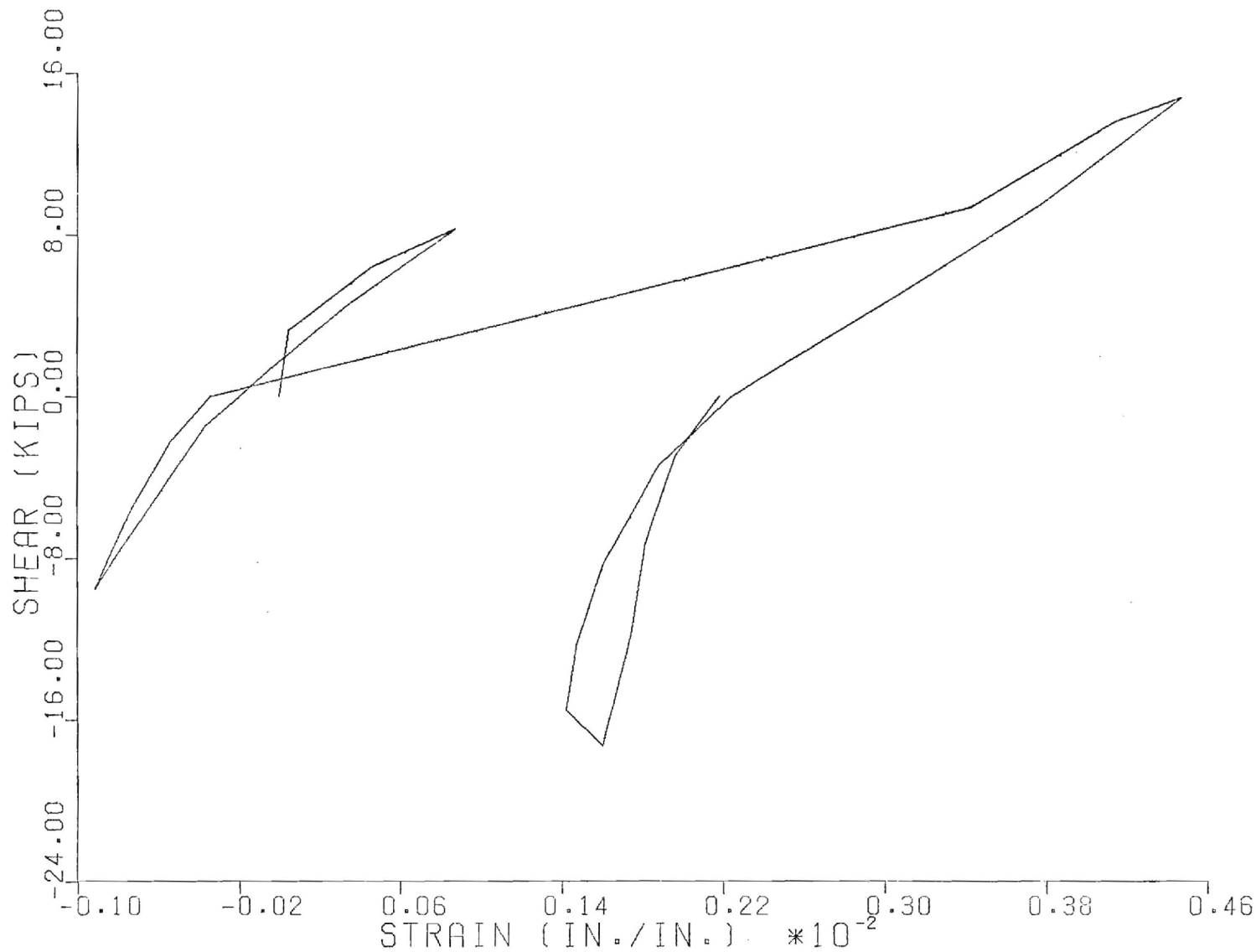

Figure 3.17 Specimen 1, average strain on bottom No. 7 bars, 1-in. from joint for deflection cycles 1 and 4.

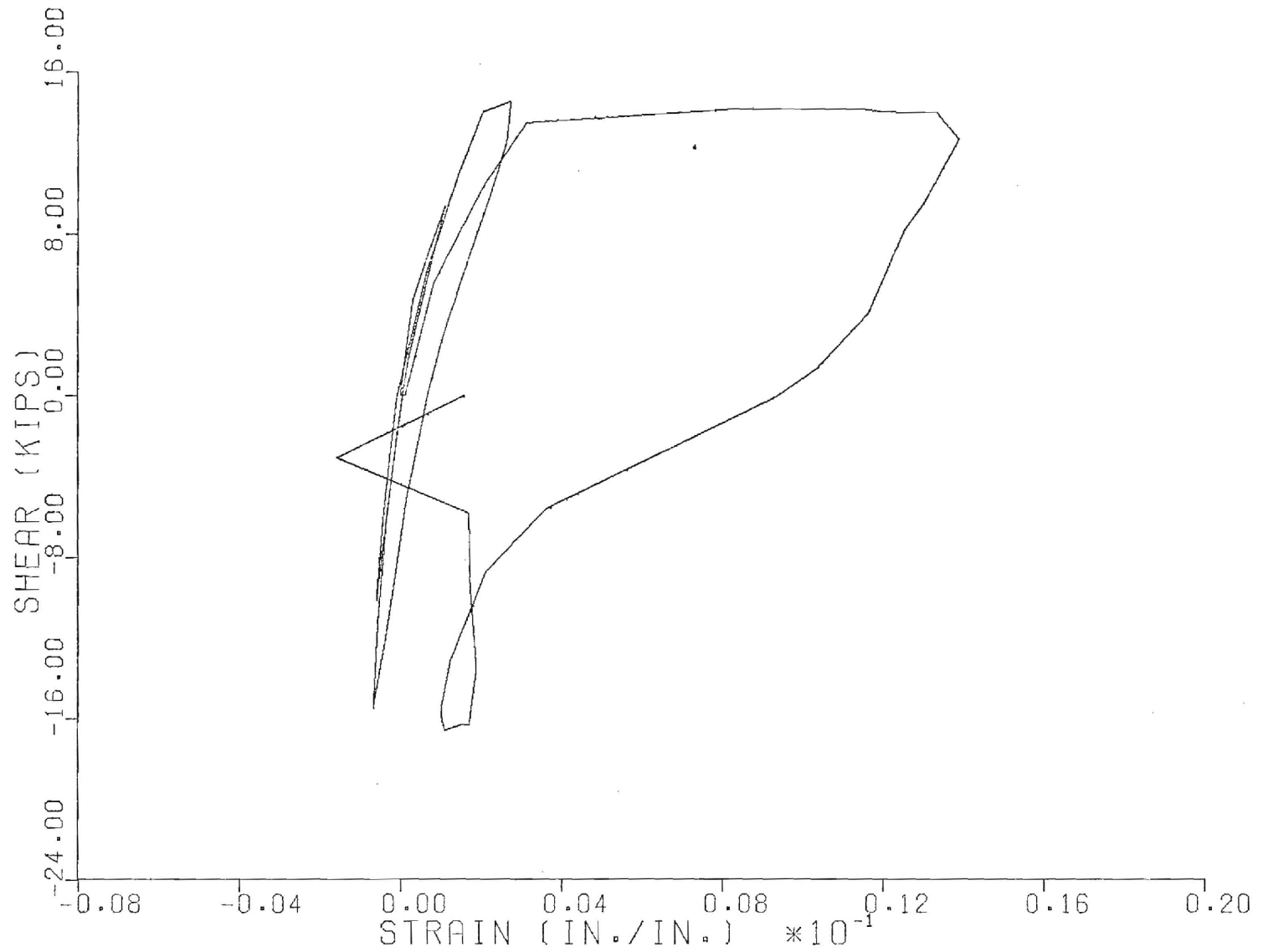

Figure 3.18 Specimen 2, average strain on bottom No. 7 bars, 1-in. from joint for deflection cycles 1, 4, and 7.

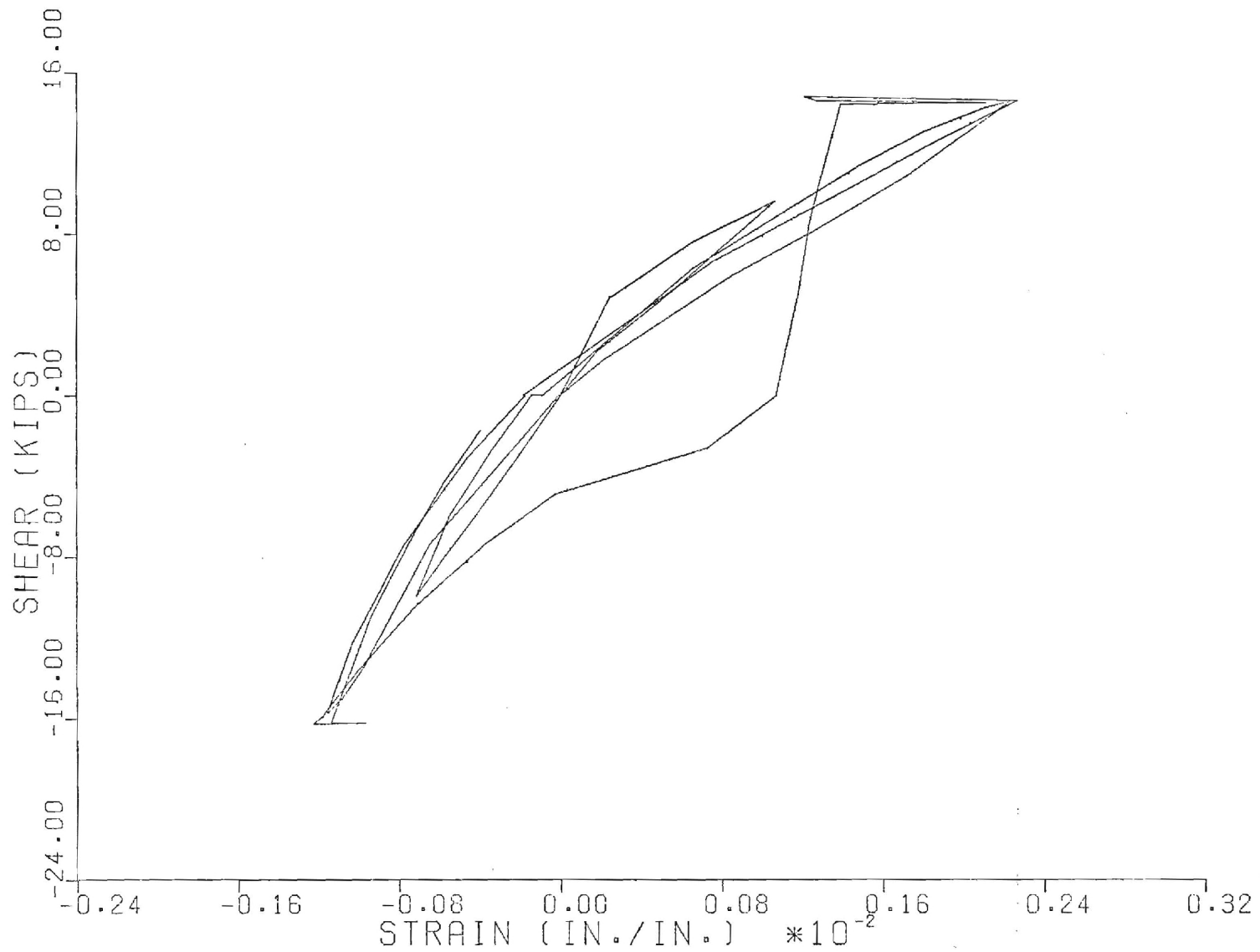

Figure 3.19 Specimen 3, average strain on bottom No. 7 bars, 1-in. from joint for deflection cycles 1, 4, and 7.

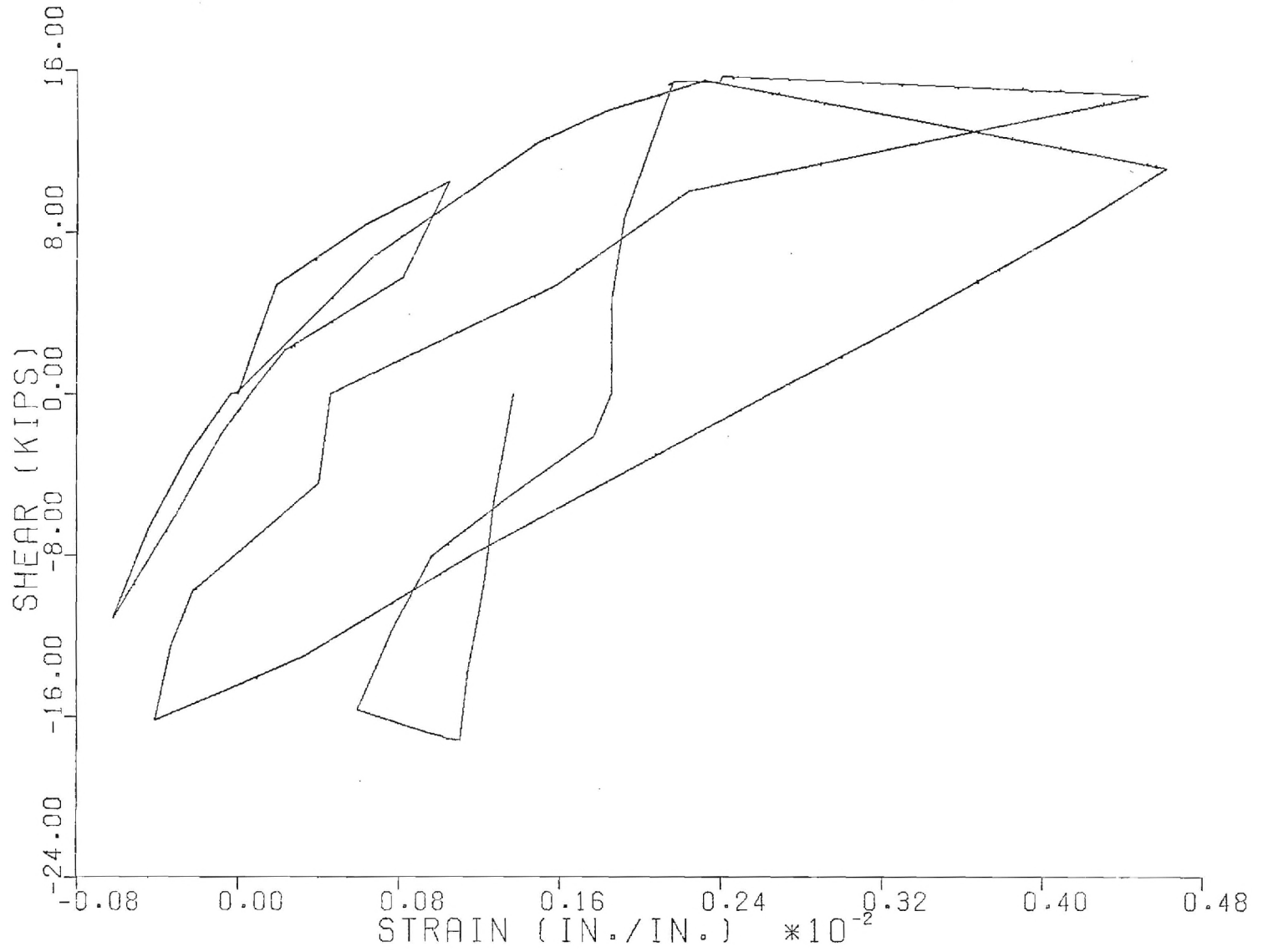

Figure 3.20 Specimen 4, average strain on bottom No. 7 bars, 1-in. from joint for deflection cycles 1, 4, and 7.

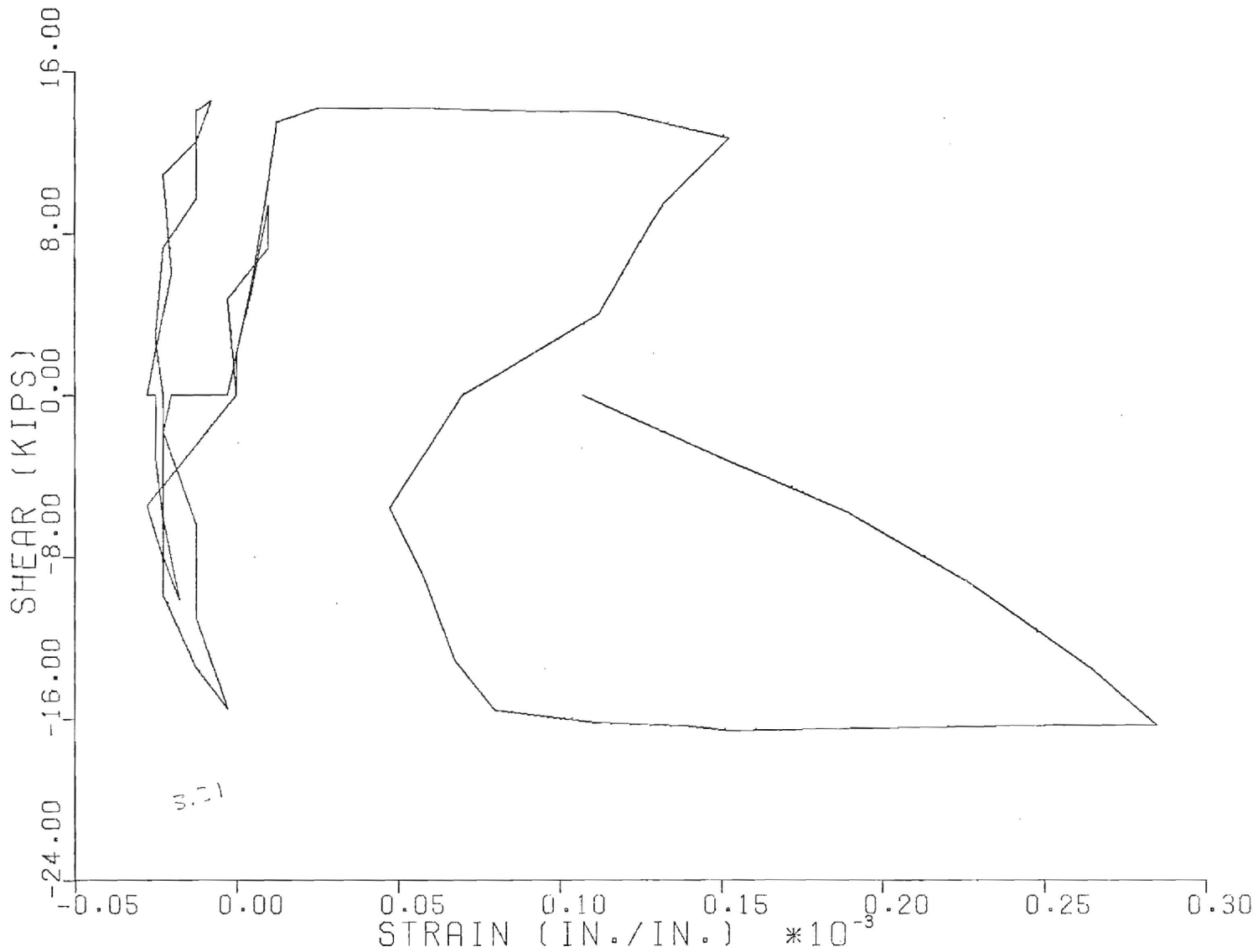

Figure 3.21 Specimen 2, strain on packaging band next to joint for deflection cycles 1, 4, and 7.



Figure 3.22 Specimen 4, strain on U-clamp next to joint for deflection cycles 1, 4, and 7.

strain in the first U-clamp. Observations of the second U-clamp and bolt did not indicate any yielding. The second clamp had added flexibility across the crack because of the bending of the outstanding legs. The bending of these legs reduced the stiffness and effective confining capacity of the clamp.

### 3.5 Energy Dissipation

The energy dissipated by each column in each deflection cycle was determined by measuring the area within the hysteresis loops of the shear force - deflection curves, Figures 3.1 through 3.4. The cumulative dissipated energy for the four specimens is shown in Figure 3.23. Specimens 2, 3 and 4 absorbed and dissipated similar amounts. The differences resulted because the deflection magnitudes at  $2-\Delta y$  and  $4-\Delta y$  for each specimen were slightly different. Specimen 1 dissipated an order of magnitude less energy than the strengthened columns.



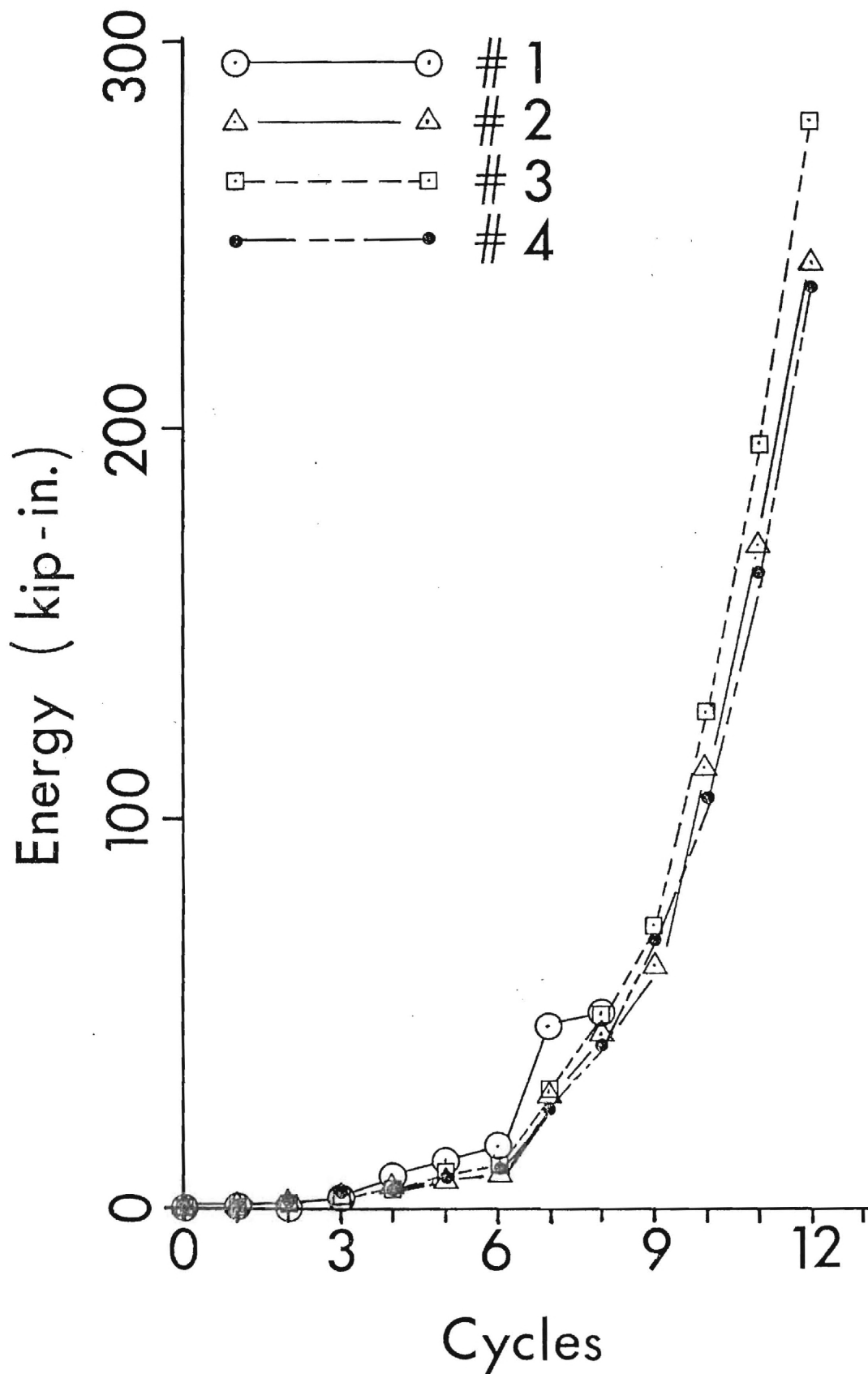

Figure 3.23 Cumulative dissipated energy.

## 4. DISCUSSION

### 4.1 Quantitative Analysis

#### 4.1.1 Moment Capacity

Using standard principles of reinforced concrete analysis without any capacity reduction factors, the ultimate moments ( $M_u$ ) of the specimens were calculated and were listed in Table 4.1 together with the maximum observed moments. The observed maximums were all greater than the calculated  $M_u$  values. For the strengthened specimens, the average of positive and negative maximum moments was 18 percent greater than the calculated  $M_u$ . The author believes this significant increase in moment capacity resulted from the confining effect of the bands or spiral. Not only would the strength of the concrete be increased by biaxial effects, but the ultimate strain of the concrete would also be increased. The increase in concrete strain capacity allowed rotations which brought the tension steel into the strain hardening region. The rise in steel stress above the yield value resulted in the higher moments observed.

Table 4.1 Moment Capacities

Specimen	Calculated $M_u$ (inch - kips)	Observed $M_u$ (inch-kips)	
		Positive	Negative
1	798	+ 800	- 940
2	799	+ 820	- 1000
3	798	+ 870	- 1030
4	799	+ 880	- 1060

#### 4.1.2 Confinement and Shear

The ultimate shear capacity provided by the concrete ( $V_c$ ) was calculated by the provisions in ACI 318-77 (3), and the values are listed in Table 4.2. Also listed are the calculated ultimate capacities

Table 4.2 Shear and Confinement

Specimen/Technique	$V_c$ (kips)	$V_s$ (kips)	$V_{max}$ average (kips)	$A_{sh}$ required (sq. in.)	$A_{sh}$ actual (sq. in.)	$\frac{A_{sh} \text{ actual}}{A_{sh} \text{ req'd}}$
1. None	13.5		16.0	-	-	-
2. Packaging Bands	13.6	33.4	15.5	0.18	0.09	0.51
3. #2 Spiral	13.5	49.8	15.6	0.07	0.05	0.78
4. U-clamp	13.6	104.9	16.5	0.39	0.63	1.61

of shear resistance provided by the various strengthening techniques ( $V_s$ ) and the average of positive and negative observed shear values ( $V_{max}$ ). As the author had anticipated from previous research (16), Specimen 1 sustained a shear force 18 percent greater than that calculated using code provisions (3). But once shear failure occurred, Specimen 1 collapsed.

Table 4.2 shows that all the observed  $V_{max}$  values were about 17 percent greater than the calculated  $V_c$  value. These  $V_{max}$  values imply that the shears on Specimens 2, 3 and 4 were about equal to the ultimate shear capacity of the concrete.

But Specimens 2, 3 and 4 possessed extensive reserve shear strength provided by the wrappings. The shear resistance of the wrappings was not utilized. The strain data indicated less than 9000 psi stress in the packaging band and 1000 psi in the U-clamps next to the joint. The minor diagonal cracks beneath the second band and the second U-clamp indicated higher strains in those wrappings than in the ones nearest the joint. But the stress in the first band of Specimen 2 would have been substantial, over 43 ksi\*, if the bands were required to carry the total shear force,  $V_{max}$ . That the stress in the band was less than 21 percent of this value showed that the shear forces were resisted principally by the concrete, even at the  $4-\Delta y$  deflection level.

The confinement provided by the strengthening techniques allowed the concrete to resist shear over the large deflection cycles. In Specimen 1 as the compression concrete spalled (Figure 3.6), the shear carried by the compression zone ( $V_{cz}$ , Reference 16) deteriorated rapidly. With the opening of the diagonal crack, shear transmitted by aggregate interlock ( $V_a$ ) decreased. The result was rapid loss of all shear resistance. In Specimens 2, 3 and 4 the wrapping nearest the joint prevented spalling; the concrete in the compression zone resisted shear forces. The wrapping away from the joint prevented the diagonal crack from opening so that  $V_a$  was maintained.

The quantity of confining ties needed in reinforced concrete

---

\*  $V_{max}$  for Specimen 2 = 43  
 (2 bands) (.18 in<sup>2</sup>/band) (29,000 ksi)

columns was given in ACI 318-77 Appendix A (3) as the following

$$A_{sh} = \frac{l_h \rho_s s_h}{2}$$

where  $A_{sh}$  = area of transverse hoop bar (one leg), in.<sup>2</sup>

$l_h$  = maximum unsupported length of rectangular hoop. In this case  $l_h$  was taken as 10 in., the column dimension.

$s_h$  = center-to-center spacing of hoops which was 4.0 in. for the bands, 1.1 in. for the No. 2 spiral, and 4.25 in. for the U-clamp.

$$\rho_s = 0.45 \left( \frac{A_g}{A_{ch}} - 1 \right) \frac{f'_c}{f_y}$$

but not less than

$$0.12 \frac{f'_c}{f_y}$$

$A_g$  = gross area of section, which was 100 in.<sup>2</sup>

$A_{ch}$  = area of rectangular core of column measured out-to-out of hoop which was taken as  $A_g$  for Specimens 2, 3 and 4.

Because  $A_g$  and  $A_{ch}$  were the same for the strengthened columns, the minimum provisions governed for the amount of externally applied hoops. The calculated values for  $A_{sh}$  are given in Table 4.2, along with the values of  $A_{sh}$  actually provided. The value of  $f_y$  used for the packaging bands was that determined by the slip of the bands through the clips rather than the higher value of the actual yield stress of the steel (Chapter 2).

The ratio of the  $A_{sh}$  provided to the  $A_{sh}$  required by ACI 318-77 is shown in the last column of Table 4.2. As discussed in Chapter 2, the author specifically designed the strengthening techniques to provide a range of  $A_{sh}$  from less than to greater than that required. The exact ratio was tempered by constructability and judgement of appropriate hoop spacing that might be used in actual retrofit practice.

Whether the strengthening techniques provided about 50 percent (Specimen 2) or 160 percent (Specimen 4) of the  $A_{sh}$  required did not affect the elastic or inelastic response of the columns. As shown by the load-deflection hysteresis curves and by the dissipated energy plots, the responses of Specimens 2, 3 and 4 were almost identical. The author concluded that the ACI provisions (3) for  $A_{sh}$  required for confinement were too conservative. Less  $A_{sh}$  may be used to provide confinement as

demonstrated by Specimens 2 and 3.

It must be remembered that these strengthening techniques confined the whole column and not just the core area bordered by the main reinforcement. Typical hoops used for new construction would confine only the core area. An explanation for the fact that less than the required  $A_{sh}$  satisfactorily confined the concrete is that by confining the compression zone the wrappings permitted  $V_{cz}$  to be effective and increased the failure strain of the concrete. Confining hoops within a column only act after the cover has spalled and when the column has a much reduced section. The area of hoops ( $A_{sh}$  required) are then designed to provide the strength lost by the spalling (16). The strengthening techniques do not need to provide for lost material. Therefore, the requirements for confinement related to exterior strengthening of existing columns is different than the need for confinement in new designs.

Furthermore, the rectangular spiral of Specimen 3 utilized plain No. 2 bar. The current code (3) requires that the minimum size hoop be a No. 3 bar. The No. 2 spiral performed well; no bulging was noticed. For columns larger than 10 in. x 10 in., a larger diameter bar may be required; but for the small size column tested, the  $\frac{1}{4}$ -in. diameter bar for the spiral was satisfactory.

From the above the author concluded that the requirements in ACI 318-77 are not directly applicable to retrofit of existing structures. Modified requirements for repair and strengthening are needed.

#### 4.2 Qualitative Analysis

The two most significant qualitative results were the following: (1) the three strengthening techniques greatly improved the ductility and cyclic resistance of the existing reinforced concrete columns, and (2) the various types of strengthening used, even though providing different amounts of steel ( $A_{sh}$ ), produced the same ductile type of structural behavior.

The term ductility used herein means the ability of the column to sustain axial load and a lateral force through increased lateral deformations and to absorb and dissipate energy over reversed, in-

elastic deflection cycles. The strengthened columns demonstrated much greater ductility than the unstrengthened column. The response of Specimens 2, 3 and 4 is that desired for earthquake resistance, for it sustains lateral loads over inelastic deformations and dissipates seismic energy without severe structural degradation.

Because the type of strengthening did not affect the ductile response, the choice of strengthening technique would depend upon constructability, ease of application in an occupied building and cost. This research did not investigate all possible strengthening techniques nor the cost of large scale application of the three types studied. But the author did gain an appreciation for the construction of each.

The U-clamp technique was the easiest to apply to the column and would be the cleanest to work with in an occupied building. Fabricating the U-clamps in the machine shop required considerable time, and in actual application this fabrication would be more expensive than the banding technique (Specimen 2). But the shop-time was compensated for by the short time required in the field bolting application of the clamps.

The packaging bands were applied easily to Specimen 2, but such banding would be slightly more difficult to a column in a vertical orientation. Grouting beneath the bands was the time consuming part of the construction. Such dry-pack work would be somewhat messy in an existing structure. From the observations made during the test, the author believes that the grouting under the bands was necessary to provide confinement.

The rectangular spiral was the most difficult to apply. The wrapping and plastering would create more disturbance in an occupied structure than created by the other two techniques. Use of larger than the  $\frac{1}{4}$ -in. diameter rod would make fabricating the rectangular spiral difficult. If provisions of ACI 318-77 were followed, a No. 3 bar would be the minimum size required.

Use of any of the techniques seems to provide an economic alternative to placing No. 3 or No. 4 hoops around the column and casting concrete or applying shotcrete. Shotcrete and cast-in-place concrete disrupt the use of an occupied structure and require extensive clean-up.



After application of any strengthening technique, the column would be covered with an architectural finish or surrounded with gypsum board or paneling.

#### 4.3 Limits of Findings

While the findings of this research do point to use of low cost techniques for strengthening existing columns, the results are quite limited in scope and must be applied with judgement. The three techniques worked well on the 10-in. x 10-in. column with corner reinforcement. For larger size columns with intermediate reinforcement along the sides, the external confining system would have to resist greater bulging forces. The requirement (3) that intermediate bars be restrained by supplementary crossties could not be satisfied by exterior wrappings only.

The techniques increased the ductility of the columns and, thereby, provided a strengthening effect at large deflections and over repeated loading cycles. But the systems did not increase the maximum lateral load carried by the columns. The author believes that increasing ductility is primary in improving the earthquake resistance of existing structures, but increasing the lateral load resistance sometimes is required. These techniques would not accomplish the latter.

By strengthening a column with any of the techniques, the failure zone of the existing structural system may be shifted from the column into the beam-column connection. Most existing structures outside California lack the special stirrup-ties in the joint required for ductile performance. Beams framing into a joint help confine the joint (7, 13), and column strengthening may not necessarily lead to joint failure. But the designer must be cautious and not assume that by strengthening one structural component he has strengthened the entire system.

Each existing structure is unique, and a retrofit technique for improving earthquake resistance must be engineered especially for that structure. Application of the concepts experimentally tested in this research must be applied with careful judgement for each specific condition.

## 5. CONCLUSIONS AND RECOMMENDATIONS

Four identical reinforced concrete columns were constructed, and three were strengthened using various techniques, packaging bands, No. 2 bar spiral, and U-clamps. Each technique greatly improved the ductility and, therefore, the earthquake resistance of the existing columns. The unstrengthened column collapsed at a deflection ductility ratio less than two, while the strengthened columns resisted three cycles of lateral deformations to ductility ratios of four with little deterioration. Although the three techniques provided different areas of confining steel, the responses of the three strengthened columns were the same.

Both the packaging bands and No. 2 bar spiral provided significantly less transverse reinforcement than required by ACI 318-77 (3); yet the columns behaved satisfactorily. It was concluded that for the retrofit of existing structures, the building code provisions used for new construction may be too conservative.

The application of any strengthening technique will depend on its ease of construction within an occupied structure. The shop-fabricated U-clamps were easiest to install on the column and would require the least disturbance to building occupants. The banding simply was tightened around the column. Grouting beneath the bands was required for confinement; such grouting would be time consuming and messy but would not present excessive difficulties. The rectangular spiral was most difficult to construct. Both the U-clamp and banding techniques show significant potential for strengthening of existing columns and tentatively are recommended.

The use of these techniques should be limited to small columns like those tested for this research. Further research is necessary to investigate other parameters such as column size, reinforcing bar location, axial load, hoop size and spacing, and concrete strength. Nevertheless, this research has demonstrated that simple, low-cost, easy-to-construct techniques may be used to greatly increase the ductility and improve the earthquake resistance of existing reinforced concrete columns.

APPENDIX  
MATERIAL TESTS

by William E. Bynum, III

A.1 Reinforcing Bars

Several methods and combinations of methods were employed to measure and record strain during tensile tests of reinforcing steel specimens. The techniques used were bonded electrical resistance strain gages, inscribed gage marks, an LVDT extensometer with automatic graphing. The No. 7, No. 4 and No. 3 bars were loaded with Tinius-Olsen Universal Testing Machine, while the No. 2 bars were tested with an Instron Testing Machine. Material properties for each reinforcing bar size were computed and are listed in Table A.1. The yield stress for each bar was found by using the ASTM accepted 0.2 percent offset method.

Two No. 7 bar specimens were strain gaged to create a half Wheatstone bridge resistance unit. Two gages, diametrically opposed, were oriented along the axis of the bar at a single location. By electronically averaging the strains, bending strains were canceled. The bars also were inscribed with two marks, approximately two inches apart, near the strain gages. The strain gages responded until a strain of about .012 inches per inch, at which time the bond failed. Deformation readings then were taken up to fracture with calipers positioned between the inscribed marks. This two step procedure is not recognized by the ASTM, but was adopted for No. 7 bar testing for two reasons: first, the use of strain gages during elastic behavior would give a more accurate determination of the yield point, and second, the No. 7 bars in the column prototypes were strain gaged, so the material test specimens were gaged similarly for uniformity. Figure A.1 is the average stress-strain curve plotted with data from the two tests. The specimens exhibited ductility and large plastic deformation prior to rupture which is reflected by the cup-cone type fracture in Figure A.2. The stress and strain results show that the No. 7 bars meet specifications for a 615 Grade 40 reinforcing steel.

TABLE A.1

## Material Properties for Reinforcing Bars

Bar Size	Yield Stress (ksi)	Ultimate Stress (ksi)	Ultimate Strain (in/in)	Modulus of Elasticity (ksi)
No. 7**	56.80	92.33	.158	29,200
No. 4***	64.30	95.00	.157	28,100
No. 3*	63.10	94.09		31,000
No. 2**	77.90	82.38	.022	29,800

\* Average 1 Test  
\*\* Average 2 Tests  
\*\*\* Average 3 Tests

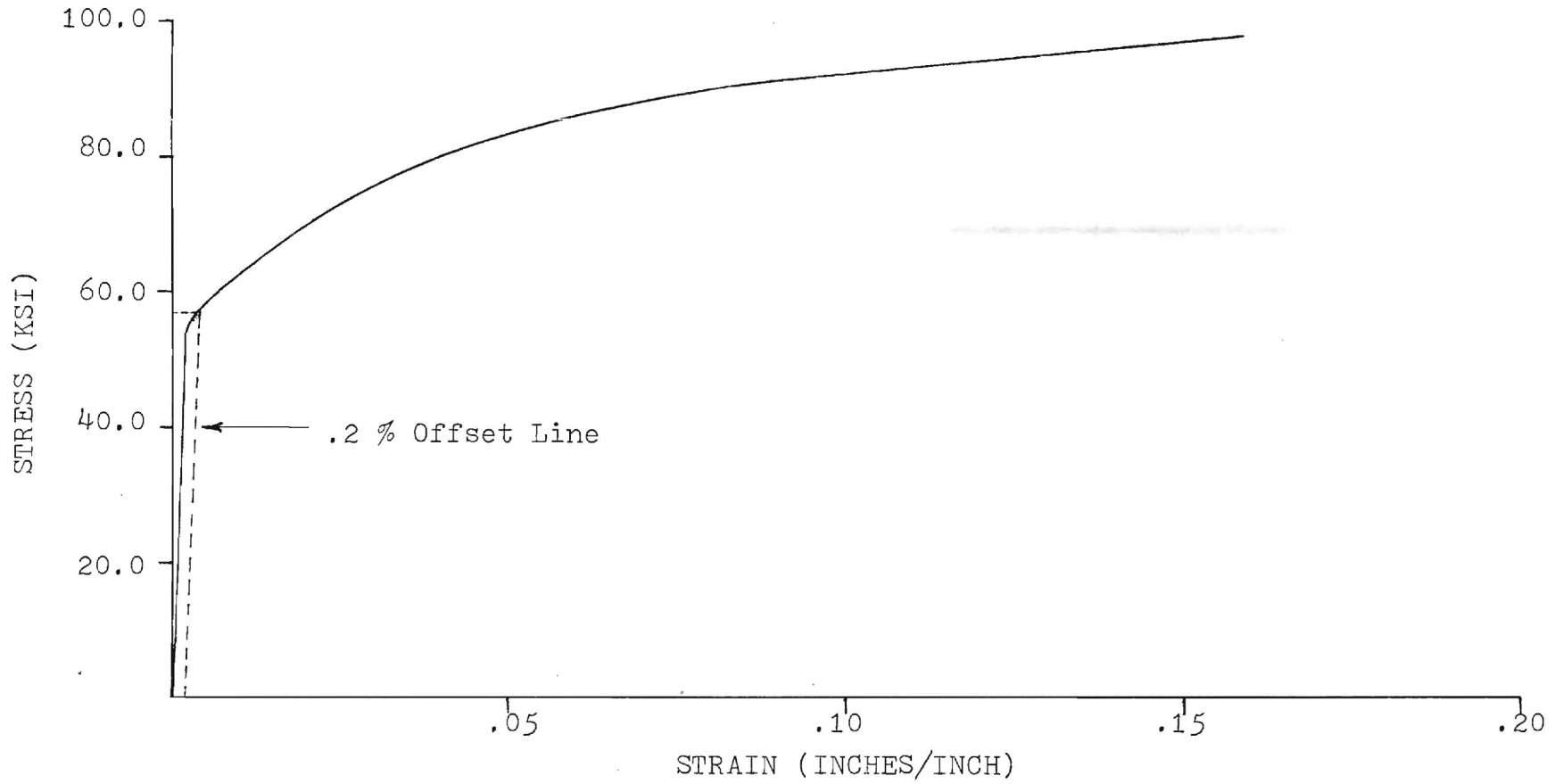
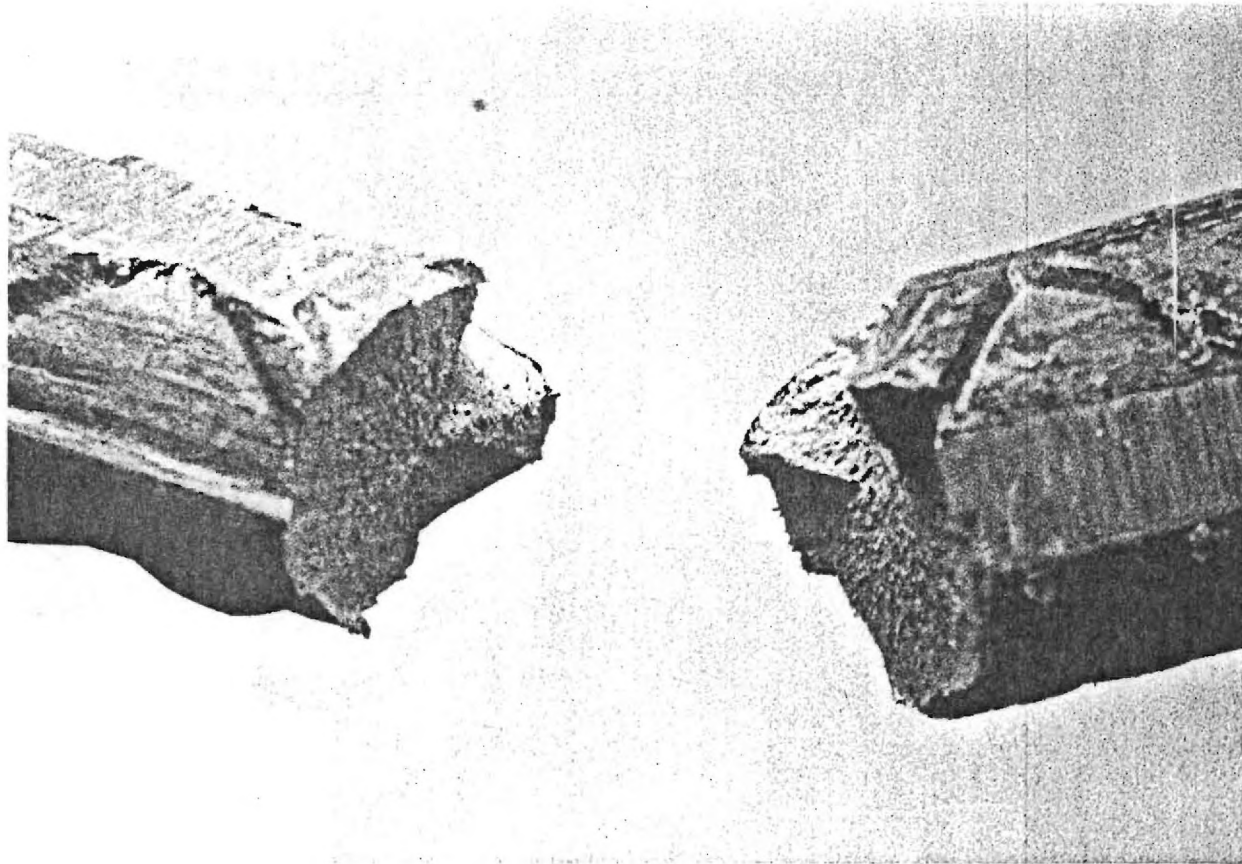

Figure A.1 - Average Stress-Strain Curve for No. 7 Reinforcing Steel Bar



---

Figure A.2 - Cup-Cone Fracture of No. 7 Reinforcing Bar Specimen

Three No. 4 bar specimens were tested using a Tinius-Olsen autographic plotter together with an LVDT extensometer of two-inch gage length to plot load-strain curves up to a strain of approximately .005 inches per inch. After yielding, readings were taken with calipers positioned between two marks, initially inscribed eight inches apart. Both techniques used for recording No. 4 bar strain measurements are ASTM approved methods. The average stress-strain curve derived from data of each of the three specimens is given in Figure A.3. The cup-cone fracture of one of the specimens is shown in Figure A.4. The stress and strain results show that the No. 4 bars meant specifications for A 615 Grade 60 reinforcing steel.

Two No. 3 bars were tested using one electrical resistance strain gage oriented along the length of the bar. Strain was recorded as the bars were loaded to fracture. Inscribed gage marks were not used. One of the specimens gave unreasonable results; the modulus of elasticity was found to be 46,000 ksi, an obvious error. Possible explanations were unsymmetric tensioning of the bar or load indication errors of the testing machine. Following ASTM recommendations this specimen was disregarded, and all material properties for the No. 3 bars were based on a single specimen and were found to meet ASTM specifications for A 615 Grade 60 reinforcing steel. The resulting stress-strain curve is shown in Figure A.5. Excellent ductile behavior was exhibited as illustrated by its fracture shown in Figure A.6.

The Instron Testing Machine, complete with an ASTM accepted autographic plotter, was employed to test the two No. 2 reinforcing bars. An electrical resistance strain gage extensometer (one-inch gage length) was clipped to the bar and was electrically connected to the plotter. The load-elongation graphs produced by the plotter were averaged and transformed into the stress-strain curve presented in Figure A.7. Extreme necking occurred in the bars prior to rupture as shown in Figure A.8. From ASTM specifications, the bars were found to meet A 615 Grade 40 reinforcing steel.

## A.2 Concrete Cylinders

ASTM approved 28 day compressive strength and split tensile



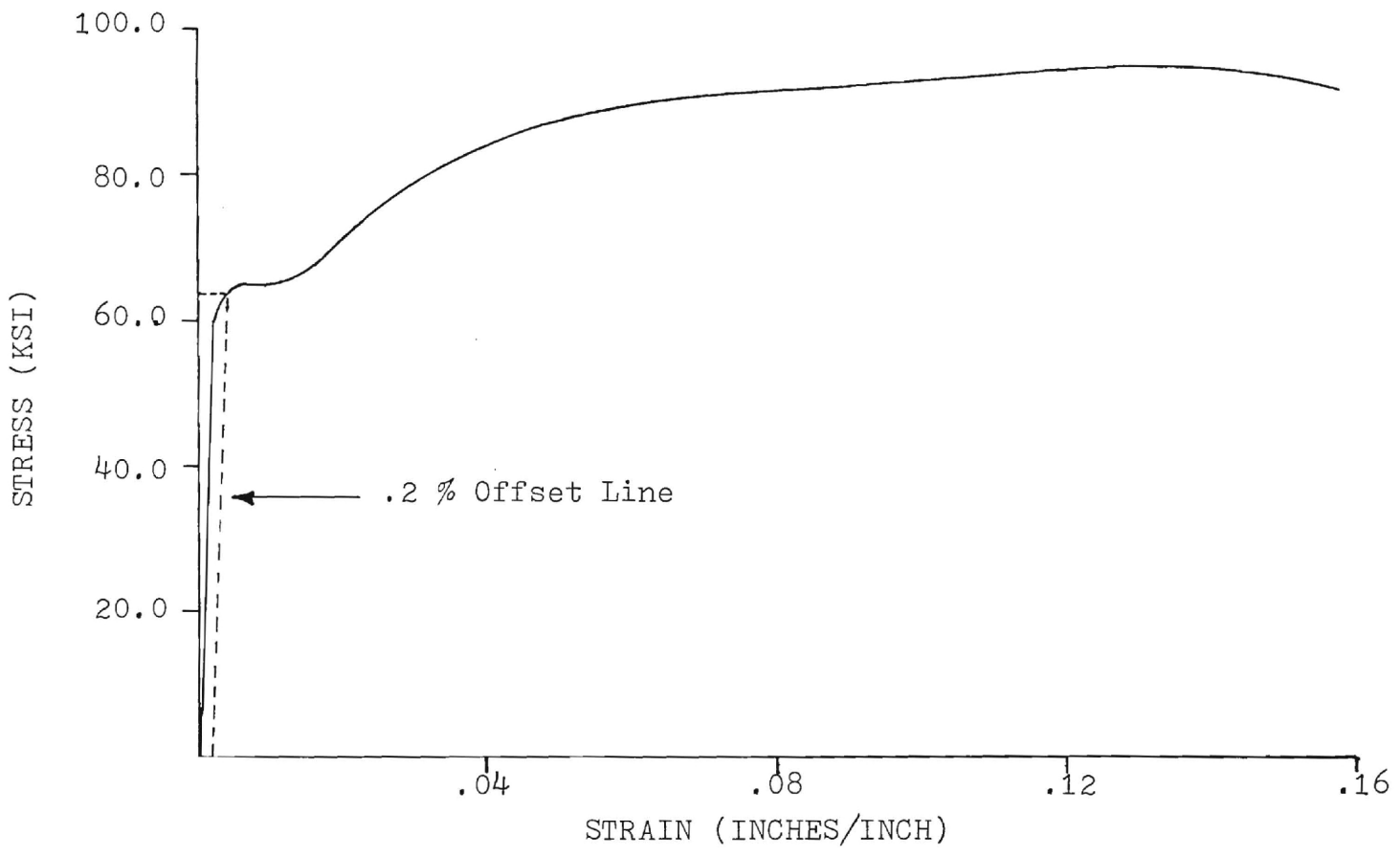

Figure A.3 - Average Stress-Strain Curve for No. 4 Reinforcing Steel Bar

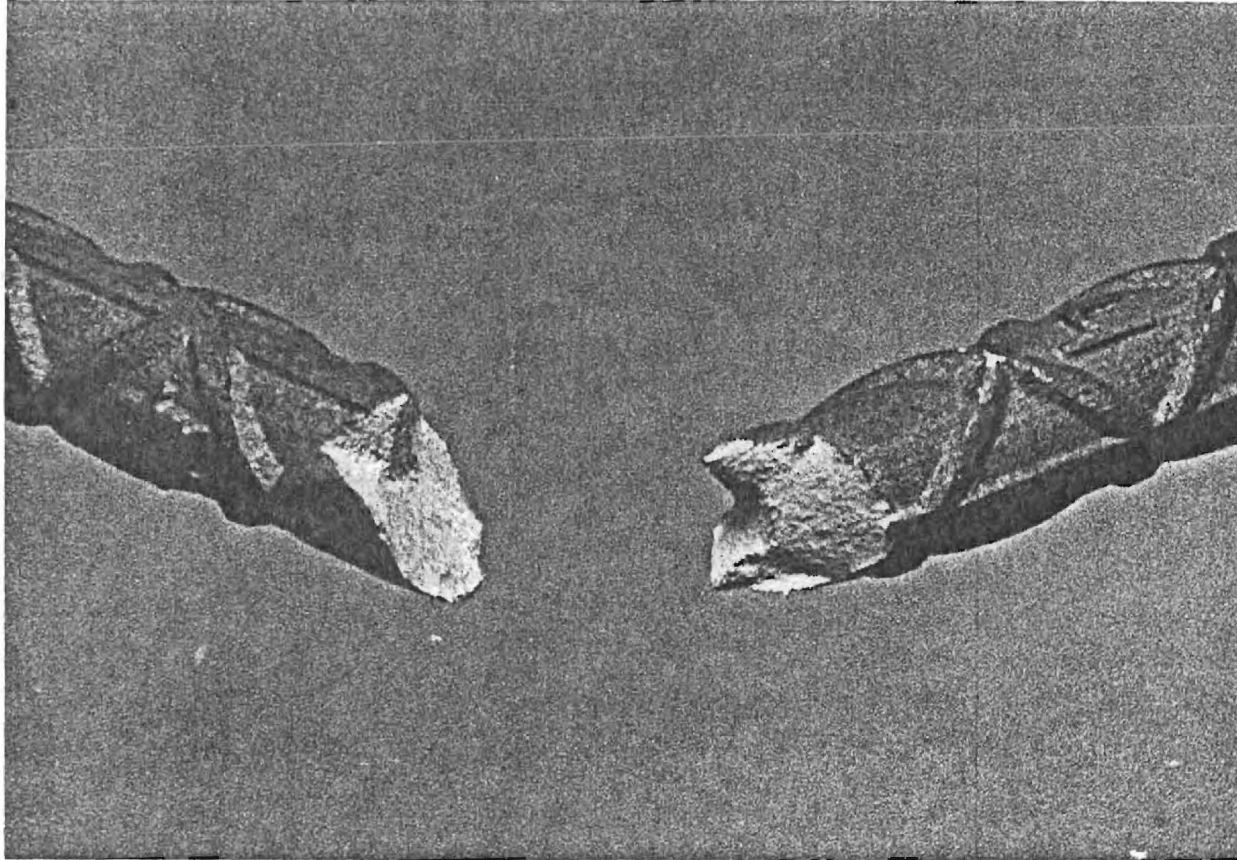

Figure A.4 - Cup-Cone Fracture of No. 4 Reinforcing Bar Specimen

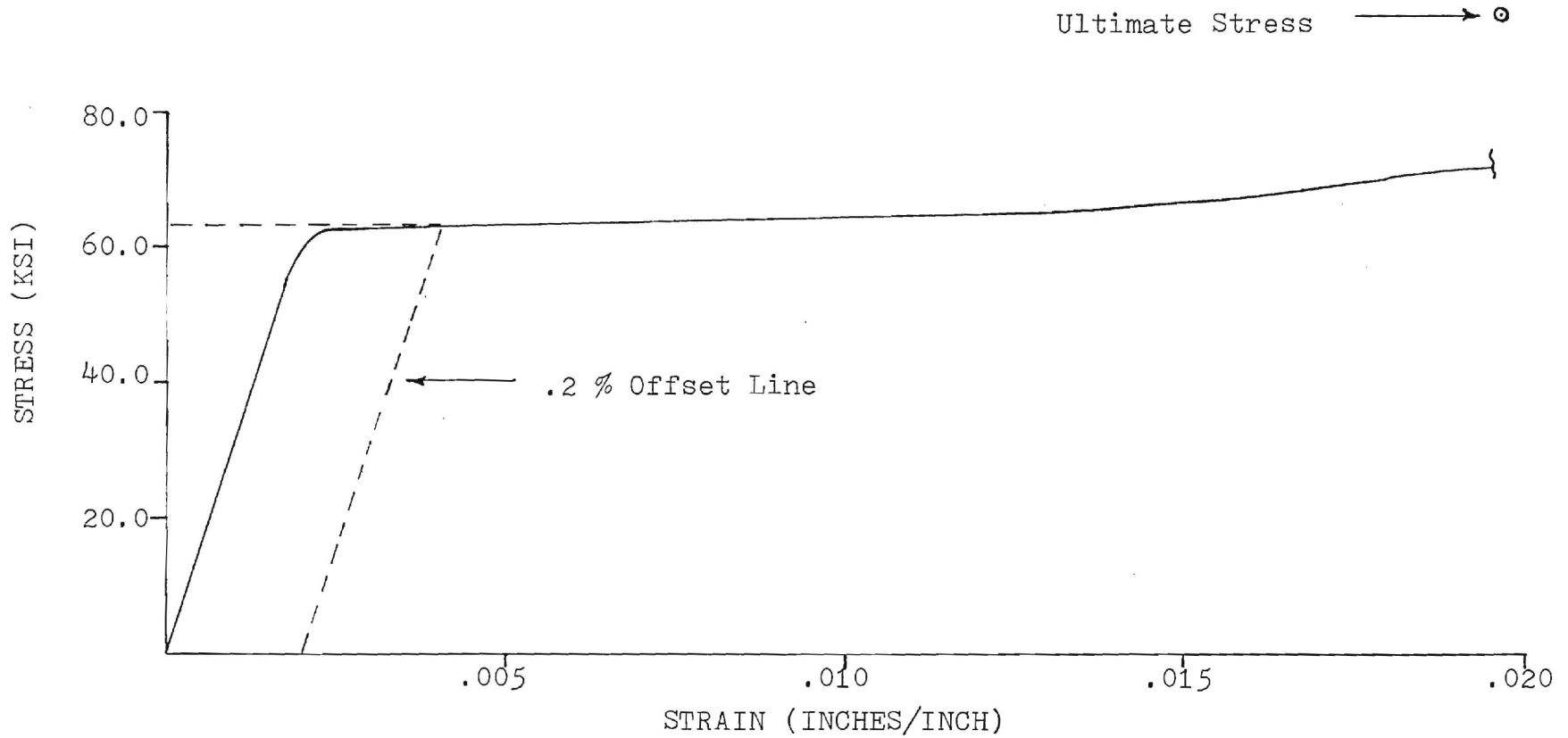

Figure A.5 - Average Stress-Strain Curve for No. 3 Reinforcing Steel Bar

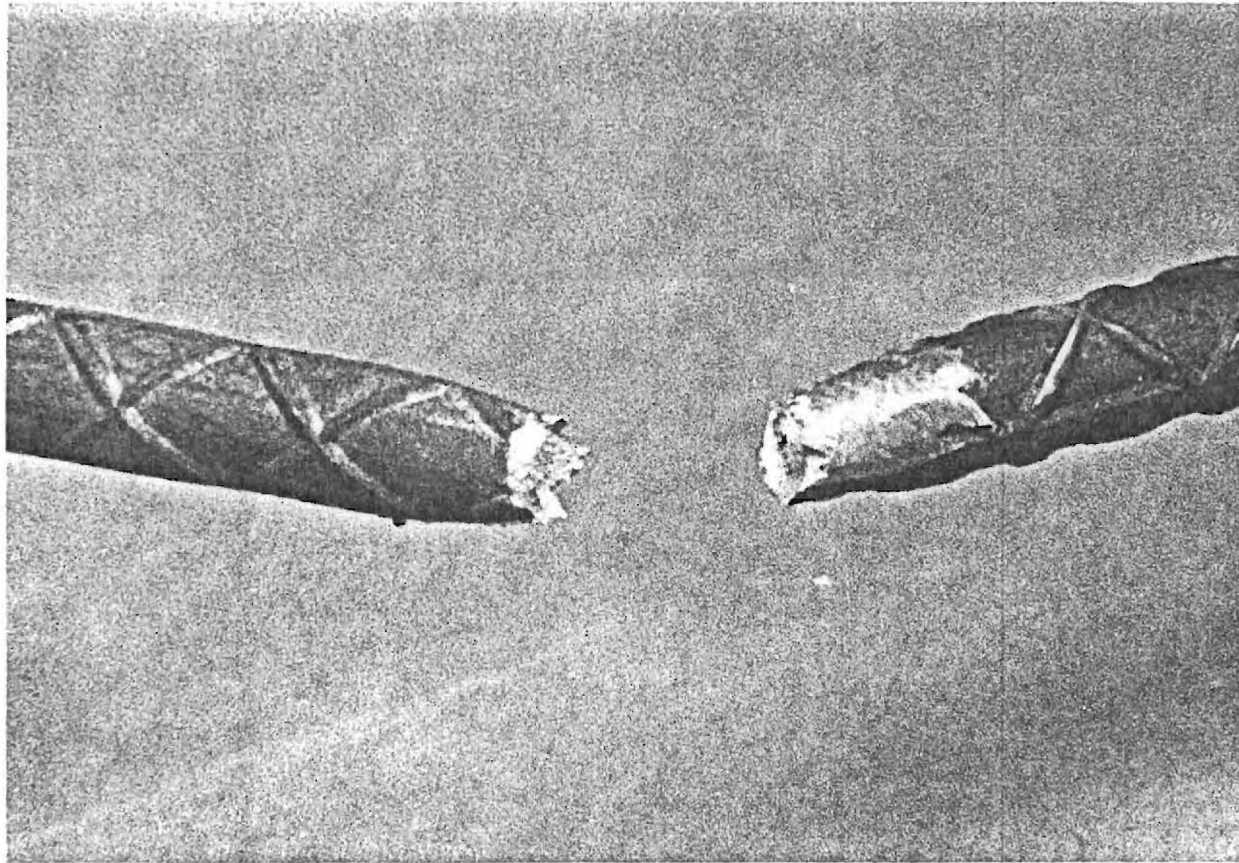

Figure A.6 - Cup-Cone Fracture of No. 3 Reinforcing Bar Specimen

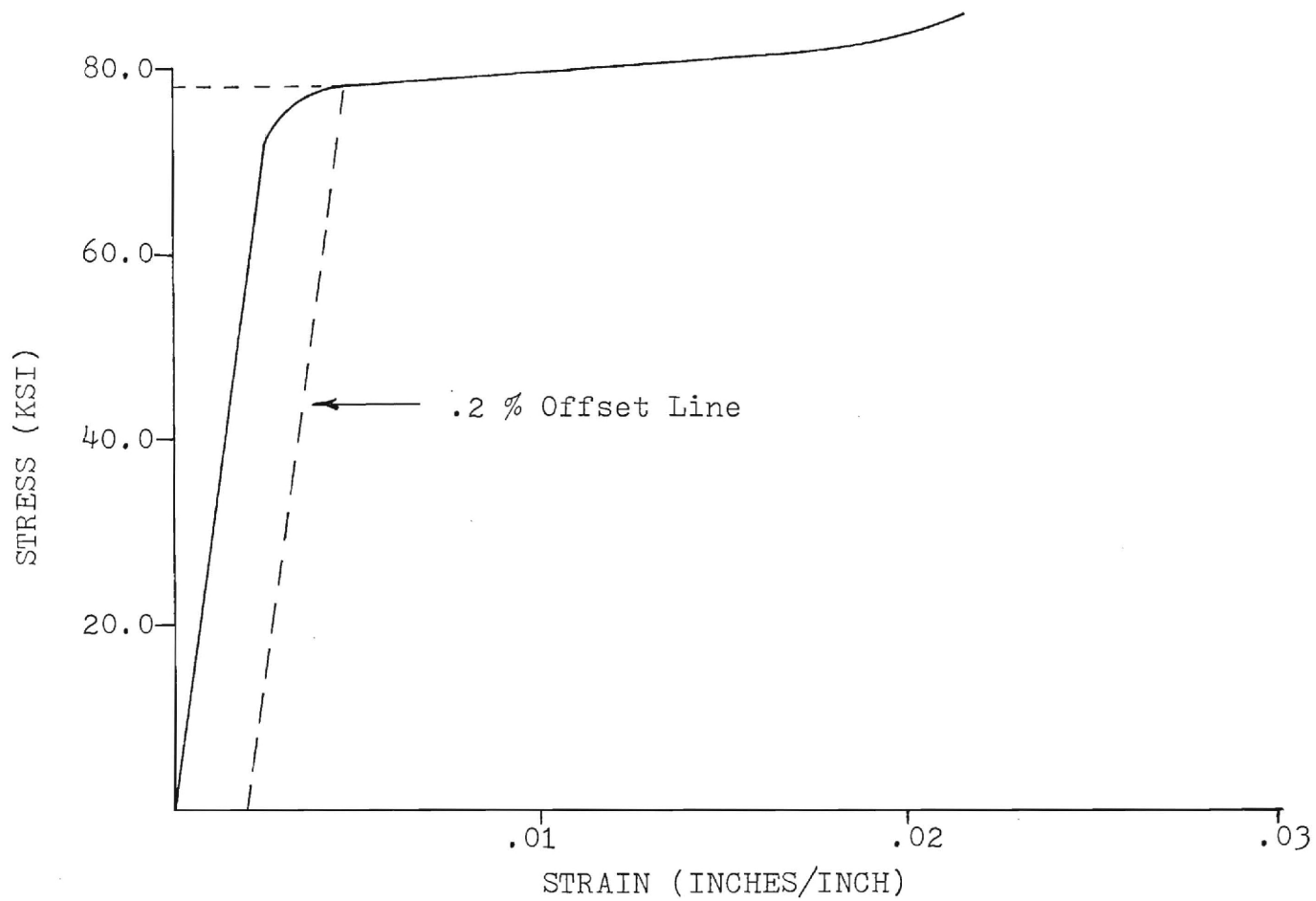

Figure A.7 - Average Stress-Strain Curve for No. 2 Reinforcing Tie

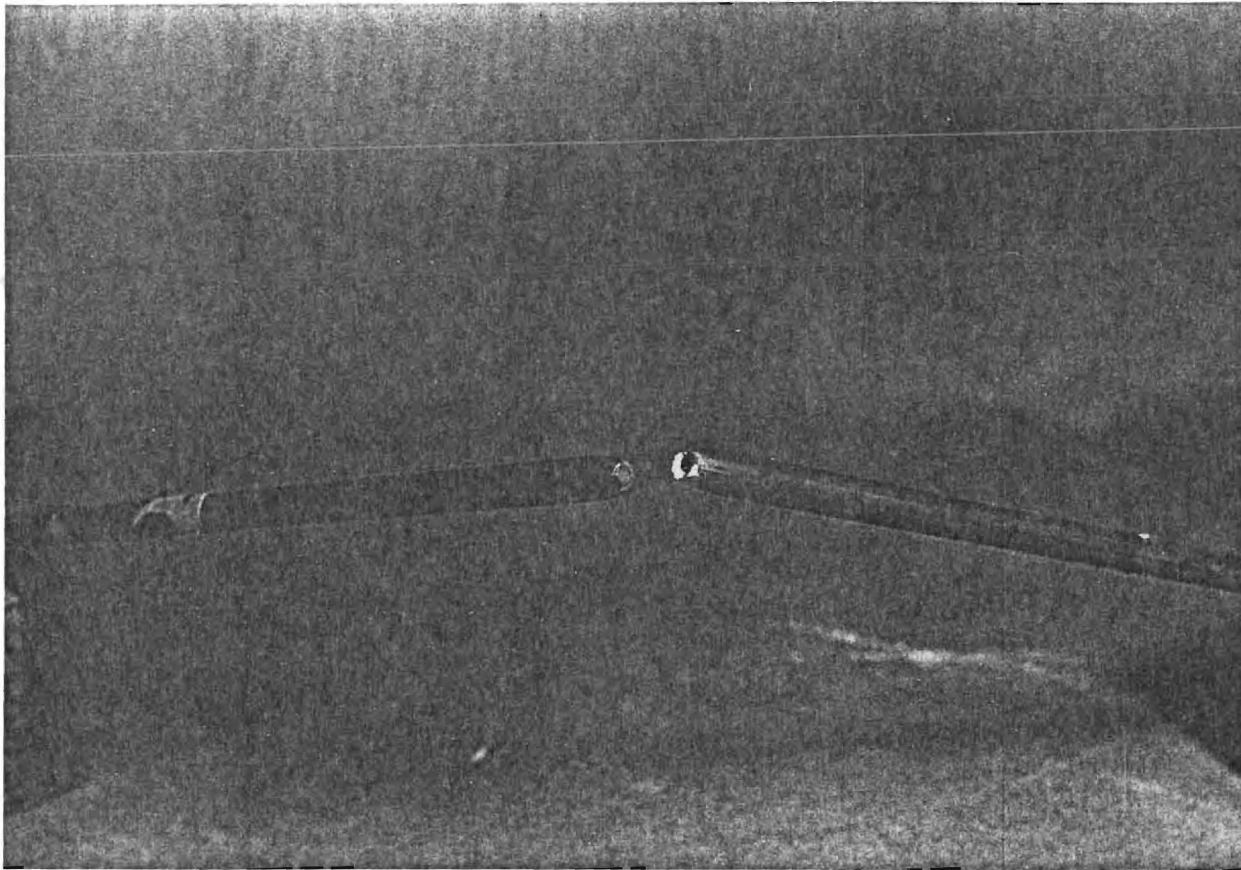

Figure A.8 - Cup-Cone Fracture of No. 2 Reinforcing Tie Specimen

strength tests were conducted on fog room cured concrete cylinders. Field cured cylinders were tested for compressive strength when the actual column prototypes were tested. All cylinders are ASTM specified 6 inches in diameter and 12 inches in height.

Fifteen cylinders were cast when the first two column specimens were poured. On the day after casting, six cylinders were moved to a fog room for 28 day cure at 100 percent relative humidity and 73°F temperature condition. The remaining cylinders were placed next to the columns to simulate field cure conditions. Fifteen test cylinders were cast with the second set of two columns; again six were fog cured while nine were field cured. Since the castings took place at different times, the following 28 day compressive and split tensile test procedures were performed twice so material properties for each pouring could be determined. The properties are listed in Table A.2.

#### A.2.1 28 Day Compressive Tests

After 28 days had elapsed, three fog cured cylinders were capped with liquid sulfur and positioned in a standard cylindrical compressor. This apparatus, was equipped with a ten-inch gage length and deflection dial accurate to 1/1000 inch.

Stress and strain values for the first set of three cylinders were averaged to produce the graph in Figure A.9. The modulus of elasticity was found using the ASTM recommended equation (5):

$$E = (S_2 - S_1) / (E_2 - .00005)$$

where  $S_2$  and  $E_2$  are stress and strain values at 40 percent of the ultimate stress, while  $S_1$  is the stress corresponding to .00005 inches per inch strain.

Figure A.10 is the average stress-strain curve for the three cylinders cast for the second set of columns, Number 2 and 4. The modulus of elasticity was computed as previously described.

All six cylinders fractured to produce the usual cone configuration. The nominal compressive strength of 6000 psi was much higher than the 4000 psi requested of the commercial ready-mix distributor.



TABLE A.2

Material Properties for Concrete  
(Properties are Averages of Three Tests)

Column Specimen Numbers	Compressive Strength (psi)	Tensile Strength (psi)	Modulus of Elasticity (psi)
1,3	6,350	490	3,700,000
2,4	6,470	445	3,200,000

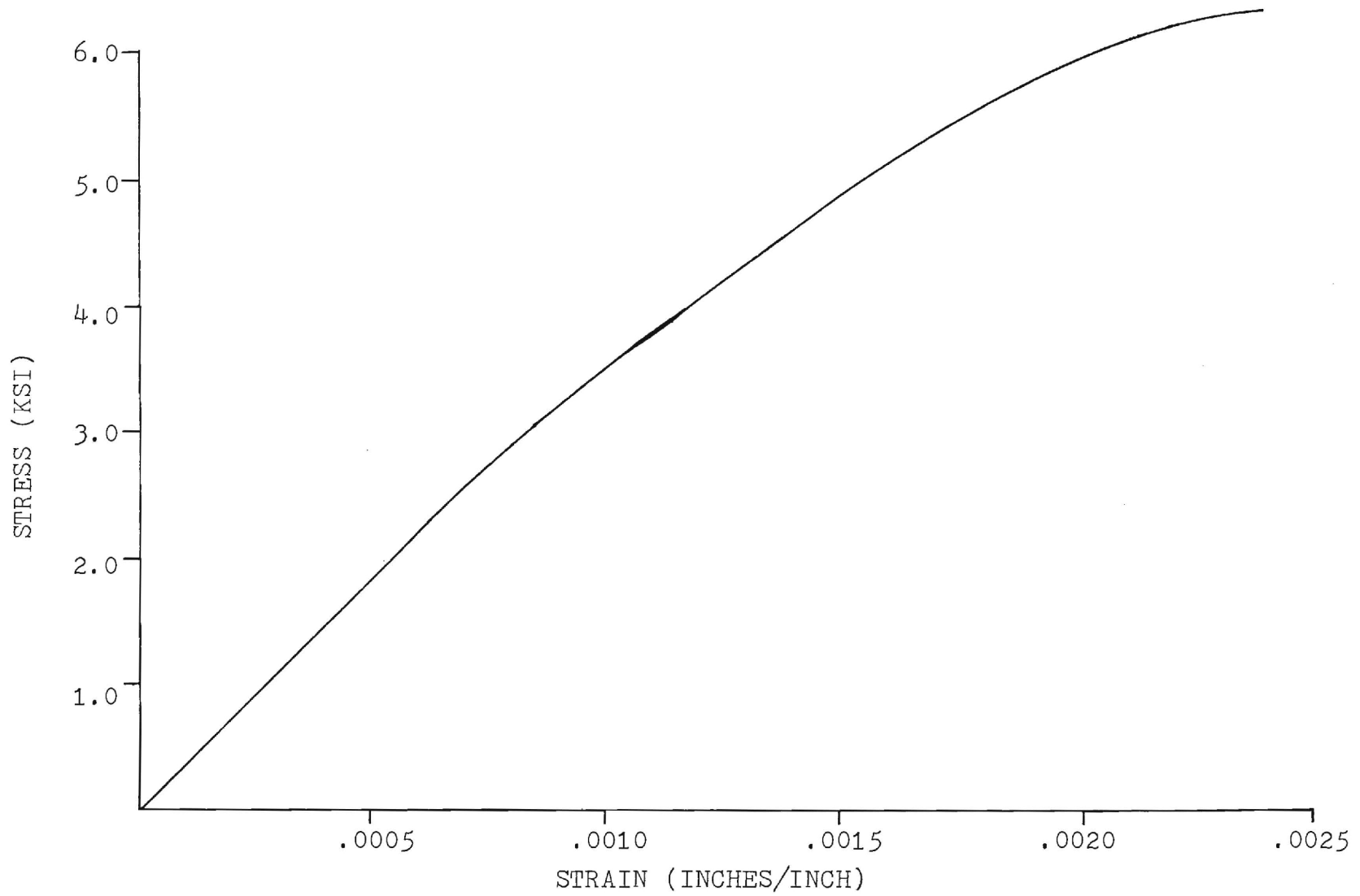

Figure A.9 - Average Stress-Strain Curve for Concrete Cylinders 1, 2 and 3

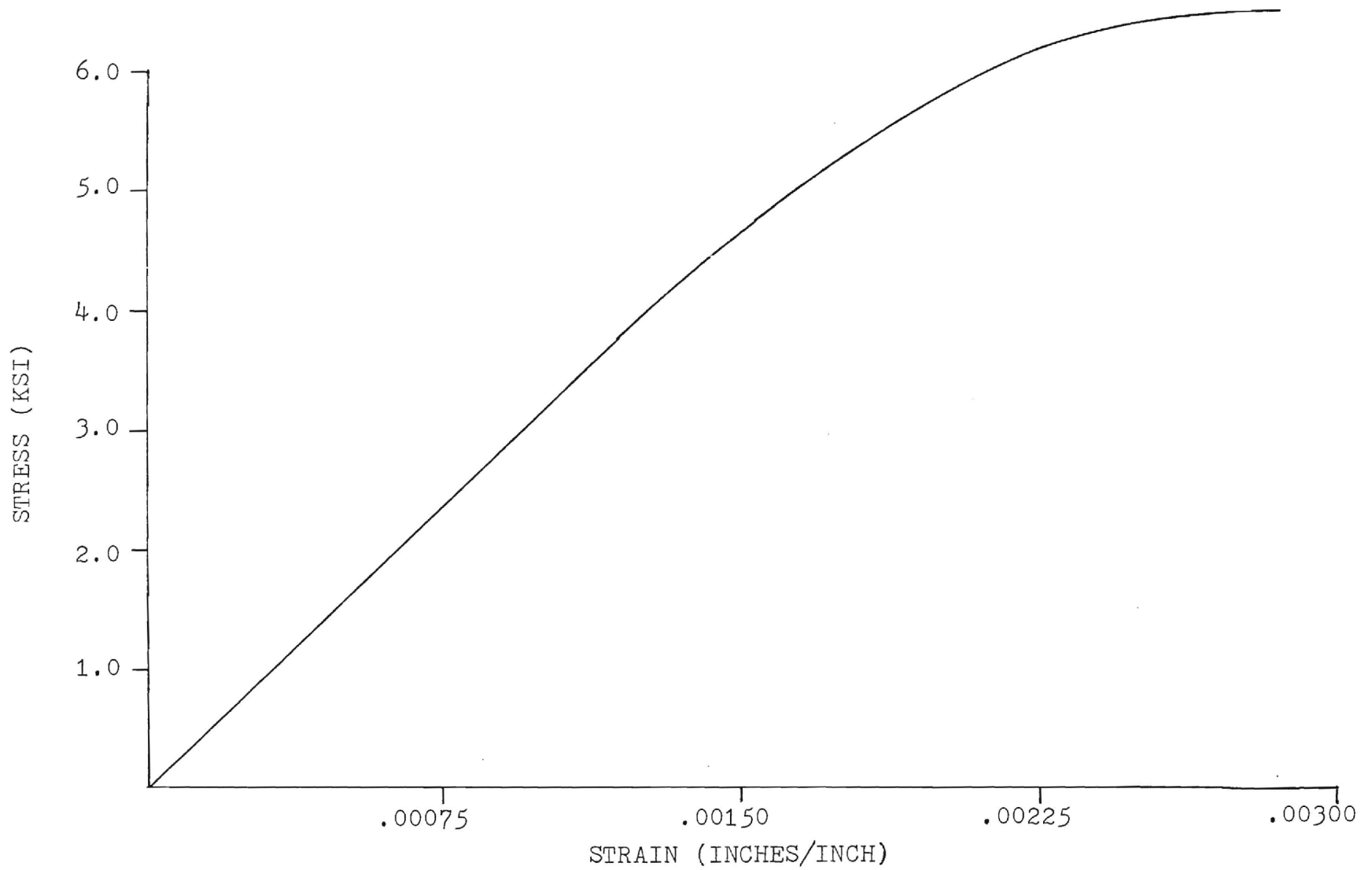

Figure A.10 - Average Stress-Strain Curve for Concrete Cylinders 4, 5 and 6

### A.2.2 Split Tension Tests

Three fog cured cylinders of each set were used to determine the split tensile strength. The ASTM specified method for testing split tensile specimens was followed. The average splitting load, computed from the three tensile test results, was used to calculate the tensile strength following the ASTM equations:

$$\sigma_t = (2P)/(\pi dL)$$

where  $\sigma_t$  equals the average tensile strength (psi), P equals the average splitting load (lbs), d equals the cylinder diameter (in) and L equals the cylinder length (in). This is an approximation because of local stress conditions at the load lines and the presence of stresses at right angles to the tension stresses.

### A.3 Specimen Wrappings

The reinforced concrete column specimens were strengthened by wrapping various reinforcement materials around the columns. Samples of these materials were tested in tension to determine their properties. These strengthening materials included a cold drawn No. 2 reinforcing bar, 5/16 x 2 inch flat plates, 5/16 x 7/8 inch coupons cut from steel angles 3 x 5 x 5/16 and 1/20 x 2 inch packaging steel bands. The fourth wrapping technique using standard U ties will not be employed in the immediate project research. Table A.3 lists material properties calculated from the specimen tests. The ASTM recommended 0.2 percent offset method was used for locating the yield stresses.

#### A.3.1 No. 2 Reinforcing Bar

One cold drawn No. 2 reinforcing bar was tensioned by an Instron Testing Machine. A one-inch gage length extensometer which was electrically attached to an autographic plotter was used to register and graph the load-elongation curve. This curve was transformed into a stress-strain curve shown in Figure A.11. The reinforcing bar, which met ASTM specifications for A 615 Grade 40, exhibited ductility prior to fracture.

TABLE A.3

## Material Properties for Specimen Wrappings

Wrapping Material	Yield Stress (ksi)	Ultimate Stress (ksi)	Ultimate Strain (in/in)	Modulus of Elasticity (ksi)
No. 2 Cold Drawn Reinforcing Bar*	66.88	72.34	.058	29,000
2" x 5/16" Flat Coupon**	42.60	69.00	.225	29,600
Angle Coupon**	34.10	55.00	.432	28,900
Packaging Band**	93.70	117.44		27,600

\* Average 1 Test

\*\* Average 2 Tests

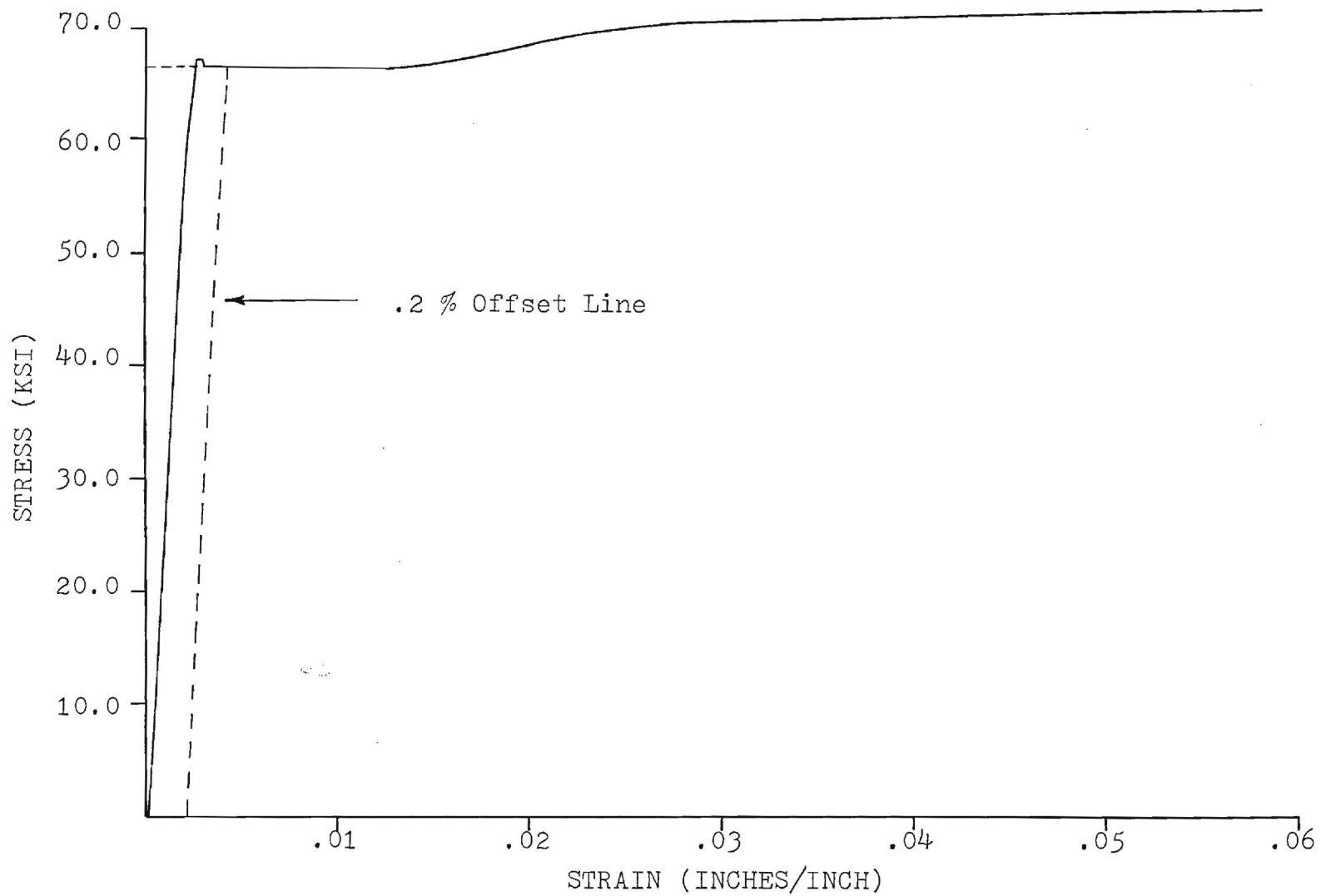

Figure A.11 - Average Stress-Strain Curve for Cold Drawn No. 2 Bar

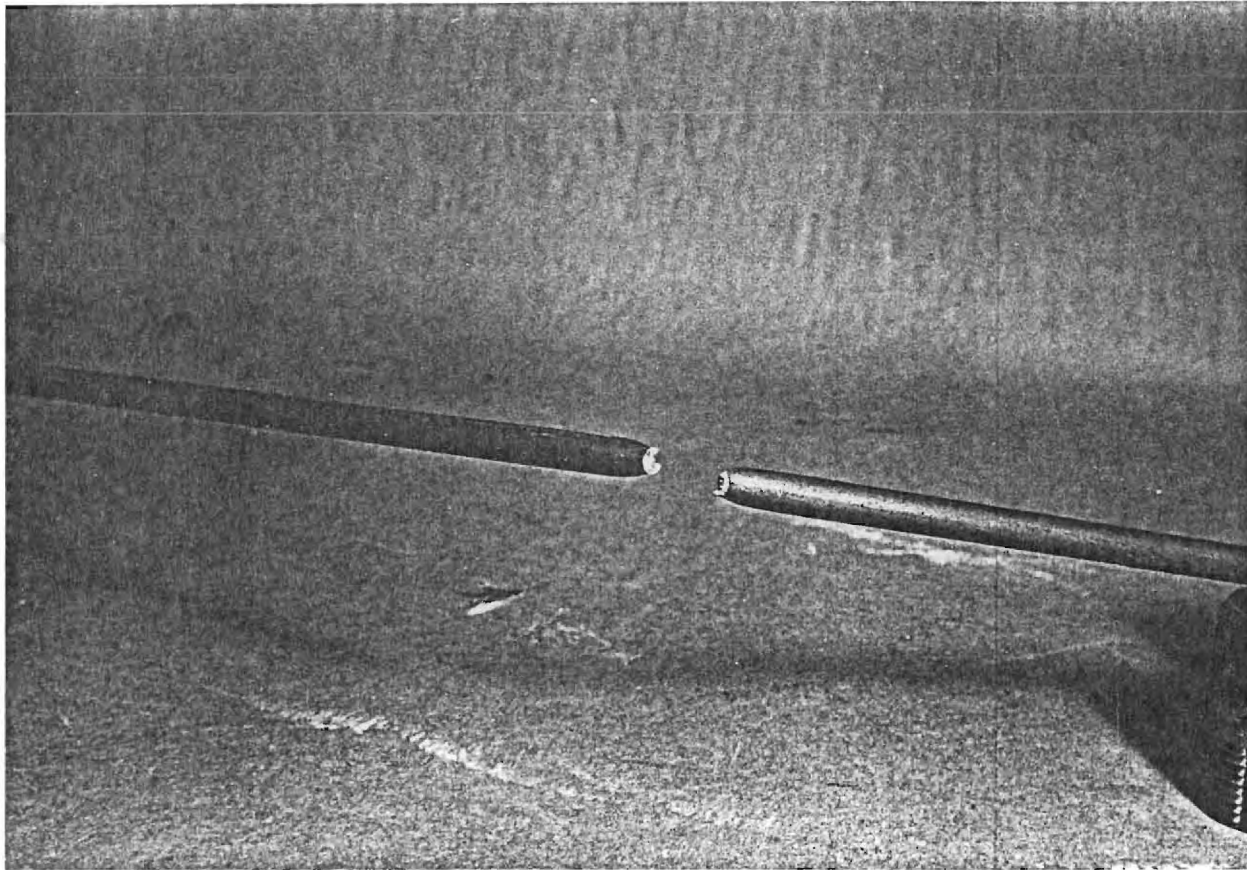

Figure A.12 - Cup-Cone Fracture of Cold Drawn No. 2 Reinforcing Bar



### 3.3.2 U-Clamps

The second wrapping technique was composed of two separate steel components welded together as shown in Figure A.13. These components were 10 x 2 x 5/16 inch steel strips and 2 1/4 inch wide strips of 3 x 5 x 5/16 steel angle. The angle contained bolt holes in the 3 inch leg for keeping two U-Clamp assemblies together. Coupons were saw cut from lengths of the 2 x 5/16 bar and from the angle for determining properties of these steels. Testing was performed in a Tinius-Olsen Universal Testing Machine with an LVDT extensometer of two-inch gage length electrically attached to an autographic plotter. Load-strain curves were automatically plotted until yield strains occurred (approximately .002 inches per inch for flat strips and .015 inches per inch for angle strips). After yielding, readings were taken with calipers positioned between two marks, initially inscribed two inches apart. This technique is an ASTM accepted method for testing sheet type specimens.

Two of these coupon specimens were machined to a width and length of 3/4 inch and 4 inches respectively, in the center area of the bar. The machined specimens met ASTM specifications for a sheet type specimen with a single exception; the gage width was cut slightly larger than recommended. The load-strain curves, along with data from caliper measurements, were reduced and the resulting average stress-strain curve is shown in Figure A.14. The ductile fracture of one of the specimens, which occurred outside the gage length, is illustrated in Figure A.15.

In order to obtain coupon specimens of adequate testing length from the steel angle, one leg of an angle was cut into two 10 inch strips as shown in Figure A.16. The center portions of these two strips were machined to a width and length of 11/16 inch and 3 7/16 inches respectively. The specimens satisfied ASTM requirements with a single exception; the overall specimen width was slightly smaller than recommended. The average stress-strain curve was plotted with data from the tests of both specimens and is shown in Figure A.17.

### 3.3.3 Steel Banding

Two packaging band specimens, which represented the third wrapping

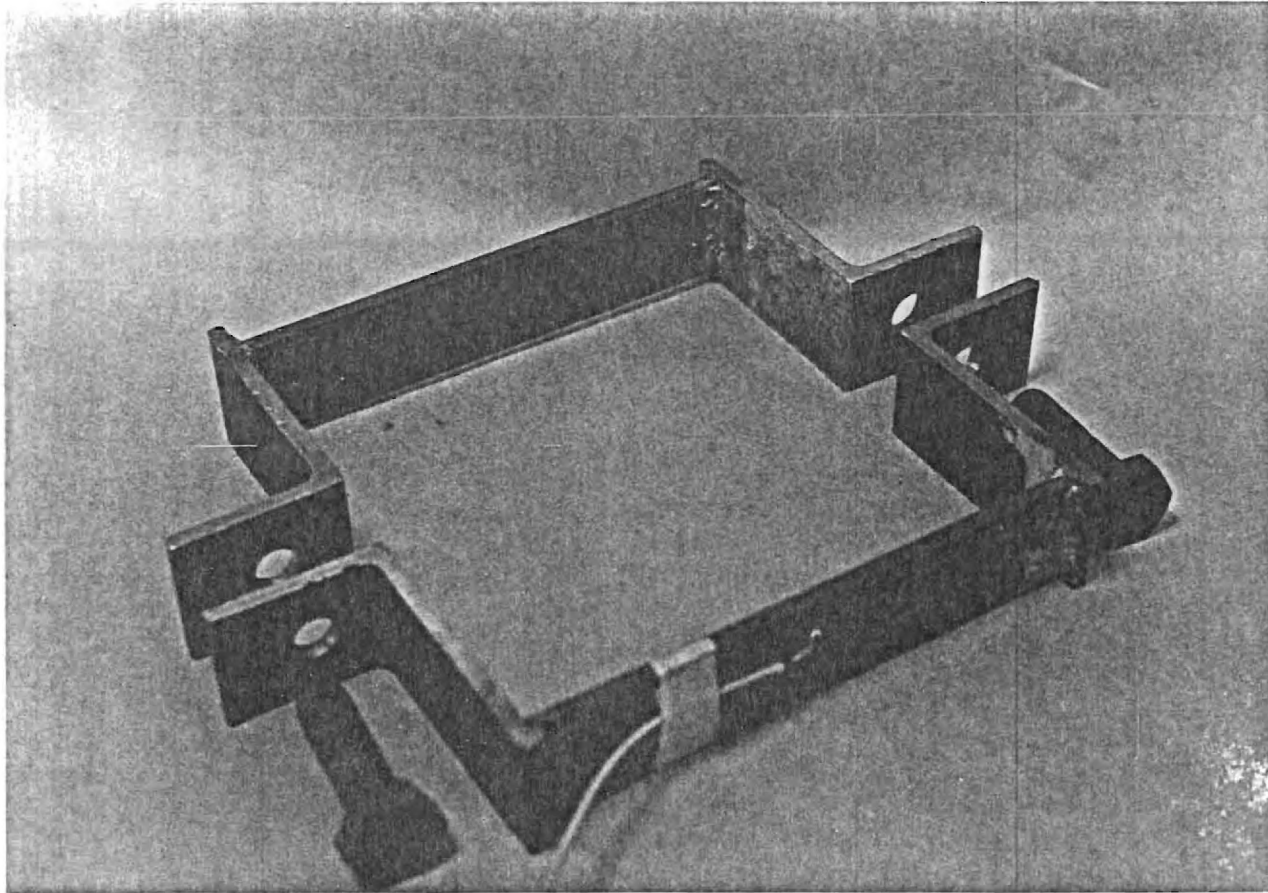

Figure A.13 - Welded Components of the Second Strengthening Technique

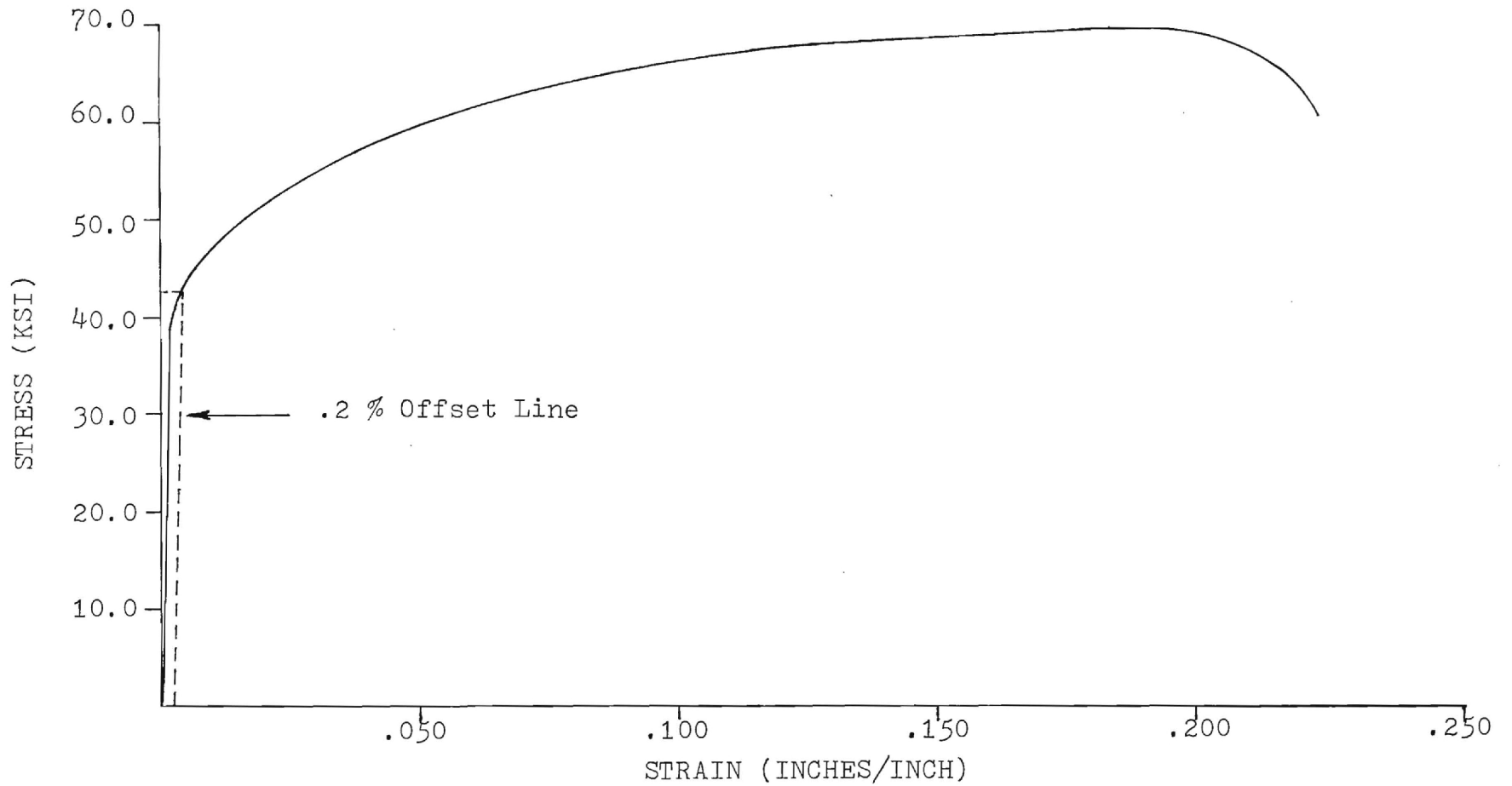

Figure A.14 - Average Stress-Strain Curve for 10 x 2 x 5/16 inch Flat Plate

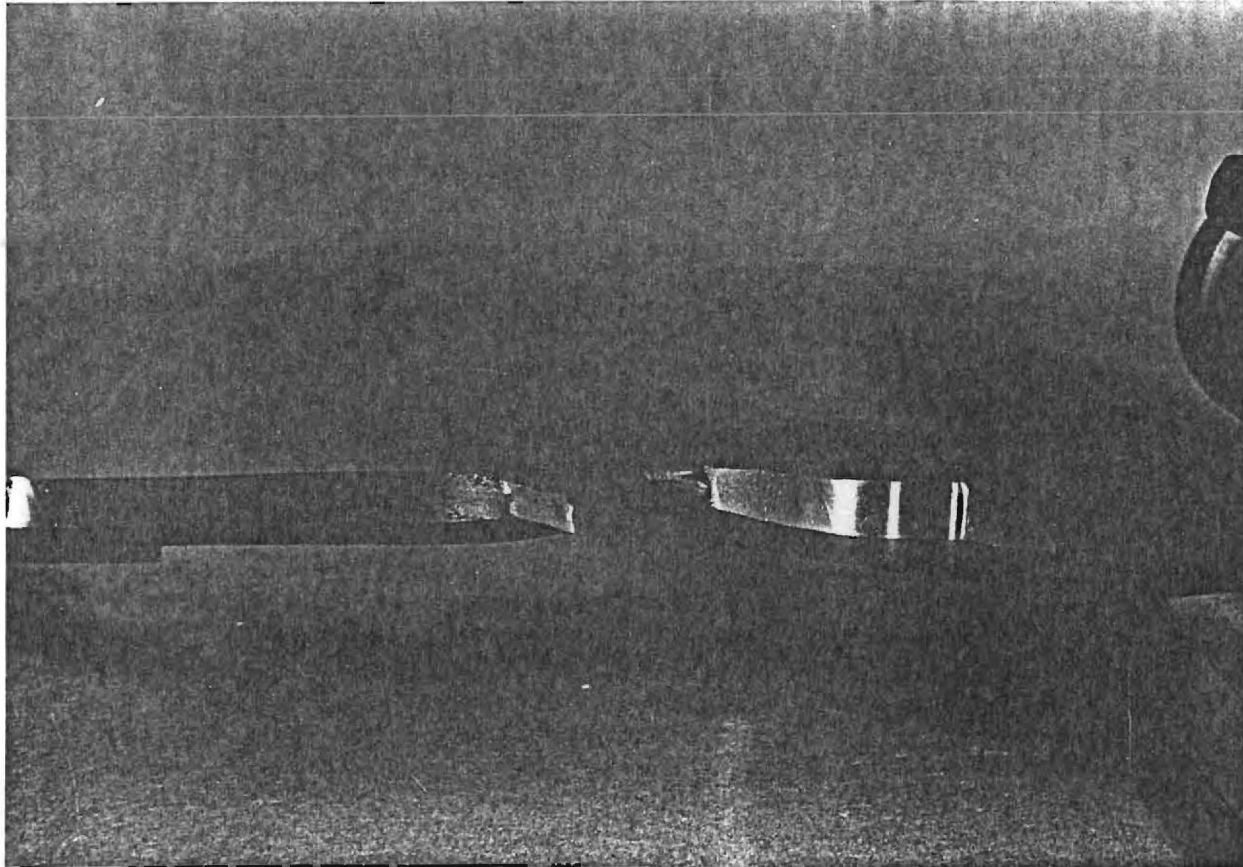

Figure A.15 - Ductile Fracture of a Flat Plate Specimen

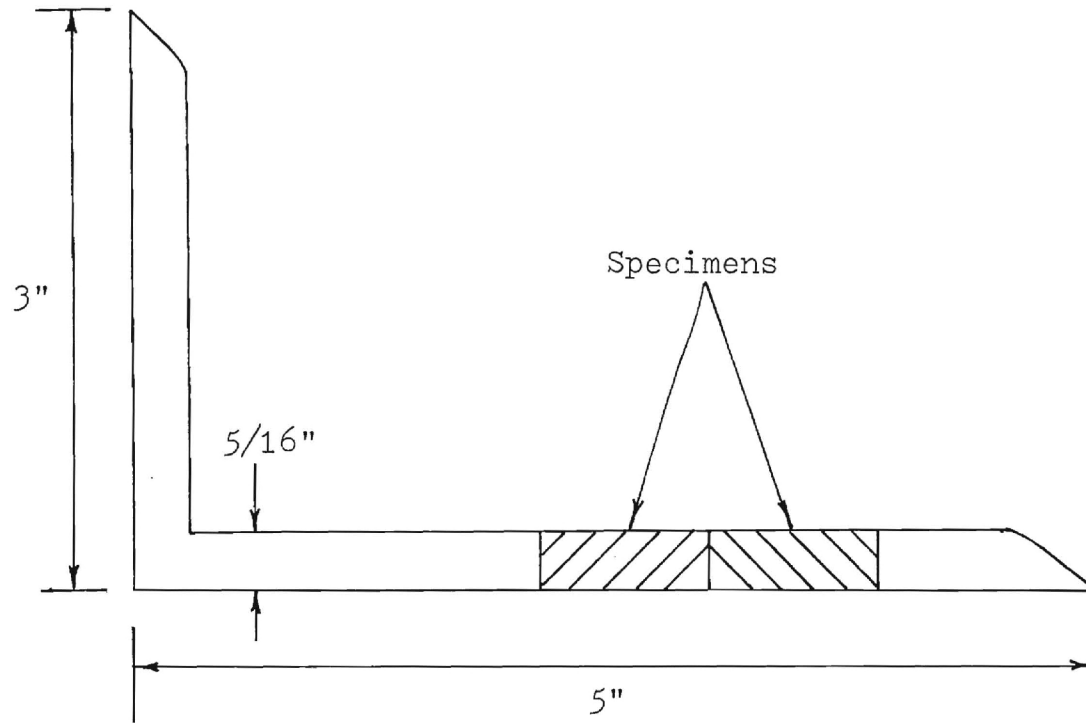

Figure A.16 - Locations of the Two Angle Test Specimens

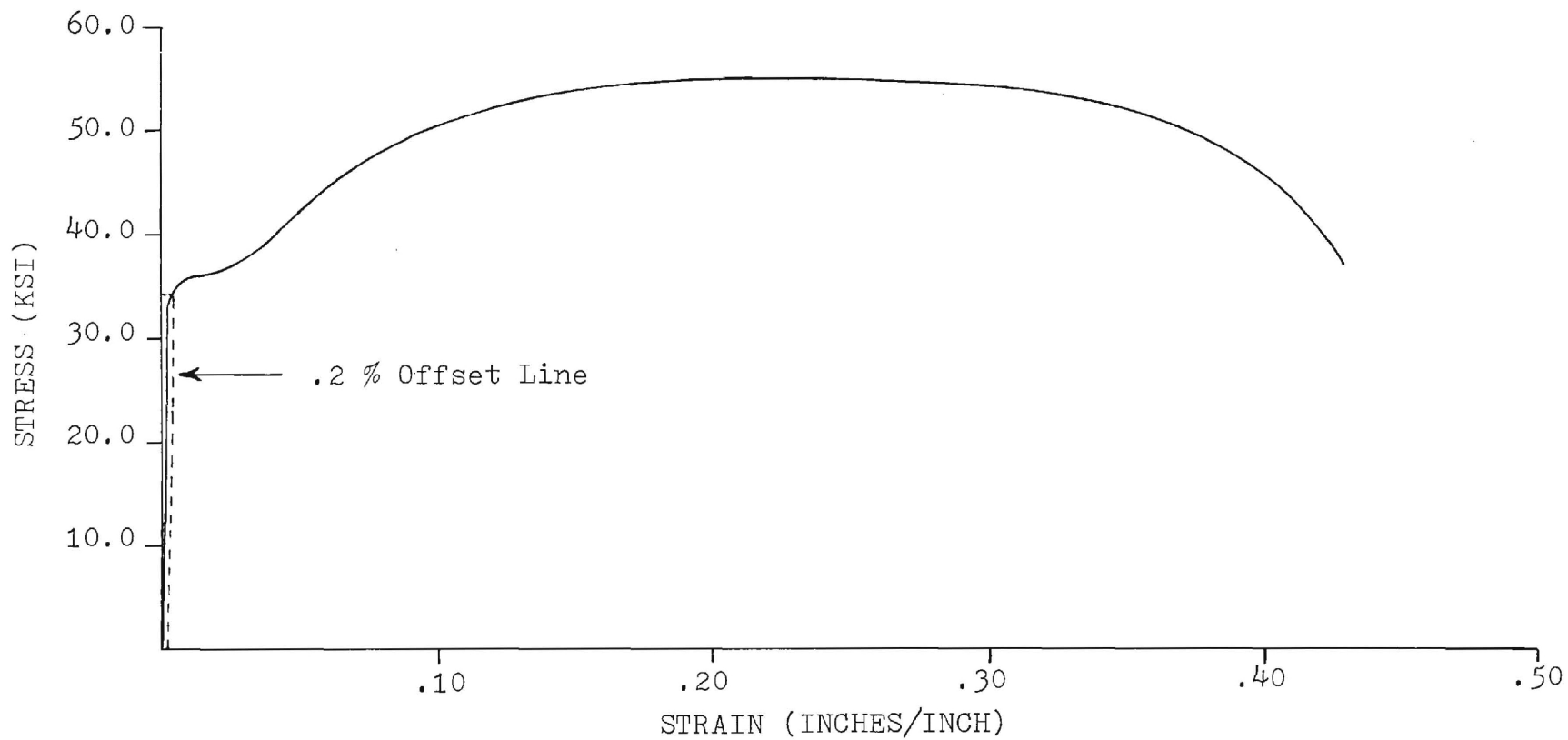

Figure A.17 - Average Stress-Strain Curve for 3 x 5 x 5/16 inch Angle

technique, were tested in a Tinius-Olsen Universal Testing Machine and strain was automatically plotted using the identical LVDT arrangement previously mentioned. Gage marks were not used. The specimens exhibited classical necking configurations shown in Figure A.18. Yield lines developed diagonally across the necked area. The rupture is shown in Figure A.19. The average stress-strain curve, plotted from the load-strain graphs, is shown in Figure A.20.

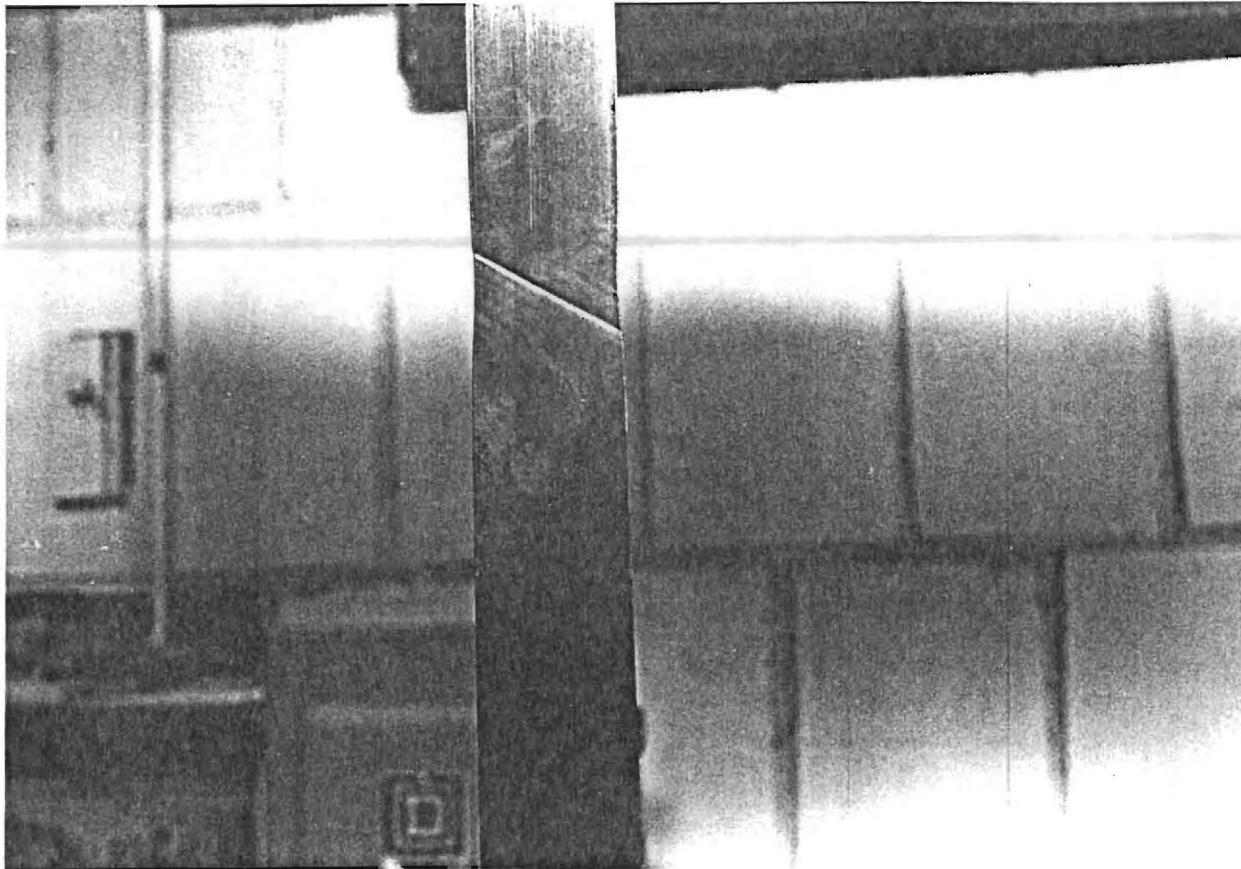

Figure A.18 - Necking of a Packaging Band Specimen



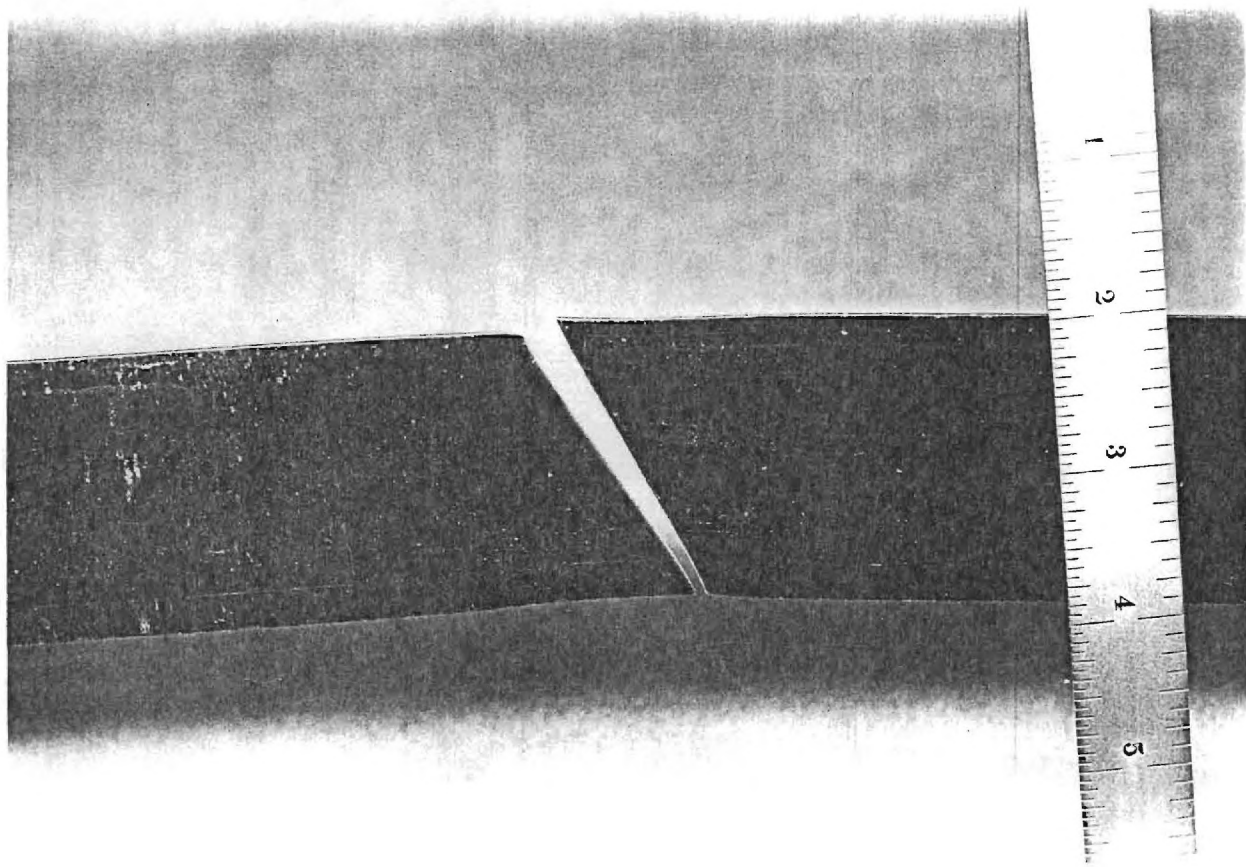

Figure A.19 - Rupture of a Packaging Band Specimen

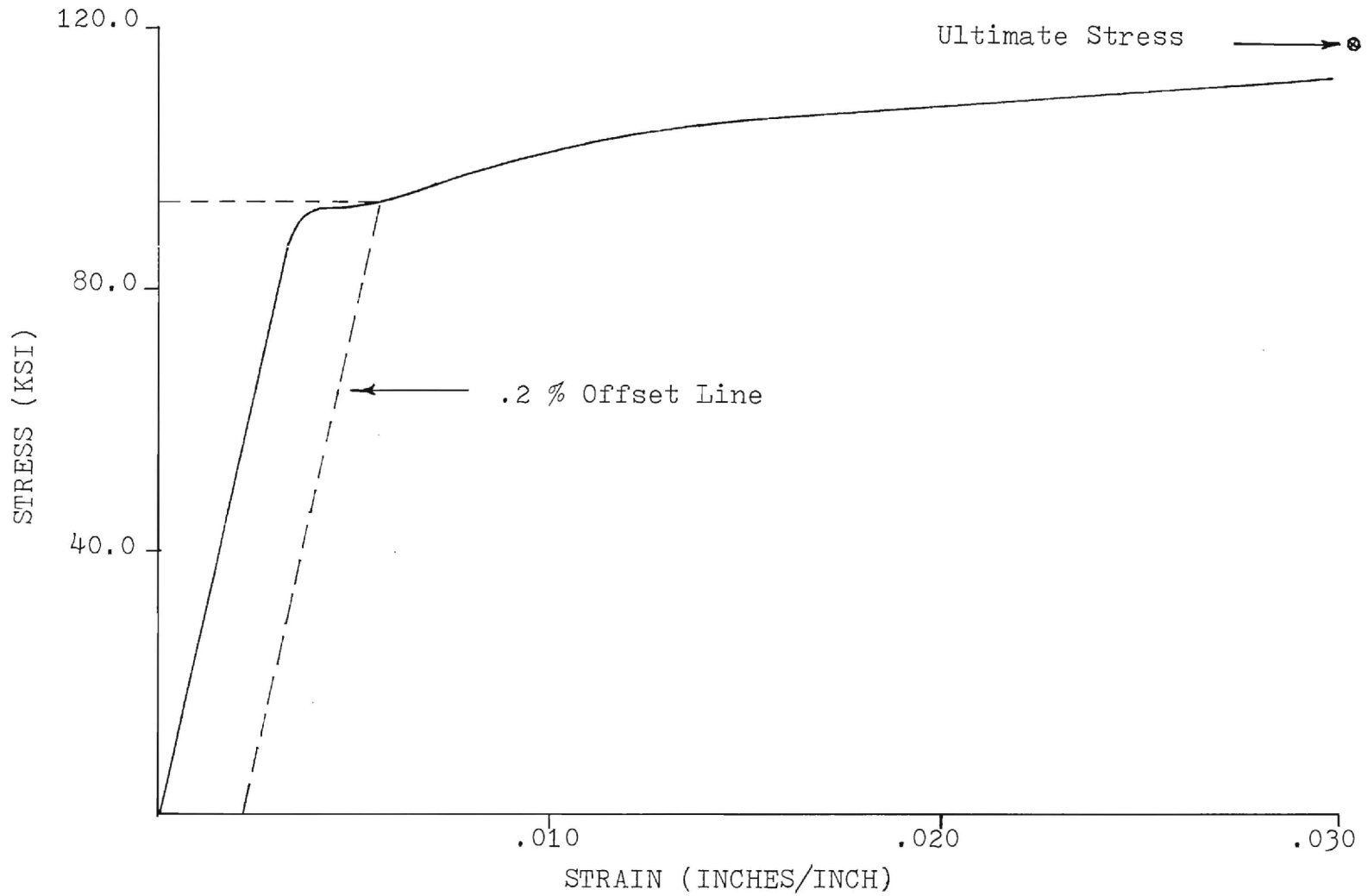

Figure A.20 - Average Stress-Strain Curve for Packaging Band

## REFERENCES

1. Blume, J.A., Newmark, N.M., and Corning, L.H., Design of Multistory Reinforced Concrete Buildings for Earthquake Motion, Portland Cement Association, Chicago, Illinois, 1961.
2. "Building Code Requirements for Reinforced Concrete (ACI 318-63)", ACI Committee 318, American Concrete Institute, Detroit, Michigan, 1963.
3. "Building Code Requirements for Reinforced Concrete (ACI 318-77)", ACI Committee 318, American Concrete Institute, Detroit, Michigan, 1977.
4. Bertero, V.V., and Popov, E.P., "Hysteretic Behavior of Ductile Moment-Resisting Reinforced Concrete Frame Components", Earthquake Engineering Research Center Report EERC 75-16, University of California, Berkeley, April, 1975.
5. Celebi, M., and Penzien, J., "Hysteretic Behavior of Epoxy-Repaired Reinforced Concrete Beams", Earthquake Engineering Research Center Report No. EERC 73-5, University of California, Berkeley, February, 1973.
6. Freeman, S.A., "Modification of Structure to Satisfy New Seismic Criteria", Preprints, Sixth World Conference on Earthquake Engineering, New Delhi, India, 1977, pp 7-91, 7-96.
7. Gulkan, P., "The Inelastic Response of Repaired Reinforced Concrete Beam-Column Connections", Preprints, Sixth World Conference on Earthquake Engineering, New Delhi, India, 1977, pp. 7-55, 7-60.
8. Hanson, R.D., and Degenkolb, H.J., The Venezuela Earthquake, July 29, 1967, American Iron and Steel Institute, New York, 1969.
9. Hidalgo, P., and Clough, R.W., "Earthquake Simulator Study of a Reinforced Concrete Frame", Earthquake Engineering Research Center Report No. EERC 74,13, University of California, Berkeley, December, 1974.
10. Higashi, Y., and Kokusho, S., "The Strengthening Methods of Existing Reinforced Concrete Buildings", Proceedings of the U.S. - Japan Cooperative Research Program in Earthquake Engineering with Emphasis on the Safety of School Buildings, Honolulu, Hawaii, August, 1975.
11. Ikeda, A., "Load-Deformation Characteristics of Reinforced Concrete Columns Subjected to Alternating Loading", Report of the Training Institute for Engineering Teachers, Yokohama National University, March, 1968.
12. Kajfasz, S., "Concrete Beams with External Reinforcement Bonded by Glueing, Preliminary Investigation", Proceedings of the RILEM International Symposium, Paris, France, September, 1967.

13. Lee, D.L.N., "Original and Repaired Reinforced Concrete Beam-Column Subassemblages Subjected to Earthquake Type Loading", Ph.D. Thesis, University of Michigan, Ann Arbor, April, 1976.
14. Mahin, S., Bertero, V.V., Atalay, M.B., and Rea, D., "Rate of Loading Effects on Uncracked and Repaired Reinforced Concrete Members", Earthquake Engineering Research Center Report No. EERC 72-9, University of California, Berkeley, December, 1972.
15. Murphy, L.M., Coordinator, San Fernando, California, Earthquake of February 9, 1971, Volume 1, National Oceanic and Atmospheric Administration, U.S. Department of Commerce, Washington, D.C., 1973.
16. "Shear Strength of Reinforced Concrete Members", ASCE-ACI Task Committee 426, Journal of the Structural Division, ASCE, Vol. 99, No. ST 6, June 1973, pp 1091-1187.
17. Spracklen, R.W., "Repair of Earthquake Damage at Holy Cross Hospital", ASCE National Structural Engineering Conference, Preprint 1941, San Francisco, California, April, 1973.
18. Uniform Building Code, International Conference of Building Officials, Whittier, California, 1973.
19. Vallenias, J., Bertero V.V., and Popov, E., "Concrete Confined by Rectangular Hoops and Subjected to Axial Loads", UCB/EERC-77/13, Earthquake Engineering Research Center, University of California Berkeley, August, 1977 (NTIS Accession No. PB275165).
20. Wight, J.K., and Sozen, M.A., "Strength Decay of RC Columns Under Shear Reversals", Journal of the Structural Division, ASCE, Vol. 101, No. ST5, May, 1975, pp. 1053-1065.