

УДК 531.39

Strackeljan J.<sup>1</sup>, Babenko A.<sup>2</sup>, Lavrenko Ia.<sup>2</sup>1 - Otto-von-Guericke University Magdeburg, Germany, ([jens.strackeljan@ovgu.de](mailto:jens.strackeljan@ovgu.de)) ;2 - The National Technical University of Ukraine «Kyiv Polytechnic Institute», Kyiv, Ukraine  
([babenko.ac@gmail.com](mailto:babenko.ac@gmail.com), [lavrenko.iaroslav@gmail.com](mailto:lavrenko.iaroslav@gmail.com))

## NECESSARY CONDITIONS OF STABILITY MOVING PARTS OF ROTOR CENTRIFUGE

Штракельян<sup>1</sup> Й., д.т.н., проф., Бабенко А.Є.<sup>2</sup>, д.т.н., проф., Лавренко Я.І.<sup>2</sup>

1 - Отто-фон-Герике Університет Магдебурга, Німеччина ;

2 - НТУУ України «Київський політехнічний інститут», м. Київ, Україна

### НЕОБХІДНІ УМОВИ СТІЙКОСТІ РУХОМИХ ЕЛЕМЕНТІВ РОТОРА ЦЕНТРИФУГИ

*Design features of modern centrifuges studied. Revealed that their rotors are movable elements that revolve around horizontal axes. The dynamics of these moving parts of laboratory centrifuge considered. Using the Lagrange equation of the second kind the resulting differential equations of their motion considered. The modeling visualization of motion using the software package RecurDyn was made. The results that obtained by the research package RecurDyn and analytically showed that their motion can be unstable in the positions that are optimal in terms of the technological process. The differential equation can be not integrated in elementary functions, so direct analysis of movement is difficult. As a result of this stability conditions for motion with linear approximation investigated. Necessary conditions for stability of motion required of the design obtained.*

*Keywords:* Motion, stability, rotation, speed, vibration.

**Introduction.** Centrifuges are used in different industries, medical laboratories, agriculture, to separate mixtures into fractions consisting of substances of different densities. The main objectives of the design are the quality of fractions and reliability.

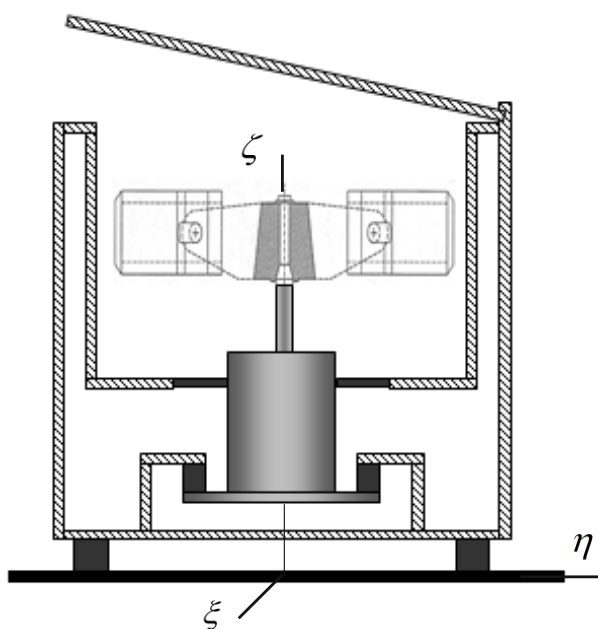

Fig. 1. Laboratory centrifuge

High precision centrifuge (Fig.1) must provide a high degree of separation of the mixture. To ensure a high degree of separation require high centrifugal force and motion stability. These requirements can be provided only in terms of the dynamic characteristics, knowledge of which makes it possible to determination of stable and unstable conditions of motion centrifuge.

**Actuality.** From the parameters of centrifuge depends quality of required work [1, 2, 3]. Transient processes and vibration can impair the original products. Based on this study mechanical characteristics of centrifuges and influence on them using structural factors are the actual problems in the design.

Consider the different operating conditions, industry supports a wide range of laboratory centrifuge rotors. Often modern centrifuges used moving parts that affect the movement of the centrifuge. These elements are movable rotor cups that attach to the pin (Fig.2).

A cup (II) of rotor (I) with different forms for containers (III) is fixed on the pin and changes its position during acceleration and stop. The rotor (I) was investigated in the form of crosses with cups in which form we measure glass with mixtures of substances of different densities. From parameters of motion centrifuge and pins depends

the quality of required work. Separation is most effective at maximum centrifugal force.

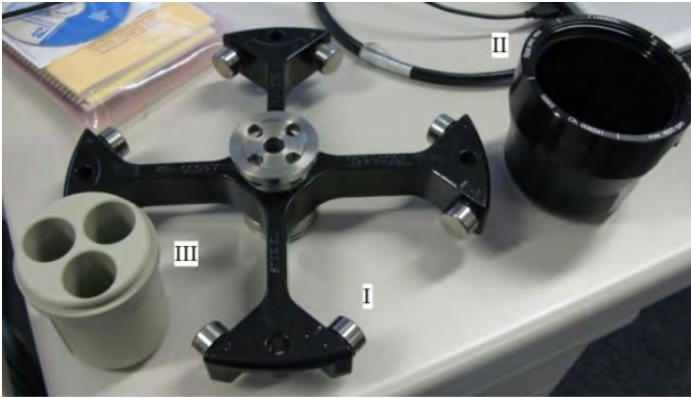

Fig. 2. Rotor and cup of laboratory centrifuges

From parameters of motion centrifuge with elements depends on the quality of necessary work. Availability of such elements essentially influences occurrence of transient processes and vibrations, which affect product quality and efficiency of the process and cause damage [4, 5]. Therefore, the definition of the necessary conditions of stability of motion cups are the actual problems of design.

Using the software package RecurDyn is conducted the modeling of the dynamic behavior of the centrifuge. A number of possible positions of cup depending on the speed of rotation shown in Fig.3.

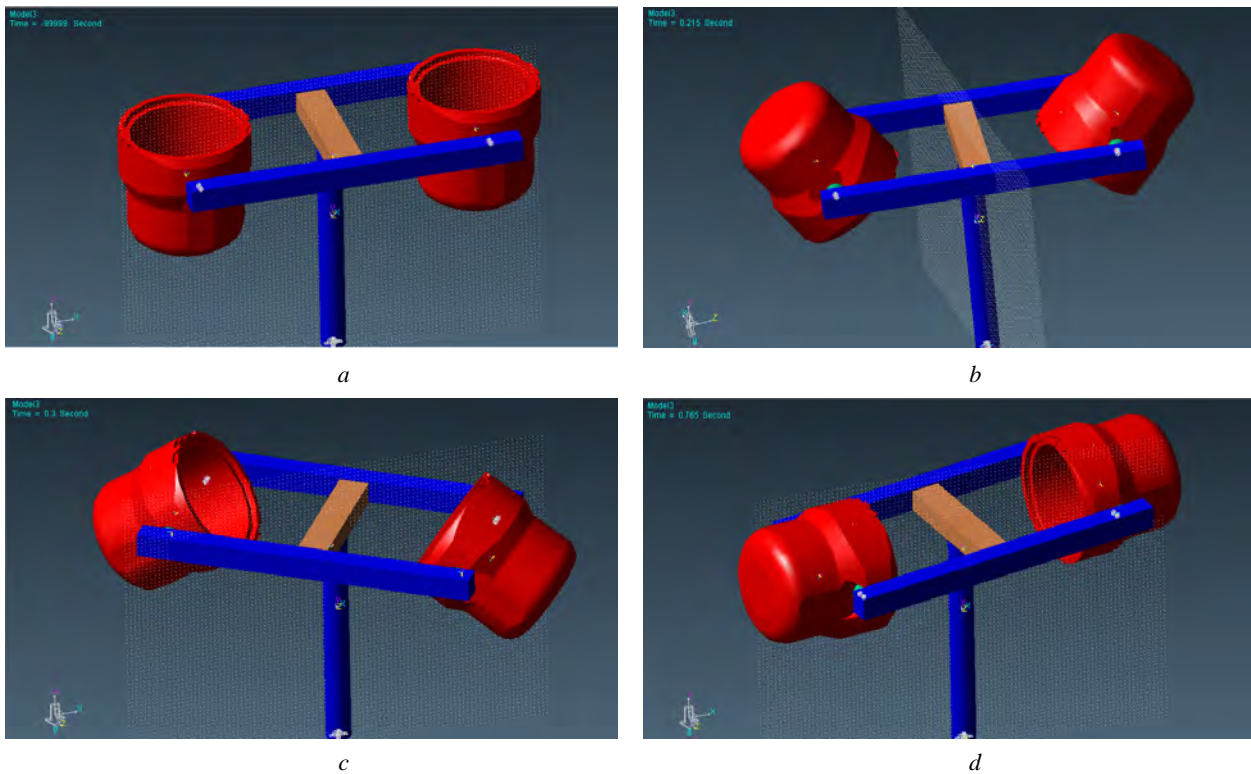

Fig. 3. Cups position while moving  
a)  $t = 0$  sec; b)  $t = 0,215$  sec; c)  $t = 0,3$  sec; d)  $t = 0,765$  sec;

The results show that the movement of cups can be unstable. To determine the parameters which necessary conditions of movement and stable motion centrifuge created the design model, shown in Fig.4.

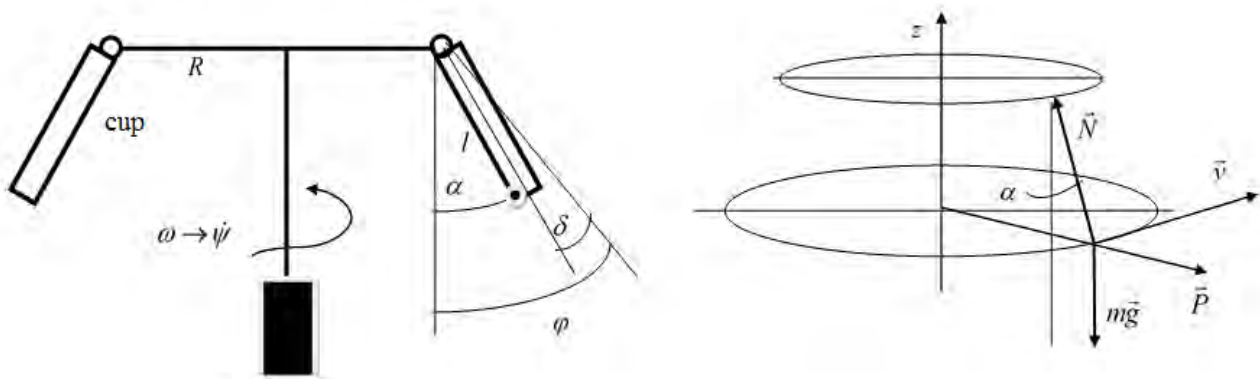

Fig. 4. Schematic representation the cups of the centrifuge rotor

Figure (Figure 4) shows  $\vec{v}$  – circular speed,  $\vec{P}$  – centrifugal force,  $\vec{N}$  – axial force of shaft. It is believed that the angle  $\alpha$  corresponds to stable regime and angular speed of revolution the centrifuge in the steady state is  $\omega$ .

The condition of balance by D'Alembert principle, we obtain

$$\vec{N} + \vec{P} + m\vec{g} = 0,$$

$$N \cos \alpha = mg, \quad N \sin \alpha = P.$$

Separation is most effective at maximum centrifugal force

$$P = m \frac{v^2}{r},$$

taking into account  $v = \omega \cdot r$ ,  $r = (R + l \sin \alpha)$ , obtain

$$P = m \frac{r^2 \omega^2}{r} = m \omega^2 r = m \omega^2 (R + l \sin \alpha),$$

$$\frac{mg}{\cos \alpha} \sin \alpha = m \omega^2 (R + l \sin \alpha),$$

$$\omega^2 = \frac{g \sin \alpha}{(R + l \sin \alpha) \cos \alpha},$$

Then centrifugal force

$$P = m(R + l \sin \alpha) \frac{g}{\cos \alpha (R + l \sin \alpha)} \sin \alpha,$$

$$P = m g \frac{\sin \alpha}{\cos \alpha} = m g \cdot \operatorname{tg} \alpha.$$

Determine the necessary rotation speed to  $\alpha \rightarrow \pi/2$ , for this we use the ratio  $\omega^2 = \frac{g \sin \alpha}{(R + l \sin \alpha) \cos \alpha}$ , and construct a graph of this relationship (Fig.5).

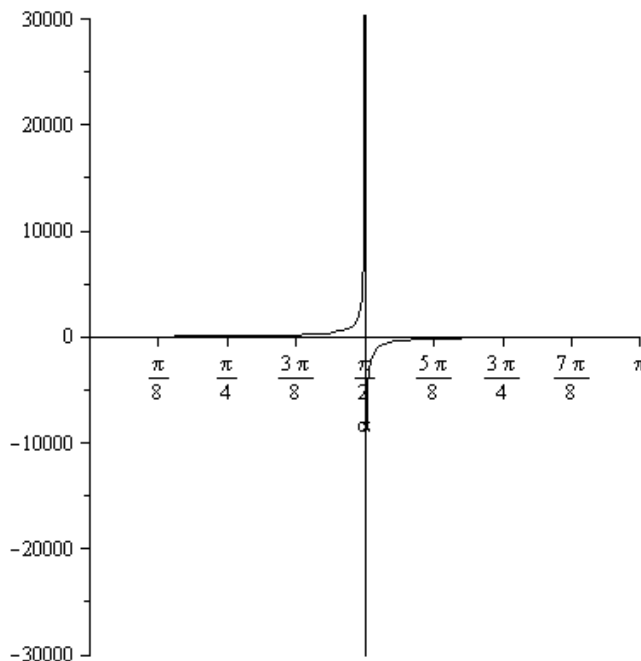

Fig. 5. Graphic representation of the solution

This graph shows that when  $\alpha = \pi/2$  maximum speed, but there is a break, which demonstrates the instability of cups rotation about an axis of rotation relative to the pins.

If we use the ratio  $\frac{g \cdot A}{\sqrt{(1 - A^2)}(R + l \cdot A)} - \omega^2 = 0$ , where the replacement to simplify is used  $\sin \alpha = A$ . Then the

operating characteristics centrifuge  $R = 11,5 \text{ cm}$ ,  $l = 2,07 \text{ cm}$ ,  $\omega = 470 \text{ sec}^{-1}$  obtain  $\sin \alpha = 0,9999999466$ , and the difference of angle  $\alpha$  from  $\pi/2$  there is only in the 5 mark. Therefore the working speed of rotation necessary to

ensure the position of cups in terms of maximum centrifugal force. It remains to determine the necessary conditions for stability of rotation and centrifuge of cups rotation.

Lagrange equation of the second kind is used

$$\frac{d}{dt} \frac{\partial L}{\partial \dot{\varphi}} - \frac{\partial L}{\partial \varphi} = Q_{\varphi},$$

$$\frac{d}{dt} \frac{\partial L}{\partial \dot{\psi}} - \frac{\partial L}{\partial \psi} = Q_{\psi},$$

where  $Q_{\psi}$ ,  $Q_{\varphi}$  – generalized forces,  $L = T - \Pi$  – Lagrange function,  $T$  – kinetic energy,  $\Pi$  – potential energy.

The potential energy of the system is determined by the potential energy cups. As the two of them

$$\Pi = 2mgl(1 - \cos \alpha),$$

where  $m$  – weight glass,  $l$  – distance from the axis of rotation (axis pins) to the center of gravity,  $\alpha$  – angle of the glass axis from the vertical axis. When you change the cup position the angle  $\alpha$  changes by  $\varepsilon$ , which is variable. In unstable motion  $\varphi = \alpha + \varepsilon$ , angular speed of rotation around the axis of the centrifuge cup during a stable regime  $\omega$ , and with unstable  $\dot{\psi} = \omega + \gamma$ .

The kinetic energy consists of kinetic energy of rotation of the plane cups for fixing to the motor shaft

$$T_k = \frac{1}{2} J_z \dot{\psi}^2$$

and the kinetic energy of cup, which in turn consists of a power rotational motion about the axis fixing two cups  $x$  (pin axis) with angular speed  $\dot{\varphi}$

$$T_1 = J_x \dot{\varphi}^2,$$

where  $J_x$  moment of inertia about the axis pin of cups and energy of motion due to rotation about the axis of the centrifuge

$$T_2 = m(R + l \sin \varphi)^2 \dot{\psi}^2.$$

Therefore

$$T = T_k + T_1 + T_2 = m(R + l \sin \varphi)^2 \dot{\psi}^2 + \frac{1}{2} J_z \dot{\psi}^2 + J_x \dot{\varphi}^2.$$

Consider that generalized force of braking the rotation around the axis fixing cup (moment)  $Q_{\varphi} = -\chi \dot{\varphi}$ , generalized force of braking the rotation around the axis of the centrifuge (moment) is of the moving moment  $M_1$ , consider that constant and braking moment proportional to the rotational speed  $-\nu \dot{\psi}$ ,  $Q_{\psi} = M_1 - \nu \dot{\psi}$ .

Lagrange function is  $L = T - \Pi$

$$L = m(R + l \sin \varphi)^2 \dot{\psi}^2 + \frac{1}{2} J_z \dot{\psi}^2 + J_x \dot{\varphi}^2 - 2mgl(1 - \cos \varphi).$$

At stable regime of motion  $\dot{\psi} = \omega$ ,  $\dot{\varphi} = \alpha$ ,  $Q_{\psi} = M_1 - \nu \omega = 0$ ,  $Q_{\varphi} = 0$ , then of Lagrange equations of the second kind obtain

$$\frac{d}{dt} \left[ 2m(R + l \sin \varphi)^2 \dot{\psi} + J_z \dot{\psi} \right] = (M_1 - \nu \dot{\psi}),$$

$$2J_x \ddot{\varphi} - 2m\dot{\psi}^2 (R + l \sin \varphi) l \cos \varphi + 2mgl \sin \varphi = -2\chi \dot{\varphi},$$

$$-2m\omega^2 (R + l \sin \varphi) l \cos \varphi + 2mgl \sin \varphi = 0,$$

$$\omega^2 = \frac{g \sin \alpha}{(R + l \sin \alpha) \cos \alpha}.$$

Stability is determined from the linear approximation. Obtain the differential equation of motion

$$\frac{d}{dt} \left[ 2m(R + l \sin \varphi)^2 \dot{\psi} + J_z \dot{\psi} \right] = (M_1 - \nu \dot{\psi}),$$

$$2J_x \ddot{\varphi} - 2m\dot{\psi}^2 (R + l \sin \varphi) l \cos \varphi + 2mgl \sin \varphi = -2\chi \dot{\varphi},$$

$$\left[ 2m(R + l \sin \varphi)^2 \ddot{\psi} + 4ml(R + l \sin \varphi) \dot{\psi} \dot{\varphi} \cos \varphi + J_z \ddot{\psi} \right] = M_1 - k\dot{\psi},$$

$$J_x \ddot{\varphi} - m\dot{\psi}^2 (R + l \sin \varphi) l \cos \varphi + mgl \sin \varphi = -\chi \dot{\varphi},$$

$$\varphi = (\alpha + \varepsilon), \quad \dot{\psi} = (\omega + \gamma),$$

$$\begin{aligned} & \left[ 2m(R+l\sin\varphi)^2 \ddot{\psi} + 4ml(R+l\sin\varphi) \dot{\psi} \dot{\varphi} \cos\varphi + J_{z_k} \ddot{\psi} \right] = M_1 - k\dot{\psi}, \\ & J_x \ddot{\varphi} - m\dot{\psi}^2 (R+l\sin\varphi) l \cos\varphi + mgl \sin\varphi = -\chi\dot{\varphi}, \\ & J_x (\ddot{\alpha} + \ddot{\varepsilon}) - ml(R+l\sin(\alpha+\varepsilon))(\omega+\gamma)^2 \cos(\alpha+\varepsilon) + mgl \sin(\alpha+\varepsilon) = -\chi(\dot{\alpha} + \dot{\varepsilon}), \\ & \left[ 2m(R+l\sin(\alpha+\varepsilon))^2 (\dot{\omega} + \dot{\gamma}) + 4ml(R+l\sin(\alpha+\varepsilon))(\omega+\gamma) \times \right. \\ & \quad \left. \times (\dot{\alpha} + \dot{\varepsilon}) \cos(\alpha+\varepsilon) + J_{z_k} (\dot{\omega} + \dot{\gamma}) \right] = M_1 - k(\omega+\gamma), \\ & 4m(R+l\sin\alpha) l \cos\alpha \cdot \omega\dot{\varepsilon} + v\gamma + (2(R+l\sin\alpha)^2 + J_z) \dot{\gamma} = 0. \end{aligned}$$

The equations decompose in Taylor series and hold the linear terms. Obtain

$$\begin{aligned} & J_x \ddot{\varepsilon} + (m(R+l\sin\alpha)^2 \sin\alpha \cdot \omega^2 - ml \cos^2\alpha \cdot \omega^2 + mgl \cos\alpha) \varepsilon - \\ & - 2m(R+l\sin\alpha) \omega \gamma \cos\alpha + \chi \dot{\varepsilon} = 0. \end{aligned}$$

Search a solution in the form  $\varepsilon = Ae^{\lambda t}$ ,  $\gamma = BAe^{\lambda t}$ , after simplification obtain the characteristic equation

$$\begin{aligned} & (-J_z J_x - 2R^2 J_x - 2l^2 J_x \sin^2\alpha - 4Rl J_x \sin\alpha) \lambda^3 + \\ & + (-4Rl \chi \sin\alpha - 2l^2 \chi \sin^2\alpha - J_z \chi - 2R^2 \chi - v J_x) \lambda^2 + \\ & + (-2R^3 m \omega^2 \sin\alpha - 6R^2 ml \omega^2 \sin^2\alpha + 2R^2 ml \omega^2 \cos^2\alpha - 4R^2 l mg \cos\alpha \sin\alpha - \\ & - J_z m \omega^2 R \sin\alpha - 2l^3 m \omega^2 \sin^4\alpha + 2l^3 m \omega^2 \sin^2\alpha \cos^2\alpha - 2l^3 mg \sin^2\alpha \cos\alpha - \\ & - 2R^3 mgl \cos\alpha - J_z ml \omega^2 \sin^2\alpha + J_z ml \omega^2 \cos^2\alpha - J_z ml g \cos\alpha - 8m^2 l^3 \omega^2 \cos^2\alpha \sin^2\alpha - \\ & - 8R^2 l m^2 \omega^2 \cos^2\alpha - 6Rl^2 m \omega^2 \sin^3\alpha + 4Rl^2 m \omega^2 \sin\alpha \cos^2\alpha - v \chi - 16m^2 l^2 R \omega^2 \cos^2\alpha \sin\alpha) \lambda - \\ & - vml \omega^2 \sin^2\alpha + vml \omega^2 \cos^2\alpha - vmgl \cos\alpha - vm \omega^2 R \sin\alpha = 0. \end{aligned}$$

Characteristic equation in  $\alpha = \pi/2$

$$\begin{aligned} & (-J_z J_x - 2R^2 J_x - 2l^2 J_x - 4Rl J_x) \lambda^3 + (-4Rl \chi - 2l^2 \chi - J_z \chi - 2R^2 \chi - v J_x) \lambda^2 + \\ & + (-2R^3 m \omega^2 - 6R^2 ml \omega^2 - J_z m \omega^2 R - 2l^3 m \omega^2 - J_z ml \omega^2 - 6Rl^2 m \omega^2 - v \chi) \lambda - \\ & - vml \omega^2 - vm \omega^2 R = 0. \end{aligned}$$

Its roots

$$\begin{aligned} \lambda_1 &= -\frac{v}{J_z + 2R^2 + 2l^2 + 4Rl}, \\ \lambda_2 &= -\frac{1}{2} \frac{\chi - \sqrt{\chi^2 - 4J_x m \omega^2 R - 4J_x ml \omega^2}}{J_x}, \\ \lambda_3 &= -\frac{1}{2} \frac{\chi + \sqrt{\chi^2 - 4J_x m \omega^2 R - 4J_x ml \omega^2}}{J_x}. \end{aligned}$$

## Conclusions

Movement will be stable in the case when the real part of the roots obtained is negative. From these results it follows that this occurs, provided that the value of  $v$  and  $\chi$  are nonzero. Otherwise, the first root is zero, and the second and third are imaginary. The values of  $v$  and  $\chi$  characterize generalized forces. From it follows that the motion will be stable only at presence of the resistance forces.

Determination of the dynamics of centrifuges provided an opportunity to determine the operating conditions centrifuges. In these zones vibration are practically absent so on the strength and durability of the processes influence only load endurance at maximum load and unload.

**Анотація.** Розглянуті конструктивні особливості сучасних центрифуг. Виявлено, що їх ротори мають рухомі елементи, які обертаються навколо горизонтальних осей. Розглянуто динаміку вказаних рухомих елементів. Використовуючи рівняння Лагранжа другого роду одержані диференціальні рівняння їх руху. Проведено моделювання візуалізації їх руху за допомогою програмного пакету ResurДуп. Результати досліджень отримані за допомогою пакету ResurДуп і аналітичним шляхом показали, що їх рух може бути не стійким, в тих положеннях, які є оптимальними з точки зору технологічного процесу. Отримані диференціальні рівняння не можуть бути проінтегровані в елементарних функціях, тому безпосередній аналіз руху складний. Внаслідок сказаного досліджено умови стійкості руху за лінійним наближенням. Одержані необхідні умови стійкості руху, які вимагаються від конструкції.

**Ключові слова:** Рух, стійкість, обертання, швидкість, коливання.

**Аннотация.** Рассмотрены конструктивные особенности современных центрифуг. Выявлено, что их роторы имеют подвижные элементы, которые вращаются вокруг горизонтальных осей. Рассмотрено динамику указанных подвижных элементов. Используя уравнение Лагранжа второго рода получены дифференциальные уравнения их движения. Проведено моделирование визуализации их движения с помощью программного пакета ResurDup. Результаты исследований полученные с помощью пакета ResurDup и аналитическим путем показали, что их движение может быть неустойчивым, в тех положениях, которые есть оптимальными с точки зрения технологического процесса. Полученные дифференциальные уравнения не могут быть проинтегрированы в элементарных функциях, поэтому непосредственный анализ движения сложный. Вследствие сказанного исследовано условия устойчивости движения за линейным приближением. Получены необходимые условия устойчивости движения, которые требуются от конструкции.

**Ключевые слова:** Движение, устойчивость, вращение, скорость, колебания.

#### Бібліографічний список використаної літератури

1. Бакаева Л.С., Суевалова Л.А. Статическое и динамическое уравновешивание вращающихся звеньев механизмов и машин, Хабаровск, Издательство ТОГУ 2008, 2с.
2. Бабенко А., Лавренко Я., Куренков М. Вплив гіроскопічних ефектів на коливання валу центрифуги. Вісник НТУУ «КПІ», Машинобудування. — К.: НТУУ «КПІ». - 2012. — Вып. 65. - с. 166-174.
3. Бабенко А.Е., Лавренко Я.И., Куренков Н.Н. Колебания центрифуги с учетом гироскопического эффекта. Загально-університетська науково-технічна конференція молодих вчених та студентів секція «Машинобудування» 2014 – К: НТУУ "КПІ", 2014. – с. 10-11.
4. Зейтман М.Ф., Кушурль М.Я. Изгибные колебания вертикальных роторов в гравитационном поле. Машиноведение, 1968, №5;
5. Маундер Л. Собственные частоты колебаний свободного гироскопа с упругим валом, установленного в кардановом подвесе. Механика, сб. перев. и обз. иностр. период. лит., 1961, №5 (69);

#### References

1. Bakaeva L.S., Suevalova L.A. Static and dynamic balancing of rotating parts of machines and mechanisms, Habarovsk, Publisher PNU 2008, 2p.
2. Babenko A., Lavrenko Ia., Kurenkov M. Journal of Mechanical Engineering of the National Technical University of Ukraine "Kyiv Politechnic Institute", 2013, no 65, pp. 166-174.
3. Babenko A.E., Lavrenko Ia.I., Kurenkov M.M. Fluctuations centrifuge with gyroscopic effect. All-university Scientific Conference of Young Scientists and Students section "Mechanical Engineering 2014". Kiev, 2014, p.10-11.
4. Zeytman M.F. Kushul M.J. Yzhybnye kolebaniya vertykalnyh rotorov v hravytatsyonnom pole [Vertical bending vibrations of rotors in a gravitational field]. Mashynovedenye, 1968, no 5;
5. Maunder L. Sobstvennyye chastoty kolebanij svobodnogo giroskopa s uprugim valom, ustanovlennogo v kardanovom podvese [Natural frequencies of the free gyroscope with elastic shaft mounted in gimbals]. Mechanics, Sat. Trans. and obz. foreign lang. period. lit., 1961, no 5 (69).

Подана до редакції 15.12.2014