

Level Monitoring System for Waste Oil Containers

An EPS@ISEP Project

M. Moura, M. Tasa, O. Olejniczak, N. Ahmad, A. Silva, B. Malheiro, M. Silva, M. C. Ribeiro, N. Caetano, P. Ferreira and P. Guedes

School of Engineering, Polytechnic Institute of Porto, Porto, Portugal

<http://www.eps2012-wiki4.dee.isep.ipp.pt>

epsatisep@gmail.com

Abstract—Waste oil recycling companies play a decisive role in our society. Competition among companies is tough and process optimization is essential for survival. By equipping oil containers with a level monitoring system that periodically reports the content level and alerts when it reaches a preset threshold, the oil recycling companies are able to streamline the waste oil collection process and, thus, reduce the operation costs while maintaining the quality of service. This paper describes the development of this level monitoring system by a team of four third-year students from different engineering backgrounds and nationalities. The team conducted a study of the state of the art, draw marketing and sustainable development plans and, finally, designed and implemented a prototype that continuously measures the container content level and sends an alert message as soon as it reaches the preset capacity.

Keywords— *project-based learning, teamwork, level monitoring, telemetry.*

I. INTRODUCTION

This paper reports on the design and development process of a level monitoring system for oil containers by a team of four third year students from diverse engineering and cultural backgrounds during the spring semester of 2012 [1].

The problem was proposed by Egi Energy, a local recycling company with 214 waste oil containers that relies on an inspection team to verify the level of the containers. The containers with a level above 50% of their capacity are scheduled for the next oil collection trip.

The initial project requirements were intentionally broad to allow the team to make design choices and find autonomously solutions. In particular, the requirements specified the development of a level monitoring system that should: (i) send automatically alert messages when the container is almost full; (ii) display the reported data via a Web interface; (iii) be robust; and (iv) comply with a 300 € budget.

Bearing in mind these ideas, this paper includes the following sections: introduction, state of the art, project development and, finally, the main conclusions of the work.

II. SUPPORT TECHNOLOGIES

Level measurement sensors are used to measure fluid or solid levels within a range. Generally, these sensors produce an

analogue output that directly correlates to the level in the container. To create a level management system, the level sensor output signal can be connected to a micro-controller.

The micro-controller can process the inputs from several sensors simultaneously and, additionally, send information to a communications module for transmission. If, for example, the communications module provides connection with the Internet, an administrator/manager can remotely access the sensor data and check for minimum/maximum level alerts [2].

A. Level Sensors

Level sensors detect the level of a substance in a container or in its natural form. The sensor can be continuous or detect given value. Continuous level sensors measure level within a specified range and determine the level of substance, while point-level sensors only indicate whether the substance is above or below the sensing point. There are several physical and application requirements that affect the selection of the level monitoring method for industrial and commercial processes. The physical requirements that condition the selection criteria include phase (liquid, solid or slurry), temperature, pressure, vacuum, dielectric constant of medium, density (specific gravity) of medium, agitation (action), acoustical or electrical noise, vibration, mechanical shock, tank or bin size and shape. Among the application constraints there are price, accuracy, appearance, response rate, ease of calibration or programming, physical size, mounting of the instrument, monitoring and robustness to environmental constraints, *etc.*

Ultrasonic devices are contactless sensors, *i.e.*, they are transceivers that send and receive signals as a radar or sonar [3]. Ultrasonic sensors (Figure 1) generate high frequency sound waves and measure the returned echo.



Figure 1 – Ultrasonic sensor.

Sensors calculate the time interval between sending the

signal and receiving the echo to determine the distance to an object. This technology can be used for measuring wind speed and direction (anemometer), the level of a tank and the speed through a fluid. To measure the liquid in a tank, the sensor measures the distance to the surface of the fluid (Figure 2).

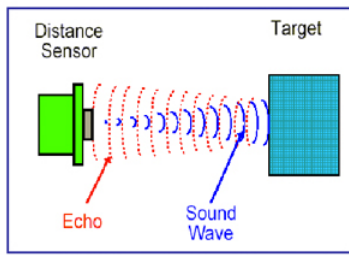

Figure 2 – Ultrasonic measuring.

Ultrasonic devices typically use a transducer, which generates sound waves in the ultrasonic range (above 18 kHz) by converting electric energy into sound, and, upon receiving the echo, convert the sound waves back into electric energy, which can be measured and displayed. This technology is limited by the shape of surfaces and the density or consistency of the material.

The ultrasonic HC-SR04 module will be used in this project to measure the internal level of the waste oil containers.

B. Battery

A battery is an electrochemical cell or enclosed and protected material. The battery can be charged electrically to provide a static potential for power or released electrical charge when needed [4]. The basic elements of a battery are an anode, a cathode and an electrolyte. The cathode is a metal that is combined with oxygen. The anode is a metal that would oxidize if it were allowed to and is more likely to oxidize than the metal that forms part of the cathode. There are different types of batteries: lead acid battery, Nickel-Cadmium (Ni-Cd) battery, Nickel-Metal Hydride (Ni-MH) battery and Lithium ion (Li-Ion) battery.

This project will use a lead acid battery since it is rechargeable, relatively inexpensive and can hold the charge for up to 3 years [5].

C. Micro-controller

A micro-controller is a small computer on a single integrated circuit containing a processor core, memory, and programmable input/output peripherals– see Figure 3.

Micro-controllers are designed for embedded applications, in contrast to the microprocessors used in personal computers or other general purpose applications [6]. Micro-controllers are used in automatically controlled products and devices such as automobile engine control systems, implantable medical devices, remote controls, office machines, appliances, power tools, toys and other embedded systems. By reducing the size and cost compared to a design that uses a separate microprocessor, memory and input/output devices, micro-controllers make it economical to digitally control even more

devices and processes.

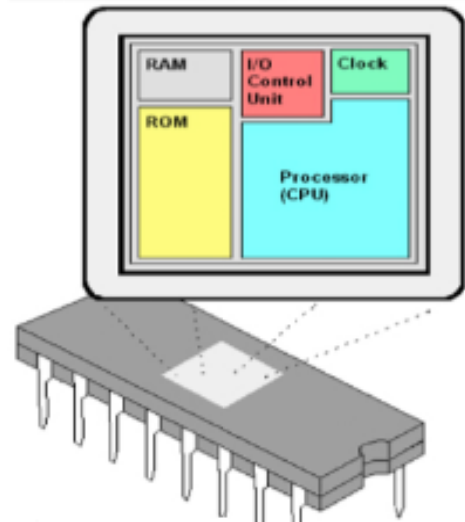

Figure 3 – Micro-controller main modules.

The Arduino Pro Mini (Figure 4) is the micro-controller selected to control all system components.

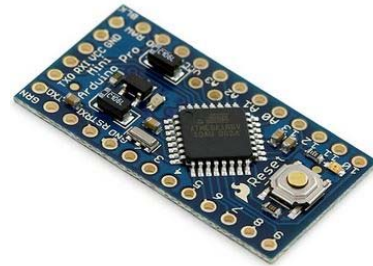

Figure 4 – Arduino Pro Mini micro-controller board.

D. Communication

Wireless communication allows the transfer of information between two or more points that are not physically connected. A Wi-Fi communication system will be used in this project to transfer data between the measurement system and the Web interface. Wi-Fi is a popular technology that allows an electronic device to exchange data wirelessly (using radio waves) over a computer network. The Wi Fi Alliance defines Wi-Fi as any "wireless local area network (WLAN) products that are based on the Institute of Electrical and Electronics Engineers (IEEE) 802.11 standards". However, since most modern WLAN are based on these standards, the term "Wi-Fi" is used in general English as a synonym for "WLAN" [7]. A device with a Wi-Fi interface can connect to the Internet via a wireless network access point. An access point (or hotspot) has a range of about 20 m indoor and a greater range outdoor. The hotspot coverage can comprise an area as small as a single room with walls that block radio waves or as large as many square miles — this is achieved by using multiple overlapping access points.

This project will adopt the WiFly Shield shown in the

Figure 5 to establish the data link between the container and the remote Web server.



Figure 5 – WiFly shield.

III. PROJECT DEVELOPMENT

A. Design

The level monitoring system must be placed inside the waste oil container and on top of the bin. Figure 6 illustrates the set up used for development and testing.



Figure 6 – Container with the level monitoring system.

Figure 7 displays how the components were placed inside an aluminium protective box, also developed by the team.



Figure 7 – Components layout inside the protective box.

B. System Architecture

The overall system architecture comprises two ultrasonic

sensors and control, communications, power and Web application modules (Figure 8).

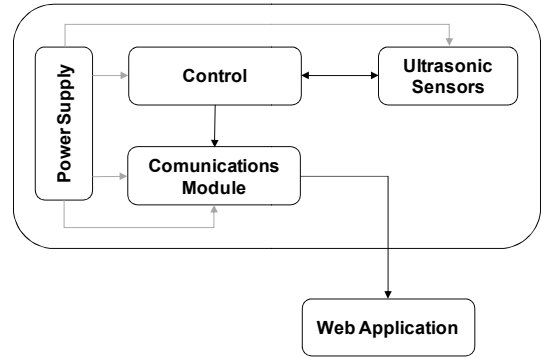

Figure 8 – System architecture.

C. Ultrasonic Sensors

The selected ultrasonic HC-SR04 module has a working range from 2 cm up to 400 cm with a ranging accuracy up to 3 mm. The module includes ultrasonic transmitters, receivers and a control circuit. To start ranging it requires a triggering high level signal for at least 10 μ s. The module automatically sends eight 40 kHz pulses and detects the pulse reflection. If the signal returns it will output a high signal with a duration corresponding to the time elapsed between the sending and returning of the ultrasonic signal.

D. Control

The main goal of the control system is to monitor the container level and communicate the sensor readings via a Wi-Fi connection to a remote Web application for storage. Users can then access this information via a Web browser.

The Arduino Pro Mini, which is the core of the control system, implements an infinite loop composed of ultrasonic ranging, reporting sensor levels to remote Web server and sleep stages – see Figure 9.

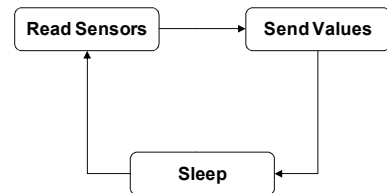

Figure 9 – Control loop diagram.

E. Schematics

Figure 10 shows the connections between the Arduino, the WyFly module, the two ultrasonic sensors, the battery, an XBee Explorer Regulated board, a Logic Level Converter board and a pull up resistor circuit.

The XBee Explorer Regulated board adapts the signal level between the Arduino Pro Mini (5 V signals) and the WiFly module (3.3 V signals).

The logical level converter (LLC) board, which converts signals from 5 V to 3.3 V, connects the Arduino virtual TX pin (pin 3) to the LLC module and the LLC directly to the WiFly

RX pin, supporting the serial connection between the WyFly and Arduino.

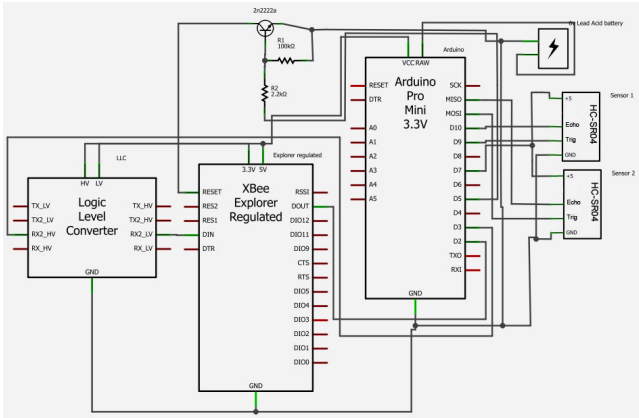

Figure 10 – Module connection schematics.

Finally, in order to work, the WiFly module requires a wake up input signal. The Wi-Fi board has 49 pins and the WiFly board has 20 pins and, as a result, the FORCE_AWAKE pin referred in the manual sheet is unconnected. This problem was solved by using the reset pin to wake up the WyFly module (not mentioned in the WiFly manual). This was achieved through an additional circuit with a transistor to pull the reset pin of the WiFly to ground and wake up the module, including a 100 kΩ resistor to make it stable and a 2.2 kΩ resistor to limit the current at the transistor base pin.

F. Web Interface

The Web interface was developed in Java and was deployed on the Apache Tomcat application server. Figure 11 displays the main page together with the container status page. The main page offers two options: to check the container status and to edit the container settings. The container status button redirects the user to the ShowSensorValues servlet. Thus, the servlet reads the file containing the container content level data and displays this information to the user.

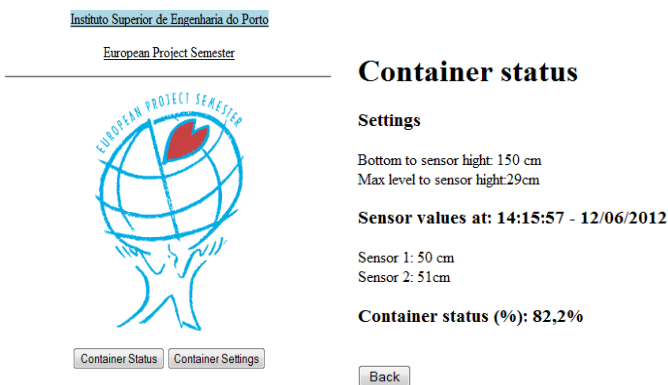

Figure 11 – Web interface.

This example shows the current container settings, the sensor values and the container level in percentage (%). The container settings button directs the user to another page where

he can define the threshold values for the container content level. This feature allows the system being able to handle different size containers.

IV. CONCLUSION

This project was developed by a team of four third year students from diverse engineering and cultural backgrounds during the spring semester of 2012.

The team spent the first weeks reviewing existing solutions and understanding the details of the project. The first activity was to identify, schedule and allocate the project tasks among team members. Then, the existing containers were analysed to determine where and how the monitoring system should be fixed and placed. The team discussed and reviewed in numerous brain storms sensors, communication modules, batteries and protective boxes options in order to select and acquire the set that fulfilled the requirements and did not exceed the predefined budget. The marketing plan and the sustainability aspects concerning of the project were also analysed [8][9]. The next step was to design, assemble and test the prototype. The Web interface application was, then, developed, allowing customers to use a Web browser to verify the container status. Finally, the team designed and built an aluminium box to hold and protect the monitoring system.

The team provided the client with a fully operational prototype for 100 € comprising two ultrasonic sensors, an Arduino Pro Mini, a Wi-Fi shield, a lead acid battery, an XBee Explorer Regulated board and a Logic Level Converter.

ACKNOWLEDGMENT

The authors thank Egi Energy for the container related data, the discussions and the insights provided.

REFERENCES

- [1] B. Malheiro, M. Silva, M. C. Ribeiro, P. Guedes, P. Ferreira, The European Project Semester at ISEP: Learning to Learn Engineering, Proceedings of the 1st International Conference of the Portuguese Society for Engineering Education, Porto, 2013.
- [2] Milan Verle, PIC Microcontrollers, MikroElektronika, 2008. Available at <http://www.mikroe.com/eng/chapters/view/1/introduction-world-of-microcontrollers/>.
- [3] Thunder World, Truck Radar Parking Sensor, 2012. Available at http://thunderworld.in/truck_radar_parking_sensor.
- [4] Freecircuits, Basics of Batteries and Cells, 2012. Available at <http://freecircuits.org/2011/07/basics-batteries-cells>.
- [5] First Nation Battery, Industrial Lead Acid Batteries: Types and their selection, 2004. Available at <http://www.battery.co.za/download/dl/IndustrialBatteriesTypes&Selection.pdf>.
- [6] Circuitstoday, Microcontrollers, 2011. Available at <http://www.circuitstoday.com/basics-of-microcontrollers>.
- [7] Webopedia, Wi-Fi, 2011. Available at <http://www.webopedia.com/TERM/W/Wi-Fi.html>.
- [8] Jukka Hoffrén, Strengths and Weaknesses of Eco-efficiency, 2012. Available at http://koti.mbnet.fi/~jukkah/EE_analysis_JH.pdf.
- [9] Tonolli Canada, Recycling for a Better Environment, 2012. Available at <http://www.tonolli.ca/recycling-batteries>.