



A semi-Lagrangian scheme for mean curvature motion with nonlinear Neumann conditions

Yves Achdou, Maurizio Falcone

► **To cite this version:**

Yves Achdou, Maurizio Falcone. A semi-Lagrangian scheme for mean curvature motion with nonlinear Neumann conditions. 2011. <hal-00559382>

HAL Id: hal-00559382

<https://hal.archives-ouvertes.fr/hal-00559382>

Submitted on 25 Jan 2011

HAL is a multi-disciplinary open access archive for the deposit and dissemination of scientific research documents, whether they are published or not. The documents may come from teaching and research institutions in France or abroad, or from public or private research centers.

L'archive ouverte pluridisciplinaire **HAL**, est destinée au dépôt et à la diffusion de documents scientifiques de niveau recherche, publiés ou non, émanant des établissements d'enseignement et de recherche français ou étrangers, des laboratoires publics ou privés.

A semi-Lagrangian scheme for mean curvature motion with nonlinear Neumann conditions

Yves Achdou ^{*}, Maurizio Falcone [†]

January 11, 2011

Abstract

A numerical method for mean curvature motion in bounded domains with nonlinear Neumann boundary conditions is proposed and analyzed. It consists of a semi-Lagrangian scheme in the main part of the domain as proposed by Carlini, Falcone and Ferretti, combined with a finite difference scheme in small layers near the boundary to cope with the boundary condition. The consistency and monotonicity properties of the new scheme are studied for nonstructured triangular meshes in dimension two. Details on the implementation are given. Numerical tests are presented.

AMS Classification: 65M06, 65M12, 49L25.

Keywords: Hamilton Jacobi equations, front propagation, Neumann boundary conditions, convergence, viscosity solutions, triangular meshes.

1 Introduction

We consider the mean curvature equation

$$\frac{\partial u}{\partial t} - \text{trace} \left(\left(I - \frac{Du \otimes Du}{|Du|^2} \right) D^2 u \right) = 0 \quad \text{in } \Omega \times (0, T), \quad (1)$$

where Ω is a bounded domain of \mathbb{R}^n with a $W^{3,\infty}$ boundary. The partial differential equation (1) can also be written

$$\frac{\partial u}{\partial t} - \Delta u + \frac{(D^2 u Du, Du)}{|Du|^2} = 0 \quad \text{in } \Omega \times (0, T), \quad (2)$$

or

$$\frac{\partial u}{\partial t} - \text{div} \left(\frac{Du}{|Du|} \right) |Du| = 0 \quad \text{in } \Omega \times (0, T). \quad (3)$$

Here, Du stands for the space gradient, $D^2 u$ for the Hessian matrix of second space derivatives of u and for any vector $p \in \mathbb{R}^n$, $p \otimes p = pp^T$. The partial differential equation (1) is complemented with an initial condition

$$u(x, 0) = u_0(x), \quad \text{for } x \in \Omega, \quad (4)$$

^{*}UFR Mathématiques, Université Paris 7, Case 7012, 175 rue du Chevaleret, 75013 Paris, France and UMR 7598, Laboratoire Jacques-Louis Lions, F-75005, Paris, France. achdou@math.jussieu.fr

[†]Dipartimento di Matematica, Università Roma "La Sapienza", Piazzale A. Moro 2, I-00185 Roma, falcone@mat.uniroma1.it

and with the nonlinear Neumann condition

$$\frac{\partial u}{\partial n} = \theta |Du| \quad \text{on } \partial\Omega \times (0, T), \quad (5)$$

where θ is Lipschitz continuous function with $|\theta(x)| \leq \bar{\theta} < 1$.

To put our work into perspective, let us recall that Crandall and Lions [12] have developed an analysis of explicit finite difference schemes for a class of possibly degenerate parabolic equations of the form:

$$u_t - \text{trace}(\Theta(x, Du)\Theta(x, Du)^T D^2u) = 0 \quad \text{for } t > 0, x \in \mathbb{R}^n. \quad (6)$$

Here, $\Theta(x, p)$ is a $N \times M$ matrix valued function of $(x, p) \in \mathbb{R}^n \times \mathbb{R}^n$ and A^T denotes the transpose of a matrix A . Note that the integer M is arbitrary and the equation is degenerate if $\Theta(x, p)$ is not invertible.

Our particular case (1) corresponds to the choice

$$\Theta(x, p) = \Theta(p) = I - \frac{p \otimes p}{|p|^2}, \quad (7)$$

(where $|\cdot|$ denotes the Euclidean norm). It is well known that in our case Θ is discontinuous at $p = 0$ and degenerate for $p \neq 0$. Since $\Theta(p)^2 = \Theta(p)$ and $\Theta(p) = \Theta(p)^T$, $\Theta(p)$ is a projection matrix, which in fact projects the diffusion orthogonally with respect to the gradient.

We will work in the framework of level set methods using the theory of viscosity solutions, which allows to deal with both singularities of solutions and degeneracies of the parabolic operator (see [2] and [10] for an introduction to this theory). Existence and uniqueness for the viscosity solutions to the Cauchy problem in \mathbb{R}^n have been proved independently by Evans and Spruck[15] and by Chen, Giga and Goto [8]. Starting from those pioneering papers, the last years have witnessed a great development of the theory about curvature related flows, as well as its application to various fields like phase transitions, image processing, fluid dynamics, material science and crystallography (see the books [26] and [23] for a review of interesting applications and simulations). We refer the interested reader to the lecture notes [18], [29] for the theory of viscosity solutions for surface evolution equations. Viscosity solutions of the boundary value problem (1)(4)(5) have been studied by Barles[3], see also Ishii and Ishii [20], Giga et al[19].

Naturally, several attempts have been made to construct reliable approximation schemes. In particular, Evans [14] and Barles-Georgelin [4] proved the convergence of semi-discrete approximations (only time is discretized). Finite difference schemes have been proposed by Osher and Sethian in the late eighties, see [24] but the proof of convergence results for fully discrete approximation schemes came later with the paper by Crandall and Lions [12]. Let us also mention that the approximation of the Mean Curvature Flow has been also tackled via finite element methods by several authors, although this approach usually suffers from the degeneracy of the second order operator. The main convergence results related to this approach which can take into account also the onset of singularities can be found in the papers by Nchetto and Verdi [22] and Dziuk and Deckelnick [13].

In this work, we aim at modifying the semi-Lagrangian scheme introduced by Carlini et al in the recent article [7] for (1) with no boundary conditions. The idea is to combine the previously mentioned scheme with a finite difference scheme for (5) in thin layers near $\partial\Omega$. Note that a first version of the semi-Lagrangian scheme had been introduced in [17] where consistency was proved assuming that the gradient of the solution could not vanish, i.e., in the nonsingular case. The second version proposed in [7] can handle the singular case. For the latter, consistency, monotonicity (in a generalized sense), and thus convergence were proved. The main ingredient of the proof was a generalization of the result obtained for monotone schemes by Barles and

Souganidis in [5].

In [7], the semi-Lagrangian scheme has only been defined for uniform Cartesian grids. Since we wish to deal with general domains, we have decided to use triangular meshes. Hence, compared to [7], we need two more ingredients: the use of triangular meshes to accurately approximate the geometry and a local solver in small regions near $\partial\Omega$ for a first order Hamilton-Jacobi equation corresponding to the Neumann boundary condition. We will focus on the two-dimensional case (i.e. $n = 2$), for simplicity and because it is possible to obtain a convergence result in this case, but the scheme presented here can be used for three dimensional problems with tetrahedral meshes. We should mention that relatively few numerical schemes for Hamilton-Jacobi equation on nonstructured meshes have been proposed in the literature, probably because the hyperbolic nature of these equations and the link between viscosity solutions and entropy solutions for conservation laws have supported the use of structured grids and finite difference schemes: we mention the book of Sethian [26], and [1] in which Abgrall has proved convergence for a scheme based on triangular meshes for Hamilton-Jacobi equations of the first order. Note that semi-Lagrangian schemes in the class proposed by Falcone and Ferretti in [16] do not require structured grids and can be applied also to stationary problems. For example, in [25] a first order semi-Lagrangian method on unstructured grids is used to solve the first order Hamilton-Jacobi equation corresponding to the Shape-from-Shading problem. However, we preferred to use for the implementation of the boundary condition (5) a Godunov type scheme on the triangular mesh, and, to be more precise, an adaptation of the fast sweeping method for the eikonal equation on structured meshes originally proposed by Zhao [30].

We will extend some of the theoretical results contained in [7] to deal with the case of an open bounded domain Ω with Neumann boundary conditions. The general framework for our convergence result is the theory of viscosity solutions and, in particular, the results that have been established by Barles [3] (see also Ishii and Ishii [20]).

The paper is organized as follows: In Section 2 we introduce our notations, present the scheme and give some hints for the implementation. Section 3 is devoted to the analysis of consistency and monotonicity; these two basic properties are necessary to establish convergence via the Barles-Souganidis abstract theorem [5]. In particular, in § 3.1, we prove that the scheme is consistent. In § 3.2, we present an analysis of monotonicity for a regularization based on the addition of a viscosity term, as well as a convergence result for this regularized version of the scheme. In Section 4, we report about some numerical results.

2 A numerical method in dimension two

An ingredient of the numerical method is the semi-Lagrangian scheme proposed in [7] on a triangular mesh. The semi-Lagrangian method consists essentially of applying a finite difference scheme along a characteristic curve. The spatial step used in the semi-Lagrangian method will be of the order of δ . Therefore, for a node ξ whose distance to the boundary is smaller than δ , it is possible that the points needed by the scheme (the feet of the characteristics) fall out of the domain Ω . This is the essential reason why we choose to distinguish thin layers near the boundary (whose width is of the order of δ) in which we will use a finite difference scheme for the boundary condition (5) rather than (1).

In § 2.1, we start by carefully defining the geometry, the triangular mesh and the thin layers near the boundary. We recall some basic facts on finite elements on triangular meshes in § 2.2, and we present the scheme in § 2.3.

2.1 A nonstructured mesh

The domain Ω Consider $(Y^\ell)_{\ell=0,\dots,L}$, $L+1$ simply connected bounded domains of \mathbb{R}^2 such that $Y^\ell \subset\subset Y^0$ if $1 \leq \ell \leq L$ and $\overline{Y^\ell} \cap \overline{Y^j} = \emptyset$ if $1 \leq j < \ell \leq L$. Call $(\Gamma^\ell)_{\ell=0,\dots,L}$ the boundaries of $(Y^\ell)_{\ell=0,\dots,L}$. The curves Γ^ℓ are closed, connected and disjoint. We assume that Γ^ℓ is parameterized by $(\phi_1^\ell(\theta), \phi_2^\ell(\theta))$ where ϕ_1^ℓ and ϕ_2^ℓ are two smooth real valued functions defined in \mathbb{T} the unit one-dimensional torus. We assume that $(\phi_1^0(\theta), \phi_2^0(\theta))$ turns counterclockwise as θ grows from 0 to 1, and that for $1 \leq \ell \leq L$, $(\phi_1^\ell(\theta), \phi_2^\ell(\theta))$ turns clockwise as θ grows from 0 to 1. Call $\Omega = Y^0 \setminus \cup_{\ell=1}^L \overline{Y^\ell}$. We have $\partial\Omega = \cup_{\ell=0}^L \Gamma^\ell$.

The curvilinear abscissa s^ℓ is given by $s^\ell(0) = 0$ and $\frac{ds^\ell}{d\theta}(\theta) = \sqrt{\left(\frac{d\phi_1^\ell}{d\theta}(\theta)\right)^2 + \left(\frac{d\phi_2^\ell}{d\theta}(\theta)\right)^2}$. Call $S^\ell = s^\ell(1)$. There exist two smooth S^ℓ -periodic real valued functions x_1^ℓ and x_2^ℓ such that $s \rightarrow (x_1^\ell(s), x_2^\ell(s))$ is a parametrization of Γ^ℓ . The exterior normal to $\partial\Omega$ at $(x_1^\ell(s), x_2^\ell(s))$ is $n(s) = \left(\frac{dx_2^\ell}{ds}(s), -\frac{dx_1^\ell}{ds}(s)\right)$.

The mesh Let us consider a family (\mathcal{T}_h) of regular and quasiuniform triangular meshes of Ω . More precisely, \mathcal{T}_h , is a set of triangles such that

- all the nodes lie in $\overline{\Omega}$.
- the intersection of two distinct triangles is either empty or a common vertex or a whole common edge of both triangles.
- the diameters of any triangle in \mathcal{T}_h and of its inscribed circle are both of the order of h .
- We define the open set Ω_h such that $\overline{\Omega_h} = \bigcup_{\tau \in \mathcal{T}_h} \tau$ and we call $(\xi_i)_{1 \leq i \leq N_h}$ the nodes of \mathcal{T}_h . We assume that for all i , $1 \leq i \leq N_h$, $\xi_i \in \partial\Omega_h$ if and only if $\xi_i \in \partial\Omega$, that for each $\ell = 0, \dots, L$, there are nodes of \mathcal{T}_h lying on Γ^ℓ , and that the Hausdorff distance between $\partial\Omega$ and $\partial\Omega_h$ is of the order of h^2 .
- We assume that $\partial\Omega_h = \cup_{\ell=0}^L \Gamma_h^\ell$ where Γ_h^ℓ is a non empty polygonal line whose vertices are the nodes of \mathcal{T}_h lying on Γ^ℓ .

Thin layers near $\partial\Omega$ Consider another positive number δ such that $\delta/h > N$, where N is fixed positive integer. Let ω^ℓ be the ring shaped domain defined by

$$\overline{\omega^\ell} := \{x \in \overline{\Omega_h}, d(x, \Gamma^\ell) \leq \delta + h\}.$$

Since the thickness of ω^ℓ is of the order of δ , $\omega^\ell \subset \Omega_h$ and $\overline{\omega^\ell} \cap \overline{\omega^k} = \emptyset$, $k \neq \ell$ if δ is small enough. The parameter δ will be the step used in the semi-Lagrangian scheme, in which, for a node ξ , one needs to evaluate a function at two points located at a distance δ of ξ on an approximate characteristic curve. In ω^ℓ , this scheme cannot be applied, so we use instead a finite difference scheme for (5).

Definition 1 (Internal and boundary nodes) *We say that a vertex ξ of \mathcal{T}_h is a strongly internal mesh node if ξ does not belong to $\cup_{\ell=0}^L \overline{\omega^\ell}$. In the opposite case, we say that ξ is a boundary node.*

Since the Hausdorff distance between $\partial\Omega$ and $\partial\Omega_h$ is of the order of h^2 , if δ is small enough, then for all the strongly internal mesh nodes ξ ,

$$B(\xi, \delta) \subset \overline{\Omega_h}. \quad (8)$$

Definition 2 We define the set of nodes Ξ_h^ℓ by

$$\Xi_h^\ell := \{\xi; \xi \text{ is a boundary node lying in } \overline{\omega^\ell}\}.$$

If ξ is a boundary node, then there exists a unique ℓ , $0 \leq \ell \leq L$ such that $\xi \in \Xi_h^\ell$.

Hereafter, we assume that δ is small enough such that for any $\xi \in \Xi_h^\ell$, the projection $\pi^\ell(\xi)$ of ξ on Γ^ℓ is uniquely defined as the point on Γ^ℓ which minimizes the distance to ξ . The distance of ξ to Γ^ℓ is then $d(\xi, \Gamma^\ell) = |\xi - \pi^\ell(\xi)|$. Similarly, we can extend the definition of the normal vector to Γ^ℓ to the nodes in Ξ_h^ℓ by : for all $\xi \in \Xi_h^\ell$, $n^\ell(\xi) = n^\ell(\pi(\xi))$. We can also define $s^\ell(\xi)$ as the curvilinear abscissa of $\pi^\ell(\xi)$.

In practice, the set of nodes Ξ_h^ℓ and then $\pi^\ell(\xi)$ for $\xi \in \Xi_h^\ell$ can be obtained in different ways. Without going to far into details, one can

- either solve eikonal equations on a much finer grid (a very fine uniform grid for example).
- or construct triangulations of regions approximating $\{x \in \Omega, d(x, \Gamma^\ell) \leq \delta + h\}$ with a high resolution in the tangential direction to Γ^ℓ , and perform a search method to see if a node ξ of \mathcal{T}_h belongs to Ξ_h^ℓ , and if yes to compute $\pi^\ell(\xi)$ (by dichotomy for instance).

The pair $(d(\xi, \Gamma^\ell), s^\ell(\xi))$ is closed to an orthogonal system of coordinates in $\overline{\omega^\ell}$, and the nodes $\xi \in \Xi_h^\ell$ can be sorted by ordering either $(d(\xi, \Gamma^\ell), s^\ell(\xi))$ or $(s^\ell(\xi), d(\xi, \Gamma^\ell))$ lexicographically. These two kinds of indexing will prove useful for what follows.

As an example, assume that the domain Ω has a hole, so $L = 1$; its outer boundary is parametrized by

$$x_1 = 2 \cos(2\pi t) + 0.75 \cos(4\pi t), \quad x_2 = 2 \sin(2\pi t) + 0.75 \sin(4\pi t),$$

and its inner boundary is the unit circle of equation $|x - (0.5, 0)| = 1$. We take $h \sim 0.06$ and $\delta \sim 0.3$. The mesh and the two layers near the boundaries are displayed in Figure 1: there are two lines around the layers' boundaries. Note that we have chosen a large value of δ for the layers to be visible.

2.2 Piecewise linear finite elements

For what follows, we need to define the space of functions $V_h = \{v \in \mathcal{C}^0(\overline{\Omega_h}), v|_\tau \text{ is affine}, \forall \tau \in \mathcal{T}_h\}$. For $i = 1, \dots, N_h$, let $\lambda_i \in V_h$ be the nodal basis function associated to node ξ_i , i.e. $\lambda_i(\xi_j) = \delta_{i,j}$, $\forall j = 1, \dots, N_h$.

The finite element method for the heat equation in Ω_h with Neumann conditions on $\partial\Omega_h$ involves the stiffness matrix $A \in \mathbb{R}^{N_h \times N_h}$ and the mass matrix $M \in \mathbb{R}^{N_h \times N_h}$, which will be useful below:

$$A_{i,j} = \int_{\Omega_h} D\lambda_i(x) \cdot D\lambda_j(x) dx, \quad M_{i,j} = \int_{\Omega_h} \lambda_i(x) \lambda_j(x) dx. \quad (9)$$

It is well known that if all the triangles containing a vertex ξ_i have acute angles then $A_{i,j} \leq 0$, for all $j \neq i$. Similarly, if all the triangles in a mesh \mathcal{T}_h have all acute angles, then the resulting matrix A is a M-matrix, (there is a discrete maximum principle).

We will sometimes make the following assumption

Assumption 1 For all the strongly internal nodes ξ_i , all the triangles containing ξ_i have acute angles, uniformly bounded away from 0 and $\pi/2$. In such a case, if $\xi_i \neq \xi_j$ are two vertices of a triangle $t \in \mathcal{T}_h$ containing a strongly internal node, then

$$A_{i,j} \leq -\alpha, \quad (10)$$

for a positive constant α .

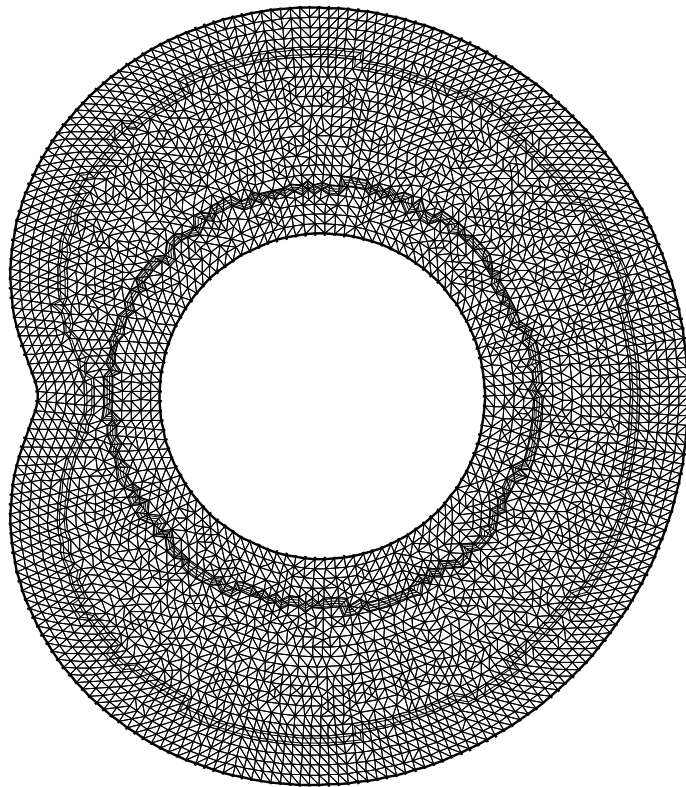

Figure 1: The domain Ω , the mesh and the two layers near the boundaries

Remark 1 *In dimension two, if $\partial\Omega$ is smooth, it is always possible to construct such families of triangulations, by adding so-called Steiner nodes to the triangulation if necessary.*

For what follows, we will need the following definitions:

- For a real valued function w defined at the nodes of \mathcal{T}_h , we call $\mathcal{I}_h[w]$ the piecewise affine interpolation of w .
- For a mesh node ξ_i , let $\mathcal{T}_{h,i}$ be the set of triangles τ of \mathcal{T}_h such that ξ_i is a vertex of τ , and ω_{ξ_i} be the polygonal domain obtained as the union of the triangles in $\mathcal{T}_{h,i}$. We also define $\Sigma_i = \{j : \xi_j \text{ is a vertex of } \omega_{\xi_i}\}$.

2.3 The scheme

We approximate $u(\xi_i, n\Delta t)$, $1 \leq i \leq N_h$ by u_i^n computed by a discrete numerical scheme. The proposed schemes differs according to the previously defined regions. At the strongly internal nodes, we will use the semi-Lagrangian scheme advocated by Carlini et al [7] whereas in the thin regions near $\partial\Omega$, namely $\overline{\omega^\ell}$, $\ell = 0, \dots, L$, we will use a finite difference scheme for the equation

$$n^\ell(x) \cdot Du(x) - \theta |Du(x)| = 0. \quad (11)$$

Note that the width of that region is controlled by the parameters δ and h according to the definition (2.1).

2.3.1 The scheme in $\overline{\omega^\ell}$, $\ell = 0, \dots, L$

The nonlinear Neumann condition (11) is not only imposed at the nodes on $\partial\Omega^h$, but also at all the boundary nodes in $\overline{\omega^\ell}$. Consider the steady state Hamilton-Jacobi equation (11), and a monotone and consistent scheme for (11) at the nodes in Γ_h^ℓ which we write

$$\mathcal{B}^\ell(\xi_i, u_i, [u]_\ell, [[u]]) = 0, \quad \text{for all } i \text{ such that } \xi_i \in \Xi_h^\ell \quad (12)$$

where

$$\begin{aligned} [u]_\ell &= \{u_j, 1 \leq j \leq N_h, j \neq i, \xi_j \in \Xi_h^\ell\}, \\ [[u]] &= \{u_j, 1 \leq j \leq N_h, \xi_j \text{ is strongly internal}\}. \end{aligned}$$

For example, a first order Godunov like scheme can be used, see §2.4. Note that such an upwind scheme written at a given node $\xi \in \Xi_h^\ell$ may involve values at strongly internal mesh nodes. The values u_i^{n+1} , for i such that $\xi_i \in \Xi_h^\ell$ are computed by solving the system of nonlinear equation

$$\mathcal{B}^\ell(\xi_i, u_i^{n+1}, [u^{n+1}]_\ell, [[u^n]]) = 0, \quad \text{for all } i \text{ such that } \xi_i \in \Xi_h^\ell. \quad (13)$$

The monotonicity of the scheme implies the existence and uniqueness of a solution, see [9]. System (13) is solved by a fast sweeping method as in [30], which consists of combining several Gauss-Seidel methods corresponding to different orderings of the nodes in Ξ_h^ℓ introduced in Definition 2; this is why it is useful to have having several lexicographic orderings of the nodes in Ξ_h^ℓ , all related to a close to orthogonal systems of coordinates (see § 2.1 and § 2.4 for more details on the implementation).

2.3.2 The scheme at the strongly internal nodes

At the strongly internal nodes, we essentially use the scheme proposed by Carlini et al [7], with a slight modification due to the unstructured character of the present mesh.

An important ingredient of the scheme is a linear discrete gradient operator: let ξ_i be an internal mesh node. For any function v whose values at the mesh nodes is known, the discrete gradient of v at ξ_i is defined by

$$[D_h v](\xi_i) = \begin{pmatrix} \sum_{j \in \Sigma_i} d_{i,1}^j v(\xi_j) \\ \sum_{j \in \Sigma_i} d_{i,2}^j v(\xi_j) \end{pmatrix}, \quad (14)$$

We assume that if v is constant, then $D_h v = 0$ and that the order of the approximation is $q > 0$, i.e. if Φ is a smooth function, then

$$\max_i |[D_h \Phi](\xi_i) - D\Phi(\xi_i)| \leq Ch^q. \quad (15)$$

Example Let v be a continuous function defined on Ω_h , such that for all $\tau \in \mathcal{T}_h$, $v|_\tau$ is affine. Define the discrete gradient $[D_h v](\xi_i)$ by

$$[D_h v](\xi_i) = \sum_{\tau \in \mathcal{T}_{h,i}} \frac{|\tau|}{|\omega_{\xi_i}|} D(v|_\tau), \quad (16)$$

with the notation defined at the end of § 2.2. For a function defined at the mesh nodes, we set

$$[D_h v](\xi_i) = \sum_{\tau \in \mathcal{T}_{h,i}} \frac{|\tau|}{|\omega_{\xi_i}|} D(\mathcal{I}_h[v]|_\tau). \quad (17)$$

where \mathcal{I}_h is the Lagrange interpolation operator on piecewise affine functions. Note that $[D_h v](\xi_i)$ can also be written

$$|\omega_{\xi_i}| [D_h v](\xi_i) = \begin{pmatrix} \int_{\omega_{\xi_i}} D\mathcal{I}_h[v] \cdot e_1 \\ \int_{\omega_{\xi_i}} D\mathcal{I}_h[v] \cdot e_2 \end{pmatrix} = \begin{pmatrix} \sum_{j \neq i} v_j \int_{\omega_{\xi_i}} D\lambda_j \cdot e_1 \\ \sum_{j \neq i} v_j \int_{\omega_{\xi_i}} D\lambda_j \cdot e_2 \end{pmatrix}. \quad (18)$$

It can be proved that this is a first order approximation, i.e. $q = 1$ in (15). Moreover, it is well known that if the mesh is uniform and made with right isosceles triangles, then the approximation is superconvergent, i.e. $q = 2$.

Remark 2 *In general, it is possible to construct second order approximations of the gradient of v at ξ_i by linear combinations of the values $v(\xi_j)$, where ξ_j are the vertices of ω_{ξ_i} . The idea is to use a third order interpolation operator of v on ω_{ξ_i} (exact on second order polynomials). Such an interpolation is not unique in general.*

For each $i = 1, \dots, N_h$, set

$$D_i^n = [D_h u^n](\xi_i). \quad (19)$$

Given two positive numbers C and s , the two sets of indices \mathcal{J}_1^n and \mathcal{J}_2^n are defined as follows:

$$\begin{aligned} \mathcal{J}_1^n &= \{i = 1, \dots, N_h; \xi_i \text{ is strongly internal and } |D_i^n| \geq Ch^s\}, \\ \mathcal{J}_2^n &= \{i = 1, \dots, N_h; \xi_i \text{ is strongly internal and } |D_i^n| < Ch^s\}. \end{aligned} \quad (20)$$

If $i \in \mathcal{J}_1^n$, then we introduce the unit vector Θ_i^n by

$$\Theta_i^n = \frac{1}{|D_i^n|} \begin{pmatrix} -(D_i^n)_2 \\ (D_i^n)_1 \end{pmatrix} \quad (21)$$

and we compute u_i^{n+1} by

$$u_i^{n+1} = u_i^n + \frac{\Delta t}{\delta^2} (\mathcal{I}_h[u^n](\xi_i + \delta\Theta_i^n) + \mathcal{I}_h[u^n](\xi_i - \delta\Theta_i^n) - 2u_i^n), \quad i \in \mathcal{J}_1^n, \quad (22)$$

which is possible thanks to (8).

Remark 3 *It is useful to recall that the mapping $\Theta : p \mapsto \frac{1}{|p|}(p_2, -p_1)^T$ is differentiable in $\mathbb{R}^2 \setminus \{0\}$ and that its Jacobian matrix at $p \neq 0$ is*

$$D\Theta(p) = \begin{pmatrix} -\frac{p_1 p_2}{|p|^3} & \frac{p_1^2}{|p|^3} \\ -\frac{p_2^2}{|p|^3} & \frac{p_1 p_2}{|p|^3} \end{pmatrix},$$

so the Frobenius norm of $D\Theta(p)$ equals $1/|p|$.

Remark 4 *Concerning the implementation of (22), the main difficulty is to locate the triangle containing the feet of the (generalized) characteristics, namely $\xi_i \pm \delta\Theta_i^n$ in order to compute the value of the solution at that point via a local interpolation operator. Trying to locate $z \equiv \xi_i + \delta\Theta_i^n$ for example, one can start from a triangle containing ξ_i and construct inductively a sequence (τ_m) of triangles closer and closer to z as follows: if τ_m contains z , then stop. Else, call $(A_j)_{j=1,2,3}$ the vertices of τ_m and $(w_j)_{j=1,2,3}$ the related barycentric coordinates. Compute the numbers $w_j(z)$. If there exists only one index j such that $w_j(z) < 0$, say $j = 1$, then τ_{m+1} is the triangle sharing the edge $A_2 A_3$ with τ_m . If on the contrary, we have $w_j(z) < 0$ for two indices j , say $j = 1$ and $j = 2$, then choose τ_{m+1} as one of the two triangles sharing with τ_m the edges $A_1 A_3$ or $A_2 A_3$.*

The values u_i^{n+1} , $i \in \mathcal{J}_2^n$ remain to be defined. We set

$$u_i^{n+1} = -\frac{\sum_{j \neq i} A_{ij} u_j^n}{A_{ii}} = \frac{\sum_{j \neq i} A_{ij} u_j^n}{\sum_{j \neq i} A_{ij}}, \quad i \in \mathcal{J}_2^n, \quad (23)$$

where the matrix A has been defined in (9). We can also write (23) in the following way:

$$\left(\sum_{j=1}^{N_h} M_{ij} \right) (u_i^{n+1} - u_i^n) = -\epsilon_i \Delta t \sum_{j=1}^{N_h} A_{ij} u_j^n, \quad (24)$$

where

$$\epsilon_i = \frac{\left(\sum_{j=1}^{N_h} M_{ij} \right)}{\Delta t A_{ii}}.$$

We see that u_i^{n+1} is found by performing one iteration of an explicit Euler scheme for a parabolic equation of the form

$$\frac{\partial w}{\partial t} - \epsilon(x) \Delta w = 0, \quad (25)$$

with mass lumping (we have replaced the mass matrix which is involved in the Galerkin approximation of (25) by a diagonal matrix whose i^{th} diagonal coefficient is obtained by summing up

all the coefficients of the i^{th} row of the mass matrix M), and where ϵ is a small (of the order of $h^2/\Delta t$) variable coefficient.

To summarize, if ξ_i is a strongly internal node,

$$\begin{aligned} u_i^{n+1} &= u_i^n + \frac{\Delta t}{\delta^2} (\mathcal{I}_h[u^n](\xi_i + \delta\Theta_i^n) + \mathcal{I}_h[u^n](\xi_i - \delta\Theta_i^n) - 2u_i^n), & \text{if } i \in \mathcal{J}_1^n, \\ u_i^{n+1} &= -A_{ii}^{-1} \sum_{j \neq i} A_{ij} u_j^n, & \text{if } i \in \mathcal{J}_2^n. \end{aligned} \quad (26)$$

For a given index $i = 1, \dots, N_h$, we write the nonlinear equation describing the scheme at node ξ_i (i.e. (13) if $\xi_i \in \Gamma_h^\ell$, (26) if ξ_i is a strongly internal node) in the generic form

$$\mathcal{G}^{\Delta t}(i, n, u^{n+1}, u^n) = 0, \quad i = 1, \dots, N_h. \quad (27)$$

Remark 5 *The scheme at strongly inner nodes can be interpreted in various ways: first, the method introduced in [17] is used as long as $|Du|$ is large enough: the stochastic dynamical system which is behind the degenerate parabolic operator is discretized and we obtain a system of “generalized characteristics” for the degenerate problem. The stochastic problem behind this interpretation has been introduced and analyzed by Buckdahn, Cardaliaguet and Quincampoix in [6] and Soner and Touzi in [28, 27]. More recently, Kohn and Serfaty have given in [21] a discrete game interpretation, in which the degenerate parabolic operator is approximated by a time discretization of min–max type.*

Second, in order to handle the singular case $|Du| = 0$, the scheme proposed in [17] is modified by switching to an approximation of the heat equation whenever $|Du|$ is below a given threshold.

Property Invariance with respect to the addition of constants

If we write the global scheme in the form

$$u^{n+1} = \mathcal{S}^{\Delta t}(u^n),$$

then it is easy to prove that, for all real number k , we have,

$$\mathcal{S}^{\Delta t}(u^n + k) = \mathcal{S}^{\Delta t}(u^n) + k.$$

Remark 6 *It is interesting to note that, if Assumption 1 does not hold, then one may wish to use a scheme different from (23): it is well known that there exists a field of symmetric tensors $x \rightarrow a(x)$ such that $a|_t$ is constant for all $t \in \mathcal{T}_h$, and that there exist three positive constants $\alpha \leq \underline{a} < \bar{a}$ independent of h such that for all $\xi \in \mathbb{R}^2$,*

- *a satisfies the uniform continuity and ellipticity properties:*

$$|a(x)\xi| \leq \bar{a}|\xi|, \quad \text{and} \quad \xi^T a(x)\xi \geq \underline{a}|\xi|^2;$$

- *the matrix $\tilde{A} \in \mathbb{R}^{N_h \times N_h}$: $\tilde{A}_{i,j} = \int_{\Omega_h} a(x) D\lambda_i(x) \cdot D\lambda_j(x) dx$ is a M-matrix. Moreover, if $\xi_i \neq \xi_j$ are two vertices of a same triangle $t \in \mathcal{T}_h$, then $\tilde{A}_{i,j} \leq -\frac{\alpha}{h^2}$.*

Then, instead of (23), one may use

$$u_i^{n+1} = -\frac{\sum_{j \neq i} \tilde{A}_{ij} u_j^n}{\tilde{A}_{ii}} = \frac{\sum_{j \neq i} \tilde{A}_{ij} u_j^n}{\sum_{j \neq i} \tilde{A}_{ij}}, \quad i \in \mathcal{J}_2^n.$$

2.4 An example of a Godunov like scheme for (11)

Let ξ_i belong to Ξ_h^ℓ . For simplicity, when writing the scheme, we drop the index accounting for time. To recover a scheme of the form (13), all the values of u related to boundary nodes should be taken at time t_{n+1} and all the values related to strongly internal nodes should be taken at time t_n .

If $\xi_i \notin \Gamma^\ell$, the line $\xi_i + \mathbb{R}n^\ell(\xi_i)$ cuts the polygonal line $\partial\omega_{\xi_i}$ at two points $\xi_i^{\nu,+}$ and $\xi_i^{\nu,-}$, with $(\xi_i^{\nu,+} - \xi_i) \cdot n^\ell(\xi_i) > 0$ and $(\xi_i^{\nu,-} - \xi_i) \cdot n^\ell(\xi_i) < 0$. We use the notation $h_i^{\nu,\pm} = |\xi_i^{\nu,\pm} - \xi_i|$. Similarly, if $t^\ell(\xi_i) = (-n_2^\ell(\xi_i), n_1^\ell(\xi_i))$, the line $\xi_i + \mathbb{R}t^\ell(\xi_i)$ cuts the polygonal line $\partial\omega_{\xi_i}$ at two points $\xi_i^{\tau,+}$ and $\xi_i^{\tau,-}$, with $(\xi_i^{\tau,+} - \xi_i) \cdot t^\ell(\xi_i) > 0$ and $(\xi_i^{\tau,-} - \xi_i) \cdot t^\ell(\xi_i) < 0$. We use the notation $h_i^{\tau,\pm} = |\xi_i^{\tau,\pm} - \xi_i|$. An example is given in Figure 2.

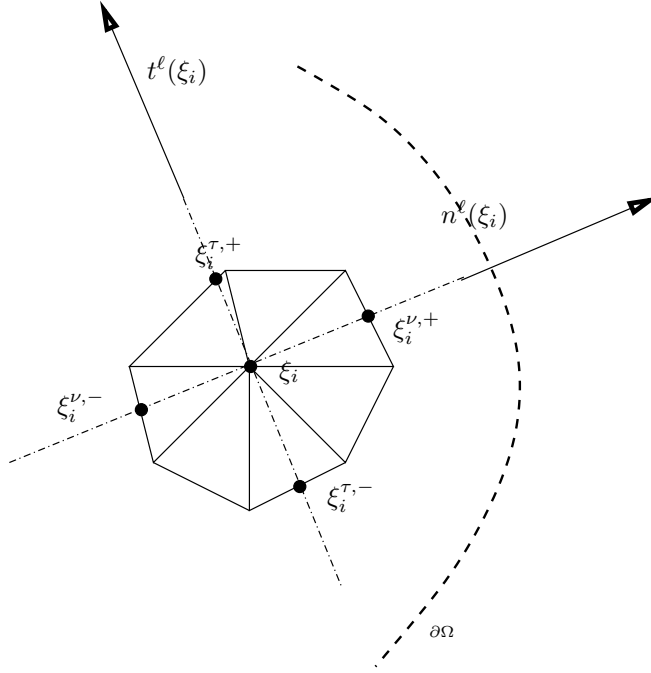

Figure 2: The construction of the scheme at $\xi_i \in \Xi_h^\ell \setminus \Gamma^\ell$

We use the following finite differences:

$$\begin{aligned} D_i^{\nu,+} u &= \frac{1}{h_i^{\nu,+}} \left(\mathcal{I}_h[u](\xi_i^{\nu,+}) - u_i \right), & D_i^{\nu,-} u &= \frac{1}{h_i^{\nu,-}} \left(u_i - \mathcal{I}_h[u](\xi_i^{\nu,-}) \right), \\ D_i^{\tau,+} u &= \frac{1}{h_i^{\tau,+}} \left(\mathcal{I}_h[u](\xi_i^{\tau,+}) - u_i \right), & D_i^{\tau,-} u &= \frac{1}{h_i^{\tau,-}} \left(u_i - \mathcal{I}_h[u](\xi_i^{\tau,-}) \right). \end{aligned}$$

If $\theta < 0$, then the Godunov scheme at ξ_i is:

$$D_i^{\nu,-} u - \theta \left(\min(D_i^{\nu,+} u, 0)^2 + \max(D_i^{\nu,-} u, 0)^2 + \min(D_i^{\tau,+} u, 0)^2 + \max(D_i^{\tau,-} u, 0)^2 \right)^{\frac{1}{2}} = 0.$$

If $\theta > 0$, then the Godunov scheme at ξ_i is:

$$D_i^{\nu,-} u - \theta \left(\max(D_i^{\nu,+} u, 0)^2 + \min(D_i^{\nu,-} u, 0)^2 + \max(D_i^{\tau,+} u, 0)^2 + \min(D_i^{\tau,-} u, 0)^2 \right)^{\frac{1}{2}} = 0.$$

If on the contrary, ξ_i lies on Γ_ℓ , then we define $\xi_i^{\nu,-}$ and $h_i^{\nu,-}$ as above, but the nodes $\xi_i^{\tau,\pm}$ are now the two neighbors of ξ_i on Γ_ℓ ; we take $h_i^{\tau,\pm} = |\xi_i^{\tau,\pm} - \xi_i|$. If $\theta < 0$, then the upwind scheme at ξ_i is:

$$D_i^{\nu,-} u - \theta \left(\min(D_i^{\tau,+} u, 0)^2 + \max(D_i^{\tau,-} u, 0)^2 + (D_i^{\nu,-} u)^2 \right)^{\frac{1}{2}} = 0.$$

If $\theta > 0$, then the Godunov scheme at ξ_i is:

$$D_i^{\nu,-} u - \theta \left(\max(D_i^{\tau,+} u, 0)^2 + \min(D_i^{\tau,-} u, 0)^2 + (D_i^{\nu,-} u)^2 \right)^{\frac{1}{2}} = 0.$$

3 Analysis of the scheme

Our goal is to establish the convergence of our approximation scheme (26)–(27) via the abstract result by Barles and Souganidis [5]. To this end we will first prove that the scheme is consistent and monotone.

Let us recall, for readers convenience, the definition of viscosity solution for the the boundary value problem. We denote by $\underline{F}(p, X)$ and $\overline{F}(p, X)$ the lower and upper semicontinuous extensions of the function $F(p, X) = -\text{trace}((I - \frac{p \otimes p}{|p|^2})X)$ at $p = 0$, given by

$$\underline{F}(p, X) = \begin{cases} F(p, X) & \text{if } p \neq 0, \\ -2|X| & \text{if } p = 0 \end{cases} \quad \overline{F}(p, X) = \begin{cases} F(p, X) & \text{if } p \neq 0, \\ 2|X| & \text{if } p = 0. \end{cases}$$

With the notation:

$$\begin{aligned} \overline{G}(x, \eta, p, X) &= \begin{cases} \eta + \overline{F}(p, X) & \text{if } x \in \Omega, \\ \max(\eta + \overline{F}(p, X), p \cdot n - \theta|p|) & \text{if } x \in \partial\Omega, \end{cases} \\ \underline{G}(x, \eta, p, X) &= \begin{cases} \eta + \underline{F}(p, X) & \text{if } x \in \Omega, \\ \min(\eta + \underline{F}(p, X), p \cdot n - \theta|p|) & \text{if } x \in \partial\Omega, \end{cases} \end{aligned} \quad (28)$$

and following [10], we say that an upper semicontinuous function u is a subsolution if for all $\Phi \in \mathcal{C}^1(\overline{\Omega} \times (0, T])$, if (x_0, t_0) is a maximum point of $u - \Phi$ then

$$\underline{G}(x_0, \frac{\partial \Phi}{\partial t}(x_0, t_0), D\Phi(x_0, t_0), D^2\Phi(x_0, t_0)) \leq 0; \quad (29)$$

we say that a lower semicontinuous function u is a supersolution if for all $\Phi \in \mathcal{C}^1(\overline{\Omega} \times (0, T])$, if (x_0, t_0) is a minimum point of $u - \Phi$ then

$$\overline{G}(x_0, \frac{\partial \Phi}{\partial t}(x_0, t_0), D\Phi(x_0, t_0), D^2\Phi(x_0, t_0)) \geq 0. \quad (30)$$

3.1 Consistency

Following Barles and Souganidis [5], we say that the scheme (27) is consistent if for any smooth function Φ defined on $[0, T] \times \overline{\Omega}$, we have that for any $t \in (0, T]$ and $x \in \overline{\Omega}$, for any sequence of positive mesh parameters $(h_m, \Delta t_m, \delta_m)$ tending to 0 with $h_m = o(\delta_m)$, for any sequence $\xi_{i,m}$ tending to x as $m \rightarrow \infty$, $\xi_{i,m}$ being a mesh node of \mathcal{T}_{h_m} , and for any sequence $t_{n_m} = n_m h_m$ tending to t as m tends to ∞ ,

$$\begin{aligned}
\underline{G}(x, \frac{\partial \Phi}{\partial t}(x, t), D\Phi(x, t), D^2\Phi(x, t)) &\leq \liminf_{m \rightarrow \infty} \mathcal{G}^{\Delta t}(i_m, n_m, \Phi^{n_m+1}, \Phi^{n_m}) \\
&\leq \limsup_{m \rightarrow \infty} \mathcal{G}^{\Delta t}(i_m, n_m, \Phi^{n_m+1}, \Phi^{n_m}) \\
&\leq \overline{G}(x, \frac{\partial \Phi}{\partial t}(x, t), D\Phi(x, t), D^2\Phi(x, t)),
\end{aligned} \tag{31}$$

calling $\Phi^n = (\Phi(\xi_j, n\Delta t))_{j=1, \dots, N_h}$.

Proposition 1 *Assume that $h^2/\Delta t = o(1)$, $h/\delta = o(1)$ and $h^{q-s}/\delta = o(1)$. Then the scheme is consistent.*

Proof. Consider a sequence of positive mesh parameters $(h_m, \Delta t_m, \delta_m)$ tending to 0 with $h_m = o(\delta_m)$, a sequence $\xi_{i,m}$ (tending to x as $m \rightarrow \infty$, $\xi_{i,m}$ being a mesh node of \mathcal{T}_{h_m} , and a sequence $t_{n_m} = n_m h_m$ tending to t as h tends to 0. For brevity, we will drop the index m when there is no ambiguity.

We can make out four cases:

Case 1: $x \in \Omega$ and $D\Phi(x, t) \neq 0$ In this case, we know that there exists $\rho > 0$ and $\kappa > 0$ such that the ball $B(x, \rho)$ is contained in Ω and that $|D\Phi(y, s)| > \kappa$ for all $y \in B(x, \rho)$ and $s \in [\min(0, t - \rho), \max(T, t + \rho)]$. Since $[D_h \Phi(\cdot, t)]$ is a consistent approximation of the gradient $D\Phi(\cdot, t)$, we know that if h and Δt are small enough, then for all the mesh nodes ξ contained in e.g. $B(x, \rho/2)$, and for all the discrete times $t_n \in [\min(0, t - \rho/2), \max(T, t + \rho/2)]$, we have $|[D_h \Phi(\cdot, t_n)](\xi)| > Ch^s$, where C and s are the constant used in (20). Moreover, we can choose δ small enough such that all the mesh nodes contained in $B(x, \rho/2)$ are internal mesh nodes. Therefore, for m large enough, for all the mesh nodes ξ_i contained in the ball $B(x, \rho/2)$ and for all the discrete times $t_n \in [\min(0, t - \rho/2), \max(T, t + \rho/2)]$,

$$\mathcal{G}^{\Delta t}(i, n, \Phi^{n+1}, \Phi^n) = \frac{\Phi(\xi_i, t_{n+1}) - \Phi(\xi_i, t_n)}{\Delta t} + \frac{2\Phi(\xi_i, t_n) - \mathcal{I}_h[\Phi^n](\xi_i + \delta\Theta_i^n) - \mathcal{I}_h[\Phi^n](\xi_i - \delta\Theta_i^n)}{\delta^2}, \tag{32}$$

where Θ_i^n is given by (21) with $D_i^n = [D_h \Phi^n](\xi_i)$.

Then, using the results contained in Carlini et al [7], we have

$$\lim_{m \rightarrow \infty} \mathcal{G}^{\Delta t}(i, n, \Phi^{n+1}, \Phi^n) = \left(\frac{\partial \Phi}{\partial t} - \text{trace} \left(\left(I - \frac{D\Phi \otimes D\Phi}{|D\Phi|^2} \right) D^2\Phi \right) \right) (x, t), \tag{33}$$

which yields (31). In fact, following [7], it can be seen that, if $D\Phi(x, t) \neq 0$, then for m large enough and $|\xi_i - x| \sim h$, $|t - t_n| \sim \Delta t$,

$$\begin{aligned}
&\left| \mathcal{G}^{\Delta t}(i, n, \Phi^{n+1}, \Phi^n) - \left(\frac{\partial \Phi}{\partial t} - \text{trace} \left(\left(I - \frac{D\Phi \otimes D\Phi}{|D\Phi|^2} \right) D^2\Phi \right) \right) (x, t) \right| \\
&= O\left(\frac{h^2}{\delta^2}\right) + O\left(\frac{h^q}{\delta}\right) + O(\Delta t) + O(\delta^2).
\end{aligned} \tag{34}$$

Case 2: $x \in \Omega$ and $D\Phi(x, t) = 0$ a) Let us first suppose that for all m large enough, $D_i^n = [D_h \Phi^n](\xi_i)$ is such that $|D_i^n| \geq Ch^s$. If $s < q$, then for h small enough, $D\Phi(\xi_i, t_n) \neq 0$,

because the discrete gradient is an approximation of order q of the gradient. In this case, we have (32), and following [7], this implies that

$$\begin{aligned} & \left| \mathcal{G}^{\Delta t}(i, n, \Phi^{n+1}, \Phi^n) - \left(\frac{\partial \Phi}{\partial t} - \text{trace} \left(\left(I - \frac{D\Phi \otimes D\Phi}{|D\Phi|^2} \right) D^2 \Phi \right) \right) (\xi_i, t_n) \right| \\ &= O\left(\frac{h^2}{\delta^2}\right) + O\left(\frac{h^{q-s}}{\delta}\right) + O(\Delta t) + O(\delta^2). \end{aligned} \quad (35)$$

But

$$\lambda_{\min}(D^2 \Phi(\xi_i, t_n)) \leq \text{trace} \left(\left(I - \frac{D\Phi \otimes D\Phi}{|D\Phi|^2} \right) D^2 \Phi \right) (\xi_i, t_n) \leq \lambda_{\max}(D^2 \Phi(\xi_i, t_n))$$

where $\lambda_{\min}(D^2 \Phi(\xi_i, t_n))$ (resp. $\lambda_{\max}(D^2 \Phi(\xi_i, t_n))$) is the smallest (resp. largest) eigenvalue of $D^2 \Phi(\xi_i, t_n)$, so

$$-2 |D^2 \Phi(\xi_i, t_n)| \leq \text{trace} \left(\left(I - \frac{D\Phi \otimes D\Phi}{|D\Phi|^2} \right) D^2 \Phi \right) (\xi_i, t_n) \leq 2 |D^2 \Phi(\xi_i, t_n)|.$$

It $h^{q-s} = o(\delta)$, this implies that

$$\begin{aligned} \frac{\partial \Phi}{\partial t}(x, t) + \underline{F}(0, D^2 \Phi(x, t)) &\leq \liminf_{m \rightarrow \infty} \mathcal{G}^{\Delta t}(i, n, \Phi^{n+1}, \Phi^n) \\ &\leq \limsup_{m \rightarrow \infty} \mathcal{G}^{\Delta t}(i, n, \Phi^{n+1}, \Phi^n) \\ &\leq \frac{\partial \Phi}{\partial t}(x, t) + \overline{F}(0, D^2 \Phi(x, t)). \end{aligned} \quad (36)$$

b) Let us now suppose that for all m large enough, $D_i^n = [D_h \Phi^n](\xi_i)$ is such that $|D_i^n| < Ch^s$. Thus,

$$\mathcal{G}^{\Delta t}(i, n, \Phi^{n+1}, \Phi^n) = \frac{1}{\Delta t} (\Phi_i^{n+1} - \Phi_i^n) + \epsilon_i \left(\sum_{j=1}^{N_h} M_{ij} \right)^{-1} \sum_{j=1}^{N_h} A_{ij} \Phi_j^n.$$

where

$$\epsilon_i = \frac{\left(\sum_{j=1}^{N_h} M_{ij} \right)}{\Delta t A_{ii}}.$$

It is simple to prove that if $h^2/\Delta t = o(1)$ then

$$\lim_{m \rightarrow \infty} \mathcal{G}^{\Delta t}(i, n, \Phi^{n+1}, \Phi^n) = \frac{\partial \Phi}{\partial t}(x, t), \quad (37)$$

which implies (36).

From points a) and b), we easily deduce (31) when $D\Phi(x, t) = 0$.

Case 3: $x \in \Gamma^\ell \subset \partial\Omega$ and $D\Phi(x, t) \neq 0$ In this case, we know that there exists $\rho > 0$ and $\kappa > 0$ such that $|D\Phi(y, s)| > \kappa$ for all $y \in B(x, \rho) \cap \overline{\Omega}$ and $s \in [\min(0, t - \rho), \max(T, t + \rho)]$.

a) Suppose that m large enough, ξ_i is a strictly internal mesh node: in this case, we can replicate

the arguments used in Case 1: for m large enough we may assume that $\xi_i \in B(\xi, h/2) \cap \Omega$ and obtain that

$$\lim_{m \rightarrow \infty} \mathcal{G}^{\Delta t}(i, n, \Phi^{n+1}, \Phi^n) = \left(\frac{\partial \Phi}{\partial t} - \text{trace} \left(\left(I - \frac{D\Phi \otimes D\Phi}{|D\Phi|^2} \right) D^2 \Phi \right) \right) (x, t). \quad (38)$$

b) Suppose that for m large enough, ξ_i belongs to Ξ_h^ℓ , so

$$\mathcal{G}^{\Delta t}(i, n, \Phi^{n+1}, \Phi^n) = \mathcal{B}^\ell(\xi_y, \Phi(\xi_i, t_{n+1}), [\Phi^{n+1}]_\ell, [[\Phi^n]]), \quad (39)$$

see (12) for the notations. Since this scheme is consistent with (11), we see that

$$\lim_{m \rightarrow \infty} \mathcal{G}^{\Delta t}(i, n, \Phi^{n+1}, \Phi^n) = \frac{\partial \Phi}{\partial n^\ell}(x, t) - \theta |D\Phi(x, t)|. \quad (40)$$

From the results obtained in points a) and b), it is an easy matter to deduce (31) by extracting subsequences if necessary.

Case 4: $x \in \Gamma^\ell \subset \partial\Omega$ and $D\Phi(x, t) = 0$ We argue as in Case 3, but we now have to consider three kinds of sequences (ξ_i, t_n) :

a) Suppose that for m large enough, ξ_i is a strictly internal mesh node, and $D_i^n = [D_h \Phi^n](\xi_i)$ is such that $|D_i^n| \geq Ch^s$. In this case, we argue as in Case 2:a).

b) Suppose that for m large enough, ξ_i is a strictly internal mesh node, and $D_i^n = [D_h \Phi^n](\xi_i)$ is such that $|D_i^n| < Ch^s$. In this case, we argue as in Case 2:b).

c) Suppose that for m large enough, ξ_i belongs to Ξ_h^ℓ . We argue as in Case 3:b).

From the points a), b) and c), we deduce (31). ■

3.2 Monotonicity

To prove the monotonicity of the scheme, we suppose that Assumption 1 holds and we restrict ourselves to taking for $[D_h u]$ the first order approximation of the gradient defined in (18), so $q = 1$. Hereafter, we suppose that

$$h^{1-s} = o(\delta). \quad (41)$$

The standard definition of monotonicity is also replaced by a *generalized monotonicity* assumption stated as follows.

Definition 3 *the scheme $S^{\Delta t}$ is said to be monotone (in the generalized sense) if it satisfies the following conditions: let $(h_m, \Delta t_m, \delta_m)$ and (ξ_{j_m}, t_{n_m}) be generic sequences satisfying*

$$(h_m, \Delta t_m, \delta_m) \rightarrow 0 \quad \text{and} \quad (\xi_{j_m}, t_{n_m}) \rightarrow (\xi, t). \quad (42)$$

Then, for any smooth function ϕ ,

$$\text{if } v_{j_m} \leq \phi_{j_m}^{n_m-1} \quad \text{then} \quad S^{\Delta t_m}(v; j_m) \leq \tilde{S}^{\Delta t_m}(\phi^{n_m-1}; j_m) + o(\Delta t_m) \quad (43)$$

$$\text{if } \phi_j^{n_m-1} \leq v_{j_m} \quad \text{then} \quad \tilde{S}^{\Delta t_m}(\phi^{n_m-1}; j_m) \leq S^{\Delta t_m}(v; j_m) + o(\Delta t_m), \quad (44)$$

where v is a set of node values, and $\tilde{S}^{\Delta t}$ is a (possibly different) scheme consistent in the sense that it satisfies (31) in (ξ, t) .

In the sequel, we write the scheme (13), (26) in the following compact form:

$$u_i^{n+1} = \mathcal{S}(u^n; i). \quad (45)$$

Following the ideas contained in [11], we will consider a scheme which results from the further introduction of a vanishing artificial viscosity in (45). The motivation for such an adaptation is the following. The scheme (22) is monotone only with respect to the nodes by the interpolation operator. On the other hand, the dependence on the values involved in the approximation of the gradient is more complex, and the introduction of the artificial viscosity term allows to gain monotonicity with respect to these values.

Therefore, we will prove the generalized monotonicity property for the modified scheme $u_i^{n+1} = \widehat{\mathcal{S}}(u^n; i)$: the scheme is not modified at boundary nodes, and if ξ_i is a strongly internal node, then

$$\begin{aligned} \widehat{\mathcal{S}}(u^n; i) &= \mathcal{S}(u^n; i) - W \frac{\Delta t}{\delta h^{s+1}} \sum_{j=1}^{N_h} A_{ij} u_j^n, & \text{if } i \in \mathcal{J}_1^n, \\ &= -(A_{ii})^{-1} \sum_{j \neq i} A_{ij} u_j^n, & \text{if } i \in \mathcal{J}_2^n, \end{aligned} \quad (46)$$

where W is a suitable positive constant. Finally, we do not need to consider boundary nodes, because the scheme (12) is monotone (in the classical sense). We thus focus on strongly internal nodes.

First inequality To check (43), suppose now that for any sequence $(\xi_j, t_n) \equiv (\xi_{j_m}, t_{n_m})$ verifying (42), the following inequality holds

$$u_j^n \leq \varphi_j^n \equiv \Phi(\xi_j, t_n) \quad (47)$$

where u^n is the solution of (13) and (26), for test functions $\Phi \in C^\infty(\bar{\Omega} \times [0, T])$. Since the monotonicity property does not depend on the iteration n , then, with no loss of generality, we can drop the dependency on t of the test function Φ . Condition (43) can be recast in the form

$$\widehat{\mathcal{S}}(u^n; i) \leq \widetilde{\mathcal{S}}(\varphi; i) + o(\Delta t), \quad (48)$$

where the choice of $\widetilde{\mathcal{S}}$ may vary from one subcase to the other. We will often omit the time index, writing u for u^n .

The proof discriminates between two main cases.

Case 1 $D\Phi(\xi) \neq 0$.

a) ξ_i is a strongly internal node and $|[D_h u](\xi_i)| \geq Ch^s$. Recall that we have denoted by Σ_i the sets of node indices involved in the construction in $[D_h u](\xi_i)$. It is clear that if $j \notin \Sigma_i$, then $\frac{\partial \mathcal{S}(u; i)}{\partial u_j} \geq 0$, from the monotonicity of the piecewise linear Lagrange interpolation operator \mathcal{I}_h .

On the other hand, if $j \in \Sigma_i$, $j \neq i$, then calling $z_i^\pm = \xi_i \pm \delta \Theta_i$, and assuming that z_i^\pm do not lie on the boundary of a triangle of \mathcal{T}_h ,

$$\frac{\partial \mathcal{S}(u; i)}{\partial u_j} = \frac{\Delta t}{\delta} (D(\mathcal{I}_h[u])(z_i^+) - D(\mathcal{I}_h[u])(z_i^-)) \frac{\partial \Theta_i}{\partial u_j}. \quad (49)$$

It can be proved that there exists a constant L independent of h such that if $|[D_h u](\xi_i)| \geq Ch^s$ and $j \in \Sigma_i$,

$$-L \frac{\Delta t}{\delta h^{s+1}} \leq \frac{\partial \mathcal{S}(u; i)}{\partial u_j} \leq L \frac{\Delta t}{\delta h^{s+1}}. \quad (50)$$

Therefore, differentiating $\widehat{S}(u; i)$, we get

$$\frac{\partial \widehat{S}(u; i)}{\partial u_j} \geq \frac{\Delta t}{\delta h^{s+1}}(-L - WA_{ij}) \geq \frac{\Delta t}{\delta h^{s+1}}(-L + W\alpha), \quad (51)$$

where α is the constant appearing in (10). Similarly, for a positive constant \bar{a} ,

$$\frac{\partial \widehat{S}(u; i)}{\partial u_i} \geq 1 + \frac{2\Delta t}{\delta^2} - \frac{\Delta t}{\delta h^{s+1}}(L + WA_{ii}) \geq 1 + \frac{2\Delta t}{\delta^2} - \frac{\Delta t}{\delta h^{s+1}}(L + W\bar{a}). \quad (52)$$

Therefore, if the conditions

$$\begin{aligned} -L + W\alpha &\geq 0, \\ 1 + \frac{2\Delta t}{\delta^2} - \frac{\Delta t}{\delta h^{s+1}}(L + W\bar{a}) &\geq 0 \end{aligned} \quad (53)$$

are fulfilled, then $\frac{\partial \widehat{S}(u; i)}{\partial u_j} \geq 0$, for all i such that $|[D_h u](\xi_i)| \geq Ch^s$ and for all j .

Then, we conclude as in [7].

b) $|[D_h u](\xi_i)| \leq Ch^s$. Since $\Phi \in C^\infty(\mathbb{R}^2)$, by a Taylor expansion we can write:

$$\Phi(\xi) = \Phi(\xi_i) + (\xi - \xi_i) \cdot D\Phi(\xi_i) + \frac{1}{2}(\xi - \xi_i) \cdot D^2\Phi(\xi_i)(\xi - \xi_i) + O(|\xi - \xi_i|^3).$$

Therefore

$$u_j \leq \Phi(\xi_i) + (\xi_j - \xi_i) \cdot D\Phi(\xi_i) + \frac{1}{2}(\xi_j - \xi_i) \cdot D^2\Phi(\xi_i)(\xi_j - \xi_i) + O(|\xi_j - \xi_i|^3).$$

On the other hand, we are going to use the special construction of $[D_h u](\xi_i)$ given in (18):

$$|\omega_{\xi_i}|[D_h u](\xi_i) = \begin{pmatrix} \sum_{j \neq i} u_j \int_{\omega_{\xi_i}} D\lambda_j \cdot e_1 \\ \sum_{j \neq i} u_j \int_{\omega_{\xi_i}} D\lambda_j \cdot e_2 \end{pmatrix}.$$

Therefore, $|[D_h u](\xi_i)| \leq Ch^s$ implies that for any constant vector ζ ,

$$\left| \sum_{j \neq i} u_j \int_{\omega_{\xi_i}} D\lambda_j \cdot \frac{\zeta}{h} \right| \leq Ch^{s+1}. \quad (54)$$

Hence,

$$\begin{aligned} -\sum_{j \neq i} A_{i,j} u_j &= -\int_{\omega_{\xi_i}} D\mathcal{I}_h[u] \cdot D\lambda_i + u_i D\lambda_i \cdot D\lambda_i \\ &= -\sum_{j \neq i} u_j \int_{\omega_{\xi_i}} D\lambda_j \cdot D\lambda_i \\ &\leq -\sum_{j \neq i} u_j \int_{\omega_{\xi_i}} D\lambda_j \cdot (D\lambda_i - \frac{\zeta}{h}) + Ch^{s+1}. \end{aligned} \quad (55)$$

Under the assumptions on the mesh, it is always possible to choose ζ small enough such that

$$C > -\int_{\omega_{\xi_i}} D\lambda_j \cdot (D\lambda_i - \frac{\zeta}{h}) > c > 0, \quad \text{for all } i, j \in \Sigma_i, j \neq i. \quad (56)$$

With such a choice, exploiting the relations between the matrix involved in the artificial viscosity term and the linear interpolation operator of the gradient, we get

$$\begin{aligned} -\sum_{j \neq i} A_{i,j} u_j &\leq -\sum_{j \neq i} \Phi(\xi_j) \int_{\omega_{\xi_i}} D\lambda_j \cdot (D\lambda_i - \frac{\zeta}{h}) + Ch^{s+1} \\ &= -\sum_{j \neq i} K_j \int_{\omega_{\xi_i}} D\lambda_j \cdot (D\lambda_i - \frac{\zeta}{h}) + Ch^{s+1}, \end{aligned} \quad (57)$$

where

$$K_j = \Phi(\xi_i) + (\xi_j - \xi_i) \cdot D\Phi(\xi_i) + \frac{1}{2}(\xi_j - \xi_i) \cdot D^2\Phi(\xi_i)(\xi_j - \xi_i) + O(|\xi_j - \xi_i|^3).$$

From (57), we deduce that

$$\begin{aligned} -\sum_{j \neq i} A_{i,j} u_j &\leq -\left(\sum_{j \neq i} A_{i,j}\right) \Phi(\xi_i) + \sum_{j \neq i} (\xi_j - \xi_i) \cdot D\Phi(\xi_i) \int_{\omega_{\xi_i}} D\lambda_j \cdot \frac{\zeta}{h} \\ &\quad -\frac{1}{2} \sum_{j \neq i} (\xi_j - \xi_i) \cdot D^2\Phi(\xi_i)(\xi_j - \xi_i) \int_{\omega_{\xi_i}} D\lambda_j \cdot (D\lambda_i - \frac{\zeta}{h}) + O(h^{s+1}) \end{aligned} \quad (58)$$

because

$$-\Phi(\xi_i) \sum_{j \neq i} \int_{\omega_{\xi_i}} D\lambda_j \cdot \frac{\zeta}{h} = \Phi(\xi_i) \int_{\omega_{\xi_i}} D\lambda_i \cdot \frac{\zeta}{h} = 0,$$

and

$$-\sum_{j \neq i} (\xi_j - \xi_i) \cdot D\Phi(\xi_i) \int_{\omega_{\xi_i}} D\lambda_j \cdot D\lambda_i = D\Phi(\xi_i) \cdot \int_{\omega_{\xi_i}} D\lambda_i = 0.$$

Note also that

$$\sum_{j \neq i} (\xi_j - \xi_i) \int_{\omega_{\xi_i}} D\lambda_j \cdot \frac{\zeta}{h} = |\omega_{\xi_i}| \frac{\zeta}{h}.$$

Hence, choosing now $\zeta = -\mu \frac{D\Phi(\xi_i)}{|D\Phi(\xi_i)|}$ with μ small enough such that (56) holds true yields

$$\begin{aligned} -\sum_{j \neq i} A_{i,j} u_j^n &\leq -\left(\sum_{j \neq i} A_{i,j}\right) \Phi(\xi_i) - \mu |D\Phi(\xi_i)| \frac{|\omega_{\xi_i}|}{h} \\ &\quad -\frac{1}{2} \sum_{j \neq i} (\xi_j - \xi_i) \cdot D^2\Phi(\xi_i)(\xi_j - \xi_i) \int_{\omega_{\xi_i}} D\lambda_j \cdot (D\lambda_i - \frac{\zeta}{h}) + O(h^{s+1}). \end{aligned} \quad (59)$$

Next, using the fact that u^n satisfies (23), we add and subtract $\Delta t F(D\Phi(\xi), D^2\Phi(\xi))$ (note that $\underline{F} = \overline{F} = F$, since we are in the case $D\Phi(\xi) \neq 0$), obtaining

$$\begin{aligned} u_j^{n+1} &\leq \Phi(\xi_i) - \Delta t F(D\Phi(\xi), D^2\Phi(\xi)) \\ &\quad - \frac{1}{\sum_{j \neq i} A_{i,j}} \left(\begin{aligned} &-\mu |D\Phi(\xi_i)| \frac{|\omega_{\xi_i}|}{h} - \frac{1}{2} \sum_{j \neq i} (\xi_j - \xi_i) \cdot D^2\Phi(\xi_i)(\xi_j - \xi_i) \int_{\omega_{\xi_i}} D\lambda_j \cdot (D\lambda_i - \frac{\zeta}{h}) \\ &-\Delta t \sum_{j \neq i} A_{i,j} F(D\Phi(\xi), D^2\Phi(\xi)) + O(h^{s+1}) \end{aligned} \right). \end{aligned} \quad (60)$$

Since $\Phi \in C^\infty$ and since from (53), $\Delta t = o(h)$, we have that asymptotically for $h \rightarrow 0$ and $\Delta t \rightarrow 0$,

$$0 \geq -\mu |D\Phi(\xi_i)| \frac{|\omega_{\xi_i}|}{h} - \frac{1}{2} \sum_{j \neq i} (\xi_j - \xi_i) \cdot D^2\Phi(\xi_i) (\xi_j - \xi_i) \int_{\omega_{\xi_i}} D\lambda_j \cdot (D\lambda_i - \frac{\zeta}{h}) - \Delta t \sum_{j \neq i} A_{i,j} F(D\Phi(\xi), D^2\Phi(\xi)) + O(h^{s+1}), \quad (61)$$

hence there exists a $\overline{\Delta t} > 0$ such that for every $\Delta t < \overline{\Delta t}$:

$$u_i^{n+1} \leq \Phi(\xi_i) - \Delta t F(D\Phi(\xi), D^2\Phi(\xi)). \quad (62)$$

The scheme denoted by \tilde{S} in (48) may now be chosen as a generic scheme satisfying (31) at ξ . Since the test function Φ does not depend on time, $\tilde{S}(\varphi; i)$ verifies:

$$\lim_{m \rightarrow \infty} \frac{\varphi(\xi_{i_m}) - \tilde{S}(\varphi; i_m)}{\Delta t_m} = F(D\Phi(\xi), D^2\Phi(\xi)),$$

so that we have $\Phi(\xi_i) - \tilde{S}(\varphi; i) = \Delta t F(D\Phi(\xi), D^2\Phi(\xi)) + o(\Delta t)$ and we finally get

$$u_i^{n+1} \leq \tilde{S}(\varphi; i) + o(\Delta t).$$

Case 2 $D\Phi(\xi) = 0$.

When $|[D_h u](\xi_i)| \leq Ch^s$ the scheme is clearly monotone (in the conventional sense) at the node ξ_i , being a convex combination of node values.

For $|[D_h u](\xi_i)| \geq Ch^s$, the scheme still satisfies (43) since

$$u_i^{n+1} = \widehat{S}(u^n; i) \leq \tilde{S}(\varphi; i) \quad (63)$$

where $\tilde{S}(\varphi; i)$ has been chosen in the following form

$$\tilde{S}(\varphi; i) = \Phi(\xi_i) + \frac{\Delta t}{\delta^2} \left(\frac{1}{2} \mathcal{I}_h[\varphi](\xi_i + \delta \Theta_i^n) + \frac{1}{2} \mathcal{I}_h[\varphi](\xi_i - \delta \Theta_i^n) - \Phi(\xi_i) \right) - \frac{W \Delta t}{\delta h^{s+1}} \sum_j A_{i,j} \Phi(\xi_j),$$

where Θ_i^n is given by (21), i.e. is computed from the values of u^n . The inequality (63) holds because the upwind points $\xi_i \pm \delta \Theta_i^n$ are the same on the left and right term and the time step Δt verifies the second inequality in (53).

Moreover \tilde{S} is a consistent scheme, since under condition (41),

$$\frac{\Phi(\xi_i) - \tilde{S}(\varphi; i)}{\Delta t} = (\Theta_i^n)^T D^2\Phi(\xi_i) \Theta_i^n + o(1).$$

Therefore, following the same arguments used in *Case 2a* of the consistency proof,

$$\begin{aligned} \underline{F}(D\Phi(\xi), D^2\Phi(\xi)) &\leq \liminf_{m \rightarrow \infty} \frac{\Phi(\xi_{i_m}) - \tilde{S}(\varphi; i_m)}{\Delta t_m} \leq \\ &\leq \limsup_{m \rightarrow \infty} \frac{\Phi(\xi_{i_m}) - \tilde{S}(\varphi; i_m)}{\Delta t_m} \leq \overline{F}(D\Phi(\xi), D^2\Phi(\xi)), \end{aligned}$$

which yields the consistency for \tilde{S} at ξ .

Second inequality We have to check assumption (44). We now assume that, for $\Delta t \rightarrow 0$ and $(\xi_i, t_n) \rightarrow (x, t)$:

$$u_i^n \geq \Phi(\xi_i). \quad (64)$$

We need to prove that

$$\widehat{S}(u^n; i) \geq \widetilde{S}(\varphi; i) + o(\Delta t) \quad (65)$$

in which the choice of \widetilde{S} will follow the same guidelines used in proving (43).

Case 1 : $D\Phi(\xi) \neq 0$.

As we have seen, for $h \rightarrow 0$, the condition $|D_j[\varphi]| > Ch^s$ is asymptotically satisfied.

We consider the same subcases as before:

a) ξ_i is a strongly internal node and $|[D_h u](\xi_i)| \geq Ch^s$. The result is obtained exactly as the first inequality in Case 1 a).

b) ξ_i is a strongly internal node and $|[D_h u](\xi_i)| \leq Ch^s$. In this case, we use the same argument as for the first inequality in Case 1 b). Indeed, for any constant vector ζ ,

$$\begin{aligned} -\sum_{j \neq i} A_{i,j} u_j &= -\int_{\omega_{\xi_i}} D\mathcal{I}_h[u] \cdot D\lambda_i + u_i D\lambda_i \cdot D\lambda_i \\ &= -\sum_{j \neq i} u_j \int_{\omega_{\xi_i}} D\lambda_j \cdot D\lambda_i \\ &\geq -\sum_{j \neq i} u_j \int_{\omega_{\xi_i}} D\lambda_j \cdot (D\lambda_i - \frac{\zeta}{h}) - Ch^{s+1}, \end{aligned} \quad (66)$$

and it is always possible to choose ζ small enough such that (56) holds true. With such a choice,

$$\begin{aligned} -\sum_{j \neq i} A_{i,j} u_j &\geq -\left(\sum_{j \neq i} A_{i,j}\right) \Phi(\xi_i) + \sum_{j \neq i} (\xi_j - \xi_i) \cdot D\Phi(\xi_i) \int_{\omega_{\xi_i}} D\lambda_j \cdot \frac{\zeta}{h} \\ &\quad - \frac{1}{2} \sum_{j \neq i} (\xi_j - \xi_i) \cdot D^2\Phi(\xi_i) (\xi_j - \xi_i) \int_{\omega_{\xi_i}} D\lambda_j \cdot (D\lambda_i - \frac{\zeta}{h}) + O(h^{s+1}). \end{aligned} \quad (67)$$

Hence, choosing now $\zeta = -\mu \frac{D\Phi(\xi_i)}{|D\Phi(\xi_i)|}$ with μ small enough such that (56) holds true one gets

$$\begin{aligned} -\sum_{j \neq i} A_{i,j} u_j^n &\geq -\left(\sum_{j \neq i} A_{i,j}\right) \Phi(\xi_i) + \mu |D\Phi(\xi_i)| \frac{|\omega_{\xi_i}|}{h} \\ &\quad - \frac{1}{2} \sum_{j \neq i} (\xi_j - \xi_i) \cdot D^2\Phi(\xi_i) (\xi_j - \xi_i) \int_{\omega_{\xi_i}} D\lambda_j \cdot (D\lambda_i - \frac{\zeta}{h}) + O(h^{s+1}). \end{aligned} \quad (68)$$

Since u^n satisfies (23), we add and subtract $\Delta t F(D\Phi(\xi), D^2\Phi(\xi))$ (note that $\underline{F} = \overline{F} = F$, since we are in the case $D\Phi(\xi) \neq 0$), obtaining

$$\begin{aligned} u_j^{n+1} &\geq \Phi(\xi_i) - \Delta t F(D\Phi(\xi), D^2\Phi(\xi)) \\ &\quad - \frac{1}{\sum_{j \neq i} A_{i,j}} \left(\begin{aligned} &\mu |D\Phi(\xi_i)| \frac{|\omega_{\xi_i}|}{h} - \frac{1}{2} \sum_{j \neq i} (\xi_j - \xi_i) \cdot D^2\Phi(\xi_i) (\xi_j - \xi_i) \int_{\omega_{\xi_i}} D\lambda_j \cdot (D\lambda_i - \frac{\zeta}{h}) \\ &-\Delta t \sum_{j \neq i} A_{i,j} F(D\Phi(\xi), D^2\Phi(\xi)) + O(h^{s+1}) \end{aligned} \right), \end{aligned} \quad (69)$$

and as for the first inequality, there exists a $\overline{\Delta t} > 0$ such that for every $\Delta t < \overline{\Delta t}$:

$$u_i^{n+1} \geq \Phi(\xi_i) - \Delta t F(D\Phi(\xi), D^2\Phi(\xi)). \quad (70)$$

We add and subtract a generic scheme \tilde{S} satisfying (31) and get

$$u_i^{n+1} \geq \tilde{S}(\varphi; i) + o(\Delta t).$$

Case 2 : $D\Phi(\xi) = 0$. If ξ_i is a strongly internal node and $|[D_h u](\xi_i)| \leq Ch^s$, then we use the monotonicity of the scheme (23). Else, if ξ_i is a strongly internal node and $|[D_h u](\xi_i)| > Ch^s$, we have

$$u_i^{n+1} = \hat{S}(u^n; i) \geq \tilde{S}(\varphi; i), \quad (71)$$

where \tilde{S} is the scheme chosen in the discussion of the first inequality, Case 2.

In conclusion, we have proved the following:

Theorem 1 *Let us suppose that Assumption 1 holds and that $[D_h u]$ is the first order approximation of the gradient defined in (18). Under the same assumptions of Proposition 1 (with $q = 1$), and under conditions (41) and (53), the regularized scheme (46) is monotone in the sense given by Definition 3.*

Corollary 1 *Under the assumption of Theorem 1, the regularized scheme (46) is convergent.*

Proof. The monotonicity of the regularized scheme comes from Theorem 1. For the consistency, the same proof as that of Proposition 1 can be used. ■

Remark 7 *The analysis above has been made only in dimension two, for meshes with acute angles, in the case when A is given by (9) and the interpolation operator is given by (17). In this case A and the interpolation operator are closely related to each other and the proof takes advantage of this relationship. It would be very interesting to generalize the proof to cases when the two operators are more independent from each other, in particular for the scheme proposed in Remark 6, and also to dimension three.*

4 Numerical results

Let us examine some numerical tests in dimension two in order to verify the efficiency and accuracy of our approximation scheme.

4.1 An example proposed by G. Barles

Take for Ω a ring with inner radius r and outer radius $R > r$, and set $u_0(x) = \phi(|x|^2)$. G. Barles has proved in [3] that the viscosity solution of (1),(4), (5) is

$$u(x, t) = \phi(\min(|x|^2 + 2t, R^2)), \text{ in } \overline{\Omega} \times (0, +\infty),$$

for any value of $\theta \in (-1, 1)$. The level set $u(x, t) = \phi(R^2)$ is the ring $x \in [\max(\sqrt{R^2 - 2t}, r), R]$. The partial differential equation holds up to the boundary $|x| = r$, and the boundary condition is lost there.

4.1.1 Results on a fully structured grid

Here, the domain is a ring with inner radius $r = 0.1$ and outer radius $R = 0.4$, and we have chosen $u_0(x) = 16|x|^2$, so $u(x, t) = \min(16(|x|^2 + 2t), 2.56)$. For a large integer N , the grid nodes are

$$\xi_{i,j} = (r + i(R - r)/N) \left(\cos(2j\pi/N), \sin(2j\pi/N) \right), \quad i = 0, \dots, N, j = 1, \dots, N,$$

and we take $\Delta t = (R - r)/(10N)$ and $\delta = \sqrt{2\Delta t} + 2(R - r)/N$.

We have chosen $\theta = 0.5$

On such a structured grid, the approximation of the gradient is a centered finite difference method in polar coordinates, so it is second order. Since the approximation of the gradient is second order, we choose $s = 1$. In this case, it is convenient to replace (23) with an explicit Euler scheme for the equation

$$\frac{\partial w}{\partial t} - \epsilon \left(\frac{\partial^2 w}{\partial r^2} + \frac{\partial^2 w}{\partial \theta^2} \right) = 0$$

with $\epsilon \sim \frac{1}{N^2 \Delta t}$.

Table 1: $\|\text{Error}\|_\infty$

N	50	100	200	400
Error	0.116	0.082	0.055	0.041
Rel. Error	4.53%	3.2%	2.14%	1.6%

In this case, as seen in Table 1, the error seems to decay like $N^{-\frac{1}{2}}$, which agrees with the estimates on the consistency error in (35).

4.1.2 Results on a nonstructured grid

The domain is a ring with inner radius $r = 1$ and outer radius $R = 2$. We take $u^0(x) = |x|^2$, so the viscosity solution of (1), (4), (5) is $u(x, t) = \min(|x|^2 + 2t, 4)$, for all θ .

For a given parameter h , we choose

$$\Delta t = h/10, \quad \delta = \sqrt{2\Delta t} + 2h, \quad s = 0.5.$$

We have chosen $\theta = -0.5$. Table 2 contains the errors in maximum norm with respect to the explicit solution for different values of h . It can be seen that the error decays to zero like \sqrt{h} . The contour lines of the solution at different times are shown in Figure 3, along with the two circles representing the boundaries of the layers ω^1 and ω^2 . We see that the scheme captures correctly the zones where the solution is constant. The error in maximum norm with respect to the explicit solution as a function of time is plotted in Figure 4.

Table 2: $\|\text{Error}\|_\infty$

h	0.04	0.02	0.01	0.0064
Error	0.21	0.154	0.114	0.095
Rel. Error	5.3%	3.8%	2.85%	2.37%

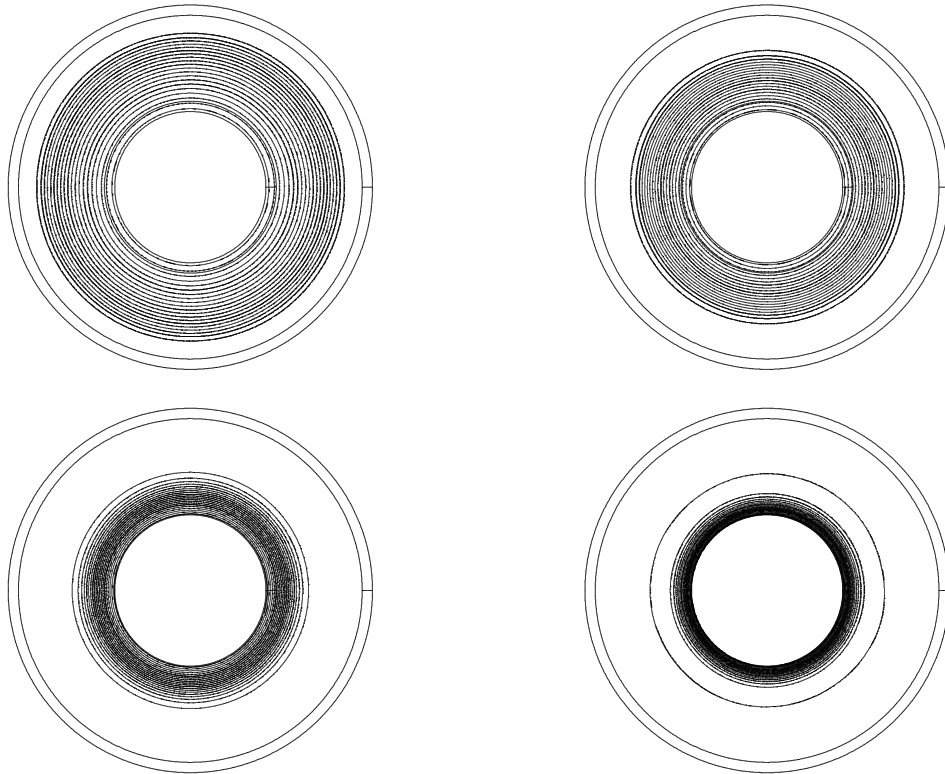

Figure 3: $h = 0.01$: contour lines at $t = 0.4, 0.8, 1.2, 1.6$. The boundary zones are also presented in the figures.

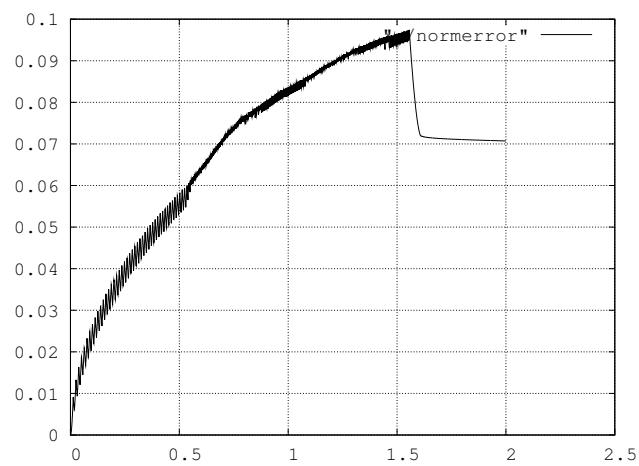

Figure 4: $h = 0.0064$: error in max norm vs. time

4.2 Other examples

4.2.1 Test 2

Here, the domain is a ring with inner radius $r = 1$ and outer radius $R = 2$, and we take $u_0(x) = \sin(\frac{16}{25}((x - 0.5)^2 + x_2^2))$. We use an unstructured mesh such that $h \sim 0.02$ and take $\Delta t = 0.002$. The thickness of the layers near the boundaries is of the order of 0.2.

The contour lines at different times, for $\theta = -0.5$, (resp. $\theta = 0.95$) are displayed in Figure 5 (resp. 6). In the first (resp. second) case the contour lines make an angle of 30° (resp $\sim 71.8^\circ$) with the normal to the boundary.

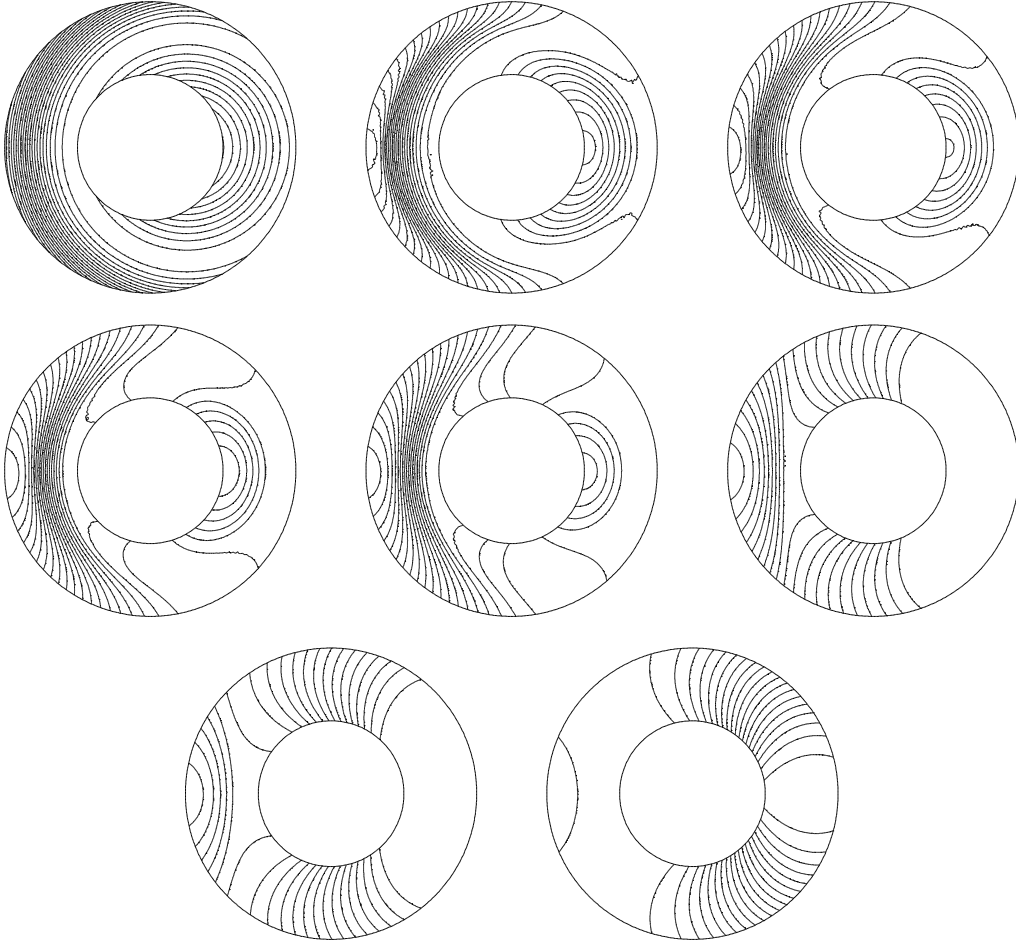

Figure 5: Test 2: $\theta = -0.5$, contour lines at $t = 0, 0.08, 0.16, 0.24, 0.32, 0.8, 1.2, 2$

4.2.2 Test 3

The domain is constructed as follows. It has a hole. The outer boundary is parametrized by

$$x_1 = 2 \cos(2\pi t) + 0.75 \cos(4\pi t), \quad x_2 = 2 \sin(2\pi t) + 0.75 \sin(4\pi t),$$

and the inner boundary is the unit circle of equation $|x - (0.5, 0)| = 1$. We choose $\theta = -0.5$ and $u^0(x) = |x_1|/10$. We take

$$h = 0.02, \quad \delta = 0.1, \quad \Delta t = 0.001.$$

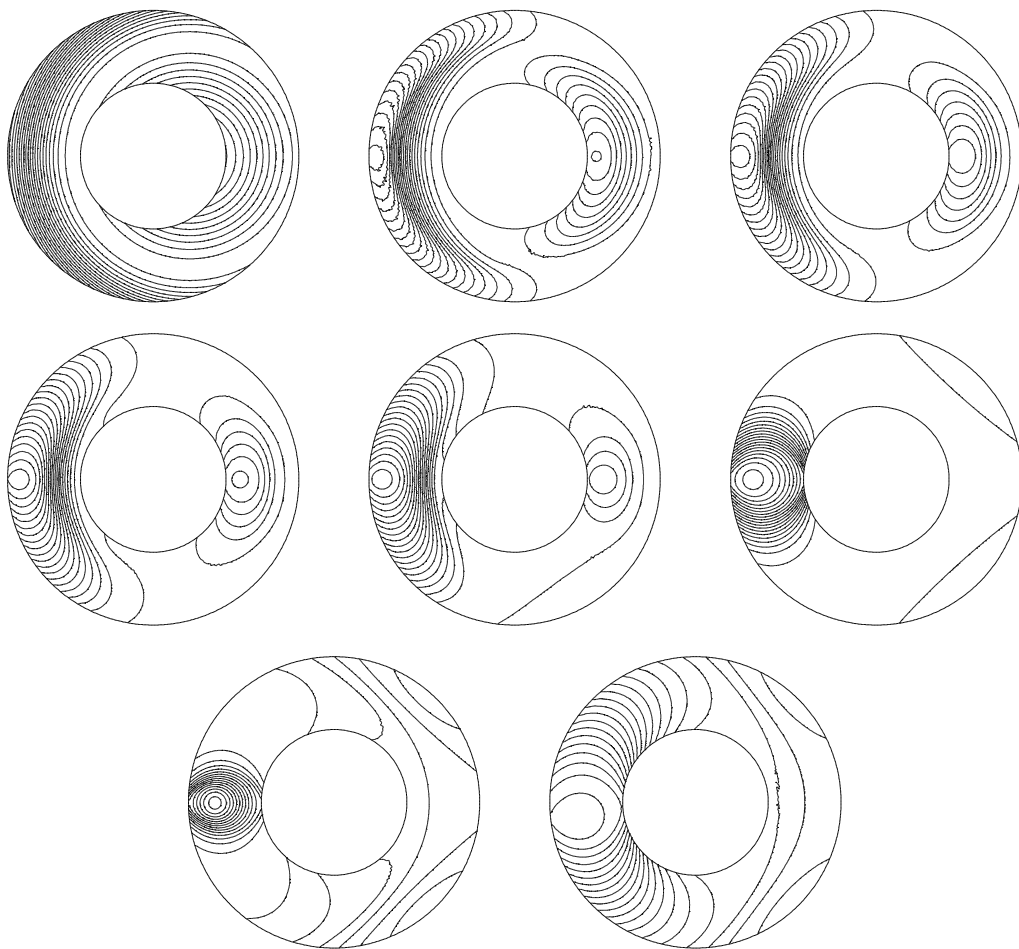

Figure 6: Test 2: $\theta = 0.95$, contour lines at $t = 0, 0.08, 0.16, 0.24, 0.32, 0.8, 1.2, 2$

Contour lines are displayed in Figure 7. We see that a level set with non empty interior appears.

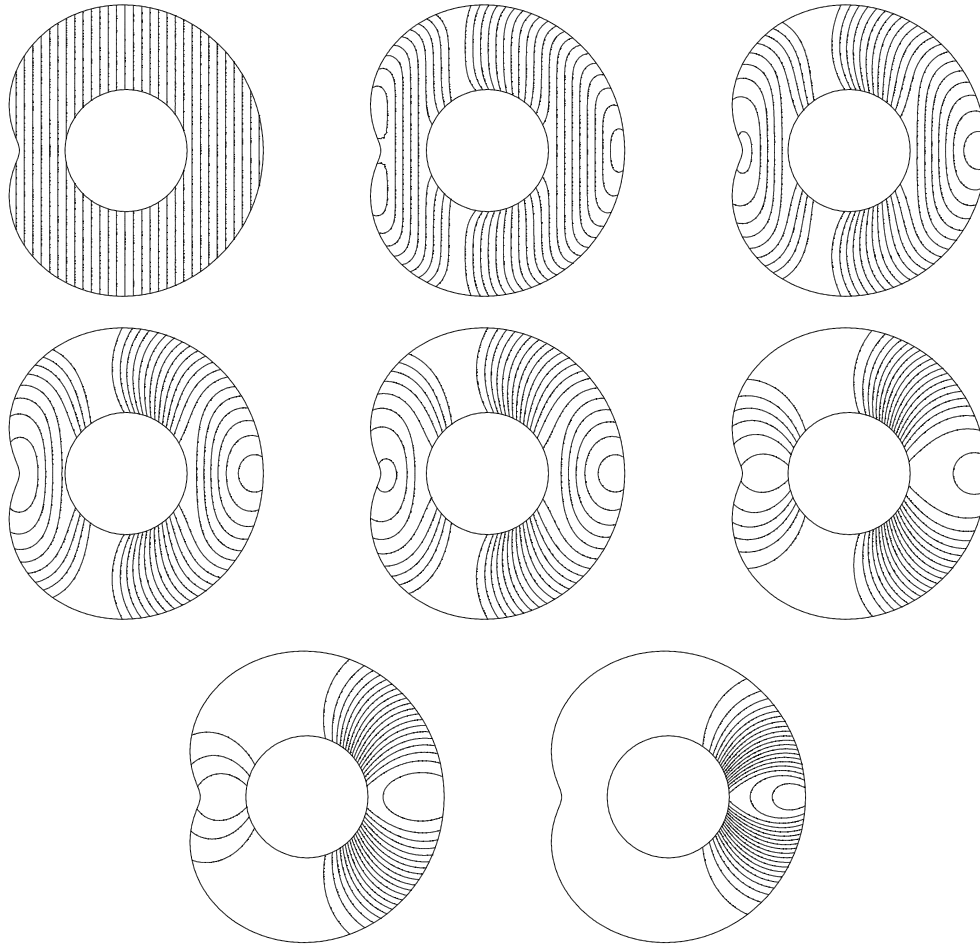

Figure 7: Test 3: contour lines at $t = 0, 0.08, 0.16, 0.24, 0.32, 0.8, 1.2, 2$

4.2.3 Test 4

The domain is constructed as follows. It has a hole. The outer boundary is parametrized by

$$x_1 = 2 \cos(2\pi t) + 0.75 \cos(4\pi t), \quad x_2 = 2 \sin(2\pi t) + 0.75 \sin(4\pi t),$$

and the inner boundary is the unit circle centered at 0. We choose $\theta = -0.5$ and $u^0(x) = \sin(4|x|)$. We take an unstructured mesh with

$$h = 0.02, \quad \delta = 0.1, \quad \Delta t = 0.001.$$

Contour lines are displayed in Figure 8.

References

- [1] R. Abgrall. Numerical discretization of the first-order Hamilton-Jacobi equation on triangular meshes. *Comm. Pure Appl. Math.*, 49(12):1339–1373, 1996.

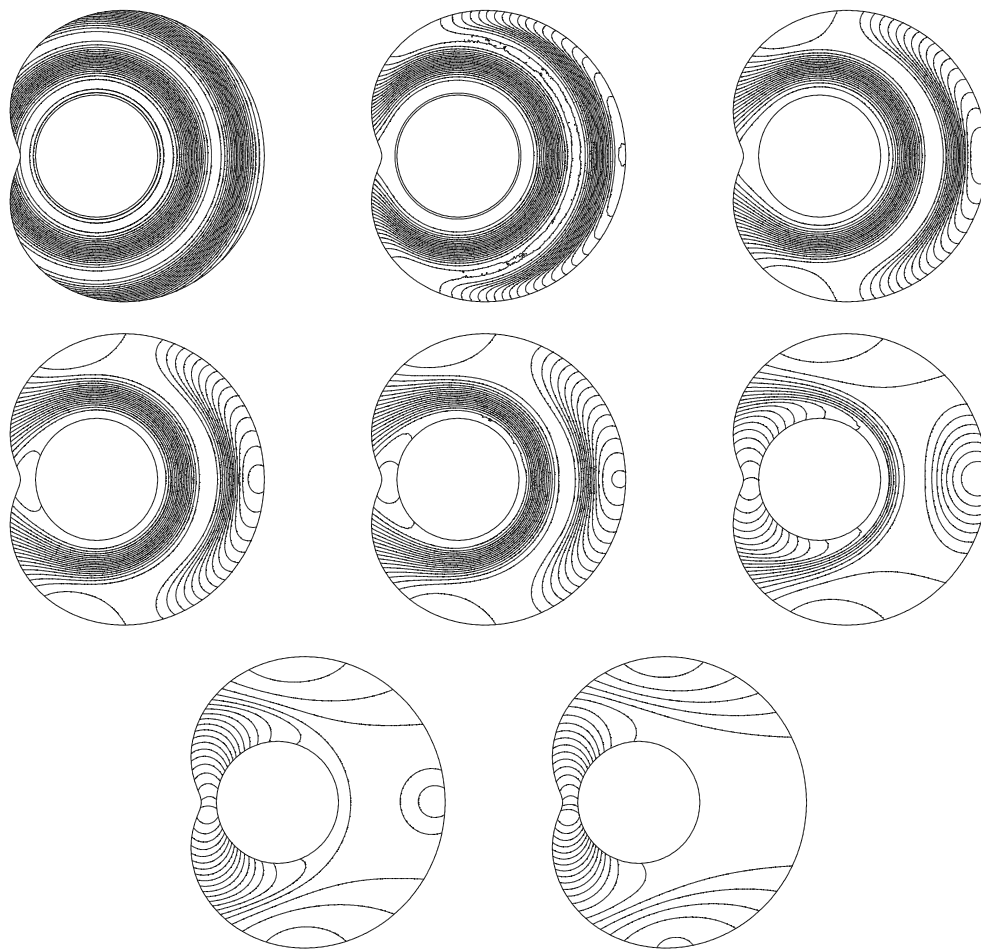

Figure 8: Test 4: contour lines at $t = 0, 0.08, 0.16, 0.24, 0.32, 0.8, 1.2, 2$

- [2] G. Barles. *Solutions de viscosité des équations de Hamilton-Jacobi*, volume 17 of *Mathématiques & Applications (Berlin) [Mathematics & Applications]*. Springer-Verlag, Paris, 1994.
- [3] G. Barles. Nonlinear Neumann boundary conditions for quasilinear degenerate elliptic equations and applications. *J. Differential Equations*, 154(1):191–224, 1999.
- [4] G. Barles and Ch. Georgelin. A simple proof of convergence for an approximation scheme for computing motions by mean curvature. *SIAM J. Numer. Anal.*, 32(2):484–500, 1995.
- [5] G. Barles and P. E. Souganidis. Convergence of approximation schemes for fully nonlinear second order equations. *Asymptotic Anal.*, 4(3):271–283, 1991.
- [6] R. Buckdahn, P. Cardaliaguet, and M. Quincampoix. A representation formula for the mean curvature motion. *SIAM J. Math. Anal.*, 33(4):827–846 (electronic), 2001.
- [7] E. Carlini, M. Falcone, and R. Ferretti. Convergence of a large time-step scheme for mean curvature motion. Technical report, Dipartimento di Matematica, SAPIENZA - Università di Roma, 2009, to appear in *Interfaces and Free Boundaries*.
- [8] Y. G. Chen, Y. Giga, and S. Goto. Uniqueness and existence of viscosity solutions of generalized mean curvature flow equations. *J. Differential Geom.*, 33(3):749–786, 1991.
- [9] B. Cockburn and J. Qian. Continuous dependence results for Hamilton-Jacobi equations. In *Collected lectures on the preservation of stability under discretization (Fort Collins, CO, 2001)*, pages 67–90. SIAM, Philadelphia, PA, 2002.
- [10] M. G. Crandall, H. Ishii, and P.-L. Lions. User’s guide to viscosity solutions of second order partial differential equations. *Bull. Amer. Math. Soc. (N.S.)*, 27(1):1–67, 1992.
- [11] M. G. Crandall and P.-L. Lions. Two approximations of solutions of Hamilton-Jacobi equations. *Math. Comp.*, 43(167):1–19, 1984.
- [12] M. G. Crandall and P.-L. Lions. Convergent difference schemes for nonlinear parabolic equations and mean curvature motion. *Numer. Math.*, 75(1):17–41, 1996.
- [13] K. Deckelnick and G. Dziuk. A fully discrete numerical scheme for weighted mean curvature flow. *Numer. Math.*, 91(3):423–452, 2002.
- [14] L. C. Evans. Convergence of an algorithm for mean curvature motion. *Indiana Univ. Math. J.*, 42(2):533–557, 1993.
- [15] L. C. Evans and J. Spruck. Motion of level sets by mean curvature. I. *J. Differential Geom.*, 33(3):635–681, 1991.
- [16] M. Falcone and R. Ferretti. Semi-Lagrangian schemes for Hamilton-Jacobi equations, discrete representation formulae and Godunov methods. *J. Comput. Phys.*, 175(2):559–575, 2002.
- [17] M. Falcone and R. Ferretti. Consistency of a large time-step scheme for mean curvature motion. In *Numerical mathematics and advanced applications*, pages 495–502. Springer Italia, Milan, 2003.

- [18] Y. Giga. *Surface evolution equations*, volume 99 of *Monographs in Mathematics*. Birkhäuser Verlag, Basel, 2006. A level set approach.
- [19] Y. Giga, M. Ohnuma, and M.-H. Sato. On the strong maximum principle and the large time behavior of generalized mean curvature flow with the Neumann boundary condition. *J. Differential Equations*, 154(1):107–131, 1999.
- [20] H. Ishii and K. Ishii. An approximation scheme for motion by mean curvature with right-angle boundary condition. *SIAM J. Math. Anal.*, 33(2):369–389 (electronic), 2001.
- [21] R. V. Kohn and S. Serfaty. A deterministic-control-based approach to motion by curvature. *Comm. Pure Appl. Math.*, 59(3):344–407, 2006.
- [22] R. H. Nochetto and C. Verdi. Convergence past singularities for a fully discrete approximation of curvature-driven interfaces. *SIAM J. Numer. Anal.*, 34(2):490–512, 1997.
- [23] S. Osher and R. Fedkiw. *Level set methods and dynamic implicit surfaces*, volume 153 of *Applied Mathematical Sciences*. Springer-Verlag, New York, 2003.
- [24] S. Osher and J. A. Sethian. Fronts propagating with curvature-dependent speed: algorithms based on Hamilton–Jacobi formulations. *J. Comput. Phys.*, 79(1):12–49, 1988.
- [25] M. Sagona and A. Seghini. An adaptive scheme on unstructured grids for the shape-from-shading problem. In *Numerical methods for viscosity solutions and applications (Heraklion, 1999)*, volume 59 of *Ser. Adv. Math. Appl. Sci.*, pages 197–219. World Sci. Publ., River Edge, NJ, 2001.
- [26] J. A. Sethian. *Level set methods and fast marching methods*, volume 3 of *Cambridge Monographs on Applied and Computational Mathematics*. Cambridge University Press, Cambridge, second edition, 1999. Evolving interfaces in computational geometry, fluid mechanics, computer vision, and materials science.
- [27] H. M. Soner and N. Touzi. Dynamic programming for stochastic target problems and geometric flows. *J. Eur. Math. Soc. (JEMS)*, 4(3):201–236, 2002.
- [28] H. M. Soner and N. Touzi. A stochastic representation for mean curvature type geometric flows. *Ann. Probab.*, 31(3):1145–1165, 2003.
- [29] P.E. Souganidis. Front propagation: theory and applications. In *Viscosity solutions and applications (Montecatini Terme, 1995)*, volume 1660 of *Lecture Notes in Math.*, pages 186–242. Springer, Berlin, 1997.
- [30] H. Zhao. A fast sweeping method for eikonal equations. *Math. Comp.*, 74(250):603–627 (electronic), 2005.