

PATTERNHOOD, CORRELATION, AND GENERALITY:
FOUNDATIONS OF A PEIRCEAN THEORY OF PATTERNS

Jimmy Jericho Aames

Submitted to the faculty of the University Graduate School
in partial fulfillment of the requirements
for the degree
Master of Arts
in the Department of Philosophy
Indiana University

July 2016

Accepted by the Graduate Faculty, Indiana University, in partial
fulfillment of the requirements for the degree of Master of Arts

Master's Thesis Committee

André De Tienne, Ph.D., Chair

Timothy Lyons, Ph.D.

Cornelis de Waal, Ph.D.

Acknowledgements

I would like to express my gratitude to Dr. Timothy Lyons, Dr. Cornelis De Waal, Dr. Samuel Kahn, and Dr. Chad Carmichael, who willingly shared their precious time to review my work and offer valuable comments and suggestions at various stages of writing. But above all I want to thank Dr. André De Tienne, without whose dedicated mentorship this work would have been impossible. It was Dr. De Tienne who initiated me into the labyrinthine world of Peirce's thought, and whatever I write will invariably bear the stamp of his influence.

Jimmy Jericho Aames
PATTERNHOOD, CORRELATION, AND GENERALITY:
FOUNDATIONS OF A PEIRCEAN THEORY OF PATTERNS

This thesis develops a general theory of patterns on the basis of the philosophy of Charles S. Peirce. The main questions with which this thesis is concerned are: what is the ontological status of patterns? In what does their reality consist in? Why does exhibiting patternhood seem to be a necessary condition for the very possibility of cognition? The development of the theory is motivated by a discussion of Ontic Structural Realism (OSR), a theory that has recently been gaining attention in analytic philosophy of science, especially in philosophy of physics. The central claim of OSR is that only patterns (structures) are real; individual objects are not real, or have only a “thin” being in some sense. In this thesis I deal mainly with the version of OSR developed by James Ladyman and Don Ross in their book *Every Thing Must Go*. I address two criticisms that are commonly levelled against OSR, (1) that it cannot give an adequate account of the difference between physical structure and mathematical structure, and (2) that it cannot give an adequate account of the relationship between the world and our representations of the world. I then show how Peirce’s philosophical framework, as encapsulated in his pragmatism, theory of the categories, Scholastic realism, and theory of the continuum, could provide an answer to these difficulties. OSR will also be used to illuminate an aspect of Peirce’s philosophy which I believe has not been sufficiently emphasized in the literature, namely its structuralist aspect. Specifically, it will be shown that Peirce’s philosophy leads to a worldview very similar to that of OSR, via a path of reasoning that is completely different from those standardly used to argue for OSR. This thesis as a whole is an attempt to throw light on the nature of patternhood through an elucidation and justification of this path of reasoning, which I call the *alternative path to OSR*.

André De Tienne, Ph.D., Chair

Table of Contents

| | |
|---|-----|
| Abbreviations | 1 |
| Introduction | 2 |
| 1. What is This Mysterious Thing Called <i>Pattern</i> ? | 10 |
| 1. 1. The Theoretical Background of OSR | 10 |
| 1. 2. Dennett's Theory of Real Patterns | 15 |
| 1. 3. The OSR of Ladyman and Ross | 19 |
| 1. 4. Problems with OSR | 25 |
| 1. 4. 1. Problem 1: The Physical/Mathematical Distinction | 25 |
| 1. 4. 2. Problem 2: The Concept of Representation | 36 |
| 2. Pragmatism as a Structuralist Theory of Meaning | 41 |
| 2. 1. Two Formulations of Pragmatism | 41 |
| 2. 2. Pragmatism as a Structuralist Theory of Meaning | 46 |
| 3. Peirce's Theory of the Categories | 52 |
| 3. 1. On a New List of Categories: General Outline | 52 |
| 3. 2. Reference to a Correlate | 59 |
| 3. 3. Semiosis and the Flow of Information | 73 |
| 4. Nominalism and Realism | 85 |
| 4. 1. Introduction of Terminology and Basic Framework | 87 |
| 4. 2. Peirce's Scholastic Realism | 92 |
| 5. Peirce's Theory of the Continuum | 100 |
| 5. 1. Secondness as the Category of Individuation | 101 |
| 5. 2. The Mathematical Theory of the Continuum | 103 |
| 5.3. Continuity, Generality, and the Inexhaustibility of Nature | 115 |

| | |
|--------------------------|-----|
| Concluding Remarks | 121 |
| References | 123 |
| Curriculum Vitae | |

Abbreviations

CP x.y = *Collected Papers of Charles Sanders Peirce*, volume x, paragraph y.

NEM x.y = *The New Elements of Mathematics*, volume x, page y.

SS: x = *Semiotic and Significs: The Correspondence Between Charles S. Peirce and Victoria Lady Welby*, page x.

Wx: y = *Writings of Charles S. Peirce: A Chronological Edition*, volume x, page y.

RLT: x = *Reasoning and the Logic of Things: The Cambridge Conferences Lectures of 1898*, page x.

EPx: y = *The Essential Peirce: Selected Philosophical Writings*, volume x, page y.

PM: x = *Philosophy of Mathematics: Selected Writings*, page x.

COWJ x: y = *The Correspondence of William James*, volume x, page y.

MS x: y = Manuscript housed in Harvard University's Houghton Library. The number x signifies the catalogue number assigned by Richard S. Robin in his *Annotated Catalogue of the Papers of Charles S. Peirce*; y is the sheet number.

L x: y = Correspondence housed in Harvard University's Houghton Library. The number x signifies the catalogue number assigned by Richard S. Robin in his *Annotated Catalogue of the Papers of Charles S. Peirce*; y is the sheet number.

Introduction

The central question with which this thesis is concerned is: what is a *pattern*? Everything that we experience in this world seems to have some sort of pattern, a regularity by which we are able to make sense of the things and events around us, and respond to them in appropriate ways. This is not to deny that there are purely random events, such as the “snow” noise that appears on analog TVs receiving no transmission signal. But even such noise must display some kind of regularity—in the case of the TV static, the noise is displayed on a TV screen, which is itself a regularity in space and time (and other dimensions, as we shall see), the noise consists of black and white pixels of the same size and shape, the distribution of black and white across a sufficiently large area is uniform, etc.—otherwise we would not be able to perceive the noise at all. It is true that the noise itself is not a regularity, yet it can be discerned only against the backdrop of a series of regularities. Exhibiting regularity seems to be a condition for the very possibility of cognition; but why should this be the case? What kind of mode of being does a pattern have? Furthermore, is there anything in the world that is not a pattern?

This thesis will be concerned primarily with the philosophy of Charles S. Peirce, in particular his pragmatism, theory of categories, and ideas on continuity. We shall see how Peirce can guide our way through the seemingly intractable maze of issues surrounding the concept of patternhood, and why it is no exaggeration to characterize him as a *philosopher of patterns*.

But before delving into Peirce’s philosophy, I would first like to take my point of departure in a theory called *Ontic Structural Realism* (OSR), a theory which has recently been gaining attention in analytic philosophy of science, especially in philosophy of physics. It was developed in the late 1990s by the British philosophers of science James Ladyman and Steven French, partly as a radicalization of the position called “structural realism” defended by John Worrall in the context of the scientific realism debate (Worrall 1989), and partly as a metaphysical theory motivated by the find-

ings of contemporary physics. In this thesis I will deal mainly with the version of OSR developed by Ladyman and Don Ross (the latter being an interdisciplinary scholar who does work on issues lying at the boundary between microeconomics, neuroscience, and philosophy) in their book *Every Thing Must Go* (Ladyman, Ross, et al. 2007; hereinafter abbreviated as ETMG).¹ As suggested by the title of the book, OSR is a theory that holds that only *structures* are real—individuals are not real. In Chapter 1 we shall discuss in more detail how we should understand the notions of *structure* and *individual*, as well as the main thread of argumentation that Ladyman and Ross give to support their version of OSR.

Ladyman and Ross use the terms “pattern” and “structure” synonymously, and so will I, although I prefer the term “pattern” because “structure” tends to evoke the image of a fixed, static entity, which in my view represents only a particular species of pattern. Another merit of the term “pattern” over “structure” is its inseparable connection with observation. As pointed out by Dennett (1991: 32), a pattern, by definition, must be a candidate for pattern *recognition*—an incognizable pattern is a contradiction in terms. The term “structure,” on the other hand, tends to evoke the image of an entity capable of subsisting independently of any relation with an observing mind; this is a crucial issue that we shall return to repeatedly throughout the thesis. My preference notwithstanding, I will continue to use both “pattern” and “structure” interchangeably, since the latter term is the one established in the philosophy of science literature. I believe there will be no danger in such a usage, as long as we keep in mind the caveats noted above.

¹ *Every Thing Must Go* is co-authored by four authors: James Ladyman, Don Ross, John Collier, and David Spurrett; Collier being a contributor to Chapter 4 and Spurrett being a contributor to Chapters 1 and 5. However, since Ladyman and Ross are displayed as the main authors on the cover and title page, I shall simply refer to the authors of the book as “Ladyman and Ross.” Collier, by the way, has written several papers on Peirce, particularly in connection with biosemiotics.

My reason for taking up OSR in this thesis is twofold. The first is to bring into relief the difficulties involved in thinking about patterns from the standpoint of a nominalist metaphysics. The main proponents of OSR, James Ladyman, Don Ross, and Steven French (Ladyman's mentor), argue for OSR using arguments from the philosophy of contemporary physics. They have a vague sense that patterns can be real, but they seem to lack the philosophical framework necessary for understanding what a pattern is, and thereby fall into the confusion of conceiving of patterns on the model of individuals, as I shall argue in this thesis. My taking up of OSR is meant to bring into relief this confusion and motivate our solution to it—a solution that will draw upon the ideas and resources of Peirce's philosophy. The other reason why I take up OSR is because I believe its central thesis, that only patterns are real, contains a deep truth about the constitution of our universe. The proponents of OSR, however, do not seem to realize this. The “deep truth” that I speak of has to do with what I will call the *alternative path to OSR*, a path of reasoning that suggests itself from the basic tenets of Peirce's philosophy, and which is completely different from the arguments standardly used to argue for OSR. I will return to the alternative path to OSR later in this Introduction.

Despite the counter-intuitiveness of its central claim, OSR has gained many followers over the years; but it has also been subject to a myriad of criticisms. One of the most serious objections leveled against OSR, in my view, is that it fails to give a sufficient account of the difference between mathematical structure and physical structure (e.g. Cao 2003; van Fraassen 2006). Is it possible to explain the difference between mathematical structure and physical structure in purely structural terms? A table, according to OSR, is not an individual object but a pattern, a regularity in the phenomena that can be discerned at certain grains of observational resolution. Now if we stumble into the pattern known as a table, it blocks our progress and injures us (Harman 2010: 782). Apparently we cannot “stumble into” a mathematical pattern in the same way. OSR must somehow explain this

difference. However, neither the authors of ETMG nor any of the other proponents of OSR seem to have addressed this issue satisfactorily. Ladyman and Ross are candid about this: in ETMG they simply “refuse to answer” the question as to what the difference between mathematical and physical structure consists in (ETMG: 158). Steven French does no better than this. In his recent tome, *The Structure of the World* (French 2014), he devotes an entire chapter to the question, but, as far as I am able to make out, fails to offer a compelling answer. In this connection, French’s response to Matteo Morganti’s (2011) accusation that OSR conflates general properties such as “bosonness” and “fermionness” with actual bosons and fermions is revealing: “I am suspicious of talk of ‘actual’ properties of ‘actual’ particles when the notion of ‘actual’ remains unarticulated” (French 2014: 197). Of course, it is the burden of the OSRist, not the opponent of OSR, to provide such an articulation; and French’s proposals involving “trope theory” and “mereological bundle theory” are inadequate. I will discuss this issue in more detail in Chapter 1.4.

A related issue concerns the notion of *representation*. Namely, when OSR claims that only structures are real, is it insisting that only the mathematical or formal structures embodied in our theories are real, or is it insisting that only the extra-representational structure of the world in itself, represented by those theories, is real? Being committed to realism, one would expect the OSRists to opt for the latter route, that only the extra-representational structure of the world in itself is real. But this gives rise to the problem of how to understand *truth*—when is a representation a true representation of the structure of the world? Should truth be understood in terms of an isomorphism between the representation and the world? But this is nonsense; isomorphism can only be defined to hold between mathematical structures. What exactly do we mean by the “world in itself” in the first place? Confronted with the question raised at the beginning of this paragraph in an interview, Ladyman responds: “this question gets to the heart of the matter and I must confess that I am not sure what the answer to it is” (Ladyman 2009: 166). Similarly, in response to the accusation that

OSRists are unable to give an appropriate account of the relationship between representations and the world in terms of those very representations, French simply dodges the issue by remarking that “all current forms of realism must face this accusation, not just OSR” (French 2014: 195.fn7).

I submit that both of these difficulties faced by OSR stem from a flawed understanding on the part of its proponents of what it means for something to be *real*. This flaw, in turn, is carried over into their conception of structure, as I hope to show in this thesis. What makes the OSR of Ladyman and Ross attractive is the way it breaks with the modes of thinking that philosophers trained in the analytic tradition of metaphysics are accustomed to.² Ladyman and Ross do not mince words in their criticism of analytic metaphysics. The Preface to ETMG begins: “contemporary analytic metaphysics ... fails to qualify as part of the enlightened pursuit of objective truth, and should be discontinued” (vii). Again: “We think the current degree of dominance of analytic metaphysics within philosophy is detrimental to the health of the subject, and make no apologies for trying to counter it” (vii). Nonetheless, as we shall see in Chapter 1.4, they still work within the general framework of analytic philosophy of science, in particular the scientific realism debate. And this, I believe, is the fundamental source of OSR’s flaw. What is needed to counteract the analytic tendency in the thought of Ladyman and Ross and complete their break with analytic metaphysics is a good dose of Peirce.

This should not be taken to mean, however, that the illumination will be unilateral. Not only will Peirce’s philosophy illuminate the issues faced by OSR, but OSR will also serve as an excellent frame of reference from which we can see Peirce’s overall philosophy in a new light. Specifically, we shall see how Peirce’s philosophy leads to a worldview very similar to that of OSR, via a path of reasoning that is completely different from those standardly used to argue for OSR: this is the *al-*

² Unfortunately, the same cannot be said of French’s version of OSR, which is why I concentrate on Ladyman and Ross’s version in this paper.

ternative path to OSR that was mentioned earlier. In Chapter 2 we will lay the groundwork for this path of reasoning, by showing how pragmatism can be understood as a “structuralist” theory of meaning. First I outline the basic idea behind Peirce’s pragmatic maxim by distinguishing between two distinct formulations of the maxim, which I call the *verificationist formulation* and *practicalist formulation*, and by discussing their relationship. Then, I proceed to exhibit the structuralism embodied in the maxim: it is structuralist in that it tells us to clarify our conception of objects in terms of the conceivable effects which they have *in relation to other objects*.

In order to appreciate the depth of Peirce’s pragmatism, however, it is necessary to examine its interconnectedness with his theory of categories. Peirce’s theory of categories will therefore be the topic of Chapter 3. The aim of this chapter will be twofold: first, to exhibit the operation of the three categories, Firstness, Secondness, and Thirdness, within the thought process and show how this operation manifests itself in the structuralism of the pragmatic maxim; and second, to show how the theory of categories can lead us to a conception of *representation* that does not fall prey to the second of the difficulties faced by OSR. My argument will focus on Peirce’s 1867 paper “On a New List of Categories.” After outlining the general strategy of his derivation of the categories in the paper, I will take up several competing interpretations of Peirce’s notion of *Reference to a Correlate*, which constitutes the second category, and offer my own interpretation. We shall then see how Thirdness may be understood as what may be called the *pure power of gluing*, that is, the power of bringing two hitherto detached objects of thought into relation. Finally, we shall see how the concept of *information* can be understood from the standpoint of Peirce’s theory of categories. This will allow us to see both a striking congruence and difference between Peirce’s model of semiosis, or the sign process, and Ladyman and Ross’s model of the self-replication of patterns in Chapter 4 of ETMG.

In Chapter 4 we turn to Peirce's Scholastic realism and see how it differs from realism as it is understood in contemporary Anglo-American philosophy, including OSR. After outlining Peirce's arguments against nominalism, I show that "realism" in the Anglo-American sense is really a species of nominalism in the Scholastic/Peircean sense. This will allow us to see that both of the difficulties faced by OSR derive from the fact that it is straddling two incompatible metaphysics: insofar as it takes structures to be real, it is realist (in the Scholastic/Peircean sense), since structures must be general. But insofar as it subscribes to a correspondence conception of truth, it is conceiving of structures as actual existents rather than as indeterminate laws—or in other words it is conceiving of structures on the model of individuals—and is therefore nominalist. The only way for the OSRist to be logically consistent is to expunge the residue of nominalism from his system and embrace Scholastic realism, which, as I will further argue, necessarily entails a form of idealism—an *objective idealism*, to use Peirce's phrase (EP1: 293, 1891).³

Our discussion in Chapters 3 and 4 will provide an answer to the second of the two difficulties faced by OSR, namely that it cannot give an account of the relation between our representations and the world in itself in terms of those very representations. Chapter 5 will be concerned mainly with how Peirce's approach can solve the first of the two difficulties faced by OSR, namely that it cannot give an account of the difference between mathematical and physical structure. In order to answer this problem, it is necessary to delve into Peirce's conception of *continuity*. My approach will be chronological, focusing on how Peirce's conception of the continuum evolved over his lifetime. This approach, I believe, will put into relief the issues that motivated Peirce's mature conception of the continuum as a "supermultitudinous" collection, a collection whose multitude is greater than that of any discrete multitude, and whose members are no longer distinct individuals but are "fused

³ For an explanation of the abbreviations used in referring to Peirce's writings, see the list at the beginning of this thesis.

together.” We shall see the implications of Peirce’s mathematical theory of the continuum for the distinction between physical structure and mathematical structure, and we shall also see how it can provide us with a way of understanding why exhibiting patternhood is a necessary condition for the very possibility of cognition.

The basic line of thought that will emerge as the result of our Peircean answer to the two difficulties faced by OSR is simple: exhibiting patternhood is a necessary condition for the possibility of cognition; cognizability is a necessary condition for something to be real; therefore, anything that is real must exhibit some kind of patternhood, or, which amounts to the same thing, anything that is real must be a pattern. We will thus be lead to the central thesis of OSR, but through a path of reasoning that is completely different from those standardly used to argue for OSR.

1. What is This Mysterious Thing Called *Pattern*?

1.1 The Theoretical Background of OSR

The aim of this chapter is to situate OSR within the broader structuralist approach to philosophy of science in recent analytic philosophy, outline its main claims and arguments, and address its shortcomings. In general, by *structuralist* I shall mean the tendency of thought which, in the investigation of phenomena, gives priority to relations over individual objects, and in some sense attempts to reconceive the latter in terms of the former. Structuralism can come in various forms depending on the type of concern it is motivated by (epistemological, methodological, or ontological), the domain of inquiry it is interested in, its conception of structure, etc. In this thesis I will deal mainly with the structuralist tradition in recent analytic philosophy of science, and will not address in any detail the various other strands of structuralism, such as the Neo-Kantian strand of Hermann Cohen, Ernst Cassirer, and Henri Poincaré in the late 19th and early 20th centuries, the group-theoretic structuralism of the physicists Sir Arthur Eddington and Hermann Weyl, the “logical” structuralism of Bertrand Russell and Moritz Schlick, and the French structuralist tradition originating in Ferdinand de Saussure’s approach to linguistics; although brief mention will be made of some of these thinkers in my discussion of OSR.

The structuralist approach in analytic philosophy of science was instigated by John Worrall, who advocated a position which he called “structural realism” (Worrall 1989). This position was motivated as a response to Larry Laudan’s so-called Pessimistic Meta-Induction in the context of the scientific realism debate (Laudan 1981). By citing examples from the history of science, Laudan argues against what he calls “convergent realism,” a view which holds that successive theories in any mature science preserve the theoretical relations and referents of preceding theories, and that science therefore makes cumulative progress. He observes that most past theories which were em-

empirically successful have nonetheless been discarded and regarded as false. Therefore, by enumerative induction, we should expect current empirically successful theories to be ultimately discarded and regarded as false as well. Against this, Worrall distinguishes those parts of scientific theories which are discarded and those parts which are “carried over” in the process of theory change. Citing as an example the transition from Fresnel’s elastic solid ether theory to Maxwell’s theory of the electromagnetic field, he observes that “[t]here was continuity or accumulation in the shift, but the continuity is one of form or structure, not of content” (Worrall 1989: 117). We can be pessimistic about the reality of substantive entities that are posited by our scientific theories, but we do not thereby have to embrace the empirical success of those theories as a sort of cosmic miracle:

Roughly speaking, it seems right to say that Fresnel completely misidentified the *nature* of light, but nonetheless it is no miracle that his theory enjoyed the empirical predictive success that it did; it is no miracle because Fresnel’s theory, as science later saw it, attributed to light the right *structure*. ... There is no elastic solid ether. There is, however, from the later point of view [of Maxwell’s theory], a (disembodied) electromagnetic field. The field in no clear sense approximates the ether, but disturbances in it do obey formally similar laws to those obeyed by elastic disturbances in a mechanical medium. (Worrall 1989: 117–18)

Thus we can be realists about the form or structure described by our best scientific theories, while remaining agnostic about the nature of the entities which bear those formal relations.⁴

But what is meant by this “nature”? Positing such an incognizable seems to open an insurmountable gap between epistemology and ontology. This is no coincidence, for Worrall’s structuralism is motivated by epistemological issues in the context of the realism debate, and does not con-

⁴ Of course, we should distinguish the claim that there are non-structural entities whose natures are unknowable from the claim that it is unknowable whether there are non-structural entities in the first place. Worrall seems to have moved recently from the former position to the latter (see Worrall 2012). This distinction will have no bearing on my discussions in this thesis.

cern itself with the metaphysical questions raised by current science. This is where OSR enters the scene. As mentioned in the Introduction, OSR is a theory motivated by the metaphysical implications of contemporary physics, and as such it goes beyond the merely epistemological concerns of Worrall's structuralism; advocates of OSR call the latter *Epistemic Structural Realism* (ESR) to distinguish it from their own position. The difference between ESR and OSR can be succinctly summarized in the following way: ESR claims that structure is all that we can know, that is, individuals are unknowable; while OSR claims that only structure is real, that is, individuals have no being (or have only a "thin" being in some sense).

Here, it is a good idea to have a working definition of the key term *individual*. An individual can be characterized as a putative entity which bears the properties and relations prescribed by a theory or set of beliefs, and which can subsist independently of relation to anything else. This may seem to be a rather restrictive definition, since, according to this definition, a person would not be an individual. In response to this potential objection, I will here note a distinction that I will discuss more fully in Chapter 4.1: the distinction between a *relative individual* and *absolute individual*. A *relative individual* is anything that satisfies the definition stated above *relative to some particular purpose or inquiry*. Thus, a person can be regarded as an individual from the standpoint of commonsense or "folk" psychology, insofar as we normally consider a person as capable of subsisting independently of relation to anything else, at least for the purposes of everyday communication, explaining and predicting actions, etc. However, if we adopt the perspective of the biologist, a person can no longer be regarded as an individual, since a person is dependent upon food, water, oxygen, and so on in order to sustain life. An *absolute individual* is anything that satisfies the definition stated at the beginning of this paragraph *regardless of any particular purpose or inquiry*. Thus, a person is a relative individual but not an absolute individual. Later, we shall see that a pattern cannot be an absolute individual, although it can be a relative individual (Chapter 4.1).

It would not be a very interesting task to inquire into whether there are such things as relative individuals; it seems rather indisputable that there are individuals in this sense. The more interesting question—the question addressed by OSR—is whether there are such things as absolute individuals. As pointed out by Ladyman and Ross (ETMG: 1–7, 17–27), many philosophers seem to hold that reality “bottoms out” at some fundamental level of absolute individuals, such as the level of atoms or quarks, or at least proceed upon the assumption that this is a genuine possibility. The claim of OSR, of course, is that this is not the correct way of looking at the world. I will have more to say about the definition of *individual* in Chapter 4.1. Until then, whenever I use the term *individual*, I will use it in the sense of *absolute individual*, since it is the possibility of absolute individuals that OSR is concerned with.

There is one more potential confusion that should be dispelled at this point. It is crucial to distinguish an individual from a general *object-concept*. The general concept of a hydrogen atom would be an example of the latter, while (assuming that an atom is an individual) the hydrogen atom here and now would be an example of the former. The proponents of OSR themselves seem to slide on occasion from talk about individuals to talk about general object-concepts, and vice versa.⁵ But it is clear that the central tenet of OSR is the elimination (or reduction in some sense) of individuals rather than object-concepts, for the theory is grounded on arguments concerning the identity conditions of quantum particles and space-time points (ETMG, Chapter 3). Keeping this distinction clear, let us turn to the motivations of OSR.

There are several different ways of arguing for OSR, depending on the domain of inquiry one is interested in. Perhaps the foremost motivation of the theory is, as mentioned above, the issue of the individuality of quantum particles in many-particle quantum theory, raised by a form of symmetry in quantum statistics known as *permutation invariance*. Suppose we have two boxes, A and B, and

⁵ As pointed out by Morganti (2011). See p. 4 above.

we want to distribute two particles i and j among them. In a classical system there are four possible arrangements: (1) both i and j in box A; (2) both i and j in box B; (3) i in box A and j in box B; and (4) i in box B and j in box A. In a quantum system, however, there are only three possible arrangements: the particles are indistinguishable from one another, and therefore the two cases in which there is one particle in each box are regarded as identical. Thus we say that the wave function of the system remains invariant under the permutation of particles. From this one could attempt to argue directly that quantum particles are non-individuals, but Ladyman and French's argument is a bit different. Namely, they note that the physics is also compatible with a view of quantum particles as individuals, and then they go on to argue that it is this underdetermination of interpretation that ultimately compels us to dispense with individuals (French and Ladyman 2003: 36–37). The idea seems to be that the reason why the formalism of quantum mechanics cannot uniquely determine its interpretation is because the notion of “individuality” is fundamentally ambiguous and plays no explanatory role in the first place: “It is an *ersatz* form of realism that recommends belief in the existence of entities that have such ambiguous metaphysical status” (Ladyman 1998: 420).

Thus runs the standard argument for OSR from non-relativistic quantum mechanics.⁶ OSR has also been developed in quantum field theory (Kantorovich 2003; Lyre 2004) and general relativity (Rickles 2006; Esfeld and Lam 2008). In addition to these various motivations, there are differences in the conception of *structure* among proponents of OSR. Thus, Ladyman and Ross conceive of structure in terms of “patterns,” elaborating on the theory of *real patterns* outlined by Daniel Dennett (1991), while French (2014) goes back to the group-theoretic structuralism of Cassirer, Eddington, and Weyl and emphasizes the importance of group theory in understanding structure. Since

⁶ See also F. A. Muller's (2009) argument for OSR from the fact that quantum particles are only weakly discernible, that is, discernible via permutation-invariant binary relations such as “has opposite spin to.”

in this thesis we are concerned with the OSR of Ladyman and Ross, it behooves us to examine in detail Dennett's theory of real patterns, from which Ladyman and Ross draw their inspiration, and upon which their version of OSR is based.

1.2 Dennett's Theory of Real Patterns

Dennett's main concern in his paper on the theory of real patterns (1991) is the ontological status of what he calls *intentional states*—beliefs, desires, and the like. The question he asks is: are intentional states real in some sense, or are they mere figments of the imagination, perhaps useful fictions, but nonetheless fictions? In order to answer this question, he develops a theory of the ontological status of patterns in general, of which intentional states are a special case (namely, patterns of bodily movements, vocalizations, etc.). It is this theory of patterns in general that interests us here.

In the most general terms, a pattern is a regularity in some data, where *data* is construed in the broadest possible sense as something that is observed or may be observed. Consider, for example, an endless random string of 0's and 1's. There is no regularity in this data. On the other hand, consider an endless string of alternating 0's and 1's: 010101010 ... etc. What we should notice is that this data can be compressed into a program that commands: "generate an endless string of alternating 0's and 1's." There is no way of compressing the random string of 0's and 1's—the only way this data can be transmitted to another person is to send the *bit map*, which identifies each digit *seriatim* (the first place value is 0, the second place value is 0, the third place value is 1, etc.). In more general terms, a bit map is a zero-compression encoding, where each bit of information in the initial data is mapped one-to-one to a distinct bit in the encoding. Thus, building on Gregory J. Chaitin's definition of randomness,⁷ Dennett proposes the following criterion for the presence of a pattern:

⁷ "A series of numbers is random if the smallest algorithm capable of specifying it to a computer has about the same number of bits of information as the series itself" (Chaitin 1975: 48).

“A pattern exists in some data—is real—if there is a description of the data that is more efficient than the bit map, whether or not anyone can concoct it” (Dennett 1991: 34). That is, there is a pattern in some data if there is an algorithm that reproduces the data using a smaller number of bits than the data itself (when there is such an algorithm, we say that the data is *algorithmically compressible*).

An interesting aspect of pattern recognition is that not all observers are able to discern the same pattern in the same data, and even the same observer may discern different patterns in the same data on different occasions. The famous duck-rabbit illusion is a prime example of the latter. As another example, suppose that an image file—say a jpg image of a human face—is translated into binary notation, pixel by pixel. The pattern is still there, but it would be impossible for the human eye to discern the pattern visually. Other creatures with different sense organs may readily perceive patterns that are imperceptible to us (Dennett 1991: 34). Hence Dennett’s proviso that the presence of a pattern should not depend on whether or not anyone is actually able to concoct a compression algorithm: there is a pattern in some data if the data is *in principle* compressible by a potential observer.

Dennett’s criterion specifies a necessary and sufficient condition for the *presence* of a pattern, but it does not by itself guarantee that the pattern is *real*, i.e. that it has a mind-independent being.⁸ This is because we can make *false generalizations*—we may happen to discern patterns that are due to pure chance, for example, and mistake them for having a real being. Dennett himself is clear throughout his paper that not all patterns are real—there are non-real as well as real patterns, and we need some criterion other than algorithmic compressibility for distinguishing between the two. To

⁸ The definition of “real” as “mind-independent” is not Dennett’s but is due to Peirce (and Duns Scotus); hence Dennett’s use of “real” as synonymous with “exist”: “A pattern exists in some data—is real—if there is a description of the data ...” (1991: 34). Dennett’s use of the term “real” in the paper is, unfortunately, not very clear, as I mention below. A more rigorous discussion of the notion of mind-independency will be given in Chapter 4.1.

take Dennett's example, the *center of gravity* of a given body expresses a real pattern (namely, a pattern in the motions of that body), whereas the *center of population* of the United States—which he defines as “the mathematical point at the intersection of the two lines such that there are as many inhabitants north as south of the latitude, and as many inhabitants east as west of the longitude” (Dennett 1991: 28)—does not express a real pattern (although it does express a pattern).⁹ They are both abstractions, but the former is somehow a *good* abstraction, while the latter is a bad one. In what sense is the former abstraction good? Dennett's answer—an answer which, as we shall see, accords with Peirce's argument for Scholastic realism—is that a center of gravity is an abstraction that leads to *successful predictions* about future events. As he puts it, a pattern is real if you can get rich by betting on it (Dennett 1991: 36). Although Dennett himself is not altogether clear on the relation between his algorithmic compressibility criterion and predictive potential criterion (most likely due to his equivocal use of the term “real”), it is safe to assume that the former constitutes a necessary and sufficient condition for the *presence* of a pattern, regardless of whether it has a real being or not, while the latter constitutes a necessary and sufficient condition for the *reality* of a pattern.

Mention of predictive potential brings us back to our earlier consideration, that not all observers are able to discern the same pattern in the same data, and that even the same observer may discern different patterns in the same data on different occasions. This means that patterns are in some sense *observer-dependent*. Dennett explicates this notion in terms of predictive potential: patterns are ob-

⁹ In case the reader may suspect that the center of population of the United States *is* a real pattern, I add Dennett's alternative example: “I doubt that this abstract object [the center of population of the United States] is of any value at all in any scientific theory, but just in case it is, here is an even more trivial abstract object: Dennett's lost sock center: the point defined as the center of the smallest sphere that can be inscribed around all the socks I have ever lost in my life” (Dennett 1991: 28).

server-dependent in that they can be discerned only from the point of view of an observer that adopts a certain predictive strategy, or *stance*, to use Dennett's terminology.¹⁰ For instance, Dennett calls the predictive strategy from which intentional states can be discerned the *intentional stance* (Dennett 1987: 17). Likewise, there can be predictive strategies for discerning any kind of pattern whatsoever: the Newtonian mechanics stance, the cellular biology stance, the microeconomic stance, etc. The idea is that patterns are not simply "out there," naked in the world; on the contrary, the recognition of a pattern must always involve an element of active participation on the part of the observer, namely the adoption of a certain predictive strategy. This should not be taken to mean, of course, that the act of adopting a predictive strategy is always a conscious, deliberate act: the decision of which predictive strategy to adopt is dictated to large degree by the structure of our sense organs, our genetic makeup, and the evolutionary history of our culture (Dennett 1991: 36).

Patterns thus have an observer-dependent being; but at the same time, they are in another sense *observer-independent*. They are observer-independent in that the facts about the success or failure of our predictive strategies do not depend on what we may think or will—they are completely out of our control. It is this uncontrollability of the outcome of our predictions that imparts to some patterns—namely, those whose discernment leads to successful predictions—a mind-independent, and hence real, being.

Thus in outline is Dennett's theory of real patterns. As we shall see later when we consider Peirce's philosophy, Dennett's theory of real patterns can be said to be a revival, in modern garbs, of the doctrine of Scholastic realism, according to which universals have a real being. It is a sugges-

¹⁰ "[W]hile belief is a perfectly objective phenomenon ... it can be discerned only from the point of view of one who adopts a certain predictive strategy, and its existence can be confirmed only by an assessment of the success of that strategy ..." (Dennett 1987: 15). Although the claim here is couched in terms of intentional states and the intentional stance, the statement can be generalized to hold for any kind of pattern recognition.

tive fact that Dennett's theory has come under criticism from all sides of the debate on the ontological status of intentional states, as Dennett himself notes (1989: 37–42; 1991: 27–31). Namely, it has been attacked as being *not realist enough* by those who hold that intentional states are “real” in the sense that they reflect or correspond to “mental facts,” ultimately traceable to brain states; and at the same it has been attacked as being *too realist* by those who hold that intentional states are merely useful fictions. I am inclined to think that this reveals just as much about the deep-seated preconceptions of philosophers trained in the analytic tradition, as it does about the nature of Dennett's theory.

1.3 The OSR of Ladyman and Ross

Succinctly put, the central thesis of OSR is that there is no bit map representation of the world: “it's real patterns all the way down” (ETMG: 228). OSR does not deny the reality of everyday objects like tables and chairs, nor the objects studied by the special sciences, but it denies that they are individuals. What we traditionally conceive as individual “things” are reconceived as real patterns, discernable at certain grains of observational resolution (a notion that evidently corresponds with Dennett's notion of *stance*): “Some real patterns ... behave like things, traditionally conceived, while others behave like traditional instances of events and processes” (ETMG: 121). Of course, a non-OSRist may agree with this, and yet hold that reality “bottoms out” at some fundamental level of individual objects, such as the level of quarks and leptons. The radicalness of OSR consists in its claim that reality does not “bottom out” at a fundamental level; and indeed, Ladyman and Ross reject the very idea that there are “levels of reality”, on the grounds that it is a metaphor unsupported by current science (ETMG: 53–57).

Ladyman and Ross argue for their version of OSR by appealing to contemporary physics, in particular to the permutation invariance of quantum particles discussed above (ETMG: 132–140), but also to the so-called “hole argument” in general relativity (ETMG: 141–145), and to considerations

of quantum gravity (ETMG: 167–175) and quantum information theory (ETMG: 183–189). For our purposes, it is not the details of these arguments that are significant, but the fact that all of these arguments come from physics—and in particular, from *fundamental* physics rather than phenomenological physics such as fluid dynamics or optics.¹¹ One may wonder how Ladyman and Ross are able to argue for a metaphysical theory, which applies to all aspects of reality and not just to physics, from a consideration of fundamental physics alone. The answer lies in what they call the *Primacy of Physics Constraint*, a methodological rule prescribing an asymmetry between fundamental physics and all other branches of science:

Special science hypotheses that conflict with fundamental physics, or such consensus as there is in fundamental physics, should be rejected for that reason alone. Fundamental physical hypotheses are not symmetrically hostage to the conclusions of the special sciences. (ETMG: 44)

Thus, for Ladyman and Ross, fundamental physics is not just one science among many, but occupies a special status. It is on the basis of this rule that they are able to draw metaphysical conclusions from considerations of fundamental physics alone: insofar as fundamental physics compels us to believe in OSR, OSR must be valid not only for fundamental physics but across the board.

Given their self-avowed “scientism” (ETMG: 61) and privileging of fundamental physics, readers familiar with the analytic philosophy literature may expect Ladyman and Ross to be physical reductionists, that is, those who hold that everything—everyday objects, events, and processes as well as objects, events, and processes studied by the special sciences—can in some sense be “reduced” to fundamental physics. However, Ladyman and Ross reject all forms of reductionism, alt-

¹¹ By fundamental physics, I mean (non-relativistic) quantum mechanics, general relativity, quantum field theory, and theories of quantum gravity. Whether thermodynamics should also be understood as part of fundamental physics is an open question.

though they do acknowledge the existence of what are known as Nagelian reductions, that is, deductive explanations of a theory by another theory, such as the explanation of the Boyle-Charles Law for ideal gasses by statistical mechanics (ETMG: 45–53). With what Graham Harman has called an “admirable strangeness” (2010: 778), Ladyman and Ross argue that all of the patterns that we come across at everyday scales of observation, as well as those studied by the special sciences, have an autonomous being, irreducible to the patterns studied by fundamental physics or other special sciences, as long as they satisfy the criteria for real patternhood (to be discussed shortly). Thus, in opposition to W. V. O. Quine’s recommendation of “desert” ontologies—meaning that ontologies should be as sparse as possible—Ladyman and Ross endorse a view that they call *Rainforest Realism*, according to which there are diverse, autonomous realities at many different scales of observation: “[Our realism] is thus a realism of lush and leafy spaces rather than deserts, with science regularly revealing new thickets of canopy” (ETMG: 234).

What then, it may be asked, makes fundamental physics special, if not the reducibility of everything to it? Ladyman and Ross’s answer is that the asymmetry between fundamental physics and the other sciences derives from the fact that fundamental physics has a *universal* validity, whereas the other sciences are valid only for restricted sub-systems of the universe: “a science is special iff it aims at generalizations such that measurements taken only from restricted areas of the universe, and/or at restricted scales are potential sources of confirmation and/or falsification of those generalizations” (ETMG: 195). On the other hand, fundamental physics is that science which studies real patterns for which measurements are maximally redundant, that is, real patterns for which measurements taken *anywhere* in the universe, irrespective of the scale of measurement, carry information (ETMG: 251). That fundamental physics is possible—or equivalently, that there are maximally redundant real patterns—is tantamount to the hypothesis that the universe is unified rather than dabbled (ETMG: 251).

Let us next turn to Ladyman and Ross's (or rather, Ross and John Collier's, judging from the content of Chapter 4 in which the discussion of real patterns takes place) definition of real patterns, and see how they elaborate on Dennett's theory. Ladyman and Ross's main complaint against Dennett's criterion for the reality of patterns is that it is not stringent enough—on their view, the facilitation of successful predictions specifies a *necessary* condition for the reality of a pattern, but not a *sufficient* condition. They refer to an idea developed by Dennett in one of his early works on philosophy of mind (Dennett 1971), concerning the *indispensability* of the intentional stance in making predictions about certain systems. For example, it is *possible* for someone to assume the intentional stance to predict the behavior of a thermostat—"It prefers the room to be 68 degrees and believes it is now 64 degrees, so it decides to turn on the furnace"—but one *must* assume the intentional stance towards a chess-playing computer, in order to not lose predictive power (ETMG: 206). In the case of the thermostat, the intentional stance is possible but dispensable, whereas in the case of the chess-playing computer, the intentional stance is *indispensable*: if one were to dispense with the intentional mode of data compression, then they would find it far more difficult—perhaps even impossible—to predict the computer's next move.

Now the *indispensability of a mode of compression* is equivalent to the *impossibility of further compression*. For suppose that further compression of the given data is possible without sacrificing predictive power. Then the initial mode of compression can be dispensed with, since there would be a redundancy in it. Taking the contrapositive, if a mode of compression is indispensable, then the data cannot be further compressed without sacrificing predictive power. Conversely, if further compression is impossible without sacrificing predictive power, then evidently the given mode of compression cannot be dispensed with. Therefore, the indispensability of a mode of compression is equivalent to the impossibility of further compression of the data. This is clearly a more stringent condition for the reality of a pattern than that it should lead to successful predictions.

But the question is: indispensable for whom? Ladyman and Ross accuse Dennett of suggesting in his real patterns paper that indispensability should be relativized to a given level of error tolerance on the part of the observer—this, they argue, is too instrumentalist (ETMG: 206). It seems to entail that there is no indispensability condition at all, since any mode of compression is presumably indispensable at *some* level of error tolerance. According to Ladyman and Ross, the indispensability of a mode of compression ought not to be relativized to the computational capacity of some arbitrarily distinguished computers in some arbitrarily limited observational circumstances, such as a group of humans (ETMG: 208); otherwise we would fall into instrumentalism. Rather, the sufficient condition for the reality of a pattern should be the indispensability of the associated mode of compression—or equivalently, the impossibility of further compression—by *any physically possible computer* (ETMG: 221). Whether a given computation is physically possible can be determined by calculating the lower bounds of the energy required to effect that computation, for example by using Landauer’s Principle (ETMG: 208). This, according to Ladyman and Ross, is the only way that we can make sense of Dennett’s claim that there are real patterns that no person has yet discovered, or will ever discover, encapsulated in his proviso “whether or not anyone can concoct it [a compression algorithm]” in his formulation of the criterion for the presence of a pattern (see Chapter 1.3 above).

On the basis of these considerations, Ladyman and Ross formulate their theory of ontology, using their unique terminology, as follows:

To be is to be a real pattern; and a pattern $x \rightarrow y$ is real iff

- (i) it is projectible; and
- (ii) it has a model that carries information about at least one pattern P in an encoding that has logical depth less than the bit-map encoding of P, and where P is not projectible by a physically possible device computing information about another real pattern of lower logical depth than $x \rightarrow y$. (ETMG: 233)

Here, a pattern is characterized as a mapping “ $x \rightarrow y$ ” because Ladyman and Ross define patterns recursively, in relation to a device’s predictive computation of that pattern; this captures the observer dependence of patterns noted in the previous section. x is the observed pattern, while y is the output of a predictive computation of x by a device running a simulation of x . y is itself a further pattern, which can in turn be simulated by another device, whose output we shall denote as z . Supposing patternhood to be preserved across simulations, if $x \rightarrow y$ is a pattern, then $y \rightarrow z$ is also a pattern. The base case of the recursive definition is, according to Ladyman and Ross, constituted by the situation in which we cannot say anything about what x is, but can only “locate” it (ETMG: 266). Starting from this “pattern-in-itself,” patterns are constructed one by one, y observing x , z observing y , and so on *ad infinitum*. This way of defining patterns is likely intended to capture the manner in which patterns tend to *replicate* themselves, that is, to transmit their Form to an interpretive agent, so that that agent will also be under the governance of that same Form—a process commonly referred to as the “flow” of information.¹²

To say that a pattern is *projectible* is Ladyman and Ross’s way of saying that it leads to successful predictions—it is shorthand for *projectible into the future*, or generalizable into unobserved cases. More specifically, projectibility is a better-than-chance estimatability of a pattern by a physically possible computer running a non-trivial program (ETMG: 224). *Logical depth* is a quantitative measure of the informational content of a pattern, introduced by Charles H. Bennett.¹³ What condi-

¹² Or as Ladyman and Ross put it, the “dynamic propagation of temporally asymmetric influences” (ETMG: 210). I will have more to say about information “flow” in Chapter 3.3.

¹³ Bennett defines the *logical depth* of an object as “the time required by a standard universal Turing machine to generate it [the object] from an input that is algorithmically random” (1988: 227).

tion (ii) says, essentially, is that further compression of the pattern should be impossible by any physically possible computer, without sacrificing projectibility.

Whether Ladyman & Ross's reformulation of the theory of real patterns is an improvement over Dennett's theory is an issue that will not be addressed in this thesis. It will have little, if any, bearing on our main topic. My intention in introducing the reformulation is to familiarize the reader with the general orientation of Ladyman and Ross's version of OSR, and to highlight its connections with Peirce's theory of categories, to which we shall turn in Chapter 3.

1.4 Problems with OSR

As mentioned in the Introduction, there are, I believe, two major difficulties faced by OSR. One is that it is unable to give a satisfactory account of the difference between mathematical and physical structure, and the other is that it is unable to give a satisfactory account of the relation between the world and our representations of the world. I shall first address the former.

1.4.1 Problem 1: The Physical/Mathematical Distinction

One of the most serious objections levelled against OSR—perhaps *the* most serious—is that it conflates the mathematical and the physical, the “abstract” and the “concrete.”¹⁴ Here is Bas C. van Fraassen's objection:¹⁵

[OSR] must imply: *what has looked like the structure* of something with unknown qualitative features *is actually all there is to nature*. But with this, the contrast between structure and what is not structure has disappeared. Thus, from the point of view of one who adopts this position, any difference between it and ‘ordinary’ sci-

¹⁴ I enclose the terms *abstract* and *concrete* in scare quotes because I am not comfortable with this terminology. The important distinction here is between physical structure and mathematical structure; and physical/mathematical is not coextensive with concrete/abstract. An electric field is a physical structure, but is it *concrete*? In the absence of a precise definition, I think it is best to avoid the use of these terms altogether.

¹⁵ A similar complaint is voiced by Cao (2003).

entific realism also disappears. It seems then that, *once adopted*, it should not be called structuralism at all! For if there is no non-structure, there is no structure either. (van Fraassen 2006: 292–93)

Essentially, the objection here is that *existence* cannot be explained in purely structural terms. Something other than structure must be introduced in order to differentiate between structures that we know exert a governing power over actual existents (that is, physical structures), and structures such that we do not know if they have any such influence on actual existents, or if they have only a possible being (that is, mathematical structures). In other words, if there is no non-structure, then physical structure collapses into mathematical structure, and the latter by itself does not imply the actual existence of anything, including physical structure. Van Fraassen further elaborates on this point (although his use of the terms “abstract” and “concrete” is not very helpful):

There are many familiar examples in which we attribute properties to properties. The statement ‘Orthogonality is symmetric’ and ‘Orthogonality is invariant under Euclidean transformations’ are good examples. Such statements do not imply the existence of anything but abstract entities: properties or relations like orthogonality and properties of properties like symmetry or invariance. So if God had—so to speak—decided not to create nature at all, nothing at all that belongs to the proper domain of physics, those statements would still have been true. The statement ‘X is multiply instantiated’, where X is some property or relation like orthogonality, must be different from this. If God had decided not to create anything concrete, then that statement would have been false. Therefore, taking the contrapositive, if such a statement is true, then there exist concrete entities, therefore entities other than properties and relations. (van Fraassen 2006: 294)

The crucial question, then, is what we mean by *instantiation*; what do we mean when we say, for example, that “X is multiply instantiated”? Ladyman and Ross remark in passing that “there is an *analogy* here with the theory of universals and the problem of exemplification” (ETMG: 158.fn.53, emphasis mine), but actually it *is* the problem of universals and exemplification. It is unfortunate

that, despite the profundity of many of their insights, Ladyman and Ross invest little effort in engaging with traditional philosophical issues in their book, in particular with the problem of universals, which I believe is the heart of the matter here. This lack of interest most likely stems from their disparaging attitude towards traditional philosophy.¹⁶

Their brief remark about the theory of universals notwithstanding, Ladyman and Ross's answer to the question concerning the physical/mathematical distinction is, as we saw in the Introduction, is that they do not have an answer: "What makes the structure physical and not mathematical? That is a question that we refuse to answer" (ETMG: 158). Of course, they do have reasons for refusing to answer the question, indeed two reasons. One of them has to do with what they call the *Principle of Naturalistic Closure* (PNC), which they formulate as follows (I omit their stipulations regarding terminology):

Any new metaphysical claim that is to be taken seriously at time t should be motivated by, and only by, the service it would perform, if true, in showing how two or more specific scientific hypotheses, at least one of which is drawn from fundamental physics, jointly explain more than the sum of what is explained by the two hypotheses taken separately ... (ETMG: 37)

This principle is intended to delimit the domain of what Ladyman and Ross consider to be valid metaphysics. Anything that does not meet the criterion specified in this principle is to be denounced as non-naturalistic and hence unscientific. The principle itself reflects Ladyman and Ross's view of

¹⁶ As a typical example of Ladyman and Ross's attitude towards traditional philosophy, consider the following remarks: "We ask the reader to consider whether the main metaphysical idea we propose, of existent structures that are not composed out of more basic entities, is any more obscure or bizarre than the instantiation relation in the theory of universals. We think it better to attempt to develop the metaphysics presented in this book than to continue to use off-the-shelf metaphysical categories inherited from the ancient Greeks that are simply not appropriate for contemporary science or mathematics" (ETMG: 155–56).

metaphysics as an attempt to “unify hypotheses and theories that are taken seriously by contemporary science” (ETMG: 1). The proviso that at least one of the hypotheses to be unified must come from fundamental physics is intended to prevent metaphysics from becoming one of the special sciences—a theory that attempts to unify hypotheses drawn from biology and chemistry, for example, would presumably be part of one of those two fields.

It is by appealing to this principle that Ladyman and Ross refuse to answer the question concerning the physical/mathematical distinction: “In our view, there is nothing more to be said about this [the physical/mathematical distinction] that doesn’t amount to empty words and venture beyond what the PNC allows” (ETMG: 158). Interestingly, they then go on to claim that “The ‘world-structure’ just is and exists independently of us and we represent it mathematico-physically via our theories” (ETMG: 158).¹⁷ Of course, it is precisely the notion of *existence* that is at stake here, so simply asserting that “the ‘world structure’ exists” is not very illuminating. Moreover, what is striking about this sentence is that there is a substantial amount of non-PNC-compatible metaphysical assumptions packed into it. As we shall see shortly (in our discussion of the second difficulty faced by OSR) and in Chapter 4, this statement is a typical expression of the doctrine of *nominalism*, that universals have only a mind-dependent being. Immediately after Ladyman and Ross claim to have banished speculative metaphysics from their system with their so-called PNC, we see that it has crept in through the back door. I will have occasion to discuss issues regarding the meth-

¹⁷ To be fair, it should be noted that this statement is due not to Ladyman and Ross but to French and Ladyman, since it is taken verbatim from French and Ladyman (2003: 45). My contention will be that Ladyman and Ross’s OSR is straddling two incompatible metaphysics, nominalism and realism; but I suspect that the nominalist elements are due mainly to Ladyman (and the influence of his mentor French), while the more realist ideas are due mainly to Ross and perhaps Collier.

odology of metaphysics in Chapter 4; here I shall simply note that I take seriously Peirce's following dictum:

Find a scientific man, who proposes to get along without any metaphysics [which is what Ladyman and Ross do by restricting metaphysics to what is allowed by the PNC] ... and you have found one whose doctrines are thoroughly vitiated by the crude and uncriticized metaphysics with which they are packed ... Every man of us has a metaphysics, and has to have one; and it will influence his life greatly. Far better, then, that that metaphysics should be criticized and not be allowed to run loose. (CP 1.129, c.1905)

This should not be taken to mean, however, that we have no choice but to engage in *a priori* metaphysics, relying on our intuitions as evidence of the truth or falsity of hypotheses. I fully endorse Ladyman and Ross's criticism of the use of intuition in philosophy (ETMG: 10–15). But from this it does not follow that metaphysics should be relegated to the position of handmaiden of the sciences, as mandated by the PNC.

The other reason that Ladyman and Ross refuse to answer the question concerning the physical/mathematical distinction is because they are attracted by the idea that there is no distinction between the physical and the mathematical. Although they do not explicitly endorse the view, they offer various reasons for believing in "the identity of structures in mathematics and physics, and abandoning the distinction between the abstract structures employed in models and the concrete structures that are the objects of physics" (ETMG: 159). Now if the claim were that the difference between the physical and mathematical is one of degree rather than kind, then that is surely a sound claim. To suppose otherwise would make it impossible to explain the relationship between the physical and mathematical, in much the same way that Descartes's mind-body dualism made it impossible for him to explain the relationship between mind and body. But even if the difference were merely one of degree, there would still be a difference. To deny that there is *any* difference between

the physical and mathematical is tantamount to overlooking the fact that we live in an actual world of actions and reactions. The reasons that Ladyman and Ross give for believing in the identity of physics and mathematics all come from physics: they emphasize how contemporary physics is becoming more and more abstract, and how the traditional notion of matter is becoming more and more ephemeral. Yet, whatever physics may disclose to us will not alter the fact that we live in an actual world rather than a merely possible one.

The core of the issue, as I see it, is this: physics (or any other science) can only give us a *general* description or explanation of its object of study. When a physicist makes a statement about electrons, for example, he is not concerned with this or that particular electron but with electrons *in general*. But a general description or explanation can in no way differentiate between the actual and the merely possible—a dream may have all the general characters of the actual world and yet fail to be the actual world. What is needed for a general description or explanation to relate to the actual world is some kind of act of ostension, such as the pointing of a finger, by which one can *force* another's attention to be directed towards a particular object of sense. This is something of an altogether different nature from a general description or explanation. The same criticism that Peirce levels against Hegel can thus be leveled against OSR: “The capital error of Hegel which permeates his whole system in every part of it is that he almost altogether ignores the Outward Clash ... this direct consciousness of hitting and of getting hit enters into all cognition and serves to make it mean something real” (W5: 225, 1885). I will have more to say about the “direct consciousness of hitting and of getting hit” later in Chapter 5.1.

Before moving on to consider the second difficulty faced by OSR, let us examine whether the other major proponent of OSR, Steven French, offers a compelling solution to the problem of the physical/mathematical distinction. As mentioned in the Introduction, he devotes an entire chapter to the problem (which he calls the “collapse” problem) in his recent tome, *The Structure of the World*

(French 2014). In that chapter (Chapter 8), he seems to offer two distinct proposals, or rather lines of thought, as solutions to the collapse problem. One of these involves the introduction of a non-structural element to differentiate between the “abstract” and the “concrete.” French is clear that the introduction of such an element in no way infringes upon the central tenet of OSR, provided that the non-structural element is not an individual:

It is no part of OSR or of other members of the structuralist tendency in general that all terms, concepts, features, elements, or whatever have to be *defined in* or *reduced to* structuralist terms. The core feature of OSR, we recall, concerns the structuralist reduction of and, according to one form, elimination of objects and such a feature and its associated claims is certainly compatible with further non-structural features and their associated claims. (French 2014: 201)

What French specifically has in mind seems to be “trope theory” and “mereological bundle theory” (French 2014: 197), both of which he discusses at length in Chapter 7.7 (French 2014: 183–89). Here, it should be noted that French’s discussion of these theories is only part of his survey of metaphysical “tools” that the OSRist can utilize, and that he does not commit himself to either theory. Nonetheless, it will be worthwhile to point out why these theories are inadequate as solutions to the collapse problem, because by doing so we will be able to get a sense of what an adequate solution should look like.

Let us examine trope theory first. A *trope* is “a particular instance of a property, such as Springsteen’s awesomeness” (French 2014: 184). The advantage of appealing to tropes is that it allows us to reduce both particular objects and general properties to “bundles” of tropes, thus resulting in a parsimonious ontology (French 2014: 184). The “bundling” is formulated in terms of a primitive relation of “compresence” or “togetherness” (which, French points out, may have to be replaced or supplemented by another notion so as to avoid clashing with physics; French 2014: 184–85). What

French calls “network instance realism” is simply an expansion of trope theory from monadic predicates (properties) to n -adic predicates (relations), resulting in an ontology of individuated relations (French 2014: 186).

The problem with this approach is that it introduces the notion of *instance* as a primitive notion (in its definition of a trope as a “particular instance” of a property) without explaining what *instantiation* is, which was the heart of the issue to begin with. It then goes on to “explain” general properties as “bundles” of tropes; but since a trope was introduced as a “particular instance of a property,” all we have done is go around in circles. In other words, this purported solution blatantly begs the question. An adequate solution to the problem of the physical/mathematical distinction should provide us with general principles, whose validity is demonstrated by independent means, which would make the notion of *instantiation* (and the associated notions of existence, general/particular, etc.) intelligible by deriving it as a necessary consequence of the operation of those principles. This is the kind of explanation that we expect—nay demand—of a theory as fundamental as OSR. Neither trope theory nor network instance theory are adequate in this sense.

“Mereological Bundle Theory” (MBT) fares no better than this. This theory, like trope theory, conceives of the world in terms of a one-category ontology of properties, where “objects” are understood as bundles of these (French 2014: 187). But instead of appealing to the notion of “com-presence” to bundle the properties together, it invokes the notion of mereological “fusion.” That is, it conceives of properties as “parts” of objects in the same sense as spatiotemporal parts, and attempts to explain objects as “fusions” of these parts. Since according to MBT the properties to be fused are not tropes but general properties, the OSRist who appeals to this theory must somehow explain how a fusion of these properties can result in a *particular* object rather than a general object-concept. French’s idea seems to be to appeal to spatiotemporal location, which is itself under-

stood as one of the properties to be fused to create an object (French 2014: 187). Thus we can reduce particular objects to “fusions” of general properties, including spatiotemporal location.

The problem with appealing to spatiotemporal location to explain the notion of instantiation is that, as pointed out by Ladyman and Ross (ETMG: 172), recent studies in quantum gravity give us good reason to suspect that the macroscopic four-dimensional spacetime that we are familiar with is dynamically emergent rather than fundamental—the limiting behavior of a more fundamental process or structure such as spin networks (loop quantum gravity), stochastic causality relations (causal set theory), and quantum entanglement (tensor network approaches). Even string theorists seem to have accepted that background-independence (in the sense of being independent of a background spacetime structure) is a desideratum for an adequate theory of quantum gravity (ETMG: 169). Surely, a theory that aspires to be as fundamental as OSR does should not presuppose a God-given backdrop of spacetime, given that some of the most promising research programs in contemporary fundamental physics give us good reason to think that spacetime is not a fundamental aspect of reality. An adequate solution to the problem of the physical/mathematical distinction ought to make instantiation *entail* spatiotemporal determination, rather than simply equate the two.

The second line of thought that can be discerned in French’s chapter on the collapse problem—and perhaps the more significant of the two, since French seems to commit himself to it—is the idea that the “structure of the world” itself is “concrete” rather than “abstract.”

Putting things in broad terms, the ‘quantum structure’, say, does not exist independently of any exemplifying concrete system, it *is* the concrete system ... Indeed, the central claim of OSR is that what appears to be a system of objects and relations should be reconceptualized as a relational structure; that is, it is the structure that is (ultimately) ontically prior and also concrete. Hence, the conception of structure as abstract is rejected also. (French 2014: 209)

Mathematical structure can then be understood as the result of abstracting away certain features of the concrete, physical structure of the world—it is “surplus” structure, in the sense that there is more of it than there is physical structure (French 2014: 197–98, *et passim*).

While it is not altogether clear what French means by “abstract” and “concrete,” his use of expressions such as “exist independently of any exemplifying concrete system” to characterize abstractness suggests that he is using the term “abstract” in the sense of *general* or *multiply instantiable*, and the term “concrete” in the sense of *actual* or present *here and now* (a more detailed discussion of these notions will be given in Chapter 4.1). If indeed this is what French has in mind, that is, if French’s claim is that structures are not general, then my contention will be that this betrays a serious confusion as to the mode of being of structures on French’s part. A structure must by its very nature be general, because it is precisely its multiple instantiability that makes it a structure rather than an individual; and that which is multiply instantiable is what philosophers have traditionally called *general* (or *universal*). To borrow an example that Peirce gives in “Prolegomena to an Apology for Pragmaticism” (CP 4.530, 1906), consider the molecular structure of a certain substance. When a chemist conducts experiments on a sample of this substance in order to determine its molecular structure, he is not interested in that particular sample. After the experiment is done, he may as well throw it away. What the chemist is interested in is the *molecular structure as such*, considered independently of its particular instantiations; and anything that can be considered independently of its particular instantiations is, by definition, general or “abstract.” For the chemist, the particular sample is nothing more than a sign of the general molecular structure: the chemist sees the general structure *through* the sample, in much the same way that one grasps an idea through the mediation of a written or spoken word. This is not to put forth any particular theory about the ontological status of general structures, namely whether they are somehow “in” each instantiation or have being independent of their instantiations, etc. My point is simply that the instantiation itself is

not the general structure, and that the latter is the proper object of scientific investigation. Furthermore, it should be emphasized that the fact that a general structure is instantiated here and now (as is the molecular structure in a particular sample) does not thereby make it non-general, since it is its multiple *instantiability* that makes it a general rather than an individual.

Revealingly, right after the above quotation, French goes on to remark that taking structures to be “non-specific, general, and *ontological* ... would be to accept a contradiction in terms” (French 2014: 209, emphasis in original).¹⁸ Now why would it be a “contradiction in terms” to affirm that structures are both general and ontological (that is, real)? The only explanation seems to be that French is a nominalist, assuming without argument that generals cannot be real. That is, he is assuming that whatever is real must also be actual, and since he wants physical structures to be real, he has no choice but to insist that they are actual—and *this* is a contradiction in terms, tantamount to asserting the existence of something like a “particular general.” Substantially the same criticism has been voiced by Stathis Psillos: “To put the point crudely, French seems to require a conception of structure which renders structures both concrete (qua particular spatiotemporal physical systems) and abstract (qua shareable by distinct physical systems)” (Psillos 2012: 171); however it should be noted that I do not concur with Psillos’s characterization of the actual or “concrete” in terms of spatiotemporal determination.¹⁹

It is true that at one point, French grants the possibility that some form of “structure as abstract” version of OSR is viable (French 2014: 209). However, he immediately qualifies this by remarking

¹⁸ More accurately, he is paraphrasing Slowik (2012: 53), but he seems to accept the claim.

¹⁹ In the latter half of this paper, Psillos goes into a discussion of the problem of universals, taking up the concept of *structural universals* and examining whether it could help the OSRist. His answer—with which I substantially agree—is negative. My aim in the ensuing chapters is to present as an alternative the Peircean view, which does not maintain that structures are a particular kind of universal (as in the theory of structural universals), but that *all universals are at bottom structural*.

that this kind of OSR “brings serious problems in its wake, most notably to do with the lack of causal efficacy of this kind of structure” (French 2014: 209). But why would an “abstract” structure lack causal efficacy? It is by no means evident that this must be the case. Although French goes into a long discussion of causation in the latter half of Chapter 8 of his book (French 2014: 212–28), he does not seem to offer any explanation of why this should be the case. Again, I think the assumption here is that “abstract” structures cannot be causally efficacious because *they are not real*—they are mere figments of the mind, or something to that effect. This nominalistic identification of *reality* with *actuality* is, I believe, the central flaw of French’s version of OSR. Although Ladyman and Ross’s OSR is subtler than French’s, by virtue of its reliance on Dennett’s theory of real patterns, we shall presently see that it is plagued by the same problem.

1. 4. 2 Problem 2: The Concept of Representation

Let us turn to the second of the difficulties faced by OSR, that it cannot give an adequate account of the relationship between the world and our representations of the world. The question, it will be recalled, is: what is it that OSR is asserting the reality of? Is it the mathematical or formal structures embodied in our theories, or the extra-representational structure of the world itself, represented by those theories? Ladyman and Ross seem to endorse the latter view, which is not surprising, given their commitment to scientific realism, albeit of a structuralist kind. If they were to hold the former view, that it is the mathematical or formal structures embodied in our theories that are real, apparently there would have to be something *outside* of those theories, so to speak, that makes those theories *true* rather than false; and as realists, Ladyman and Ross are committed to the idea that our current best scientific theories are true (or approximately true) in some sense. But what can this “outside” be, other than the structure of the world in itself? Thus Ladyman and Ross are led naturally to the latter view, that it is the structure of the world in itself—or the “world-structure” as they call it, as we saw earlier in a quotation (ETMG: 158)—that is real.

Ladyman and Ross seem to endorse the notion of truth as some kind of correspondence between our theories or representations on the hand and the world in itself on the other. Call this the *correspondence conception of truth*. Here, I am not trying to articulate any precise account of this conception. Indeed, my claim will be that this conception is problematic precisely because it is vague. However, its being vague does not prevent it from being a real pattern that manifests itself in various forms throughout ETMG. Most significantly, it is implicit in the fact that the authors feel they have to respond to Laudan's argument against realism from theory change (the so-called Pessimistic Meta-Induction; ETMG: 83–93) and to van Fraassen's constructive empiricism (ETMG: 95–111). Laudan and van Fraassen's arguments, as well as Ladyman and Ross's responses, make sense only if one presupposes the correspondence conception of truth, that there is such a thing as the "world in itself" and that truth consists in our representations accurately "copying" or "mirroring" it; and indeed it is no exaggeration to say that the entire scientific realism debate in analytic philosophy of science is predicated upon the assumption, often tacit, that one form or another of the correspondence conception must be correct. The correspondence conception of truth can also be discerned in Ladyman and Ross's distinction between the "formal" and "material" modes discourse (ETMG: 118–22), and in their distinction between "representational" and "extra-representational" real patterns (ETMG: 243); the latter will be discussed in more detail below.

Now, as I noted above, the problem with the correspondence conception of truth is that the crucial notion of "correspondence" is left unarticulated. What does it mean to say that a representation "corresponds" to the world in itself? What do we mean by the "world in itself" in the first place? How can we verify whether a given representation corresponds to the "world in itself," given that we have no way of accessing the latter? An analogy from mathematics will serve to illustrate this problem. Consider the set $\{0, 90, 180, 270\}$ together with the binary operation of addition modulo 360. This represents rotation by 90 degrees on a plane. Next consider the set of complex numbers

$\{1, i, -1, -i\}$ together with the binary operation of multiplication. This too represents rotation by 90 degrees on a plane. Both of these structures satisfy the group axioms, and are isomorphic to each other. Now two isomorphic groups are said to be *representations* of the same *abstract group structure*; in the above example the abstract group structure is known as the cyclic group of order 4. The question is: are the isomorphic representations also isomorphic to the abstract group structure? Evidently the answer is no: in order to say that a representation is isomorphic to the abstract group structure, we must define a one-to-one mapping between the elements of both in such a way that the group operations are preserved; but it is impossible to specify the elements of the abstract group structure because it does not consist of distinct, identifiable elements at all (which is precisely why we say that it is “abstract”). This is strictly parallel to the situation in the correspondence conception of truth: namely, it is impossible to define a correspondence relation between our representations on the one hand and the “world-structure” on the other because the latter cannot be an actually existing thing; rather, if there is such a thing, it must be regarded as “abstract” or general, and whatever is “abstract” or general cannot consist of distinct, identifiable elements (the reason for this will become clear in Chapters 4 and 5). Once again, we see that that the root of the problem lies in the confusion of *real* with *actual*—a confusion characteristic of nominalism.

Another problem with Ladyman and Ross’s appeal to the “world-structure” is that, as we saw in Chapter 1.2, the very being of a pattern is dependent on an actual or potential observer. As Dennett had pointed out (1991: 32), a pattern, by definition, must be a candidate for pattern *recognition*; and this necessarily implies that there is someone or something that does the recognizing. What meaning, then, can we attach to a notion like “world-structure,” if this is understood as the structure of the world as it is *in itself*, independently of any observer? It is true that Ladyman and Ross are careful to point out, in their discussion of what they call “first-order” and “second-order” real patterns, that they are not making the metaphysical claim that there are two *kinds* of real patterns (ETMG:

242). Rather, their first-order/second-order distinction is meant to capture contingent relationships among real patterns: second-order real patterns are real patterns that “depend for their genesis and maintenance on their utility to observers as devices for tracking other real patterns” (ETMG: 243). When there is such a genetic dependence between two real patterns, R1 and R2, such that the existence of R2 depends on its utility to observers for tracking R1, R2 is said to be “second-order” with respect to R1. Then, a real pattern is said to be “extra-representational” if it is not second-order with respect to any other real pattern; otherwise it is “representational” (ETMG: 243).

Despite Ladyman and Ross’s careful proviso that they are not making a metaphysical distinction between two kinds of real patterns, I find the notion of extra-representational real patterns problematic. As we saw in the previous section, Ladyman and Ross define the reality of patterns in terms of projectibility. To say that a pattern is projectible is to say that it can be reliably used by observers to track other real patterns (namely, those that have not yet been observed). Now if there is such a thing as an extra-representational real pattern, that is, a real pattern that can exist independently of its utility to observers for tracking other real patterns, then how can its reality be established? Not in terms of its projectibility. As mentioned above, I think that here Ladyman and Ross are sliding into a correspondence conception of truth. Furthermore, by definition, an extra-representational pattern would seem to be capable of existing independently of reference to any actual or potential observer. How does this cohere with Dennett’s claim that a pattern must be a candidate for pattern recognition? Insofar as Ladyman and Ross incorporate the observer-dependence of patterns into their definition of real patterns (Chapter 1.3), there seems to be a serious tension within their system. If we are to retain talk of “extra-representational” patterns or the “world-structure,” the notions must be reformulated in such a way as to render them compatible with the observer-dependence of patterns;

and moreover, we should dispense with the idea that any intelligibility can be attached to such a notion as the structure of the world as it is in itself.²⁰

Without further ado, let us turn to Peirce to see how his ideas can shed light on these issues faced by OSR. Reciprocally, we shall also see how OSR can serve as a frame of reference that will allow us to see an aspect of Peirce's philosophy which, I believe, has not been sufficiently emphasized in the literature, namely its *structuralist* aspect.

²⁰ Here, it is unnecessary to go into French's views with respect to the problem of representation. As I mentioned above (fn. 17), the notion of "world-structure" is due not to Ladyman and Ross but rather to Ladyman and French. In light of this, and given what has already been said regarding French's version of OSR, I believe it is clear that my criticism of Ladyman and Ross with respect to the second problem applies equally, if not *a fortiori*, to French.

2. Pragmatism as a Structuralist Theory of Meaning

2.1 Two Formulations of Pragmatism

A good place to start our foray into Peirce's system of thought is his pragmatism. I will first outline the basic idea behind Peirce's pragmatic maxim by distinguishing between two distinct formulations of the maxim, which I call the *verificationist formulation* and *practicalist formulation*, and by discussing their relationship. Then, in the following section, I will show how pragmatism can be understood as a structuralist theory of meaning.

Peirce's pragmatic maxim appeared in public form for the first time in "How to Make Our Ideas Clear" (1878), the second paper of the *Illustrations of the Logic of Science* series, published in the *Popular Science Monthly*. It was formulated as a logical principle for clarifying ideas, for attaining the "third grade of clearness" of apprehension, the first two being the traditional criteria of *clearness* and *distinctness* as formulated by Descartes and developed by Leibniz (W3: 257–61). The famous statement of the maxim runs as follows: "Consider what effects, which might conceivably have practical bearings, we conceive the object of our conception to have. Then, our conception of these effects is the whole of our conception of the object" (W3: 266). While it is evident that this is a rule for clarifying our concepts in terms of some sort of "effects," the difficulty of making sense of this statement lies in understanding what Peirce means by "effects which might conceivably have practical bearings." The natural interpretation, induced by the examples that Peirce gives in the paper as applications of the pragmatic maxim, is this: the maxim is a rule which tells us to clarify our concepts in terms of what we conceive would be the counteractive effects of actions conducted upon an object to which the concept in question can be veritably applied as a predicate. In other words it dictates that the meaning of a concept can be expressed in conditional propositions of the form:

(i) If you were to do m to object x (to which the concept in question can be veritably applied as a predicate), then you would have an experience of type n .

Call this the *verificationist formulation* of the pragmatic maxim.²¹ The examples that Peirce gives in “How to Make Our Ideas Clear” in order to illustrate his maxim, namely those of the concept of “hardness,” “heaviness,” “force,” and “reality,” fit neatly with this interpretation. In the case of hardness, the pragmatic maxim dictates that the meaning of calling something (say a diamond) “hard” can be expressed in conditional propositions such as: “if you were to apply pressure to the diamond with a knife-edge, then it would not be scratched.” Likewise, the meaning of calling something “heavy” can be expressed in conditional propositions such as “if you were to try to lift the heavy object, then it would take considerable effort.” Peirce’s clarification of the concept of “reality” is conducted along similar lines: he asks what the “peculiar sensible effects which things partaking of it [the quality of reality] produce” (W3: 271).

There are passages, however, that suggest a different interpretation of the pragmatic maxim. “How to Make Our Ideas Clear” can for the most part be read along verificationist lines, but there is one passage which does not seem to fit this interpretation. This is where Peirce takes up the concept

²¹ This corresponds to what Alston calls the *experimentalist* formulation, which he expresses by the following scheme: “If you do m to x , then you will experience n ” (1955: 67–68). My formulation is a correction of Alston’s in two respects: firstly, instead of saying “experience n ,” I say “experience of *type* n ,” in order to indicate that the experience should be a general type rather than a particular instance (the significance of this will become apparent in Chapters 4 and 5); and secondly, I have replaced Alston’s “you *will* experience” with the subjunctive “you *would* have an experience.” The difference between “will” and “would” is subtle but important. It concerns the reality of *possibilia*, the recognition of which prompted Peirce to abandon his earlier Scotist brand of realism and adopt a more “extreme” form of realism in the late 1890s. Significant though the distinction may be, I will not go into it in this thesis; for a more extended discussion of this matter see Aames (2015, online text).

of “force,” and says “According to our rule, we must begin by asking what is the immediate use of thinking about force” (W3: 268). Here he is talking not about how the subject of our predication will behave under given conditions, but the practical effects of our having the conception of force. This seems to imply that the meaning of the concept of “force” should be clarified not in terms of conceivable sensible effects, but in terms of the bearings which the concept will have on our *conduct*. It should be noted, however, that Peirce’s actual application of the pragmatic maxim to the concept of force is conducted along verificationist lines, this initial remark notwithstanding. I will return to the concept of force in the following section.

There are passages from other writings, mainly from the later period of Peirce’s life, that reinforce this reading. In the 1905 paper “The Issues of Pragmaticism,” Peirce gives a reformulation of his pragmatic maxim as follows:

The entire intellectual purport of any symbol consists in the total of all general modes of rational conduct which, conditionally upon all the possible different circumstances and desires, would ensue upon the acceptance of the symbol. (EP2: 346, 1905)

Here, explicit reference to “effects” is dropped, and the meaning of a symbol (of which the concept is a species) is instead equated with “general modes of rational conduct.” Again, in the Harvard Lectures of 1903 Peirce says:

Pragmatism is the principle that every theoretical judgment expressible in a sentence in the indicative mood is a confused form of thought whose only meaning, if it has any, lies in its tendency to enforce a corresponding practical maxim expressible as a conditional sentence having its apodosis in the imperative mood. (EP2: 134–135, 1903)

The idea behind these formulations can be rendered in the following way. The meaning of a concept can be clarified in terms of *habits of conduct* expressible in conditional propositions of the form:

(ii) If you want to have an experience of type r , then you ought to do s to object x (to which the concept in question can be veritably applied as a predicate).

Call this the *practicalist formulation* of the pragmatic maxim.²² Again, to take the concept of hardness for example, a practicalist clarification would look something like this: the meaning of calling something—take the diamond again—“hard” consists in habits of conduct expressible in conditional propositions such as “if you want to see the diamond resisting being scratched, then you ought to apply pressure to it with a knife-edge.” The idea is that the meaning of a concept lies in the attitudes that we take towards objects to which we can veritably apply the concept as a predicate.

Sentences rendered in formulation (i) can always be translated into those of formulation (ii), by taking experience type n as the object of desire, and action m as the action one is obligated to on the condition of having the desire, that is, by substituting m for s and n for r .²³ But the converse does not hold. In order to see why the converse does not hold, it is necessary to retrace Peirce’s derivation of the maxim in “How to Make Our Ideas Clear.” First he observes that the “soul and meaning of thought ... can never be made to direct itself toward anything but the production of belief.

²² This formulation is taken in all essentials from Alston’s formulation of the same name: “if you want r , then you ought to do s to x ” (1955: 68). There are two differences between my formulation and Alston’s: I have added that the experience r should be a general type, and I have made it explicit that the meaning of the concept lies not in the conditional statement as such, but rather in the *habits of conduct* expressible in such statements. The significance of these modifications will become clearer in Chapters 4 and 5.

²³ Again, this way of putting the matter is borrowed from Alston (1955: 68). Hookway (2012) offers a similar account of Peirce’s various formulations of the pragmatic maxim, although he gives three distinct formulations instead of two.

Thought in action has for its only possible motive the attainment of thought at rest; and whatever does not refer to belief is no part of the thought itself” (W3: 263). So the meaning of a thought can be explicated by reference to the belief which it leads to. Next he notes, following his argument in “The Fixation of Belief,” that a belief is simply another name for a habit, a tendency to act in certain ways given the relevant circumstances. Thus we attain the practicalist formulation of the pragmatic maxim, as we have explicated the meaning of a thought in terms of belief, and belief in terms of habit.

But the further move from habit to action, and action to sensible effects, requires two additional assumptions. Since a habit is a rule for action, what a habit is depends on when and how it causes us to act (W3: 265). We can thus explicate habit in terms of action, provided that action is understood as *virtual* and not actual—actions that *would* be executed given the relevant circumstances, even if those circumstances are never actually realized—lest we fall into a nominalist interpretation of pragmatism. And since, according to Peirce, the purpose of every action is to produce some sensible result (W3: 265), we can conduct the final move from action to sensible effects. We can thus see that the verificationist formulation requires two further assumptions than the practicalist formulation, and this is the reason why propositions in the former can be translated into those of the latter but not vice versa.

From this it may be argued, as Alston (1955) does, that the practicalist formulation is more fundamental than the verificationist, the latter being a special case of the former. If, however, we grant Peirce’s assumption that there is no habit which is not a tendency towards action, and no action which does not aim at some sensible result, then we may legitimately speak of the pragmatic maxim as though it were equivalent to the verificationist formulation, even though the practicalist formulation may be more fundamental. The rationale for this is that almost all of Peirce’s actual applications of the maxim take the form of the verificationist formulation, most likely because taking into

account all of the possible different circumstances and desires in which a conception may be involved is highly impractical. Even if the practicalist formulation may be more fundamental in theory, in practice it is almost always the verificationist formulation that is employed. Therefore, in the ensuing discussion I shall drop reference to the practicalist formulation and speak of the pragmatic maxim in terms of the verificationist formulation, unless otherwise specified. It should be stressed, however, that in speaking of sensible results, we shall understand *virtual* sensible results—what *would* occur given the relevant conditions, even if those conditions are never actually realized—rather than the sensible results of any actual instance.

2.2 Pragmatism as a Structuralist Theory of Meaning

In order to illustrate what I mean when I say that pragmatism is a structuralist theory of meaning, let us first take up Peirce’s application of the pragmatic maxim to the concept of “force” in the third section of “How to Make Our Ideas Clear” (W3: 268–71). There he gives a detailed explanation of vector composition, but I do not think this has much relevance to his main point.²⁴ What is essential here is what the concept of force stands for, and Peirce’s answer is that its meaning is entirely captured in the relation $\mathbf{F} = m\mathbf{a}$, where \mathbf{F} is force, m is mass of a body, and \mathbf{a} is acceleration. \mathbf{F} and \mathbf{a} are vectors.

Intuitively, this equation, Newton’s Second Law of Motion, denotes a causal relation: if you were to apply force \mathbf{F} to a body of mass m , then the body would accelerate at an acceleration of \mathbf{a} . An acceleration is any change in velocity, and as such it is a sensible effect. Conversely, any body

²⁴ The reason why he gives such an explanation is most likely because the use of vectors in classical mechanics was not yet conventional at the time of writing (1878). The standard notation at the time was the quaternion notation developed by Sir William Hamilton and Peter Tait. It was not until J. Willard Gibbs introduced the methods of vector analysis in his lectures at Yale University in the 1880s that the vector notation became standard in classical mechanics (Yukawa 1975: 58–62).

whose velocity is changing must be under the influence of some force. Peirce's point is that the meaning of the concept of force is fully captured by this relation, $F = ma$. In conjunction with other laws for determining the force exerted on a given body in a given system, we can predict how the body will accelerate. But the concept of force itself has no reference other than to this acceleration. I just said that the equation of motion denotes a causal relation, but whether we say that force *causes* acceleration, or force *is* acceleration (of a body of mass m), is merely a verbal issue.²⁵ All that we have a right to say is that F is such a thing which stands in such and such a relation to m and a . The meaning of the concept of force is entirely determined by the relational structure in which it figures; there is no such thing as a mysterious force-like entity over and above this relational structure.

Now force is a general concept. To say that the meaning of general concepts is determined by the relational structure in which they figure is clearly not enough to establish that particular objects are not real, as claimed by OSR. Even if force is nothing but acceleration, apparently there must be *something* that is accelerating. We are thus led to the notion of an individual, of which properties and relations may be predicated. While this may seem to be a straightforward notion, let us examine it in more detail. When I perceive a particular object in front of me, say a table for example, and I perceive it *as* a table, I am making the perceptual judgment "this is a table" by categorizing the "this" in front of me under the general concept of a table. Without that general concept, I cannot cognize the thing in front of me *as* a table. The same goes for any other perceptual judgment, such as "this is brown" or "this is rectangular." Without recourse to general concepts which function as predicates, I cannot cognize the particular thing in front of me at all. Now, if the meaning of a general concept

²⁵ As I pointed out in the previous section, here we should be careful not to reduce force to *actual* acceleration, since otherwise we would have to say that a body at rest and under the influence of two equal forces of opposite direction is not under the influence of any force, because it is not actually accelerating. Rather we should say that force is *virtual* acceleration: if one of the forces were removed, then the body *would* accelerate in the direction opposite of that force.

can be analyzed into a network of conceivable sense effects, then what I am seeing when I see a particular object in front of me, to which the general concept can be veritably applied as a predicate, must be nothing other than that web of relations which constitute the meaning of that general concept.

I contend that this is a direct consequence of Peirce's theory of the categories, as set forth in his 1867 "On a New List of Categories" (W2, Sel. 4). I shall discuss the categories in detail in the following chapter; here, as a propaedeutic, let us consider the logical process that leads us to formulate concepts in the first place.²⁶ For the sake of illustration, our discussion will be predicated upon reference to the nervous system, but it should be emphasized that the process itself is independent of its physical implementation—the nervous system is only a perspicuous instance of a process that is governed by principles that make the pragmatic maxim applicable to it. Let us start from the postulate that the nervous system can be characterized as a classificatory apparatus. By this I mean that it can be adequately modeled as a machine or program that apportions sensory stimuli to distinct classes. Initially, the nervous system classifies objects according to the effects which they have on the organism. Suppose that I see two beakers of liquid in front of me: one is water and the other is hydrochloric acid. If we restrict our discussion to the sense modality of vision, then I shall classify the two liquids as the same substance, as there are no differences in the effects which the two liquids have on my sensory receptors. The nervous system thus establishes a classificatory order of

²⁶ The following illustration is inspired by the general framework of Friedrich A. Hayek's theory of cognition, as developed in *The Sensory Order* (Hayek 1952). My example of the hydrochloric acid and aluminum is an elaboration of an example that Hayek gives in Chapter 8 of his book: "Several chemical substances may, e.g., be completely indistinguishable to the senses so long as they remain in their given state. The reason why chemistry classifies them as different substances is that in certain circumstances and in combination with certain other substances they will 'react' differently" (Hayek 1952, 8.22).

things, a mental map of the objects in its surrounding environment, according to the effects which those objects have on the organism. Call this mental map the *sensory order*.

Now suppose that I conduct an experiment on the two liquids. I drop a piece of aluminum into each of the two beakers, and observe that a reaction takes place in one—the aluminum dissolves and emits a transparent gas which, upon being brought into contact with a burning match, makes a POP sound—but not the other. I thereby modify my initial classification; I classify the two liquids as different substances. What has taken place here is that I have re-classified the objects in front of me according to the effects which they have *in relation to other objects*, in this case the piece of aluminum. The aluminum thus plays the role of a differentiating agent, with reference to which I can see the difference between water and hydrochloric acid. Gradually, such re-classification will lead to the construction of a new mental map of the environment, based on the reciprocal relations that hold between things, rather than on the relations which hold between a thing and the organism. Call this new mental map the *physical order*. Science may be understood as that process by which the sensory order is gradually replaced by the physical order, and knowledge thereby detached from idiosyncrasies of the sensory apparatus of the organism. And this is precisely what the principle of pragmatism (understood in terms of the verificationist formulation) tells us to do: it tells us to clarify our conception of objects in terms of the conceivable effects which they have in relation to other objects. That is, it tells us to retrace the steps that led us to formulate that concept in the first place. The conception can then be seen as a symbol that welds together, as it were, those relations into the unity of an idea.

Consider, for example, Peirce's pragmatic clarification of lithium, from the third section of his "A Syllabus of Certain Topics of Logic," composed to accompany his 1903 Lowell Lectures:

If you look into a textbook of chemistry for a definition of *lithium*, you may be told that it is that element whose atomic weight is 7 very nearly. But if the author has a

more logical mind he will tell you that if you search among minerals that are vitreous, translucent, grey or white, very hard, brittle, and insoluble, for one which imparts a crimson tinge to an unluminous flame, this mineral being triturated with lime or witherite rats-bane, and then fused, can be partly dissolved in muriatic acid; and if this solution be evaporated, and the residue be extracted with sulphuric acid, and duly purified, it can be converted by ordinary methods into a chloride, which being obtained in the solid state, fused, and electrolyzed with half a dozen powerful cells, will yield a globule of a pinkish silvery metal that will float on gasolene; and the material of *that* is a specimen of lithium. (EP2: 286, 1903)

Here we can see that the meaning of the general concept of lithium is determined entirely by the relations which it enters with other objects (and phenomena). To point at something and call it “lithium” is merely to specify a node within the network of relations of which the concept “lithium” is a symbolic unification.²⁷ Indeed, as we shall see in the following chapter, for Peirce this is precisely what it means to *explain* something, to render the *this* in front of me intelligible: *it is to put it into relation with other things already known so that it has a place within an order*. It is true that Peirce mentions properties such as “vitreous” and “translucent” in the above definition of lithium. But the perception of such properties themselves involves predication and hence concepts; and these concepts can be further clarified, via the pragmatic maxim, as being a system of relations. Every moment of our waking (and sleeping) hours we are perceiving and thinking relations, and it is the

²⁷ Of course, this way of putting the matter still involves reference to a “something” of which judgments are made. This “something” corresponds to what Locke called the notion of *pure substance in general*, as opposed to *ideas of particular sorts of substances*. Regarding the former he writes: “The idea then we have, to which we give the general name substance, being nothing, but the supposed, but unknown support of those qualities, we find existing, which we imagine cannot subsist, *sine re substante*, without something to support them, we call that support substantia; which, according to the true import of the word, is in plain English, *standing under* or *upholding*” (Locke [1689] 1975, Bk. II, Chap. XXIII, Sec. 2). We shall return to this issue in Chapter 5.

principle of pragmatism that explicates the structural nature of our concepts by retracing their logical genesis.

3. Peirce's Theory of the Categories

3.1. On a New List of Categories: General Outline

In order to appreciate the depth of Peirce's pragmatism, we cannot avoid delving into his theory of the categories. My aim in this chapter is twofold: first, to exhibit the operation of the three categories, Firstness, Secondness, and Thirdness, within the thought process and show how this operation manifests itself in the structuralism of the pragmatic maxim; and second, to show how the theory of categories can lead us to a conception of *representation* that does not fall prey to the second of the difficulties faced by OSR. We will be going into dense discussions, particularly with respect to interpretive issues concerning Peirce's notion of Reference to a Correlate; I beg the reader's patience, as I believe these discussions have more than a merely scholarly interest.

While Peirce's categories developed significantly over the course of his life, the best place to start is where it all began: Peirce's early studies, which culminated in his 1867 "On a New List of Categories" (W2, Sel. 4). It is here that we find the *basso continuo* that can be heard running through Peirce's thought, changeless throughout his entire life.²⁸ I will first give a general outline

²⁸ Contra T. L. Short, who claims: "Contrary to the importance so often accorded to it, the 'New List' is a stepping stone, not a keystone. Furthermore, it was a stepping stone for Peirce, not for us. It is not required for mastery of his later thought" (2007: 32). Here, it should be emphasized that Peirce himself repeatedly says, in his later years as well as his earlier years, that the *New List* is his greatest achievement: "the theory of categories ... is (if anything is) the gift I make to the world. That is my child. In it I shall live when oblivion has me—my body" (W2: 1, 1867); "on May 14, 1867... I produced my one contribution to philosophy in the 'New List of Categories'" (CP 8.213, letter draft to Mario Calderoni, c.1905); "There is mighty little in the C. S. Peirce of 1905 of identity with the C. S. Peirce of 1867. I feel entitled to speak of him as quite another person. But my opinion is that the paper On a New List of Categories is one of the most perfect gems of all philosophy. I have not been able to find any positive error in it. There is a good deal that was not then worked out, but the leading features were made out correctly." (L 224: 73, August 1905 letter to William James). I am unable to resist the suspicion that there is something method-

of the issue that Peirce is grappling with in the paper, and then I will discuss his derivation of the categories, addressing along the way the different interpretations of Peirce's notion of *Reference to a Correlate* that have been proposed in the scholarship. As will become clear, Peirce's notion of *Correlate* is of prime importance in understanding the structuralism embodied in his pragmatism.

Let us begin with the question of what Peirce means by a *category*. Following Kant, Peirce uses the term *category* to denote a *universal conception* (W2: 49), *universal* in the sense that it is at work in any process of thought whatsoever, including perception (supposing that perception involves an act of judgment, and that judgment is a thought process).²⁹ A *conception* is a logical entity having the form of a predicate, whose function is to “reduce the manifold of sensuous impressions to unity” (W2: 49), and whose validity consists in “the impossibility of reducing the content of consciousness to unity without the introduction of it” (W2: 49). Peirce's aim in the *New List* is to find these universal conceptions, and thereby explicate the logical structure of the thought process at its most fundamental level.³⁰

Here, it is important to emphasize what the *New List* is *not* intended to be. It is not a psychological investigation but a *logical* investigation; and Peirce was strenuously opposed to all forms of psychologism—the position that the study of logic ought to be grounded in a study of the human mind—from the first moment he spoke publicly on logic, in 1865, until the end of his life.³¹ The

ologically absurd in dismissing Peirce's testimonies about his own thought.

²⁹ In Lecture IX of his 1866 Lowell Lectures, Peirce explains his use of the term *universal* in this context: “Of the numerous conceptions of the mind, some apply only to certain special collections of impressions and are called particular. Others apply to all collections of impressions and are called universal” (W1: 473).

³⁰ Later, Peirce will drop the idea that the categories are *concepts*, and instead suggest that they are rather “moods or tones of thought” (EP1: 247, 1887–88). Later still, he will come to describe them as “not concepts but merely *elements* of concepts—what *fluorine* was among chemical substances until Moissan isolated it. Or better like *ions*” (L 387b: 328, 1908).

³¹ Peirce opened the first lecture of his 1865 Harvard Lectures with a critique of psychologism

New List is concerned with the logical structure of the *thought process as such*, irrespective of where or how that thought takes place. Accordingly, the argument of the *New List* is crafted in such a way that its results do not depend on contingencies such as the constitution of the human mind; for otherwise the universal validity of its conclusions would be infringed. It is true that Peirce uses terms such as “consciousness,” “sensuous impressions,” and “mental separation” that suggest a dependence on psychology. However, the offending terms are immaterial to the argument and may be eliminated if desired. Later, starting in the mid-1880s, Peirce will expand his categories ontologically, arguing that they are the fundamental elements not only of human thought but of the universe itself. This “ontological turn” is exemplified in the title of one of his essays from 1885: “One, Two, Three: Fundamental Categories of Thought and of Nature” (W5, Sel. 35). While the Peirce of 1867 was not thinking of the categories in such ontological terms, it is important to keep in mind that the ontological reinterpretation was made possible by the anti-psychologist approach of the *New List*.

Peirce derives five categories (not three) in the *New List*: Being, Quality (Reference to a Ground), Relation (Reference to a Correlate), Representation (Reference to an Interpretant), and Substance. The three categories intermediate between Being and Substance are called *accidents* (W2: 55); later, Peirce will drop Being and Substance from the list of categories, resulting in a list of three categories. These correspond to what he will eventually come to call *Firstness*, *Secondness*, and *Thirdness*—Quality corresponding to Firstness, Relation to Secondness, and Representation to Thirdness. Let us begin with the categories of Substance and Being.

For Peirce, any act of thought can be analyzed as an act of predication, that is, the act of attaching a mark to an object of attention. The “object of attention” need not be an external thing (*external* in the sense of its manifestation being uncontrollable); it can also be a feeling or preceding thought. However, in all of these cases the act of thought consists in the attaching of a conception as a logical

(W1: 163–65).

predicate to the object of attention as a subject; and in this sense there is no essential difference between them. The predicate need not be a monadic predicate (a predicate with only one “blank”). Before his long 1870 memoir on the logic of relations, “Description of a Notation for the Logic of Relatives” (W2, Sel. 39), and even before obtaining a copy of Augustus De Morgan’s memoir on the logic of relatives (De Morgan 1864) in 1868, Peirce had devoted some study to relational terms and their role in arguments.³² As early as 1865, Peirce was aware of the incompleteness of the traditional syllogistic and of George Boole’s algebra of classes (Michael 1974). We can see Peirce’s interest in the logic of relations around this time in §15 of the *New List*, where he gives the following proposition in an example: “Whatever is the half of anything is less than that of which it is the half” (W2: 58). As pointed out by Ishida (2014: 138), this kind of proposition cannot be handled within the limitations of Kant’s traditional or Aristotelean syllogistic. Although his formal treatment of relations is not as elaborate as it is in his later works, already at this stage we can see Peirce experimenting with propositions and arguments that go beyond the limits of the traditional logic. We therefore have no reason for restricting Peirce’s notion of predication in the *New List* to monadic predicates: Peirce did not intend such a restriction, nor does the argument itself turn upon such a restriction.

The “object of attention” mentioned above constitutes the first category, Substance. Peirce describes it variously as “the manifold of sensuous impressions” (W2: 49), “*the present, in general*” (W2: 49, emphasis in original), the “IT in general” (W2: 49), and “the general recognition of what is contained in attention” (W2; 49). It is the *this* in front of me, before anything has been thought about *what* or *how* it is. Peirce calls this first category “Substance” because it can only function as a

³² See Michael (1974) for a discussion of Peirce’s early studies in the logic of relations, between 1865 and 1867. Merrill (1978) carries the study further, examining the developments between 1867 and 1870, leading up to Peirce’s “Description of a Notation for the Logic of Relatives.”

logical subject and never as a predicate, coinciding with Aristotle's definition of οὐσία.³³ The reader may find it strange that Peirce characterizes Substance as a *conception*, despite the fact that it cannot function as a logical predicate. One way to understand this is to highlight Peirce's use of the word "general" in his characterizations of Substance: "the present *in general*," the "IT *in general*," "the *general* recognition of what is contained in attention," etc. Perhaps this means that although Substance cannot function as a logical predicate, there is already an incipient generality in it, or an *intrinsic connexity*, as De Tienne (1996: 167) calls it. I will not go into interpretational issues regarding the notion of Substance in this paper, since it will have little bearing on our main topic. Suffice it to say that whatever Peirce may have meant by Substance, there is no way for us to actually experience or perceive it as a bare and undifferentiated *this*. We can only conceive of it *post facto*, as a hypothetical entity or situation that serves as the starting point of the thought process, after the process has run its course. That Peirce himself understood it so is evinced by the fact that he starts his derivation of the categories from Being rather than Substance, despite his characterization of Substance as the universal conception that is "nearest to sense" (W2: 49): we have no choice but to start from Being because we do not have perceptual access to Substance.

Substance, then, is the starting point of the thought process. It is a question mark, the soliciting of an inquiry. At the end of the thought process is Being. It is that which completes the reduction of the manifold of sensuous impressions to the "unity of a proposition" (W2: 49). The end point of the thought process must be a proposition because it is the result of attaching a predicate to a subject. The rationale for calling this category "Being" is that it is "that which is implied in the copula"

³³ Aristotle, *Categories*, 2a13. The last sentence of §3 of the *New List* is an allusion to this passage of Aristotle's *Categories*: "This *it* is thus neither predicated of a subject, nor in a subject, and accordingly is identical with the conception of substance" (W2: 49).

(W2: 49). It is, so to speak, the period that seals the inquiry initiated by the question mark of Substance, rendering the object of attention intelligible.

We therefore have the starting point and end point of the thought process, Substance and Being. The three categories intermediate between these two terminals are, in order of passing from Being to Substance: Quality (Reference to a Ground), Relation (Reference to a Correlate), and Representation (Reference to an Interpretant). Notice that the order is *from Being to Substance* rather than *from Substance to Being*. This is because, as mentioned above, we have no perceptual access to Substance. The derivation of the categories must start from Being, the end point of the thought process, because that is where we always find ourselves.

The method that Peirce adopts in the *New List* is to start from Being and proceed one step at a time, searching for a conception that would occasion, and, at the same time, justify the introduction of the conception that precedes it (in order of passing from Being to Substance). Peirce writes that it is empirical psychology that furnishes the data from which we are to seek the conceptions that will be candidates for the categories (W2: 51). Now this may seem to contradict Peirce's anti-psychologism. It could be argued that there is no contradiction, as long as the argument only makes use of psychological facts as data and does not appeal to them as principles. Yet, Peirce himself will later make the following comment in his Logic Notebook: "It may be doubted whether it was philosophical to rest this matter on empirical psychology. The question is extremely difficult" (W2: 94, 1868). Here I will not go into the issue; I will simply note that later in his life, Peirce will make the search for the categories rely not on the data of empirical psychology but on the data furnished by the science of *phenomenology* or *phaneroscopy*.

Whether a given conception is the sought for category is to be verified according to whether the preceding conception can be *prescinded* from it but not vice versa. *Prescision* is a mode of conceptual distinction that involves attending to one element to the neglect of another (W2: 50). Or as

Peirce puts it in a later text, it “consists in supposing a state of things in which one element is present without the other, the one being logically possible without the other” (EP2: 270, 1903). What distinguishes prescision from other modes of distinction is that it is not always reciprocal: there are cases in which A can be prescinded from B but not vice versa. For example, space can be prescinded from color but color cannot be prescinded from space; and color can be prescinded from red but red cannot be prescinded from color (W2: 51). Such non-reciprocal cases can be explained only by the circumstance that the prescindable conception is a necessary condition for the possibility of cognizing the conception from which it can be prescinded; whereas once the prescindable conception has been introduced, the conception that occasioned its introduction may in general be neglected (W2: 51). Thus, the manifold of sensuous impressions being united under the conception of space is a necessary condition for its being united under the conception of color (and hence color cannot be prescinded from space), but once the conception of space has been introduced, the color of the manifold may in general be neglected (and hence space can be prescinded from color). In other words, if we are able to show that a certain conception A can be prescinded from another conception B but not vice versa, we have thereby shown that B cannot be reduced to unity without the introduction of A. Now, as we saw earlier, the validity of a conception consists in “the impossibility of reducing the content of consciousness to unity without the introduction of it” (W2: 49). Therefore, if A can be prescinded from B but not vice versa, this means that B justifies the introduction of A. The introduction of a category must be justified in this sense, for otherwise it would be a superfluous conception, which would in turn make it non-universal and hence not a category. Thus, if we are able to find a conception, B, such that another conception which we have already established as a category, A, can be prescinded from it, then B must be the justification for the introduction of A. This does not prove conclusively that B is also a category, since there may be other conceptions that also occasion and justify the introduction of A. But if there are such conceptions, once

they are found they may be verified using the same method: if a conception does not satisfy the criterion of prescindability with respect to the concepts adjacent to it within the order leading from Being to Substance, then it is thereby disqualified as a category. Peirce's derivation of the categories in the *New List* is thus not a *transcendental deduction* à la Kant, but rather an *inductive* investigation.

The first category that Peirce finds, in order of passing from Being to Substance, is Quality, or Reference to a Ground. A *Ground* is a hypostatic abstraction that serves as the basis for a predication.³⁴ For example, in the predicative judgment "this stove is black," *blackness* is the Ground, since it is the blackness embodied in the stove that justifies and serves as the basis of that judgment. It is by referring to such a Ground that we are able to attach a Quality to Substance and thereby produce a proposition. As Peirce puts it in an early draft of the *New List*, "Character is the ground of being; whatever is, is by being *somehow*" (W1: 352). Reference to a Ground is what occasions and justifies the introduction of Being, making it the first category in order of passing from Being to Substance. I will have more to say about Reference to a Ground after discussing the next category.

3.2 Reference to a Correlate

The next category that Peirce finds, in order of passing from Being to Substance, is Relation, or Reference to a Correlate. The section in which Peirce discusses this category in the *New List* is brief and unhelpful:

Empirical psychology has established the fact that we can know a quality only by means of its contrast with or similarity to another. By contrast and agreement a thing is referred to a correlate, if this term may be used in a wider sense than usual.

The occasion of the introduction of the conception of reference to a ground is the

³⁴ A *hypostatic abstraction* is a logical operation that turns "predicates from being signs that we think or think *through*, into being subjects thought of. We thus think of the thought-sign itself, making it the object of another thought-sign" (CP 4.549, 1906). For example, the transformation of "honey is sweet" into "honey possesses sweetness" is a hypostatic abstraction. Hereinafter, I will use the term to refer to both the operation itself and the result of such an operation.

reference to a correlate, and this is, therefore, the next conception in order. (W2: 53)

In an earlier draft, Peirce writes that “A correlate is a second substance with which the first is in comparison” (W1: 524). This and other clues have led De Tienne to suggest that “the correlate is the subject of a past experience which has already undergone predication” (1996: 297). That is, it is the comparison of the yet unknown case at hand, which Peirce calls the *Relate*, with the subject of a case already known from past experience, the *Correlate*, that justifies referring the *Relate* to the same (or similar or contrasting) *Ground* as that of the *Correlate*, and thereby attributing to it the same *Quality*.

The trouble in interpreting what Peirce means by a *Correlate* arises from the fact that he seems to be using the term in two different senses: firstly, in the sense suggested by De Tienne, as that which occasions and justifies the reference of the *Relate* to a *Ground* by serving as a precedent; and secondly, as the second term of a (dyadic or triadic) relation, the first term being the *Relate*. Peirce’s use of the term *Correlate* in the second sense occurs, among other places, in §9 of the *New List*, where he gives the dyadic relation of “murder” as an example to illustrate the notion of *representation*:

Again, suppose we think of a murderer as being in relation to a murdered person; in this case we conceive the act of the murder, and in this conception it is represented that corresponding to every murderer (as well as to every murder) there is a murdered person; and thus we resort again to a mediating representation which represents the relate as standing for a correlate with which the mediating representation is itself in relation. (W2: 53)

Here, the murderer is regarded as the Relate, and the murdered person the Correlate. De Tienne argues that Peirce was confused about the nature of the Correlate, confounding two incompatible senses of the term:

Included in the conception of reference to a correlate is that of a reference to a treasure of past experiences—a stock of representations already carried out. Where does this reference appear in the relationship of the murderer to his victim? If the former is the relate, and the latter the correlate, we obviously cannot say that the reference to the victim is a reference to a past representation ... But how can the interpretant put the murderer and victim into correlation if it cannot refer to an earlier representation, in which this correlation has already taken place? I think the main difference between “the stove is black” and “the murderer kills his victim” consists only in the number of subjects involved in the predicate, and that such a circumstance should not influence the general representation of the process as such. In other words, it should be possible to present in both cases a formally identical process. Thus, if the attribution of “black” to the stove is the function of a reference to a correlate that also underwent (or experienced) this attribution, this should also be the case with the attribution of the murder relationship between the murderer and his victim. (De Tienne 1996: 297)

Thus, in the case of the murder relation, the Correlate should be neither the murderer nor the murdered person, but past instances in which one has witnessed a murder. By comparing the yet unknown case at hand with past instances of the murder relation, one is able to refer the case at hand to the same Ground as that which successfully made sense of those past instances.

This interpretation rests upon the assumption that by a *Quality* Peirce meant not only monadic predicates but also polyadic ones (predicates with two or more “blanks”). For otherwise there would be no reason to compare a Relate consisting of two or more subjects with a Correlate likewise consisting of two or more subjects, as in the case of the murder relation. In other words, this interpretation takes, in the murder example, the dyadic relation “____ murders ____” to be the Quality to be

attached to the Relate (consisting of two subjects). However, this is not how Peirce understood the notion of *Quality*. In an attempt at a fourth installment of his *Monist Pragmaticism* series—a manuscript that bears the title “The Bed-Rock Beneath Pragmaticism”—he writes (in the context of his definition of logic as the science that studies the application of symbols to objects):

Yet in the paper in which I first put forward and defended this definition of Logic [“On a New List of Categories”] ... I noticed but one interpretation of an ordinary proposition, its Subject being taken as denoting the Object of the proposition, this being considered as a Symbol, while the Predicate signifies that *non-relative character* (which I called the “ground”) which the proposition informatively attributes to that Object ... (MS 300: 64–65, 1908; emphasis mine)

Here, Peirce explicitly states that the Ground is a *non-relative character*. Again, in a 1908 letter draft to Francis C. Russell, he writes: “My ‘ground,’—is a *univalent* element of thought, to use a chemical term ...” (L 387b: 328, emphasis in original). The Quality which consists in a reference to this Ground, therefore, must have the form of a monadic predicate.

There is a further problem with De Tienne’s interpretation of Peirce’s notion of the *Correlate*. Namely, it cuts the categories away from Peirce’s logic of relations, and, in particular, his *Reduction Theorem*, which states that all relations of adicity four or higher can be reduced to a combination of triadic relations, while triadic relations cannot be further reduced to dyadic and monadic ones, nor dyadic ones to monadic ones.³⁵ If the Correlate is regarded not as the second term of a relation but as different instances of the relation, then Peirce’s Reduction Theorem, as well as his logic of relations in general, loses its applicability to the categories and hence its metaphysical significance.

³⁵ See Burch (1991) for a proof of the Reduction Theorem, and Burch (1997a, 1997b) for a concise introduction to the proof. Burch’s proof relies on a logic system that he calls PAL (for “Peircean Algebraic Logic”), an algebraic logic that encodes the syntax of the Alpha and Beta parts of Peirce’s Existential Graphs.

This is certainly not a direction that Peirce himself intended to take, nor is it a philosophically fruitful one.

How, then, should the notion of *Correlate* be understood? Firstly, there is the issue of whether a Correlate is a form, or a determinate thing or event. Ransdell (1966: 86) argues that Peirce intended the Correlate to be a *form*—a quality, essence, or “firstness”—different from the Quality constituted by Reference to a Ground. De Tienne objects to this: “If the correlate is a form or quality, then the relate should be of such nature as well. But Peirce always speaks of the relate as substance-subject, that is to say, as that of which the form is yet indeterminate” (1996: 287). As Ishida (2009: 52) rightly points out, however, there is no reason why the Correlate should have the same mode of being as the Relate. There is no inconsistency in supposing that the Relate is a substance-subject, while the Correlate is a quality.

Furthermore, if we regard the Correlate as always being a substance-subject—or in other words a determinate thing or event rather than a form or quality—a problem arises when we try to map Peirce’s terminology in the *New List* to his later writings on semiotic, the study of signs. As we shall see in the following section, for Peirce a relation of prime importance is the triadic relation of *representation*. In general, when we say that X represents Y to Z, this means that Z is somehow able to see Y *through* X. Here, X is the Relate, Y is the Correlate, and Z is the Interpretant (which we shall turn to in the next section). To use an example that Peirce gives at the end of §9 of the *New List*, when a person sees the direction of the wind through a weathercock, the weathercock (Relate) represents the direction of the wind (Correlate) to the general conception of weathercocks in the person’s mind (Interpretant); or in other words, the person sees the direction of the wind *through* the weathercock. Peirce is here clearly thinking of the Correlate as equivalent to what he will later come to call the *object* of a sign, that which a sign stands for and serves to convey knowledge about. But the problem is this: is the object of a sign always a determinate thing or event? It is sufficient to

think of, say, a mathematical formula to realize that this is not so. Clearly, a mathematical formula does not represent any determinate thing or event; if it represents anything, it must be a general relational form. Hence, if we are to understand the notion of *Correlate* to be synonymous with Peirce's later notion of the *object* of a sign (and Peirce's examples at the end of §9 of the *New List* give us grounds for doing so), then we should reject the idea that the Correlate is always a determinate thing or event—it may be so in some cases, but not always.³⁶

The second issue that we must address is: how do we reconcile the two senses in which Peirce seems to use the term *Correlate*, namely the sense in which it occasions and justifies the attribution of a Quality to the object of attention by serving as a past instance of a similar or contrasting quality; and the sense in which it is the second term of a relation? Let us consider a passage from an 1865 manuscript, in which Peirce discusses themes that will later make it into the *New List*. After taking up the proposition “this is blue,” and arguing that the Correlate in this predication is anything *non-blue* which serves as a contrasting agent, he takes up the example of a man killing a deer:

[E]verything is such as it is in comparison with something else ... the effect of this ancient maxim is that ‘blue’ means ‘blue in comparison to’ and therefore requires a suffering object [correlate]. The transitive verb supplies this comparison [more ex-

³⁶ It is true that there are places where Peirce himself says that the Correlate should be understood as a determinate occurrence: “What I call there [in the *New List*] a ‘correlate’ is an ordinary experiential correlate, reference to which is forced upon the mind. We may call it an occurrence,’ meaning a *thing* or *fact*, single and definite” (L 387b: 329, 1908). My interpretation is that here Peirce is speaking of *genuine* or *pure* Secondness; this does not rule out the possibility of there being degenerate kinds of Secondness, where the Correlate is not a determinate occurrence. This interpretation is corroborated by a claim that Peirce makes in the third of his 1903 Harvard Lectures: “In pure secondness, the reacting correlates are, as I showed in the last lecture, *Singulars*, and as such are *Individuals*, not capable of further division” (EP2: 161). The implication is that in impure (or degenerate) Secondness, the correlates (that is, the Relate and Correlate) need not be singular or individual. Unfortunately, although Peirce says “as I showed in the last lecture,” no textual evidence survives that indicates what Peirce may have said in the second lecture.

plicity]. If a man kills a deer, that in comparison to which he is a killer is the deer. No other comparison is *needed* ... There is undoubtedly a philosophical distinction between a transitive and an intransitive verb; but the latter is nothing but that species of the former which allows its object [the correlate] most readily to be dropped—which amounts to supplying its place by an indefinite pronoun. He murders something and he is a murderer are the same. (W1: 336)

Recall that the Ground of a predication is a *hypostatic abstraction*. In the case of the proposition “a man kills a deer,” it is the character *killing-ness*, which is a non-relative character. Consequently, the Quality which consists in a reference to this Ground is also a *monadic predicate*, not a dyadic one (note that the Ground *killing-ness* is neither monadic, dyadic, nor triadic; the Ground is a hypostatic abstraction, and a hypostatic abstraction does not have the form of a predicate). Peirce’s later concept of *continuous predicates* will serve to clarify this point. His explanation of continuous predicates in a 14 December 1908 letter to Victoria Lady Welby is worth quoting in full:

When we have analyzed a proposition so as to throw into the subject everything that can be removed from the predicate, all that it remains for the predicate to represent is the form of connection between the different subjects as expressed in the propositional form. What I mean by “everything that can be removed from the predicate” is best explained by giving an example of something not so removable. But first take something removable. “Cain kills Abel.” Here the predicate appears as “___ kills ___.” But we can remove killing from the predicate and make the latter “___ stands in the relation ___ to ___.” Suppose we attempt to remove more from the predicate and put the last into the form “___ exercises the function of relate of the relation ___ to ___” and then putting the function of relate to the relation into another subject leave as predicate “___ exercises ___ in respect to ___ to ___.” But this “exercises” expresses “exercises the function.” Nay more, it expresses “exercises the function of relate,” so that we find that though we may put this into a separate subject, it continues in the predicate just the same. Stating this in another form, to say that ‘A is in the relation R to B’ is to say that A is in a certain relation to R. Let us separate this out thus: “A is in the relation R^1 (where R^1 is the relation of a relate to the relation of which it is the relate,) to R to B.” But A

is here said to be in a certain relation to the relation R^1 . So that we can express the same fact by saying “A is in the relation R^2 to the relation R^1 to the relation R to B,” and so on *ad infinitum*. A predicate which can thus be analyzed into parts all homogeneous with the whole I call a *continuous predicate*. It is very important in logical analysis, because a continuous predicate obviously cannot be a compound except of continuous predicates, and thus when we have carried analysis so far as to leave only a continuous predicate, we have carried it to its ultimate elements. (SS: 71–72)

To put it bluntly, the adicity of a predicate is inessential from a logical point of view, because any predicate can be analyzed into a triadic relation or combination of triadic relations, by transforming the “quality” involved in the predicate into a substantive via hypostatic abstraction. We are thus able to exhibit the *pure form* of the predicate, with everything inessential (so far as the logical form is concerned) thrown into the subjects. What is left is only the form of *connection* between the things that the proposition containing that predicate is about. Although the quality is left as a subject in the

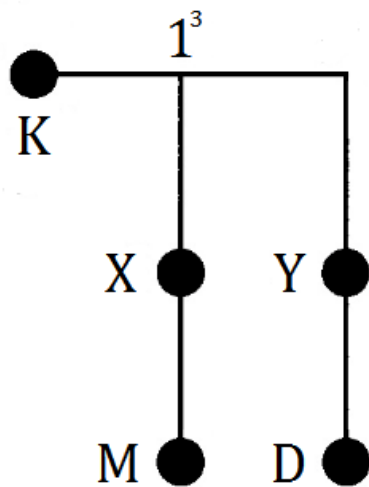

above analysis, we can further treat it as a monadic predicate attached to an indefinite individual. Thus, “a man kills a deer” can be analyzed into “a man is in the relation of killing to a deer,” which can be further analyzed into “there is an x , y , and z such that x is a killing, y exercises the function of Relate with respect to x , and z exercises the function of Correlate with respect to x .” This last proposition can be represented graphically as in the figure above. K stands for the monadic predicate “___ is a killing,” X stands for the dyadic predicate “___ exercises the function of Relate with respect to ___,” Y stands for the dyadic predicate and “___ exercises the function of Correlate with respect to ___,”

M stands for the monadic predicate “____ is a man,” and D stands for the monadic predicate “____ is a deer.” The lines represent existential quantification. Note the presence of the *teridentity* term, which, following Burch (1991), I will denote as 1^3 . This is a triadic relation that states that “____ is identical to ____ and ____,” and is always present whenever a proposition is analyzed into its pure form, that is, into a proposition containing a continuous predicate. My reason for bringing the *teridentity* term to the reader’s attention is to point out that even in a dyadic relation such as “a man kills a deer,” there is hidden triadic relation. The implications of this fact will become clear in the following section, where we turn to the third category.

Let us to return to Peirce’s 1865 passage. Although Peirce did not have the notion of continuous predicates at this stage, he seems to be thinking along the same lines in this passage (which is not surprising, considering that the central idea of continuous predicates was already implicit in Peirce’s early discussions on the leading principle of inferences; see Bellucci 2013: 192–94). Thus, the transformation of “a man kills a deer” into “a man is a murderer” involves substantivizing the murder relation and saying that “a man exercises the function of Relate with respect to the act of murder,” as represented by the left half of the above figure. If we then erase D and Y—that is, if we “drop” the Reference to a Correlate—then we are left with the monadic predication “a man is a murderer.” Note, however, that we cannot *prescind* the Reference to the Ground *killingness* from Reference to the Correlate “deer” in this example—dropping the Reference to a Correlate *alters* the predication; and this is precisely what makes the relation of “killing” a dyadic relation (W2: 55). But the fact that, by dropping (not *prescinding from*) the Reference to the Correlate, the initial predication (“a man kills a deer”) can be altered into a monadic predication (“a man is a murderer”) that refers to the same Ground as that of the initial predication, shows that the *Quality* of killing, which consists in a Reference to that invariant Ground, is indeed monadic.³⁷

³⁷ Against this it may be objected that Peirce speaks of a “relative quality” in §14 of the *New List*,

An inductive examination of similar instances will show that any judgment involving a polyadic predicate can be turned into a judgment involving only a monadic predicate, without altering the Quality attributed by the judgment to the object of attention. The procedure involves two steps: first, we transform the Quality embodied in the polyadic predicate into a non-relative character via hypostatic abstraction (this non-relative character being the *Ground* of the judgment); and second, we “drop” the Reference to the Correlate (and Reference to the Interpretant) without altering the Ground that the judgment refers to, though this will alter the judgment itself. From this it follows that the Quality involved in a judgment must always be monadic, regardless of the adicity of the predicate attributed by the judgment to the object of attention.

Hypostatic abstraction plays a crucial role in the above procedure, and I am tempted to think that this is the reason why Peirce speaks of the Ground as a hypostatic abstraction in the *New List*. Furthermore, the view that Quality is always monadic fits neatly with the overall scheme of Peirce’s list of categories: Quality is monadic, Relation (in the sense used in the *New List*) is dyadic, and Representation is triadic. It would be strange, to say the least, if Relation were dyadic, Representation triadic, and Quality a general n -adic predicate. Hence, we should dispense with the idea that the Correlate is the a past instance of a judgment involving a Quality similar or contrasting to the one ap-

as a Quality that cannot be prescindend from Reference to a Correlate. However, it is in no way evident that a relative quality in this sense should have the form of a dyadic predicate. The Quality of *killing*, for example, is a relative quality because it cannot be prescindend from Reference to a Correlate, not because it is a dyadic predicate. Indeed, if one were to hold that the Quality of killing is a dyadic predicate, then the Correlate of the predication “a man kills a deer” cannot be the deer, since upon this theory both the man and deer must be the Relate, and the Relate cannot be its own Correlate except in special cases; instead, the Correlate must be a past instance of the killing relation (or a collection thereof). But then §14 of the *New List* will make no sense: if the Correlate is understood as a past instance (or collection of past instances) of the killing relation, then *any* Quality whatsoever can be prescindend from Reference to such a Correlate, and there would be no way of distinguishing between relative and internal (non-relative) qualities.

plicable to the case at hand. It may be so in the case of a judgment involving a monadic predicate, but given that Quality is always monadic, this cannot be generalized to hold for polyadic predications; and even in the case of monadic predications, we have no reason to suppose that this is universally so. In the case of the monadic predication “this is blue,” for example, the Correlate does not have to be a blue or non-blue thing (or collection of blue and/or non-blue things) that one has witnessed in the past—the background with which the subject of predication is in contrast may also be a Correlate. However, it should be emphasized that no matter what the Correlate may be, the process of predication will always have the same logical form, according to our interpretation.

Still, it may be asked, how does a Correlate occasion and justify the attribution of a Quality to the Relate, if it is regarded as the second term of a relation? A hint towards answering this question can be found in Peirce’s 1894 rewriting of the *New List* (MS 403), originally intended as Chapter 1 of a projected book entitled *The Art of Reasoning*, but then turned into Chapter 1 of his complete but unpublished *How to Reason: A Critick of Arguments*. He begins his rewriting of §8, which treats the Reference to a Correlate, as follows:

The study of psychology, from which we find it convenient to borrow a few principles, shows us that we can never know, or even think, that a thing has a quality without thinking or having thought of other things partaking that quality and of still others wanting it, or at least possessing it in smaller measure. This is the natural, common-sense belief of the mass of men; and it seems to be confirmed by careful observation. There are only a few thinkers who do not accept it. This is the doctrine which ought in strictness to be called the *doctrine of the relativity of knowledge*. (MS 403: 11–12, 1894)

This would seem to confirm De Tienne’s interpretation of the Correlate, as a past instance of a thing partaking of a Quality similar or contrasting to the one to be predicated in a judgment. But the question is not whether such a thing is a Correlate; the question is whether that is the *only* kind of Cor-

relate, or, on the other hand, whether that is merely a special case. The passage that follows the above quotation is interesting:

There is a corresponding truth in regard to existence. That is to say, things can only possess qualities by virtue of their mutual interactions. This proposition may be called the doctrine of the relativity of facts. For example, a thing cannot be *hard*, except by virtue of resisting other things; and if there were but one atom in the universe, to say that atom was hard would be a phrase without meaning. Against attraction at a distance some men have urged that a thing cannot act where it is not; but what can it mean to say that a thing is in a place, except that the forces it exerts upon other things center at that place? (MS 403: 12, 1894)

Consider first the example of the quality *hard*. Peirce is here claiming that the quality of *hardness* consists in the (virtual as well as actual) reactions between the thing partaking of that quality and other things that may, for example, be scratched against it. The connection with the pragmatic maxim is evident—it is, in fact, the example that Peirce gives immediately after introducing the maxim in “How to Make Our Ideas Clear” (W3: 266–67). Furthermore, it is important to realize the context in which this discussion is taking place: namely, the rewriting of §8 of the *New List*, whose topic is the Reference to a Correlate. Peirce’s point is clearly that the other object—the object reacting with the hard object—is the Correlate of the predicative judgment “this is hard.” Here we can see how a Reference to a Correlate, where the Correlate is understood as the second term of a relation (in this case the relation of mutual resistance), can occasion and justify the attribution of a Quality to a Relate. Note that I am not claiming that the Correlate must be a correlate of the same relation as that attributed to the Relate. “A is hard” is not the same as “A resists B.” My point is simply that the affirmation “A is hard” *involves*, or *virtually contains*, the affirmation “A resists B.” Of course, a thing need not be in actual resistance with something else in order for it to be hard: the Quality of being hard can be prescind from Reference to any Correlate with which the

hard object is in the relation of resistance, and this is precisely why “_____ is hard” is a monadic predicate.

Again, recall the example of water and hydrochloric acid from the previous section. Suppose that I already know the chemical properties of hydrochloric acid. I drop a piece of aluminum into each of the liquids and observe that a reaction takes place in one but not the other. Here, the aluminum plays the role of Correlate in the predicative judgment “this is hydrochloric acid.” That is, it is the reactive relation between the object of attention with the aluminum that occasions and justifies the attribution of the Quality of being hydrochloric acid to the object of attention.

Now when we are speaking of relations, it is crucial to distinguish between relations that are actualized here and now, as in the case of the chemical reaction, and relations that have a *virtual* being, or the modality of a “would-be,” as Peirce would call it. The virtual relation that holds between hydrochloric acid and aluminum, for example, is: “if I were to drop a piece of aluminum into hydrochloric acid, then the aluminum would dissolve and emit a transparent gas, etc.” Let us call such a virtual relation a *correlation*. In order for the actual reaction to serve as an occasion and justification for the predicative judgment “this is hydrochloric acid,” there must be a correlation already established between hydrochloric acid *in general* and aluminum *in general*; and furthermore, that correlation must be replicated within *me*, the mind performing the predication (hence our assumption that I already know the chemical properties of hydrochloric acid).³⁸

What Peirce’s principle of pragmatism states is that the difference between two objects, such as water and hydrochloric acid, consists in nothing but differences in such correlations, namely correlations that dictate what practical effects would ensue conditionally upon a certain type of operation. Or, expressed in terms of the practicalist formulation, it states that the difference between two ob-

³⁸ As we shall see in the following section, this correlation-replica is the Interpretant of the predication “this is hydrochloric acid.”

jects consists in nothing but differences in such correlations as replicated in the behavioral patterns of information-sensitive agents simulating those correlations. Here we can see vividly the structuralism embodied in Peirce's pragmatism, and already implicit in his 1867 account of the categories.

The structuralism becomes even more striking when we consider Peirce's example of attraction at a distance: "what can it mean to say that a thing is in a place, except that the forces it exerts upon other things center at that place?" (MS 403: 12, 1894). The point that Peirce wants to make is clear: *the meaning of a general concept is its position within a network of correlations*. In the above example, the general concept is the dyadic predicate "P is at x," and the correlations are the propensities of bodies to accelerate relative to P. Thus the meaning of the concept "P is at x" is a function of, and only of, the configuration of these acceleration propensities. Now, since what a thing is is determined by the general concepts applicable to it, we can further say: *what a thing is is the way it is related with other things*. Peirce himself makes a statement very similar to this in a draft of "Abstracts of 8 Lectures," which he intended to deliver as part of his 1898 Cambridge Conferences Lectures: "Two bodies which act upon other bodies in precisely the same way will be the same body, for it is only their different reactions which impart to bodies their distinction" (MS 942: 43, 1898). That is, the very being of a body—what makes a given body the particular body that it is—consists in the way it reacts (or will react) with other bodies; apart from such relations, there is no such thing as an intrinsic identity or individuality that bestows upon a body its distinction from other bodies. The affinity of this statement with the central thesis of OSR is striking.

Reference to a Correlate is what occasions and justifies Reference to a Ground, making it the second category in order of passing from Being to Substance. In the following section we shall turn to Peirce's third category and draw out the implications of what we have discussed so far in the context of our main topic: what is a pattern?

3.3 Semiosis and the Flow of Information

The third category that Peirce derives in the *New List* is what he calls Reference to an Interpretant. An Interpretant (or Third, as Peirce will later also call it) is anything that is what it is by virtue of a power of bringing two things into relation. It is that “whose Being consists in active power to establish connections between different objects” (EP2: 435, 1908). Significant in this definition is the notion of *power*. In order for something to have a power of doing something, X, its function of doing X must be *inexhaustible* by any number of actual instances of doing X. A bridge, for example, cannot be an Interpretant, because it establishes a relation between two things only in *one* instance, and therefore does not possess a power.

In the hydrochloric acid example, the Interpretant is the virtual relation “if I were to drop a piece of aluminum into hydrochloric acid, then the aluminum would dissolve and emit a transparent gas, etc.,” as replicated in the mind performing the predication. By saying that this relation is *virtual*, I mean that it is not actual but has a real *power* or *virtus*, such that *if* the relevant circumstances arise, it can establish an actual relation between two objects, in this case between hydrochloric acid and aluminum. That the Interpretant is such a virtual relation agrees with Peirce’s identification of the *meaning* of a symbol with its Interpretant in his later writings (for example, EP2: 218, 1903 and 418, 1907). Since the pragmatic maxim (in the practicalist formulation) explicates the meaning of a symbol in terms of habits of conduct that would arise upon the acceptance of the symbol, the identification of the meaning of a symbol with its Interpretant would make sense only if the Interpretant too were a habit of conduct, expressible in the form of a conditional proposition.³⁹

³⁹ Against this it may be objected that this holds only for the Final Interpretant (or Logical Interpretant) and does not hold for the Immediate or Dynamical Interpretant (or Emotional or Energetic Interpretant) in Peirce’s late division of Interpretants (here I will not go into the issue of how the Immediate/Dynamical/Final division is related to the Emotional/Energetic/Logical division). In reply, I am inclined to say that the Immediate and Dynamical Interpretants (or Emotional

Reference to an Interpretant is the third category in order of passing from Being to Substance, because it is what occasions and justifies the Reference to a Correlate.

As an interesting side note, let us rephrase the Interpretant in the hydrochloric acid example as follows: “if this liquid were hydrochloric acid, then dropping a piece of aluminum into it would result in the dissolution of the aluminum and the emission of a transparent gas, etc.” The Correlate, it will be recalled, is the aluminum that is reacting with the (yet unknown) liquid; and the Ground is the character *hydrochloric-acid-ness*, reference to which constitutes the Quality to be attributed to the liquid. Note how the transition from Reference to an Interpretant to Reference to a Correlate, and then to Reference to a Ground has the form of an abductive inference:

If A, then B

B

Therefore A

This is in agreement with Peirce’s claim that the attribution of a Quality to a Substance is *hypothetical* (W2: 52), and also with his later claim that perceptual judgments are a limiting case of abductive inferences, differing from the latter only in the degree of uncontrollability (W2: 227, 1903).

Now let us turn to Peirce’s examples in §9 of the *New List*, which deals with Reference to an Interpretant. While Peirce’s discussion in this section is couched in terms of “comparing” the Relate and the Correlate, we should be careful not to allow this psychological language to lead us into a narrow conception of the Interpretant. In order to make sense of some of Peirce’s examples, we must understand the Interpretant as anything whose being consists in the power of establishing *any*

and Energetic Interpretants) are degenerate variants of Interpretant, and therefore do not possess the characters proper to the genuine Interpretant. It must be admitted, however, that the issue needs to be worked out more fully.

kind of relation between two elements, and not just the relations of *similarity* or *contrast*, as the notion of comparison may suggest.

Peirce's first example is the "comparison" of the letters p and b:

Suppose we wish to compare the letters p and b. We may imagine one of them to be turned over on the line of writing as an axis, then laid upon the other, and finally to become transparent so that the other can be seen through it. In this way we shall form a new image which mediates between the images of the two letters, inasmuch as it represents one of them to be (when turned over) the likeness of the other. (W2: 53)

In this example, the Interpretant consists in the operation of flipping one of the letters, laying it upon the other, and then making it transparent. This is an Interpretant, insofar as it is an image that allows us to see one of the letters *through* the other, and thereby bring them into relation. It can be expressed in a conditional proposition such as: "if I were to flip one of the letters, lay it upon the other, and then make it transparent, the two letters would coincide." Consider what the situation would be like if we did not have this Interpretant. The two letters would be opposed to each other blindly; we would not be able to make any sense as to the mode of their relation. It is the Interpretant that supplies *intelligibility* to the relation by serving as a sign that *represents* that relation (hence Peirce's characterization of the third category as "Representation"). For example, let us denote the operation described above as R. Then we can express the entire relation as bRp. Without the mediating sign R, there would be no way of representing—and hence making intelligible—the relation between the letters b and p. Now if we hypostatize R and turn it into an object of thought, then we can treat it as the subject of a proposition, as in "p is in the relation R to b," making it the third term of a triadic relation (namely the relation of representation).

Thirdness, as Peirce will later call the third category, consists in none of the three terms taken separately, but in the *form of connection* between the three terms, which can be represented graphically by the teridentity term 1^3 . The Interpretant itself is not the form of connection, but a sign that explicates the teridentity term that is *implicit* in the case of relations prescindable from Reference to an Interpretant, such as the “killing” relation that we considered above (recall the graphic representation of the proposition “a man kills a deer”). We may call Thirdness the *pure power of gluing*, “pure” because it lacks any material content—whatever quality, object, or intellectual purport a representation may have is inherited from the three terms that Thirdness brings into relation.

Peirce’s second example is the murder relation that we saw above:

Again, suppose we think of a murderer as being in relation to a murdered person; in this case we conceive the act of the murder, and in this conception it is represented that corresponding to every murderer (as well as to every murder) there is a murdered person; and thus we resort again to a mediating representation which represents the relate as standing for a correlate with which the mediating representation is itself in relation. (W2: 53)

Here, the murder relation, that is, the *conception* of murder, is the Interpretant, since this is what establishes the relation between the murderer and victim. Again, if we denote the murder relation as M , the murderer as a , and the victim as b , then the relation as a whole can be expressed as aMb . If we then hypostatize M and turn it into an object of thought, then we can treat it as the subject of a proposition, such as “ a engages in a certain act M with respect to b ,” making M the third term of a triadic relation. M thereby serves two distinct functions: on the first-order level, it represents a as standing in the murder relation to b ; and on the second-order level, it presents itself as standing in the triadic relation of representation to both a and b . In the form aMb , the Interpretant M is fulfilling its first-order function, by representing a as standing in the relation of murder to b . Here, the Inter-

pretant is *invisible*, so to speak; we see *through* it without making it an object of thought. In its second-order function, on the other hand, M is itself turned into an object of thought, as in “*a* engages in a certain act M with respect to *b*.” The relation between *a* and *b* is thereby compressed into a single sign that presents itself *as* a compression of that relation.⁴⁰ Hence Peirce’s characterization of the Interpretant as a “*mediating representation which represents the relate to be a representation of the same correlate which this mediating representation itself represents*” (W2: 53, emphasis in original).

Instead of saying that the Interpretant represents (in its second-order function) the relation between Relate and Correlate, Peirce here says that it represents the *Correlate* which it represents the Relate to represent. This is likely in order to emphasize the *directionality* involved in the representation relation: we attend *from* the sign (Relate), which is present to us, *to* the object (Correlate), which, if not present, is present as a *re*-presentation. Suppose that, in the hydrochloric acid example, the aluminum is not present; that is, we have not yet dropped it into the acid. Even in the absence of the aluminum, the Interpretant *re*-presents it in its virtual relation, “if I were to drop a piece of aluminum into hydrochloric acid, then the aluminum would dissolve and emit a transparent gas, etc.” I am thereby able to see the aluminum *through* the hydrochloric acid in front of me, in the form of an

⁴⁰ Psychologically, this amounts to “catching one of the transient elements of thought upon the wing and converting it into one of the resting places of the mind” (CP 3.424, 1892), as Peirce, alluding to James’s illustration of the distinction between the “substantive parts” and “transitive parts” of consciousness in *The Principles of Psychology* (James 1890, Chap. IX, §3), puts it in his second installment of “The Critic of Arguments” series for *The Open Court*. Especially interesting in this connection is Peirce’s response to James’s suggestion to replace the term “transitive” in his notion of the “transitive parts” of consciousness with the term “relational”: “When you shoot one of our ‘transitive’ thoughts on the wing, transfix it and make it ‘substantive,’ *then* you have the idea of a relation; and until the thought ceases to be transitive it has no consciousness of the relation. While it is transitive, it is in a certain sense what you may call *relative* but it is not *relational*” (COWJ 7: 487, 28 Jan 1894).

anticipation of what *would* occur if it were dropped into the acid. In other words, the aluminum is virtually contained within my recognition of the liquid in front of me as hydrochloric acid. Don Ross, summarizing Ian Hacking's (1990) interpretation of Peirce, suggests that Peirce viewed the world as "a kind of directed graph in which the edges are statistical relations" (Ross forthcoming: 10). I think this is a very apt expression, provided that we differentiate between statistical relations that are due to mere chance and those that are manifestations of real Thirds. The graph must be *directed* rather than undirected because for Peirce, relations in general have an orientation, *from* the Relate *to* the Correlate. This does not, of course, rule out the possibility of symmetric relations. What functions as a Relate in a certain predication instance of a dyadic relation R may be the Correlate in a different predication instance of the same relation, in which case R would be a symmetric relation.

The double function of the Interpretant is what makes triadic relations so powerful: it enables a dyadic relation to be turned into an object of thought, without destroying the information encapsulated in that relation, and thereby makes it susceptible to becoming the element of another relation, and so on *ad infinitum*. In the case of the murder relation, the hypostatization of M in the form of "*a* engages in a certain act M with respect to *b*" allows M to become the Relate of a further relation, such as "M is N to P." That is, through its second-order function, the Interpretant is able to address itself as a sign to a future Interpretant, in this case N. We shall presently see an example of this, but first let us consider in more detail the concept of *information* that we have referred to repeatedly throughout this thesis; and in particular, let us consider in what the process of information "flow" consists in. My aim is to show how the Peircean conception of *representation* that we have been discussing so far offers us a viable alternative to the correspondence relation relied upon by the OSRists (see Chapter 1.4).

In the most general terms, information is correlation.⁴¹ To say that A carries information about B is equivalent to saying that there is a correlation—a virtual relation—between A and B such that an observer would be able to make predictions about B on the basis of A with a higher probability of success than in the absence of A. This is the basic idea behind the concept of *mutual information* in information theory and probability theory; the main difference being that our definition explicitly involves the notion of an *observer*.⁴² Reference to an observer is unnecessary in the case of mutual information, insofar as the observer is the scientist using the concept of mutual information—it would be redundant to incorporate into a concept reference to the user of the concept. But in order to understand the process of information “flow,” with which we are here concerned, it is essential to incorporate the notion of observer into our definition, since the same data may be interpreted as information by one observer and as noise by another. In other words, information is an essentially triadic concept—it cannot be prescind from Reference to an Interpretant.

Suppose that a man hiking in the mountains finds a footprint, and, on the basis of this footprint, infers that a bear is nearby. The footprint is the Relate, which we shall denote as A, and the bear is the Correlate, which we shall denote as B. The Interpretant that occasions and justifies the reference to a bear is the correlation between a certain type of footprint and bears, embodied in the man’s general conception of bear footprints. Let us denote this Interpretant as C. If the man’s background knowledge is adequate, that is, if he is able to supply an adequate Interpretant, then he will be able

⁴¹ Here I am not using the term *information* in the technical sense introduced by Peirce in his 1867 “Upon Logical Comprehension and Extension” (W2, Sel. 6).

⁴² The mutual information between two event systems, X and Y, is defined as the difference between the entropy of X and the entropy of X conditional upon knowledge of Y. A standard textbook covering a broad range of topics in information theory is Cover & Thomas (2006). Mutual information is introduced in Chapter 2 of this book.

to make valid predictions about B on the basis of A, such as “if I go this way, I should encounter a large, four-legged hairy mammal, etc.”

The Interpretant is at the same time that which *establishes* the correlation between A and B—thus preceding it in some sense—and a *product* of that same correlation—thus following it in another sense. In the former sense the Interpretant is fulfilling its first-order office, and in the latter its second-order office. It is in the latter sense that Peirce says in his later semiotic writings that a sign *determines* an Interpretant in such a way that the latter is thereby mediately determined by the sign’s object. This process can also be described in the following manner: *C has become “infected” by the correlation between A and B, with the result of a new correlation being established between B and C.* Suppose that the man is with his wife, and says to her: “be careful, there’s a bear around here.” The correlation between the word “bear” and the animal which that word stands for, embodied in the wife’s general conception of the word “bear,” will conjure in her mind an image of the bear, as a result of the man’s utterance. What was the Interpretant in the initial sign relation, namely the correlation in the man’s mind between the footprint and bear, has turned itself into the Relate of a different sign relation, this time with the same bear as the Correlate and the wife’s general conception of the word “bear” as the Interpretant. The wife is thereby infected by the correlation that initially held between the footprint and bear. By such a process, which we should suppose will continue virtually indefinitely, we can see how *information* about the Correlate B “flows” from one mind to another, or from one state of the same mind to another state.⁴³ This is the central insight encapsulated in Peirce’s *law of mind*, that “ideas tend to spread” (W8: 136, 1892).⁴⁴

⁴³ By “mind” I do not, of course, mean only human minds. Anything that is sensitive to information—that is, anything that is capable of simulating correlations—I shall call a *mind*.

⁴⁴ See also Peirce’s interesting example of the liquid in bottles connected by tubes, in one of his “Basis of Pragmaticism” manuscripts: “Let a community of quasi-minds consist of the liquid in a number of bottles which are in intricate connexion by tubes filled with the liquid. This liquid is of

Our discussion of information brings us back to the topic of patterns, since as we saw in Chapter 1.4, a pattern is something that in some sense carries information about other patterns. Firstly, let us consider how we can characterize a pattern within the general framework that we have developed in the current chapter. We can say that a pattern is either a general Form or the manifestation of a general Form, depending on whether one uses the term to refer to a pattern conceived independently of its particular instantiations, as when we say that the motions of charged particles near a current ring and the motions of charged particles near a magnetic dipole exhibit the same pattern, or a pattern instantiated here and now, as is anything that we perceive through our senses. Adopting Dennett's criterion for the presence of a pattern in some data, we can say that it is the compressibility of the manifold of the given that constitutes the being of a pattern; and to specify a program that may have produced some data is to give a plausible *explanation* of the data, in the same way that to specify a Form that may be applied to a subject is to give a plausible explanation of the subject. (I say *program* instead of *compression algorithm* because the latter term tends to give the impression that the data is somehow ontologically prior to the algorithm, whereas in fact the data should be regarded as a *product* of the operation of the program). Forms and programs thus fulfill the same practical function, and according to the pragmatic maxim, any two things that fulfill the same practical function ought to be regarded as identical. Hence, if by a "pattern" we mean the program governing the pro-

complex and somewhat unstable mixed chemical composition. It also has so strong a cohesion and consequent surface-tension that the contents of each bottle take on a self-determined form. Accident may cause one or another kind of decomposition to start at a point of one bottle producing a molecule of peculiar form, and this action may spread through a tube to another bottle. This new molecule will be a determination of the contents of the first bottle which will thus act upon the contents of the second bottle by continuity. The new molecule produced by decomposition may then act chemically upon the original contents or upon some molecule produced by some other kind of decomposition, and thus we shall have a determination of the contents that actively operates upon that of which it is a determination, including another determination of the same subject" (EP2: 392, 1906).

duction of the data, then we are referring to a general Form; if by a “pattern” we mean the manifestation of the program governing the production of the data, then we are referring to the manifestation of a Form. This holds regardless of whether the pattern is real or not; in a case where one has discerned an unreal pattern, one has identified a program or Form that has no real being (that is, one that cannot be projected into unobserved cases), or one that is not operative in the case at hand. Furthermore, since the pragmatic maxim tells us that the entire intellectual purport of a general Form consists in a network of correlations, a pattern too must be an embodiment of the correlations that constitute the intellectual purport of the Form which it is identical to or is a manifestation of.

Recall the way in which Ladyman and Ross defined patterns in ETMG: they defined patterns recursively, in relation to a computer simulating those patterns (Chapter 1.3). The simulation is then said to “carry information” about the pattern that it simulates. The output of that simulation is a further pattern, which can be simulated by another computer, and so on *ad infinitum*. The congruence with our description of the sign process—as illustrated in our example of the footprint and bear—is striking, but so are the differences.

While it is not altogether clear how Ladyman and Ross conceive of the relation between the *simulation* relation that they employ in their definition of real patterns and the *correspondence* relation that seems to be involved in their distinction between “representational” and “extra-representational” real patterns, as well as in their response to the argument from theory change and Van Fraassen’s constructive empiricism (Chapter 1.4), their simulation relation is, I believe, the one that harbors more philosophical potential, for two reasons: first, the simulation relation does not assume that its object is an actual existent as does the correspondence relation (recall our example of the abstract group structure in Chapter 1.4); and second, it is formalizable in information-theoretic terms, and considering that the language of information is quickly becoming the *lingua franca* of the sciences—from fundamental physics to biology, ecology, neuroscience, economics, linguistics, and soci-

ology—a philosophical concept’s formalizability in information-theoretic terms can only be a virtue. However, there is one aspect of Ladyman and Ross’s conception of simulation that I find problematic; and furthermore, it will be my contention that the Peircean representation relation outlined in this chapter can serve to rectify this problem. The key difference between the simulation relation employed by Ladyman and Ross and the Peircean representation relation is that the former is a dyadic relation, whereas the latter is triadic. The problem with relying on a dyadic relation in this context is that there will be no guarantee that all of the simulations carry information about the same object; whereas in the Peircean model, the Reference to a Correlate is preserved across the replication of correlations.

In order to illustrate what I mean, and to give a concrete example of how the triadic model works in the case of a non-actual object, let us return to our earlier example of the footprint and bear. There, the Correlate was a determinate existent, namely a bear (or rather we should say *partially* determinate, since all that the hiker can say is that *some* bear created the footprint). Let us replace this Correlate with an indeterminate Form, such as the general molecular structure that we considered in Chapter 1.4. Here, the particular sample of the substance is the Relate or sign *through* which we see the general molecular structure. When a chemist is able to determine the molecular structure of this sample, his conception of the substance is thereby infected by the correlation between the sample and general structure. In the terminology of Ladyman and Ross, we can say that the chemist’s conception becomes a simulation of the same structure of which the sample was a sign. If the chemist writes down the chemical formula of the substance he has determined, then that formula—the output of the simulation—will be infected by the initial correlation. The sample and the formula thus function as *representations* of the same general molecular structure, in much the same way that $\{0, 90, 180, 270\}$ together with addition modulo 360 and $\{1, i, -1, -i\}$ together with multiplication are representations of the same abstract group structure. It is evident that if the sign rela-

tion were not triadic, there would be no guarantee that the formula is *about* the same structure as that represented by the sample; and indeed there would be no directionality or intentionality involved in the relation, these being attributes proper to Thirdness.

Given that Peirce's categories are the fundamental elements of thought, and that the theory of categories reveals the thought process to consist in the establishment and propagation of correlations, we can say that thought is thoroughly relational. How does this relate with the thesis of OSR? It may be alleged that from the thesis that thought is thoroughly relational, it does not follow that the world itself is thoroughly relational, as claimed by OSR. To argue so would be tantamount to sliding from epistemology to ontology, says the interlocutor. In the following chapter, we shall see why Peirce rejects such a distinction between epistemology and ontology, between thought and the world. For Peirce, thought is continuous with the world itself; and this continuity is what makes possible the ontological re-interpretation of the categories that was mentioned at the outset of this chapter. Furthermore, we will see how this rejection of the epistemology/ontology distinction will provide us with an answer to the second of the difficulties faced by OSR, that it cannot give an adequate account of the relationship between the world and our representations of the world.

4. Nominalism and Realism

Let us begin by noting that the Peircean model of representation (or rather our Peircean modification of Ladyman and Ross's simulation relation) outlined in the previous chapter does not presuppose that the represented object is an actual existent, as does the correspondence model of the OSRists. This will constitute the positive component of our answer towards the second difficulty faced by OSR. That is, we have seen how something, X, can represent something else, Y, without Y being an actual existent. The current chapter will constitute the negative component of our answer, that if there is such a thing as the "world-structure" as espoused by the OSRists, then it cannot be an actual existent—it must be a real *general*.

The realism of Peirce and "realism" as it is commonly understood today are entirely different philosophical positions. For Peirce, realism is opposed to all forms of *nominalism*, and not just to what we today call anti-realism, instrumentalism, or constructive empiricism (although these too can be characterized as species of nominalism). Therefore, in order to attain a proper understanding of Peirce's realism, it is first necessary to understand what nominalism is, and Peirce's arguments against it.

Before delving into the realism/nominalism debate, however, a few words on the methodology of metaphysics are in order. As we saw in Chapter 1, the advocates of OSR regard metaphysics as the work of synthesizing scientific hypotheses, at least one of which must be a hypothesis from fundamental physics; and as such, it only comes after the other sciences. Ladyman and Ross support this position by attacking the use of intuition in philosophy, at least as evidence for the truth or falsity of hypotheses, arguing that there is no reason to suppose that our intuitions about the way the world is track truth in any sense (ETMG: 10–15). I fully endorse Ladyman and Ross's attack on the evidential use of intuition in philosophy, and so would Peirce.

However, it does not follow from this that metaphysics ought to be confined to synthesizing the hypotheses of other sciences. The assumption of Ladyman and Ross's view is that science is possible without any metaphysics. Of course, science may be possible without any *metaphysicians*, but to suppose that scientific inquiry can proceed without any underlying metaphysical assumptions about the way the world is—that is a crude metaphysics indeed.

The kind of metaphysics espoused by Peirce is not one that relies on intuition as evidence for the truth or falsity of its claims, but one that is based on the observation of facts. For Peirce, metaphysics is an observational science, just like any other science (excluding mathematics, which is a *hypothetical science* in that it proceeds by freely laying down hypothetical constructions, with no regard for whether those constructions are applicable to the actual world). The only difference between metaphysics and the other observational sciences lies in the nature of the data that they rely upon:

[M]etaphysics, even bad metaphysics, really rests on observations, whether consciously or not; and the only reason that this is not universally recognized is that it rests upon kinds of phenomena with which every man's experience is so saturated that he usually pays no particular attention to them. The data of metaphysics are not less open to observation, but immeasurably more so, than the data, say, of the very highly developed science of astronomy, to make any important addition to whose observations requires an expenditure of many tens of thousands of dollars. (CP 6.2, 1897)

This does not mean, however, that there is no place for the kind of metaphysics espoused by Ladyman and Ross. The kind of metaphysics espoused by Ladyman and Ross corresponds to what Peirce would call *philosophia ultima* or *synthetic philosophy*, as opposed to *philosophia prima* or metaphysics (EP2: 372–73, 1906). The aim of synthetic philosophy is to synthesize the results of the other sciences into a unified picture of the world; and as such, it comes after the other sciences. The aim of metaphysics, on the other hand, is to provide the principles that the special sciences

(physics, biology, chemistry, psychology, economics, history, etc.) must take for granted in their investigations; and as such it comes *before* the special sciences. In Peirce's late classification of the sciences, metaphysics is based only on mathematics, phenomenology, and the normative sciences (which includes logic). Both metaphysics and synthetic philosophy are important branches of scientific inquiry, and we must be careful not to disregard one in favor of the other. In this chapter we will be engaging in metaphysics in the sense espoused by Peirce.

4.1 Introduction of Terminology and Basic Framework

Our first step should be to familiarize ourselves with the terminology and basic framework of the realism/nominalism debate. Of course, this is not the place to retrace the entire history of the debate, from Plato and Aristotle through the Middle Ages; that would be the subject of at least a book-length monograph. Neither will I be concerned so much with exegesis of Peirce's texts, as with outlining the central issue in a broadly Peircean framework, and in a way pertinent to our discussions so far in this thesis.

The traditional definition of a *general* (or *universal*) is that which is predicable of multiple occurrences, such as *horses in general* as opposed to this or that particular horse.⁴⁵ This definition should be understood to encompass relations as well as properties. I use the word "occurrence" instead of "thing" to avoid the implication that "things" are individuals in the sense defined in Chapter 1.2. This is also Peirce's preferred terminology, for the same reasons: "I like the word 'occurrence' as reminding the thinker that a *thing* is never thoroughly singular, but the only object that is so is an instantaneous event" (L 387b: 329, 1905). Whether or not something is *predicable* of multiple occurrences is independent of whether or not there really are multiple occurrences of which the general can be veritably predicated. Thus *sun* is general because as a matter of logical form it is predicable of multiple occurrences, although in reality there is only one sun. Indeed, not only can

⁴⁵ Aristotle, *De Interpretatione*, VII, 17a38.

we apply it *falsely* to many things other than the bright, fiery object in the sky, but we can also apply it truthfully to different *occurrences* of that same object (cf. EP2: 183, 1903).

Something is predicable of many occurrences if and only if it is *indeterminate* in regard to some possible property or relation, either as possessing it or not possessing it.⁴⁶ For example, *animal* is logically divisible into *vertebrate animal* and *invertebrate animal*—or in other words animality is *indeterminate* in regard to the property of being a vertebrate—and is thus general. This indeterminacy is what makes the general applicable in multiple instances, since the application of a general to a particular instance must be *hypothetical* in order for it to be informative (W2: 52); and the application can be hypothetical only if the general is conceived independently of its particular application, that is, as indeterminate. Conversely, anything that is indeterminate in some respect is general, for the same reasons.

Anything that is determinate in *all* respects we shall call an *individual*, to express the fact that it is logically indivisible.⁴⁷ This definition of individual is equivalent to our definition in Chapter 1.2, as something that can subsist independently of relation to anything else. The proof is as follows. According to the pragmatic maxim, the intellectual purport of a general consists in correlations between the potential subject of predication and other objects (that is, Correlates). Furthermore, the being of an object consists in the intellectual purport of the generals applicable to it. Therefore, anything capable of subsisting independently of relation with anything else cannot contain any element of generality in it—otherwise its being would consist in correlations with other objects—and

⁴⁶ This is the idea behind Peirce's definition of *general* as that for which the Principle of Excluded Middle does not hold: "anything is general in so far as the principle of excluded middle does not apply to it" (EP2: 351, 1905).

⁴⁷ "[T]he individual is determinate in regard to every possibility, or quality, either as possessing it or as not possessing it" (CP 1.434, 1896). See also Peirce's discussion of the "logical atom" in his 1870 "Description of a Notation for the Logic of Relatives" (CP 3.93, 1870).

thus it must be determinate in all respects. Conversely, anything that is determinate in all respects must be capable of subsisting independently of relation with anything else, because from the fact that relations are general, it follows that anything that *cannot* be conceived apart from its relation with something else (and hence cannot subsist independently of anything else) must *ipso facto* contain in it an element of generality.

It will be found convenient to distinguish between *absolute individuals* and *relative individuals* (recall our preliminary discussion of the distinction in Chapter 1.1). A relative individual is something that may be made more determinate, but is logically indivisible for the practical purpose at hand. In other words, it is individual relative to a certain grain of observational or conceptual resolution; the relevant grain of resolution being dictated by a particular purpose or inquiry. Something that is indivisible on any grain of observational or conceptual resolution we shall call an absolute individual.

In order for something to be individual, absolute or relative, it must be *actual*, or present *here and now* (in the sense to be explained below), for in no other way can every question regarding its possible properties and relations, which may conceivably be asked of it (in the case of an absolute individual) or is necessary to ask of it given a particular purpose or inquiry (in the case of a relative individual), be determinately answered. In order for something to be actual, it must be at least a relative individual, for if something is present here and now, then every question regarding its possible properties and relations that is necessary to ask of it given a particular purpose or inquiry, must in principle (even if not practically) be susceptible to a determinate answer. Thus, in the case of a horse in general, we need not be able to answer the question of whether it is black or non-black; but in the case of an actual horse, the question must be susceptible to a determinate answer. If it be objected that this does not do justice to boundary cases for which some question does not admit of a determinate answer—such as a man who is at the boundary of being bald and non-bald—the reply

is that relative to the particular purpose or inquiry in which that question is relevant, the object is not even a relative individual but is general.

The quality of being *here and now*, or *haecceity*, should not be confounded with spatiotemporal determination. It may entail spatiotemporal determination, but that is not self-evident.⁴⁸ It is simply the quality of being *this* unique occurrence rather than some other occurrence of the same kind, of being denotable by indices such as “this” or “that” or the pointing of a finger. For lack of a better expression, we may say that *haecceity* is a property, but we must keep in mind that this is only a manner of speech. Even if we decide to speak of *haecceity* as a property, we must realize that it is a property of a fundamentally different nature from other properties. The reason is that the property of being *this* unique occurrence cannot be a property common to many occurrences, for to say that different occurrences have in common the property of being unique would be to affirm a contradiction.

Realism is the doctrine that some (but not necessarily all) generals have a real being. Something is said to be *real* if and only if its being is such as it is independently of what any particular mind or collection of minds may think about it. We should be particularly careful with the notion of mind-dependency, since our entire argument for realism will turn upon it. Namely, we should be careful to distinguish between the property of being dependent or independent of *this or that particular instance of thought*, and the character of being dependent or independent of *thought in general*. Something is said to be dependent on a particular instance of thought if and only if its being is such that it is by virtue of its being thought as such. Thus, the content of a dream prescinded from its actual occurrence is *mind-dependent* in this sense of mind-dependency, since its being consists wholly in the circumstance that someone dreamt it as such; while the fact that the dream took place in the

⁴⁸ The question of whether *haecceity* entails spatiotemporal determination will not be addressed in this thesis.

way it did is *mind-independent* in this sense of mind-dependency, since that fact cannot be altered or destroyed merely by thought, no matter how many minds may think otherwise (W3: 271). On the other hand, something is said to be dependent on thought in general if and only if it is *cognizable*, that is, it is a possible object of thought. Both the content of a dream and the fact that the dream took place are *mind-dependent* in this sense of mind-dependency, since both are possible objects of thought. It should be emphasized that we shall take *real* to be synonymous with *mind-independent* in the first of the two senses of mind-dependency outlined above; this is merely a terminological stipulation and does not, if I am not mistaken, beg the question in favor of either nominalism or realism. Hereinafter, the terms “mind-dependent” and “mind-independent,” as well as cognate terms, will be used in the first of these two senses, unless otherwise specified.

Against the claim that the fact that the dream took place in the way it did is *real*, it may be urged that if every mind in the world were to think in a certain way, in this case that the dream took place in the way it did, then that would *ipso facto* constitute the fact that the dream took place in the way it did. The reply to this is that there are cases where everyone may think that such and such is the case and yet everyone is wrong—the existence of the luminiferous ether, for example. Just because every mind believes that such and such is the case at a certain stage of inquiry does not mean that further inquiry may not reveal facts that contradict those beliefs. This property of exerting an external constraint on thought is what we shall mean by *real*.

Nominalism is the doctrine that only individuals, relative or absolute, are real—generals are mere *names*, mind-dependent signs that exert no influence on existing things; hence the term *nominalism*. There is no essential difference between *conceptualism* and nominalism in the sense defined, insofar as both take generals to be mind-dependent rather than real. The distinction between *reality* and *existence* is crucial in the realism-nominalism debate. Reality is equivalent to mind-independency, whereas existence is synonymous with *actuality*. It is perfectly conceivable that something that does

not exist (is not actualized here-and-now) is nonetheless real. Whether this is not only conceivable but also really the case is the point upon which nominalism and realism dispute.

4.2 Peirce's Scholastic Realism

Perhaps the most famous of Peirce's arguments against nominalism is the one that he delivers in the fourth of his 1903 Harvard Lectures, "The Seven Systems of Metaphysics" (EP2: 179–95). There, he takes a stone in his hand and announces that he will conduct an experiment: he will let go of the stone and see whether it will fall to the floor. Of course, the experiment itself is meaningless, since everybody knows what will happen. But the deeper meaning of the experiment lies in the very fact that it is meaningless. How do we know that our expectation that the stone will fall will be fulfilled? The only intelligible answer is that the stone is governed by a real law operative in nature, *real* in the sense that it is not a mere mental formula or way of organizing the phenomena. For if the law were only a mental formula, there would be no way of explaining why future events will conform to it (and we know that they will), apart from assigning to the mind some kind of miraculous power of prognosis. If the law, however, is a real would-be, a rule dictating what *would* occur given the relevant conditions, even if those conditions are never actually realized, then witnessing the actual instantiations of the law will be no wonder.

Now as we saw in Chapter 2.1, the pragmatic maxim dictates that all generals are embodiments of laws expressible in conditional propositions of the form: "if you were to do *a* to object *x* (to which the general in question can be veritably applied as a predicate), then you would have an experience of type *b*." In the case of the stone, saying that something is a stone involves identifying the laws it conforms to, one of which can be expressed as: "if the stone were released from one's hand, then it would fall to the floor"; and the conjunction of all such conditionals constitute the entire intellectual purport of the general concept *stone*. Therefore, insofar as we know those laws to be real, then so is the general that embodies them. Thus runs Peirce's argument for realism from the

experience of anticipation.⁴⁹ Here we can see the intimate connection between Peirce's pragmatism and Scholastic realism, a connection emphasized by Peirce himself in many places throughout his writings.⁵⁰ It should also be recalled that this is essentially the same argument given by Dennett for the reality of patterns (Chapter 1.2), which is not surprising, considering that patterns are either generals or manifestations of generals. The merit of this way of arguing for realism is that it gives us a criterion for distinguishing between real and non-real generals—a criterion that the realist is obliged to provide, given that he holds that only some and not all generals are real. Namely, those generals that embody laws that we know (inductively) to be real are real generals, while those generals that we know (inductively) to not embody real laws are non-real generals.

I shall outline another one of Peirce's arguments for realism in a moment, but before that I want to return to our main topic, the difference between realism in the Peircean sense and realism as it is commonly understood today. It should be emphasized that realism in the Peircean sense is in no way opposed to *idealism*, the doctrine that only ideas are real; rather it necessarily entails a form of idealism, as we shall see below. Contemporary philosophers, particularly those working in the Anglophone tradition, often use the term *realism* to denote the doctrine that there is a reality independent of *all* thought, rather than this or that particular instance of thought, and that truth consists in a "correspondence" in some sense between our thoughts on the one hand and this external reality on the other. As we saw in Chapter 1.4, this is the way that Ladyman and Ross understand realism, and this is also the sense of realism upon which the scientific realism debate is predicated. Taken in

⁴⁹ The argument is also developed in "Hume on Miracles and Laws of Nature" (of which the first four sections out of eleven are published in EP2: 67–74, 1901), and in the fourth of his 1903 Lowell Lectures (MS 460, partly published in CP 1.15–26 but misidentified by the editors of the *Collected Papers* as part of Lecture III).

⁵⁰ For example, in a manuscript of 1906: "It is plain that pragmatism involves scholastic realism, since it makes all intellectual purport, and therefore, the meaning of reality itself, to consist in what *would be*, under conceivable conditions most of which can never be actualized" (MS 845: 26, 1906).

this sense, realism is certainly opposed to idealism. But this is really a species of nominalism, insofar as it makes the realness of ideas derive from their correspondence in some sense with an external reality, instead of being real on their own. But as Peirce put it: “*Realism*, in the proper sense of the word, sanctioned by the continual usage of nigh a thousand years, is the doctrine that *reality* and *idea* are not contrary, but that *ideas* are sometimes real ...” (MS 860: 8, 1893). Of course, this is not the place to go into an assessment of the historical accuracy of this statement.⁵¹ Significant for our purposes is Peirce’s argument to the effect that any other form of realism would be a self-contradictory doctrine. Let us turn to this argument.

The fundamental difference between the nominalist and realist lies in where they locate the real. In order to illustrate what I mean, I shall take up Peirce’s argument for realism in his 1871 review of Alexander Campbell Fraser’s *The Works of George Berkeley* (W2: 462–87). Although clothed as a book review, this article is perhaps the clearest statement of Peirce’s peculiar brand of realism in his entire oeuvre. What follows will be a condensed reconstruction of the line of thought that can be discerned in this text, reinforced by considerations developed in other earlier texts.

The nominalist holds that generals have only a mind-dependent or mental being, and are not “out there” in the world. But there must be something to constrain these ideas so that they are not arbitrary fictions. Thus the nominalist is compelled to say that there are real things outside of the mind which are the source of our ideas. Our ideas, they typically say, are derived from sensations which in turn are caused by these external objects, and are veracious insofar as they “represent” or “correspond to” these objects. There can be no element of generality in these external objects—considered in themselves they cannot have any properties or partake in any relations—since it is the assump-

⁵¹ See Chapter 2 of Boler (1963) for a discussion of the possibility of reading Duns Scotus along such lines.

tion of the nominalist theory that generals have only a mental being. The external object must therefore be absolutely individual, determinate in all respects.

Now as we saw in Chapter 3, it is only by putting things into relation with other things and thereby giving them a place within an order that we understand them. But how can an absolute individual be put into relation with something else? To put something, A, into relation with something else, B, is to make it determinate in regard to its relation with B; but this would be possible only if A is initially indeterminate in regard to that relation. It follows that an absolute individual is not susceptible of being put into relation with anything else, and hence it must be absolutely unintelligible.

But as Peirce had demonstrated in “Questions Concerning Certain Faculties Claimed for Man” (W2, Sel. 21, 1868), to posit such an unintelligible entity is self-contradictory, for to think of anything as being beyond all thought is to think it nonetheless, and therefore the conception of that thing must have the form “A, not A.” It is like trying to step outside of oneself or trying to see one’s own eye. An absolute individual is thus impossible. In order for something to have any being at all, it must be a *possible* object of thought—even if it is unknown at a certain stage of inquiry, it must *in principle* be cognizable through inquiry. Whence Peirce concludes that “*cognizability* (in its widest sense) and *being* are not merely metaphysically the same, but are synonymous terms” (W2: 208–9). The realist alternative must therefore inevitably be a kind of idealism—an *objective idealism*, to use a later expression of Peirce (EP1: 293, 1891).

What exactly is objective idealism? First Peirce observes that there is an element of arbitrariness or under-determination in all thought. This includes our sense perceptions, since all perceptions involve judgments (of the form discussed in the *New List*), and all judgments are *hypothetical* with respect to the Quality that they attribute to their object. The nominalist theory, which locates the real in the past as the cause of our sensations, therefore leads to skepticism concerning our knowledge of

the world. For there is no guarantee that our sensations “copy” the external thing exactly as it is. This in turn gives the realist a clue as to where to locate the real. Whereas the nominalist looks toward the past, the realist locates the real in the future, for it is in the future that we expect the element of arbitrariness in thought to be ultimately eliminated. Indeed, the real as cognizable must *ipso facto* be an object of indefinite inquiry.

Experience establishes that when two incomplete or inconsistent ideas collide, a process of supplementation or self-correction takes place. In other words, among ideas there is a universal tendency towards the establishment of *consistency*, regardless of whether those ideas are in one mind or multiple minds. Peirce illustrates this point using the example of a blind man and deaf man:

Suppose two men, one deaf, the other blind. One hears a man declare he means to kill another, hears the report of the pistol, and hears the victim cry; the other sees the murder done. Their sensations are affected in the highest degree with their individual peculiarities. The first information that their sensations will give them, their first inferences, will be more nearly alike, but still different; the one having, for example, the idea of a man shouting, the other of a man with a threatening aspect; but their final conclusions, the thought the remotest from sense, will be identical and free from the one-sidedness of their idiosyncrasies. (W2: 468–69)

The general tendency of rational minds to supplement each other and correct themselves ensures that for any question with a definite answer, thought in general must gravitate towards that answer given a sufficient amount of time. This answer, the *ideal limit of inquiry*, is what Peirce calls the truth, and that which is expressed in the truth is what he calls the real (W2: 470). This conception of reality is consistent with the rejection of the absolute individual, for here the real is conceived as independent of any particular instance of thought, but not of thought in general. Again, this view necessarily implies the reality of generals, for general concepts enter into all judgments, including veridical judgments.

From the standpoint of this Peircean brand of realism, the distinction between epistemology and ontology is no longer relevant. The important distinction is no longer between thought and the world as it is in itself, but between arbitrary thoughts and thoughts that resist and have persistence. It is on the basis of this realism that Peirce is able to expand his categories into cosmic principles, during the period leading up to his seminal “A Guess at the Riddle” (W6, Sels. 22–28, 1887–88). The categories are no longer confined to thought processes as we find them in human and other higher animals, but are conceived to be the fundamental principles operative in Nature itself. This is not the place to go into the details of how Peirce conceives the categories to operate in the domain of each science—psychology, physiology, biology, physics, etc. Suffice it to say that they are meta-laws, laws that govern the evolution of the laws of nature.

Now, as we saw in the previous chapter, the categories reveal thought to be thoroughly relational, consisting in the establishment and propagation of correlations. Given that the categories are the fundamental elements not only of human thought but also of the world itself, it follows that the world itself must also be thoroughly relational, in agreement with the central thesis of OSR.

However, it is important that we also see the crucial difference between this Peircean brand of structuralism and OSR. Insofar as OSR takes reality to consist of structures rather than individual objects, we may say that it is realist (in the Scholastic/Peircean sense), since structures must be general (see Chapter 1.4). But insofar as its proponents endorse the correspondence view of truth, it is conceiving of structures as actual existents rather than as indeterminate laws—or in other words it is conceiving of structures on the model of individuals—and is therefore nominalist: recall that the issue upon which realism and nominalism dispute is whether there is anything real other than the actual. We can thus see that OSR is straddling two incompatible metaphysics, nominalism and realism. The only way that the OSRist can be logically consistent is to expunge the residue of nominalism from his system and embrace Scholastic realism, along with the idealism that it necessarily en-

tails. This move will at once solve the second of the difficulties faced by OSR, that it cannot give an adequate account of the relation between the world and our representations of the world; since, as we saw in Chapter 1.4, the root of this problem is the nominalistic identification of the *real* with the *actual*.

Against this the OSRist may object that he does not identify the real with the actual, or that which is determinate in all respects, because he recognizes that quantum indeterminacy is real and cannot be ascribed to errors or disturbances in measurement. My reply to this is that quantum indeterminacy is only a rudimentary kind of the indeterminacy that I have in mind. Even if the OSRist recognizes the indeterminacy of certain physical magnitudes of a quantum system, he is identifying the real with the actual insofar as he presupposes that the *laws* of quantum physics are absolutely determinate. A Peircean, on the other hand, would reject the idea that there is any sharp line of demarcation between the state of a physical system and the laws that operate on such states. Both are essentially patterns; the only difference between the two is that a state is a pattern whose rate of change is relatively fast, whereas a law is a pattern whose rate of change is relatively slow.⁵² Thus, if there is such a thing as genuine indeterminacy, then we should expect it to be pervasive rather than restricted to a small part of the universe. For a Peircean realist, the laws of nature are themselves subject to infinitesimal fluctuations; and it is this indeterminacy of laws that allows them to evolve under the governance of the categories, the fundamental elements of thought.

Again, the crucial point that separates the nominalist and the realist is that the realist makes reality continuous with thought, so that the laws of nature differ from representations of those laws only in degree, while the nominalist drives a stake in between reality and thought, so to speak, with the

⁵² This is an idea that has recently been put forth by the theoretical physicist Lee Smolin (see Unger & Smolin 2015: 476–79). It is noteworthy that over the past few years, Smolin has been developing the idea—with explicit reference to Peirce—that the laws of nature evolve.

consequence that their relationship becomes utterly inexplicable. Now I just said that “the laws of nature differ from representations of those laws only in degree,” but we still have not gained a precise understanding of what this “difference in degree” consists in. This brings us to the first difficulty faced by OSR, the issue of the relation between physical and mathematical structure. This issue can be understood as a variant of the issue of the relation between reality and thought: loosely speaking, the mathematical is on the side of thought, while the physical is on the side of reality. Now if reality and thought are to be regarded as continuous, then so ought the physical and mathematical. That is, the difference between physical and mathematical structure ought to be regarded as a difference of degree, since otherwise there would be no way of explaining their relationship (as I remarked in Chapter 1.4). But the question is: what does this “difference in degree” consist in? This question is inseparably bound up with the issue of how we ought to understand the phenomenon of *instantiation*. To this issue we shall now turn.

5. Peirce's Theory of the Continuum

Chaque portion de la matière peut être conçue comme un jardin plein de plantes, et comme un étang plein de poissons. Mais chaque rameau de la plante, chaque membre de l'animal, chaque goutte de ses humeurs est encore un tel jardin ou un tel étang.

G. W. Leibniz, *La Monadologie*

At the end of Chapter 2.2, I remarked that to point at something and call it “lithium” is to treat it as a node within the network of relations of which the concept “lithium” is a symbolic unification. But this still involves the notion of a *something* that can be pointed at and made the object of a judgment. We cannot say anything about *what* it is or *how* it is without reference to general concepts, but there must be a *this*, something that we can point at or turn our attention towards. Is this not what we mean by an *individual*? Here we meet the first of the two problems faced by OSR, that it cannot give an adequate account of the relation between mathematical and physical structure. Recall from Chapter 1.4 that the core of the issue concerns the notion of *instantiation*. Physical structure is structure that we know is *instantiable*, whereas mathematical structure is structure whose instantiability is unknown to us. But what does it mean for a structure to be *instantiated*? It is, apparently, to have some kind of anchor by which the structure, in itself purely general, manifests itself in the actual world. But this anchor cannot itself be of the nature of a structure, since, as we saw in Chapter 1.4, a general can in no way differentiate between the actual and non-actual. How, then, can we make sense of the nature of this anchor? In what follows we shall see how Peirce approaches this problem; and indeed this is where Peirce, with his deep acquaintance with the Scholastic doctors as well as with modern mathematics and logic, is at his best.

5.1 Secondness as the Category of Individuation

Let us begin by considering the difference between the actual and non-actual from the standpoint of Peirce's categories. Suppose that there is a fire burning in front of me. In my imagination I can change the properties of the fire at will; for example I can change its color, its smell, etc. I can also pretend in my imagination to put my hand into the fire, without feeling any pain. Such is the nature of a non-actual fire. The various images of fire that I conjure in my imagination are possible variations of the fire encompassed under the general concept of fire. Now the actual fire burning in front of me cannot be changed in the way that a non-actual fire can. I cannot change its color or its smell by the mere act of thinking; and if I put my hand into it, the consequences are painful. There is in it an *uncontrollable element*, a resistance against the will. This is the way in which the category of Secondness, or Reference to a Correlate, manifests itself in the phenomena.

Here, it should be emphasized that I am not claiming that there is an *absolute* difference between the actual and non-actual. Even in pure mathematics there is a kind of conceptual friction, as it were, that constrains the process of reasoning. Thus, as I remarked above, the difference between physical structure and mathematical structure must be a difference of degree; and Peirce's theory of the categories suggests that this degree is the degree of Secondness relative to something else.

Recall that Secondness is the category of blind relation. It must be *blind* because if there is any intelligibility in it, then there must be a Third that is supplying that intelligibility by serving as its sign. One way in which such a blind relation manifests itself in the phenomena is in brute action and reaction between two agents, of which resistance against my will can be understood as a special case. Against this it may be objected that action and reaction is nothing but a feeling of Quality, and is therefore of the nature of a First. The reply to this is that although it is true that there is a Quality to every instance of action and reaction, yet the action and reaction itself cannot be reduced to that Quality. Consider, for example, the sound of a pin being dropped in a completely silent room. Next,

consider the sound of the same pin being dropped during a party or parade. Let us suppose that the Quality of the sound considered in itself—as a First—is identical in the two cases. We know from experience that there will still be a difference between these two cases, namely in the way that the sound *forces* the attention of the mind towards it. This is a difference in the degree of Secondness relative to the mind. In “The Law of Mind,” Peirce recalls how his memory of the color of a cardinal’s robes, which he saw many years before, has become dimmed, and yet the color itself is not remembered as dim (W8: 149, 1892). This shows that the *vividness* or *insistence* of an idea or sensation is something of an altogether different nature from its Quality. It is, as Peirce puts it, an intrusion into the Ego of a Non-Ego (EP2: 154, 1903), an opposition or clash between two agents.

Secondness is what makes a possibility actual and confers to it its *here-and-now-ness*. Experience shows that the insistency of an idea or sensation diminishes over time, and this is only natural if we regard Secondness as the category of actualization, since *actual* is simply another word for *here and now*. Now even if something is not reacting against my will at this very moment, if it is of such nature that it reacts against other things, I infer that *if* it were made the object of my will, then it *would* react against it. In other words, the actual is that which is at least virtually reactive against my will. Remembering that *actual* is synonymous with *individual* (Chapter 4.1), these considerations afford us with the following categorial definition of *individual*: “an individual is something which reacts. That is to say, it does react against some things, and is of such a nature that it might react, or have reacted, against my will” (CP 3.613, 1901). Secondness can thus be said to be the category of individuation. By an individual we shall mean a *relative individual* (as defined in Chapter 4.1), since, as we have seen, the notion of an absolute individual is a contradictory notion.

Recall that a relative individual is something that may be made more determinate, but is logically indivisible relative to a certain grain of observational or conceptual resolution. Now in order for it to be susceptible of further determination, it must contain an element of generality in it, since it must

be indeterminate in the respect in which further determination is possible. Then the question arises: how can something be individual, and yet contain in it an element of generality? What does it mean for something to “contain” an element of generality in the first place? Peirce’s theory of *continuity* will help us in giving a precise answer to these questions, by providing an abstract model of generals, individuals, and the instantiation relation between them. Furthermore, it will allow us to see in a vivid way why exhibiting patternhood is a necessary condition for the very possibility of cognition, as noted in the Introduction in connection with the example of the “snow” noise that appears on analog TV screens receiving no transmission signal.

5.2 The Mathematical Theory of the Continuum

My approach to Peirce’s concept of continuity will be chronological, focusing on how his conception of the continuum developed over his lifetime. This approach, I believe, will put into relief the issues that motivated Peirce’s mature conception of the continuum as a “supermultitudinous” collection, a collection whose multitude is greater than that of any discrete multitude, and whose members are no longer distinct individuals but are “fused together.”

Potter & Shields (1977), Havenel (2008), and Maddalena (2009) each attempt to divide the development of Peirce’s conception of continuity into distinct periods. Potter & Shields distinguishes the following four periods:

- (1) Pre-Cantorian Period: until 1884
- (2) Cantorian Period: 1884–1894
- (3) Kantistic Period: 1895–1908
- (4) Post-Cantorian Period: 1908–1911.

Havenel (2008) distinguishes the following five periods:

- (1) Anti-nominalistic Period: 1868–1884
- (2) Cantorian Period: 1884–1892
- (3) Infinitesimal Period: 1892–1897
- (4) Supermultitudinous Period: 1897–1907
- (5) Topological Period: 1908–1913

Furthermore, Havenel criticizes Potter & Shields’s identification of a “Kantistic” period, arguing that is based on an editorial blunder in the *Collected Papers* (Havenel 2008: 103). Namely, Peirce asserts in CP 6.166 that “continuity consists in Kanticity and Aristotelicity.” A close examination of the manuscripts shows that this was written in 1892–1893, but according to Havenel, Potter & Shields follow the editorial affirmation in the *Collected Papers* that this section was written in 1903, and therefore mistakenly attribute the “Kantistic” conception of continuity to a period in which Peirce had already abandoned it (Havenel 2008: 104). This criticism, however, seems to be based on a confusion on Havenel’s part, namely, that of linking Potter & Shield’s “Kantistic” period with his “infinitesimal” period, where in fact it should correspond to Havenel’s “supermultitudinous” period. Potter & Shields make it clear that they are not using “Kanticity” in the sense of infinite divisibility, which was the meaning that Peirce attributed to the term before 1899.⁵³ In a 16 March 1900 letter to the editor of *Science*, Peirce writes:

Although Kant confuses continuity with infinite divisibility, yet it is noticeable that he always defines a continuum as that of which every part ... has itself parts. This is a very different thing from infinite divisibility, since it implies that the continuum is not composed of points ... (CP 3.569, 1900)

⁵³ This date is based on a letter that Peirce sent to Paul Carus on August 17, 1899. See W8: 394, ann. 143.16–19.

Peirce is here clearly using Kant's definition of continuity to describe his supermultitudinous conception of continuity, as an entity not composed of distinct points. It is thus puzzling why Havenel has to criticize Potter & Shields's labeling Peirce's supermultitudinous period "Kantistic," apart from the fact that they place its beginning perhaps a bit too early, in 1895. Maddalena's (2009) division is similar to Havenel's, the differences being that he calls the first period "Pre-Cantorian" instead of "anti-nominalistic," the third period "Aristotelico-Kantian" instead of "infinitesimal," and identifies a sixth "crisis" period between the supermultitudinous and topological periods, from 1905–1907. I think the term "Aristotelico-Kantian" is better than "infinitesimal," since Peirce's endorsement of infinitesimals is by no means restricted to 1892–1897. The issue of whether we can discern a period of crisis between 1905 and 1907 will have no direct bearing on my discussions in this thesis. I will follow Havenel and Maddalena's division; but one point that deserves emphasis is that Peirce's topological approach to continuity is in no way confined to the period after 1908: already in the Cambridge Conferences Lectures of 1898, we can see Peirce applying his ideas on topology to his theory of the continuum and his cosmology.

With these clarifications in place, let us trace the development of Peirce's conception of continuity. My exposition will not be comprehensive, but will merely outline the major steps that led to his supermultitudinous conception in 1897.

While we can find germs of Peirce's synechism in early works such as the last section of "Questions Concerning Faculties Claimed for Man" (W2, Sel. 21, 1868) and the opening section of "The Doctrine of Chances" (W3, Sel. 62, 1878), it was not until Peirce had read Georg Cantor's *Grundlagen einer allgemeinen Mannichfaltigkeitslehre* (Cantor 1883; hereinafter *Grundlagen*) in late 1883 or early 1884, most likely in the French translation published in *Acta Mathematica* (see Moore 2011: 324), that his study of continuity became a rigorous enterprise. This is not to say that

Peirce had no interesting ideas concerning continuity prior to 1884; it is only that those ideas were in a germinal form, awaiting fruition in the fertile soil of mathematics.

During the period spanning from 1884 to 1892, Peirce more or less accepts Cantor's definition of the continuum, which he gives in §10 of the *Grundlagen*, as a series of points that is *concatenated* (*zusammenhängenden*) and *perfect* (*perfecte*). Peirce defines these terms in his contribution to the *Century Dictionary* as follows:

Cantor calls a system of points *concatenated* when any two of them being given, and also any finite distance, however small, it is always possible to find a finite number of other points of the system through which by successive steps, each less than the given distance, it would be possible to proceed from one of the given points to the other. He terms a system of points *perfect* when, whatever point not belonging to the system be given, it is possible to find a finite distance so small that there are not an infinite number of points of the system within that distance of the given point. (CP 6.164, c.1884)

Thus a series S is said to be *concatenated* if for every $t \in S$, every $t' \in S$, and every $\varepsilon > 0$, there exists a finite number of t 's belonging to S , t_1, t_2, \dots, t_n , such that $|t_1 - t| < \varepsilon, |t_2 - t_1| < \varepsilon, \dots, |t' - t_n| < \varepsilon$. A series is concatenated only if there exists a term between every two (for if there were two points between which there is no third point, then we can let ε be a distance smaller than the distance between these two points, violating the condition of concatenated-ness), although the converse does not necessarily hold. A series S is said to *perfect* if it contains "every" element t such that for every $\varepsilon > 0$, there exists an infinite sub-series $S' \subset S$ such that for every $t_i \in S'$, $|t - t_i| < \varepsilon$. This is equivalent to saying that S contains every point that is a limit-point of an infinite sub-series; or in other words, any point *not* contained in S is an "isolated" point.

In 1892, however, Peirce begins to criticize Cantor's definition of continuity. One problem with this definition, according to Peirce, is that it "turns upon metrical considerations; while the distinc-

tion between a continuous and discontinuous series is manifestly non-metrical” (W8: 144). That is, it assumes that a distance metric is defined on the series, whereas it is possible for a series to be continuous without having such a metric. Continuity is a topological property, not a metrical one. Another problem is that Cantor’s definition of a “perfect” series involves reference to “every point” of a certain description. But “no positive idea is conveyed of what all the points are: that is definition by negation, and cannot be admitted” (W8: 144). By “definition by negation,” Peirce probably means that Cantor defines a “perfect” series by giving a characterization of the points that should be excluded from the series, without giving a positive idea of what the points that are not excluded are.⁵⁴

Peirce’s alternative is to define continuity in terms of what he calls the properties of *Kanticity* and *Aristotelicity*. A series satisfies Kanticity if there exists a term between every two—a more general version of concatenated-ness. But this condition is not enough to define a continuum, since it is satisfied by e.g. the series of rational numbers, which is manifestly not continuous. Thus in order to give an adequate definition of continuity we must mend the definition in terms of Kanticity:

Kant’s definition expresses one simple property of a continuum; but it allows of gaps in the series. To mend the definition, it is only necessary to notice how these gaps can occur. Let us suppose, then, a linear series of points extending from a point, A, to a point, B, having a gap from B to a third point, C, and thence extending to a final limit, D; and let us suppose this series conforms to Kant’s definition. Then, of the two points, B and C, one or both must be excluded from the series; for

⁵⁴ As Myrvold (1995: 521) points out, Peirce’s second criticism seems a bit off the mark. In §10 of the *Grundlagen*, Cantor is concerned with identifying the conditions for subsets of real numbers and n -dimensional spaces \mathbb{R}^n to be continuous, where he has already defined real numbers in terms of Cauchy sequences of rationals in the previous section. That is, Cantor has already specified what “every point” not excluded from the continuous series is. Yet, it could be argued that Peirce’s criticism is justified, insofar as Cantor’s definition takes for granted a background topology, and therefore does not give a definition of continuity as an intrinsic property of a series.

otherwise, by the definition, there would be points between them. That is, if the series contains C, though it contains all the points up to B, it cannot contain B. What is required, therefore, is to state in non-metrical terms that if a series of points up to a limit is included in a continuum the limit is included. (W8: 144, 1892)

The structure of this argument can be rendered thus: if there is a gap in a series S, then there is at least one sub-series of S which does not contain its limit (least upper bound or greatest lower bound). The problem with Kant's definition of continuity is that it is consistent with the existence of such gaps. Therefore, in order to mend this definition, we take the contrapositive of the aforementioned conditional: "if every sub-series of S contains its limit (least upper bound or greatest lower bound), then series S does not have any gaps." Peirce calls the property stated in the antecedent of this conditional *Aristotelicity*. By combining Kant's definition with Aristotelicity, we get an adequate definition of continuity. Note that Aristotelicity alone is not sufficient to define a continuum, since e.g. the series of integral numbers satisfies the condition although it is not continuous.

Peirce's definition of continuity is a generalized version of Richard Dedekind's construction of the real numbers by Dedekind cuts on the series of rational numbers. By "generalized" I mean that it does not make reference to numbers as does that of Dedekind, although it certainly defines a structure isomorphic to the real number series. Peirce then goes on to argue that according to his definition, continuity presupposes infinitesimals—*infinitesimal* being understood as the "infinitieth place of a decimal"—for the reason that it contains the incommensurable as well as commensurable numbers (W8: 145). But this must be the result of a confusion. For as Matthew Moore points out in his headnotes for the "Law of Mind" in *Philosophy of Mathematics*, Aristotelicity rules out infinitesimals:

A monotone infinite sequence of infinitesimal steps, beginning at 0, would be bounded above by any finite number; but it would have no least upper bound, since

the sum of two infinitesimals is itself infinitesimal, and there is no smallest finite positive number. (PM: 143)

That is, since a series of infinitesimals does not contain its limit, it is ruled out by Aristotelicity.

Another tension in Peirce's thought during this period becomes evident in his application of the concept of continuity to the problem of boundary elements:

Suppose a surface to be part red and part blue; so that every point on it is either red or blue, and, of course, no part can be both red and blue. What, then, is the color of the boundary line between the red and the blue? The answer is that red or blue, to exist at all, must be spread over a surface; and the color of the surface is the color of the surface in the immediate neighborhood of the point. I purposely use a vague form of expression. Now, as the parts of the surface in the immediate neighborhood of any ordinary point upon a curved boundary are half of them red and half blue, it follows that the boundary is half red and half blue. (W8: 145–46)

There is an air of absurdity in the statement that “every point is either red or blue” yet “the boundary is half red and half blue.” I think the difficulty is this: to say that the boundary is half red and half blue implies a violation of the Law of Excluded Middle, the principle that for any proposition P, either P or not-P must be true, for here Peirce is saying that the boundary is neither red nor not-red (and neither blue nor not-blue), but a third middle state. Now as Peirce will make clear in his later writings, the Law of Excluded Middle applies only to distinct individuals—it does not hold on a continuum, which is, from the standpoint of the supermultitudinous conception, no longer a collection of distinct individuals at all but a system of *potential* points. Indeed, an individual can be characterized as that for which the Law of Excluded Middle (and the Law of Non-Contradiction) holds, since it is anything that is determinate in all respects. The problem here is that Peirce is speaking as though the boundary line were a distinct individual; and here we can see that he is still unable to

escape the influence of the Cantorian conception of the continuum as a collection of points. This is also probably the reason why he is unable to properly harness the infinitesimal concept at this stage.

The breakthrough comes with Peirce's discovery in 1896 of what is today known as Cantor's theorem. Independently but under the influence of Cantor, Peirce discovers the diagonal argument, and uses it to prove that for every collection of multitude N , finite or infinite, there exists a collection of multitude $2^N > N$. Here it is unnecessary to go into the details of Peirce's proof.⁵⁵ Significant for our purposes are two facts. The first is that Peirce uses Cantor's theorem to obtain the result that the infinite multitudes can be arranged in a denumerable (countably infinite) series. That is, if we denote the denumerable multitude (the multitude of natural numbers) as \aleph_0 and 2^x as $\exp(x)$, then we obtain the denumerable series:

$$\aleph_0, \exp(\aleph_0), \exp(\exp(\aleph_0)), \exp(\exp(\exp(\aleph_0))), \dots$$

Let us follow Moore (2007) in calling this result—that there is a denumerable series of infinite multitudes, and that this series contains *all* of the infinite multitudes—Peirce's *Step Lemma*. The Step Lemma assumes the Generalized Continuum Hypothesis, that for any infinite set S , there is no cardinal lying between the cardinality of S and the cardinality of the power set of S . Peirce tried on

⁵⁵ As early as 1892, Peirce gives a proof of the existence of two distinct grades of infinity—the countable and uncountable—using a kind of diagonal argument (MS 1573: 82, 590: 16–18; forthcoming in W9). However, this diagonal argument relies on the notion of permutations of elements rather than on power set constructions as in his later diagonal proofs; and therefore it is unable to establish the general theorem, that for every collection of multitude N , there exists a collection of multitude $2^N > N$. Peirce's first proof of Cantor's theorem is in Art. 17 of "On Quantity, with special reference to Collectional and Mathematical Infinity" (NEM 3: 51–52, 1896). See also the third of the 1898 Cambridge Conferences Lectures (RLT: 158) and "Prolegomena to an Apology for Pragmatism" (CP 4.532, 1906) for examples of Peirce's later diagonal proofs. I wish to express my gratitude to Dr. Matthew Moore, who offered valuable comments regarding the 1892 proof in personal correspondence.

several occasions to prove the continuum hypothesis, both in its general and special form, but was never satisfied with his argument. For the most part he seems to have assumed it to be true (Myrvold 1995: 514–15). Today we know that the continuum hypothesis is independent of (cannot be proved or disproved within) the standard set theory; and the bearings of this on Peirce’s conception of the continuum as a supermultitudinous collection is an open question that must be reserved for future research. Here I will simply point out that Peirce himself seems to have thought that his identification of the supermultitudinous collection with the continuum does not turn upon the truth of the continuum hypothesis, for he remarks at one point that the continuum hypothesis is not as important as the question of whether there is a multitude greater than all abnumerable (uncountable) multitudes: “Yet so far as I know (I am not acquainted with the work of Borel, of which I have only quite vaguely heard), it has never been exactly proved that there are no multitudes between two successive abnumerable multitudes, nor, which is more important, that there is no multitude greater than all the abnumerable multitudes” (CP 4.656, 1908). In any case, I will set aside the continuum hypothesis for now and proceed upon the assumption that Peirce’s argument is unaffected by it.

The Step Lemma plays an important role in Peirce’s conception of continuity as a *supermultitudinous* collection, because he defines the supermultitudinous collection as the “limit” of the series $\aleph_0, \exp(\aleph_0), \exp(\exp(\aleph_0)), \dots$ (NEM 3.86, c.1897). Specifically, he asks us to consider the union of the collections of every assignable multitude (NEM 3.86, c.1897; see also RLT: 158–59, 1898). That is, this collection consists of the members of all the finite multitudes, together with the members of all the possible collections of those multitudes, together with the members of all the possible collections of collections of those multitudes, and so on *ad infinitum*. This collection, the supermultitudinous collection, is a collection whose multitude is greater than all \aleph_n for finite n . The very conceivability of such a collection gives rise to a version of Cantor’s Paradox. Namely, if we denote the multitude of the supermultitudinous collection as Ω , then it follows that $2^\Omega = \Omega$, since taking the

power set of the supermultitudinous collection does not increase its multitude. Peirce's reasoning is as follows:

[The supermultitudinous collection is] the result of a denumerable succession of exponential operations upon the denumerable multitude. But the magnitude of the collection of possible ways of distributing the individuals of a collection into two abodes is simply the result of an exponential operation upon the magnitude of the collection itself. Hence the magnitude of the ways of distributing the individuals of a supermultitudinous collection into two abodes is obtained by adding one more to the collection of collection of exponential operations successively performed upon the denumerable multitude. But this collection of operations being denumerable, the addition of one operation to it does not increase its multitude. Hence, the collection of possible ways of distributing the individuals of a supermultitudinous collection into two abodes equals that collection itself. (NEM 3.86, c.1897)

Thus $2^\omega = \Omega$, in violation of Cantor's theorem. The fallacy in this argument has been explained by Myrvold (1995: 515–17). Namely, Peirce is confusing $\omega + 1$, the order type of a sequence of \aleph_0 elements with one more added to the *end*, with $1 + \omega$, the order type of a sequence of \aleph_0 elements with one more added at the *beginning*. It would be correct to say that $1 + \omega$ is the same as ω , but the order type of the infinite sequence of exponentiations that defines the power set of the supermultitudinous collection is $\omega + 1$, not $1 + \omega$; and $\omega + 1$ is not the same as ω . Nonetheless, Peirce's basic point holds if we consider a collection that contains, for every collection of multitude \aleph_n , a collection of multitude \aleph_{n+1} or $\exp(\aleph_n)$, since such a collection would have a multitude greater than every possible multitude, in violation of a direct corollary of Cantor's theorem, that there is no greatest multitude.

Interestingly, Peirce does not conceive of this result as a “paradox” at all. This brings us to the second significant fact: Peirce qualifies the applicability of Cantor's theorem so that it only holds for collections composed of *distinct individuals*. This qualification is justified by the fact that the

proof of Cantor's theorem requires us to assign to each member of a collection a collection of elements of that collection and judge whether or not each of those members falls under the collection to which it is assigned, which would be impossible if those members were not determinate in regard to every possible collection, either as falling under it or not falling under it (this is easier to see if, instead of considering collections under which elements either fall under or do not fall under, we consider predicates which are either affirmed or denied of objects. Indeed, Peirce's first proof of Cantor's theorem in "On Quantity" is couched in terms of predicates rather than collections). Therefore, the fact that the supermultitudinous collection violates Cantor's theorem is taken as proof that the supermultitudinous collection does not consist of distinct individuals at all—it is so vast a multitude that the members lose their distinct identities and are welded together in *continuity* (RLT: 159, 1898).

Later, Peirce will explicitly reject the Cantorian continuum (the set of real numbers) as a *pseudo-continuum*, and argue that a true continuum cannot be reduced to a collection of points, however infinitely large (CP 6.176, 1908). Rather, the true continuum derives its essence from the *mode of connection* between its elements. The mode of connection that defines a true continuum is that of "immediate connection" (CP 4.642, 1908). Two elements, A and B, are said to be immediately connected if they are in some sense identical. But what does this mean? If they are identical, then how can we say that they are two elements, A and B?

An example that Peirce gives in the third of his 1898 Cambridge Conferences Lectures to illustrate his supermultitudinous conception of continuity will serve to clarify this point (RLT 159–60, 1898). Suppose we draw a point on a continuous line. We then cut the line at the point, so as to produce a left-hand region (L) and right-hand region (R). The original point then becomes two points, one at the right end of L and one at the left end of R. If we rejoin the two ends, the points

again become a single point.⁵⁶ And we have no reason for restricting this to two points: “The end of a line might burst into any discrete multitude of points whatever, and they would all have been one point before the explosion. Points might fly off, in multitude and order like all the real irrational quantities from 0 to 1; and they might all have had that order of succession in the line and yet all have been at one point” (RLT: 160).

Any multitude of immediately connected elements can thus be identical but *potentially distinct*, that is, they may possess an order such that if a discontinuity is imposed on the line, their difference becomes apparent. But before the imposition of discontinuity, the elements cannot be said to be distinct at all. They are only *potential* points, and the notions of identity and distinctness do not, properly speaking, apply to potentials; they only apply to individuals. Thus the continuum, “being a potential aggregate only, ... does not contain any individuals at all. It only contains general conditions which *permit* the determination of individuals” (RLT: 247, 1898). Relations do not hold between individual elements of the continuum; rather, the continuum *is* the relational (in this case, topological) structure itself, and individuality is brought about only as the result of extrinsic determination.⁵⁷

So far we have discussed three defining characteristics of the Peircean continuum: its supermultitudinousness, its inextensibility (the property of not being composed of distinct individuals), and the potentiality of its elements. One more important characteristic is what Zalamea (2012: 16–18)

⁵⁶ This, of course, is clearly different from the situation in a Dedekind cut, where the two regions produced by the cut are not always mirror images of each other: namely, in the case of a Dedekind cut corresponding to a rational number, one of the regions has a greatest (or least) member while the other does not. In the Peircean cut, however, the two regions produced are always mirror images of each other.

⁵⁷ As Johanson (2001) points out, although Peirce’s ideas on the continuum are in conflict with modern point-set topology, they are in agreement with the concepts of pointless topology. Connections have also been drawn with Smooth Infinitesimal Analysis, an approach to analysis based on the category-theoretic ideas of F. William Lawvere; see Herron (1997: 621–23) and Havenel (2008).

has called its *reflexivity*, namely, the property of every part having a structure identical or similar to the whole. In other words, in the Peircean continuum every part *reflects* or *mirrors* the whole. Reflexivity immediately implies that the continuum cannot be composed of points, since a point is precisely that which does not have any parts, and as such it cannot mirror the structure of the whole, which is composed of parts. This is the reason why Peirce calls continuous predicates “continuous.” Recall from Chapter 3.2 that a continuous predicate is a predicate that can be “analyzed into parts all homogeneous with the whole” (SS: 72). This is precisely the property of reflexivity, one of the defining characteristics of the Peircean continuum.

5.3. Continuity, Generality, and the Inexhaustibility of Nature

Thus in outline is Peirce’s mathematical conception of continuity. It may be asked how this conception has bearings on the world outside of mathematics. Here it must be observed that for Peirce, *generality is nothing but a rudimentary form of continuity*: “corresponding to generality in nonrelative logic is continuity in relative logic” (L 390: 5, Letter to F. C. S. Schiller, 12 May 1905); “continuity is shown by the logic of relations to be nothing but a higher type of that which we know as generality. It is relational generality” (RLT: 258); “the doctrine of the reality of continuity is simply that doctrine the scholastics called realism” (MS 398: 12, 1893). Despite the crucial importance that the “continuity = relational generality” equation plays in Peirce’s philosophy, it must be admitted that he is never sufficiently clear about the exact nature of this equation. My view is that the mathematical continuum is a model of the logical structure shared by all generals, in much the same way that a quadratic equation is a model of the time-displacement relation of a falling body.

Let us first see how the supermultitudinousness, inextensibility, and potentiality of the Peircean continuum capture the structure of generals. Just as a continuum is a space of possible elements, so a general concept delimits a space of possible instantiations, instances in which it is applicable as a

predicate. Since for any two instantiations with similar characteristics, it is possible to conceive of a continuously infinite multitude of possibilities with characteristics that fall between the two, the multitude of possible variations can never exhaust the general concept:

Take any two possible objects that might be called *suns* and however much alike they may be, any multitude whatsoever of intermediate suns are alternatively possible and therefore ... these intermediate possible suns transcend all multitude. In short, the idea of a general involves the idea of possible variations which no multitude of existent things could exhaust but would leave between any two not merely *many* possibilities, but possibilities absolutely beyond all multitude. (EP2: 183, 1903)

In Chapter 3 we saw that a general cannot be reduced to (that is, explained in terms of) its individual instantiations, because it has reference to every *possible* instance of a general type, including future instances that may never be actualized. Peirce's reformulation of this irreducibility in terms of supermultitudinousness allows us to see a neat correspondence between continuity and generality: just as a continuum is something more than a mere collection of points, so a general is something more than a mere collection of its individual instantiations. Furthermore, just as in the case of the continuum, it makes no sense to speak of the identity or distinctness of a general's instantiations prior to their instantiation. They are "fused" together in the overall structure, so to speak, and it is only in actualization that they can be discerned as individuals: "continuity and generality are two names for the same absence of distinction of individuals" (CP 4.172, 1897).

There is, however, a deeper correspondence between continuity and generality. The pragmatic maxim tells us that all generals can be explicated into correlations that dictate what *would* occur under conceivable circumstances. As we saw in Chapter 3.3, these correlations are Thirds, because their being consists in a power of establishing relations between two objects. Now reference to a Third cannot be prescinded from reference to a First and Second, and therefore a Third can only be

understood as a term of a triadic relation. And a triadic relation can always be analyzed, via hypostatic abstraction, into a relation containing the teridentity term, 1^3 . The teridentity term is a continuous predicate—or rather it is the continuous predicate *par excellence*, since it is what makes all other continuous predicates continuous—because it is analyzable into parts absolutely homogeneous with the whole. Therefore generals can be explicated into correlations, which, so far as their pure form is concerned, are themselves continua. Furthermore, the general is a welding together of these correlations (again, by Thirdness) into the unity of an idea, making it a continuum of continua. The precise relation of these properties of the general with the property discussed above, namely its irreducibility to actual existents, is a topic requiring further investigation.

Now since a pattern is either a general Form or manifestation of a general Form (Chapter 3.3), it follows from the identity of generality and continuity that a pattern must be a continuum or a manifestation of a continuum. This is only natural, considering that a continuum is a *regularity* among its parts (as implied by the property of reflexivity), and that “regularity” is simply another word for “pattern”:

A perfect continuum belongs to the genus, of a whole all whose parts without any exception whatsoever conform to one general law to which same law conform likewise all the parts of each single part. *Continuity* is thus a special kind of *generality*, or conformity to one Idea. More specifically, it is a *homogeneity*, or generality among all of a certain kind of parts of one whole. Still more specifically, the characters which are the same in all the parts are a certain kind of relationship of each part to all the coordinate parts; that is, it is a *regularity*. (CP 7.535n6, 1908)⁵⁸

⁵⁸ Peirce’s claim that continuity is a special kind of generality may seem to suggest that there are generals that are not continua. However, we should pay attention to the adjective “perfect” in Peirce’s definition. I think that Peirce’s definition should be understood in this way: a *perfect* continuum is a special kind of generality, while there are generals that correspond to *imperfect* continua, that is, continua with topological singularities (CP 4.642, 1908). This would in turn im-

Thus, we can say that *patternhood*, *generality*, and *continuity* are three ways of describing the same state of affairs, namely a conformity to a law.

With these results in place, let us return to our question of *instantiation*. In light of our identification of generality and continuity, we can say that instantiation is the imposition of a discontinuity on a continuum. The fire here and now, for example, is a discontinuity marked upon the continuum of possible fires—it is at once a reaction against the will, and a “crowding out,” as Peirce puts it (NEM 4.135, 1897), of other possibilities from so reacting: “individual existence depends upon the circumstance that not all that is possible is possible in conjunction” (NEM 4.135, 1897), “a *this* is something positive and insistent, but it only is so by pushing other things aside and so making a place for itself in the universe” (NEM 4.136, 1897).

Recall that to explain a *this* is to subsume it under a general concept, and thereby treat it as a node within a network of relations. But in order for us to be able to turn our attention towards the *this* and make it an object of inquiry, it must be *intelligible*, something open to cognizance. And in order for the *this* to be intelligible, there must already be in it an element of generality or continuity, some kind of regularity which the mind can seize upon, whether it be a regularity in space, time, or some other dimension: “Generality is, indeed, an indispensable ingredient of reality; for mere individual existence or actuality without any regularity whatever is a nullity. Chaos is pure nothing” (EP2: 343, 1905). This brings us back to the example of the “snow” noise mentioned in the Introduction. There, I noted that in order for the noise to be perceptible, it must display some kind of regularity; although the noise itself is not a regularity, it can only be discerned upon the backdrop of

ply that generals have a topological structure, which is indeed what Peirce seems to have had in mind since as early as 1898: “If metaphysics is really to be made a definite science, and not child’s play, the first inquiry concerning any general must be, first, what its dimensionality is, and second, what those intermediate Listing numbers are ...” (RLT: 264, 1898).

a regularity or series of regularities. In other words, exhibiting patternhood is a necessary condition for the very possibility of cognition. The reason for this becomes clear when we look at patternhood from the standpoint of continuity.

As I have been emphasizing, an individual must contain in it an element of generality in order for it to be cognizable. Now an individual can have an “element of generality” in it only if it is a determination of a higher dimensional continuity. A continuum is an embodiment of a law that governs the manner of its determinations, and as such it is the background upon which alone individuals can come into being. Peirce’s analogy of the blackboard in the last of his 1898 Cambridge Conferences Lectures illustrates this point vividly:

Let the clean blackboard be a sort of diagram of the original vague potentiality ... I draw a chalk line on the board. This discontinuity is one of those brute acts by which alone the original vagueness could have made a step towards definiteness. There is a certain element of continuity in this line. Where did this continuity come from? It is nothing but the original continuity of the blackboard which makes everything upon it continuous. (RLT: 261–62)

In much the same way, the individuals that we experience in this world can themselves be understood as continua marked upon continua of a higher dimensionality—they are *topological singularities* within the higher dimensional continua. Note also that Peirce says that this discontinuity is a *brute act* that determines the original potentiality. It is “brute” because it has no *reason*—there is no way of explaining why it is *this* thing in front of me that was actualized rather than some other possibility. It is through such brute action and reaction with the environment—of which resistance against my will can be understood as a special case—that generals become instantiated here and now.

We can thus see how Peirce's theory of the continuum, along with the theory of the categories, affords us with a way of understanding the distinction between physical and mathematical structure in a non-question-begging way, by explaining the phenomenon of *instantiation* as the result of the operation of universal principles. Furthermore, Peirce's theory of the continuum allows us to see a deep connection between patternhood and generality that I have been gesturing towards throughout this thesis, namely, that the impossibility of the absolute individual is equivalent to the central thesis of OSR, that there is no bit map representation of the world. For if there were a bit map representation, then the world would consist of discrete ultimate units, to each of which is assignable a "bit" (or any other unit) of information. These ultimate units must be absolute individuals, for if they were indeterminate in some respect, then there would be no way of assigning a unit of information in regard to that respect. Against this it may be objected that the unit of information used in the bit map need not be discrete but instead could be continuous, and that a continuously varying sign can be used to completely capture an indeterminate dimension. The reply is that whatever is indeterminate in some dimension must be supermultitudinous in its possible variations along that dimension, and such a multitude of possible variations cannot be captured by a string of signs, however infinitely long. Thus, if there were a bit map representation of the world, then the world must be composed of discrete units. Conversely, if the world consisted of discrete units, then there would (in principle) be a bit map representation of it. Thus, to say that the world is continuous and to say that it is "real patterns all the way down" are two ways of expressing the same fact, that Nature is inexhaustible.

Concluding Remarks

We have seen how Peirce's philosophy—his pragmatism, theory of categories, Scholastic realism, and theory of the continuum—not only diagnoses the root of the problems faced by OSR, but also provides us with a remedy. Furthermore, we have seen how Peirce's philosophy leads us to a worldview very similar to that of OSR, via a line of reasoning that is completely different from those standardly used to argue for OSR, condensable into a simple syllogism: exhibiting patternhood is a necessary condition for the possibility of cognition; cognizability is a necessary condition for something to be real; therefore, anything that is real must exhibit some kind of patternhood or, which amounts to the same thing, anything that is real must be a pattern. The line of reasoning is different in part because, as we saw in Chapter 4, the metaphysics of OSR is based on physics, whereas the metaphysics of Peirce is based on mathematics and logic. To recapitulate: in Peirce's late classification of the sciences, metaphysics is based only upon mathematics, phenomenology, and the normative sciences (which includes logic). The special sciences, including physics, only come after metaphysics. For the proponents of OSR on the other hand, metaphysics comes after the special sciences.

The question I want to pose is this: is Peirce's classification of the sciences still valid today, in light of the revolutions we have seen in physics since his time? The subject matter, and to some extent even the methods of research have changed so drastically that it is hardly the same discipline. Peirce viewed physics as the study of matter, and (being an idealist) held that matter is "mind hide-bound with habits" (W8: 155, 1892). Recall that for Peirce, there is a universal tendency for thought to drift towards a state of fixity—he called this the *principle of habit-taking* (e.g. W6: 208, 1887–1888; W8: 179, 1892). My view is that physics is no longer the study of effete mind, but rather the study of a realm in which the spontaneity of mind has not yet been subdued by the principle

of habit-taking. May it not be that we have probed so deep into reality that we are beginning to see thought at work in its utmost purity? And by “thought” I do not mean thought in the head of this or that human—that would be nominalistic—but the thought of Nature itself. If this is so, and if logic is understood as the study of the formal laws of thought, then what becomes of the distinction between logic and physics? Is it not this distinction that is blurred rather than the distinction between mathematics and physics? What implications does this have for the proper methodology of metaphysics? My hope is that an inquiry into such questions will bring about a mutual fecundation between the different stripes of OSRists on the one hand and the Peirceans on the other.

References

- Aames, Jimmy J. 2015 (online text). "Peirce's 'Extreme' Realism and Supermultitudinous Conception of Continuity." Available at: http://www.academia.edu/12635422/Peirces_Extreme_Realism_and_Supermultitudinous_Conception_of_Continuity
- Alston, William P. 1955. "Pragmatism and the Verifiability Theory of Meaning." *Philosophical Studies* 6 (5): 65–71.
- Bennett, Charles H. 1988. "Logical Depth and Physical Complexity." in *The Universal Turing Machine: A Half-Century Survey*, ed. Rolf Herken. Oxford: Oxford University Press.
- Bellucci, Francesco. 2013. "Peirce's Continuous Predicates." *Transactions of the Charles S. Peirce Society* 49 (2): 178–202.
- Boler, John F. 1963. *Charles Peirce and Scholastic Realism: A Study of Peirce's Relation to John Duns Scotus*. Seattle: University of Washington Press.
- Burch, Robert W. 1991. *A Peircean Reduction Thesis: The Foundations of Topological Logic*. Lubbock: Texas Tech University Press.
- . 1997a. "Peirce on the Application of Relations to Relations." in *Studies in the Logic of Charles Sanders Peirce*, eds. Nathan Houser, Don D. Roberts, and James Van Evra. Bloomington, IN: Indiana University Press.
- . 1997b. "Peirce's Reduction Thesis." in *Studies in the Logic of Charles Sanders Peirce*, eds. Nathan Houser, Don D. Roberts, and James Van Evra. Bloomington, IN: Indiana University Press.
- Cantor, Georg. 1883. *Grundlagen einer allgemeinen Mannigfaltigkeitslehre, ein mathematisch-philosophischer Versuch in der Lehre des Unendlichen*. Leipzig: Teubner.
- Chaitin, Gregory J. 1975. "Randomness and Mathematical Proof." *Scientific American* 232 (5): 47–52.
- Cao, Tian Yu. 2003. "Can We Dissolve Physical Entities into Mathematical Structures?" *Synthese* 136 (1): 57–71.
- Cover, Thomas M. & Joy A. Thomas. 2006. *Elements of Information Theory*, 2nd Edition. Hoboken, NJ: Wiley-Interscience.
- De Morgan, Augustus. 1864. "On the syllogism, No. IV, and on the logic of relations." *Transactions of the Cambridge Philosophical Society* 10: 331–58 (Read 23 April 1860).
- Dennett, Daniel C. 1971. "Intentional Systems." *The Journal of Philosophy* 68 (4): 87–106.
- . 1989. *The Intentional Stance*, Revised ed. Cambridge, MA: MIT Press.
- . 1991. "Real Patterns." *The Journal of Philosophy* 88 (1): 27–51.
- De Tienne, André. 1996. *L'analytique de la représentation chez Peirce: La genèse de la théorie des catégories*. Bruxelles: Facultés universitaires Saint-Louis.

- Esfeld, Michael & Vincent Lam. 2008. "Moderate Structural Realism About Space-time." *Synthese* 160 (1): 27–46.
- French, Steven. 2014. *The Structure of the World: Metaphysics and Representation*. Oxford: Oxford University Press.
- French, Steven & James Ladyman. 2003. "Remodelling Structural Realism: Quantum Physics and the Metaphysics of Structure." *Synthese* 136 (1): 31–56.
- Hacking, Ian. 1990. *The Taming of Chance*. Cambridge: Cambridge University Press.
- Harman, Graham. 2010. "I Am Also of the Opinion that Materialism Must be Destroyed." *Environment and Planning D: Society and Space* 28: 772–90.
- Havenel, Jérôme. 2008. "Peirce's Clarifications of Continuity." *Transactions of the Charles S. Peirce Society* 44 (1): 86–133.
- Hayek, Friedrich A. 1952. *The Sensory Order: An Inquiry Into the Foundations of Theoretical Psychology*. Chicago: University of Chicago Press.
- Herron, Timothy. 1997. "C. S. Peirce's Theory of Infinitesimals." *Transactions of the Charles S. Peirce Society* 33 (3): 590–645.
- Hookway, Christopher. 2012. "The Principle of Pragmatism: Peirce's Formulations and Illustrations." in *The Pragmatic Maxim: Essays on Peirce and Pragmatism*. Oxford: Oxford University Press.
- Ishida, Masato. 2009. *A Philosophical Commentary on C. S. Peirce's "A New List of Categories": Exhibiting Logical Structure and Abiding Relevance*. Doctoral Dissertation. Accessed 16 June 2015. <http://etda.libraries.psu.edu/paper/9857/4344>
- . 2014. Contribution to *Peirce: 5 Questions*, eds. Francesco Bellucci, Ahti-Veikko Pietarinen, & Frederik Stjernfelt. New York: Automatic Press.
- James, William. 1890. *The Principles of Psychology*, 2 vols. New York: Henry Holt & Co.
- . 1999. *The Correspondence of William James, Vol. 7: 1890–1894*. Charlottesville, VA & London: University Press of Virginia.
- Johanson, Arnold. 2001. "Modern Topology and Peirce's Theory of the Continuum." *Transactions of the Charles S. Peirce Society* 37 (1): 1–12.
- Kantorovich, Aharon. 2003. "The Priority of Internal Symmetries in Particle Physics." *Studies in History and Philosophy of Modern Physics* 34 (4): 651–75.
- Ladyman, James. 1998. "What is Structural Realism?" *Studies in History and Philosophy of Science* 29: 409–24.
- Ladyman, James, Don Ross, et al. 2007. *Every Thing Must Go: Metaphysics Naturalized*. Oxford: Oxford University Press.
- Laudan, Larry. 1981. "A Confutation of Convergent Realism." *Philosophy of Science* 48 (1): 19–49.

- Locke, John. [1689] 1975. *An Essay Concerning Human Understanding*, ed. Peter H. Nidditch. Oxford: Oxford University Press.
- Maddalena, Giovanni. 2009. “La metafisica della continuità.” in *Metafisica per assurdo: Peirce e i problem dell’epistemologia contemporanea*. Soveria Mannelli, Italy: Rubbettino.
- Michael, Emily. 1974. “Peirce’s Early Study of the Logic of Relations, 1865-1867.” *Transactions of the Charles S. Peirce Society* 10 (2): 63–75.
- Merrill, Daniel D. 1978. “DeMorgan, Peirce and the Logic of Relations.” *Transactions of the Charles S. Peirce Society* 14 (4): 247–84.
- Moore, Matthew E. 2007. “On Peirce’s Discovery of Cantor’s Theorem.” *Cognitio* 8: 223–48.
- . 2011. “Peirce’s Cantor.” in *New Essays on Peirce’s Mathematical Philosophy*, ed. Matthew E. Moore. Chicago: Open Court.
- Morganti, Matteo. 2011. “Is There a Compelling Argument for Ontic Structural Realism?” *Philosophy of Science* 78 (5): 1165–76.
- Muller, Fred A. 2009. “Withering Away, Weakly.” *Synthese* 180 (2): 223–33.
- Myrvold, Wayne C. 1995. “Peirce on Cantor’s Paradox and the Continuum.” *Transactions of the Charles S. Peirce Society* 31 (3): 508–41.
- Peirce, Charles S. 1931–35, 1958. *Collected Papers of Charles Sanders Peirce*, vols. 1–6, eds. Charles Hartshorne & Paul Weiss (1931–35); vols. 7 & 8, ed. Arthur W. Burks (1958). Cambridge: Harvard University Press.
- . 1976. *The New Elements of Mathematics*, 4 vols., ed. Carolyn Eisele Hague: Mouton.
- . 1977. *Semiotic and Significs: The Correspondence Between Charles S. Peirce and Victoria Lady Welby*, ed. Charles S. Hardwick. Bloomington, IN: Indiana University Press.
- . 1982–2009. *Writings of Charles S. Peirce: A Chronological Edition*, ed. Peirce Edition Project. Bloomington, IN: Indiana University Press.
- . 1992. *Reasoning and the Logic of Things: The Cambridge Conferences Lectures of 1898*, ed. Kenneth L. Ketner. Cambridge: Harvard University Press.
- . 1992–98. *The Essential Peirce: Selected Philosophical Writings*, vol. 1, eds. Nathan Houser & Christian Kloesel (1992); vol. 2, ed. Peirce Edition Project (1998). Bloomington, IN: Indiana University Press.
- . 2010. *Philosophy of Mathematics: Selected Writings*, ed. Matthew E. Moore. Bloomington, IN: Indiana University Press.
- Psillos, Stathis. 2012. “Adding Modality to Ontic Structuralism: An Exploration and Critique.” in *Structural Realism: Structure, Object, and Causality*, eds. Elaine M. Landry & Dean P. Rickles. Dordrecht: Springer.

- Ransdell, Joseph M. 1966. *Charles Peirce: The Idea of Representation*. Doctoral Dissertation. Accessed 31 January 2016. <http://www.iupui.edu/~arisbe/menu/library/aboutcsp/ABOUTCSP.HTM>
- Rickles, Dean. 2006. "Time and Structure in Canonical Gravity." in *The Structural Foundations of Quantum Gravity*, eds. Dean Rickles, Steven French, & Juha T. Saatsi. Oxford: Oxford University Press.
- Robin, Richard S. 1967. *Annotated Catalogue of the Papers of Charles S. Peirce*. Cambridge: University of Massachusetts Press.
- Ross, Don. forthcoming. "Will Scientific Philosophy Still Be Philosophy?" *Recherches sur la philosophie et le langage*. Accessed 25 January 2016. http://www.academia.edu/948847/Will_scientific_philosophy_still_be_philosophy
- Short, T. L. 2007. *Peirce's Theory of Signs*. Cambridge: Cambridge University Press.
- Slowik, Edward. 2012. "On Structuralism's Multiple Paths Through Spacetime Theories." *European Journal for Philosophy of Science* 2 (1): 45–66.
- Unger, Roberto Mangabeira & Lee Smolin. 2015. *The Singular Universe and the Reality of Time: A Proposal in Natural Philosophy*. Cambridge: Cambridge University Press.
- Van Fraassen, Bas C. 2006. "Structure: Its Shadow and Substance." *British Journal for the Philosophy of Science* 57 (2): 275–307.
- Worrall, John. 1989. "Structural Realism: The Best of Both Worlds?" *Dialectica* 43: 99–124.
- . 2012. "Miracles and Structural Realism." in *Structural Realism: Structure, Object, and Causality*, eds. Elaine M. Landry & Dean P. Rickles. Dordrecht: Springer.
- Yukawa, Hideki. 1975. *Butsuri Kōgi* (Lectures on Physics). Tōkyō: Kōdansha.
- Zalamea, Fernando. 2012. *Peirce's Logic of Continuity: A Conceptual and Mathematical Approach*. Boston, MA: Docent Press.

CURRICULUM VITAE

Jimmy Jericho Aames

Education

2013: Bachelor of Human Sciences, Osaka University (Japan)

2016: Master of Arts in Philosophy, Indiana University-Purdue University Indianapolis

Honors, Awards, and Fellowships

2015: Jean Martin Maxwell Philosophy Prize

2015–2016: Peirce Edition Project Graduate Assistantship

2016: Michael Burke/John Tilley Grant in Philosophy

2016: Terry Helene Mills Award in Philosophy

2016: Indiana University Bloomington Departmental Fellowship

Research Experience

May 2015–July 2016: Research Assistant at the Peirce Edition Project (Institute for American Thought, IUPUI), writing and editing annotations for the forthcoming Vol. 9 of the *Writings of Charles S. Peirce: A Chronological Edition*, conducting research for material to add to the Peirce Edition Project website, and compiling a chronological catalogue of Peirce's manuscripts.

Papers/Presentations

2013: "Rationalism and Anti-Rationalism Within Hayek's System of Thought: The Significance of the Explanation of the Principle." Undergraduate Thesis, supervised by Dr. Wolfgang Schwentker.

2015: "Peirce's 'Extreme' Realism and Supermultitudinous Conception of Continuity." Paper written for and presented at Dr. André De Tienne's Peirce Seminar.