

Extracting the phase information from atomic memory by intensity correlation measurement

Jinxian Guo,¹ Kai Zhang,¹ L. Q. Chen,^{1,*} Chun-Hua Yuan,¹
Cheng-ling Bian,¹ Z. Y. Ou,^{1,2} and Weiping Zhang^{1,3}

¹Quantum Institute of Atom and Light, State Key Laboratory of Precision Spectroscopy,
Department of Physics, East China Normal University, Shanghai 200062, China

²Department of Physics, Indiana University-Purdue University Indianapolis, 402 North
Blackford Street, Indianapolis, Indiana 46202, USA

³Team Leader

*Lqchen@phy.ecnu.edu.cn

Abstract: We demonstrate experimentally controlled storage and retrieval of the optical phase information in a higher-order interference scheme based on Raman process in ⁸⁷Rb atomic vapor cells. An interference pattern is observed in intensity correlation measurement between the write Stokes field and the delayed read Stokes field as the phase of the Raman write field is scanned. This result implies that the phase information of the Raman write field can be written into the atomic spin wave via Raman process in a high gain regime and subsequently read out via a spin-wave enhanced Raman process, thus achieving optical storage of phase information. This technique should find applications in optical phase image storage, holography and information processing.

© 2015 Optical Society of America

OCIS codes: (020.0020) Atomic and molecular physics; (100.0100) Image processing; (190.0190) Nonlinear optics.

References and links

1. K. Bergmann, H. Theuer, and B. W. Shore, "Coherent population transfer among quantum states of atoms and molecules," *Rev. Mod. Phys.* **70**, 1003–1025 (1998).
2. M. S. Bigelow, N. N. Lepeshkin and R. W. Boyd, "Observation of ultraslow light propagation in a ruby crystal at room temperature," *Phys. Rev. Lett.* **90**, 113903 (2003).
3. M. S. Bigelow, N. N. Lepeshkin and R. W. Boyd, "Superluminal and slow light propagation in a room-temperature solid," *Science* **301**, 200–202 (2003).
4. S. E. Harris, "Electromagnetically induced transparency," *Phys. Today* **50**, 36–42 (1997).
5. C. V. Raman and K. S. Krishnan, "A new type of secondary radiation," *Nature (London)* **121**, 501–502 (1928).
6. V. Boyer, A. M. Marino, R. C. Pooser and P. D. Lett, "Entangled images from four-wave mixing," *Science* **321**, 544–547 (2008).
7. R. M. Camacho, C. J. Broadbent, I. Ali-Khan, and J. C. Howell, "All-Optical delay of images using slow light," *Phys. Rev. Lett.* **98**, 043902 (2007).
8. M. D. Lukin, "Colloquium: trapping and manipulating photon states in atomic ensembles," *Rev. Mod. Phys.* **75**, 457–472 (2003).
9. M. D. Eisaman, A. Andre, F. Massou, M. Fleischhauer, A. S. Zibrov, and M. D. Lukin, "Electromagnetically induced transparency with tunable single-photon pulses," *Nature (London)* **438**, 837–841 (2005).
10. C. W. Chou, S. V. Polyakov, A. Kuzmich, and H. J. Kimble, "Single-photon generation from stored excitation in an atomic ensemble," *Phys. Rev. Lett.* **92**, 213601 (2004).
11. J. L. Le Gouët and P. Berman, "Raman scheme for adjustable-bandwidth quantum memory," *Phys. Rev. A* **80**, 012320 (2009).

12. K. F. Reim, J. Nunn, V. O. Lorenz, B. J. Sussman, K. C. Lee, N. K. Langford, D. Jaksch, and I. A. Walmsley, "Towards high-speed optical quantum memories," *Nat. Photonics* **4**, 218–221 (2010).
13. G. Hétet, J. J. Longdell, M. J. Sellars, P. K. Lam, and B. C. Buchler, "Multimodal properties and dynamics of gradient echo quantum memory," *Phys. Rev. Lett.* **101**, 203601 (2008).
14. A. Uchida, S. Yoshimori, M. Shinozuka, T. Ogawa, and F. Kannari, "Chaotic on-off keying for secure communications," *Opt. Lett.* **26**, 932–934 (2001).
15. C. Gabriel, C. Wittmann, D. Sych, R. Dong, W. Maurer, U. L. Andersen, C. Marquardt, and G. Leuchs, "A generator for unique quantum random numbers based on vacuum states," *Nat. Photonics* **4**, 711–715 (2010).
16. G. Heinze, C. Hubrich and T. Halfmann, "Stopped light and image storage by electromagnetically induced transparency up to the regime of one minute," *Phys. Rev. Lett.* **111**, 033601 (2013).
17. M. Hosseini, B. M. Sparkes, G. Campbell, P. K. Lam, and B. C. Buchler, "High efficiency coherent optical memory with warm rubidium vapour," *Nat. Commun.* **2**, 174 (2011).
18. S. J. Kuo, D. T. Smithey, and M. G. Raymer, "Spatial interference of macroscopic light fields from independent Raman sources," *Phys. Rev. A* **43**, 4083–4086 (1991).
19. L. Q. Chen, C. L. Bian, G. W. Zhang, Z. Y. Ou, and W. P. Zhang, "Observation of temporal beating in first- and second-order intensity measurement between independent Raman Stokes fields in atomic vapor," *Phys. Rev. A* **82**, 033832 (2010).
20. C. L. Bian, L. Q. Chen, G. W. Zhang, Z. Y. Ou, and W. P. Zhang, "Retrieval of phase memory in two independent atomic ensembles by Raman process," *Europhys. Lett.* **97**, 34005 (2012).
21. L. Q. Chen, G. W. Zhang, C. H. Yuan, J. Jing, Z. Y. Ou, and W. P. Zhang, "Enhanced Raman scattering by spatially distributed atomic coherence," *Appl. Phys. Lett.* **95**, 041115 (2009).
22. C. H. Yuan, L. Q. Chen, J. Jing, Z. Y. Ou, and W. P. Zhang, "Coherently enhanced Raman scattering in atomic vapor," *Phys. Rev. A* **82**, 013817 (2010).
23. W. Choi, M. Lee, Y. R. Lee, C. Park, J. H. Lee, and K. An, C. Fang-Yen, R. R. Dasari, and M. S. Feld, "Calibration of second-order correlation functions for nonstationary sources with a multistart, multistop time-to-digital converter," *Rev. Sci. Instrum.* **76**, 083109 (2005).
24. W. C. Su, and C. C. Sun, "Review of random phase encoding in volume holographic storage," *Materials* **5**, 1635–1653 (2012).
25. A. Penzkofer, A. Laubereau, and W. Kaiser, "High intensity Raman interactions," *Prog. Quantum Electron.* **6**, 55–104 (1979).
26. P. J. Bustard, D. Moffatt, R. Lausten, G. Wu, I. A. Walmsley, and B. J. Sussman, "Quantum random bit generation using stimulated Raman scattering," *Opt. Express* **19**, 25173–25180 (2011).
27. J. J. Longdell, E. Fraval, M. J. Sellars, and N. B. Manson, "Stopped light with storage times greater than one second using electromagnetically induced transparency in a solid," *Phys. Rev. Lett.* **95**, 063601 (2005).

1. Introduction

Over the past decade, researchers have developed numerous techniques to control the interaction between matters and light, such as stimulated Raman adiabatic process (STIRAP) [1], coherent population oscillation (CPO) [2, 3], electromagnetically induced transparency (EIT) [4] and Raman process [5]. One of the goals is to achieve quantum memory and quantum storage of light in matters. Among these, electromagnetically induced transparency (EIT) and Raman processes are some of the popular approaches and have been applied widely in holograph, optical imaging [6, 7], remote sensing, and information processing [8–10]. More recently, stimulated Raman processes are employed to achieve broad band quantum storage in atomic ensembles [11–13]. Although these schemes stored complete information of a quantum state of light, sometimes only partial information is needed for storage in some applications. For example, some traditional optical communications [14, 15] only need amplitude information. Furthermore, these schemes generally require two optical fields that satisfy the two-photon resonance condition, leading to an increased degree of complexity.

On the other hand, phase is known as one of the basic quantities related to the coherence property of an optical field. The controlled storage and retrieval of the phase information is essential to many coherent processes such as image storage [16] and gradient echo memory [17], which are related to coherent transfer between light and atomic coherence. Spontaneous Raman process only involves the injected pump laser and is simpler compared to the stimulated Raman process. But the phases of the Stokes fields generated in spontaneous process are random from

one shot to the next [18–20], which prevents us from using the traditional first-order interference method to write and retrieve the phase information. Fortunately, in spontaneous Raman scattering, besides the Stokes field, another field known as the atomic spin wave is also generated simultaneously and there exists a phase anti-correlation between the generated Stokes field and the atomic spin wave [20]. In this paper, we will utilize this phase correlation to observe an interference fringe in intensity correlation measurement that leads to a simple protocol for controlled phase memory and its retrieval using spontaneous Raman process in ^{87}Rb atomic vapor cells.

2. Theory

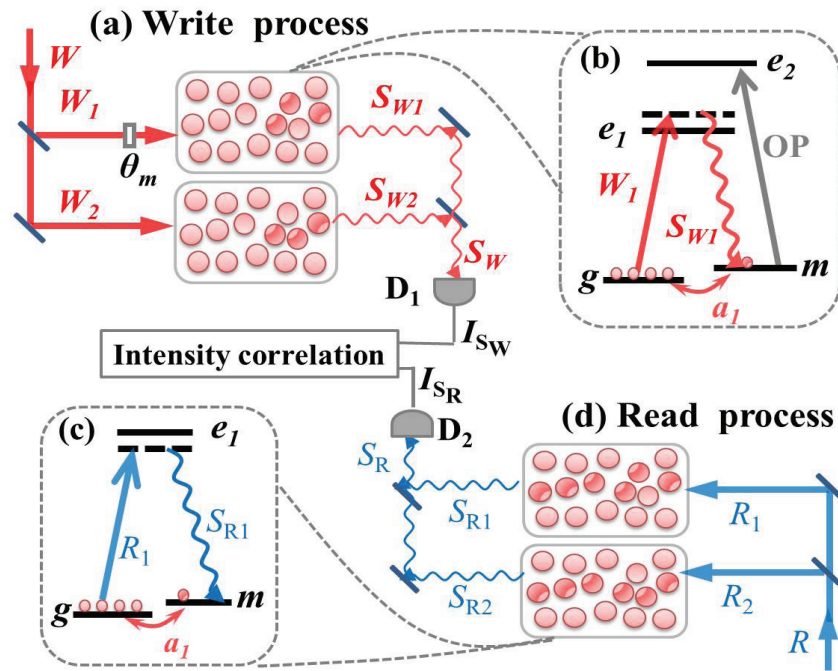

Fig. 1. The schematics for the phase memory: (a) write process and (d) read process. Energy Levels for (b) write and (c) read Raman processes. OP: the optical pumping laser; W and R : the write and read Raman lasers, respectively; S_W and S_R : the generated Stokes signals. a_1 : the atomic spin wave generated in the Raman scattering by the W fields.

Figure 1 shows the schematic diagram of the storage and retrieval processes as well as the energy levels of the ^{87}Rb atoms. The general scheme is similar to that in [20]. The difference lies in the measurement process: we use a second-order intensity correlation method to retrieve the phase information stored in atomic ensemble. Since phase is a relative quantity, we need a second Raman process, denoted by subscript label "2", as a reference. Phase information can be extracted by mixing relevant fields of the two processes. In the protocol shown in Fig. 1, we first write a certain phase (denoted as the memory phase θ_m in Fig. 1(a)) into the atomic ensemble by Raman scattering with W_1 field, and then read out by a method of enhanced Raman scattering [21, 22] with R_1 field. As is well-known, the Raman scattering in ^{87}Rb atoms with a Λ -shaped energy level is a three-wave mixing process involving a write field W , a Stokes field S and a collective atomic spin wave a as shown in Fig. 1(b). In the write process, taking W_1

field for example, the Stokes field starts from the spontaneous emission with an arbitrary phase $\varphi_{S_{W1}}$. Subsequently it is amplified by the stimulated process and the phase $\varphi_{S_{W1}}$ is preserved. The phase φ_{a_1} of the atomic spin wave is correlated to the phase $\varphi_{S_{W1}}$ of the Stokes field with the relation of $\varphi_{a_1} = (\varphi_{W_1} + \theta_m) - \varphi_{S_{W1}}$ [20]. So the Raman scattering of W_1 field can be regarded as the write process: writing the memory phase θ_m into the atomic spin wave a_1 . After the writing process, a read field R is sent into the atomic ensemble. This process is the enhanced Raman scattering [21, 22], taking R_1 field for example, the Stokes field S_{R1} starts from the stimulated emission with the pre-built atomic spin wave a_1 as the seed, the corresponding phase relation is $\varphi_{S_{R1}} = \varphi_{R_1} - \varphi_{a_1}$. So the Raman scattering of R_1 field can be regarded as the read process: reading out the phase information from the previously built atomic spin wave a_1 into S_{R1} field with $\varphi_{S_{R1}} = \varphi_{R_1} - \varphi_{W_1} + \varphi_{S_{W1}} - \theta_m$. However, due to the random characteristic of the phases $\varphi_{S_{W1}}$, we cannot use the first-order interference to retrieve the phase information. On the other hand, second-order intensity correlation measurement between the write Stokes S_W and the read Stokes S_R fields can remove the effect of the random phase φ_{S_W} . Let us demonstrate next with a simple theory how this can be achieved.

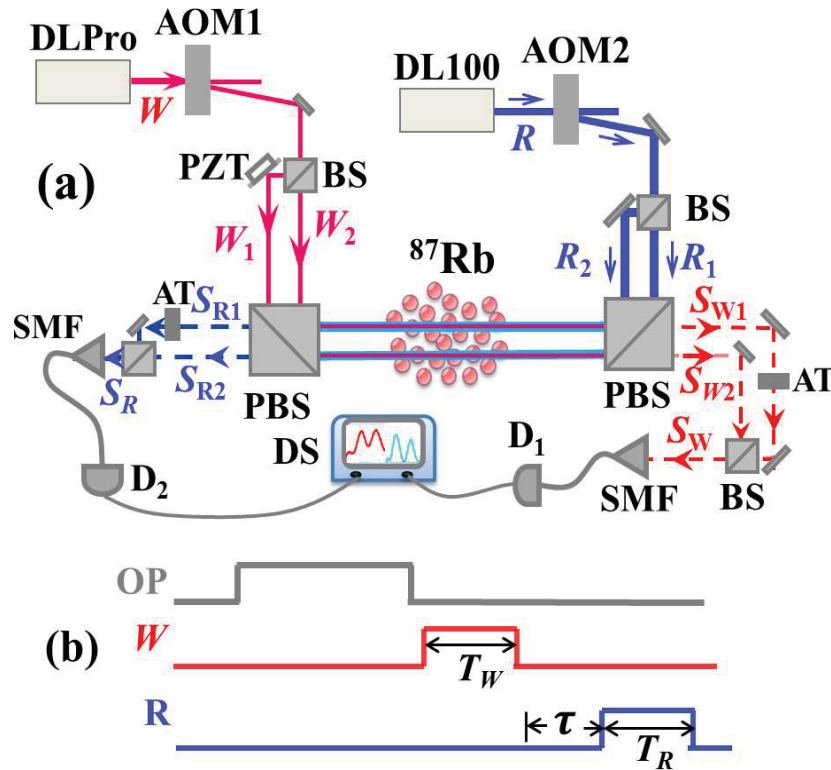

Fig. 2. (a) Experimental setup. AOM: acousto-optic modulator; PZT: piezoelectric transducer; SMF: single mode fiber; PBS: Polarization beam splitter; BS: beam splitter. AT: attenuator. (b) the time sequence, the duration of the OP field is $80\mu\text{s}$.

From [19], we learn that the intensities of the output fields S_W, S_R after mixing have the form of

$$I_{S_W}(t) = A(t)[1 + v_W \cos(\Delta\Omega_W t + \Delta\varphi_{S_W})], \quad (1)$$

$$I_{S_R}(t') = B(t')[1 + v_R \cos(\Delta\Omega_R t' + \Delta\phi_{S_R})], \quad (2)$$

where $t' = t + T + \tau$. T is approximately the duration of the pulses of S_W, S_R . τ is the delay time between the write and read laser pulses, i.e., the memory time. $\Delta\phi_{S_W} = \phi_{S_{W1}} - \phi_{S_{W2}} = \Delta\phi_W - \Delta\phi_a + \theta_m$ and $\Delta\phi_{S_R} = \phi_{S_{R1}} - \phi_{S_{R2}} = \Delta\phi_R - \Delta\phi_a$ [20] with $\Delta\phi_W \equiv \phi_{W1} - \phi_{W2}, \Delta\phi_R \equiv \phi_{R1} - \phi_{R2}, \Delta\phi_a \equiv \phi_{a1} - \phi_{a2}$. Here $\Delta\phi_{S_W}, \Delta\phi_a$ are random but correlated. $\Delta\Omega_W, \Delta\Omega_R$ are related to the powers of W_1, W_2, R_1 and R_2 , due to AC Stark effect. In the experiment, we make $\Delta\Omega_W \approx \Delta\Omega_R$. $A(t), B(t')$ are the temporal profiles of S_{W1} and S_{R1} before mixing respectively. v_W and v_R are the visibility of the beating signals in S_W, S_R and are nearly 1 when the two mixing fields are close in intensity. The intensity correlation function can then be written as [23]

$$\begin{aligned} G^{(2)} &= \langle I_{S_W} I_{S_R} \rangle_T \equiv \frac{1}{T} \int_T dt I_{S_W}(t) I_{S_R}(t') \\ &= \frac{1}{T} \int_T dt A(t) B(t') [1 + v_W \cos(\Delta\Omega_W t + \Delta\phi_{S_W})] \\ &\quad \times [1 + v_R \cos(\Delta\Omega_R t' + \Delta\phi_{S_R})]. \end{aligned} \quad (3)$$

Usually, the beat signal is much faster than the pulse width so that we can approximately pull the slowly varying $A(t)B(t')$ out of the integral:

$$\begin{aligned} G^{(2)} &\approx \langle A(t)B(t') \rangle_T \int_T \frac{dt}{T} [1 + v_W \cos(\Delta\Omega_W t + \Delta\phi_{S_W})] \\ &\quad \times [1 + v_R \cos(\Delta\Omega_R t' + \Delta\phi_{S_R})]. \end{aligned} \quad (4)$$

Since $\Delta\Omega_W \approx \Delta\Omega_R$, we set $T \approx 2\pi n / \Delta\Omega_W \approx 2\pi n / \Delta\Omega_R \approx 4\pi n / (\Delta\Omega_W + \Delta\Omega_R)$ ($n = \text{integer}$). After the expansion, the fast oscillating terms will be averaged to approximately zero and Eq. (4) becomes

$$G^{(2)} \approx \langle A(t)B(t') \rangle_T [1 + \frac{1}{2} v_W v_R \gamma \cos(\Delta\phi_{S_W} - \Delta\phi_{S_R})], \quad (5)$$

with $\gamma \approx \sin \beta / \beta$, $\beta \equiv (\Delta\Omega_W - \Delta\Omega_R)T \sim 0$ due to $\Delta\Omega_W \approx \Delta\Omega_R$.

To eliminate the fluctuations in A, B , we evaluate the normalized intensity correlation function

$$g^{(2)} \equiv G^{(2)} / \langle I_{S_W} \rangle_T \langle I_{S_R} \rangle_T \quad (6)$$

with $\langle I_{S_W} \rangle_T = (1/T) \int_T dt I_{S_W}(t) \approx \int_T dt A(t) / T$ and $\langle I_{S_R} \rangle_T = (1/T) \int_T dt I_{S_R}(t') \approx \int_T dt B(t') / T$. So we have

$$g^{(2)} = g_0^{(2)} [1 + \frac{1}{2} v_W v_R \gamma \cos(\Delta\phi_W - \Delta\phi_R + \theta_m)], \quad (7)$$

where $g_0^{(2)} \equiv \langle A(t)B(t') \rangle_T / \langle A(t) \rangle_T \langle B(t') \rangle_T$, which is the normalized intensity correlation function of the two Stokes fields. Since W_1 and W_2 are derived from a common source, $\Delta\phi_W$ is definite and so is $\Delta\phi_R$. Note that the random phase $\Delta\phi_a$ is cancelled out in Eq. (7). So, we can recover θ_m from the intensity correlation function $g^{(2)}$, thus realize the readout of the phase information.

From Eq. (7), we see that the visibility of the fringes in $g^{(2)}$ is

$$V = \frac{1}{2} v_W v_R \gamma. \quad (8)$$

Because v_W, v_R, γ are limited by 1, the ideal value of visibility is 50% when $v_W, v_R, \gamma \sim 1$. If we consider the decoherence of atomic spin wave [19], the normalized intensity correlation function is

$$g^{(2)} = g_0^{(2)} [1 + V e^{-\zeta \tau} \cos(\Delta\phi_W - \Delta\phi_R + \theta_m)], \quad (9)$$

with ζ as the decay constant.

3. Experiment setup and result

The experimental setup is shown in the Fig. 2. Pure ^{87}Rb atoms are contained in a 75mm long glass cell. The cell is placed inside a four-layer μ -magnetic shielding to reduce stray magnetic fields and is heated up to 75°C using a bifilar resistive heater. The write laser W and the read laser R , detuned from the ^{87}Rb D1 line ($5^2S_{1/2}, F = 1 \rightarrow 5^2P_{1/2}, F' = 2$ transition) by $\Delta_W = 0.8\text{GHz}$ and $\Delta_R = 1\text{GHz}$ respectively, are from two different single-frequency diode lasers operating at 795 nm. The detunings of the write and read are chosen for the optimum overall Raman efficiency: a trade-off between larger Raman interaction and less absorption. W_1 and W_2 fields, which are split from W , co-propagate in parallel through the atomic cell. R_1 and R_2 beams, split from R laser, counter-propagates and overlaps with W_1 and W_2 fields, respectively. The waist of W_1 , W_2 , R_1 and R_2 fields are 0.25mm, 0.28mm, 0.30mm and 0.34mm, respectively. The power of the W_1 , W_2 , R_1 and R_2 are 0.76 mW, 0.98 mW, 0.19 mW and 0.20 mW, respectively. A piezo-electric transducer (PZT) is placed in W_1 route to modulate the phase of the W_1 field. Then we can define this modulation as the memory phase θ_m . All atoms are initially prepared in the ground state $|g\rangle$ by optical pumping (OP). After optical pumping, W and R fields are turned on in a sequence as shown in Fig. 2(b). The write and read fields are chopped into pulses and controlled by acoustic optic modulators (AOM), and the durations of the write and read pulses T_W and T_R are both equal to $1.2\mu\text{s}$. The Stokes fields S_{W1} , S_{W2} , S_{R1} and S_{R2} are produced from W_1 , W_2 , R_1 and R_2 fields, respectively. The S_W field is the combined field of the S_{W1} and S_{W2} and the S_R field is the combined field of S_{R1} and S_{R2} . Since the polarization of the Stokes fields are orthogonal to the corresponding pump lasers, we can separate them with polarization beam splitters (PBS). S_W and S_R fields are coupled into single-mode fibers (SMF) for spatial mode clean-up and detected by photo-detectors D_1 and D_2 and recorded by an oscilloscope.

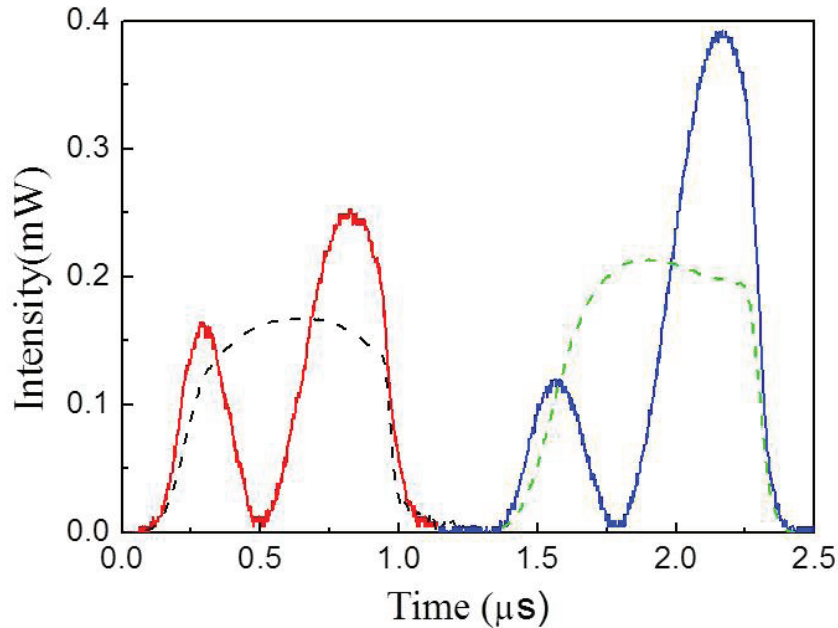

Fig. 3. Temporal behavior of S_W and S_R fields. τ is $0.1\mu\text{s}$. The red line and blue line are the S_W and S_R fields generated in one write-read pulse period. The black dashed curve and green dashed curve are the averaged intensities over 100 pulses of the S_W and S_R fields.

As already observed in [20], the temporal behaviors of S_W and S_R fields for single pulse (solid line) and 100 pulse-average are shown in Fig. 3. Because of the different AC Stark shifts caused by uneven pumping from W_1 and W_2 fields and from R_1 and R_2 fields, both S_W and S_R exhibit beat signals [19]. As seen from Fig. 3, the visibilities v_W, v_R of the beat signals are almost 100% and the beat periods of S_W and S_R are $0.55\mu s$ and $0.59\mu s$, respectively. The corresponding beating frequencies are $1.82MHz$ and $1.69MHz$. These values are adjusted to be the same by the relative intensities of W_1, W_2, R_1, R_2 so that $\beta \ll 1$ and $\gamma \sim 1$ in Eq. (8). The disappearance of the beat signal in multi-pulse average is due to the randomness of $\Delta\phi_{S_W}, \Delta\phi_{S_R}$.

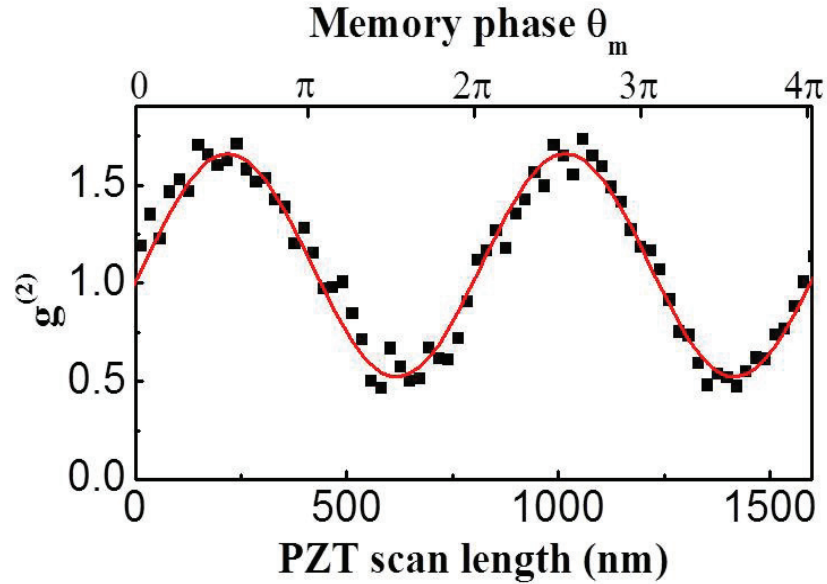

Fig. 4. A sample of $g^{(2)}$ as a function of storage phase θ_m at $\tau = 0.1\mu s$. θ_m is the modulated phase on W_1 , tuned by PZT. The square is the experimental data and the red line is a fit curve to sine-function.

Experimentally, $g^{(2)}$ value is calculated by placing the recorded $I_{S_W}(t)$ and $I_{S_R}(t+T+\tau)$ in Eq. (6). The integration time T is the pulse duration of $T_W = T_R = 1.2\mu s \approx 4\pi/\Delta\Omega_R$. Thus for one record of S_W and S_R shown in Fig. 3, we can obtain one value of $g^{(2)}$. It takes about $100\mu s$ for one measurement. When the phase θ_m is modulated slowly by the PZT, a series of pulses of $I_{S_W}(t)$ and $I_{S_R}(t')$ are measured and the corresponding $g^{(2)}$ values can be obtained as described above.

Figure 4 shows the result of one such scan of the phase θ_m . We plot $g^{(2)}$ values as a function of the phase θ_m . They show an interference pattern with a sine-function fitting to the phase θ_m , which agreed with theoretical prediction given from Eq. (7). There is a phase shift of $\pi/2$ compared with cosine function because of the initial phase $(\Delta\phi_W - \Delta\phi_R)$ in Eq. (7). The best visibility of the interference fringe in Fig. 4 is 43% when the delay time τ between the write and read laser pulses is equal to $0.1\mu s$. This value is smaller than the best theoretical value of 50%. This is due to the slight mismatch between $\Delta\Omega_W$ and $\Delta\Omega_R$, which makes $\gamma < 1$ in Eq. (8). Another consequence of $\Delta\Omega_W \neq \Delta\Omega_R$ is the non-vanishing of the fast oscillating terms in Eq. (4). Since these terms depend on the random phases of $\Delta\phi_{S_W}$ and $\Delta\phi_{S_R}$, the effect is a small

fluctuation in $g^{(2)}$ and its average leads to the reduction of the visibility. A quick estimation based on experimental parameters gives about 5% reduction.

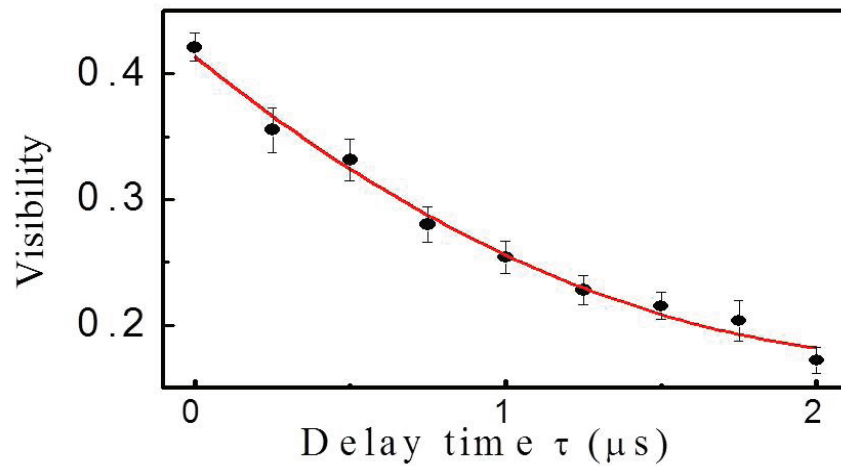

Fig. 5. Interference visibility as a function of delay time between the write and read pulses.

To demonstrate the effect of decoherence of the atomic spin waves on the storage time, we plot in Fig. 3 the visibilities of the interference pattern as a function of the delay times τ . As can be seen, the visibilities drop as the delay times increase and the decay time in Fig. 5 is $2\mu\text{s}$. This is mainly due to the coherent atoms flying out of the region of the read beam, but not the atomic collisions. The dephasing time due to atomic collisions is about several milliseconds under our experimental conditions. The transit time can be calculated by $\tau = r/v_a$, here r is the waist of read field and v_a is the atom's average speed of $300 \sim 400\text{m/s}$ at 75°C . So $\tau \sim 1\mu\text{s}$ in our experiment, it is close to the decay time in Fig. 5.

4. Conclusion

In conclusion, we realized the phase memory experimentally. The memory phase carried by the pump laser is first written into the atomic system by normal Raman process, and then read out by an enhanced Raman process, and finally extracted through second-order intensity correlation measurement between the write and read Stokes signals at two separate paths.

This kind of phase memory technology using spontaneous Raman scattering can be applied in the fields related to the encrypted storage of the optical phase [24]. The randomness in the phase of the spontaneous Raman scattering can be used in the encryption and memory processes. The encrypted information, i.e., the phase of write Stokes field is generated from non-deterministic behavior of atomic system [25]. The intensity correlation measurement can be considered as decryption process. In the experiment, where we use ^{87}Rb atomic vapor to demonstrate our protocol, the bandwidth and memory time are limited by the initial preparation and decoherence time of our atomic system. In future possible practical applications, some other materials are preferred. For example, diamond can provide larger bandwidth of the phase memory [26], and rare-earth-ion-doped crystal can provide longer memory time [27].

Our protocol is somewhat similar to holography in that both require the interference. But the difference is that holography is based on the first-order interference so that the optical loss of the reference and illumination lasers will decrease the image quality. On the other hand, our protocol is the combination of the first-order and second-order interference and the quality is

independent of the loss of the lasers.

Acknowledgments

This work is supported by the National Basic Research Program of China (973 Program Grant No. 2011CB921604), the National Natural Science Foundation of China (grant numbers 11274118, 11129402, 11234003, 11474095 and 11204085) and Supported by Innovation Program of Shanghai Municipal Education Commission (grant no. 13ZZ036), and the Fundamental Research Funds for the Central Universities.