



Review Article

Skeletal loading in animals

A.G. Robling¹, D.B. Burr^{1,2}, C.H. Turner²¹Department of Anatomy & Cell Biology, Indiana University School of Medicine, Indianapolis, USA²Department of Orthopaedic Surgery and Biomechanics & Biomaterials Research Center, Indiana University School of Medicine, Indianapolis, USA

Abstract

A number of *in vivo* skeletal loading models have been developed to test specific hypotheses addressing the key mechanical and biochemical signals involved in bone's adaptive response to loading. Exercise protocols, osteotomy procedures, loading of surgically implanted pins, and force application through the soft tissues are common approaches to alter the mechanical environment of a bone. Although each animal overload model has a number of assets and limitations, models employing extrinsic forces allow greater control of the mechanical environment. Sham controls, for both surgical intervention (when performed) and loading, are required to unequivocally demonstrate that responses to loading are mechanically adaptive. Collectively, extrinsic loading models have fostered a greater understanding of the mechanical signals important for stimulating bone cells, and highlighted the roles of key signaling molecules in the adaptive response.

Keywords: Animal Models, In Vivo Loading, Mechanical Strain, Bone Adaptation, Bone Biomechanics

Introduction

Mechanical loading presents a potent osteogenic stimulus to the skeleton, particularly during adolescence¹. A number of animal models have been designed to test specific hypotheses about bone modeling and remodeling kinetics in response to an enhanced loading environment. These *in vivo* models, each of which has its advantages and limitations, have aided researchers in addressing two fundamental questions concerning the mechanobiology of bone: (1) what mechanical signals elicit a cellular response?; and (2) what cellular events occur in the adaptive response?

Below, we review some of the more widely used *in vivo* mechanical loading models, and consider the strengths and limitations of each for addressing different aspects of bone mechanobiology; special emphasis is given to models employing extrinsic force application. Subsequently, we consider some pivotal information regarding the tissue response to mechanical signals and the biology of mechanotransduction that have been gleaned from *in vivo* loading models.

Corresponding author: A.G. Robling, Ph.D. Department of Anatomy and Cell Biology, Indiana University School of Medicine, 635 Barnhill Dr., MS 5045, Indianapolis, IN 46202, USA. E-mail: arobling@anatomy.iupui.edu

Accepted 25 January 2001

In vivo loading models - design and mechanics

In light of the clear anabolic effects of loading, considerable effort has been invested in elucidating how bone cells perceive and respond to mechanical loading. This process, known as mechanotransduction, comprises four distinct steps: (1) mechanocoupling—conversion of a mechanical force applied to a bone into a local mechanical signal; (2) biochemical coupling—conversion of a local mechanical signal into a biochemical signal and subsequent gene expression; (3) signal transmission—transfer of the response signal, generated in the sensor cell, to the effector cell; and (4) effector cell response—the eventual tissue-level response². Mechanotransduction can be studied using both cell culture techniques and animal loading models. Investigations of mechanocoupling and biochemical coupling are amenable to cell culture experiments, where the cell biology can be well controlled. *In vivo* loading models offer advantages for studies of signal transmission and the effector cell because the relevant cell populations and tissues are present and intact.

Hypotheses formulated to elucidate the mechanobiology of living bone under enhanced mechanical conditions are typically tested by first deforming the bone tissue, for which there are a number of approaches in a living animal. The force required to deform the bone can come from intrinsic sources, such as voluntary muscle contraction during a vigorous exercise session (intrinsic non-invasive models), or

from normal activity following the surgical removal of a nearby bone that formerly shared the load (intrinsic invasive models). Conversely, the load can originate from extrinsic sources, such as loads applied to surgically implanted pins (extrinsic invasive models) or pressure applied to skin adjacent to bone (extrinsic non-invasive models).

Intrinsic loading models

Intrinsic animal loading models are defined as those in which forces imposed on the skeletal element of interest are generated by the animal's own activity. Intrinsic loading models can be classified as non-invasive – which avoid surgical intervention and typically enhance the mechanical environment through an exercise protocol—or invasive, which use the surgical removal of a bone or portion of a bone to enhance the mechanical environment of a nearby surgically undisturbed bone.

Non-invasive (exercise) models

Most laboratory animals can be conditioned to engage in a variety of physical activities, which can alter a number of components of the typical mechanical loading environment (e.g., number of cycles, peak strain magnitudes, rates, and orientations). Many different species have been trained to run on treadmills³⁻⁹ swim in pools^{7,10-12} and jump up to^{13,14} or down from¹⁵ platforms. Additional ambulatory models that do not require animal compliance with a specific exercise protocol have been developed to increase mechanical loading. Rats can be forced to adopt a bipedal posture for brief periods by raising the height of the food tray in their cages¹⁶, or they can be constrained to use three rather than four legs to locomote, by either casting⁵ or bandaging to the body^{17,18} one of the hind limbs, thereby increasing the loads on the functioning hind limb. In addition, centrifugation—rotation of the entire habitat to simulate the effects of increased gravity—can be used to enhance skeletal loading generated from otherwise normal functional activities^{19,20}.

Exercise models have certain advantages over other models for studying mechanical influences on bone physiology. Because they lack surgical intervention, interpretation of the results is not confounded by traumatic or inflammatory responses provided that the exercise regimen is not traumatic. Second, because the loads are derived from muscle contraction and substrate reaction forces, these studies provide a reasonable estimate of what humans could expect to gain in bone mass under similar exercise conditions. Third, unlike most extrinsic loading models, trabecular responses in the limb bone metaphyses can be studied because the muscle and ground reaction forces are transmitted through the joints and underlying epiphyseal/metaphyseal trabeculae^{8,9,11}.

Conversely, a number of limitations are associated with non-invasive ambulatory models. The most obvious drawback to using exercise models is the lack of control over the

mechanical inputs to the bone. Moreover, several reports indicate the same exercise protocol can produce a wide variation in peak strains and strain distributions in different animals within the same experimental (age-matched, weight-matched) group^{4,21,22}. Thus it is extremely difficult to vary independently different components of a mechanical signal in an exercise model; these issues are better suited to extrinsic loading models which allow more precise control of the mechanical environment. Muscle fatigue—an unavoidable consequence of prolonged voluntary exercise—is another confounding factor for maintaining a constant or well-defined mechanical environment in bone. As muscle fatigue develops and the prime movers weaken, peak principal strains can increase significantly and the strain distribution within the cortex can change significantly²³. Consequently, the strain environment produced during the beginning of an exercise session can be quite different from that occurring toward the end (~20 min later) of the session. Additional limitations of the exercise models include 1) the lack of an internal control bone (nonloaded antimer)—running, swimming, jumping, require loading of both right and left limb bones, consequently there is no nonloaded (or normally loaded, in the case of leg casting or bandaging) control bone within the same animal to which the loading response can be compared; and 2) it is difficult to isolate the effects of mechanical loading *per se* as the cause of the adaptive response and exclude those influences/factors related to a general physiological response to exercise. For example, Lieberman²⁴ found that treadmill-exercised pigs and armadillos exhibited thicker and more rigid tibial shafts than sedentary controls, but the exercised animals also had thicker cranial vaults despite the fact that no significant increases in strain were measured in the skull during running.

Invasive (osteotomy) models

An alternative to an exercise protocol for altering the mechanical environment of a bone is the osteotomy procedure. In the forearm of most quadrupedal mammals, both the radius and ulna transmit the weight of the thorax from the distal humerus to the carpus. When one of these elements is removed or resected (typically the ulna), all of the force must be transmitted through the remaining intact bone. In the osteotomized animal, exercise programs are not required (but can be used in conjunction) to elevate strains because normal activities will elicit a greatly enhanced strain environment in the intact bone. Osteotomy experiments have been conducted in a wide range of species, including rats^{25,26}, rabbits²⁷, guinea pigs²⁸, dogs²⁹⁻³², sheep³³, and pigs²¹. The standard site for osteotomy in larger animals is the radius or ulna, though in the rat, the central metatarsals have been overloaded by surgical removal of the peripheral metatarsals^{26,34} or by removing the upper limbs²⁵, which forces the animal to assume a bipedal posture.

Osteotomy is one of the earliest methods developed for altering the strain environment, dating back to the mid 19th

century³⁵. One of the advantages of the osteotomy models is that the procedure can permanently change the strain environment in a bone, so that long-term adaptation of the structural and material properties can be evaluated. For example, Takano et al.³⁶ changed the strain distribution in the cortex of the dog radius via ulnar osteotomy, and showed that the orientation of collagen in new secondary osteons, created in the altered strain fields, is governed by the new strain orientation. This type of investigation is not possible in exercise models, where activity between exercise sessions restores the normal strain environment to the bone. Also, the convergence of structural and material properties following osteotomy allows the investigator to evaluate the "adaptive goal" of the experimental bone under altered mechanical conditions, and compare the result to the control side. Another asset of the osteotomy models is that trabecular bone in the epiphyseal/metaphyseal region can be studied, since the joints of the intact bone must transmit greater loads through the metaphyses and epiphyses³⁴. Further, normal activities can elicit greater strains in the intact bone, thus exercise sessions, conditioning, and training of the animals are not required to enhance the mechanical environment.

Osteotomy models are associated with many of the same limitations described for non-invasive exercise models, particularly the lack of control over mechanical inputs. Another disadvantage to these models, however, is the potentially inflammatory effects of surgical intervention, which can result in injury-induced bone formation³⁷. The osteotomized bone is usually not the same as, but is usually

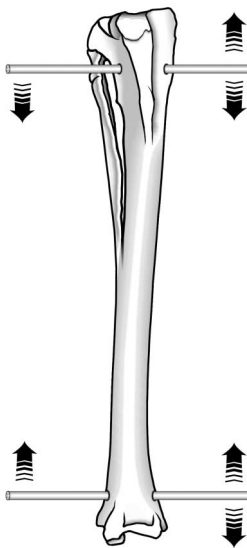

Figure 1. Anterior view of the right tibia from a mature female New Zealand White rabbit, illustrating Heřt's³⁸ preparation for external loading. Rigid Kirschner wires are implanted transcortically through the metaphyses in the mediolateral direction. The tibia can be loaded in axial compression if the two wires are brought together, or in bending if the lateral wire tips are brought together and the medial wire tips are drawn apart. The wires require approximately 30 days to heal in before load is applied.

in close proximity to, the bone later examined histologically. Distinguishing the osteogenic effects of the surgical intervention from those induced by tissue deformation requires proper sham-control animals in which the osteotomy is performed but bone strains in the intact bone are not changed. Although this can be accomplished with fixation plates spanning the excision site, the plate must restore strain magnitudes and orientations to pre-existing values so that only the osteotomy effects—if they exist—are manifest on the intact bone. Another drawback to the osteotomy models is that the experiments typically take much longer to complete; Burr et al.³¹ found that the radius in dogs that had undergone ulnar osteotomy did not exhibit increased strain magnitudes until 1 month after the operation, thus one would expect that the effects of increased strain magnitude would not begin until one month post-surgery. It is also possible that the osteotomy may not change strains sufficiently to elicit an adaptive response³². Finally, these models typically produce woven bone^{21,33}. Although the woven response might be adaptive³¹, humans engaging in vigorous exercise probably do not exhibit a woven bone response. Models invoking lamellar bone formation are better suited to elucidating potential effects of physiologic loading in humans.

Extrinsic loading models

Extrinsic animal loading models are defined as those in which forces imposed on the skeletal element of interest are generated by a mechanical actuator. Extrinsic loading models can be classified as invasive—which use the surgical implantation of pins to transduce the force generated in the actuator to the bone—or non-invasive, which avoid surgical intervention and typically transduce the mechanical signal through the skin and soft tissues.

Invasive (surgical) models

One of the earliest external loading models for studying mechanically-induced bone formation was developed by Hert and colleagues nearly 40 years ago³⁸⁻⁴¹. This model, which continues to be used in recent years⁴²⁻⁴⁴, involves the transcortical implantation of biologically inert Kirschner wires into holes drilled through the proximal and distal tibial metaphyses of anesthetized rabbits (Fig 1). Upon completion of the "healing in" process for the implanted wires (3-4 weeks), well-controlled mechanical signals can be applied to the rigid wires, via Bowden cables, from a number of sources such as an electromagnetic actuator³⁸ or motor-driven cam⁴³. Forces applied to the wires are transmitted directly to the bone, resulting in mediolateral bending (unilateral force application) or axial compression (bilateral force application) of the diaphysis. Histological sections are typically removed from the tibial diaphysis at the midpoint between the two wires. Heřt's transcortical pin design has been adapted to other species, including the sheep^{45,46} and dog^{29,47}.

The pinned rabbit tibia model represents a significant advance in experimental designs for investigating the effects of mechanical loading on bone biodynamics. A major advantage of Heit's model (and of other surgically implanted pin models) is that the mechanical signal generated in the actuator is preserved with great integrity in the bone diaphysis, because the signal travels through very rigid materials rather than through soft tissue and joints, which tend to dampen the signal. This attribute affords the investigator great control over the mechanical environment produced in the tibial diaphysis. Another advantage of the rabbit tibia model is the opportunity to use the contralateral tibia, which is subject to the same systemic (nonmechanical) factors as the loaded limb, as a normally loaded (via habitual cage activity) internal control. Additionally, the model affords the opportunity to study mechanical influences on intracortical remodeling, which is not possible in the more widely used rodent overload models (discussed below), except under very specialized conditions⁴⁸.

The main disadvantage of the rabbit tibia model (and other surgical pin models) is the potentially confounding effects of inflammation from the wire-bone interface during loading, which have not been controlled experimentally. Although the effects of the initial surgery itself appear to be negligible at the midshaft in this and other transcortical pin models⁴⁹⁻⁵², less is known about the potential inflammatory reaction elicited from a very large force, transmitted through the pins, on a very small area of tissue which surrounds the pin. Thus, even after the pins or wires have "healed in" and the investigator is convinced that the response to surgery is negligible, a second inflammatory stimulus can come from the potentially damaging stress concentrations that are generated in the bone tissue surrounding the pins, when external loading is applied to the pins. Inflammatory reaction to tissue damage around the pins could potentially complicate the response measured at midshaft if the effects are severe enough to be manifest down the shaft. This issue has not been addressed in proper sham experiments, but it could if a design similar to the one shown in Fig. 2 were used.

A similar design to Heit's model was adopted by Rubin & Lanyon for studying bone adaptation in the rooster and turkey ulna⁵³, though several important modifications were made. In the avian ulna model, the central 80% of the ulna is detached from the bone ends by sawing through the proximal and distal metaphyseal regions. Stainless steel caps containing unpolymerized methylmethacrylate are then affixed to each end of the functionally isolated ulnar shaft and are held in place by transcortically inserted Steinmann pins that pass through predrilled holes in the caps (Fig 3). One to two days following surgery, the pins (which extrude through the skin) can be secured in the forks of a materials testing machine or other actuator and a well-defined mechanical signal can be transmitted to the ulnar diaphysis through the pins. When not engaged in a loading session, the pins are clamped together so that deformation of the ulnar shaft is prevented. After sacrifice, sections for histology and

microradiography are typically removed from the ulnar diaphysis at the midpoint between the two pins.

The avian ulna model offers many of the same advantages as the rabbit tibia (good signal control and maintenance in tissue, Haversian remodeling), plus a few additional assets. Unlike the tibia model, the contralateral control bone in the avian ulna model is not involved in terrestrial locomotion. Consequently, the potential for enhanced loading in the control limb, which can result from surgically-induced lameness in the pinned limb of quadrupeds, is not an issue in the avian ulna model. Second, because the pins and ulnar shaft are fixed between loading sessions by the clamp, the investigator can be confident that the response observed is the result of the loading regimen only and is not influenced by the potentially variable loads derived from normal cage activity. However, these "background" loads appear to generate a negligible stimulus when compared to those occurring during the loading session²². Third, because the range of mechanical stimulation spans from total disuse (constantly clamped) to overload, this model is the only one that has convincingly demonstrated the inhibition of disuse-induced remodeling caused by dynamic loading.

The limitations of the avian ulna model are also similar to those characteristic of the rabbit tibia model. The modeling response to loading typically comprises woven bone, which

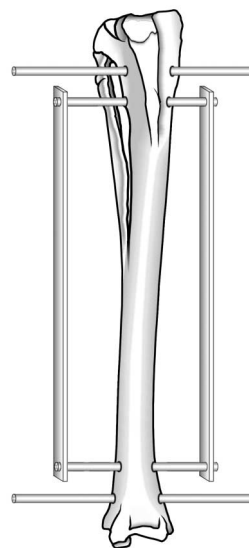

Figure 2. Suggested sham-loading preparation for surgical pin models. Many sham surgery and pinning experiments have been conducted to reveal the effects of the initial surgery (soft tissue incision, periosteal disturbance, cortical drilling, fitting pins) on bone formation at midshaft in this and other pin models. However, the effects of inflammation from the pin-tissue interface during loading have not been addressed. A sham-loading experiment could reveal those effects if force were applied to the loading pins (upper and lower free pins) but deformation of the shaft was prevented (via the central clamped pins) as shown. This sham loading preparation could be used in other surgical pin models as well, to conclusively elucidate potential artifact originating from inflammation at the tissue-implant interface during loading.

contrasts to the lamellar ultrastructure of the pre-existing subperiosteal bone³⁷. Second, functional isolation of the ulna probably creates a disuse condition between loading sessions, which could enhance the sensitivity of the bone cells to mechanical stimulation. Two additional limitations regard the class of animals used: 1) bone modeling and remodeling dynamics in the avian skeleton might be under different evolutionary constraints (skeletal mass for flight) than the terrestrial mammalian skeleton, and 2) the lack of molecular biological probes available for the turkey make it difficult to study the cellular mechanisms of the adaptive response.

More recently, Chambers et al.⁵⁴ developed a surgical model for studying mechanically induced bone formation in the rat 8th caudal vertebra (CV₈). In this model, Steinmann pins are surgically implanted transcortically through the bodies of caudal vertebrae 7 and 9 (Fig 4). Immediately after implantation, the pins are attached to a cam-driven actuator that cyclically draws the two pins together, thereby applying a dynamic compressive load to CV₈. Similar to the turkey ulna preparation, when the rat is not engaged in a loading session, the Steinmann pins are fixed with clamps, which prevents significant deformation of CV₈ between loading sessions.

The primary advantages to the rat tail vertebra model are twofold: 1) the model is well suited for studying mechanical influences on trabecular bone remodeling, and 2) the bone being studied for adaptation (CV₈) is not subjected to surgical manipulation; rather, the two adjacent vertebrae are pierced and pinned, leaving CV₈ undisturbed. Thus, the osteogenic response to loading in CV₈ may be potentially less complicated by traumatic insult from surgery or pin-tissue irritation during loading than in models which use the same bone for surgery/load application and subsequent study. A second advantage to the rat tail model is the availability of rodent molecular probes for studying the cellular mechanisms involved in

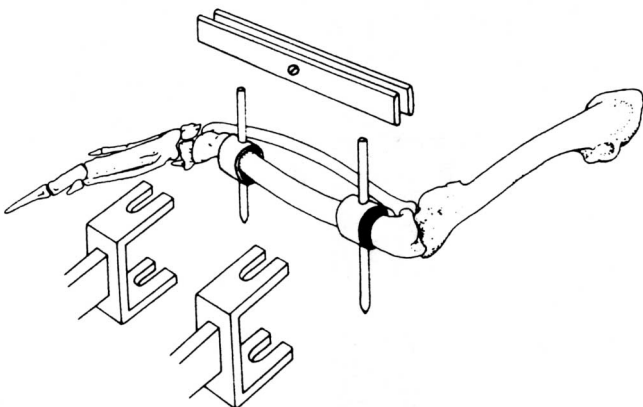

Figure 3. The avian ulna preparation, developed by Rubin and Lanyon⁵³, involves surgical isolation of the ulna at the metaphyses. The ends of the isolated diaphysis are fitted with caps, which are then pierced with Steinmann pins to receive forces generated in the actuator. Between loading sessions, the pins are clamped together to prevent significant deformation of the ulnar shaft. Used with permission from publisher.

mechanotransduction. Further, the forces used in this model elicit an osteogenic response comprising lamellar or parallel-fibered bone on the trabecular envelope, which is a more relevant ultrastructure for drawing inferences to human bone biodynamics. Finally, CV₆ (the vertebra immediately proximal to the proximally pinned vertebra) can be used as an internal control since it receives no loading from the pins⁵⁵.

Although the implantation of the pins into adjacent bones alleviates some of the concern over inflammation/irritation in the bone being studied, it also imposes limitations not found in the other pin models. The mechanical signals generated in the actuator and transmitted to the pins must travel through the intervertebral disks to reach CV₈. The architecture of the disks imparts upon them excellent shock-absorbing properties, which would dampen the signal considerably. A second drawback to the model is that the new periosteal bone formed as a result of loading exhibits a woven architecture, which unlike the avian woven bone, does not remodel into lamellar bone. Additionally, it is unclear whether bones not normally involved in locomotion or significant weight-bearing, such as the tail vertebrae, respond to loading in the same manner or to the same degree as do the limb bones. For example, Rawlinson et al.⁵⁶ showed that osteoblasts derived from the skull are far less sensitive to mechanical deformation than osteoblasts derived from the ulnae of the same animals.

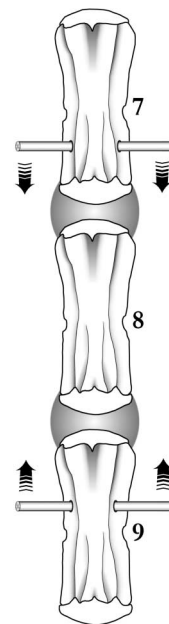

Figure 4. Ventral view of caudal vertebrae 7-9 and intervertebral disks (grey), illustrating Chambers' preparation for external loading of the 8th caudal vertebra (CV₈) in the rat. Pins are inserted through the bodies of CV₇ and CV₉ leaving CV₈ undisturbed. When the pins are brought together by an actuator, axial compressive loads are transmitted to CV₈ through the adjacent disks and vertebrae. Between loading sessions, the pins are clamped together to prevent significant deformation of CV₈. CV₆ (not shown), which receives no load from the actuator, is typically used as a nonloaded control.

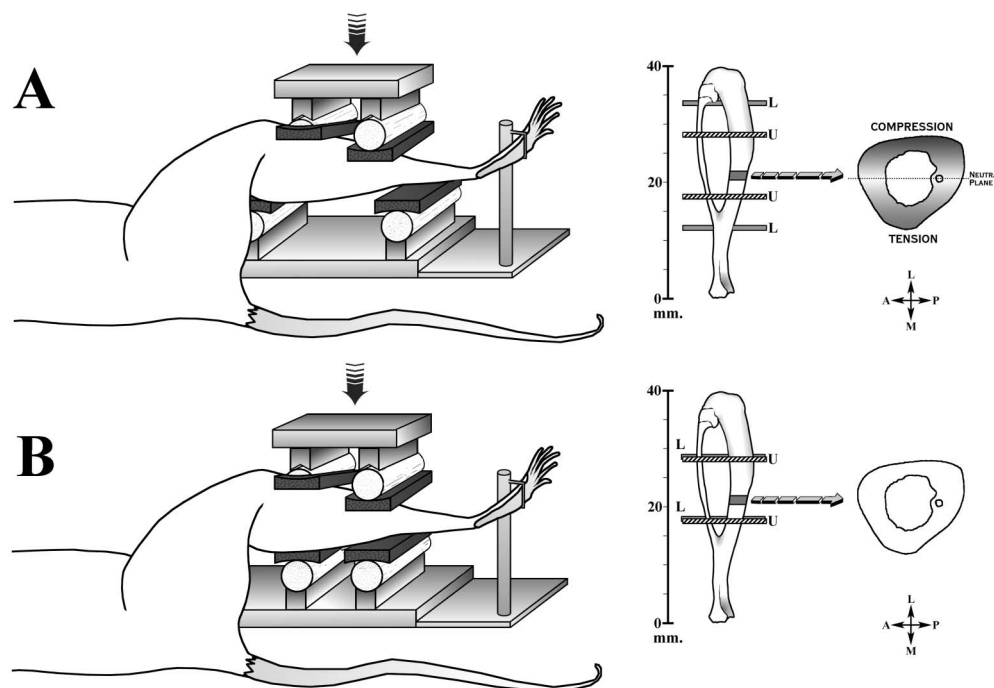

Figure 5. The rat tibia 4-point bending apparatus with the rat *in situ*. (A) When a force is applied to the upper platen of the device, a mediolateral bending moment is produced in the portion of the tibial shaft between the two upper (padded) load points. (B) By moving the lower load points inward, so that they directly oppose the upper points, a force applied to the upper platen will squeeze soft tissues intervening between the bone and the load points, but negligible bending of the shaft occurs. Thus, the sham configuration allows assessment of the effect of soft tissue irritation during loading (and consequent inflammatory response) on bone formation. Reprinted from Robling et al.⁸⁷ with permission from publisher.

Non-invasive models

There is considerable appeal in the development and use of animal loading models that are capable of applying a relatively well-defined mechanical signal to bone, without the potential complications of surgically induced irritation or inflammation. Non-surgical models are technically simpler, less expensive, and do not rely on healing processes, as compared to the surgical models. Turner et al.⁵⁷ described one of the first non-invasive extrinsic loading models, which entailed subjecting the rat tibia to 4-point bending in the mediolateral direction. In this model, which has recently been scaled down for the mouse⁵⁸, the right hind limb of an anesthetized animal is placed between pairs of upper and lower padded load points. For rats, the upper points are spaced 11 mm apart and are centered between the lower load points, which are typically 23 mm apart (Fig 5). The limb is held in proper alignment during the release of force by a foot stirrup. When a downward-directed force is applied to the upper points, the load is transmitted to the tibia through the skin, fascia, muscle, and periosteum intervening between the load points and the bone surface, resulting in the production of a bending moment in the region between the two upper points. The bending moment imposes a compressive strain on the lateral tibial surface and tensile strain on the medial surface⁵⁹. To reveal the osteogenic effects of pressure on the force-transducing soft tissues, a sham

configuration has been implemented in which the upper and lower points directly oppose one another. Using the sham setup, the soft tissues are squeezed just as they are in the bending setup, but the bone does not deform substantially⁶⁰. Thus the sham-bending configuration allows the investigator to evaluate the effects of soft tissue pressure on the osteogenic response. Between loading sessions, rats are permitted normal cage activity, and show no signs of gait modification or lameness from loading. Histological sections are usually removed from the tibial shaft 5-7 mm proximal to the tibia-fibula junction, which approximates the midpoint between the two upper load points.

Beyond its lack of surgical intervention, the rat tibia 4-point bending model offers a number of advantages for studying bone adaptation. This extrinsic loading model is the only one currently in use with a sham loading control. Bending, not sham bending, elicits an osteogenic response on the endocortical surface, which is exclusively lamellar in ultrastructure⁶¹. Second, because the loaded limb is engaged in normal ambulation between loading sessions, the strain histories for the loaded and nonloaded limbs are similar with the exception of the strains generated in the loaded limb during a bending session. Thus, measurements in the nonloaded tibia can be subtracted from those in the loaded tibia to separate the effects of normal ambulation and other systemic factors from responses induced by external loading. Third, as is the case for the rat caudal vertebra model, the rat

tibia model is amenable to cell mechanistic investigations of mechanotransduction, owing to the availability of molecular probes developed for the rat or mouse.

The rat tibia model also has some limitations. First, only the endocortical envelope can be studied; trabecular bone strains at the bone ends are not affected by the loading apparatus, the periosteal surface exhibits artifactual responses, and the Haversian envelope does not exist in the rat under normal circumstances. Second, new bone formation packets on the endocortical surface that result from external loading typically do not exhibit a cement line and therefore reflect modeling dynamics rather than remodeling dynamics, yet remodeling is the dominant physiological activity in adult human bone. This limitation applies to the other rat models as well. Third, unlike the surgical pin models, loading through the soft tissues tends to dampen the mechanical signal, particularly at higher frequencies⁶². Finally, because a non-mechanically adaptive woven bone response is produced on the periosteal surface, investigating mechanically-induced gene expression in harvested periosteal samples or *in situ* is problematic, though endocortical samples and sites would be informative⁶³.

Torrance et al.⁶⁴ introduced an alternative and innovative non-invasive model for studying bone mechanobiology in the rat ulna. Their model involves securing the forearm of an anesthetized rat between two small metal cups – one receiving the elbow and the other receiving the dorsal surface of the volarflexed wrist—which are mounted on the platens of a materials testing machine or other actuator (Fig 6). Compressive forces applied to the platens are transmitted to the ulnar diaphysis through the skin, fascia, articular cartilage (at the distal end), and ulnar metaphyseal bone. The natural curvature of the ulnar diaphysis translates most (~90%) of the axial compression into a mediolateral bending moment. Between loading sessions, rats are permitted normal cage activity, and show no signs of gait modification or lameness from loading. Histological sections can be taken from any point along the length of the diaphysis, though the most robust response to loading appears to be manifest a few millimeters distal to midshaft⁶⁵.

The rat ulna loading model has received wide use in a number of labs because of its ease of use, versatility, and applicability to answering a great range of bone mechanobiological questions. In addition to being conducive to cell biological investigations (probe availability) and its non-surgical approach to loading, the ulnar loading model is the only non-invasive extrinsic loading model in which mechanically induced modeling activity on the periosteal surface can be assessed with great reproducibility. This asset also allows one to examine periosteal gene expression in response to loading, without complications from inflammatory responses⁶⁶. Second, the entire length of the ulnar diaphysis can be studied, allowing the investigator to address whole bone (organ level) adaptation to loading, which can be quite different from the picture painted by a single cross sectional level^{65,67}. In addition, trabecular remodeling in the

metaphyses can be evaluated, though these sites are in close proximity to the tissue-force interface.

The main limitation to the rat ulna loading model is the lack of a sham-loaded control. It is generally assumed that the osteogenic response observed along the ulnar diaphysis is not influenced by trauma or soft tissue pressure, but this has never been tested experimentally. Doing so would require subjecting the elbow and dorsal wrist to the same force vector (magnitude and direction) used during an actual loading session, but at the same time, preventing deformation of the ulnar shaft. In practice, this control would be difficult to devise. Another drawback is that the endocortical surface, at least in the adult rat, does not exhibit detectable loading effects^{65,67,68}. Finally, as is the case in the rat tibia model, the force-transducing soft tissues (tendons and joints in carpus) can attenuate the mechanical signal, creating a significant disparity between the actuator's output and the input received by the ulna⁶².

The rat ulna model is the only non-invasive extrinsic model currently in use that creates a strain distribution similar to that resulting from normal limb usage during locomotion *in vivo*⁶⁵. Although the similarity in strain distribution between artificial and natural loading is an attractive feature of the model, it has its disadvantages in that it is much easier to elicit an osteogenic response in bone when it is deformed in a manner to which it is not accustomed⁶⁹, such as occurs in the rat tibia model and in many of the invasive models. Consequently, experiments

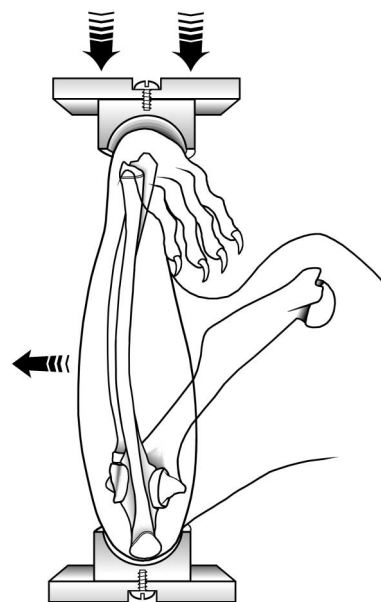

Figure 6. Diagram of the rat ulna loading model. The right distal forelimb is held between upper and lower aluminum cups (shown in hemisection), which are fixed to the loading platens. When force is applied to the upper platen (large arrows), the pre-existing mediolateral curvature of the ulnar diaphysis becomes accentuated and translates most of the axial load into a bending moment (small arrow), which is maximal near the midshaft. Reprinted from Robling et al.⁷¹ with permission from publisher.

employing the rat ulna model must apply ~60-70% of the ultimate force to elicit a robust response. Though these forces do not appear to have adverse effects on joint cartilage in adult animals, growing animals exhibit significantly suppressed longitudinal growth rates at the distal growth plates^{70,71}.

The use of extrinsic loading models to understand bone mechanobiology

Significant advances in our understanding of bone biology—and in other scientific inquiries in general—are established when an experimental observation has both reproducibility and relevance. A phenomenon's reproducibility addresses whether a particular result can be obtained from the same experimental model on different occasions and in different laboratories. Relevance addresses the degree to which a result, obtained using a particular model, reflects the true phenomenon, i.e., the true biology. Relevance can be established if the same process or phenomenon is observed in several different models. Because the extrinsic loading models typically provide much greater control over mechanical parameters, they have been met with much greater consistency in repeated experiments of the same phenomenon (reproducibility) and in similar experiments performed using several different models (reliability) than the intrinsic models. In the following sections, we discuss some of the scientific questions that can be addressed using extrinsic loading models, and highlight the consistency among and within models.

Identification of meaningful mechanical signals

The osteocytic network—which is proposed to sense mechanical information from the matrix and transduce it into a biological message for the effector cells (osteoblasts and osteoclasts)—is likely to be highly sensitive to perturbations in its surrounding mechanical environment⁷². However, each physical perturbation experienced by the matrix is associated with many individual "pieces" of mechanical information (e.g., strain orientation, direction, frequency, energy density, to name a few), so that cells are inundated with a host of mechanical signals over time and space. However, most of these signals are ignored, so that relatively few will induce a response in the sensor cells⁷³. To elucidate the components that are processed (and those that are ignored) by bone cells, considerable effort has been spent on decomposing applied loading regimens into their constituent elements, and investigating their effects individually (when possible) on mechanically-induced bone formation. Animal overload models, particularly the extrinsic loading models, have had a pivotal role in sorting through the mechanical signals to which bone responds.

One of the earliest investigations addressing a specific component of the mechanical signal was Heit's experiments on the effects of continuous versus intermittent bending of

the rabbit tibia⁴¹. After loading growing and mature rabbit tibiae continuously for periods lasting several weeks to over one year, they found that static loading failed to elicit an osteogenic response on the endocortical or periosteal surfaces of the tibia. Dynamic loading, however, provided a potent osteogenic stimulus on both surfaces³⁹. The failure of static loading to enhance bone formation has been demonstrated in the pinned rabbit tibia model⁴¹, the avian ulna model⁷⁴, the rat tibia model⁷⁵, and the rat ulna model⁷¹. These models have also yielded results showing that dynamic loading is a powerful stimulus for bone formation.

If one considers that static and dynamic loading protocols reside on opposite ends of the same frequency spectrum, an obvious question arises: at what frequency must load be applied for the cells to consider the signal dynamic rather than static? Turner et al.⁷⁶ used the rat tibia 4-point bending model to address this issue by applying 36 cycles per day to 6 groups of rats, which differed only in the frequency of the applied load. Rats loaded at a frequency of 0.05 (1 cycle every 20 seconds), 0.1, or 0.2 Hz failed to exhibit an increase in relative (loaded minus nonloaded limb) bone formation rate (rBFR). Groups loaded at frequencies exceeding 0.2 Hz (0.5, 1.0, and 2.0 Hz) exhibited significantly greater rBFR than controls. Thus, loading need not be purely static to be ineffective; dynamic signals at low enough frequencies are processed by the cells as static loads.

Once the minimum frequency required to elicit an osteogenic response is exceeded, bone formation increases in a dose-dependent manner as a function of loading frequency. Using the avian ulna model, Rubin & McLeod⁷⁷ showed that bone formation (ingrowth into a porous coated implant) was proportional to the frequency of the applied strain in the 1 to 20 Hz range. Interestingly, this model has also revealed that higher frequency signals appear capable of generating an osteogenic response at strain magnitudes (~150 $\mu\epsilon$) once thought to be insufficient for stimulating bone formation⁷⁸. Hsieh & Turner⁶⁸ found a similar dose response between load frequency and bone formation using the rat ulna loading model.

The rate of load application is another important component of a mechanical stimulus, as demonstrated by at least three independent *in vivo* loading models. Using a surgically pinned sheep radius, O'Connor et al.⁴⁵ reported a significant correlation between bone formation and strain rate. In the rat tibia model, Turner et al.⁷⁵ showed that the osteogenic response was proportional to strain rate when peak strain magnitude and frequency were held constant. Later, Mosley & Lanyon⁷⁹ confirmed in the rat ulna model the significance of strain rate as a controlling factor in mechanically-induced bone formation. The data generated from these *in vivo* models regarding the osteogenic effects of high strain/load rates support clinical observations attesting to the greater effectiveness of high-impact exercise for improving bone mass, when compared to low-impact exercise^{80,81}.

It should be noted that the role of strain magnitude in

the osteogenic response to loading has been investigated explicitly in several models, each of which has confirmed the anabolic potency of high-magnitude strains^{61,64,65,82,83}. However, the effects of strain magnitude cannot be completely uncoupled from the effects of strain rate or frequency. When frequency is held constant, increasing the strain magnitude necessarily increases the strain rate; when strain rate is held constant, increasing the strain magnitude changes the strain frequency spectrum⁸⁴.

It is clear that bone responds to mechanical stimuli when the signal contains the appropriate components. But bone cells can ignore otherwise osteogenic mechanical inputs if the animal is of advanced age, or if the bone cells are temporarily desensitized. Reduced responsiveness with senescence has been demonstrated in the rat tibia model⁸⁵ and in the avian ulna model⁸⁶. Regarding the temporary loss of sensitivity in younger, healthy bone, experiments performed using the avian ulna model⁵³, the rat jumping model¹⁴, the rat tibia 4-point bending model⁷⁶, and the rat caudal vertebra model⁸³ all highlight the potential to saturate the osteogenic response to mechanical loading, i.e., bone formation can plateau within a single loading bout. Once cells have been maximally stimulated, they require a load-free recovery period to restore mechanosensitivity^{73,87}. Mechanical stimuli applied to mechanically saturated cells that have not been allotted time to regain mechanosensitivity will elicit either no osteogenic response or a suboptimal response^{87,88}.

Cellular response to relevant mechanical signals

In addition to questions of relevant mechanical signals, there is perhaps a greater biomedical interest in understanding sequences of molecular events occurring after the bone cell network receives a meaningful, and ultimately osteogenic, mechanical signal. Changes in cell architecture, gene transcription, ion channel activity, and catalysis of signaling molecules (among others) occur in mechanically stimulated bone cells, but a detailed understanding of the mechanotransduction pathway(s) remains to be determined. Identification of the genes upregulated or downregulated as a result of mechanical stimulation, for example, could be used as pharmaceutical targets for enhancing bone mass through the mechanotransduction pathways, without ever having to apply a mechanical stimulus to the bone. This would be of particular value for individuals in whom initiation of an exercise program would pose significant risk for fracture in an already fragile skeleton.

Once the sensor cells detect a physiologically meaningful mechanical signal, the nature of the signal must change from a mechanical form to a chemical form, so that the effector cells (which are some distance away) can be signaled via messenger molecules to adjust the bone structure². The extrinsic loading models have revealed important molecules involved in the sequence of events leading to mechanically-induced bone formation. Moreover, detection of changes in gene expression resulting from *in vivo* loading (see below) have

provided clues, or starting points, for the investigation of molecular mechanisms that can be more easily addressed in culture.

The role of prostaglandins as important signaling molecules in mechanotransduction and osteogenesis has been demonstrated in at least three extrinsic loading models. Using the pinned avian ulna model, Pead and Lanyon⁸⁹ showed that blocking the activity of cyclooxygenase (COX)—a key enzyme in the synthesis of prostaglandins—via administration of indomethacin several hours before loading, resulted in a significantly suppressed osteogenic response on the periosteal surface when compared to pinned, nonloaded animals administered vehicle alone. Forwood⁹⁰ used the rat tibia 4-point bending model to investigate the effects of suppressing COX-2 activity on load-induced endocortical bone formation. Two inhibitors were used—NS 398 (which selectively blocks activity of the inducible isoform [COX-2]) and indomethacin (which inhibits both constitutive [COX-1] and inducible isoforms)—each of which significantly suppressed endocortical bone formation rates when compared to loaded animals administered vehicle alone. Additionally, tissue sections from rat tibiae subjected to 4-point bending showed strong immunostaining for COX-2 in osteocytes immediately after application of load, whereas detection of COX-2 in sections from the nonloaded limb was minimal⁹¹. Chow & Chambers⁹² demonstrated the effects of COX inhibition on the trabecular envelope using the rat caudal vertebra model. They reported complete inhibition of mechanically-induced cancellous bone formation (not significantly different from pinned nonloaded animals) when rats were administered indomethacin several hours before load application. The action of prostaglandins as important paracrine and autocrine signaling molecules in mechanotransduction relies on the presence of prostaglandin receptors (EP-1 to EP-4) on the cell surface. Recent experiments performed using the tibia 4-point bending model have indicated that both EP-1 and EP-2 might be involved in mechanotransduction^{93,94}. The roles of the remaining prostaglandin receptors in mechanotransduction have yet to be reported.

Nitric oxide (NO) has been identified as an important signaling molecule in bone mechanotransduction⁹⁵, and several models have confirmed its role in the adaptive response *in vivo*. Fox et al.⁹⁶ used the rat caudal vertebra model to investigate the effects of suppressing nitric oxide synthase (NOS)—a key enzyme for NO synthesis—on the osteogenic response to loading. Administration of a competitive inhibitor of NOS, NG-monomethyl-L-arginine (L-NMMA), shortly before a loading bout completely abolished the mechanically-induced response seen in rats given vehicle alone before loading. The rat tibia 4-point bending model has yielded similar results regarding the role of NO in mechanically-induced bone formation. Turner et al.⁹⁷ showed that the inhibition of NOS with N^G-nitro-L-arginine methyl ester (L-NAME) shortly before tibial bending significantly suppressed bone formation rates on the endocortical surface when compared to non-treated controls.

Time after loading	Effects	References
30 to 60 min	Increased expression of early response genes, specifically in osteocytes and bone lining cells	104-106
6 to 12 hr	Increased expression of growth factors in osteocytes and periosteal cells; increased expression of heme oxygenases and tenascin-C in bone cells	107-110
24 hr	Increased expression of matrix proteins, such as type I collagen and osteopontin	63, 107
48 hr	Appearance of active osteoblasts on trabecular and endocortical surfaces, probably originating from bone lining cells or committed precursors. Appearance of osteoblasts on the periosteal surface	111-113
72 hr	Peak expression of type I collagen	107
96 hr	Appearance of osteoblasts originating from proliferating precursors	112

Table 1. Mechanical loading effects on gene expression and cell populations in bone.

Loading models in genetics

The recently identified "high bone mass" mouse presents an interesting animal model for studying the genetic influences on bone mass, and possibly may facilitate the identification of a mechanosensitivity gene(s). Compared to "low bone mass" mice (C57BL/6J or B6 strain), the high bone mass C3H/HeJ (C3H) strain has 48% more femoral bone mineral⁹⁸, yet the long bones of C3H mice are largely unresponsive to mechanical loading. Using the non-invasive tibia bending model, Akhter et al.⁵⁸ demonstrated that the C3H mouse tibia was far less responsive to mechanical loading when compared to the tibia of B6 mice, even though strain magnitudes engendered in the bone were similar. These results were affirmed in C3H and B6 mice subjected to jumping exercise¹³.

Genomic approaches for *in vivo* bone loading models

Loading models have proven useful for uncovering new genes involved in bone formation. Gene expression by bone cells after mechanical loading *in vivo* can be determined using Northern blot or cDNA array analyses (of extracted mRNA) or *in situ* hybridization techniques. Using differential display polymerase chain reaction, Noel et al.⁹⁹ uncovered a novel gene that was upregulated by mechanical loading using the rat caudal vertebra loading model. This gene, which they called RoBo-1, is also upregulated in the rat ulna loading model⁹⁹. Mason et al.¹⁰⁰ identified what appeared to be a novel gene, which was downregulated by mechanical loading in the rat ulna. They subsequently found that this gene was highly homologous to a neuronal glutamate/aspartate transporter not previously observed in bone cells. This discovery demonstrated that neurotransmitters might act as paracrines in bone, and thus opened a new avenue for research in bone

biology¹⁰¹. The sequence of biological events following loading has been described in several *in vivo* loading models. The genes expressed and cell types responding vary with time after loading (Table 1). It is often desirable to isolate specific cell populations from bone tissue for RNA extraction. For instance, the periosteum can be dissected away to isolate periosteal cells¹⁰², or osteocytes and other cells within cortical bone can be separated from bone lining cells by sequential cuts using a cryostat¹⁰³. With efforts under way to sequence the mouse and rat genomes, powerful new genetic tools are just around the corner. The application of genomic tools to *in vivo* loading models will undoubtedly lead to new biological insights.

Conclusions

The *in vivo* overload models developed over the past 30 years have allowed investigators to test a wide range of hypotheses addressing the mechanobiology of bone. Extrinsic loading models have been particularly useful in these endeavors in light of their reliability and relevance. Each model has a number of assets and limitations, all of which should be taken into account when designing experiments to test specific hypotheses. Where some models have shortcomings for addressing a particular question, others are well suited; there is no single overload model that is optimal for all investigations. The model used for any experiment should be based on consideration of the limitations of each model. Continued development and refinement of models that will allow more stringent controls, in conjunction with the explosive growth of transgenic animal technology, will undoubtedly lead to a more comprehensive understanding of the process of mechanically-induced bone formation.

References

1. Kannus P, Haapasalo H, Sankelo M, Sievanen H, Pasanen M, Heinonen A, Oja P, Vuori I. Effect of starting age of physical activity on bone mass in the dominant arm of tennis and squash players. *Ann Intern Med* 1995; 123:27-31.
2. Duncan RL, Turner CH. Mechanotransduction and the functional response of bone to mechanical strain. *Calcif Tissue Int* 1995; 57:344-58.
3. Woo SL, Kuei SC, Amiel D, Gomez MA, Hayes WC, White FC, Akeson WH. The effect of prolonged physical training on the properties of long bone: a study of Wolff's Law. *J Bone Joint Surg [Am]* 1981; 63:780-7.
4. Loitz BJ, Zernicke RF. Strenuous exercise-induced remodelling of mature bone: relationships between in vivo strains and bone mechanics. *J Exp Biol* 1992; 170:1-18.
5. Steinberg ME, Trueta J. Effects of activity on bone growth and development in the rat. *Clin Orthop* 1981; 156:52-60.
6. McCarthy RN, Jeffcott LB. Effects of treadmill exercise on cortical bone in the third metacarpus of young horses. *Res Vet Sci* 1992; 52:28-37.
7. Snyder A, Zierath JR, Hawley JA, Sleeper MD, Craig BW. The effects of exercise mode, swimming vs. running, upon bone growth in the rapidly growing female rat. *Mech Ageing Dev* 1992; 66:59-69.
8. Bourrin S, Genty C, Palle S, Gharib C, Alexandre C. Adverse effects of strenuous exercise: a densitometric and histomorphometric study in the rat. *J Appl Physiol* 1994; 76:1999-2005.
9. Bourrin S, Palle S, Pupier R, Vico L, Alexandre C. Effect of physical training on bone adaptation in three zones of the rat tibia. *J Bone Miner Res* 1995; 10:1745-52.
10. Swissa-Sivan A, Simkin A, Leichter I, Nyska A, Nyska M, Statter M, Bivas A, Menczel J, Samueloff S. Effect of swimming on bone growth and development in young rats. *Bone Miner* 1989; 7:91-105.
11. Bourrin S, Ghaemmaghami F, Vico L, Chappard D, Gharib C, Alexandre C. Effect of a five-week swimming program on rat bone: a histomorphometric study. *Calcif Tissue Int* 1992; 51:137-42.
12. Simkin A, Leichter I, Swissa A, Samueloff S. The effect of swimming activity on bone architecture in growing rats. *J Biomech* 1989; 22:845-51.
13. Kodama Y, Umemura Y, Nagasawa S, Beamer WG, Donahue LR, Rosen CR, Baylink DJ, Farley JR. Exercise and mechanical loading increase periosteal bone formation and whole bone strength in C57BL/6J mice but not in C3H/HeJ mice. *Calcif Tissue Int* 2000; 66:298-306.
14. Umemura Y, Ishiko T, Yamauchi T, Kurono M, Mashiko S. Five jumps per day increase bone mass and breaking force in rats. *J Bone Miner Res* 1997; 12:1480-5.
15. Judex S, Zernicke RF. High-impact exercise and growing bone: relation between high strain rates and enhanced bone formation. *J Appl Physiol* 2000; 88:2183-91.
16. Yao W, Jee WSS, Chen J, Liu H, Tam CS, Cui L, Zhou H, Setterberg RB, Frost HM. Making rats rise to erect bipedal stance for feeding partially prevented orchidectomy-induced bone loss and added bone to intact rats. *J Bone Miner Res* 2000; 15:1158-68.
17. Jee WS, Li XJ. Adaptation of cancellous bone to overloading in the adult rat: a single photon absorptiometry and histomorphometry study. *Anat Rec* 1990; 227:418-26.
18. Jee WS, Li XJ, Schaffler MB. Adaptation of diaphyseal structure with aging and increased mechanical usage in the adult rat: a histomorphometrical and biomechanical study. *Anat Rec* 1991; 230:332-8.
19. Smith SD. Effects of long-term rotation and hypergravity on developing rat femurs. *Aviat Space Environ Med* 1975; 46:248-53.
20. Wunder CC, Stanley RB, Kral M, Skaugstad C. Growth of mouse femurs during continual centrifugation. *Nature* 1960; 188:151-2.
21. Goodship AE, Lanyon LE, McFie H. Functional adaptation of bone to increased stress. An experimental study. *J Bone Joint Surg [Am]* 1979; 61:539-46.
22. Konieczynski DD, Truty MJ, Biewener AA. Evaluation of a bone's in vivo 24-hour loading history for physical exercise compared with background loading. *J Orthop Res* 1998; 16:29-37.
23. Yoshikawa T, Mori S, Santiesteban AJ, Sun TC, Hafstad E, Chen J, Burr DB. The effects of muscle fatigue on bone strain. *J Exp Biol* 1994; 188:217-33.
24. Lieberman DE. How and why humans grow thin skulls: experimental evidence for systemic cortical robusticity. *Am J Phys Anthropol* 1996; 101:217-36.
25. Riesenfeld A. Metatarsal robusticity in bipedal rats. *Am J Phys Anthropol* 1972; 36:229-33.
26. Riesenfeld A. Changes in metatarsal robusticity following experimental surgery. *Am J Phys Anthropol* 1974; 40:205-11.
27. Wermel J. Untersuchungen über die kinetogen und ihre bedeutung in der onto-und phylogenetischen entwicklung (Experimente und vergleichungen an wirbeltierextremitäten). *Veränderungen der dicke und der masses der knochen. Morphologica Jahrbuch* 1935; 75:92-127.
28. Hille E, Schulitz KP, Gipperich J, Dettmann B. Experimental stress-induced changes in growing long bones. *Int Orthop* 1988; 12:309-15.
29. Chamay A, Tschantz P. Mechanical influences in bone remodeling. Experimental research on Wolff's law. *J Biomech* 1972; 5:173-80.
30. Burr DB, Schaffler MB, Yang KH, Wu DD, Lukoschek M, Kandzari D, Sivaneri N, Blaha JD, Radin EL. The effects of altered strain environments on bone tissue kinetics. *Bone* 1989; 10:215-21.
31. Burr DB, Schaffler MB, Yang KH, Lukoschek M, Sivaneri N, Blaha JD, Radin EL. Skeletal change in response to altered strain environments: is woven bone a response to elevated strain? *Bone* 1989; 10:223-33.

32. Carter DR, Harris WH, Vasu R, Caler WE. The mechanical and biological response of cortical bone to in vivo strain histories. In: Cowin SC (ed) *Mechanical Properties of Bone*. New York, 1981:81-92.
33. Lanyon LE, Goodship AE, Pye CJ, MacFie JH. Mechanically adaptive bone remodeling. *J Biomech* 1982; 15:141-54.
34. Simon MR. The effect of dynamic loading on the growth of epiphyseal cartilage in the rat. *Acta Anat* 1978; 102:176-83.
35. Sedillot MC. De l'influence des causes mecaniques sur la forme et le developpement des os; moulage de ces organes par des matieres solidifiables injectees dans leur gaine periostee. *Comptes Rendus de l'Academie des Sciences* 1865; 60:97-100.
36. Takano Y, Turner CH, Owan I, Martin RB, Lau ST, Forwood MR, Burr DB. Elastic anisotropy and collagen orientation of osteonal bone are dependent on the mechanical strain distribution. *J Orthop Res* 1999; 17:59-66.
37. Bertram JE, Swartz SM. The "law of bone transformation": a case of crying Wolf? *Biol Rev Camb Philos Soc* 1991; 66:245-73.
38. Heřt J, Lišková M, Landa J. Reaction of bone to mechanical stimuli. 1. Continuous and intermittent loading of tibia in rabbit. *Folia Morphol (Praha)* 1971; 19:290-300.
39. Lišková M, Heřt J. Reaction of bone to mechanical stimuli. 2. Periosteal and endosteal reaction of tibial diaphysis in rabbit to intermittent loading. *Folia Morphol* 1971; 19:301-17.
40. Heřt J, Pribylova E, Lišková M. Reaction of bone to mechanical stimuli. 3. Microstructure of compact bone of rabbit tibia after intermittent loading. *Acta Anat* 1972; 82:218-30.
41. Heřt J, Lišková M, Landrgot B. Influence of the long-term, continuous bending on the bone. An experimental study on the tibia of the rabbit. *Folia Morphol* 1969; 17:389-99.
42. McDonald F, Pitt Ford TR. Blood flow changes in the tibia during external loading. *J Orthop Res* 1993; 11:36-48.
43. McDonald F, Yettram AL, MacLeod K. The response of bone to external loading regimens. *Med Eng Phys* 1994; 16:384-97.
44. McDonald F, Pitt Ford TR. The effect of blood flow on the material properties of bone. *Ann Biomed Eng* 1994; 22:194-201.
45. O'Connor JA, Lanyon LE, MacFie H. The influence of strain rate on adaptive bone remodeling. *J Biomech* 1982; 15:767-81.
46. Churches AE, Howlett CR. Functional adaptation of bone in response to sinusoidally varying controlled compressive loading of the ovine metacarpus. *Clin Orthop* 1982; 168:265-280.
47. Meade JB, Cowin SC, Klawitter JJ, Van Buskirk WC, Skinner HB. Bone remodeling due to continuously applied loads. *Calcif Tissue Int* 1984; 36:S25-30.
48. Bentolila V, Boyce TM, Fyhrie DP, Drumb R, Skerry TM, Schaffler MB. Intracortical remodeling in adult rat long bones after fatigue loading. *Bone* 1998; 23:275-81.
49. Churches AE, Howlett CR, Ward GW. Bone reaction to surgical drilling and pinning. *J Biomech* 1980; 13:203-9.
50. Goransson H, Patiala H, Linden M, Vuola J, Rokkanen P. Histology and histomorphometry of bone regeneration after experimental injuries. *Ann Chir Gynaecol* 1992; 81:58-65.
51. Caron JP, Barber SM, Doige CE, Pharr JW. The radiographic and histologic appearance of controlled surgical manipulation of the equine periosteum. *Vet Surg* 1987; 16:13-20.
52. Barro WB, Latham RA. Palatal periosteal response to surgical trauma. *Plast Reconstr Surg* 1981; 67:6-16.
53. Rubin CT, Lanyon LE. Regulation of bone formation by applied dynamic loads. *J Bone Joint Surg [Am]* 1984; 66:397-402.
54. Chambers TJ, Evans M, Gardner TN, Turner-Smith A, Chow JW. Induction of bone formation in rat tail vertebrae by mechanical loading. *Bone Miner* 1993; 20:167-78.
55. Chow JW, Fox S, Jagger CJ, Chambers TJ. Role for parathyroid hormone in mechanical responsiveness of rat bone. *Am J Physiol* 1998; 274:E146-54.
56. Rawlinson SC, Mosley JR, Suswillo RF, Pitsillides AA, Lanyon LE. Calvarial and limb bone cells in organ and monolayer culture do not show the same early responses to dynamic mechanical strain. *J Bone Miner Res* 1995; 10:1225-32.
57. Turner CH, Akhter MP, Raab DM, Kimmel DB, Recker RR. A non-invasive, *in vivo* model for studying strain adaptive bone modeling. *Bone* 1991; 12:73-9.
58. Akhter MP, Cullen DM, Pedersen EA, Kimmel DB, Recker RR. Bone response to in vivo mechanical loading in two breeds of mice. *Calcif Tissue Int* 1998; 63:442-9.
59. Akhter MP, Raab DM, Turner CH, Kimmel DB, Recker RR. Characterization of in vivo strain in the rat tibia during external application of a four-point bending load. *J Biomech* 1992; 25:1241-6.
60. Raab-Cullen DM, Akhter MP, Kimmel DB, Recker RR. Periosteal bone formation stimulated by externally induced bending strains. *J Bone Miner Res* 1994; 9:1143-52.
61. Turner CH, Forwood MR, Rho JY, Yoshikawa T. Mechanical loading thresholds for lamellar and woven bone formation. *J Bone Miner Res* 1994; 9:87-97.
62. Hsieh YF, Wang T, Turner CH. Viscoelastic response of the rat loading model: implications for studies of strain-adaptive bone formation. *Bone* 1999; 25:379-82.
63. Miles RR, Turner CH, Santerre R, Tu Y, McClelland P, Argot J, DeHoff BS, Mundy CW, Rosteck PR, Jr., Bidwell J, Sluka JP, Hock J, Onyia JE. Analysis of differential gene expression in rat tibia after an osteogenic

- stimulus *in vivo*: mechanical loading regulates osteopontin and myeloperoxidase. *J Cell Biochem* 1998; 68:355-65.
64. Torrance AG, Mosley JR, Suswillo RF, Lanyon LE. Non-invasive loading of the rat ulna *in vivo* induces a strain-related modeling response uncomplicated by trauma or periosteal pressure. *Calcif Tissue Int* 1994; 54:241-7.
 65. Mosley JR, March BM, Lynch J, Lanyon LE. Strain magnitude related changes in whole bone architecture in growing rats. *Bone* 1997; 20:191-8.
 66. Skerry TM. The regulation of gene expression in bone by mechanical loading. In: Russel RG, Skerry TM and Kollenkirchen U (ed) *Novel Approaches to Treatment of Osteoporosis*. New York, 1998:179-98.
 67. Hsieh YF, Burr DB, Turner CH. Strain adaptive modeling of the ulna in adult female rats. *Trans Orthop Res Soc* 2000; 25:143.
 68. Hsieh YF, Turner CH. Effects of frequency on mechanically-induced bone formation. *J Bone Miner Res*, 2001; in press.
 69. Rubin CT, Lanyon LE. Osteoregulatory nature of mechanical stimuli: function as a determinant for adaptive remodeling in bone. *J Orthop Res* 1987; 5:300-10.
 70. Ohashi N, Robling AG, Burr DB, Turner CH. Mechanical loading diminishes longitudinal growth rate and changes chondrocyte populations in the growth plate. *J Bone Miner Res* 2000; 15 (Suppl 1):S477.
 71. Robling AG, Duijvelaar KM, Geevers JV, Ohashi N, Turner CH. Modulation of appositional and longitudinal bone growth in the rat ulna by applied static and dynamic force. *Bone*; in press.
 72. Lanyon LE. Osteocytes, strain detection, bone modeling and remodeling. *Calcif Tissue Int* 1993; 53:S102-6.
 73. Brand RA, Stanford CM. How connective tissues temporally process mechanical stimuli. *Med Hypotheses* 1994; 42:99-104.
 74. Lanyon LE, Rubin CT. Static vs dynamic loads as an influence on bone remodeling. *J Biomech* 1984; 17:897-905.
 75. Turner CH, Owan I, Takano Y. Mechanotransduction in bone: role of strain rate. *Am J Physiol* 1995; 269:E438-42.
 76. Turner CH, Forwood MR, Otter MW. Mechanotransduction in bone: do bone cells act as sensors of fluid flow? *Faseb J* 1994; 8:875-8.
 77. Rubin CT, McLeod KJ. Promotion of bony ingrowth by frequency-specific, low-amplitude mechanical strain. *Clin Orthop* 1994; 298:165-74.
 78. Frost HM. Bone "mass" and the "mechanostat": a proposal. *Anat Rec* 1987; 219:1-9.
 79. Mosley JR, Lanyon LE. Strain rate as a controlling influence on adaptive modeling in response to dynamic loading of the ulna in growing male rats. *Bone* 1998; 23:313-8.
 80. Taaffe DR, Robinson TL, Snow CM, Marcus R. High-impact exercise promotes bone gain in well-trained female athletes. *J Bone Miner Res* 1997; 12:255-60.
 81. Basse EJ, Ramsdale SJ. Increase in femoral bone density in young women following high-impact exercise. *Osteoporos Int* 1994; 4:72-5.
 82. Rubin CT, Lanyon LE. Regulation of bone mass by mechanical strain magnitude. *Calcif Tissue Int* 1985; 37:411-7.
 83. Chow JW, Jagger CJ, Chambers TJ. Characterization of osteogenic response to mechanical stimulation in cancellous bone of rat caudal vertebrae. *Am J Physiol* 1993; 265:E340-7.
 84. Turner CH. Three rules for bone adaptation to mechanical stimuli. *Bone* 1998; 23:399-407.
 85. Turner CH, Takano Y, Owan I. Aging changes mechanical loading thresholds for bone formation in rats. *J Bone Miner Res* 1995; 10:1544-9.
 86. Rubin CT, Bain SD, McLeod KJ. Suppression of the osteogenic response in the aging skeleton. *Calcif Tissue Int* 1992; 50:306-13.
 87. Robling AG, Burr DB, Turner CH. Recovery periods restore mechanosensitivity to dynamically loaded bone. *J exp Biol*; submitted.
 88. Robling AG, Burr DB, Turner CH. Partitioning a daily mechanical stimulus into discrete loading bouts improves the osteogenic response to loading. *J Bone Miner Res* 2000; 15:1596-602.
 89. Pead MJ, Lanyon LE. Indomethacin modulation of load-related stimulation of new bone formation *in vivo*. *Calcif Tissue Int* 1989; 45:34-40.
 90. Forwood MR. Inducible cyclo-oxygenase (COX-2) mediates the induction of bone formation by mechanical loading *in vivo*. *J Bone Miner Res* 1996; 11:1688-93.
 91. Forwood MR, Kelly WL, Worth NF. Localisation of prostaglandin endoperoxide H synthase (PGHS)-1 and PGHS-2 in bone following mechanical loading *in vivo*. *Anat Rec* 1998; 252:580-6.
 92. Chow JW, Chambers TJ. Indomethacin has distinct early and late actions on bone formation induced by mechanical stimulation. *Am J Physiol* 1994; 267:E287-92.
 93. Gong G, Cullen DM, Peyton AC, Akhter MP, Recker RR. EP1 antagonist inhibition of bone formation induced by mechanical loading. *J Bone Miner Res* 2000; 15 (suppl 1):S477.
 94. Cullen DM, Personal communication; September 2000.
 95. Pitsillides AA, Rawlinson SC, Suswillo RF, Bourrin S, Zaman G, Lanyon LE. Mechanical strain-induced NO production by bone cells: a possible role in adaptive bone (re)modeling? *FASEB J* 1995; 9:1614-22.
 96. Fox SW, Chambers TJ, Chow JW. Nitric oxide is an early mediator of the increase in bone formation by mechanical stimulation. *Am J Physiol* 1996; 270:E955-60.
 97. Turner CH, Takano Y, Owan I, Murrell GA. Nitric oxide inhibitor L-NAME suppresses mechanically induced bone formation in rats. *Am J Physiol* 1996; 270:E634-9.
 98. Beamer WG, Donahue LR, Rosen CJ, Baylink DJ.

- Genetic variability in adult bone density among inbred strains of mice. *Bone* 1996; 18:397-403.
99. Noel LS, Champion BR, Holley CL, Simmons CJ, Morris DC, Payne JA, Lean JM, Chambers TJ, Zaman G, Lanyon LE, Suva LJ, Miller LR. RoBo-1, a novel member of the urokinase plasminogen activator receptor/CD59/Ly-6/snake toxin family selectively expressed in rat bone and growth plate cartilage. *J Biol Chem* 1998; 273:3878-83.
 100. Mason DJ, Suva LJ, Genever PG, Patton AJ, Steuckle S, Hillam RA, Skerry TM. Mechanically regulated expression of a neural glutamate transporter in bone: a role for excitatory amino acids as osteotropic agents? *Bone* 1997; 20:199-205.
 101. Skerry TM. Identification of novel signaling pathways during functional adaptation of the skeleton to mechanical loading: the role of glutamate as a paracrine signaling agent in the skeleton. *J Bone Miner Metab* 1999; 17:66-70.
 102. Raab-Cullen DM, Thiede MA, Petersen DN, Kimmel DB, Recker RR. Mechanical loading stimulates rapid changes in periosteal gene expression. *Calcif Tissue Int* 1994; 55:473-8.
 103. Mason DJ, Hillam RA, Skerry TM. Constitutive *in vivo* mRNA expression by osteocytes of beta-actin, osteocalcin, connexin-43, IGF-I, c-fos and c-jun, but not TNF-alpha nor tartrate-resistant acid phosphatase. *J Bone Miner Res* 1996; 11:350-7.
 104. Turner CH, Tu Y, Onyia JE. Mechanical loading of bone *in vivo* causes bone formation through early induction of c-fos but not c-jun or c-myc. *Ann Biomed Eng* 1996; 24 (suppl 1):S-74.
 105. Inaoka T, Lean JM, Bessho T, Chow JW, Mackay A, Kokubo T, Chambers TJ. Sequential analysis of gene expression after an osteogenic stimulus: c-fos expression is induced in osteocytes. *Biochem Biophys Res Commun* 1995; 217:264-70.
 106. Moalli MR, Caldwell NJ, Patil PV, Goldstein SA. An *in vivo* model for investigations of mechanical signal transduction in trabecular bone. *J Bone Miner Res* 2000; 15:1346-53.
 107. Lean JM, Jagger CJ, Chambers TJ, Chow JW. Increased insulin-like growth factor I mRNA expression in rat osteocytes in response to mechanical stimulation. *Am J Physiol* 1995; 268:E318-27.
 108. Westerlind KC, Turner RT. The skeletal effects of spaceflight in growing rats: tissue-specific alterations in mRNA levels for TGF-beta. *J Bone Miner Res* 1995; 10:843-8.
 109. Rawlinson SC, Zaman G, Mosley JR, Pitsillides AA, Lanyon LE. Heme oxygenase isozymes in bone: induction of HO-1 mRNA following physiological levels of mechanical loading *in vivo*. *Bone* 1998; 23:433-6.
 110. Webb CM, Zaman G, Mosley JR, Tucker RP, Lanyon LE, Mackie EJ. Expression of tenascin-C in bones responding to mechanical load. *J Bone Miner Res* 1997; 12:52-8.
 111. Chow JW, Wilson AJ, Chambers TJ, Fox SW. Mechanical loading stimulates bone formation by reactivation of bone lining cells in 13-week-old rats. *J Bone Miner Res* 1998; 13:1760-7.
 112. Turner CH, Owan I, Alvey T, Hulman J, Hock JM. Recruitment and proliferative responses of osteoblasts after mechanical loading *in vivo* determined using sustained-release bromodeoxyuridine. *Bone* 1998; 22:463-9.
 113. Boppard MD, Kimmel DB, Yee JA, Cullen DM. Time course of osteoblast appearance after *in vivo* mechanical loading. *Bone* 1998; 23:409-15.