

THE EFFECT OF FULL-CONTOUR Y-TZP CERAMIC SURFACE ROUGHNESS ON
THE WEAR OF BOVINE ENAMEL AND SYNTHETIC HYDROXYAPATITE:
AN IN-VITRO STUDY

by

Alaa Hussein Aref Sabrah

Submitted to the Graduate Faculty of the School of
Dentistry in partial fulfillment of the requirements
for the degree of Master of Science in Dentistry,
Indiana University School of Dentistry, December 2011.

Thesis accepted by the faculty of the Department of Restorative Dentistry, Indiana University School of Dentistry, in partial fulfillment of the requirements for the degree of Master of Science in Dentistry.

Melvin Lund

Michael A. Cochran

Anderson Hara

Marco Bottino
Chairman of the Research
Committee

N. Blaine Cook
Program Director

Date

DEDICATION

All praise is for God, who helped me to accomplish this thesis. May He help me to remember, to praise, and to worship Him. This thesis is dedicated to my parents, a great source of motivation, inspiration, and support, and to my brother and my sisters, who were always by my side. May God bless them all.

ACKNOWLEDGMENTS

I would like to convey my deepest gratitude to Jordan University for giving me the opportunity to continue my graduate studies.

I would like to express the deepest appreciation to my supervisors, Dr. Marco C. Bottino, and Dr Anderson Hara. Without their guidance, this thesis would not have been possible. I am also grateful to my committee members for all their help. A special thank-you goes to Dr. N. Blaine Cook for his unlimited support. I offer my regards, also, to all who supported me during the completion of my project and thesis.

I am heartily thankful for my family and friends, and for all they have done for me.

A special note of thanks goes to Ivoclar-Vivadent Company for supplying the materials used as well as the ability to work at their laboratories. My deepest gratitude goes to Dr. Dana Qeblawi, Dr. Thomas Hill, and Omar Nihlawi.

I would like to thank Dr. Platt for all his support, and Meaghan MacPherson for all her assistance in the laboratory.

Lastly, this research was partially funded by Delta Dental Foundation.

TABLE OF CONTENTS

Introduction.....	1
Review of Literature.....	6
Methods and Materials.....	15
Results.....	24
Tables and Figures.....	29
Discussion.....	76
Summary and Conclusion.....	84
References.....	86
Abstract.....	90
Curriculum Vitae	

LIST OF ILLUSTRATIONS

TABLE I	Descriptive statistics for zirconia surface roughness.....	30
TABLE II	Descriptive statistics for zirconia height loss.....	31
TABLE III	Descriptive statistics for antagonist height loss.....	31
TABLE IV	Descriptive statistics for antagonist volume loss.....	32
TABLE V	One-way ANOVA comparing different groups.....	33
FIGURE 1	FCZ zirconia disk as provided by the manufacturer to be cut into blocks for further milling with the CAD/CAM milling unit.....	34
FIGURE 2	Zirconia blocks preparation steps for CAD/CAM milling.....	35
FIGURE 3	CAD/CAM milling facility at Ivoclar-Vivadent labs, Buffalo, NY.....	36
FIGURE 4	Zirconia sliders fabrication using CAD/CAM machine.....	37
FIGURE 5	Sintering.....	38
FIGURE 6	Zirconia mounting jig fabrication and mounting steps.....	39
FIGURE 7	A) Schematic representation of zirconia slider showing the shape and dimensions of the slider. B) A mounted slider specimen with the slider tip extending above the mounting acrylic.....	40
FIGURE 8	Schematic representation of the experimental groups tested.....	41
FIGURE 9	Glaze application to the zirconia sliders (Group 2).....	42
FIGURE 10	Original scan of Zirconia surface taken by Proscan 2000 profilometer using S5/03sensor, with a step size of 0.01 for both x and y axis, frequency (Hz)= 100, and scanned area of 0.8 × 0.8 mm.....	43
FIGURE 11	A) Zirconia surface scan after processing by the Proscan software; outlier points have been removed, and color scale has been changed to gray. B) Generated roughness measurements.....	44

FIGURE 12	A) Sputter-coater (Denton Vacuum Desk II) and B) zirconia samples sputter coated with gold prior to SEM imaging.....	45
FIGURE 13	Low-vacuum scanning electron microscope (LV SEM).....	46
FIGURE 14	Baseline vertical height measurements for zirconia samples taken by digital micrometer.....	47
FIGURE 15	Bovine teeth preparation and mounting steps.....	48
FIGURE 16	Hydroxyapatite mounting steps.....	49
FIGURE 17	Polishing HA and bovine samples.....	50
FIGURE 18	A) HA surface scan provided by the Proscan. B) Generated roughness measurements.....	51
FIGURE 19	A) Bovine enamel surface scan provided by the Proscan. B) Generated roughness measurements.....	52
FIGURE 20	Hardness test and parameters.....	53
FIGURE 21	Two-body pin-on-disk machine, and wear testing parameters.....	54
FIGURE 22	Zirconia vertical height loss measurements.....	55
FIGURE 23	Non-contact profilometer - Proscan 2000 (Scantron, Taunton, England).....	56
FIGURE 24	Wear track formed on HA (left) and bovine (right).....	57
FIGURE 25	Vertical height loss measurements.....	58
FIGURE 26	Example of vertical height loss.....	59
FIGURE 27	Volume loss measurement by Proscan software; using the same after-wear scan for each sample; volume loss was measured by the software.....	60
FIGURE 28	Zirconia surface roughness values (Ra and Rq in μm) before wear testing for the different groups along with standard deviation.....	61
FIGURE 29	SEM micrographs at different magnifications (A) X50; (B) X500 and (C) X1500 for group 1 (as-machined zirconia sliders).....	62

FIGURE 30	SEM micrographs at different magnifications (A) X50; (B) X500 and (C) X1500 for group 2 (glazed zirconia sliders).....	63
FIGURE 31	SEM micrographs at different magnifications (A) X50; (B) X500 and (C) X1500 for group 3 (bur-finished zirconia sliders).....	64
FIGURE 32	SEM micrographs at different magnifications (A) X50 (B) X500 and (C) X1500 for group 4 (bur-finished and polished zirconia sliders).....	65
FIGURE 33	Zirconia slider height loss opposing HA antagonist.....	66
FIGURE 34	Zirconia slider height loss when opposing different antagonists...	67
FIGURE 35	HA height loss against different zirconia groups.....	68
FIGURE 36	HA height loss against different zirconia groups.....	69
FIGURE 37	Different antagonists (HA, bovine) height loss against glazed/polished zirconia groups.....	70
FIGURE 38	Different antagonists (HA, bovine) height loss against glazed/polished zirconia groups.....	71
FIGURE 39	SEM micrographs at different magnifications (A) X75; (B) X500 and (C) X1500 of the HA surface against group 1 (as-machined zirconia sliders).....	72
FIGURE 40	SEM micrographs at different magnifications (A) X75; (B)X500 and (C)X1500 of the HA surface against group 2 (glazed zirconia sliders).....	73
FIGURE 41	SEM micrographs at different magnifications (A) X75; (B) X500 and (C)X1500 of the HA surface against group 3 (bur-finished zirconia sliders).....	74
FIGURE 42	SEM micrographs at different magnifications (A) X75; (B) X500 and (C) X1500 of the HA surface against group 4 (bur-finished and polished zirconia sliders).....	75

INTRODUCTION

The esthetic and biocompatible properties of dental ceramics have stimulated extensive researches to improve their inferior mechanical properties compared with metallic restorations.¹ Recent improvement of the mechanical properties of structural zirconia ceramics has enlarged its application in dentistry.² While the first biomedical application of zirconia occurred in 1969, its use in dentistry started in the early 1990s, and since then zirconia ceramics have been used in the fabrication of endodontic posts, dental implants, implant abutments, orthodontic brackets, crown cores, and fixed partial denture prosthesis (FPDP) frameworks.³

Zirconia is a polymorphic material present in three forms. At its melting point of 2680°C, it has a cubic structure that transforms into tetragonal structure below 2370°C. Then, the tetragonal transforms to a monoclinic structure below 1170°C. The later transformation results in a 3-percent to 5-percent volume expansion, which causes high internal stresses. In order to control the volume expansion and stabilize zirconia in the tetragonal phase at room temperature, Yttrium-oxide (Y_2O_3 , 3-percent-mol) is usually added to pure zirconia. This partially stabilized zirconia has high flexural strength and fracture toughness.² A special phenomenon associated with partially stabilized zirconia is known as “transformation toughening.” It occurs when an increase in the tensile stresses at a crack tip causes the transformation from the tetragonal phase to the monoclinic phase resulting in almost 3-percent to 5-percent localized expansion. Localized expansion triggers compressive stresses at the crack tip, counteracting the external tensile stresses and hence retarding crack propagation. However, the toughening mechanism does not

prevent the progression of a crack; it just makes it harder for the crack to propagate. Thus, in the presence of higher stresses, crack propagation is expected. Yttrium-oxide stabilized tetragonal zirconia polycrystal (Y-TZP) has mechanical properties that are desirable for restorative dentistry: chemical and dimensional stability, high mechanical strength, and fracture toughness.³

Despite the good mechanical properties of zirconia ceramics, current processing technologies cannot make zirconia frameworks look as translucent as natural teeth, nor can they provide shade characterization. Therefore, zirconia cores or frameworks are generally veneered with porcelain to achieve a more natural appearance.¹ Veneering tough zirconia ceramic cores with traditional porcelains led to the fabrication of esthetic, all-ceramic restorations that are strong enough to replace metal-supported porcelain restorations. In specific clinical situations, for example, when the occlusal or palatal space is limited or in cases where a patient's parafunctional activity (e.g. bruxism) may contraindicate the use of porcelain occlusals, the use of unveneered zirconia ceramic seems to be an option for all ceramic restorations.⁴ Zirconia has high strength and is tooth-colored; as a result, dental laboratories have started to promote glazed all-zirconia crowns without veneering porcelain.

The wear of human enamel and opposing restorative materials are of great concern when selecting restorative materials for clinical treatment. Wear and loss of enamel are irreversible and can lead to the need for complex restorative procedures. Indeed, the loss of enamel could cause occlusal instability as well as potential dentin exposure.⁵

A smooth restoration surface is important to avoid dental complications such as plaque formation, gingivitis, periodontitis, and wear of the opposing dentition. It is also important for patient comfort.⁴ Surface smoothness and roughness play a major role in restorative material wear behavior.⁴ Wear usually occurs at the tips of the highest asperities, and given that increasing surface roughness is associated with increased asperities, a rougher surface is expected to cause more wear than a smoother one.⁶

As a general rule, ceramic materials cause greater abrasive wear of human enamel compared with other restorative materials,^{5,7} but very little information is available concerning the effect of surface roughness of unveneered zirconia against the natural dentition. Usually, occlusal adjustments of the restorations are necessary after cementation. The use of diamond burs may remove the glazing material and impact the ceramic surface roughness. Therefore, the re-establishment of a smooth, glazed-like zirconia surface using intraoral polishing instruments or kits is of great clinical importance, because it may help to minimize the effects of surface roughness on antagonist wear.^{5,7}

Human enamel is considered to be the best material for *in-vitro* wear testing evaluation. A disadvantage of using unmodified enamel cusps is that the shape of the cusps varies among specimens as well as its natural substrate.^{5,8} An important alternative to human enamel substrate variability has been the use of synthetic hydroxyapatite.⁹⁻¹⁰

The objectives of this study were: 1) To investigate the effects of different surface treatments on the surface roughness of a yttrium-stabilized tetragonal zirconia polycrystal ceramic (Y-TZP, Ardent Dental, Inc.); 2) To evaluate the influence of zirconia surface

roughness on the wear behavior against bovine enamel and synthetic hydroxyapatite; 3) To compare wear behavior between bovine enamel and synthetic hydroxyapatite.

HYPOTHESES

The null hypotheses of this study were: 1) The different polishing techniques tested would result in similar zirconia surface roughness values; 2) Zirconia surface roughness would not affect the wear of bovine enamel and hydroxyapatite specimens; 3) Bovine enamel and hydroxyapatite specimens would present similar wear characteristics.

The alternative hypotheses were: 1) The different polishing techniques would result in distinct zirconia surface roughness values; 2) Zirconia surface roughness would affect the wear of both bovine enamel and hydroxyapatite; 3) Bovine enamel and hydroxyapatite specimens would have different wear characteristics.

REVIEW OF LITERATURE

WEAR

Wear is defined as the removal of material from a solid surface as a result of mechanical interaction between two relatively moving surfaces.¹¹

Dental wear refers to the wear process involving dentition and it is often called “tooth wear.” Tooth wear is a complex process and can be affected by many factors that includes; the abrasive nature of food, parafunctional habits, neuromuscular force, enamel thickness, enamel hardness (affected by degree of mineralization), dental structural direction, and enamel prisms orientation, presence of opposing restorative materials with different wear behavior compared with tooth structure, as well as pH and nature, viscosity, and flow rate of the saliva.¹²

There are many types of tooth wear. The most common types mentioned in the literature are attrition, abrasion, and erosion. Attrition is defined as the physiological wearing of dental hard tissue due to tooth-to-tooth contact with no foreign substance intervening.¹³ Abrasion, on the other hand, is the pathological wearing of dental hard tissue through abnormal mechanical processes involving foreign objects or substances repeatedly introduced in the mouth and contacting the teeth.¹³ Erosion differs from the previous two types in that dental hard tissues are chemically etched from the tooth surface by acid and chelating agents.¹⁴ During function and with the presence of diet and saliva, a combination of the three types might be observed.¹³

Abrasive wear is the primary form of wear occurring in dentistry¹² and is further subdivided into two types: two-body and three-body abrasion. In two-body wear the

surfaces are worn by direct contact between opposing surfaces. This usually occurs during non-masticatory tooth movement and are especially prevalent with parafunctional habits (i.e. bruxism).¹⁵ In the three-body wear, the surfaces are worn away by the slurry of abrasive particles that intervene between the moving surfaces. This occurs usually during mastication, so that it is mostly prevalent in patients eating an abrasive diet.¹⁵ The purpose of two-body wear testing is to simulate attrition created by direct occlusal contact of teeth or restorative materials during grinding and bruxism. The purpose of three-body wear testing is to simulate the masticatory process when food exists between opposing teeth. A combination of two-body and three-body wear usually occurs between opposing enamel and any restorative materials in the oral cavity. The wear rates of restorative materials are greater from two-body wear than from three-body wear.¹⁶

Dental wear is a physiological process found in every population of all ages. The loss of enamel and the underlying softer dentin is a continuous phenomenon during the life cycle of each tooth.¹⁷ However, a modern diet and the higher prevalence of tooth decay increased the use of restorative materials to repair or even replace dental hard tissues, which might affect and accelerate the physiological wear rates.

To prevent accelerated enamel loss by wear and its complications, an ideal restorative material should behave like natural enamel when placed in the oral cavity. According to Lambrechts et al.,¹⁷ the normal physiological wear of human enamel is estimated to be around 38 μm per year for molars during the running-in period (first year after restoration placement), and 29 μm per year for the steady-state period (begins two years after restoration placement). For the premolars, it was 18 μm per year during the running-in period, and 15 μm per year during the steady-state period. Slightly higher

wear rates are observed during the running-in period compared with the steady state. When no other restorative treatments are performed, a dynamic balance in the occlusion will be established.¹⁷ It is worth mention that in this *in-vivo* study, all restorative treatments for each patient were done from the beginning to establish a balanced occlusion.

As wear measurements *in vivo* are complicated and time-consuming,¹⁸ many *in-vitro* wear simulation devices and methods have been introduced. The advantages of *in-vitro* models include: the examination of larger numbers of samples over relatively short periods of time; a controlled exposure time; the achievement of a high level of standardization; the ability to control numerous variables, and usefulness for demonstrating the wear behavior of a substance.¹⁵ On the other hand, it cannot replicate the oral environment precisely with all its biological variations. In fact, *in-vitro* models give us information only about trends and indications about the true extent of wear.¹⁵

Many factors contribute to tooth wear in the oral cavity. The factors identified in studies affecting *in-vitro* wear include surface quality, resistance to fatigue and fracture, surface roughness of the antagonist, magnitude of loading, sliding distance and speed, coefficient of friction, and the properties and structure of materials.^{1,4,19} An interesting finding by Seghi et al.²⁰ is that Knoop hardness shows poor correlation with the results of abrasive wear testing.

The complexity of studying and comparing wear measurements literature is greatly related to the wide variety of wear machines used, the types of antagonists, the composition and the shape of sliders (stylus), the number of cycles, the geometry of tested materials, the load used, the frequency of cycles, and the type of movements.

CERAMIC RESTORATIONS AND ZIRCONIA CERAMIC AS ANTAGONIST MATERIALS TO HUMAN TEETH

Many researchers have studied the wear behavior of different ceramic materials against human enamel. As a general rule, ceramic materials cause greater abrasive wear of human enamel compared with other restorative materials.^{5,7} As mentioned previously, zirconia cores and frameworks are usually veneered with porcelain to make more esthetically pleasing restorations.¹ This might be a reason for having so few studies on the wear behavior of zirconia ceramic itself, because most research to date focuses on veneering ceramics and bonding to the underlying zirconia core.

When occlusal or palatal space is limited, the use of un-veneered zirconia ceramic might be an option for all ceramic restorations. Therefore, the wear behavior of zirconia ceramic as an antagonistic material would be important clinically. Recent advancements in zirconia stain and glaze techniques and the commercial promotion of all-zirconia crowns prompted more studies of the wear and abrasive characteristics of zirconia.^{1,4,19,21-}

22

Preis et al.²² compared the wear of flat zirconia (five different zirconia ceramics) and four different veneering porcelain materials with different surface finishes (glazing/polishing) against human enamel and steatite sliders (made of magnesium silicate). The results showed no measurable wear on zirconia surfaces compared to 90- μm to 233- μm wear tract on the veneering porcelain. The authors did not measure the wear of enamel against zirconia due to technical problems involving human enamel wear quantification, but they reported a measured wear area of 0.8 mm^2 to 1.4 mm^2 of steatite

sliders against zirconia. An interesting finding is that antagonistic wear (steatite) against zirconia was lower than wear against porcelain.

In another study by Albashaireh et al.,¹ an explanation of the low wear of zirconia ceramic compared with other types of ceramic has been given. The authors suggested that differences in flexural strength and toughness are related to the amount of wear observed. They stated that zirconia had the highest flexural strength (900 MPa) and fracture toughness ($5.5 \text{ MPa m}^{1/2}$) among the studied materials and exhibit the least substance loss.¹ In other words, flexural strength and fracture toughness have an indirect correlation to wear loss of a ceramic material.

Ghazal et al.⁴ evaluated and correlated the wear of human enamel and nano-filled composite against zirconia balls with different surface roughness average values. The rationale for their study was that finishing techniques of ceramic lead to different surface roughness values. Briefly, three different surface roughness for zirconia were used ($R_a = 0.24 \text{ }\mu\text{m}$, $0.75 \text{ }\mu\text{m}$, and $2.75 \text{ }\mu\text{m}$). The results showed a measured human enamel vertical height loss ranging from $25 \text{ }\mu\text{m}$ to $131 \text{ }\mu\text{m}$, and volume loss ranging from 0.012 mm^3 - 0.211 mm^3 . The increase in the antagonist surface roughness (zirconia) significantly increases both the wear of human enamel and composite resin.

Ghazal et al.¹⁹ investigated the effect of load magnitude on the wear of human enamel and composite resin against zirconia balls. The results revealed a vertical height loss of tooth enamel ranging from $19 \text{ }\mu\text{m}$ to $35 \text{ }\mu\text{m}$ under 49 N load. The increase in the loading force significantly increased the wear of human enamel up to $46 \text{ }\mu\text{m}$ under 75 N load. These results highlight the significance of masticatory forces as an important factor affecting wear.

In most wear literature a load of 49N is used because it represents the average physiological biting forces for a normal person (i.e., non-bruxing person).⁷

EFFECT OF SURFACE TREATMENT ON WEAR BEHAVIOR (GLAZING VERSUS POLISHING)

Surface polishing has been reported to equal or exceed the smoothness achieved with surface glazing.^{12,23} Selective grinding to adjust the occlusion of a restoration will remove the glazing material. In such cases polishing a restoration is considered critical to re-establish a smooth surface. Therefore, it is important to evaluate the wear characteristics of a polished surface compared with a glazed one.¹

While many studies have compared different surface treatments on surface roughness of ceramic, especially between glazed and polished surfaces, few studies are available on the effects of different surface treatments on the surface roughness of zirconia ceramic and the associated antagonist wear behavior.

Rosentritt et al.²⁴ studied the two-body wear of different ceramics (glazed and unglazed) against steatite balls and human enamel. Three types of Y-TZP ceramics were used, from which one system (Prettau) is available on the market for the fabrication of full-zirconia fixed dental prostheses without veneering. Ra values for the three zirconia systems were about 0.1 μm and were not significantly different from other glazed ceramics. An interesting finding from this study was that sliding of the steatite antagonist on hard zirconia surface caused only flattening of the antagonist surface, which led the authors to conclude zirconia can be used safely for the fabrication of fixed dental prostheses without veneering.

The surface roughness parameter used almost always in literature is Ra.^{1,4,22,24} Ra is a mathematical average value of the profile departure from the mean line within a sampling length. For statistical work, another parameter (Rq) is considered more meaningful than Ra. Rq is the square root of the average of the square of the deviation of the profile departure from the mean line. This parameter has the ability to detect atypical peaks and valleys. In our study, we have included both measurements.

MATERIALS USED AS SUBSTITUTES FOR HUMAN ENAMEL

The best choice for the *in-vitro* study of wear is human enamel. However, there are some complications and disadvantages to using natural human enamel, including the inability to obtain enamel samples of the proper size to fit the wear machines and wide variations in shape and physical properties between specimens. Also, enamel samples require extensive preparation (sectioning individual cusps, cutting standard size sliders, then finishing and polishing) and standardization is almost impossible due to natural substrate variations. All this may lead to a variation in results.¹¹

Therefore, a substitute material that has similar average properties to that of human enamel would greatly improve the results obtained from simulation of wear testing.¹¹ Stainless steel, steatite, synthetic hydroxyapatite, dental porcelain, and zirconia ceramic balls have been used as stylus substrates to evaluate wear in research studies.^{1,4,9-11,19,21}

It is unexpected to find a material having the same properties as human enamel in all aspects. However, trying to select a material that simulates natural human dental enamel as closely as possible in terms of structural, mechanical and chemical properties is most essential in wear study design.¹¹

Synthetic hydroxyapatite has been used as a substitute for enamel in previous studies.⁹⁻¹⁰ Given that human enamel consists of more than 85-percent hydroxyapatite might be a valid justification for using synthetic hydroxyapatite.

The use of bovine enamel as a substitute to human enamel is very common, especially in erosion abrasion studies. Recent wear studies suggest that bovine enamel shows less resistance to wear and abrasion compared with human enamel.²⁵⁻²⁶

Mehl et al.²⁶ compared the wear of six composite resins to that of human and bovine enamel in a dual-axis masticatory machine. They reported that wear values for bovine enamel were almost three times higher than those for human enamel. Although this difference was not statistically significant, their conclusion stated that bovine enamel is not a suitable substitute for human enamel in *in-vitro* wear test.

Throughout the wear literature, antagonist materials and slider materials have varied considerably, and almost all materials have been used as both antagonists and sliders. Albashaireh et al.¹ stated that while the use of human enamel is considered the best choice for a slider material, the lack of standardization and the variability in shape and wear behavior remains a problem. The use of a material that maintains its shape throughout the wear test (e.g., zirconia balls) is an advantage to minimize the effect of slider shape on wear behavior of the antagonist materials.

MATERIALS AND METHODS

The experimental study design consisted of two parts: Part One was aimed at investigating the effect of different surface treatments on full-contour zirconia surface roughness. The two-body wear behavior of those zirconia groups was studied against synthetic HA. Part Two was aimed at comparing the wear behavior of two different antagonist materials, bovine enamel and HA, against glazed and polished full-contour zirconia ceramics.

PREPARATION OF ZIRCONIA SPECIMENS (Y-TZP)

Forty-eight yttrium-stabilized full-contour zirconia (FCZ, Ardent Dental Inc., NY) ceramic specimens (hereafter named zirconia sliders) were manufactured using a CAD/CAM machine (Sirona, InLab MC XL). The zirconia material came from the manufacturer as a large disk-shaped block (Figure 1). Small cubic zirconia blocks (10 x 10 x 10 mm³) were prepared using a band saw. Next, the samples were placed in a furnace (Pyro oven, HD Justi Company, CA) at 275° F for 30 minutes to remove the moisture. Using a custom jig, each block was glued to a CAD/CAM fitting pin (Figure 2) in preparation for milling. To facilitate the CAD/CAM process a slider replica of the proper shape and size was machined from an aluminum rod and scanned by a digital scanner (Sirona, InLab MC XL) (Figure 3 and Figure 4). This information was sent to the CAD/CAM milling machine. The zirconia samples were then milled to the required shape and dimensions (Figure 4). The base of each sample measured 6 mm in diameter and 4 mm high. The slider portion of each sample was 2 mm in diameter and 1.5 mm high.

Subsequently, the specimens were sintered in a high-temperature furnace (Programat S1, Ivoclar-Vivadent, Buffalo, NY) at 1500°C for 8 hours. The specimens experienced 19.264-percent shrinkage during sintering. The computer software compensates for this shrinkage during milling to produce finished specimens of the proper size (Figure 5).

A custom silicone mold was fabricated to be used as a mounting jig for the zirconia slider samples to brass holders that will attach to the wear machine (Figure 6). A cylindrical plastic sleeve was attached to a brass holder with wax. Then, the sleeve was filled with molten wax. The slider end of the previously described metal slider replica was inserted into the end of a dental surveyor rod. With the brass holder assembly resting on the surveyor base, the metal slider replica was lowered into the soft wax until the top of the replica base was even with the top of the plastic sleeve. The 1.5-mm slider was left exposed (Figure 6, item B). The dental surveyor was used to ensure that the specimens were mounted so that the slider end was parallel to the surface of the antagonist specimen during testing. Excess wax was removed and the wax was allowed to cool. Next, the mounted metal slider replica was inserted into vinyl polysiloxane impression material (Exafast, GC America, Inc.) and the impression material was allowed to set. Then, the mounted replica assembly was removed from the impression to leave a silicone mounting jig (Figure 6, item C).

To mount the zirconia slider specimens, each specimen was inserted slider end first into the silicone mold (Figure 6, item D). Then, auto-polymerizing acrylic resin (Bosworth Fastray, Harry J. Bosworth Co, IL) was mixed and poured into the mold over the base of the zirconia slider. A lubricated brass holder was then placed into position

inside the mold, and slight finger pressure was used to hold it in place until the acrylic polymerized (Figure 6, item D). Figure 7 shows the mounted zirconia specimen with the 1.5 mm slider exposed for testing.

The zirconia sliders were randomly allocated to four groups (n= 8) according to the surface finishing/polishing procedure as follows: G1-as-machined; G2-glazed; G3-diamond bur-finishing for 10 s using a high-speed hand piece under water cooling (Fine needle diamond bur, #8392.31.016, Brasseler, USA); and G4-diamond bur-finishing (Fine needle diamond bur, #8392.31.016, Brasseler) followed by polishing with OptraFine polishing kit (Ivoclar-Vivadent, NY). Each polishing step was carried out for 30 s, followed by polishing using the diamond paste supplied with the polishing kit for one minute. All specimens were immersed in distilled water and cleaned for three minutes in an ultrasonic bath after surface treatment.

The four groups were to be tested against synthetic hydroxyapatite (HA) antagonists. Two additional groups (n = 8) representing G2-glazed, and G4-diamond bur-finishing (Fine needle diamond bur, #8392.31.016, Brasseler) followed by polishing with OptraFine polishing kit (Ivoclar-Vivadent, NY) were prepared in the same fashion to be tested against bovine enamel antagonists. A summary of the test groups is presented in Figure 8.

The G2-Glazed group specimens were glazed following manufacturer instructions using full-contour zirconia glaze (Diazir, Diadem Precision Technology, MI) before mounting in acrylic resin. The firing procedure was done according to the manufacturer instructions using a Programat P500 furnace (Ivoclar-Vivadent) (Figure 9).

Baseline average surface roughness parameters (R_a , in μm ,) and (R_q , in μm) were recorded using a non-contact 3D profilometer (Proscan 2000, Scantron, Taunton, England) and dedicated software (version 2,0,17 Scantron Industrial Products Ltd., Taunton, England) for each zirconia slider.²⁷⁻²⁸ The mean R_a and R_q values were associated with each zirconia experimental group. An example of surface roughness scanning and measurements is shown in Figure 10 and Figure 11.

One additional specimen per group was prepared and evaluated under a scanning electron microscope to obtain qualitative images of the Y-TZP surfaces after sample preparation (JEOL JSM-5310LV, Jeol Ltd, Tokyo, Japan). The specimens were sputter-coated with gold, then evaluated at X50, X500 and X1500 magnification at 20 kV acceleration voltages. The qualitative information aims to show the differences in surface topography in relation to roughness values obtained from the Proscan measurements.⁴ Sputter-coated specimens and SEM pictures are shown in Figures 12 and 13.

Baseline vertical height for each zirconia sample was measured by a digital micrometer (Digi-micro, Nikon) in millimeters. Four readings were taken for each sample from four different locations situated on two cross lines marked on the zirconia slider base (Figure 14).

PREPARATION OF ENAMEL AND HYDROXYAPATITE ANTAGONIST SPECIMENS

In this study, bovine enamel and synthetic hydroxyapatite (HA) were used as an alternative to human enamel. Sixteen freshly extracted and caries-free bovine incisor teeth were obtained from Oral Health Research Institute (IUSD) and stored in 0.1-percent thymol solution until preparation for testing. The teeth were sectioned horizontally to

remove the root and then wet-flattened with 180-grit SiC paper into a specimen with a flat square-shaped facial surface. The flat facial surface was used for wear testing. The flat enamel sections were mounted in brass holders using auto-polymerizing acrylic resin in much the same way that the zirconia sliders were mounted. The specimens were then stored in distilled water at room temperature until testing.⁵ According to our pilot studies, the minimum surface area of enamel required for the wear testing was 64 mm² (Figure 15).

Similarly, sintered (n=32) disk-shaped (13 mm in diameter × 2.9 mm in height) synthetic hydroxyapatite (Orthoblock, Calcitek Inc., Carlsbad, CA) samples were mounted in brass holders (Figure 16).

Subsequently, both bovine enamel and HA specimens were wet-finished with SiC paper (600 grit to 1200 grit) to obtain a flat and standardized test surface (Figure 17).¹⁰ Samples were cleaned in an ultrasonic bath in distilled water for three minutes, then stored in distilled water at room temperature until testing.

Baseline surface average roughness (Ra, in μm) was recorded using a non-contact profilometer (Proscan 2000, Scantron, Taunton, England) for each specimen. Parameters and an example of surface scan are shown in Figure 18 and Figure 19. Surface roughness measurements were done to confirm standardization among all samples.

Vickers hardness for HA was measured for five samples and the average recorded as the hardness for all HA samples. Vickers hardness for bovine enamel was also measured for each sample. Due to a wide sample area, the average of 15 points per sample was taken as the Vickers hardness for that sample. Samples with Vickers hardness

less than 270 were excluded. In cases of the presence of cracks or dentin exposure after polishing, the sample was also excluded. Hardness parameters are shown in Figure 20.

WEAR TESTING

To simulate the wear that occurs in the occlusal contact, a two-body pin-on-disk wear test was performed. A two-body rotating pin-on-disk wear testing machine (IUSD Biomaterials Lab, Indiana University, Indianapolis, IN) containing four wear stations was used. The brass holders containing the mounted test specimens have a large screw protruding out the end that is used for attaching the specimen to the wear machine. The mounted HA and bovine specimens were attached to the upper stationary member of the wear stations. The zirconia sliders were attached to the lower rotating component of the wear stations. The stations rotate at a constant speed with a radius of movement of approximately 3 mm to 4 mm.²⁹ The wear test was run for 25,000 cycles at 1.2 Hz. The wear stations were washed continuously with water for the entire testing period to prevent the effect of debris on the wear test (Figure 21). After the wear testing, specimens were removed and cleaned with distilled water in an ultrasonic bath for six minutes.

Zirconia sliders were evaluated for height loss using the digital micrometer. The differences in height before and after wear were recorded as zirconia vertical height loss (μm) (Figure 22).

The vertical substance loss, i.e., the maximum depth of the wear area (in μm) and the volume loss (mm^3) of each of the HA and bovine specimens were measured using a non-contact optical profilometer (Proscan 2000, Scantron, Taunton, England) (Figure 23) by comparing the wear track to unworn areas.³⁰ The shape of the wear track is shown in Figure 24. The measurements procedure for vertical height loss is given in Figure 25.

Figure 26 shows an example of vertical height loss measurements on the computer screen. Measurements of volume loss are shown in Figure 27.

Scanning electron microscopy was performed to provide additional qualitative data on the wear characteristics of hydroxyapatite specimens at different magnifications. One specimen representing each group was sputter coated with gold, and evaluated at X75, X500, and X1500 magnification.

STATISTICAL METHODS

Summary statistics (mean, standard deviation, standard error, range) were calculated for surface roughness for each of the four Y-TZP finishing/polishing techniques. Summary statistics were calculated for each of the four polishing technique/specimen (bovine enamel or synthetic hydroxyapatite) combinations for wear depth and volume for both the YSZ sliders and enamel/hydroxyapatite specimens. One-way analysis of variance (ANOVA) was used to determine the effect of the polishing techniques on surface roughness. Comparisons between groups for differences in antagonist height loss, antagonist volume, and slider height loss were performed using one-way ANOVA. Analyses were performed after a natural logarithm transformation of the data to satisfy the assumptions required for the ANOVAs. The statistical significance level was set at $\alpha = 0.05$ for all tests.

SAMPLE SIZE JUSTIFICATION

In two previous studies,^{1,4} the standard deviation for wear depth was reported to be 4 μm . With eight (8) samples per polishing technique/specimen (enamel/hydroxyapatite) combination, the study would have 80-percent power to detect a

wear-depth difference of 6.1 11m between any two groups, assuming two-sided tests each conducted at a 5-percent significance level.

RESULTS

Hardness values for both HA and bovine were recorded to ensure they are close to standard values of human enamel (320 VH to 360 VH).⁴ The average Vickers hardness for HA was 467.6 VH. For bovine enamel, the hardness ranged from 270 VH to 314 VH.

Mean and standard deviation for zirconia surface roughness following the four surface treatments were calculated and are presented in Table I. Mean and standard deviation for antagonist height loss and volume loss were calculated and are presented in Table II and Table III, respectively. Mean and standard deviation for zirconia height loss following wear test was also calculated (Table IV).

Comparisons between groups for differences in surface roughness, antagonist height loss, antagonist volume, and slider height loss were performed using one-way ANOVA. Analyses were performed after a natural logarithm transformation of the data, in order to satisfy the assumptions required for the ANOVAs.

THE EFFECT OF SURFACE TREATMENT ON ZIRCONIA SURFACE TOUGHNESS

According to the four surface treatments produced, surface roughness was significantly higher for the as-machined and bur-finished zirconia sliders (Ra: 0.84 μm /0.89 μm , and Rq: 1.13 μm /1.2 μm respectively) than for glazed and polished zirconia sliders ($p < 0.0001$) (Ra: 0.42 μm /0.49 μm , and Rq: 0.63 μm /0.76 μm , respectively).

Comparing glazed and polished zirconia sliders, it was found that surface roughness was significantly higher for polished zirconia sliders (Ra = 0.49, Rq = 0.76) than for glazed zirconia sliders (Ra = 0.42, Rq = 0.63) ($p = 0.0013$ for Ra, $p = 0.0001$ for

Rq). Surface roughness was not significantly different between as-machined ($R_a = 0.84$, $R_q = 1.13$) and bur-finished zirconia sliders ($R_a = 0.89$, $R_q = 1.20$) ($p = 0.43$). Results are shown in Table V and Figure 28.

SEM images at X50, X500, and X1500 magnification showed differences in surface topography comparable to the roughness values obtained from the Proscan measurements. G2-glazed group ($R_a = 0.42$, $R_q = 0.63$) had the smoothest surface under SEM, while G1-as machined ($R_a = 0.84$, $R_q = 1.13$) and G3-bur-finished group ($R_a = 0.89$, $R_q = 1.20$) showed rougher surfaces according to the SEM images. G4-polished group SEM images showed a smooth surface, but it was not as shiny as for the G2-glazed group. SEM images for the four groups are shown in Figure 29, Figure 30, Figure 31, and Figure 32.

THE EFFECT OF WEAR ON ZIRCONIA SLIDER HEIGHT LOSS

For HA antagonists, glazed zirconia sliders had significantly more slider height loss ($35.39 \mu\text{m}$) than as-machined ($12.70 \mu\text{m}$) ($p < 0.0001$), bur-finished ($16.34 \mu\text{m}$) ($p = 0.0005$), and polished zirconia sliders ($6.61 \mu\text{m}$) ($p < 0.0001$).

Polished zirconia sliders presented significantly less height loss ($6.61 \mu\text{m}$) than as-machined ($12.70 \mu\text{m}$) ($p = 0.0011$) and bur-finished ($16.34 \mu\text{m}$) ($p = 0.0001$) zirconia sliders. As-machined and bur-finished zirconia sliders did not show significantly different slider height loss ($p = 0.38$) (Table V and Figure 33).

Similarly, for bovine antagonists, polished zirconia sliders demonstrated significantly less height loss ($8.2 \mu\text{m}$) than glazed zirconia sliders ($39.5 \mu\text{m}$) ($p = 0.0001$) (Table V and Figure 34).

The results suggest that regardless of the antagonist material used in this study, the polished zirconia showed the lowest vertical height loss, and the glazed zirconia sliders had the highest vertical height loss, while the as-machined and bur-finished groups presented intermediate values.

THE EFFECT OF ZIRCONIA SURFACE ROUGHNESS ON ANTAGONIST HEIGHT LOSS AND VOLUME LOSS

For HA Antagonists

Polished zirconia sliders caused significantly less antagonist height loss (14.7 μm) and antagonist volume loss (1.3 mm^3) than as-machined (24.7 μm , 2.7 mm^3) ($p = 0.0001$), bur-finished (24.3 μm , 2.5 mm^3) ($p = 0.0001$), and glazed (25.8 μm , 2.7 mm^3) ($p = 0.0001$) zirconia sliders, while as-machined, bur-finished, and glazed zirconia sliders were not significantly ($p > 0.70$) different from each other (Table V, Figure 35 and Figure 36).

For Bovine Antagonists

Similarly, polished zirconia sliders resulted in significantly less antagonist height loss (116.2 μm) ($p = 0.0001$) and antagonist volume loss (17.7 mm^3) ($p = 0.0018$) compared with glazed zirconia sliders (197.6 μm , and 28.5 mm^3) (Table V and Figure 37 and Figure 38).

HA Versus Bovine Antagonists

For glazed and polished zirconia sliders, antagonist height and volume loss were significantly higher for bovine antagonists than for HA antagonists (197.6 μm /116.2 μm ,

and $28.5 \text{ mm}^3/17.7 \text{ mm}^3$ for bovine and HA antagonists, respectively) ($p < 0.0001$). (Table V and Figure 37 and Figure 38).

On the other hand, slider height loss was not significantly different ($p > 0.49$) between glazed/polished zirconia against the different antagonist materials ($39.5 \text{ }\mu\text{m}/8.2 \text{ }\mu\text{m}$ for glazed/polished zirconia against bovine, compared with $35.4 \text{ }\mu\text{m}/6.6 \text{ }\mu\text{m}$ for glazed/polished zirconia against HA) (Table V and Figure 34).

For HA antagonist samples, scanning electron microscopy was performed at X75, X500, and X1500 magnification to study the differences in the characteristics of the worn surfaces (smooth, rough, and presence of cracks or fractures). Images for different groups are shown in Figure 39, Figure 40, Figure 41, and Figure 42. The qualitative information shows differences in the characteristics of the worn surfaces. G1, G2, and G3 caused rougher antagonist surfaces when compared with G4. The roughest surface was associated with the G2-glazed group.

TABLES AND FIGURES

TABLE I
Descriptive statistics for zirconia surface roughness*

Method	Type	Group	N	Mean	SD	SE	Min	Max	
Ra	Zirconia Slider	As-machined	8	0.84 ^A	0.15	0.05	0.60	1.04	
		Bur-finished	8	0.89 ^A	0.12	0.04	0.68	1.07	
		Glazed							
		Bovine	8	0.40 ^B	0.07	0.02	0.30	0.49	
		HA	8	0.42 ^B	0.09	0.03	0.32	0.58	
		Polished							
		Bovine	8	0.49 ^C	0.06	0.02	0.41	0.58	
		HA	8	0.49 ^C	0.05	0.02	0.41	0.57	
Rq	Zirconia Slider	As-machined	8	1.13 ^I	0.20	0.07	0.81	1.39	
		Bur-finished	8	1.20 ^I	0.19	0.07	0.88	1.46	
		Glazed							
		Bovine	8	0.56 ^{II}	0.09	0.03	0.41	0.67	
		HA	8	0.63 ^{II}	0.17	0.06	0.45	0.99	
		Polished							
		Bovine	8	0.73 ^{III}	0.06	0.02	0.63	0.84	
		HA	8	0.76 ^{III}	0.06	0.02	0.69	0.89	

*Ra/Rq values for groups with the same superscript letter/number were not significantly different.

TABLE II

Descriptive statistics for zirconia height loss*

	Zirconia Slider	Antagonist	N	Mean	SD	SE	Min	Max
Slider Height Loss (μm)	As-machined	HA	8	12.7 ^A	1.8	0.6	9.6	15.4
	Bur-finished	HA	8	16.3 ^A	6.5	2.3	6.9	27.1
	Glazed	Bovine	8	39.5 ^B	11.2	4.0	20.4	52.8
	Glazed	HA	8	35.4 ^B	12.5	4.4	22.9	57.6
	Polished	Bovine	8	8.2 ^C	5.1	1.8	2.4	18.6
	Polished	HA	8	6.6 ^C	2.8	1.0	2.5	9.9

*Groups with the same superscript letter were not significantly different.

TABLE III

Descriptive statistics for antagonist height loss*

	Zirconia Slider	Antagonist	N	Mean	SD	SE	Min	Max
Antagonist Height Loss (μm)	As-machined	HA	8	24.7 ^A	4.6	1.6	15.7	30.8
	Bur-finished	HA	8	24.3 ^A	3.5	1.2	17.5	29.2
	Glazed	Bovine	8	197.6 ^B	66.0	23.3	144.9	352.2
	Glazed	HA	8	25.8 ^A	7.7	2.7	16.7	41.5
	Polished	Bovine	8	116.2 ^C	28.1	9.9	75.5	153.7
	Polished	HA	8	14.7 ^D	3.3	1.2	9.7	20.8

*Groups with the same superscript letter were not significantly different.

TABLE IV
Descriptive statistics for antagonist volume loss*

	Zirconia Slider	Antagonist	N	Mean	SD	SE	Min	Max
Antagonist Volume Loss (mm ³)	As-machined	HA	8	2.7 ^A	0.6	0.2	1.6	3.3
	Bur-finished	HA	8	2.5 ^A	0.5	0.2	1.9	3.3
	Glazed	Bovine	8	28.5 ^B	12.2	4.3	19.4	57.3
	Glazed	HA	8	2.7 ^A	1.1	0.4	1.9	4.9
	Polished	Bovine	8	17.7 ^C	3.0	1.1	12.9	22.1
	Polished	HA	8	1.3 ^D	0.3	0.1	0.9	1.8

*Groups with the same superscript letter were not significantly different.

TABLE V

One-way ANOVA comparing different groups

Outcome	Effect	NumDF	DenDF	FValue	ProbF
Slider Ra (μm)	Zirconia Slider*Antagonist	5	42	37.52	1.91E-14
Slider Rq (μm)	Zirconia Slider*Antagonist	5	42	27.93	2.40E-12
Antagonist Ra (μm)	Zirconia Slider*Antagonist	5	42	13.8	5.51E-08
Antagonist Rq (μm)	Zirconia Slider*Antagonist	5	42	26.57	5.26E-12
Slider Height Loss (μm)	Zirconia Slider*Antagonist	5	42	26.66	4.98E-12
Antagonist Height Loss (μm)	Zirconia Slider*Antagonist	5	42	148.77	1.41E-25
Antagonist Volume Loss (mm^3)	Zirconia Slider*Antagonist	5	42	185.2	1.80E-27



FIGURE 1. FCZ zirconia disk as provided by the manufacturer (Ardent Dental Inc., NY) to be cut into blocks for further milling with the CAD/CAM milling unit.

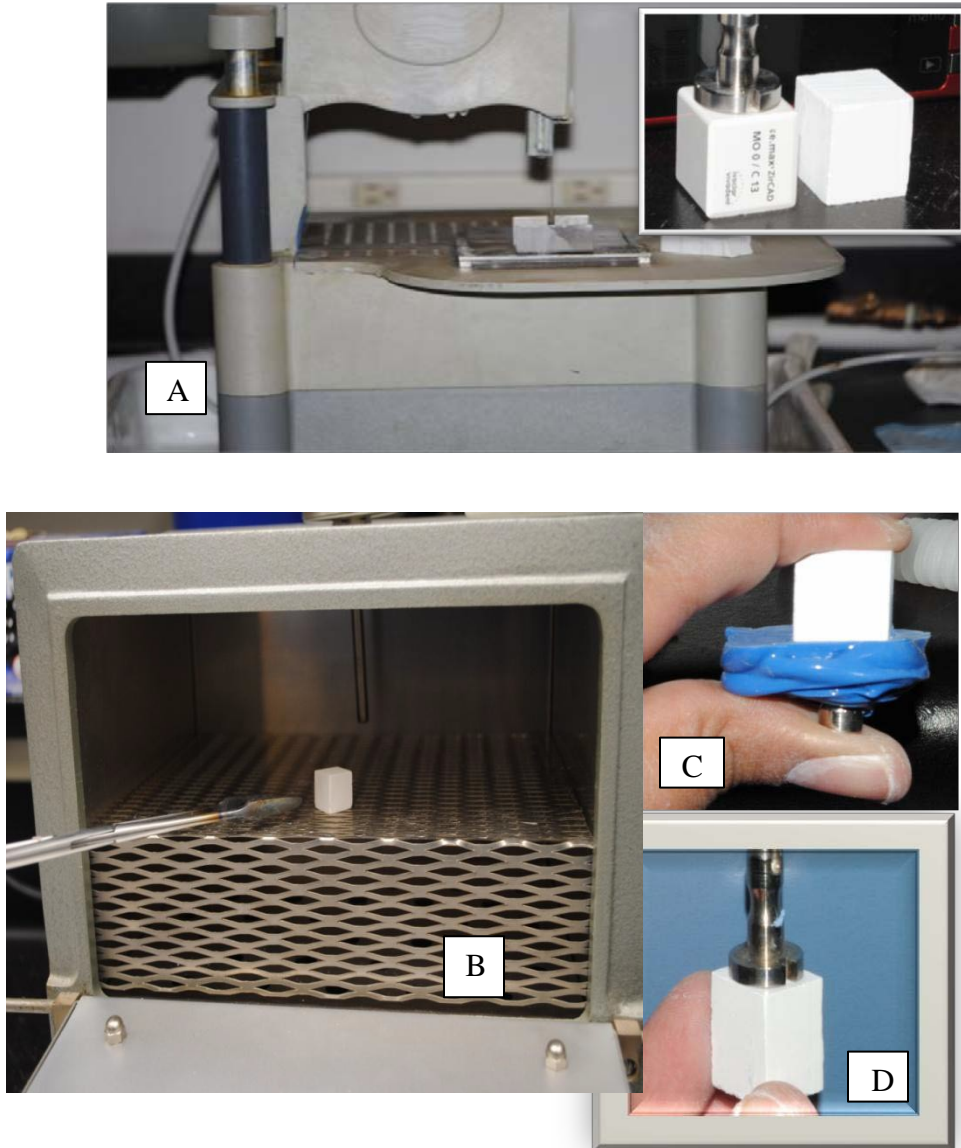

FIGURE 2. Zirconia blocks preparation steps for CAD/CAM milling. A) Cutting band saw used for zirconia block sectioning (inset represents the prepared block adjacent to a premade Zir-Cad sample from Ivoclar-Vivadent. B) Furnace used for moisture removal. C) Jig used to attach the CAD/CAM pin to the zirconia sample, and D) Specimen ready to be inserted in the CAD/CAM milling unit.



FIGURE 3. CAD/CAM milling facility at Ivoclar-Vivadent labs, Buffalo, NY. A) Computer, scanner, and software required for scanning and designing a restoration. B) The milling unit used for sample preparation according to the computer design.



FIGURE 4. Zirconia sliders fabrication using CAD/CAM machine. A) Metal pattern prepared to be scanned by the CAD/CAM machine. B) The zirconia samples milled by the machine according to the scanned metal pattern. C) Zirconia specimens ready to be sintered.

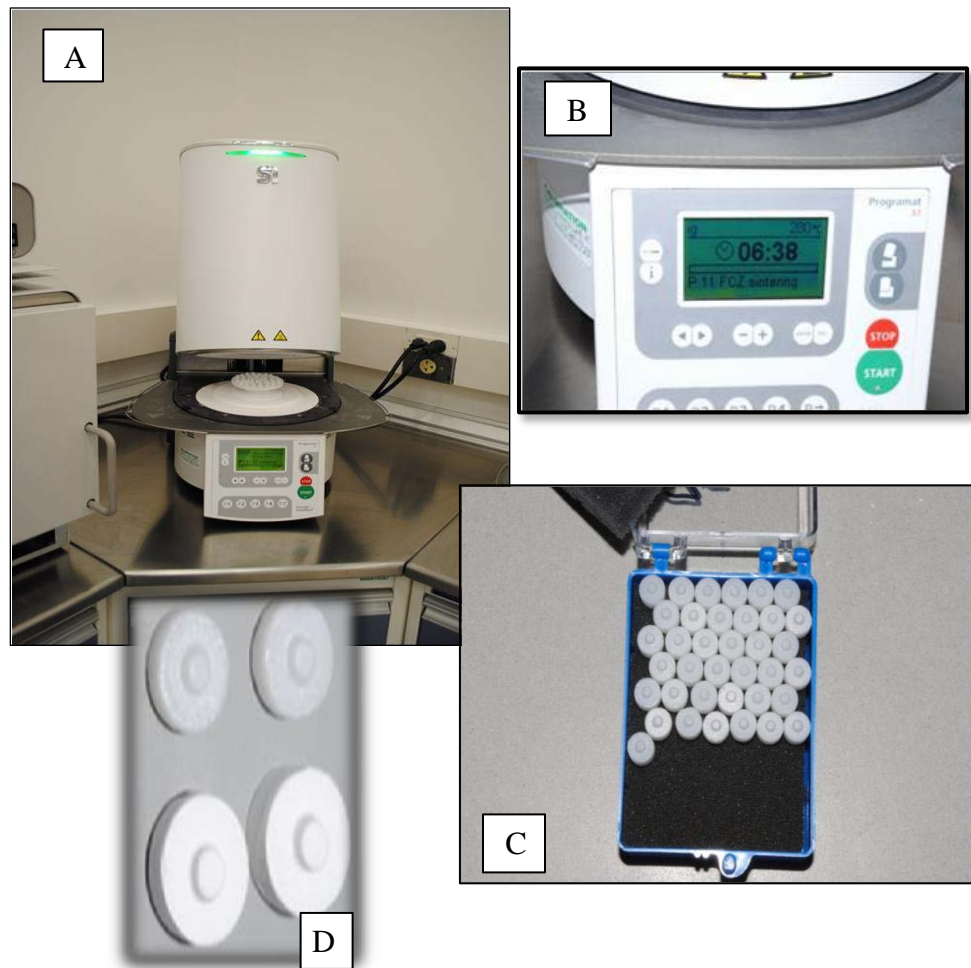

FIGURE 5. Sintering. A) Sintering furnace used. B) Sintering furnace screen showing sintering parameters. C) Fully sintered zirconia sliders. D) Zirconia shrinkage after sintering. The upper samples are fully sintered compared with the lower samples, which are not.

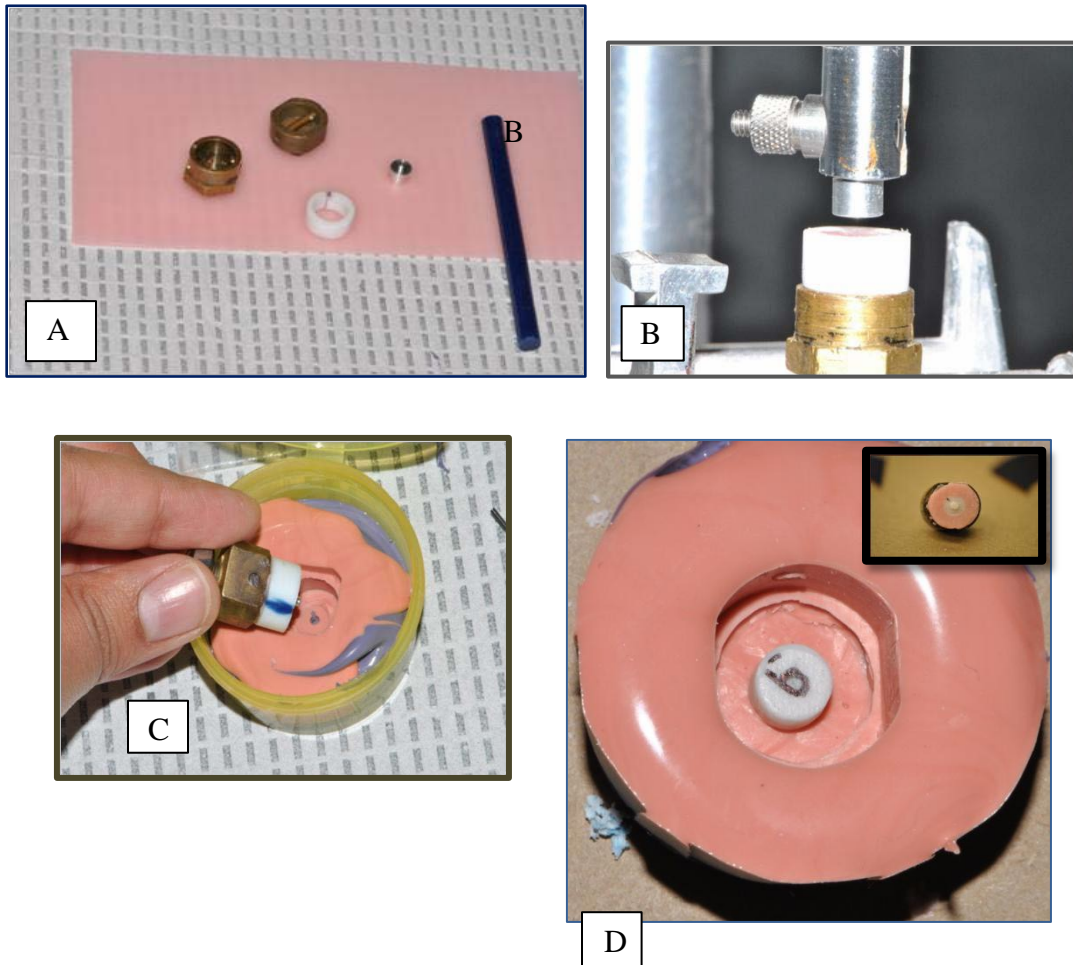

FIGURE 6. Zirconia mounting jig fabrication and mounting steps. A) The materials used for fabrication of the jig, (wax, metal specimen, plastic sleeve and brass holders.) B) A dental surveyor was used to mount the metal specimen inside the wax-filled cylinder; care was taken to make sure the tip of the slider specimen was parallel to the floor. C) The mounting jig was fabricated with silicone impression material. D) The zirconia slider in position in the jig ready for mounting (inset shows the final specimen after being embedded in acrylic resin).

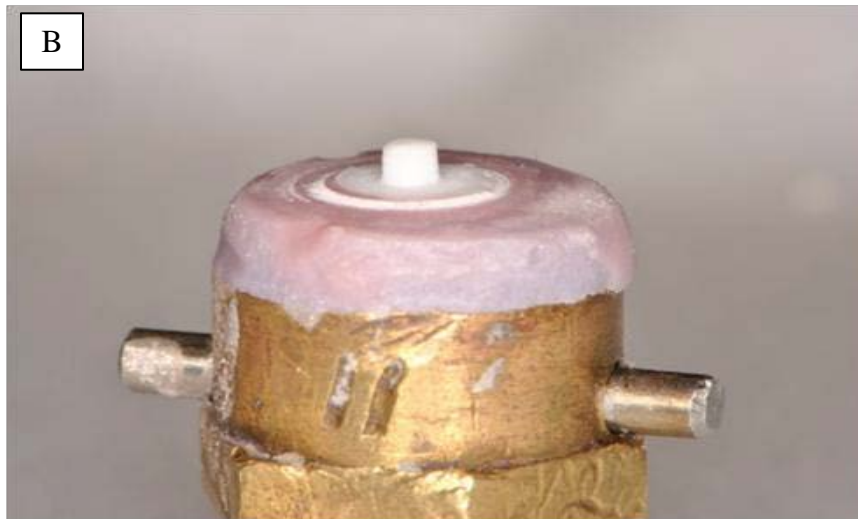
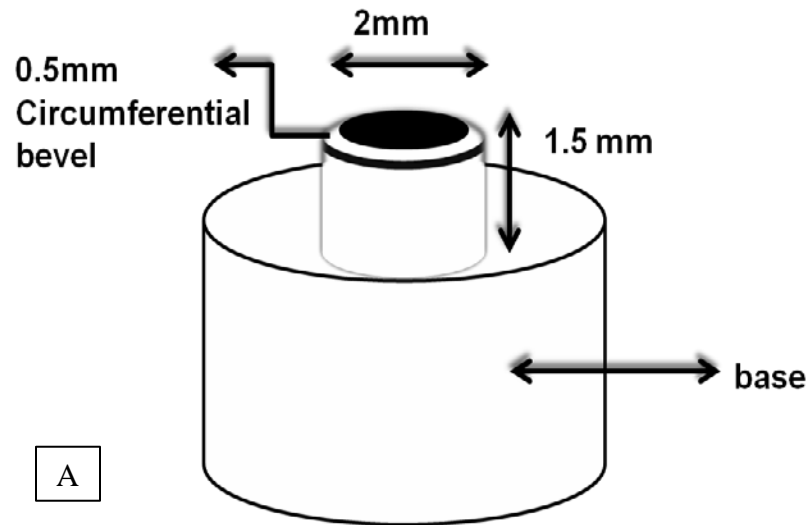
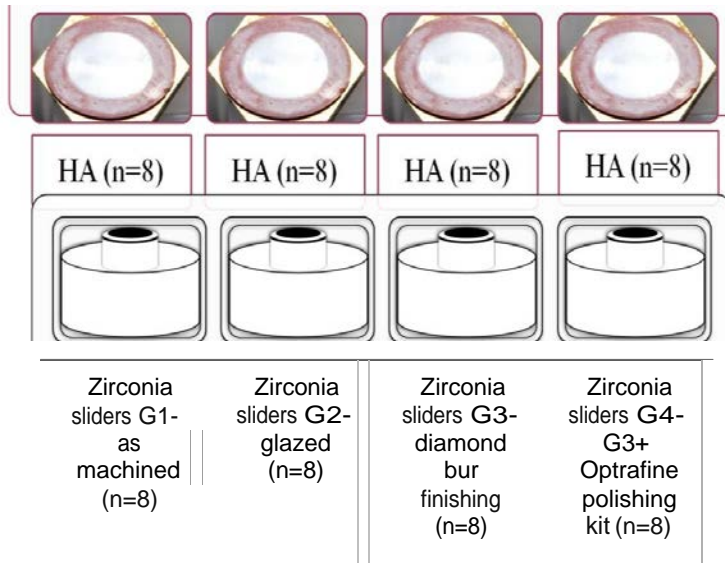

FIGURE 7. A) Schematic representation of zirconia slider showing the shape and dimensions of the slider. B) A mounted slider specimen with the slider tip extending above the mounting acrylic.

Part one study



Part two study

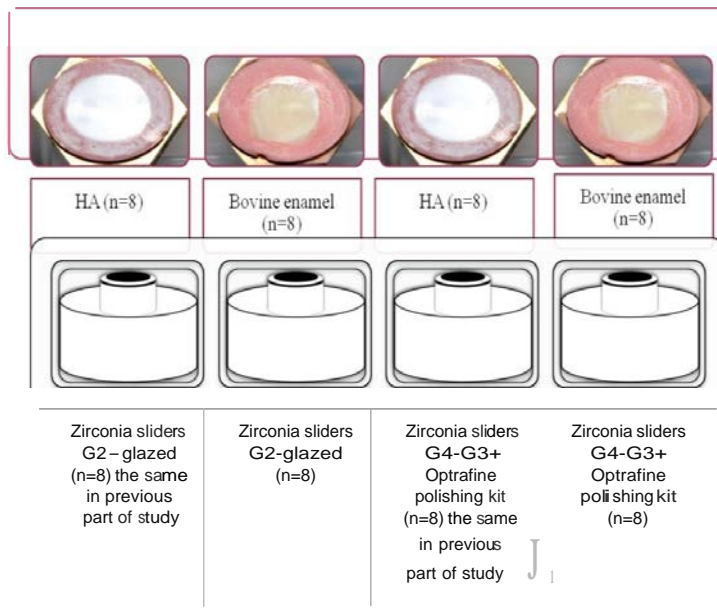

FIGURE 8. Schematic representation of the experimental groups tested.

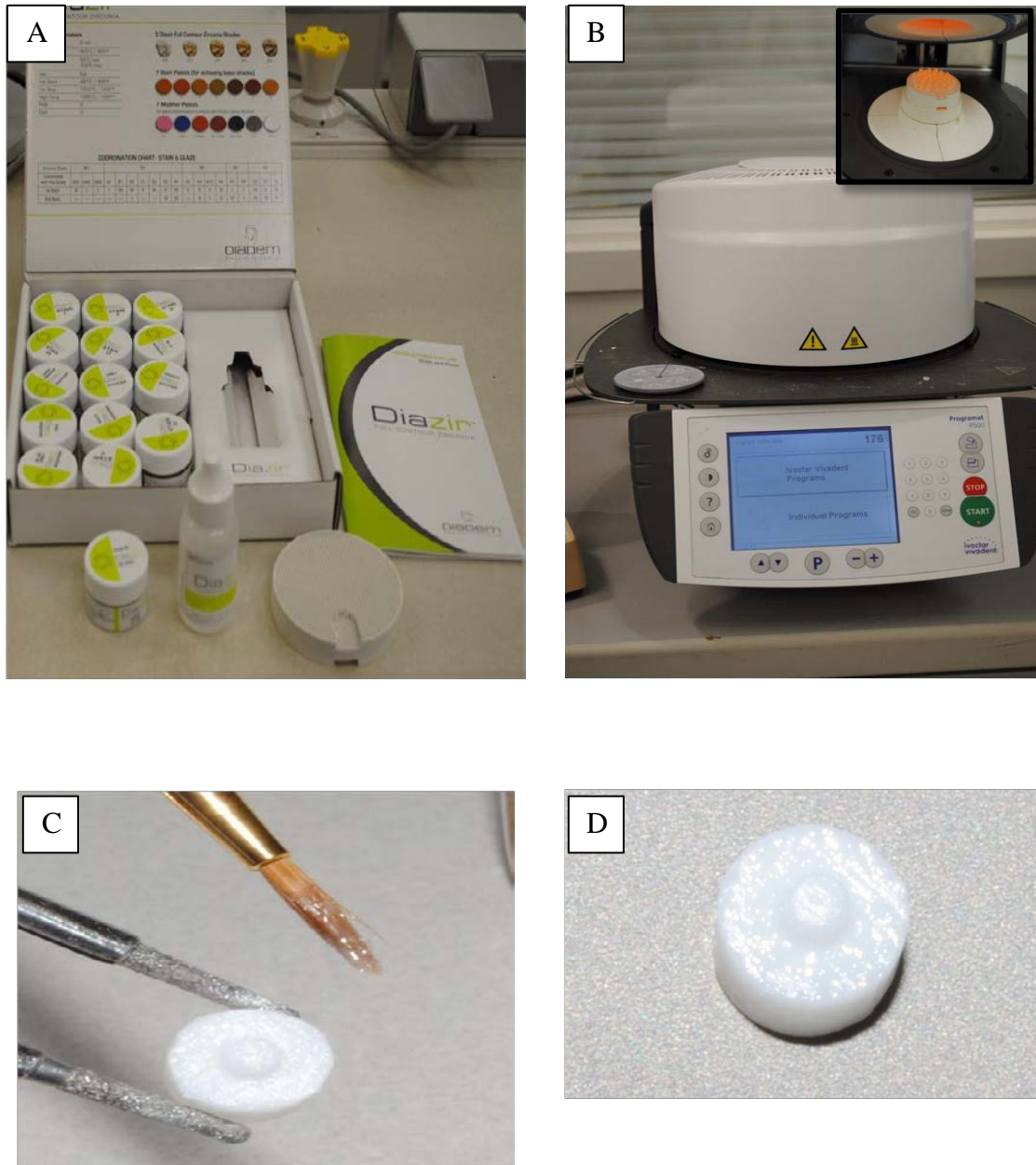

FIGURE 9. Glaze application to the zirconia sliders (Group 2). A) Diazir glaze. B) Glazing furnace (inset shows zirconia sliders after being placed in the furnace). C) Glaze application on the slider surface. D) Glazed slider.

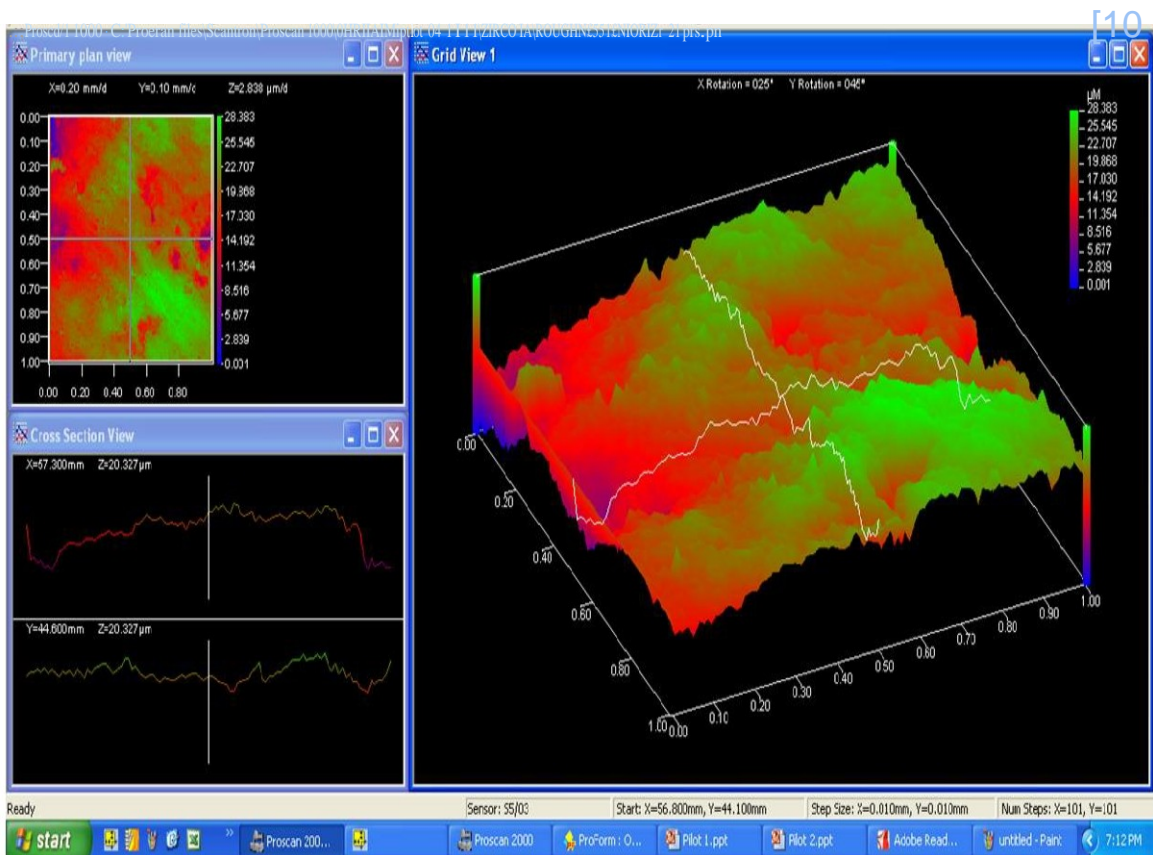

FIGURE 10. Original scan of Zirconia surface taken by Proscan 2000 profilometer using S5/03 sensor, with a step size of 0.01 for both x and y axis, frequency (Hz)= 100, and scanned area of 0.8 x 0.8 mm.

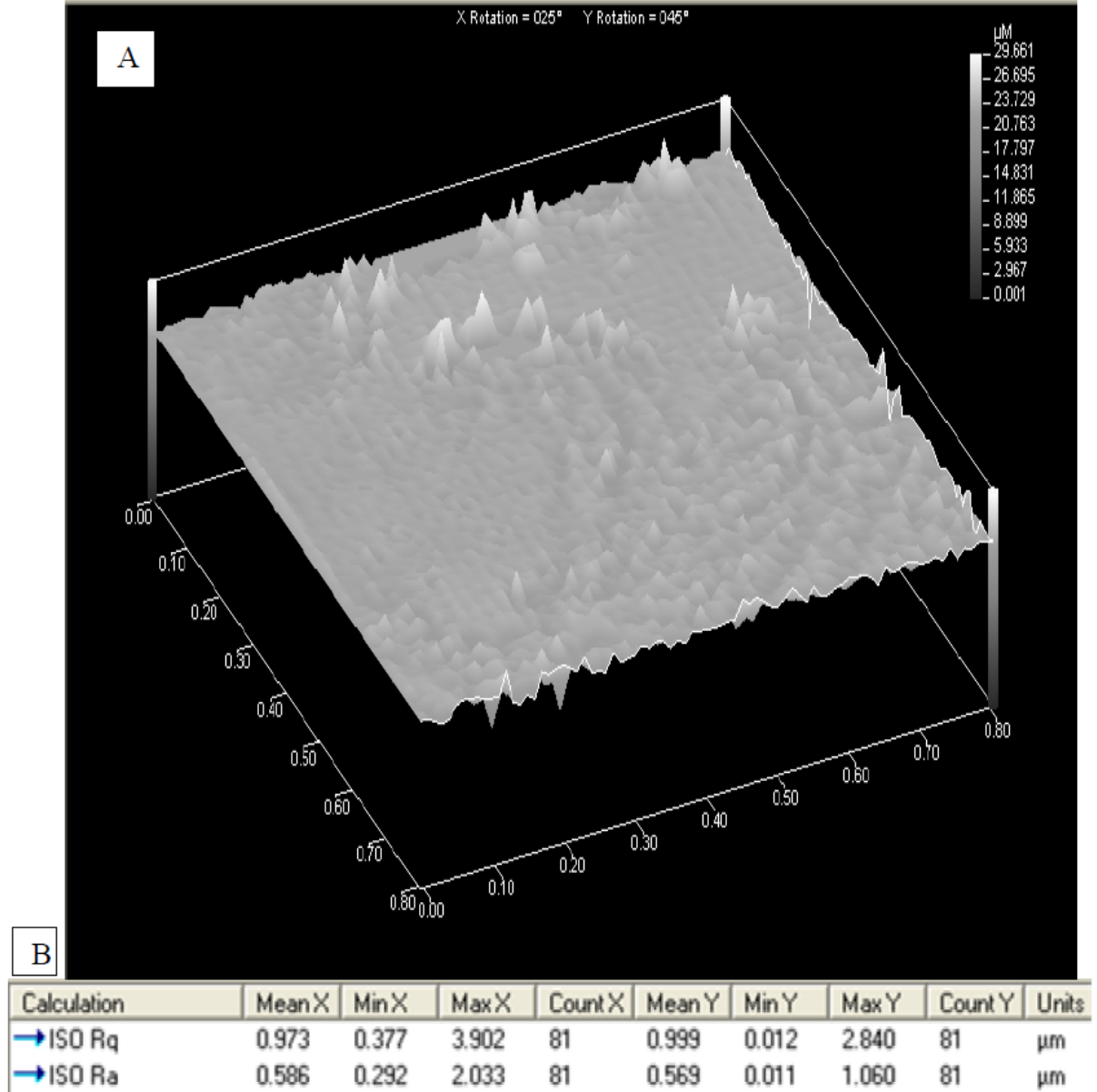
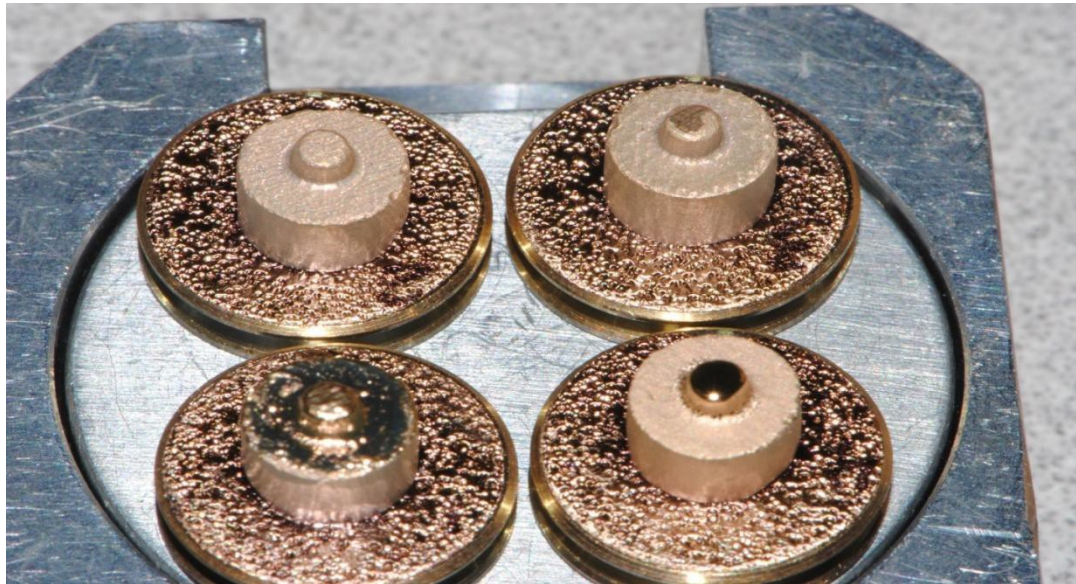
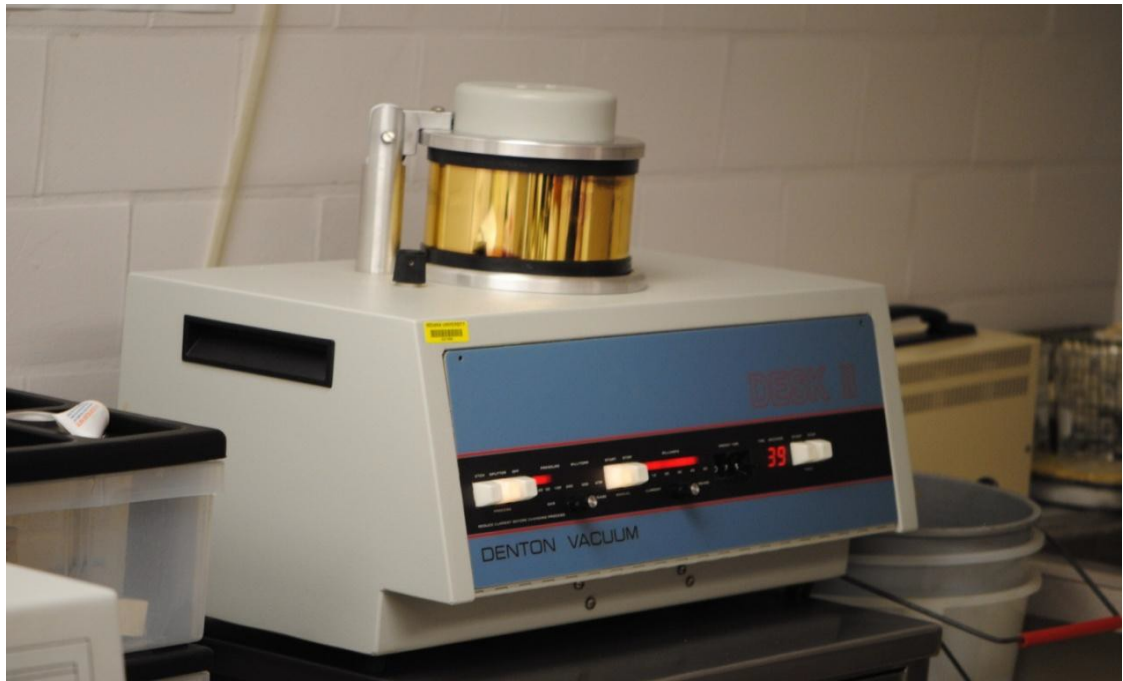

FIGURE 11. A) Zirconia surface scan after processing by the Proscan software; outlier points have been removed, and color scale has been changed to gray. B) Generated roughness measurements.

A



B

FIGURE 12 A) Sputter-coater (Denton Vacuum Desk II) and B) Zirconia samples sputter-coated with gold prior to SEM imaging.

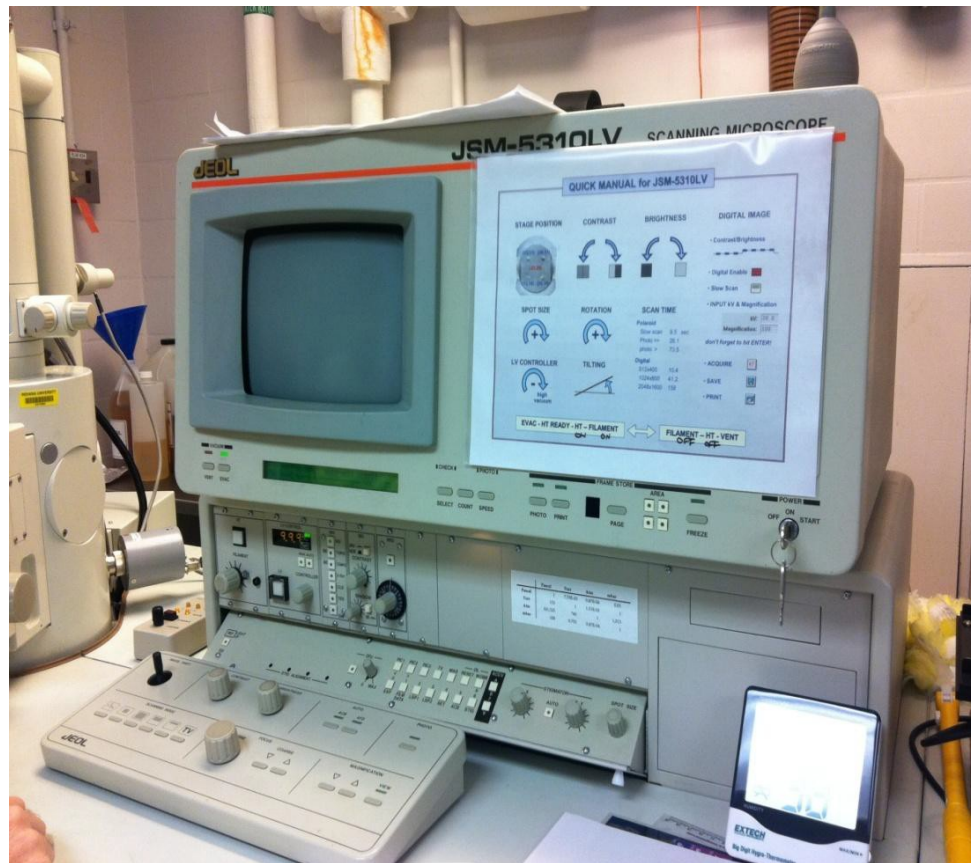

FIGURE 13. Low-vacuum scanning electron microscope (LV SEM).

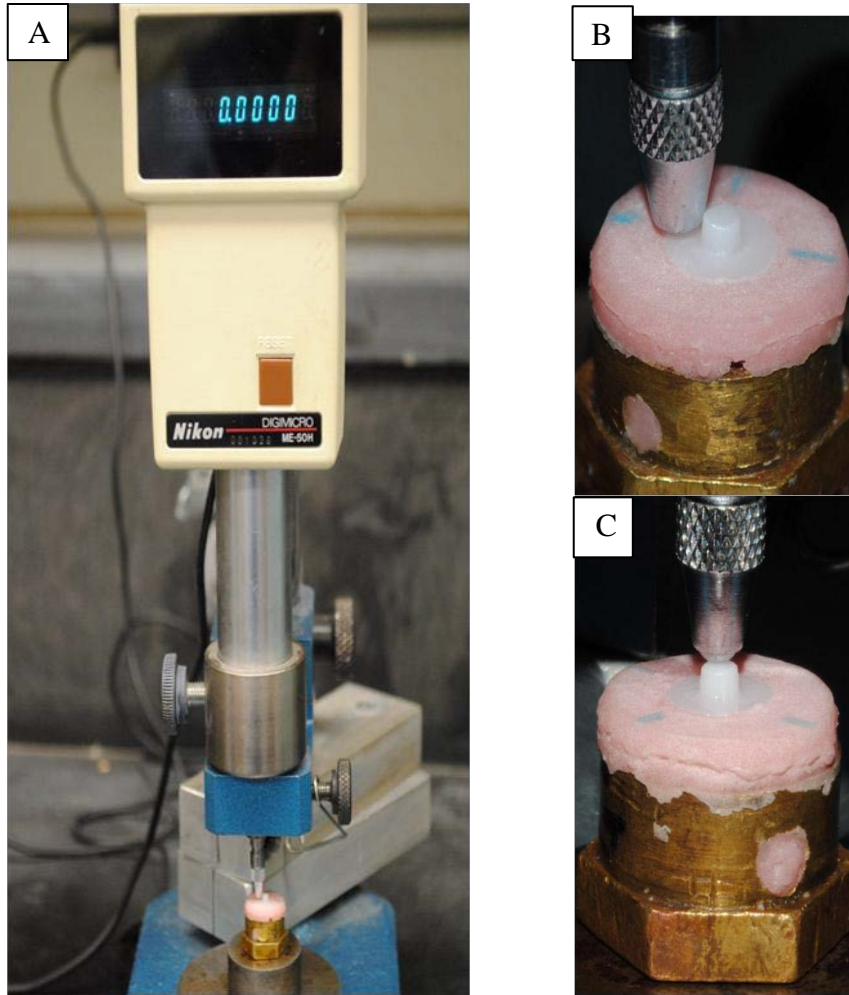

FIGURE 14. Baseline vertical height measurements for zirconia samples taken by digital micrometer. A) Nikon DigiMicro micrometer. B) Reference point selection; four reference points were placed on the surface of the slider base; after selecting the reference point, the micrometer reading was set to zero. C) After establishing a reference point, the tip of the micrometer was positioned over the slider tip to give a reading of the slider height.

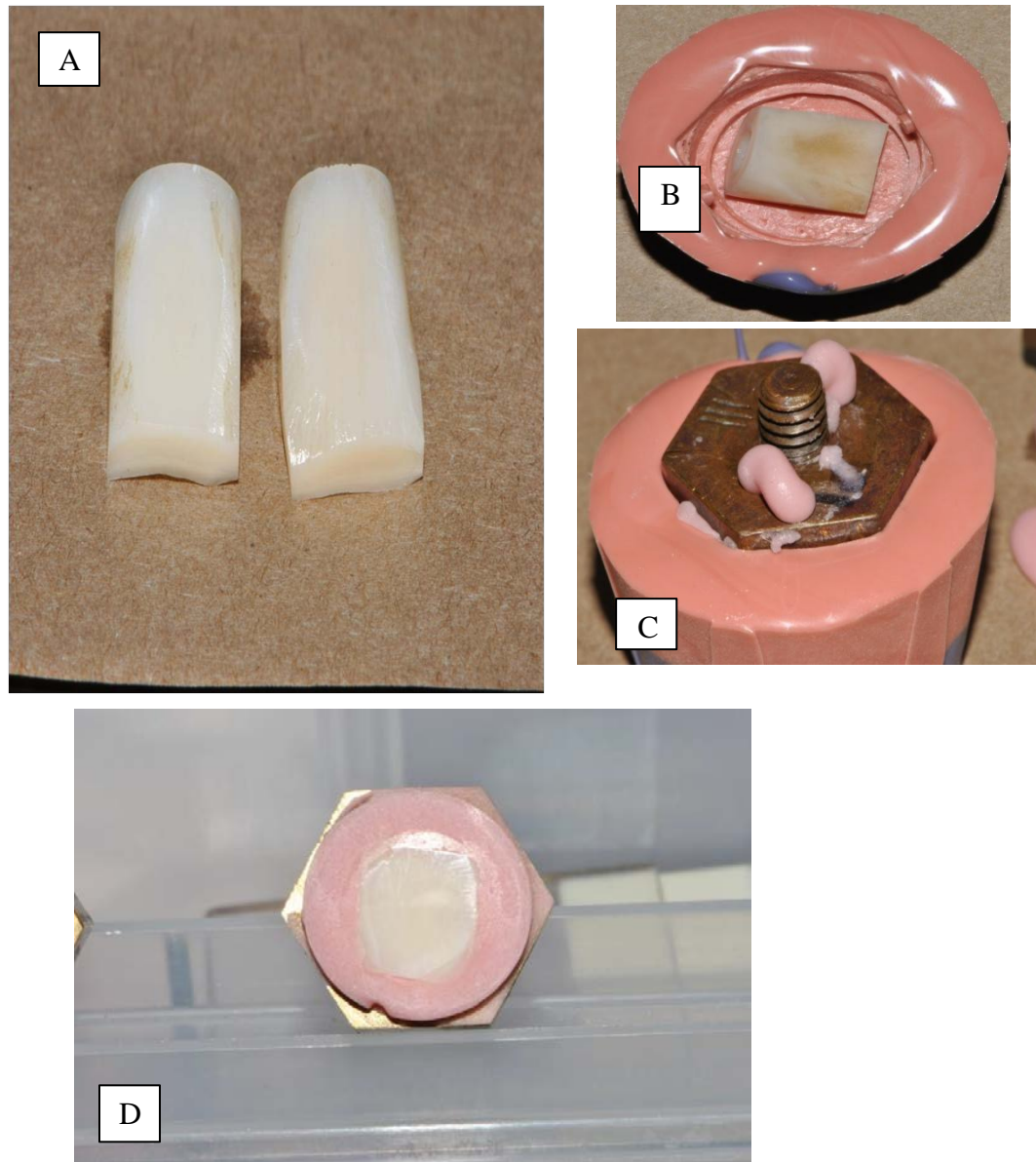

FIGURE 15. Bovine teeth preparation and mounting steps. A) Bovine incisors were prepared to have a square shaped facial surface. B) A bovine enamel sample was placed inside a custom made mold. C) Auto-cured acrylic resin was used to embed the bovine specimen inside the brass holder. D) Final specimen after polishing.

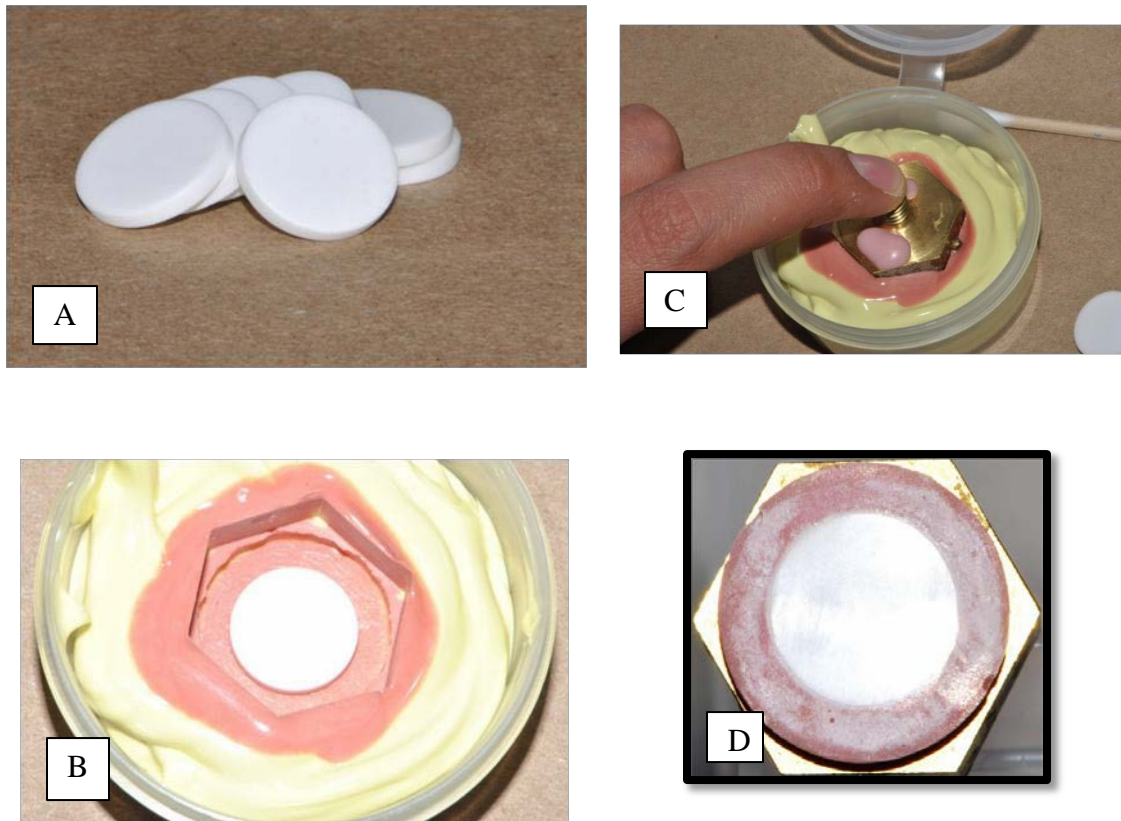

FIGURE 16. Hydroxyapatite mounting steps. A) HA disks. B) HA sample placed inside a custom made mold. C) Auto-cured acrylic resin was used to embed the HA specimen inside the brass holder. D) Final specimen after polishing.

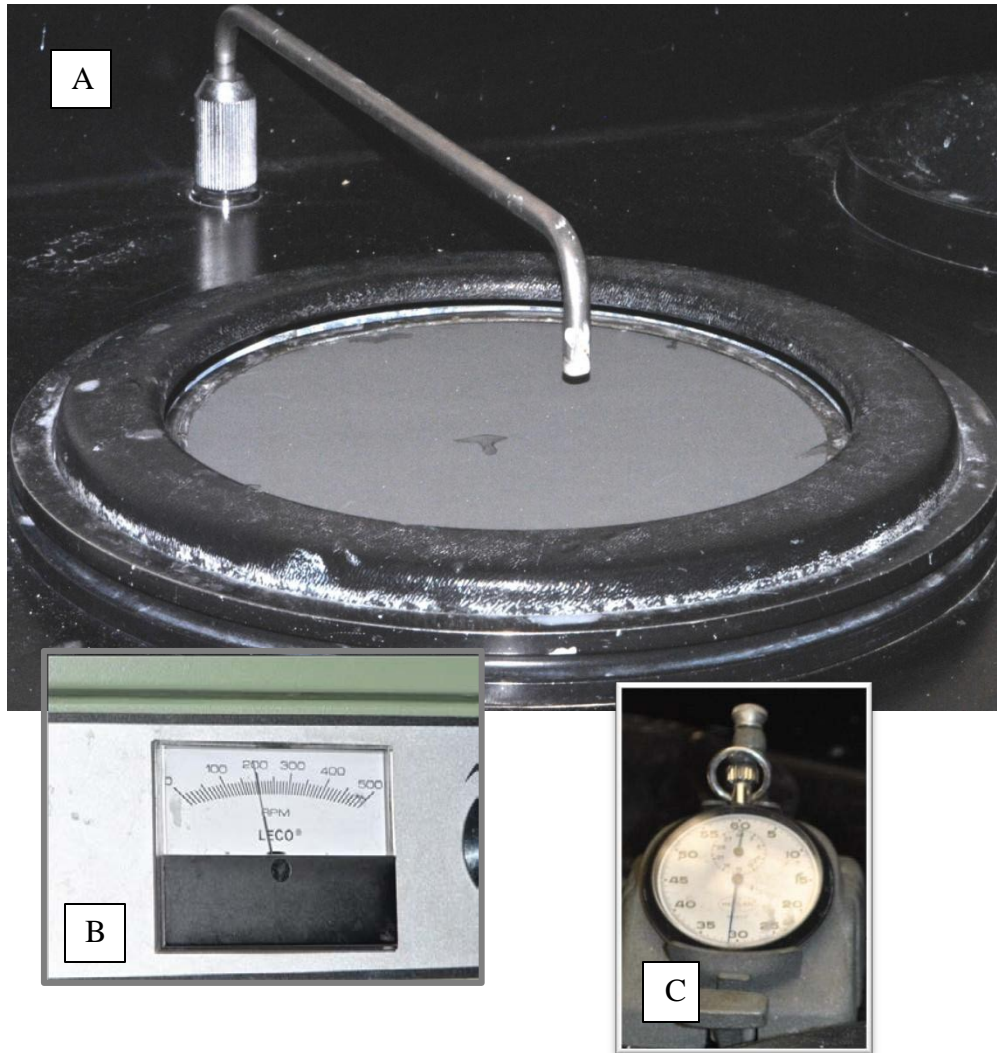

FIGURE 17. Polishing HA and bovine samples. A) Rotary polishing wheel used for polishing the samples. B) The speed of the wheel used as 200 RPM. C) Each polishing step was carried out for 30 s, and then samples were cleaned with ethanol and water. Three different grits of SiC papers were used (600, 800 and 1200).

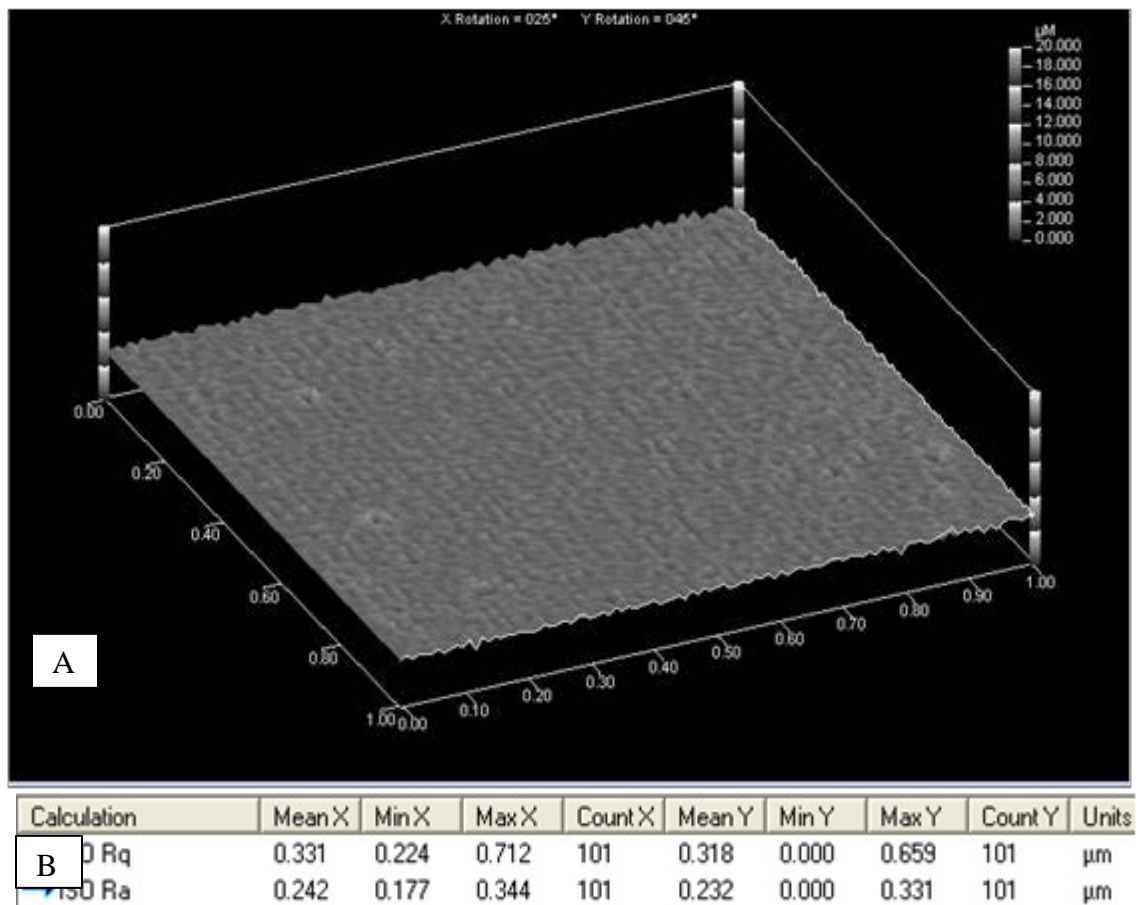
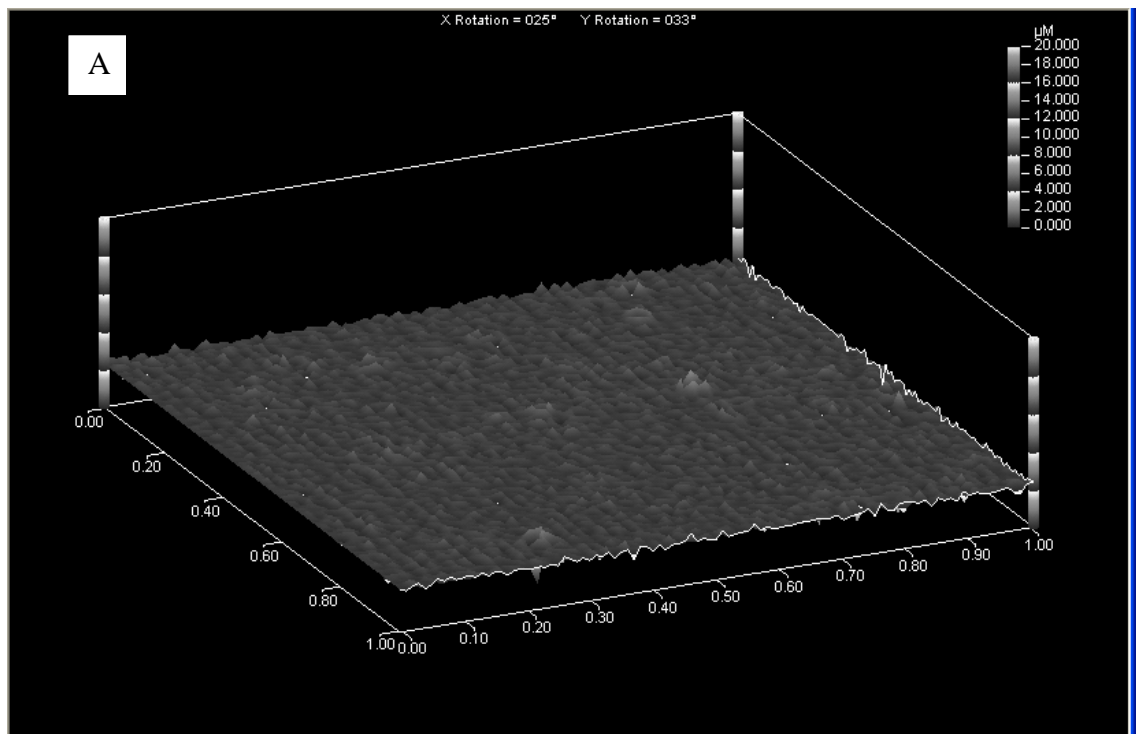

FIGURE 18. A) HA surface scan provided by the Proscan. B) Generated roughness measurements. Due to the large surface area of the specimen, three scans of three different areas were taken for each sample.



Calculation	Mean X	Min X	Max X	Count X	Mean Y	Min Y	Max Y	Count Y	Units
→ ISO Rq	0.377	0.272	0.701	101	0.358	0.001	0.731	101	μm
→ ISO Ra	0.268	0.197	0.413	101	0.252	0.001	0.459	101	μm

B

FIGURE 19. A) Bovine enamel surface scan provided by the Proscan. B) Generated roughness measurements due to the large surface area of the specimen; three scans of three different areas were taken for each sample.

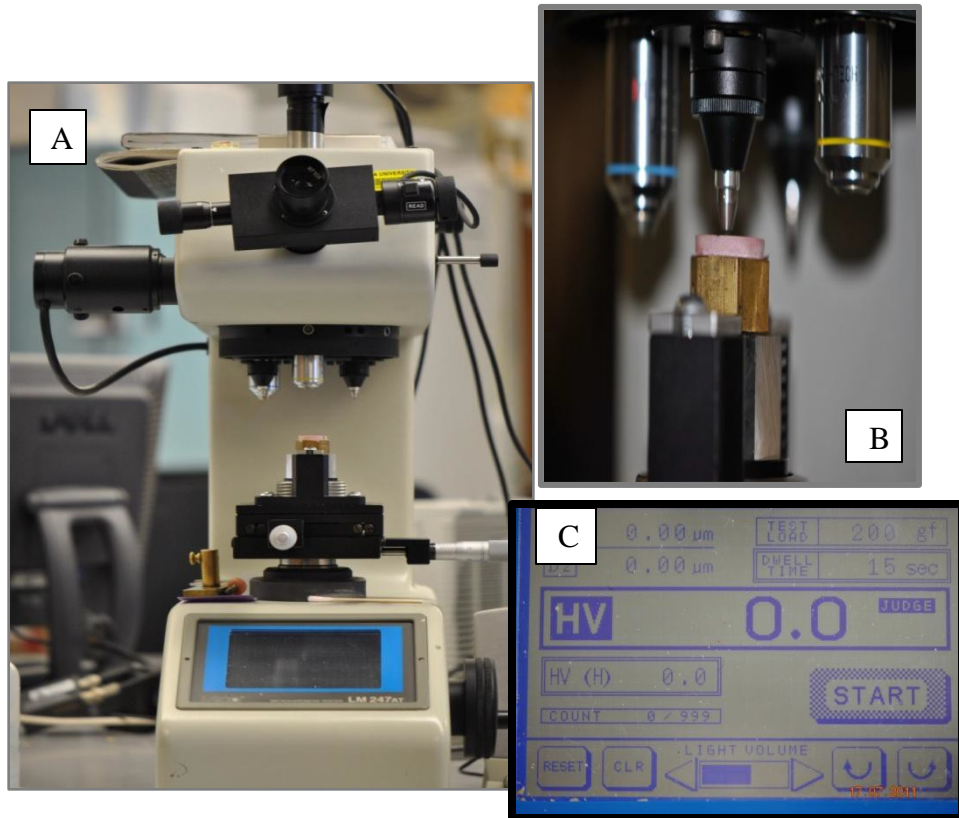

FIGURE 20. Hardness test and parameters. A) Vickers hardness testing machine. B) A closer picture for the specimen while placed inside the machine. C) Control screen of the hardness machine shows the parameter used. A load of 200 g for 15 s was applied, and then computer software was used to calculate the Vickers hardness. For HA specimens, hardness measurements were made at five points per sample and the average was considered the hardness for that sample. For bovine enamel, 15 points per sample were used for hardness measurements. An average Vickers hardness number below 270 resulted in sample exclusion from the study.

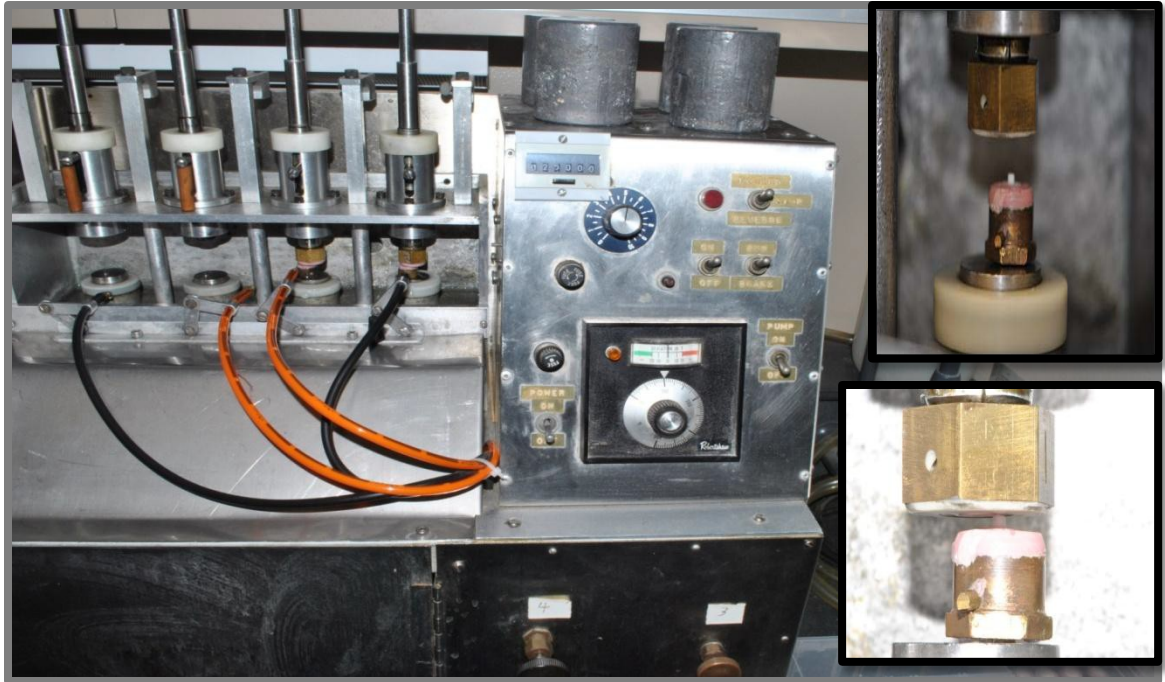

FIGURE 21. Two-body pin-on-disk machine, and wear testing parameters. Wear test was carried out for 25,000 cycles, at 1.2 Hz, using a weight of 49 N. Room temperature water was used continuously for lubrication purposes.

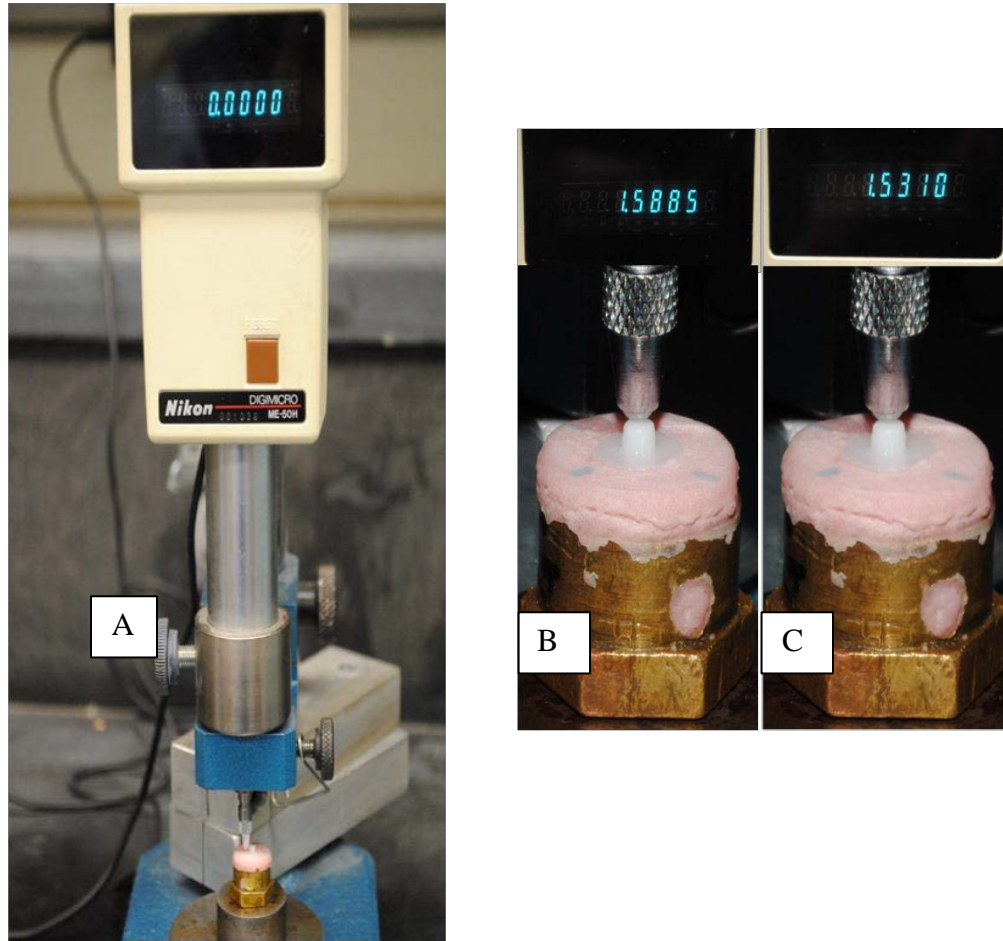

FIGURE 22. Zirconia vertical height loss measurements. A) Nikon DigiMicro micrometer. B) Baseline vertical height of zirconia samples before wear (inset shows an example of such measurement). C) After-wear vertical height measurements (inset shows the after-wear reading for the same sample). Reading given by micrometer is in millimeters. Vertical height loss was measured by subtracting the two values and then converting the result from mm to μm .

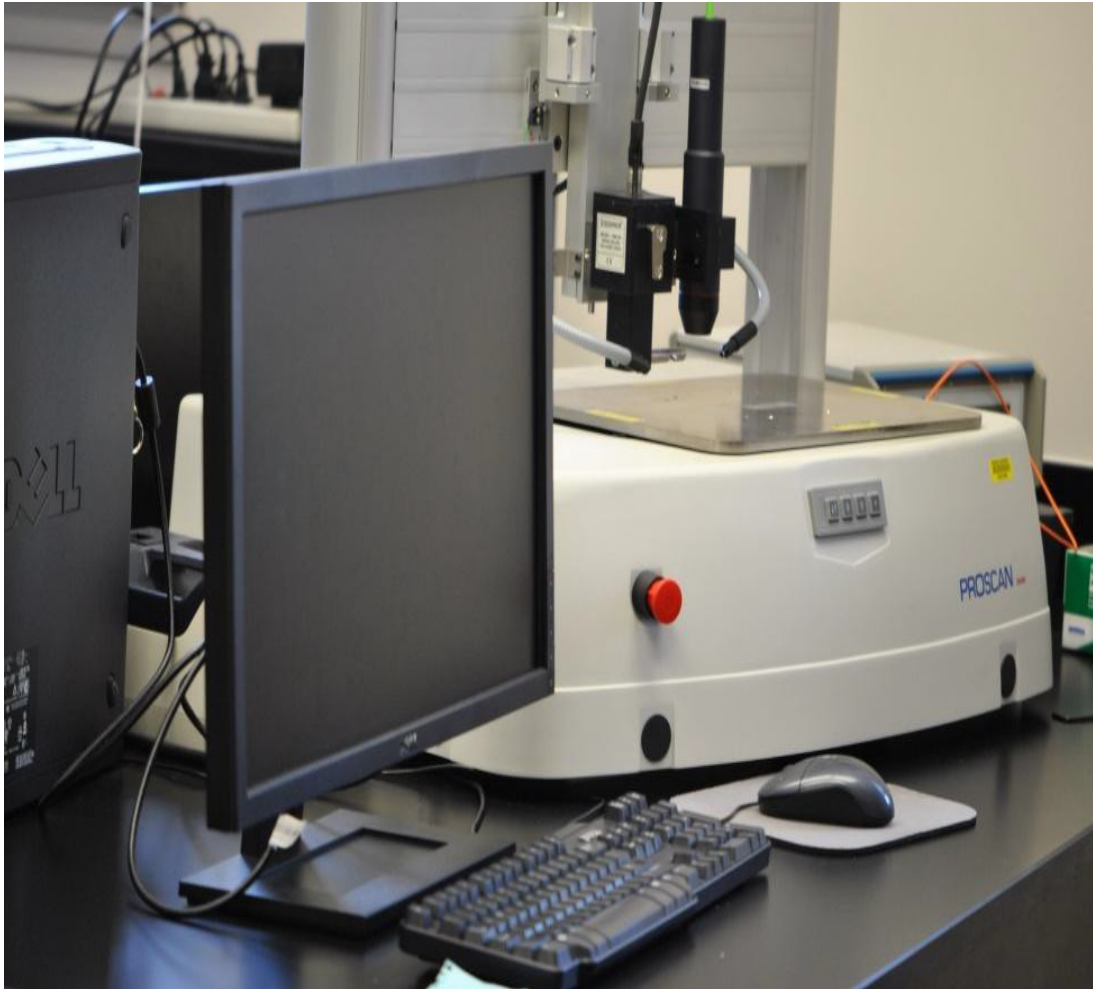

FIGURE 23. Non-contact profilometer - Proscan 2000 (Scantron, Taunton, England).

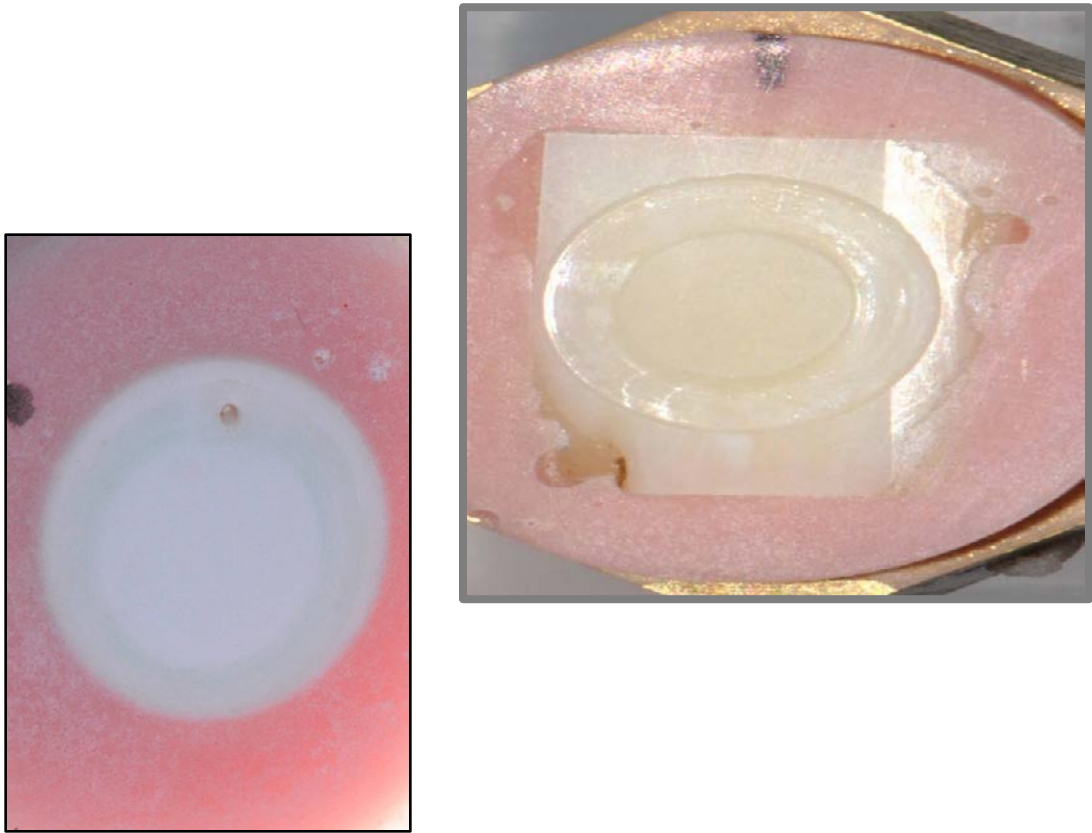

FIGURE 24. Wear track formed on HA (left) and bovine (right).

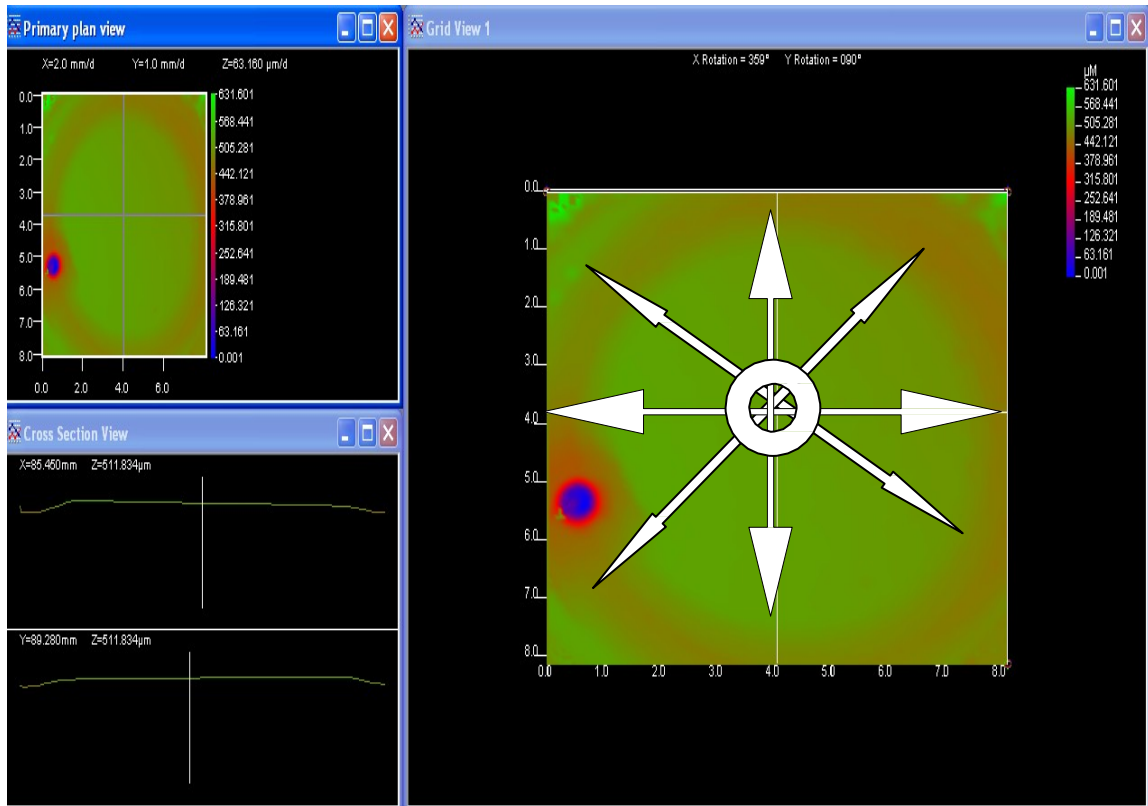

FIGURE 25. Vertical height loss measurements. Using Proscan software, antagonist (HA and bovine) specimen surfaces were scanned after wear testing. Then, for each specimen, the software computed the vertical height loss. Eight areas were selected and their vertical heights were compared with the vertical height of the central unworn area using two-point difference height function. The mean average of the eight vertical high differences was recorded as the vertical high loss for those specimens.

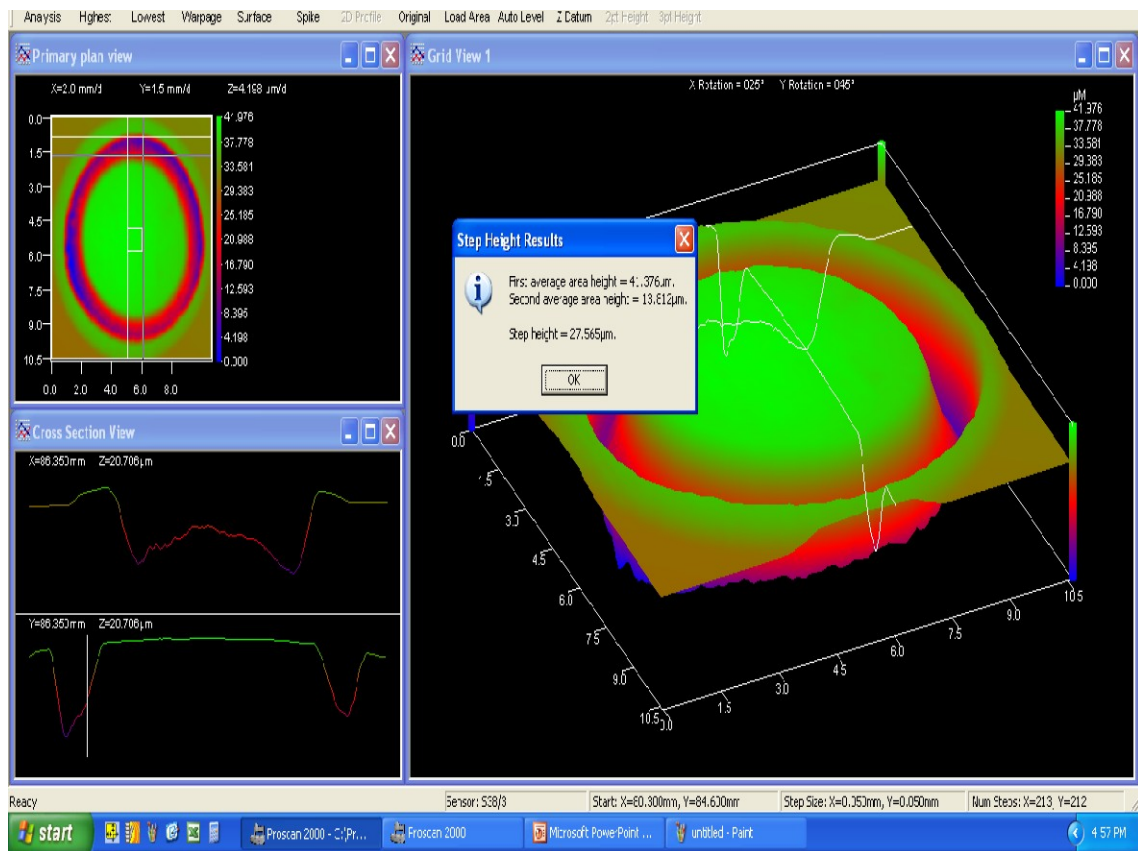

FIGURE 26. Example of vertical height loss.

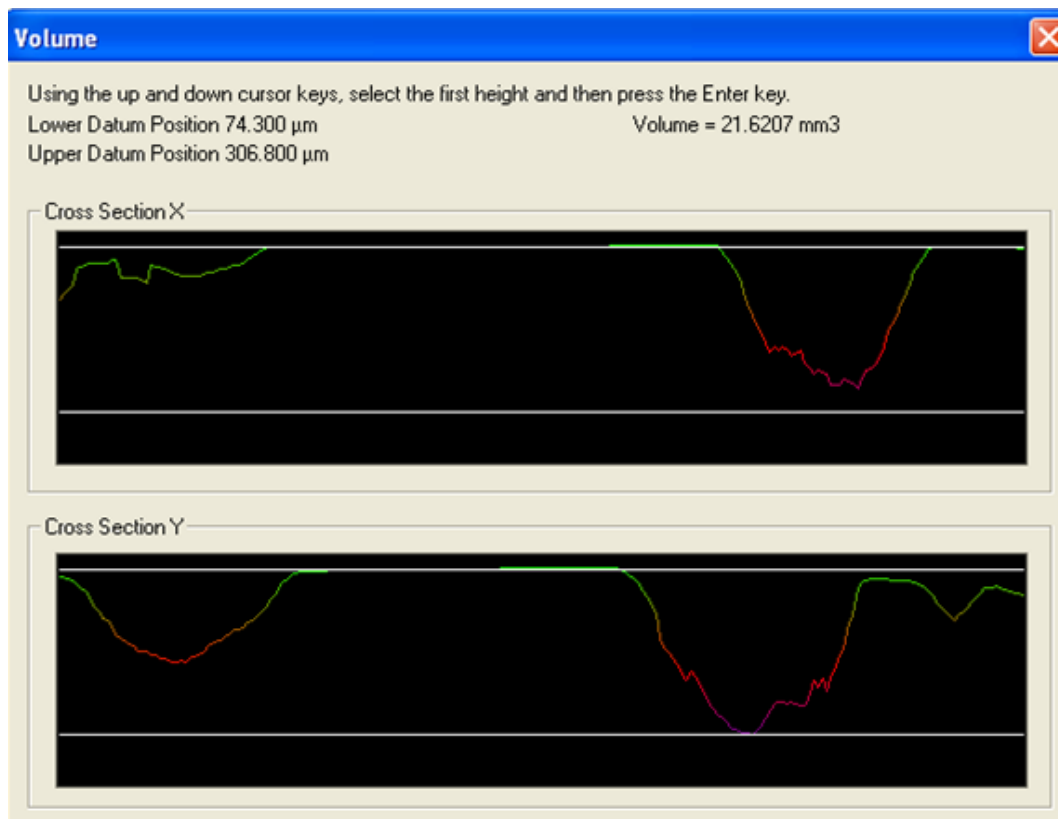

FIGURE 27. Volume loss measurement by Proscan software; using the same after-wear scan for each sample; volume loss was measured by the software. The volume loss represents the volume differences between central area (unworn area) and the deepest part on the wear track. Three different areas were chosen, and six readings were taken along x and y axes; then, the averages were taken.

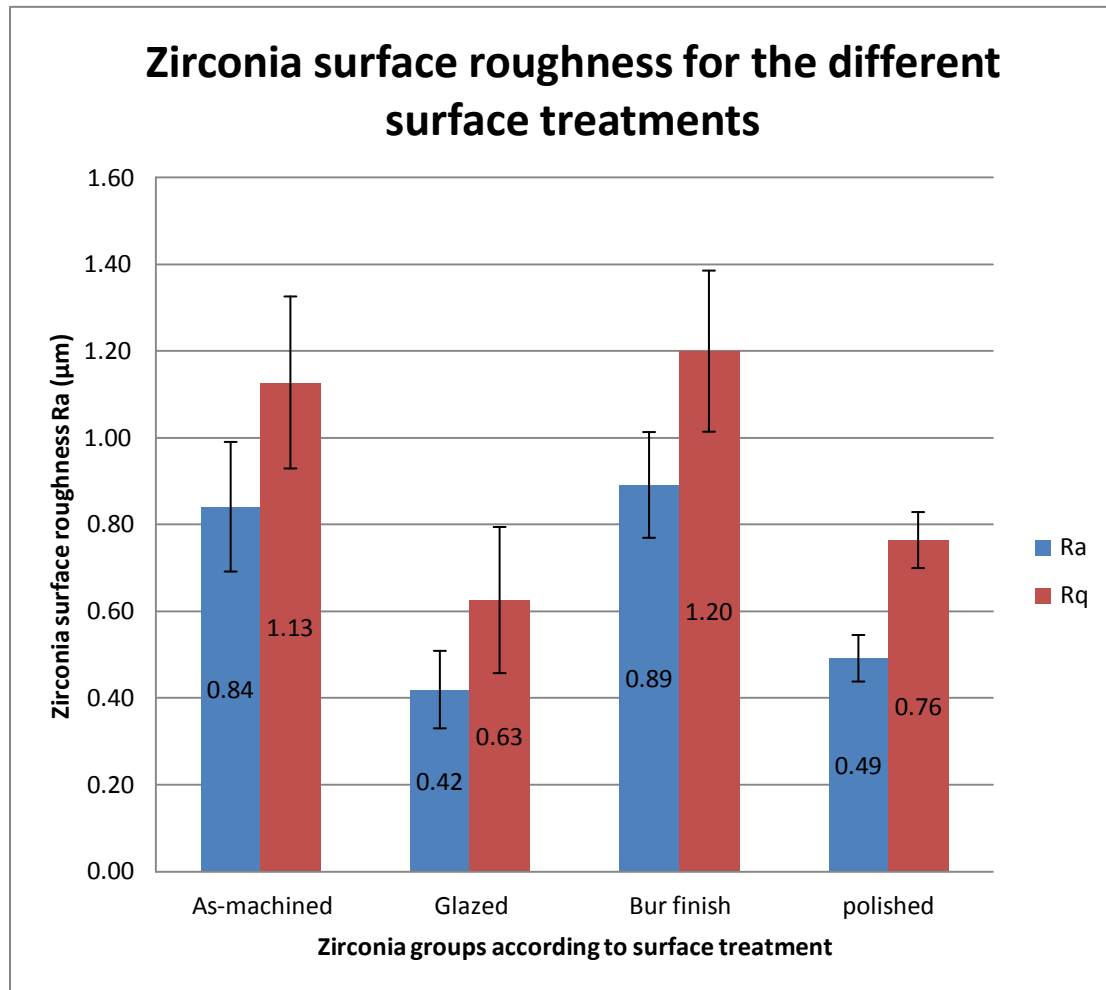

FIGURE 28. Zirconia surface roughness values (Ra and Rq in μm) before wear testing for the different groups along with standard deviation.

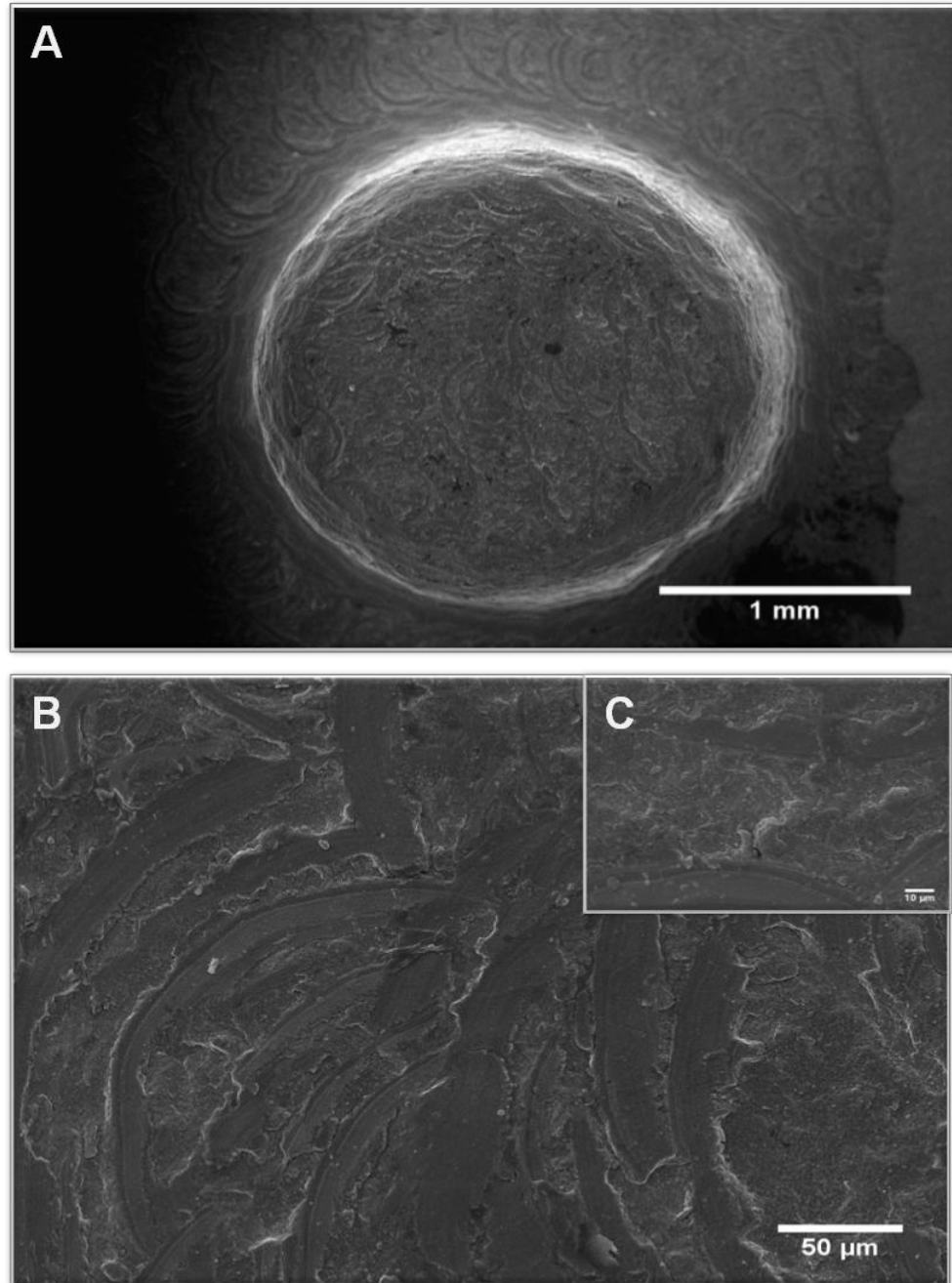

FIGURE 29. SEM micrographs at different magnifications (A) X50; (B) X500 and (C) X1500 for group 1 (as-machined zirconia sliders). The surface appears rough with circular irregularities due to bur movement during milling process.

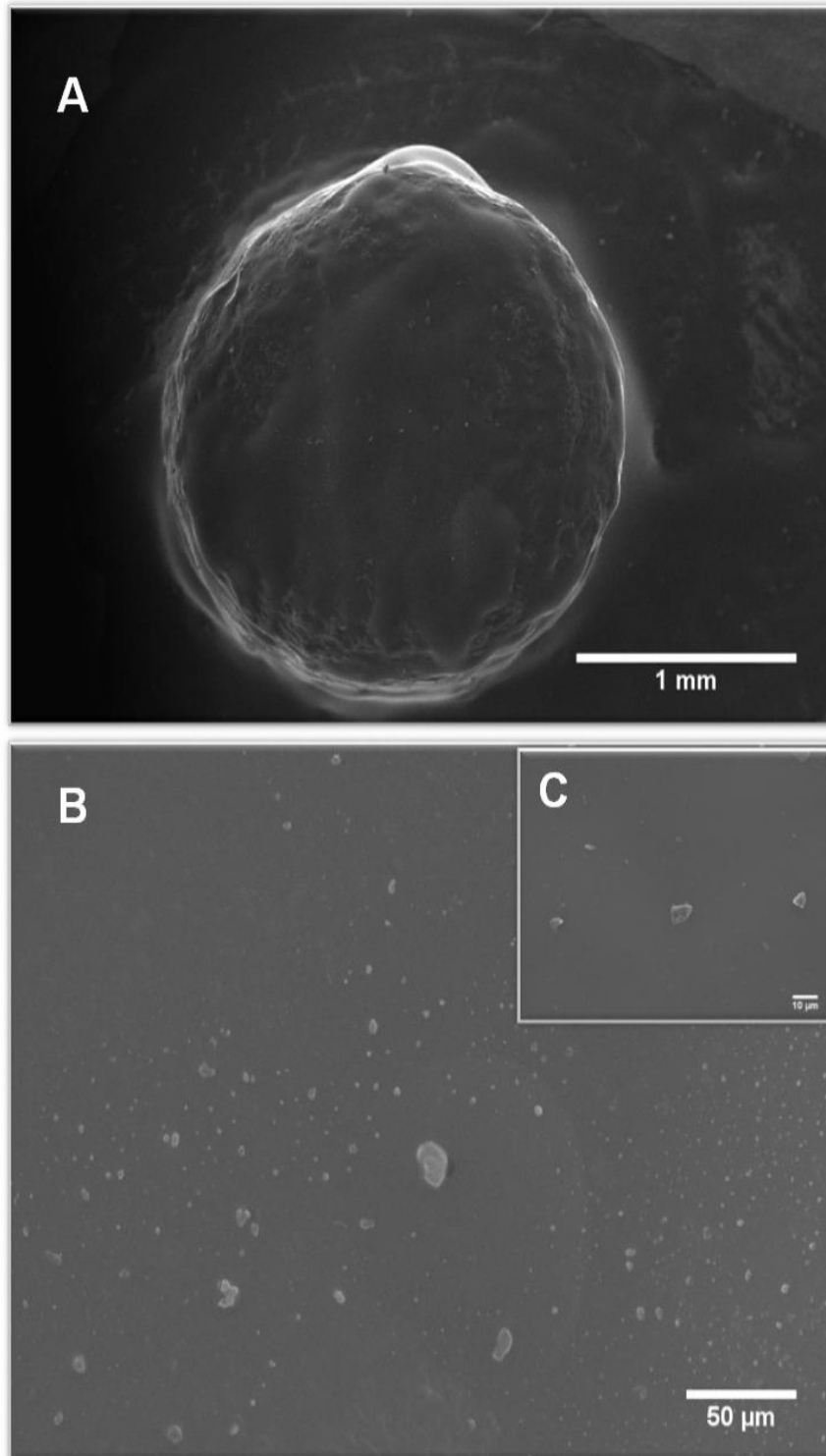

FIGURE 30. SEM micrographs at different magnifications (A) X50; (B) X500 and (C) X1500 for group 2 (glazed zirconia sliders). The surface looks smooth and shiny due to glaze layer.

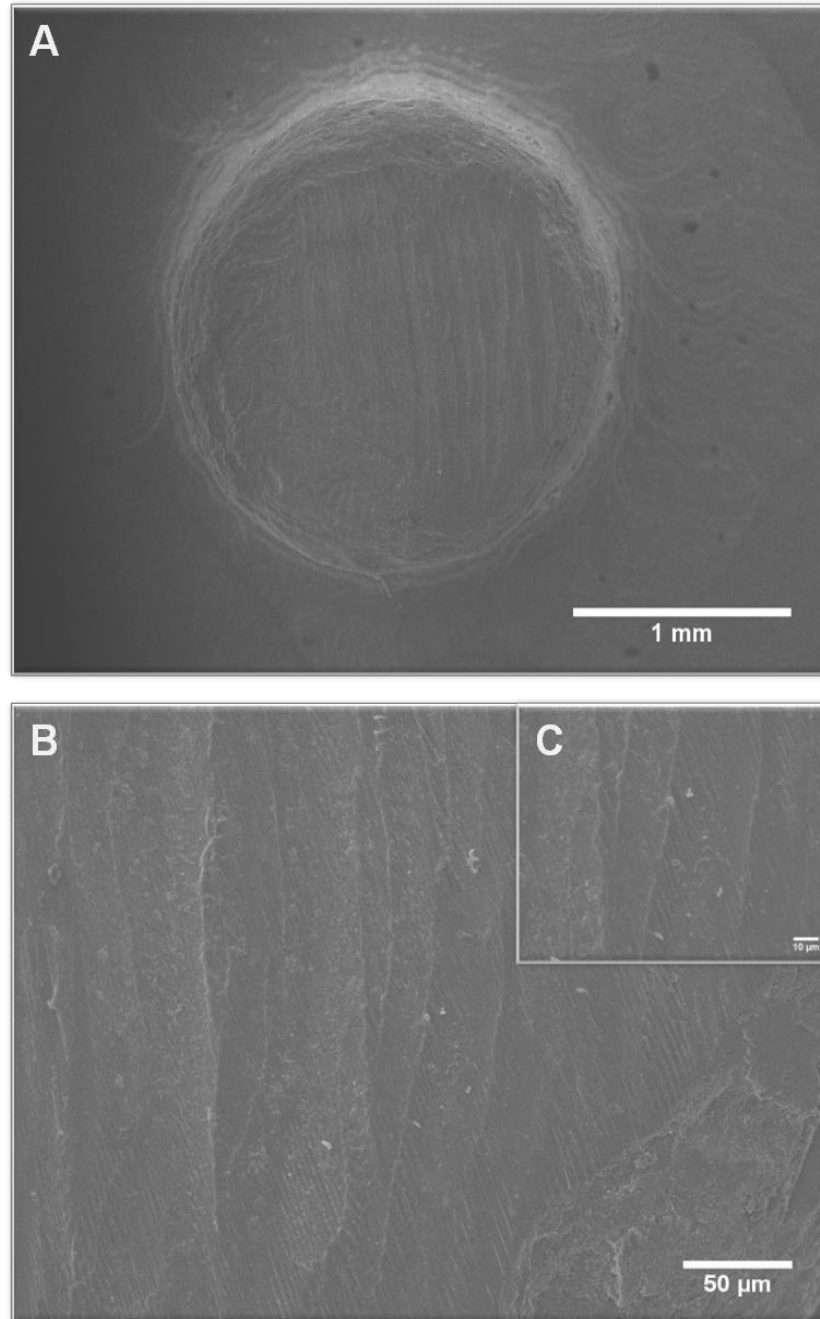

FIGURE 31. SEM micrographs at different magnifications (A) X50; (B) X500 and (C) X1500 for group 3 (bur-finished zirconia sliders). The surface appears rough with parallel irregularities representing the bur strokes.

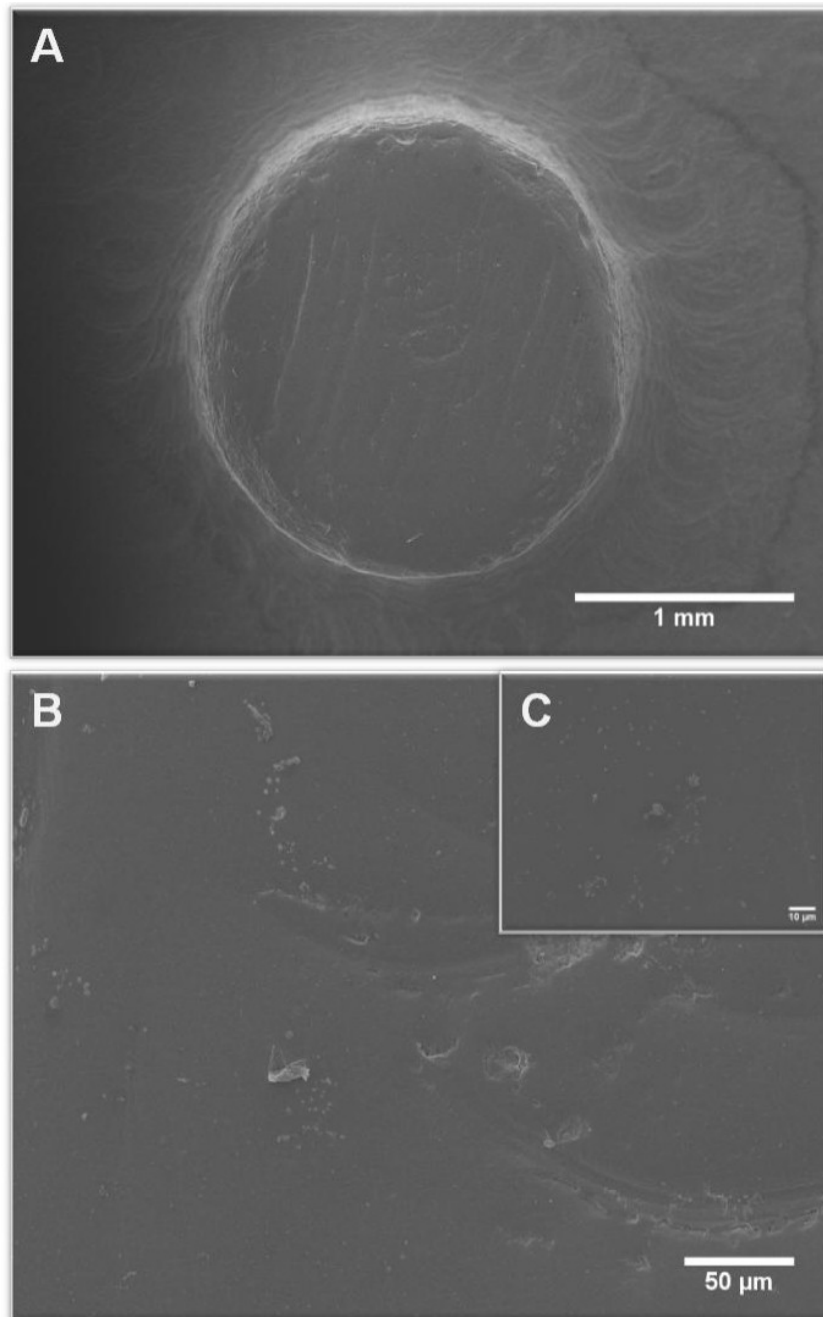

FIGURE 32. SEM micrographs at different magnifications (A) X50; (B) X500 and (C) X1500 for group 4 (bur-finished and polished zirconia sliders). Images revealed a smooth surface with small irregularities.

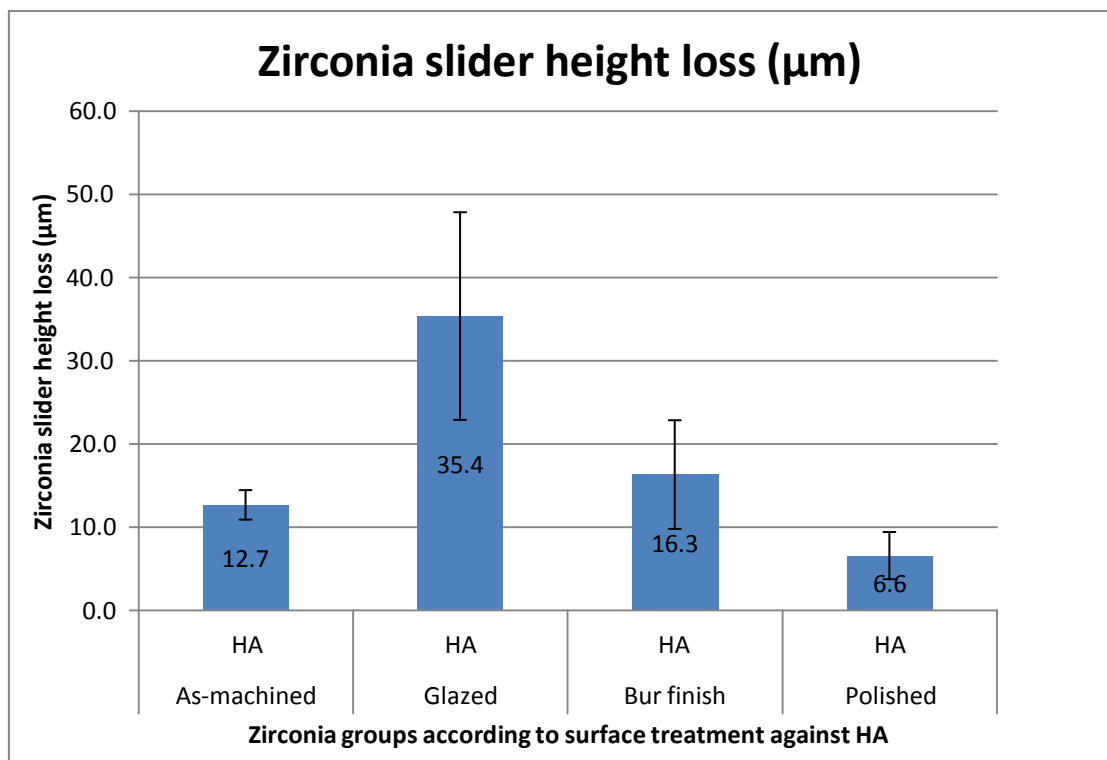

FIGURE 33. Zirconia slider height loss opposing HA antagonist.

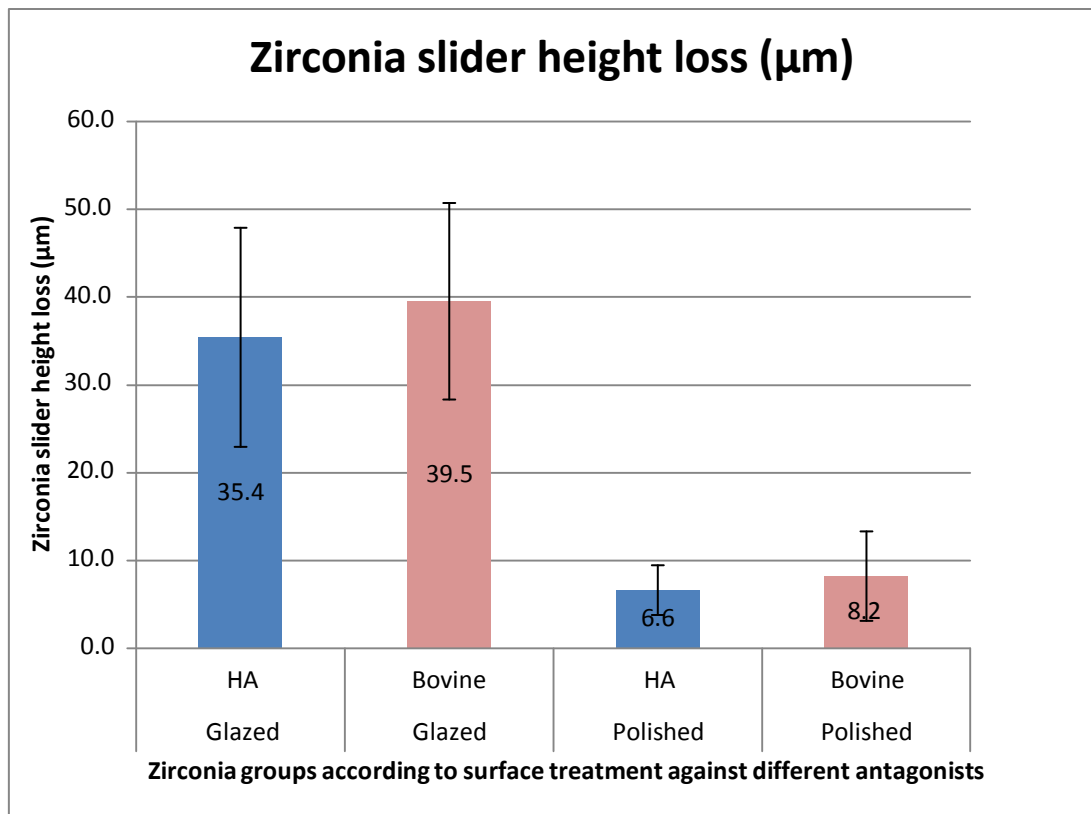

FIGURE 34. Zirconia slider height loss when opposing different antagonists.

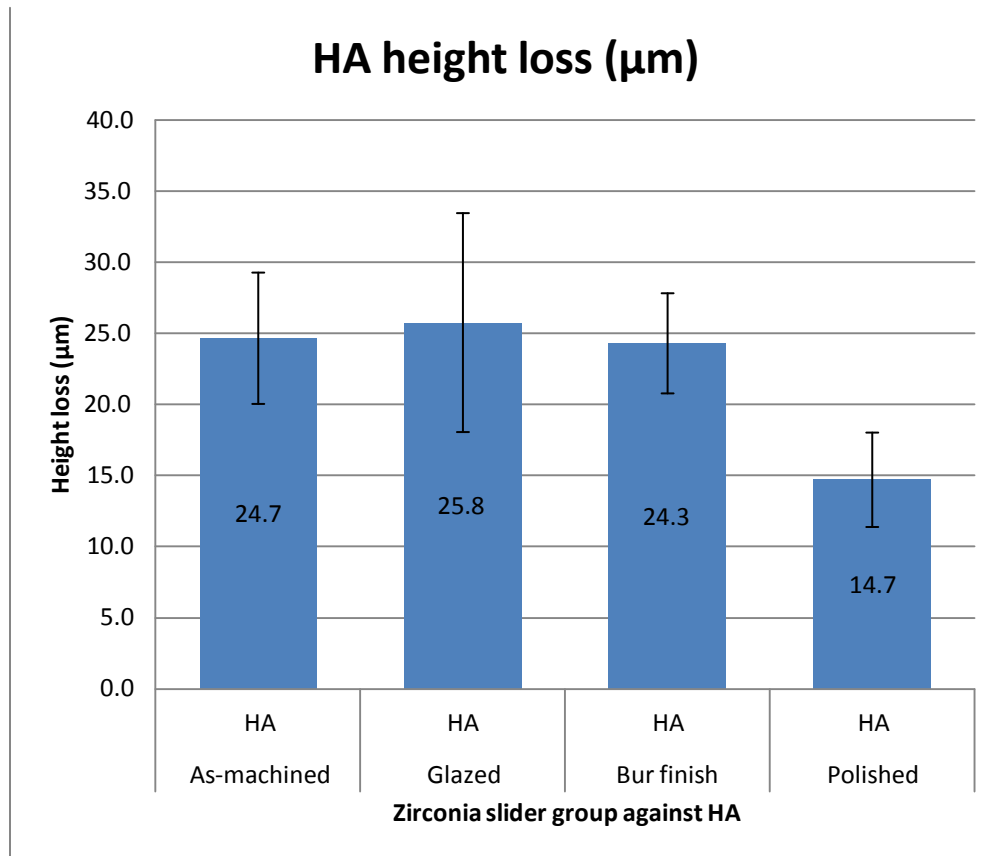

FIGURE 1. HA height loss against different zirconia groups.

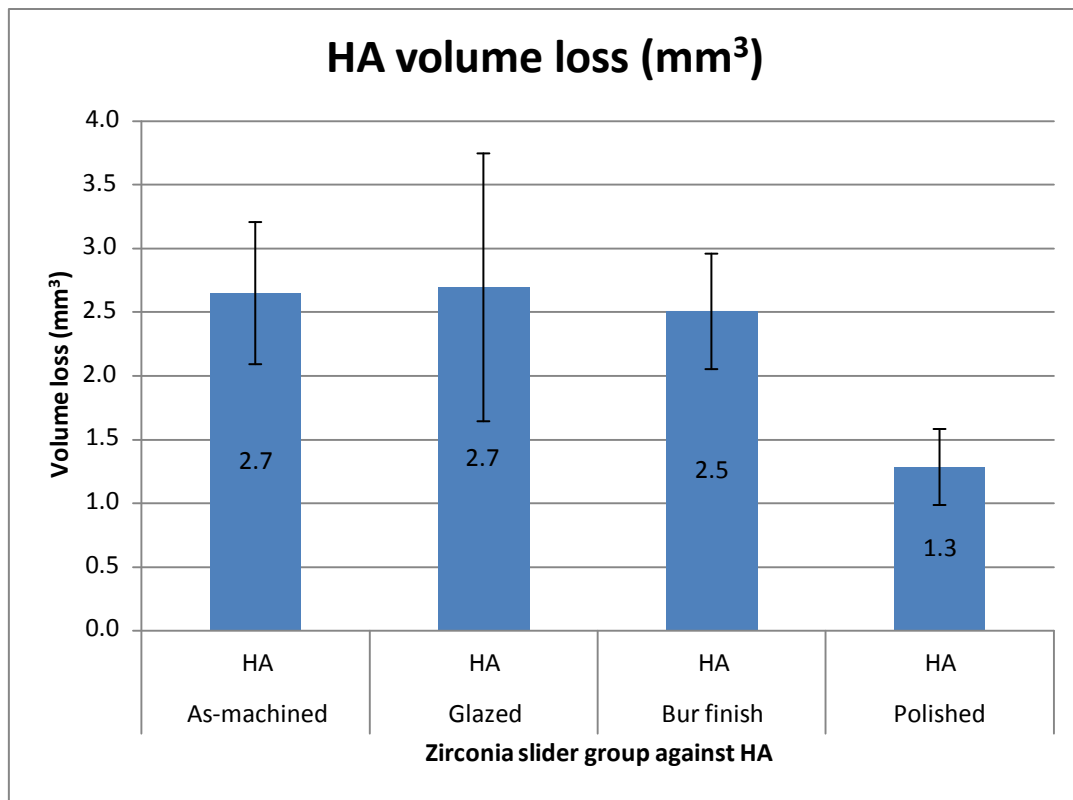

FIGURE 2. HA height loss against different zirconia groups.

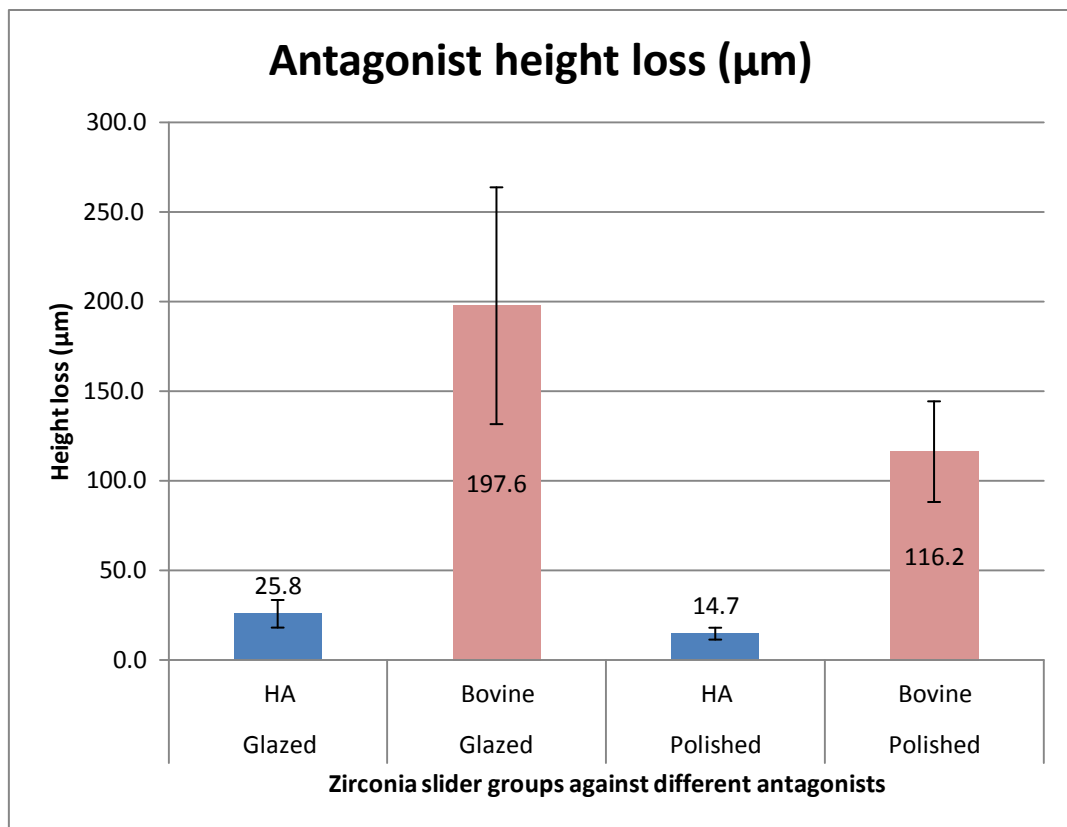

FIGURE 37. Different antagonists (HA, bovine) height loss against glazed/polished zirconia groups.

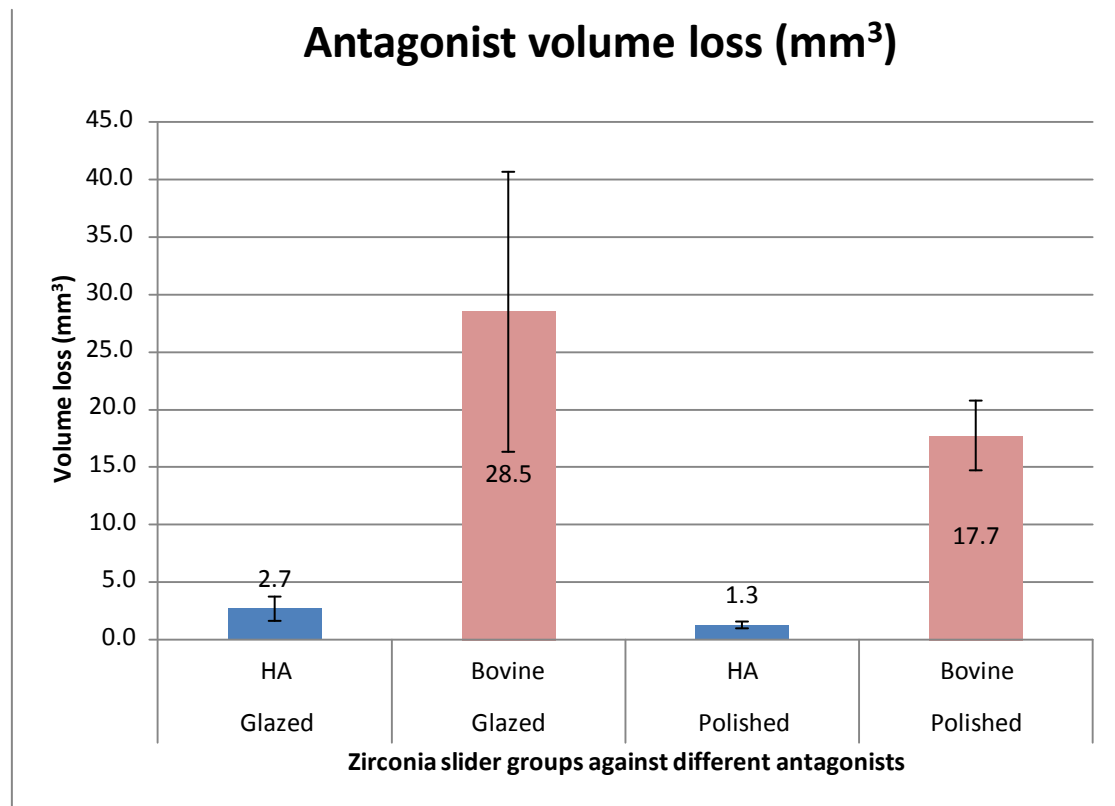

FIGURE 38. Different antagonists (HA, bovine) height loss against glazed/polished zirconia groups.

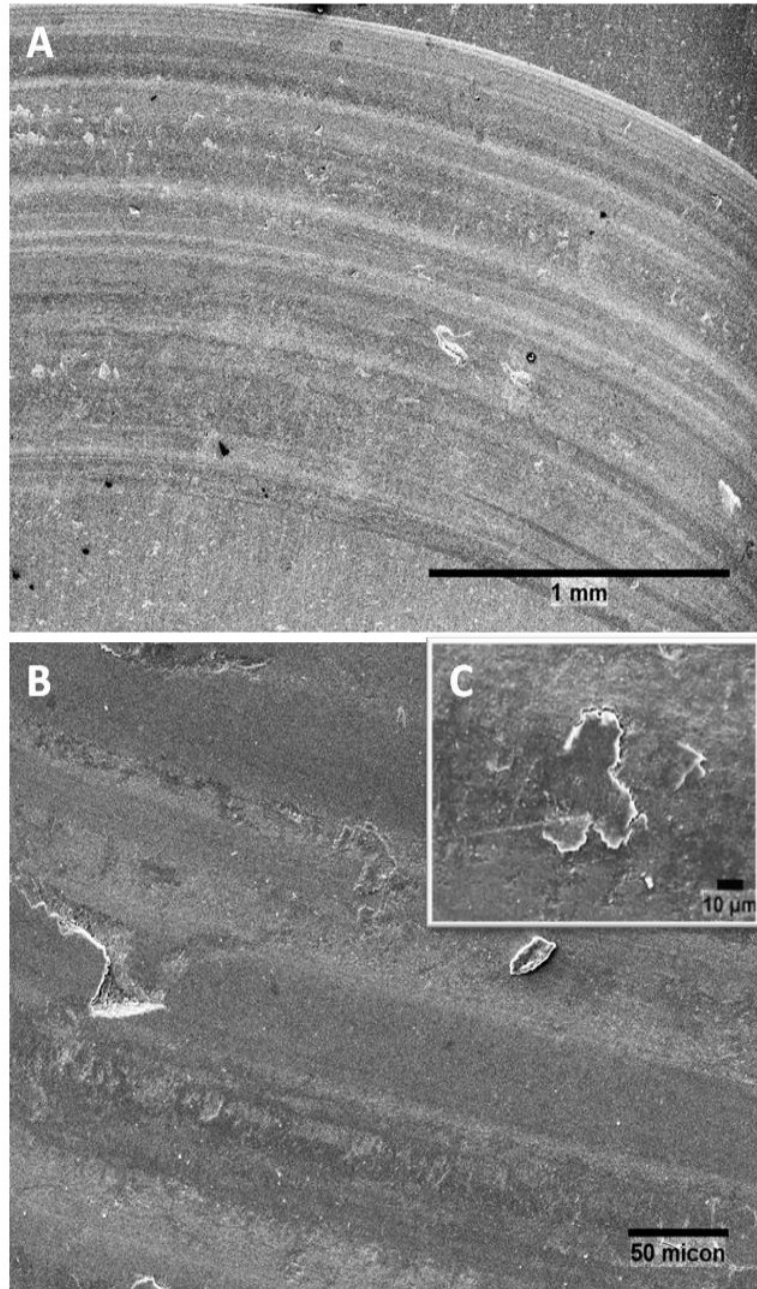

FIGURE39. SEM micrographs at different magnifications (A) X75; (B) X500 and (C) X1500 of the HA surface against group 1 (as-machined zirconia sliders). The surface looks rough with some irregularities and cracks.

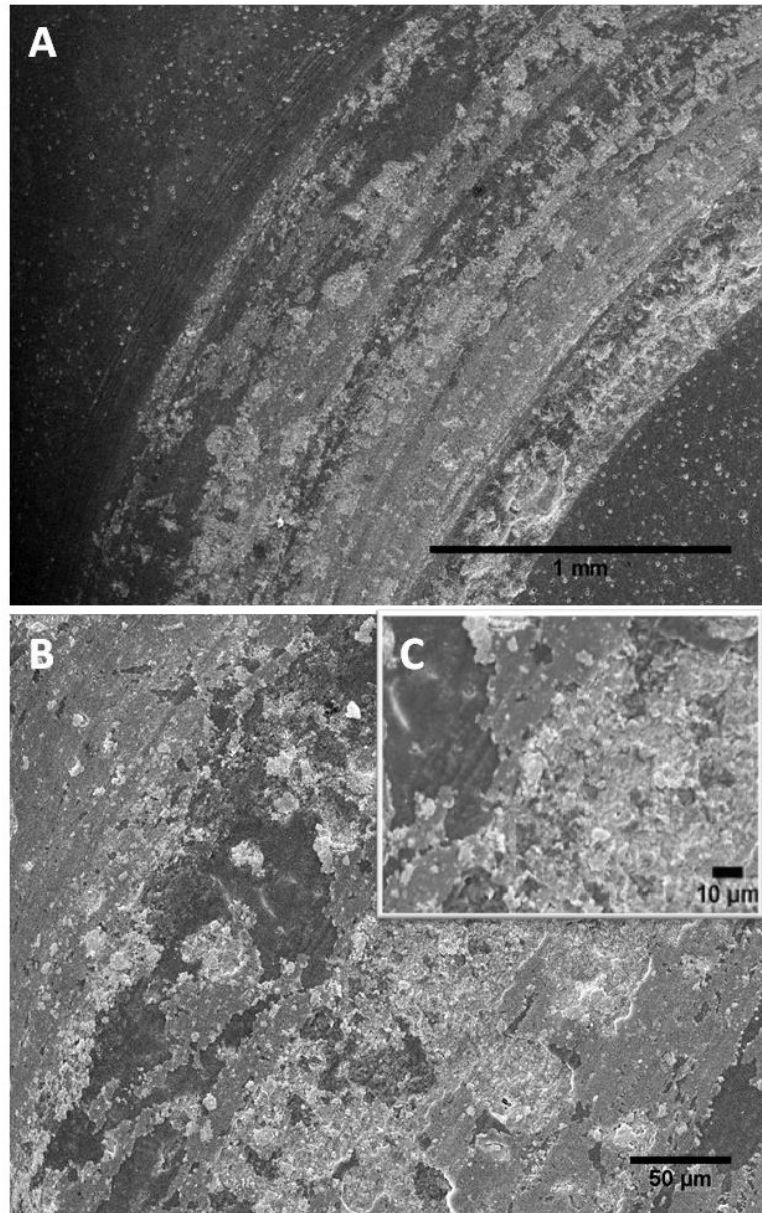

FIGURE 40. SEM micrographs at different magnifications (A) X75; (B) X500, and (C) X1500 of the HA surface against group 2 (glazed zirconia sliders). The surface looks rougher than group 1 with some adherence of glaze material to the HA surface.

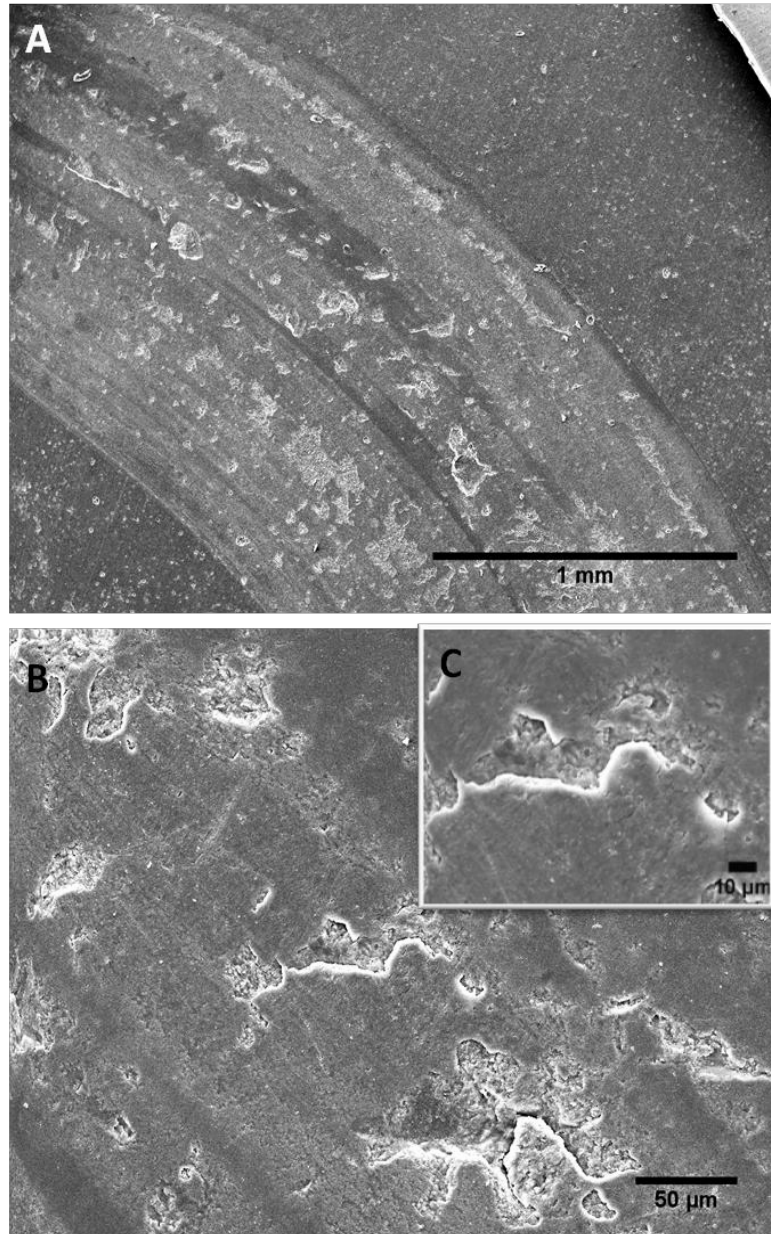

FIGURE 41. SEM micrographs at different magnifications (A) X75; (B) X500, and (C) X1500 of the HA surface against group 3 (bur-finished zirconia sliders). The surface looks rough with some irregularities, cracks, and loss of material.

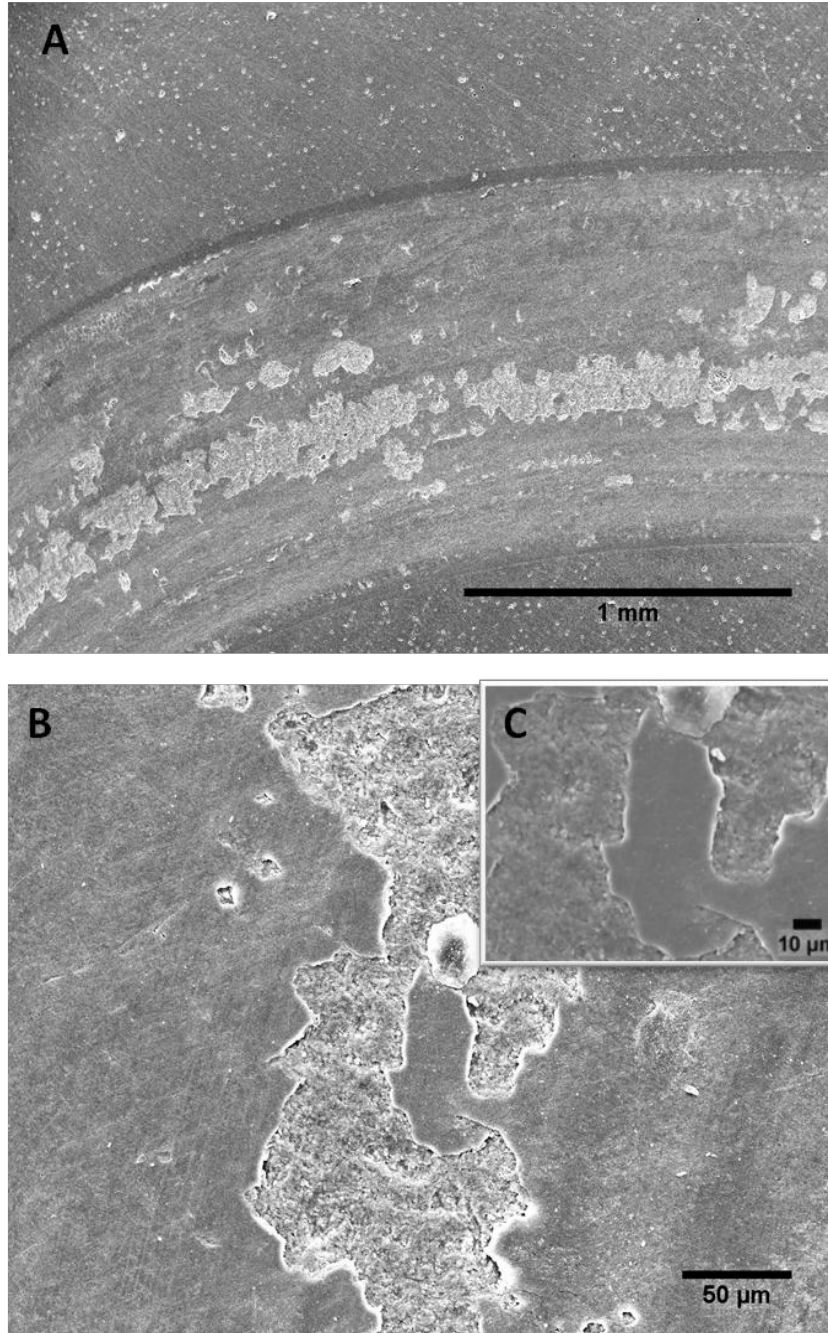

FIGURE 42. SEM micrographs at different magnifications (A) X75; (B) X500, and (C) X1500 of the HA surface against group 4 (bur-finished and polished zirconia sliders). The surface looks smooth with some loss of surface materials.

DISCUSSION

Ceramics are generally considered the most biocompatible, durable, and esthetic dental materials available for restoring human teeth. Currently, there are many dental ceramics available on the market with distinct mechanical and physical properties as well as bonding ability to tooth structures and other substrates. Although dental ceramics have excellent properties that meet requirements of a prosthetic material, it has one major problem: irreversible wear of opposing tooth structure under certain conditions. These conditions are mainly high occlusal forces, which may occur because of parafunctional habits (i.e., clenching, bruxing), and premature occlusal contacts. The most extreme wear damage occurs when a restoration with a rough surface contacts tooth enamel or underlying dentin.⁶

The benefits of glazing and polishing procedures to reduce porcelain abrasiveness have been discussed in the literature. It was stated that the smoother the surfaces, the less wear damage will occur to opposing surfaces. Depending on the dental porcelain, it is claimed that glazing alone may not be able to adequately decrease the surface roughness because the thickness of the glaze layer may be insufficient to fill in grooves and irregularities within the underlying ceramic surface. Thus, it has been recommended that polishing or polishing followed by glazing may give better results.⁶

Our results show that the surface roughness is significantly higher for polished zirconia sliders ($R_a = 0.49$, $R_q = 0.76$) than for glazed zirconia sliders ($R_a = 0.42$, $R_q = 0.63$) ($p = 0.0013$ for R_a , $p = 0.0001$ for R_q). The application of the full-contour zirconia glaze according to the manufacturer recommendations was successful in smoothing the

surface of the zirconia sliders. Qualitative SEM images support this conclusion. Figure 29 through Figure 32 show the SEM images for the different surface treatments at different magnifications. Figure 29 shows the surface of zirconia immediately after the CAD/CAM milling process. The surface shows irregularities introduced during milling with a circular configuration. Figure 30 shows a glazed zirconia slider that looks smooth and shiny, with almost no surface irregularities. Figure 31 shows the bur movement strokes after preparing the group 3 specimens. The circular pattern seen in Figure 29 is now almost a set of parallel lines due to the bur shape and direction. The last image in Figure 32 shows the smoothness accomplished with polishing the surface of group 3 to obtain group 4 specimens. It is apparent that the polished surface is smoother than as-machined and bur-finished groups, but rougher than the glazed group (Figure 30).

The need for polishing before glazing might be true for other types of ceramics as reported by Dalkiz et al.,³¹ but not for full-contour zirconia. The manufacturer for full-contour zirconia glaze materials recommends sand blasting of the restoration surface with alumina no coarser than 50 μm and at pressures not exceeding 50 psi³² before glazing. Yuzugullu et al.³³ studied the effect of different surface treatments, including diamond burs, self-glaze, over-glaze, re-glaze, pearl surface polishing, and diamond twist SCL on porcelain disks. It was concluded that surface treatments significantly affected Ra values ($P < .001$). This is exactly what we found in our study, where the different surface treatments significantly affected the Ra and Rq values ($P = 0.0013$ for Ra, $P = 0.0001$ for Rq).

Our results were similar to the results obtained by Karayazgan et al.,³⁴ who reported that a polished surface of feldspathic porcelain ($Ra = 0.74 \mu\text{m}$) was rougher than

an over-glazed surface ($R_a = 0.58 \mu\text{m}$). Furthermore, SEM comparison of surface roughness showed polished specimens to be rougher than over-glazed specimens.

Similar results were reported by Fuzzi et al.³⁵ where SEM and profilometry for different surface treatments of ceramic showed that the glazed surface was the smoothest, while the use of a 30- μm diamond instrument produced a rougher surface. This is in agreement with our results where the glazed R_a value ($0.42 \mu\text{m}$) was significantly lower than that of the bur-finished group ($0.89 \mu\text{m}$).

Al-Marzok et al.³⁶ also reported that glazed porcelain surfaces are smoother than polished ones. In contrast, Elmaria et al.¹² reported that surface roughness of different ceramics was lower for polished surfaces versus glazed surfaces. The explanation for this might be related to sample fabrication, where they polish the ceramic surfaces after glazing. Al-Hiyasat et al.³⁷ reported insignificant differences in the wear of enamel opposing glazed and polished ceramic groups, but the wear produced by unglazed/unpolished groups was significantly higher ($P < .05$).

Our results are the first comparing the effects of different surface treatments on the surface roughness of full-contour zirconia. The groups were chosen based on the adjustments commonly made to ceramic restorations in clinical situations. The first group was the control group; the second (glazed group) represents no need for occlusal corrections, and the crown is cemented without modification. The third group represents the occlusal corrections that are typical in most clinical cases, which might be left unpolished. The last group represents current recommendations. Polishing procedures are completed after occlusal corrections in order to re-establish a smooth, glazed-like zirconia surface using intraoral polishing instruments or kits.⁷

As mentioned previously, Ghazal et al.⁴ showed that the antagonistic surface roughness has a significant effect on the wear of human enamel, and that the correlation between the volume loss and antagonistic surface roughness was significant. This correlation was also reported by Elmaria et al.¹² In our study, this correlation was present in group 1 (Ra = 0.84 μm), group 3 (Ra = 0.89 μm) and group 4 (Ra = 0.49 μm). The surface roughness in these was correlated with the amount of wear observed in HA (24.7 μm , 2.7 mm^3 ./24.3 μm , 2.5 mm^3 ./14.7 μm , 1.3 mm^3 respectively.). The smooth-polished zirconia surface produced the least amount of wear in the opposing surface.

On the other hand, the glazed group 2 showed a different trend. Although the surface roughness measurements revealed the smoothest surface (Ra = 0.42, Rq = 0.63), the amount of wear observed in HA was almost similar to groups 1 and 3 (25.8 μm , 2.7 mm^3). These findings corroborate a study by Heintze et al.,⁷ where it was reported that flat glazed surfaces show more antagonist wear than polished surfaces. An explanation of this relies on the variable that we applied the glaze material on the milled surface directly; this surface had irregularities and surface roughness similar to group 1 (as-machined zirconia sliders). During the wear testing, the HA antagonist wore away the glaze layer exposing the underlying rough surface. Therefore, one could speculate that the glazed zirconia sliders will not act as a glazed smooth surface once the glaze is worn away, but will act as group 1 (as-machined). For polished zirconia surfaces, because of the lower coefficient of friction, less antagonist wear was seen. This is applicable to CAD/CAM restorations where mechanical milling of the restoration produces rough surfaces over which glaze materials are applied.⁷

This explanation is also supported by the results obtained for vertical height loss of the zirconia sliders. Glazed zirconia sliders had significantly more slider height loss (35.39 μm) than as-machined (12.70 μm) ($p < 0.0001$), bur finished (16.34 μm) ($p = 0.0005$), and polished zirconia sliders (6.61 μm) ($p < 0.0001$). The higher vertical loss of group 2 might represent the thickness of the glaze layer accounting for the 16.4 μm difference in slider height of the as-machined and glazed groups when measured prior to wear testing.

The same results were seen when changing the antagonist material (i.e., bovine instead of HA specimens). Polished zirconia sliders had significantly less antagonist height loss and volume loss (116.2 μm , and 17.7 mm^3) compared with glazed zirconia sliders (197.6 μm , and 28.5 mm^3) ($p = 0.0001$, $p = 0.0018$, respectively). Similarly, the same explanation may perhaps be applied here, where polished zirconia sliders had significantly less slider height loss (8.2 μm) than glazed zirconia sliders (39.5 μm) ($p = 0.0001$) suggesting the wearing away of the glaze layer and exposure of the rougher underlying surface. Olivera et al.³⁸ and Elmaria et al.¹² have also reported that polished ceramics produced less enamel wear than glazed ceramics.

The values of HA height loss and volume loss against different zirconia groups (14.7-25.8 μm and 1.3-2.7 mm^3) are close to those reported by Ghazal et al.¹⁹ The vertical height loss of tooth enamel ranged from 19 μm to 35 μm against zirconia balls. However, the differences in the wear machine and parameters make it difficult to make an accurate comparison between our study and their results.

Figure 37 through Figure 40 show the wear track observed on HA surfaces when facing the four different zirconia-surface treatment groups. Figure 37 shows the track

outline (HA against G1-as machined zirconia group), which appears slightly rough compared with the smoother original polished HA surface. Indeed, small cracks are seen at higher magnification. Figure 38 shows the track outline (HA against G2-glazed zirconia group), which appears rougher compared with the original polished HA surface. The image suggests that the glaze layer has been removed and that it adheres to the HA surface, a phenomenon that suggests adhesive and fatigue wear processes. During these, the adhesion changed the wear process from two-body to three-body and led to an increased amount of wear in HA opposing glazed zirconia. Figure 39 shows the track outline (HA against G3-bur-finished zirconia group), which appears as in G1, but much rougher. Cracks and surface loss of HA are suggestive of abrasion and surface fatigue. Finally, Figure 40 shows the track outline (HA against G4: bur-finished and polished zirconia group), which appears similar to G3, but the surface looks smoother with less surface loss and indicates a surface fatigue wear process.

When comparing the wear behavior of bovine enamel and HA against G2-Glazed and G4-bur-finished and polished zirconia, antagonist height loss and antagonist volume loss were significantly higher for the bovine than for the HA antagonists ($197.6 \mu\text{m}/116.2 \mu\text{m}$, and $28.5 \text{ mm}^3/17.7 \text{ mm}^3$ for bovine against glazed/polished zirconia sliders respectively) ($p < 0.0001$). This give us a 7.7-times to 7.9-times increase in bovine height loss as compared with HA, and a 10.6-times to 13.6-times increase in volume loss of bovine enamel as compared with HA.

These results are similar to those of Mehl et al.,²⁶ who reported that the wear behavior of steatite ceramic balls antagonistic to bovine enamel showed a volume loss nearly three times higher than steatite ceramic balls antagonistic to human enamel.

Although these findings were not statistically different, they suggested that bovine enamel is not able to substitute for human enamel *in-vitro* wear studies.

An explanation for the great differences of wear behavior between the two antagonists may also be related to the fabrication technique. The sample surface area used in the present study was about 64 mm². This area might represent different enamel properties and thicknesses. It is known that enamel prisms and orientation differ according to their position in the tooth crown; therefore, varied results might be found. Another reason is that polishing the bovine enamel to a flat surface might have removed a larger amount of harder enamel tooth structure and exposed the softer enamel underneath. This may also account for the significant standard deviation seen for bovine enamel compared with HA (Figure 35 and Figure 36). When comparing the zirconia height loss between G2-glazed/HA and G2-glazed-bovine, no significant differences were found (35.4 μm, 39.5 μm). The same trend was noticed when comparing the zirconia height loss between G4-polished/HA and G4-polished-bovine (6.6 μm, 8.2 μm, respectively). The larger differences in height loss and volume loss between HA and bovine might suggest a lower zirconia height loss when facing softer layers of bovine enamel, but this was not the case in our results, where both HA and bovine had the same amount of zirconia height loss. An explanation of that could be related to the insufficient water lubrication of the samples once the slider is moving deeper inside the bovine samples. A three-body wear process due to accumulation of debris might lead to an increased zirconia height loss when opposing the underlying softer layers of bovine enamel.

SUMMARY AND CONCLUSION

From these results, it can be concluded that:

1. Surface treatments played a significant role on full-contour zirconia surface roughness.
2. Although glazing reduced surface roughness, it did not alter the wear behavior of zirconia when compared with other unglazed groups.
3. The results suggested that polishing the zirconia surface might be the best treatment to reduce surface roughness and antagonist wear of HA and bovine enamel.

REFERENCES

1. Albashaireh ZS, Ghazal M, Kern M. Two-body wear of different ceramic materials opposed to zirconia ceramic. *J Prosthet Dent* 2010;104(2):105-13.
2. Lazar DR, Bottino MC, Ozcan M, et al. Y-TZP ceramic processing from coprecipitated powders: a comparative study with three commercial dental ceramics. *Dent Mater* 2008;24(12):1676-85.
3. Conrad HJ, Seong WJ, Pesun IJ. Current ceramic materials and systems with clinical recommendations: a systematic review. *J Prosthet Dent* 2007;98(5):389-404.
4. Ghazal M, Kern M. The influence of antagonistic surface roughness on the wear of human enamel and nanofilled composite resin artificial teeth. *J Prosthet Dent* 2009;101(5):342-9.
5. Ramp MH, Ramp LC, Suzuki S. Vertical height loss: an investigation of four restorative materials opposing enamel. *J Prosthodont* 1999;8(4):252-7.
6. Anusavice KJ. *Phillips' science of dental materials*. 11th ed. St. Louis: Saunders-Elsevier Science, 2003.
7. Heintze SD, Cavalleri A, Forjanic M, Zellweger G, Rousson V. Wear of ceramic and antagonist -- a systematic evaluation of influencing factors in vitro. *Dent Mater* 2008;24(4):433-49.
8. Palmer DS, Barco MT, Pelleu GB, Jr., McKinney JE. Wear of human enamel against a commercial castable ceramic restorative material. *J Prosthet Dent* 1991;65(2):192-5.
9. Li Y, Swartz ML, Phillips RW, Moore BK, Roberts TA. Effect of filler content and size on properties of composites. *J Dent Res* 1985;64(12):1396-401.
10. Jain V, Platt JA, Moore BK, Borges GA. In vitro wear of new indirect resin composites. *Oper Dent* 2009;34(4):423-8.
11. Shortall AC, Hu XQ, Marquis PM. Potential countersample materials for in vitro simulation wear testing. *Dent Mater* 2002;18(3):246-54.
12. Elmaria A, Goldstein G, Vijayaraghavan T, Legeros RZ, Hittelman EL. An evaluation of wear when enamel is opposed by various ceramic materials and gold. *J Prosthet Dent* 2006;96(5):345-53.

13. Imfeld T. Dental erosion. Definition, classification and links (Pt 2). *Eur J Oral Sci* 1996;104(2):151-5.
14. ten Cate JM, Imfeld T. Dental erosion, summary (Pt 2). *Eur J Oral Sci* 1996;104(2) :241-4.
15. Lambrechts P, Debels E, Van Landuyt K, Peumans M, Van Meerbeek B. How to simulate wear? Overview of existing methods. *Dent Mater* 2006;22(8):693-701.
16. Kadokawa A, Suzuki S, Tanaka T. Wear evaluation of porcelain opposing gold, composite resin, and enamel. *J Prosthet Dent* 2006;96(4):258-65.
17. Lambrechts P, Braem M, Vuylsteke-Wauters M, Vanherle G. Quantitative in vivo wear of human enamel. *J Dent Res* 1989;68(12):1752-4.
18. Heintze SD. How to qualify and validate wear simulation devices and methods. *Dent Mater* 2006;22(8):712-34.
19. Ghazal M, Kern M. Wear of human enamel and nano-filled composite resin denture teeth under different loading forces. *J Oral Rehabil* 2009;36(1):58-64.
20. Seghi RR, Rosenstiel SF, Bauer P. Abrasion of human enamel by different dental ceramics in vitro. *J Dent Res* 1991;70(3):221-5.
21. Ghazal M, Albashaireh ZS, Kern M. Wear resistance of nanofilled composite resin and feldspathic ceramic artificial teeth. *J Prosthet Dent* 2008;100(6):441-8.
22. Preis V, Behr M, Kolbeck C, Hahnel S, Handel G, Rosentritt M. Wear performance of substructure ceramics and veneering porcelains. *Dent Mater* 2011; Aug;27(8):796-804.
23. Sarikaya I, Guler AU. Effects of different polishing techniques on the surface roughness of dental porcelains. *J Appl Oral Sci* 2010;18(1):10-6.
24. Rosentritt M, Preis V, Behr M, Hahnel S, Handel G, Kolbeck C. Two-body wear of dental porcelain and substructure oxide ceramics. *Clin Oral Investig* 2011; Jul 8. [E-pub ahead of print]
25. Attin T, Wegehaupt F, Gries D, Wiegand A. The potential of deciduous and permanent bovine enamel as substitute for deciduous and permanent human enamel: Erosion-abrasion experiments. *J Dent* 2007;35(10):773-7.
26. Mehl C, Scheibner S, Ludwig K, Kern M. Wear of composite resin veneering materials and enamel in a chewing simulator. *Dent Mater* 2007;23(11):1382-9.

27. Messias DC, Turssi CP, Hara AT, Serra MC. Sodium bicarbonate solution as an anti-erosive agent against simulated endogenous erosion. *Eur J Oral Sci* 2010;118(4):385-8.
28. Ltd SIP. Scantron Proscan 2000 software manual. Roughness measurements: a guide. Taunton, England; 2004.
29. Jain VV. Evaluation of second generation indirect composite resins. [Thesis]. Indianapolis: Indiana University School of Dentistry, 2008.
30. Lahiri D, Benaduce AP, Rouzaud F, et al. Wear behavior and in vitro cytotoxicity of wear debris generated from hydroxyapatite-carbon nanotube composite coating. *J Biomed Mater Res A* 2011;96(1):1-12.
31. Dalkiz M, Sipahi C, Beydemir B. Effects of six surface treatment methods on the surface roughness of a low-fusing and an ultra low-fusing feldspathic ceramic material. *J Prosthodont* 2009;18(3):217-22.
32. Diadem pt. instructions for use stain and glaze, Diazir full contour zirconia. <http://www.diademprecision.com/images/pdfs/diazir-stain-glaze-IFU.pdf>; 2011.
33. Yuzugullu B, Celik C, Erkut S, Ozcelik TB. The effects of extraoral porcelain polishing sequences on surface roughness and color of feldspathic porcelain. *Int J Prosthodont* 2009;22(5):472-5.
34. Karayazgan B, Atay A, Saracli MA, Gunay Y. Evaluation of *Candida albicans* formation on feldspathic porcelain subjected to four surface treatment methods. *Dent Mater J* 2010;29(2):147-53.
35. Fuzzi M, Zaccheroni Z, Vallania G. Scanning electron microscopy and profilometer evaluation of glazed and polished dental porcelain. *Int J Prosthodont* 1996;9(5):452-8.
36. Al-Marzok MI, Al-Azzawi HJ. The effect of the surface roughness of porcelain on the adhesion of oral *Streptococcus mutans*. *J Contemp Dent Pract* 2009;10(6):E017-24.
37. al-Hiyasat AS, Saunders WP, Sharkey SW, Smith GM, Gilmour WH. Investigation of human enamel wear against four dental ceramics and gold. *J Dent* 1998;26(5-6):487-95.
38. Olivera AB, Matson E, Marques MM. The effect of glazed and polished ceramics on human enamel wear. *Int J Prosthodont* 2006;19(6):547-8.

ABSTRACT

THE EFFECT OF FULL-CONTOUR Y-TZP CERAMIC SURFACE ROUGHNESS ON
THE WEAR OF BOVINE ENAMEL AND SYNTHETIC HYDROXYAPATITE:
AN *IN-VITRO* STUDY

by

Alaa Hussein Aref Sabrah

Indiana University School of Dentistry
Indianapolis, Indiana

Full-contour yttrium-stabilized tetragonal zirconia polycrystal (Y-TZP) restorations have been advocated recently in clinical situations where occlusal/palatal space is limited, or to withstand parafunctional activities. The objectives of this *in-vitro* study were to investigate the effects of different polishing techniques on the surface roughness of Y-TZP (Arden Dental, Inc.) and to investigate the effects of different polishing techniques on the wear behavior of synthetic hydroxyapatite (HA) and bovine enamel.

An *in-vitro* study was conducted by fabrication of 48 Y-TZP sliders (diameter = 2 mm × 1.5 mm in height) using CAD/CAM technique; then the samples were embedded in acrylic resin using brass holders. Samples were then randomly allocated into four groups according to the finishing/polishing procedure: G1-as-machined (n = 8), G2-

glazed (n = 16), G3-diamond bur-finishing (Brasseler, USA) (n = 8) and G4-G3+OptraFine polishing kit (Ivoclar-Vivadent) (n = 16). Thirty-two sintered HA disks (diameter = 11 mm × 2.9 mm in height) and 16 bovine enamel samples with a minimum surface area of 64 mm² were mounted in brass holders. Baseline surface roughness (Ra and Rq, in μm) were recorded using a non-contact profilometer (Proscan 2000) for all the samples. A two-body pin-on-disk wear test was performed for 25,000 cycles at 1.2 Hz in which the four zirconia groups were tested against HA, and only G2-glazed and G4-G3+OptraFine polishing kit (Ivoclar-Vivadent) were tested against bovine enamel. Vertical substance loss (μm) and volume loss (mm³) of HA were measured (Proscan). Zirconia height loss was measured using a digital micrometer. One-way ANOVA was used for statistical analysis.

The results indicated that surface roughness measurements showed significant differences among the surface treatments with G1 (Ra = 0.84, Rq = 1.13 μm) and G3 (Ra = 0.89, Rq = 1.2 μm) being the roughest, and G2 (Ra = 0.42, Rq = 0.63 μm) the smoothest. The glazed group showed the highest vertical loss (35.39 μm) suggesting wear of the glaze layer, while the polished group showed the least vertical loss (6.61 μm). HA antagonist volume loss and vertical height loss for groups (G1, G2 and G3) were similar, while polished group (1.3 mm³, 14.7 μm) showed significant lower (p = 0.0001) values. Antagonist height loss and antagonist volume loss were significantly higher for bovine antagonist than for HA antagonist (197.6 μm/116.2 μm, and 28.5 mm³/17.7 mm³ for bovine against glazed/polished zirconia sliders, respectively) (p < 0.0001).

From the results it can be concluded that glazed zirconia provided an initially smooth surface, but a significant increased antagonist wear compared with the polished surface was seen.

Bovine enamel showed higher wear compared with HA, which suggested that more studies should be performed to validate the use of bovine enamel as a substitute for human enamel in wear studies.

CURRICULUM VITAE

Alaá Hussein Aref Sabrah

December 1984	Born in Sahab, Jordan
July 2002	High School Diploma Sahab High School for Girls Sahab, Jordan
July 2007	Bachelor of Dental Science Degree (BDS), Faculty of Dentistry University of Jordan Amman, Jordan
September 2007	Internship University of Jordan Hospital University of Jordan Amman, Jordan
February 2008	Demonstrator (Teacher and Research Assistant) Operative Dentistry Division Conservative Department Faculty of Dentistry University of Jordan Amman, Jordan
May 2009	Accepted by Graduate Operative Dentistry program for the MSD Indiana University School of Dentistry, Indianapolis, IN
August 2011	Accepted by doctoral program in Dental Science Indiana University School of Dentistry Indianapolis, IN

Program Organizations

The Academy of Operative Dentistry
AADR/IADR
Jordan Dental Association