

2015

Failure at Fidenae: Visualization and Analysis of the Largest Structural Disaster in the Roman World

Rebecca Napolitano
Connecticut College, rnapolitano@gmail.com

Follow this and additional works at: <http://digitalcommons.conncoll.edu/physicshp>

 Part of the [Architectural Engineering Commons](#), and the [Classical Archaeology and Art History Commons](#)

Recommended Citation

Napolitano, Rebecca, "Failure at Fidenae: Visualization and Analysis of the Largest Structural Disaster in the Roman World" (2015). *Physics, Astronomy and Geophysics Honors Papers*. Paper 7.
<http://digitalcommons.conncoll.edu/physicshp/7>

This Honors Paper is brought to you for free and open access by the Physics, Astronomy and Geophysics Department at Digital Commons @ Connecticut College. It has been accepted for inclusion in Physics, Astronomy and Geophysics Honors Papers by an authorized administrator of Digital Commons @ Connecticut College. For more information, please contact bpancier@conncoll.edu.

The views expressed in this paper are solely those of the author.

FAILURE AT FIDENAE: VISUALIZATION AND ANALYSIS OF THE LARGEST
STRUCTURAL DISASTER IN THE ROMAN WORLD

by

Rebecca Napolitano

A thesis submitted in partial fulfilment of the requirements for the degree of

Bachelor of Arts

in Physics

Connecticut College

2015

Thesis Committee:

Michael N. Monce, Ph.D.

Department of Physics, Astronomy, and Geophysics, Connecticut College

David B. George, Ph. D.

Department of Classics, St. Anselm College

Elizabeth Nakagawa, M.S., M.B.A., P.E.

Department of Engineering, United States Coast Guard Academy

To the Connecticut College Physics Department

Whose theories for the collapse ranged from a micro black hole to abduction by alien space craft, and without whose help this would not have been possible (especially Professor Monce.) Thanks for giving me guidance, B's, and a family.

Much love and gratitude.

TABLE OF CONTENTS

List of Figures.....	4
List of Tables.....	6
Abstract.....	7
Chapter 1: Background Information.....	8
Primary Literary Sources.....	8
Capacity and Scale.....	10
Foundations and Joints.....	13
Theories Concerning the Collapse.....	15
Chapter 2: “Did that many people <i>really</i> die?”	18
Most Probable Typology.....	18
Most Probable Seating Capacity.....	20
Archaeological Evidence.....	20
Literary Evidence.....	27
Two-Dimensional Layout.....	34
Most Probable Height.....	35
Chapter 3: “What did this look like?”	39
Framework and Supports.....	39
Three Dimensional Design and Model.....	51
Chapter 4: “What did Atilius do so wrong?”	56
Topographical Overview and Soil Profile of Fidenae.....	56
Archaeological Comments on Amphitheater at Fidenae.....	59
Analysis of Foundations.....	59
Joint Stress Analysis.....	71
Chapter 5: Concluding Thoughts.....	86

References.....90
Appendix A: Needed and Allowable Loads for Vertical Supports.....93
Appendix B: Weight of Materials Calculations.....96
Appendix C: Pile Capacity.....99

LIST OF FIGURES

Figure 2.1 Graph of Seating Capacity versus Overall Area.....	20
Figure 2.2 Graph of Overall Area versus Seating Capacity.....	22
Figure 2.3 Graph of Overall Major Axis versus Seating Capacity.....	23
Figure 2.4 Graph of Overall Minor Axis versus Seating Capacity.....	24
Figure 2.5 Graph of Arena Area versus Seating Capacity.....	25
Figure 2.6 Graph of Arena Major Axis versus Seating Capacity	25
Figure 2.7 Graph of Arena Minor Axis versus Seating Capacity.....	25
Figure 2.8 Graph of <i>Cavea</i> Width versus Seating Capacity.....	26
Figure 2.9 Ellipse Nomenclature.....	28
Figure 2.10 Depiction of Wooden Amphitheater on Trajan’s Column.....	30
Figure 2.11 Collapse Theory 1.....	31
Figure 2.12 Two Dimensional Layout.....	34
Figure 2.13 Top View Amphitheater at Verona.....	35
Figure 2.14 Cross-Sectional View Amphitheater at Verona.....	36
Figure 2.15 <i>Cavea</i> Cross-Section.....	37
Figure 3.1 Amphitheatrical Nomenclature.....	40
Figure 3.2 Deflection of Simply Supported Beam Due to Point Load.....	42
Figure 3.3 Deflection of Simply Supported Beam Due to Distributed Load	43
Figure 3.4 Density of <i>Abies Alba</i> in Europe.....	45
Figure 3.5 Cross-Sectional View of Segment of Amphitheater at Fidenae.....	49
Figure 3.6 Cross-Sectional View of the Amphitheater at Fidenae.....	50
Figure 3.7 Wooden Amphitheater on Trajan’s Column.....	51
Figure 3.8 Zoomed-View of Triangular Supports on Wooden Amphitheater.....	51
Figure 3.9 View of Edifice of Amphitheater.....	51

Figure 3.10 Trajan’s Bridge on Trajan’s Column.....	52
Figure 3.11 Zoomed-View of Triangular Supports on Trajan’s Bridge.....	52
Figure 3.12 Details of Tier 1 Edifice and Triangular Supports.....	52
Figure 3.13 Top View of Amphitheater at Fidenae.....	53
Figure 3.14 Aerial View of Amphitheater at Fidenae.....	54
Figure 4.1 Soil Map of Italy.....	57
Figure 4.2 Soil Textural Triangle.....	58
Figure 4.3 FBD Outermost Pile without Load from People.....	62
Figure 4.4 Graph of Distance versus Supported Load/Load Width (Materials).....	63
Figure 4.5 Lateral Supports.....	67
Figure 4.6 FBD Outermost Pile with Load from People.....	69
Figure 4.7 Graph of Distance versus Supported Load/Load Width (Total Load).....	70
Figure 4.8 Joint Nomenclature.....	72
Figure 4.9 Joint 1.....	72
Figure 4.10 FBD Joints 1,4-7.....	73
Figure 4.11 Components of Weight.....	74
Figure 4.12 Joint 1 Stress Graphical Solution.....	77
Figure 4.13 Joint 2.....	79
Figure 4.14 FBD Joint 2.....	79
Figure 4.15 Joint 2 Stress Graphical Solution.....	80
Figure 4.16 Joint 2 Failure.....	81
Figure 4.17 Joint 3.....	82
Figure 4.18 FBD Joint 3.....	82
Figure B.1: Visual Aid in Calculating Varying Length of Cross Supports.....	98

LIST OF TABLES

Table A.1 Needed and Allowable Loads for Vertical Supports.....92

Table C.1 Post Capacity.....99

SENIOR HONORS THESIS:
PHYSICS

FAILURE AT FIDENAE: VISUALIZATION AND ANALYSIS OF THE LARGEST
STRUCTURAL DISASTER IN THE ROMAN WORLD

REBECCA NAPOLITANO (2015)

ABSTRACT

A digital reconstruction of the amphitheater at Fidenae, which collapsed in 27 A.D., was produced as a result of textual, architectural, archaeological, and engineering analysis. Primary literary sources, such as Tacitus and Suetonius, examined in conjunction with proximal archaeological evidence, allowed for the most probable seating capacity and the scale of the amphitheater to be determined. Architectural evidence of other wooden structures found on Trajan's Column allowed for a most probable projection of a three dimensional model to be created using AutoCAD. With this most probable model determined, engineering analysis was utilized in order to understand the failure at Fidenae almost 2000 years ago.

BACKGROUND INFORMATION

In AD 27 disaster struck the city of Fidenae, located 5 miles north of Romeⁱ, when an amphitheater collapsed killing tens of thousands of people. The work of understanding what most probably happened to the amphitheater at Fidenae is fragmentary, it's piecemeal—but it's possible. It's exciting to put the evidentiary pieces of this amphitheater—the literature, the archaeology, the architectural history, the engineering—finally *together*. Science and Classics are not dissimilar in this way—each commences an intellectual iteration with a small portion of facts and a plethora of unknowns, be they why's, how's, or actual numeric values. This paper seeks to bridge and elucidate the manner in which these disciplines manage their disparate tasks.

Through this work I will attempt to illustrate how historical enigmas can be best understood through the intersection of divergent areas of academia. I will examine primary sources of literature and art where amphitheaters and other wooden constructions are depicted, archaeological evidence of proximal structures, and apply engineering concepts in order to solve the question of what (probably) happened to the amphitheater at Fidenae.

PRIMARY LITERARY SOURCES

The historian Tacitus provides the most detailed account of this catastrophe (Tac. *Ann.* 4.62):

M. Licinio L. Calpurnio consulibus ingentium bellorum cladem aequavit malum improvisum: eius initium simul et finis extitit. nam coepto apud Fidenam amphitheatro Atilius quidam libertini generis, quo spectaculum gladiatorum celebraret, neque fundamenta per solidum subdidit neque firmis nexibus ligneam compagem superstruxit, ut qui non abundantia pecuniae nec municipali ambitione sed in sordidam mercedem id negotium quaesivisset. adfluxere avidi talium, imperitante Tiberio procul voluptatibus habiti, virile ac muliebre secus, omnis aetas, ob propinquitatem loci effusius; unde gravior pestis fuit, conferta mole, dein convulsa, dum ruit intus aut in exteriora effunditur immensamque vim mortalium, spectaculo intentos aut qui circum adstabant, praeceps trahit atque operit. et illi quidem quos principium stragis in mortem adflixerat, ut tali sorte, cruciatum effugere: miserandi magis quos abrupta parte corporis nondum vita deseruerat; qui per diem visu, per noctem ululatus et gemitu coniuges aut

liberos noscebant. iam ceteri fama exciti, hic fratrem, propinquum ille, alius parentes lamentari. etiam quorum diversa de causa amici aut necessarii aberant, pavere tamen; nequedum comperto quos illa vis perculisset, latior ex incerto metus.

In the consulship of Marcus Lucinius and Lucius Calpurnius, an unforeseen catastrophe matched, in both similarity and scale, the death toll of great wars. The beginning and the end of this disaster happened at the same time. For Atilius, a certain man of the class of freedmen, had begun building an amphitheater in which he might celebrate a show of gladiators. He neither placed the foundations under the structure through to solid ground, nor did he build the wooden framework with strong joints. Atilius was the kind of man who undertook the work neither with an abundance of money, nor with the ambition of someone aspiring to make a name for themselves by public service. Rather, he undertook that work for sordid reward. Those eager for such entertainments had been held off at a distance from the enjoyments of shows in the command of Tiberius. A crowd of men and women of all ages, flocked more freely on account of the proximity of the site to the city of Rome. On account of the number of people, the destruction was more grave. A great mass of people had been brought together, and then was torn apart. At the same time, the building rushes inward or is poured out into the exterior parts. It drags headlong and buries an immense force of people, including both those having been attentive to the spectacle and those who were standing around the amphitheater. Those men indeed, whom the beginning of the destruction had crushed to death, escaped torture, as if by a kind twist of fate. More pitiable were those whom life had not yet deserted with part of their body having been ripped from them. More pitiable were those whom by sight during the day and by sounds of wailings and lamentation through the night were recognizing their spouses and children. Already the others were alerted by the news, this one was lamenting a brother, that one was lamenting a neighbor, another was lamenting his parents. Also, those men whose friends and families were away for a different reason, they were nevertheless afraid. With it not yet having been found out whom that force had struck, the fear was more wide spread from uncertainty.ⁱⁱ

Tacitus' description yields information concerning the context of the disaster, what the amphitheater may have looked like, as well as hints as to what may have happened structurally for that type of collapse to have occurred. The literature provides information concerning the number of people, scale of the structure, foundation, joints, et al. which will all be discussed in detail throughout this chapter and later in respective and appropriate chapters.

CAPACITY AND SCALE

Tacitus' account supplies details of political and social significance which augment the understanding of this failure at Fidenae. Granting his audience this contextualized understanding, Tacitus continues by describing the spectators, "As they had been held off at a distance from the enjoyments of shows in the command of Tiberius" (*imperitante Tiberio procul voluptatibus habiti*)ⁱⁱⁱ due to the fact that Tiberius, emperor during the construction and collapse of the amphitheater at Fidenae, did not hold games regularly, the Roman people were "eager for such entertainments" (*avidum talium.*)^{iv} Because of this eagerness, there was an outpouring towards Atilius' amphitheater at Fidenae "on account of the proximity of the site to the city of Rome" (*ob propinquitatem loci.*)^v It is worth noting however, that the word Rome is never expressed in this accusative prepositional phrase. Due to the fact that "Rome" was only 5 miles away and that Tacitus just one line above was discussing Tiberius, who would have been in Rome depriving the people of attending games, it is more than likely that Rome is the city Tacitus is referring to. This outpouring of people—especially if this number was more than expected—would have made an enormous impact on the magnitude of the live load applied to the amphitheater.

But what would the expected live load of the amphitheater have been? In order to answer this question, the literature must be used again as the basis for educated conjecture. From Tacitus' description and the utilization of proximal structures, the general sense of what this amphitheater most probably looked like can be deduced. Aside from mentioning that the framework was comprised of wood, Tacitus refrains from giving any comments on what this amphitheater looked like before the collapse. This could allude to the fact that this amphitheater was not built in an extraordinary way and therefore the framework of the structure should be similar to that of proximal structures. There are two primary methods for building amphitheatres

which Jean-Claude Golvin^{vi} characterizes as “*structure pleine*” and “*structure creuse*.” Which of these methods was the most probable framework for this amphitheater will be one of the topics in Chapter 2.

When considering the literature in order to augment the visualization of this amphitheater, one of the first questions that comes to mind is how large was it? Tacitus’s writing (Tac. *Ann.* 4.63) can be turned to again for more information concerning the possible number of people present at the disaster:

Vt coepere dimoveri obruta, concursus ad exanimos complectentium, osculantium; et saepe certamen si con fusior facies sed par forma aut aetas errorem adgnoscentibus fecerat. quinquaginta hominum milia eo casu debilitata vel obruta sunt; cautumque in posterum senatus consulto ne quis gladiatorium munus ederet cui minor quadringentorum milium res neve amphitheatrum imponeretur nisi solo firmitatis spectatae. Atilius in exilium actus est.

When the ruins began to be removed, there was a rush toward the dead for the purpose of embracing and kissing; and often there was a contest, if appearance was beyond recognition but equal in physical form or age, there was an error for those recognizing (a loved one). 50,000 men were maimed or crushed in that disaster. For the future, by a decree the senate put forth the provision of law that no one could issue forth a show of gladiators to whom less than four hundred thousand sesterces was and they put forth the provision of law that an amphitheater should not be placed unless on ground of having been tested solidly. Atilius was driven into exile.^{vii}

From Tacitus’ description not only are the number of people involved with the failure relayed, but so too are some of the technical details which are left out of Suetonius (Suet. *Tib.* 40,) the only other classical source for this collapse.

Statimque revocante assidua obstestione populo propter cladem, qua apud Fidenas supra viginti hominum milia gladiatorio munere amphitheatri ruina perierant.

And immediately with the people constantly calling back in supplication on account of the disaster, in which at Fidenae over 20,000 men had perished in the collapse of the amphitheater in a gladiatorial show.^{viii}

Among these three passages, there is a good deal of information given which can point to the scale on which the amphitheater must have been built to cause this type of devastation. Tacitus comments, “50,000 people were either hurt or killed in the disaster” (*quinquaginta hominum milia eo casu debilitate vel obrita sunt.*)^{ix} Suetonius remarks “over 20,000 men had perished in the collapse of the amphitheater in a gladiatorial show” (*supra viginti hominum milia gladiatorio munere amphiteatri ruina perierant.*)^x However are the numbers 20,000 and 50,000 exaggerated?

Careful consideration must be given to not only the verbs in these passages, but also to the culture surrounding amphitheaters. Tacitus’ estimation of people deals with those “hurt or killed” (*debilitate vel obrita sunt,*)^{xi} while in comparison, Suetonius’ estimate only deals with those who “had perished” (*perierant.*)^{xii} Therefore it is important to note that these two accounts are not conflicting in the data they are presenting; the literary evidence suggests that the casualty rate was somewhere on the scale of tens of thousands. However this number of people involved needs to be further analyzed and deconstructed. If the cultural aspect of amphitheaters is considered, the number maimed and killed would not have been the full load born by the amphitheater. It was a part of the dominant culture that people would not only have been congregating within the amphitheater, but also they would have been convening outside the amphitheater, utilizing the skeleton of the structure as a covering for other various activities. Tacitus distinguishes the two separate groups of people in the compound sentence where he states, “And headlong, it drags forth those attentive to the spectacle and it buries those who were standing around the amphitheater” (*spectaculo intentos aut qui circum adstabant, praeceps trahit atque operit.*)^{xiii} The amount of people who were most likely inside the amphitheater will be further explored in Chapter 2 and augmented by research into proximal structures.

FOUNDATIONS AND JOINTS

Capacity and scale are not the only aspects of importance when considering what this amphitheater must have looked like; materials are to be considered as well. Despite the fact that Tacitus generally abstains from technical details^{xiv}, there are segments in his writing which provide useful details about the amphitheater in question. Putting it into context of what this amphitheater probably looked like, Tacitus divides the description into two parts: the foundations and the superstructure. According to Tacitus, the foundations of this structure were not placed “through to solid ground” (*per solidum.*)^{xv} This phrase, *per solidum*, could be alluding to the fact that the ground itself was not conducive for building or most likely the fact that the original trenches were not dug to the point where they reached a stable base. Vitruvius, a source for ancient architecture and construction, comments (Vit. *De Architectura* 1.5):

Tunc turrium murorumque fundamenta sic sunt facienda, uti fodiantur, si queat inveniri, ad solidum et in solido, quantum ex amplitudine operis pro ratione videatur.

The next thing to do is to lay the foundations for the towers and the walls. Dig down to solid bottom, if it can be found, and lay them therein, going as deep as the magnitude of the proposed work seems to require.^{xvi}

And Vitruvius also states (Vit. *De Architectura*. 1.3):

Firmitatis erit habita ratio, cum fuerit fundamentorum ad solidum depression, quaque e materia, copiarum sine avarita diligens electio.

Durability will be assured when foundations are carried down to the solid ground and materials are wisely and liberally selected.^{xvii}

Both of these examples include the word “to” (*ad*) in “to the solid bottom” (*ad solidum*) and “to the solid ground” (*ad solidum.*) Tacitus in contrast chooses the phrase “through to solid ground” (*per solidum.*) Since this translation is the primary source of data, technicalities and subtleties will play a major role in the shape of this analysis. *Per* literally means “through to” and could

mean that the foundations were not only laid on ground that seemed suitable, but also they were laid through the soil, meaning deep enough for the magnitude of the structure. *Ad* in contrast denotes a position on the surface. With this difference in definition in mind, it is possible that through the choice of the word *per*, Tacitus is likely conveying that the deficit relating to the soil is not *what* soil Atilius chose to build on, but rather *how deep* he chose to lay his structure. This will be further explored in Chapter 4.

In addition to not laying the foundations properly, Tacitus describes the superstructure and explains that Atilius “did not build the wooden framework with strong joints” (*neque firmis nexibus ligneam compagem superstruxit.*)^{xviii} Considering this technical statement, what does Tacitus mean by “wooden framework” (*ligneam compagem?*) *Ligneam compagem* is the direct object of the word *superstruxit* (“did build”) where *compagem*, according to the Oxford Latin Dictionary (OLD) most nearly means “a composite structure or framework.”^{xix} The fact that *compagem* is modified by the adjective *ligneam* (“wooden”) is intriguing because that means the framework of the amphitheater was most likely made entirely of wood. This had been a practice utilized more so before the evolution of stone amphitheaters; however if Atilius was trying to be frugal about this project, perhaps one of the consequences of cutting costs was that the amphitheater was made entirely of wood. In the literature no technical details are given concerning what shape of framework was utilized in the building of this amphitheater, however proximal structures can be used to estimate what this may have looked like.

In addition to describing the wooden framework, Tacitus also provides technical details concerning the structure’s “strong joints” (*firmis nexibus.*)^{xx} *Firmis nexibus* is an ablative of means where according to OLD, *nexibus* (“joints”) most nearly means “something that fastens, a bond, a joint, etc.”^{xxi} Therefore Tacitus provides the information that Atilius did not build the

wooden framework by means of strong joints. Once the visualization of the wooden framework is better understood, then what these weak joints might have been will be understood as well. In Chapter 3, what the wooden framework looked like will be discussed as well as the types of fastenings which would have been needed to support it, which will be taken up in Chapter 4. From here the discussion will progress in the direction of what must have gone awry structurally.

THEORIES CONCERNING THE COLLAPSE

After yielding information concerning the context of the disaster and what the amphitheater must have looked like, Tacitus's description also provides hints as to what must have happened structurally for that type of collapse to have occurred. Tacitus claims that the beginning and the end of this disaster happened at the same time" (*eius initium simul et finis extitit.*)^{xxii} The words "of the disaster" are not found in the Latin, however *eius* as the subjective genitive of *initium* ("beginning") and *finis* ("end,") is a demonstrative pronoun referring to the *malum improvisum* ("unforeseen catastrophe.") What does it mean that the beginning and the end of the collapse occurred at the same time? It is probable that this collapse was not due to deterioration of the materials and in fact it is probable that it occurred suddenly which is why Tacitus would have chosen to describe it in such a way. This argument will be taken up in Chapters 4 where the analysis of the amphitheater will be presented.

However, is it likely that this amphitheater was actually used before it had been completed? Tacitus remarks that "a certain Atilius of the class of freedman had begun building an amphitheater in which he might celebrate a show of gladiators" (*nam coepto apud Fidenam amphitheatro Atilius quidam libertini generis, quo spectaculum gladiatorum celebraret.*)^{xxiii} From the diction "having been begun" (*coepto,*) Tacitus could be telling the reader that Atilius had started an amphitheater, and it could simply be implied that it was finished before it was opened

to the public. Employing an ablative absolute here, Tacitus makes it unclear whether this ablative absolute governs the entire description or not and therefore how this should be translated. It is a compelling argument that Tacitus utilized the word *coepto* (“having been begun”) because that is exactly what this amphitheater was—only begun and not yet finished. By modern standards, this practice seems foreign; there are a plethora of inspections and several layers of red tape to go through before a building can be opened to the public. Lacking this love of red tape, it was not uncommon for the Romans to open a building to the public before completion.^{xxiv} The varying degrees of completion however would have yielded divergent results—either a stable or unstable structure.

As far as how far along this construction might have been when the amphitheater opened, Tacitus does yield some context clues. When Tacitus remarks that the amphitheater “headlong drags forth and buries” (*praeceps trahit atque operit*,)^{xxv} this gives a small indication as to how large this amphitheater had to have been. If the amphitheater had only been a few sections of seats high that would hardly produce a force large enough to drag its victims headlong. From these verbs it can be concluded that this amphitheater must have been on a large scale for Tacitus to have described the collapse in such a way; therefore that suggests that the collapse was due to an engineering failure rather than the amphitheater not being completed. This will be further discussed in Chapter 2.

ⁱTacitus. *Tacitus: Annals Book I-IV*. Comp. R.H. Martin and A.J. Woodman. (Cambridge University Press, New York, 2006), p 234.

ⁱⁱ Tacitus. *Annales 4.62* in Tacitus. *Tacitus: Annals Book I-IV*. Comp. R.H. Martin and A.J. Woodman. Trans. Rebecca Napolitano. (Cambridge University Press, New York, 2006).

ⁱⁱⁱIbid.

^{iv}Ibid.

^vIbid.

^{vi} Jean-Claude Golvin. *L'Amphitheatre Romain: Essai sur la Theorsation de sa Forme et de ses Fonctions*. Trans. Caeli Smith. (Diffusion de Boccard, Paris, 1988), p. 157-224.

-
- ^{vii}Tacitus. *Annales* 4.63 in Tacitus. *Tacitus: Annals Book I-IV*. Comp. R.H. Martin and A.J. Woodman. Trans. Rebecca Napolitano. (Cambridge University Press, New York, 2006).
- ^{viii}Suetonius. *Tib. 40* in Suetonius. *Life of Tiberius*. Comp. Mary Johnstone Du Four and Joannes Renier Rietra. Trans. Rebecca Napolitano. (Arno Press, New York, 1979).
- ^{ix}Tacitus. *Annales* 4.63 in Tacitus. *Tacitus: Annals Book I-IV*. Comp. R.H. Martin and A.J. Woodman. Trans. Rebecca Napolitano. (Cambridge University Press, New York, 2006).
- ^xSuetonius. *Tib. 40* in Suetonius. *Life of Tiberius*. Comp. Mary Johnstone Du Four and Joannes Renier Rietra. Trans. Rebecca Napolitano. (Arno Press, New York, 1979).
- ^{xi}Tacitus. *Annales* 4.63 in Tacitus. *Tacitus: Annals Book I-IV*. Comp. R.H. Martin and A.J. Woodman. Trans. Rebecca Napolitano. (Cambridge University Press, New York, 2006).
- ^{xii}Suetonius. *Tib. 40* in Suetonius. *Life of Tiberius*. Comp. Mary Johnstone Du Four and Joannes Renier Rietra. Trans. Rebecca Napolitano. (Arno Press, New York, 1979).
- ^{xiii} Ibid.
- ^{xiv}Tacitus. *Tacitus: Annals Book I-IV*. Comp. R.H. Martin and A.J. Woodman. (Cambridge University Press, New York, 2006), p 234.
- ^{xv}Tacitus. *Annales* 4.62 in Tacitus. *Tacitus: Annals Book I-IV*. Comp. R.H. Martin and A.J. Woodman. Trans. Rebecca Napolitano. (Cambridge University Press, New York, 2006).
- ^{xvi}Vitruvius. *De Architectura* 1.5. in Vitruvius: *Ten Books on Architecture*. Comp. and Trans. Ingrid D. Rowland and Thomas Noble Howe. (Cambridge University Press, New York, 1999.)
- ^{xvii}Vitruvius. *De Architectura* 1.3. in Vitruvius: *Ten Books on Architecture*. Comp. and Trans. Ingrid D. Rowland and Thomas Noble Howe. (Cambridge University Press, New York, 1999.)
- ^{xviii}Tacitus. *Annales* 4.62 in Tacitus. *Tacitus: Annals Book I-IV*. Comp. R.H. Martin and A.J. Woodman. Trans. Rebecca Napolitano. (Cambridge University Press, New York, 2006).
- ^{xix}P.G. W. Glare. *Oxford Latin Dictionary*, (Oxford University Press, United Kingdom, 2012), p372.
- ^{xx}Tacitus. *Annales* 4.62 in Tacitus. *Tacitus: Annals Book I-IV*. Comp. R.H. Martin and A.J. Woodman. Trans. Rebecca Napolitano. (Cambridge University Press, New York, 2006).
- ^{xxi}P.G. W. Glare. *Oxford Latin Dictionary*, (Oxford University Press, United Kingdom, 2012), p. 1175.
- ^{xxii}Tacitus. *Annales* 4.62 in Tacitus. *Tacitus: Annals Book I-IV*. Comp. R.H. Martin and A.J. Woodman. Trans. Rebecca Napolitano. (Cambridge University Press, New York, 2006).
- ^{xxiii}Tacitus. *Annales* 4.62 in Tacitus. *Tacitus: Annals Book I-IV*. Comp. R.H. Martin and A.J. Woodman. Trans. Rebecca Napolitano. (Cambridge University Press, New York, 2006).
- ^{xxiv}Phillips, Darryl A. *Tertullian on the Opening of Pompey's Theater in Rome*. *Syllecta Classica*, Volume 12 (2001), pg. 208-220.
- ^{xxv}Tacitus. *Annales* 4.62 in Tacitus. *Tacitus: Annals Book I-IV*. Comp. R.H. Martin and A.J. Woodman. Trans. Rebecca Napolitano. (Cambridge University Press, New York, 2006).

CHAPTER 2: “DID THAT MANY PEOPLE *REALLY* DIE?”

In this chapter, proximal structures for the purpose of generating the most probable design for the amphitheater at Fidenae will be examined. The word proximal is not limited to the concept of geographic proximity; rather it pertains to the concept of how closely an amphitheater’s method and motivation for construction as well as seating capacity relate to the amphitheater at Fidenae as given by the primary literary sources. The overall typology and seating capacity of the amphitheater will be established through analyzing for what purpose this structure was created, the manner in which Tacitus claims it collapsed, and then by comparing this information with data from proximal structures.

MOST PROBABLE TYPOLOGY

In his work *L’Amphitheatre Romain*, Golvin discusses a dichotomous typology pertaining to Roman amphitheaters: *a structure pleine* and *a structure creuse*.ⁱ For an amphitheater to be characterized as *structure pleine* means that it is not a hollow structure; it is generally either formed from natural slopes in the terrain or augmented through excavating a site and building the structure directly into the ground. The *cavea* in these amphitheaters could have been made by placing timber or stone into the natural hillsides; in addition it could have been hewn from the existing rock. These structures were considered to be more heavy, compact, and stable in comparison with *a structure creuse*.ⁱⁱ Not being built into the hillsides or formed from solid fill, the *structure creuse* are hollow structures which could be built irrespective of an area’s topography. These structures were generally larger yet more expensive than the *structure pleine*.ⁱⁱⁱ

In the case of the amphitheater at Fidenae, *structure creuse* seems to be the most probable construction type of the two. Despite the fact that Brill’s *New Pauly* describes Fidenae as an area

characterized by hills which would be suitable for *structure pleine*, the primary literary sources of this collapse strongly suggest *structure creuse*.^{iv} In the passage from Tacitus, it is stated that the amphitheater “drags headlong and buries and immense force of people, including both those having been attentive to the spectacle and those who were standing around the amphitheater.” (*immensameque vim mortalium, spectaculo intentos aut qui circum adstant, praeceps trahit atque operit.*)^v The fact that the amphitheater can bury those who were outside seems to convey the impression that this amphitheater was not dug into the ground and was a structure that would have had *fornixes* in which people could engage in shopping and various other activities around the perimeter and under the framework of the structure.

In addition the description of the collapse is very telling. Tacitus claims that “at the same time, the building rushes inward or is poured out into the exterior parts” (*dum ruit intus aut in exteriora effunditur.*) This type of collapse could have precipitated from a design where the structure was comprised of two main sections of the wooden framing. If these sections were not joined well this could have led to the upper half of the frame splitting from the lower in a manner in which one of the sections could have fallen inwards towards the arena and the other half could have fallen outwards crushing those around the perimeter. This theory is supported by Tacitus’ comment that “Atilius did not build the wooden framework with strong joints” (*neque firmis nexibus ligneam compagem superstruxit.*) The joints indicated in Tacitus could be referring to individual joints; however with the description of the devastation, a bifurcation of the framework at the joints between the upper and lower sections of the amphitheater seems more likely. This idea will be discussed in more depth in Chapter 4.

MOST PROBABLE SEATING CAPACITY

With the most probable shape and typology determined, a subsequent point of inquiry is how large would this structure have been. A strong indicator for amphitheater size is seating capacity which, due to the relevant data available, can be determined from two different sources: Proximal Archaeological Evidence and Primary Literary Evidence. The literary evidence of Suetonius and Tacitus suggests that the amphitheater at Fidenae was somewhere on the scale of 20,000 to 50,000 people. With this scale being so vast, in order to determine a more probable estimate for the seating capacity, it is necessary to consult archaeological findings from proximal amphitheaters.

ARCHAEOLOGICAL EVIDENCE

Jean-Claude Golvin's work, *L'Amphitheatre Romain: Essai sur la Theorisation de sa Forme et de ses Fonctions*, is the primary source of the data used to determine the size of the amphitheater at Fidenae from an archaeological approach. Included in the text is the graph where Golvin depicts the seating capacity as a function of the overall area of the structure.

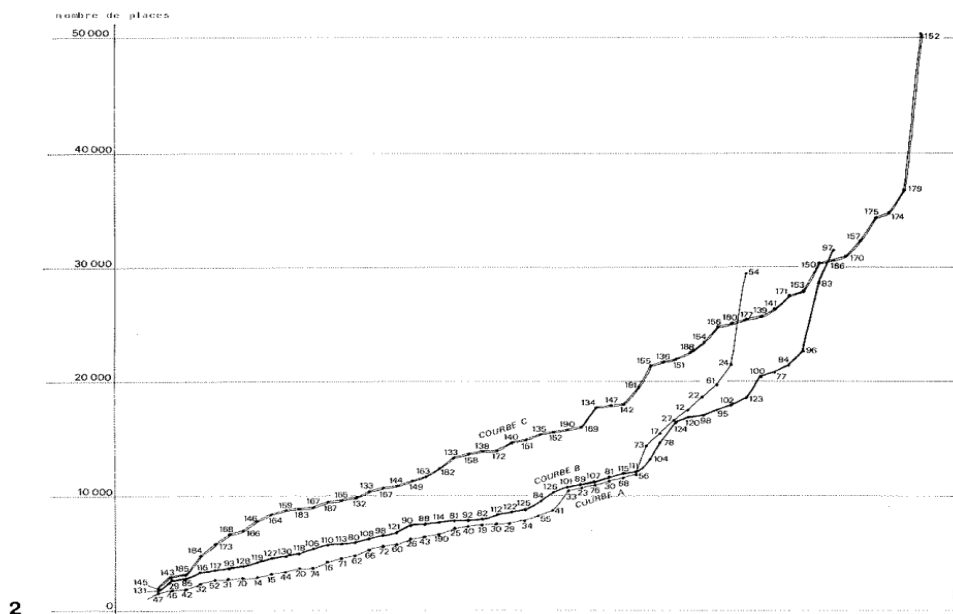

Figure 2.1: Graph of Seating Capacity versus Overall Area^{vi}

In looking at this graph, lines A and B are the “full” amphitheaters or *a structure pleine*, while line C is comprised from the data of the “hollow” amphitheaters, or *a structure creuse*. It has already been established that a “hollow” amphitheater seems much more likely for the amphitheater at Fidenae and therefore the proximal structures can be found on line C. Considering 44 amphitheaters in the *structe creuse* style, the median seating capacity is found to be 15,544 people. However, if the range for possible amphitheater values is set using the numbers provided in the literature, 20,000 and 50,000, these 44 amphitheaters include ones that are not close to the probable scale. Therefore upper and lower limits should be incorporated in order to find a median value which is more probable based upon what is known, rather than just a median value which represents all a *structe creuse* amphitheaters. According to the archaeological evidence, the median seating capacity for amphitheaters greater than 20,000 and less than 50,000 is 28,900 people. Furthermore, the data presented by Golvin can also be used to see relationships between seating capacity and overall area, overall dimensions, arena area, arena dimensions, and width of *cavea*.

The first graph, derived from the data found in Golvin, suggests that there is a very strong correlation between the overall area and seating capacity ($R^2=0.9871$.)^{vii}

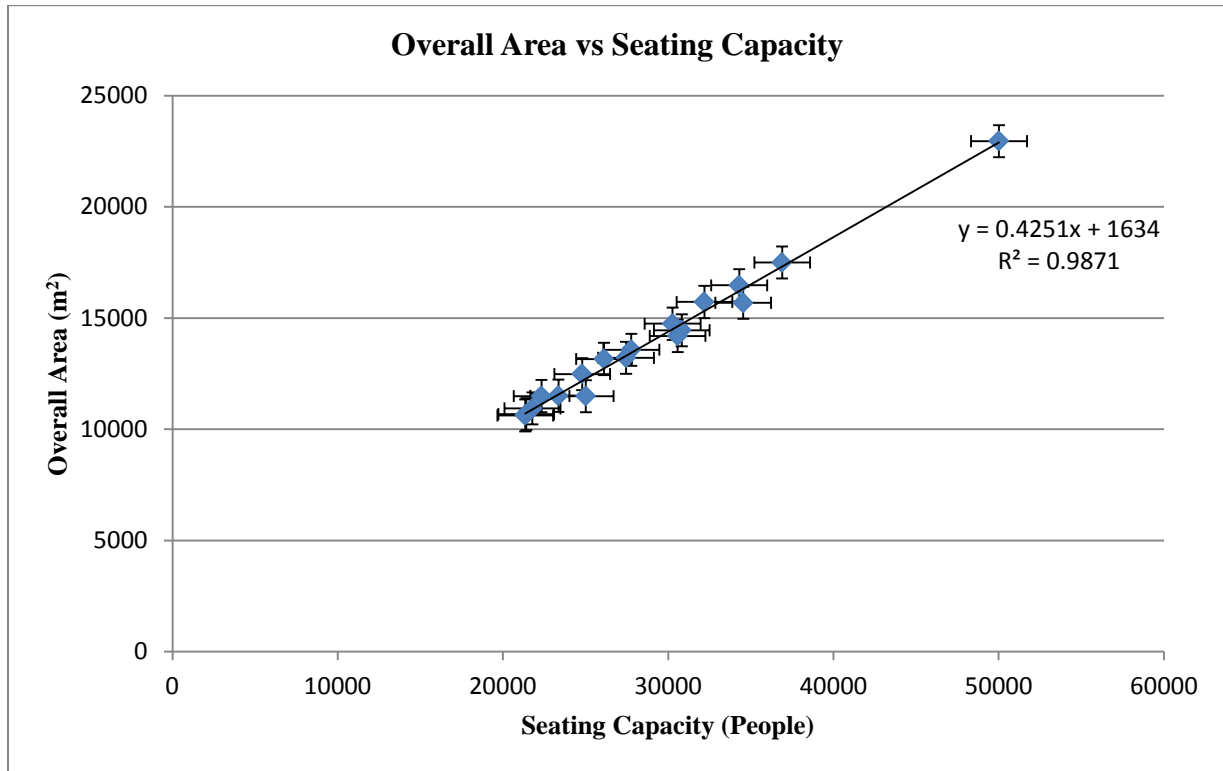

Figure 2.2 Graph of Overall Area vs. Seating Capacity

The equation which represents the line of best fit through the data points, which are representative of the overall area of the amphitheater versus the seating capacity, is as follows.

$$St = 0.4251Pl + 1634 \quad \text{Eq. (2.1)}$$

Where: St =Overall Area or Area of the Entire Amphitheater (m^2)

Pl =Seating Capacity.

There is also a strong correlation between the major axis and the seating capacity ($R^2=0.9788$) as well as between the minor axis and the seating capacity ($R^2=0.9539$.)^{viii}

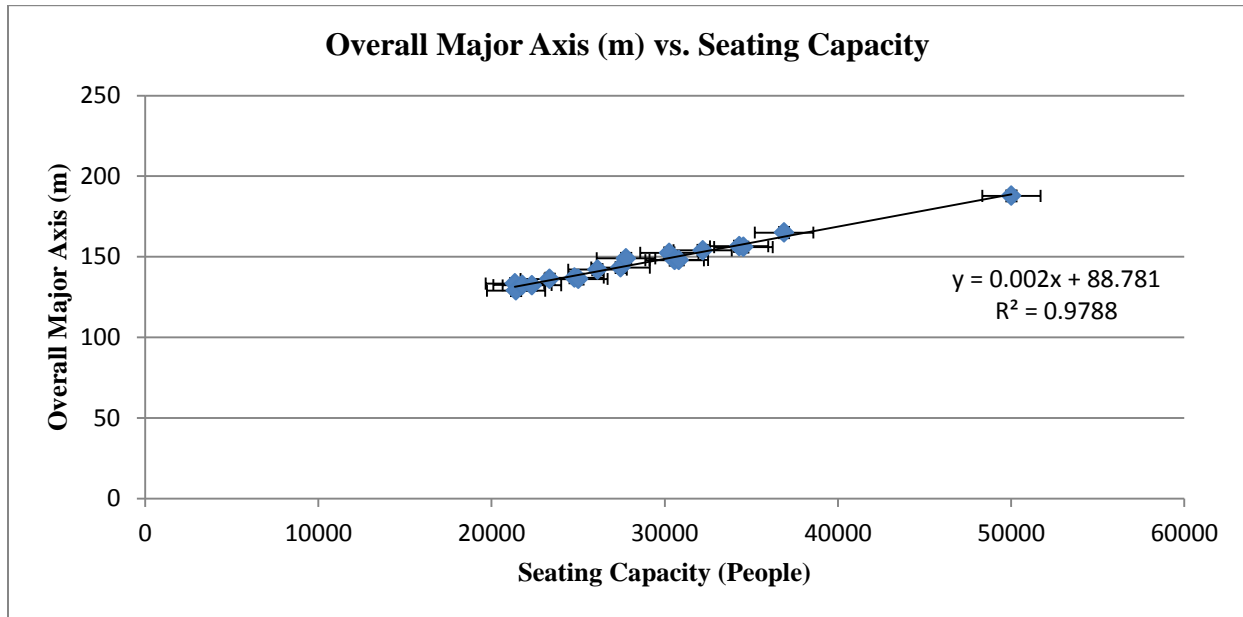

Figure 2.3 Graph of Overall Major Axis vs. Seating Capacity

The equation which represents the line of best fit through the data points, which are representative of the overall major axis of the amphitheater versus the seating capacity, is as follows.

$$A = 0.0018Pl + 66.416 \quad \text{Eq. (2.2)}$$

Where: A=Major Axis of the Entire Amphitheater (m).

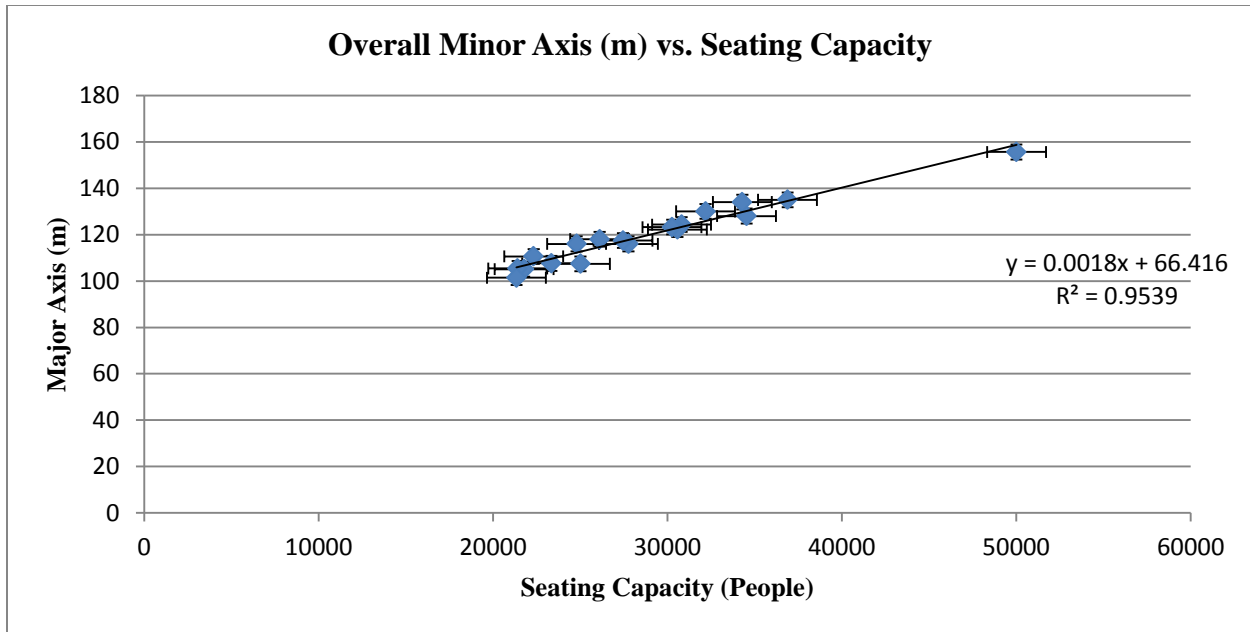

Figure 2.4 Graph of Overall Minor Axis versus Seating Capacity

The equation which represents the line of best fit through the data points, which are representative of the overall minor axis of the amphitheater versus the seating capacity, is as follows.

$$B = 0.0018Pl + 66.416 \quad \text{Eq. (2.3)}$$

Where: B=Minor Axis of the Entire Amphitheater (m).

In addition to establishing a relationship between overall dimensions and seating capacity, next a relationship between the area of the arena, its dimensions, and the seating capacity can be established. However unlike the strong correlation between the overall area, dimensions, and the seating capacity, there is not a strong relationship between those of the arena due to how disparately arenas were built. Arenas varied greatly with respect to dimensions depending on what the purpose of the amphitheater was as well as to conform to certain geographic and topographical constraints. The lack of correlation can be seen in the low R^2 values corresponding to the graphs which follow. ^{ix}

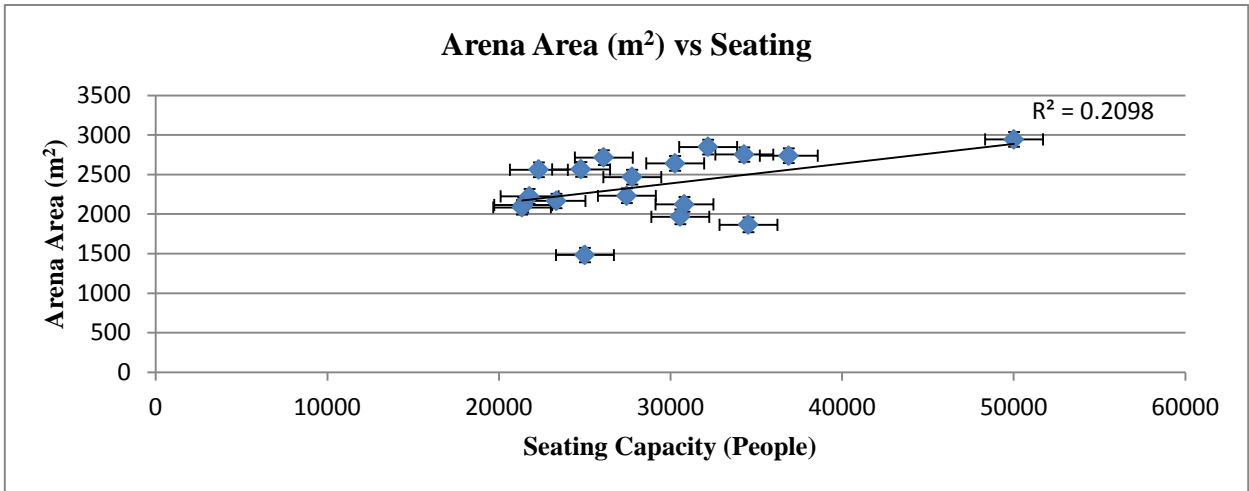

Figure 2.5 Graph of Arena Area versus Seating Capacity

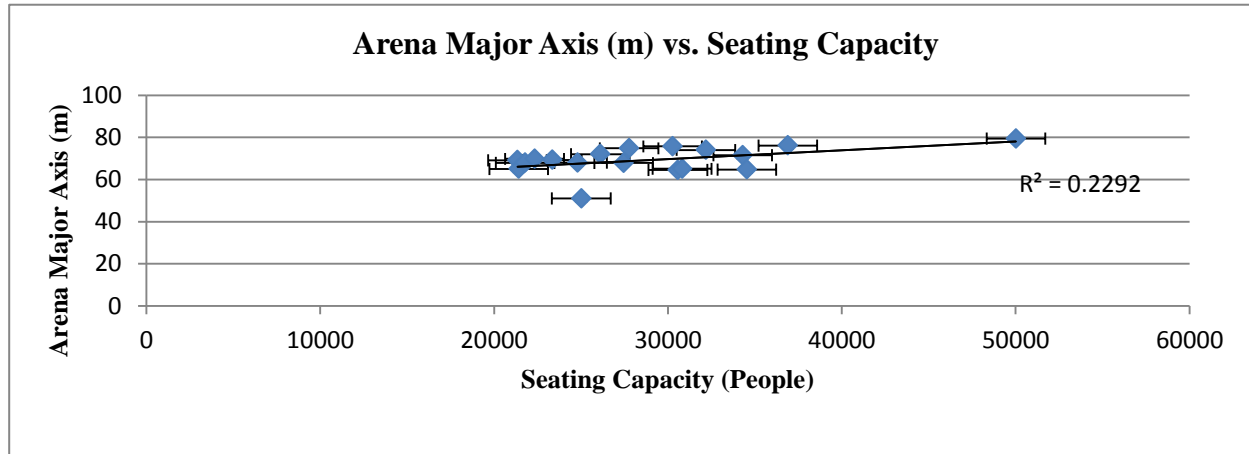

Figure 2.6 Graph of Arena Major Axis versus Seating Capacity

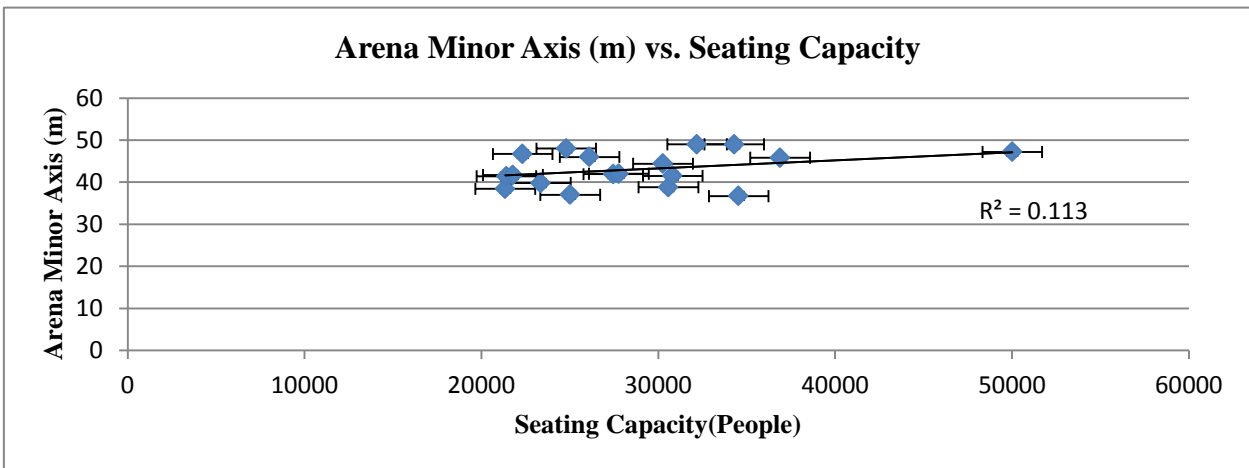

Figure 2.7 Graph of Arena Minor Axis versus Seating Capacity

In order to understand how much of the total area would have been dedicated to the arena, consider the width of the *cavea* which has a strong correlation with seating capacity ($R^2=0.8799$.)

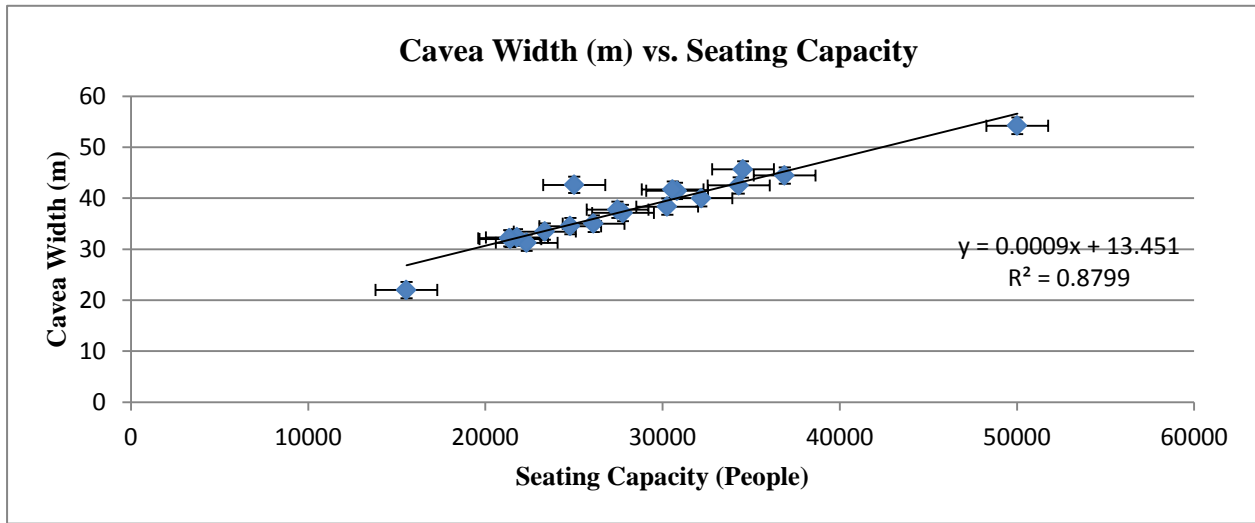

Figure 2.8 Graph of Cavea Width versus Seating Capacity

The equation which represents the line of best fit through the data points, which are representative of the *cavea* width versus the seating capacity, is as follows.

$$C = 0.009P + 13.451 \quad \text{Eq. (2.4)}$$

Where: C=Width of the *cavea* (m).

Once the width of the *cavea* has been determined, the dimensions of the arena can be found from the following formulae. These formulae emanate from the fact that the dimensions of the overall amphitheater are equal to the dimensions of the arena plus twice the width of the *cavea*. The width of the *cavea* is multiplied by two due to the fact that the width of the seating area has to be accounted for on both sides of the ellipse.

$$a = A - 2C \quad \text{Eq. (2.5)}$$

$$b = B - 2C \quad \text{Eq. (2.6)}$$

Where: a=Major Axis of the Arena (m)

b=Minor Axis of the Arena (m).

LITERARY EVIDENCE

If the numbers found in the literary evidence are held to be completely factual, then it should be surprising to see a seating capacity estimate of 28,900 people—this number is far less than Tacitus' remarked 50,000 people maimed and killed. Granted, Tacitus' and Suetonius' numbers could be hyperbolic. However, for the moment if we assume Tacitus' estimate of 50,000 people maimed and killed is accurate how many people would that yield in terms of seating capacity?

The following equation is based upon the assumption that everyone inside the amphitheater, or everyone who made up the seating capacity, was maimed or killed. This number encompasses those inside and outside the amphitheater at the time of the collapse, and in order to establish what portion of the 50,000 were inside the amphitheater a formula has been created which utilizes Eqs. 2.1-2.6:

$$PI+EC=50000 \qquad \text{Eq. (2.7)}$$

Where: EC=External Casualties.

In order to calculate the amount of external casualties it is imperative to have a rudimentary understanding of how this amphitheater may have collapsed. The way in which Tacitus describes the collapse alludes to the fact that the amphitheater underwent a bifurcation, “At the same time, the building rushes inward, or is poured out into the exterior parts. It drags headlong and buries an immense force of people, including both those having been attentive to the spectacle and those who were standing around the amphitheater” (“...*dum ruit intus aut in exteriora effunditur immensamque vim mortalium, spectaculo intentos aut qui circum adstabant, praeceps trahit atque operit.*”)^x The number of external casualties can be further broken down into those who were standing outside the perimeter of the amphitheater and those within the

shops or engaging in various other activities under the framework of the amphitheater. Therefore the equation expands to the form which follows:

$$PI+(SC+PC)=50000 \quad \text{Eq. (2.8)}$$

Where: SC=Shop Casualties

PC= Perimeter Casualties

The following figure illustrates the areas where external casualties could have occurred.

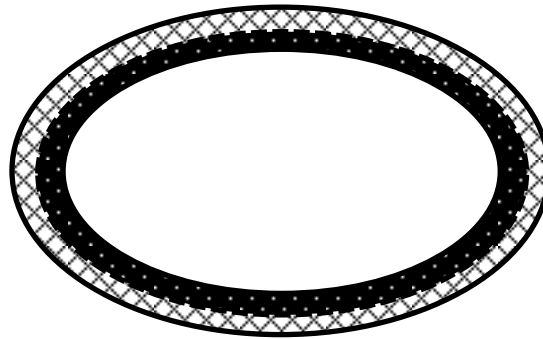

Figure 2.9 Ellipse Nomenclature: This figure is not to scale for the purposes of easily illustrating the different areas. The dashed line represents where the amphitheater would have stood prior to collapsing, the area represented by the dark, dotted ring depicts the area of people making up the SC term under the framework of the structure, and the area represented by the hatched outer ring depicts the area of people making up the PC term standing outside the perimeter of the amphitheater. For the purposes of the derivation, the innermost ellipse will be referred to as the primary ellipse, the ellipse created by the dashed line will be referred to as the secondary ellipse, and the outermost ellipse will be referred to as the tertiary ellipse.

The estimated the depth of the shops, based off of modern carnival structures, is represented by the width of the dark, dotted ring, and is valued at 3.048m.^{xi} The probable area of people who would have been in the shops under the framework can be found by subtracting the area of the primary ellipse, from the area of the secondary ellipse. The area of the primary ellipse is found by taking the difference of the dimensions of the standing arena, or the secondary ellipse, and twice shop depth. The reason twice the shop depth is taken is because the values for the major

and minor axes of the overall amphitheater span the entire cross section as opposed to just measuring radially.

$$\frac{\pi AB}{4} - \frac{\pi(A-2(3.048m))(B-2(3.028m))}{4} = AF \quad \text{Eq. (2.9)}$$

Where: A=Major Axis of the Overall Amphitheater (m)

B=Minor Axis of the Overall Amphitheater (m)

AF= Area under the framework (m²)

This equation will yield the area of people maimed or killed under the framework of the amphitheater; however the area of people maimed or killed on the perimeter of the amphitheater needs to be determined as well. In order to establish this however, what portion of the amphitheater “is poured out into the exterior parts” (*in exteriora effunditur*) must be determined.^{xiii} There is a lack of definitive evidence for the building methods and design of wooden amphitheaters; however it is well-accepted that the design of many stone amphitheaters would have been a close estimate to the original wooden ones they might have replaced.^{xiii} Due to the fact that there is no known later stone phase of the amphitheater at Fidenae, for the purposes of this paper an artistic representation of a partial wooden amphitheater on Trajan’s Column will instead be considered; this depiction will be utilized to form a basic understanding of a possible design and where the amphitheater most likely failed.^{xiv}

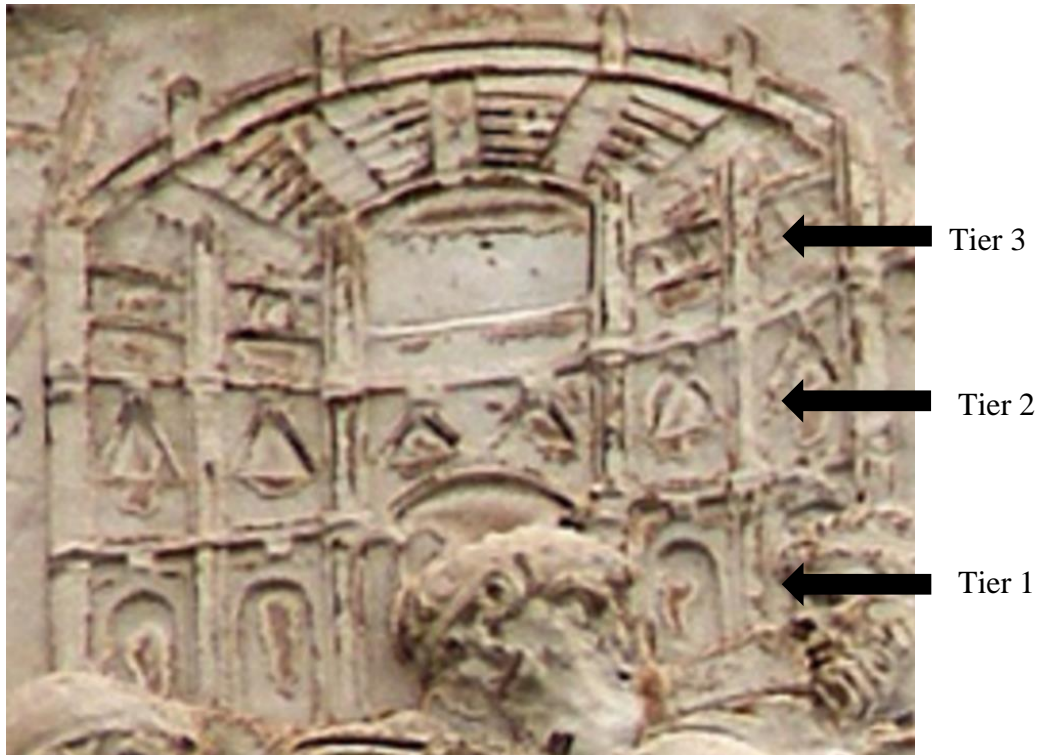

Figure 2.10 Depiction of Wooden Amphitheater on Trajan's Column

This amphitheater, discussed by Frank Lepper and Sheppard Frere in the book, *Trajan's Column*, consists of three different tiers. Tiers 2 and 3 are made up of wood, while Tier 1 was built from stone; this is where the illustration differs from the amphitheater at Fidenae.^{xv} Due to the fact that Tacitus does not mention any stone being utilized in the construction, it has been assumed that the entirety of the amphitheater at Fidenae consisted of wood. With this difference set aside however, it will be presumed that the amphitheater at Fidenae was constructed in a similar fashion with three tiers. As Tacitus remarks, one of the causes of the collapse were the weak joints (*neque firmis nexibus ligneam compagem superstruxit.*)^{xvi} At this point a seed method of collapse will be considered as a part of a feedback loop to determine the primary characteristics of the amphitheater. The seed is the assumption that the amphitheater bifurcated between Tier 1 and Tier 2. In addition at this point the direction each section would have fallen must be conjectured; for the moment, it will be assumed that the bottom third fell outward while

the top two thirds fell inward. These assumptions will be revisited and reexamined in Chapter 4 when the cause of the collapse is determined.

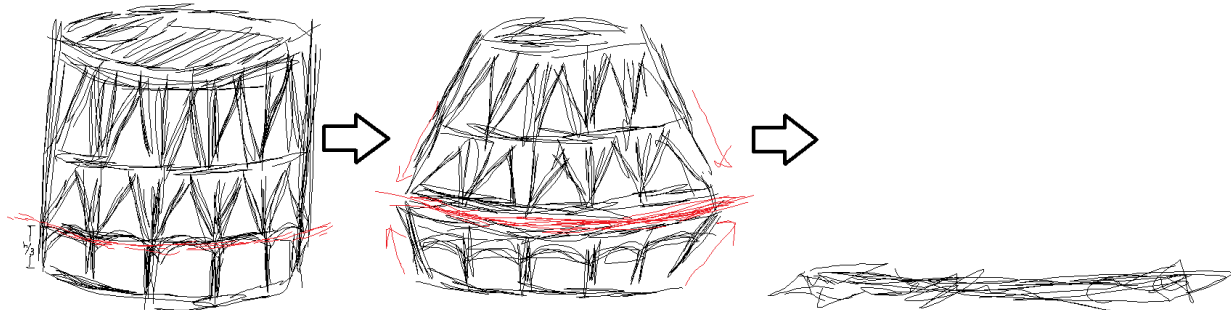

Figure 2.11 Collapse Theory 1: This figure illustrates the concept discussed above. The red line in between Tiers 1 and 2 is where the weakest joints have been assumed to be. The bottom third of the amphitheater falls outward while the upper two thirds of the amphitheater fall inward as illustrated by the second drawing in the figure.

Since the seating capacity will be utilized to determine the height later on in this chapter, it is necessary to select an amphitheater that up to this point seems to be proximal and for which the height is recorded. The amphitheater at Verona with a seating capacity of 30,266 falls on the scale established by the literature (20,000-50,000) and falls under the category of a *structure creuse* like the amphitheater at Fidenae; therefore it will be considered proximal enough to provide an insight as to the height of the amphitheater at Fidenae.^{xvii} The height of the amphitheater at Verona is 30.48m and therefore the number representing one-third of the probable height of the amphitheater at Fidenae is 10.16m.^{xviii} If this height is multiplied by the circumference of the standing amphitheater, it can be determined what area the structure would have collapsed onto, and from there, how many people this portion of the collapse may have maimed or killed. The approximation for the circumference of an ellipse is as follows^{xix}:

$$2\pi\sqrt{\frac{(\frac{A}{2})^2+(\frac{B}{2})^2}{2}} \approx C \quad \text{Eq. (2.10)}$$

Where A=Major Axis of the Overall Amphitheater (m)

B=Minor Axis of the Overall Amphitheater (m)

C=Circumference of the Overall Amphitheater (m)

If this equation is multiplied by the height of the bottom third of the amphitheater, 10.16m, this represents the area that could have been crushed by the amphitheater “rushing outwards.”

$$2\pi(10.16m)\sqrt{\frac{(\frac{A}{2})^2+(\frac{B}{2})^2}{2}} \approx PA \quad \text{Eq. (2.11)}$$

Where PA=Area affected by the collapse outside the perimeter of the structure (m²)

However AF and PA just represent areas and do not represent the amount of people who would have been congregating in that area. In order to calculate that, consider Jacob’s Method for counting crowds. By this method it has been established that a loose crowd can be defined by a population density of 10 ft² per person and that a densely packed crowd can be defined by a population density of 4.5 ft² per person.^{xx} If it is not assumed that the crowd would have been at the extremes of a loose or a dense crowd, the mean of the values of those densities can be utilized in order to find a probable crowd density, it can be found that 1.734 people would most likely be in one square meter. By multiplying this crowd density by the areas established above, the number of people maimed or killed outside the perimeter and under the framework can be found.

$$SC = AF\rho \quad \text{Eq. (2.12)}$$

$$PC = PA\rho \quad \text{Eq. (2.13)}$$

Where ρ =Crowd density (people/m²)

If Eqs. 2.9 and 2.11 are substituted into Eqs. 2.12 and 2.13 and in turn Eqs. 2.12 and 2.13 are then substituted into Eq. 2.8, the following equation is the result:

$$Pl + \left(\frac{\pi AB}{4} - \frac{\pi(A-2(3.048m))(B-2(3.028m))}{4} \rho \right) + 2\pi\rho(10.16m) \sqrt{\frac{\left(\frac{A}{2}\right)^2 + \left(\frac{B}{2}\right)^2}{2}} = 50000 \quad \text{Eq. (2.14)}$$

This equation is still in terms of the major and minor axes of the overall amphitheater however. In order to have an equation entirely as a function of the seating capacity, Eqs. 2.2 and 2.3 are inserted into Eq. 2.14 with the follow equation as the result:

$$Pl + \left(\frac{\pi(0.002Pl+88.781)(0.0018Pl+66.641)}{4} - \frac{\pi((0.002Pl+88.781)-2(3.048m))((0.0018Pl-66.641)-2(3.028m))}{4} \right) 1.734 \frac{\text{people}}{m^2} + (2\pi)1.734 \frac{\text{people}}{m^2} (10.16m) \sqrt{\frac{\left(\frac{0.002Pl+88.781}{2}\right)^2 + \left(\frac{0.0018+66.641}{2}\right)^2}{2}} = 50000 \quad \text{Eq. (2.15)}$$

By solving this equation for Pl, it can be found that for a total of 50,000 to be involved in this collapse, the seating capacity would be 45,800 people.

45,800 people is a much different estimate than 28,900 people and it seems like these two estimates would be describing completely different amphitheaters. However it is most probable that the actual seating capacity of the amphitheater lies somewhere in the middle of the numbers found by the proximal archaeological and literary approaches. Based upon the literary evidence and the numbers put forth by Tacitus and Suetonius, it does not seem like the amphitheater would have been on the scale of the median of the known *structe creuse* data, 28,900 people. However based upon the archaeological evidence, it is not probable that the amphitheater would have been on the scale of 45,800 people either—the only *structe creuse* amphitheater on that scale is the Coliseum. It is improbable that that the amphitheater was on the scale of the

Coliseum due to the fact that if it were indeed that large it would have most likely been noted elsewhere in art or literature and not just mentioned in the context of its collapse. If both of these numbers are weighted equally an estimate for seating capacity, based upon both the literary and archaeological evidence, can be determined to be 37,400 people. This number validates the use of the amphitheater at Verona as a proximal structure due to the fact that they are close in seating capacity.

TWO-DIMENSIONAL LAYOUT

Based on a seating capacity of 37,400 people and Eqs. 2.2-2.6, the dimensions of the major and minor axes of both the overall amphitheater and the arena as well as the width of the *cavea* can be determined for the amphitheater at Fidenae. Dimensions of the amphitheater are depicted below.

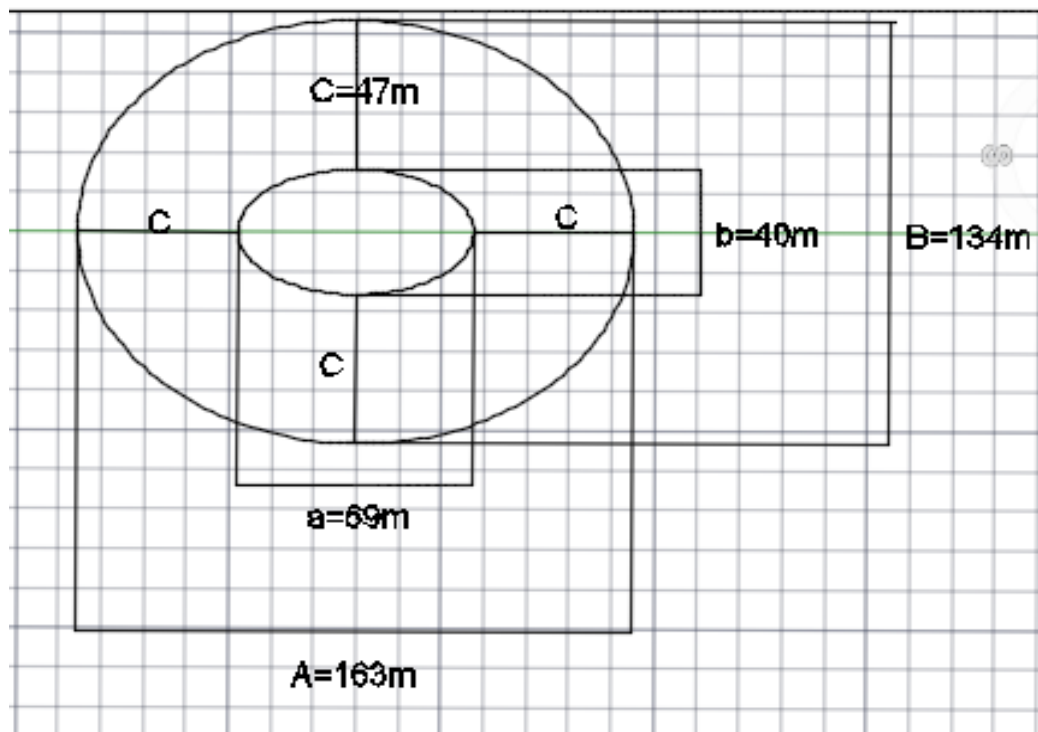

Figure 2.12 Two Dimensional Layout: Most probable dimensions based upon seating capacity of 37,400 people at the amphitheater at Fidenae.

MOST PROBABLE HEIGHT OF THE AMPHITHEATER AT FIDENAE

In order to determine a probable height of the amphitheater at Fidenae, again consider the amphitheater at Verona. According to the calculations above, the amphitheater at Fidenae would have sat 37,350 people where Verona would have sat 30,266 people.^{xxi} There are proximal structures which are closer in capacity to the amphitheater at Fidenae, however a sketch of the cross sectional area of the amphitheater was desired in order to determine approximate heights and widths of seats, number of seats, width of walkways, height of the back wall, as well as height of the arena wall.

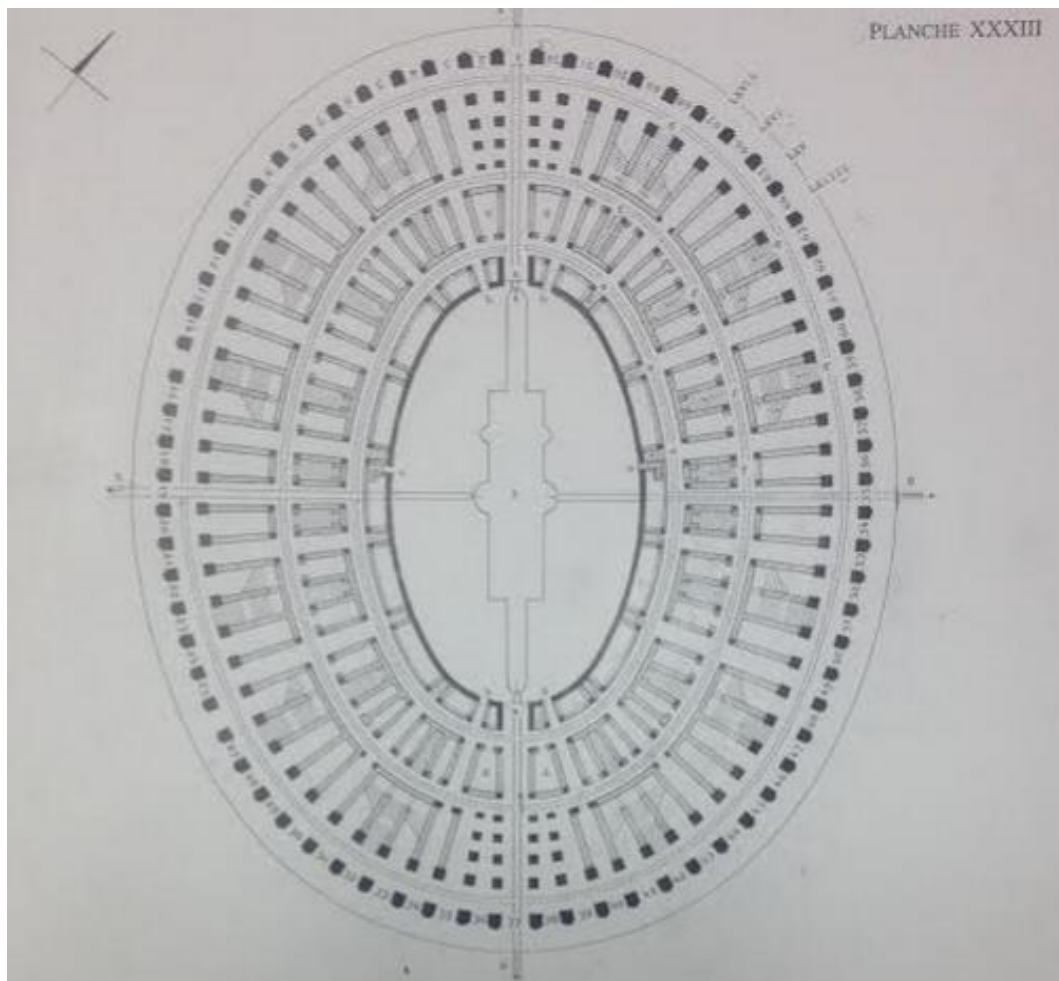

Figure 2.13: Top View Amphitheater at Verona.^{xxii}

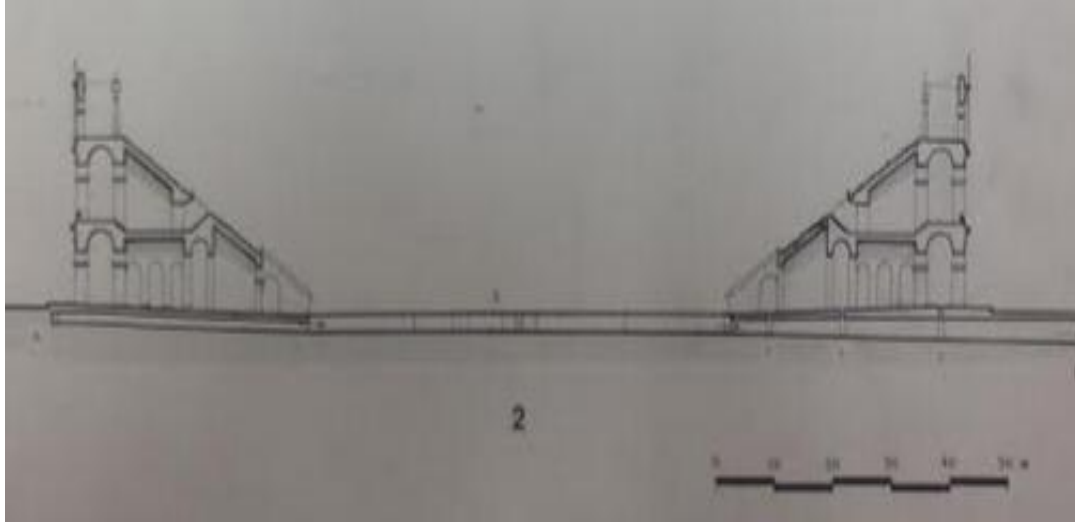

Figure 2.14: Cross-sectional View Amphitheater at Verona. ^{xxiii}

From the diagram of the amphitheater at Verona it can be established that the height of each seat was approximately 0.53m, the width of each seat was approximately 0.63m, that there are 35 rows of seats in total, the walk ways are 3.55m wide, the back wall rose to 10m above the third tier of seats, whereas the wall of the arena rose to 2.5m. ^{xxiv}

As can be seen in Figure 2.15, the width of the *cavea* for the amphitheater at Fidenae was established to be 47m. After subtracting out the area distance for walkways (3.55m), arena wall width (2.5m), and back wall width (2.5), as well as the sections which separate the walkways from the seating (1.5m) there are 28.35m left for the seating areas. If each seat is 0.63m wide, then that would leave room for 45 rows of seats total. The sketch which follows represents the cross-sectional area of the *cavea*.

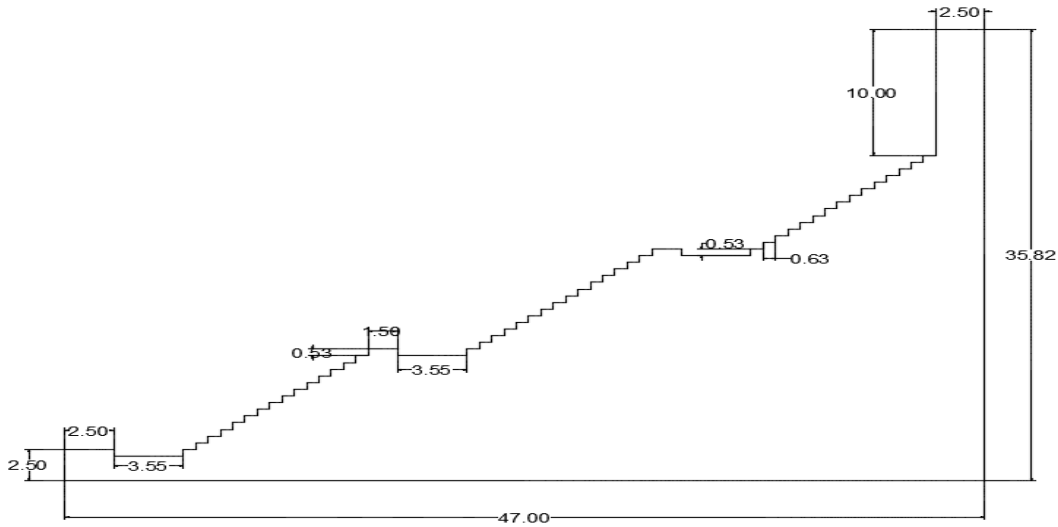

Figure 2.15: Cavea Cross-Section; all numbers are represented in meters.

From this figure it is possible to establish the height of the overall amphitheater. If the height of each seat is 0.53m then the seats make up a height of 23.85m and if the height of the back wall (10m) as well as the height of the arena wall (2.5m) are added to that number, then the final height of 35.85m can be found. However it must be noted that the height of the first seat is 0.03m above the 2.50m arena wall. This is why the actual height of the amphitheater is 35.82m as opposed to 35.85m. This is due to the fact that there is a drop in the 0.5m from the top of the arena wall to the walkway, and then a subsequent rise of 0.53m in the seat after the walkway, making for a positive net height of 0.03m. The height of the amphitheater at Fidenae seems reasonable when compared with the height of Verona, a slightly smaller amphitheater at 30.48m, and the Coliseum, a larger amphitheater at 48m.

ⁱJean-Claude Golvin. *L'Amphitheatre Romain: Essai sur la Theorsation de sa Forme et de ses Fonctions*. Trans. Caeli Smith. (Diffusion de Bocard, Paris, 1988), p. 157-224.

ⁱⁱIbid.

ⁱⁱⁱIbid.

^{iv}Giovanni Uggeri. "Fidenae." *Brill's New Pauly*. Ed. Hubert Cancik and Helmuth Schneider. Brill Online. 2015. <http://referenceworks.brillonline.com/entries/brill-s-new-pauly/fidenae-e411400?s.num=7> (21 Jan 2015).

-
- ^vTacitus. *Annales* 4.62 in Tacitus. *Tacitus: Annals Book I-IV*. Comp. R.H. Martin and A.J. Woodman. Trans. Rebecca Napolitano. (Cambridge University Press, New York, 2006).
- ^{vi}Jean-Claude Golvin. *L'Amphitheatre Romain: Essai sur la Theorsation de sa Forme et de ses Fonctions*. Trans. Caeli Smith. (Diffusion de Boccard, Paris, 1988), pl. 53.
- ^{vii}Ibid.
- ^{viii}Ibid.
- ^{ix}Ibid.
- ^xTacitus. *Annales* 4.62 in Tacitus. *Tacitus: Annals Book I-IV*. Comp. R.H. Martin and A.J. Woodman. Trans. Rebecca Napolitano. (Cambridge University Press, New York, 2006).
- ^{xi}Party Vision, "Carnival Booth Options." 2015. < <http://www.partyvision.com/entertainment-events-rentals/carnival-booth-options/> > (27 Feb 2015).
- ^{xii}Tacitus. *Annales* 4.62 in Tacitus. *Tacitus: Annals Book I-IV*. Comp. R.H. Martin and A.J. Woodman. Trans. Rebecca Napolitano. (Cambridge University Press, New York, 2006).
- ^{xiii}Jean-Claude Golvin. *L'Amphitheatre Romain: Essai sur la Theorsation de sa Forme et de ses Fonctions*. Trans. Caeli Smith. (Diffusion de Boccard, Paris, 1988).
- ^{xiv}Hen-Magonza, "Trajan's Column." Flickr. 2012. <https://www.flickr.com/photos/hen-magonza/7161296699/> (3 March 2015).
- ^{xv}Frank Lepper and Sheppard Frere. *Trajan's Column*. (Alan Sutton Publishing, Inc., New Hampshire, 1988), p. 152.
- ^{xvi}Tacitus. *Annales* 4.62 in Tacitus. *Tacitus: Annals Book I-IV*. Comp. R.H. Martin and A.J. Woodman. Trans. Rebecca Napolitano. (Cambridge University Press, New York, 2006).
- ^{xvii}Jean-Claude Golvin. *L'Amphitheatre Romain: Essai sur la Theorsation de sa Forme et de ses Fonctions*. Trans. Caeli Smith. (Diffusion de Boccard, Paris, 1988), p. 287.
- ^{xviii}Jean-Claude Golvin. *L'Amphitheatre Romain: Essai sur la Theorsation de sa Forme et de ses Fonctions*. Trans. Caeli Smith. (Diffusion de Boccard, Paris, 1988), pl. 33.
- ^{xix}Rod Pierce. "Perimeter of Ellipse." *Math is Fun*. Ed. Rod Pierce. 10 Nov 2014. <http://www.mathsisfun.com/geometry/ellipse-perimeter.html> (22 Jan 2015).
- ^{xx}Keith Still. "Static Crowd Density (General)." *Crowd Safety and Crowd Risk Analysis*. 2014. <http://www.gkstill.com/Support/crowd-density/CrowdDensity-1.html> (10 Feb 2015).
- ^{xxi}Jean-Claude Golvin. *L'Amphitheatre Romain: Essai sur la Theorsation de sa Forme et de ses Fonctions*. Trans. Caeli Smith. (Diffusion de Boccard, Paris, 1988), p. 287.
- ^{xxii}Jean-Claude Golvin. *L'Amphitheatre Romain: Essai sur la Theorsation de sa Forme et de ses Fonctions*. Trans. Caeli Smith. (Diffusion de Boccard, Paris, 1988), pl. 33.
- ^{xxiii}Ibid.
- ^{xxiv}Ibid.

CHAPTER 3: “WHAT DID THIS LOOK LIKE?”

With the three-dimensional shell of the structure determined, understanding the framework of this amphitheater and the support system follows. In the construction of modern bleachers it is common to see the seats installed in sections or risers for the purpose of decreasing the number of necessary vertical supports. It is reasonable to suggest that a similar fashion of construction was utilized by the Romans and that sections of seats were supported by single vertical piles. The number of vertical supports and their surface area are directly correlated with the weight of the load they need to bear.

FRAMEWORK AND SUPPORTS

In order to understand the framework that this structure would require, seed numbers will have to be set for the number of columns as well as the surface area of the columns themselves. With these seed values for cross-sectional areas and amount of piles per section determined, it will be possible to calculate what the necessary vertical support would be from each pile, as well as what the allowable load for each pile would be. If the allowable load is smaller than the calculated value for the necessary vertical support, then the seed values need to be revisited and corrected. Again, the amphitheater at Verona will be utilized as *comparanda* and therefore the amphitheater at Fidenae will be estimated to have 75 radial support units as at Verona.ⁱ The purposes of calculation, a wedge, one-seventy-fifth of the amphitheater, will be utilized in order to calculate the necessary supports. The following designations will be used to denote each section of the structure (Figure 3.1)

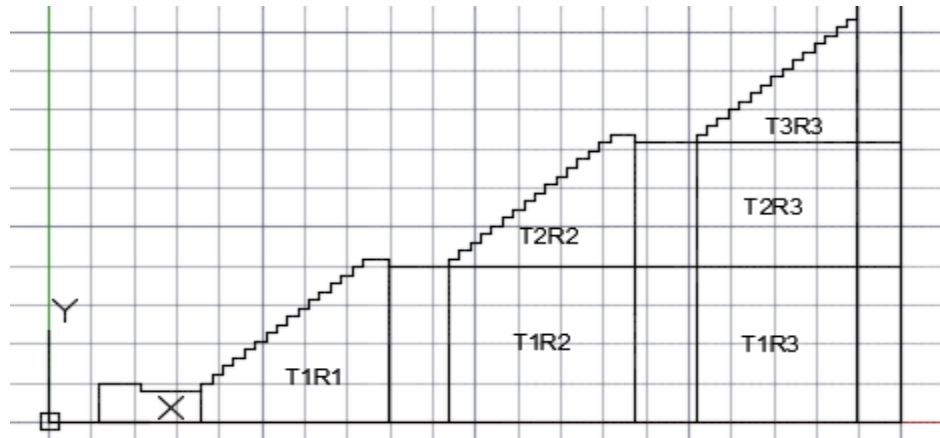

Figure 3.1 Amphitheatrical Nomenclature

On the first tier of the amphitheater, comprised of sections T1R1, T1R2, and T1R3, the seed value for the cross-sectional areas has been determined to be 10”×10” piles. These seed values were set through the use of Cornell’s Capacity of Wood Column calculator.ⁱⁱ This calculator allows for the input of the modulus of elasticity as well as the value for force of compression parallel to the grain in addition to other variables such as unbraced height and column size. The estimated weight of each section was then determined and the column size which corresponded to a capacity at least more than that of the estimated weight were selected as seed values. Section T1R1 will be said to have 4 vertical supports distributed evenly while T1R2 and T1R3 have 8 each. The values of 4 and 8 were chosen as those numbers allow for even spacing between supports if a support is always set at the innermost and outermost seats of each section. The fact that the number of supports in T1R2 and T1R3 are greater than the number in T1R1 is due to the fact that the first two will be holding a greater amount of weight since as the radius of the cross-section increases, the arc length which is supported by each set of radial framework lengthens, thereby accruing a larger load. The seed value for the cross-sectional areas of T2R2, T2R3, and T3R3 has been determined to be 8” ×8” piles and was done so in a similar fashion to the 10”×10” piles aboveⁱⁱⁱ. The practice of reducing the cross-sectional areas of the

piles as the height of the structure increases is due to the fact that these sets of framework would have smaller loads to support. In addition this is in accordance with Vitruvius' recommendation to have the structure mimic the trees in the way that as the tree grows and becomes smaller and thinner at the top, so too should structures.^{iv}

The allowable load for each pile will vary due to the fact that the length of the pile, which is a determining factor, itself will vary; in addition, the necessary vertical supporting force will vary due to the fact that each pile is supporting a different weight which varies with the radius of the amphitheater. The total allowable stress for each pile can be determined using the formula provided by the *National Design Specification* (NDS) which is as follows:

$$\sigma_{Allowable} = F_c \left\{ \frac{1 + \frac{F_{CE}}{F_c}}{2c} - \sqrt{\left[\frac{1 + \frac{F_{CE}}{F_c}}{2c} \right]^2 - \frac{F_{CE}}{c}} \right\} \quad \text{Eq. (3.1)}$$

Where: $\sigma_{Allowable}$ =Allowable stress (psi)

F_c =Allowable stress for compression parallel to the grain (lb)

F_{CE} =Reduced Euler buckling stress (lb)

E =Modulus of Elasticity (psi)

$c=0.8$ For sawn lumber.

Within this equation the F_{CE} values can be found through the following equation for reduced Euler buckling stress:

$$F_{CE} = \frac{K_{CE}E}{\left(\frac{KL}{d}\right)^2} \quad \text{Eq. (3.2)}$$

Where $K_{CE}=0.30$ for visually graded lumber

$K=0.7$ for Fixed-Pinned Support

L =Height of the column (in)

d =Finished dimension of the cross-section (in).

The value that this equation calculates however is the allowable stress. In order to convert this to a value which can be compared to the amount of force necessary to support the weight, the allowable stress should be multiplied by the cross-sectional area of the pile as follows:

$$A\sigma_{Allowable} = P_{Allowable} \quad \text{Eq. (3.3)}$$

Where A=Cross-sectional area of the pile (in²)

P_{Allowable}=Allowable load (lb)

To find the necessary vertical support to compare to the allowable value, the equations for the deflection of the following two scenarios can be set equal and solved for P.^v

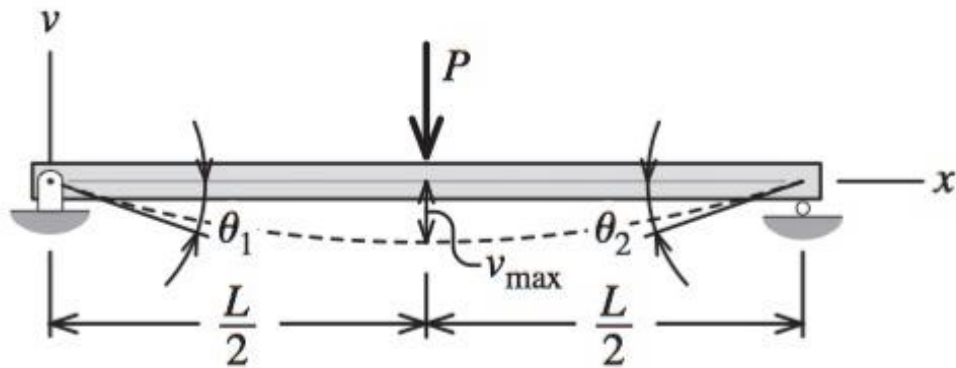

Figure 3.2 Deflection of Simply Supported Beam Due to Point Load

Where $v_{\max} = \frac{-PL^3}{48EI}$ Eq. (3.4)

v_{\max} =Maximum Deflection

P=Point load

L=Length of the beam

E=Modulus of Elasticity

I=Moment of Inertia

This calculation allows the necessary vertical support that each column would have to provide, P, in order to keep the respective section of the amphitheater from deflecting to be calculated. In

order to determine exactly how much deflection this vertical support would need to counteract, the following deflection of a simply supported beam due to a distributed load can be set equal to Eq 3.4 above.

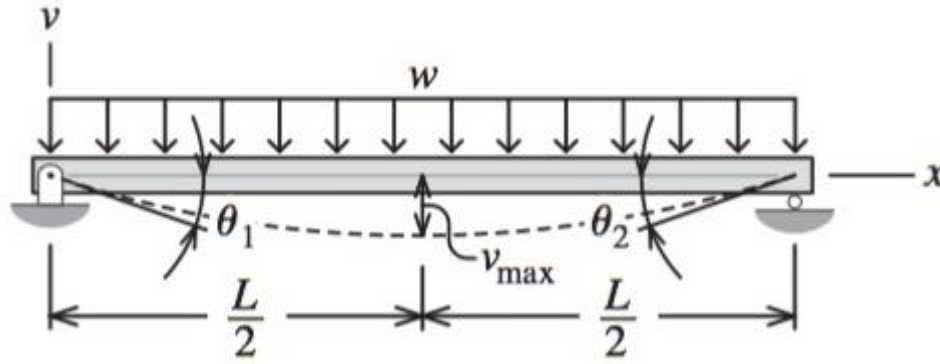

Figure 3.3 Deflection of Simply Supported Beam Due to Distributed Load

Where $v_{max} = \frac{-5wL^4}{384EI}$ Eq. (3.5)

w =Distributed Load

Eq. 3.5 determines how much deflection the weight of the materials and the people will cause to a section of the amphitheater. In designing this amphitheater, it is desired that the deflection due to the vertical support be equal to the deflection due to the distributed load. Setting the two deflection calculations, Eq 3.4 and 3.5, equal to each other and solving for P, the result is as follows:

$$P = 0.625wL \quad \text{Eq. (3.6)}$$

In this equation the distributed load, w , is the weight of the wood and the weight of the people divided by the length of the beam for one-seventy-fifth of the amphitheater, recall that to facilitate calculations only a one-seventy-fifth wedged portion of the amphitheater is being considered.

$$P=0.625(W_w+W_p) \quad \text{Eq. (3.7)}$$

Where W_w =Weight of the wood (lb)

W_p =Weight of people (lb)

In order to calculate the total weight of the people in attendance, the seating capacity can be multiplied by the weight of an average Roman. Intending to overestimate rather than underestimate, the weight of a Roman soldier, 145lb, will be utilized.^{vi} The weight of people which each pile would have to support would not simply be the weight of the people in one wedge section divided by the number of piles; this is determined by equating a ratio of the weight of people in the section to the weight of the people in the entire wedge with the area of each section to the area of the entire wedge.

$$\frac{W_{Px}}{\frac{W_P}{75}} = \frac{A_x}{A_W} \quad \text{Eq. (3.8)}$$

Where W_{Px} =Weight of the people in the section

W_p =Weight of people in the entire amphitheater

A_x =Area of the section in question

A_w =Area of the wedge

In order to determine the weight of the wood, a discussion concerning the most probable material for the construction of the amphitheater is imperative. There is no description of the type of wood in the construction of the amphitheater at Fidenae in either Tacitus or Suetonius. Every type of material will have its own distinct properties which in turn will affect the allowable loads as well as the weight of the framework. In his work, *Ten Books on Architecture*, Vitruvius provides a comprehensive guide which delineates the most common types of Roman wood with their uses and material properties. In searching for a material which is conducive for wood working yet strong enough to support a large load, the most probable types are oak, elm,

poplar, cypress, and fir which Vitruvius (Vit. *De Architectura* 2.9) claims are most suitable for buildings.^{vii} Out of these possibilities, fir seems the most probable due to the fact that Vitruvius describes it as a light weight material and one that is not easily bent under stress. The specific type of fir tree to be considered is the *abies alba*, or the Silver fir, which is distributed over the whole of Europe.

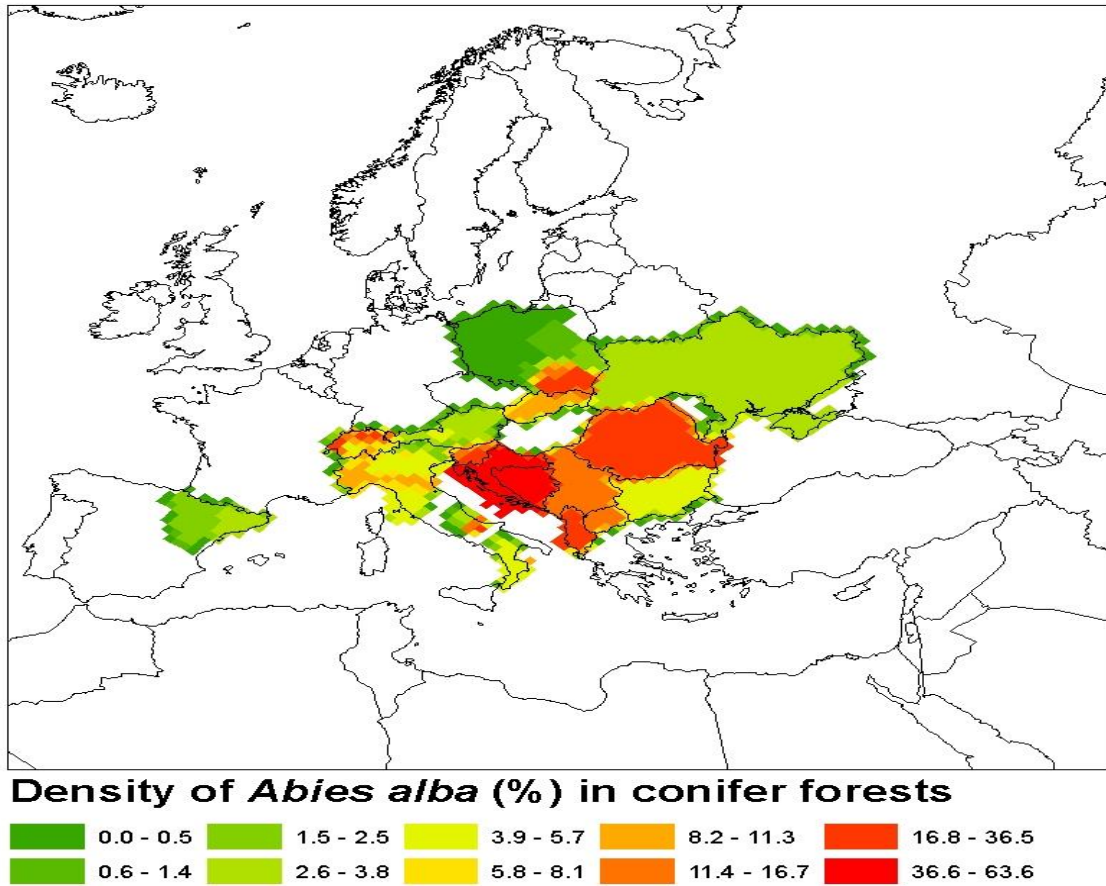

Figure 3.4 Density of *Abies Alba* in Europe

This tree is said to have a straight trunk which is beneficial in the making of timber piles and supports, as well as the average height of the *abies alba* is roughly 40m which would allow for large structural elements; the density is 441kg/m³.

Now that the most probable material for the structure has been decided upon, the weight of each section can be determined. The weight of each section is related to the weight of the entire wedge in the same way that the weight of the spectators was above.

$$\frac{W_{Wx}}{\frac{W_W}{75}} = \frac{A_x}{A_W} \quad \text{Eq. (3.9)}$$

Where W_{wx} =Weight of the wood in the section

W_w =Weight of wood in the entire amphitheater

In order to determine the weight of the wood contributing to a load on these supports in the entire amphitheater the wood making up the bottoms and backs of the seats as well as the risers need to be accounted for.

$$W_W = \rho\{(A_{Bottom} + A_{Back})t + V_R\} \quad \text{Eq. (3.10)}$$

Where ρ = Density of the wood ($\frac{lb}{in^3}$)

A_{Bottom} = Surface area of the seat bottoms (in^2)

A_{Back} = Surface area of the seat backs (in^2)

t =Thickness of the wood (3.937in)

V_R =Volume of wood for the riser (in^3)

The wood making up the seat bottoms has a cross sectional area of 0.53m×0.1m (20.87in×3.937in) while the wood making up the seat backs has a cross sectional area of 0.63m×0.1m (24.80in×3.937in). These values were taken from the amphitheater at Verona due to the fact that this amphitheater has been determined previously to be quality comparanda. However the surface area of the seat bottoms and seat backs varies with the length, which in turn varies with the radius of the amphitheater. In order to calculate the surface area of the seat bottoms, it can be seen that this surface area would be equal to the surface area of an elliptic ring

with an outer radius of the extremes of the amphitheater and the inner radius of the arena dimensions. The area of this shape is as follows.

$$A_{Bottom} = \frac{\pi}{4}(AB - ab) \quad \text{Eq. (3.11)}$$

Where: A=Major Axis of the Entire Amphitheater (m)

B=Minor Axis of the Entire Amphitheater (m)

a=Major Axis of the Arena (m)

b=Minor Axis of the Arena (m).

The calculations for the area of the seat backs cannot be simplified in the same manner however. If the circumference is taken at every seat back and multiplied by the height of the seat backs, 0.53m, then the surface area of the elliptic ring can be determined and is as follows.

$$A_{Backs} = C(0.53m) \quad \text{Eq. (3.12)}$$

Where

$$C = 2\pi \sqrt{\frac{\left(\frac{A}{2}\right)^2 + \left(\frac{B}{2}\right)^2}{2}} \quad \text{Eq. (3.13)}$$

However in order to find the area of the seat backs, the circumference needs to be taken incrementally at the position of each seat. Since each seat is 0.53m wide, subtracting twice that amount, since there are seats on both sides of the amphitheater, from the dimensions of the overall arena yields the dimensions of the ellipse at the top most seat. If n times twice the dimensions of the seat back is subtracted from the dimensions and the sum of all the circumferences is taken from 0 to 44, that would represent the sum of the circumferences of each seat back in the amphitheater.

$$C_T = \sum_{n=0}^{44} 2\pi \sqrt{\frac{\left(\frac{A-2n(.53m)}{2}\right)^2 + \left(\frac{B-2n(.53m)}{2}\right)^2}{2}} \quad \text{Eq. (3.14)}$$

Where n = Number of the column, with zero being the outer most and 44 being the innermost.

However that formula would not be considering the fact that there are walkways and dividers in the amphitheater as well. In order to account for these, Eq. 3.14 has been incremented as follow where the values of 3.55m, 1.5m, and 2m represents the walk ways, dividers and back walls respectively.

$$C_T = \sum_{n=0}^{14} 2\pi \sqrt{\frac{\left(\frac{A-2n(.53m)}{2}\right)^2 + \left(\frac{B-2n(.53m)}{2}\right)^2}{2}} + 3.55m + 1.5m + 2m + \sum_{n=15}^{29} 2\pi \sqrt{\frac{\left(\frac{A-2n(.53m)}{2}\right)^2 + \left(\frac{B-2n(.53m)}{2}\right)^2}{2}} + 3.55m + 1.5m + \sum_{n=30}^{44} 2\pi \sqrt{\frac{\left(\frac{A-2n(.53m)}{2}\right)^2 + \left(\frac{B-2n(.53m)}{2}\right)^2}{2}} \quad \text{Eq. (3.15)}$$

This value can then be multiplied by the dimension of the seat width, 0.53m, in order to get the total area of the seat backs in the amphitheater. By substituting Eqs. 3.11 and 3.15 into Eq. 3.10 the result is the formula which would yield the total weight of the wood in the amphitheater.

$$W_W = \rho \left\{ \left(\frac{\pi}{4} (AB - ab) + \sum_{n=0}^{14} 2\pi \sqrt{\frac{\left(\frac{A-2n(.53m)}{2}\right)^2 + \left(\frac{B-2n(.53m)}{2}\right)^2}{2}} + 3.55m + 1.5m + 2m + \sum_{n=15}^{29} 2\pi \sqrt{\frac{\left(\frac{A-2n(.53m)}{2}\right)^2 + \left(\frac{B-2n(.53m)}{2}\right)^2}{2}} + 3.55m + 1.5m + \sum_{n=30}^{44} 2\pi \sqrt{\frac{\left(\frac{A-2n(.53m)}{2}\right)^2 + \left(\frac{B-2n(.53m)}{2}\right)^2}{2}} \right) t + V_R \right\}$$

Eq. (3.16)

Now that this has been established, the forces necessary to support each section of T1R1, T2R2, and T3R3 can be determined and compared to the allowable values. For exact values see Appendix A.

Sections T1R2 and T2R3 are dependent on how much the framework for T2R2 and T3R3 weigh respectively; while T1R3 is dependent on not only the weight from T3R3, but also T2R3. In addition cross supports have been placed on each of the frameworks of T2R2, T2R3, and T3R3 in order to guard against any lateral motion of the amphitheater that the crowd might cause. These cross supports can be seen in the figure below which represents 1/75 of the amphitheater.



Figure 3.5: Cross-Sectional View of Segment of the Amphitheater at Fidenae

The total weight of section T2R2 can be found as described in Appendix B. As can be seen in Figure 3.5 above, the heights of each vertical post will vary with the radius, thereby varying the lengths of the cross supports; as well as the length of the horizontal supports will vary with the radius of the amphitheater. Once the weight of each section has been calculated the allowable values of load that each vertical support can bear can be calculated. As can be seen in Appendix A, all of the necessary support forces are less than the allowable loads and therefore the seed values are correct.

After affirming these seed values, the cross sectional view of the amphitheater would be as follows with four vertical supports necessary in T1R1 and 8 in all other regions. The supports in each section are evenly spaced and as can be seen in Figure 3.6 below, are vertically aligned with the tiers above and below.



Figure 3.6 Cross-Sectional View of the Amphitheater at Fidenae

THREE DIMENSIONAL DESIGN AND MODEL

As far as exterior design of the amphitheater at Fidenae, the wooden amphitheater found on Trajan's column depicted earlier serves as the main guide. ^{viii}



Figure 3.7: Wooden Amphitheater on Trajan's Column.



Figure 3.8: Zoomed-View of Triangular Supports on Wooden Amphitheater

As can be seen in figure 3.8 above, the second tier consists of a system of triangular supports. This system of supports can be seen in the on the exterior of the amphitheater at Fidenae, depicted in Figure 3.9 below, on the second and third tiers.

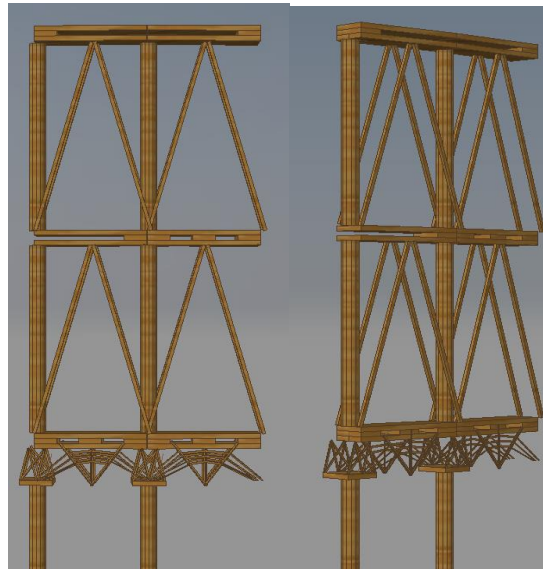

Figure 3.9: View of Edifice of the Amphitheater

Tier 1 of the wooden amphitheater on Trajan's column consists of arched entry ways; however this segment of the design was completed in stone. With the common style of amphitheaters being arched entryways, it was desired that the design of the model for the amphitheater at Fidenae incorporate arches. Therefore wood constructions of arches were sought as the model for Tier 1. Trajan's bridge, also depicted on Trajan's column, consists of wooden arches and the arch design from this bridge has been implemented on Tier 1 of the amphitheater at Fidenae.^{ix}



Figure 3.10: Trajan's Bridge on Trajan's Column

Figure 3.11: Zoomed-View of Triangular Supports on Trajan's Bridge

As can be seen above, at the base of each arch are two triangular supports, from which the arch segments emanate. This has been replicated on Tier 1 of the amphitheater at Fidenae as can be seen in Figure 3.12 below.

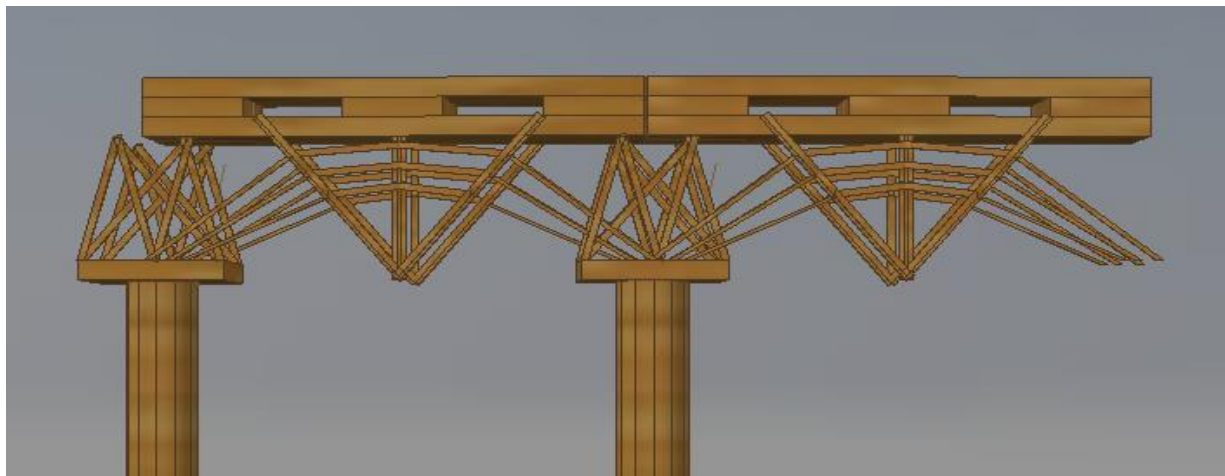

Figure 3.12: Details of Tier 1 Edifice and Triangular Supports

Up to this point, the design of the amphitheater has been determined and discussed piecemeal; now, the full three-dimensional model of the amphitheater can be generated. The amphitheater at Fidenae prior to its collapse in 27 AD would most probably have looked at follows.

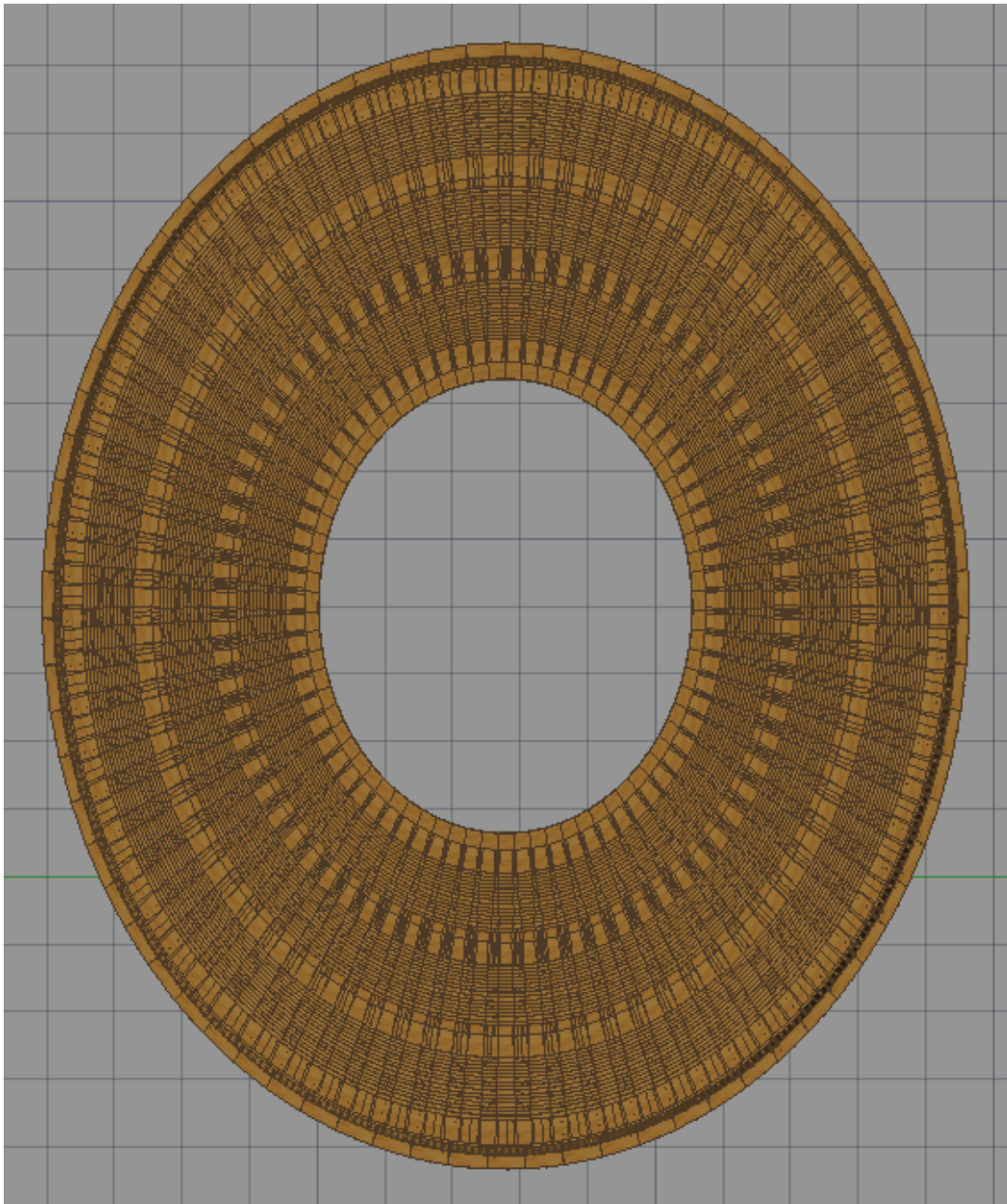

Figure 3.13 Top View of Amphitheater at Fidenae

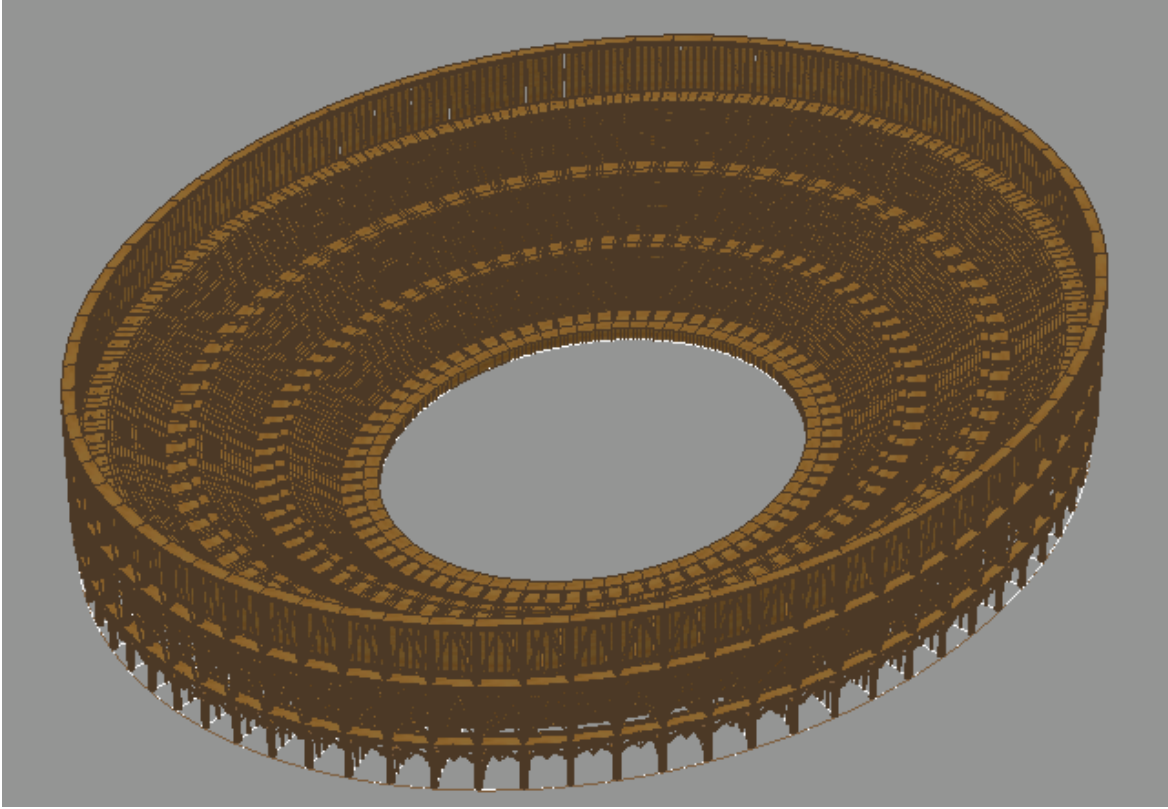

Figure 3.14 Aerial View of Amphitheater at Fidenae

There is something to be said for the method which has been utilized to this point for reconstructing the most probable model of the amphitheater at Fidenae, that “most probable” is just what it is. In the highly speculative field which is conjecturing what ancient structures might have looked like, there is no certainty and one just has to follow the data until it runs out and educated and executive decisions must ensue. The literature, art, and archaeological data were pursued to their respective ends and executive decisions were made in the final design process as to how exactly to fit the pieces together. The results are as can be seen above and give room for further interpretation, questioning, and research. In addition, a video of the amphitheater can be found by means of the following link:

<https://www.youtube.com/watch?v=2tMl7BLiu4s>

ⁱ Jean-Claude Golvin. *L'Amphitheatre Romain: Essai sur la Theorsation de sa Forme et de ses Fonctions*. Trans. Caeli Smith. (Diffusion de Boccard, Paris, 1988), pl. 33.

ⁱⁱ John Ochsorn. "Capacity of Wood Column Calculator," Cornell University, 2014. <https://courses.cit.cornell.edu/arch264/calculators/example7.1/index.html> (20 Feb 2015).

ⁱⁱⁱ Ibid.

^{iv} Vitruvius. *De Architectura* 2.9. Vitruvius. *Vitruvius: Ten Books on Architecture*. Comp. and Trans. Ingrid D. Rowland and Thomas Noble Howe. (Cambridge University Press, New York, 1999.)

^v Timothy Philpot. *Mechanics of Materials: An Integrated Learning System*. Ed. 3. (Wiley, New Jersey, 2012), p. 854.

^{vi} Jonathan Roth. *The Logistics of the Roman Army at War: 264 B.C. –A.D. 235*.(Brill, Leiden, 1999),p. 9.

^{vii} Vitruvius. *De Architectura* 2.9. Vitruvius. *Vitruvius: Ten Books on Architecture*. Comp. and Trans. Ingrid D. Rowland and Thomas Noble Howe. (Cambridge University Press, New York, 1999.)

^{viii} Hen-Magonza, "Trajan's Column."Flickr. 2012. <https://www.flickr.com/photos/hen-magonza/7161296699/> (3 March 2015).

^{ix} Anjali Mehrotra and Branko Glisic. "Reconstruction of the appearance and structural system of Trajan's Bridge" *Journal of Cultural Heritage*. 16, (2014).

CHAPTER 4: “WHAT DID ATILIUS DO SO WRONG?”

Now that the entirety of the amphitheater’s superstructure has been determined, the design of the foundation can begin to be understood. One of the senate’s main qualms (Tac. *Ann.* 4.63) with the amphitheater at Fidenae was that it was not placed “on ground of tested solidity” (*neve amphitheatrum imponeretur nisi solo firmitatis spectatae.*)ⁱ Divergent types of soil could have supported the amphitheater at Fidenae differently and therefore what the typology of the soil in the area of Fidenae must be discussed first and foremost.

TOPOGRAPHICAL OVERVIEW AND SOIL PROFILE OF FIDENAE

Fidenae, five or six miles outside of Rome and would have been a part of the Campagna, or undulating plain, in which Rome is also situated.ⁱⁱ This plain would have been volcanic in origin and bountiful with tufa rock due to the stratification of volcanic remains during the age that the Campagna was covered by the sea.ⁱⁱⁱ The hills on the banks of the Tiber as well as the stratum which permeates the subterranean structure of the entire region consist mainly of this volcanic tufa rock.^{iv} The region in which Fidenae would have existed falls within section 56.1 of the soil profile map in Figure 4.1 below. ^v

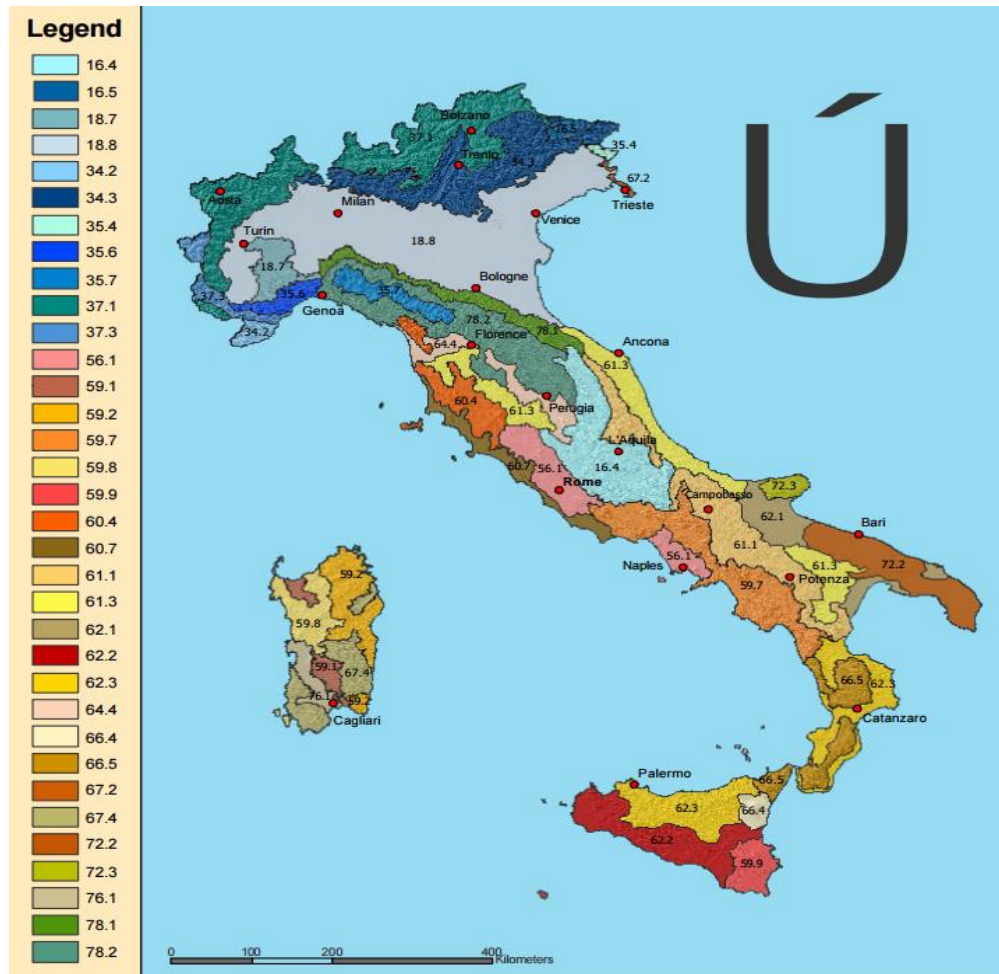

Figure 4.1 Soil Map of Italy

Section 56.1 in Figure 4.1 consists of soils which can be characterized as derived from volcanic materials, as bountiful with clay and iron oxides, as alluvial, as well as soils of anthropic terraces.^{vi} Each of these soils has very divergent mechanical properties and therefore more specific data concerning localized soil profiles are necessary. If data from the European Soil Portal—Soil Data and Information Systems is imported into ArcGIS, the soil polygon, which would have most likely corresponded with Fidenae based upon Platner and Sir William Gill’s references, can be found. From the texture layer it can be seen that the soil is >65% sand and <18% clay with the depth of the rock to be 80-120cm below ground level.^{vii} This corresponds

with what Platner has suggested with the layer of tufa permeating the substructure of the soil of Campagna.^{viii} How much support would this type of soil have provided to the structure? In order to calculate the maximum compression force of the soil, a penetrometer reading of comparable soil was taken. As aforementioned, GIS data placed the soil at Fidenae to have >65% sand and <18% clay. On the guide for textural classification put forth by the USDA Soil Survey Manual which can be seen in Figure 4.2 below, soil of this typology is classified as sandy loam.

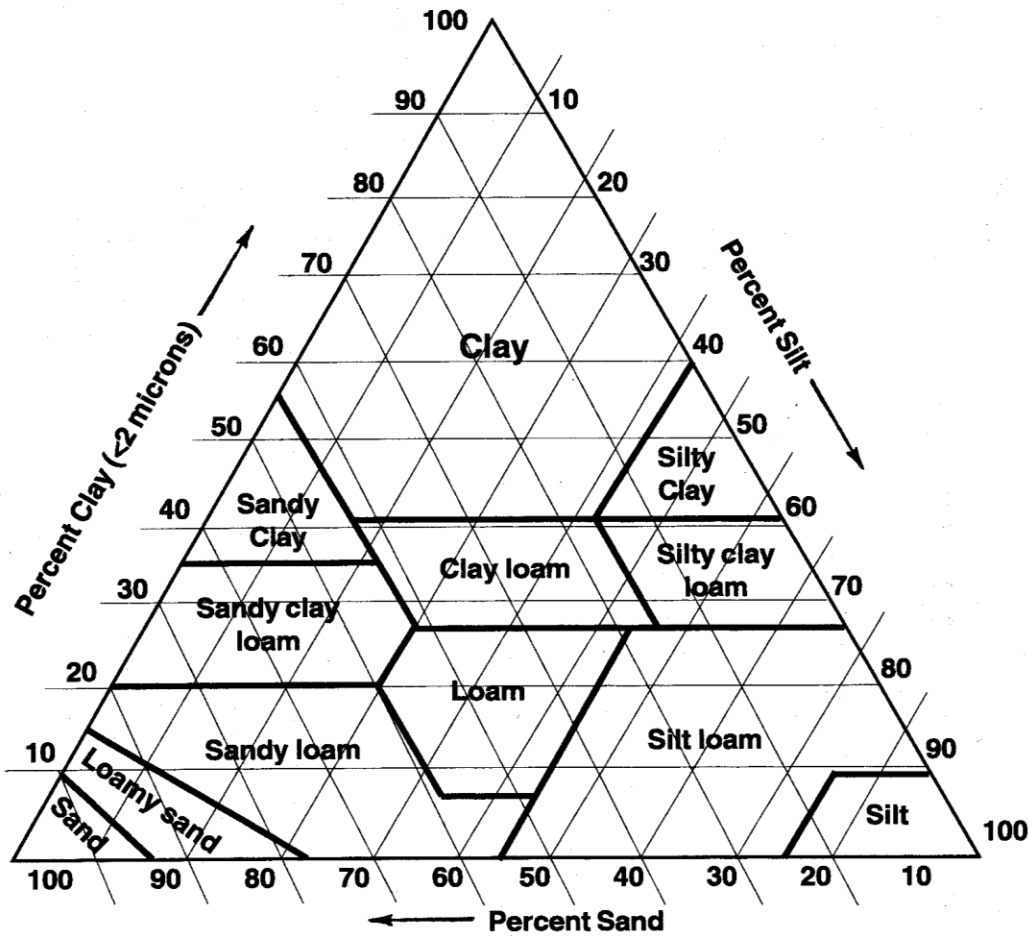

Figure 4.2 Soil Textural Triangle^{ix}

An area of sandy loam soil was tested using a penetrometer and found to have an average maximum compression value of 28.39 ± 4 psi.

ARCHAEOLOGICAL COMMENTS ON AMPHITHEATER AT FIDENAE

It is not known by means of archaeological evidence or definitive primary literature the precise location of the amphitheater within the region of Fidenae. Lorenzo Quilici and Stefania Quilici Gigli in their archaeological survey of Fidenae suggest that the site of the abandoned quarries, the hillside just north of Villa Spada, would have easily facilitated the needs associated with constructing an amphitheater.^x However they go further as to suggest that possibly the subterranean structure, cavernous due to the mining of the tufa, may have precipitated the disaster.^{xi} This hypothesis is problematic due to the fact that in order for bifurcation, which as aforementioned Tacitus' narrative so strongly suggests, to have occurred, the structure would have needed to be built in the *a structure creuse* style. With this style in mind, the hillsides which referenced in the survey of Fidenae would not have been necessary. In addition, the hypothesis suggests that the cavernous rock the amphitheater foundations could have been placed on would have caused the collapse. Rather, this paper rather hypothesizes that it was not *what* Atilius put the foundations on that caused the problem. In accordance with Tacitus' description (Tac. *Ann.* 4.62), this paper, on the premise that Atilius "did not place the foundation under the structure through to solid ground" (*neque fundamenta per solidum subdidit*),^{xii} postulates that the foundations of the amphitheater at Fidenae never made it to the rock layer 120cm down.

ANALYSIS OF FOUNDATIONS

The manner in which the superstructure of this amphitheater would have been grounded into its foundation would have most likely been through pile foundations. Roger Ulrich presents piling as a main type of Roman timber foundation in his book *Roman Woodworking*.^{xiii} He

asserts that vertical beams, which he claims were usually left round, were pounded into the ground to which subsequently the framework of a structure could be attached.^{xiv} Pile foundations are especially necessary where the load of the superstructure needs to be translated to the bedrock^{xv}. In the case of the amphitheater at Fidenae the main piles, or the outermost vertical supports associated with the edifice of the amphitheater would have been the most important to stabilize the amphitheater and should have been laid to the bedrock. In contrast to this recommendation, as suggested in Chapter 1 *per solidum*^{xvi} is most likely alluding to the fact that the original trenches were *not* dug to the point where they reached a stable base. According to literary evidence such as Vitruvius this would have been in disagreement with common practice where foundations were encouraged to be due to the point of bedrock or highly compacted soil. This sentiment can be seen in the two Vitruvian excerpts below (Vit. *De Architectura* 1.5).

Tunc turrium murorumque fundamenta sic sunt facienda, uti fodiantur, si queat inveniri, ad solidum et in solido, quantum ex amplitudine operis pro ratione videatur.

The next thing to do is to lay the foundations for the towers and the walls. Dig down to solid bottom, if it can be found, and lay them therein, going as deep as the magnitude of the proposed work seems to require.^{xvii}

And Vitruvius also states (Vit. *De Architectura*. 1.3):

Firmitatis erit habita ratio, cum fuerit fundamentorum ad solidum depression, quaque e materia, copiarum sine avarita diligens electio.

Durability will be assured when foundations are carried down to the solid ground and materials are wisely and liberally selected.^{xviii}

As discussed in Chapter 1, Tactius' preposition choice as compared with that of Vitruvius may carry structural implications. The use of *per solidum* meaning "through to solid ground," instead of *ad solidum* meaning "to solid ground," can suggest that perhaps the type of soil Atilius chose to build on was not the problem, instead the depth he was willing to dig for the foundation was

too shallow. Atilius, the man associated with the building of this amphitheater is said by Tacitus to be doing so with not the most commendable of motivations. Tacitus claims (Tac. *Ann.* 4.62) that Atilius “was the kind of man who undertook the work neither with an abundance of money, nor with the ambition of someone aspiring to make a name for themselves by public service. Rather he undertook that work for sordid reward” (*ut qui non abundantia pecuniae nec municipali ambitione sed in sordidam mercedem id negotium quaesivisset.*)^{xxix} Therefore in order to build this amphitheater in a cheap and quick fashion, it is a possibility that the vertical supports were not dug through to the bedrock.

In the determination of the radius of the piles for the reconstruction of the amphitheater at Fidenae, piles of 0.7m radius were selected in order to bear the load associated with the superstructure. This agrees with the fact that *abies alba* trees have been found to grow up to 1.5m in diameter.^{xxx} Timber pile capacity cannot exceed 270kN,^{xxxi} and in order to calculate this capacity for the amphitheater at Fidenae, the weight of the timber framework as well as well as the weight of the people associated with each pile need to be determined. The values for material will vary with each tier as well as with each row; results can be found in Appendix C. As can also be seen in Appendix C, the load expected from the materials comprising the superstructure as well as the people does not exceed the 270kN limit.

Even within the realm of timber piles there are different categories to be considered: point bearing piles, friction piles, and compaction piles. Due to the fact that the depth of rock is 80-120cm from ground level, point bearing piles seem to be the most reasonable.^{xxii} Point bearing piles are utilized when rock is located at a reasonable depth from the surface. As established prior by GIS, the rock layer was 120cm below the surface^{xxiii}; however as aforementioned Atilius did not go down deep enough to reach this rock layer (solid ground).^{xxiv}

Therefore point bearing piles would have been logical, but through primary literary evidence, this type of pile can be ruled out. Friction piles are utilized when there is no layer of rock at a reasonable depth, or occur when piles are not dug down to said stratum.^{xxv} With primary literary evidence, these seem to be the most probable type of piles Atilius would have been laying here.

The most probable depth these piles would have been laid has been discussed in the terms that they would not have been to the bedrock 120cm below; however how deep would they have to have been laid in order to sustain the superstructure of the amphitheater itself and yet collapse under the onerous weight of people in attendance? In order to calculate this, consider the following two-dimensional representation of the back pile of the amphitheater.

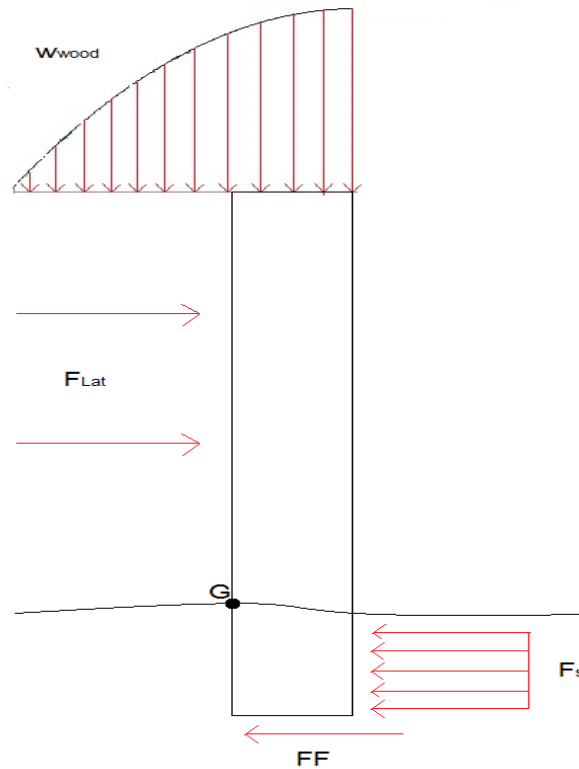

Figure 4.3 FBD Outermost Pile without Load from People: This is a simplified drawing which does not include the seats, walkways, and stairs which the load is also acting upon to the left of the pile.

In Figure 4.3 above, the dead distributed load of the materials can be seen a top the pile creating a positive moment about point G. The magnitude of the dead distributed load was found by plotting the loads supported by each vertical support, as found in Appendix C, divided by the radial width of material they were each supporting versus the distance of each vertical pile center from the innermost support. That graph can be seen below along with the line of best fit calculated through the series of data points.

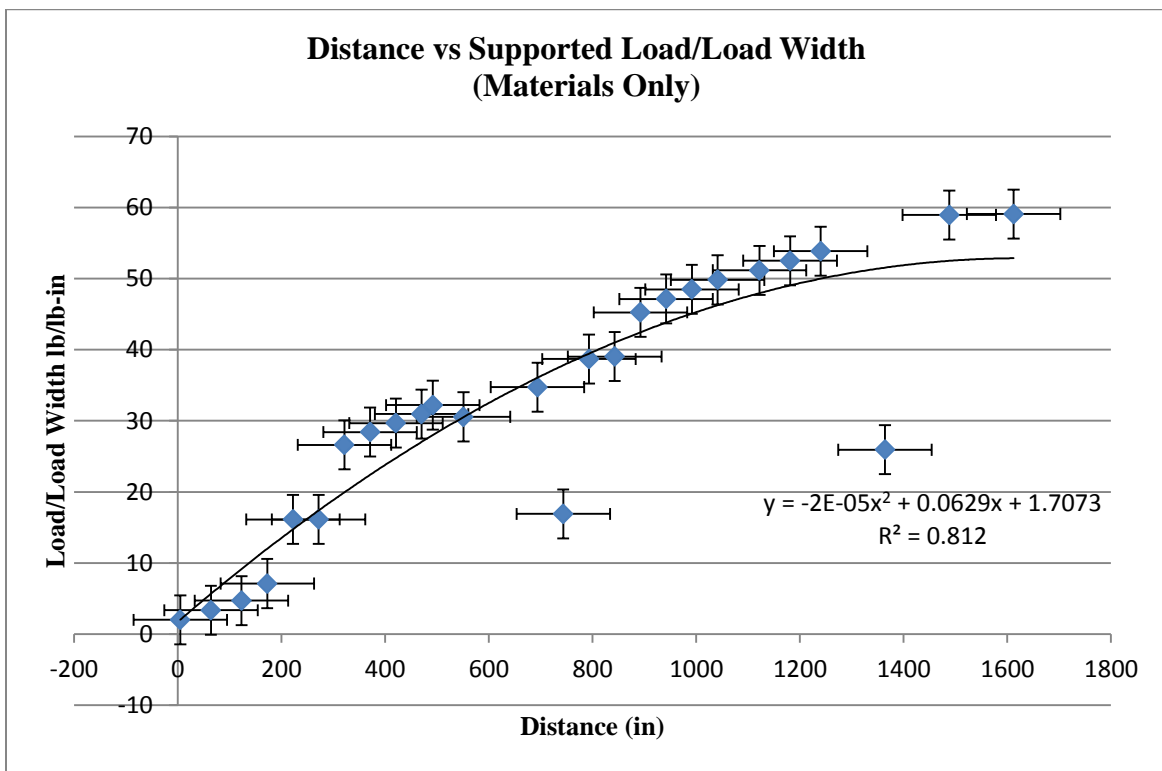

Figure 4.4: Graph of Distance versus Supported Load/ Load Width (Materials)

In order to calculate the distributed dead load of the wood, the integral of the line of best fit found in Figure 4.4 above can be taken between two distances: the lower limit is defined as the distance of the inner pile to the front of the load the pile is supporting, whereas the upper limit is

defined as the distance of the inner pile to the back of the back pile, or back of the load the pile is supporting. This integral can be seen below.

$$\int_{Df}^{Db} w_{wood} dx = \int_{1568}^{1612} (-2 \times 10^{-5} x^2 + 0.0629x + 1.7073) dx \quad \text{Eq. 4.1}$$

Where Df=Distance from the inner pile to the front of the load the pile is supporting (in)

Db=Distance from the inner pile to the back of the load the pile is supporting (in)

w_{wood}=Dead load of materials (lb)

The moment created by the dead load of the materials can be calculated by multiplying the integral of the load calculated in Eq. 4.1, with units of pounds, by the centroid of that dead load, with units of inches, leaving the result as a moment in pound-inches. In turn, the centroid can be found by raising the integrand in Eq. 4.1 by an additional power of x, and then dividing that result by the area of the distributed load. The result is as follows.

$$M_G = \left(\int_{Df}^{Db} w_{wood} dx \right) \frac{\left(\int_{Df}^{Db} w_{wood} x dx \right)}{\int_{Df}^{Db} w_{wood} dx} \quad \text{Eq. 4.2}$$

Where M=Moment about a point created by the dead load of wood. (lb-in)

Furthermore, it can be seen that Eq. 4.2 reduces to Eq. 4.3 when the integral of the load itself drops out from the term.

$$M_G = \left(\int_{Df}^{Db} w_{wood} x dx \right) \quad \text{Eq. 4.3}$$

Again considering Figure 4.3 above, another force contributing to the equation for the pile's stability, or moment about G, is the force of the soil itself. The soil can be seen laterally supporting the pile from the right side creating a negative moment about point G. The maximum

value that the soil is able to exert in compression was found as follows. The value given by the penetrometer, $28.39 \pm 4 \text{ psi}^2$, is in units of force per area and in order to convert this to a force, the equation for the lateral area of the pile should be multiplied to it.

$$F_S = 28.39LA \quad \text{Eq. 4.4}$$

Where F_S = Lateral Compression Force of the Soil (lb)

LA=Lateral Area of the Pile (in^2)

The lateral area of the half of the pile impacted by the force of this soil from the right can be found by multiplying the depth of the pile by half of the circumference as follows below.

$$LA = \frac{2\pi r}{2} d \quad \text{Eq. 4.5}$$

Where r =radius of the pile (in)

d =depth of the pile (in).

If Eq. 4.5 is substituted back into Eq. 4.4 then the following equation is the result.

$$F_S = 28.39 \frac{2\pi r}{2} d \quad \text{Eq. 4.6}$$

The units of distributed load however are force per distance and therefore Eq. 4.6 is divided by the depth of the pile as is illustrated below in order to attain the value for distributed load.

$$w_s = \frac{F_S}{d} = \frac{28.39 \frac{2\pi r}{2} d}{d} = 28.39 \frac{2\pi r}{2} \quad \text{Eq. 4.7}$$

With the value for the distributed load created by the soil established, the moment which this creates about point G can be determined. Similar to the argument for Eq. 4.2, the integral of the distributed load, or in this case, the area created by the depth of the pile and the force, can be multiplied by its centroid, in this case simply half the depth, in order to determine the moment about point G as is shown below in Eq. 4.8.

$$M_G = w_s d \frac{d}{2} \quad \text{Eq. 4.8}$$

The final equation for determining the moment about point G caused by the soil can be found by substituting Eq. 4.4 into Eq. 4.5.

$$M_G = (8.39\pi r) d \frac{d}{2} \quad \text{Eq. 4.9}$$

Another force presented in Figure 4.3 is the force of friction on the pile. The force of friction is equal to the normal force of the pile multiplied by the coefficient of friction of volcanic ash soil, respectively these values are the force of weight of the materials and 0.57.^{xxvi}

$$FF = \mu F_n = 0.57 F_w \quad \text{Eq. 4.10}$$

Where FF=Force of Friction (lb)

μ =Coefficient of Friction

F_w=Force of Weight (lb)

Due to the fact that the force of friction was treated as a point force at the bottom of the pile rather than as distributed load in accompaniment with the lateral force presented by the soil the moment it creates about G can be found by multiplying the force by the moment arm which in this case is the depth of the pile. This equation can be seen as follows.

$$M_G = FFd \quad \text{Eq. 4.11}$$

By substituting Eq. 4.8 into 4.9 the following equation for the moment created about point G due to the frictional force of the soil is created.

$$M_G = 0.57 F_w d \quad \text{Eq. 4.12}$$

The final forces illustrated in Figure 4.3 are the lateral forces which help to counter the moment created about point G due to the dead load. These lateral supports run on Tiers 1 and 2 on their respective vertical midpoints and have been calculated for the for the maximum compression values which *abies alba* can support in compression.

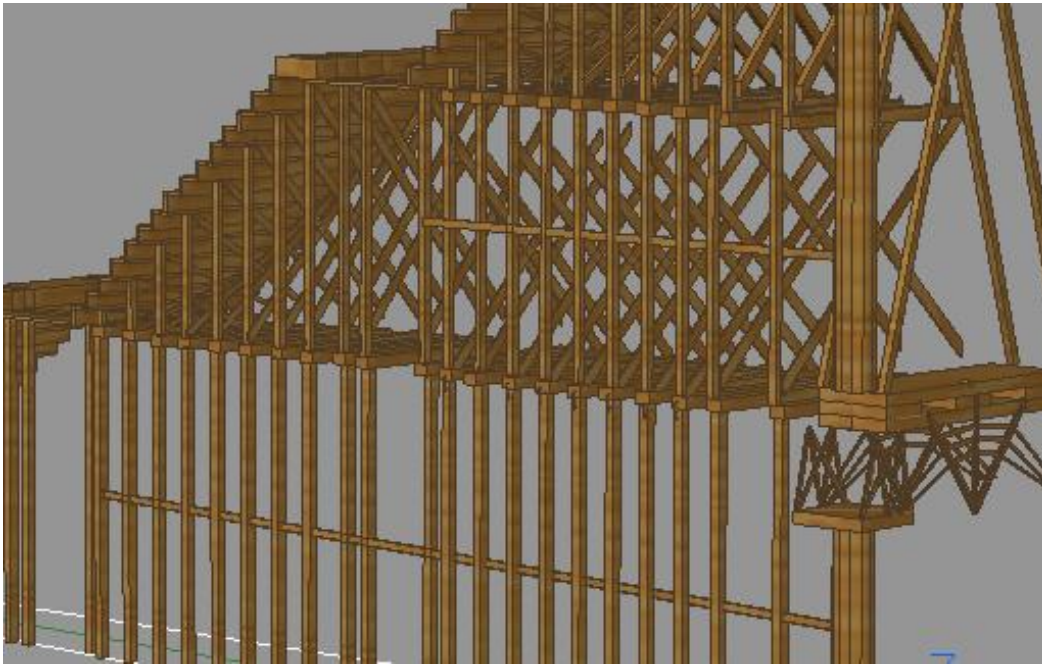

Figure 4.5 Lateral Supports

Like the frictional force, these are point forces instead of distributed loads; therefore they can be multiplied by their respective moment arms in order to calculate the moments they create about point G. Due to the fact that the lateral support has been assumed to be equal in each of these since the maximum values were utilized, the equation for the moment about point G can be seen as follows.

$$M_G = F_{Lat}(d_1 + d_2) \quad \text{Eq. 4.13}$$

Where F_{Lat} =Maximum Lateral Support Force (lb)

d_1 = Moment Arm of F_{Lat} on Tier 1, or Height of Lateral Support on Tier 1 (in)

d_2 = Moment Arm of F_{Lat} on Tier 2, or Height of Lateral Support on Tier 2 (in).

Now that each of the moments created by the forces and loads in Figure 4.3 has been discussed and determined, the sum of the moments (Eq. 4.3, 4.7, 4.10, 4.11) about point G can be set to zero and the necessary depth can be found. The equation is as follows and the positive sign convention for the moments is counterclockwise.

$$\sum M_G = 0 = \left(\int_{D_f}^{D_b} w_{wood} x dx \right) - (28.39\pi r) d \frac{d}{2} - 0.57Fwd - F_{Lat}(d_1 + d_2) \quad \text{Eq. 4.14}$$

From Eq. 4. 14 the necessary pile depth can be calculated and found to be 82cm±5 which is indeed less than the 120cm depth to bedrock; therefore this is consistent with Tacitus' account that the foundation was not laid "through to solid ground" (*per solidum.*) This proves that Atilius could have laid the pile anywhere between 82cm and just shy of 120cm and it would have been stable without the live load of people. However this amphitheater was not built for the sole purpose of aesthetics; ergo subsequently the load of spectators shall be accounted for.

Much like in the process delineated above for calculating depth without people, consider a free-body diagram of the edificial pile as is given below.

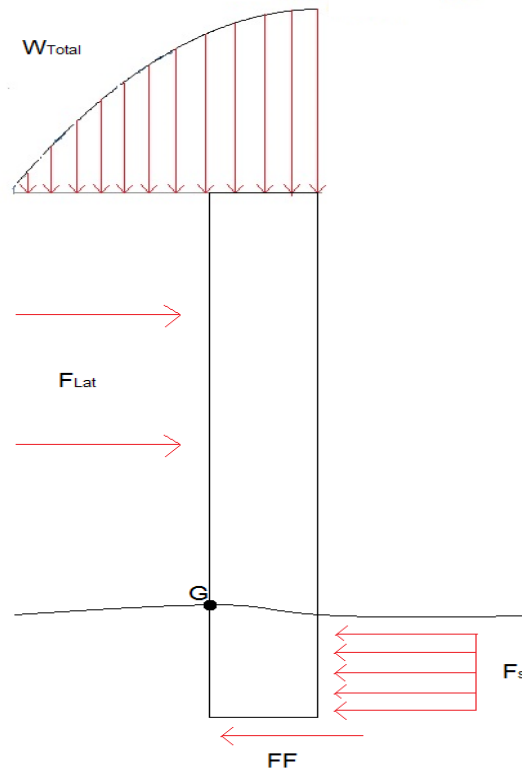

Figure 4.6 FBD Outermost Pile with Load from People: This is a simplified drawing which does not include the seats, walkways, and stairs which the load is also acting upon to the left of the pile.

The only difference from Figure 4.3 to 4.6 is the additional distributed load from the people added atop the pile. In Figure 4.6 above, the distributed load of the spectators can be seen atop the pile creating a positive moment about point G. The magnitude of the total distributed load was found by plotting the total loads due to the people and materials supported by each vertical support, as found in Appendix C, divided by the radial width of material they were each supporting versus the distance of each vertical support center from the innermost support. That graph can be seen below along with the line of best fit calculated through the series of data points.

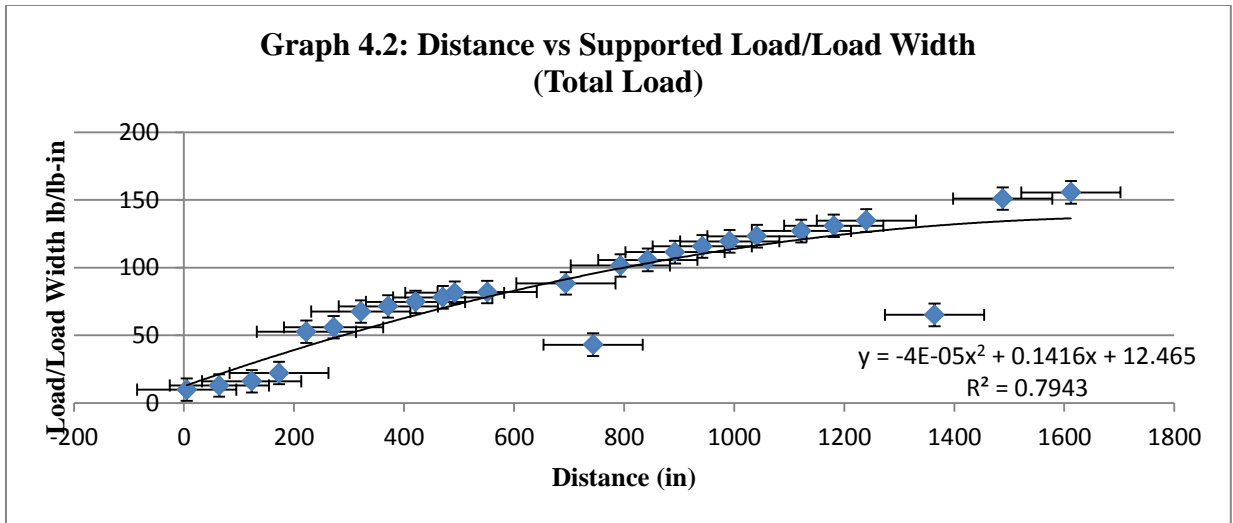

Figure 4.7 Graph of Distance versus Supported Load/ Load Width (Total Load)

In order to calculate the total distributed load, the integral of the line of best fit found in Figure 4.6 above can be found in the same manner Eq. 4.1 was and the resulting integral can be seen below.

$$\int_{Df}^{Db} w_{Total} dx = \int_{1568}^{1612} (-4 \times 10^{-5} x^2 + 0.1416x + 12.465) dx \quad \text{Eq. 4.15}$$

Where Df=Distance from the inner pile to the front of the load the pile is supporting (in)

Db=Distance from the inner pile to the back of the load the pile is supporting (in)

w_{wood} =Dead load of materials and people (lb)

The moment created by the load of the materials and people can be calculated in the same way Eq. 4.2 was and the result is as follows.

$$M_G = \left(\int_{Df}^{Db} w_{Total} dx \right) \frac{\left(\int_{Df}^{Db} w_{Total} x dx \right)}{\int_{Df}^{Db} w_{Total} dx} \quad \text{Eq. 4.16}$$

Where M=Moment about a point created by the dead load of wood. (lb-in)

Again, it can be seen that Eq. 4.16 reduces to Eq. 4.17 when the integral of the load itself drops out from the term.

$$M_G = \left(\int_{D_f}^{D_b} w_{Total} x dx \right) \quad \text{Eq. 4.17}$$

If the first term, representing Eq. 3 is removed from Eq. 4.14, and Eq. 4.17 is inserted instead, the following equation representing the moment about G due to the people, materials, and various other counteracting forces previously discussed can be found.

$$M_G = 0 = \left(\int_{D_f}^{D_b} w_{Total} x dx \right) - (28.39\pi r) d \frac{d}{2} - 0.57 F w d - F_{Lat} (d_1 + d_2) \quad \text{Eq. 4.18}$$

From Eq. 4.18 the necessary pile depth can be calculated and found to be 191cm±5 which is indeed greater than the 120cm depth to bedrock which it has been decided Atilius did not dig down to/through. This proves that the structure was not built in a manner which would have supported the amount of people calculated in Ch. 2—collapse is imminent. The details concerning this amphitheater’s demise shall be elucidated in the coming pages through detailed discussion concerning the joints and how they would have been affected by the erroneously laid foundations.

JOINT STRESS ANALYSIS

Thus far, only one of Tacitus’ two reasons for the collapse was examined. In addition to claiming that the foundations led to the downfall of the amphitheater, Tacitus (*Tac. Ann.* 4.62) also asserts that Atilius did not “build the wooden framework with strong joints” (*neque firmis nexibus ligneam compagem superstruxit.*)^{xxvii} This amphitheater, similar to any structure, is a complex system with many joints; therefore which joints would Tacitus have been referring is a difficult question to consider. It was discussed in depth previously that the overabundance of

people would have caused a moment on the edificial pile which the supporting forces could not counter. As this pile started to rotate, it would have exceeded the stress values it was engineered for and therefore the joints which make up the edificial pile should be closely examined. For the purposes of the rest of this discussion, the following nomenclature has been applied to the joints.



Figure 4.8: Joint Nomenclature

For Joint 1, the notching connection between the pile and the first horizontal beam will be discussed. A section, approximately the same diameter as the vertical pile, could have been cut out of the horizontal beam; the vertical support would have been inserted snugly in the cavity as can be seen in Figure 4.9 below.



Figure 4.9 Joint 1

As the pile commenced its turns inward, due to the reasons discussed previously, a force of weight as a function of the angle from the vertical would have started to create a bending moment on the pile. This can be illustrated in the free body diagram in Figure 4.10 below.

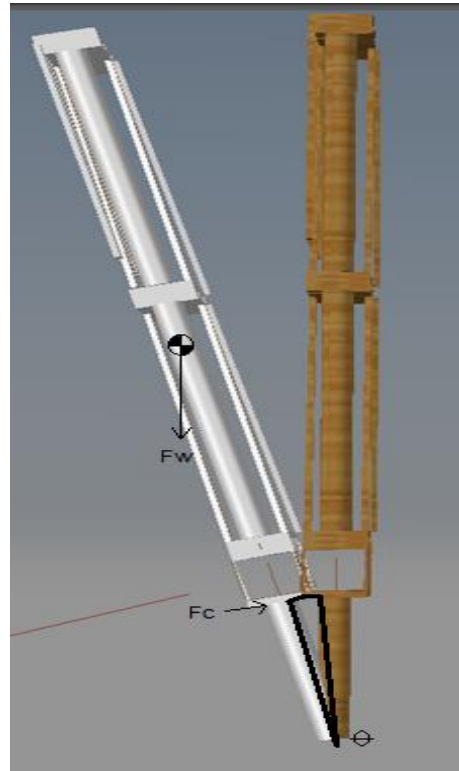

Figure 4.10 FBD Joints 1, 4-7: Side View

It can be noted that the support forces of the soil and lateral bracings have not been included; this is due to the fact that at the point where the pile starts to move, those supports have been overcome and therefore their impact on the system is substantially weakened and can be ignored.

Three stresses, which should be considered based upon the free body diagram in Figure 4.10 above, are axial stress, bending stress, and shear stress. Axial stress can be found by dividing an axial load by the cross sectional area which the axial load is normal to; the general equation is as follows.

$$\sigma_A = \frac{F}{A} \quad \text{Eq. 4.19}$$

Where σ_A = Axial stress exerted on a member along the longitudinal axis (psi)

F = Axial Force, or a load directed along the longitudinal axis (lb)

A = Cross sectional area of the load-bearing plane, created when the member is cut by a transverse plane in order to determine internal effects; this is orthogonal to the longitudinal axis (in²)^{xxviii}

In the case of the free body diagram in Figure 4.10, the only axial force is the horizontal component of the load caused by the materials and the people. The components of the weight can be illustrated Figure 4.11 below.



Figure 4.11 Components of Weight: Side View

The cross sectional area normal to the horizontal component of the weight is that of the cylindrical pile. The axial stress formula for the pile can be found as follows.

$$\sigma_A = -\frac{F_W \cos \theta}{A} \quad \text{Eq. 4.20}$$

Where F_W = Force of Weight Due to Materials and People (lb)

θ = Angle of Rotation as Measured in Figure 4.11.

This is not the only stress acting on an element in this pile however. A bending moment, which acts about the vertical axis, produces normal stresses which in turn acts perpendicular to the surface of the pile. This moment can be multiplied by the distance from the element in question to the neutral axis of the pile and subsequently divided by the moment of inertia about the vertical axis as the following equation illustrates.

$$\sigma_B = \frac{My}{I} \quad \text{Eq. 4.21}$$

Where σ_B = Bending stress (psi)

M = Bending moment that acts about the neutral axis (lb-in)

y = Perpendicular distance to the neutral axis (in)

I = Moment of Inertia about the neutral axis (in^4)^{xxix}

Seeking the maximum bending stress, the maximum value for y or the radius of the pile, will be utilized. The forces perpendicular to the surface of the pile include the vertical component of the load induced by materials and people, as can be seen in Figure 4.11, as well as the compressional force which can be attributed to the surrounding material of the notch, as can be seen in Figure 4.10.

$$\sigma_B = \frac{y}{I} (-F_W \sin \theta d_1 + F_C d_2) \quad \text{Eq. 4.22}$$

Where F_C = Compressional Force (lb).

The compressional force is a normal force and therefore is equal and opposite to the force it is countering. In this instance, as can be seen in Figure 4.10, the force it would be countering is the vertical component of the weight up to the maximum compressive value of 6525psi.^{xxx} The maximum stress incurred by the load can be found by the following formula.

$$\sigma_{Max} = (F_w LA) \quad \text{Eq. 4.23}$$

Again, Eq. 4.5 can be utilized to find the lateral area of the portion of the cylinder in the notch, and the maximum stress incurred due to the load can be found to be 143±psi in compression. Therefore since the desired normal force due to the load does not exceed the allowable value, the compressional force can be set equal to the vertical component of the weight. These forces can be multiplied by their respective moment arms, and the following equation for the bending stress of this pile ensues.

$$\sigma_B = \frac{y}{I} (-F_w \sin\theta d_1 + F_w \sin\theta d_2) \quad \text{Eq. 4.24}$$

Where d_1 =Moment arm of Vertical Component of Weight (in)

d_2 =Moment arm of F_C (in.)

Eq. 4.24 can be added to Eq. 4.20 in order to calculate the total maximum stress on an element within the pile as is illustrated below.

$$\sigma_C = \frac{y}{I} (-F_w \sin\theta d_1 + F_w \sin\theta d_2) - \frac{F_w \cos\theta}{A} \quad \text{Eq. 4.25}$$

Where σ_C = Combined Stress (psi).

In order to calculate where this equation will exceed the allowable compressional stress value of -6525 psi, Eq. 4.25 can be graphed along with the equation $y=-6525\text{psi}$. The result is as follows.

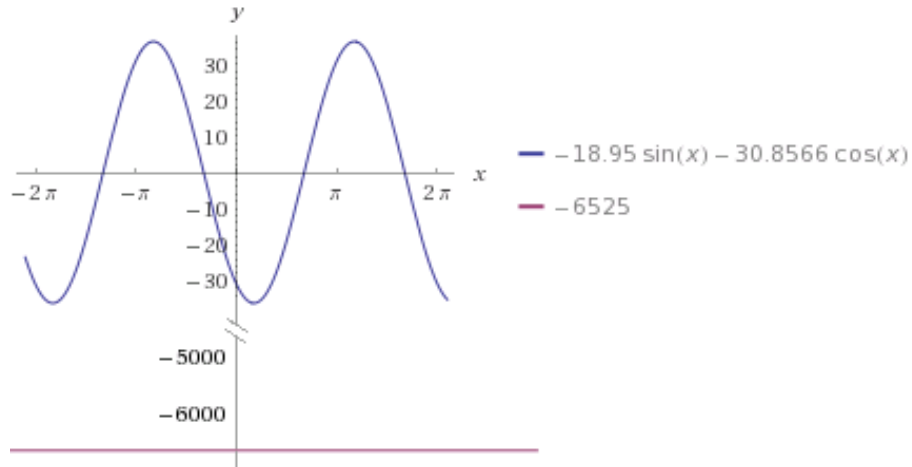

Figure 4.12 Joint 1 Stress Graphical Solution: The x-axis is measured in the angle measured from the vertical in radians; the y-axis represents the stress in psi.

The line corresponding to Eq. 4.25 never intersects with the line corresponding to the allowable stress which means that this joint remains stable despite the motion of the pile.

The last type of stress to consider at Joint 1 is shear stress which is defined as a product of shear force and the first moment of area which is then divided by the product of the moment of inertia and the thickness of the specimen as can be illustrated by Eq. 4.26 below.

$$\tau = \frac{VQ}{It} \quad \text{Eq. 4.26}$$

Where V=Shear Force (lb)

Q=First Moment of Area (in³)

I=Moment of Inertia (in⁴)

t=Thickness of Specimen (in).^{xxxi}

In this instance, the two shear forces are due to the vertical component of the load, due to materials and people, as well as the maximum compressive normal force incurred by the pile in the notch. With these values, Eq. 4.26 can be altered and is as follows.

$$\tau = \frac{Q}{It} (F_w \sin\theta + F_C) \quad \text{Eq. 4.27}$$

Again, as can be seen in Figure 4.10, the force the compressive force will be countering is the vertical component of the weight up to its maximum value of 6525psi^{xxxii} and as established previously, the vertical component of the weight does not exceed the maximum allowable stress and therefore the compressive force can be replaced by the equation for the vertical component of weight as follows.

$$\tau = \frac{Q}{It} (2F_w \sin\theta) \quad \text{Eq. 4.28}$$

Once the needed value for shear stress has been calculated, it can be compared to the allowable shear stress for *abies alba* which is 1100psi.^{xxxiii} The value for shear stress is maximized when the $\sin\theta$ is 1. Due to the fact that the maximized required shear stress, 90.0±4psi, is less than that of the allowable value, the joint remains uncompromised during the fall. Joints 4-7 can be analyzed in a similar fashion since they are virtually identical to Joint 1. The only difference is that as the height of the joint increases, the weight incurred by the joint decreases. Since axial stress, bending stress, and shear stress are all directly correlated to the force of weight, these too decrease and therefore Joints 4-7 can be said to be stable during the fall.

For the second joint, the connection between the triangular supports and the horizontal beam will be discussed. Again a cavity, or in this case a system of eight cavities, is the most likely option for this joint as can be seen below.



Figure 4.13 Joint 2

Again as the structure turn inwards, the force of weight creates axial, bending, and shear stresses on each member. The same approach employed in Joint 1 will be utilized; therefore consider Figure 4.14, a free body diagram of one of the eight members making up the triangular support.



Figure 4.14 FBD Joint 2: Side View

The formula to calculate axial stress on Joint 2 is the same as Eq. 4.25 except for the fact that since there are eight 6”×6” vertical supports to bear the load, only one-eighth of the load will be considered for each of the supports. The result from graphing Eq. 4.25 with the appropriate values as well as the line $y=-6525$ psi is as follows.

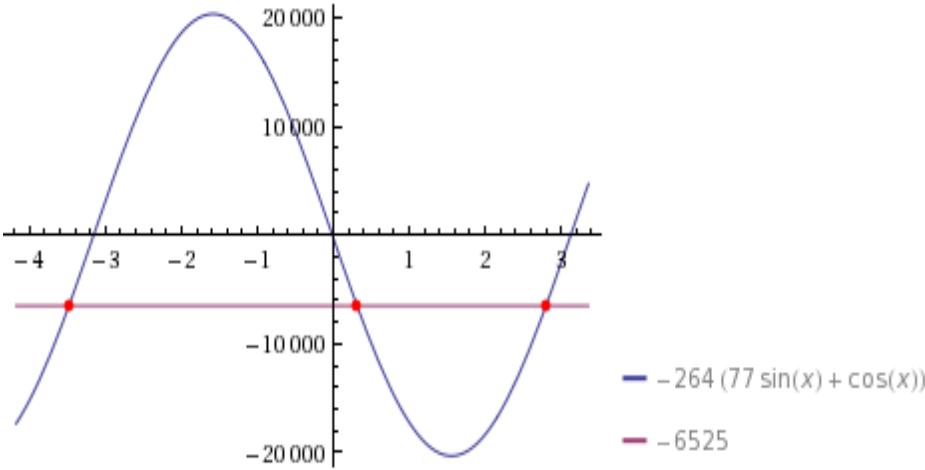

Figure 4.15 Joint 2 Stress Graphical Solution: The x-axis is the angle measured from the vertical in radians; the y-axis represents stress measured in psi.

The first value where Eq 4.25 intersects the line $y=-6525$ psi represents where Joint 2 will fail and is at 0.314rad or 18.0°. Joint 3 must be examined to see if it fails before this angle; if it does not then Joint 2 is where the bifurcation Tacitus described most probably occurred and the pile will collapse in the way illustrated in Figure 4.16.



4.16 Joint 2 Failure: This is a side view and to the left is the inside of the amphitheater.

The maximum shear stress incurred at Joint 2 can be calculated by Eq. 4.26, and found to be, 729 ± 12 psi, which is less than the allowable shear stress for *abies alba*, 1100psi; therefore Joint 2 does not fail due to shear stress.

The last joint to be considered is Joint 3 which is the connection between the triangular supports and the horizontal beam. It should be noted that this will be considered as a single horizontal beam—a simplification of the reality of three layers of beams. It will be assumed that these beams are well jointed with metal fasteners or at least by flax or hemp twine.^{xxxiv} Joint 3 is not simply the horizontal conglomerate balancing on the vertices of the triangular supports however. Small wood sections are inserted into the crux of the triangles' vertices and the beam is laid on top as follows in Figure 4.17.

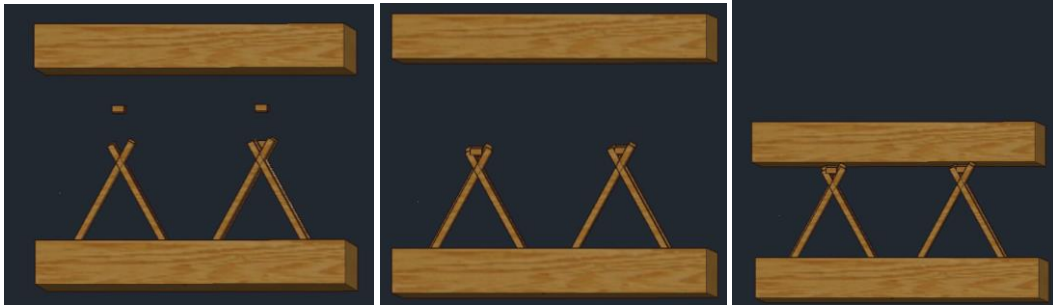

Figure 4.17 Joint 3: This is a front view of the joint as would be seen from the outside of the amphitheater. The connection between the small wood pieces and the horizontal conglomerate would have been some type of metal fastening such as nails, while the connection between the small wood section and the triangular supports would have relied on friction. To understand at what point in the rotation the frictional support will fail, consider the following free body diagram in Figure 4.18.



Figure 4.18 FBD Joint 3: This is a side view of the pile, focusing on the forces on Joint 3.

From Figure 4.18 the equation of motion of the forces perpendicular to the pile can be written as follows in Eq. 4.29 where the two frictional supports are countered by the vertical component of the total load.

$$\sum F_x = 0 = -2FF + F_w \sin\theta \quad \text{Eq. 4.29}$$

Where FF= Frictional Force (lb).

The frictional force in this instance would be equal to the product of coefficient of friction^{xxxv} and the weight incurred by the joint at that point which can be seen in the following equation.^{xxxvi}

$$FF = \mu F_w \quad \text{Eq. 4.30}$$

If Eq. 4.30 is substituted into Eq. 4.29, and the force of weight is broken into its product of mass and acceleration of gravity, the following equation can be found.

$$\sum F_x = 0 = -2\mu mg + Mgsin\theta \quad \text{Eq. 4.31}$$

Where m=Mass of the structure not including the triangular supports (lb)

M=Mass of the structure including the triangular supports (lb.)

If Eq. 4.31 is solved for θ , it can be found that the frictional support fails at 41.3° . This is greater than the 18.0° angle of failure calculated prior; therefore it can be established that Joint 2 is the most probable joint that Tacitus is referring to as precipitating the collapse due to the fact that it is the first to break at 18.0° .

The collapse was not one isolated joint however; this was an entire amphitheater that collapsed killing over of 30,000 people. It is highly probable that more than one of the piles driven into the soil would have incurred a load too large to counter as discussed prior; however all it would have taken to start the demise of the amphitheater is one. Each pile attached to this initiator of motion would have incurred dynamic loads beyond what they had been designed for. As it has been illustrated in depth above, they were not even designed well enough for the people

on top of them, let alone for any type of motion that might sway the structure. Therefore even if one of the sections had collapsed, the connected sections would have been pulled in as well leading to a cascade failure, the deaths of over 30,000 people, and the collapse of the amphitheater at Fidenae.

ⁱTacitus. *Annales*. 4.63. in Tacitus. *Tacitus: Annals Book I-IV*. Comp. R.H. Martin and A.J. Woodman. Trans. Rebecca Napolitano. (Cambridge University Press, New York, 2006).

ⁱⁱ William Gell, Sir. *The Topography of Rome and Its Vicinity*, (Harrison and Co., London, 1846), p.248-249.

ⁱⁱⁱSamuel Ball Platner. *The Topography and Monuments of Ancient Rome*, (Norwood Press, Boston, 1911), p. 12.

^{iv}Samuel Ball Platner. *The Topography and Monuments of Ancient Rome*, (Norwood Press, Boston, 1911), p. 19.

^vEdoardo A. Costantini, Ferdinando Urbano, and Giovanni L'Abate, "Soil Regions of Italy" *Centro Nazionale Cartografia Pedologica*, 2004, http://soilmaps.entecra.it/download/csi-BrochureSR_a4.pdf (17 March 2015).

^{vi} Ibid.

^{vii} Beverly Chomiak (private communication).

^{viii}Samuel Ball Platner. *The Topography and Monuments of Ancient Rome*, (Norwood Press, Boston, 1911), p. 19.

^{ix}United States Department of Agriculture. "Soil Texture Triangle" *Natural Resources Conservation Service Soils*, 1996, http://www.nrcs.usda.gov/wps/portal/nrcs/detail/soils/survey/?cid=nrcs142p2_054167 (19 March 2015).

^x Lorenzo Quilici and Stefania Quilici Gigli. *Fidenae*, (Consiglio Nazionale delle Ricerche, Rome, 1986).

^{xi} Ibid.

^{xii}Tacitus. *Annales*. 4.62. in Tacitus. *Tacitus: Annals Book I-IV*. Comp. R.H. Martin and A.J. Woodman. Trans. Rebecca Napolitano. (Cambridge University Press, New York, 2006).

^{xiii} Roger B. Ulrich. *Roman Woodworking*, (Yale University Press, New Haven, 2007), p 73.

^{xiv} Ibid.

^{xv} Braja M. Das. *Principles of Geotechnical Engineering*, Ed. 7, (Cengage Learning, Stamford, 2010), p. 576.

^{xvi}Tacitus. *Tacitus: Annals Book I-IV*. Comp. R.H. Martin and A.J. Woodman. Trans. Rebecca Napolitano. (Cambridge University Press, New York, 2006).

^{xvii} Vitruvius. *De Architectura* 1.5. in Vitruvius: *Ten Books on Architecture*. Comp. and Trans. Ingrid D. Rowland and Thomas Noble Howe. (Cambridge University Press, New York, 1999.)

^{xviii}Vitruvius. *De Architectura* 1.3. in Vitruvius: *Ten Books on Architecture*. Comp. and Trans. Ingrid D. Rowland and Thomas Noble Howe. (Cambridge University Press, New York, 1999.)

^{xix}Tacitus. *Ann*. 4.62. in Tacitus. *Tacitus: Annals Book I-IV*. Comp. R.H. Martin and A.J. Woodman. Trans. Rebecca Napolitano. (Cambridge University Press, New York, 2006).

-
- ^{xx}Eric Meier. "European Silver Fir," *The Wood Database*, 2014, <http://www.wood-database.com/lumber-identification/softwoods/european-silver-fir/> (20 March 2015).
- ^{xxi}Braja M. Das. *Principles of Geotechnical Engineering*, Ed. 1, (Brooks/Cole Engineering Division, California, 1984), p 338.
- ^{xxii}Braja M. Das. *Principles of Geotechnical Engineering*, Ed. 1, (Brooks/Cole Engineering Division, California, 1984), p 340.
- ^{xxiii}Ibid.
- ^{xxiv}Tacitus. *Ann.* 4.62. in Tacitus. *Tacitus: Annals Book I-IV*. Comp. R.H. Martin and A.J. Woodman. Trans. Rebecca Napolitano. (Cambridge University Press, New York, 2006).
- ^{xxv}Braja M. Das. *Principles of Geotechnical Engineering*, Ed. 1, (Brooks/Cole Engineering Division, California, 1984), p 341.
- ^{xxvi}F.G. Bell. *Engineering Properties of Soils and Rocks*. (Butterworth-Heinemann Ltd Linacre House, Oxford, 1992).
- ^{xxvii}Tacitus. *Ann.* 4.62. in Tacitus. *Tacitus: Annals Book I-IV*. Comp. R.H. Martin and A.J. Woodman. Trans. Rebecca Napolitano. (Cambridge University Press, New York, 2006).
- ^{xxviii}Timothy A. Philpot. *Mechanics of Materials*, Ed. 1, (John Wiley and Sons, Inc., NJ, 2008), p.2.
- ^{xxix}Timothy A. Philpot. *Mechanics of Materials*, Ed. 1, (John Wiley and Sons, Inc., NJ, 2008), p.249.
- ^{xxx}European Wood. "Fir: Abies Alba," European Wood , n.d. <http://jp.europeanwood.org/en/living-with-wood/selected-european-wood-species/fir/> (20 March 2015).
- ^{xxxi}Timothy A. Philpot. *Mechanics of Materials*, Ed. 1, (John Wiley and Sons, Inc., NJ, 2008), p.327.
- ^{xxxii}European Wood. "Fir: Abies Alba," European Wood , n.d. <http://jp.europeanwood.org/en/living-with-wood/selected-european-wood-species/fir/> (20 March 2015).
- ^{xxxiii}Wood Work Web. "Wood Strengths," Wood Work Web, 2008. <http://www.woodworkweb.com/woodwork-topics/wood/146-wood-strengths.html> (20 March 2015).
- ^{xxxiv}Roger B. Ulrich. *Roman Woodworking*, (Yale University Press, New Haven, 2007), p 59.
- ^{xxxv}Chris Maharaj, Andy Morris, and John P. Dear. "Modelling of creep in Inconel 706 turbine disc fir-tree" *Materials Science and Engineering A* (2012).
- ^{xxxvi}Douglas Giancoli. *Physics*, Ed. 6, (Prentice Hall, New Jersey, 2005), p. 91.

CONCLUDING THOUGHTS

This project commenced with the desire to understand what happened to the amphitheater at Fidenae; it ran through the primary literary evidence, proximal archaeological remains, contemporary art and architecture, as well as other sources of evidence; finally, it manifested itself in a full 3-D rendering. It was only through the intersections of classics, architectural history, archaeology, and engineering that visualization for this amphitheater was even possible starting with so little evidence.

This thesis began with the words of Tacitus and Suetonius describing the collapse of the amphitheater at Fidenae mostly in terms of its carnage. Tacitus also included kernels of answers to what might have precipitated this disaster with his comments on the foundations and the joints of the structure. With the impetus for scientific inquiry given in the details, the following questions naturally came:

Did that many people *really* die?

What did this look like?

What did Atilius do so wrong?

After reading this through to completion, you might be seeing a parallel between the stream of consciousness that were my initial inquiries and how my chapters are organized; the three middle chapters of this work attack these questions respectively head on.

Due to the fact that there are no accurate models or direct archaeological evidence for the amphitheater at Fidenae, the most pragmatic route to answering the aforementioned questions was in the direction of proximal structures, or other amphitheaters, that were not just around the same geographic location, but around the same time period or constructed under similar circumstances and motivations. The foremost source for information concerning this was

Jean-Claude Golvin's work *Le Amphitheatre Romain* which goes through innumerable amphitheaters in depth with cross sectional areas and overhead sketches, with information concerning how the amphitheaters were built and what they were used for, with details of archaeological remains, et al. From these results I was able to understand the scale of a wooden amphitheater, find *exempla* in art such as that on Trajan's column, and really start to question what the scale of the amphitheater at Fidenae most probably would have been.

It was at this point when the primary literary evidence of Tacitus and Suetonius was again consulted, but this time in conjunction with the numbers presented in Golvin's work. From the data concerning proximal structures, a mean value for amphitheater seating capacity was established to be 28,900 and compared to the numbers of the primary sources—20,000ⁱ killed and 50,000ⁱⁱ maimed and killed. With the seating capacity of the amphitheater at Fidenae set amid these estimates at 37,400, formulae, as a function of seating capacity derived from Golvin's data, elucidated the trends between seating capacity and dimensions in order to create a two-dimensional layout for the amphitheater at Fidenae. However Golvin's data was only able to bring the work so far in the search for a visualization of this amphitheater. Depictions of various wooden constructions on Trajan's column needed to be consulted for how this amphitheater would have looked in a three-dimensional sense.

Once the three-dimensional layout had been established, I turned back on one of my original questions: What went wrong? At this point I had already come to terms with the fact that 37,400 people had been killed and what this amphitheater had most probably looked like, but what precipitated the disaster? I was able to use the approaches I had learned in my engineering classes—looking at shear stress, axial stress, bending stress, looking at the moments in the soil—to fully understand what possibly went wrong. GIS allowed for the further understanding that if

Atilius had not dug to bedrock 120cm down, like Tacitus had alluded to, that this depth would have been too shallow to incur the load of people. With the pile in motion, it was clear that the amphitheater was going to collapse, but just how it would do so was something else that was able to be calculated from the information accrued. The bifurcation alluded to in the first chapters did indeed occur, but if Figures 2.4 and 4.16 are compared below, it can be seen that it occurred in a different way than initially anticipated by the text.

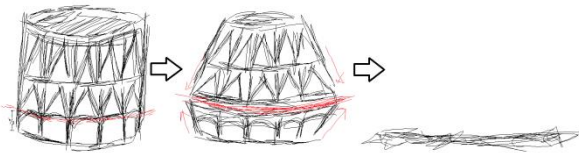

Figure 2.4



Figure 4.16

The collapse of the amphitheater at Fidenae was due to the foundations not being laid to a deep enough stratum, and in turn, causing the joints to incur more stress than they had been engineered for. Failure at Fidenae was imminent.

This project was able to solve a 2000 year old enigma—what happened in AD 27 at Fidenae. While the results of this thesis do not yield what the amphitheater and collapse *definitely* looked like, they do provide what these *most probably* looked like—and that is pretty powerful. At the intersection of classics and physics, or the humanities and the sciences, it is possible to pose logical questions and garner grounded solutions that either side has not been able to previously address. The intersections of these disciplines are where the emerging research is—it's not called the cutting edge for no reason. It is the apex of divergent disciplines which forces its way through the constraints set upon individual academic interests and allows new

fields to grow, new ways of thinking to emerge, and 2000 year old amphitheaters to be put back together—and that’s pretty amazing. I am not saying that this is completely what I was thinking when I started this work by googling “Roman structural disasters,” but I can say that this is something I have learned in my work and I hope that you have too.

ⁱSuetonius. *Tib.* 40. in Suetonius. *Life of Tiberius*. Comp. Mary Johnstone Du Four and Joannes Renier Rietra. Trans. Rebecca Napolitano. (Arno Press, New York, 1979).

ⁱⁱTacitus. *Ann.* 4.63. in Tacitus. *Tacitus: Annals Book I-IV*. Comp. R.H. Martin and A.J. Woodman. Trans. Rebecca Napolitano. (Cambridge University Press, New York, 2006).

REFERENCES

- Anjali Mehrotra and Branko Glisic. "Reconstruction of the appearance and structural system of Trajan's Bridge" *Journal of Cultural Heritage*. 16, (2014).
- Braja M. Das. *Principles of Geotechnical Engineering*, Ed. 7, (Cengage Learning, Stamford, 2010).
- Chris Maharaj, Andy Morris, and John P. Dear. "Modelling of creep in Inconel 706 turbine disc fir-tree" *Materials Science and Engineering A* (2012).
- Douglas Giancoli. *Physics*, Ed. 6, (Prentice Hall, New Jersey, 2005).
- Edoardo A. Costantini, Ferdinando Urbano, and Giovanni L'Abate, "Soil Regions of Italy" *Centro Nazionale Cartografia Pedologica*, 2004, http://soilmaps.entecra.it/download/csi-BrochureSR_a4.pdf (17 March 2015).
- Eric Meier. "European Silver Fir," *The Wood Database*, 2014, <http://www.wood-database.com/lumber-identification/softwoods/european-silver-fir/> (20 March 2015).
- European Wood. "Fir: Abies Alba," *European Wood*, n.d. <http://jp.europeanwood.org/en/living-with-wood/selected-european-wood-species/fir/> (20 March 2015).
- F.G. Bell. *Engineering Properties of Soils and Rocks*. (Butterworth-Heinemann Ltd Linacre House, Oxford, 1992).
- Frank Lepper and Sheppard Frere. *Trajan's Column*. (Alan Sutton Publishing, Inc., New Hampshire, 1988), p. 152
- Giovanni Uggeri. "Fidenae." *Brill's New Pauly*. Ed. Hubert Cancik and Helmuth Schneider. Brill Online. 2015. <http://referenceworks.brillonline.com/entries/brill-s-new-pauly/fidenae-e411400?s.num=7> (21 Jan 2015).

- Hen-Magonza, "Trajan's Column." Flickr. 2012. <https://www.flickr.com/photos/hen-magonza/7161296699/> (3 March 2015).
- Jean-Claude Golvin. *L'Amphitheatre Romain: Essai sur la Theorsation de sa Forme et de ses Fonctions*. Trans. Caeli Smith. (Diffusion de Boccard, Paris, 1988).
- John Ochsorn. "Capacity of Wood Column Calculator," Cornell University, 2014. <https://courses.cit.cornell.edu/arch264/calculators/example7.1/index.html> (20 Feb 2015).
- Jonathan Roth. *The Logistics of the Roman Army at War: 264 B.C. –A.D. 235*. (Brill, Leiden, 1999).
- Keith Still. "Static Crowd Density (General.)" *Crowd Saftey and Crowd Risk Analysis*. 2014. <http://www.gkstill.com/Support/crowd-density/CrowdDensity-1.html> (10 Feb 2015).
- Lorenzo Quilici and Stefania Quilici Gigli. *Fidenae*, (Consiglio Nazionale delle Ricerche, Rome, 1986).
- P.G. W. Glare. *Oxford Latin Dictionary*, (Oxford University Press, United Kingdom, 2012).
- Party Vision, "Carnival Booth Options." 2015. < <http://www.partyvision.com/entertainment-events-rentals/carnival-booth-options/>> (27 Feb 2015).
- Phillips, Darryl A. *Tertullian on the Opening of Pompey's Theater in Rome*. *Syllecta Classica*, Volume 12 (2001), pg. 208-220.
- Rod Pierce. "Perimeter of Ellipse." *Math is Fun*. Ed. Rod Pierce. 10 Nov 2014. <http://www.mathsisfun.com/geometry/ellipse-perimeter.html> (22 Jan 2015).
- Roger B. Ulrich. *Roman Woodworking*, (Yale University Press, New Haven, 2007).
- Samuel Ball Platner. *The Topography and Monuments of Ancient Rome*, (Norwood Press, Boston, 1911).

Suetonius. *Life of Tiberius*. Comp. Mary Johnstone Du Four and Joannes Renier Rietra. Trans. Rebecca Napolitano. (Arno Press, New York, 1979).

Tacitus. *Tacitus: Annals Book I-IV*. Comp. R.H. Martin and A.J. Woodman. (Cambridge University Press, New York, 2006).

Timothy Philpot. *Mechanics of Materials: An Integrated Learning System*. Ed. 3. (Wiley, New Jersey, 2012).

United States Department of Agriculture. "Soil Texture Triangle" *Natural Resources Conservation Service Soils*, 1996,

http://www.nrcs.usda.gov/wps/portal/nrcs/detail/soils/survey/?cid=nrcs142p2_054167

(19 March 2015).

Vitruvius. *Vitruvius: Ten Books on Architecture*. Comp. and Trans. Ingrid D. Rowland and Thomas Noble Howe. (Cambridge University Press, New York, 1999.)

William Gell, Sir. *The Topography of Rome and Its Vicinity*, (Harrison and Co., London, 1846).

Wood Work Web. "Wood Strengths," Wood Work Web, 2008.

<http://www.woodworkweb.com/woodwork-topics/wood/146-wood-strengths.html> (20

March 2015).

APPENDIX A: NEEDED AND ALLOWABLE LOADS FOR VERTICAL SUPPORTS

The allowable loads for each post are paired with the necessary loads that each post would bear in this amphitheater. The naming system stems from the system laid out in Figure 3.1. In addition T1R1P1 would be the post closest to the arena, while post T1R1P4 would be further away, thereby the post numbers increase as the radius of the ellipse increases and reset with the changes.

Table A.1 Needed and Allowable Loads for Vertical Supports

Post Number	$P_{\text{Allowable}}$ (lb)	P_{Needed} (lb)
T1R1P1	663960	3512
T1R1P2	313500	3772
T1R1P3	153600	4032
T1R1P4	90040	3582
T2R2P1	407600	2487
T2R2P2	350800	2552
T2R2P3	235000	2617
T2R2P4	144700	2682
T2R2P5	94660	2747
T2R2P6	66090	2812
T2R2P7	48580	2877
T2R2P8	37150	2286

Post Number	P _{Allowable} (lb)	P _{Needed} (lb)
T3R3P1	407600	3219
T3R3P2	350800	3284
T3R3P3	235100	3349
T3R3P4	144800	3414
T3R3P5	94660	3479
T3R3P6	66090	3544
T3R3P7	48580	3609
T3R3P8	37150	1165
T1R2P1	77620	2491
T1R2P2	77620	2556
T1R2P3	77620	2621
T1R2P4	77620	2686
T1R2P5	77620	2751
T1R2P6	77620	2816
T1R2P7	77620	2881
T1R2P8	77620	2289

Post Number	P _{Allowable} (lb)	P _{Needed} (lb)
T2R3P1	37150	3229
T2R3P2	37150	3294
T2R3P3	371450	3359
T2R3P4	37150	3424
T2R3P5	37150	3490
T2R3P6	37150	3555
T2R3P7	37150	3620
T2R3P8	37150	1169
T1R3P1	77620	3229
T1R3P2	77620	3294
T1R3P3	77620	3359
T1R3P4	77620	3424
T1R3P5	77620	3490
T1R3P6	77620	3555
T1R3P7	77620	3620
T1R3P8	77620	1169

APPENDIX B: WEIGHT OF MATERIAL CALCULATIONS

The following calculation is for the purpose of determining the weight of materials in different sections of the amphitheater. T2R2 is utilized for the purpose of a sample calculation and the work for the remaining sections can be recreated using the data relevant to that particular section.

$$W_{T2R2} = \sum_{n=0}^7 \rho(V_n + 2C_n + H_n) \quad \text{Eq. B.1}$$

Where V=Volume of vertical Support

C=Volume of Cross Supports

H=Volume of Horizontal Supports

n=Number of the Support, with 0 being the outermost and 7 being the innermost.

Considering the outer most post of T2R2, the maximum height the vertical supports can be is 280in tall since that is the height which T2R2's last step rises to; this can be seen on the cross-sectional diagram in Chapter 2. Following each post successively inward, the heights of these will decrease by twice the height of the seat backs each time.

$$V_h = 280 - 2n(20.9) \quad \text{Eq. B.2}$$

Where V_h =Height of the vertical column in section T2R2 (in)

n=Number of the column, with zero being the outer most and seven being the innermost.

The vertical sections have a cross sectional area of 8"×8" and therefore the volume can be found by multiplying the cross-sectional area by Eq. B.2 found above.

The volume of the horizontal supports varies with the radius of the ellipse and can be found by multiplying one-seventy-fifth of the circumference by the cross sectional area of the cross supports. However the circumference varies however depending upon which post the

calculated the force of weight upon is desired. The area for the circumference of an ellipse is as follows.

$$C = 2\pi \sqrt{\frac{\left(\frac{A}{2}\right)^2 + \left(\frac{B}{2}\right)^2}{2}} \quad \text{Eq. B.3}$$

Where A=Major axis of the ellipse

B=Minor axis of the ellipse

In order to account for the variance in the circumference, twice the length of two seat bottoms has to be subtracted from the circumference of the outermost post of T2R2 for each successive post. The formula is as follows.

$$C = 2\pi \sqrt{\frac{\left(\frac{A_{T2R2} - (2)(2)(20.9)n}{2}\right)^2 + \left(\frac{B_{T2R2} - (2)(2)(20.9)n}{2}\right)^2}{2}} \quad \text{Eq. B.4}$$

Where A_{T2R2} =Major axis at back of the outermost post of T2R2 (in)

B_{T2R2} =Minor axis at back of the outermost post of T2R2. (in)

n= Number of the column, with zero being the outer most and seven being the innermost.

The horizontal supports have a cross sectional area of 12”×12” and therefore the volume of these supports can be found by multiplying the Eq B4 above by the cross sectional area.

The value of the cross supports varies with the height of each post as well as with the radius of the ellipse.

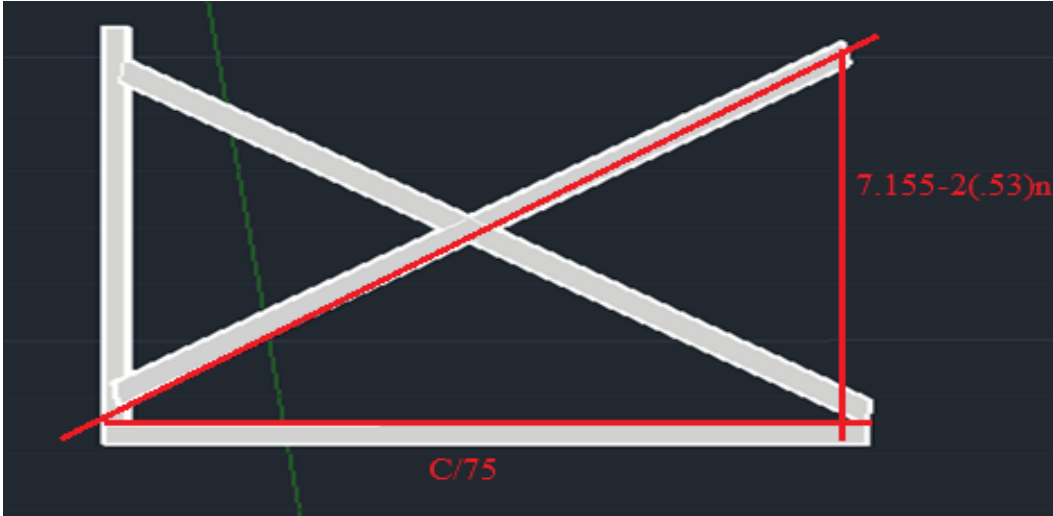

Figure B.1: Visual Aid in Calculating Varying Length of Cross Supports

Therefore the variable length of each cross support is the hypotenuse of the triangle shown in figure --- where C can be found by Eq. B.4 above

$$C_l = \sqrt{\left(\frac{2\pi}{75}\right)^2 \frac{(A_{T2R2} - (2)(2)(20.9)n)^2}{2} + \frac{(B_{T2R2} - (2)(2)(20.9)n)^2}{2} + (280 - 2(.53m)n)^2} \quad \text{Eq. B.5}$$

Where C_l = Length of the cross support (in)

The cross supports have a cross sectional area of 2"×4" and therefore the volume of these can be found by multiplying Eq. B.5 above by the cross sectional area.

With each of the volumes having been found, these can be substituted back into Eq. B.1 to find the total weight for this section.

These steps can be repeated with the relevant numbers to find T3R3; the difference when calculating T3R2 is that the heights of the vertical cross sections do not vary which simplifies the calculations.

APPENDIX C: PILE CAPACITY

Table C.1 Post Capacity

Post	Capacity (lb)
T1R1P1	789
T1R1P2	847
T1R1P3	905
T1R1P4	804
T2R2P1	559
T2R2P2	573
T2R2P3	588
T2R2P4	602
T2R2P5	617
T2R2P6	631
T2R2P7	646
T2R2P8	513
T3R3P1	723
T3R3P2	737
T3R3P3	752
T3R3P4	767
T3R3P5	781
T3R3P6	796
T3R3P7	810
T3R3P8	262
T1R2P1	562
T1R2P2	576
T1R2P3	591
T1R2P4	606
T1R2P5	620
T1R2P6	635
T1R2P7	650
T1R2P8	516
T2R3P1	104
T2R3P2	106
T2R3P3	108
T2R3P4	111
T2R3P5	113
T2R3P6	115
T2R3P7	117
T2R3P8	38

Post	Capacity (lb)
T1R3P1	115
T1R3P2	117
T1R3P3	120
T1R3P4	122
T1R3P5	124
T1R3P6	126
T1R3P7	129
T1R3P8	42