**WCTE 2016**World Conference on
Timber Engineering

August 22-25, 2016 | Vienna, Austria

SHEAR RESISTANCE OF SCREWED TIMBER CONNECTIONS WITH PARALLEL TO GRAIN FRP REINFORCEMENTS

Luca Righetti¹, Marco Corradi², Antonio Borri³

ABSTRACT: Several applications involving the use of Fibre Reinforced Polymers (FRP) glued on the tension side of timber beams are available in literature. However, some drawbacks (durability, product cost and health and safety restrictions, difficulties in removal) have limited an intensive use of organic adhesives (i.e. epoxy resins, etc). A possible solution could be the use of metal screws, changing the nature of the connection from chemical to mechanical. This paper describes an experimental investigation on the mechanical behaviour of externally bonded FRP composites using steel screws. Two different composite materials have been considered: Carbon Fibre Reinforced Polymer (CFRP) and Glass Fibre Reinforced Polymer (GFRP) and three different metal screw types have been used. FRP strengthening was then applied to timber blocks and shear tested conducted to study the performance of the screwed connection. The response of the screwed connection was recorded: catastrophic collapse did not occur, as the connection failed gradually for slippage phenomena produced by screw yielding and wood displacement. The slippage between timber and FRP plate has been recorded and tests described in this paper demonstrated that the effectiveness of screwed FRP strengthening could be compromised by these phenomena.

KEYWORDS: Timber connections, Shear resistance, CFRP and GFRP plates, Steel screws

1 INTRODUCTION

Timber construction is an important part of the infrastructure in many areas of the world. Timber has been used as a building material since thousands of years, from the beginning of the civilization and the world's infrastructure still includes a wide range of timber structures. Timber is characterized by a high strength to weight ratio, is recyclable, relatively inexpensive compared with other building materials such as concrete or steel. However this material is regularly exposed to deterioration which could be the result of increased service loads, variation in moisture content, biological attack or aging [1-4].

The cross section of timber beams exposed to bending loads is subjected to longitudinal compression and tension stresses: the first produces elastic and plastic deformation while the second cause a brittle failure as a result of the fracture of the wood fibres.

Literature shows that the flexural capacity and stiffness of timber beams can be significantly improved by applying reinforcing elements. Recently Fibre

Reinforced Polymers (FRP) materials have been intensively used to increase the bending capacity of solid and glulam beams because of their excellent mechanical properties: high strength and stiffness to weight ratios, chemical stability and ease of application. Their popularity is largely due to the economy with which they may be applied. A number of research projects around the world have studied the mechanical performance of different bonded FRP reinforcing methods. The FRP materials can be applied inside the beam in form of pultruded rods [5-9] or plates [10-13] with the use of epoxy resins or adhesives. Because of weak of timber in tension an effective solution, recurrently used in literature, is glued or epoxied a FRP plate directly on the tensile surface of the beam [14-17]. The application of the strengthening element moves the neutral axis towards the bottom of the cross section and consequently the compressive strain in the timber grows compared with the tension stress and the failure may happen because of the compression yielding of the timber instead of a brittle failure in tension area.

The use of epoxy adhesives to apply FRP reinforcement presents some problems: for example heritage conservation authorities do not authorize an extensive use of organic adhesives [18] and ambient-cure adhesives soften at low glass transition temperatures. Also fire performance of bonded FRPs limits their use in constructions. The long term behaviour of epoxy resins and the effect of changing in moisture content are other factors restraining an intensive use of epoxy resins in strengthening interventions on timber structures.

¹ Luca Righetti, Mechanical and Construction Engineering Department, Northumbria University, Newcastle upon Tyne, United Kingdom, luca.righetti@northumbria.ac.uk

² Marco Corradi, Mechanical and Construction Engineering Department, Northumbria University, Newcastle upon Tyne, United Kingdom and Department of Engineering, University of Perugia, Perugia, Italy, marco.corradi@northumbria.ac.uk

³ Antonio Borri, Department of Engineering, University of Perugia, Perugia, Italy, antonio.borri@unipg.it

FRP strengthening is critically dependent upon the bonding with wooden substrate. A possible alternative to the use of organic adhesives is constituted by metal fasteners. In this case the connection type changes from chemical to mechanical. The application of the FRP composites without using epoxy resins has yet to be fully addressed and requires further research, although it has been the subject of studies in recent years. Dempsey and Scott [19] tested Southern Pine timber beams reinforced with two different FRP materials: Glass FRP (GFRP) and Hybrid FRP (HFRP) strips considering three different fastener layouts. Test results highlighted an increase of the ultimate bending moment up to 51.3% for beams reinforced with HFRPs.

Recently Righetti et al. [20] have investigated the bending behaviour of fir wood beams reinforced using Carbon FRP (CFRP) plates screwed on the tension side of the beams. Different reinforcement arrangements have been investigated. Results show an increase of the bending capacity up to 29.4%. In another investigation, Corradi et al. [21] compared the results of epoxy bonded and screwed FRP reinforcements and demonstrated that epoxy bonded strengthening has a higher effectiveness compared to a screwed one.

The main advantages in the use of screws are the economy (mainly in terms of installation time) with which it can be applied, the minimization of changes to the appearance of the timber structure and the reversibility of the intervention. Furthermore this reinforcement method could be used for temporary or intermediate works to stabilize timber structures. The mechanical behaviour of the metal fasteners is critical for effectiveness of the FRP strengthening. Understand the performance of the screws subjected to shear load on the contact surface between the timber beam and the FRP reinforcement and the transmission mechanism of the actions from the timber to the reinforcement element is a fundamental goal to achieve.

This paper describes a series of laboratory tests investigating the behaviour of screwed connections between hardwood timber (oak) and two FRP materials (CFRP and GFRP). FRP plates, mechanical bonded using metal screws to the surface of timber blocks, have been subjected to shear test.

2 MECHANICAL BEHAVIOUR OF TIMBER CONNECTION USING STEEL SCREWS

Several authors studied timber to timber and steel to timber connections [22-25]. The analysis of the behaviour of mechanical connections between timber elements using steel screws is based on the Johansen yielding theory [26]. This assumes a plastic behaviour for both wood and steel. In addition to the geometrical characteristics of the connection, two parameters are critical: the embedment of the timber material and the yielding capacity of the steel connector. The Johansen theory could be used also for timber – FRP plate connections. Three different failure modes can be considered (Fig. 1): timber or steel yielding, and failure caused by the formation of another plastic hinge over the

length of the screw in addition to the previous described in the second failure mode.

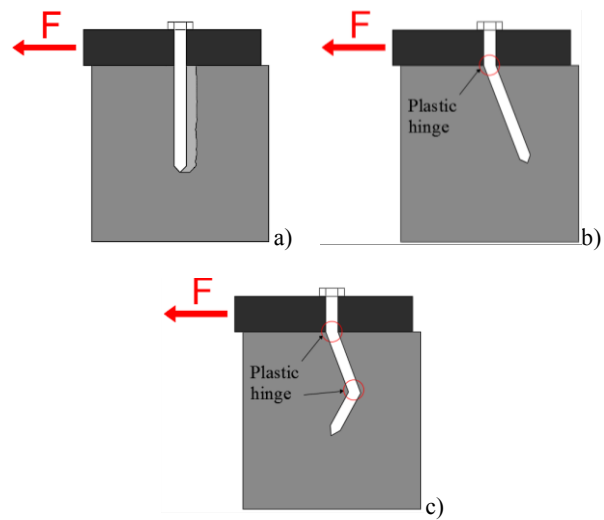

Figure 1: Failure mode of the connection system according with Johansen yield theory: a) timber yield plasticization; b) single plastic hinge in the steel screw at the timber-FRP interface; c) two plastic hinges in the steel screw.

3 MATERIAL CHARACTERIZATION

3.1 TIMBER

Oak wood (*Quercus robur*) (Fig. 2), characterized by an average weight density of 708.04 kg/m^3 (Standard Deviation (SD) = 45.77 kg/m^3), has been used for all the tests. A moisture content of 9.26% (SD = 0.86%) was experimentally evaluated in accordance with EN 13183-1: 2002 standard [27]. In order to evaluate the average parallel to grain compressive strength five specimens have been tested in accordance with EN 408: 2003 standard [28]. Tests results shows an average compressive strength of 65.28 N/mm^2 (SD = 3.52 N/mm^2).



Figure 2: Oak wood (*Quercus Robur*)

3.2 CFRP PLATE

A pre-impregnated CFRP plate made of with a double layer of carbon fibres with a wave pattern “2/2 Twill” in which the weft went over two intersecting warps and then under two in order to create a fabric with a diagonal pattern (Fig. 3a). Reinforced material is manufactured in plate with length of 600 mm, width of 57 mm and thickness of 3 mm. Three specimens have been tested in tension in according with ASTM D 3039 standard [29].

Tensile strength and Young's modulus were 674.73 N/mm^2 (SD = 16.67 N/mm^2) and 9370.37 N/mm^2 (SD = 248.43 N/mm^2) respectively.

3.3 GFRP PLATE

The pultruded GFRP plates (Fig. 3b) were made from glass reinforced isophthalic polyester resin reinforced with E-glass fibre. GFRP plate cross-section was 80 mm (width) x 8 mm (thickness). Five specimens have been tested in tension according to [29]. Test results highlighted an average value of the tensile strength of 381.8 N/mm^2 (SD = 25.2 N/mm^2) and of the Young's modulus equal to 3533 N/mm^2 (SD = 639 N/mm^2).

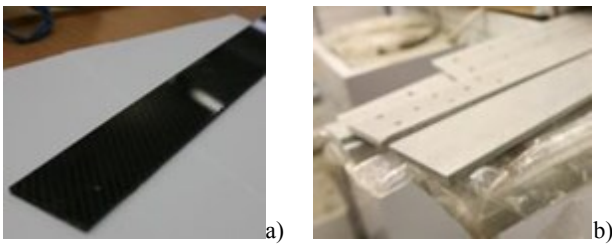

Figure 3: FRP plates: a) CFRP; b) GFRP

3.4 CONNECTORS

Three different types of steel coach screws (Fig. 4) were used. All connectors were designated by the manufacturer as 4.6 in strength grade according with EN 3692: 2014 standard [30] (nominal tensile strength and yield stress are 400 and 240 N/mm^2 , respectively). The three typologies used are different in terms of nominal diameter and length. Table 1 summarizes their geometrical characteristics.

Table 1: Geometrical characteristics of the screw

Type	Nominal diameter [mm]	Length [mm]
1	6	50
2	8	45
3	8	50

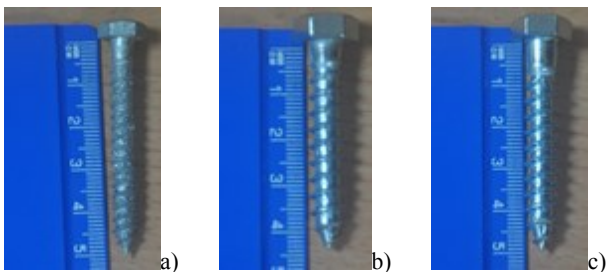

Figure 4: Steel coach screws used in the experimental campaign: a) type 1; b) type 2; c) type 3

4 EXPERIMENTAL PROGRAM

In order to evaluate the shear resistance of screwed connections between a timber specimen and a composite plate, an unconventional shear test, with a specific set-up designed exclusively for the research purpose by the

authors, was carried out using a tensile machine Lloyds LR100k. A single lap shear test has been used to study the behaviour of the screwed connection between a composite plate and a wood substrate. This will be described in detail in Section 4.2.

4.1 TEST SPECIMENS

Fifteen oak-wood prismatic specimens with dimensions of $70 \times 70 \times 80 \text{ mm}$ have been cut from the same batch of beams. Composite plates have been screwed to the wood specimen using a single steel coach screw (Fig 5). The geometry of the composite plates is shown in Figs. 6-7: both reinforcing elements were machined into 58 mm sections with a reduction to 40 mm to allow for central positioning in the tensile machine jaws.

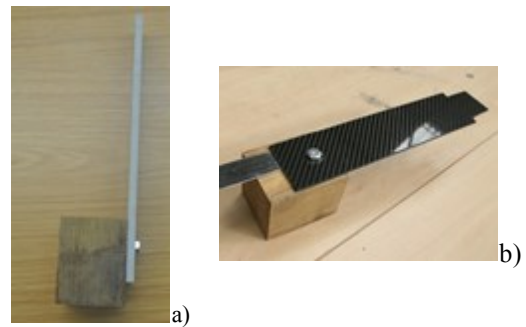

Figure 5: Specimen used in the experimental campaign: a) GFRP; b) CFRP

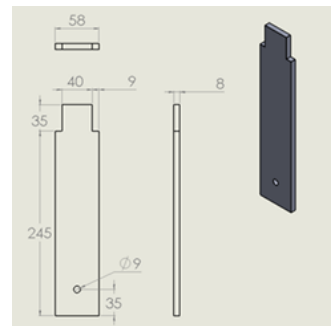

Figure 6: Geometry of GFRP plates used in the test (dimensions in mm)

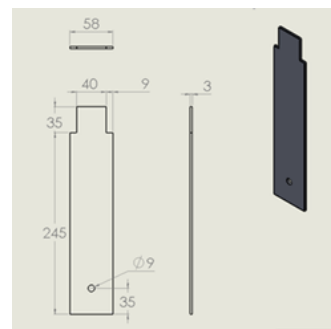

Figure 7: Geometry of CFRP plates used in the test (dimensions in mm)

Screws are applied perpendicular to the grain in order to be consistent with the reinforcement technique available

in literature for the timber beams subjected to bending loads.

Table 2: Test matrix

Index	Reinforcement plate	Screw type
G1	GFRP	1
G2	GFRP	2
C2	CFRP	2
G3	GFRP	3
C3	CFRP	3

Table 2 shows the test matrix. Each specimen has been designated with an index: the first letter indicates the type of reinforcement material, C and G respectively for CFRP and GFRP; the second is a number from 1 to 3, which defined the steel screw type and finally, the third a progressive number (from 1 to 3).

4.2 TEST SET-UP

Tests were carried out using a dynamometer type Lloyd LR100k with a load cell of 100 kN. Because the instrument was not designed specifically to apply directly shear load modification were necessary. For this specific purpose two steel frames (Fig. 8) have been designed, one for the GFRP and the other for the CFRP specimens.

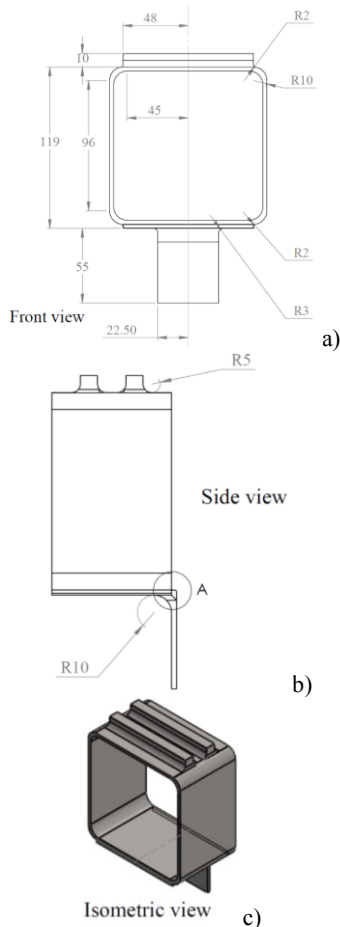

Figure 8: Third angle projection of steel bracket used for CFRP specimens: a) Front view; b) Side view; c) Isometric view

The steel bracket is composed of a square-section steel tube and a L-shaped profile welded together. The L-shaped profile has been used in order to connect the specimen to the jaw of the tensile machine. Because the thickness of the CFRP and GFRP plates was different, two different steel brackets have been used. This was necessary in order to achieve perfect alignment between the L-shaped steel profile and composite plate. In detail, the L bracket underneath the box section is offset by 3 mm for the C-specimens and 8 mm for the G-specimens (Fig. 9).

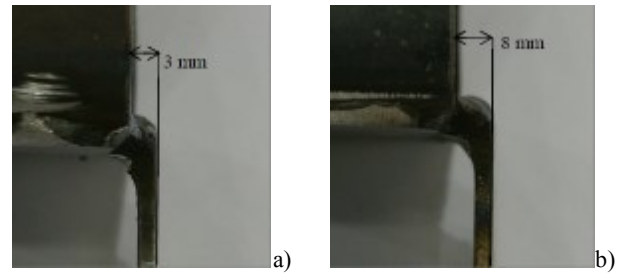

Figure 9: L-shaped profile's position: a) C-specimens; b) G-specimens

The timber block reinforced with the FRP plate was inserted inside the steel bracket and the plate has been fixed on the tensile machine joints before starting the test. In order to reduce the deformation of the upper internal surface of the steel box due to the timber compression, two 10 mm square steel bars have been welded on the top surface of the steel box. The slippage between the timber prism and the screwed plate have been measured using a Linear Variable Differential Transducer (LVDT) applied on an aluminium reference plate glued on the plate and fastened securely to the timber using a 28 mm rubber lined pipe clip. The LVDT was connected to a data-logger and the displacement and the load applied have been recorded simultaneously. All tests were conducted with a crosshead speed of 0.4 mm/min (displacement control mode). Figure 10 shows the test set-up.



Figure 10: Test set-up

5 RESULTS

Table 3 gives the results of the shear tests. Results are in terms of maximum shear load (F_{\max}), and slippage (δ_{\max}) between the timber element and the FRP plate and the failure mode. Specimens' failure was usually due to the screw yielding at the interface between timber and composite plate. The failure was never due to the wood yielding in compression because of the high mechanical characteristics of the hardwood used in the experimental campaign, but displacement of the timber material around the hole has been also observed. In Table 3 the failures have been labelled as Mode 1 and Mode 2 for the failure due to the formation of a single plastic hinge (Fig. 11a) or to a double plastic hinge (Fig. 11b) in the screw respectively. The screw type 1 exhibit a brittle failure at the interface between the timber element and the plate due probably to its smaller diameter.

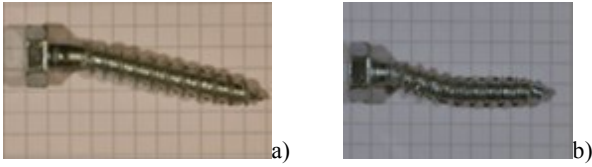

Figure 11: Failure modes: a) screw yielding at the interface between timber and plate (Mode 1); b) screw yielding in two sections (Mode 2)

Table 3 shows the characteristic screw's load-carrying capacity ($F_{v,Rk}$) of the connection calculated according with EN 1995-1-1 [31] standard. For the failure Mode 1 the characteristic shear load-carrying capacity is defined by the following equation:

$$F_{v,Rk} = f_{h,k} \cdot t_1 \cdot d \left[\sqrt{2 + \frac{4M_{y,Rk}}{f_{h,k} \cdot d \cdot t_1^2}} - 1 \right] + \frac{F_{ax,Rk}}{4} \quad (1)$$

where $f_{h,k}$ = characteristic embedment strength in timber member, t_1 = penetration depth, d = screw's diameter, $M_{y,Rk}$ = characteristic screw yield moment, $F_{ax,Rk}$ = characteristic axial withdrawal capacity of the screw. Because the value of $F_{ax,Rk}$ is unknown, in accordance with [27], it has assumed equal to zero. According with the same standard, $f_{h,k}$ and $M_{y,Rk}$ have been evaluated with the following:

$$f_{h,k} = 0.082 \cdot (1 - 0.01 \cdot d) \cdot \delta_k \quad (2)$$

where: d = screw's diameter, δ_k = characteristic timber density;

$$M_{y,Rk} = 0.3 \cdot f_{u,k} \cdot d^{2.6} \quad (3)$$

where: $f_{u,k}$ = characteristic tensile strength of the fastener's material, d = fastener's diameter.

For the failure Mode 2, $f_{y,Rk}$ is given by the following:

$$F_{v,Rk} = 2.3 \cdot \sqrt{M_{y,Rk} \cdot f_{h,k} \cdot d} + \frac{F_{ax,Rk}}{4} \quad (4)$$

The values of the failure loads are usually smaller compared to the screw's shear load-carrying capacity given by eq. (1) and (4). This could be produced by the wood displacement in the area around the hole and the resulting bending behaviour of the screw. During the shear test, the hole drilled on the FRP plates has been subjected to deformation which produced an ovalization

of the hole up to approx. 12-14 mm for the GFRP plates and 10.5 mm for the CFRP (Fig. 12) in the direction of the shear load. The original nominal diameter was 9 mm.

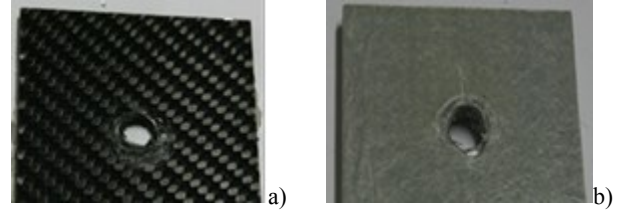

Figure 12: Ovalization of the hole: a) CFRP; b) GFRP

For each specimen shear load and slippage have been recorded during the tests (Figs. 13-17). The maximum value of the shear load has been obtained by using 8 mm-diameter screws (length of 45 mm - type 2). The screw type 1, characterized by a smaller nominal diameter, led to lowest value in terms of maximum shear load. As expected, the slippage values have decreased by increasing the screw diameter. However, the application of 8 mm-diameter screw (length of 50 mm) on the GFRP specimens exhibited the smallest value of shear load and biggest value of slippage: this was also due to the larger thickness of the GFRP plate compared to the carbon one: this produced a smaller penetration on the screw into the wood. As a consequence, specimens reinforced with CFRP plate exhibited smaller slippage compared with the GFRP ones. This could probably explain considering the lower deformation capacity of the CFRP plates.

Table 3: Test results (SD = Standard Deviation)

Index	F_{\max} [kN]	$F_{v,Rk}$ [kN]	δ_{\max} [mm]	Failure mode [-]
G1_1	5.37	4.68	10.66	Mode 2
G1_2	5.25	4.68	12.43	Mode 2
G1_3	4.93	4.68	12.45	Mode 2
Average	5.18	-	11.85	-
SD	0.23	-	1.03	-
G2_1	8.71	8.79	9.99	Mode 1
G2_2	8.28	7.77	9.95	Mode 2
G2_3	8.33	8.79	9.37	Mode 1
Average	8.44	-	9.77	-
SD	0.24	-	0.35	-
G3_1	6.62	9.59	14.32	Mode 1
G3_2	5.85	9.59	16.81	Mode 1
G3_3	5.96	9.59	13.99	Mode 1
Average	6.14	-	15.04	-
SD	0.42	-	1.54	-
C2_1	7.69	8.79	7.97	Mode 1
C2_2	6.98	8.79	6.33	Mode 1
C2_3	4.44	8.79	6.06	Mode 1
Average	6.37	-	6.79	-
SD	1.71	-	1.03	-
C3_1	5.79	9.59	3.47	Mode 1
C3_2	6.47	9.59	3.66	Mode 1
C3_3	6.17	9.59	2.63	Mode 1
Average	6.14	-	3.25	-
SD	0.34	-	0.55	-

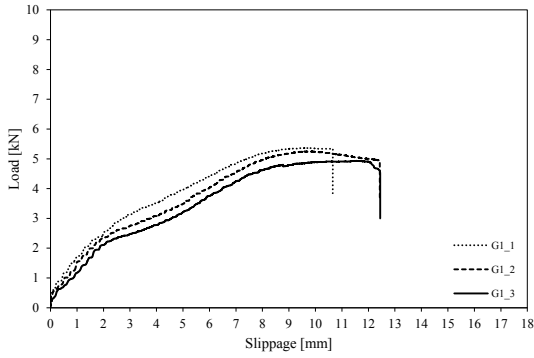

Figure 13: Shear load vs slippage curves for G1-samples.

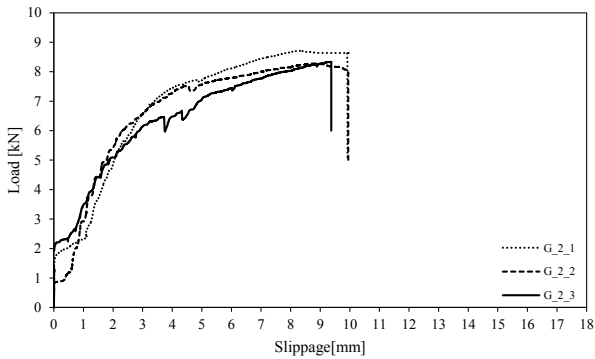

Figure 14: Shear load vs. slippage curves for G2-samples.

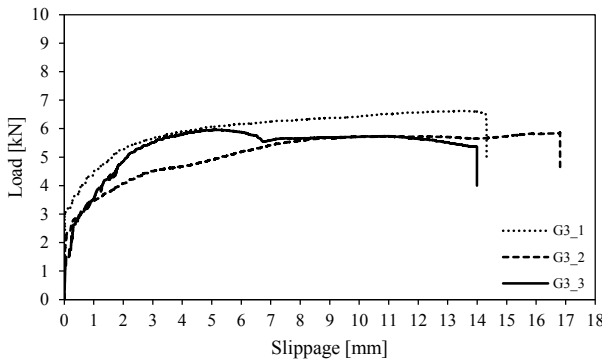

Figure 15: Shear load vs. slippage curves for G3-samples.

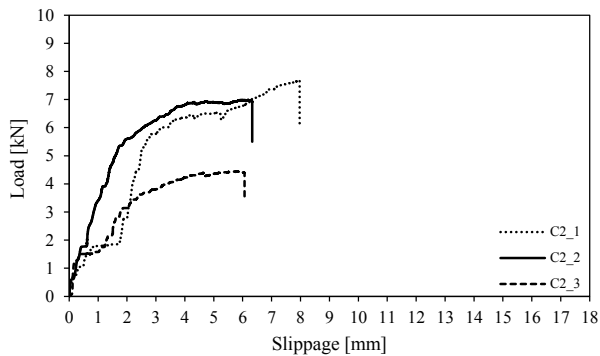

Figure 16: Shear load vs. slippage curves for C2-samples.

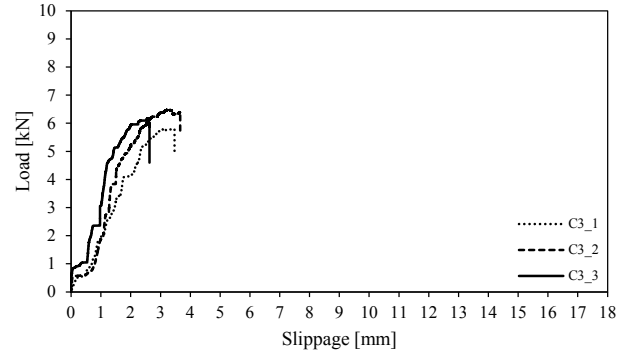

Figure 17: Shear load vs slippage curves for C3-samples.

Table 4 reports the values of the slippage for different load levels for all tested specimens.

Table 4: Slippage values for different load levels (SD = Standard Deviation)

Index	$\delta_{F_{max}}$ [mm]	$\delta_{0.2F_{max}}$ [mm]	$\delta_{0.4F_{max}}$ [mm]	$\delta_{0.6F_{max}}$ [mm]	$\delta_{0.8F_{max}}$ [mm]
G1_1	10.66	0.46	1.50	3.16	5.76
G1_2	12.43	0.71	1.66	4.15	6.30
G1_3	12.45	0.84	1.84	4.50	6.43
Average	11.85	0.67	1.67	3.94	6.16
SD	1.03	0.19	0.17	0.70	0.36
G2_1	9.99	0.06	1.38	2.15	3.38
G2_2	9.95	0.65	1.75	1.75	3.04
G2_3	9.37	0.55	1.08	3.22	4.32
Average	9.77	0.42	1.40	2.37	3.58
SD	0.35	0.32	0.34	0.76	0.66
G3_1	14.32	0.03	0.04	0.56	2.05
G3_2	16.81	0.01	0.08	1.08	4.08
G3_3	13.99	0.03	0.29	1.01	1.91
Average	15.04	0.02	0.14	0.88	2.68
SD	1.54	0.01	0.13	0.28	1.21
C2_1	7.97	0.72	2.04	2.42	3.51
C2_2	6.33	0.34	0.81	1.34	1.97
C2_3	6.06	0.14	1.23	1.58	2.39
Average	6.79	0.40	1.36	1.78	2.62
SD	1.03	0.29	0.63	0.57	0.80
C3_1	3.47	0.73	1.16	1.66	2.16
C3_2	3.66	0.86	1.13	1.51	1.98
C3_3	2.63	0.55	0.97	1.09	1.42
Average	3.25	0.71	1.09	1.42	1.85
SD	0.55	0.16	0.10	0.30	0.39

Figure 18 shows the shear load-slippage curves for each sample type. For low load levels the slippage exhibited a linear trend with magnitudes smaller than 2 mm. As the load increases, the slippage also increased. The behaviour of the specimens with screw type 1 showed a different trend compared with the other specimens; in fact the slippage between the GFRP plate and timber increased more compared with the other specimens from the 40% of the maximum load.

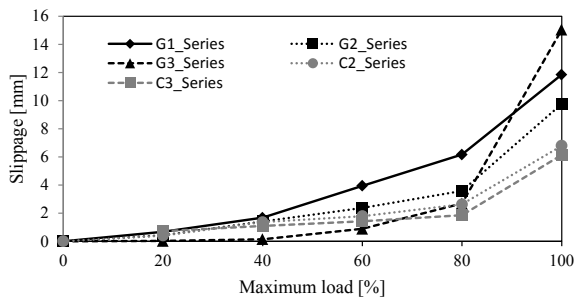

Figure 18: Slippage vs. shear load values for all the specimens tested

6 CONCLUSIONS

The application of composite plates on the tension side of timber beams represents an effective method to increase the bending capacity and stiffness of timber beams. The use of organic adhesives to bond the composite reinforcement to the timber has been widely experimented in the past, but presents problems with regard to bond durability, product cost and health and safety restrictions.

With the aim to foster better long run behavior, provide reinforcement reversibility, meet the requirements of conservation bodies, the use of mechanical connections may represent an interesting solution.

This study was aimed at investigating the capacity and the deformation characteristics of screwed connections between hardwood and composite materials. In this context the analysis of the slippage phenomena is critical as it may compromise the reinforcement effect when used to strengthen a wood element subjected to bending. Several single lap shear tests have been conducted using different types of metal screws.

The following conclusions are drawn based on the test results of this research:

1. Results show that the maximum shear load is usually smaller than the shear load-carrying capacity of the screw given by the standard.
2. High values of slippage have been recorded during the experimental investigation. However the slippage values decreased by increasing the screw diameter and length.
3. Two typical failure modes have been observed. The first was characterized by the screw yielding on a section at the interface between timber and composite plate and the second by the screw yielding in two different screw sections.
4. For low values of the shear load (up to 40% of the maximum) the slippage between plate and wood elements exhibited a linear behavior. As the load increases, the slippage also increased, but this increment was larger in magnitude as a consequence of the screw yielding and wood displacement around the hole.
5. The effectiveness of mechanical connections to bond a composite plate on the tension side of a timber element in bending can be seriously compromised by the slippage phenomena produced by the connector yielding and wood displacement and this research demonstrated that more tests are necessary to study a

mechanical connection method where the slippage values are reduced in magnitude.

ACKNOWLEDGEMENT

The authors gratefully acknowledge research support fund from Northumbria University at Newcastle Upon Tyne (UK) and the Building & Construction Materials Lab at Northumbria University for the use of test and measurement equipment critical to the collection and evaluation of the data presented. The experimental program was carried out with the help of Benjamin Gilvey, undergraduate student. Authors are also grateful for help and support in the laboratory activities to Christopher Walton, Matthew Dundas and Leon Amess.

REFERENCES

- [1] Gerhards C. C.: Effect of moisture content and temperature on the mechanical properties of wood: an analysis of immediate effects. *Wood and Fiber*, 14(1):4-36, 1982.
- [2] Zabel R. A., Morrell J. J.: *Wood microbiology: decay and its prevention*. Academic Press Limited, 1992.
- [3] Franke S., Franke B., and Harte A. M.: Failure modes and reinforcement techniques for timber beams – State of the art. *Construction and Building Materials*, 97:2-13, 2015.
- [4] Bodig J., Jayne B. A.: *Mechanics of wood and wood composites*. Van Nostrand Reinhold, 1982.
- [5] Gentile C., Svecova D., and Rizkalla S. H.: Timber beams strengthened with GFRP bars: development and applications. *Journal of Composites for Construction*, 6(1):11-20, 2002.
- [6] Borri A., Corradi M., and Grazini A.: A method for flexural reinforcement of old wood beams with CFRP materials. *Composites Part B: Engineering*, 36(2):143-153, 2005.
- [7] Raftery G. M., Kelly F.: Basalt FRP rods for reinforcement and repair of timber. *Composites Part B: Engineering*, 70:9-19, 2015
- [8] Righetti L., Corradi M., and Borri A.: Basalt FRP spike repairing of wood beams. *Fibers*, 3(3): 323-337, 2015.
- [9] Serrano E.: Glued-in rods for timber structures – an experimental study of softening behaviour. *Materials and Structures*, 34(4):228-234, 2001.
- [10] Raftery G. M., Harte A. M.: Low-grade glued laminated timber reinforced with FRP plate. *Composites Part B: Engineering*, 42(4):724-735, 2011.
- [11] D'Ambrisi A., Focacci F., and Luciano R.: Experimental investigation on flexural behaviour of timber beams repaired with CFRP plates. *Composite Structures*, 108:720-728, 2014.
- [12] Nowak T. P., Jasiński J., and Czepizak D.: Experimental tests and numerical analysis of historic bent timber elements reinforced with CFRP

- strips. *Construction and Building Materials*, 40:197-206, 2013.
- [13] Schober K. U., Rautenstrauch K.: Post-strengthening of timber structures with CFRP's. *Material and Structures*, 40(1):27-35, 2007.
- [14] Borri A., Corradi M. and Grazini A.: FRP reinforcement of wood elements under bending loads. In: 10th International Conference on Structural Faults and Repair, 2013.
- [15] Li Y. F., Xie Y.M. and Tsai, M. J.: Enhancement of the flexural performance of retrofitted wood beams using CFRP composite sheets. *Construction and Building Materials*, 23(1):411-422, 2009.
- [16] Andor K., Lengyel A., Polgar R., Fodor T. and Karácsosny Z.: Experimental and statistical analysis of spruce timber beams reinforced with CFRP fabric. *Construction and Building Materials*, 99:200-207, 2015.
- [17] Plevris N., Triantafillou T.: FRP-Reinforced wood as structural material. *Journal of Materials in Civil Engineering*, 4(3):300-317, 1992.
- [18] Papanicolau C. G., Triantafillou T. C., Papathanasiou M. and Karlos K.: Textile reinforced mortar (TRM) versus FRP as strengthening material of URM walls: out-of-plane cycling loading. *Material and Structures*, 41:143-157, 2008.
- [19] Dempsey D. D., Scott D. W.: Wood members strengthened with mechanically fastened FRP strips. *Journal of Composites for Construction*, 10(5):392-398, 2006.
- [20] Righetti L., Corradi M. and Borri A.: Strengthening of timber beams with unbonded FRP composites. In: 11th International European Bridge Conference, 2015.
- [21] Corradi M., Borri A., Castori G. And Speranzini E.: Fully reversible reinforcement of softwood beams with unbonded composite plates. *Composite Structures*, 149:54-68, 2016.
- [22] Parisi M. A., Piazza, M.: Mechanics of plain and retrofitted traditional timber connections. *Journal of Structural Engineering*, 126(12):1395-1403, 2000.
- [23] Loss C., Piazza M., and Zandonini, R.: Connections for steel-timber hybrid prefabricated buildings. Part I: Experimental tests. *Construction and Building Materials*. In press, 2015.
- [24] Branco J. M., Jorge M., Sousa H., and Lourenço P.B.: Experimental analysis of Maritime pine and Iroko single shear dowel-type connections. *Construction and Building Materials*, 111: 440-449, 2016.
- [25] Daudeville L., Davenne L. And Yasumura M.: Prediction of hte load carrying capacity of bolted timber joints. *Wood Science and Technology*, 33(1):15-29, 1999.
- [26] Johansen K. W.: Theory of timber connections. In: International Association of Bridge and Structural Engineering, 1949.
- [27] BS EN 13183-1:2002: Moisture content of a piece of sawn timber. British Standard Institute: London, UK, 2002.
- [28] BS EN 408:2010: Timber structures. Structural timber and glued laminated timber: determination of some physical and mechanical properties. British Standard Institute: London, UK, 2002.
- [29] ASTM D3039:2014: Standard test method for tensile properties of polymer matrix composite material. ASTM: West Conshohocken, PA, USA, 2014.
- [30] BS EN 3692:2014: ISO metric precision hexagon bolts, screws and nuts. Specification. British Standard Institute: London, UK, 2014.
- [31] EN 1995-1-1, Design of timber structures, Part 1-1: General-common rules for buildings. European Committee for Standardization, Brussels, Belgium, 2004.