

NORTHUMBRIA UNIVERSITY

**An Investigation into the History of the
Airbrush and the Impact of the
Conservation Treatment of Airbrushed
Canvas Paintings**

Mohamed Abdeldayem Ahmed Soltan

PhD

2015

An Investigation into the History of the
Airbrush and the Impact of the Conservation
Treatment of Airbrushed Canvas Paintings

Mohamed Abdeldayem Ahmed Soltan

A thesis submitted in partial fulfilment of the
requirements of the University of Northumbria
at Newcastle for the degree of
Doctor of Philosophy

Research undertaken in the
School of Arts and Social Sciences

April 2015

Abstract

The research considers whether traditional approaches to easel paintings conservation are appropriate for the treatment of air brush paintings.

The objectives were:

- To investigate the aesthetic and technical history of the airbrush
- To investigate surface changes in paint layers
- To investigate the appropriateness of traditional conservation treatments for airbrush paintings and evaluate alternative approaches

Although the first airbrush was introduced in 1883 it was initially rejected by many fine art circles as being too 'mechanical'. Airbrush techniques have been little discussed in the field of fine art and the field of the conservation of fine art.

A mixed methodology was followed for this research, qualitative through literature review carried out in line with the interdisciplinary nature of the research, and quantitative through various approaches including surveys. One survey was carried out in order to establish the use of air brush techniques by artists and its eventual acceptance as a fine art technique. A second survey was conducted to discover how well conservators understood the degradation characteristics of air brush paintings and their appropriate treatment. The research revealed that much of the eventual success of air brush painting resulted from the introduction of new types of paint in order to better manage the technique. It also revealed that there was a high level of uncertainty amongst practitioners in the field of paintings conservation with regard to the deterioration characteristics of air brush painting or their appropriate resolution. However the major concern with regard to conservation lay clearly within the field of image re-integration as a result of its characteristically smooth surface finish.

Artificial light ageing was carried out on simulated mock ups in order to develop a clearer understanding of the type of surface changes that might be expected over time from a limited palette of colours. This was followed by technical visual examination and media analysis via FTIR and Py-GC-MS methods. It was found that there were changes in surface morphology in some colours, which appeared to further enhance the smooth surface finish of the paint layer.

A range of approaches to image re-integration were trialled ranging from the traditional paint based approaches to the use of digital coloured light. The latter was of particular interest in offering a truly reversible non interventive approach to re-integration. The focus of the digital re-integration techniques was to evaluate the viability of its use in general practice. Due to the smooth surface as well as the build-up of multiple layers of colour the traditional approaches proved difficult to harmonise within the picture plain. The use of digital approaches using coloured light was more successful although further research is required in order to develop this approach for wide spread professional practice.

The physical and chemical characteristics of the airbrushed paint layer present issues that are fundamentally different to those found in oil paintings. As yet these are not all fully understood and require further research. Until such time the use of non interventive, reversible image re-integration techniques such as coloured light would be recommended.

Table of Contents

ABSTRACT	I
TABLE OF CONTENTS	II
LIST OF TABLES	VI
LIST OF FIGURES	VII
DEDICATION	XV
ACKNOWLEDGMENTS	XVI
DECLARATION	XVIII
INTRODUCTION: RESEARCH AIMS AND CONTEXTUALISATION	1
CHAPTER 1 – THE AIRBRUSH: TECHNICAL HISTORY	8
1.1 INTRODUCTION	8
1.2 AIRBRUSH: DEFINITION OF A TERM.....	8
1.3 COMPRESSED AIR: THE POWER FOR THE AIRBRUSH	9
1.4 A HISTORY OF THE AIRBRUSH	11
1.5 RECOGNITION OF THE NEW INSTRUMENT	16
1.6 A NEXT GENERATION OF THE AIRBRUSH AND THE END OF WALKUP’S AIR BRUSH	21
1.7 EARLY OPPOSITION TO THE AIR BRUSH	25
1.8 CONCLUSION.....	28
CHAPTER 2 – THE ROLE OF THE AIRBRUSH IN THE FIELD OF FINE ART	30
2.1 INTRODUCTION	30
2.2 THE ILLINOIS ART SCHOOL OF 1888: THE FIRST SCHOOL FOR AIRBRUSH	31
2.3 THE AIRBRUSH ART TOWARDS THE TWENTIETH CENTURY	37
2.4 THE AIRBRUSH AND TWENTIETH CENTURY FINE ART	40
2.4.1 <i>The 1910s</i>	42
2.4.2 <i>The 1920s</i>	44
2.4.3 <i>The 1930s</i>	47
2.4.4 <i>Post–World War II</i>	48
2.5 CONCLUSION.....	49
CHAPTER 3: AN OVERVIEW OF MODERN PAINTS AND ITS IMPACT ON THE USE OF THE AIRBRUSH IN FINE ART PAINTING	51
3.1 INTRODUCTION	51
3.2 MODERN PAINTS: THE ERA OF SYNTHETIC PAINT MEDIA	52
3.2.1 <i>In the Beginning were the House Paints</i>	53
3.2.2 <i>The Introduction of Artists Acrylic Paints</i>	54
3.3 ACRYLIC PAINTS	57
3.4 SYNTHETIC PAINTS IN THE ARTISTIC CONTEXT	59
3.5 SYNTHETIC PAINTS AND THE AIRBRUSH PAINTING	59
3.6 CONCLUSION.....	75
CHAPTER 4 - AN OVERVIEW OF IMAGE REINTEGRATION TREATMENTS FOR PAINTINGS CONSERVATION	77

4.1	INTRODUCTION	77
4.2	TERMINOLOGY	77
4.3	HISTORY	82
4.4	APPROACHES TO IMAGE REINTEGRATION.....	85
4.4.1	<i>Interventive Retouching</i>	85
4.4.1.1	Imitative	85
4.4.1.2	Non-imitative	88
4.4.2	<i>Non-interventive Retouching</i>	89
4.4.2.1	The case of Rothko's Harvard Murals	90
4.4.2.2	The non-interventive image reintegration of Rothko's Harvard Murals	93
4.4.2.3	Previous attempts to use projected illumination for non-interventive restoration.....	95
4.4.2.4	Pros and cons of the non-interventive image reintegration approach employed in the case of the Rothko's Harvard Murals.....	97
4.5	ETHICS AND AESTHETICS: PHILOSOPHICAL ISSUES PERTAINING TO IMAGE REINTEGRATION	100
4.6	CONCLUSION	104
CHAPTER 5: SURVEY		105
5.1	INTRODUCTION	105
5.2	OBJECTIVES OF THE SURVEY	106
5.3	STRATEGY OF THE SURVEY	107
5.4	DESIGNING THE QUESTIONNAIRE	108
5.5	THE QUESTIONNAIRE AIMED AT CONSERVATORS OF EASEL PAINTINGS.....	110
5.6	THE RESEARCH SAMPLE.....	112
5.7	THE DEMOGRAPHIC PROFILE OF RESPONDENTS.....	112
5.8	CAREER-RELATED QUESTIONS	113
5.9	ATTITUDINAL QUESTIONS.....	114
5.10	BRANCHING QUESTION.....	116
5.11	QUESTIONS ONLY RELATED TO RESPONDENTS WITH DIRECT EXPERIENCE IN AIRBRUSH EASEL PAINTINGS:	116
5.12	OPEN-ENDED QUESTIONS	118
5.13	VERBATIM RESPONSES TO THE OPEN-ENDED QUESTIONS	119
5.14	THE QUESTIONNAIRE AIMED AT FINE ARTISTS WHO ARE USED AIRBRUSH IN THEIR WORK	120
5.15	CONCLUSION.....	120
CHAPTER 6 – CHEMICAL ANALYSIS, LIGHT AGEING TEST AND SEM IMAGING OF ACRYLIC PAINT SAMPLES: EXPERIMENTAL AND RESULTS		122
6.1	INTRODUCTION: SYNTHETIC PAINTS IN THE CONTEXT OF ART CONSERVATION	122
6.2	OVERVIEW OF THE ANALYTICAL TECHNIQUES USED IN THIS STUDY.....	123
6.3	INVESTIGATION OF ACRYLIC GESSO AND THREE ACRYLIC PAINTS	124
6.3.1	<i>Samples investigated in this report:</i>	124
6.3.2	<i>Experimental</i>	125
6.3.2.1	Fourier Transform Infra-red (FTIR) Analysis	125
6.3.2.2	Pyrolysis GC-MS analysis.....	125
6.3.3	<i>Results and Discussion</i>	125
6.3.3.1	Investigation of the sample 1, Raphael 'Acrylic gesso', white.....	125
6.3.3.2	Investigation of sample 2, Golden Company, Primary yellow.....	126
6.3.3.3	Investigation of sample 3, Golden Company, Primary Magenta	126
6.3.3.4	Investigation of sample 4, Golden Company, Primary Cyan	127
6.3.4	<i>Conclusions</i>	137
6.4	ACCELERATED LIGHT AGEING TESTS	137
6.4.1	<i>Introduction</i>	137

6.4.2	<i>Overview of accelerated ageing methods in the field of art conservation</i>	138
6.4.3	<i>Aims and Objectives</i>	139
6.4.4	<i>Accelerated Light Ageing Test no. 1</i>	140
6.4.4.1	Sample preparation	140
6.4.4.2	Sample exposure conditions	140
6.4.4.3	Spectrophotometry Reading Procedure	142
6.4.4.4	Results and conclusions	144
6.4.5	<i>Accelerated Light Ageing Test no. 2</i>	146
6.4.5.1	Results and conclusions	146
6.5	SEM (SCANNING ELECTRON MICROSCOPY) IMAGING OF THE SAMPLES	147
6.5.1	<i>Introduction to SEM</i>	147
6.5.2	<i>Aims</i>	148
6.5.3	<i>Procedure</i>	148
6.5.4	<i>Results and conclusions</i>	149
CHAPTER 7 - SUGGESTIONS FOR POSSIBLE TREATMENTS TO IMAGE-REINTEGRATE AIRBRUSH PAINTINGS		
7.1	INTRODUCTION	152
7.2	THE PREPARATION OF A MOCK-UP PAINTING	152
7.2.1	<i>The Use of Interventive Imitative Image Reintegration</i>	157
7.2.2	<i>The Use of Printed Infills for Image Reintegration</i>	159
7.2.2.1	Problems found with this method	161
7.2.3	<i>The Use of the Airbrush for Image Reintegration</i>	163
7.2.4	<i>The Use of Light Projectors for Virtual Image Reintegration</i>	164
7.2.5	<i>The Main Types of Projectors Currently Marketed</i>	164
7.2.5.1	CRT Projectors	165
7.2.5.2	LCD Projectors	165
7.2.5.3	DLP Projectors	167
7.2.5.4	LCOS Projectors	170
7.2.5.5	Specifications to look for in a Pico projector for virtual image-reintegration:	171
7.2.6	<i>The Use of a DLP Pico-Projector for the Image-Reintegration of the Mock-Up Painting</i>	174
7.2.7	<i>Conclusion</i>	178
CHAPTER 8: DISCUSSION, CONCLUSIONS AND RECOMMENDATIONS		
8.1	DISCUSSION	179
8.2	CONCLUSIONS	179
8.3	CONTRIBUTION TO KNOWLEDGE	180
8.4	RECOMMENDATIONS	181
LIST OF REFERENCES		
APPENDICES		
A.1	APPENDIX A: QUESTIONNAIRES	- 1 -
A.1.1	<i>Questionnaire 1: A Survey on the Conservation of Airbrush Easel Paintings</i>	- 1 -
A.1.2	<i>Tables and Charts of the Responses to Questionnaire 1</i>	- 37 -
A.1.2.1	<i>The demographic profile of respondents:</i>	- 38 -
A.1.2.2	<i>Career-related questions:</i>	- 43 -
A.1.2.3	<i>Attitudinal questions:</i>	- 44 -
A.1.2.4	<i>Branching Question:</i>	- 46 -
A.1.2.5	<i>Questions only related to respondents with direct experience in airbrush easel paintings:</i>	- 47 -

A.1.2.6	<i>Open-ended questions:</i>	- 54 -
A.1.2.7	<i>Verbatim responses to Questionnaire 1:</i>	- 56 -
A.1.3	<i>Questionnaire 2: A Survey on Airbrush Easel Painting in the Context of Fine Art</i>	- 59 -
A.1.4	<i>Verbatim responses to the questionnaire aimed at fine artists</i>	- 105 -
A.2	APPENDIX B: ACCELERATED LIGHT AGEING TEST TABLES AND GRAPHS	- 107 -
A.2.1	<i>Accelerated Light Ageing Test no. 1</i>	- 107 -
A.2.2	<i>Accelerated Light Ageing Test no. 2</i>	- 116 -
A.3	APPENDIX C: SEM IMAGES (ALL IMAGES LISTED ARE MAGNIFIED AT 1000x).....	- 125 -
A.3.1	<i>SEM Imaging (Samples Group 1): a. Airbrushed Aged vs. paint-brushed aged</i>	- 125 -
A.3.2	<i>SEM Imaging (Samples Group 1): b. Airbrushed non-aged vs. paint-brushed non-aged</i>	- 126 -
A.3.3	<i>SEM Imaging (Samples Group 2): a. Airbrushed Aged vs. paint-brushed aged</i>	- 128 -
A.3.4	<i>SEM Imaging (Samples Group 2): b. Airbrushed non-aged vs. paint-brushed non-aged</i>	- 129 -

List of Tables

TABLE 1: DATES OF INTRODUCTION OF PRINCIPAL BINDERS IN MODERN PAINTS (T LEARNER, 2007, P. 4).	53
TABLE 2: TRADE NAMED RAW MATERIALS OF ACRYLIC RESIN PRODUCTS FOR WATER-BASED PAINTS BY RÖHM & HASS (FLICK, 1994, P. 458)	55
TABLE 3: LIST OF SAMPLES	124
TABLE 4: THIS TABLE INCLUDES ALL FTIR SPECTROGRAMS AND PY-GC-MS PYROGRAMS OF THE FOUR SAMPLES ANALYSED; RAPHAEL ACRYLIC GESSO, GOLDEN PRIMARY YELLOW, GOLDEN PRIMARY MAGENTA AND GOLDEN PRIMARY CYAN RESPECTIVELY.....	128
TABLE 5: LIST OF CONCLUSIONS.....	137
TABLE 6: RELATIONSHIP BETWEEN HOURS OF EXPOSURE TO ARTIFICIAL SIMULATED INDOOR SUNLIGHT AND EQUIVALENT YEARS OF EXPOSURE TO MUSEUM LIGHTING ACCORDING TO SMITH(2007, P. 238), BASED ON THE FACTORS: *IRRADIANCE = 74,425 LUX AND ** RECIPROCITY ASSUMED, 2950 HOURS/YEAR AT 150 LUX.	142
TABLE 7: COMPARISON BETWEEN AIRBRUSHED AND PAINT-BRUSHED SAMPLES, IN TERMS OF THEIR TOPOGRAPHICAL FEATURES, SHOWS THAT PAINT-BRUSHED SAMPLES’ SURFACES ARE MORE ‘ROUGH’ THAN THOSE OF AIRBRUSHED SAMPLES. ALL THESE SEM IMAGES ARE RECORDED AT 1,000X MAGNIFICATION. .	149
TABLE 8: PHOTOGRAPHS THE AGED SAMPLES COMPARED TO THE NON-AGED REFERENCE SAMPLES THAT ARE CORRESPONDING TO THEM IN COLOUR AND TECHNIQUE OF PAINT APPLICATION.....	150
TABLE 9: DISTRIBUTION OF RESPONDENTS BY GENDER	38 -
TABLE 10: DISTRIBUTION OF RESPONDENTS BY AGE GROUP	39 -
TABLE 11: DISTRIBUTION OF RESPONDENTS BY HIGHEST LEVEL OF EDUCATION.....	40 -
TABLE 12: DISTRIBUTION OF RESPONDENTS BY COUNTRY OF RESIDENCE.....	41 -
TABLE 13: DISTRIBUTION OF RESPONDENTS BY GENDER AND AGE GROUP.....	42 -
TABLE 14: DISTRIBUTION OF RESPONDENTS ACCORDING TO THEIR DIRECT EXPERIENCE WITH AIRBRUSH PAINTINGS	47 -
TABLE 15: DISTRIBUTION OF RESPONDENTS ACCORDING TO THEIR OPINION WHETHER CONSERVATION PROBLEMS IN AIRBRUSH PAINTINGS ARE DIFFERENT FROM THOSE IN PAINTINGS EXECUTED WITH OTHER PAINT APPLICATION TYPES.	48 -
TABLE 16: DISTRIBUTION OF RESPONDENTS ACCORDING TO THEIR EXPERIENCE WITH THE CONSERVATION TREATMENTS AND PROCEDURES THAT AIRBRUSH PAINTINGS OFTEN REQUIRE. PLEASE NOTE THAT MULTIPLE ANSWERS PER PARTICIPANT EXIST. PERCENTAGES ADDED EXCEED 100 SINCE A PARTICIPANT MAY SELECT MORE THAN ONE ANSWER FOR THIS QUESTION.	48 -
TABLE 17: DISTRIBUTION OF RESPONDENTS ACCORDING TO THEIR EXPERIENCE WITH THE THICKNESS OF THE GROUND LAYER IN AIRBRUSH PAINTINGS COMPARING TO OTHER TYPES OF PAINTINGS.....	49 -
TABLE 18: DISTRIBUTION OF RESPONDENTS ACCORDING TO THEIR EXPERIENCE WITH THE THICKNESS OF THE PAINT FILM IN AIRBRUSH PAINTINGS COMPARING TO OTHER TYPES OF PAINTINGS	50 -
TABLE 19: DISTRIBUTION OF RESPONDENTS ACCORDING TO THEIR EXPERIENCE WITH THE DETERIORATION PROBLEMS THAT THEY MIGHT HAVE ENCOUNTERED IN THE PAINT FILM IN AIRBRUSH PAINTINGS.....	51 -
TABLE 20: DISTRIBUTION OF RESPONDENTS ACCORDING TO WHICH OF THE PAINT MEDIUMS WAS DOMINANTLY EMPLOYED IN AIRBRUSH PAINTINGS THEY ENCOUNTERED.....	52 -
TABLE 21: DISTRIBUTION OF RESPONDENTS ACCORDING TO HOW OFTEN THEY ENCOUNTERED AN EXISTENCE OF VARNISH LAYER IN AIRBRUSH PAINTINGS	53 -
TABLE 22: THE TABLE SHOWS THE VERBATIM RESPONSES TO THE OPEN ENDED QUESTIONS NO. 20, 25 AND 29 OF THE QUESTIONNAIRE AIMED AT ART CONSERVATORS	56 -
TABLE 23: COMPARISON BETWEEN THE CHANGES IN COLOUR VALUES (Δ) OF AIRBRUSHED AND PAINT-BRUSHED PRIMARY CYAN SAMPLES	107 -

TABLE 24: FURTHER DETAILED DATA OF THE NUMERICAL COLOUR VALUES OF THE NON-AGED COMPARED TO ARTIFICIALLY LIGHT AGED PAINT LAYERS OF BOTH AIRBRUSHED AND PAINT-BRUSHED CYAN SAMPLES. -	107
-	
TABLE 25: A COMPARISON BETWEEN THE CHANGES IN THE VALUES (Δ) OF AIRBRUSHED AND PAINT-BRUSHED PRIMARY MAGENTA SAMPLES	110 -
TABLE 26: FURTHER DETAILED DATA OF THE NUMERICAL COLOUR VALUES OF THE NON-AGED COMPARED TO ARTIFICIALLY LIGHT AGED PAINT LAYERS OF BOTH AIRBRUSHED AND PAINT-BRUSHED MAGENTA SAMPLES. -	110 -
TABLE 27: A COMPARISON BETWEEN THE CHANGES IN THE VALUES (Δ) OF AIRBRUSHED AND PAINT-BRUSHED PRIMARY YELLOW SAMPLES	113 -
TABLE 28: FURTHER DETAILED DATA OF THE NUMERICAL COLOUR VALUES OF THE NON-AGED COMPARED TO ARTIFICIALLY LIGHT AGED PAINT LAYERS OF BOTH AIRBRUSHED AND PAINT-BRUSHED YELLOW SAMPLES.	113 -
TABLE 29: COMPARISON BETWEEN THE CHANGES IN THE VALUES (Δ) OF AIRBRUSHED AND PAINT-BRUSHED PRIMARY CYAN SAMPLES (ACCELERATED LIGHT AGEING TEST NO.2).....	116 -
TABLE 30: FURTHER DETAILED DATA OF THE NUMERICAL COLOUR VALUES OF THE NON-AGED COMPARED TO ARTIFICIALLY LIGHT AGED PAINT LAYERS OF BOTH AIRBRUSHED AND PAINT-BRUSHED CYAN SAMPLES (ACCELERATED LIGHT AGEING TEST NO.2).....	116 -
TABLE 31: COMPARISON BETWEEN THE CHANGES IN THE VALUES (Δ) OF AIRBRUSHED AND PAINT-BRUSHED PRIMARY MAGENTA SAMPLES (ACCELERATED LIGHT AGEING TEST NO.2).....	119 -
TABLE 32: FURTHER DETAILED DATA OF THE NUMERICAL COLOUR VALUES OF THE NON-AGED COMPARED TO ARTIFICIALLY LIGHT AGED PAINT LAYERS OF BOTH AIRBRUSHED AND PAINT-BRUSHED MAGENTA SAMPLES (ACCELERATED LIGHT AGEING TEST NO.2).....	119 -
TABLE 33: COMPARISON BETWEEN THE CHANGES IN THE VALUES (Δ) OF AIRBRUSHED AND PAINT-BRUSHED PRIMARY YELLOW SAMPLES (ACCELERATED LIGHT AGEING TEST NO.2)	122 -
TABLE 34: FURTHER DETAILED DATA OF THE NUMERICAL COLOUR VALUES OF THE NON-AGED COMPARED TO ARTIFICIALLY LIGHT AGED PAINT LAYERS OF BOTH AIRBRUSHED AND PAINT-BRUSHED YELLOW SAMPLES (ACCELERATED LIGHT AGEING TEST NO.2).....	122 -

List of Figures

FIGURE 1: TYPES OF AIR COMPRESSORS FROM THE EARLY 20 TH CENTURY. TOP LEFT: ‘LIQUID CARBONIC GAS OUTFIT’, TOP RIGHT: ‘HAND OPERATED PUMP’, BOTTOM: ‘TWO TYPES OF ELECTRICALLY CONNECTED PUMPS’ (STINE, 1920, P. 21)	10
FIGURE 2: A DRAWING FROM THE LATE 19 TH CENTURY OF A MAN WORKING WITH AN AIRBRUSH POWERED BY A MANUAL AIR PUMP WITH A FOOT PEDAL (AIR BRUSH MANUFACTURING COMPANY ROCKFORD, 1887, P. 8) 10	
FIGURE 3: A PHOTOGRAPH FROM THE EARLY 20 TH CENTURY OF AN ILLUSTRATOR WHILE USING AN AIRBRUSH POWERED BY AN EARLY TYPE OF ELECTRICAL AIR COMPRESSOR (STINE, 1920, P. 148)	11
FIGURE 4: ILLUSTRATION OF STANLEY’S MODEL OF AN ‘ATOMIZER’. THIS IS CONSIDERED AS THE FIRST TYPE OF THE AIRBRUSH	12
FIGURE 5: (LEFT) A PHOTOGRAPH OF ABNER PEELER. (RIGHT) SELF-PORTRAIT COPIED BY PEELER FROM HIS OWN PHOTOGRAPH. THE SPRAY-PAINTING WAS EXECUTED FULLY WITH PEELER’S PAINT DISTRIBUTER ONLY A MONTH AFTER ITS INVENTION (PEELER, 1882).....	13
FIGURE 6: PEELER/WALKUP PAINT-DISTRIBUTER PATENTS. FROM LEFT TO RIGHT; PEELER’S ORIGINAL MODEL (1882), WALKUP’S INITIAL IMPROVEMENTS (1883), WALKUP’S FURTHER IMPROVEMENTS (1884), WALKUP’S FINAL VERSION TO BE READY FOR THE MARKET. THE FINAL VERSIONS OF THE DEVICE WERE IMPROVED TO BECOME MORE PORTABLE. THE PORTABILITY WAS NOT ONLY ABOUT THE SIZE OF THE AIRBRUSH, BUT MORE IMPORTANTLY CONTROLLING IT BY ONE HAND THROUGH ONE TRIGGER. (1885)	14

FIGURE 7: ONE OF THE EARLIEST PROTOTYPES OF THE AIRBRUSH (LEFT) AND A DRAWING SHOWING HOW TO HOLD AND CONTROL THE DEVICE (RIGHT), AS ADVERTISED IN A COMPANY’S BOOKLET (AIR BRUSH MANUFACTURING COMPANY (ROCKFORD, 1887, PP. 10, 28). DESPITE ITS PRINCIPLE IS THE SAME AS THAT OF LATER AIRBRUSH PROTOTYPES MADE BY OTHER COMPANIES, THE DESIGN IS COMPLETELY DIFFERENT FROM THE AIRBRUSH AS WE KNOW IT TODAY.	14
FIGURE 8: THE FIRST ADVERTISEMENT PUBLISHED BY THE AIR BRUSH MANUFACTURING COMPANY IN <i>THE PHILADELPHIA PHOTOGRAPHER</i> NEWSLETTER IN NOVEMBER 1883 SHOWS THE EASE WITH WHICH PAINT CAN BE APPLIED USING JUST ONE HAND (THE PHILADELPHIA PHOTOGRAPHER, 1883).....	16
FIGURE 9: PRICE LIST OF PRODUCTS, ACCESSORIES AND SPARE PARTS MARKETED BY THE AIR BRUSH MFG. CO. AND PUBLISHED IN <i>THE AIR BRUSH JOURNAL</i> (BENNETT, 1892).....	18
FIGURE 10: A PATENTED BURDICK’S AIR BRUSH (BURDICK, 1892)	21
FIGURE 11: AN EARLY AEROGRAPH MODEL BY CHARLES BURDICK (COURTESY OF ANDY PENALUNA)	22
FIGURE 12: AN ADVERTISEMENT OF THE AEROGRAPH COMPANY IN ENGLAND FOUNDED BY CHARLES BURDICK (STINE, 1920, P. 146).....	24
FIGURE 13: AN ADVERTISEMENT BY A PHOTOGRAPHY STUDIO CLAIMED THAT THEY WERE THE ONLY IN THE CITY “USING THAT MAGIC TOOL, THE AIR BRUSH”. THIS ADVERTISEMENT WAS PUBLISHED IN <i>THE HERALD</i> OF LOS ANGELES (1893, CHRONICLING AMERICA - LIBRARY OF CONGRESS DIGITAL ARCHIVE, P. 8).....	27
FIGURE 14: USED AIR BRUSH WANTED; AN ADVERTISEMENT PUBLISHED IN <i>ST. PAUL DAILY GLOBE</i> , MINNESOTA (1887A, CHRONICLING AMERICA - LIBRARY OF CONGRESS DIGITAL ARCHIVE, P. 8)	27
FIGURE 15: AIR BRUSH ARTIST WANTED; AN ADVERTISEMENT PUBLISHED IN <i>KANSAS CITY JOURNAL</i> (1899, CHRONICLING AMERICA - LIBRARY OF CONGRESS DIGITAL ARCHIVE, P. 18).....	28
FIGURE 16: A 1949 ADVERTISEMENT BY THE AEROGRAPH CO. LTD. CLAIMS: “AEROGRAPH AIR BRUSHES ARE USED ALL OVER THE WORLD.”	29
FIGURE 17: AN ADVERTISEMENT FOR THE ILLINOIS ART SCHOOL (BELOIT COLLEGE, 1892, P. 3)	32
FIGURE 18: AN ADVERTISEMENT OF THE ILLINOIS ART SCHOOL (THE SUNDAY SCHOOL TIMES, 1890, P. 220).....	34
FIGURE 19: A PINUP ILLUSTRATION BY GEORGE PETTY (LEFT) AND A PINUP ILLUSTRATION BY ALBERTO VARGAS (RIGHT).....	40
FIGURE 20: “DANIEL VLADIMIR BARANOFF-ROSSINI. COPRICCIO MUSICALE (CIRCUS). 1913, GLUE-BASED PAINT, OIL AND PENCIL ON CANVAS. 130.4 X 163.1 CM. HIRSHHORN MUSEUM AND SCULPTURE GARDEN, SMITHSONIAN INSTITUTION, WASHINGTON, D.C.... BARANOFF-ROSSINÉ CREATED THE IMPRESSION OF MOVEMENT AND THEATRICAL LIGHTING BY SPRAYING POINT OVER STENCILS.” (KIRSH AND LEVENSON, 2000, P. 136).....	42
FIGURE 21: MAN RAY, <i>ADMIRATION OF THE ORCHESTRELLE FOR THE CINEMATOGRAF</i> , 1919, AIRBRUSHED INK AND GOUACHE, INK, AND PENCIL ON GREY PAPER (66 X 54.6 CM). THE MUSEUM OF MODERN ART (MOMA)	44
FIGURE 22: PAUL KLEE, <i>VIEW OF A LANDSCAPE</i> , 1926. AIRBRUSHED GOUACHE ON PAPER MOUNTED ON LIGHT CARDBOARD, 29.8 X 46.3 CM. PHILADELPHIA MUSEUM OF ART.....	46
FIGURE 23: WASSILY KANDINSKY, <i>HORIZONTAL BLUE</i> , 1929. AIRBRUSHED WATERCOLOUR, GOUACHE AND BLUE INK ON PAPER, 24.2 X 31.7 CM. THE HILLA VON REBAY FOUNDATION	46
FIGURE 24: SIQUEIROS GIVING A PRESENTATION OF THE USE OF SPRAY GUN ON A MURAL PAINTING (RANDEE SILV, 2013).....	48
FIGURE 25: CARTOON BY BOWERS, PUBLISHED IN <i>BOSTON DAILY GLOBE</i> , 21 MAY 1922 (PROQUEST HISTORICAL NEWSPAPERS: BOSTON GLOBE 1872 – 1979, PG. C4)	50
FIGURE 26: A MID-20 TH CENTURY COLOUR CHART OF MAGNA PAINTS BY BOCOUR (MORRISLOUIS.ORG).....	57
FIGURE 27: JULES OLITSKI, <i>INSTANT LOVELAND</i> (1968), 2946 X 6457 MM, AIRBRUSHED ACRYLIC PAINTS ON CANVAS (COURTESY OF TATE).....	62
FIGURE 28: DAN CHRISTENSEN, <i>CONJUGATE</i> (1967), AIRBRUSHED ACRYLIC ON CANVAS 48X48” (DANCHRISTENSEN.COM).....	62
FIGURE 29: PETER SEDGLEY, <i>COLOUR CYCLE III</i> (1970), AIRBRUSHED ACRYLIC PAINT ON CANVAS, 1841 X 1829 MM (TATE COLLECTION).....	63

FIGURE 30: BARRIE COOK, <i>PAINTING</i> (1970), AIRBRUSHED ACRYLIC PAINT ON CANVAS, 2440 X 3047 MM (TATE COLLECTION)	64
FIGURE 31: JAMES ROSENQUIST, <i>MARILYN MONROE, I</i> (1962), OIL AND SPRAY ENAMEL ON CANVAS, 236.2 X 183.3 CM	65
FIGURE 32: PETER PHILLIPS, <i>MOSAIKBILD/DISPLACEMENTS</i> (1976), AIRBRUSHED ACRYLIC ON CANVAS, 220 X 230 CM, PRIVATE COLLECTION (PETERPHILLIPS.COM)	65
FIGURE 33: CHUCK CLOSE WITH APPLYING PLASTER TO HIS WIFE, FOR AN ART PROJECT, AND STANDING IN FRONT OF HIS 21-FOOT-LONG <i>BIG NUDE</i> (1967), IN THE BACKGROUND HIS <i>BIG SELF-PORTRAIT</i> (1967-68), (CLOSE <i>ET AL.</i> , 1998, P. 205). THOSE PAINTINGS WERE THE FIRST PHOTOREALIST PAINTINGS BY CHUCK CLOSE THAT HE EXECUTED WITH AIRBRUSH.....	67
FIGURE 34: DON EDDY, <i>PRIVATE PARKING X</i> , ACRYLIC ON CANVAS, 66 X 95”, PRIVATE COLLECTION (KUSPIT, 2002, P. 16).....	67
FIGURE 35: AUDREY FLACK, <i>MARILYN</i> , (1977) OIL OVER ACRYLIC ON CANVAS 20 X 20” (AUDREYFLACK.COM)...	68
FIGURE 36: BEN SCHONZEIT, <i>BLUISH PLUMS</i> , 2010, ACRYLIC ON CANVAS, 33 X 33” (MEISELGALLERY.COM)	68
FIGURE 37: CESAR SANTANDER USES AN AIRBRUSH DURING WORKING ON ONE OF HIS PAINTINGS (CESARSANTANDER.COM).....	69
FIGURE 38: RUDY SPARKUHL, <i>ROOTS</i> , (2005) ACRYLIC ON CANVAS, 20 X 16” (SYMPATICO.CA/GUNTHER.SPARKUHL).....	69
FIGURE 39: JUAN COSSIO, <i>IMPULSO</i> , (2011) 185 X 75CM ACRYLIC ON CANVAS (JUANCOSIO.COM).....	70
FIGURE 40: HUBERT DE LARTIGUE, <i>W & W</i> , (2010) ACRYLIC ON CANVAS, 130 X 89CM (HUBERTDELARTIGUE.COM)	70
FIGURE 41: SIMON HENNESSEY, <i>WESTMINSTER</i> , (2012) ACRYLIC INKS ON CANVAS, 61 X138 CM, (SIMONHENNESSEY.COM).....	70
FIGURE 42: RIGHT: AUDREY FLACK PUTTING THE FINISHING TOUCHES ON A PORTRAIT OF THE FORMER EGYPTIAN PRESIDENT ANWAR EL-SADAT WITH AN AIRBRUSH, 1978. LEFT: “EL-SADAT RECEIVES THE PORTRAIT AS A GIFT FROM A GROUP OF AMERICAN BUSINESSMEN FOR HIS EFFORTS FOR PEACE,” ACCORDING TO THE CAPTION IN ARABIC. THE PICTURE IS COURTESY OF ARCHIVES OF AMERICAN ART, SMITHSONIAN INSTITUTION. THE PAINTING IS COURTESY OF EL-SADAT MUSEUM, EGYPT.	72
FIGURE 43: JOHN SALT, <i>IRONMONGERS</i> (1981), SIGN-WRITERS’ PAINT ON CANVAS, 106.80 X 161.30 CM (COURTESY OF NATIONAL GALLERIES OF SCOTLAND)	73
FIGURE 44: JOHN SALT, <i>UNTITLED</i> (1975), 115 X 170.9 CM. ©JOHN SALT ©BIRMINGHAM MUSEUMS TRUST.....	74
FIGURE 45: SIMON HENNESSEY WORKING ON ONE OF HIS PAINTINGS (COURTESY OF SIMON HENNESSEY)	74
FIGURE 46: PART OF THE GROUP SHOW ‘GO WITH THE FLOW, JULY 2014 (THEHOLENYC.COM)	75
FIGURE 47: THIS DIAGRAM SHOWS A PROPOSED HIERARCHICAL RELATIONSHIP AMONG A NUMBER OF COLLECTIVE AND SUB-COLLECTIVE TERMS THAT REPRESENT APPROACHES TO THE AESTHETIC RESTORATION OF TWO-DIMENSIONAL WORKS OF ART. THIS IS AN ATTEMPT TO ACHIEVE A MORE PROPER AND MEANINGFUL CLASSIFICATION OF SUCH TERMS OF WHICH SOME ARE FOUND TO HAVE BEEN USED INTERCHANGEABLY IN LITERATURE. THIS DIAGRAM IS ALSO INTENDED TO VISUALLY DEMONSTRATE THE DEMARCATION THAT CAN BE DRAWN AMONG THESE TERMS IN ORDER TO MAINTAIN THE APPROACH THAT EACH TERM REPRESENTS. IT WOULD BE IMPORTANT TO NOTE THAT APPROACHES THAT LIE OUT OF THE SCOPE OF THE PRINCIPLE OF MINIMAL INTERVENTION – NOTABLY ‘OVERPAINTING’ – ARE NOT REPRESENTED IN THIS HIERARCHAL TERMINOLOGY. SUCH APPROACHES ARE GENERALLY ABANDONED IN MODERN ART CONSERVATION.....	81
FIGURE 48: BARNETT NEWMAN, <i>CATHEDRA</i> , (1951), 2.43M X 5.43M, OIL AND MAGNA ON CANVAS (COURTESY OF STEDELIJK MUSEUM AMSTERDAM)	88
FIGURE 49: CONSERVATORS INSTALL <i>PANEL ONE</i> OF THE <i>HARVARD MURALS</i> , HOLYOKE CENTER, JANUARY 1963. (ELIZABETH H. JONES/PRESIDENT AND FELLOWS OF HARVARD COLLEGE) (SHEA, 2014B)	92
FIGURE 50: MARK ROTHKO’S <i>HARVARD MURALS</i> — <i>PANEL ONE</i> , <i>PANEL TWO</i> AND <i>PANEL THREE</i> — HOLYOKE CENTER, JANUARY 1965. (COURTESY OF HARVARD UNIVERSITY ARCHIVES) (SHEA, 2014B)	93
FIGURE 51: <i>PANEL FIVE</i> OF ROTHKO’S <i>HARVARD MURALS</i> HANGS IN HOLYOKE CENTER IN JANUARY 1968. (COURTESY OF HARVARD UNIVERSITY ARCHIVES) (SHEA, 2014A).....	93

FIGURE 52: DIFFERENT VERSIONS OF THE SAME PAINTING. LEFT: THE ROTHKO PAINTING IN ITS FADED FORM. MIDDLE: THE EKTACHROME PHOTO THAT HAD TURNED TOO RED WITH TIME. RIGHT: THE PAINTING COLOR-CORRECTED BACK TO THE ORIGINAL (EVERTS, 2011).....	98
FIGURE 53: CONSERVATION SCIENTIST JENS STENGER HOLDS A WHITE BOARD DEMONSTRATING THE NONINVASIVE DIGITAL PROJECTION OF ONE OF THE DAMAGED MARK ROTHKO PAINTINGS. (JESSE COSTA/WBUR) (SHEA, 2014B).....	98
FIGURE 54: THE DIGITAL IMAGING SOFTWARE AND TOOLS USED TO CALIBRATE THE COLOR CORRECTIONS ONTO THE DAMAGED ROTHKO PAINTINGS. (JESSE COSTA/WBUR) (SHEA, 2014B).....	99
FIGURE 55: A SIMPLIFIED WORKFLOW SCHEME PRESENTED BY (CUELLAR <i>ET AL.</i> , 2011, P. 4) OF THE CAMERA-PROJECTOR SYSTEM USED FOR THE NON-INTERVENTIVE RETOUCHING OF ROTHKO'S <i>HARVARD MURALS</i>	99
FIGURE 56: THE 'VIRTUAL RESTORATION' PROJECT FOR THE BROEMSERHOF MURALS BY MICHAELA JANKE: LEFT ASSESSING THE TOPOGRAPHY OF AN AREA OF LOSS IN THE CEILING PAINTING BY MEANS OF A HIGH-TECH SYSTEM PROVIDED BY COOLUX GMBH, RIGHT: THE SAME AREA OF LOSS EVENTUALLY 'RETOUCHED' WITH A PROJECTED DIGITAL IMAGE (PHOTOS BY MICHAELA JANKE).....	99
FIGURE 57: A DIAGRAM OF THE DESIGN AND SEQUENCE OF THE SURVEY AIMED AT EASEL PAINTING CONSERVATORS AS A PART OF THE RESEARCH IN THE FORM OF A QUESTIONNAIRE.....	109
FIGURE 58: FTIR SPECTRUM OF SAMPLE 1 VARNISH SAMPLE FROM DUNHAM-M.....	128
FIGURE 59: FTIR SPECTRUM OF CHALK.....	129
FIGURE 60: PYROGRAM OF RAPHAEL 'ACRYLIC GESSO', WHITE.....	130
FIGURE 61: DETAIL OF , PYROGRAM OF RAPHAEL 'ACRYLIC GESSO', WHITE.....	131
FIGURE 62: FTIR SPECTRUM OF SAMPLE 2, GOLDEN COMPANY PRIMARY YELLOW.....	132
FIGURE 63: FTIR SPECTRUM OF PARALOID B72; AN ACRYLATE /METHACRYLATE CO-POLYMER.....	132
FIGURE 64: FTIR SPECTRUM OF PY17.....	133
FIGURE 65: PY-GC-MS PYROGRAM OF SAMPLE 2, GOLDEN COMPANY PRIMARY YELLOW.....	133
FIGURE 66: PY-GC-MS PYROGRAM OF SAMPLE 2, GOLDEN COMPANY PRIMARY YELLOW, DETAIL 2-15 MINUTES.....	134
FIGURE 67: FTIR SPECTRUM OF SAMPLE 2, GOLDEN COMPANY PRIMARY MAGENTA.....	134
FIGURE 68: FTIR SPECTRUM OF PV19.....	135
FIGURE 69: PY-GC-MS PYROGRAM OF SAMPLE 3, GOLDEN COMPANY PRIMARY MAGENTA.....	135
FIGURE 70: FTIR SPECTRUM OF SAMPLE 4, GOLDEN COMPANY PRIMARY CYAN.....	136
FIGURE 71: FTIR SPECTRUM OF PB15.....	136
FIGURE 72: AN ILLUSTRATION OF A THREE WAY AXIS GRAPH OF $L^*A^*B^*$ WHICH REFLECTS THE METHOD USED BY THE KONICA MINOLTA CM2600D REFLECTED LIGHT SPECTROPHOTOMETER TO DESCRIBE THE COLOUR NUMERICALLY.....	143
FIGURE 73: LEFT: <i>JOHN</i> (1971-72) BY CHUCK CLOSE, ACRYLIC ON CANVAS, 100 X 90 INCH. MIDDLE: THE PLACE OF THE DETAIL FROM <i>JOHN</i> USED AS A REFERENCE FOR THE MOCK-UP PAINTING. RIGHT: LARGER VIEW OF THE REFERENCE DETAIL FROM <i>JOHN</i>	153
FIGURE 74: A MOCK-UP PAINTING CARRIED OUT BY THE RESEARCHER FOLLOWING A DETAIL FROM CHUCK CLOSE'S <i>JOHN</i> , PHOTOGRAPHED UNDER REFLECTED LIGHT.....	154
FIGURE 75: CHUCK CLOSE IN HIS STUDIO WORKING IN A MID-STAGE ON <i>MARK</i> . THIS PHOTOGRAPH SHOWS CLOSE'S COLOUR SEPARATION TECHNIQUE REPRESENTED BY THE MONOCHROMATIC IMAGES PUT ON AN EASEL STANDS BY HIS LEFT SIDE. AT THAT STAGE THE CYAN/MAGENTA SUBSEQUENT LAYERS ARE STILL VISIBLE UNDER <i>MARK</i> 'S LEFT EYE.....	154
FIGURE 76: COLOUR-SEPARATION OF <i>JOHN</i> DETAIL, DONE DIGITALLY AND THEN USED AS GUIDANCE FOR THE PREPARATION OF THE MOCK-UP PAINTING APPEARS IN FIGURE 2.....	155
FIGURE 77: THE MOCK-UP PAINTING OF A DETAIL FROM <i>JOHN</i> (AFTER CHUCK CLOSE), PHOTOGRAPHED UNDER RAKING LIGHT. THE TEXTURE APPEARS EVEN ACROSS THE SURFACE.....	155
FIGURE 78: THIS CLOSE-UP TO THE MOCK-UP PAINTING UNDER RAKING LIGHT SHOWS FURTHER DETAIL OF THE SURFACE. THE VERY LOW THICKNESS OF THE AIRBRUSHED PAINT LAYER IS OBVIOUS AS IT APPEARS AS IF EMBEDDED INTO THE TEXTURE OF THE CANVAS.	156

FIGURE 79: THE MOCK-UP PAINTING OF A DETAIL FROM <i>JOHN</i> (AFTER CHUCK CLOSE), PHOTOGRAPHED UNDER UV IRRADIATION. THE LIGHT TONES INDICATE LESS PAINT APPLIED.....	156
FIGURE 80: THIS AREA OF THE MOCK-UP PAINTING WAS DELIBERATELY DAMAGED BY SCRAPING IT USING SANDPAPER.....	157
FIGURE 81: IMAGE TAKEN DURING THE PROCESS OF A CONVENTIONAL IMITATIVE RETOUCHING OF A FABRICATED LOSS IN THE MOCK-UP PAINTING	158
FIGURE 82: (1): THE ORIGINAL LOSS MADE IN THE MOCK-UP PAINTING, (2, 3 AND 4): EXAMPLES OF ATTEMPTS OF INTERVENTIVE IMAGE REINTEGRATION CARRIED OUT ON THE SAME LOSS. THE ATTEMPTS WERE UNSUCCESSFUL BECAUSE THE ULTRA-FINE DOTS OF THE SPRAYED PAINTS SURROUNDING THE LOSS COULD NOT BE MIMICKED IN SPITE OF THE USE OF A FINE SPOOTER PAINTBRUSH	158
FIGURE 83: A CLOSE-UP IMAGE SHOWS GREATER DETAIL OF THE AIRBRUSHED SURFACE OF THE MOCK-UP PAINTING. THE LEFT SIDE OF THE IMAGE SHOWS THE DETAILED NETWORK OF ULTRA-FINE PAINT DOTS APPLIED BY THE AIRBRUSH. THE RIGHT SIDE OF THE IMAGE SHOWS DETAIL OF THE LOSS OF THE ORIGINAL PAINT LAYER THAT WAS DELIBERATELY MADE FOR TESTING.....	159
FIGURE 84: RICHARD HAMILTON, <i>HOMMAGE À CHRYSLER CORP.</i> , (1957), OIL, METAL FOIL AND COLLAGE ON WOOD, 1220 X 810 MM (COURTESY OF THE TATE GALLERY) “PAINTING AFTER TREATMENT WITH THE ARTIST’S GUIDE PRINT”	160
FIGURE 85: PEELING OFF ‘TEMPORARY INKJET TATTOO PAPER’	161
FIGURE 86: THIS IS THE OUTCOME OF THE FIRST IMAGE REINTEGRATION TEST THAT WAS DONE USING THE ‘TEMPORARY INKJET TATTOO PAPER’, ALTHOUGH THE PRELIMINARY OUTCOME WAS SOMEWHAT PROMISING BUT NOT SATISFACTORY. THIS PRINTED INFILL MATCHES THE SURROUNDING AREA ONLY IN CERTAIN LIGHT CONDITIONS.....	162
FIGURE 87: MORE AREAS OF LOSS WERE CREATED ON THE MOCK-UP PAINTING TO FACILITATE IMAGE REINTEGRATION TESTS USING PRINTED INFILLS. HOWEVER, NONE OF THOSE TESTS LED TO SATISFACTORY OUTCOMES. THE PRINTED INFILL AT THE BOTTOM RIGHT AS VIEWED IN THIS PHOTOGRAPH IS RELATIVELY THE BEST ACHIEVED OUTCOME IN TERMS OF COLOUR MATCHING; HOWEVER IT WAS GREATLY DIFFICULT TO FIND A SUITABLE METHOD TO CREATE A CUT SEAMLESS WITH THE PERIPHERIES OF THE AREA OF LOSS.....	163
FIGURE 88: A CRT PROJECTOR DURING INSTALLATION (KENNIS RUSSELL, 2014)	165
FIGURE 89: SCHEMATIC DRAWING OF LCD PROJECTOR COMPONENTS (3LCD.COM).....	167
FIGURE 90: EPSON® POWERLITE 1761W WXGA 3LCD PROJECTOR (MARK WATSON, 2013)	167
FIGURE 91: SCHEMATIC DRAWING OF DLP PROJECTOR COMPONENTS (TEXAS INSTRUMENTS: TI.COM)	168
FIGURE 92: AN EXAMPLE OF A PICO PROJECTOR (PROULX, 2012, P. 386)	170
FIGURE 93: A TILTED AND/OR ANGLED PROJECTOR CAUSED DISTORTIONS IN THE PROJECTED IMAGE. THIS PROBLEM IS KNOWN AS ‘KEYSTONING’. IN ORDER TO OVERCOME THIS PROBLEM, MANY OF THE MODERN PROJECTORS CAN AUTOMATICALLY CORRECT SUCH DISTORTIONS.....	173
FIGURE 94: THE ACER K130 PROJECTOR USED FOR THE VIRTUAL IMAGE-REINTEGRATION EXPERIMENTAL CARRIED OUT FOR THE MOCK-UP PAINTING. FOR THAT PURPOSE, THE PROJECTOR WAS MOUNTED ON A TRIPOD TO FACILITATE THE NECESSARY ADJUSTMENTS OF THE IMAGE PROJECTED.....	174
FIGURE 95: (LEFT) THE RIGHT PART OF THE MOCK-PAINTING WHERE THE AREA OF LOSS IS PRESENT, (RIGHT) THE COMPENSATING DIGITAL IMAGE THAT WAS CUT OUT, USING PHOTO-EDITING SOFTWARE, FROM A HIGH-RESOLUTION REFERENCE DIGITAL IMAGE OF THE MOCK-UP PAINTING BEFORE BEING DAMAGED.	176
FIGURE 96: (ABOVE) THE MOCK-UP PAINTING WITH DAMAGE PRESENT AT THE BOTTOM RIGHT CORNER, (BOTTOM) THE COMPENSATING IMAGE WAS PLACED DIGITALLY TO REPRESENT ITS APPEARANCE BY A PROJECTOR.....	177
FIGURE 97: A NUMBER OF PHOTO SHOTS OF THE PROJECTION OF THE COMPENSATING IMAGE PREPARED FOR THE VIRTUAL NON-INTERVENTIVE IMAGE REINTEGRATION PERFORMED FOR MOCK-UP PAINTING.....	178
FIGURE 98: A PIE CHART ILLUSTRATING RATIO PROPORTIONS OF RESPONDENTS ACCORDING TO GENDER	- 38 -
FIGURE 99: A PIE CHART ILLUSTRATING RATIO PROPORTIONS OF RESPONDENTS ACCORDING TO AGE GROUP....	- 39 -
FIGURE 100: A PIE CHART ILLUSTRATING RATIO PROPORTIONS OF RESPONDENTS ACCORDING TO GENDER	- 40 -
FIGURE 101: A BAR GRAPH ILLUSTRATING RATIO PROPORTIONS OF RESPONDENTS ACCORDING TO COUNTRY OF RESIDENCE.....	- 41 -

FIGURE 102: A BAR GRAPH ILLUSTRATING RATIO PROPORTIONS OF RESPONDENTS ACCORDING TO GENDER AND AGE GROUP - 42 -

FIGURE 103: A PIE CHART ILLUSTRATING RATIO PROPORTIONS OF RESPONDENTS ACCORDING TO THEIR YEARS OF EXPERIENCE..... - 43 -

FIGURE 104: A RANGE CHART ILLUSTRATING RATIO PROPORTIONS OF RESPONDENTS ACCORDING TO THEIR EXPERIENCE IN DIFFERENT PAINTING SUPPORTS - 43 -

FIGURE 105: A VERTICAL BAR GRAPH ILLUSTRATING RATIO PROPORTIONS OF RESPONDENTS ACCORDING TO THEIR DEGREE OF ACCEPTANCE OF THE AIRBRUSH AS A TOOL FOR FINE ART PAINTINGS - 44 -

FIGURE 106: A VERTICAL BAR GRAPH ILLUSTRATING RATIO PROPORTIONS OF RESPONDENTS ACCORDING TO THEIR OPINION ABOUT THE DEGREE OF ACCEPTANCE OF THE AIRBRUSH, IN FINE ART CIRCLES, AS A TOOL FOR FINE ART PAINTINGS - 44 -

FIGURE 107: A VERTICAL BAR GRAPH ILLUSTRATING RATIO PROPORTIONS OF RESPONDENTS ACCORDING TO THEIR OPINION ABOUT THE POSSIBILITY THAT PAINT APPLICATION TECHNIQUES AFFECT THE CONDITION OF PAINTINGS - 45 -

FIGURE 108: A VERTICAL BAR GRAPH ILLUSTRATING RATIO PROPORTIONS OF RESPONDENTS ACCORDING TO THEIR OPINION WHETHER ART CONSERVATORS ARE KNOWLEDGEABLE ABOUT PROBLEMS THAT MIGHT BE DIRECTLY RELATED TO PAINTINGS EXECUTED WITH AIRBRUSHING TECHNIQUES - 45 -

FIGURE 109: A VERTICAL BAR GRAPH ILLUSTRATING RATIO PROPORTIONS OF RESPONDENTS ACCORDING TO THEIR OPINION WHETHER ART CONSERVATORS ARE UNKNOWLEDGEABLE ABOUT PROBLEMS THAT MIGHT BE DIRECTLY RELATED TO PAINTINGS EXECUTED WITH AIRBRUSHING TECHNIQUES - 46 -

FIGURE 110: A VERTICAL BAR GRAPH ILLUSTRATING RATIO PROPORTIONS OF RESPONDENTS ACCORDING TO THEIR OPINION WHETHER THEY HAVE A CLEAR IDEA A CLEAR IDEA OF THE CONSERVATION TREATMENT THEY MAY SAFELY USE IN AIRBRUSH PAINTINGS THAT REQUIRE IMAGE REINTEGRATION - 46 -

FIGURE 111: A VERTICAL BAR GRAPH ILLUSTRATING RATIO PROPORTIONS OF RESPONDENTS ACCORDING TO THEIR DIRECT EXPERIENCE WITH AIRBRUSH PAINTINGS - 47 -

FIGURE 112: A VERTICAL BAR GRAPH ILLUSTRATING RATIO PROPORTIONS OF RESPONDENTS ACCORDING TO THEIR OPINION WHETHER CONSERVATION PROBLEMS IN AIRBRUSH PAINTINGS ARE DIFFERENT FROM THOSE IN PAINTINGS EXECUTED WITH OTHER PAINT APPLICATION TYPES. - 48 -

FIGURE 113: A VERTICAL BAR GRAPH ILLUSTRATING RATIO PROPORTIONS OF RESPONDENTS ACCORDING TO THEIR EXPERIENCE WITH THE CONSERVATION TREATMENTS AND PROCEDURES THAT AIRBRUSH PAINTINGS OFTEN REQUIRE - 49 -

FIGURE 114: A VERTICAL BAR GRAPH ILLUSTRATING RATIO PROPORTIONS OF RESPONDENTS ACCORDING TO THEIR EXPERIENCE WITH THE THICKNESS OF THE GROUND LAYER IN AIRBRUSH PAINTINGS COMPARING TO OTHER TYPES OF PAINTINGS - 50 -

FIGURE 115: A VERTICAL BAR GRAPH ILLUSTRATING RATIO PROPORTIONS OF RESPONDENTS ACCORDING TO THEIR EXPERIENCE WITH THE THICKNESS OF THE PAINT FILM IN AIRBRUSH PAINTINGS COMPARING TO OTHER TYPES OF PAINTINGS..... - 51 -

FIGURE 116: A VERTICAL BAR GRAPH ILLUSTRATING RATIO PROPORTIONS OF RESPONDENTS ACCORDING TO THEIR EXPERIENCE WITH THE DETERIORATION PROBLEMS THAT THEY MIGHT HAVE ENCOUNTERED IN THE PAINT FILM IN AIRBRUSH PAINTINGS - 52 -

FIGURE 117: A VERTICAL BAR GRAPH ILLUSTRATING RATIO PROPORTIONS OF RESPONDENTS ACCORDING TO WHICH OF THE PAINT MEDIUMS WAS DOMINANTLY EMPLOYED IN AIRBRUSH PAINTINGS THEY ENCOUNTERED- 53 -

FIGURE 118: A VERTICAL BAR GRAPH ILLUSTRATING RATIO PROPORTIONS OF RESPONDENTS ACCORDING TO HOW OFTEN THEY ENCOUNTERED AN EXISTENCE OF VARNISH LAYER IN AIRBRUSH PAINTINGS - 54 -

FIGURE 119: A PIE CHART ILLUSTRATING RATIO PROPORTIONS OF, IN RESPONDENTS’ OPINIONS, PROBLEMS FOUND SPECIFIC TO AIRBRUSH PAINTINGS ACCORDING TO NUMERICAL DATA EXTRACTED FROM VERBATIM RESPONSES..... - 54 -

FIGURE 120: A PIE CHART ILLUSTRATING RATIO PROPORTIONS OF, IN RESPONDENTS' OPINIONS, DETERIORATION TYPE(S) IN THE PAINT FILMS OF AIRBRUSH PAINTINGS THEY ENCOUNTERED ACCORDING TO NUMERICAL DATA EXTRACTED FROM VERBATIM RESPONSES. - 55 -

FIGURE 121: A VERTICAL BAR GRAPH ILLUSTRATING THE COUNT OF RESPONDENTS ACCORDING TO THEIR DIRECT EXPERIENCE IN THE CONSERVATION TREATMENT OF AIRBRUSH PAINTINGS COMPARED TO THEIR TOTAL LEVEL OF EXPERIENCE IN THE FIELD OF THE CONSERVATION OF FINE ART. NOTICEABLY, THE MAJORITY OF CONSERVATORS WHO PARTICIPATED IN THIS SURVEY AND INDICATED THAT THEY HAVE DIRECT EXPERIENCE IN THE CONSERVATION OF AIRBRUSH PAINTINGS HAVE 10 YEARS OR ABOVE OF EXPERIENCE IN THEIR FIELD.. - 55 -

FIGURE 122: A VERTICAL BAR GRAPH ILLUSTRATING THE COUNT OF RESPONDENTS ACCORDING TO THEIR DEGREE CONFIDENCE TO CARRY OUT IMAGE REINTEGRATION IN AIRBRUSH PAINTINGS, COMPARED TO THEIR ACTUAL EXPERIENCE WITH THE CONSERVATION TREATMENT OF AIRBRUSH PAINTINGS. INTERESTINGLY, SIX RESPONDENTS BELIEVE THEY HAVE A CLEAR IDEA OF THE CONSERVATION TREATMENT YOU MAY SAFELY USE IF THEY HAVE AN AIRBRUSH PAINTING THAT NEEDS IMAGE REINTEGRATION, DESPITE THEY STATED THAT THEY HAVE NEVER WORKED ON AIRBRUSH PAINTINGS. ON THE OTHER HAND, THERE ARE OTHER FIVE RESPONDENTS WHO INDICATED THAT THEY DO NOT HAVE A CLEAR IDEA OF SUCH A CONSERVATION TREATMENT, ALTHOUGH THEY STATED THAT THEY ACTUALLY WORKED ON AIRBRUSH PAINTINGS. - 56 -

FIGURE 123: LINEAR CHART REPRESENTS A TIMELINE OF CHANGES IN COLOUR VALUE (ΔE^*_{AB}) ACCORDING TO THE READINGS OF THE ACCELERATED LIGHT-AGEING CYCLES FOR THE AIRBRUSHED PRIMARY CYAN SAMPLE- 108 -

FIGURE 124: LINEAR CHART REPRESENTS A TIMELINE OF CHANGES IN COLOUR VALUE (ΔE^*_{AB}) ACCORDING TO THE READINGS OF THE ACCELERATED LIGHT-AGEING CYCLES FOR THE PAINT-BRUSHED PRIMARY CYAN SAMPLE..... - 108 -

FIGURE 125: A COMPARISON BETWEEN A SPECTROPHOTOMETRIC GRAPH OF AN ARTIFICIALLY AGED AIRBRUSHED PRIMARY CYAN SAMPLE (ABOVE) AND A SPECTROPHOTOMETRIC GRAPH OF AN ARTIFICIALLY AGED PAINT-BRUSHED PRIMARY CYAN SAMPLE (BELOW) - 109 -

FIGURE 126: LINEAR CHART REPRESENTS A TIMELINE OF CHANGES IN COLOUR VALUE (ΔE^*_{AB}) ACCORDING TO THE READINGS OF THE ACCELERATED LIGHT-AGEING CYCLES FOR THE AIRBRUSHED PRIMARY MAGENTA SAMPLE..... - 111 -

FIGURE 127: LINEAR CHART REPRESENTS A TIMELINE OF CHANGES IN COLOUR VALUE (ΔE^*_{AB}) ACCORDING TO THE READINGS OF THE ACCELERATED LIGHT-AGEING CYCLES FOR THE PAINT-BRUSHED PRIMARY MAGENTA SAMPLE..... - 111 -

FIGURE 128: A COMPARISON BETWEEN A SPECTROPHOTOMETRIC GRAPH OF AN ARTIFICIALLY AGED AIRBRUSHED PRIMARY MAGENTA SAMPLE (ABOVE) AND A SPECTROPHOTOMETRIC GRAPH OF AN ARTIFICIALLY AGED PAINT-BRUSHED PRIMARY MAGENTA SAMPLE (BELOW)..... - 112 -

FIGURE 129: LINEAR CHART REPRESENTS A TIMELINE OF CHANGES IN COLOUR VALUE (ΔE^*_{AB}) ACCORDING TO THE READINGS OF THE ACCELERATED LIGHT-AGEING CYCLES FOR THE AIRBRUSHED PRIMARY YELLOW SAMPLE..... - 114 -

FIGURE 130: LINEAR CHART REPRESENTS A TIMELINE OF CHANGES IN COLOUR VALUE (ΔE^*_{AB}) ACCORDING TO THE READINGS OF THE ACCELERATED LIGHT-AGEING CYCLES FOR THE PAINT-BRUSHED PRIMARY YELLOW SAMPLE..... - 114 -

FIGURE 131: A COMPARISON BETWEEN A SPECTROPHOTOMETRIC GRAPH OF AN ARTIFICIALLY AGED AIRBRUSHED PRIMARY YELLOW SAMPLE (ABOVE) AND A SPECTROPHOTOMETRIC GRAPH OF AN ARTIFICIALLY AGED PAINT-BRUSHED PRIMARY YELLOW SAMPLE (BELOW) - 115 -

FIGURE 132: LINEAR CHART REPRESENTS A TIMELINE OF CHANGES IN COLOUR VALUE (ΔE^*_{AB}) ACCORDING TO THE READINGS OF SECOND THE ACCELERATED LIGHT-AGEING CYCLES FOR THE AIRBRUSHED PRIMARY CYAN SAMPLE..... - 117 -

FIGURE 133: LINEAR CHART REPRESENTS A TIMELINE OF CHANGES IN COLOUR VALUE (ΔE^*_{AB}) ACCORDING TO THE READINGS OF SECOND THE ACCELERATED LIGHT-AGEING CYCLES FOR THE PAINT-BRUSHED PRIMARY CYAN SAMPLE - 117 -

FIGURE 134: COMPARISON BETWEEN A SPECTROPHOTOMETRIC GRAPH OF AN ARTIFICIALLY AGED AIRBRUSHED PRIMARY CYAN SAMPLE (ABOVE) AND A SPECTROPHOTOMETRIC GRAPH OF AN ARTIFICIALLY AGED PAINT-BRUSHED PRIMARY CYAN SAMPLE (BELOW) - (ACCELERATED AGEING TEST NO.2) - 118 -

FIGURE 135: LINEAR CHART REPRESENTS A TIMELINE OF CHANGES IN COLOUR VALUE (ΔE^*_{AB}) ACCORDING TO THE READINGS OF SECOND THE ACCELERATED LIGHT-AGEING CYCLES FOR THE AIRBRUSHED PRIMARY MAGENTA SAMPLE - 120 -

FIGURE 136: LINEAR CHART REPRESENTS A TIMELINE OF CHANGES IN COLOUR VALUE (ΔE^*_{AB}) ACCORDING TO THE READINGS OF SECOND THE ACCELERATED LIGHT-AGEING CYCLES FOR THE PAINT-BRUSHED PRIMARY MAGENTA SAMPLE - 120 -

FIGURE 137: COMPARISON BETWEEN A SPECTROPHOTOMETRIC GRAPH OF AN ARTIFICIALLY AGED AIRBRUSHED PRIMARY MAGENTA SAMPLE (ABOVE) AND A SPECTROPHOTOMETRIC GRAPH OF AN ARTIFICIALLY AGED PAINT-BRUSHED PRIMARY MAGENTA SAMPLE (BELOW) - (ACCELERATED AGEING TEST NO.2)..... - 121 -

FIGURE 138: LINEAR CHART REPRESENTS A TIMELINE OF CHANGES IN COLOUR VALUE (ΔE^*_{AB}) ACCORDING TO THE READINGS OF SECOND THE ACCELERATED LIGHT-AGEING CYCLES FOR THE AIRBRUSHED PRIMARY YELLOW SAMPLE - 123 -

FIGURE 139: LINEAR CHART REPRESENTS A TIMELINE OF CHANGES IN COLOUR VALUE (ΔE^*_{AB}) ACCORDING TO THE READINGS OF SECOND THE ACCELERATED LIGHT-AGEING CYCLES FOR THE PAINT-BRUSHED PRIMARY YELLOW SAMPLE - 123 -

FIGURE 140: COMPARISON BETWEEN A SPECTROPHOTOMETRIC GRAPH OF AN ARTIFICIALLY AGED AIRBRUSHED PRIMARY YELLOW SAMPLE (ABOVE) AND A SPECTROPHOTOMETRIC GRAPH OF AN ARTIFICIALLY AGED PAINT-BRUSHED PRIMARY YELLOW SAMPLE (BELOW) - (ACCELERATED AGEING TEST NO.2)..... - 124 -

Dedication

To my father, mother and sister,

To my wife and my two little ones,

For being the real treasure I have in my heart.

Acknowledgments

This thesis is the fruit of a long, and yet exciting learning journey into the specialism of the conservation of easel paintings and hosted by the renowned Northumbria University. I started the first part of this journey in September 2008 within the old walls of Burt Hall, where I learned the art conservation craftsmanship, and then achieved my first milestone in 2010 with a MA degree. The second part of the journey, the PhD research, started in January 2011, after which four years passed and filled up with various experiences which highly contributed to my learning.

This research would never have been conducted without the generous support that was kindly provided by a number of people.

First and foremost I would like to express my gratitude to my supervisors Miss. Jean Brown and Dr. Brian Singer for their guidance and support throughout this research project.

Special thanks go to the Cultural Affairs and Missions Sector of the Ministry of Higher Education and South Valley University (Egypt) and the Egyptian Cultural Centre & Education Bureau (London) for supporting and fully funding my scholarship.

I would also like to express my appreciation for the following people:

Dr. Angela Geary, my former supervisor for being supportive during the first steps of this research.

Dr. Andy Penaluna for lending me his unpublished thesis on the history of the airbrush.

Kayleigh Fuller for her kind and patient guidance and assistance on the use of the equipment needed for this research project, including the light ageing instrument, the spectrophotometer and the SEM.

Bob Best for providing guidance on using SEM.

Simon Walvin and Ken Thompson in Squires Workshop for their assistance on using equipment needed for the infill-prints.

The art conservation practitioners who participated in the survey.

The fine artists participated in the survey, in particular Don Eddy, Nathan Walsh, Simon Hennessey and Hubert de Lartigue.

My friends and colleagues Salem Abdel-Gader and Katerina Spyrou for all their encouragement and support.

Finally, I would never have been able to walk alone into this journey without the unconditional love, kindness and patience from my amazing wife, parents and sister.

Declaration

I declare that no portion of the work contained in this thesis has been submitted in support of an application for another degree or qualification of this or any other university or other institute of learning.

Name:

Mohamed Abdeldayem Ahmed Soltan

Signature:

A handwritten signature in black ink, appearing to read 'Mohamed Soltan', written in a cursive style.

Date:

14 April 2015

Introduction: Research aims and Contextualisation

Context of the research

The study of airbrush paintings should be considered in conservation research as they became accepted as fine art and entered collections that have to be cared for. So far, this body of artworks is overlooked in conservation literature. The airbrush has even been little discussed in the literature pertaining to the history of fine art. The early publications on the airbrush were aimed at illustrators, graphic artists and photographers interested in photography retouching rather than artists. To the best of the researcher knowledge, this study is the first attempt to investigate airbrush paintings in the context of the conservation of fine art. This study also explores the origins of the airbrush and helps understand the history of airbrushing in terms of fine art painting.

In the late 19th Century, a man called Frank L. Smith, a photo-retoucher from Wisconsin, said: “there is perhaps no tool, that has ever been invented for the help of the artist, that has received so much abuse as the Air Brush” (Penaluna, 2003, p. 292). The prominent American artist Man Ray (1890-1976) says: “When I began painting with the airbrush I had already been accused of debasing art by painting with a mechanical instrument” (Naumann, 2003, p.186). These vague notions mentioned by Man Ray: ‘debasing art’ with a ‘mechanical instrument’ was ostensibly shared by many fine artists since the airbrush was first marketed in the late 19th Century and through the early years of the 20th Century. Interestingly, the word ‘mechanical’ was used as an accusation against the airbrush, almost from the moment the airbrush was first introduced to the market. The historical development and acceptance of airbrush will be described in chapter one.

Curiously, given that several artists became more encouraged to use airbrush techniques since the emergence of Pop Art in the 1950s (Curtis & Hunt, 1980, p.21), there is no logically straightforward reason as to why such an omission has arisen (Martin, 1983, p.13). However, early opposition against the use of the airbrush in paintings was merely based on preconception by traditional artists. The airbrush remained neglected by the vast majority of fine artists well into the Twentieth Century. Garner (2008, p. 80) asserts: “from the turn of the [Twentieth] century through to the 1920s the Aerograph¹ [a later synonym to the airbrush] is drawn in profile like a piece of plumbing, isolated

¹ The Aerograph is a generic name to the airbrush, particularly known through the first half of the Twentieth Century in England and other parts of Europe after ‘Aerograph Company, Ltd.’, which was the second name of Charles Burdick’s company that he founded in London. More detail is provided in chapter 1.

from any context.” The airbrush remained primarily a tool for retouching photographs and making illustrations since it was first introduced to the market in the mid-1880s. However, in the first decades of the Twentieth Century, a number of avant-garde artists – such as Man Ray, Siqueiros and Kandinsky – experimented with airbrushing techniques. By the mid-Twentieth Century the airbrush was adopted in easel painting by many Western fine artists, such as Jules Olitski, James Rosenquist and Chuck Close.

For more than 70 years, airbrush paintings increased in number and they now became part of the collections in several galleries and museums in the USA and Europe. Therefore, there could be a need in the near future for proper conservation treatment for such collections. Research into the materials used in easel paintings in the field of conservation of easel paintings is long established. However, until relatively recently there was often more focus on paintings executed with traditional materials while nearly overlooking modern ones². Airbrush paintings are no exception. Curiously, there is no source so far known to have investigated the impact of airbrushing techniques upon the condition of paintings. The established conservation scientist Tom Learner (2007, pp. 3–4) makes this point clear as he argues: “artists throughout the Twentieth Century experimented with all means of applying the paint to the substrate, such as paint rollers, spray guns, splashing and pouring – and this is another factor that can significantly affect the characteristics of the final paint film and its subsequent reaction to ageing and treatment”. Interestingly airbrushing, being one of the existing methods of applying the paint to the substrate, “can significantly affect the characteristics of the final paint film and its subsequent reaction to ageing and treatment” according to Learner’s remark. Accordingly, this study investigates possible differences in conservation issues between airbrush paintings and traditional paintings, and assesses current awareness of this subject by practitioners.

Research Aims and Objectives

An introductory inquiry for this study is raised. The inquiry is about the status quo of airbrush paintings in the context of the history of fine art. In order to tackle such an investigation, it is essential to trace back the origins and early history of the airbrush. It is important to know how it was developed, when and where it was first manufactured. It is also important to obtain facts on how the

² It was in 1980 when an early major attempt to collaboratively investigate modern art has been made via the *International Symposium on the Conservation of Contemporary Art* (the National Gallery of Canada, July 1980). That was followed by a number of important symposia such as *Conservation and Contemporary Art* (Institute for the Conservation of Cultural Material, Sydney, 1985) and *Modern Art: Who Cares?* (The Foundation for the Conservation of Modern Art and the Netherlands Institute for Cultural Heritage, 1997) after which was the formation of the International Network for the Conservation of Contemporary Art (INCCA) in 1999.

airbrush was perceived from its outset. Subsequently, it is important to understand the role of the technique of airbrushing in fine art by exploring its early adoption in painting by fine artists. Answers to this preliminary investigation help determine the point when airbrush paintings became recognized among important art collections and thus considered for conservation research. This leads to the main proposed hypothesis with regard to airbrush easel paintings. The hypothesis is that such paintings could pose conservation problems that are different, in any degree, than those posed by paintings executed using traditional techniques of paint application. Such conservation problems might not be necessarily manageable by conventional conservation treatments. Accordingly, this research has three main aims that can be summarised in the following points:

- To establish an understanding of the status quo of airbrush paintings.
- To identify unique conservation problems directly related to the technique of airbrushing.
- To determine the practicability of known conservation treatments based on the identification of the conservation problems related to airbrush paintings.

To achieve the aims of this research, objectives can be summarised in the following points:

- To explore the origins and early development of the airbrush.
- To explore how the airbrush was perceived from the outset of its commercial availability in the 1880s in the USA.
- To establish a better understanding of the circumstances surrounding the gradual acceptance of the airbrush as a tool for fine art painting. This includes tracing back its gradual transition from being an exclusively commercial art device to become a fine art tool.
- To keep track back of the first prominent fine artists who effectively used the airbrush and experimented with spray painting in their artworks.
- To explore current knowledge among art conservators about conservation problems relevant to airbrush paintings, and determine their main concerns accordingly.
- To empirically explore practicality of current conservation treatments according to the conservation problems identified through research.
- To determine and suggest effective, feasible and reversible conservation treatment based on the findings achieved.

Methodology

This research is based upon an interdisciplinary methodology that combines literature review, documentary analysis, questionnaires, empirical study and technical analysis. Research methods used are further demonstrated in the following points:

Literature review and documentary analysis:

In order to obtain facts about the early history of the airbrush it was necessary to gather information from reliable sources. One important source is a previous research conducted by Professor Andrew Penaluna who is currently the research director of the centre for creative entrepreneurship in the University of Wales. His research has been summed up in a PhD thesis entitled: “A Critical Investigation into the Origins and Development of the Airbrush - 1878-1906” (2003). The thesis is unpublished and it was difficult to obtain a copy. Professor Penaluna was kind enough to meet the researcher in person in 2011 for a discussion about his research and to lend him a copy of his thesis. Penaluna’s research is the most extensive investigation into the history of the airbrush. It is particularly important because it corrected common misconception about the original date of the first manufactured airbrush. For example, almost all work, published in the Twentieth Century on the airbrush and airbrushing techniques, unanimously claimed that the airbrush was first manufactured in 1893 by Charles L. Burdick, although it was originally manufactured in 1883 by Liberty Walkup.

Another important source of information was historical newspapers, patents, catalogues and other periodicals. These sources provided wealth of information on the early history of the airbrush and its development. More importantly, they provided insight to many aspects pertaining to how different interested parties contemporary to the early airbrush reacted to it. Interesting historical opinions, news and even advertisements related to the airbrush were gathered from these sources and helped realise various details and facts. Most of these sources were obtained from reliable online databases, including but not limited to, the British Library (British Newspaper Archive), Library of Congress (Chronicling America) and the National Library of Australia (Trove). The researcher also depended on other sources, including written works and documented video and audio recordings, to explore other information relevant to all the aspects and steps of this study.

Questionnaires

This method was used in order to obtain information about airbrush paintings in the current practice of art conservation by directly exploring the opinions and conceptions among art conservation practitioners. Questionnaires provided a valuable standardised research instrument to gather

quantitative and qualitative information needed for this research from as many experts as possible. Demarcation of target population was based upon the research context and aims. Accordingly, only art conservators with expertise in the conservation of easel paintings were selected. Questionnaires were built online distributed to them electronically via unique links. Each link was assigned only to each prospective respondent to prevent potential responses by irrelevant individuals. Quantitative and qualitative results were obtained from descriptive and normative responses to questions with fixed-choice answers. Qualitative results were also obtained from verbatim responses to open-ended questions. Further details on the objectives, strategy and design of the questionnaires are demonstrated in chapter 5.

Technical analysis and examination

Since the main purpose of this study is to look into the effect of the technique on airbrush paintings, it was essential to isolate other factors, such as the effect of the material. Therefore, this research focuses on the sprayed paint film, and only from the perspective of the paint application. It was also important to identify possible differences in conservation issues between airbrushed paints and traditionally applied paints of the same type on the same material. Accordingly, accelerated light ageing testing was chosen as a method to assess the potential durability of the airbrushed paint film compared to that applied with a paint brush.

Commercially available artist acrylic paints were used to prepare mock-up samples. Those paints initially underwent chemical analysis to identify the paints media and to scientifically confirm their nature. Analytical methods used for this purpose were Fourier transform infrared spectroscopy (FTIR) and pyrolysis gas chromatography mass spectrometry (Py-GC-MS).

Following accelerated light ageing testing, the mock-up samples were visually examined under a scanning electron microscope (SEM) along with reference corresponding samples that did not undergo ageing.

Empirical study

As the aforementioned methods revealed that image reintegration of airbrush paintings is a major concern, it was important to experiment with various conventional and non-conventional image reintegration treatments using a mock-up painting. Full account on this study is demonstrated in chapter 7.

Significance of the research

This study focuses on the airbrush from a new perspective with regard to its role in the modern history of fine art and the consequences of its use, in terms of both techniques and materials on the stability or deterioration of the paint film and potential conservation treatment. This study aims to fill a gap in the current literature in the field of conservation of fine art by addressing airbrush paintings which constitute an important part of art collections that could be susceptible to conservation issues that have not been studied before in more depth. Furthermore, this study also provides a suitable image reintegration treatment for airbrush paintings that is feasible and non-interventive in nature, using DLP LED Pico projectors. More details on the latter subject are fully demonstrated and discussed in chapter 7.

Overview of the contents

The thesis is divided into eight chapters. The first three chapters discuss the origins of the airbrush, its role in the field of fine art and the significance of modern paints which facilitated effective use of the airbrush in fine art paintings. The fourth chapter provides an overview of image reintegration treatments to introduce to the main research question with regard to tackling damaged paint surfaces of airbrush paintings. Chapters 5, 6 and 8 attempt to deal with the research aims via different approaches with the conclusion presented in chapter 8.

Chapter 1. The Airbrush: a History – explores the origins of the airbrush and the first airbrush device ever introduced in the market. Terminology is discussed and defined. The crucial role played by the introduction of compressed air equipment is described. It describes the popularity of the first generation of the airbrushes that was quickly superseded by the introduction of the much improved second generation. Chapter 1 also demonstrates the early recognition, and refusal, of the airbrush. It discusses how it was perceived by those who opposed it and how that opposition was debated.

Chapter 2. The Role of the Airbrush in the Field of Fine Art – explores the history of the earliest airbrush art school founded by the first manufacturer of the airbrush. It tracks the gradual recognition of the airbrush by fine artists in the 20th Century until becoming an essential tool to several artists by the 1960s, such as Chuck Close and Don Eddy.

Chapter 3. An Overview of Modern Paints and its Impact on the Use of the Airbrush in Fine Art Painting – explores commonly available types of synthetic paint media that became available in the market in the 20th Century. Furthermore, chapter 3 discusses the importance of the introduction of modern paints, chiefly acrylic paints, for the airbrush to become effectively used by fine artists.

- Chapter 4. An Overview of Image Reintegration Treatments for Paintings Conservation** – explores the history and discusses the terminology used as well as the range of approaches that can be taken to the image reintegration of a painting followed by a discussion of the ethics and aesthetic Involved in the various approaches.
- Chapter 5. Survey** – describes the two surveys that were developed in order to identify the issues that both artists and conservators might have experienced with the creation and conservation of air brush paintings respectively. Results, obtained from the questionnaires, are presented and discussed.
- Chapter 6. Chemical Analysis and Accelerated Light Ageing Test of Paint Samples: Experimental and Results** – Light ageing was used to help predict future changes in samples of spray paint. Instrumental analysis was used to investigate the physical and chemical characteristics of the spray paint before and after light ageing. It presents and discusses results and draws comparison of airbrushed and paint-brushed samples that were artificially light-aged.
- Chapter 7. Suggestions for Possible Treatments to Image-Reintegrate Airbrush Paintings** – a range of none traditional image re-integration techniques were investigated and practical research conducted to determine their viability. The processes and their appropriateness is discussed.
- Chapter 8. Discussion, Conclusions and Recommendations** – sums up findings and draws conclusions and recommendations for extended areas to the subject of this study.

Three appendices are included in the thesis. The first appendix (A.1) contains the full two questionnaires aimed at art conservators and fine artists. The second appendix (A.2) contains tables, charts and spectrophotometric graphs of artificially light aged airbrushed and brushed samples discussed in chapter 6. The third appendix (A.3) contains images of the different the aged and non-aged samples examined via scanning electron microscope (SEM) discussed in chapter 6.

Chapter 1 – The Airbrush: Technical History

1.1 Introduction

Since the focus of the research is on the method of application of the airbrush, it is important to look at the equipment itself; how it was developed, how it worked and was used. Accordingly, this chapter demonstrates the origins of the airbrush which goes back to the 1870s. It follows the early developments that eventually led towards the earliest mass production of the device in the 1880s. The introduction of the airbrush was a success, albeit rather initially used for commercial purposes such as retouching photographs rather than for fine art where it was reportedly met by scepticism and criticism by many artists.

1.2 Airbrush: definition of a term

A range of definitions and descriptions are found in the literature with regard to the airbrush. An example is a definition introduced in *Cassell's Cyclopaedia of Photograph*³ (Jones, 1911, p. 12): “A mechanical sprayer working by means of compressed air, and used for finishing and working up both prints and negatives.” Tobias (2012, p. 1) defines the airbrush as “an instrument designed to convey paint or color from the supply reservoir to the work, in a very finely-divided spray, by means of air pressure.”

Penaluna (2003, p. 18), seeking a definition for the word ‘airbrush’, he points out that “the defining factor [of the airbrush] was declared to be the requirement of compressed air with which it is driven.” Thus he refers to “discussions with the European, Canadian and American Airbrush Associations.” The discussions came to the following definition which has been agreed by the presidents⁴ of those associations: “a small hand-held spraying device that is powered by compressed air and used for artistic purposes.” This definition is more descriptive and accurate when compared to those of Jones and Tobias.

Interestingly, the word “airbrush” is not restricted to describing the device; other meanings can also be derived from it when it is used as a verb. In the Merriam Webster dictionary (‘Definition of Airbrush’, 2011) the verb “airbrush” means: “to paint, treat, or alter (as to conceal imperfections) with

³ In *Cassell's Cyclopaedia of Photograph* the term “aerograph” is preferred over “air-brush”. This is most likely because the instrument was first marketed by Charles Burdick in England in the late 19th century under the name “aerograph”. Further on this subject is discussed later in this chapter.

⁴ Penaluna mentions those presidents by name: “Mike Ettiene of Dortmund, Germany, Dawn Copland of Windsor, Ontario and Micky Harris of Tennessee were the respective association Presidents when these discussions took place.”

or as if with an airbrush”. There is also an idiom derived for the word “airbrush”; “*airbrush out*” often used to indicate the act of the suppression or concealment of certain details in images or information. The Merriam Webster dictionary claims that the first known use of “airbrush” as a verb was around 1938.

1.3 Compressed air: the power for the airbrush

The development of the airbrush as we know it today was almost entirely dependent upon the introduction of air compressors. It is commonly claimed that Otto Van Guericke, a German scientist, devised the earliest mechanical air pump in 1654. The Anglo-Irish Chemist Robert Boyle was soon inspired by the work of Guericke. Boyle finished an improved version of Guericke’s air pump that he called ‘Pneumatical Engine’ in 1659 (Wilson, 1849, p. 12). Further improvements were soon attempted, and in 1799 the English mechanical engineer George Medhurst reportedly designed the first motorised air compressor by means of a windmill (Drinker, 1883, p. 136). McShane believes that “from that time on compressed air began to be recognised as a simple and valuable power, and it grew constantly in popularity.” (1899, p. 583)

By the end of the nineteenth century, Rand (1894) published an interesting little book in which he included a wide variety of the inventions and applications which depended on compressed air. He talked about applications like drilling, pumping, weaponry and manufacturing purposes. He included a summary and an illustration for each application he presented. This book shows that, relatively early after its development, compressed air had been utilised in a wide range of applications. Two pages in the book were assigned to talk about the airbrush as one of the inventions based on compressed air and its applications in both industrial and artistic fields. The Following quotation clearly identifies the main characteristics that the airbrush offered, an even tonal gradation and the ability to cover large areas quickly, which were difficult to achieve with a brush:

Repeated experiments in atomizing paint by compressed air, have resulted in successfully applying pigments to great surfaces; as well as perfecting the air brush, by which a marvellously delicate application of color to portraits and pictures, can be secured. These are the extremes of practically the same idea. (Rand, 1894, p. 114)

By the early 1900s there were three types of air compressors used for airbrushing; manually-operated pumps, liquid carbonic gas cylinders and electrical air compressors (Figure 1, Figure 2, Figure 3). The introduction of electrical air compressors made the electrical airbrush more practical than the other types, and its use was praised by writers at that time (Stine, 1920, p. 20).

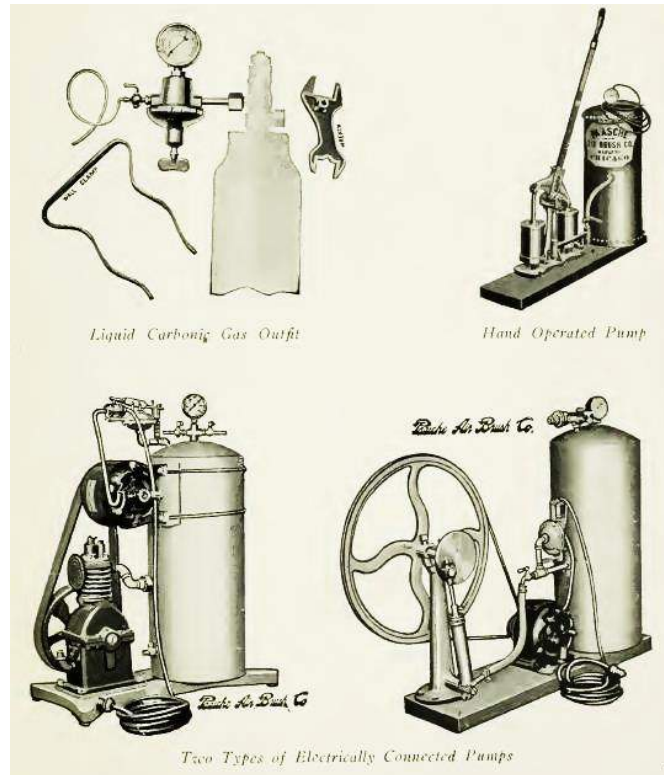

Figure 1: types of air compressors from the early 20th Century. Top left: 'liquid carbonic gas outfit', top right: 'hand operated pump', bottom: 'two types of electrically connected pumps' (Stine, 1920, p. 21)

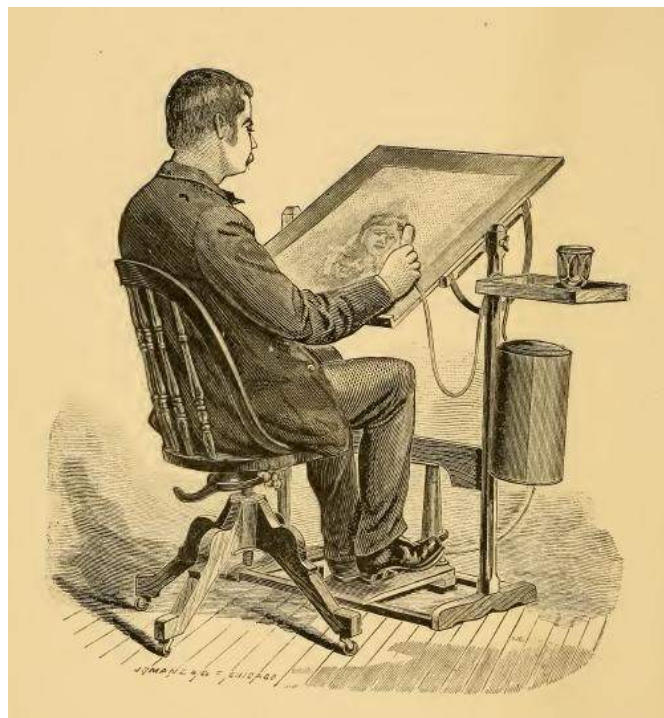

Figure 2: a drawing from the late 19th Century of a man working with an airbrush powered by a manual air pump with a foot pedal (Air Brush Manufacturing Company Rockford, 1887, p. 8)



Figure 3: a photograph from the early 20th Century of an illustrator while using an airbrush powered by an early type of electrical air compressor (Stine, 1920, p. 148)

1.4 A History of the Airbrush

The earliest airbrush patent known, which was basically intended for retouching and colouring photographs, was dated 19 September 1876 and was introduced by Frank E. Stanley as “an improvement in atomizers”. Stanley states that his invention relates to “such improvements in atomizers that they may be employed for finishing photographs in water colors, india-ink or crayon and also for all kinds of shading in which color can be used in a liquid state” (Stanley, 1876). Despite the existence of earlier forms of ‘atomisers’ improved by others – like Shurtleff (1866), (1869), (1871)⁵, Lockwood (1872)⁶, Gerard (1873)⁷, Spencer (1875)⁸, Wallace (1876)⁹ and Holmes (1876)¹⁰ –

⁵ In his 1866 patent, Shurtleff states that his invention “relates to the construction of the instrument... used more particularly for producing local anaesthesia, and known as atomizing or nebulizing tubes and as spray producer.” Shurtleff later patented further improvements in his invention. In his patent of 1871, he states that he added a “flexible elastic bulb” operated by hand, in order to supply “the current of air... to the air tube of the atomizer.”

⁶ Lockwood’s improvement in atomizers alters the position, size and shape of the air and liquid tubes to achieve, as he claims, finer jets of liquid sprayed. His device was also hand-operated with an “elastic air-bulb that alternately receives the air and supplies the atomizer air-tube.” Later patents of later improvements in atomizers by Lockwood also exist.

Stanley was the first to make clear that the purpose of his invention is to apply sprayed paint to 'retouch' photographs.

Stanley's atomiser (Figure 4) was intended to spray paint as uniformly as possible (Stanley, 1876) as was made clear in the patent. This design incorporated new features for the purpose of controllability. The most important of these being a needle or a "wire" inserted into a "liquid tube" to control the amount of spray. The needle was adjustable with a set-screw. This early example of an airbrush has never become commercially available.

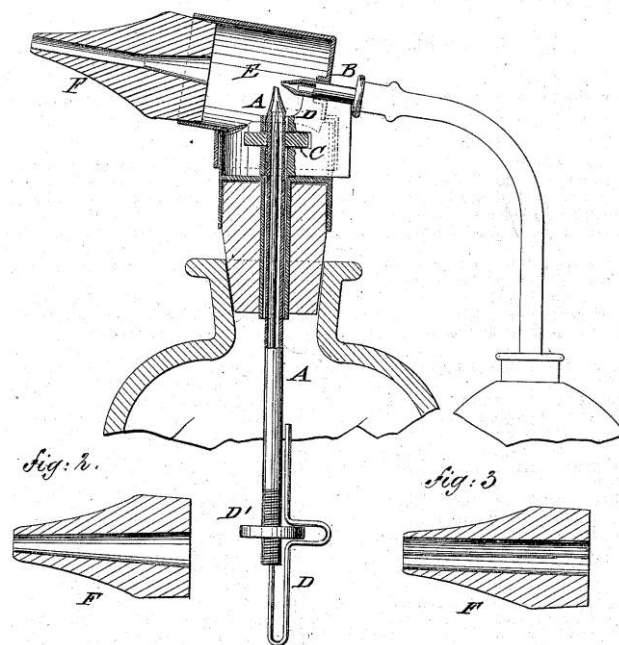

Figure 4: Illustration of Stanley's model of an 'atomizer'. This is considered as the first type of the airbrush

Stanley's original patent, was followed by further improvements by later innovators. A series of related patents were later issued. In 25 October 1881 Leslie L. Curtis patented his "Atomizer for

⁷ Gerrard's idea was to let a jet of liquid comes out first from the nozzle of his vaporising device and then broke up to finer droplets by an air jet.

⁸ Spencer claims that his improvement in atomisers is designed "not only for diffusing perfumes or disinfectants, but also as a douche for various organs in the body." This device was also hand-operated by means of an air bulb.

⁹ Wallace's patent was on an improvement in atomisers. He says that the object of his invention was "to improve the manner of sustaining the air-chamber connected with an atomizer."

¹⁰ Holmes made further enhancement on the contemporary atomisers, the most notable is adding a valve to his device in order to add more control over the air current needed to "vaporise" the liquid.

Coloring Pictures” which was – as claimed by Curtis – a "device for easy, accurate, and rapid distribution of coloring and shading upon drawings and paintings". (Curtis, 1881) Curtis’s atomizer was a further improvement to Stanley’s model.

Two years earlier, in 1879, Abner Peeler¹¹ has already had his unique concept of an airbrushing instrument implemented (*Fort Dodge Chronicle*, 1893)¹². He has also given his invention a unique name; “Paint Distributer”. A month later, Peeler put his invention to test by executing a spray painting of a self-portrait copied from a photograph (Figure 5). Although Peeler was not granted a patent before 1882, he was able to make some profit from his device. Peeler (*Fort Dodge Chronicle*, 1893) asserts that he sold the first prototype for ten US dollars. He then sold his patent rights to Liberty Walkup in 1881 for seven hundred dollars. On 25 April 1882 Peeler’s Paint Distributer was officially patented. The names of the brothers Liberty and Charles Walkup were present as the assignees (owners) of the patent (Peeler, 1882).

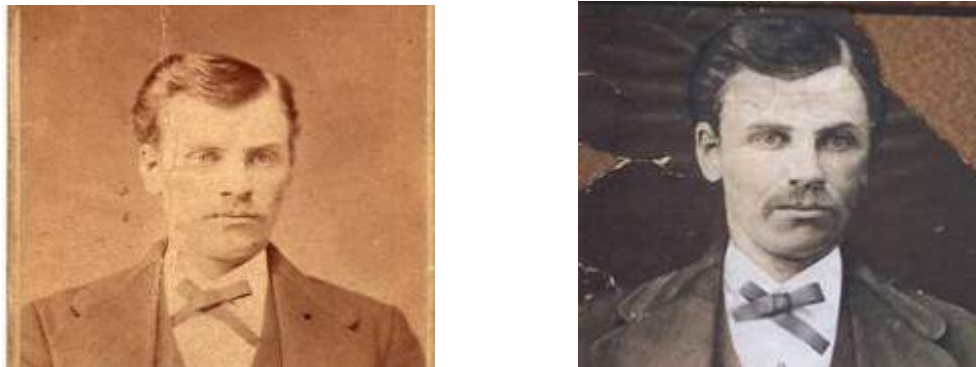

Figure 5: (Left) A photograph of Abner Peeler. (Right) Self-portrait copied by Peeler from his own photograph. The spray-painting was executed fully with Peeler’s Paint Distributer only a month after its invention (Peeler, 1882).

Few further refinements to the original Peeler model have been patented by Liberty Walkup. The latter was granted three patents for modifications done to the device, but the name “Paint Distributer” continued to be used. The first patent was issued on 18 September 1883 (Walkup, 1883) , the second on 6 May 1884 (Walkup, 1884) and the third on 13 January 1885 (Walkup, 1885). Liberty Walkup’s

¹¹ Peeler is known to have been an active inventor who has done various inventions, some of them are considered highly innovative at the time. Penaluna (2003, p. 51) states: “Peeler is acknowledged to have made a great number of inventions. These ranged from a Sewing Machine Shuttle to an instrument combining a Violin with an Accordion, and from a design of Roller Skate to, a giant three-wheeled Velocipede. He is best known however, albeit primarily in the State of Iowa only, as the inventor of the first typewriter.”

¹² Peeler himself mentions these details in a letter he sent as a reply to Mrs. Heppler who asked him for information about his inventions. Mrs. Heppler had then read his letter before “The World’s Fair Club” which it had been later published in the *Fort Dodge Chronicle* in 1893.

aim was to improve his device in order to make it a “more efficient machine of its class in a more convenient and practical form” (Walkup, 1884).

These successive modifications (Figure 6) were intended to create a more convenient and effective device that would appeal to a wider, broader market. Several visible parts in Peeler’s original model, such as the ‘wind-wheel’, were placed inside the body of the device in the final version in order to make it more compact and portable (Figure 7). In addition, the equipment was modified so that it could be operated with just one hand rather than the two hands required in the original. The most important addition was the ‘double-action’ function. That allowed the flow of air and paint to be controlled with just one trigger. The trigger could be depressed to let the air flow which could then be adjusted, to create various widths of paint on a substrate, by pulling the trigger back.

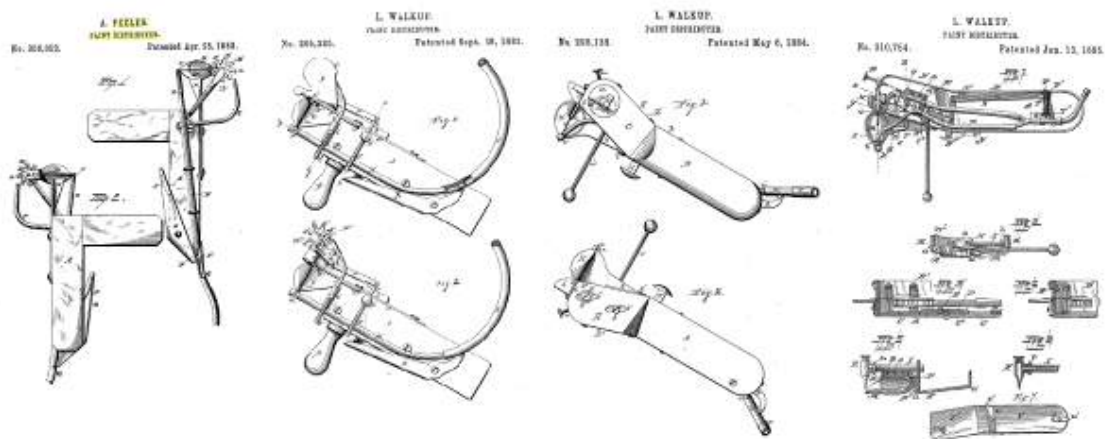

Figure 6: Peeler/Walkup Paint-Distributer patents. From left to right; Peeler’s original model (1882), Walkup’s initial improvements (1883), Walkup’s further improvements (1884), Walkup’s final version to be ready for the market. The final versions of the device were improved to become more portable. The portability was not only about the size of the airbrush, but more importantly controlling it by one hand through one trigger. (1885)

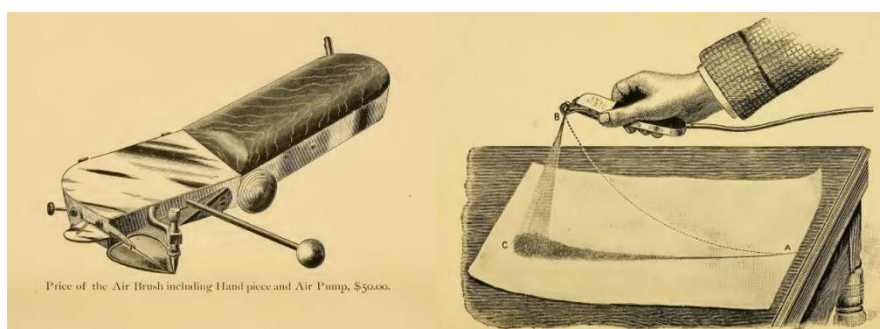

Figure 7: one of the earliest prototypes of the airbrush (left) and a drawing showing how to hold and control the device (right), as advertised in a company’s booklet (Air Brush Manufacturing Company (Rockford, 1887, pp. 10, 28). Despite its principle is the same as that of later airbrush prototypes made by other companies, the design is completely different from the airbrush as we know it today.

It was quite clear from the marketing materials that Walkup had been modifying his device in order that it appeals to artists. In none of the three patents does he mention that the device might be of use in the field of photography. Instead, he maintains that his “air-brush” is designed to be employed “in the art of painting in producing likenesses of nature or art” (Walkup, 1883) , “in the art of painting, but more especially in the fine arts” (Walkup, 1884) and to “produce portrait, landscape, &c” (Walkup, 1885). Despite these statements, the ‘paint distributor’ did not really catch on with artists and remained predominantly a tool utilised by photographers and illustrators. The development of artistic interest in the air brush will be discussed more fully in chapter two.

The Air Brush MFG. Co.: the First Manufacturers

The Walkups were keen to get their new device onto the market as quickly as possible and started production and marketing well in advance of the first modified patent being issued by the US Patent Office on 18 September 1883. As soon as that patent was filed on 6 December 1882 the Walkups launched their product to the market. The early success of the device was such that in April 1883 the brothers were able to found their own company (Browne, 1891, p. 49) which was initially called “The Rockford Manufacturing Co.” and was presided over by Liberty Walkup and it was located at North Main Street in Rockford Illinois. The capital of the company was fifty thousand US dollars collected as common stock shares (Merlin, 2011), which was the equivalent of nearly half a million dollars in 2015 and indicates the magnitude of their success and the popularity of the device.

In September 1883, the editorial *The Philadelphia Photographer* described a demonstration of the device by a representative of the Rockford Manufacturing Co. The presentation took place in an exhibition attached to the fourth annual convention held by the Photographers’ Association of America in Milwaukee on 4th August 1883. The editor describes the newly marketed airbrush as “one of the most attractive novelties of the Milwaukee exhibition” (Wilson, 1883). He also asserts that, within two or three months, the manufacturer [i.e. Rockford Manufacturing Co.] would be able to “handle this business” – the airbrush – “with activity and intelligence”. Finally, the editor promises his readers to bring any further information about that new product as soon as it is available.

As the business grew the brothers decided to change the name of the company in order to appeal to a wider market. The brothers felt that by renaming the device an ‘air brush’ it would have greater appeal, especially amongst those artists who were reluctant to be parted from their more traditional brushes. At the same time they renamed the company “the Air Brush MFG. Co.” abbreviated from the full name: “the Air Brush Manufacturing Company” (Penaluna, 2001). This change had been applied on 6th October 1883, just 6 months after the creation of the company. One month later, the November issue of *The Philadelphia Photographer* displays an advertisement for the Air Brush MFG. Co. The

advertisement shows a man sitting at an easel equipped with an air pump operated by a treadle while using an airbrush to paint with just one hand (Figure 8). Very attractive slogans have been claimed: “The Greatest Invention, pertaining to Art, of the Nineteenth Century”, “A New Principle in Color Distribution” and that “Artists can Get Effects Never before Attained”(The Philadelphia Photographer, 1883).



Figure 8: The first advertisement published by The Air Brush Manufacturing Company in *The Philadelphia Photographer* newsletter in November 1883 shows the ease with which paint can be applied using just one hand (The Philadelphia Photographer, 1883).

1.5 Recognition of the new instrument

The Air Brush Company apparently made every effort possible to publicise itself in the market. It can be seen that the company had launched a determined advertising campaign using different types of the media available at that time. Almost continuously, a series of advertisements can be traced, for example, in *The Philadelphia Photographer* since November 1883. The Air Brush Company also published flyers and pamphlets to make an extended description of the product available to prospective customers. Apart from advertisements, some early articles have also been published to

discuss the innovative product. In January 1884 the editor of *The Philadelphia Photographer* Edward Wilson writes again about the airbrush to briefly describe its principle. Wilson, who also was a professional photographer, has had “no doubt” that the airbrush “will be the most helpful adjunct” to the field of photography – which he describes as the “wonderfully growing art” (Wilson, 1884a). In October 1884 The New York Times also mentioned the Air Brush as one of the ‘novelties’ exhibited at the Great Fair held by the American Institute in New York in the same year (*Attractions of the Great Fair*, New York Times, 1884, p. 7).

The Air Brush Company gave much attention to its own publications pertaining to its product as an essential part of its marketing campaign. The first pamphlet, which contained a description and price list, was believed to be issued by the company between December 1883 and January 1884 (Wilson, 1884a). The second print of this pamphlet, issued in 1884, claims that their airbrush gained “immediate success [more] than any other invention” marketed at that time (*Description and Price of the Air Brush*, 1884, p. 3). It also claims that there were very few purchasers, only “one in every sixty four”, who were dissatisfied with the product “during the first year of sales”. Positive testimonials were also included in the pamphlet to show that the customers were pleased with the airbrush. As stated in the price list included in the pamphlet, the price of the airbrush complete with the air pump was \$50¹³ with an optional easel at \$5. A few years later, in 1892, reduced prices were announced for the airbrush to be at \$40 and various optional accessories and spare parts were also added (Figure 9).

¹³ Equivalent to around \$1400 as of the year 2014 according to CPI (the Consumer Price Index) calculation provided by Federal Reserve Bank of Minneapolis (minneapolisfed.org).

PRICE LIST	
OF THE	
Air Brush Manufacturing Co.,	
ROCKFORD, - ILLINOIS.	
L. WALKUP, President,	
L. B. GREGORY, Vice-President,	
W. W. BENNETT, Secretary and Treasurer.	
Air Brush (Plain).....	\$40.00
Air Brush (Jeweled).....	45.00
Basel.....	5.00
Wheel.....	1.00
Wheel balanced on shaft.....	1.25
Upper wheel bearings (left hand screw) 25 cents each. One at end of walk- ing bar shaft is duplicate.	.10
Lower wheel bearing.....	.25
Thumb piece to air valve.....	.25
Needles, per dozen.....	.10
Walking bar shaft.....	.50
Spoons, each.....	1.00
Left hand spoons.....	.25
Wheel shaft.....	.10
Screws not wheel bearings.....	1.25
Downward blast point and tube com- plete.....	1.00
Blast point only.....	.25
Blast to feed wheel.....	.35
Walking bar.....	.10
Needle guide.....	.25
Screw drivers, each.....	.15
Tweezers, each.....	.25
Carriage key.....	.05
Plunger caps for pumps, each.....	.25
Rubber Tubes for inside of brush, per dozen.....	.15
Needle set screw.....	.08
Tubing from pump to can, per foot.....	.07
From can to hand piece, per foot.....	2.00
Main or K valve complete.....	5.00
Carriage for brush complete.....	10.00
Carriage for brush complete, jeweled.....	5.00
Pump complete.....	.25
Lamp black, per pan.....	.25

Figure 9: Price list of products, accessories and spare parts marketed by the Air Brush MFG. Co. and published in *The Air Brush Journal* (Bennett, 1892)

In 1891 the Air Brush Company published its own magazine called *The Air Brush Journal*. An expressive slogan headed every issue: “He Who Saves Time Strengthens Life” (Bennett, 1892), as an indication to the manufacturer’s claim that the airbrush “saves an unnecessary expenditure of time” of an artist (*Description and Price of the Air Brush*, 1884). The editor of that magazine was Will Bennett Jr. who also was the assistant secretary of Walkup’s company, and whose father, W. W. Bennett, was the secretary and treasurer (Browne, 1891, p. 49).

In addition, other marketing strategies were implemented by Walkup’s company. For instance, the airbrush was offered to customers for a free trial of a month and a discount was also offered to those who decided within ten days to keep it (Bennett, 1892, p. 3). Free one year subscription to *The Air Brush Journal* was offered to those who were able to send a list of their artist friends to the editor. Free repair work was offered to those who have had broken airbrushes (Convention Pointers, Wilson, 1888a, p. 411). The company also published a directory which included established airbrush artists of the time. That directory was to provide a “medium of communication” between such artists and their prospective employers whose demand has “far exceeded the supply of artists of whom the company knew” (A Commendable Enterprize, Wilson, 1887a, p. 32).

Furthermore, the Air Brush Company announced in May 1887 prizes to be awarded at the Eighth Annual Convention of the Photographers’ Association of America, later held in Chicago in August of the same year. Two prizes were offered; one for “the best portrait in black and white” and the other

for “the best water color portrait”, and both had to be finished “exclusively with the Air Brush” (The World’s Photography Focussed, Wilson, 1887b, p. 277). That step was successful, not only that it improved the company’s sales, but also it developed more awareness of the advantages of airbrushing in art. In 1886, a year earlier, Wilson (1886, p. 159) writes that the airbrush was not yet “fully appreciated among photographers”. In October 1887, only two months after the airbrush competition at Chicago’s Convention, he maintains that the airbrush sales were “made largely to photographers”. Moreover, he adds that the airbrush also became largely employed in other fields, such as photo-enlarging and lithography. This success probably led Wilson (1886, p. 608) to enthusiastically expect in the same editorial that, in time, the airbrush will be recognised by the “artistic world”.

This expectation seems to have begun to be true very early. In July 1888, the Ninth Annual Convention of the Photographers’ Association of America was held at Minneapolis. In August of the same year *The Philadelphia Photographer* pithily announced the two winners of the Air Brush Co. awards who have done good retouching for their photographic prints using airbrush. Afterwards there was a more lengthy statement about a “fine display of Air-Brush work” which “unfortunately, much of it being free hand, could not compete for the prizes, which were for print work solely”. The magazine thus suggested offering prizes “for free-hand work as well as print” (Proceedings of the Photographers’ Association of America, Wilson, 1888b, p. 467).

As early as 1886 the airbrush received a very important recognition from the Franklin Institute, from which the Air Brush Manufacturing Company was awarded the Elliot Cresson Medal, the highest award that the Institute would grant at that time. The following text is the entire report and announcement of the award published in the *Journal of Franklin Institute* upon the examination of the Air Brush by committee members (Franklin Institute, 1887, pp. 157–159):

[No. 1358.]

Hall of the Franklin Institute,
Philadelphia, August 30, 1886.

The Sub-Committee of the Committee on Science and the Arts, constituted by the Franklin Institute of the State of Pennsylvania, to whom was referred for examination the

AIR-BRUSH

of the Air-Brush Manufacturing Company of Rockford, Ill., respectfully

Report: That after an examination of the instrument and its uses, they regard it as deserving of the warmest commendation. The application of the principle of the air-brush to a tool for distributing liquid pigments on to paper or other surfaces in the production of pictures, is a great novelty in the arts, and as important in its economy of time as it is novel. In the hands of an accomplished draughtsman, it is an acquisition of rare value.

Of course, this instrument cannot make up for any deficiency of artistic skill in the operator, for, as much proficiency in drawing practice is necessary with this as with any other of the pencils or brushes heretofore used. What is chiefly claimed for it by its inventor is, that it facilitates his work by shortening greatly the time consumed in the execution, and that it is

more durable than crayon or pastel when used in imitation of those styles. Artistic displays of freedom of touch can readily be added over the finished work of the air-brush by those who prefer to do so, and still the work will appear homogeneous in method of execution when the same pigments are used in both cases.

One of its merits, is that tints laid on by means of the air-brush possess the advantage of appearing equally well whether the light falls on them from one side or the other. This is not the case with tints made with the crayon, as is well known, for the reason that the toothed surface of the paper gets more completely covered on the side towards the light than it does on the shaded side, consequently, a drawing that appears smoothly finished in the light in which it was drawn, is apt to look rough and coarse when viewed with the light falling on it from the opposite direction. The reason of the difference is obvious — the air-brush throws the color directly down into the pores of the paper, covering equally both sides of the projecting tooth of the surface, so that naturally the work looks well in whatever light it is shown.

The manner in which the air-brush delivers the color to the paper may be described in few words, thus: the artist supplies liquid color from a brush to a spoon-like reservoir. Through this liquid a fine needle darts rapidly back and forth, its wetted point being carried forward beyond the edge of the spoon. A strong current of air blown against this needle's point carries off the small amount of color adhering to it in finely divided particles, thin and fine at the point of departure, but widening out as its distance increases. Hence, if the instrument is held near the paper, it will make fine lines, when moved as in writing, but removed to a distance, it will make broad, soft tints with gentle blendings. The greater or less length of stroke of the needle, as well as the current of compressed air playing on it, is all the time completely under the control of the artist by action of his thumb while working, the supply of air to the chamber being pumped in by action of his foot.

We have only to add that this remarkable invention is an important aid to the artist, and we believe it deserves the highest award that the Franklin Institute has in its power to bestow.

John Sartain, Chm.,
John Carbutt,

November 3, 1886.

Amended to incorporate the award of the Elliot Cresson Medal, and as so amended adopted. H. R. Heyl, Chairman.

As a result of such a diverse marketing campaign and the important recognition by the Franklin Institute, it is not surprising that Walkup's airbrush had a great deal of success in its early years. It is known that twelve employees were hired by the Air Brush MFG. Co. "with an annual pay-roll of \$5,500" (Browne, 1891, p. 49). The company had a prosperous business of \$20,000 annually, and it even founded an art school devoted to the teaching of airbrush techniques¹⁴. The Air Brush was also quickly recognised outside the borders of the United States. Within a few months since the founding of the Air Brush MFG. Co., Wilson (1884c, pp.30-31) notes that the airbrush started to be "a great

¹⁴ Further detail on that school is presented in chapter 2.

novelty amongst English and Continental photographers”. Few years later, Bennett (1892, p.10) announces “a shipment of Air Brushes” had been made to the Orell Füssli Institute of Art¹⁵ in Zurich, Switzerland. Nonetheless, the Air Brush was not as widespread as in the States. This can be perceived from a letter sent to the Air Brush Company by Annie E. Blake who reported that the Air Brush had “at present made no headway in England” (Bennett, 1892, p. 9).

1.6 A next generation of the airbrush and the end of Walkup’s Air Brush

Despite all that success the Air Brush Manufacturing Co. achieved, its golden years came to an end by the early 1900s. The competition started earlier in the last decade of the 19th Century, particularly in 1893 as a company called Thayer and Chandler, founded by Norwegian Henry Thayer and Englishman Charles Chandler, introduced a new and different airbrushing instrument. That instrument bore a slightly different title: Fountain Air Brush. Thayer and Chandler started off their business in 1880 as suppliers of art materials (Penaluna, 2003, p. 343). They adopted a spraying instrument prototype made by Charles Laurence Burdick. The latter designed an internal mix airbrush (Figure 10), which made it the direct ancestor of today’s airbrushes (Figure 11). He registered a number of consecutive patents of resembling updates to his airbrush between 1889 and 1921.

(No Model.)
 C. L. BURDICK.
 AIR BRUSH.
 No. 474,158. Patented May 3, 1892.

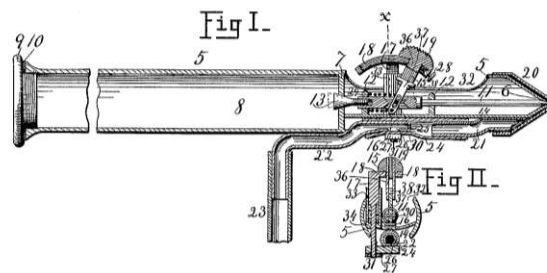

Figure 10: a patented Burdick’s Air Brush (Burdick, 1892)

¹⁵ Now called Orell Füssli Holding, was founded in 1519 as a printing company in Zurich. It later became the government printing press. In 1890, it ‘converted into a public limited company under the name ‘Art. Institut Orell Füssli Ltd.’ The company, from 1911 became responsible for printing the national banknotes in Switzerland.



Figure 11: an early Aerograph model by Charles Burdick (courtesy of Andy Penaluna)

Thayer and Chandler Co exhibited their new airbrush in the World's Columbian Exposition of 1893 in Chicago, at which Walkup's airbrush was also exhibited. Their employee Olaus C. Wold, a Norwegian-American who later established his own brand, was the one who fabricated the exhibited Thayer and Chandler airbrush based on Burdick's model (Penaluna, 2003, p. 350) which was in turn an upgrade of an earlier prototype patented by Burdick, based on the already marketed Walkup's model (Penaluna, 2003, p. 359). However, that new Fountain Air Brush exhibited at the World's Fair "was well received by the judges... and went on to win a medal with an accompanying certificate" (Penaluna, 2003, p. 351)

Walkup, however, tried to keep his rivals' business away from the trade name of his device 'the Air Brush' via legal action. It is evident that The Air Brush Manufacturing Co. filed a legal case against Thayer and Chandler Co., their only established competitor at that time in Chicago, claiming owner rights of the trade mark 'the Air Brush'. A news column in *Chicago Daily Tribune's* issue of the 26th of December 1895 provides information about "a trade-mark suit" to come up in the following month in the Federal court (Chicago Daily Tribune, 1895, p. 9). It goes on saying that the intended dispute is about the trade mark rights of "a device used all over the world... known as the Air Brush." The news article then gives the reader some information about the device itself, and mentions that it received appraisal at the World's Fair as it was "a source of interest to crowds of visitors." The article goes on saying that all of such devices are called airbrushes in the market, despite the fact that each brand was "prefaced by a distinctive name selected by each particular later manufacturer" (e.g. the Fountain Air Brush). Accordingly, "original manufacturers protested against the use of the trade-mark they had registered, and finally filed suit against their principal competitor" the article states, implying Thayer and Chandler Co. as the "principal competitor" of the Air Brush Manufacturing Co, whose "bill alleges an infringement of trade-mark and asks an injunction and an accounting."

However, Thayer and Chandler Co. knew how to make their defence. The news article conveys the company's response to the case as that "the trade-mark is descriptive, and therefore, under the rulings of the courts, not good." Thayer and Chandler Co.'s lawyer was quoted in the same article: "The

business is growing constantly and new uses will be found for the air brush... If the suit upholds the validity of the trade-mark it means the other manufacturers must sell their wares under a different title than air brush, and it is hard to see what title can be selected. An air brush is that and nothing else, and no other title for these purposes describes it.”

Unfortunately for the Air Brush Manufacturing Co., by the time their competitors’ internal-mix airbrushes became unrivalled by the now-old-fashion Walkup’s external-mix airbrush. That, combined with severe economic depression and a big fire following the World’s Fair of 1893, negatively affected the growth of Walkup’s company until it was closed in the 1900s, although records show that Liberty Walkup tried to make attempts to save his business, and he had filed at least three more patents, one for an ‘Air-Pump’ (Walkup, 1905) and the other two are for two airbrushing devices (Walkup, 1906), (Walkup, 1916).

Seemingly for Thayer and Chandler Co. in order to avoid other disputes, they realised an agreement with Charles Burdick. The agreement allowed the former to continue “to market and develop the Fountain Air Brush in the United States,” while for Burdick would look to Great Britain and her empire to sell the instrument. Accordingly, in 1893, he set up a new business at 8-9 Clerkenwell Green, London, which he called the ‘Fountain Brush Company’” (Penaluna, 2003, pp. 353–354). Burdick later adopted the word ‘Aerograph’ as the trade name for his device (Figure 12), the trade name that remained for many years a generic term for airbrushes (Chilvers, 2009, p. 9).

The AeroGRAPH
REGD
TRADE MARK

To Photographers

It is hardly an exaggeration to say that the AEROGRAPH is today as necessary to the photographer as a dark room.

For working up photographic enlargements, vignetting, filling in backgrounds, obliterating unnecessary details, intensifying high lights, perfecting contours, etc., the AEROGRAPH is absolutely indispensable.

Also for adding natural color tints without obliterating the photographic basis and for retouching photographs of machinery, furniture, etc., the AEROGRAPH is the ideal instrument, being far and away more practical and efficient than the brush.

THE COMPLETE APPARATUS
Pattern "A" 20th Century Model

Consisting of AeroGRAPH Handpiece, Foot-pump, Reservoir for Compressed Air, Air Gauge and the necessary rubber tubing. The Foot-pump has been specially designed to furnish compressed air with the least exertion on the part of the operator.

Electric Motor Air-pumps supplied in three sizes, particulars on request.

Every outfit is thoroughly tested and guaranteed for one year against any imperfection of material or workmanship.

Instructions for setting up and using the apparatus are sent with each set.

FULL PARTICULARS ON REQUEST

THE AEROGRAPH COMPANY, Limited
Inventors and Pioneers of the Air Brush 43 Holborn Viaduct, LONDON, ENGLAND

Figure 12: an advertisement of the AeroGRAPH Company in England founded by Charles Burdick (Stine, 1920, p. 146)

Burdick's efforts seemingly earned him recognition. On 15th of March 1894, an article published in the Londoner newspaper 'The Morning Post' describing, with very informing details, a presentation made by Charles Burdick to the Society of Arts aiming to show the technical abilities of his Fountain Air-Brush, or the AeroGRAPH afterwards, combined with his own artistic skills as "an artist of some repute and ability":

THE FOUNTAIN AIR-BRUSH.

At the Society of Arts last evening Mr. C. L. Burdick gave some remarkable demonstrations of his recent invention, called the "Fountain Air-Brush," which he explained in a lecture. The instrument, he said, was one for making pictures or drawings by spraying colours on paper or other surfaces. It was in the form of a pencil or fountain pen. The colour was held in a receptacle near the point, and the pressure of air (from an air-pump worked by the foot) was communicated to the pen by an indiarubber tubing, the spray being regulated by pressing a small button with the finger. With the pen near the surface a fine line could be obtained, at a greater distance a broader line, and still further away a lighter and broader shadow. He confidently expected that the instrument would replace the brush, since by its use effects could be obtained which the brush was unable to produce. There was perfect control of the amount of colour distributed, and the uniform character of the spray was another essential quality. Air was softer and more flexible than hair, and did not disarrange the particles of colour after they had been deposited. The current could be so manipulated as to produce varying lines and shadows, which the ordinary artist's tools could not command. The motive power was compressed air, and this was charged with colour on passing through the air-brush. The particles of colour were deposited on the paper in the form of a very fine stipple, and the work was therefore remarkably transparent. One layer of colour might be put over another without disturbing the first, and different tints could be obtained by thus covering one primary colour with another. The tints, however, could be mixed in the brush itself, or could be prepared before charging the brush. There was no tool that could equal the air-brush for delicacy of tints. Lines of any degree of sharpness could be obtained, and the artist could go from line to shallow, or from light to dark, without changing his tool. Thus from its facility of expression he claimed that the air-brush tended to encourage original or ideal work. Mr. Burdick made several drawings with extraordinary rapidity, demonstrating the ease with which delicate modelling could be effected. His lecture and demonstrations were much applauded, and he received a hearty vote of thanks at the close.

Later in November of that same year, 1894, another reference was given by another Londoner periodical (*Hearth and Home*, 1894, p. 883) about the Burdick Air Brush which was exhibited in an "interesting exhibition of artificial light photography at 6 Farringdon Avenue." Such news indicated faithful endeavour done by Burdick to make of his Aerograph a successful business.

In 1904, another Norwegian-American called Jens Andreas Paasche started a business making his own model with the brand name 'Paasche'. Other important airbrush manufacturers followed later in the 20th Century; Iwata in 1926 and Badger in 1964.

1.7 Early Opposition to the Air Brush

There were opponents to the airbrush who seem to have expressed their opposition as soon as they knew about the product. Ellsworth (1903, p. 139) mentions that Walkup's airbrush "has met with much opposition and criticism by artists on account of its being, so called, machine work". However, according to Ellsworth, the Air Brush Company "has been successful in overcoming this opposition".

This early opposition has been defended against by the manufacturer who described it as an “ignorant prejudice” by those who were “against anything which tended to reduce or save labor” (*Description and Price of the Air Brush*, 1884, p. 4). In the following editorial Wilson (1884b, p. 173) also strongly defends the airbrush against such a prejudice:

We cannot see how the air-brush instrument can become an instrument "for cheapening work and producing results which will not be artistic." The real fact of the case is, that it can only be used by an artist who has ability to think. At a recent meeting of the Illinois Photographers' Association Mr. McEntree, of the Air-Brush Company, demonstrated the use of the instrument, after which the managers visited the collection in the rooms of the Bohemian Art Club. The result of this was the gathering in of the opinions of several leading artists, and the approval of many photographers, portrait painters, and others. Even those who have been heretofore prejudiced against mechanical appliances that would conflict with or weaken the free hand of the artist, have accepted this new-born novelty, and are free in their unqualified praise of it as a rapid-working auxiliary in the hands of artists who work in crayon and liquid colors.

This text written by Wilson reveals one example of objections against airbrush. The objection claimed that airbrushing makes an artwork ‘cheap’ and not ‘artistic’. Penaluna (2003, p. 292) mentions Frank L. Smith, a photo-retoucher from Wisconsin, who ruefully notes: “there is perhaps no tool, that has ever been invented for the help of the artist, that has received so much abuse as the Air Brush.”

Besides merely rebating the airbrush by its haters, Penaluna (2003, p. 296) mentions that there were also artists who hid or denied the use of the instrument in their work. One reason could be that they tried not to reveal their “secrets”, but the other reason suggested is some airbrush artists were merely scared of the reaction of the audience against their work. Obviously, this negative attitude towards the airbrush in its early stages existed well into the Twentieth Century. Penaluna mentions what Sen-gye Tombs Curtis (a professional artist) has told him. Curtis told Penaluna (2003, p. 297) that when he was on a visit to the Tate he noticed that “a significant amount of airbrushing was in evidence amongst the more traditional painting approaches.” However, the curator of the museum did not want to believe such a fact until Curtis showed him specific examples. Many fine artists seem to have declined the use of the airbrush for several decades towards the Twentieth Century, as the British artist Michael English believes that the mechanical nature of the airbrush “still offends many traditional artists and those who hold traditional views about painting” (Martin, 1983, p. 13).¹⁶

¹⁶ In another example from the experience of the researcher, and being in close contact with academic institutes of fine art in Egypt as a student and then as a member of the academia since 1996, the use of the airbrush is almost never been taught or encouraged among Painting Departments at those institutes, while it is extensively used in other departments such as those of Interior Architecture and Graphics.

On the other hand, many of those who had run photography studios in the late 19th Century were far more inclined to adopt the airbrush for their business. They apparently have found the airbrush a useful tool for retouching¹⁷ and manipulating their photographic prints, in a bid for more satisfaction to their customers. The airbrush also facilitated to them the making of the photo enlargements that they used to execute with materials like crayon and inks with camel-hair brushes for their customers portraits' photographs. "The groundwork for photographic retouching was laid when the Swiss painter and photographer Isenring attempted to improve high-lights on some daguerreotype portraits c. 1841, and techniques have been seen to have been advanced through the introduction of crayon and airbrush," (Penaluna, 2003, pp. 432–433). Indeed the airbrush had become, by the end of the 19th Century, a favourable tool in the photo-retouching market that at that time had already become an established business at many photography studios and retouching factories across the United States (Kate Chase, 2012). That is evident by those many newspaper advertisements from that period of time that had been proudly announcing the use of the airbrush (Figure 13), seeking professionals of retouching with the airbrush to be hired (Figure 14) or even looking for for second hand airbrushes (Figure 15).



Figure 13: an advertisement by a photography studio claimed that they were the only in the city “using that magic tool, the air brush”. This advertisement was published in *The Herald of Los Angeles* (1893, *Chronicling America - Library of Congress digital archive*, p. 8)



Figure 14: Used Air Brush Wanted; an advertisement published in *St. Paul daily globe*, Minnesota (1887a, *Chronicling America - Library of Congress digital archive*, p. 8)

¹⁷ It should be noted here that the word ‘retouching’ in this context means editing photograph prints (usually to enhance their photographic quality for the sake of customers’ satisfaction). Therefore it must not be confused with the same word found in the context of the image reintegration of paintings.

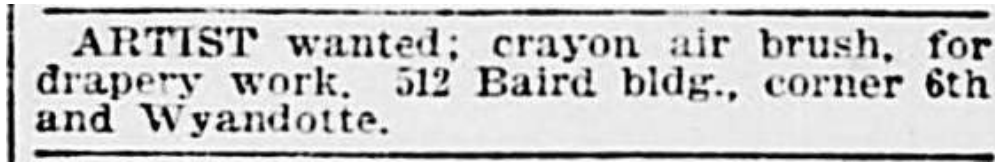

Figure 15: Air Brush Artist Wanted; an advertisement published in *Kansas City Journal* (1899, *Chronicling America* - Library of Congress digital archive, p. 18)

The airbrush, however, found in the late 19th Century and early 20th Century, several advocates who wrote articles, book chapters and even books about that device. For example, a writer called Samuel W. Frazer published a book in 1915 titled 'Treatise on the Air Brush' in which he says: "The air brush has been greatly misunderstood by artists who have never used it and by some who have, as a consequence of not being able to master its use" (Frazer, 1915, p. 7).

Similarly, another writer called George F. Stine published a book in 1920 titled 'The Air Brush in Photography' in which he wrote an advice to the opponents of the airbrush: "if those who have condemned and never tried this valuable instrument, or simply tried it in a careless or indifferent way and failed, would devote a few spare moments each day to its use in an earnest, studious effort, they would find in a very short time that work can be done in a few hours that without its aid would take weeks or possibly even a greater time to produce" (Stine, 1920, p. 15).

Despite the negative feedback by the airbrush opponents since it was first marketed, the little instrument apparently made it through, and by the 1930s, as noted by R. Johnson in his 13th edition of 'The Art Of Retouching Photographic Negatives': "the use of the airbrush has become almost universal owing to its efficiency and speed" (1936, p. vi). "In 1949," says Garner (2008, p. 82) describing a 1949 advertisement (Figure 16) by the Aerograph Company, "the Aerograph is spraying an image of the Earth. It is being used all over the globe."

1.8 Conclusion

The present chapter has ventured into the early history of the airbrush. This chapter has traced back the first airbrush model to have been introduced to the market by Liberty Walkup who founded his Air Brush Manufacturing Company in April 1883. Walkup's airbrush was based upon Abner Peeler's earlier prototype called the Paint Distributer. That prototype and other earlier spraying devices have been explored in the present chapter.

This chapter has also demonstrated the extensive marketing campaign made by Walkup's company for their airbrush. That campaign helped in gaining good publicity for their product and eventually led to praise and recognition from several parties including Photographers' Association of America and the Franklin Institute in 1887 and 1888 respectively. However, there have been others who were not

satisfied by the airbrush. Opposition against the airbrush and how it was defended against by the airbrush makers and users have also been mentioned in this chapter. Additionally, this chapter explains the declination of Walkup's airbrush prototype in favour of newer and improved versions from other brands emerged in the late 1890s that started to produce airbrushing devices similar to those available today.

The next chapter explores the history of the airbrush in the context of fine art and its gradual acceptance by artists.



Figure 16: a 1949 advertisement by The Aerograph Co. Ltd. claims: “Aerograph Air Brushes Are Used All Over The World.”

Chapter 2 – The Role of the Airbrush in the Field of Fine Art

2.1 Introduction

The previous chapter looked into the early history of the invention, early development and marketing of the airbrush. This chapter can be seen as a bid to look specifically into the nascent linkage between the airbrush and fine art painting. Specifying fine art painting in this context is intentionally made in order to distinguish it from other forms of art, such as illustration, in which airbrushing has been extensively exploited. Accordingly, the research is basically interested in artists whose artworks are classified as paintings and who have effectively used the airbrush in their artworks. As will be further discussed in this chapter, when the airbrush was introduced it created tension within fine art circles with regard to its use in fine art. Consequently the airbrush created a certain degree of controversy between the proponents and the opponents of the use of the airbrush in fine art painting.

The idea of spraying paints to create drawings is deeply rooted to prehistoric time. It is generally agreed that numerous primitive wall paintings – such as those found in a number of prehistoric caves like Lascaux and Pech-Merle in France – are likely to be spray paintings. They had been executed either by blowing paints directly from the mouth or through a hollow reeds or bones. Wakerman (1979, p. 15) metaphorically describes those cave paintings as “the earliest instance of airbrush art”. In Seventeenth-Century Japan paint-spraying techniques were known among painters and printmakers, though with simple tools. *Fukibokashi* and *Kirifuki* were similar methods of spraying paints either directly from the mouth or by blowing through a tube (Bell, 2004, p. 247). Masking was used to cover areas desired to be left uncoloured. Such techniques were useful to create certain effects, for example to depict snowfall or splashing-waves sceneries. Perhaps it is interesting to mention in this context that Toulouse Lautrec (1864-1901), who was influenced by Japanese art, used a similar technique called *Crachis* to create mists of colour in his lithographic prints. Many other French artists contemporary to Lautrec are known to have also used the same method (Wittrock, 1985, p. 36).

In modern times airbrushing proved to be unique amongst the other artistic techniques as it is the only method which does not require a direct physical contact with the substrate. Drawing and painting with tools like paintbrushes, pastels or pencils would obviously be impossible without the tool directly touching the surface – except if one argues that brushes can be used to ‘spatter’ paints. By all means, however, no one would consider the latter a controllable way to apply paints on a substrate. The airbrush is based on the same principle of that found in other spray systems, such as aerosols. However, the controllability of the airbrush makes it favourable to artists who want to employ the spraying technique in their artworks.

The airbrush has been exploited in many paintings by numerous fine artists of the Western World into the Twentieth Century. However, it is noteworthy that the literature which considers the use of the airbrush in fine art painting is very limited. In fact, most of that literature has been mainly dedicated to the technical aspects of the airbrush. It might also be surprising to note that several well-known published sources on the materials and techniques of fine artists never mentioned the use of the airbrush in the context of fine art paintings, or even mentioned it at all. This observation has also been made by Penaluna (2003, p. 10) who notices that “traditional art reference books frequently ignore the airbrush. Gombrich's best seller *The Story of Art* has no reference whatsoever to the airbrush, neither has Phaidon's popular text, *Encyclopedia of Art and Artists*.” Ralph Mayer's *The Artist's Handbook of Materials and Techniques* which is described as ‘the Artist's Bible’ very briefly mentions the airbrush in the book's fifth ‘revised and expanded’ edition of 1991¹⁸.

2.2 The Illinois Art School of 1888: the first school for airbrush

From the very beginning of their business, and in a bid to reassure their customers, the Walkups' Air Brush Manufacturing Company offered training lessons at no additional cost. The company asserted that they “do not teach art, but give instructions” on the “handling and operating of the Air Brush” (*Description and Price of the Air Brush*, 1884, p. 22). Buyers, who were located at some distance from Rockford, were supposed to be able to use it using the instructions in the booklets published by the Air Brush Manufacturing Company. Penaluna (2003, p. 268) notes that, at least until 1886, the pamphlets published by the Air Brush Manufacturing Company were the “only source of instruction”.

As demand increased, the Air Brush Manufacturing Company opened a studio for which they also hired a professional artist to work as a tutor. Penaluna (2003, p. 270) describes that the studio was “a successful extension” of the company. Conclusively, that ‘extension’ was called the Air Brush Art School as mentioned in an Ohioan newspaper called *Springfield Globe-Republic* (1886). Interestingly, this is mentioned in the context of a brief report on the return of one of the studio's students from Rockford to Springfield. It is reported that the student, whose name was Morton Penfield, “spent the past three months, pursuing his art studies” at the Air Brush Art School, and “he made rapid progress.” (*Springfield Globe-Republic*, 1886) It is found that the company made the programme of study flexible. The students were allowed to choose the number of lessons they desired and they were also allowed to choose the time they wanted to start their studies. The studio did not only offer training on the Air Brush. “Any branch of drawing or painting from objects or life” was offered to students as desired (Penaluna, 2003, p. 269). Moreover, the Air Brush was not a compulsory subject, it was also offered free of charge to those who wanted to learn how to use it.

¹⁸ Mayer, R., & Sheehan, S. (1991). *The artist's handbook of materials and techniques* (5 ed.). London: Faber and Faber.

The company later hired ‘agents’ who set up tours to show those interested in the Air Brush, how to use it. An advertisement in a newspaper that was circulated in Milwaukee – around 90 miles away from Rockford, Illinois – states: “H. F. Brainard, artist and agent for Rockford Air Brush, is in the city for a few days and will give instructions to purchasers of the brush and also paint a few portraits for those wishing the same for half price to advertise the brush.” (The Milwaukee Sentinel, 1885). The Air Brush Manufacturing Company had obviously made every effort they could to reach prospective customers.

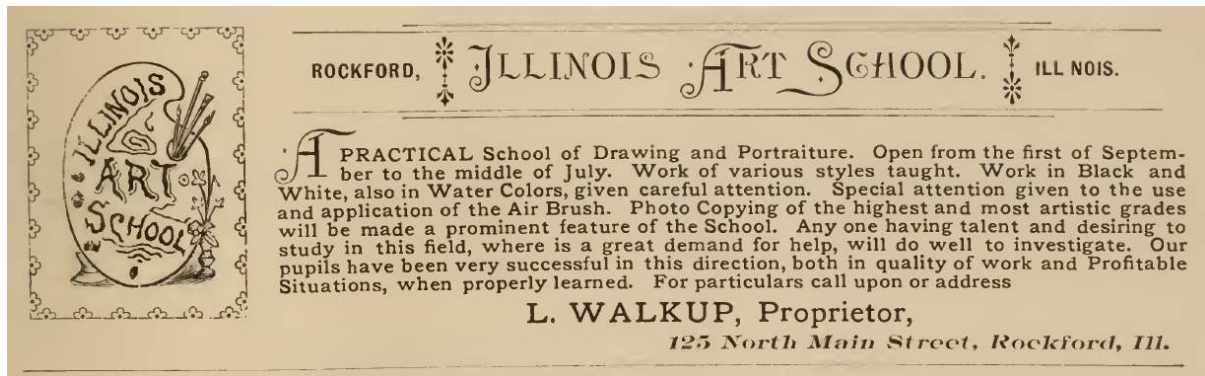

Figure 17: an advertisement for the Illinois Art School (Beloit College, 1892, p. 3)

The demand for the air brush lessons was so great that a decision was made to establish an art school to teach airbrushing to those interested. In July 1888, the plan to open a large art school in Rockford by Walkup was announced in the news (Penaluna, 2003, p. 270). Enthusiasm for the product seems to have been high as a local newspaper called ‘Rockford Morning Star’ optimistically announced the upcoming Illinois Art School: “Good thing for Rockford... It will be a big thing for the city and the Air Brush, bringing students of art to Rockford from all parts of the country.” (Penaluna, 2003, p. 271). The Illinois Art School was founded in September 1888, headed by Liberty Walkup who was supported by his wife Phoebe Walkup (Spencer, 1998) (Figure 17). Browne (1891, p. 49) says that the school was established in Rockford and “connected” to the company’s building. However, we learn from contemporary news that although the Air Brush office remained in the same place, the art school was in “a separate and new enterprise” (Penaluna, 2003, p. 271). Lessons on instruction in the use of the airbrush were, of course, a significant part of the curriculum. Walkup’s wife, Phoebe¹⁹, who was also a skilful artist, taught the use of the air brush to the students of the Illinois Art School. Surprisingly, we learn that the lessons on the Air Brush were not immediately included in the curriculum. A local newspaper called ‘The Register’ – in a special visit to the Illinois Art School –

¹⁹ According to *Portrait and biographical record of Winnebago and Boone counties* (Biographical Publishing Co., 1892, p. 515): Mrs. Walkup, formerly Phoebe C. Johnson, was “a gifted artist, and has executed some fine work with the air-brush, besides assisting her husband in a material way in his discovery”.

reports that “Drawing oil and water color painting, various decorative works, photo copying and enlarging are made special features. In the latter branches the Air Brush will be employed.” An issue of the ‘Frank Leslie’s Illustrated Newspaper’ from 1889 dedicated an article to talk about the City of Rockford, Il. The Illinois Art School was chosen amongst eleven of the distinguished establishments in the city in the reporter’s opinion:

“The Illinois Art School offers advantages to young persons who have artistic ability which they wish to turn quickly to account in earning a living... The school merits the patronage of young persons of artistic tastes and capacity.” (Clair, 1889, p. 375)

Clair (1889, p. 375), the reporter who wrote this article, presumably wanted to justify the reason behind the choice of the Illinois Art School to be talked about, so he states: “Rockford has 130 mills and factories, of which the leading ones are deserving of special mention.” It is interesting to note that this school has been looked at as an establishment which is “deserving of special mention’.

We are also informed by ‘The Register’ that two ladies have been brought to teach at the school. One of them was Miss Carrie W. Harper from Washington. The newspaper tells us that she studied art in the US and “abroad” (Penaluna, 2003, p. 275). The other instructor was Mademoiselle Nearn from Paris. We notice that the newspaper exceptionally expatiated on the background of the latter instructor, as it states that “this lady was educated in the finest schools of the old art world, and has taught successfully in art schools in Paris. She has had rare opportunities for the cultivation of a knowledge of art.” This description sounds overstated and is probably meant to be a hidden and clever form of advertising aimed at enticing prospective students into attending the art school. Further to this information, we are also informed that, through an interview with Liberty Walkup, additional tutors were to be employed in the school. Later, in the first issue of ‘The Air Brush Journal’ of January 1891 we learn that a new instructor, Miss Josie Pickard, was appointed in the Illinois Art School (Penaluna, 2003, p. 285). Walkup also announces that further equipment and materials are to be provided to fulfil the requirements of fifty students who were expected to be enrolled in the autumn of 1888. According to this evidence from contemporary news reports supported by an advertisement published in the ‘Rockford City Directory of 1889–1890’ which highlights the “Use and Application of the Air Brush” as a central feature in the curriculum of the art school, Penaluna (2003, p. 276) concludes that the Illinois Art School began; “the first ever Air Brush classes... in the first weeks of September 1888.”

It was claimed that The Illinois Art School was “being attended by a fine class of students from every State in the Union, Canada, and some countries in Europe.” (Biographical Publishing Co., 1892, p. 515) Some of the names of the students are mentioned with high praise in an issue of ‘The Air Brush Journal’, such as Alfred Johnson of Winsor, Nova Scotia, Henry Verwayne, of Evansville, Indiana,

Miss Alice Jones, of Byron, Illinois, Miss Cowen, of Pana, Illinois and C. O. Pearson, of Fairmount, Indiana (Bennett, 1892, p. 11). Interesting notes have been enclosed in the same issue of 'The Air Brush Journal' regarding the Illinois Art School. For instance we are informed that "summer term ends July 16th. Fall term opens first Monday in September." And we learn that during the prior year, 1891, "about one hundred students have been enrolled." There is also a note which acclaims a student for his early success in the art market: "A. J. Lohr is more than paying his expenses while in school by the orders he has taken." (Bennett, 1892, p. 11)

In the same issue of 'The Air Brush Journal', there is an advertisement about the Illinois Art School which states that "the scope of the school is similar to other good academies of art and design". The advertisement also claims that the aim of the school is to be "thoroughly practical", and states that "freehand drawing... photo-copying and enlarging" are taught and "special attention given to water-color work." (Bennett, 1892, p. 17) Furthermore, Penaluna (2001) believes that the school was set up especially "to teach techniques associated with the Airbrush". The school apparently had a strong start as implied by brief news reported from an exhibition of photographs at the 'Minneapolis Convention' in July 1888. The Photographic Times' reporter (1888, p. 349) says that "the air-brush, charcoal, crayon and Indian ink work exhibited by the Illinois Art School. Rockford, Ill., was a credit to that school." (Figure 18)



Figure 18: an advertisement of the Illinois Art School (The Sunday School Times, 1890, p. 220)

This advertisement in (Figure 18) interestingly shows a different way to attract students. The advertiser tries to persuade prospective students by pointing out that they could "spend the summer vacation profitably" if they joined the art school. Similarly, this way of promoting the school is found in the following paragraph:

It [the Illinois Art School] makes a speciality of teaching the use of the air brush in photo copying and enlarging, and the record of the financial success of its pupils, many of them young women, proves that it gives what it offers to give – a practical means of earning a living. (Clair, 1889, p. 375)

Other advertisements of the school went further, Penaluna (2003, p. 307) quotes from the 'Air Brush Journal' of April 1892: "Aesthetic Ideas Will Not Butter Bread, Practical Work Will and Set Sauce Beside it." Another advertisement states that the school offers "those with artistic ability a way to turn their gift into making a bank account." Penaluna also notes that a claim has been made that the use of the airbrush would bring a weekly income of about \$40 which is equal to that earned each month by art teachers at the time. Other comments have been made by the Air Brush Company through its journal to point out to those who were previous students of the Illinois Art School and now successful in business:

"Miss Emma Johnson is at Michigan City with Houser, in a photographic studio. They were both students in the Illinois Art School last spring." (Penaluna, 2003, p. 285)

"Mrs. G.F. Sterling formally a student in the Illinois Art School is now making the Air brush an indispensable part of the G.F. Sterling Photographic Studio of West Bay City, Mich." (Penaluna, 2003, p. 286)

It is a fact that The Air Brush Company often tried to attract both its prospective customers and students by talking practical. It kept focusing on the potential good earnings and profitable jobs that could be achieved through the use of the airbrush by learning of the airbrushing techniques. This is clear in the following statements quoted from the 'Air Brush Journal' (Penaluna, 2003, p. 290):

"Students have succeeded so remarkably that they have been able to take situations and give satisfaction in studios at large salaries. Constant calls for more help whenever the work is known, enables the proprietors to offer lucrative positions when students are competent."

"By the use of the Air Brush hundreds who have artistic talent have been enabled to take a step up in life to make money and build homes. It is far more remunerative than book keeping, type-writing [sic] or a score or more of the crowded positions of today."

This type of claim, however, proved to be true as implied by the advertisements found in newspapers from that period published at different cities in the US asking for qualified airbrush artists, mostly promising stable jobs and good salaries. The following quotes are examples of those advertisements:

"Wanted – A first-class air brush artist: wages \$35 per week. Inquire of George E. Bell, portrait artist" (Wichita Eagle, 1889)

"Artists – Two first-class crayon air brush artists: steady work and good pay. Electric Copying Co." (Pittsburg Dispatch, 1891)

"Artists – wanted, experienced air-brush artists; steady employment; good pay. Apply between 11 A. M., to The Sprague and Hathaway Co." (The Evening World, 1893)

“Wanted – At once, 3 competent air-brush artists; steady work guaranteed to competent men. W. McClellan & Son, cor.” (The San Francisco Call, 1896)

“Wanted – at once, 2 lady air brush artists; \$18 per week; steady work. H. M. Wigner.” (The Evening Times, 1898)

“Air Brush artists. First-class, would like work on crayon and pastels. M. E. Folsom.” (New-York tribune, 1898)

These examples of job advertisements clearly show that photo enlarging and retouching had gained much in popularity. Penaluna (2003, p. 200) says that from the very beginning of the business of photo retouching, the airbrush offered opportunities for “many lesser artists” to be hired. Their task was to ‘improve’ enlarged photographs in which imperfections occurred in the process of copying from the originals.

On the 9th of November 1895, a very unfortunate incident occurred in Rockford. Several businesses were hit by a “serious fire” or a “big blaze” as described by the newspapers which reported this incident at the time. Details of the causes and aftermaths of the fire were reported by ‘The Daily Inter Ocean’ of Chicago:

Fire broke out in the brick block on North Main owned by C. F. Henry street at 10:30 o’clock. The blaze originated from an explosion in the basement of Harper & Johns’ paint and art store... The first explosion was followed by several others later, but no one was injured... The entire second floor was occupied by the Northern Illinois Art and Air Brush School, the latter having many costly paintings and works of art. There was no time to remove any of the goods from the building. (The Daily Inter Ocean, 1895, p. 4)

Several sources from contemporary newspapers confirm the details of this unfortunate accident. It seems to have been disastrous to those who, at the time, had businesses in the Henry block. This can be clearly imagined as we learn that the total loss was estimated to a figure of about fifty thousand dollars, covered with insurance of only \$21,000. The Illinois Art School was not an exception as its total loss was about \$2,000 covered with insurance of \$1,500 (The Commercial Appeal, 1895, p. 3). It is also very likely that this fire was catastrophic to the Air Brush Company because of the investments put in its premises in the Henry Block only four years earlier. In July 1991, according to Penaluna (2003, p. 298), ‘The Rockford Daily Register Gazette’ reports that the company “made a move into the second floor of the Henry Block”. That new extension included a new place for the art school alongside other businesses in which the Air Brush Company was involved, such as a new factory for making the Air Brush and nickel plating. This was already a hard time for Liberty Walkup whose business began to be threatened by new competent rivals. In such circumstances, no doubt this fire caused more harm to the Air Brush Company and its art school. Although Penaluna (2003, p. 412)

confirms this assumption, he believes that “things were back to normal by April 1897” as both the company and the school were “given a brief feature in The Rockford Republic.”

However the Illinois Art School would appear not to survive for long after its resurrection as Spencer (1998) suggests that it was possibly closed around 1902. It is noteworthy to mention here that there was at least another art school which is known to have taught the use of the airbrush. A classified advertisement was found in an issue of a newspaper called ‘The Morning Call’ that was being circulated in San Francisco, California. The advertisement points out to an art school named ‘Wahlstad’s Drawing School’ which promotes that it teaches: “freehand, perspective, crayon portrait, air brush.” (The Morning Call, 1894, p. 4) Unfortunately no further information was found regarding this latter school.

The Illinois Art School is likely to have trained numerous artists who wanted to be able to professionally use the airbrush. Although very little is known about those trained at that school, it is suggested that Wilson Irvine (1869-1936), an established American Impressionist painter, is likely to have been one of them. Spencer (1998) mentions that, in his diary of 1888, Irvine “states in the entry for January 2 that he had worked on the airbrush in the morning. The entry seems to imply that this was not the first occasion, so it is likely that Irvine had been using this new instrument at least as early as the latter part of 1887.” Spencer also says that a Rockford newspaper, issued on 9th April 1891, described Irvine Wilson as “a successful airbrush artist in Chicago”. This led Spencer to conclude that Irvine was “among the first practitioners” of the technique of airbrushing. Irvine was, it is assumed, skilled enough to be primarily employed by the Chicago Portrait Company which was founded in 1893. At that company Irvine specialised in the retouching and enlargement of portrait photographs.

2.3 The airbrush art towards the twentieth century

In the last section of this chapter an indication was made to the importance of the airbrush, since its early days, for many of those who worked in the flourishing photography industry at the time. Therefore, it is equally important to point out first to the significant role played by photography in this context. This section also overviews the importance of the airbrush in other fields, in particular photography and commercial art. These fields became increasingly intersected with fine art from the late Nineteenth Century towards the Twentieth Century. Artists became increasingly involved in diverse artistic activities that included both commercial and fine art.

Interestingly, photography and airbrushing have been encountered with controversy from the moment of their invention. They both have been criticised and rejected by many artists as being mechanical. Photography has been otherwise deemed threatening by painters who feared their work would be

displaced by the realistic image produced by the camera. The following note from a book published in the year 1859 provides an insight to opinions contemporary to that matter:

Photography is the offspring of science, not of art; and artists have felt much disposed to regard it as an illegitimate upstart trenching upon their province, and claiming a large share of what art had hitherto regarded as its inalienable inheritance. They have thus looked upon it with something of the same spirit with which handicraftsmen in the mechanical trades have ever regarded the progress of the machinery which promised to declare their occupation gone.

However, the camera was welcomed particularly by those who were able to make a living from a range of practices based on the photography industry, such as enlargement and colouring. This is evident in the following note published in the year 1863:

Some people imagine that the Artist and the Photographer must be natural enemies, seeing how closely Photography trenches upon the province of the former; but, to a great extent, this is a mistaken notion,—they may, and ought to work together very amicably, combining for mutual benefit. When the Photographer has succeeded in obtaining a good likeness, it passes into the Artist's hands, who, with skill and colour, gives to it a life-like and natural appearance. (Rintoul, 1863, p. xiii)

Moreover, there were fine artists, such as Ingres, Delacroix and Courbet who “welcomed photography as a helpful auxiliary to painting.” (Kleiner, 2013, p. 362) A number of late 19th Century artists even effectively used photographs as references for their paintings. A number of French painters, including Gustave Courbet, Theodore Roussaeu, Edgar Degas and Pier Bonnard took up photography as part of their own artistic practice (Hannavy, 2013, p. 86). Toulouse Lautrec used photographs extensively as studies for later paintings (Davenport, 1991, p. 32). Pablo Picasso used ethnographic photographs extensively as aids to compose a number of his well-known paintings, including *Les Demoiselles d'Avignon* (Hannavy, 2013, p. 86). The American painter and photographer Thomas Eakins (1844-1916) used photography to compose numerous paintings. An important example is his drawings of motion photographs of racehorses pioneered by Eadweard Muybridge (1830-1904) (Hannavy, 2013, p. 459). Another important American painter and photographer, Charles Sheeler (1883–1965), is best known for his realistic paintings rendered from photographs of industrial scenes.

Indeed, photography became an indispensable asset in a broad range of artistic practices. Photography unprecedentedly helped reshape the traditional perception of commercial and fine art as being isolated from each other. The airbrush quickly became an important tool in the photography and commercial art industry. The flourishing of mass culture resulted from such a combination facilitated the introduction of the airbrush in the field of fine arts.

By the late 19th Century there had already been a huge interest in photographic portraits by the public in the West. Photographic prints needed further intervention either to obscure undesirable blemishes or to add some lasting touches. According to Curtis and Hunt (1980, p. 15) photographs were coloured by hand from 1860 as the colour reproduction of photographic prints was impossible before 1910 and the public wanted color in their pictures. Solar prints were a “method of producing photographic enlargements at that time,” (Penaluna, 2003, p. 44) but they had a tendency to fade and they required retouching. Photo retouching and copying and photo enlargements were in such great demand that a whole photographic industry flourished during the late Nineteenth Century. Penaluna (2003, p. 301) mentions that numerous “picture houses” – i.e. photography studios – adopted the idea of having a “good artist who was supported by less able individuals”. That good artist – who was also called a “Spot Knocker” – was responsible for airbrushing out marks or blemishes from portraits or similar fine work. His assistants – who were called “Drapery Men” – specialised in improving backgrounds in the photographs or enlargements. Kassel (2001, p. 20) mentions that “photo tinting” was another application in which the airbrush had been employed to satisfy those customers who wanted to see their portraits coloured. The airbrush remained a very important asset in this industry well into the Twentieth Century.

The airbrush became even more indispensable in another important industry relevant to the present context: illustration and graphical design. The 1920s witnessed a boom in the American advertising industry as a result of expansion in economy and growth in consumerism. By the late 1920s in the US, airbrushing techniques became extensively involved in graphical design and illustration through various forms of mass media. Wakerman (1979, p. 42) claims that airbrush illustration first appeared in 1928 in a magazine called the *New York Art Director's Annual*. She also mentions that “the first American illustrator to make the airbrush poster a popular form of advertising art was Otis Shepard.” Otis Shepard (1894-1969) was influenced by the Viennese Joseph Binder (1898-1972), who was one of the most European influential figures in the avant-garde poster art.

On 8th January 1930, *Advertising Arts* magazine published its premier issue. It was “the first mainstream attempt to integrate modern art into an admittedly antiquated commercial culture.” (Heller, 2013, p. 125) That was almost in the beginning of the Great Depression, when design became used as “a weapon in the war against stagnation,” by encouraging “consumers to consume.” (Heller, 2013, p. 126) *Advertising Arts* promoted for a newer American design style called ‘streamline’ that was less attached to the earlier European influence in this field, while the airbrush remained “the graphic medium of choice.” (Heller, 2013, p. 127)

Esquire magazine was first issue in October 1933. It became well known for its sleek and glamorous ‘Petty Girls’ drawn by George Petty (1894-1975) during the 1930s and ‘Vargas Girls’ drawn by

Alberto Vargas (1896-1982) during the 1940s. The first issue of *Esquire* magazine in 1933 featured a cartoon pinup girl by Petty, and in 1940 it started to publish pinups by Alberto Vargas. George Petty came from the industry of photo retouching as the son of a photographer. His ‘pinups’ are considered a hallmark in American popular culture. Kassel (2001, p. 20) says that Petty “had created the perfect woman out of thin air,” and that “Vargas’s name has become synonymous with the airbrush pinup.” The idealistic seductive illustrations of ‘Petty Girls’ and ‘Vargas Girls’ continued to be an American trend for almost two decades throughout the 1930s to the 1940s (Figure 19). Their use of the airbrush had certainly helped create photographically realistic, and yet appealing illustrations.

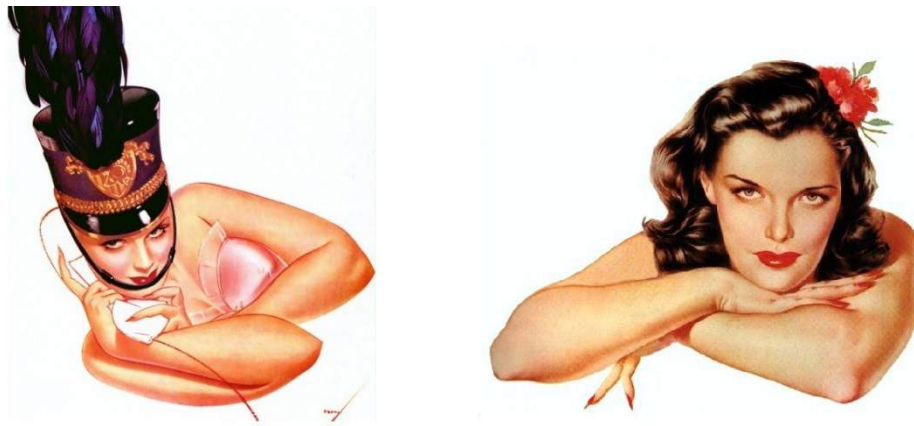

Figure 19: A pinup illustration by George Petty (left) and a pinup illustration by Alberto Vargas (right)

Despite the fact that the airbrush proved highly successful in the art of illustration and advertising for about two decades, it was “largely absent from commercial art” after WWII into the late 1950s. However, the airbrush returned strongly in the 1960s with “the resurgence of poster art and the advent of Pop Art and advertising in mass culture” (Kassel, 2001, p. 20). The following section sheds more light on the role of the airbrush in the context of fine art.

2.4 The Airbrush and Twentieth Century Fine Art

The airbrush remained, into the early decades of the Twentieth Century, to have been used essentially for illustration, graphic design and photographic retouching. In fact, it even “played a crucial role in the development of” those types of art and helped shape the popular art of the Twentieth Century (Martin, 1983, p. 8). In those early years the airbrush was gradually employed in fine art. Michael English²⁰ (1941-2009) asserts that the airbrush started to have direct and indirect influence on fine art

²⁰ Michael English (1941-2009) is a British artist who studied art at Ealing School of Art in London in the early 1960’s. By the late 1960’s “with the demise of the hippy movement and his discovery of the airbrush” English

(Martin, 1983, p. 8). The use of the airbrush in fine art painting started as an experiment. It was just used marginally to help achieve certain, and limited, effects in paintings. Commercial art of that time, on the other hand, relied to a great extent on airbrushing techniques. However, it would be noteworthy to say that such commercial art has been “assimilated and developed by fine artists”. Michael English, in this context, brings up an interesting point as he says that the airbrush in itself, although merely a tool, “illustrates the persistent division between the world of graphics and the world of traditional fine art,” although “the distinction between fine art and the graphic arts is not a matter of a simple clear definition” (Martin, 1983, p. 8).

Several modern movements in fine art in the early Twentieth Century, however, confronted such traditional views about fine art. Several fine artists, accordingly, declined traditional techniques and became more and more inclined to search for and experiment with new tools and unconventional techniques to help shape their new ideas. Kirsh and Levenson (2000, p. 137) provides examples of such artists who sought unconventional methods, and some of them effectively employed airbrushing techniques in their artworks: “Vladimir Baranoff-Rossiné sprayed paint over stencils to re-create the impression of motion and lights at the circus (Figure 20)... Siqueiros experimented with sprayed paint application as a rejection of high-art preciousness. Artists of the 1960s embraced commercial technology (via the airbrush) to the same ends.”

abandoned his old psychedelic style and shifted to a hyper-real style. By the early 1970's he “moved away from the printed form and began to paint canvasses... and developed a very personal form of true hyper realism.”
(michaelenglishart.co.uk/history)



Figure 20: “Daniel Vladimir Baranoff-Rossini. Copriccio Musicale (Circus). 1913, glue-based paint, oil and pencil on canvas. 130.4 x 163.1 cm. Hirshhorn Museum and Sculpture Garden, Smithsonian Institution, Washington, D.C.... Baranoff-Rossiné created the impression of movement and theatrical lighting by spraying point over stencils.” (Kirsh and Levenson, 2000, p. 136)

2.4.1 The 1910s

Man Ray (1890 – 1976), a notable early proponent of airbrushing, aspired to employ the airbrushing technique to his artworks. He began experimenting with the airbrush during the second decade of the Twentieth Century, the period that has witnessed the culmination of the Dada movement of which Man Ray was a member (Schwarz, 1977, p.40). Seemingly, Man Ray found in the airbrush a solution to – what was intended to be – his anti-art style by abandoning traditional techniques. Ray’s skill with photography may also have facilitated his passion with airbrushing. That was probably due to “a certain similarity of procedure between the airbrush technique and the process of printing in photography,” according to Naumann (2003, p. 184). Schwarz (1977, p.39) quotes a proclamation made by Man Ray in an interview with him: “I wanted to find something new, something where I would no Longer need an easel, paint, and all the other paraphernalia of the traditional painter”. This ‘something’ was the airbrush which Man Ray describes its ‘discovery’ as “a revelation” for him, according to his own words. It was when he brought an airbrush and air compressor to his office to finish up graphic work to he was assigned: “The inspiration came from my office, where I had installed an airbrush outfit with air pump and instruments to speed up some of the work which involved the laying down of large areas of colour. This could be done much more quickly and

smoothly than by hand. Where precise forms had to be contoured, stencils were cut out which protected the areas not to be sprayed. It was a process commonly used in commercial work. I became quite adept in the use of the airbrush and wondered if I could use it for my personal painting... I worked in gouache on tinted and white cardboards – the results were astonishing – they had a photographic quality, although the subjects were anything but figurative.” (Schwarz, 1977, p. 39)

Man Ray’s well-established background in photography led him to discover similarities between airbrush effects and photograph prints. Man Ray employed airbrush in several paintings calling them *aerographs* (Figure 21). Klüver and Martin (Foresta, 1988, p.75) say that as “Man Ray’s airbrush paintings tended to be monochromatic, it has frequently been noted that they have the appearance of photographic prints”. Despite the admiration Man Ray has shown for his results, the reaction from critics was not so positive. Martin (1983, p.20), states that the airbrush was “firmly rejected in art circles and his [Man Ray’s] *aerographs* provoked hostility and accusation”. Man Ray himself confessed: “When I began painting with the airbrush I had already been accused of debasing art by painting with a mechanical instrument” (Naumann, 2003, p.186).

Man Ray however eventually stopped working with the airbrush after a few years of experimenting with it. “The year 1919 was the climax of Man Ray’s short-lived airbrush period. After having used the airbrush for a couple of years he had mastered the medium so well that he could not resist the temptation to use anything and everything lying around in his studio as a stencil. The results were achieved much more rapidly than by painting, and were more gratifying than a simple photograph, where the re-elaboration of the model is almost nil,” says Arturo Schwarz (1977, p. 50), the renowned art scholar whom Man Ray called ‘my historian’.

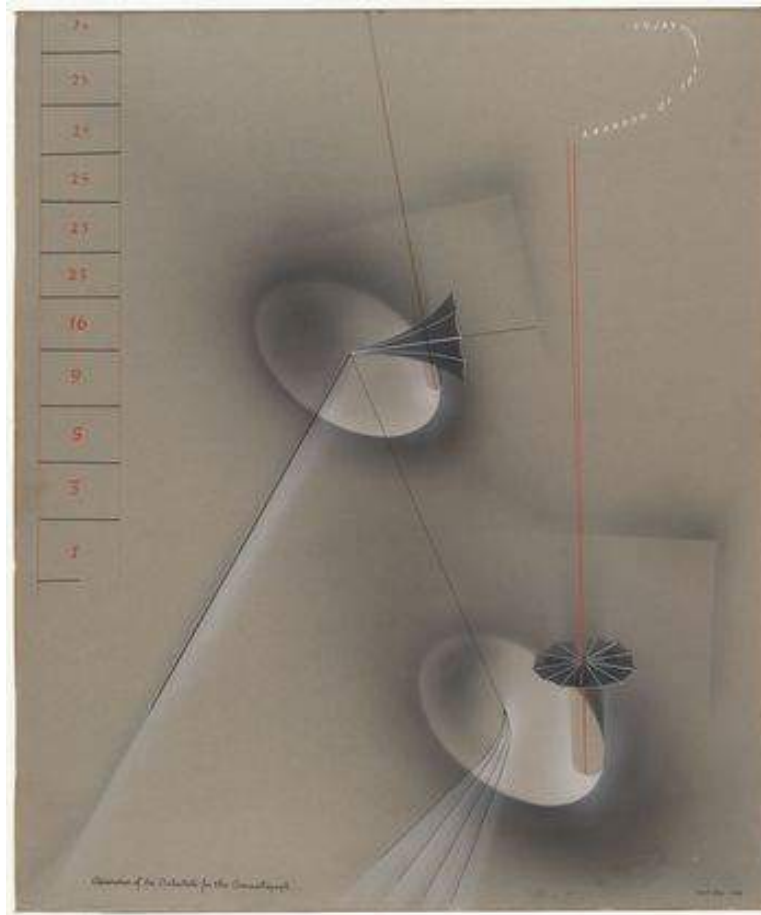

Figure 21: Man Ray, *Admiration of the Orchestrelle for the Cinematograph*, 1919, Airbrushed ink and gouache, ink, and pencil on grey paper (66 x 54.6 cm). The Museum of Modern Art (MoMA)

2.4.2 The 1920s

The German school of art, Bauhaus, had a major influence on fine art in Europe towards the 1920s. The school was established in 1919 but eventually forced by the Nazi government to close down in 1933. The Bauhaus teachers encouraged their students to seek new tools and techniques for their artworks. Moholy Nagy was one of the most prominent Bauhaus teachers at that time and encouraged experimenting with mechanical tools to help depersonalise art forms and correspond to the industrial era: “Moholy’s embrace of mechanical techniques followed logically from his wish to exceed the capacities, and eliminate the traces, of the hand” say Bergdoll and Dickerman (2009, p. 133), who then quote from Nagy: “An airbrush and a spray-gun, for example, can produce a smooth and impersonal surface treatment which is beyond the skill of the hand. I was not afraid to employ such tools to achieve machinelike perfection.” According to Michael English “the airbrush was no more celebrated at the Bauhaus than any other available technique, but it was used without hesitation or

prejudice, and formed an important strand in the visual vocabulary of artists and designers” (Martin, 1983, p. 15).

Other examples of Bauhaus’ notable teachers are Wassily Kandinsky (1866-1944) and Paul Klee (1879-1940). Both of those artists effectively made use of spray painting while experimenting with new materials and techniques. Klee started experimenting with spray-painting techniques in the early 1920s as he was probably aware of Many Ray’s Aerographs (Rewald, 1988, p. 213). *View of a Landscape* is an example of Klee’s work in which he used the airbrush (Figure 22). Kandinsky was influenced by Klee’s innovative spraying techniques (Svendsen, 1980, p. 15). Shortly after being appointed in the Bauhaus, Kandinsky supervised a workshop on wall-painting in the spring of 1922. Under Kandinsky’s direction “the most ambitious large-scale work of his career” was painted (Bergdoll and Dickerman, 2009, p. 122). In this work paint-spraying techniques were extensively employed. Later on, Kandinsky frequently employed such techniques in his own works. Kandinsky’s *Horizontal Blue* (1929) is an example of his spray paintings. In *Horizontal Blue*, “the paper was washed with pale green watercolor, then sprayed with successive layers of green, two shades of blue, and rose. The horizontal element, red square and blue-green rectangle were added last. Fine particles of sprayed watercolor cover the entire sheet.” (Svendsen, 1980, p. 15)

In April 1933, the German Bauhaus was permanently closed. However, a number of its teachers and students managed to emigrate to the United States. In 1937 Moholy-Nagy established the New Bauhaus in Chicago, ironically the place where the airbrush was first manufactured.



Figure 22: Paul Klee, *View of a Landscape*, 1926. Airbrushed gouache on paper mounted on light cardboard, 29.8 x 46.3 cm. Philadelphia Museum of Art

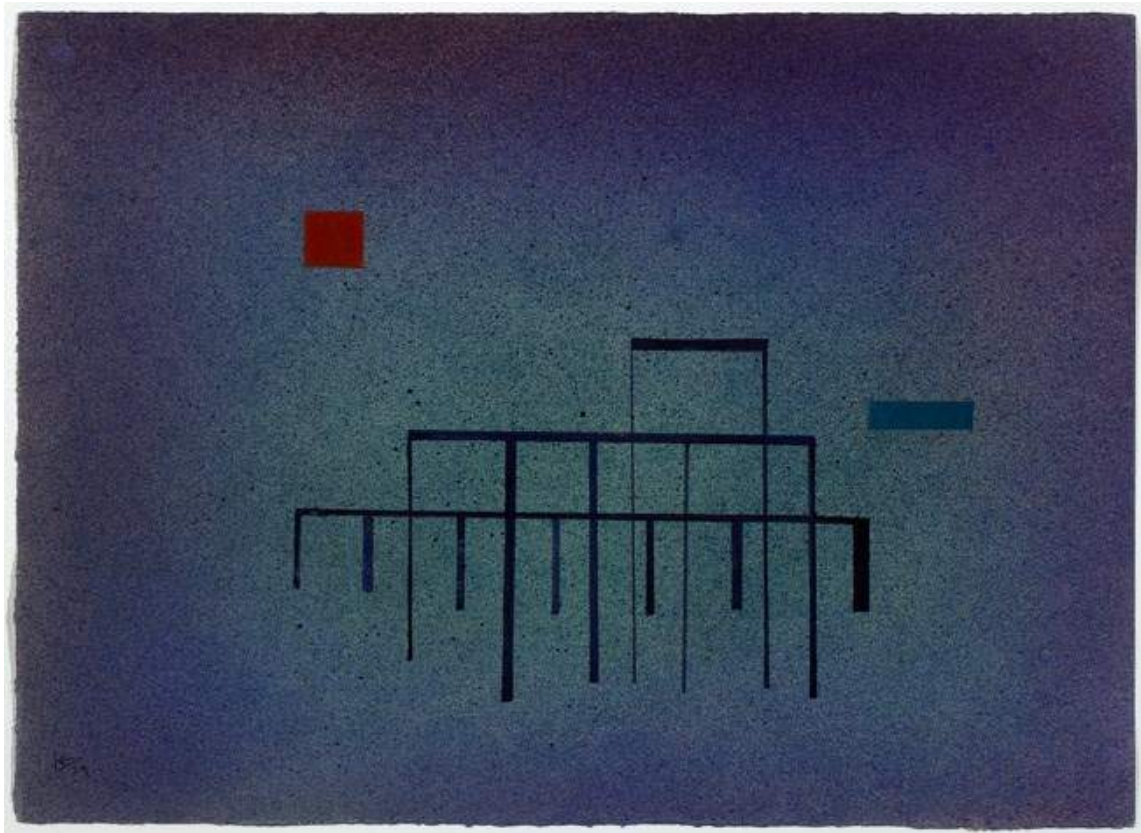

Figure 23: Wassily Kandinsky, *Horizontal Blue*, 1929. Airbrushed watercolour, gouache and blue ink on paper, 24.2 x 31.7 cm. The Hilla von Rebay Foundation

2.4.3 The 1930s

The world was hit by the Great Depression, the infamous severe economic depression originated in the United States in late 1929 and lasted for almost a decade. In December 1933, Roosevelt's administration launched the Public Works of Art Project (PWAP), a programme intended to support unemployed artists through a number of art projects. This large scale government-sponsored art initiative produced more than 400 murals and thousands of easel paintings and other art forms (Eldridge, 2008, p. 157). "This idea of public patronage for the arts derived largely from the success of public art in Mexico." (Selz and Landauer, 2006, p. 32) The Mexican artists "Diego Rivera, Jose Clemente Orozco and David Siqueiros did much to inspire the muralist movement in America." (Ludington, 2000, p. 231)

Among the most influential Mexican artists of the time was David Alfaro Siqueiros (1896-1974). This revolutionist Mexican artist, driven by his solid social-political stance, wanted to make stronger statement in his unconventional murals via exploiting new materials and techniques. Siqueiros was jailed in Mexico in 1930 for his political activities. Soon after, in 1932, he was exiled to the United States. He went to Los Angeles where he taught courses in fresco painting at Chouinard Art School. Siqueiros painted three murals in different locations during his short stay²¹ at Los Angeles, and he started at that time to experiment with new tools, including the airbrush. On this, Goldman (1974, p. 321) comments:

The three murals marked an important turning point in Siqueiros' development. They mark the release and outpouring of a large creative energy denied walls to paint on for almost 10 years. In this first encounter with the great industrial resources of the United States, his search for a new art style expressive of his revolutionary ideals was augmented by technical means to change the methodology of muralism itself—a methodology that had been fixed since the Renaissance. Important innovations of this period included the development of a dynamic pictorial surface for the moving spectator, and experimentation with cement and the airbrush for fresco application...

Stein (1994, p. 75) further explains Siqueiros' choice of materials: "Since the traditional fresco method of painting on wet lime plaster would not survive outdoors, Siqueiros proceeded to modify the "pure" method by substituting cement in place of lime, because of its more durable qualities outdoors. The cement would set faster, so a quicker application of color was needed. This led to the innovation, at least for Siqueiros, of the use of the spray gun in fine art."

²¹ Siqueiros stayed at Los Angeles in 1932 only from May to November. He was eventually forced to leave after his strong political elements in his murals were provoking enough for the society at that time.



Figure 24: Siqueiros giving a presentation of the use of spray gun on a mural painting (Ranee Silv, 2013)

2.4.4 Post–World War II

Interestingly, throughout the first three decades of the Twentieth Century, spray painting techniques were employed only by some of the boldest and most unorthodox fine artists. The deteriorating situation in Europe during the years of World War II forced many leading European artists, among others, to resettle in the United States. New York superseded Paris as being the focal point of avant-garde art movements (Kemp, 2000, p. 417). Mainstream artistic movements of the time included Abstract Expressionism (with its two major subdivisions; Action Painting and Color-Field Painting), Minimalism, Pop Art and Photorealism.

The airbrush became perfectly situated along with the other tools of even more artists. That was possibly due to various factors. One important factor is the rise of the avant-gardism which was advancing and pushing boundaries through those various artistic movements emerging at the time. Cottington (2013, p. 4) describes avant-garde as an “art practice (in its broadest sense) that sought to say something new in its time, to acknowledge the implications and potential of new (including popular, mass) media, to stake a claim for aesthetic autonomy, or to challenge prevailing values.” According to these notions, avant-garde artists were readily willing to explore new materials and techniques, including spray painting. A consequent factor is that avant-garde artistic movements – Pop Art is a prominent example – helped blur the distinction in traditional Western aesthetics between fine art and commercial art. The airbrush, which has long been considered a commercial art tool, was becoming adopted in fine art painting. Several artists produced their paintings over large canvases. Some found spraying a practical way to cover their huge spaces with paint. Photorealists, for example,

“borrowed from Pop Art the adoption of methods derived from commercial art (such as airbrushing and the use of opaque projectors to enlarge images), which were essential in achieving the photographic look.” (Molinard, 2005, p. 5) The introduction of modern paints, particularly acrylic paints, also eased to a greater extent the exploitation of the airbrush in fine art painting.

These reasons are likely to have played a key role in motivating more than a few artists from different Post-WWII artistic movements to actively use the airbrushes and spray guns. Examples of Color-Field artists are; Jules Olitski and Dan Christensen, Pop Art; James Rosenquist and Peter Philips, Photorealism; Chuck Close and Don Eddy. Due to the importance of the modern paints for airbrush paintings, further discussion on those artists and others is given in chapter 3.

2.5 Conclusion

The present chapter has investigated the status of the airbrush in the context of fine art. This chapter has explored the important role of Liberty Walkup, besides being the first producer of the airbrush, in the establishment of the Illinois Art School. The latter has been the first ever institute that has formally taught the use of the airbrush. Illinois Art School has certainly helped a considerable number of its graduates at the time to gain experience with the airbrush. Among those graduates the American painter Wilson Irvine is a notable example.

That has consequently had its impact on the future of the relationship between the airbrush and fine art painting that has not been yet established in the late 19th Century and the early years of the 20th Century. However, as this chapter has also demonstrated, the airbrush in those early years has had its main influence on other artistic fields, notably illustration and commercial art. The prominent Pin-ups illustrators, George Petty and Alberto Vargas famously relied on the airbrush to create their illustrations.

There were a few known experimentalists who started to emerge in the early years of the Twentieth Century, notably the Dadaist Man Ray who experimented with the airbrush up to 1919. The 1920s witnessed further rethinking in terms of the ideas, materials and techniques of fine art. The establishment of the German Bauhaus in 1919 have massively contributed to the 20th Century, challenging the conservative view towards unconventional methods and tools in fine art, including – of course – the airbrush. In the 1930s the Social Realist Siqueiros started to experiment with spraying techniques.

This chapter went on to explore the post-World War era with an increasing number of artists who have become more encouraged to experiment with new tools and techniques. Artists of different art

movements made use of the airbrush in their paintings, such as the Colour Field artist Jules Olitski, the Pop artist Peter Phillips and the Photorealist Chuck Close.

The next chapter is meant to overview the history of modern paints, particularly acrylics which have hugely facilitated the incorporation of the airbrush by many artists for paintings. Reasons of such an impact will be discussed.



Figure 25: cartoon by Bowers, published in *Boston Daily Globe*, 21 May 1922 (ProQuest Historical Newspapers: Boston Globe 1872 – 1979, pg. C4)

Chapter 3: An Overview of Modern Paints and its Impact on the Use of the Airbrush in Fine Art Painting

3.1 Introduction

For thousands of years, paint has been always consisted of two main components; pigment (the colorant) and medium (the binding substance). Both pigments and binding media, besides any other additives, have always been obtained or extracted from natural sources, either organic or inorganic. Various types of substances derived from a myriad of organic natural materials have been used as pigment binders throughout many centuries, including certain types of oils, egg yolk, gums, waxes, etc. Oil paints are known to painters in Northern Europe at least from the 13th Century (Mills and White, 2012, p. 36). Oils, in particular, gained wide popularity and dominated the painting art in Europe. A transitional period has of course preceded that rise in popularity of oil-based paints. The previously dominating egg tempera that highlighted an era of old Western masters from late Medieval to early Renaissance has been gradually mixed, and then completely replaced, with oil since the 13th Century in many paintings. In Italy, for example, Botticelli (1445-1510) used the method of *tempera grassa*, in which a drying oil is blended with egg yolk (Ward, 2008, p. 669). Giovanni Bellini (1430-1516) used pure egg tempera for his early works before he started to use oil-tempera techniques, after which he painted almost exclusively with oil (Mayer and Sheehan, 1991, p. 257). Cosimo Tura (1430-1495) painted his '*Allegorical Figure*' with egg tempera, then at a later point he repainted it using walnut oil (Dunkerton, Roy and Smith, 1987, p. 30).

Oil paints are traditionally made using 'drying' vegetable oils, such as linseed, poppy and walnut oils. It is now well established that 'drying', in this context, means a curing of the oil-based paint film which results from a series of chemical reactions which occur in the presence of Oxygen. The constituent, unsaturated fatty acids of the oil polymerise, and turn the paint layer into solid film which is insoluble in water.

For hundreds of years painters appreciated the slow curing characteristic of the drying oils, albeit not quite happy with certain aspects of deterioration which occur to oil-based paint films, particularly their infamous yellowing. Yellowing, among other visually negative changes occur to ageing oil-based paint films, have been always a concern to painters, colourmen and even others involved like art dealers and collectors. Everyone has seen how the white in painted eyes turns into brownish ochre, and the bright blue in the skies shifts to greenish in colour.

Accordingly, there are methods that were long ago developed to refine drying oils, notably linseed oil, in order to minimise or delay its yellowing effects in paintings. Linseed oil is extracted from ripened flaxseeds either by hot-pressing or cold pressing. Cold-pressed linseed oil is superior to hot-pressed linseed oil in terms of the preparation of artist-grade oil paints. Hot-pressed linseed oil required further refinements to be suitable as a paint medium. Refinements could be performed mechanically and chemically. Traditionally, raw linseed oil has typically been used, and it has been made by letting crude oil stand in tanks for some time and wait for impurities to settle down (Mayer and Sheehan, 1991, p. 171). In spite of such efforts, the yellowing of oil paints persisted along with other problems like embrittlement and cracks in oil-based paint films.

The 20th Century came with an art world that has already been revolutionised against traditional forms and ideas. The introduction of daguerreotype and the birth of photography by the mid-19th ignited strong reactions among painters. Some of them thought fine art has been about to decline after such an invention which supersedes even the most skilful realistic painters. It is frequently said that when the French painter Paul Delaroche (1797-1856) saw Daguerre's invention he proclaimed: "from today, painting is dead" (Bann, 1997, p. 226). On the other hand, there was a rapidly escalating desire by the painters to counter such claims and prove that fine art painting is, and will forever be, alive even in different forms and through new ideas. The French Impressionists have made the doors wide open to a subsequent crescendo of art movements bursting with new perspectives for all aspects of fine art, and consequently motivated artists to actively look for new techniques and materials to correspond to their own ideas and forms which they wanted to create.

The 20th Century came with an introduction of a vast array of synthetic polymers from which several compounds have been manufactured into paints and coatings. Many artists have been eager to venture new boundaries with the help of those new materials, from the use of alkyd-based Ripolin by Picasso, through to the use of nitrocellulose-based Duco by Siqueiros, up to acrylic resin-based Magna and Aquatec by Morris Louis.

This chapter is an overview of those revolutionising paints' media. The paints' media that have had a huge impact on the art world, and without which the airbrush would likely not have been used in fine art painting, at least to the extent that today exists.

3.2 Modern Paints: The Era of Synthetic Paint Media

Modern paints, According to Learner (2005, p. 244), can be "divided into two groups according to their primary end user: (1) those paints manufactured specifically for artists' use ('artists' paint'); and (2) those more commercial paints made for household decoration ('housepaint')." As summarised in Table 1, and as will be discussed in the next section of this chapter, the production of house paints

preceded artists' paints. Fine artists had to use the commercially available paints mainly dedicated for industrial and decoration purposes for about forty years, until their needs were finally noticed by colourmen and paint manufacturers by the mid-Twentieth Century.

Table 1: Dates of introduction of principal binders in modern paints (T Learner, 2007, p. 4).

Paint Type	Date of Introduction
Oil artists' paint	Antiquity
Nitrocellulose house paint	Late 1920s
Alkyd house paint	Late 1930s
PVA emulsion house paint	Late 1940s
Acrylic solution artists' paint	Late 1940s
Acrylic emulsion artists' paint	Mid-1950s

3.2.1 In the Beginning were the House Paints

It is not difficult to track when a synthetic organic medium or pigment was first introduced to the market, but it is not as straightforward to track when the same product was first used for a painting (Russell, 2010, p. 122). It is at least known that prior to the time of acrylic paints dedicated specifically for fine artists, there was an effective use by artists of commercially available house paints and industrial coatings. Those products were already commercialised and became a norm in the market years before the introduction of artists' acrylic paints. That gap in time between the introduction of commercial synthetic coatings and the production of dedicated synthetic artists' paints is pragmatically explained by Gettings (1971, p. 8) who says: "The artist is, and always has been, too unimportant an economic unit in society to have a massive industry working at his behest, so the exciting new range of polymers and copolymers which are now available to him have been developed mainly for other purposes than the production of pretty pictures intended to grace the walls of homes and galleries." So, until manufacturers recognised the needs of the 20th Century artists and realised

that the already available synthetic media could be refined towards making artists-dedicated paints, artists obviously used whatever was available from the new media.

Reportedly, Picasso was among the very first artists who have used the readily available house paints (Standeven, 2011, p. 4), and he made use of them throughout his entire artistic life from the cubic period until he died in 1973 (Tom Learner, 2005, p. 249). During his early experimentations with house paints he began, in 1912, to use the commercially available Ripolin. The same product was also exploited shortly after by other well-known artists like Francis Picabia and Joan Miró, and it was used extensively by Sidney Nolan from the mid-1940s (Standeven, 2011, p. 4).

British artist Francis Bacon (1909-1992) was another well-known painter who extensively used commercial house paint in his artworks. According to Russell (2012, p. 200), Bacon's studio was found to have contained "many tins of household paint... mainly Carsons and Dulux brands with a small number from other manufacturers."

House paints in general, throughout the 20th Century, depended on manufacturing three main classes of binding media; they are alkyds, polyvinyl acetates (PVAc emulsions) and Nitrocellulose (Tom Learner, 2005, pp. 249–251). According to Learner (Learner, 1998, p. 8) Alkyd paints are comprised of three components: "a polyhydric alcohol (usually glycerol or pentaerythritol), a polybasic acid (normally phthalic anhydride) and an unsaturated mono acid (normally added in the form of a drying oil)." PVAc (not to be confused with polyvinyl alcohol 'PVA') is a rubbery thermoplastic polymer that have wide uses in adhesives and house paints. PVAc paints first appeared around the same time as acrylic paints in the 1940s and they were temporarily marketed for artists and hobbyists but then shortly mostly discontinued. Nitrocellulose was the earliest constituent for manufacturing industrial coatings and house paints. However even for industrial purposes, nitrocellulose have now "largely been replaced by thermosetting acrylic coatings in the automotive industry" (Association, 1993, p. 245). Early nitrocellulose paints such as Duco was exploited in fine art by Siqueiros as will be presented further; shortly in this chapter.

3.2.2 The Introduction of Artists Acrylic Paints

They were the early years of the Great Depression when Leonard Bocour (1910-1993) started his business 'Bocour Hand-Ground Colors' in New York in 1932. "There was no other job," Bocour recalls, "so we did it, and I went peddling the paint from studio to studio" (Leonard Bocour, 1978). Bocour's business started in a rented room and then steadily grew until the late 1940's, when he introduced to the art world his Magna paints. Bocour Magna was indeed a landmark in the history of art materials, in spite of the short-lived brand. Thanks to a booming in science and industry, Magna

was a very important introduction to the era of synthetic paints that revolutionised that art world in the Twentieth Century.

We should, however, go back in time a few decades before the Magna era to track earlier discoveries of synthetic media. From the mid-19th Century, chemists were already on track, producing synthetic polymers. In 1843, the Austrian chemist Josef Redtenbacher (1810-1870) reported a discovery of a new acid that he synthesised through the oxidation of acrolein with air, and he named it ‘acrylic acid’ (Neher, 1936, p. 267). Acrylic acid is a chemically organic compound in the form of corrosive, colourless liquid. It is the root from which an enormous number of derivatives are synthesised and employed for countless applications and uses. In 1880, “the polymerisation reaction of both methacrylates and methyl acrylates” was first reported by the Swiss chemist Georg W.A. Kahlbaum (Kricheldorf, Nuyken and Swift, 2004, p. 241). By 1900, most of the common acrylates were already known (Standeven, 2011, p. 106). However, acrylic polymers began to be systematically studied for technical use in the early 20th Century. In 1901, the German chemist Otto Röhm submitted his doctoral thesis to University of Tübingen titled: ‘Polymerisation products of the acrylic acid’, for which he took out a first patent in 1912 (Aftalion, 1991, p. 149). In 1907, Otto Röhm joined forces with Otto Haas and founded the Röhm and Haas Company in Germany, which specialised in chemical industry. Otto Haas then founded a subsidiary of Röhm and Haas in the USA in 1909. In 1913, the American subsidiary “began producing acrylates and their polymers... and new applications were found for these new materials in paints...” (Aftalion, 1991, p. 151). Table 2 shows the trade names of the raw materials of acrylic resin products for water-based paints by Röhm & Haas. A few years later, after the World War I, Leonard Bocour started to deal with the Röhm and Haas Company to get his supplies of acrylic resins, by which he was making his new paints, Magna.

Table 2: trade named raw materials of acrylic resin products for water-based paints by Röhm & Haas (Flick, 1994, p. 458)

RAW MATERIAL	CHEMICAL DESCRIPTION	SOURCE
AC-1024	Acrylic emulsion	Röhm & Haas
Acryloid WR-97	Acrylic resin	Röhm & Haas
Acrysol ASE-60	Water-soluble acrylic resin	Röhm & Haas

Acrysol I-62	Water-soluble acrylic resin	Röhm & Haas
Acrysol I-98	Water-soluble acrylic resin	Röhm & Haas
Acrysol QR708	Water-soluble acrylic resin	Röhm & Haas
Acrysol RM-5	Water-soluble acrylic resin	Röhm & Haas
Acrysol RM-825	Water-soluble acrylic resin	Röhm & Haas
Acrysol RM-1020	Water-soluble acrylic resin	Röhm & Haas
Acrysol SCT-275	Water-soluble acrylic resin	Röhm & Haas
Acrysol TT-615	Water-soluble acrylic resin	Röhm & Haas
Acrysol TT-935	Water-soluble acrylic resin	Röhm & Haas
Acrysol WS-68	Water-soluble acrylic resin	Röhm & Haas

“Well, it was started because I had a curiosity about it. And I'll tell you the beginning of it.” This is how Leonard Bocour started on a summer day of the year 1978 to tell his interviewer his story with Magna paints. At that point he was a 68 year old man who was having a reminiscent talk about a series of events that he ventured as a young man. “It started about November 1941, some guy walked into the shop... with something like white syrup. I said, "What's that?" He said, "It's an acrylic." Frankly, I'd never heard the term” he recalls. As a coulorman, Bocour was interested to test that new material for making paints. He first performed mixtures of acrylic resin and white pigment. He wanted to see if acrylic would cause yellowness to white. “What really got me was how white it was,” Bocour tells his interviewer (Leonard Bocour, 1978).

There were a good variety of colours readily provided in paint tubes and jars by Bocour (Figure 26). The Magna product line was based on solvent-soluble acrylics. They could be thinned using turpentine and mineral spirits. However, waterborne acrylic emulsion paints, which were marketed only a few years later, culminated in the introduction of Magna paints. Two trade names entered to the

market almost simultaneously by two different companies; those trade names are Aquatec and Liquitex. Aquatec was introduced by Leonard Bocour and his nephew Sam Golden (later in 1980 the founder of Golden[®] Artist Colors, Inc.), and Liquitex was introduced in 1954 by Henry Levison a chemist and paint maker (Jablonski *et al.*, no date, p. 2). Other trade names of similar products entered to the market around that time; such as Cryla (introduced in 1963 by Rowney & co., England), Chromacryl (introduced in 1964 by Chroma Australia Pty. Ltd., Australia) and Hyplar (introduced in 1966 by M. Grumbacher, Inc., USA).



Figure 26: a mid-20th Century colour chart of Magna paints by Bocour (morrislouis.org)

3.3 Acrylic paints

As previously noted, any type of paint is a combination of two main ingredients: a colourant known as a pigment which is usually used in a solid form, and a substance known as ‘medium’, and which is used in a liquid form. What gives the latter the liquid form is its solvent that is also known as a vehicle because it acts as a carrier to which the pigment particles are mixed or dispersed. The medium

must possess adhesion properties in order to hold pigments in place, especially after curing to paint films. It also must turn into a solid paint film without retaining prolonged viscosity (surface tack).

From a fine artist's perspective, acrylic emulsion paints proved to have been particularly versatile for the various ways in which they can be employed. Being now widely used in the water-based form, acrylic emulsion paint is even further advantageous for artists who prefer not to use toxic or odoriferous solvents as in the case with oil paints. The workability of acrylic paints is another important advantage. They can be thinned to apply washings or to be used for spraying purposes. They can also be used in fairly thick applications to obtain high brush or palette knife strokes. Acrylic emulsion paints can also be mixed with a variety of other materials in order to achieve certain effects. These materials can be used to increase or decrease the gloss of acrylic paints; they can be used to increase or decrease consistency and they can even be used to induce craquelure.

Acrylic paints in general are either solvent-based or water-based. The latter type is now more common for painting, while the former can be found in early products, e.g. Bocour Magna. Both types, however, are not water-soluble after curing²².

According to Learner and Ormsby (2012, p. 566), acrylic emulsion paints are “highly complex paint formulations.” Learner (1998, p. 9) also provides an informative description of the chemical nature of acrylic paints' media:

Acrylics are high molecular weight (HMW) polymers of the esters of acrylic and methacrylic acids. They are available either as dispersions or in solution, but the dispersion (or emulsion) form is by far the most important... The early acrylic emulsions were mostly based on a copolymer of ethyl acrylate (EA) and methyl methacrylate (MMA). More recently, however, these emulsions have largely been replaced by copolymers of n-butyl acrylate / methyl methacrylate (nBA/MMA). Sometimes styrene is used instead of MMA in the copolymer (i.e. a styrenated acrylic) which will reduce the cost of a formulation, but will render the film more prone to yellowing. The solution form of acrylic paints have all been based on poly n-butyl methacrylate (pnBMA).

²² “Magna® dried quickly by evaporation of organic solvent, remained resolvable in many hydrocarbon solvents as well as further layers of paint and could be blended with oil paint. In contrast, the drying process of emulsion paints involves a complicated coalescence of emulsified polymer spheres after an initial evaporation of water; these paints become insoluble in water - and further layers of emulsion paint - after they have dried.” (Jablonski *et al.*, no date, p. 2)

3.4 Synthetic Paints in the Artistic Context

Commenting on an interview question regarding his controversial method of painting, Jackson Pollock (1912-1956) contended that “new needs need new techniques,” and he then elaborated: “modern artists have found new ways and new means of making their statements. It seems to me that the modern painter cannot express this age, the airplane, the atom bomb, the radio, in the old forms of the Renaissance or of any other past culture. Each age finds its own technique” (Karmel, 1999, p. 20)

One can confidently argue that this commentary by Pollock is valid. The Acrylic emulsion paint, for example, is the most important art material introduced in the 20th Century to the art world. However, it would not have been effectively used in fine art without the existence of those “new needs” Pollock indicated. Mayer (1991, p. 257) also expresses a similar opinion as he believes “no movements or schools of art began as a result of the discovery of new materials or inventions of new techniques.” He then further explains: “Rather, when new ideas and aesthetics departures arose they created a demand for new technical methods that could express them in a more appropriate and fluent manner than was possible with the older methods.” In another interesting opinion given by Elkins (2004, p. 119), he believes that “acrylics could only be successful in the Twentieth Century, when painters are more likely to be impatient,” he then goes on, saying that “in past centuries, acrylic would have seemed to dry far too quickly.” Mayer’s thoughts remind us with what was mentioned in chapter two about Man Ray, when he simply said: “I wanted to find something new.” In fact many fine artists of the Twentieth Century sought after new methods, techniques and materials to express their artistic visions. It was, accordingly, in the astute colourmen’s hands to supply those artists with whatever can be used to satisfy their artistic desires. Leonard Bocour described that when he was recalling the times when his new paint product became a hit, as he simply said: “We really were filling a need.”

Among the first well-known painters who have used Magna Paints, Leonard Bocour particularly mentions Morris Louis (1912-1962), Kenneth Noland (1924-2010), Jules Olitsky (1922-2007) and Helen Frankentahler (1928-2011) (Leonard Bocour, 1978). Those all were American Abstract Expressionist artists who pioneered the art movement known as Colour-Field Painting, and which emerged in the USA in the 1940s. Morris Louis was, apparently, particularly interested in Bocour’s new material. On that Bocour recalls: “Morris Louis was one of my steady customers. The fellow you remember -- like he's the big hero. When I go around talking about acrylics, the only one that they really ask me about is Morris Louis” (Leonard Bocour, 1978).

3.5 Synthetic Paints and the Airbrush Painting

With little doubt, it could be said that airbrushing would not have been seriously employed in fine art painting without the introduction of synthetic paints. Prior to that, the main paint materials used for

airbrushing were watercolours, gouache and inks. Those paint materials are best suited for paper supports and not for canvases or panels, the supports commonly used by painters. The painters therefore, in the early years of the Twentieth Century, were ostensibly not yet ready to use the airbrush, since oil paints are generally not considered suitable for spraying. Obviously, even Man Ray for example, with all his passion with airbrushing, mainly used the airbrush to paint on paper with water colours and the likes during the second decade of the 20th Century when synthetic paints were not yet quite perceived for artistic uses. However very shortly, in the 1920s, artists started to effectively look for the possibility of using those paints for their artworks. Indeed, as have been mentioned earlier in this chapter, several artists at that time were bold enough to exploit those new commercial media, and some of them were even bolder to exploit them using spraying techniques.

An eminent example at that time is Siqueiros. Siqueiros' airbrushes and spray-guns were fed with other commercial paint materials unconventional in fine art, such as Duco paint (Winegrad, 2001, p. 38), the nitrocellulose-based low-viscosity spraying lacquer introduced in 1923 by the American company Du Pont (Standeven, 2007, p. 76), that was intended for the finish of automobiles, hardware and appliances.

Siqueiros' passion and enthusiasm led him to organise more than one of several experimental workshops under the title 'A Laboratory of Modern Techniques in Art' "where modern techniques and media could be utilized for the purpose of making art" (Baetjer, 1997, p. 66). Those workshops were conducted at Siqueiros' New York studio in 1936, where several modern fine artists gained new experiences, including; "Harold Lehman, Sande McCoy, Jackson Pollock and his brother Sande, Axel Horr, George Cox, Louis Ferstadt, Clara Mahl, Luis Arenal, Antonio Pujol, Conrado Vasquez, José Gutiérrez²³, and Roberto Berdecio" (Hurlburt, 1976, p. 238). While attending Siqueiros' workshops, Pollock "took special note of the pyroxylin paint as it dripped on the floor. In the random dripping, and the subsequent effects of the quick-setting pyroxylin²⁴ paint, lay Pollock's future style" (Stein,

²³ José Gutiérrez is of a special mention here. In 1934 he and Siqueiros cooperated with Union Carbide (now subsidiary of Dow Chemical Company) to develop a medium suitable for outdoor mural paintings, following a manifesto published by Siqueiros in which he criticised the inclusion of fine art in museums and proclaiming for an art that exists outdoors (Louis and Upright, 1985, p. 49). Gutiérrez participated in Siqueiros's workshop and witnessed the techniques and materials used by him and the other participated artists. Later, he published two books on the subject: '*From Fresco to Plastics: New Materials for Easel and Mural Paintings*' (Gutierrez, 1956) and '*Painting with acrylics*' (Gutiérrez and Roukes, 1965). In 1953, Gutiérrez founded his own company in Mexico City to produce water-based acrylic emulsion paints from which it is claimed that he supplied "most of the Mexican master muralists" ('History of Politec', no date). Gutiérrez's product was trademarked under the name 'Politec', less known in Western Europe and the USA. The product was lately reproduced with the same trademark.

²⁴ Pyroxylin was another nitrocellulose-based synthetic paint product introduced by Du Pont in 1904 (dupont.com)

1994, p. 98). Another note about what Jackson Pollock perceived from Siqueiros' workshops was given by his elder brother Charles, who wrote: "Some of the technical resources employed there [in the workshop] are of interest... The violation of accepted craft procedures, certain felicities of accidental effect (the consequences of using Duco and the spray-gun on vertical surfaces), and scale, must have stuck in [Jackson's] mind to be recalled later, even if unconsciously, in evolving his mature painting style" (Karmel, 1999, p. 186).

Among Color-Field painters, Jules Olitsky (1922-2007) started to use the airbrush onto his paintings in 1965 "in order to create dematerialised fields of colour" (Olitski, 1968). Upon exhibiting at the 1966 Venice Biennale, the renowned art critic Clement Greenberg (1909-1994) wrote in his catalogue essay: "The grainy surface Olitski creates with his way of spraying is a new kind of paint surface." (Stephanie Salomon, 2007, p. 112). Fried (1998, pp. 133-134) further describes Olitski's technique:

Olitski's spray technique could hardly be simpler. He lays a length of unprimed and unsized canvas on the floor and sprays into it acrylic paint of different colors from as many as three spray guns powered by an electric air compressor. (In his first spray paintings he began by drawing the canvas through a trough filled with paint, but after a while stopped preparing it in this way.) By the time he stops working, often with two spray guns simultaneously, the raw canvas itself is no longer visible, except in rare cases toward the edges. In some paintings the surface of the canvas consists of small flecks of different colors which, depending on the wetness of the surface at the moment they were sprayed on, are distinct or slightly blurred or almost dissolved into adjacent flecks, and depending on the size of the droplets in a given burst of spray, fluctuate in size from extremely fine points to larger though still minute splashes or beads of pigment. In other paintings the droplets seem to have flowed into one another completely and there are no flecks at all.

For his painting, entitled '*Instant Loveland*' (Figure 27), Olitski used a spray-gun with a variety of nozzles. The paints he used were of Aquatec brand, the acrylic emulsion paints produced by Leonard Bocour and Sam Golden. He worked on an unprimed canvas that was laid out on the floor, which then was stretched on the stretcher after the completion of the painting (Olitski, 1968).

Another Colour-Field painter who exploited with sprayed synthetic paints is Dan Christensen (1942-2007) (Figure 28). Christensen was among a new generation of the abstract expressionists who were enthusiastic about the new paint media, beginning in the 1960s. Christensen favoured the manipulation abilities of the acrylic paints, compared to oil paints, as he was able to thin them to the consistencies he desired without losing the tense of the colours. Furthermore, he liked working with additives readily available and specially made to extend the qualities of the acrylics (Christensen and Peters, 2011, p. 3).

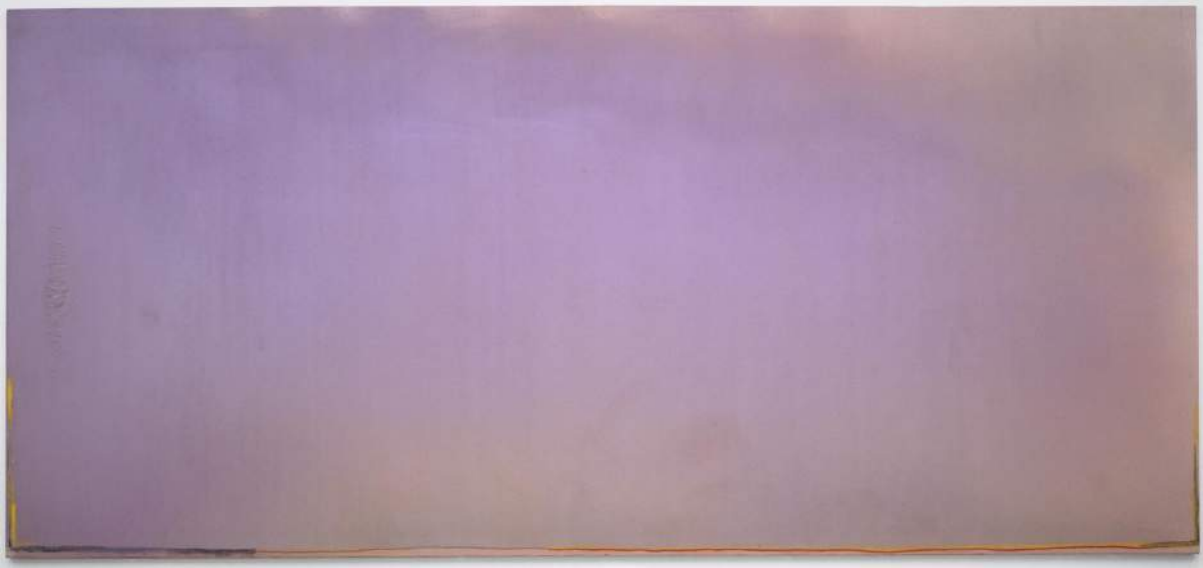

Figure 27: Jules Olitski, *Instant Loveland* (1968), 2946 x 6457 mm, airbrushed acrylic paints on canvas (courtesy of Tate)

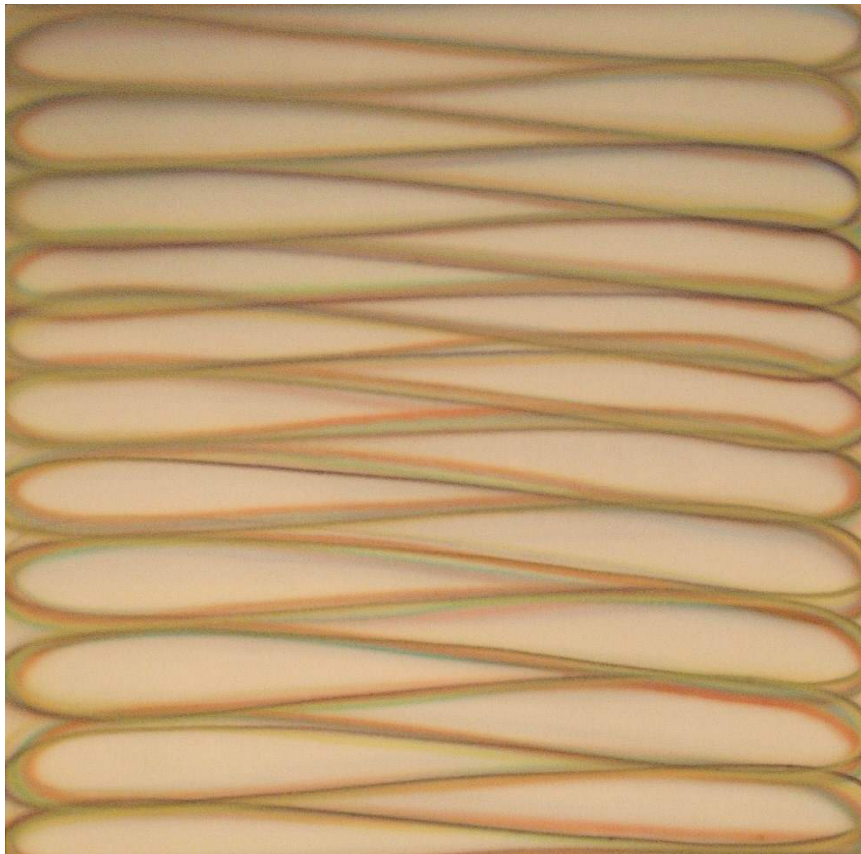

Figure 28: Dan Christensen, *Conjugate* (1967), airbrushed acrylic on canvas 48x48" (danchristensen.com)

The British Kinetic and Op-artist Peter Sedgely (b.1930) has also established a unique style in Op-art painting based on synthetic paints and airbrushing techniques (Figure 29). Sedgely, who began painting in 1963, was influenced by the Op-artist Bridget Riley (b.1931) (Chilvers and Glaves-Smith, 2009).

Barrie Cook (b.1929) is also a British artist who executed his paintings with a spray gun and acrylic paints. His painting shown in (Figure 30) belongs to a “series came about through several months of drawing, invariably using a spray gun and involving a number of formats and ideas,” Cook describes his technique in a letter sent to the Tate, “I worked from left to right, slowly building up to reach the triangle, which is black acrylic stain, moving through this and once more using Indian Red on the right-hand side of the painting. I then sprayed white paint from the triangular black area to develop further the illusion of these half tubes. It then became a process of further spraying each layer of paint, which came as much from the dictates of my belly as from my head. I can’t recall using a brush at all, although normally I would use 4” brushes to place any basic colours before over-spraying.” (*Barrie Cook, ‘Painting’ 1970, no date*)

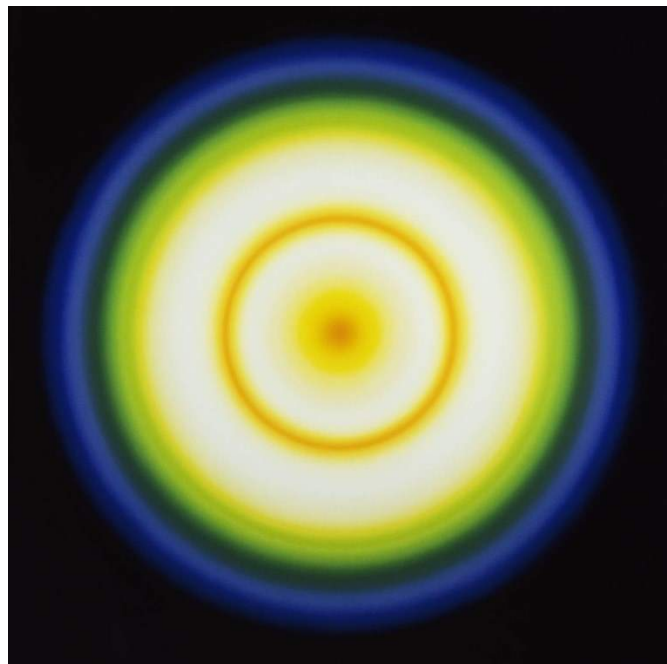

Figure 29: Peter Sedgely, *Colour Cycle III* (1970), airbrushed acrylic paint on canvas, 1841 x 1829 mm (Tate collection)



Figure 30: Barrie Cook, *Painting* (1970), airbrushed acrylic paint on canvas, 2440 x 3047 mm (Tate collection)

The combination of synthetic paints and spraying techniques later found even further welcoming hands in the Pop Art movement that emerged in post-war Britain and then shortly adopted in the USA in the 1950s. The American Pop artist, James Rosenquist (b.1933) used readily available enamel spray cans onto several paintings (Figure 31). He also made spraying attempts with the airbrush for printmaking (Moorhead, 1999, p. 58). Another Pop artist is the British painter Peter Phillips (b.1939) who was one of the youngest well-known Pop artists at that time. “During a two-year stay in New York (1962-64), Phillips bought an airbrush of the kind he had long considered” (Honnef, 2004, p. 19). Phillips applied airbrushing techniques and acrylic paints to several paintings from 1965 onwards (Figure 32).



Figure 31: James Rosenquist, *Marilyn Monroe, I* (1962), Oil and spray enamel on canvas, 236.2 x 183.3 cm



Figure 32: Peter Phillips, *Mosaikbild/Displacements* (1976), airbrushed acrylic on canvas, 220 x 230 cm, private collection (peterphillips.com)

The Photorealism art style that emerged in the 1960s in the US unquestionably boosted the use of the airbrush in fine art easel painting to limits that have not been pushed before. Influenced by the Pop art movement, several Photorealists, who extensively used the airbrush in their paintings, also used synthetic (notably acrylic) paints. Those Photorealists found the airbrush an essential tool in order to

achieve the photographic appearance they sought after in their paintings. What the Photorealists, in general, have had in common at that time is that they all relied on photographs as sources material for their artworks. The name Photorealism²⁵ – a contraction of photographic realism – came up later when it was ‘officially’ coined in the USA in a ‘manifesto’ declared in the year 1969 by Louis K. Meisel (1942-) an art dealer, author and the owner and director of Meisel Gallery in New York, specialised almost exclusively in Photorealist art. Furthermore, Meisel (Meisel and Seeman, 1989, p. 13) identified in the year 1972 a five-point conditions list that define a Photorealist, in his opinion:

1. The Photo-Realist uses the camera and photograph to gather information.
2. The Photo-Realist uses a mechanical or semi-mechanical means to transfer the information to the canvas.
3. The Photo-Realist must have the technical ability to make the finished work appear photographic.
4. The artist must have exhibited work as a Photo-Realist by 1972 to be considered one of the central Photo-Realists.
5. The artist must have devoted at least five years to the development and exhibition of Photo-Realist work.

Among the most notable Photo-realism pioneers who mostly, or even exclusively, utilised the airbrush in their Photorealist paintings; Chuck Close (1940 -) (Figure 33), Don Eddy (1944 -) (Figure 34), Audrey Flack (1931 -) (Figure 35) and Ben Schonzeit (1942 -) (Figure 36). Later in that period of time there were newer generation of Photo-realists who came onto the stage; including Cesar Santander (1947 -) (Figure 37) and Rudy Sparkuhl (1952 -) (Figure 38). That mid-generation of Photorealists was followed by a younger generation of fine artists who executed their paintings with the same art style, such as Juan Cossio (1960 -) (Figure 39), Hubert de Lartigue (1962 -) (Figure 40) and Simon Hennessey (1973 -) (Figure 41).

²⁵ Hyper-realism, Radical Realism and Super-realism are among alternative terms used generic to ‘Photorealism’, particularly in Europe.



Figure 33: Chuck Close with applying plaster to his wife, for an art project, and standing in front of his 21-foot-long *Big Nude* (1967), in the background his *Big Self-Portrait* (1967-68), (Close *et al.*, 1998, p. 205). Those paintings were the first Photorealist paintings by Chuck Close that he executed with airbrush.



Figure 34: Don Eddy, *Private Parking X*, acrylic on canvas, 66 x 95", private collection (Kuspit, 2002, p. 16)



Figure 35: Audrey Flack, *Marilyn*, (1977) oil over acrylic on canvas 20 x 20" (audreyflack.com)



Figure 36: Ben Schonzeit, *Bluish Plums*, 2010, acrylic on canvas, 33 x 33" (meisलगallery.com)



Figure 37: Cesar Santander uses an airbrush during working on one of his paintings (cesarsantander.com)



Figure 38: Rudy Sparkuhl, *Roots*, (2005) acrylic on canvas, 20 x 16" (sympatico.ca/gunther.sparkuhl)



Figure 39: Juan Cossio, *Impulso*, (2011) 185 x 75cm acrylic on canvas (juancossio.com)



Figure 40: Hubert de Lartigue, *W & W*, (2010) acrylic on canvas, 130 x 89cm (hubertdelartigue.com)



Figure 41: Simon Hennessey, *Westminster*, (2012) Acrylic inks on canvas, 61 X138 cm, (simonhennessey.com)

To achieve the ‘photographic look’ in their paintings, the Photo-realists, particularly those who mostly used airbrushing techniques, also deliberately prepared their canvases’ surfaces to an optimum smoothness, to the extent that made Meisel (1989, p. 15) believe that “if there were a way to bleach all color from a painting by Close, Flack, Schonzeit, Salt, or Eddy, we would be left with a perfectly smooth white canvas with no indication of what the image had been. If, on the other hand, one were to eliminate all color from a painting by Vermeer, Eakins, Harnett, Homer, Hopper, Cézanne, Dali or Wyeth, the image and shapes would still be visible, determined by paint thickness and brushstroke... Evenness of surface is one of the universal characteristics of Photo-Realist technique.” It is noticeable in this previous passage that Meisel specifically mentions some of the Photorealists who have worked the most with airbrush. In a recorded interview, Chuck Close (b.1940) confirms this information about the smooth finishing of his canvases: “When I got the white canvas I put fifteen coats of sanded of gesso.” (Diamonstein-Spielvogel, 1979) Close also mentioned his use of “an airbrush loaded with diluted acrylic” (Finch, 2012).

The Photorealistic paintings of Audrey Flack (b.1931) were often done with airbrushed acrylic paints with oil paints on top for details. Figure 42 shows Flack in the course of completing a commissioned portrait of the former Egyptian president Anwar El-Sadat (1918-1981), using airbrushed acrylic paints. Don Eddy’s (b.1944) painstaking technique, of applying small dots of acrylic paints with an airbrush, was developed from his early work in his father’s garage and through years of dedicated work in his photorealistic paintings solely with the airbrush.



الرئيس يتسلم الصورة التي اهداه له وفد رجال الاعمال الامريكانيين تقديرا لجهوده من اجل السلام

Figure 42: Right: Audrey Flack putting the finishing touches on a portrait of the Former Egyptian president Anwar El-Sadat with an airbrush, 1978. Left: “El-Sadat receives the portrait as a gift from a group of American businessmen for his efforts for peace,” according to the caption in Arabic. The picture is courtesy of Archives of American Art, Smithsonian Institution. The painting is courtesy of El-Sadat Museum, Egypt.

During the 1970s, the British artist John Salt (b. 1937) became among the known photorealist painters in the USA. Salt preferred depicting the scenes of wrecked abandoned cars. “In order to paint cars without romanticising the style, he used a spray painting method, along the lines of the actual technique used for painting cars” (Oxford, 2012, p. 322). After his return to Britain from the USA in 1978 he executed a painting entitled ‘*Ironmongers*’ with airbrushed “sign-writers’ paint,” according to the National Galleries of Scotland the current owner of the painting (Figure 43). Another painting by Salt is also an example of his style of using airbrushed acrylic paints to depict his preferred scenes of abandoned cars. The painting is currently owned by Birmingham Museums (Figure 44).

Simon Hennessey (b.1973) belongs to the latest generation of the Photorealists (Figure 45). He says about his technique: “I work with acrylic paints and inks, building up translucent layers as I go using either an airbrush or a paint brush... I tend to use paint brushes for the details and the airbrush and stencils to lay down quick color and tonal ranges. It also works when I’m aiming for a seamless blend in my paintwork. It’s a slow, sometimes tedious process, but it’s my favoured working method.” (Simon Hennessey, 2015)



Figure 43: John Salt, *Ironmongers* (1981), sign-writers' paint on canvas, 106.80 x 161.30 cm (courtesy of National Galleries of Scotland)



Figure 44: John Salt, Untitled (1975), 115 x 170.9 cm. ©John Salt ©Birmingham Museums Trust



Figure 45: Simon Hennessey working on one of his paintings (courtesy of Simon Hennessey)

It looks that the 80-years-old artistic partnership between spraying techniques and synthetic paints, started around the time of Siqueiros' experimentations, is highly unlikely to cease to exist anytime soon. Photorealism still attracts new generations of artists who want to achieve, and even compete with, the pioneering Photorealists. A number of them have already adopted the airbrush as their main tool to convey their skills. Moreover, other fine artists of different backgrounds and art styles are similarly interested in both the technique and the material. From 10th to 23rd July 2014 a New York Gallery called 'The Hole' held a group show at which 19 artists exhibited their paintings (Figure 46).

The show's title was *'Go with the Flow'* that was "looking at the diverse and contemporary uses of sprayed paint. From aerosol to airbrush and further into the field of atomized paint" (The Hole NYC, 2014). Parts of the text written for the open invitation to the show are noteworthy:

"...the 70s and 80s birthed graffiti culture, the single most impactful global image movement, and the world's cities have been covered in spray ever since. Besides the often-embarrassing graffiti art in galleries, this aesthetic mostly influenced painting from afar... But the commercial and the graffiti are not the only two angles from which to approach sprayed paint and this exhibition looks at the diversity of uses it has for contemporary artists now."



Figure 46: Part of the group show *'Go with the Flow'*, July 2014 (theholenyc.com)

3.6 Conclusion

The introduction of modern paints to the art world was by all means revolutionary. Modern paints, particularly acrylic emulsion paints, were the right companion to the airbrush and hence they facilitated its exploitation by fine artists. That was evident, for example, with Siqueiros who would not be able to accelerate the process of painting his murals unless he abandoned the conventional fresco technique and relied on modern paints, notably nitrocellulose paints, and spraying techniques. It was even more evident in many of the post-WWII artistic movements with their avant-garde artists who depended heavily on modern paints and accordingly developed unconventional techniques. The

artists became able to pour, splatter and spray their paints on their canvases without having to rely only on traditional tools like brushes or palette knives.

Acrylic paints were of special interest to artists since they were produced under the brand name Magna by the American Bocour Artist Colors, Inc. in the late 1940s. Acrylic paints became even more appealing when it was produced as emulsion rather than solution. It was finally possible to use water to dilute acrylic paints, more advantageous of course for airbrushing. Acrylic paints and airbrush became an indispensable combination for numerous artists of various artistic movements, such as Color-Field Painting, Pop Art and Photorealism. The present chapter provided several examples of prominent artists in this context.

Since the main question of this research is about the applicability of conventional image reintegration treatments for airbrush easel paintings, the next chapter is dedicated for an overview on the subject of the image reintegration.

CHAPTER 4 - An overview of image reintegration treatments for paintings conservation

4.1 Introduction

One can make an educated remark that the aesthetic conservation treatments, which can be collectively called ‘image reintegration’, have been among, if not the most, controversial aspects of art conservation. Moreover, they are likely to remain controversial in the future. This chapter offers an overview to this controversial type of conservation treatments. Image reintegration is an area full of nuances regarding the ethics of practice, as such it generates very strong opinions since it appears to distinguish between those working in an appropriate manner and those who do not. This, however, does not make it more important than other procedures, but it is certainly more visible and therefore more open to discussion and even controversy. The nature of the paint surface on airbrush paintings requires an overview to current practices in terms of image reintegration. This is to determine the appropriateness of those practices in the case of airbrush paintings.

Arguably, one of the issues that emerges when discussing this type of conservation treatments is the existence of numerous terms that are yet conterminous. Therefore, a definition of the collective term ‘image reintegration’, along with other related nomenclature, are introduced and discussed in this chapter. That is followed by an overview of the history of this type of conservation treatment, particularly in the context of the conservation of easel paintings. Approaches to image reintegration are then reviewed, with an emphasis on the unconventional approaches. Finally, issues of the ethics and aesthetics pertaining to image reintegration are discussed.

4.2 Terminology

Several 19th Century writings on the subject of restoration of fine art, that were particularly written in English and French, show that the term ‘restoration’ was used as an appellation to what is now known as image reintegration: “for example; a statement by Amand-Denis Vergnaud (1831, p. 1831) clearly shows that he distinguished between certain stages of conservation treatment: “Once the enlevage ‘removal of the original canvas’ and the relining have been completed, we proceed to the cleaning and the restoration”. Mogford (1845, pp. 59–64) had also talked about restoration within the meaning of filling and retouching in his book” (Soltan, 2010, p. 200). Later, however, Ruhemann (1968, p. 60) considers ‘restoration’ to cover probably all aspects of paintings conservation and even preventive conservation, as he says: “the word *Restoration* might conveniently be said to comprise five different measures: 1. *Preservation* of sound paintings, 2. *Treatment* of ailing paintings, 3. *Cleaning*, 4.

Retouching, 5. Re-varnishing.” Nevertheless, that use of this term by Ruhemann is, obviously, semantically inaccurate. Much more recently, for example, Burra Charter²⁶ clearly states in its “Article 1: Definitions” that restoration is part of repair which is to be distinguished from maintenance.

‘Image reintegration’, in the researcher’s opinion, is a successful collective term. It combines all known procedures employed in this type of art conservation which deals, as the term suggests, with the aesthetical aspect in an art work. It is a term that even combines any procedure that is yet to be widely employed in this field, even if that procedure is non-interventive²⁷. This claim is to be further investigated later in this chapter.

The term ‘Image Reintegration’, according to Poulsson (2008, p. 5), “has recently come into use in the UK”. The author does not yet mention how ‘recent’ this term is. Moreover, she believes that this term is used interchangeably with other terms like ‘retouching’ (Poulsson, 2008, p. 4). It is probably important to point out that Poulsson put this information in the context of the subject of the retouching of art on paper. Nevertheless, the term ‘image reintegration’ obviously covers other specialities of restoration of works of art, including of course, easel paintings which are the main subject of this research.

Ana Bailão, a researcher who is particularly interested in the subject of image reintegration, believes in a more recent paper that “the term used depends on geographic location. Therefore, it should be interpreted according to the historical evolution of the restoration of each country,” (Bailão, 2010, p. 127). Bailão also believes that the term ‘Retouching’ is “the most common term” used in England, Germany and Austria, the term ‘Inpainting’ in the US and Canada and finally the term ‘Reintegration’ in Spain, Italy and Portugal. On the other hand, Poulsson (2008, p. 4) says that “retouching is part of the process commonly known as reintegration in the UK and loss compensation in the USA.”

Poulsson (2008, p. 4) provides a useful account of the terminology related to that procedure of art restoration for which the researcher intentionally chooses, hereinafter, the term; ‘image reintegration’. The rationale behind this particular choice shall be discussed presently in this chapter. Poulsson presents terms frequently used in literature on art conservation and restoration: Loss Compensation, Image Reintegration, Inpainting, Retouching and Toning. She also transiently mentions other terms

²⁶ Burra Charter is a set of principles that have been first adopted in 1979 at Burra, Australia. The purpose of that charter is to create standards for heritage conservation practice in Australia. The current version of the Burra Charter was adopted in 2013.

²⁷ Further details with regard to recent non-interventive applications for image reintegration are to be presented, see “Non-interventive Retouching” section in this chapter.

that are comparatively uncommon or even unknown particularly to English literatures, e.g.: Intoning, Integration of Colours, Colour Compensation. Poulsson derives definitions for most of those terms mainly from Ruhemann's well-known book: *The Cleaning of Paintings*.

In an earlier remark, Ruhemann (1968, p. 241) mentions Loss Compensation as the American term alternative to "imitative or 'deceptive' retouching" with which "the matching of the texture is of importance." He then mentions 'Inpainting' as the American term alternative to 'Retouching' to point out to one of the most essential rules of ethical implications in the field of modern conservation and restoration of cultural heritage: the 'minimal intervention' concept. Nadolny (2012, p. 578) emphasises that the term 'inpainting' "seems to originate from an early-nineteenth-century American context." The term 'inpainting' enjoys a better position with regard to consistency of definition in literature, as it has been found repeatedly confined within the notion of minimal intervention. For instance, to Mayer (1991, p. 496) inpainting "must be strictly limited to the replacement of missing parts without concealing any of the original paint and without any attempt to 'improve' the picture with new paint." Cove and Cummings (1990, p. 48) say that "the term 'inpainting' can genuinely be used where the paint applied by the conservator is strictly limited to the area of loss" but, in their opinion, this term can be only used to describe the reintegration of "discrete losses of paint." while for large areas of loss, where parts of the original design of a painting are missing, they prefer to call the procedure of compensating them: "retouching." Cove and Cummings made such a preference between the two terms to directly describe, and justify, their image reintegration approach towards portrait paintings done by William Larkin between the years 1610 and 1619. In this context, they meant by 'retouching' particularly the approach they chose by which they justified complete 'reconstruction' of "areas where pattern and detail are vital and the original design is clear such as lace, embroidery and carpets."

Retouching is probably one of the most frequent terms used throughout the English literature written on the conservation of paintings. Nadolny (2012, p. 578) says about the origin of the term 'retouching': "the lack of consensus on retouching methods may account for the fact that the painters term 'retouching' (signifying final adjustments) was appropriated for restoration, rather than a more specific appellation such as *pointiller*²⁸."

Ruhemann differentiates between 'reintegration' which he defines as "careful retouching of gaps" and 'compensation' which he defines as "reconstruction of missing design." It can be understood from

²⁸ *Pointiller*, a French term "used to distinguish inpainting from overpainting. When well done, only persons who are highly trained are able to discern the difference between original and retouching with the naked eye alone, if at all." (Nadolny, 2012, p.575)

those latter definitions by Ruhemann that ‘reintegration’ means imitative retouching, while ‘compensation’ means non-imitative retouching, although one may also argue that those two definitions sound too vague to draw a clear line between the two of them.

Poulsson keeps pointing out, rightfully, to the inconsistency, inter-changeability and confusion that these terms cause. She lists a number of reasons which, in her opinion, cause such issues in the terminology related to the reintegration of image. For instance, she says that “the negative associations attached by some to the word ‘retouching’ have caused conservators to invent new expressions which are used in addition to traditionally used terms.” Another reason, in her opinion, is that the process image reintegration involves a number of “steps” which are eventually “bound to overlap causing more confusion in terminology.” (Poulsson, 2008, p. 4)

Brown and Bacon (2002, p. 5) define the term ‘image reintegration’ as “an aesthetic procedure that replaces areas of media that have been lost or damaged.” In the researcher’s opinion, this definition is coherently constructed in a clear and yet a fairly short sentence. It provides a thoughtful construction of a typical type of conceptual definitions (Parry and Hacker, 1991, p.98), in which the term is distinguished by a description (aesthetic procedure) and by its function (replaces areas of media that have been lost or damaged). This distinguishability becomes clearer as the authors immediately afterwards emphasise that “the technique is not intended to stabilize the condition of the object in a physical sense” (Brown and Bacon, 2002, p.5) in reference to the difference between the conservation and restoration of artworks. This, however, is not a lexical definition as it is intended to be used within the context of art restoration. In this sense, one would be able to argue that other terms commonly used to describe this technique, such as; retouching and in-painting, could all be brought under the same umbrella of this one collective, comparatively consistent, term; image reintegration.

The diagram (Figure 47) is presented to provide a visual demonstration of what is proposed by the researcher in favour of consistency of the definitions of the well-known terms related to the subject of image reintegration. The term ‘image reintegration’ is placed on the top of the diagram, from which there are branches to related terminology. These terms are often perceived as interchangeable to each other and accordingly to ‘image reintegration’. The rationale behind this demarcation and hierarchical order proposal of these terms can be discussed in as follows:

As earlier mentioned, the term ‘image reintegration’ and the definition associated with it as introduced by Brown and Bacon, can be considered as a collective term. In other words, this term covers a broad range of objects on which there are two-dimensional ‘images’, and in the meantime it covers all types of retouching that can be applied for the purpose of aesthetic restoration. This proposal, visualised in the diagram in (Figure 47), classifies retouching into two categories, branched under the term ‘image

reintegration’; interventive retouching and non-interventive retouching. Interventive retouching includes any retouching approach which requires compensation for areas of loss by means of adding materials (e.g. fillers and paints). On the other hand, non-interventive retouching is to compensate for areas of loss by means of a non-invasive method. The only application one can think of, with regard to non-interventive retouching, is the recently developed method of ‘light retouching’, if we could name it, i.e. the use of light as a tool for retouching. This method has recently applied to a number of paintings by Mark Rothko at the Harvard Art Museums. Further details on this interesting project shall be provided later in the ‘approaches to image reintegration’ section of this chapter. The actual existence of this non-interventive-retouching method supports justification of choosing ‘image-reintegration’ to be the collective term, because it can be generalised to include both traditional and unconventional retouching methods, even possibly those which are yet to be developed and introduced. The traditional approach that we here call: ‘interventive retouching’ can also be divided on the basis of imitative or non-imitative. Non-imitative retouching is any minimalist approach of loss compensation with which a restorer avoids making a retouched area appears ‘seamlessly’ fitted into its original. The latter can be branched to two main non-imitative methods: *Tratteggio* (hatching) and the neutral retouching method, both developed in the Italian school of art conservation.

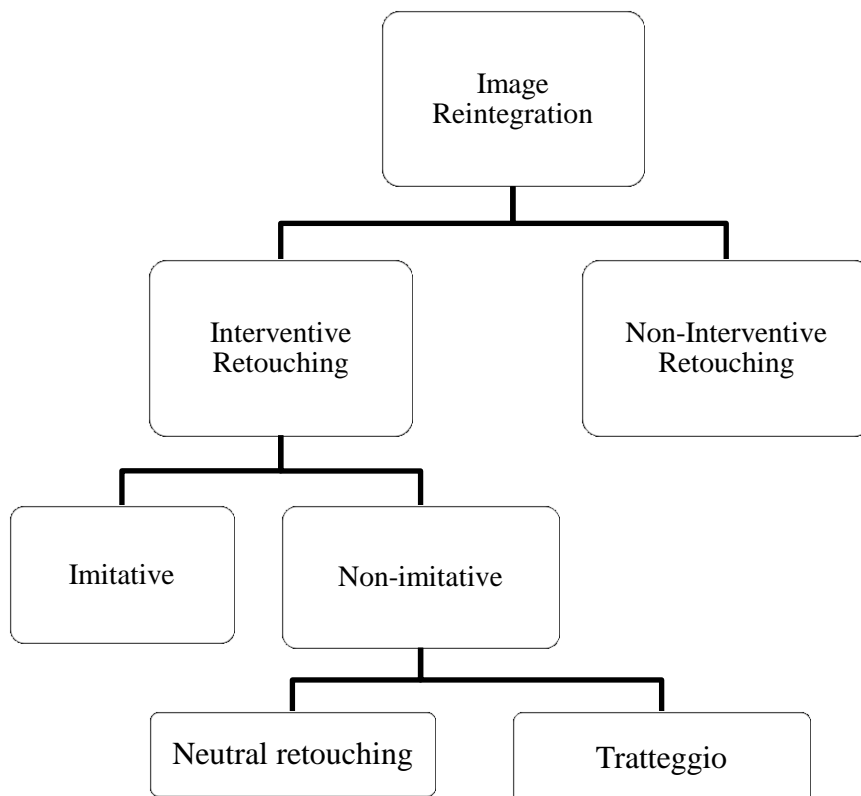

Figure 47: This diagram shows a proposed hierarchical relationship among a number of collective and sub-collective terms that represent approaches to the aesthetic restoration of two-dimensional works of art. This is an attempt to achieve a more proper and meaningful classification of such terms of which

some are found to have been used interchangeably in literature. This diagram is also intended to visually demonstrate the demarcation that can be drawn among these terms in order to maintain the approach that each term represents. It would be important to note that approaches that lie out of the scope of the principle of minimal intervention – notably ‘overpainting’ – are not represented in this hierarchal terminology. Such approaches are generally abandoned in modern art conservation.

4.3 History

From the preceding dialogue it is clear to see that the subject of image re-integration is complex and supports strong and often diametrically opposing opinions with regard to the aesthetic consideration, ethical implication and technical application related to it. A fairly long history of art restoration and conservation, associated with the history of the Western art itself, bears in the core of it continuous thoughts and debates on the various aspects associated with the subject of image reintegration.

Easel paintings, in particular, enjoyed significant interest in the research and study on the various aspects of image re-integration. This is clearly shown in the relatively large body of published literature of which numerous writings are solely dedicated to the subject of image reintegration, either from technical or theoretical perspectives. In the context of complaining from the insufficiency of publications to deal “specifically with collections of artwork on paper,” Brown and Bacon (2002, p. 10) state that “this situation contrasts sharply with other conservation disciplines, in particular easel paintings, which have published widely on the subject [of image reintegration].” There are readily available bibliographic lists of literature on the subject of image reintegration in English as well as other languages, such as “Bibliography: Mastering Inpainting” compiled by James Bernstein and Debra Evans (May 2009), and “Les matériaux pour la retouche : présentation, choix des matériaux” compiled by the Institut national du patrimoine (October 2012). Those bibliographic lists offer a good indication on how much is written on the subject of image reintegration through the various aspects associated with it.

Nadolny (2012) wrote an interesting article entitled “History of Visual Compensation for Paintings,” in which she provided a useful table to include a “spectrum” of approaches to image reintegration – which she prefers to call “visual compensation²⁹”. This table is divided mainly into the two concepts under which image reintegration would be done:

²⁹ The term ‘visual compensation’ is used specifically in modern North American literature on art conservation synonymously to the term ‘image reintegration’ which is primarily found in European literature on art conservation written in English.

- The first and the old concept is what we can call the ‘non-minimal approach’ which according to Nadolny (2012, p. 574) includes “obscuring original surface” by the method known as ‘overpainting’, and “transparent glazes applied over original substance” by the method known as ‘glazing/ toning down/patina’. Apparently, every professional now knows that this concept is abandoned in modern conservation, but it is still useful to learn that overpainting was being employed “from the earliest times”, and then by the 1700s objections started to be raised against such an approach. Glazing (also named ‘toning down’ or ‘patina’), which may be employed to “reduce the prominence of historically significant additions”, Nadolny mentions that it has been “used throughout history,” but now it is “in limited use in many countries.”
- The second concept is what we can call the ‘minimal approach’ which became an essential and integral part of the modern conservation of fine art. Nadolny (2012, pp. 575–578) chooses the title “reconstructive inpainting, only in areas of loss” for this concept and she puts under this title a number of different methods range from “fully mimetic” which means “Retouching that seeks to ‘match’ the losses to the surviving areas as perfectly as possible” down to “minimalist approach” which simply means doing nothing to compensate image losses. The latter approach, however, has been rarely used in the conservation of easel paintings.

It is worthy to point out that Nadolny built up her classification of the image reintegration – or visual compensation – approaches based on their compliance with the principle of minimal intervention, i.e. from “invasive to minimalist”. Additionally, Nadolny’s classification makes no mention of the non-interventive image reintegration approach, which is an approach that holds a promising future.

Nadolny (2012, p. 583) also provided an important and informative “list of conferences dedicated to, or with notable sessions on, visual compensation of paintings held in Western Europe and North America.” The list starts with a conference held in 1928 in Cologne, Germany, and ends with the series of conferences held by the Association of British Picture Restorers and co-sponsored by ICON between 2005 and 2007.

Media and materials used for image reintegration constitute a fundamental part of the complex of factors that impacted the development of the profession across its history. The current plethora of synthetic and natural pigments, fillers, paint vehicles and other additives – not to mention digital means – is gradually employed in image reintegration as a result of an accelerating process of development to art conservation throughout the second half of the Twentieth Century. Ackroyd (2010, p. 51) asserts that “artists’ oil colours or natural resin media were the most frequently employed retouching materials” for the paintings collection in the National Gallery of London during the period from “the early Nineteenth Century to the end of the Second World War.”

The conservation department of the National Gallery, established in 1947, gave rise to different approaches towards the media that were traditionally used for image reintegration, and accordingly “oil and natural resin media were largely discarded” by 1960s, thanks to new systems developed by Helmut Ruhemann who employed egg tempera and synthetic resins, “e.g. the polycyclohexanone resins, AW2 and MS2A, and an acrylic resin, Paraloid B-72,” (Ackroyd, 2010, p. 51). “Since the 1960s, Paraloid B-72, and from the late 1990s, Gamblin Conservation Colors (based on an aldehyde resin), have been the most commonly employed retouching media, used solely and not in combination with other materials,” (Ackroyd, 2010, p. 51). Nicolaus (1999, p. 281) backs this information via a survey conducted in 1971 by Jerzy Wolski who concluded that, at the time, “synthetic resins have been largely welcomed and used in practice [of image reintegration],” in England, Switzerland, Germany and the USA.

That all indicates three phases through which the practice of image reintegration developed with regard to materials:

- Up to the mid-20th Century: despite attempts³⁰ to study the use of better materials, the readily available materials for painting were also used for image reintegration (restoration).
- Between the 1950s and the 1960s: the gradual accumulation of awareness of the negative issues accompanied by the use of traditional materials, such as darkening and discolouration, eventually led to “the selection of more stable synthetic³¹ materials.” (Ackroyd, 2010, p. 51)
- From the early 1990s: rather than only selecting from commercially available materials, attempts were made in order to create specialised materials for image reintegration. Notably was the work done by Robert Gamblin who joined forces with E. René de la Rie and with the participation of Mark Leonard and Jill Whitten. The team proposed paints based on a urea-aldehyde resin, now commercially available under the trade name *Gamblin Conservation Colors*. Those speciality paints were claimed to be stable, reversible and with excellent lightfastness (Leonard *et al.*, 2000), and they were later commended for paintings’ image reintegration by Dunkerton (2010, p. 100) who, based on practical experience in the National Gallery of London, says: “too often conservators have to work with and adapt materials that

³⁰ Nicolaus (1999, p. 283) mentions early experiments with and recommendations of use of synthetic resins, such as polyvinyl acetate (PVAC) that was proposed in 1930, at the Rome Conference of Conservation, by George Leslie Stout who later, in 1944, along with Rutherford J. Gettens recommended its use for retouching. Other synthetic resins, such as polyvinyl alcohol (PVA) and polycyclohexanone, were also proposed and studies. However,

³¹ Ackroyd (2010, p. 58) mentions B-72 resin in xylene as being “the standard medium used for retouching” in the National Gallery since the early 1960s.

have been developed for other purposes; now that we have retouching paints designed for this purpose, it makes sense to use them.”

Ruhemann (1968, p. 243) once said: “no ideal retouching medium is yet known”, his statement is apparently valid until today, and is highly likely to be valid forever. Indeed, no panacea has yet been found for every type of general conservation problem, and for image reintegration in particular.

4.4 Approaches to image reintegration

According to the previous demonstration of the terminology associated with image reintegration and visualised by the diagram in (Figure 47), approaches to image reintegration shall be demonstrated as follows:

4.4.1 Interventive Retouching

Developed through centuries from overpainting to minimalist approaches, interventive retouching became looked at as one of, if not the, most controversial practice in the field of art conservation. Nevertheless, it is yet one of the most commonly practiced treatments, particularly for traditional easel paintings. Ruhemann (1968, p. 240) says: “old paintings are very rarely found in which cleaning does not reveal some losses previously unsuspected, at least by the layman.”

4.4.1.1 Imitative

Sir Isaac Newton, in a famous quote, about the relationship between physical properties of light and color perception asserted:

"The rays, to speak properly, are not colored." This quote underscores a fundamental fact about color perception. Color is a property of percepts produced in observers rather than a property of light energy. Thus, even though we speak colloquially using terms such as "red light," we really mean "light that has an appearance of being red when viewed by a human observer with normal color vision."

(Boothe, 2002, p. 192)

It is now well known that the colour perception is a far more complex process than it was thought in the past³². Humanity long thought that it is the eye which produces light until we figured out that light is an external entity by which we can see the materialistic surroundings. Humanity was similarly long ill-informed about the nature of ‘colour’ and the nature of perceiving it. Without logging into too much of such a complex subject, it matters here to note that now we know that the human eye, or

³² “W. E. Gladstone's 19th-cent. philological studies of Greek colour terms led him to conclude that the Greeks suffered from defective vision (1858). More recently, in the wake of Berlin and Kay (1969), ancient colour perception has been a locus for debating cross-cultural universals and cultural relativism.” (Clements, 2012)

rather the human visual system, has its shortcomings with regard to colour perception. One limitation is that the human eye can perceive ‘colours’ that only exist between approximately 400nm to 700nm. This is the range of what is anthropocentrically called the ‘visible spectrum’ with which a number³³ of colours is discernible to our naked human eye. Luckily for restorers, visual limitations can be considered beneficial when it comes to image reintegration. Let us imagine that, instead of being trichromats³⁴, we have pentachromatic³⁵ vision found for example in butterflies (Arikawa, 2003) or pigeons (McGraw, 2004). Such a more complex visual system enables those species to theoretically perceive a wider range of wavelengths in the electromagnetic spectrum. In other words, they can theoretically perceive more ‘colours’ than we can. If our visual system had such advanced colour perception boundaries, like those of butterflies or pigeons, restorers would have had a hard time trying with great difficulty to deceive people’s naked eyes with any of the current approaches to image reintegration, particularly the imitative approaches.

Imitative retouching of a painting is about deceiving a human eye into perceiving an image of a painting with a continuous surface with no ‘visual interruptions’ resulting from the defective areas that are present. The difference between past and modern imitative retouching is obviously the principle of minimal intervention which ethically prevents modern conservators from carrying out excessive retouching, or the so called ‘overpainting’, that does not exclusively conform to the lacunae.

³³ It is obvious that there is no reliable data with regard to the number of colours discernible by us. Several published writings concerned with colour theories and human visual system state hugely different numbers that range from few thousands to few millions of discernible colours (Saunders, 2000, p. 3), (Linhares, Pinto and Nascimento, 2008). This inconsistency of information is noted by Thompson (1995, p. 48) who asserts: “It is often said that human beings can distinguish more than a million different colours.” Furthermore, Thompson describes such statements as “actually rather misleading.” However, he clarifies: “but we can see what it intends by referring to the dimensions of hue, saturation, and lightness as displayed in the colour solid. Along the hue dimension we can distinguish approximately two hundred steps from yellow through green and blue, and finally to red. Along the saturation dimension we can distinguish at least twenty steps for any hue. Finally, we can distinguish about five hundred steps along the lightness dimension. Combining these figures gives us more than a million possible distinctions. In this sense we can discriminate more than a million particular determinate colours or shades.” (Thompson, 1995, p. 48)

³⁴ Trichromats are the mammal species – notably humans and a number of other primates’ species – which have “the visual system of three types of cone receptors, each containing a spectrally distinct photopigment.” (Jacobs, 1997, p. 47)

³⁵ Unlike humans who normally have three types of cone receptors in their retinæ, some birds and insects species, notably species of butterflies and pigeons, have five and therefore they can theoretically recognise much more ‘colours’ including many that we cannot perceive.

4.4.1.1.1 The case of Barnett Newman's *Cathedra*

In an important account (Bracht, Glanzer and Wijnberg, 2003, p. 27) written about problematic conservation treatment for a severely damaged painting by Barnett Newman, the authors provide interesting information about the imitative image reintegration they tackled. Barnett Newman (1905-1970) is an Abstract Expressionist and a pioneer Colour Field painter. The subject of that conservation treatment, which was carried out in 1997-98, is one of the Newman's paintings held by the Stedelijk Museum in Amsterdam. The painting is titled '*Cathedra*' (1951) 2.43m x 5.43m, painted with oil and magna³⁶ on canvas (Figure 48). It was attacked in November 1997, while on display at Stedelijk Museum, by a vandal visitor, slashing it with a sharp object (Vogel, 1997). The account given by the authors on the image reintegration part of the conservation treatment of *Cathedra* clearly show the amount of difficulties they encountered because of the paint application the Barnett Newman used. The authors describe how they thought that retouching such a monochromatic painting would be easy, and how they found out "how wrong they were" afterwards:

We did not expect to have any great difficulty with the retouching. The filler was already a bright blue colour and it would only need a few touches of a darker colour. How wrong we were! Before we could begin the retouching the areas of paint bordering the slashes -which were either too matt or too glossy would have to be matched to the rest of the surface. To do this we used very thinned Paraloid B72 (poly ethyl methacrylate-comethyl acrylate) or a matt gouache paint. *Cathedra*'s ultramarine blue consists of five layers of different tones of paint, in which it is the size of the pigment particles and the crystal blue of synthetic ultramarine above all that determines the colour. Since ultramarine in oil has only poor covering power, the light penetrates deep into these various layers and this refraction brings different shades of tone to the ultramarine. We had to imitate the various blue tones, which ranged from an intense bright ultramarine blue to a blue with violet, red or orange overtones and an almost black-blue tending towards a green or brown tone. In addition to this in some areas the binding medium Magna had added an iridescent gloss producing various shades of colour. These are rather like bronze, being either reddish, orange or greenish in colour. Using blue and violet watercolour, gouache and acrylic colours mixed with pigments such as spinel black, madder and various cadmium colours, we tried to match the fills in *Cathedra*'s blue areas. As we had been unable to match Newman's blue in our dummies we could only try it out on the original. Each of us only managed to retouch about 15cm per day, constantly changing the composition of our colours to imitate the different shades and surface gloss as closely as possible. The retouching was very tiring for our eyes. After several hours we were incapable of distinguishing between the different blue tones any longer. We found it difficult to recognise and accept the limits of our capabilities when we found that we could only provide an approximate match for this particular blue.

³⁶ Magna is a brand name of an acrylic solution medium that was developed by Bocour Artist Colours and became available in the mid 1940's (further detail in Chapter 3).



Figure 48: Barnett Newman, *Cathedra*, (1951), 2.43m x 5.43m, oil and magna on canvas (courtesy of Stedelijk Museum Amsterdam)

In a later section in this chapter on ‘non-interventive retouching’, we shall discuss the case of Mark Rothko’s *Harvard Murals*, which are very similar to the abovementioned case of Newman’s *Cathedra*. A discussion on how a non-intervention method, for image reintegration used in the Rothko’s case, overcame problems encountered in the Newman’s case.

4.4.1.2 *Non-imitative*

According to Muir (2009, p. 22), non-imitative retouching had been used “well before the twentieth century”. Muir furthermore states that “it is documented that Carlo Maratta used a hatched (*tratteggio*) technique in his restoration of Raphael’s *Psyche Loggia* in the late seventeenth century. Conti mentions the use of pointillist techniques in the 1800s.”

“In 1914, the German restorer Victor Bauer-Bolton argued that retouching should be clearly identifiable and proposed a method whereby the loss was filled and retouched at a slightly lower level than the original painting. Significantly, he also recognized that the retouching approach largely depended on whether the painting was considered primarily as a work of art, a historical document, or a commercial object.” (Muir, 2009, p. 22)

In the 1920s, it was Max Doerner in Germany, and Edward Waldo Forbes and R. Arcadius Lyon in America who promoted the use of ‘hatched retouching’ which is a form of non-imitative image reintegration techniques (Nadolny, 2012, p. 581). Later the method was even further influenced by the writings of the Italian art historian Cesar Brandi (1906-88) who criticised traditional restoration, and his opinion was that it affects the integrity of the artworks. His *Theory of Restoration*, which was first published in 1963, gained wide recognition. “In the 1940s and 1950s, with the support of Brandi, the restorers Paolo and Laura Mora developed a system of visible compensation – *tratteggio* (also known

as rigatini) – based on superimposed vertical brush strokes of transparent watercolours. Brandi’s recommended approach eschewed the extremes of mimetic retouching and minimalist rejection of restoration as respectively historically dishonest and unaesthetic and promoted the use of *tratteggio* both to achieve differentiated mimetic effects, or, to create ‘neutral’ tones (depending on the nature of the loss),” (Nadolny, 2012, p. 581). Despite being recognised and admired, conservation practice in the Anglo-Saxon world was not effectively influenced by Brandi’s writings, and imitative interventive image reintegration remained the most established method in countries like the UK, the USA, Germany and the Netherlands.

4.4.2 Non-interventive Retouching

To the best of the researcher’s knowledge this is the first piece of writing, in the field of art conservation, in which the term ‘non-interventive retouching’ is proposed and discussed. There is probably only one published written work in which this term is mentioned, however within a completely different concept. This published written work is the book titled; *Retouching of Art on Paper* written by the conservator at the Norwegian Nasjonalmuseet for kunst; Tina Grette Poulsson, who attempts to differentiate between interventive and non-interventive retouching, as can be seen in her following statement:

“Interventive retouching on an original surface requires the consideration of several important ethical issues such as reversibility and authenticity. The use of retouching on infills, which could be termed non-interventive, is easier to accept, as it can always be made reversible and can normally be easily identified as a later addition to the original work.” (Poulsson, 2008, p.3)

Arguably, Poulsson, in the previous statement, uses ‘non-interventive’ inaccurately to describe what is known in the field of art conservation as ‘minimal intervention’. The difference between the word ‘minimal’ and the prefix ‘non-’ is obvious, and albeit retouching is exclusively done on infills, this should be by all means described as ‘interventive’.

‘Non-interventive retouching’ is to image-reintegrate the surface of a painting while avoiding adding paints or other materials on that surface. In other words, it is about retouching the surface of a painting without actually touching it, and this is the only way with which ‘non-interventive’ makes sense. But the question that might be raised now; is this concept applicative? In fact, it would have been unimaginable to think of an actual application of the concept of non-interventive retouching without the recent technological and digital advances that recently enabled a number of conservators and conservation scientists in Harvard Museums to aesthetically restore, using an innovative and unconventional method, a suite of five paintings by Mark Rothko, the renowned American Abstract Expressionist painter (1903-1970). The story behind those notoriously problematic paintings, and the

unconventional non-interventive reintegration method used to restore them, are presently mentioned in detail.

4.4.2.1 The case of Rothko's Harvard Murals

Those paintings by Rothko are known as *Harvard Murals*. Despite what the word ‘mural’ in this title suggests, the five paintings are on canvas, large in size, hence the name. They consisted of two individual paintings and a triptych (Ball, 2001, p.374). According to various reports; unknown (1963), Annicchiarico (2014), Walsh (2014) and Shea (2014a) the paintings have been commissioned in 1961 by Harvard University³⁷ from the artist to be installed in a dining room at the Holyoke Center (now the Smith Campus Center), one of the university's buildings (Figure 49). “Satisfied” that his paintings were going to be displayed at Harvard, Rothko insisted not to be paid for that suite of paintings that were valued at the time at \$100,000. Rothko, however, identified a number of conditions; he stipulated that “the public be allowed to view the paintings as much as possible” (unknown, 1963), that the paintings “always be hung as a group” and that the drapes in the dining room always be drawn closed³⁸ (Figure 50), (Figure 51).

Those conditions identified by Rothko were probably too unreasonable to be practically adhered to. The poorly chosen place combined with poorly chosen materials for the paintings led to both natural and man-made types of degradation. Marjorie Cohn, a retired Harvard curator and conservator who was, as a trainee at the Harvard Art Museums around the time Rothko was commissioned, recalls that despite the authorities at the time had been keen to adhere to Rothko's requirements, it was practically impossible to prevent visitors from inadvertently abusing the paintings. “They could care less about Rothko murals. They were there for a party, and they opened the curtain to look at the view, and you really can't blame them,” Cohn says (Shea, 2014a). Eventually, the paintings “became so damaged by sunlight and splattered with cocktails and food,” along with a number of tears, dents, scratches and abrasions³⁹, and after only about 16 years of display (they had been on display from 1963 to 1979), the paintings were all removed from their room in Holyoke Center.

³⁷ Harvard Murals were commissioned to Rothko by Wasily Leontief, president of the Harvard Society of Fellows (Rothko and López-Remiro, 2006, p.148)

³⁸ For the reader who wishes to wade through further details on the circumstances and consequences that surrounded the *Harvard Murals* commissioned to Rothko, it might be interesting to have a look through the chapter on the story of those particular paintings in (Breslin, 1993, pp.445-457)

³⁹ “Officials at the Fogg wrote memoranda urging that the curtains be kept closed, that the waitresses be careful, the cleaning men be careful, but without too much effect. Alternative locations for the paintings were sought but none found. In 1973 a seven-inch tear was found in Panel Four, which was removed from the room for conservation treatment. By 1979 the most distinguished dining room at Harvard University had been democratized into the Party Function Room, rented out during the week, scene of banquets, seminars and, in one

The colour-fading problem associated with this suite of paintings has been long known to the authorities and conservators at Harvard Museums. This problem is due to Lithol Red that Rothko used in those paintings. To achieve certain shades of crimson red, Rothko employed Lithol Red in mixtures with other synthetic ultra-marine, cerulean blue, titanium white and Naphthol Red (Ball, 2001, p.374). According to Jens *et al.* (2010, p.147) Lithol Red is a 20th Century β -naphthol pigment lake that occurs as salts of a synthetic dye and it was “one of the commonest 20th century red synthetic organic pigments”. Further details on the problem caused by this pigment, and which led to a dramatic change in the colours of the *Harvard Murals*, are given in the following statement:

“Although commonly used in the printing industry for its brightness and bleed-resistance, Lithol Red has the reputation of being extremely light sensitive and its presence has been identified as the cause of dramatic color changes in a mural cycle by Mark Rothko, known today as his *Harvard Murals*. Called murals only because of their size, these five paintings on canvas were on permanent display in a room with floor-to-ceiling windows in the Holyoke Center, Harvard University from 1963 to 1979... Due to the poor lightfastness of the synthetic organic Lithol Red pigment and the excessive light exposure, the background color in the paintings changed from crimson towards a light blue. The degree of the color change varies from painting to painting and also within single paintings depending on their location in the room. (Jens *et al.*, 2010, p.148)

Reportedly, the fading process occurred shortly after the installation of the paintings in the dining room of the formerly called Holyoke Center. At that time, the authorities in Harvard Museums were becoming concerned about what appeared as drastic changes in the original colour in the paintings as the reds were rapidly turning to blues. Rustin Levenson, a New York-based painting conservator, recalls: “I was among the conservators at the Fogg Art Museum responsible for checking on them [i.e. *Harvard Murals*] after their installation. Within a short time, it became clear that the crimson works were fading radically,” (Spencer and Thaw, 2004, p.126). In 1967, about three years since the first installation of *Harvard Murals*, the director of Fogg Museum at the time, John Coolidge, wrote a letter to Harvard's recording secretary at the time, Eugene Kraetzer, stating that the paintings were “in appalling shape. They have faded and changed color variably and in some cases extremely,” (Breslin, 1993, p.455). Coolidge also suggested contacting Rothko to discuss that matter with him. One conversation has been had with Rothko with regard to that problematic issue in which he maintained that he used commercial paint at one point when he ran out of paint⁴⁰. He also refused a suggestion of giving the paintings “a light spray-coating of polyvinyl acetate to protect them,” responding to this

case, an end-of-the-term disco party. In just the fourteen months between February 1978 and April 1979, a conservation report revealed, the works had suffered a number of scratches and abrasions, one had a two-inch tear, another a dent three inches in diameter, and one ALAN C had scratched his name into the paint of Panel Three.” (Breslin, 1993, pp.456-457)

⁴⁰ Breslin (1993, p.455) doubts that claim by Rothko, exclaiming: “yet all of the mural panels suffered damage wherever they were exposed to sunlight, a result that can hardly be attributed to a substitute can of paint or two.”

suggestion by saying: “there is really nothing I can do, I’m afraid, about the deterioration of poor paint,” “so Harvard did nothing, and blamed the artist,” (Breslin, 1993, p.455). Although Rothko was blamed for his poor choice of Lithol Red⁴¹, it seems that it was a premature judgment. Jens *et al.* (2010, p.148) and Standeven (2008) exonerate Rothko of holding responsibility, at least alone, as they assert that the pigment had had no bad reputation back in the early 1960s when Rothko started work on his murals. They both quote from (Gettens and Stout, 1966) who thought that “Lithol Red has good stability to light and heat.” At all events, Rothko committed suicide in 1970, and no one managed to reach “remedial measures” for *Harvard Murals* with him prior to his tragic death (Bethell, 1988, p.30).



Figure 49: Conservators install *Panel One* of the *Harvard Murals*, Holyoke Center, January 1963. (Elizabeth H. Jones/President and Fellows of Harvard College) (Shea, 2014b)

⁴¹ Back in 1988 the *Harvard Murals* were temporarily re-displayed, for the first time since they were removed from Holyoke Center, in a retrospective exhibition from 6 August to 2 October at Harvard’s Arthur M. Sackler Museum. The former Harvard Museums conservator Marjorie Cohn, who was the curator of that exhibition, accused Rothko of being completely “ignorant” of, or “indifferent,” to “the most basic requirements for permanent painting,” (Bethell, 1988, p.31). On the same occasion of that exhibition, Edward J. Sozanski, an art critic, similarly accused Rothko as he wrote that the artist “ignored or dismissed the technical exigencies of painting,” and that he “through ignorance or indifference, he failed to make paintings that would stand up to the rigors of the environment in which he placed them.” (Sozanski, 1988)



Figure 50: Mark Rothko's *Harvard Murals* — Panel One, Panel Two and Panel Three — Holyoke Center, January 1965. (Courtesy of Harvard University Archives) (Shea, 2014b)



Figure 51: Panel Five of Rothko's *Harvard Murals* hangs in Holyoke Center in January 1968. (Courtesy of Harvard University Archives) (Shea, 2014a)

4.4.2.2 The non-interventive image reintegration of Rothko's Harvard Murals

It was only until recently⁴² when Rothko's *Harvard Murals* were decided to undergo image reintegration treatment in an attempt to restore their original colours (Figure 52). A number of researchers collaborated in this project and came from various backgrounds in the fields of art history, art conservation, conservation science and IT engineering. They describe and discuss in detail in their

⁴² The outcome of this project was published in 2011 (Cuellar *et al.*, 2011)

paper (Cuellar *et al.*, 2011), with which they participated in ICOM-CC 16th Triennial Conference in Lisbon, their method of restoring *Harvard Murals*. Their method to restore the colours of those paintings is a non-interventive retouching technique using ‘light’ instead of paints. Narayan Khandekar, senior conservation scientist at the Harvard Art Museums and member of the project’s team, describes the project in his own words: "what we're doing is using light as a retouching tool, in the same way that when you restore a painting, traditionally you use paint to restore the lost colors. In this case we're using light to fill in those missing areas," (Shea, 2014a) (Figure 53).

The technique of this non-interventive ‘conservation treatment’ completely relies on the use of a system that includes digital cameras, computers and projectors. The team created mock-ups that resemble Rothko’s painting in pigments, binding media and canvas support. Those mock-ups were intended to be used for testing equipment and developing software used in that project “without experimenting on the original art work” (Cuellar *et al.*, 2011, p. 3). Reference images were taken for the mock-ups to serve as ‘target’ images before they underwent accelerated photo degradation with total light exposure of eight thousand lux hours. The now-faded mock-ups were digitally photographed and ultimately compared to the target images using specialised software. The software used the information to finally create ‘compensation’ images which transferred to a projector in order to visually retrieve the original colours in the faded areas of the paintings’ surfaces.

Following procedures of testing and improvement to the technique, similar steps were applied to the real paintings. The reference images by which the team compensated for the faded colours in Rothko’s paintings were away from being subjective. In order to create the reference, or target, images of two important sources were used; the first source was “color-restored photographs of the Murals in their original condition in 1964,” and the second source was “reference colors from an unused sixth panel⁴³ in the series,” (Cuellar *et al.*, 2011, p. 2). The final step was to allocate a projector for each of Rothko’s faded paintings. The projectors were suspended from the ceiling to cascade the carefully calculated pixels of illuminated colours on the faded areas of the paintings, by which this system of non-interventive restoration is eventually completed (Figure 54). According to Mancusi-Ungaro, conservator and director of the Rothko research project, this system enabled the conservation team “to color correct, pixel by pixel, specific areas, without flooding the entire painting with a colored light,” (Shea, 2014a). He adds that the system also enabled the members of the research team to carry out their technique “without physically touching the painting.” The technique is conceivably complicated, and the researchers in this Harvard Murals project did spend years to

⁴³ The sixth painting was created by Rothko at the same time with the other five paintings. “It stayed rolled up, safe from booze and light damage. With access to that, the conservators had a benchmark for the original colors.” (Shea, 2014a)

“develop this new technique, and they're still tweaking it with help from the MIT Media Lab's Camera Culture group and Swiss researchers,” (Shea, 2014a) (Figure 55).

With regard to the potential impact of using projected light onto such highly sensitive areas containing Lithol Red, Cuellat *et al.* (2011, p. 7) maintain that the overall illumination for Rothko's paintings, particularly for Panel Five which is the most severely colour damaged, combined of 25 lux from the ambient light plus 25 lux from the projector light. This means that the overall illumination output was 50 lux which were chosen by the Murals' conservation team and backed up by a standard that was set by Thompson (1994)⁴⁴. In addition to what have been indicated as 'cons' of this approach, it is probably best suited for museums or public galleries. Conceivably, less than a few private owners and collectors would see feasibility in this method.

In this case of Rothko' Murals, the use of conventional interventive methods of image-reintegration would have led to serious infringement to the principle of minimal intervention which has become commonly regarded as a fundamental principle in the field of art conservation⁴⁵. On the one hand, this is because the damage occurred to large areas of the paintings. Furthermore, this is because the type of damage is colour fading, which means there is no paint loss that could be compensated. This simply means that the only interventive solution to correct the faded colour would be repainting, which is an act that would be regarded utterly and totally unprofessional and unacceptable, to be carried out.

4.4.2.3 Previous attempts to use projected illumination for non-interventive restoration

Earlier attempts to use illumination to alter colour appearances on paintings and other objects have been made. Cuellat *et al.* (2011) point out to the first attempt of such a method that was carried out

⁴⁴ Joyce Townsend *et al.* (2007) in a presentation titled: “Light stability of colorants in museum collections: Are we still in the Dark Ages?”, however, give a critique to the rule of 50 lux for light-sensitive objects. They describe the rule as “misinterpreted”, because it was accordingly assumed that “50 lux is safe, higher is dangerous,” which is not always the case, besides it is difficult for some visitors, particularly elders, to properly see the artworks under 50 lux of lighting.

⁴⁵ Under the 21st article of the *Guidelines for Practice* by the American Institute for Conservation of Historic and Artistic Work (AIC): “The conservation professional should only recommend or undertake treatment that is judged suitable to the preservation of the aesthetic, conceptual, and physical characteristics of the cultural property. When nonintervention best serves to promote the preservation of the cultural property, it may be appropriate to recommend that no treatment be performed.” Under the 8th article of the *Code of Ethics* by European Confederation of Conservator-Restorers (ECCO): “The Conservator-Restorer should take into account all aspects of preventive conservation before carrying out physical work on the cultural heritage and should limit the treatment to only that which is necessary.” Under the 2nd article of the *Code of Ethics* by the Canadian Association for Conservation of Cultural Property / the Canadian Association of Professional Conservators (CAC/CAPC) “When conserving a cultural property, the conservation professional shall respect the integrity of the cultural property by endeavouring to preserve its material composition and culturally significant qualities through minimal intervention.”

and presented in a paper by Lafontaine (1986) who employed “a combination of blue and white light to compensate for the yellowness of the existing varnish on a painting by J.M.W. Turner.” Lafontaine wrote interesting remarks and suggestions based on his pioneering illuminating experiment. He suggested that the museums should think of employing such a technique for it is “non-interventionist and non-destructive cleaning” compared to risky traditional varnish removal treatments (Lafontaine, 1986, p. 100). Lafontaine’s project, however, encountered more than a few problems, including trying to find a practical and reliable method of proper compensation with colour illumination, and facing the problem of unequal thicknesses of varnish layers on paintings’ surfaces. Purportedly, apart from one short published article⁴⁶, there was lack of interest in Lafontaine’s work in later literature.

Other attempts of the use of illumination concepts, similar to Lafontaine’s work, were also conducted, such as the ‘three-dimensional virtual restoration’ of “damaged or historically significant objects” carried out by Law *et al.* (2009) who also employed digital equipment and custom-made software in order to create calculated 3-D digitally restored images of the patterns and colours painted on the surfaces of six selected objects including Renaissance figurines and Native American ceramic vessels. Michaela Janke (Sharpe, 2010) used the same principle to “virtually reintegrate” 16th Century secco murals (Broemserhof Renaissance murals), on the ceiling at the Brömserhof Museum in Rüdesheim am Rhein in Germany, that were damaged during the Second World War (Figure 56). As a reference image, a 19th century water colour painting of the murals by German artist Gustav Ballin was used. In the UK, a similar concept was applied as part of a PhD study by Ruth Perkins from Manchester University’s School of Materials who has carried out “digital conservation”⁴⁷,

Despite the earlier attempts to use light as an image re-integration tool the non-interventive image integration of the *Harvard Murals*, Cuellat *et al.* (2011, p. 2) was the first time it was agreed to have succeeded⁴⁸, and to have established a new approach:

⁴⁶ Lafontaine’s study was mentioned in one article; (Naud, 1990, p. 13), four years after his paper published. The article praised Lafontaine’s work and re-stated his previous recommendation to museums to consider the possibility of employing such a technique instead of traditional cleaning methods, particularly for vulnerable paintings.

⁴⁷ ‘Virtual restoration’, ‘Digital Conservation’ and ‘virtual reintegration’: noticeably, different terminology was used by each of the studies that used basically the same concept. It is also noticeable that each report describes its technique as “novel” or “ground-breaking” which presumably indicates that the studies that have employed a method of non-interventive image reintegration using projected illumination are isolated to some extent. Probably a recommendation should be made towards a larger scale of research in this promising area of modern art conservation.

⁴⁸ See previous footnote.

The color reconstruction of Mark Rothko's *Harvard Murals* differs from these works in several ways. On the one hand, one does not have to deal with the three dimensional aspects of a curved paint surface in a vault or on a vessel. On the other hand, one is not filling in complete losses onto a white surface.

4.4.2.4 Pros and cons of the non-interventive image reintegration approach employed in the case of the Rothko's Harvard Murals

Pros: Obviously, the non-interventionist technique provided by this system is the most advantageous aspect in this approach. It raises no concerns with regard to issues like reversibility of added materials or integrity of the artwork due to some interventive treatment. It is difficult to see problems with regard to irreversibility with such a non-interventive approach for image reintegration. It is all about switching 'on' a button so the faded colours appear restored, and it is also all about switching 'off' a button so to reverse the 'treatment' in a glimpse. Overall, this system provides an ethical approach that is arguably unrivalled by any other conventional art restoration treatments, specifically with regard to 'image reintegration' and 'surface cleaning'. Moreover, there can be instances, as previously indicated in the case of the *Harvard Murals*, where no interventive retouching could be or should be carried out, as this would affect the integrity of the artwork. Accordingly, colour restoration via projection can be seen as the best 'ethical' solution available for such cases. Another interesting advantage that can be benefited from this technique is proposed by Law *et al.* (2009, p. 8) in the context of their own project of three-dimensional virtual restoration, but it can still be applicable to the system developed for Rothko's project: "using this system in a conservation lab to enable conservators, curators, and other stakeholders to envision potential results of actual conservation treatments."

Cons: However, there are admittedly quite a few limitations surrounding such an approach. Feasibility and complexity of the technology involved that incorporate both high-tech hardware and software are not the least issues. It is also about the nature of the artwork itself. For instance, in the case of a painting, it should ideally have paint surface that is as free as possible from impasto (which is a typical case with airbrush paintings). Presumably, a painting with impastos of raised brush-strokes or palette-knife-strokes would not appear successfully visually image-reintegrated with illumination, as those impastos would block the light and create patches of shadow wherever they exist on the painting's surface. Therefore, one can think of airbrushed paintings as objects of art that would be ideal for such a non-interventive approach. Another limitation is that it can be difficult to find a reference image by which an objective evidence of the original colours could be reached, as was possible in the case of Rothko's Murals, otherwise decisions would be deemed subjective and might compromise the artist's intention. Furthermore, the energy emitted by the illumination that comes

from a projector might add up to concerns that could be raised with regard to the safety of photosensitive pigments.

At the time of writing this chapter, the Rothko's *Harvard Murals* are currently exhibited, among thirty eight other works by the Mark Rothko done from 1961 - 1962, at Harvard Art Museums from the 16th of November 2014 to the 26th of July 2015. (Cambridge, 2014)



Figure 52: Different versions of the same painting. Left: the Rothko painting in its faded form. Middle: The Ektachrome photo that had turned too red with time. Right: The painting color-corrected back to the original (Everts, 2011)



Figure 53: Conservation scientist Jens Stenger holds a white board demonstrating the noninvasive digital projection of one of the damaged Mark Rothko paintings. (Jesse Costa/WBUR) (Shea, 2014b)



Figure 54: The digital imaging software and tools used to calibrate the color corrections onto the damaged Rothko paintings. (Jesse Costa/WBUR) (Shea, 2014b)

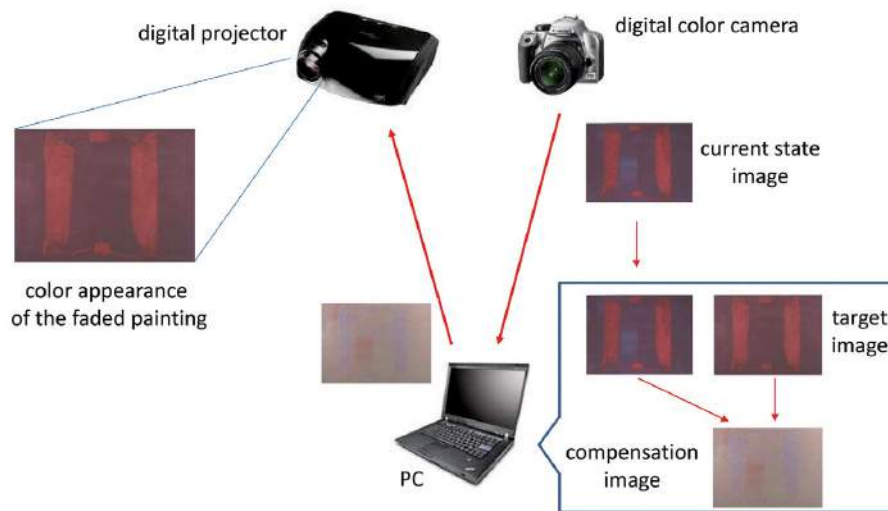

Figure 55: a simplified workflow scheme presented by (Cuellar *et al.*, 2011, p. 4) of the camera-projector system used for the non-interventive retouching of Rothko's *Harvard Murals*

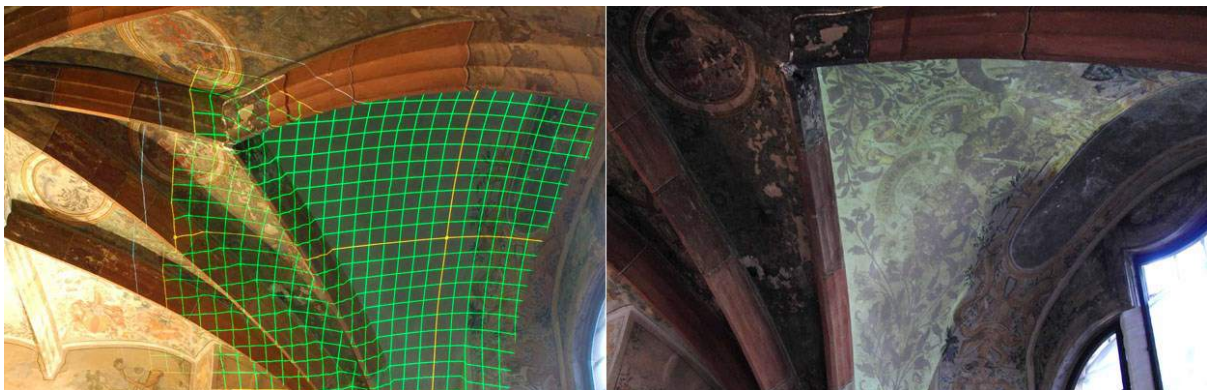

Figure 56: the 'virtual restoration' project for the Broemserhof murals by Michaela Janke: left assessing the topography of an area of loss in the ceiling painting by means of a high-tech system provided by

Coolux GmbH, right: the same area of loss eventually ‘retouched’ with a projected digital image (Photos by Michaela Janke)

4.5 Ethics and Aesthetics: philosophical issues pertaining to image reintegration

There is no doubt that the field of art conservation has become more sophisticated than that existed a few decades ago. Ethical considerations played an essential role towards the development of the profession of art conservation. It was not until the year 1950 when the International Institute for Conservation (IIC) was established by conservators as the “first professional conservation association,” (Sease, 1998, p.98). That landmark was already preceded with intriguing debates questioning several aspects of the profession in an attempt to rationalise, or abandon practices that had been considered acceptable. In the 1920s, Ruhemann states, “the opinion began to be expressed in professional journals that any kind of retouching was an illegitimate and presumptuous interference with the original master’s work (and should be forbidden),” (Ruhemann and Plesters, 1968, p. 255). However, the establishment of the IIC, followed by other national organisations, helped reshape the profession by introducing the first *Standards of Practice and Professional Relationships* (IIC-AG, 1964)⁴⁹ followed by the first Code of Ethics⁵⁰. Remarkably, within a few decades, art conservation had been thoroughly transformed from a mere craftsmanship into a large body of an interdisciplinary professional practice and research.

As discussed earlier in this chapter; the main aim of image reintegration is to maintain the work of art ‘aesthetically’, and it is even described as an “aesthetic procedure” according to the definition given by Brown and Bacon (2002, p.5). It is, however, difficult not to look critically and sceptically at the subject of aesthetics. This, for instance, brought Anatole France to say: “In aesthetics... one can argue

⁴⁹ “The first formulation of standards of practice and professional relations by any group of art conservators was produced by the IIC-American Group (now AIC) Committee on Professional Standards and Procedures. Formed at the second regular meeting of the IIC-AG, in Detroit, May 23, 1961, the committee worked under the direction of Murray Pease, conservator, Metropolitan Museum of Art; other members of the committee were Henri H. Courtais, Dudley T. Easby, Rutherford J. Gettens, and Sheldon Keck. The Report of the Murray Pease Committee: IIC American Group Standards of Practice and Professional Relations for Conservators was adopted by the IICAG at the fourth annual meeting in New York on June 8, 1963. It was published in *Studies in Conservation* in August 1964, 9(3):116-21. The primary purpose of this document was: to provide accepted criteria against which a specific procedure or operation can be measured when a question as to its adequacy has been raised.” (Kushel and AIC, 1994)

⁵⁰ “The first formulation of a code of ethics for art conservators was adopted by the members of IIC-American Group at the annual meeting in Ottawa, Ontario, Canada, on May 27, 1967. It was produced by the Committee on Professional Relations: Sheldon Keck, chair; Richard D. Buck; Dudley T. Easby; Rutherford J. Gettens; Caroline Keck; Peter Michael s, and Louis Pomerantz. The primary purpose of this document was: to express those principles and practices which will guide the art conservator in the ethical practice of his profession.” (Kushel and AIC, 1994)

more and better than in any other subject... Aesthetics is based upon nothing solid. It is a castle in the air. Some have sought to base it upon ethics. But there is no such thing as ethics.” (in Allen and Clark, 1962, p.582)

Anatole France apparently believes, probably rightfully, that Aesthetics is an absolutely subjective subject of philosophy. Similarly, Tolstoy believes that “if one turns to the writers on aesthetics, one finds nothing but confusion” (Hall, 1963, p.133). In this sense, one can argue that such a great deal of subjectivity overshadows image reintegration accordingly. In fact, one can see the struggle of attempting to objectively justify the tendency towards applying certain methods of image reintegration to certain paintings in almost every piece of literature that deals with this particular branch of art conservation and restoration.

In the context of the cleaning of paintings, Gerry Hedley (1990, p.11) points out that image reintegration – which he chooses to call: retouching – can be problematic, particularly after ‘complete cleaning’ of a painting surface. The approach he encourages is to avoid both ‘over finishing’ and, of course, “poor quality retouchings.”

There have always been factors that guided ethical considerations in the art conservation field. One of those factors was the artist’s intention. However, it would be noteworthy to ask what is ‘artist’s intention’ anyway? How could we possibly be sure of an artist’s intention without an explicit statement by the artist her/himself? Even if we learnt the ‘intention’ of a certain artist, would we really be able to fully and comprehensively comply with it, for instance when the materials chosen by that artist acted later in a way that was not anticipated by the artist and which they might or might not have liked? Degradation of a work of art is not always in the mind of the artist or even a consideration and yet it is the very same degradation that has resulted in the development of the field of conservation research and practice. Is it possible to know for sure what an artist, who is now deceased, would think about the validity of any action later applied to their artwork? Would have da Vinci preferred the Monalisa to be exhibited somewhere else instead of the Louvre? The French composer Claude Debussy did not like it when his music was categorised as ‘Impressionist’ (Gagné, 2012, p.136), however he is still associated with Impressionist music. In fact, we can safely say that the artists themselves can, and they often do, change their minds about their artworks. This means that even during their own lifetime many artists have a change of mind about the intentions behind their work?. Wharton (2005, p. 165) asserts: “When the artist is alive and actively expressing his or her intentions, the focus shifts toward documenting and honoring the artist’s interests. Problems arise when artists change their mind or express interests that are either unachievable or undesirable by current owners. Some artists recommend conservation strategies that dramatically alter their earlier work. Some prefer conserving their own art using methods that contradict conservators’ codes of

ethics, such as repainting surfaces and changing original elements. Artists claiming continued rights to alter their work can come into conflict with owners, particularly when greater value is assigned to works from an artist's earlier period." Thanks to the advances in technical examination, many fine artists are now evidently known to have altered or even painted over their own artworks. Picasso is a known example⁵¹.

Should we consider the artist's intention when discussing lighting conditions under which the artwork was displayed? Let us, for instance, think about the pioneer Impressionists who did their paintings in open air under sunlight, and then ask ourselves; were their intentions for their paintings to be displayed and seen under only 200 lux which is the maximum illuminance allowed in museums and public galleries?

There are even more complex factors in addition to lighting conditions that we can ask about, similar to these following questions asked by Kirsh and Levenson (2000, p. 254): "do critics or historians need to account for viewing distance, surrounding visual conditions, and light sources when they discuss a painting's tonality or the readability of details? What about such issues as the effects of changing light recorded by Monet in his serial paintings of the 1890s, the visual impact of Ad Reinhardt's (1913-67) black paintings, and the works of Bridget Biley (b. 1931), which involve afterimages? Should these factors be considered when making use of contemporaneous written accounts? In other words, do lighting and viewing conditions have implications for historical interpretation." Indeed the context of this passage is intended inquire for the attitude of art historians and critics, but it is also applicable to art conservators when comes to thinking about an artist's intention prior to making a decision towards a certain approach for image reintegration.

Whoever works as an art conservator is always required to justify his or her decision of any conservation treatment he or she chooses to carry out, in particular if there is to be image reintegration treatment. Nevertheless, art conservators should admittedly and unashamedly recognise their justifications, for any image reintegration approach they choose, as ultimately subjective decisions. No matter how experienced and professional the conservator is, how contented the curator is, how

⁵¹ In one of many instances with regard to Picasso's known attitude of altering or completely changing his paintings, an account regarding Picasso's *Seated Harlequin* (oil on canvas, 1901) has the following technical notes stated: "Picasso painted on linen canvas commercially prepared with a white ground. There is considerable evidence of extensive reworking; this includes textured brushstrokes that bear no relation to details in the visible paint film, areas that texturally appear to be losses but are covered by original paint, and the presence of pigmented under-layers throughout... Infrared reflectography confirms that Picasso made numerous changes to the composition, which he developed from a linear underpainting. He shifted the head, shoulders, and proper right arm several times; they were originally positioned several inches to the left of where they are now." (Tinterow and Stein, 2010, p. 49)

satisfied the owner of the art work is or even the artist – if still alive – is. Procedures are frequently challenged and our current practices of image re-integration are unlikely to be an exception.

When proposing a critique to notions like ‘artist’s intention’ and ‘minimal intervention’ we only do so within the context of keeping the integrity of the artwork. There is no doubt that whatever could be done under the term ‘overpainting’ is unethical by all means if threatened that integrity. The practice of overpainting, however, seems to have been carried out towards, at least, the 1970s particularly in private conservation studios. According to Kelly (1972, p. 119) there were still “many commercial restoring firms,” at which it was “common practice to overpaint.” Francis Kelly, who wrote about that in her book; *Art Restoration*, which was first published in 1972, mentions various reasons for overpainting, including the elimination of certain parts of the painting “considered unfashionable or in poor taste according to the period or the individual prejudice of the owner,” or for adding “embellishments... for example, a ship painting might be given flags and rigging never intended by the artist,” (Kelly, 1972, p. 119). Nevertheless, overpainting can be inevitable in various cases. As Nicolaus (1999, p. 261) says: “the legitimate demand that any retouching operation must be restricted to a defective area is often impossible to fulfil.” The discolouration of the original paint layer’s margins adjacent to defective areas is one example on such cases. As in many situations in the conservation of fine art, it is often necessary to reconcile, or compromise, between ideal and reality.

But it is not merely a deception to the eye, it is probably mainly about the state of the cultural conscious of the audience. Purportedly, people are comfortable with viewing statues with broken parts while they are irritated if they look at a painting with lacunae, even if they are relatively small in size. Ruhemann (1968, p. 256) emphasises this remark and, furthermore, provides an explanation:

Some scholars thought that art lovers who did not mind a missing limb in an antique sculpture would soon get used to holes in a picture. But it is not as simple as that: in a statue there is nothing in the place of a missing hand or foot; in a picture, the ‘lacuna’ forms an irregular patch which disrupts the continuity of the whole composition and assumes an active part in it.

Bill Leisher, Head of Conservation, Los Angeles County Museum of Art, gives an insightful thought as he believes “all inpainting is deceptive to some degree. The minute you put color on the canvas even to soften, it's deceptive.” When he then was asked if he thought the term “deceptive inpainting” is intended to be derogatory, he had a thoughtful response: “Some people use that term to describe inpainting which is thought to be so slick that it deceives the viewer into thinking that the entire painted surface is original. At a given distance most inpainting appears original. That's the goal. In this day and age with ultraviolet and all of the equipment we have, in addition to the documentation, inpainting which is invisible is not deceptive in a derogatory sense because you can always find it.” (Black, 1984)

The two different conceptions expressed by Ruhemann and Leister are ably summed up by Salvador Muñoz Viñas in his contemporary theory of conservation. He demonstrated that conservation ethics have been swung between the truth of the artwork and the perception to this artwork by people, i.e. between objectivity and subjectivity. Muñoz Viñas calls for a compromise between what seems as contradicted approaches or what he describes as “adaptive ethics”:

Adaptive ethics acknowledges that a conservation process might be performed for very different reasons and under very different circumstances. Material circumstances (such as the object’s material components or the object’s environment) do indeed play a role. However, subjective factors are usually more relevant, as they lie at the core of the activity. (Muñoz Viñas, 2005, p. 203)

The particular case of image reintegration is often a dispute between the aesthetics surrounding the artwork and the ethics surrounding the conservation of that artwork. It is a matter of finding a safe place between the two notions, between objectivity and subjectivity and between what is feasible and what is not. It would be particularly difficult to find such a safe place in the case of airbrush paintings. It is not just about the smooth finish and the lack of brushwork that pose serious obstacles to seamless imitative reintegration. It is also about the unique characteristic of the airbrushed surface in that it consists of a countless number of extremely tiny dots of paints that are randomly adjacent to each other, superimposed above each other and overlapping each other. Those tiny dots at those varied positions eventually create together the illusion of the continuity of the final image perceived by the naked human eyes at a normal distance from the painting. It is metaphorically a similar type of illusion found in Pointillist paintings by Seurat or Signac, albeit rather made by much larger, individually handmade dots. It is therefore arguably extremely difficult to achieve satisfactory balance between ethics and aesthetics when thinking about interventive image reintegration treatment for airbrush paintings.

4.6 Conclusion

The present chapter is intended as an overview of image reintegration treatments known in the field of the conservation of paintings. Conventional and unconventional approaches of image reintegration were reviewed. Additionally, a critique was given on the terminology pertaining to this subject. A rationale was attempted to reorganise scattered terms into a sensible hierarchy that lie under the term ‘image reintegration’. The latter was rationally suggested as the most appropriate collective term. Furthermore, a discussion on the ongoing discourse of ethics and aesthetics was put to explore it particularly in the context of image reintegration. The next chapter demonstrates the first study undertaken for this research to explore how airbrush paintings are perceived by practitioners in the field of painting conservation. The approach taken for this purpose was via undertaking a survey. The outcomes of this survey are discussed.

Chapter 5: Survey

5.1 Introduction

The uniqueness of the airbrush as an art tool in the context of this research comes from the hypothesis that the subsequent paint film produced by this device might have its own physical characteristics. It is likely that the most important characteristics of airbrushed paint layers are the micro thickness and utter flatness of the paint layer.

Since this is claimed to be a new topic in the field of easel painting conservation, and has not been discussed in the literature reviewed so far, it was essential to undertake a survey to ask practitioners questions relevant to this study. This step constitutes part of the methodology proposed for the research. It mainly aimed to achieve a base of information about airbrush paintings in the current practice of art conservation through an objective of directly exploring the opinions and conceptions of practitioners. A mixed methodology was implemented for this survey in order to achieve measurable quantitative data along with qualitative descriptive information. The research instrument used to carry out this survey was in the form of questionnaires. In this chapter a full account of this step of the study is reported. A full account on the design, technique and the outcome of this survey, as well as evaluation and discussion of the findings are all given in this chapter.

Bowling (1986, p. 1) defines the survey by saying that it is “a systematic means of collecting information directly from people (respondents) often through the use of a questionnaire.” In this case those respondents constitute a form of a primary source on which the researcher is able to reach a preliminary set of outcomes that may, or may not, back his hypothesis. Although it seemed a straightforward step in the first place, the process of the survey encountered a few obstacles. Bell (2005, p. 118) clearly describes this problem: “It is harder to produce a really good questionnaire than might be imagined.” Those issues will be reported in detail in this chapter. Several questions have been encountered relevant to this step of researching and had to be clearly answered:

- What are the objectives of this survey?
- Who would be the right respondents to ask and how might they be located?
- Which questions should be asked?
- How can the best possible wording that would not cause confusion to respondents and eventually misleading answers be achieved?
- What would be the best way for sending questionnaires to respondents?
- How to maintain the best possible conduct of collecting, storing and preserving privacy and confidentiality of respondents.
- How to examine, analyse and interpret the data gathered from completed questionnaires.

These were the main challenging, however not exclusive, issues. Every question created new sub-questions. Thus planning of this survey has been continuously developed to the stage that was thought to be relevant to respondents.

5.2 Objectives of the survey

The preliminary objectives of this study are mainly consisted of establishing two aims; the role of the airbrush in the history of fine art, and the understanding of conservation issues encountered in airbrush paintings within the field of art conservation. Therefore, the survey included two separate questionnaires; one that was intended for art conservators and the other for painters.

As established earlier, there are very few writings about the relationship between the airbrush and fine art paintings. Though there are a few lengthy accounts of such a relationship in which the airbrush seemed to be fiercely debated within art circles over decades until it was effectively and widely adopted by several fine artists in the mid-20th century.

Within the field of conservation, we note that it is not only the type of material that would affect the longevity of a painting; it is also the type of technique. Learner (2007, pp. 3–4) makes this point clear as he argues: “artists throughout the twentieth century experimented with all means of applying the paint to the substrate, such as paint rollers, spray guns, splashing and pouring – and this is another factor that can significantly affect the characteristics of the final paint film and its subsequent reaction to ageing and treatment”. That said, it is surprising that there seems to be no source, so far known, to have investigated the implications that the airbrushing techniques might have upon the condition of a painting.

It is important to note that the two aims of the study are not contextually separate. Tracking the conjoint history of modern fine art and the airbrush is important to determine the early attempts of the employment of airbrushing techniques in easel paintings. Following such a determination, the gradual ascending acceptance of the airbrushing techniques amongst fine artists can be tracked. The best example of the use of complex airbrushing techniques would be expected in the works of a number of the Photorealists. Gathering such information would help eventually in determining whether there is a possibility that the method of applying paint through airbrushing will yet have an unknown impact on the condition of airbrush paintings. Finally it is intended that this research would lead to an evaluation of conservation treatments according to the findings.

The survey consisted of two questionnaires. One was aimed at art conservators and the other was aimed at fine artists who should have some experience in airbrush painting. The goals of the questionnaire aimed at art conservators were:

- To assess the extent of current knowledge amongst art conservators in terms of conservation problems presented by airbrush paintings.
- To demonstrate the scale of the problem of airbrush paintings requiring treatment compared to that of paintings of other techniques
- To determine the level of experience that art conservators might have with airbrush paintings.
- To identify common conservation problems that might be significantly related to the use of airbrushing techniques.
- To gather further information regarding structural characteristics specific to airbrush paintings.
- To obtain an understanding of the current conservation treatment methods commonly carried out by art conservators for problems related to the technique in airbrush paintings.

The goals of the questionnaire aimed at fine artists were:

- To recognise the extent of acceptance amongst fine artists regarding the use of the airbrush in fine art painting.
- To gather information on the common airbrushing techniques employed by artists.
- To gather information on the common airbrushing materials employed by artists.
- To identify the main reasons for artists to employ, or not to employ, airbrushing.
- To note the extent of the awareness of the possible health impact of airbrushing.

5.3 Strategy of the survey

In order to achieve the objectives sought from this survey, it was important to set a strategic plan. The survey depended on a mixed methods approach that consisted of both quantitative and qualitative data. The rationale behind this approach was to collect not only figures but also concepts and ideas from respondents. In other words, it was important to not only know, for example, an estimated percentage of the conservators who have had experience in treating airbrush paintings, but also to get closer to their opinion regarding, for example, the common problems they found which were exclusively relevant to such works of art. The mixed methods approach in this context was expected to allow the researcher to achieve a more comprehensive analysis of the research problem under investigation.

The questionnaires were formatted according to models and guidance from the relevant literatures, including Babbie (1990), Oppenheim (2000), Bell (2005) and Brace (2008). Certain criteria have been set up in order to establish reliability and validity of the research instrument. This was particularly achieved through deciding to build the questionnaires in an electronic format using one of the online survey providers. This method provided advantages, such as:

- The ability to restrict each respondent to only one response.
- The ability of providing proper guidance for the respondents throughout the questionnaire, so they only answer questions relevant to them.
- Better control to achieve anonymity and confidentiality of the respondents.

Other benefits; examples:

- Cost effective.
- Better circulation.
- Better ability of the following-up of the participants, e.g. for further queries.
- The ease of data exportation for analysis and interpretation.

5.4 Designing the questionnaire

There are many web survey tools that can be found online. A number of them have been investigated and tried in order to compare them. The one eventually chosen to be the platform for conducting this survey was SoGoSurvey.com. This online survey platform offers a variety of tools which were important in the design of the questionnaires. For instance, it provides the researcher the ability to create complex skip-logic and branching required to lead respondents to their relevant questions according to their responses. It also offers a user-friendly interface either for the builder of the questionnaire or the respondents.

Both questionnaires, aimed at both conservators and artists, have been principally designed to have ‘routing instructions’ for those who do not have practical experience with the airbrush paintings. ‘Routing instructions’ here mean that such respondents should be guided away from the questions irrelevant to them depending on their answers. In other words, they should have to be only guided through the questions aimed at anyone within the research sample, who has either dealt with airbrush paintings or not. In an electronic questionnaire, routing can be created without having to put respondents into the inconvenience of following complicated instructions. Routing each group of respondents away from questions irrelevant to them has to be done through a ‘filter question’ (Figure 57). “A filter question is used to exclude some respondents from a particular question sequence if

those questions are irrelevant to them” (Oppenheim, 2000, p. 111). Examples of the questions in common are those regarding age group, nationality and level of education.

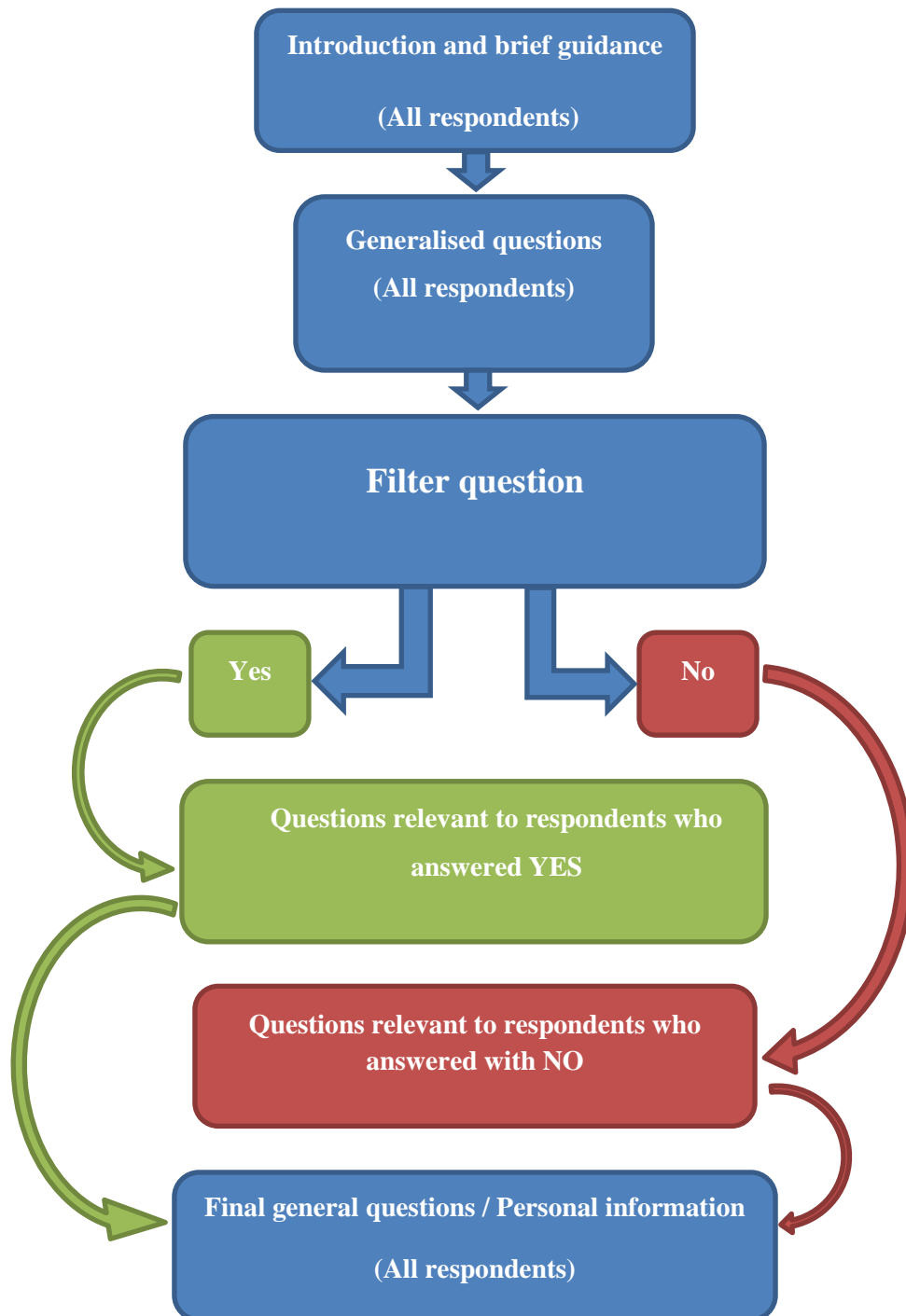

Figure 57: a diagram of the design and sequence of the survey aimed at easel painting conservators as a part of the research in the form of a questionnaire

Both questionnaires, aimed at conservators of easel paintings and fine artists, are generally similar in the design. Each questionnaire started with an introduction to the subject of the research. In the

introduction page there was also a brief guidance to assist the respondent to determine certain technicalities, such as the approximate time required to complete the questionnaire. In the following section, we discuss in further detail the design and strategy of the questionnaire that was aimed at easel paintings' conservators.

5.5 The questionnaire aimed at conservators of easel paintings

As illustrated in (Figure 57), the questionnaire consists of a sequence of questions distributed amongst three sets. The first set of questions are generalised to apply to any easel painting conservator. This section includes questions about basic socio-demographic information, such as gender, age group, and residency. It also includes questions related to the expertise of the respondents, such as the level of experience and the types of easel paintings they treat. The same section comprises asking for the respondent's opinion about certain debatable issues relevant to this study, such as whether paintings executed with the airbrush are considered fine art. The last question in this section is the filter question through which the respondent is directed away from her or his irrelevant next set of questions. The filter question is: "have you ever, throughout your career, encountered airbrush easel paintings that had to undergo any type of conservation treatment?" and it could only be answered with either Yes or No.

The second set of questions is divided into two subsections depending on the answer on the filter question. Those who answered with 'No' on the filter question were directed to only one question exclusively relevant to them before moving to the third section which, again, applies to both groups of respondents. They have been asked about the reason as to why they did not carry out conservation treatment before on airbrush paintings. On the other hand, respondents, who answered 'Yes' on the filter question, were required to answer more in-depth questions with regard to the subject of this research. The questions in this subsection inquired into the participant conservators about two principal matters;

- What are, if any, the differences in super-strata in airbrush easel paintings comparing to traditional paintings? And,
- Were there any conservation problems found in the super-strata of airbrush paintings, and what are they?

The third, and final, set of questions was aimed again at all respondents participating in this questionnaire. They have been asked for an optional statement if they have had further information or comments that might add to the research. Finally, they have been asked to add their contact details if they agreed to be contacted by the researcher if he wishes to require more information in the future.

The types of questions in this questionnaire are mostly closed. There are a number of open-ended questions, permitting five respondents with the opportunity to freely describe their opinion regarding certain issues. Brace (2008, p. 46) defines an open-ended question as “one where the range of possible answers are not suggested in the question and which respondents are expected to answer in their own words.” The answers obtained from this question type are verbatim and cannot be properly pre-coded. However, and even if they cannot provide coherent statistical data, they offer more insight towards respondents experiences with the subject of research. A benefit of this question type is that it helps the researcher to discover aspects through the answers that might not have been predictable and could not be thought of to be included in closed questions.

A closed question, on the other hand, is one that suggests a set of answers from which respondents are expected to choose one or multiple answers, pre-coded for statistical purposes. In this questionnaire, closed questions offered to respondents both the choice of multiple answers in certain questions (multiple-choice questions) and the choice of one answer only in others (dichotomous questions). For example, the respondent was offered to choose more than one answer when asked about the materials he or she encountered as a conservator, while a question about age group entitled respondents for only one answer to choose. Answering options under a number of closed questions are attitudinal and structured in the form of the Likert rating scale by which respondents can choose one answer within a five-point scale:

- Strongly agree
- Agree
- Not sure
- Disagree
- Strongly disagree

Most of the questions have been assigned as ‘mandatory’. This means respondents must respond to those questions with one, or more, of the answers provided. This method has been intended to encourage respondents not to ignore or miss responses that could be important to the research. However, open-ended questions, besides few others, have been left optional trying to prevent deterring participants away from completing the questionnaire.

It was highly important to make sure that each participant was able to complete her or his copy of the questionnaire only once. In order to ensure the reliability of the results, more than one response from any individual respondent had to be strictly prevented to avoid what is known as ‘ballot box stuffing’. Therefore, a unique URL (uniform resource locator) to the questionnaire has been sent to each participant. The web-based survey platform provided the proper tools to fulfil this requirement. Another method is to add a public link to a website or an email group and rely on volunteer visitors.

The latter method, however, would cause concerns about the quality and quantity of responses, and was therefore avoided (Vaus, 2013).

5.6 The research sample

Upon reaching the final steps of this questionnaire, it was essential to start to prepare a list of easel painting conservators to whom the questionnaire would be sent. This task was not at all a simple task for several reasons. For instance, the researcher has had to find sources which contain information about conservation practitioners, then to exclude all but those who state that they are specialised in the conservation of easel paintings. It was also essential to find the email addresses of the prospective participants, within the information gathered from those sources. The email addresses then had to be extracted and listed separately to be added afterwards to the email list of the web-based survey tool.

The researcher relied on the databases of art conservators available online. The two resources that were found to be the most useful to gain contact information were: the American Institute for Conservation of Historic and Artistic Works (AIC) official website, and ConsDir which is a part of the Conservation OnLine (CoOL) website, another online resource operated by the AIC. Both resources contain large and yet a classified database of conservation practitioners. The extracted data was refined to remove duplicates and to ensure it exclusively includes those who declared experience in the conservation of paintings.

The questionnaire aimed at art conservators was sent to two different groups, depending on the availability of their email addresses, between 13th of February to 2nd of April 2013. The total number of prospective participants to whom the questionnaire was sent is 1573. The questionnaire was eventually delivered to 1193 prospective participants. This means 380 email addresses were invalid. Sixty seven respondents participated in the survey. Five of them have not completed the questionnaire. Completed responses number was sixty two. Out of the latter, thirty six conservators said they have a certain amount of experience in the conservation treatment of paintings executed with the airbrush.

5.7 The demographic profile of respondents

(Please note that all tables and charts mentioned in this chapter are listed in Appendix A.1.2)

This section provides an overview of the demographic and social characteristics of the research sample, such as; gender, age group, and place of residence. This information is illustrated in the charts and tables listed in Appendix A.1.2.1.

The tables (Table 9 to Table 13) and charts (Figure 98 to Figure 102) demonstrate demographic characteristics of the research sample of the conservators of easel paintings. Tables from (Table 9) to (Table 12) demonstrate these characteristics separately according to; gender, age group, highest level of education and country of residence. This information is also visually illustrated using graphic pie charts and bar charts. Out of 62 respondents there are 39 female, 21 male and 2 preferred not to answer. 60 years old or over was the age group with the largest number of 12 respondents followed by 45-49 and 40-44 age groups that were equal at 11 respondents. The age group with the least number was 25-29 with only 3 respondents. We can see that the highest level of education most of art conservators in this sample achieved is Master's degree with 48 out of 62 respondents. With regard to the country of residence, the USA has the largest proportion of this sample with 33.87% followed by the UK 16.13%, Australia 9.68%, Canada 6.45%, and Germany 6.45% respectively. (Table 13), illustrated by (Figure 102), compares the proportions of gender against age groups. It can be seen that the female respondents form the largest proportion in more than one age group, particularly at 35-39 and 45-49 categories. The demographic statistics show that the majority of the respondents are from the US and the UK with much less responses from Australia and other European countries. This might indicate more interest in the subject of the survey in those two countries, although other factors might have their impact over the decision to participate or not in the survey, such as the language. On the other hand there is a better distribution of respondents according to their age groups, which is helpful in gaining information based on varied periods of experience in art conservation, particularly backed up by good educational backgrounds indicated by the high proportion of respondents who hold MA degrees. Further information on the distribution of the degrees of experience was acquired through the career-related questions.

5.8 Career-related questions

Respondents have been asked general questions with regard to their career. The questions focused on their type and level of experience. 53.23% of the respondents state that they work as private conservators, while those who work for a museum or a gallery were 22.58%. 24.19% of the respondents chose 'other' and provided varied answers. The vast majority of respondents (82.26%) state that they have experience in both traditional and contemporary paintings. Only 11.29% are experienced in traditional paintings, and 6.45% are experienced in contemporary paintings. Most of the respondents have 10 years or more of experience in the field of fine art conservation. They constitute 80.65% of the sample. (Figure 103)

Respondents have also been asked about their annual incomes with an assumption that the more the income means a higher level of experience. Knowing that answering such a question can be inconvenient for some respondents, a 'prefer not to say' option has been made available for them to

choose. 53.23% of the sample chose not to answer this question. However, it is obvious that a sum of 22.58% of the sample receives above the average of annual incomes, from \$80,000 and up to more than \$101,000. This supports the indication that, as shown in (Figure 103), a high percentage of the respondents in this sample have a long term of professional experience in the field of conservation.

Respondents have been additionally asked to select one or more of different types of painting supports on which they carried out conservation treatments. All of the respondents stated that they have experience in canvas (natural fabric) and 98.39% of them stated that they have experience in wooden panels (Figure 104).

5.9 Attitudinal questions

In this set of questions the respondents have been asked about their opinion in certain issues with regard to airbrush painting. The issues covered by this set of questions are: the extent of acceptance of the airbrush as a tool to be used in fine art, the extent of the effect of the technique used in paint application on the condition of paintings, and the extent of the knowledge of art conservators regarding the conservation of paintings executed with airbrushing. This set of questions falls under a type of attitudinal rating scales, more specifically Likert scale. (Brace, 2008, p. 73) In this type of questions, respondents are asked to express their opinions via indicating a degree of agreement or disagreement with statements raised by the researcher. Respondents have been required to choose one option from the following answers: (Strongly agree – Agree – Not sure – Disagree – Strongly disagree). The group of questions was as follows:

1. In your opinion, the airbrush is acceptable as an art tool for FINE ART painting?

A high percentage of the respondents indicated agreement with this this statement. 48.39% answered with 'agree' and 27.42% chose 'strongly agree'. 20.97% of the respondents showed uncertainty via answering with 'not sure. On the other hand, a very small proportion indicated disagreement with this statement, with 1.61% for 'disagree' and equally 1.61% for 'strongly disagree' (Figure 105). Their answers show their own impressions about the use of the airbrush as a fine art tool.

2. In general, art historians and critics have not considered airbrush painting to be fine art?

The respondents here are required to show if they believe or not that the airbrush is generally accepted in art circles as a fine art tool. However, it was expected that respondents might have provided answers based upon their own point of view to this issue. In other words, although it should be

considered that the statement here deals with what is supposed to be answered with facts, respondents were likely to have depended on their personal opinions to indicate either degrees of agreement or disagreement. A high proportion of uncertainty is represented by 45.16% of all respondents. Interestingly, the total proportion of disagreement indicated by respondents is higher than that of those who indicated agreement. This is represented by a total of 32.26% of disagreement (27.42% disagree plus 4.84% strongly disagree) against 22.58% for 'agree' (Figure 106). This is interesting because there is obviously a number of respondents who personally believe that the airbrush is suitable as a tool for fine art paintings. However, at the same time, they cast doubts over the extent of admittance by the wider fine art circles, e.g. by art critics.

3. The condition of a painting can also be affected by the techniques of paint application used by artists, and not only the materials employed.

The vast majority of the respondents agree with this statement with 75.81% for 'strongly agree' and 20.97% for 'agree' (Figure 107).

4. Art conservators already have knowledge about problems that might be directly related to the airbrushing application in airbrush paintings.

In this statement 46.77% of the respondents showed uncertainty about the issue raised. It is almost half of the respondents who are not sure whether or not art conservators have knowledge about problems that might be directly related to paintings executed with the airbrush. Moreover, 17.74% believe that art conservators do not have such knowledge. On the other hand, 27.42% indicated their agreement on the issue raised in the statement, while a much smaller percentage 8.06% indicated definite agreement (Figure 108).

5. Art conservators currently lack knowledge regarding problems that might be directly related to the airbrushing application in airbrush paintings.

The issue raised in statement number 4 was repeated again here in this statement, number 5. However, this time respondents have been asked if they think art conservators lack, rather than have, such knowledge. This repetition of the issue, but with different phrasing, was meant to be a way of confirmation on the outcomes of the statements 4 and 5. We can see that the outcomes here support those from statement number 4. The highest percentage of the respondents still 'unsure' about the issue. Furthermore, those who generally and strongly agree that art conservators lack knowledge regarding problems of airbrush paintings form 45.16% altogether against only 12.91% who think otherwise (Figure 109).

6. If you have an airbrush painting that needs image reintegration (e.g. filling, inpainting, etc.), then you have a clear idea of the conservation treatment you may safely use.

This is the last statement in this set of attitudinal scale questions. The statement requires respondents to choose an answer depending on their own experience, if any, with the conservation treatment of airbrush paintings. The percentage of those who preferred to answer with ‘not sure’ is 37.10%, 16.13% is the percentage of respondents who answered with ‘disagree’, and 4.84% is of those who chose ‘strongly disagree’. These three proportions form altogether 58.07% of the whole sample of research. This means that more than half of the respondents have more or less of uncertainty about a clear idea of treating an airbrush painting if it requires image reintegration treatment. On the other hand, 41.93% indicated an extent of agreement; 33.87% agree and 8.06% strongly agree (Figure 110).

5.10 Branching question

The next question is direct and specific for those who actually dealt with airbrush paintings. It was intended to ‘branch’ the respondents into two groups. The first group combines those who indicated that they have practical experience in conservation treatment of paintings executed with the airbrush, while the second group combines the respondents who have had no such experience. The first group has been then assigned a set of questions directly related to their experience. The respondents in the second group have been directed away from the questions irrelevant to them and led into the end of the questionnaire. The table (Table 14) contains the exact wording of the question and a distribution of the respondents according to their answers. This table is followed by a chart (Figure 111) which visually illustrates the data.

In (Table 14) we can see that 36 respondents out of 62 (58.06%) indicated they have encountered airbrush easel paintings that had to undergo any type of conservation treatment. On the other hand 26 respondents out of 62 (41.94%) indicated they have had no such direct experience. Accordingly, the 36 respondents who answered with; ‘yes’ on this branching question have been directed to a final set of questions and statements prepared exclusively for them.

5.11 Questions only related to respondents with direct experience in airbrush easel paintings:

In (Table 15) there are attitudinal types of questions which require the respondents to choose one answer within a scale from ‘strongly agree’ to ‘strongly disagree’. Please note that the ratios are based on the number of 36 respondents who indicated their direct experience with airbrush easel paintings. (Figure 112) illustrates the proportions of the same ratios shown in (Table 15) in the form of a bar

graph. We can see that the majority of the responses indicate an agreement that there can be conservation problems in airbrush paintings, different from those in the paintings executed with other paint application types. Out of 36 respondents there is only one who disagrees and another respondent who strongly disagrees, while 6 respondents were not sure if such a difference exists.

The table (Table 16), illustrated in (Figure 113), shows responses to a question about the procedures often required for the conservation treatment of airbrush paintings. It is important to note that this is a multiple-choice question, therefore each answer can be chosen by up to 100% of the 36 respondents. The most chosen answers are: cleaning (72.22%) and image reintegration (66.67%) followed by preventive conservation (58.33%). There are 44.44% who believe that there are no significant procedures required in airbrush paintings than those required in other types of paintings.

In (Table 17) the respondents were asked to indicate how thick the ground layer generally is in airbrush paintings compared to other types of paintings. 13 (36.11%) out of 36 respondents believe that there is no difference, while 10 (27.78%) out of 36 respondents believe that the thickness of the ground layer in airbrush paintings is generally lesser. 25% of the 36 participants responded with the answer 'other'. They provided different statements to justify their choice, and these statements can be generally summarised as follows: "all paintings vary". See also the chart in (Figure 114).

In (Table 18) participants were asked to provide their opinion about the thickness of the paint film in airbrush paintings compared to other types of paintings. 29 out of 36 (80.56%) respondents indicated that they believe it is 'lesser'. On the other hand 6 respondents (16.67%) chose the answer 'Other' and provided statement to elaborate on this answer. Their statements vary as three believe that "all paintings are different", while the other three statements are: "probably less thick than paint-brushed," "there really is no paint 'film' most of the time," and "it is less the thickness as the texture that presents problems." See also the chart in (Figure 115).

In (Table 19) the participants were asked about the frequency of the existence of deterioration problems they encountered in the paint film in airbrush paintings. The highest percentage of responses went to 'sometimes' at 50%, which represents 18 out of 36 respondents. In the second rank was the answer 'rarely' at 30.56% which represents 11 respondents. The answers 'often' and 'never' gained 11.11% and 8.33%, respectively. See also the chart in (Figure 116).

In (Table 20) the 36 participants have been asked about the paint medium they found, and said that it was dominantly used in the airbrush paintings they encountered. 27 respondents (75%) indicated that they found that synthetic media, such as acrylics, were dominant in airbrush paintings, while a much less percentage of respondents (11.11%) indicated that natural media were dominantly employed. 5

respondents (13.89%) chose the answer 'other' and elaborated by stating other types of media, such as alkyds and vinyl. See also chart in (Figure 117).

The question in (Table 21) is the final in this group of closed-questions dedicated for the 36 participants who stated that they have direct experience in the conservation of airbrush paintings. Those participants have been asked about the frequency of the existence of varnish layer in airbrush paintings. Responses are almost equally distributed among three answers: sometimes, rarely and never with 36.11%, 33.33% and 27.78%, respectively. One respondent only (2.78%) chose 'often' as an answer. See also chart in (Figure 118)

5.12 Open-ended questions

These types of questions depend on free-responses from participants. Such responses are recorded verbatim. One advantage of this type of survey questions is that it offers a chance for the participants, for more spontaneity and expressiveness because they are not confined within certain given answers to choose from, as in the case of closed questions. Open-ended questions are also known as 'free-response' or 'unstructured' questions and they can be used in a survey for several reasons depending on the purpose of the research (Brace, 2008, p. 42). Responses to open-ended questions are known to be more difficult to be analysed than those in closed questions which have a prompt list of possible answers that can be pre-coded for data analysis. However, spontaneous answers given by respondents to open-ended questions can be categorised and coded accordingly to achieve quantitative data (Oppenheim, 2000, p. 113). Additionally, responses to open-ended questions offer in-depth qualitative information which can be valuable to the researcher.

This questionnaire aimed at conservators contained only three open-ended questions. One of these questions was general and aimed at the 62 respondents participated in this questionnaire, and the other two questions were exclusively specified for the 36 respondents who indicated earlier in the questionnaire that they have had direct experience in the conservation treatment of airbrush paintings. Care has been taken not to put too many open-ended questions. Moreover, all of these questions have been made optional to the participants, so they were able to skip answering them if they did not want to. This was important to avoid losing respondents who might be reluctant to provide lengthy answers and could have renounced the completion of the questionnaire.

The three open-ended questions were as follows:

- i. Please provide further details about problem(s) you have found specific to airbrush paintings.**

This question was specifically aimed at participants who indicated direct experience in airbrush paintings. Despite the responses varied, commonly occurring themes were located and coded by the researcher and grouped to establish “code frames” (Brace, 2008, p. 43). Kumar (2002, p. 61) advises recording the exact words given by respondents in open-ended questions without any attempt of interpretation by the researcher. However, this could not be practical in this questionnaire because sometimes terms in the field of conservation are similar in meaning. So certain different terms were grouped together under one theme. For example, ‘retouching’ and ‘in-painting’ were grouped in the code frame: image reintegration problems. Transforming qualitative data to eventually quantitative values was performed using Microsoft Excel.

The pie chart in (Figure 119) shows the proportions of quantitative results extracted from the verbatim responses of the above open-ended question. The responses were grouped according to the occurring theme under three categories: image reintegration problems, cleaning problems and structural treatment problems. Image reintegration problems were found to form a proportion of 60% of the total treatment problems addressed by the respondents. Cleaning problems comes secondly at 32% while structural treatment problems consisted only 8% and of the responses. It is important to clarify that each response could have one or more of the occurring themes. Accordingly, these percentages represent the number of occurring themes proportional to the total number the responses to this specific question and not the respondents.

ii. Please specify which deterioration type(s) in the paint film you encountered.

This question was specifically aimed at participants who indicated direct experience in airbrush paintings. Deterioration in paint surface forms about 27% of the responses to this question.

iii. It will be very helpful for the researcher if you had any comments or thoughts you kindly would like to share. Please feel free to elaborate here on any of the responses you have given, or add any comment you think can benefit the research.

This question was aimed at all participants in this questionnaire. All responses received for this question and the abovementioned open-ended questions are listed verbatim in (Table 22)

5.13 Verbatim responses to the open-ended questions

(Table 22) shows all verbatim responses received for the three open-ended questions of this questionnaire; all the responses presented are anonymous and copied as originally received. It is important to point out that the empty spaces in the table represent no responses; this is due the fact that open-ended questions were left optional for the respondents.

5.14 The questionnaire aimed at fine artists who are used airbrush in their work

This questionnaire followed the structure done in the questionnaire aimed at the art conservator. This second questionnaire is titled “Airbrush Easel Painting in the Context of Fine Art”. It was sent to 86 potential respondents to which 85 were delivered. Unfortunately, and despite repetitive gentle reminders, Only 9 responses were eventually received. The researcher decided that this number of responses would not make enough meaningful data that could be presented in this chapter. However, the verbatim answers provided by the respondent fine artists provide interesting insight of their way of thinking about the airbrush and its role in their art. A table of verbatim answers is provided in Appendix A.1.4.

(Please note that all tables and charts mentioned in this chapter are listed in Appendix A.1.2)

5.15 Conclusion

Two different questionnaires were used to undertake a survey among paintings conservators and fine artists. Unfortunately responses from artists were too few to provide sensible data. On the other hand, responses from paintings conservators were deemed representative enough to analyse and study. The analysis of the data from the responses of this questionnaire provided insightful outcomes on the status of airbrush paintings in the field of art conservation. The following points summarises the important outcomes of this survey:

- About 76% of the respondents accept the use of the airbrush for fine art painting.
- About 97% of the respondents agree that the painting can also be affected by the paint application technique used by the artist.
- Only about 35% of the respondents agree that art conservators are knowledgeable about problems that might be directly related to airbrush paintings. This is particularly interesting, taking into account that 88.71% of the respondents asserted that they have at least eight years of experience as practitioners.
- Only 42% of the respondents asserted that they have a clear idea how to treat airbrush paintings which require image reintegration. This is despite the fact that 58% of them said that they have had direct experience with airbrush paintings throughout their careers.
- Among those who asserted that they have had direct experience with airbrush paintings, about 78% agreed that airbrush paintings can particularly show unusual problems.

- About 67% of the latter respondents said that airbrush paintings often require image reintegration.
- About 81% of the latter respondents agree that the thickness of the paint film in airbrush paintings is smaller than that of other types of paintings.
- 75% of the latter respondents find synthetic paints the most used in airbrush paintings.
- Most of the latter respondents encounter few to none airbrush paintings with varnish layer while only about 3% of them say they often encounter such cases.
- Finally, the quantitative analysis of verbatim responses confirms the previous assertion that image reintegration is particularly problematic.

The previous points indicate two important conclusions: First is the lack of knowledge about airbrush paintings from the perspective of art conservation. Second is the need to look more deeply into the problems particularly related to the nature of sprayed paint films in those paintings and the type of subsequent image reintegration treatments they could require. The second stage of this research is presented in the next chapter. It is intended to explore the effect of light ageing on airbrushed acrylic paint films on mock-up samples through a series of different approaches.

Chapter 6 – Chemical Analysis, Light Ageing Test and SEM

Imaging of Acrylic Paint Samples: Experimental and Results

6.1 Introduction: Synthetic Paints in the Context of Art Conservation

There is a body of conservation literature published which focuses on ways to understand the behaviour of synthetic paints in modern easel paintings. Similarly, different approaches were explored to deal with specific issues related to specific types of synthetic paints. Since acrylic paints are the main constituents of a relatively large body of easel paintings of the 20th Century, a significant amount of investigation took place towards understanding and treating them. Acrylic paintings raise particular conservation concerns with regard to the paint film.

Some of those concerns are raised regarding the image reintegration of acrylic paintings. Conservation ethics, of course, require practitioners to choose media and materials for their conservation treatments that could be later reversible without affecting the integrity of the original artwork. Therefore, it is particularly difficult to choose retouching media suitable for acrylic paintings. Among several important aspects of literature published on this subject, Perry (2000, pp. 19–22) provided an outlook on the image reintegration of damaged modern art. An overview of the research into retouching resins was given by Bucklow (2010, pp. 61–65). Investigation into the use of particular media was done by several researchers including Koneczny (2010, pp. 66–73), Lowry (2010, pp. 87–91) and Dunkerton (2010, pp. 92–102).

The present chapter demonstrates the chemical analysis of three different commercially available acrylic paints plus acrylic white gesso using FTIR and Py-GC-MS methods. The three paints represent the three primary colours; cyan, magenta and yellow that are commonly used by prominent artists who used the airbrush in their paintings, such as Chuck Close. Instead of mixing the paints on a palette, airbrush artists commonly create their desired hues via the overlap of those three colours. In the meantime, the white ground of the painting is effectively used to create the lighter areas. This is similar to the CMY colour system commonly used in colour print production.

The analysis was performed in order to identify and confirm the components of the paint. The combination of the FTIR and Py-GC-MS analytical techniques is an established procedure used to provide information about organic pigments and synthetic media with confidence. This was a preliminary step prior to the exposure of the paints' samples and the assessment of their behaviour under accelerated light ageing. The procedure and results of the accelerated light ageing tests performed for this research is also demonstrated in the present chapter.

The accelerated light ageing tests were followed by the imaging and examination of the topographical features of the paint surface of the samples by a scanning electron microscope (SEM). The main aim of this procedure is to investigate whether any physical change occurred to the surfaces of the aged samples by comparing their SEM images to those of non-aged samples. More details on this procedure are presented in this chapter.

6.2 Overview of the analytical techniques used in this study

According to Learner (2005, p. Preface) Fourier Transform Infrared Spectroscopy (FTIR) and Pyrolysis Gas Chromatography-Mass Spectrometry (Py-GC-MS) are two of three analytical methods⁵² that are “the most useful and widely employed analytical methods for the analysis of modern paints.” FTIR is a long established standard analytical method in conservation science used to analyse a wide variety of the materials found in the works of art (Derrick, Stulik and Landry, 1999, p. 3). The FTIR method identifies “the functional groups present in a molecule and the spectrum of an unknown can then be compared to a spectrum in a reference library.” (Lomax, Schilling and Learner, 2007, p. 105) The frequency range from 4000 to 500 cm^{-1} is the mid-IR region in which the FTIR system is capable of the identification of “molecules bonds in a material by their resonance frequencies.” (Thomas Learner, 2005, p. 34) One of the earliest uses of Py-GC in paintings was by Breek and Froentj (1975) to identify certain synthetic resins. De Witte and Terfve (1982) used Py-GC-MS for the analysis of a number of synthetic artists materials including acrylic paints. The use of Py-GC-MS for the analysis and characterisation of organic paints was extensively investigated from 1990 by Sonoda and Rioux (1990), (1993) and by Sonoda (1999). GC and GC-MS were originally used in conservation science to identify traditional paint materials, such as; resins, oils and egg tempera. Because of the high molecular weights in the synthetic materials present in modern paints, the latter systems have not been applicable. The addition of heat in the absence of oxygen (pyrolysis) to a GC or GC-MS system proved successful for the identification of many of the modern paints. Pyrolysis is capable of breaking down those “polymeric materials into volatile fragments... and the fragments can be separated and identified by GC or GC-MS.” (Thomas Learner, 2005, p. 30)

⁵² The third analytical method mentioned by Learner is direct temperature-resolved mass spectrometry (DTMS)

6.3 Investigation of acrylic gesso and three acrylic paints

6.3.1 Samples investigated in this report:

As listed in (Table 3) four samples were collected for Py-GC-MS and FTIR chemical analysis: one sample is from white ‘Acrylic gesso’ of Raphael[®] brand, and the other three ‘Acrylic’ paints⁵³ are Primary Cyan, Primary Magenta and Primary Yellow. The three paints were all of Golden Artist Colors[®] brand. Those are the names of the paints as given by the company. According to the company’s technical literature, the main pigments in Primary Cyan are Copper Phthalocyanine and Titanium Dioxide Rutile⁵⁴, the main pigment in Primary Magenta is Quinacridone⁵⁵ and the main pigment in Primary Yellow is Arylide Yellow and Titanium Dioxide Rutile⁵⁶. Each of the four samples was placed directly, from its original container, onto a glass slide marked with the name of the sample. The four glass slides were immediately put in a closed clean glass container to minimise the possibility of collecting contaminants by the drying samples. After they were completely dried out, the samples were then submitted for chemical analysis using Py-GC-MS and FTIR methods.

Table 3: List of samples

Sample number	Description of sample	Analytical methods used	comments
1	Raphael Co. ‘Acrylic gesso’, white	FTIR, Py-GC-MS	Dried film
2	Golden Company primary yellow	FTIR, Py-GC-MS	Dried film
3	Golden Company primary magenta	FTIR, Py-GC-MS	Dried film
4	Golden Company primary cyan	FTIR, Py-GC-MS	Dried film

⁵³ Prominent fine artists who have had a long established experience with airbrushing techniques, such as Chuck Close and Don Eddy, always chose very limited set of colours – mostly up to three - for their paintings executed with airbrush.

⁵⁴ www.goldenpaints.com/products/colors/heavy-body/primary-cyan

⁵⁵ www.goldenpaints.com/products/colors/heavy-body/primary-magenta

⁵⁶ www.goldenpaints.com/products/colors/heavy-body/primary-yellow

6.3.2 Experimental

6.3.2.1 *Fourier Transform Infra-red (FTIR) Analysis*

Each sample of paint shown in (Table 3) was placed onto the diamond window of a Bruker Opus Fourier transform Infra-red spectrometer. The sample was pressed directly on the diamond window, using enough material to cover the central area (if possible), i.e. the centre 0.5 mm portion of a line of approximately 0.2 mm width. The spectrum was recorded in the range from 4000 to 380 cm^{-1} , using 24 scans at 4 cm^{-1} resolution. The background scan was automatically subtracted and the scans averaged to produce a spectrum.

6.3.2.2 *Pyrolysis GC-MS analysis*

Each sample was placed on the platinum ribbon of a Pyrolla 2000 pyrolyser and pyrolysed at 600°C for two seconds. This procedure decomposes polymers present in the paint.

The components of decomposition were then passed directly to the GC column in a stream of helium and analysed by GC-MS. The GC-MS instrument used was a Thermo Focus GC fitted with a DSQ II mass detector. The column used was a Thermo TR-5 30m column and the temperature of the column was raised from 40°C to 290°C at a rate of 8°C per minute within the run. Detection was started after 0.1 minutes.

6.3.3 Results and Discussion

6.3.3.1 *Investigation of the sample 1, Raphael 'Acrylic gesso', white*

6.3.3.1.1 FTIR Analysis

The spectrum (Figure 58) is typical of an acrylic/styrene copolymer. Hydrocarbon moieties are indicated by: (C-H stretch) peaks at 2955, 2928, 2872, and indicating ester groups: ester carbonyl (C=O stretch) at 1727, (C-O stretch) at 1250 (shoulder on 1409) 1159, 1114 and 1061 cm^{-1} and indicating styrene: aromatic C-H deformation at 756 and 697 cm^{-1} . There are also peaks for chalk (calcite) (1409, 872 and 711 cm^{-1}) (Figure 59).

6.3.3.1.2 PY-GC-MS

Peaks were found for styrene and butyl acrylate. There was also a trace of methylstyrene (Figure 60) and (Figure 61). Hence, the binder in this paint appears to be a butyl acrylate/ styrene copolymer, with styrene as the major component. The methyl styrene may be an impurity in the styrene or may have been deliberately added to modify the co-polymer

6.3.3.2 Investigation of sample 2, Golden Company, Primary yellow

6.3.3.2.1 FTIR Analysis

The spectrum (Figure 62) is typical of an acrylate /methacrylate copolymer type acrylic paint. (peaks at 2954, 2873(C-H peaks), 1726 (ester carbonyl), 1234,1159, 1137,1066 (C-O stretch), and 752cm⁻¹) (Figure 63).

The peaks at: 1503, 1459, 1357, 1279, 958, 917 and 752 may be due to the pigment; Pigment Yellow 17 is given for comparison (Figure 64)

6.3.3.2.2 Py-GC-MS Analysis

Three acrylic monomers were recognised in the pyrogram (Figure 65): methyl methacrylate, butyl acrylate and a trace of butyl methacrylate. Hence the binder in this paint is probably a methyl methacrylate/ butyl acrylate copolymer, the trace of butyl methacrylate could be either an impurity or was formed by transesterification during the pyrolysis. Interestingly some peaks were also found which are derived from the pigment: i.e. peaks for 2-chloroaniline, 2-methoxybenzenamine and 2-methoxyphenyl isocyanate (Figure 66). Pigment Yellow 17 gives these products on pyrolysis (Russell *et al.*, 2011) and hence this disazopigment, PY17 is the probable pigment in this paint.

6.3.3.3 Investigation of sample 3, Golden Company, Primary Magenta

6.3.3.3.1 FTIR Analysis

The spectrum (Figure 67) is typical of an acrylate /methacrylate copolymer type acrylic paint. (peaks at 2956, 2874 (C-H stretch), 1726 (ester carbonyl), 1235,1159, 1137,1066 (C-O stretch), and 752cm⁻¹) (Figure 63).

The peaks at 1586, 1470, 1449, 1342, 989, 960,895, 873, 849, 813 may be due to the pigment, possibly the red crystal form of PV 19) Included is an FTIR of the violet crystal form which is a fairly close match (Figure 68).

6.3.3.3.2 Py-GC-MS Analysis

Three acrylic monomers were recognised in the pyrogram (Figure 69): methyl methacrylate, butyl acrylate and a trace of butyl methacrylate. Hence the binder in this paint is probably a methyl methacrylate/ butyl acrylate copolymer, the trace of butyl methacrylate could be either an impurity or was formed by transesterification during the pyrolysis.

6.3.3.4 Investigation of sample 4, Golden Company, Primary Cyan

6.3.3.4.1 FTIR Analysis

The spectrum (Figure 70) is typical of an acrylate /methacrylate copolymer type acrylic paint. (peaks at 2955, 2874 (C-H stretch), 1726 (ester carbonyl), 1233, 1138, 1066 (shoulder on 1099)(C-O stretch), and 754 cm^{-1}). The peaks at 1508, 1384, 1334, 780, 754 and 730 maybe due to PB 15 (Figure 71).

6.3.3.4.2 Py-GC-MS Analysis

Three acrylic monomers were recognised by Py-GC-MS analysis: methyl methacrylate, butyl acrylate and a trace of butyl methacrylate. Hence the binder in this paint is probably a methyl methacrylate/ butyl acrylate copolymer, the trace of butyl methacrylate could be either an impurity or was formed by transesterification during the pyrolysis.

Py-GC-MS pyrograms and FTIR spectrograms of these analyses are listed in (Table 4).

Table 4: This table includes all FTIR spectrograms and Py-GC-MS pyrograms of the four samples analysed; Raphael acrylic Gesso, Golden Primary Yellow, Golden Primary Magenta and Golden Primary Cyan respectively.

Sample 1, Raphael 'Acrylic gesso', white:

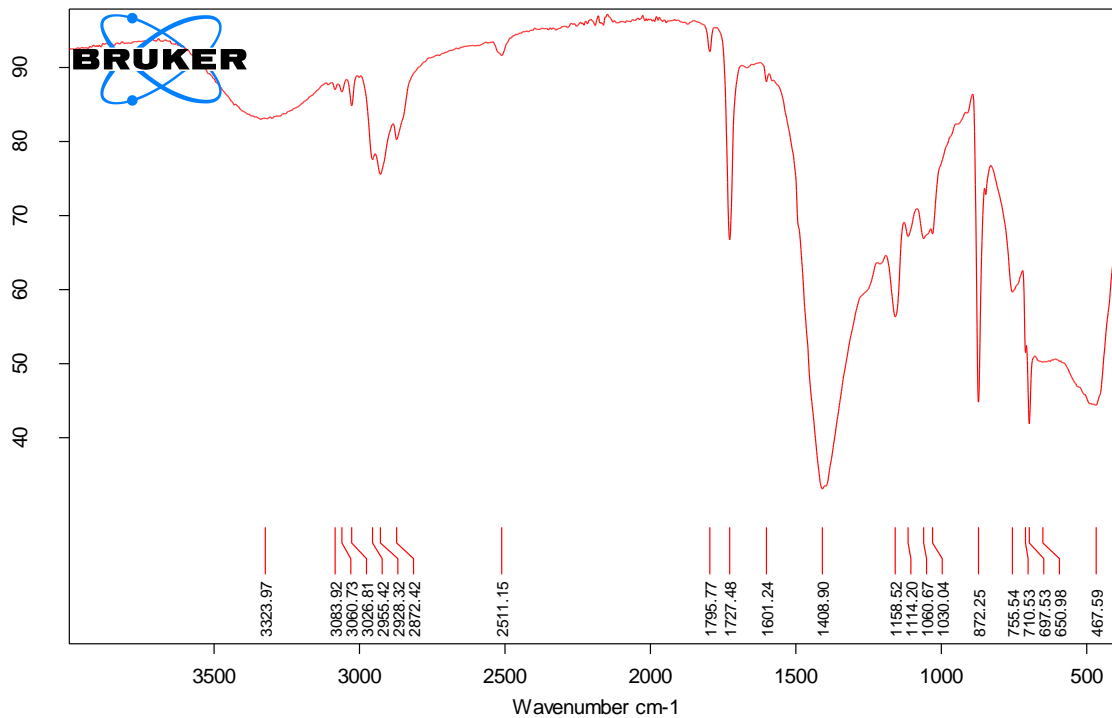

C:\alpha install data\Raphael company acrylic gesso.0	Raphael company acrylic gesso	Instrument type and / or accessory	21/11/2013
---	-------------------------------	------------------------------------	------------

Figure 58: FTIR spectrum of sample 1 Varnish sample from Dunham-M

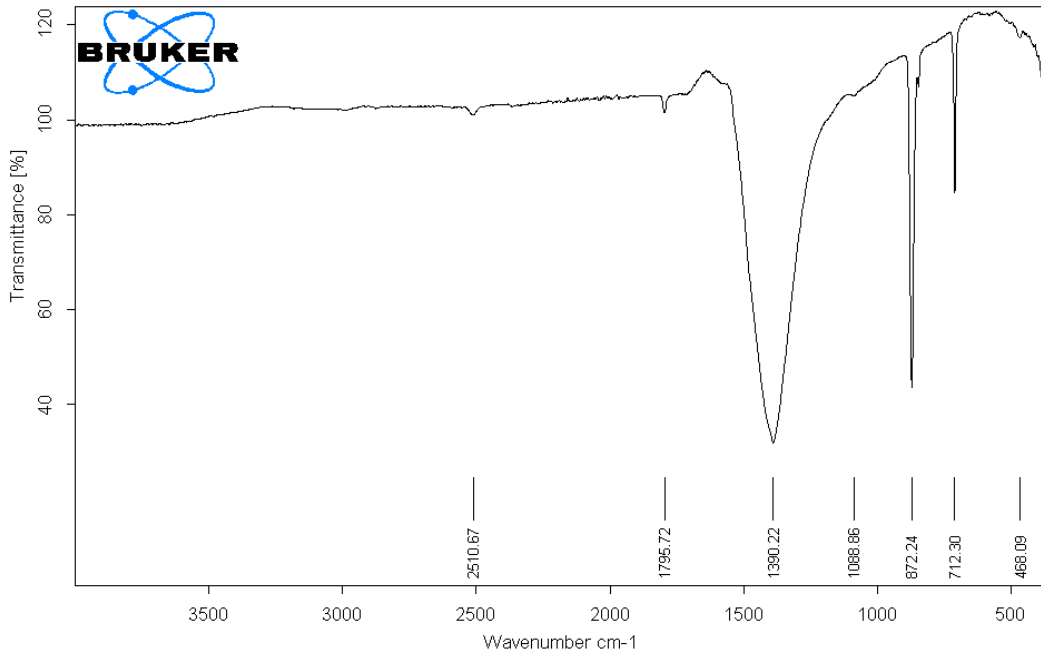

C:\alpha install data\Chalk (from Ruegen, Pigmal).0 Chalk (from Ruegen, Pigmal) Instrument type and / or accessory 03/12/2012

Page 1/1

Figure 59: FTIR spectrum of chalk

RT: 0.00 - 30.59

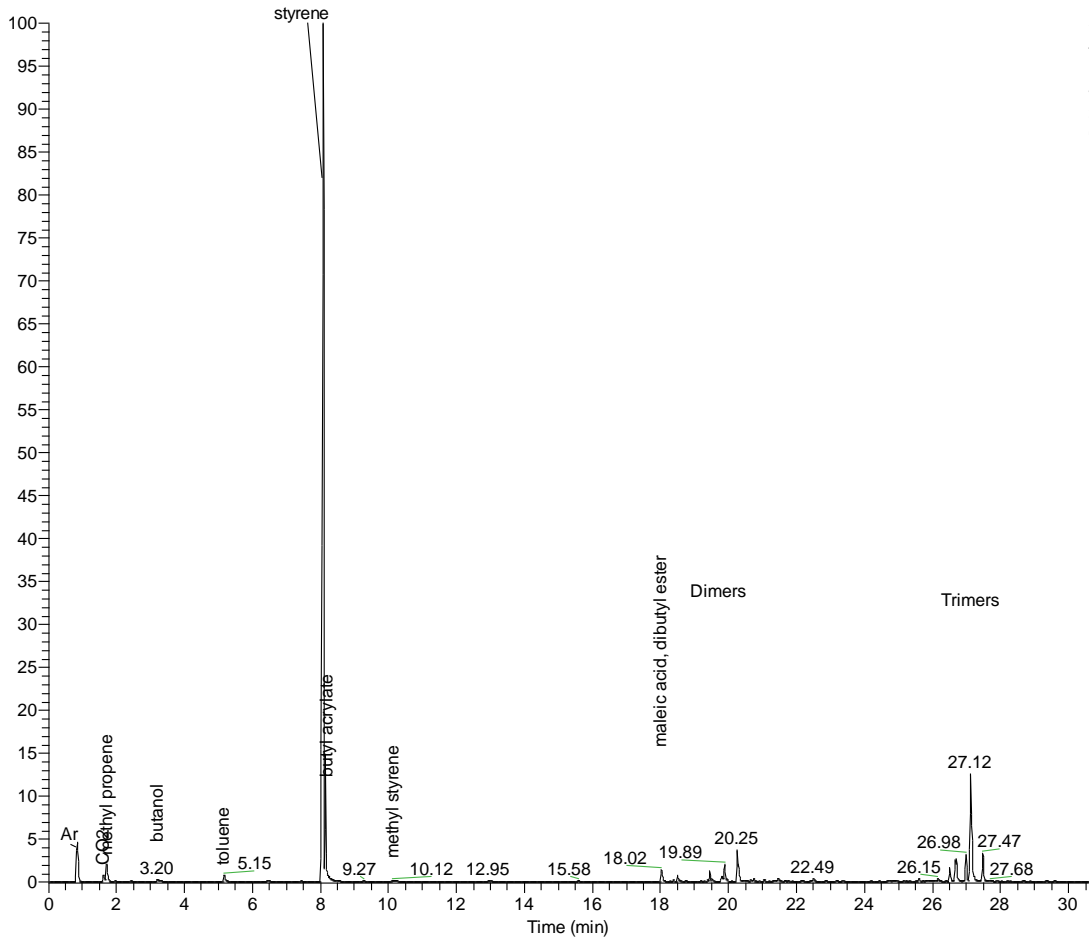

NL:
7.49E8
TIC F: MS
Raphaelacr
yklicgess_1
311251323
07

Figure 60: pyrogram of Raphael 'Acrylic gesso', white

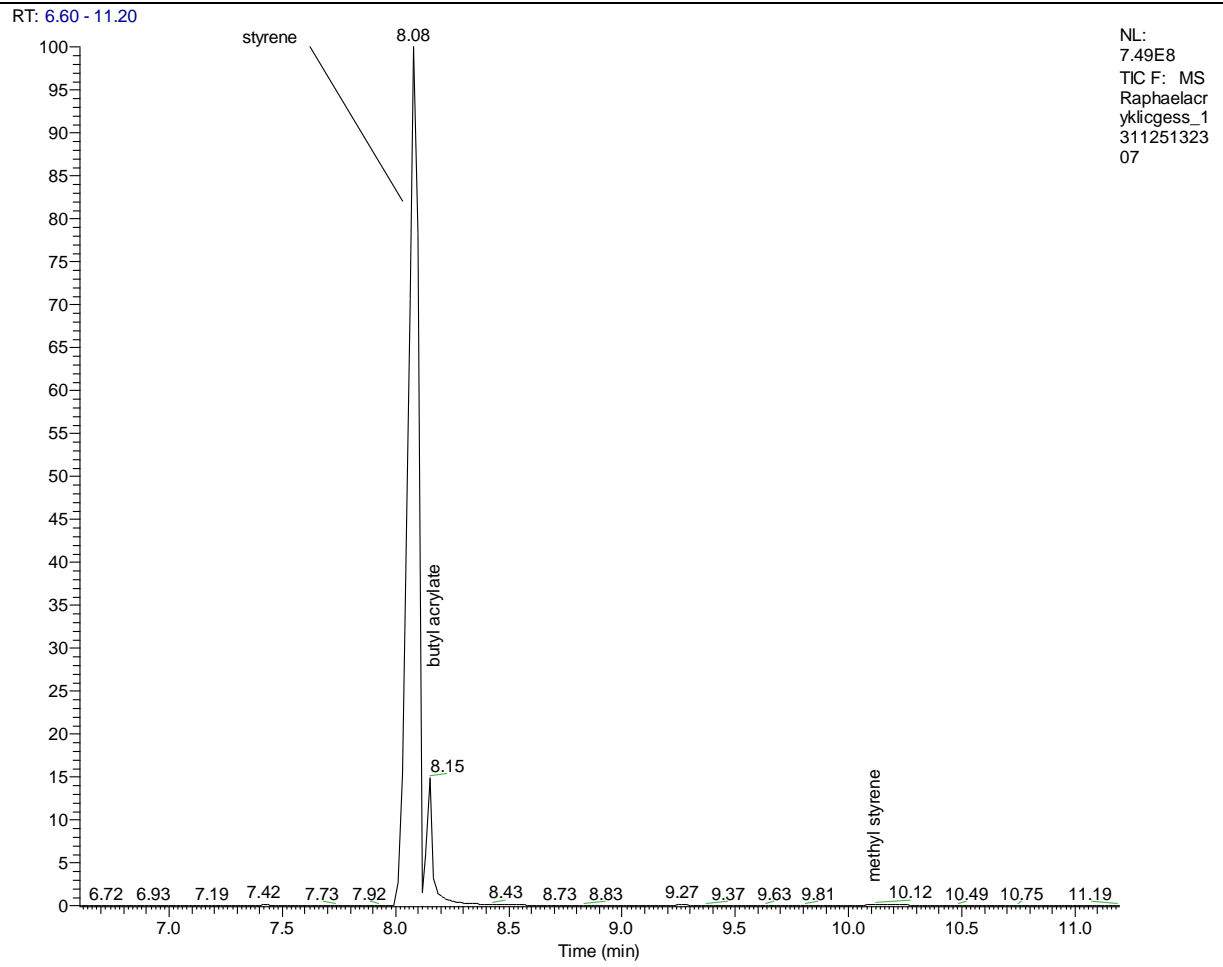

Figure 61: detail of , pyrogram of Raphael 'Acrylic gesso', white

Sample 2, Golden Company, Primary yellow:

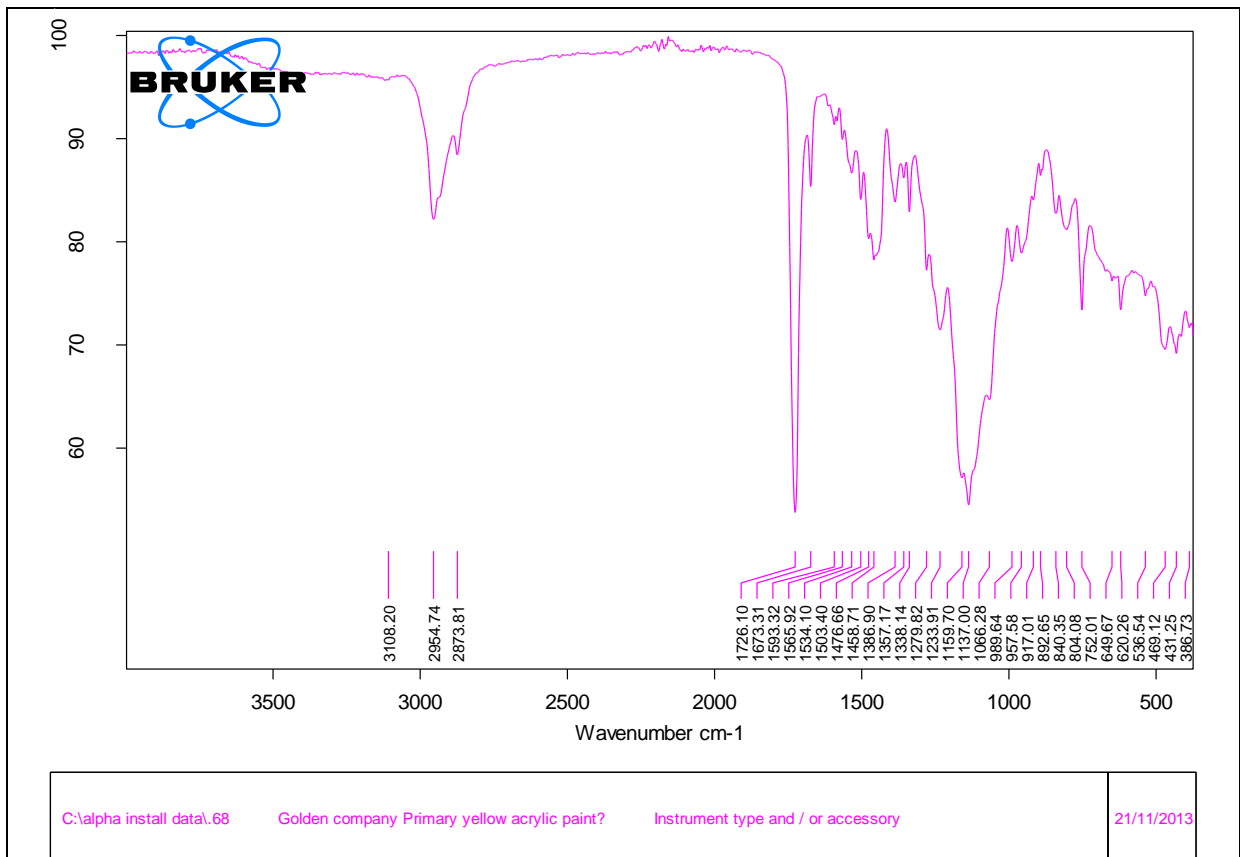

Figure 62: FTIR spectrum of sample 2, Golden Company primary yellow

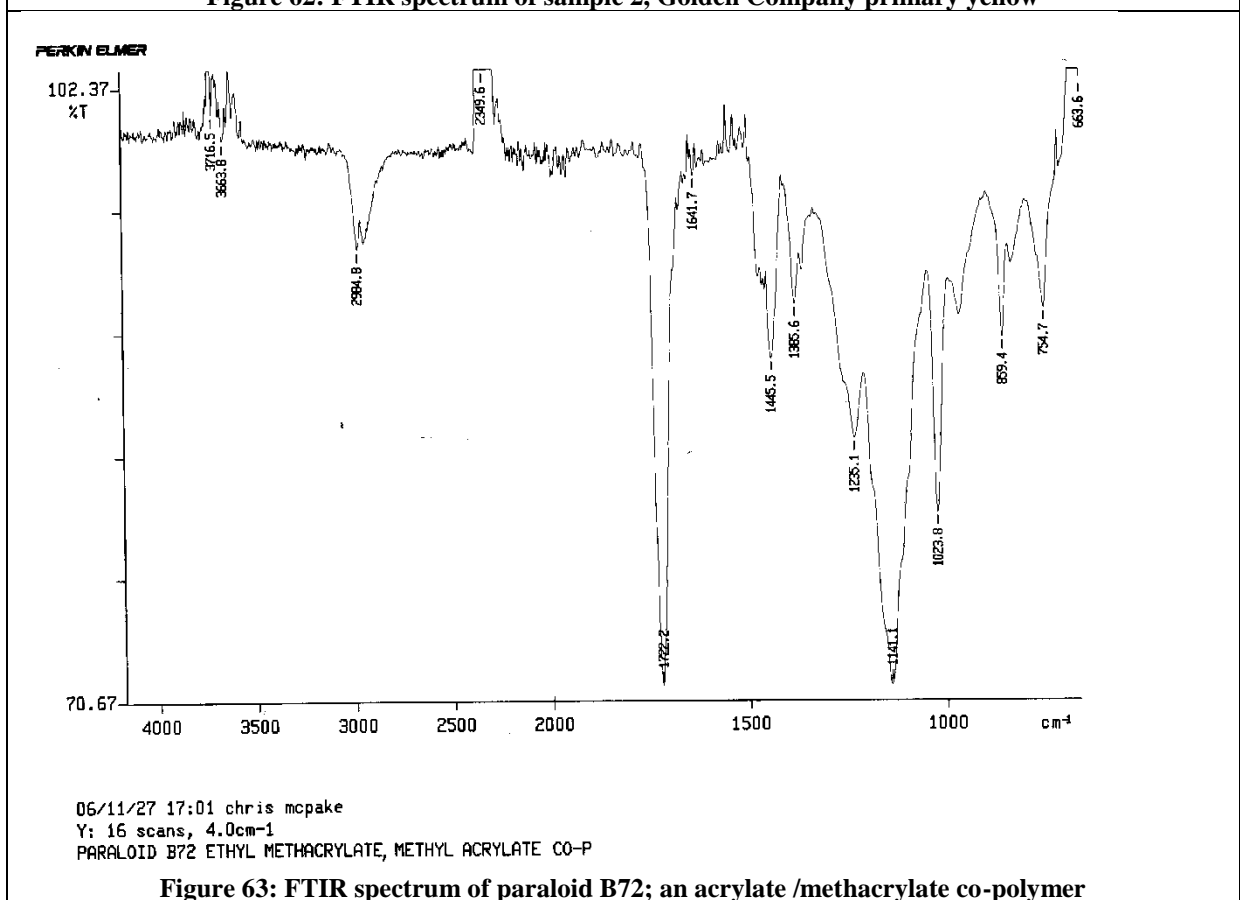

Figure 63: FTIR spectrum of paraloid B72; an acrylate /methacrylate co-polymer

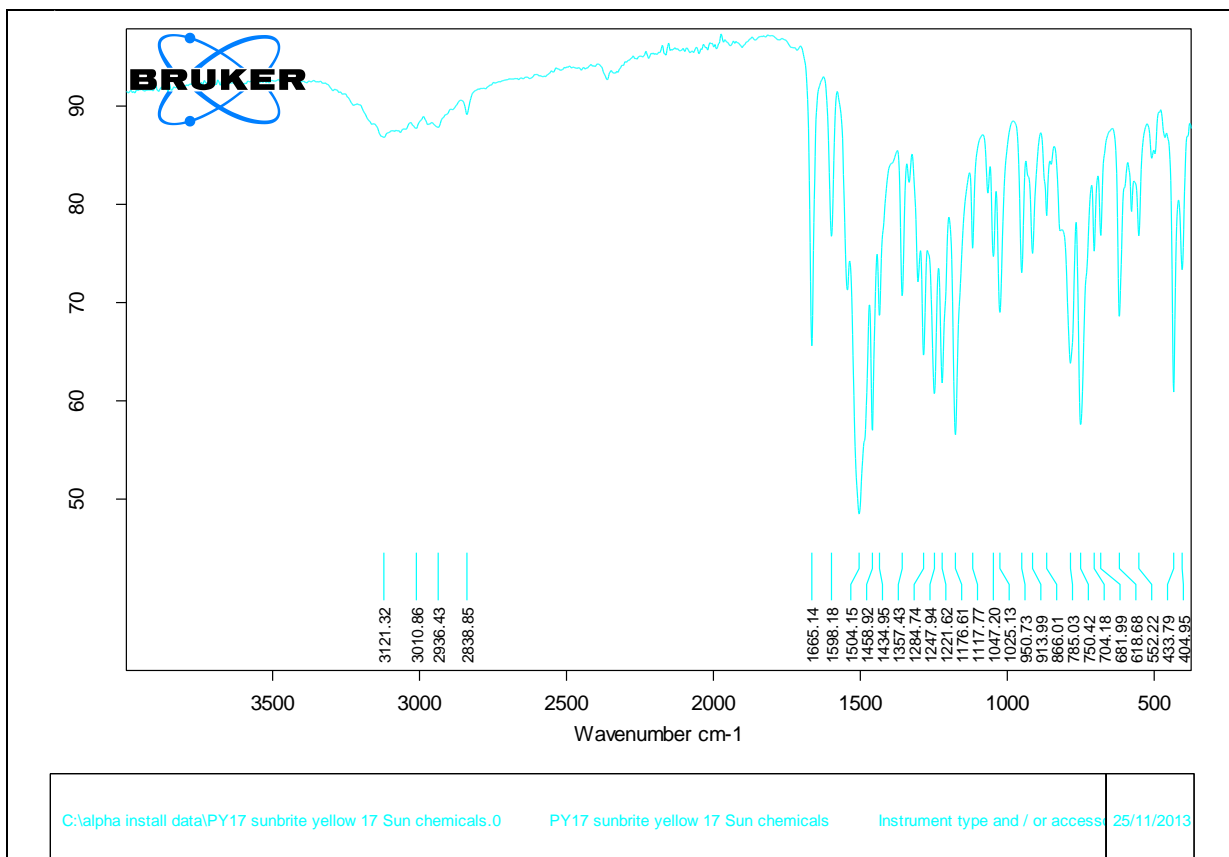

Figure 64: FTIR spectrum of PY17

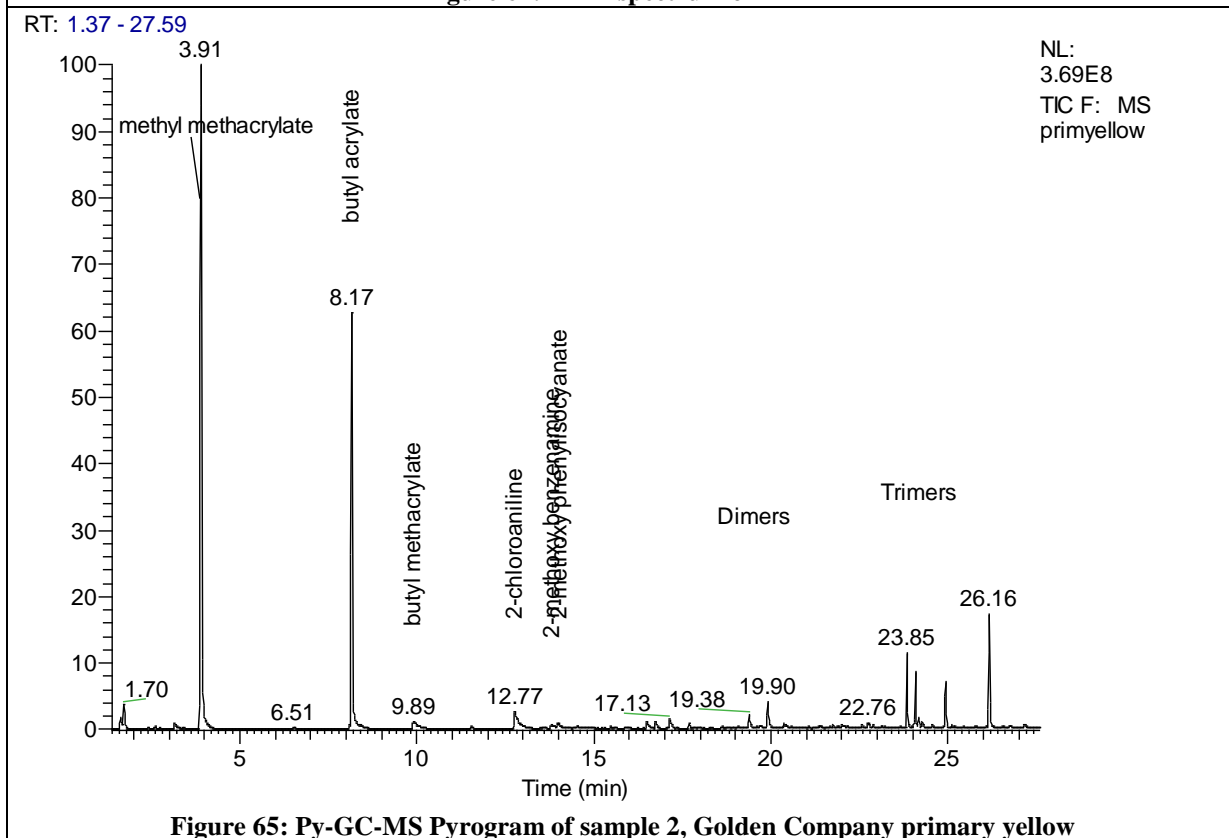

Figure 65: Py-GC-MS Pyrogram of sample 2, Golden Company primary yellow

RT: 1.60 - 15.21

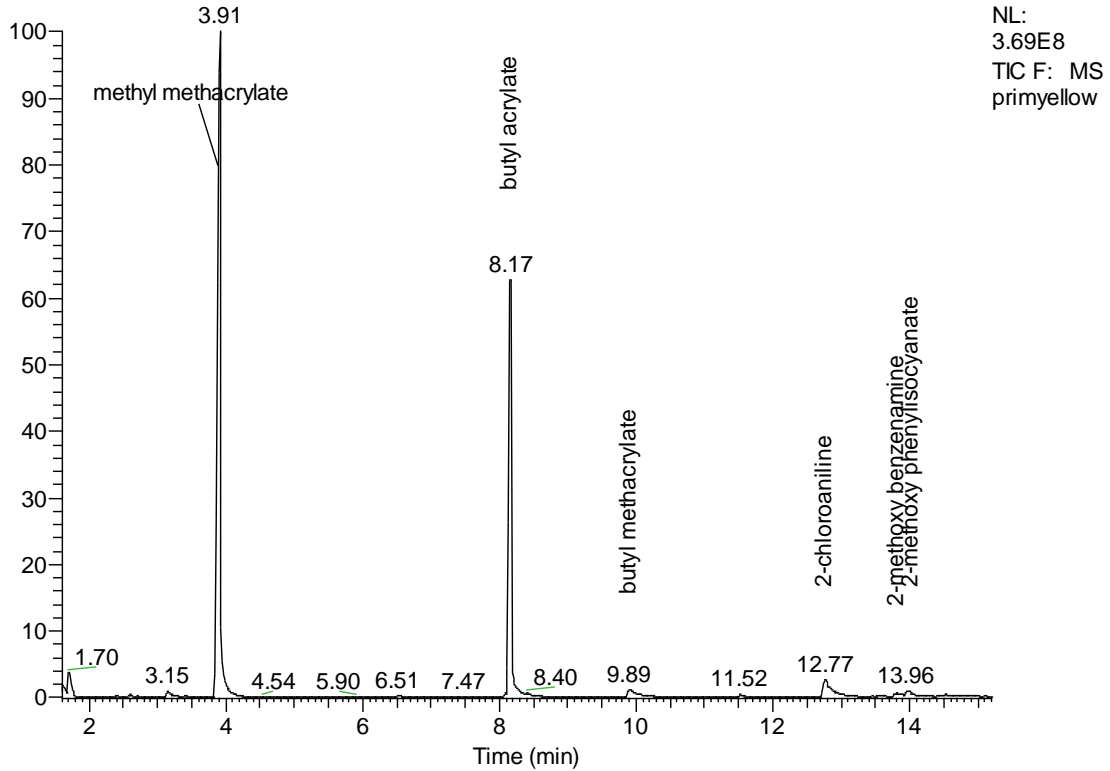
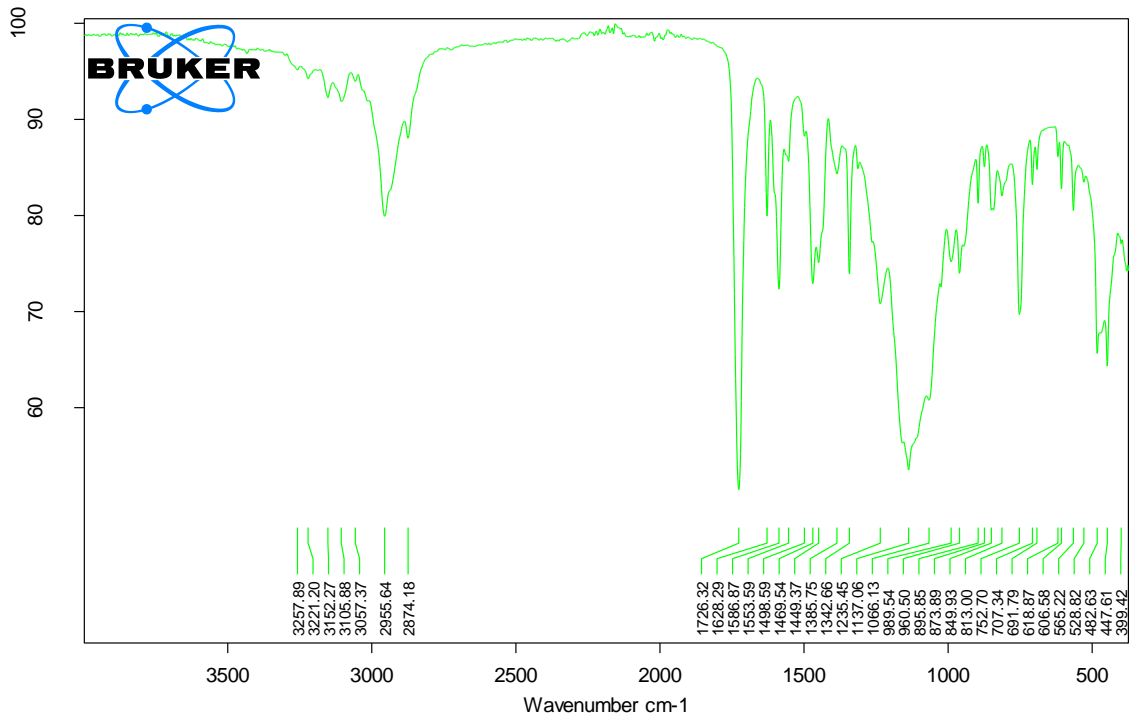

Figure 66: Py-GC-MS Pyrogram of sample 2, Golden Company primary yellow, detail 2-15 minutes

Sample 3, Golden Company, Primary Magenta:



C:\alpha install data\69

Golden company Primary magenta acrylic paint

Instrument type and / or accessory

21/11/2013

Figure 67: FTIR spectrum of sample 2, Golden Company primary magenta

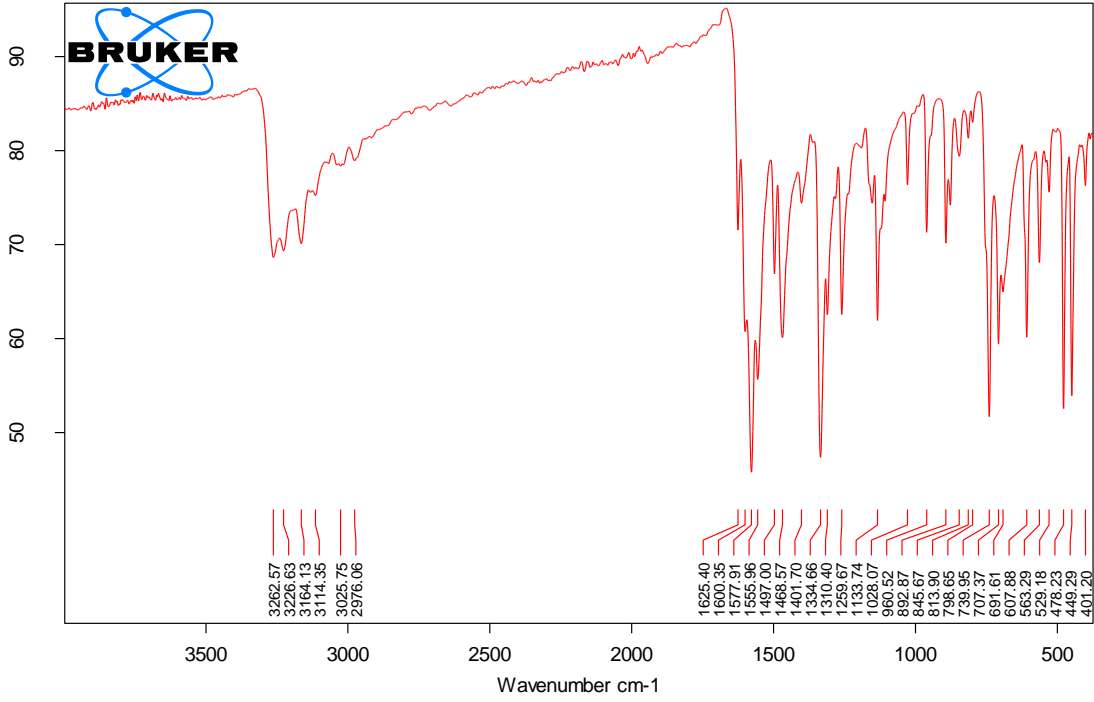

C:\alpha install data\PV19.0

PV19

Instrument type and / or accessory

25/11/2013

Figure 68: FTIR spectrum of PV19

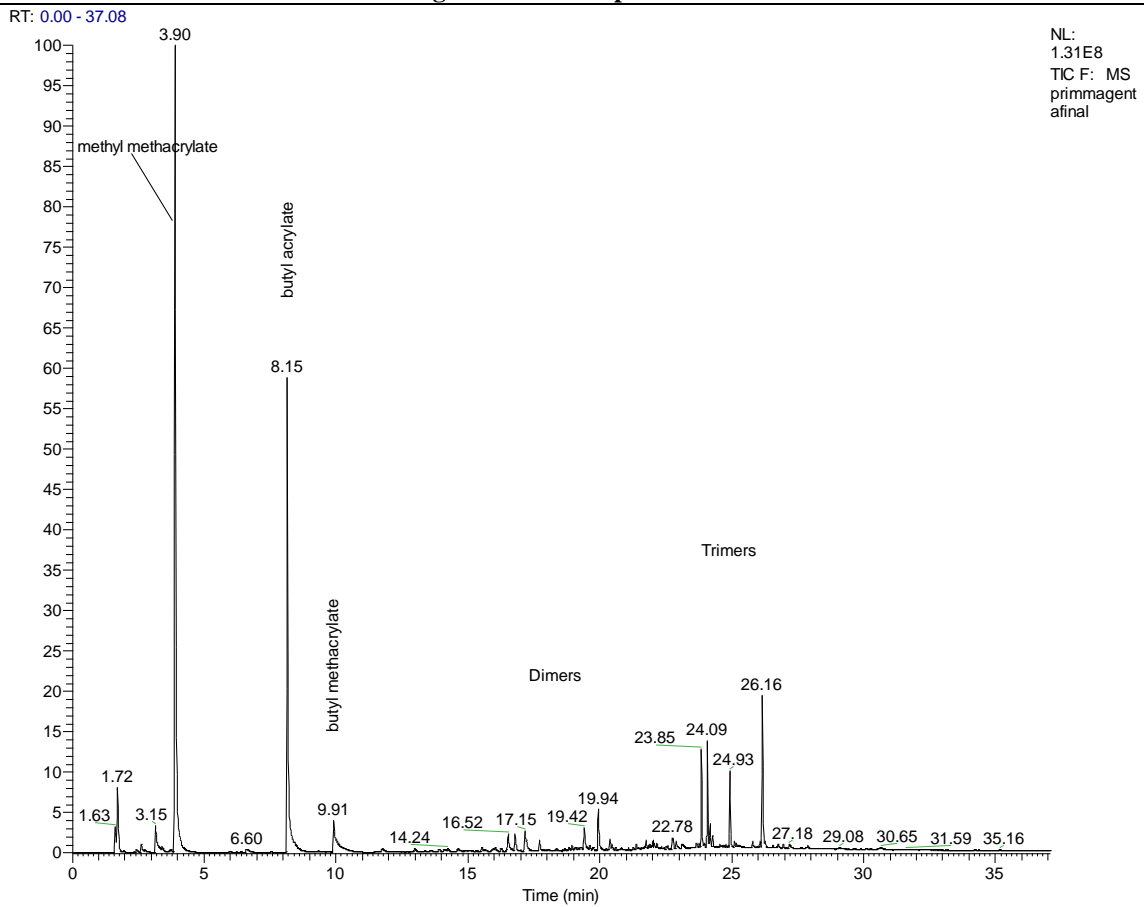
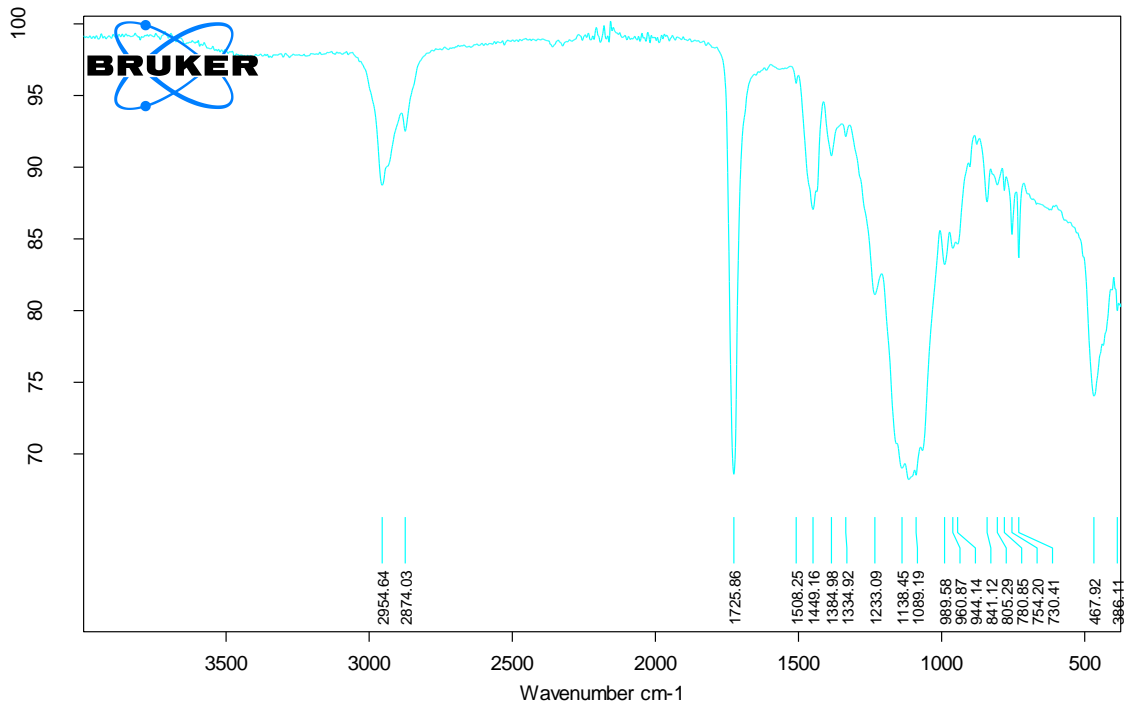

Figure 69: Py-GC-MS Pyrogram of sample 3, Golden Company primary magenta

Sample 4, Golden Company, Primary Cyan:



C:\alpha install data\70

Golden company Primary cyan acrylic paint

Instrument type and / or accessory

21/11/2013

Figure 70: FTIR spectrum of sample 4, Golden Company primary cyan

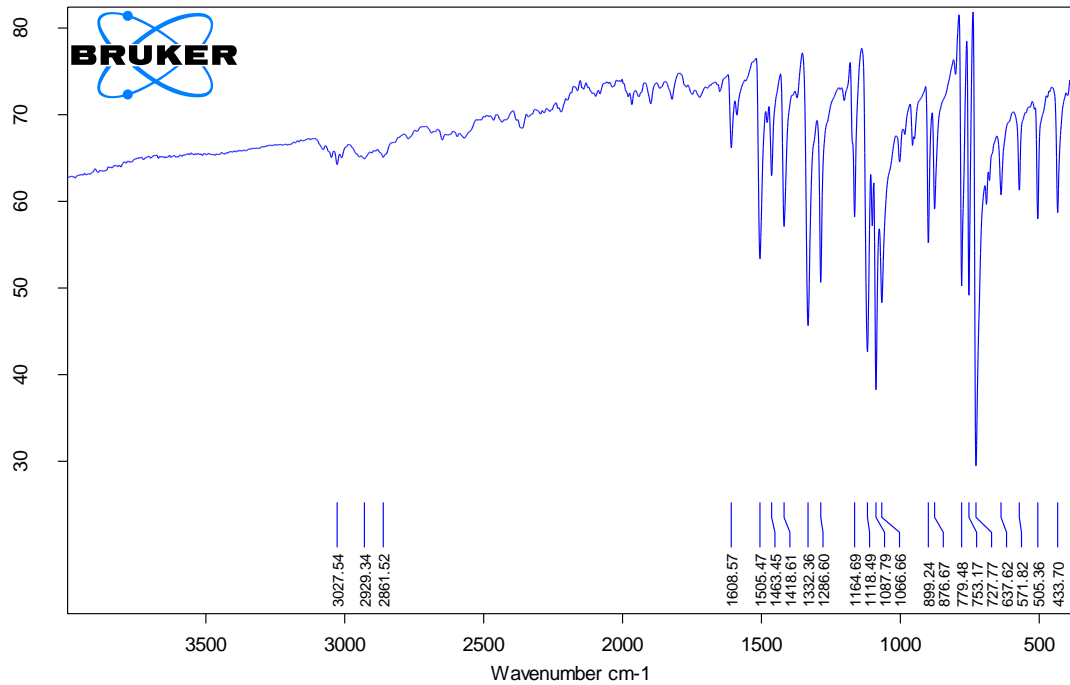

C:\alpha install data\PYB 15.3 Phthalocyanin blue

PYB 15.3 Phthalocyanin blue

Instrument type and / or accessory

25/11/2013

Figure 71: FTIR spectrum of PB15

6.3.4 Conclusions

Py-GC-MS and FTIR analyses confirmed the samples as acrylic emulsion based binder. The binding medium of the three Golden paint samples are found to be of Methyl methacrylate / butyl acrylate co-polymer, and the sample taken from Raphael gesso is found to be Styrene / butyl acrylate co-polymer.

Table 5: List of conclusions

Sample number	Description of sample	Analytical methods used	findings
1	Raphael Co. 'Acrylic gesso', white	FTIR, Py-GC-MS	Styrene / butyl acrylate co-polymer + chalk
2	Golden Company primary yellow	FTIR, Py-GC-MS	Methyl methacrylate / butyl acrylate co-polymer +PY17
3	Golden Company primary magenta	FTIR, Py-GC-MS	Methyl methacrylate / butyl acrylate co-polymer +PV19, red form
4	Golden Company primary cyan	FTIR, Py-GC-MS	Methyl methacrylate / butyl acrylate co-polymer +PB 15

6.4 Accelerated Light Ageing Tests

6.4.1 Introduction

“Light is a type of electromagnetic radiation. It is a source of energy that is capable of causing photochemical changes in materials that absorb it” (Oddy, 1992). Light-induced degradation is known to affect the paint layer in paintings in various degrees. Photo degradation appears in the form of fading, darkening or changing of the colour of certain types of paints. This can be observed in several pigments, inks, dyestuffs, etc. Paint binders can also be affected. It is now established that linseed oil, for example, darkens due to photochemical ageing. On the other hand, acrylic binders (poly methyl acrylate and poly methyl methacrylate) are generally considered “very stable” to light above 300nm (Schaeffer, 2001, p. 74). Accelerated light ageing has been employed in conservation science, mainly to assess the behaviour of the materials used in the works of art under irradiation in reasonably shorter lengths of time.

The purpose of this section of the present chapter is to demonstrate and discuss the accelerated light ageing tests performed using the same three acrylic paints analysed and investigated in the previous sections. That was carried out using one group of airbrushed samples and another group of brushed

samples in order to compare between the behaviour of two groups. The aims and objectives of this study are presented in further details in this section.

6.4.2 Overview of accelerated ageing methods in the field of art conservation

Accelerated, or artificial, ageing testing has been a fairly long established procedure for a vast array of purposes in areas within industry and academic research. It is considered greatly important in conservation research. Artificial ageing tests are set to predict – to a certain extent – the behaviour of materials with time under natural conditions by accelerating one or more of those conditions. Putting an object under a controlled accelerated ageing can be useful to observe its behaviour in short periods of time, so that a researcher does not have to wait for decades to achieve some results. The terms; artificial ageing, accelerated ageing and weathering are all used in different literature sources to denote the same procedure. Testing materials under controlled conditions to imitate natural ageing has been long used in the history of conservation research. An early accelerated ageing test was carried out in the late 19th century by Professor W. Herzberg, a German scientist who examined changes in properties of paper specimens under elevated temperatures (Porck, 2000, p. 19).

Artificial tests types and settings greatly vary, mainly according to the aim of research. Objects are exposed in artificial ageing tests to aggravated levels of one, a mix of two or more, of humidity, temperature, visible and ultraviolet radiation (Feller, 1994, p. 45), oxidation and acid-ageing (Young, 2005, p. 112). There is a wide range of physical and chemical stresses by which materials can be affected over time, and eventually deteriorate. Artificial (or accelerated) ageing became an established procedure that was already brought into the field of art conservation to test and assess a wide range of materials. It is, according to the aim of research, that the artificial ageing tests are employed for different purposes. According to Feller (1994) there are three major purposes:

- to establish “the relative ranking of materials”, such as in industrial quality control procedures,
- to assess the potential durability of an object,
- and to observe mechanisms of deterioration of an object.

Degradation occurs in almost all coloured objects at different levels, and paint films in paintings are not an exception. Apparently, deterioration to easel paintings – as to other objects – in natural environments occurs as a result of a set of complex influences, e.g. artificial or daylight, fluctuation in RH and temperature, pollutants, etc. However, deterioration might require an extended period of time to occur naturally to an easel painting. For example Brown (1995, p. 1) says that despite the fact

that the expected life span of polymer products vary considerably “it is generally measurable in years and can be 20 or even 50 years.” Moreover, natural deterioration is very difficult carry out in scientifically controlled conditions in order to achieve reliable results. Therefore, artificial ageing can be crucial where time is limited and controlled factors are required for testing the durability and stability of materials.

Accelerated ageing is yet to be fully standardised. In fact, it was found in the literature reviewed here, that each paper which discusses this subject proposes a method of accelerated ageing different from the others. It is not surprising that Luxford and Thickett (2011, p. 116) state that “for accelerated ageing there is no universal method”. However, Bansa (2002, p. 109) claims that “there are several standards for performing accelerated ageing tests, and ... they are rarely used as given”. Sometimes experimenters adopt a certain method of accelerated ageing that has been performed with materials other than the one they want to examine. For example, in order to design accelerated ageing experiments to study silk deterioration in historic houses, Luxford and Thickett (2011, p. 116) adopted a method for artificial light ageing that has been applied before to paper and photographic media.

It is important to distinguish as to whether artificial ageing is carried out for predicting the lifetime of certain materials, or for comparing two or more types of materials or techniques with regards to stability. Perrin et al (2001, p. 115), in a paper that discusses the application of artificial ageing to predict the lifetime of three paint systems, say that “the laboratory conditions, to be representative, must produce degradation mechanisms as similar as possible to the degradation occurring in the natural environment while the accelerating ageing phenomenon.” On the other hand, when accelerated artificial ageing is merely required “to routinely compare closely similar treatments on the same substrate” then “some simplification in the test protocol can usually be devised.” (Feller, 1994)

6.4.3 Aims and Objectives

The hypothesis of this research is that airbrushed paint layers might show, with ageing, signs of deterioration faster than those applied with traditional paint brushes, even where the paint medium is similar in both cases, because of the thinner application. Consequently, they may possibly pose aspects of damage that may require unconventional intervention for conservation treatment. Accelerated light ageing was chosen over other methods, e.g. heat and humidity, because it was required to avoid affecting the structure of the samples, and thus avoid unnecessary interference by other variables. According to Young (2005, p. 112) “Data obtained from ultraviolet (UV) filtered light ageing suggested that penetration of light through the upper layers of the complete composite should not significantly affect the mechanical properties of the underlying canvas”. We propose that, light ageing might affect the colourfastness of airbrushed paint films relatively rapidly compared to their

equivalents executed with traditional techniques. A comparative examination and analysis approach was taken to achieve meaningful results to test the research hypothesis in the following light ageing tests:

6.4.4 Accelerated Light Ageing Test no. 1

6.4.4.1 *Sample preparation*

Samples were prepared using both airbrushing and brushing techniques. Those samples were all taken from one source of canvas support, gesso and paints to maintain similar properties in the structure of the samples. In other words, in order to establish a controlled experiment, the only one variable of the samples was the type of paint application while other factors were kept constant. Canvas was primed using white acrylic emulsion gesso of Raphael[®] brand. As described in several airbrush artists' instructions, several layers of the gesso were applied with a brush. Each layer was left to completely dry and then carefully and thoroughly sanded down until achieving a smooth finish. Six sections with the same dimensions were then allocated on the canvas support. Three of those sections were painted using an airbrush and the other three were painted with a brush.

The paints were all of Golden Artist Colors[®] brand being the same paints on which the analysis was reported in the first section of this chapter, (Table 3): Primary Cyan, Primary Magenta and Primary Yellow. As has been established by the chemical analysis presented in the first section of this chapter, the binding medium of those three paints is confirmed as acrylic emulsion, based on a methyl methacrylate / butyl acrylate co-polymer).

The airbrushing device used for paint applications was an Iwata[®] Neo gravity-feed, dual-action airbrush. The compressor used was an Iwata[®] Studio Series Silver Jet airbrush compressor. Finally, the six sections were neatly cut from the canvas. Now we have six samples with three different acrylic emulsion paints, three of them painted with an airbrush and the other three painted with a brush.

6.4.4.2 *Sample exposure conditions*

Before putting the samples in the ageing instrument, it was essential to quantitatively measure the wavelengths of the colours in the samples beforehand. This is to obtain comparative results of changes to original colour that may possibly occur to the paint film during - the artificial ageing process. For this purpose a handheld spectrophotometer was used to measure wavelengths of light reflected from the samples' surfaces. The spectrophotometer model used for these measurements was Konica Minolta CM2600d reflected light spectrophotometer equipped with Spectramagic 3.07 software to record numerical values for the colour. Three different small areas were allocated in each of the samples and assigned with codes. Each area was measured by the spectrophotometer to obtain

reference values and also to obtain values after each cycle of ageing. This spectrophotometer measures the reflectance of light (λ 400-700nm) by percentage in each of those particular areas. The samples were also photographed under normal and raking light to obtain references for visual examination.

The samples were then placed in the light ageing instrument. The equipment used for this procedure was Q-lab Q-SUN Xe-1 light-ageing instrument equipped with AutoCal CR20 to calibrate luminous intensity required for the test. To set the required lux value, the instrument used was Lutron LX-101 digital lux-metre.

To choose a period of 'normal' time by which lux/hours value is predicted, the "class of stability" of materials proposed by Feller (1994, p. 6) was followed. Feller divides museum materials into three classes of photochemical stability:

- Class A materials, of "excellent" quality suitable for use in conservation practice, were considered to be materials that might give at least 100 years of satisfactory service.
- Class B materials were those falling between the two, materials that possibly would give from 20 to 100 years' service.
- Class C, were considered to be those that would seriously degrade in less than 20 years of normal museum conditions.

According to these suggestions a period of fifty years was an average time that was proposed as a basis for calibrating lux/hour value. The reciprocity principle helped calculate the length of time required for the accelerated light ageing test. Saunders (1995, p. 66) maintains that "reciprocity assumes that each photon of light has an equal potential to cause damage, it is worth describing the probable mechanism of light-induced damage before proceeding," therefore "the damage caused by one hour of illumination at a level of 1,000 lux is equal to that caused by ten hours at a level of 100 lux and so on." In (Table 6), Smith (2007, p. 238) provides detailed suggestions towards the "relationship between hours of exposure to artificial simulated indoor sunlight and equivalent years of exposure to museum lighting" based on reciprocity approximation regarding average museum exposures (2950 hours/year at 150 lux).

Table 6: relationship between hours of exposure to artificial simulated indoor sunlight and equivalent years of exposure to museum lighting according to Smith(2007, p. 238), based on the factors: *Irradiance = 74,425 lux and ** reciprocity assumed, 2950 hours/year at 150 lux.

Artificial Aging* (hours)	Equivalent Museum Aging** (years)
22	3.7
44	7.4
110	18.5
202	34.0
436	73.3
796	133.9
1196	201.2

According to this information lux/hour value was calculated taking into consideration the following factor: average museum exposure per year is 2950 hours/year at 150 lux and 50 years are required to be simulated (Smith, 2007, p. 238), (Whitmore and Colaluca, 1995, p. 52). This gives us five weeks under around 80,800 lux, assuming reciprocity, based on an illuminance power input equivalent to 1 W/M². Under these conditions the average temperature and RH was calculated and found to be around 31.4°C of temperature and around 29.3% RH so the interference of these factors with light ageing results can be negligible.

6.4.4.3 Spectrophotometry Reading Procedure

As mentioned earlier, the Konica Minolta CM2600d reflected light spectrophotometer was used to measure the reflectance of light (λ 400-700nm) by percentage in the particular area chosen for comparison. The Spectramagic 3.07 software then recorded each of the five readings that were consequent to each ageing cycle. The following spectrophotometric graphs show a comparison between the artificially aged paint-brushed and the artificially aged airbrushed samples of each one of the three paints used in this experiment, e.g. artificially aged paint-brushed, primary cyan against artificially aged airbrushed, primary cyan and so forth.

The legends appear in the graphs are explained as follows (Rogerio-Candelera, Lazzari and Cano, 2013, p. 312):

The values of L*a*b* are roughly accurate to ± 1.0 .

L*a*b reflects the method used by machine to describe the colour by a numerical, three way axis graph (Figure 72).

L = luminosity (White= +L/ Black = -L), y axis

a = colour component dimension (red = +a /green =-a), x axis ‘

b = colour component dimension (yellow = +b/ blue= -b), z axis

C = Chroma = the colourfulness relative to the brightness of another colour that appears white under similar viewing conditions.

H= Hue = the property of light by which the colour of an object is classified as red, blue, green, or yellow in reference to the spectrum.

Δ = delta, symbol to indicate the degree to which a value has changed from the original (units are the respective item it is representing, e.g. ΔL = the change in degree of luminosity value).

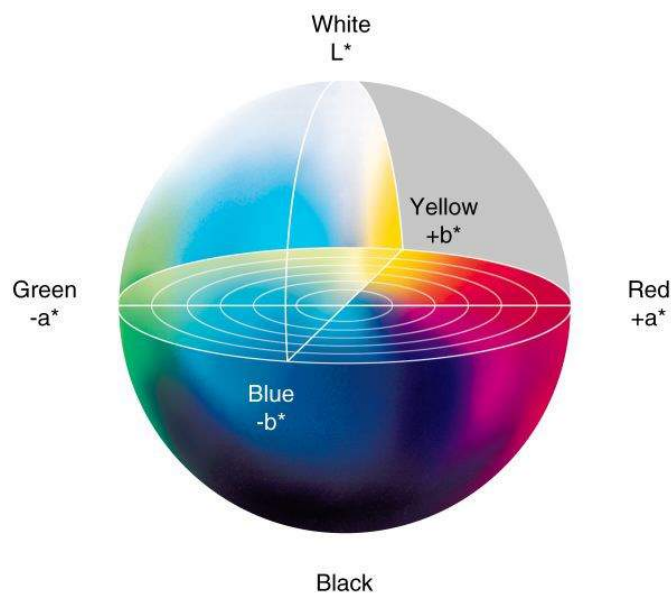

Figure 72: an illustration of a three way axis graph of $L^*a^*b^*$ which reflects the method used by the Konica Minolta CM2600d reflected light spectrophotometer to describe the colour numerically

The two spectrophotometric graphs in each of (Figure 125), (Figure 128) and (Figure 131) represent a comparison between two artificially aged airbrushed and paint-brushed samples. As mentioned earlier, all confounding factors were controlled and the one variable left was the technique of paint application. The samples are of acrylic primary cyan in (Figure 125), acrylic primary magenta in (Figure 128) and acrylic primary yellow in (Figure 131). Each graph shows six curves which represent six readings of which one of them represents the reference reading. The two axis of the graph represent reflectance against light wavelengths. The reference reading is the reading that was taken by the spectrophotometer at a certain spot on each of the samples prior to the process of the

artificial light accelerated ageing to use it as a reference for later readings. Readings were taken from those additional areas in order to ensure they confirm the previous results.

6.4.4.4 Results and conclusions

Each of the other five curves of each graph represents a reading of the same spot following every accelerated ageing cycle. The curve in blue represents the reading of the same spot on the sample following the final cycle of ageing. The degrees to which values have changed from the reference reading are comparatively presented in (Table 23), (Table 25) and (Table 27) which better resemble the results shown in the spectrophotometer graphs in (Figure 125), (Figure 128) and (Figure 131) respectively. The linear charts in (Figure 123), (Figure 126) and (Figure 129) represent timelines of the ageing cycles of the airbrushed samples, while the linear charts in (Figure 124), (Figure 127) and (Figure 130) represent timelines of the ageing cycles of the paint-brushed samples.

It could be noticed that the degrees to which values have changed from the reference reading are overall relatively greater in the airbrushed samples than those in the paint-brushed samples. This is particularly noticeable when we compare between the values of ΔE^*_{ab} ⁵⁷. The final ΔE^*_{ab} value of the airbrushed primary cyan acrylic sample is 2.63 whereas the final ΔE^*_{ab} value of the paint-brushed sample of the same paint is 1.15. In the airbrushed primary magenta acrylic sample the final ΔE^*_{ab} value is 4.30 whereas it is 3.59 in the paint-brushed primary magenta acrylic sample. Finally, the final ΔE^*_{ab} value of the airbrushed primary yellow acrylic sample is 7.96 whereas the final ΔE^*_{ab} value of the paint-brushed sample of the same paint is 4.25. These differences recurred in each of the spectrophotometric graphs of the readings of other areas on the surface of each sample. The linear charts show that all samples somewhat responded to accelerated light-ageing. Linear charts of the paint-brushed samples indicate slightly better stability to the test. This is particularly noticeable in the numerical differences between the two Cyan samples. However, those differences are almost negligible in most comparable samples.

These results indicate a measurable change occurred in colour value and luminosity in the aged samples, albeit indistinguishable by the naked eyes when compared to the corresponding reference (non-aged) samples. The following conclusions are presented for each colour is indicated by the numerical values measured in each sample:

⁵⁷ ΔE^*_{ab} is a distance metric introduced by the International Commission on Illumination (CIE) to describe the variations in total colour (Rogerio-Candelera, Lazzari and Cano, 2013, p. 229).

6.4.4.4.1 Cyan

A change in L^* numerical value indicates a change in luminosity in both types of samples which had undergone accelerated light ageing, slightly more in the airbrushed sample. On the other hand, an increase in b^* value of both types of samples (slightly more in the airbrushed aged sample) indicates a lower intensity of blue colour compared to that of the reference corresponding samples. In other words, the original blue was very slightly shifted towards +b (yellow) on the z axis (see Figure 72). Slight changes also occurred in the Chroma (C^*) and hue (h) values of both aged airbrushed and aged paint-brushed Cyan samples. Overall there are no significant differences in the changes that occurred to the colorimetric values of both airbrushed and brushed samples after ageing. However the change in the Chroma value in the Cyan airbrushed sample is somewhat particularly greater than that of the corresponding paint-brushed sample. This increase in Chroma value means that the colour in the airbrushed sample became darker by accelerated light ageing compared to the aged paint-brushed sample (Sikri, 2010). Detailed data of the numerical values of the non-aged and aged samples are presented in (Table 25).

6.4.4.4.2 Magenta

Both of the aged airbrushed and paint-brushed Magenta samples encountered a decrease in L^* value, which indicates that the colour in both samples became less luminous. However, it can be concluded from the numerical results of L^* that the luminosity of the aged airbrushed sample was more affected than the aged paint-brushed sample of the same Primary Magenta paint source. There is also a decrease in a^* value of both types of samples, (more in the airbrushed aged sample) which indicates lower intensity of red colour compared to that of the reference corresponding samples. In other words, the original red was slightly shifted towards -a (green) on the x axis. Slight changes also occurred in the Chroma (C^*) and hue (h) values of both aged airbrushed and aged paint-brushed Magenta samples. Overall there are no significant differences in the changes that occurred to the colorimetric values of both airbrushed and brushed samples after ageing. However the change in the Chroma value in the Magenta airbrushed sample is somewhat particularly greater than that of the corresponding paint-brushed sample. This increase in Chroma value indicates that the colour in the airbrushed sample became darker by accelerated light ageing compared to the aged paint-brushed sample. Detailed data of the numerical values are listed in (Table 26).

6.4.4.4.3 Yellow

Both of the aged airbrushed and paint-brushed Yellow samples encountered a decrease in L^* value, which indicates that the colour in both samples became slightly less luminous. However, it can be concluded from the numerical results of L^* that the luminosity of the aged airbrushed sample was more affected than the aged paint-brushed sample of the same Primary Yellow paint source. There is

also a decrease in b^* value of both types of samples (more in the airbrushed aged sample) which indicates a shift in intensity of yellow colour compared to that of the reference corresponding samples. In other words, the original yellow was shifted towards $-b$ (blue) on the z axis. Slight changes also occurred in the Chroma (C^*) and hue (h) values of both aged airbrushed and aged paint-brushed Yellow samples. Overall there are no significant differences in the changes that occurred to the colorimetric values of both airbrushed and brushed samples after ageing. However the change in the Chroma value in the Yellow airbrushed sample is somewhat greater than that of the corresponding paint-brushed sample. This increase in Chroma value indicates that the colour in the airbrushed sample turned darker by light ageing compared to the aged paint-brushed sample. Detailed data are presented in (Table 28).

(Note: tables, spectrophotometric graphs and linear charts of the accelerated light ageing test no. 1 are listed in Appendix B A.2.1)

6.4.5 Accelerated Light Ageing Test no. 2

In order to confirm the results, another accelerated ageing test has been performed. Different samples were prepared with the same materials and with the same procedure followed for test no.1. The second accelerated ageing test was performed following the same procedure followed in the first test, and with the same equipment and conditions of testing. The same spectrophotometer was also used to record possible colour changes after each ageing cycle.

6.4.5.1 Results and conclusions

Results of the second accelerated light-ageing test confirm those of the first test. Linear charts (in Figure 80, Figure 81, Figure 83, Figure 84, Figure 86 and Figure 87) indicate less stability in the airbrushed samples to artificial light ageing compared to the corresponding paint-brushed samples. The following conclusions are presented for each colour as indicated by the numerical values measured in each sample:

6.4.5.1.1 Cyan

Very slight change in L^* numerical value occurred in both types of samples. This indicates that the luminosity of the Cyan colour in the airbrushed sample was slightly affected compared to that of the paint-brushed sample. Also a very slight increase occurred in b^* value of both types of samples (slightly more in the airbrushed aged sample) indicates a lower intensity of blue colour compared to that of the reference corresponding samples. In other words, the original blue was very slightly shifted towards $+b$ (yellow) on the z axis (see Figure 72). Detailed data on these changes numerical values are shown in (Table 30).

6.4.5.1.2 Magenta

Both of the aged airbrushed and paint-brushed Magenta samples encountered a decrease in L* value, which indicates that the colour in both samples became less luminous almost equally. There is also an almost equal decrease in a* value of both types of samples, which indicates lower intensity of red colour compared to that of the reference corresponding samples. However the change in the Chroma value in the Magenta airbrushed sample is somewhat greater than that of the corresponding paint-brushed sample. This increase in Chroma value means that the colour in the airbrushed sample became darker by accelerated light ageing compared to the aged paint-brushed sample. Detailed data of the numerical values of the non-aged and aged samples are presented in (Table 32).

6.4.5.1.3 Yellow

Both of the aged airbrushed and paint-brushed Yellow samples encountered a decrease in L* value, which indicates that the colour in both samples became less luminous almost equally. There is also an almost equal decrease in b* value of both types of samples which indicates lower intensity of red colour compared to that of the reference corresponding samples. However the change in the Chroma value in the Yellow airbrushed sample is somewhat greater than that of the corresponding paint-brushed sample. This increase in Chroma value means that the colour in the airbrushed sample became darker by accelerated light ageing compared to the aged paint-brushed sample. Detailed data of the numerical values of the non-aged and aged samples are presented in (Table 34).

(Note: tables, spectrophotometric graphs and linear charts of the accelerated light ageing test no. 1 are listed in Appendix B A.2.2)

6.5 SEM (Scanning Electron Microscopy) imaging of the samples

6.5.1 Introduction to SEM

According to Egerton (2006, p. 17) electron microscopes were developed to be capable of examining a relatively thick specimen. The instrument is based on the idea of the use of a scanning principle with electrons. The principle is to cause primary electrons to be “focused into a small-diameter electron probe that is scanned across the specimen, making use of the fact that electrostatic or magnetic fields, applied at right angles to the beam, can be used to change its direction of travel. By scanning simultaneously in two perpendicular directions, a square or rectangular area of specimen (known as a raster) can be covered and an image of this area can be formed by collecting secondary electrons from each point on the specimen.” (Egerton, 2006, p. 17)

SEM instruments are used to examine very small details in a specimen that cannot be detected using light microscopy. It is capable of revealing details of dimensions less than one nanometre and with a

high resolution. It can also be equipped with an EDX (or EDS) attachment (Energy-dispersive X-ray spectroscopy) which allows measuring and analysing the elemental composition in a specimen. The SEM instrument is connected to a computer by which the imaging results could immediately be examined through its monitor, using dedicated software that is supplied with the instrument.

6.5.2 Aims

The aims of utilising SEM imaging in this research are:

- to visually examine topographical features of the paint surface of the samples
- to visually determine if there are common features in samples from similar groups: e.g. to see if aged (or non-aged) samples have common characteristics.
- to visually examine and compare aged and non-aged samples of the same paint source, and look for any potential radical differentiations in characteristics in those samples.

6.5.3 Procedure

An FEI Quanta 200 low-vacuum SEM instrument was used to examine the topography of the surfaces of the paint samples used in this research. The surfaces of both the aged and non-aged samples (airbrushed and paint-brushed) were examined under the high magnification of the SEM. The aim of this examination was to look further into any potential differentiations among the samples groups. The paint sample groups consisted of four distinct groups: aged paint-brushed, non-aged paint-brushed, aged airbrushed and non-aged airbrushed. The preparation of those samples was presented earlier in this chapter. Small cuts were taken from those samples in order to make them fit in the specimen chamber of the SEM instrument. Because the samples are obviously non-conductive, their surfaces were first coated with conductive metal to obtain optimal imaging results⁵⁸. Each sample was then placed into the specimen chamber of the SEM instrument. Each sample was recorded at magnifications of 250X, 1,000X and 10,000X. An image from each magnification was then saved as a digital media file JPG to keep records and facilitate further examination.

⁵⁸ According to Echlin (2011, p. 258): “The best and simplest way to overcome charging problems is to deposit (coat) a very thin (nm) layer of a conductive metal on the surface of the sample... Any localized conductive region eliminates electric fields above the sample surface, and although the specimen is charging, incoming and outgoing electrons do not experience any fields.

The function of thin layers of conductive material is to:

1. Increase the surface electrical conductivity of the sample
2. Increase the surface thermal conductivity
3. In some cases, to increase the SE and BSA signal from the sample”

The same procedure was repeated following the second accelerated light-ageing test.

6.5.4 Results and conclusions

No indicative differences can be seen between the SEM images of the samples of the same paint source according to their ageing vs. non-ageing status. This could be understandable, as the accelerated ageing-test might not have affected the topography of either airbrushed or paint-brushed samples. However, SEM images show noticeable topographical differences among the samples according to the paint application methods. In other words, the surfaces of the airbrushed samples show a much higher degree of smoothness and better evenness than those of paint-brushed samples. This is shown in the SEM images examples in (Table 7). All SEM images are, however, listed in the appendices. For normal visible comparison, the photographs listed in (Table 8) represent the aged samples compared to the non-aged reference samples that are corresponding to them in colour and technique of paint application.

Table 7: comparison between airbrushed and paint-brushed samples, in terms of their topographical features, shows that paint-brushed samples' surfaces are more 'rough' than those of airbrushed samples. All these SEM images are recorded at 1,000X magnification.

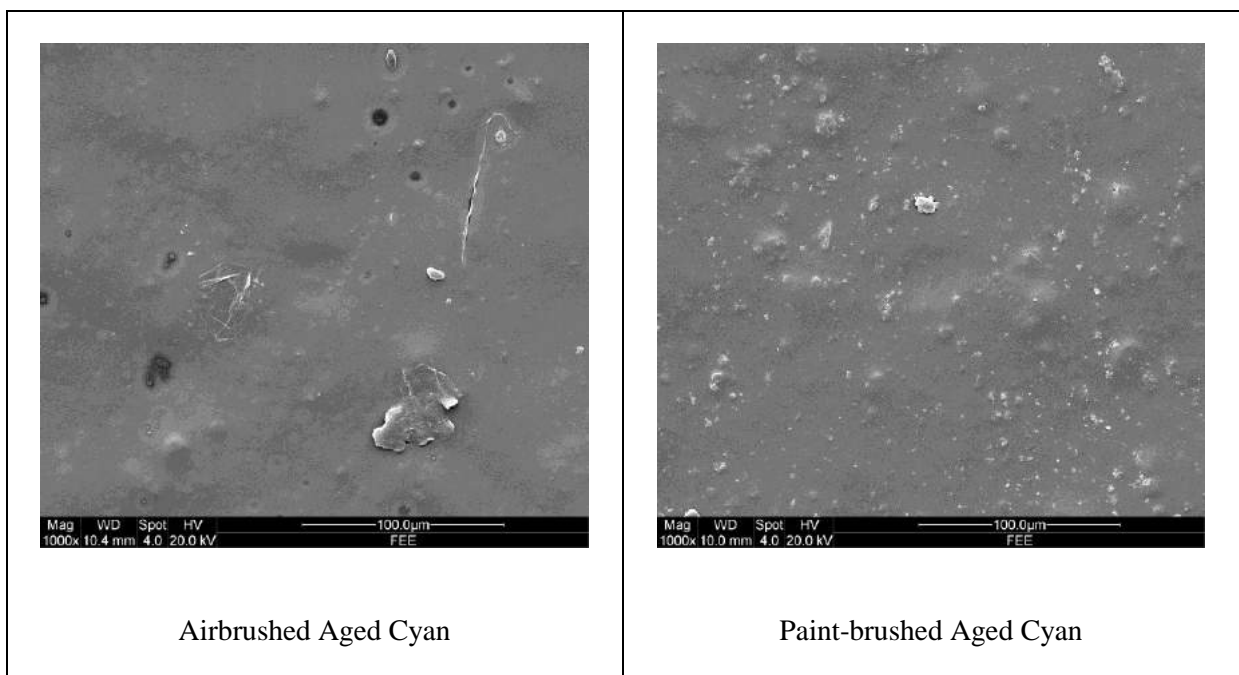

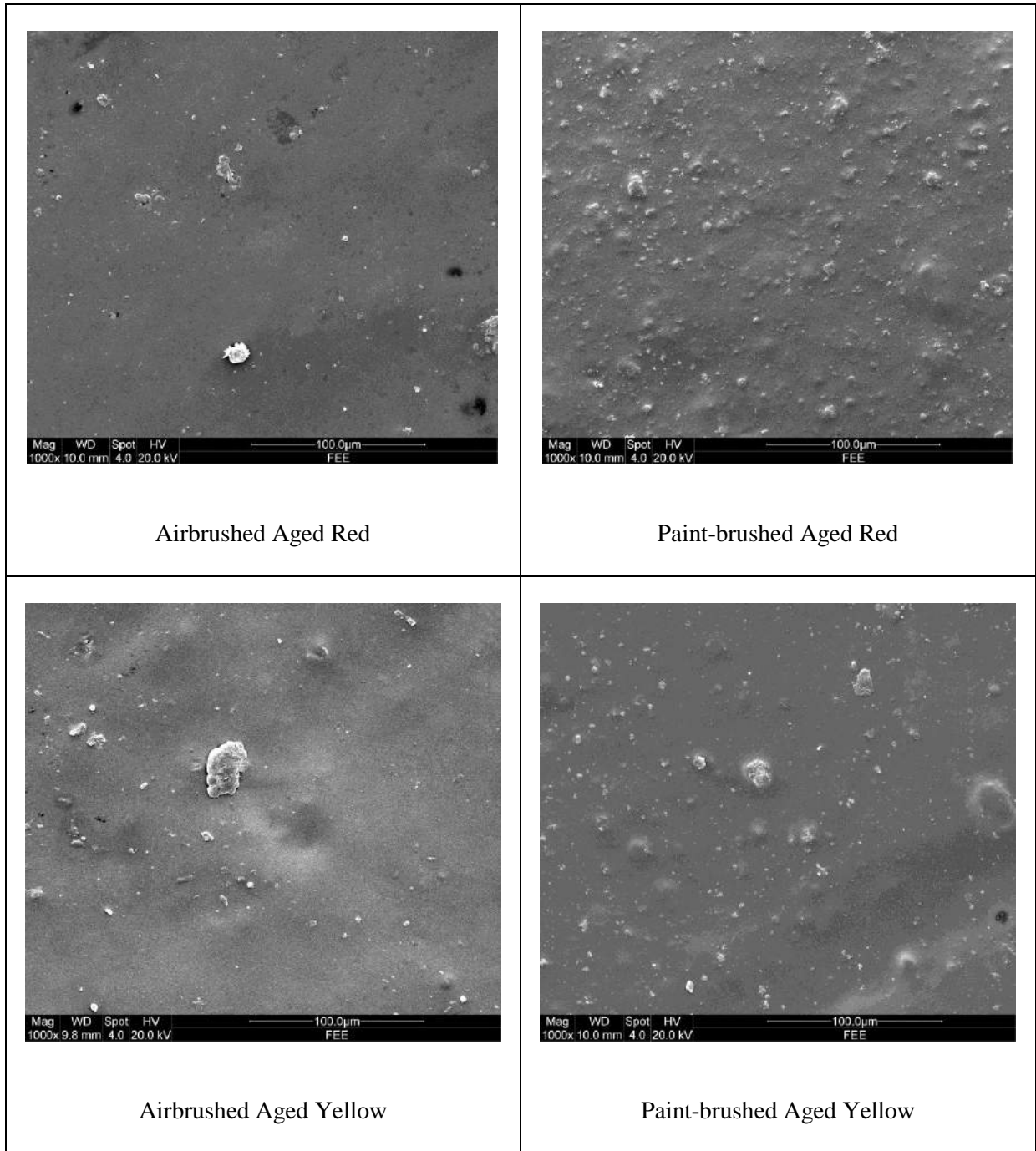
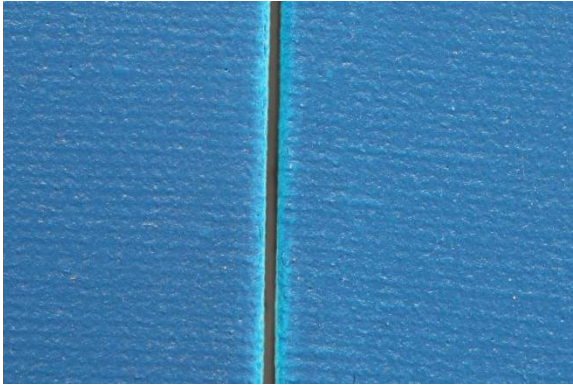

Table 8: photographs the aged samples compared to the non-aged reference samples that are corresponding to them in colour and technique of paint application

<p>Airbrushed samples, (left: non-aged – right: aged)</p>	<p>Paint-brushed samples, (left: non-aged – right: aged)</p>
--	---



Primary Cyan



Primary Cyan

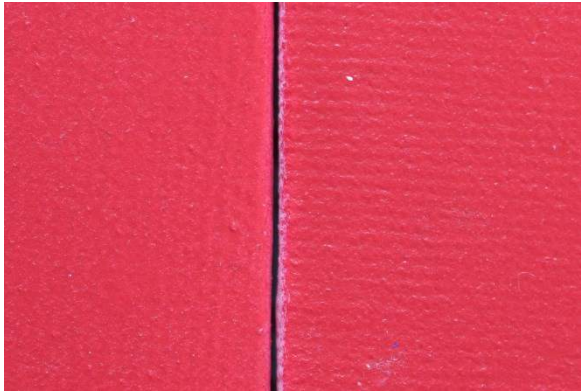

Primary Magenta



Primary Magenta

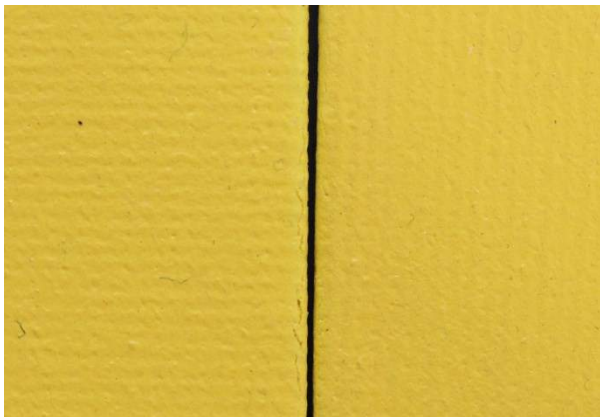

Primary Yellow

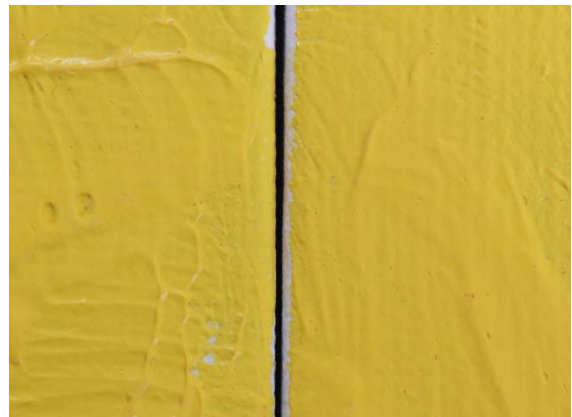

Primary Yellow

CHAPTER 7 - Suggestions for Possible Treatments to Image-

Reintegrate Airbrush Paintings

7.1 Introduction

As discussed in the previous chapters, image reintegration of easel paintings' surfaces painted with airbrushing is even more problematic if compared to traditional easel paintings. The results of the survey, along with empirical observation derived from treatment trials, conducted by the researcher indicate this inference. The flat topography of the surface of a typical airbrush painting, which consists of millions of seamlessly contiguous dots of sprayed paints and lacks of brushstrokes, is the most distinct factor which causes further difficulties when it comes to image reintegration. With such an appearance even the tiniest defect would be obvious to the eyes of the viewers. In this chapter two unconventional methods are presented and their results are discussed. To carry out those methods a mock-up airbrushed painting was prepared as to be explained in the following section.

7.2 The Preparation of a Mock-Up Painting

A smaller scale mock-up painting was executed after a detail of Chuck Close's *John*⁵⁹ (Figure 73). The substrate of the mock-up painting is canvas with a size of 70 x 50 cm (Figure 74). Chuck Close's technique in his Photo-real airbrush paintings was followed to obtain for the sake of as faithful representation as possible to the actual painting. Fifteen⁶⁰ consecutive coats, of Golden® Sandable Hard Gesso, were applied⁶¹. Each layer was left until dried out then carefully wet-sanded with fine-grit sandpaper to achieve as smooth surface as possible before commencing to a subsequent layer. The process was repeated throughout all the fifteen gesso coats applied.

⁵⁹ *John* is one of a mugshot-like portrait series done by Close using the airbrush on large-sized canvases in the 1970s. That series is one of the finest examples of the use of airbrushing techniques in the history of fine art.

⁶⁰ The number of gesso coats applied by Chuck Close in his paintings was mentioned by the artist himself in a recorded interview hosted by Barbaralee Diamonstein-Spielvogel (*Inside New York's Art World: Chuck Close*, 1979) and also remarked by Robert Storr (1998, p. 43).

⁶¹ acrylic polymer dispersion based gesso

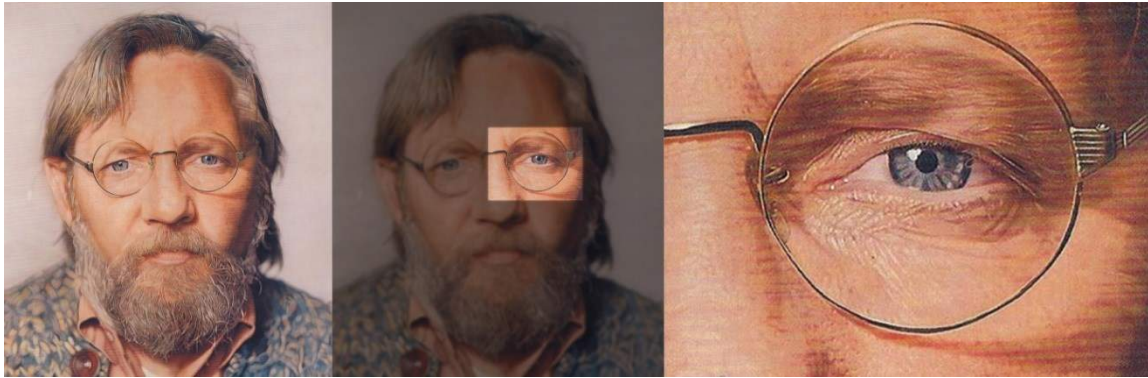

Figure 73: Left: *John* (1971-72) by Chuck Close, Acrylic on canvas, 100 x 90 inch. Middle: the place of the detail from *John* used as a reference for the mock-up painting. Right: larger view of the reference detail from *John*.

Chuck Close's technique of paint application was also followed. In his 1970s colour portraits series, Chuck Close applied three primary colours; red, blue and yellow directly on canvas using the airbrush. Accordingly, Golden® Acrylic emulsion based Primary Magenta, Primary Yellow and Primary Cyan were used to prepare the mock-up painting. Part of the method that Chuck Close used to construct *John*, and his other portrait paintings in the series, was to spray the paints directly on the canvas and to apply them one on top of each other⁶². Each monochromatic layer was corresponding to a monochromatic picture of the same photograph from which Close transferred his portrait painting. In this series, Close adopted a three-colour separation process used in commercial printing into painting⁶³ (Figure 75). That is much like the CMYK⁶⁴ method but without using black colour, and as in printing process the final product depends on the white colour of the substrate. The same approach was followed to create the mock-up painting.

⁶² In a lecture given by Chuck Close in May 2009 at Princeton University, he said about this technique: "I wanted to make a painting in which there was no palette, everything was mixed in the rectangle itself. To do that, I decided to make a red painting, a blue painting, and a yellow painting, on top of each other, and to try to build a four color image in the rectangle. So every square inch of the painting has some of all three of those colors. It's just a relative percentage of one color over another - more red than blue, or more blue than yellow - and how densely it's applied, which determines a generic value." (*Magnolia Editions*, 2009)

⁶³ In 1970, for the first time according to Storr (1998, p. 205), Chuck Close began experimenting with the three-color process: "The first works in this technique are two drawings and a watercolor of Kent Floeter (artist). He thus brings color back to his work in a technique of color separation derived from color printing. The first painting done with the three-color process is "Kent" (1970 - 71), executed in his Prince Street studio in New York." This method was adopted from printing technique used long time ago. The engraver Jacob Christophe Le Blond (1667-1741) of Frankfurt, was claimed to have been the "inventor" of such a technique. Le Blond made his mezzotint prints by superimposing red, yellow and blue monochromatic plates (Lilien, 1985).

⁶⁴ CMYK stands for Cyan, Magenta, Yellow and Key (Black). This is a colour-separation technique commonly used in printing processes



Figure 74: a mock-up painting carried out by the researcher following a detail from Chuck Close's *John*, photographed under reflected light

The model of the airbrush device used for spraying the paints onto the mock-up painting is Neo CN from Iwata which is a dual-action, gravity-feed airbrush. For air compression an Iwata Studio Series Silver Jet Airbrush Compressor was used. Following Close's technique, the reference detail digitally underwent colour separation using image editing software (Adobe® Photoshop® CC). Respectively; The Primary Cyan, Primary Magenta and Primary Yellow paints were individually applied in a consecutive, so that each layer corresponds to one monochrome of the colour-separated image that was digitally processed (Figure 76).



Figure 75: Chuck Close in his studio working in a mid-stage on *Mark*. This photograph shows Close's colour separation technique represented by the monochromatic images put on an easel stands by his left side. At that stage the Cyan/Magenta subsequent layers are still visible under *Mark's* left eye

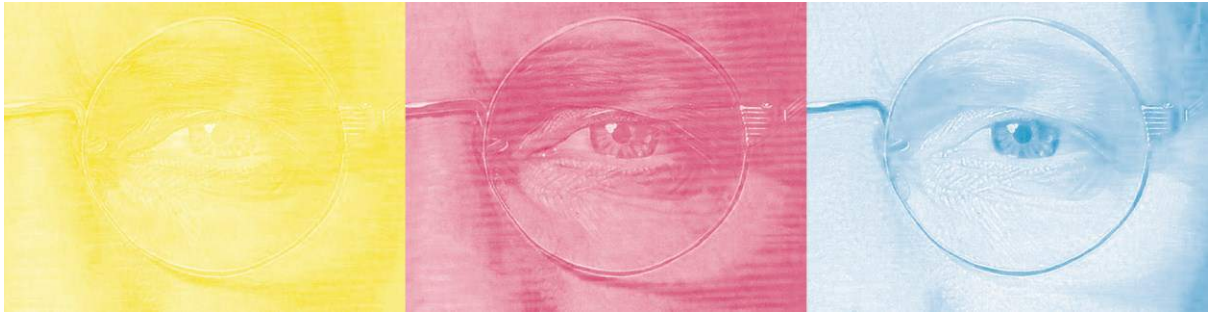

Figure 76: colour-separation of *John* detail, done digitally and then used as guidance for the preparation of the mock-up painting appears in Figure 2

After the completion of the mock-up painting, it was properly photographed under reflected light (Figure 74), raking light (Figure 77) and ultraviolet (UV) irradiation (Figure 79). The camera used for photography was a digital single-lens reflex (DSLR) Canon EOS 5D Mark I with a full-frame 12.8 megapixel CMOS image sensor. The surface appears particularly even under raking light (Figure 78). Under ultra-violet irradiation there are large areas of particularly light toned colour, indicating that those areas bear less thickness of paint layers and thus the ground layer shows through (Figure 79).



Figure 77: the mock-up painting of a detail from *John* (after Chuck Close), photographed under raking light. The texture appears even across the surface.

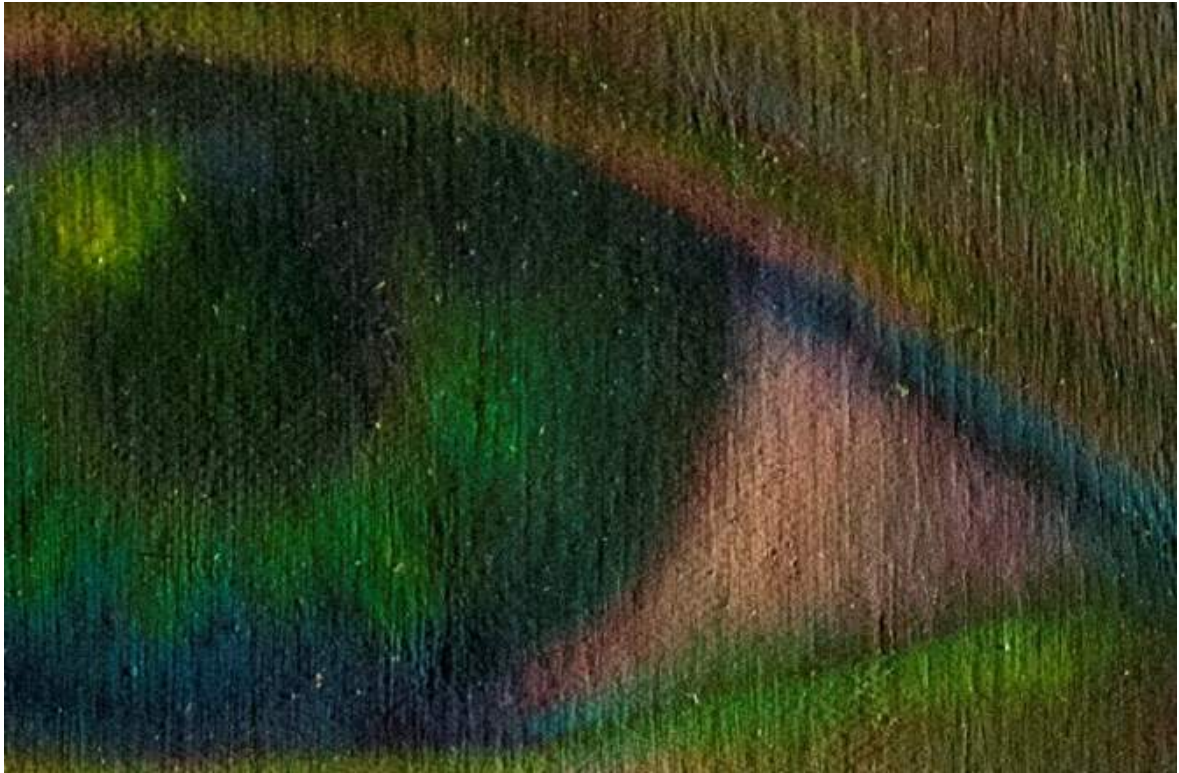

Figure 78: this close-up to the mock-up painting under raking light shows further detail of the surface. The very low thickness of the airbrushed paint layer is obvious as it appears as if embedded into the texture of the canvas.

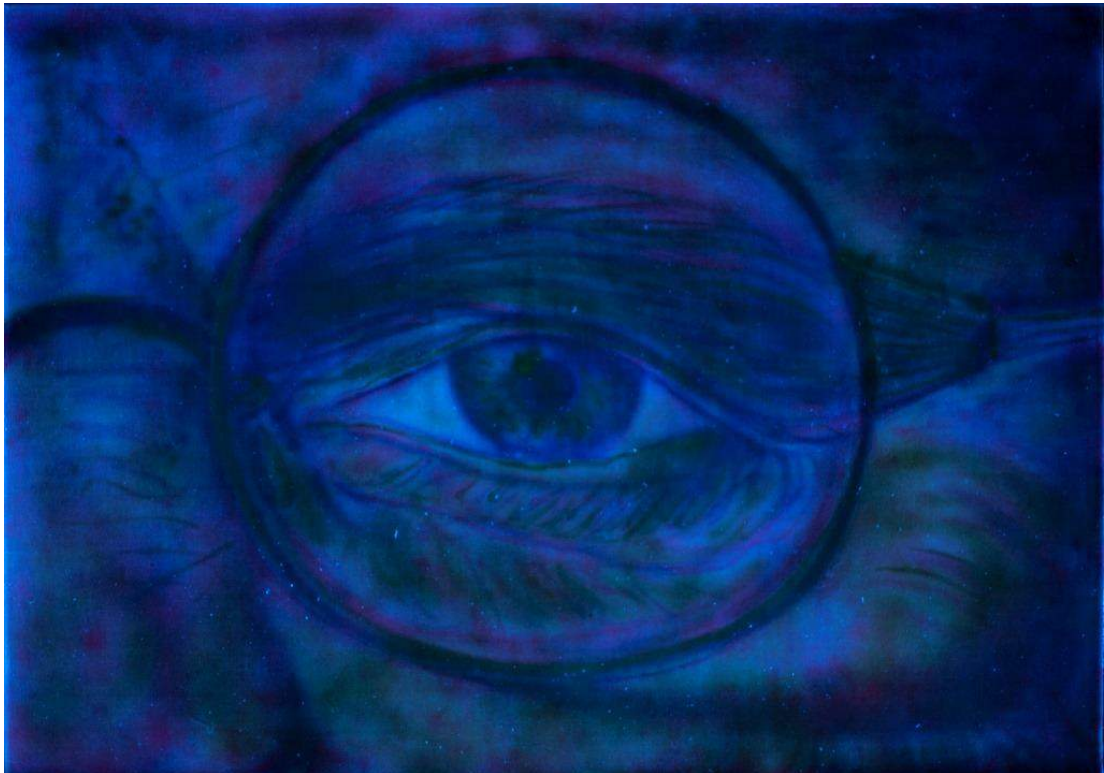

Figure 79: the mock-up painting of a detail from *John* (after Chuck Close), photographed under UV irradiation. The light tones indicate less paint applied.

Afterwards, losses were deliberately created in the paint surface, mainly at the bottom right corner of the mock-up painting (Figure 80). The damage was created in the form of scraping, using sandpaper with a higher grade of coarseness. This form of damage was chosen for two reasons; the first reason is that there is a considerable degree of probability such a ‘damage type’ which could occur, and the second reason is that this form of loss to paint would be even more problematic in terms of interventive image reintegration. Other losses to the paint surface were also deliberately created using a sharp object. The latter losses were made in the form of small squares to test printed infills as shown in a following section in this chapter.

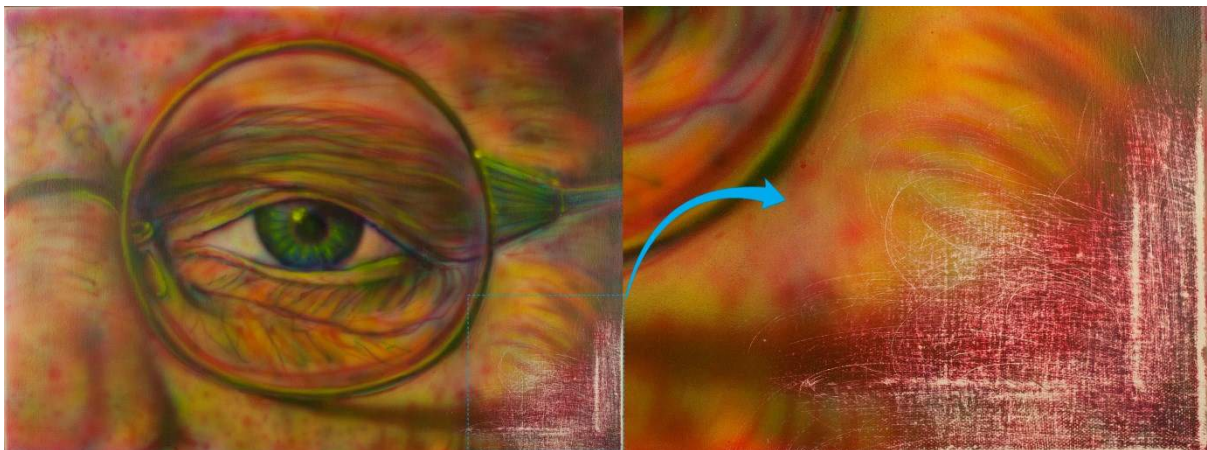

Figure 80: this area of the mock-up painting was deliberately damaged by scraping it using sandpaper

7.2.1 The Use of Interventive Imitative Image Reintegration

Two of the damaged squares were selected to undertake interventive imitative image reintegration. No filling was needed as the loss created was only within paint layers. Acrylic emulsion, gouache and watercolours were all experimented with, following recent image reintegration treatments done for acrylic paintings in the Tate (Smithen, 2007, p. 172). The brush used for this process is a 5/0 Spotter with very fine synthetic hair by Princeton Art & Brush. The paint was applied by dotting to try to mimic, as far as possible, the very fine spots sprayed with the airbrush. It was, however, extremely difficult to achieve, and accordingly, highly time consuming, as dotting made by hand could not achieve the tiny size of the sprayed spots. The process was nonetheless a bit easier in darker areas. However, the process was greatly time-consuming with a relatively small size of loss. More importantly, the results were generally found unsatisfactory. The manipulation of the paints used in the process also proved greatly difficult because of the surface tension of the droplets of the water-thinned paints. Such a very thinned paint caused, many times, patchy appearance, that would have to be worked again with the brush. Paints, which were not thinned very much, were better in terms of getting rid of surface tension and being able to better manipulate the paint. However they tended to

create a sort of unharmonized ‘dotty’ appearance with a resulting un-uniformed texture. The fact that the original colours were applied as consecutive separate layers, made the endeavour of imitating their final appearance with such a method, even more difficult.

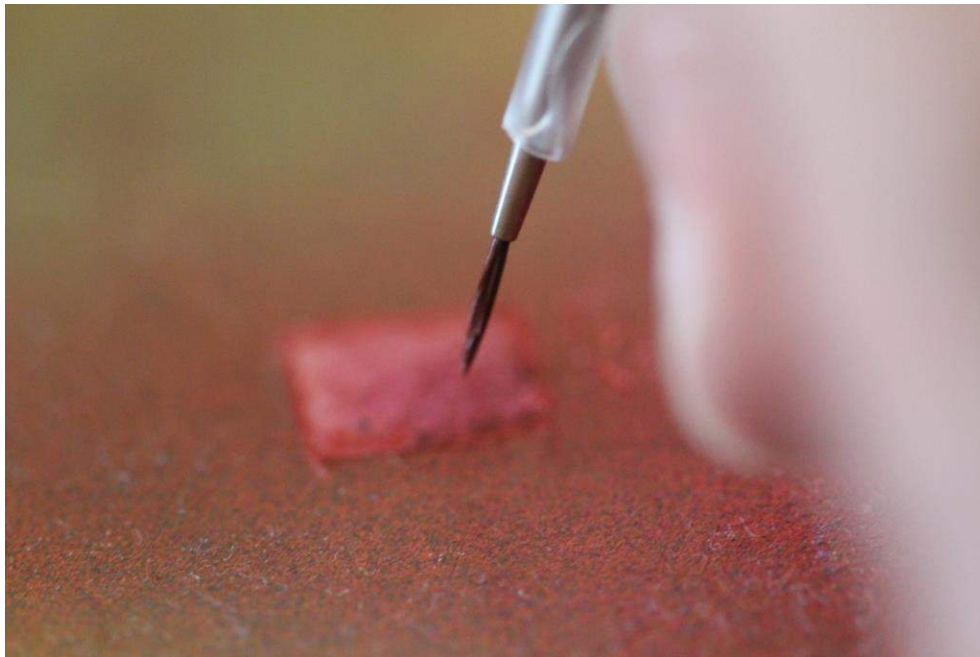

Figure 81: image taken during the process of a conventional imitative retouching of a fabricated loss in the mock-up painting

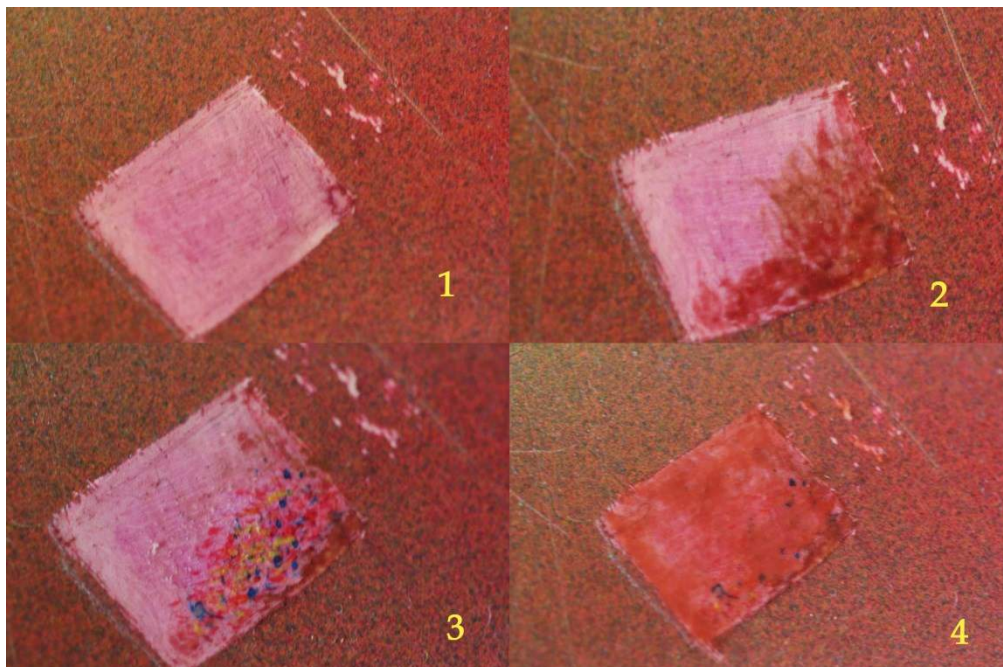

Figure 82: (1): the original loss made in the mock-up painting, (2, 3 and 4): examples of attempts of interventive image reintegration carried out on the same loss. the attempts were unsuccessful because the ultra-fine dots of the sprayed paints surrounding the loss could not be mimicked in spite of the use of a fine spooter paintbrush

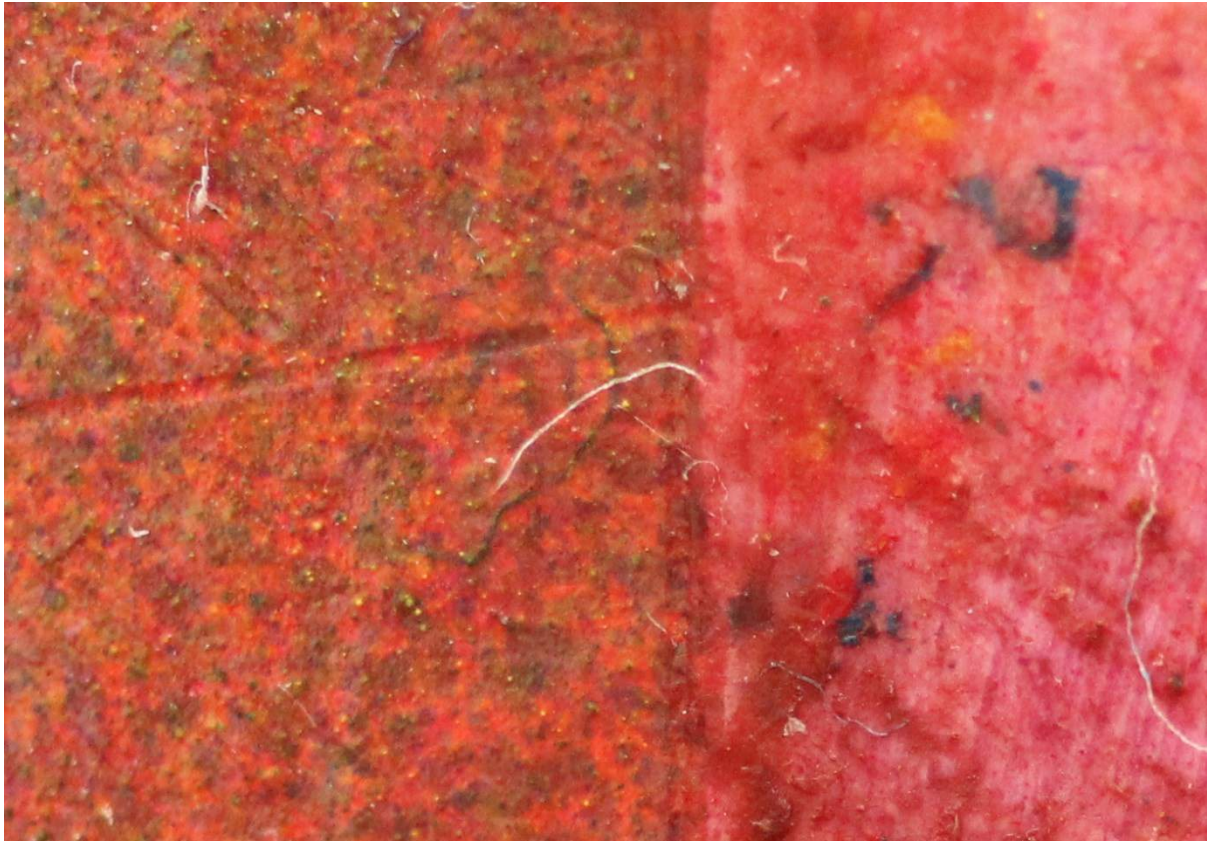

Figure 83: a close-up image shows greater detail of the airbrushed surface of the mock-up painting. The left side of the image shows the detailed network of ultra-fine paint dots applied by the airbrush. The right side of the image shows detail of the loss of the original paint layer that was deliberately made for testing.

7.2.2 The Use of Printed Infills for Image Reintegration

The use of printed infills for the image reintegration of paintings is a pretty uncommon method, unlike other conservation sectors such as in paper conservation. A rare treatment in this context was performed at the Tate for a painting by Richard Hamilton titled ‘*Hommage à Chrysler Corp*’ (1957). “Hamilton enlarged a photograph of a jet-propelled car’s air intake and printed it on thin ‘airmail’ photographic paper. This would have been weak when wet and photographers at Tate suspected residual halides through inadequate washing of the print had caused the fading to develop” (*Dilemmas in Contemporary Art: Richard Hamilton’s Hommage à Chrysler Corp. 1957*, no date). To overcome such an issue, the conservation team took a different approach via ink-jet printing a replacement image for the original collage imported from a recent photograph of the painting.



Figure 84: Richard Hamilton, *Hommage à Chrysler Corp*, (1957), Oil, metal foil and collage on wood, 1220 x 810 mm (courtesy of the Tate Gallery) “Painting after treatment with the artist’s guide print”

For experimenting with printed infills for the mock-up painting, self-adhesive material was used. The material is traded under a general name: ‘temporary inkjet tattoo paper’. Obvious from its name, the material is originally intended for the preparation of customised tattoos for the users, made by printing them out on the material via an inkjet printer. The material comes in the form of A4 paper to facilitate the printing process with common inkjet printers. It consists of base paper to hold very thin self-adhesive vinyl film which can be easily peeled off it (Figure 85).

This material was used as the base for printed infills intended to compensate for areas of loss. It was hoped that this material could provide a simple and reliable solution for the image reintegration of paintings with even and smooth surfaces, such as airbrush paintings.

Initial printing tests done on this material was supported by Northumbria University’s Graphics Department. An Epson A3 scanner was used to create high resolution images of parts of the mock-up painting where the areas of loss exist. Scanning was done before and after creating losses. Scanned images were then used as reference and to be printed and cut to perform as compensating, colour-matching, infills. The outcome was somewhat encouraging to do further testing, but not at all satisfactory (Figure 86). More printing and compensating tests followed. More areas of loss were created to facilitate those tests. However, none of those tests led to satisfactory outcomes in terms of imitative image reintegration (Figure 87). The reversibility of the material was also a problem.

7.2.2.1 *Problems found with this method*

This method, and particularly with this material used, proved not as simple or easy as was initially thought. Extensive trial and error was the only way to determine a reasonable, but still not perfect, colour matching. Errors can result from a large array of possibilities, starting from the digital photo-editing, the printing process, cutting out the infill, placing it within the area of loss and finally the removal of the infill. Results were never, as far as the researcher tried, satisfactory. The difficulty of the removal of this material from the painting poses great concerns over its reversibility. In addition, the archival quality of this material would require rigorous assessment.



Figure 85: peeling off 'temporary inkjet tattoo paper'

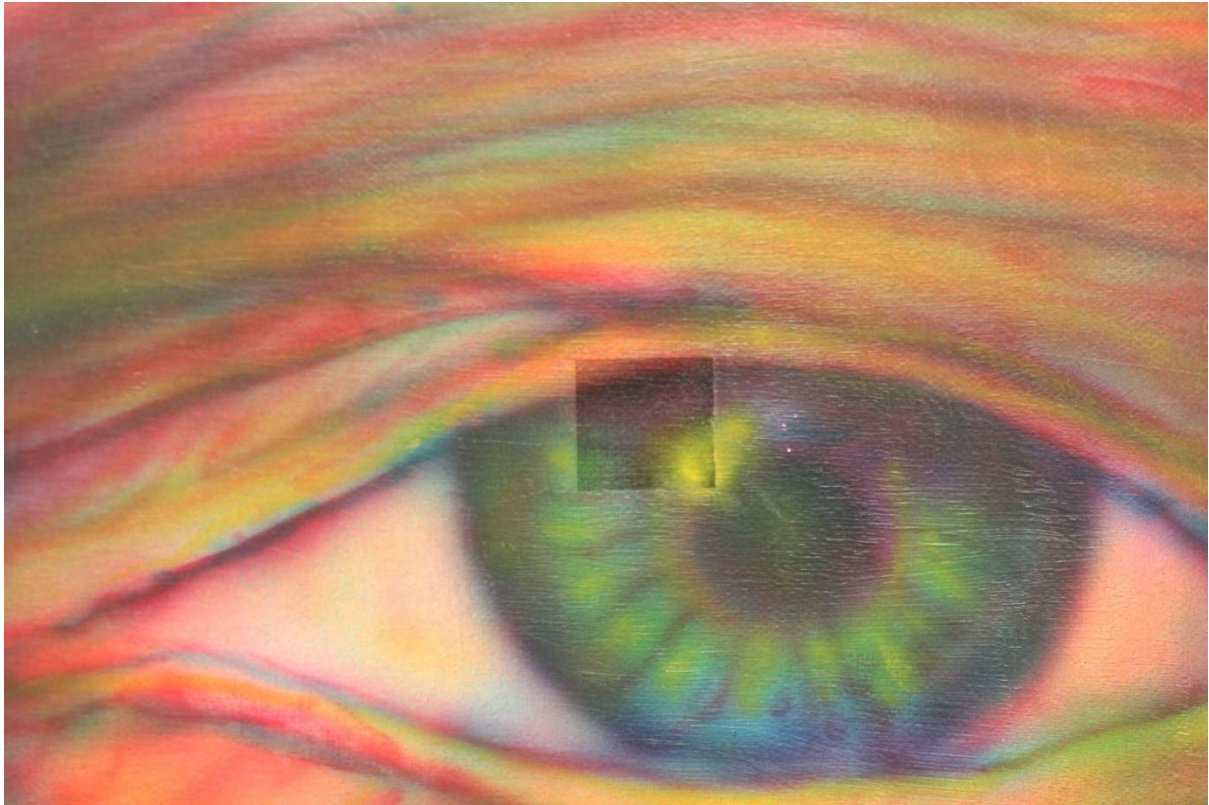

Figure 86: this is the outcome of the first image reintegration test that was done using the ‘temporary inkjet tattoo paper’, although the preliminary outcome was somewhat promising but not satisfactory. This printed infill matches the surrounding area only in certain light conditions.

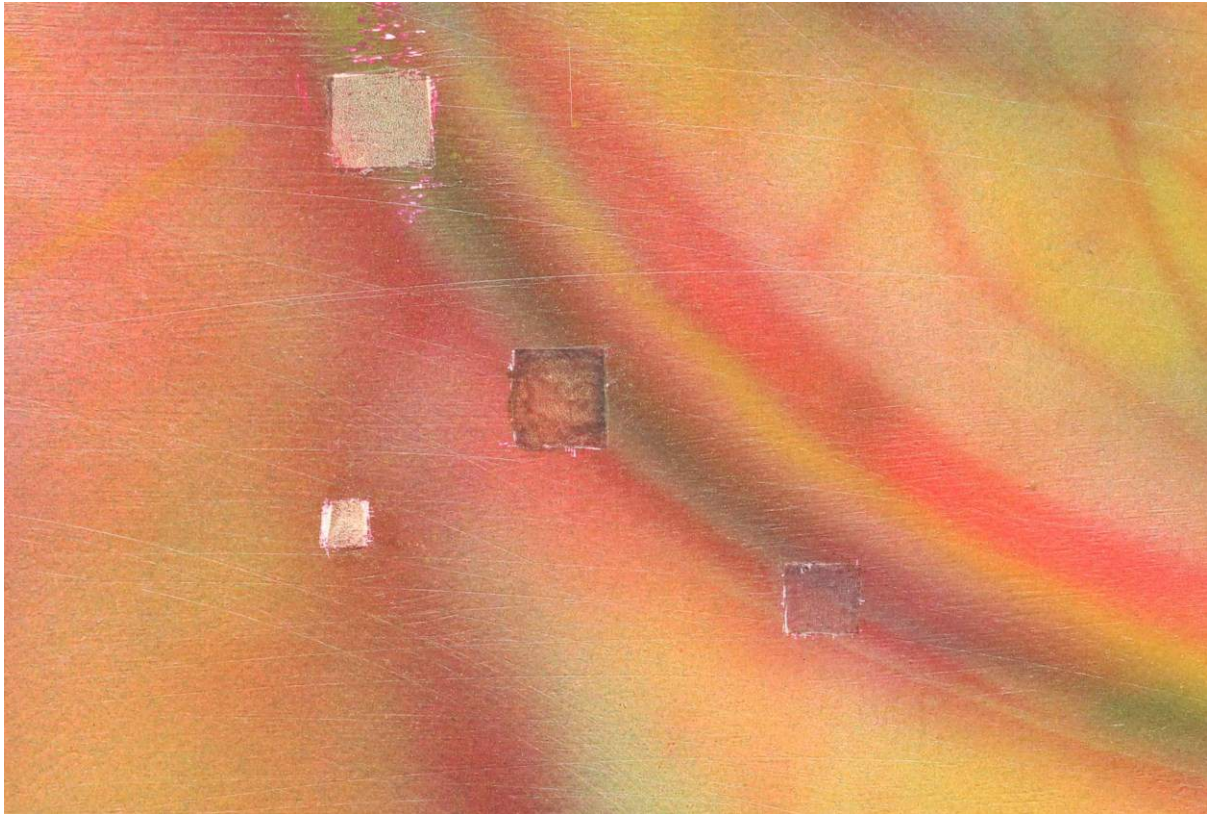

Figure 87: More areas of loss were created on the mock-up painting to facilitate image reintegration tests using printed infills. However, none of those tests led to satisfactory outcomes. The printed infill at the bottom right as viewed in this photograph is relatively the best achieved outcome in terms of colour matching; however it was greatly difficult to find a suitable method to create a cut seamless with the peripheries of the area of loss.

7.2.3 The Use of the Airbrush for Image Reintegration

Despite it seems, *prima facie*, thinkable to use the airbrush for the image reintegration of an airbrush painting, this method was deemed impractical. There are two ways to use the airbrush; freehand or with the aid of stencils. The former is absolutely uncontrollable because the sprayed paint can easily exceed the limits of the lacunae to the surrounding original paint surface. This is obviously an unethical procedure as it ignores the concept of minimal intervention and affects the integrity of the painting. The use of stencils is also not a solution. On the one hand, if the damaged area is in the form of fine scratches or similar scrapes (like in the case of the aforementioned mock-up painting) it is impossible to cut out a stencil in such a delicate shape. On the other hand, stencils create sharp edges of the sprayed paint along the perimeter of the lacuna. Accordingly, the latter would not conform to the surrounding surface.

7.2.4 The Use of Light Projectors for Virtual Image Reintegration

“Hi-tech is not a value in itself. It is only valuable if it is useful for conservation, and, in the end, for the people for whom conservation is performed.” (Muñoz Viñas, 2005, p. 203)

As shown in chapter four, there have been a few virtual image reintegration applications for artworks in general, and even fewer similar applications on easel paintings in particular, that already have been tried. Those treatments mainly depend on light projectors to virtually compensate for losses on the surface of a painting, or any object in general. In the example of Mark Rothko’s *Harvard Murals*, a projector⁶⁵ was used to compensate for colour fading on a two-dimensional substrate, while in the example of the Broemserhof ceiling murals a projector was used to compensate for a total loss on a three-dimensional substrate. Other equipment was, of course, essential for those projects, such as the computers and the software by which the final projected images were digitally prepared. Reference images were also important to properly complete missing or faded parts of the artworks in addition to fulfil the ethical requirement of the artist’s intension that could be concluded from documented photographs and/or recorded information about the material and techniques used by the artist or in the artworks concerned. An earlier account described the use of a, now old-fashioned, slide projector in order to “see through a yellow varnish prior to any cleaning” (Lafontaine, 1986, p. 97). However, the great advances of the technology of producing modern projectors added various advantages that could make them feasible to be employed in the conservation of fine art.

7.2.5 The Main Types of Projectors Currently⁶⁶ Marketed

Prior to talking about the actual application of projection that was done during this study, it would be beneficial to provide a summary of information about the main types of projectors that are available for consumers, along with the pros and cons of each type relevant to the subject of this research. There are four main types of projectors currently in the market; CRT, LCD, DLP and LCoS.

⁶⁵ The projector model used to virtually compensate fading colour in Rothko’s *Harvard Murals* is Optoma TX1080 which is a DLP projector which incorporates a UHP lamp with a service life that last between 2000-3000 hours only and costs around £200. In the next sections of this chapter more detail are given about projector types. The ability of technological advances to now offer projection solutions that would be considered better than that model used for Rothko’s paintings is also demonstrated.

⁶⁶ As of the year 2015

7.2.5.1 CRT Projectors

According to Fuchs, Moreau and Guitton (2011, p. 224) CRT (Cathode Ray Tube) projectors are the earliest. This type of projectors uses “three cathode tubes, one for each colour of the additive synthesis (red, green and blue).” The main advantage of CRT projectors is that they are capable of produce high contrast ratio⁶⁷, which with their bandwidths allows high resolutions “up to 3200 X 2560 pixels at 240 Hz in high-end products,” despite the fact that they can only produce light energy between 120 to 500 lumens. The drawbacks of CRT projectors, however, make them impractical for virtual image-reintegration in the field of painting conservation. The main problem with this type of projectors is that they are too heavy and large to be used for such a purpose due to the existence of three glass cathode tubes. The weight of those projectors could start from around 20kg and could be as heavy as 100kg (Figure 88). “Besides, the CRT projectors are subject to a deviation in their adjustment time, which requires providing for regular maintenance. Once in a month would be a good calibration frequency, which of course needs to be adjusted as the projectors’ age increases.” (Fuchs, Moreau and Guitton, 2011, p. 224). Needless to say that such a short-timed regular maintenance, along with the price of the device and replacement parts, can be costly and cumbersome over time. In addition to this, CRT projectors are not capable of providing flexibility in terms of mobility and positioning due to their weight and size, which is particularly disadvantageous because it is a must for the projected image to precisely match the missing or faded parts in the paint layer of the painting.



Figure 88: a CRT projector during installation (Kennis Russell, 2014)

7.2.5.2 LCD Projectors

LCD (Liquid Crystal Display) projectors were introduced in the early 1970s (Peter H. Putman, 2010, p. 2). This type of projector uses one final path to transmit three primary colours together in one beam. White light first comes from a dedicated lamp in the rear of the projector (typically a high

⁶⁷ “The contrast of any display system is defined as the ratio of the transmission of the bright state (high transmission) to that of the dark state (low or zero transmission).” (Yeh and Gu, 2010, p. 299)

intensity discharge lamp)⁶⁸. That light then passes onto dedicated small mirrors, called ‘dichroic mirrors’, angled in certain positions. Each dichroic mirror is coated with “thin film that reflects only light of a specific wavelength”⁶⁹ on a corresponding one of three LCD panels. Those LCD panels then transmit the colours into a dedicated prism, called dichroic prism, which then “divides light into red, green, and blue, to form three pictures that utilize these corresponding colors from the LCD panels”⁷⁰ (Figure 89). To refer to this specific technology of using three LCD panels developed and owned by the Japanese company Epson[®], LCD projectors are often traded as 3LCD.

This newer technology gives LCD projectors one of its main advantages over their predecessors; the CRTs, as no regular adjustments are required by the user to precisely merge the three colour beams. The much less weight and the much higher luminous power (2000 to 5000 lumens) of LCD projectors than those of CRTs add to the advantages of the former. However, “the main disadvantage of the LCD video projectors is that the images are shown with rectangular pixels which display spaces between them, which in turn degrades the image quality” (Fuchs, Moreau and Guitton, 2011, p. 224). The average market price of LCD projectors is less expensive than that of CRT projectors which could be another advantage. However, the service life of LCD projectors’ lamps is short. They could last in an average up to only 3000 hours (and even in certain conditions) according to marketing information of many well-known brands. That means that those lamps are highly likely to require replacement every year at maximum. The main issue with this obligatory regular replacement is the prices of those lamps, as they start at around £100, for the cheapest third party lamps, up to several hundreds Pounds, if official first party lamps are required. That can be an outstanding running cost, particularly if we learnt that the projector would only serve for one painting. LED lamps, however, would have been a better solution for 3LCD-technology-based projectors. Regardless, there were a few trials to launch 3LCD LED projectors, but apparently with no long-term success⁷¹. LED lamps were best suited in

⁶⁸ “The two major lamp types used for light-valve and microdisplay projection systems are tungsten-halogen lamps and high intensity discharge (HID) lamps, which include xenon lamps, metal-halide lamps, and ultra-high pressure (UHP) mercury lamps... Tungsten-halogen lamps are generally only used in low performance projectors” (Brennesholtz and Stupp, 2008, p. 169). There is of course a third type of projector lamps; LED, which is currently, as of the year 2015, finding its way through the projectors’ market, as shall be discussed shortly in this chapter.

⁶⁹ http://3lcd.com/explore/dichroic_mirror.aspx

⁷⁰ *Ibid.*

⁷¹ Such like Samsung F10M the “world’s first 3LCD LED projector” announced on 2nd June 2010 by 3LCD.com (http://www.3lcd.com/news/press_release.aspx?bot=true&release_id=344). The F10M was then discontinued, and no other LED 3LCD-based projectors can be found now in the market, presumably because of the introduction of LED single-chip DLP-based projectors that combined the both worlds of extremely light-

DLP Pico projectors, and significantly contributed to the weight of such devices (as will be discussed in the next section of this chapter). Although LCD projectors are definitely much lighter in weight and smaller in size than CRT projectors, they do not match the even lighter and smaller Pico projectors, even with PowerLite 3LCD Projector produced by Epson®, which is claimed as an “ultraportable” projector (Figure 90).

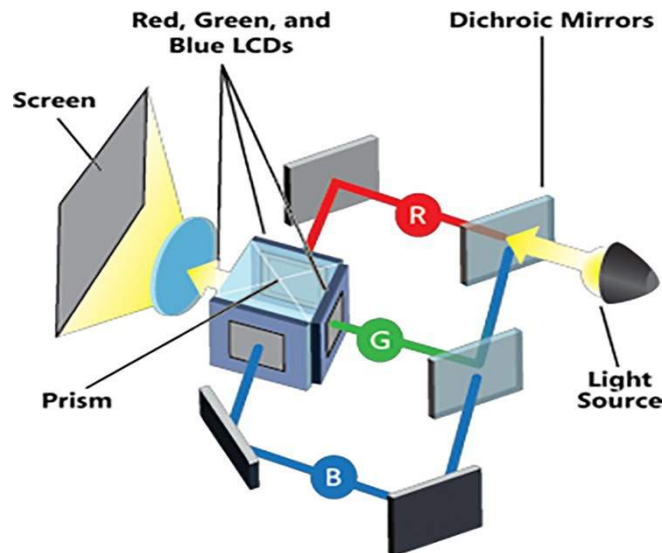

Figure 89: schematic drawing of LCD projector components (3LCD.com)



Figure 90: Epson® PowerLite 1761W WXGA 3LCD Projector (Mark Watson, 2013)

7.2.5.3 DLP Projectors

DLP (Digital Light Processing) projectors are based on a technology “invented in 1987 by Larry Hornbeck of Texas Instruments” (Ivergard and Hunt, 2008, p. 112). DLP technology use a DMD (Digital Micromirror Device) chip⁷² that incorporates an array of thousands of aluminium micro-mirrors (1 micron each), “where each mirror corresponds to one pixel to be displayed” (Fuchs,

weight devices and economical maintenance besides other advantages that shall be shortly discussed under ‘DLP Projectors’ section in this chapter.

⁷² High-end, and accordingly most expensive, 3-chip DLP projectors use three DMD chips, each chip is dedicated to one of the three RGB primary colours.

Moreau and Guitton, 2011, p. 225). Those micro-mirrors are individually moveable so they can reflect “more or less light by temporal modulation” (*Ibid.*) and accordingly create up to “1024 shades of grey to convert the video or graphic signal entering the DLP chip into a highly-detailed greyscale image” (Ivergard and Hunt, 2008, p. 112). White light is first projected from a rear lamp, and then transmitted into a ‘colour wheel’ positioned between two focusing optical lenses and divided into sections that represent the three primary RGB colours, creating a sequential colour system. The sequential colour beams are then shone onto a DMD chip (or onto three DMD chips in high-end DLP projectors). The DMD chip finally passes coordinated pixels, which correspond to the original graphical input, into a projection lens (Figure 91).

DLP projectors have several advantages including being lightweight compared to LCD projectors in general, mainly because of the existence of the small micromirrors chip instead of the dichroic prism. DLP projectors also generally produce better luminous power and higher contrast ratios (Ivergard and Hunt, 2008, p. 114). Images projected by DLP projectors are not susceptible to a phenomenon called image retention (also called ghost images, image latent, image sticking and burn-ins) resulting from degradation in luminosity of light-emitting pixels (Boer, 2011, p. 135). Another phenomenon, known for being associated with LCD projection systems, is called the ‘screen door effect’ “because it appears as though the picture is being viewed through a screen door” (Limited and Esl, 2004, p. 220). The latter phenomenon is not found in DLP projectors, which is considered another important advantage (Ivergard and Hunt, 2008, p. 114).

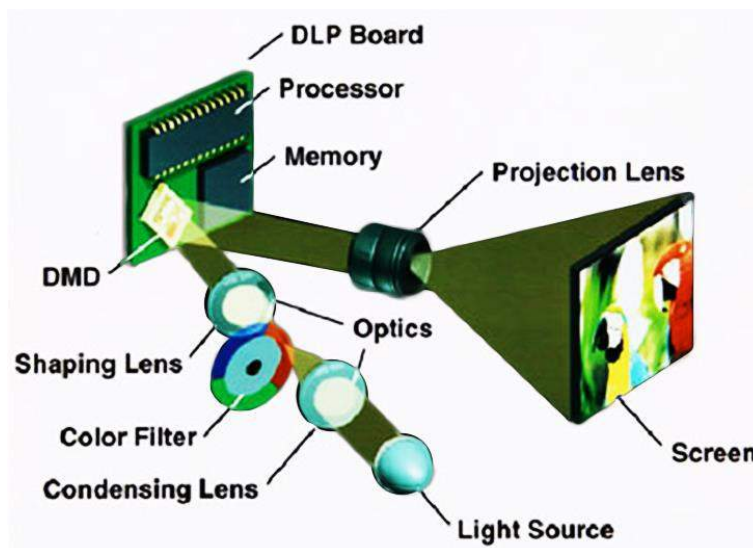

Figure 91: schematic drawing of DLP projector components (Texas Instruments: ti.com)

7.2.5.3.1 DLP Pico Projectors

Also known as pocket projectors and mobile projectors, as the name suggests this is the main advantage of this type of projectors: being small and light to the extent that it can be easily handheld

or even put in a pocket like any smartphone (Figure 92). In fact, Pico projectors can even be a built-in feature inside a smartphone device, such as the now-discontinued Samsung i8530 Galaxy Beam. Thanks to incorporating LED lamps instead of the older HID or UHP lamps, manufacturers were able to significantly reduce the size and weight of DLP projectors. Not only HID or UHP lamps contribute to the size and weight of projectors, but also other essential accessories, such as lamp housings, heat sinks and fans that are necessary to control thermal emissions coming from such lamps.

LED (Light-Emitting Diode) lamps are also known for being energy-efficient and use much less power (watts) per unit of light generated (lumens) compared to other projector lamps. This gave an opportunity for several projectors manufacturers to make battery-powered Pico projectors, which in turn provides even more mobility to those projectors. Moreover, in terms of UV-sensitive materials, there are museums that already installed LED lamps as light sources for their collections⁷³. The longevity of LED lamps' service-life, which is incomparable to older projector lamps, make them even more advantageous as there is no need for mandatory short-timed regular maintenance, and accordingly regular running costs. LED projectors are often claimed to last up to 20,000 hours, which is ten times more than the service life of most marketed projectors based on HID or UHP lamps.

Apart from LED, there have been fewer Pico projectors introduced to the marketplace based on laser lighting technology, such as Microvision ShowWX projectors that incorporate technology developed by Microvision, Inc. called PicoP[®]. However, almost all of the projectors of this type are discontinued at the moment for unknown reasons. In February 2014, Both Microvision, Inc. and Sony Corporation announced “the development of a Pico projector module equipped with Sony's independently-developed image processing system, that uses laser beam scanning (LBS)... and incorporates a semiconductor laser as the source of light.”⁷⁴ Sony, however, have not introduced any final products with such a technology to end-users as yet. Both laser Pico projectors produced by Microvision and those announced by Sony incorporate MEMS (Micro Electro Mechanical Systems) mirror patented by Microvision, instead of DMD chips incorporated in DLP projectors. One of the main announced advantages of laser projectors in general is that they are focus-free, which means for the users that there would be no need to manually focus the projection lens, “regardless of the distance or angle from the projection surface.” It is worth noting that laser Pico projectors do not currently exist in the marketplace, but that could, of course, positively change in the future.

⁷³ As claimed by some LED leading manufactures, such as OSRAM, LED lamps produce “low UV radiation and minimal infrared radiation” (http://www.osram-os.com/osram_os/en/news--events/spotlights/success-stories/2013/true-art-led-lighting-in-museums/index.jsp). There are museums that already installed lighting systems that depend on LED lamps (Ledtronics, 2010, p. 15) & (Cuttle, 2007, p. 209).

⁷⁴ <http://www.sony.net/SonyInfo/News/Press/201402/14-024E/>

Pico projectors are also inexpensive. The average price of DLP Pico projectors is around £300 for well-known brands with good specifications, and even cheaper prices (less than £100) can be easily found. That, combined with near-zero running costs (again, thanks to the long-life LED lamps), gives Pico projectors an added advantage over other types of projectors.

The main, and probably the only, shortcoming of Pico projectors is the low luminous power because of the limited ability of LEDs to produce as high amount of lumens as UHP lamps or other older projection lamps. It is believed that the maximum luminous power that a LED-based DLP projector can reach is 2000 lumens (Brennesholtz and Stupp, 2008, p. 190), which is apparently incomparable with higher 20,000 and above lumens in average UHP-based DLP projectors. . However, it was found during the experimental work in this research that LED DLP projectors, even at much lower amounts of lumens outputs, are capable of performing good virtual image-reintegration quality, as will be further discussed in the relevant section of this chapter.



Figure 92: an example of a Pico projector (Proulx, 2012, p. 386)

7.2.5.4 LCoS Projectors

The LCOS (Liquid Crystal on Silicon) projectors are considered a hybrid that combines both the LCD and DLP technologies. Those projectors usually use three chips like high-end DLP projectors (Fuchs, Moreau and Guitton, 2011, p. 225). LCoS projectors are very good performers, however they are greatly expensive, with prices that start from around £2000 up to over £10,000. They are also generally heavier than DLP projectors.

7.2.5.5 Specifications to look for in a Pico projector for virtual image-reintegration:

Although Pico projectors offer incomparable mobility due to their small size and lightweight⁷⁵, there are other specifications that are important to look for prior to purchasing one of those projectors to tackle an actual virtual image-reintegration application.

7.2.5.5.1 Resolution options

Projectors that use micro-display technologies, i.e. LCD, DLP or LCoS chips, always have a fixed number of pixels. That fixed number is called ‘native resolution’, and it is always mentioned among the specifications of any projector. ‘Native resolution’ should not be confused with the ‘maximum resolution’ (also called ‘computer compatibility’), which is also usually mentioned in the specification list. The latter is meant to be the maximum resolution of a source device (e.g. computer) recognised by the connected projector and not produced by it. For example, a Samsung SP-H03 can recognise computer signals up to 1280 x 720, but it would not be able to project an image of more than 854 x 480, which is its optimum native resolution. Native resolution number is thus important to be noted because it indicates the maximum quality of the final projected image that could be obtained, and of course the higher the resolution numbers the better the image quality.

There are standard resolution acronyms that correspond to maximum resolution numbers, of vertical pixels multiplying horizontal pixels that a projection system can produce, as in the following list (Andrews, 2009, p. 384):

- VGA (Video Graphics Array) supports up to 640 x 480
- SVGA (Super VGA) supports up to 800 x 600
- XGA (Extended Graphics Array) supports up to 1024 x 768
- SXGA (Super XGA) supports up to 1280 x 1024
- SXGA+ is a variation of SXGA and uses a resolution of 1400 x 1050
- WSXGA+ (Wide SXGA+) uses a resolution of 1680 x 1050
- UXGA (Ultra XGA) supports up to 1600 x 1200
- WUXGA (Wide UXGA) supports up to 1920 x 1200
- QWXGA (Quad Wide XGA) supports up to 2048 x 1152
- WQXGA (Wide Quad XGA) supports up to 2560 x 1600

⁷⁵ Smaller Pico projectors like Acer C20, Aiptek PocketCinema Q20, Philips Picopix PPX2330 and Samsung SP-H03 weigh less than 300g with sizes similar to that of an average-size smartphone. Larger Pico projectors like Asus S1, Optoma ML750 and Acer K130 weigh between 300-400g with sizes that lie between an average-size smartphone and a 7” tablet.

7.2.5.5.2 Brightness

The maximum luminous power a projector claimed to produce, and it is expressed as a number of lumens. The higher the number of lumens the brighter the image projected. Pico projectors with higher brightness tend to be more expensive. The highest luminous power number that could be found in market at the moment is 1000 lumens (such as with Acer K335 model). As will be discussed in the experimental section of this chapter, it was however found that it is not necessary, or even beneficial, to obtain a Pico projector with more than 300 lumens, if it is intended to be used for virtual image-reintegration.

7.2.5.5.3 Contrast ratio

Contrast ratio indicates the maximum difference between blacks and whites a projector can handle. It is particularly important to choose a projector with a higher contrast ratio. At the moment, the maximum contrast ratio offered by Pico projectors is 10,000:1 (as with Acer k130 model). In general, the higher the contrast ratio the better subtle tonal differences would appear, especially if ambient light is required.

7.2.5.5.4 Keystone Correction

That is a feature adopted by many branded projectors, including of course Pico projectors. Keystone correction feature enables the projector to automatically correct the projected image if distorted as a result of the position of the projector not being perpendicular to the projection substrate (Figure 93). If a projector is required for a virtual image-reintegration application, then that feature is essential, because it is highly likely that the projector would not be positioned perpendicularly with the treated painting.

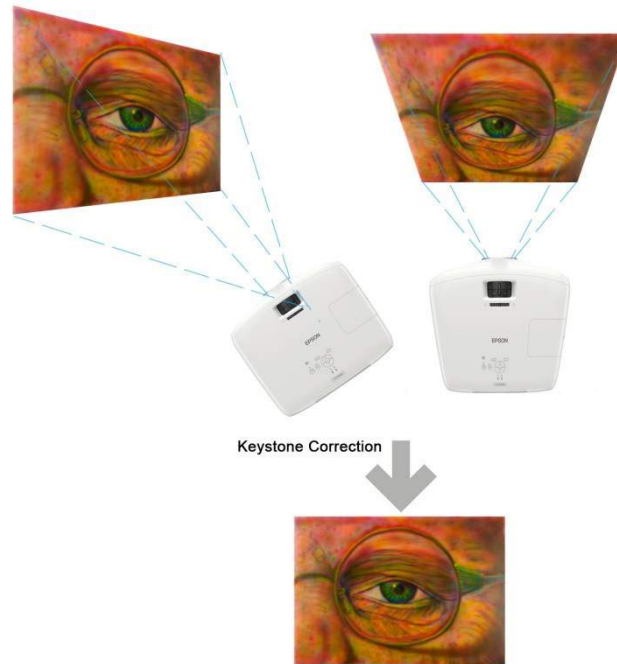

Figure 93: a tilted and/or angled projector caused distortions in the projected image. This problem is known as ‘keystoning’. In order to overcome this problem, many of the modern projectors can automatically correct such distortions.

7.2.5.5.5 Interface and power options

For further mobility, it is particularly useful to choose a projector that offers internal memory and/or useful inputs like a SD card slot and USB (Universal Serial Bus) connections into which a memory stick could be plugged in. Such options would eliminate the requirement of connecting the projector to a computer. Thus in case of virtual image-reintegration, the digital image to be projected on a painting could accompany the projector via an internal, or a plugged-in external memory medium.

Several Pico projectors models could be powered by batteries (usually rechargeable lithium ion batteries) that provide a limited time of power (60 minutes on average) to the device. Larger Pico projectors, like Acer K130 and the likes, are powered only through mains electricity, which accordingly reduces mobility.

In addition to the aforesaid options, it is a plus for a projector to be equipped with user-friendly software which can handle several digital image formats, including JPG, PNG and TIFF formats. A remote control would be beneficial if the projector is to be hanged from a ceiling, and also to avoid causing movements in the projector by using its built-in buttons, which could affect the virtual image-reintegrating projection. Also important to notice, is the minimum and maximum projection distance that the projector can handle. Besides, the minimum and maximum diagonal projected image size which could affect a projector’s ability to cover larger paintings. There also are options that could be

looked over but are worth noting, e.g. if there is a fan and how much noise (in dB units) it produces, if there is a standard tripod screw thread if the projector is required to be mounted on a tripod and if the focus of the projection lens is automatically or manually adjusted.

7.2.6 The Use of a DLP Pico-Projector for the Image-Reintegration of the Mock-Up Painting

7.2.6.1.1 The projector

For carrying out virtual image-reintegration for the mock-up painting, an Acer K130 projector was bought (Figure 94). That is a portable Pico LED DLP projector type (430g, 14 cm x 11.6 cm x 4.1 cm), which is capable to produce up to 300 ANSI⁷⁶ lumens and 10,000:1 contrast ratio. The native resolution of this projector is 1280 x 800 (WXGA) and can recognise a maximum resolution of 1920 x 1080. The projector incorporates auto ± 40 keystone correction and can handle a projection distance between 0.97 m - 2.58 m. It does not have an internal memory, but it has a USB connection and a micro SD card slot. It could be powered from the mains only. With regard to digital picture formats, Acer K130 is capable to only recognise JPG and BMP file extensions. Newer Acer models of this type are now distributed, so this specific model K130 is now discontinued. However, it could be still be found in the marketplace for around £300.



Figure 94: the Acer K130 projector used for the virtual image-reintegration experimental carried out for the mock-up painting. For that purpose, the projector was mounted on a tripod to facilitate the necessary adjustments of the image projected.

⁷⁶ Projectors datasheets and specification lists often use the acronym ANSI with the lumen unit to point out to a standard lumen, as the acronym refer to the American National Standards Institute (ANSI).

7.2.6.1.2 Preparation of the virtual compensating image

Similar photo-editing preparation for compensating infills was followed and presented in this section with more detail. A reference digital picture of the mock-up painting prior to damage was used as a source for the image intended for virtual image-reintegration. All of the digital pictures were processed from RAW Canon file format into TIFF (Tagged Image File Format) to maintain original image quality. Adobe® Photoshop® CC was the editing software used for processing and editing all digital pictures used in this experimental. The researcher developed good knowledge with Adobe Photoshop over several years of effective use. This enabled him to personally utilise the software for this project.

Using high-resolution reference digital image taken for the mock-up painting before damage, it was relatively easy with the use of Adobe Photoshop to subtract the contour of the area of loss with only the places where losses occurred. Even the tiniest hairline-like places of loss were relatively easy to be subtracted and processed in reasonable and manageable steps (Figure 95). The damaged painting was placed as a layer over the original and used to make in-selectin of losses. An image of the ‘losses lines’, now filled-in with original corresponding colour, was placed as a new layer over a transparent background (Figure 96). The layer was then saves as a PSD file (to maintain later possible workability with Photoshop) and PNG (to maintain transparency as an independent picture file).

Since the Acer K130 projector only support JPG and BMP files, the PNG file was then converted into JPGs. Brightness of the colours in the compensating image was increased and decreased with incremental of 10 of the brightness value given by Photoshop. 21 images were accordingly created that represent brightest to darkest values available in the software. The latter procedure was performed in order to have as many images with different brightness degrees as reasonably possible, so they can be selected from to cope with slight differentiations between the virtual compensating image and the surrounding colours. The images were then saved in a micro SD card to be read by the projector. The projector was then used to project the compensating image into its place of the loss area (Figure 97). It was relatively easy to align using the built-in digital projector grid alignment; however this was not a straightforward procedure, and several adjustments to the position of the projector were made.

The projected image provided promising visual results. The matching was not perfect, however further adjustment is possible. It was also found that the use of scanning, rather than photographing the painting, provides much more reliable visual information. It also facilitates better alignment at later stages because photographing often causes distortions on the far sides of the paintings (barrel effect), and while this can be easily fixed by Photoshop, it is highly likely to change the corresponding

dimensions in the photograph, and accordingly cause problems during the preparation of the virtual compensating image. There was a much safer, easier and faster outcome than any other known image reintegration method. It was found that the projected image works fine with the normal ambient light. The ambient light was measured by a digital light meter and the results were found similar to that recommended for museum displays.

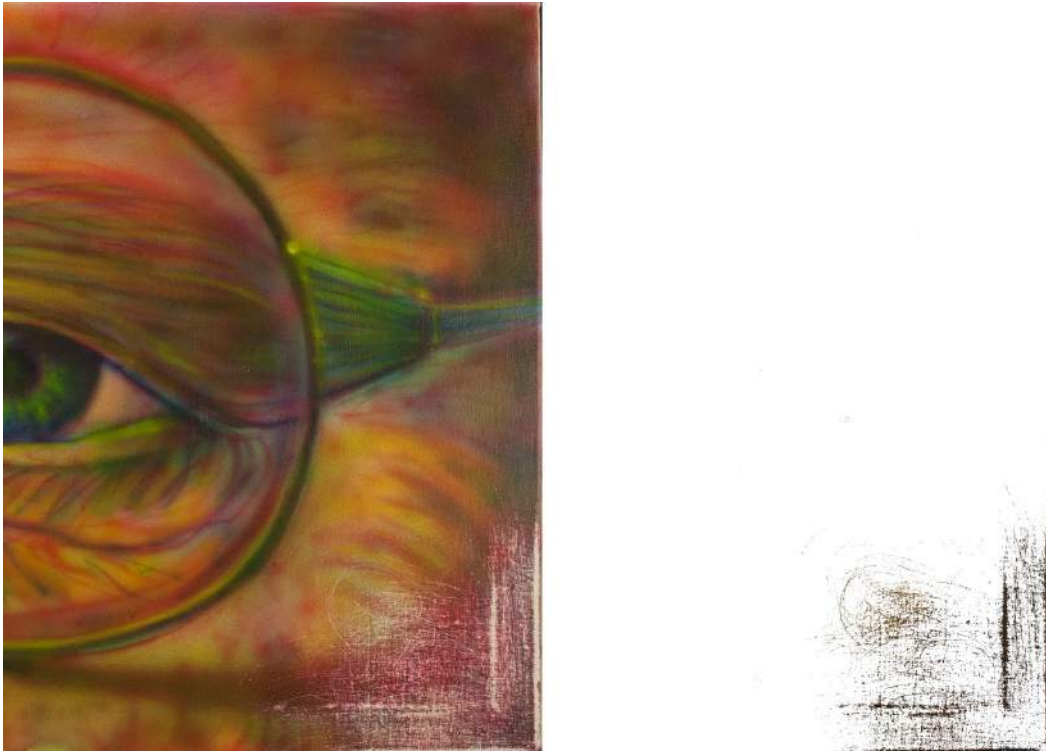

Figure 95: (left) the right part of the mock-painting where the area of loss is present, (right) the compensating digital image that was cut out, using photo-editing software, from a high-resolution reference digital image of the mock-up painting before being damaged.

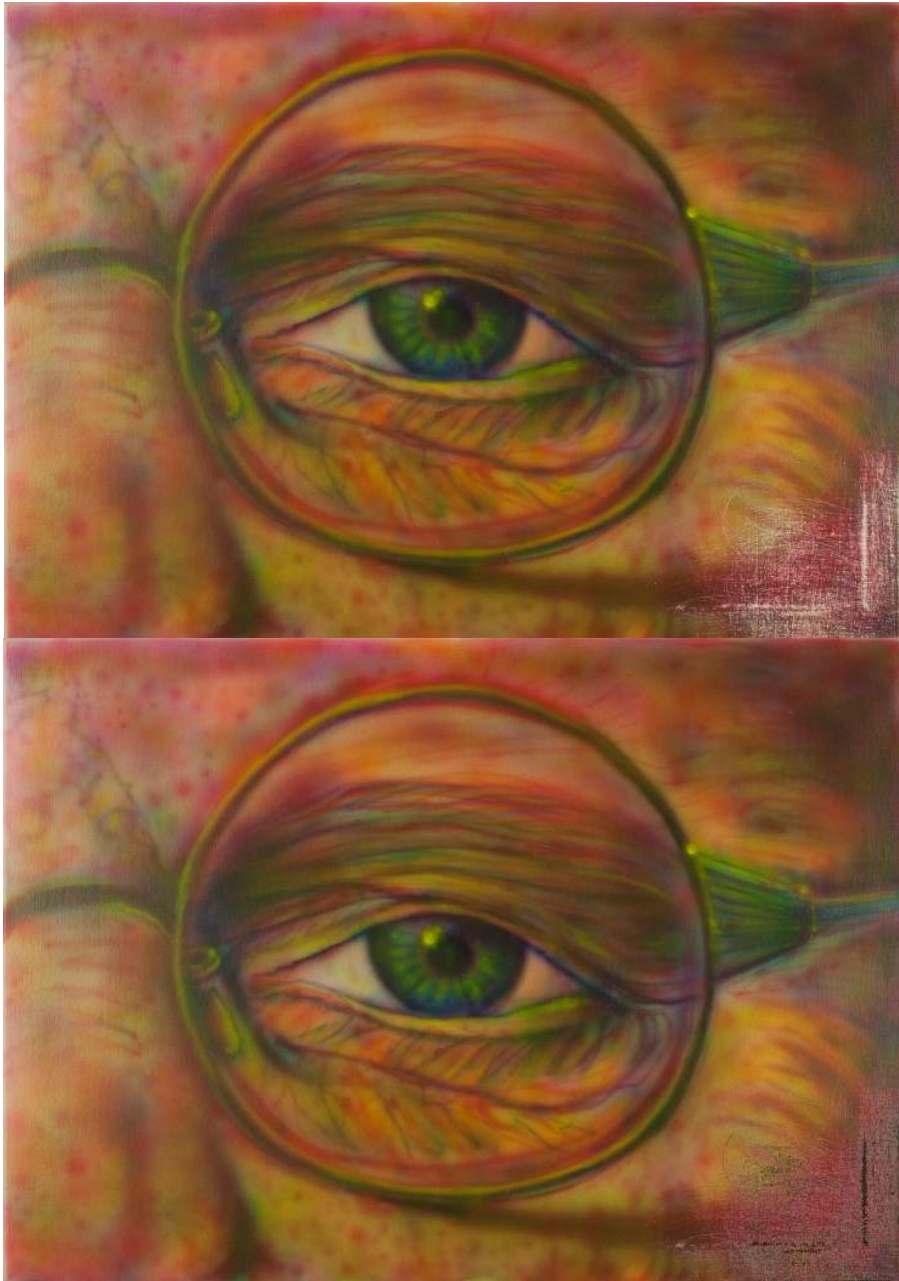

Figure 96: (above) the mock-up painting with damage present at the bottom right corner, (bottom) the compensating image was placed digitally to represent its appearance by a projector

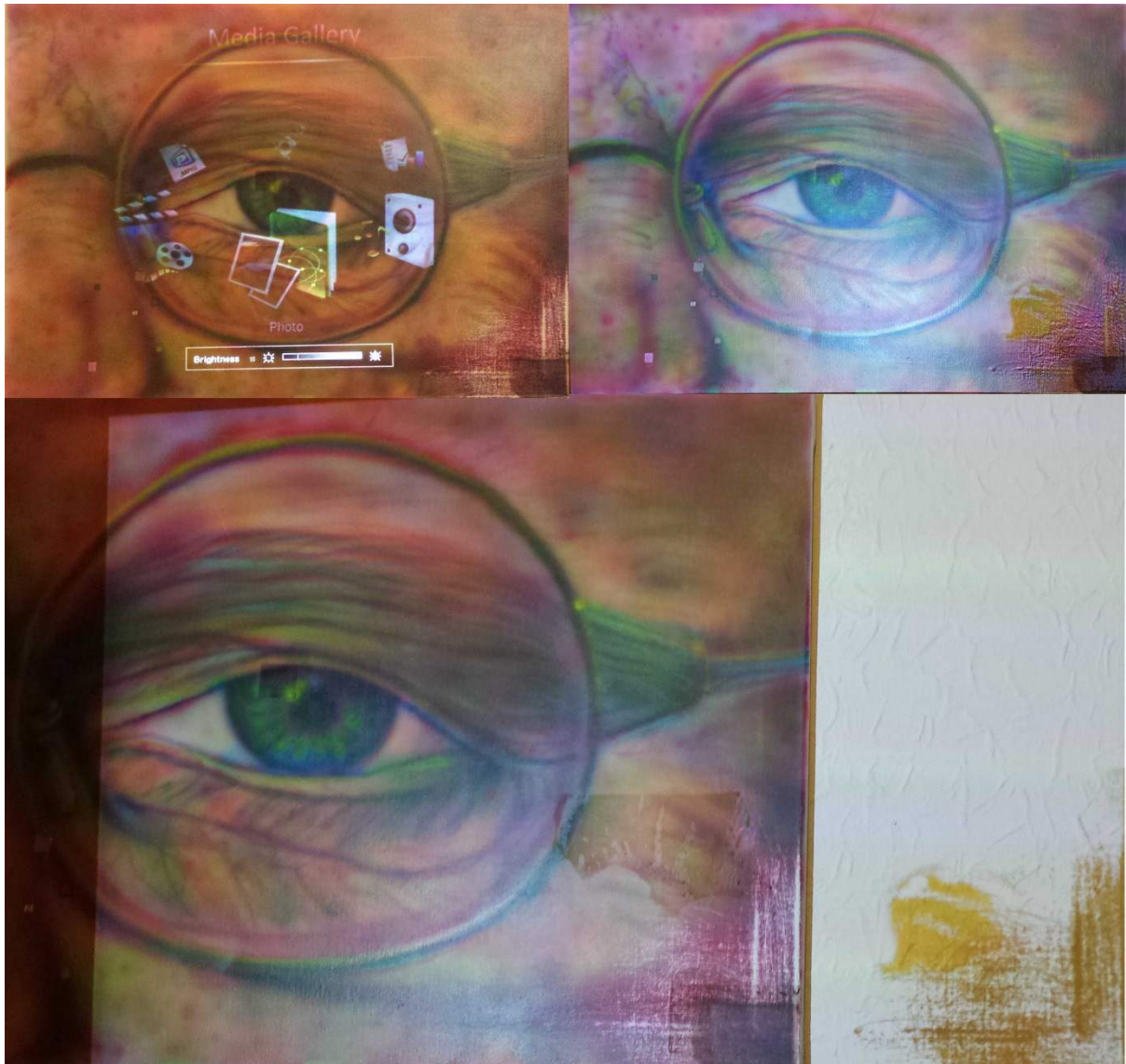

Figure 97: a number of photo shots of the projection of the compensating image prepared for the virtual non-interventive image reintegration performed for mock-up painting

7.2.7 Conclusion

The present chapter demonstrated different approaches of image reintegration treatments tested using a mock-up painting. Interventive approaches were undertaken using the traditional method of imitative retouching with brushes and with printed infills. The non-interventive approach using a LED Pico projector was investigated. Missing areas of the paint surface of the mock-up painting were compensated using a projected digital image of the original areas. The latter approach proved advantageous and provided a better solution for the image reintegration treatment of airbrush paintings. The next final chapter offers a summary of the findings and outcomes of the thesis.

Chapter 8: Discussion, Conclusions and Recommendations

8.1 Discussion

A combination of results and findings achieved via the mixed qualitative and quantitative methodology followed in this study. In terms of the context of the history of airbrush in relation to fine art painting literature review indicates that the airbrush took around 70 years, since it was first introduced to the market, until it became one of the essential art tools used by many fine artists, rather than being only labelled as a ‘commercial’ tool used for illustrations and photographic editing. The number of fine artists who rely on this tool could even increase in the future according art styles that have popularity, such as the Photorealism.

Questionnaires’ results indicate that there is a considerable percentage of uncertainty by the surveyed practitioners in the field of paintings conservation with regard to the existence of established knowledge about problems that might be directly related to airbrush paintings. About 87% of the art conservators responded to the questionnaire are unsure if there are safe treatments for airbrush paintings. This is an important finding particularly when accompanied with approximately 78% of those who already have direct contact with the treatment of airbrush paintings, and agree that conservation problems in airbrush paintings are different from those in paintings executed with other paint application types.

On the other hand, practical trials of conventional treatments on a mock-up show limited capabilities of treating several forms of damage to the delicate paint surface of airbrush paintings. Alternatively the use of digital means suggested in this study gave better and safer image reintegration solutions. The use of Pico projectors provided even more facilitation to the non-interventive image reintegration, or virtual retouching, of the damaged mock-up painting. That is due to more than one factor, more importantly low immediate cost, near-to-zero running costs and the exceptionally light weight and small size of the Pico projectors. However, it would be understandable that, in the foreseen future, such an unconventional ‘treatment’ might encounter difficulties to be effectively put into practice by many conservation practitioners, along with a myriad of many others involved, such as art collectors, curators, galleries’ owners, museums’ directors, etc.

8.2 Conclusions

A literature review of the history of the airbrush in the context of fine art made clear that the airbrush has been, for a long time, a neglected (or avoided) tool by fine artists when comes to executing paintings, and not illustration or graphic designs. It was also found that the airbrush became

effectively more popular in fine art from around the 1950's, particularly with the help of some modern art movements and styles like the Pop Art and Photorealism.

The outcome of the survey questionnaire supports the preliminary hypothesis that easel paintings executed solely or mainly using airbrushing can be problematic in terms of conservation treatment. Results from accelerated ageing tests and concurrent spectrophotometry examinations indicate higher sensitivity against light in airbrushed paint surfaces compared to those executed by paint-brushing. Conventional treatments do not serve well in terms of tackling problems that could occur on the paint layer of airbrush paintings. 'Unconventional' treatments suggested in this study, in particular non-interventive image reintegration using Pico projectors, could have better capabilities in this context.

8.3 Contribution to Knowledge

The findings of this research offered answers to its main questions. Those answers are backed up with the outcomes and results of the various approaches demonstrated and discussed in the present thesis; the survey, the scientific experimental (includes chemical analysis, ageing tests and SEM observations) and the investigation of different image reintegration methods. The main questions of this research were:

- Are airbrush paintings more problematic when it comes to image reintegration?
- Could there be effective, feasible and yet reversible image reintegration methods for airbrush paintings?

The outcomes of the questionnaire aimed at art conservators provided sensible information that shows a degree of uncertainty among practitioners with regard to the treatment of airbrush paintings, particularly with regard to image reintegration. This outcome contributes to the current body of knowledge in the field of art conservation by shedding light on an artistic technique which, in itself, could pose concerns about those paintings executed with.

Moreover, the results obtained from the light ageing tests combined with close observation performed using SEM show that paintings executed with airbrushing could be more susceptible to ageing effects compared to paintings executed with traditional techniques, even if the paint materials in both cases are similar.

The answer to the second question was investigated in chapter seven. Different interventive image reintegration techniques were investigated and proved impractical, problematic and/or pose concerns with regard to integrity, reversibility and longevity. The application of light projection as non-interventive image reintegration technique, investigated in chapter 7, offers more than one advantage for airbrush paintings. The current body of knowledge on the conservation of paintings shows so few

attempts in using light projection for the purpose of image reintegration of paintings in general. Furthermore, there have been no such attempts done previously with airbrush paintings. Therefore, this study adds an image reintegration solution, viable in many ways, for this particular type of painting.

Additionally, other minor contributions to knowledge were provided. Those are pertaining to the history of the airbrush. Although Penaluna's research offers thorough investigation towards such a subject, certain parts of the history were missing due to a previous lack of relevant resources. For example, historical resources contemporary to the series of events that led Walkup's company to lose its case against Thayer and Chandler's company. On this matter Penaluna states that "no evidence has been found to suggest that any legal battles or other such disputes continued between the Air Brush Manufacturing Co and Thayer and Chandler." The present research offered new evidence on this matter through primary sources.

Furthermore, a critique was given as an attempt to reach a rational organising of the confused and scattered terminology on the concept of image reintegration. Accordingly, it is now suggested that the term 'image reintegration' should be used as a collective term under which a hierarchy of relevant terms could be arranged according to their notions related to either interventive or non-interventive treatments.

8.4 Recommendations

There are still several areas that could not be covered by this research to help determine further aspects with regards to the airbrush and airbrush paintings. Further surveying, for example in the form of questionnaires and interviews, could be performed with fine artists whose associations with the airbrush are known. The researcher found it particularly difficult to locate exhibiting fine artists who are known to have worked with the airbrush. The researcher looks forward to later create a database that include established fine art painters who work, or have worked, extensively using airbrushing techniques.

Although the 'real' history of the airbrush itself has been already established by Dr Andy Penaluna in his important, and yet unpublished, PhD research, it seems that there is a wealth of information which is yet to be discovered and extracted. Only very recently, after years of Dr Penaluna's submission of his PhD, several highly important online databases dedicated to historical newspapers and periodicals have been launched. Such online databases, like those of the British Library, Library of Congress (Chronicling America) and the National Library of Australia (Trove) offered to the researcher a wealth of digitised and searchable periodicals and newspapers that were easily searchable for finding out day-to-day written and visual information of events and people which occurred more than a

century ago. There are bits of information found that could possibly add to the valuable work executed already by Dr Penaluna.

With regards to airbrush paintings, there could be further research into the impact of such a paint application, which is neglected in conservation literature as far as it is almost neglected in fine art literature. Further investigation into the environmental impact on airbrush paintings would also be recommended to be carried out. Additionally, other aspects of conservation treatments that could be particularly problematic in the case of airbrush paintings, such as cleaning, would require attention.

In summary, it is recommended that the paint surface in airbrush paintings should be looked at in a way that is different from that of 'paint-brushed' paintings, or other similar paint application methods. Ostensibly, the relatively 'young' collections of easel paintings that have been executed either partially or totally with airbrushing did not address enough issues to ignite a widespread research, as yet. Most of the oldest airbrush paintings date back to around the mid-twentieth century. However, the delicacy of the airbrushed paint layer could cause issues in the future that are probably better to undergo early investigation to find better preventive and interventive solutions. And, as the image reintegration solutions introduced in this study suggests, the great advances in digital means that we have today or will be having in the near future could provide an alternative and feasible answer to problematic issues in this context.

List of References

- Ackroyd, P. (2010) 'Retouching media used at the National Gallery, London, since the nineteenth century', in *Mixing and matching: approaches to retouching paintings*. London: Archetype, pp. 51–60.
- Aftalion, F. (1991) *A History of the International Chemical Industry*. University of Pennsylvania Press.
- Air Brush Manufacturing Company (Rockford, I. (1887) *Price List and Description of the Air Brush*. The Company. Available at: <http://books.google.co.uk/books?id=lepKtwAACAAJ> (Accessed: 29 January 2015).
- Andrews, J. P. D. (2009) *CompTIA A+ 2009 In Depth*. Cengage Learning.
- Arikawa, K. (2003) 'Spectral organization of the eye of a butterfly, *Papilio*', *Journal of Comparative Physiology A*, 189(11), pp. 791–800.
- Association, O. and C. C. (1993) *Surface Coatings: Volume 1 Raw Materials and Their Usage*. Springer Science & Business Media.
- Babbie, E. R. (1990) *Survey Research Methods*. Wadsworth Publishing Company.
- Baetjer, K. (1997) *The Jackson Pollock Sketchbooks in the Metropolitan Museum of Art*. Metropolitan Museum of Art.
- Bailão, A. (2010) 'Primeiros passos de maturidade a caminho da reintegração cromática diferenciada em pintura de cavalete em Portugal', *Ge-conservación*, 1(1), pp. 127–141.
- Bann, S. (1997) *Paul Delaroche: History Painted*. Reaktion Books.
- Bansa, H. (2002) 'Accelerated ageing of paper: some ideas on its practical benefit', *Restaurator*, 23(2), pp. 106–117.
- Barrie Cook, 'Painting' 1970 (no date) Tate. Available at: <http://www.tate.org.uk/art/artworks/cook-painting-t01576/text-catalogue-entry> (Accessed: 9 February 2015).
- Bell, D. (2004) *Ukiyo-e Explained*. Kent, UK: Global Oriental.
- Bell, J. (2005) *Doing Your Research Project: A Guide for First-time Researchers in Education, Health and Social Science*. Open University Press.
- Beloit College (1892) *The Codex*. Beloit, Wisconsin: Beloit College (Beloit College). Available at: <http://archive.org/details/codex00belo> (Accessed: 20 September 2015).
- Bennett, W. W. (1892) 'The air brush journal', *The air brush journal*, 2(3). Available at: http://www.airbrushmuseum.com/airbrush_lit_1892_Walkup_ABJ_index.htm (Accessed: 7 November 2014).
- Bergdoll, B. and Dickerman, L. (2009) *Bauhaus 1919-1933: Workshops for Modernity*. New York: The Museum of Modern Art.

Biographical Publishing Co. (1892) *Portrait and biographical record of Winnebago and Boone counties, Illinois: containing biographical sketches of prominent and representative citizens, together with biographies of all the governors of the state, and of the presidents of the United States*. Chicago: Biographical publishing co. Available at: <http://catalog.hathitrust.org/Record/001874608> (Accessed: 7 November 2014).

Black, C. (1984) *Conservation Ethics: An Informal Interview*. Available at: <http://cool.conservation-us.org/waac/wn/wn06/wn06-3/wn06-301.html> (Accessed: 17 November 2015).

Boer, W. den (2011) *Active Matrix Liquid Crystal Displays: Fundamentals and Applications*. Elsevier.

Boothe, R. G. (2002) *Perception of the visual environment*. New York: Springer.

Brace, I. (2008) *Questionnaire Design: How to Plan, Structure and Write Survey Material f*. Kogan Page Publishers.

Bracht, E., Glanzer, I. and Wijnberg, L. (2003) 'Barnett Newman's cathedra (1951) : the restoration of slash damages in a colourfield painting', *Alternatives to lining*, pp. 21–28.

Breek, R. and Froentjes, W. (1975) 'Application of Pyrolysis Gas Chromatography on Some of Van Meegeren's Faked Vermeers and Pieter de Hooghs', *Studies in Conservation*, 20(4), pp. 183–189. doi: 10.2307/1505738.

Brennesholtz, M. S. and Stupp, E. H. (2008) *Projection Displays*. John Wiley & Sons.

Browne, E. (1891) 'Miscellaneous Industries: Air Brush Manufacturing Company', *Industrial and picturesque Rockford*, p. 49.

Brown, J. and Bacon, A. (2002) 'Perspectives on image reintegration', *The Paper Conservator*, 26(1), pp. 5–12. doi: 10.1080/03094227.2002.9638617.

Brown, R., Kockott, D., Trubiroha, P., Ketola, W. and Shorthouse, J. (1995) 'A Review of Accelerated Durability Tests', *Versailles Project on Advanced Materials and Standards (VAMAS Report no. 18)*.

Bucklow, S. (2010) 'The state of research into retouching resins', *Mixing and Matching: Approaches to Retouching Paintings*, p. 61.

Burdick, C. L. (1892) 'Air-brush'. Available at: <http://www.google.co.uk/patents/US474157> (Accessed: 30 January 2015).

Cambridge (2014) *Exhibitions, Mark Rothko's Harvard Murals, Harvard Art Museums*. Available at: <http://www.harvardartmuseums.org/> (Accessed: 10 November 2014).

Cbe, G. T. (1994) *Museum Environment*. 2 edition. London: Routledge.

Chicago Daily Tribune (1872-1922) (1895) 'AIR BRUSH TRADE-MARK INVOLVED'. Available at: <http://search.proquest.com/docview/175163945?accountid=12860> (Accessed: 7 November 2014).

Chilvers, I. (2009) *The Oxford Dictionary of Art and Artists*. Oxford, UK: Oxford University Press.

Chilvers, I. and Graves-Smith, J. (2009) *A Dictionary of Modern and Contemporary Art*. Oxford, UK: Oxford University Press.

- Christensen, D. and Peters, L. N. (2011) *Dan Christensen: The Stain Paintings, 1976-1988*. Spanierman Gallery LLC.
- Clair, S. M. S. (1889) 'The City of Rockford', *Frank Leslie's Illustrated Newspaper*. 1789th edn, 28 December. Available at: <http://find.galegroup.com/ncnp/infomark.do?&source=gale&prodId=NCNP&userGroupName=unn&tabID=T003&docPage=article&searchType=AdvancedSearchForm&docId=GT3012623937&type=multipage&contentSet=LTO&version=1.0> (Accessed: 7 November 2014).
- Clements, A. (2012) 'Ancient Perception of Colour', *The Oxford Classical Dictionary*. 4th edn. Oxford, UK: Oxford University Press. Available at: <http://www.oxfordreference.com/10.1093/acref/9780199545568.001.0001/acref-9780199545568-e-6980> (Accessed: 24 November 2014).
- Close, C., Wye, D., Varnedoe, K. and Storr, R. (1998) *Chuck Close*. New York: Museum of Modern Art. Available at: <http://prism.talis.com/northumbria-ac/items/797613> (Accessed: 7 November 2014).
- Cottingham, D. (2013) *The Avant Garde: A Very Short Introduction*. OUP Oxford.
- COVE, S. ; C. Alan (1990) 'Restoring the English icon : portraits by William Larkin, 1610-1619', in Booth, P., Carlyle, L., Davies, M., Sitwell, C. L., Kalinsky, N., Southall, A., Todd, V., and Townsend, J. (eds). *Appearance, opinion, change : evaluating the look of paintings*, London: The United Kingdom Institute for Conservation of Historic and Artistic Works, pp. 45–49.
- Cuellar, S., Stenger, J., Gschwind, R., Mukaigawa, Y., Raskar, R., Eremin, K. and Khandekar, N. (2011) 'Non-Invasive Color Restoration of Faded Paintings Using Light from a Digital Projector', in. *ICOM-CC 16th Triennial conference*, pp. 1–9. Available at: <http://scholar.princeton.edu/scuellar/pages/projects> (Accessed: 7 November 2014).
- Curtis, L. L. (1881) 'Atomizer for Coloring Pictures'. United States Patent Office. Available at: <http://www.google.co.uk/patents?id=fgxQAAAAEBAJ> (Accessed: 23 August 2011).
- Curtis, S. T. and Hunt, C. (1980) *The airbrush book: art, history and technique*. London: Orbis.
- Cuttle, C. (2007) *Light for Art's Sake: Lighting for Artworks and Museum Displays*. London: Routledge.
- Davenport, A. (1991) *The History of Photography: An Overview*. UNM Press.
- 'Definition of Airbrush' (2011) *Merriam Webster*. Encyclopædia Britannica Company. Available at: <http://www.merriam-webster.com/dictionary/airbrush> (Accessed: 18 February 2015).
- Derrick, M. R., Stulik, D. and Landry, J. M. (1999) *Infrared Spectroscopy in Conservation Science*. Los Angeles: Getty Publications (Scientific Tools for Conservation).
- Description and Price of the Air Brush* (1884). Rockford: The Air-Brush MFG. Co. Available at: http://www.airbrushmuseum.com/airbrush_lit_1884_Walkup_Cat_index.htm (Accessed: 7 November 2014).
- De Witte, E. and Terfve, A. (1982) 'The use of a PY-GC-MS technique for the analysis of synthetic resins', *Studies in Conservation*, 27(Supplement-1), pp. 16–18.

Diamonstein-Spielvogel, B. (1979) 'Inside New York's Art World: Chuck Close'. Youtube. Available at: <http://www.youtube.com/watch?v=enF9ldgjFow> (Accessed: 7 November 2014).

Dilemmas in Contemporary Art: Richard Hamilton's Hommage à Chrysler Corp. 1957 (no date). Available at: <http://www.tate.org.uk/about/projects/dilemmas-contemporary-art-richard-hamiltons-hommage-chrysler-corp-1957> (Accessed: 2 February 2015).

Drinker, H. S. (1883) *Treatise on Explosive Compounds, Machine Rock Drills and Blasting...* J. Wiley & sons.

Dunkerton, J. (2010) 'Retouching with Gamblin Conservation Colors', in *Mixing and Matching*. London: Archetype.

Dunkerton, J., Roy, A. and Smith, A. (1987) 'The Unmasking of Tura's' Allegorical Figure': A Painting and its Concealed Image', *National Gallery Technical Bulletin*, pp. 5–35.

Echlin, P. (2011) *Handbook of Sample Preparation for Scanning Electron Microscopy and X-Ray Microanalysis*. Springer Science & Business Media.

Egerton, R. (2006) *Physical Principles of Electron Microscopy: An Introduction to TEM, SEM, and AEM*. Springer Science & Business Media.

Eldridge, D. N. (2008) *American Culture in the 1930s*. Edinburgh University Press.

Elkins, J. (2004) *What Painting Is*. London: Routledge.

Ellsworth, S. (1903) 'Liberty Walkup', *Rockford today: historical, descriptive, biographical*, p. 139.

Everts, S. (2011) 'Using A Digital Light Projector To Restore Mark Rothko Paintings | Artful Science', 26 September. Available at: <http://cenblog.org/artful-science/2011/09/26/using-a-digital-light-projector-to-restore-mark-rothko-paintings/> (Accessed: 7 November 2014).

Feller, R. L. (1994) *Accelerated aging: photochemical and thermal aspects*. Marina del Rey, CA: Getty Conservation Institute. Available at: <http://capitadiscovery.co.uk/northumbria-ac/items/690767> (Accessed: 22 February 2015).

Finch, C. (2012) *Chuck Close: Life*. New York: Prestel Verlag.

Flick, E. W. (1994) *Water-Based Paint Formulations*. New Jersey: Noyes Publications.

Fort Dodge Chronicle (1893) 'A Noted Inventor'. Available at: <http://www.abnerpeeler.com/id20.html> (Accessed: 7 November 2014).

Franklin Institute (1887) 'Air Brush, Report of the Committee on Science and the Arts', *Journal of the Franklin Institute*, 123(2), pp. 157–159.

Frazer, S. W. (1915) *Treatise on the Air Brush*. S.W. Frazer. Available at: <https://books.google.co.uk/books?id=X9Y0AQAAMAAJ> (Accessed: 29 January 2015).

Fried, M. (1998) *Art and Objecthood: Essays and Reviews*. Chicago: University of Chicago Press.

Fuchs, P., Moreau, G. and Guitton, P. (2011) *Virtual Reality: Concepts and Technologies*. Boca Raton, Florida: CRC Press.

Garner, S. (2008) *Writing on Drawing: Essays on Drawing Practice and Research*. Bristol: Intellect Books.

Gerard, J. N. (1873) 'Improvement in Atomizers or Vaporizers'. United States Patent Office. Available at: www.google.co.uk/patents?id=f_pSAAAAEBAJ (Accessed: 23 August 2011).

Gettings, F. (1971) *Polymer Painting Manual*. Studio Vista Books.

Goldman, S. M. (1974) 'Siqueiros and Three Early Murals in Los Angeles', *Art Journal*, 33(4), pp. 321–327.

Gutierrez, J. L. (1956) *From Fresco to Plastics: New Materials for Easel and Mural Paintings*. Ottawa: National Gallery.

Gutiérrez, J. L. and Roukes, N. (1965) *Painting with acrylics*. New York: Watson-Guption Publications.

Hannavy, J. (2013) *Encyclopedia of Nineteenth-Century Photography*. Routledge.

Hearth and Home (1894) 'PEOPLE, PLACES, AND THINGS.', 181st edn, 1 November, p. 883.

Heller, S. (2013) *Pop: How graphic design shapes popular culture*. Skyhorse Publishing, Inc.

'History of Politec' (no date) *politecacrylics.com*. Available at: http://www.politecacrylics.com/?page_id=54 (Accessed: 9 February 2015).

Holmes, T. J. (1876) 'Improvement in Atomizers'. United States Patent Office Patent. Available at: <http://www.google.co.uk/patents?id=iTpUAAAAEBAJ> (Accessed: 23 August 2011).

Honnet, K. (2004) *Pop Art*. Cologne: Taschen.

How to Mount a 150lbs CRT Projector on the Ceiling (2014). Available at: https://www.youtube.com/watch?v=CURsJDfdbc&feature=youtu_gdata_player (Accessed: 26 January 2015).

Hurlburt, L. P. (1976) 'The Siqueiros Experimental Workshop: New York, 1936', *Art Journal*, 35(3), pp. 237–246.

Ilsbrand M. C. Hummelen and Dionne Sillé (2005) *Modern Art - who Cares?: An Interdisciplinary Research Project and an International Symposium on the Conservation of Modern and Contemporary Art*. London: Archetype.

Inside New York's Art World: Chuck Close (1979). (Inside New York's Art World). Available at: https://www.youtube.com/watch?v=enF9ldgjFow&feature=youtu_gdata_player (Accessed: 7 November 2014).

Institute for the Conservation of Cultural Material (1985) *Conservation and contemporary art: proceedings of the Institute for the Conservation of Cultural Material Incorporated (I.C.C.M. Inc.), 1984 conference, Sydney*. Sydney: ICCM.

Ivergard, T. and Hunt, B. (2008) *Handbook of Control Room Design and Ergonomics: A Perspective for the Future, Second Edition*. Boca Raton, Florida: CRC Press.

Jablonski, E., Learner, T., Hayes, J. and Golden, M. (no date) 'The Conservation of Acrylic Emulsion Paintings: A Literature Review'. Available at: <http://oldsite.goldenpaints.com/conservation/conservation.pdf> (Accessed: 12 August 2014).

Jacobs, G. H. (1997) 'Color vision polymorphisms in New World monkeys: implications for the evolution of primate trichromacy', *New World primates: ecology, evolution and behaviour*. Walter de Gruyter, New York, pp. 45–74.

J. Michael Bowling (1986) *Questionnaire design*. Raleigh, N.C: State Center for Health Statistics.

Jones, B. E. (1911) *Cassell's Cyclopaedia of Photography*. London: Cassell and Company, LTD. Available at: <http://archive.org/details/cu31924030707867> (Accessed: 7 November 2014).

Karmel, P. (1999) *Jackson Pollock: Interviews, Articles, and Reviews*. New York: The Museum of Modern Art.

Kassel, M. B. (2001) 'Airbrush Painting', in Browne, R. B. and Browne, P. (eds) *The Guide to United States Popular Culture*. Madison: The University of Wisconsin (Book, Whole), p. 20. Available at: <http://books.google.co.uk/books?id=U3rJxPYT32MC> (Accessed: 7 November 2014).

Kate Chase (2012) *Talking Retouching, Communication Arts*. Available at: <http://www.commarts.com/columns/talking-retouching> (Accessed: 30 January 2015).

Kate Lowry (2010) 'Retouching with Paraloid b-72', *Mixing and Matching: Approaches to Retouching Paintings*, pp. 87–91.

Kelly, F. (1972) *Art restoration; a guide to the care and preservation of works of art*. New York: McGraw-Hill.

Kemp, M. (2000) *The Oxford History of Western Art*. Oxford University Press.

Kirsh, A. and Levenson, R. S. (2000) *Seeing Through Paintings: Physical Examination in Art Historical Studies*. New Haven: Yale University Press.

Kleiner, F. (2013) *Gardner's Art through the Ages: A Concise History of Western Art*. Cengage Learning.

Koneczny, P. (2010) 'Properties of pigments and retouching media and their use', in *Mixing and Matching: Approaches to Retouching Paintings*. London: Archetype, p. 66.

Kricheldorf, H. R., Nuyken, O. and Swift, G. (2004) *Handbook of Polymer Synthesis: Second Edition*. Boca Raton, Florida: CRC Press.

Kumar, A. (2002) *Research Methodology in Social Science*. Delhi: Sarup & Sons.

Kuspit, D. B. (2002) *Don Eddy: The Art of Paradox*. Manchester, US: Hudson Hills Press.

Lafontaine, R. H. (1986) 'Seeing through a yellow varnish: a compensating illumination system', *Studies in Conservation*, 31(3), pp. 97–102.

- Law, A. J., Aliaga, D. G., Yeung, Y. H., McCoy, R., McKune, A. and Zimmerman, L. (2009) 'Projecting Restorations in Real-Time for Real-World Objects', in *Museums and the Web 2009: Proceedings. Archives & Museum Informatics: Museums and the Web 2009*, Toronto: Archives & Museum Informatics. Available at: <http://www.archimuse.com/mw2009/papers/law/law.html> (Accessed: 21 October 2009).
- Learner, T. (1998) 'The use of a diamond cell for the FTIR characterisation of paints and varnishes available to twentieth century artists', in. *Postprints: infrared and Raman user's group conference. Victoria and Albert Museum, London*, pp. 7–20.
- Learner, T. (2005) *Analysis of modern paints*. Los Angeles: Getty Conservation Institute. Available at: <http://prism.talis.com/northumbria-ac/items/1220288>.
- Learner, T. (2005) 'Modern paints', *Scientific Examination of Art: Modern Techniques in Conservation and Analysis*, pp. 137–151.
- Learner, T. (2007) *Modern paints uncovered: proceedings from the modern paints uncovered symposium*. Los Angeles: Getty Conservation Institute.
- Learner, T. (2007) 'Modern paints: uncovering the choices', in *Modern paints uncovered: proceedings from the modern paints uncovered symposium*. Los Angeles: Getty Conservation Institute.
- Ledtronics (2010) 'LEDtronics LED Bulbs Help Art Museum toward Environmental Sustainability', *BeLight*. Available at: <https://books.google.co.uk/books?id=J5CSWdSUBKEC> (Accessed: 27 January 2015).
- Leonard Bocour (1978) 'Oral history interview with Leonard Bocour'. Available at: <http://www.aaa.si.edu/collections/interviews/oral-history-interview-leonard-bocour-12884> (Accessed: 25 December 2014).
- Leonard, M., Whitten, J., Gamblin, R. and de la Rie, E. R. (2000) 'Development of a new material for retouching', *Studies in Conservation*, 45(Supplement-1), pp. 111–113.
- Lilien, O. M. (1985) *Jacob Christoph Le Blon, 1667-1741: Inventor of Three- and Four Colour Printing*. Hiersemann.
- Limited, I. T. L. E. S. and Esl, I. (2004) *Introduction to Computer Science*. Pearson Education India.
- Linhares, J. M. M., Pinto, P. D. and Nascimento, S. M. C. (2008) 'The number of discernible colors in natural scenes', *J. Opt. Soc. Am. A*, 25(12), pp. 2918–2924.
- Lockwood, H. D. (1872) 'Improvement in Atomizers'. United States Patent Office. Available at: http://www.google.co.uk/patents?id=kNw_AAAAEBAJ (Accessed: 23 August 2011).
- Lomax, S. Q., Schilling, M. R. and Learner, T. (2007) 'The identification of synthetic organic pigments by FTIR and DTMS', *Modern paints uncovered. Getty Conservation Institute, Los Angeles*, pp. 105–117.
- Louis, M. and Upright, D. (1985) *Morris Louis, the complete paintings: a catalogue raisonné*. New York: Abrams.
- Ludington, T. (2000) *A Modern Mosaic: Art and Modernism in the United States*. UNC Press Books.

- Luxford, N. and Thickett, D. (2011) 'Designing accelerated ageing experiments to study silk deterioration in historic houses', *Journal of the Institute of Conservation*, 34(1), pp. 115–127.
- Magnolia Editions* (2009) 'A Conversation With Chuck Close', 18th edn, p. 4.
- Martin, J. (1983) *The complete guide to airbrushing: techniques and materials*. London: Thames and Hudson.
- Mayer, R. and Sheehan, S. (1991) *The Artist's Handbook of Materials and Techniques*. Faber & Faber. Available at: <https://books.google.co.uk/books?id=fe6mQgAACAAJ> (Accessed: 4 February 2014).
- McGraw, K. (2004) 'Multiple UV reflectance peaks in the iridescent neck feathers of pigeons', *Naturwissenschaften*, 91(3), pp. 125–129.
- McShane, C. (1899) *The Locomotive Up to Date: the Classic Reference for Steam Locomotive Engineers and Firemen*. Available at: <https://books.google.com.eg/books?id=Ahd4izJ5RXUC> (Accessed: 12 September 2015).
- Meisel, L. K. and Seeman, H. Z. (1989) *Photo-Realism*. New York: Abradale Press.
- Merlin, B. (2011) *Airbrush History: The First! F. E. Stanley's Atomizer/Airbrush*. Available at: http://www.airbrushmuseum.com/airbrush_history_stanley_1.1.htm (Accessed: 7 November 2014).
- Mills, J. and White, R. (2012) *Organic Chemistry of Museum Objects*. London: Routledge.
- Mogford, H. (1845) *Hand-book for the preservation of pictures, containing practical instruction for cleaning, lining, repairing, restoring, and preserving oil paintings*. Lond.
- Molinard, S. (2005) *Double take: photorealism from the 1960s and '70s : the Rose Art Museum, Brandeis University, Waltham, Massachusetts*. Rose Art Museum, Brandeis University.
- Moorhead, J. (1999) *Pop Impressions Europe/USA: Prints and Multiples from the Museum of Modern Art*. New York: The Museum of Modern Art.
- Muir, K. (2009) 'Approaches to the reintegration of paint loss: theory and practice in the conservation of easel paintings', *Studies in Conservation*, 54(Supplement-1), pp. 19–28.
- Muñoz Viñas, S. (2005) *Contemporary theory of conservation*. Oxford: Elsevier Butterworth-Heinemann.
- Nadolny, J. (2012) 'History of visual compensation for paintings', in Stoner, J. H. and Rushfield, R. (eds) *Conservation of Easel Paintings*. 1st edn. London: Routledge (Routledge Series in Conservation and Museology), pp. 573–85.
- the National Gallery of Canada (1980) *International Symposium on the Conservation of Contemporary Art: 7-12 July 1980 ; Abstracts*. National Museums of Canada.
- Naud, C. (1990) 'A Filter that Compensates for a Yellowed Varnish', *Studies in Conservation*, 35(Supplement-2), pp. 13–13.

- Naumann, F. M. (2003) *Conversion to Modernism: the early work of Man Ray*. Piscataway, N.J London: Rutgers University Press. Available at: <http://prism.talis.com/northumbria-ac/items/1130078>.
- Neher, H. T. (1936) 'Acrylic Resins', *Industrial & Engineering Chemistry*, 28(3), pp. 267–271.
- New York Times (1884) 'Attractions of the Great Fair', *New York Times (1857-1922)*. Available at: <http://search.proquest.com/docview/94198035?accountid=12860> (Accessed: 7 November 2014).
- New-York tribune (1898) 'Classified Advertisements', *New-York tribune*, 21 May. Available at: chroniclingamerica.loc.gov/lccn/sn83030214/1898-05-21/ed-1/seq-14/ (Accessed: 7 November 2014).
- Nicolaus, K. (1999) *The restoration of paintings*. Edited by C. Westphal. Cologne: Könemann. Available at: <http://capitadiscovery.co.uk/northumbria-ac/items/835806> (Accessed: 1 January 2002).
- Oddy, W. A. (1992) *The Art of the conservator*. Washington, D. C.: Smithsonian Institution Press.
- Olitski, J. (1968) *Instant Loveland*. Available at: <http://www.tate.org.uk/art/artists/jules-olitski-2198> (Accessed: 9 February 2015).
- Oppenheim, A. N. (2000) *Questionnaire Design, Interviewing and Attitude Measurement*. London: Bloomsbury Publishing.
- Oxford (2012) *Benezit Dictionary of British Graphic Artists and Illustrators*. Oxford, UK: Oxford University Press.
- Peeler, A. (1882) 'Paint Distributer'. United States Patent Office. Available at: www.google.co.uk/patents?id=m9ddAAAAEBAJ (Accessed: 23 August 2011).
- Penaluna, A. (2001) *History of the Airbrush: 1882 - Airbrush Pioneer, Liberty Walkup*. Available at: <http://www.andypenaluna.com/history/1882pages/1882Pion.html> (Accessed: 7 November 2014).
- Penaluna, A. (2003) *A critical investigation into the origins and development of the airbrush - 1878-1906*. Unpublished Doctoral Thesis. Swansea Institute, University of Wales.
- Perrin, F. ., Irigoyen, M., Aragon, E. and Vernet, J. . (2001) 'Evaluation of accelerated weathering tests for three paint systems: a comparative study of their aging behaviour', *Polymer Degradation and Stability*, 72(1), pp. 115–124.
- Peter H. Putman (2010) *3LCD: Projection Technology for the 21st Century*. Available at: <http://www.3lcd.com/explore/papers.aspx> (Accessed: 25 January 2015).
- Pittsburg Dispatch (1891) 'Classified Advertisements', *Pittsburg Dispatch*, 9 August. Available at: chroniclingamerica.loc.gov/lccn/sn84024546/1891-08-09/ed-1/seq-11/ (Accessed: 7 November 2014).
- Porck, J. J. (2000) 'Rate of Paper Degradation. The Predictive Value of Artificial Aging Tests', in: Amsterdam: European Commission on Preservation and Access. Available at: <http://www.ica.org/download.php?id=604> (Accessed: 22 February 2015).

- Poulsson, T. G. (2008) *Retouching of art on paper*. London: Archetype. Available at: <http://capitadiscovery.co.uk/northumbria-ac/items/1392014> (Accessed: 7 November 2014).
- Proulx, T. (2012) *Application of Imaging Techniques to Mechanics of Materials and Structures, Volume 4: Proceedings of the 2010 Annual Conference on Experimental and Applied Mechanics*. Springer Science & Business Media.
- Rand, A. C. (1894) *The uses of compressed air : with illustrations*. New York: The Republic Press. Available at: <http://catalog.hathitrust.org/Record/006543372> (Accessed: 7 November 2014).
- Randee Silv (2013) 'Interrupting Siqueiros: San Miguel & LA', *ARTEIDOLIA*, December. Available at: <http://www.arteidolia.com/interrupting-siqueiros-randee-silv/> (Accessed: 9 February 2015).
- Review: Epson Powerlite 1761W Projector* (2013). Available at: <https://youtu.be/gR9t0t-VsuM> (Accessed: 26 January 2015).
- Rewald, S. (1988) *Paul Klee: The Berggruen Klee Collection in the Metropolitan Museum of Art*. New York: Metropolitan Museum of Art. Available at: <http://books.google.co.uk/books?id=S8oMI0FdXckC>.
- Rintoul, A. N. (1863) *A Guide to Painting Photographic Portraits, Draperies, Backgrounds, etc.* 4th edn. London: Adams and Gee. Available at: books.google.com.eg/books?id=KzZkAAAACAAJ.
- Robert Johnson (1936) *The Art Of Retouching Photographic Negatives*. American Photographic Publishing Co. Available at: <http://archive.org/details/artofretouchingp002528mbp> (Accessed: 29 January 2015).
- Rogério-Candelera, M. A., Lazzari, M. and Cano, E. (2013) *Science and Technology for the Conservation of Cultural Heritage*. Boca Raton, Florida: CRC Press.
- Roy A. Perry (2000) 'Retouching damaged Modern Art', in *Retouching & Filling*. London: The Association of British Picture Restorers, pp. 19–22.
- Ruhemann, H. and Plesters, J. (1968) *The cleaning of paintings: problems and potentialities*. London: Faber. Available at: <http://capitadiscovery.co.uk/northumbria-ac/items/251233> (Accessed: 1 January 2002).
- Russell, J. (2010) *A study of the materials and techniques of Francis Bacon (1909 - 1992)*. doctoral. Northumbria University. Available at: <http://nrl.northumbria.ac.uk/3156/> (Accessed: 9 February 2015).
- Russell, J. E., Singer, B. W., Perry, J. J. and Bacon, A. (2012) 'Investigation of the materials found in the studio of Francis Bacon (1909–1992)', *Studies in Conservation*, 57(4), pp. 195–206.
- Russell, J., Singer, B. W., Perry, J. J. and Bacon, A. (2011) 'The identification of synthetic organic pigments in modern paints and modern paintings using pyrolysis-gas chromatography-mass spectrometry', *Analytical and Bioanalytical Chemistry*, 400(5), pp. 1473–1491.
- Saunders, D. (1995) 'Photographic flash: threat or nuisance?', *The National Gallery Technical Bulletin*, 16(1), pp. 66–72.

- Saunders, D. (2000) 'Retouching: colour vision and optical considerations', in *Retouching & Filling*. *Retouching & Filling*, London: Association of British Picture Restorers, pp. 3–9.
- Schaeffer, T. T. (2001) *Effects of light on materials in collections : data on photoflash and related sources*. Los Angeles: Getty Conservation Institute.
- Schwarz, A. (1977) *Man Ray: the rigour of imagination*. London: Thames and Hudson. Available at: <http://prism.talis.com/northumbria-ac/items/277957> (Accessed: 7 November 2014).
- Selz, P. H. and Landauer, S. (2006) *Art of Engagement: Visual Politics in California and Beyond*. University of California Press.
- Sharpe, E. (2010) *Missing piece of 16th-century mural recreated virtually*, *The Art Newspaper*. Available at: <http://www.theartnewspaper.com/articles/Missing+piece+of+16th-century+mural+recreated+virtually/21757> (Accessed: 10 November 2014).
- Shea, A. (2014a) *After Decades In Storage, Damaged Rothko Murals Get High-Tech Restoration*. Available at: <http://www.npr.org/2014/07/11/330509103/after-decades-in-storage-damaged-rothko-murals-get-high-tech-restoration> (Accessed: 7 November 2014).
- Shea, A. (2014b) *Harvard's Famously Damaged Rothko Paintings 'Restored' With Light | ARTery*. Available at: <http://artery.wbur.org/2014/05/20/harvard-rothkos> (Accessed: 7 November 2014).
- Shurtleff, A. M. (1866) 'Improvement in atomizing tubes'. United States Patent Office. Available at: www.google.co.uk/patents?id=d2wAAAAEBAJ (Accessed: 23 August 2011).
- Shurtleff, A. M. (1869) 'Improved Atomizing-Apparatus'. United States Patent Office. Available at: www.google.co.uk/patents?id=NixCAAAEBAJ (Accessed: 23 August 2011).
- Shurtleff, A. M. (1871) 'Improvement in Apparatus for Atomizing Liquids'. United States Patent Office. Available at: www.google.co.uk/patents?id=i8ljAAAAEBAJ (Accessed: 23 August 2011).
- Sikri, V. K. (2010) 'Color: Implications in dentistry', *Journal of Conservative Dentistry : JCD*, 13(4), pp. 249–255.
- Simon Hennessey (2015) 'Meet Simon Hennessey, Our First Diamond Artist'. Available at: <http://www.liquitex.com/PB1Col.aspx?pageid=91&id=22782> (Accessed: 1 February 2015).
- Smithen, P. (2007) 'A history of the treatment of acrylic painting', in *Modern Paints Uncovered, Proceedings from the Modern Paints Uncovered Symposium, May 16–19, 2006, Tate Modern, London*, pp. 165–174.
- Smith, G. D. (2007) 'Aging characteristics of a contemporary acrylic emulsion used in artists' paints', *Modern Paints Uncovered*, pp. 236–246.
- Soltan, M. A. (2010) *An Investigation into Materials and Techniques for Historical Linings*. MA Dissertation. Northumbria University. Available at: www.academia.edu/3428335/An_Investigation_into_Materials_and_Techniques_for_Historical_Linings.
- Sonoda, N. (1999) 'Characterization of Organic Azo-Pigments by Pyrolysis-Gas Chromatography', *Studies in Conservation*, 44(3), pp. 195–208. doi: 10.2307/1506705.

- Sonoda, N. and Rioux-a2, J.-P. (1990) 'Identification des matériaux synthétiques dans les peintures modernes. I. Vernis et liants polymères', *Studies in Conservation*, 35(4), pp. 189–204. doi: 10.1179/sic.1990.35.4.189.
- Sonoda, N., Rioux-a2, J.-P. and Duval, A. R. (1993) 'Identification des matériaux synthétiques dans les peintures modernes. II. pigments organiques et matière picturale', *Studies in Conservation*, 38(2), pp. 99–127. doi: 10.1179/sic.1993.38.2.99.
- Spencer, H. (1998) 'Wilson Henry Irvine and the Poetry of Light', *American Art Review*. Available at: <http://www.tfaoi.org/aa/9aa/9aa112.htm> (Accessed: 7 November 2014).
- Spencer, H. R. (1875) 'Improvement in Atomizers'. United States Patent Office. Available at: www.google.co.uk/patents?id=R81NAAAEB AJ (Accessed: 23 August 2011).
- Springfield Globe-Republic (1886) 'Local Brevities', *Springfield Globe-Republic*, 7 August. Available at: <http://chroniclingamerica.loc.gov/lccn/sn87076916/1886-08-07/ed-1/seq-4/> (Accessed: 7 November 2014).
- Standeven, H. (2007) "'Cover the Earth": A History of the Manufacture of Household Gloss Paints in Britain and the United States', in *Modern Paints Uncovered: Proceedings from the Modern Paints Uncovered Symposium*, Getty Publications, p. 75.
- Standeven, H. A. L. (2011) *House Paints, 1900-1960: History and Use*. Getty Publications. Available at: <http://books.google.co.uk/books?id=1WviUh1u5UYC> (Accessed: 7 November 2014).
- Stanley, F. E. (1876) 'Improvement in Atomizers'. United States Patent Office. Available at: www.google.co.uk/patents?id=V_1cAAAAEB AJ (Accessed: 23 August 2011).
- Stein, P. (1994) *Siqueiros: His Life and Works*. International Publishers. Available at: <http://books.google.co.uk/books?id=cVNBwF5sLr4C> (Accessed: 7 November 2014).
- Stephanie Salomon (2007) *Color as Field: American Painting, 1950-1975*. New York: Yale University Press.
- Stine, G. F. (1920) *The air brush in photography*. Cleveland: Ohio., The Abel publishing company (144 p.). Available at: <http://catalog.hathitrust.org/Record/011225081> (Accessed: 29 January 2015).
- Storr, R. (1998) *Chuck Close*. New York: The Museum of Modern Art.
- Svensden, L. A. (1980) 'Kandinsky, Hilla Rebay and the Guggenheim Museum', in *Kandinsky watercolors : a selection from the Solomon R. Guggenheim Museum and the Hilla von Rebay Foundation*. New York: Solomon R. Guggenheim Foundation. Available at: <http://archive.org/details/waterco00solo> (Accessed: 2 October 2015).
- The Commercial Appeal (1895) 'Explosion and Fire at Rockford', *The Commercial Appeal*, 11 November. Available at: <http://find.galegroup.com/ncnp/infomark.do?&source=gale&prodId=NCNP&userGroupName=unn&tabID=T003&docPage=article&searchType=AdvancedSearchForm&docId=GT3016100268&type=multipage&contentSet=LTO&version=1.0>.
- The Daily Inter Ocean (1895) 'Serious Fire in Rockford', *The Daily Inter Ocean*, 10 November. Available at:

<http://find.galegroup.com/ncnp/infomark.do?&source=gale&prodId=NCNP&userGroupName=unn&tabID=T003&docPage=article&searchType=AdvancedSearchForm&docId=GT3001576752&type=multipage&contentSet=LTO&version=1.0>.

The Evening Times (1898) 'Classified Advertisements', *The Evening Times*, 7 December. Available at: chroniclingamerica.loc.gov/lccn/sn84024441/1898-12-07/ed-1/seq-7/.

The Evening World (1893) 'Classified Advertisements', *The Evening World*, 6 July. Available at: chroniclingamerica.loc.gov/lccn/sn83030193/1893-07-06/ed-3/seq-7/ (Accessed: 7 November 2014).

The Hole NYC (2014) 'Go with the Flow'. Available at: <http://theholenyc.com/2014/07/03/go-with-the-flow/> (Accessed: 9 February 2015).

The Milwaukee Sentinel (1885) 'Classified Advertisements', *The Milwaukee Sentinel*, 9 September. Available at: http://infotrac.galegroup.com/itw/infomark/739/368/151466402w16/purl=rc1_NCNP_0_GT3009718227&dyn=8lxrn_2_0_GT3009718227&hst_1?sw_aep=unn (Accessed: 7 November 2014).

The Morning Call (1894) 'Wahlstad's Drawing School Advertisement', *The Morning Call*, 14 October. Available at: chroniclingamerica.loc.gov/lccn/sn94052989/1894-10-14/ed-1/seq-4 (Accessed: 7 November 2014).

The Philadelphia Photographer (1883) 'The Air Brush MFG. Co. advertisement', *The Philadelphia Photographer*, 20(239), p. 402.

The Photographic Times (1888) 'Exhibition of Photographs at the Minneapolis Convention', *The Photographic Times*, 27 July, pp. 349–351.

The San Francisco Call (1896) 'Classified Advertisements', *The San Francisco Call*, 19 April. Available at: chroniclingamerica.loc.gov/lccn/sn85066387/1896-04-19/ed-1/seq-12/ (Accessed: 7 November 2014).

The Sunday School Times (1890) 'Advertisement of the Illinois Art School', *The Sunday School Times*, 1 May.

Thompson, E. (1995) *Colour Vision a Study in Cognitive Science and Philosophy of Science*. Available at: <http://public.eblib.com/choice/publicfullrecord.aspx?p=179310> (Accessed: 25 November 2014).

Tinterow, G. and Stein, S. A. (2010) *Picasso in the Metropolitan Museum of Art*. Metropolitan Museum of Art.

Tobias, J. C. (2012) *A manual of airbrush technique*. Boston, Mass.: American photographic publishing co. Available at: http://openlibrary.org/works/OL7590901W/A_manual_of_airbrush_technique (Accessed: 7 November 2014).

Tom Learner and Bronwyn Ormsby (2012) 'Cleaning concerns for acrylic emulsion paints', in *Conservation of Easel Paintings*. London: Routledge.

Vaus, D. de (2013) *Surveys in Social Research*. London: Routledge.

- Vergnaud, A. D. (1831) *Manuel du peintre en batimens, du fabricant de couleurs, du vitrier, du doreur, du vernisseur, et de l'argenteur*. Roret. Available at: <http://books.google.co.uk/books?id=WvYNAAYAAJ>.
- Vogel, C. (1997) 'Dutch Vandal Slashes Museums' Confidence', *The New York Times*, 27 November. Available at: <http://www.nytimes.com/1997/11/27/arts/dutch-vandal-slashes-museums-confidence.html> (Accessed: 2 February 2015).
- Wakerman, E. (1979) *Air powered: the art of the airbrush*. New York: Random House.
- Walkup, L. (1883) 'Paint-Distributor'. United States Patent Office. Available at: www.google.co.uk/patents?id=yEhRAAAAEBAJ (Accessed: 23 August 2011).
- Walkup, L. (1884) 'Paint-Distributor'. United States Patent Office. Available at: www.google.co.uk/patents?id=RV9oAAAAEBAJ (Accessed: 23 August 2011).
- Walkup, L. (1885) 'Paint-Distributor'. United States Patent Office. Available at: www.google.co.uk/patents?id=lthLAAAAEBAJ (Accessed: 23 August 2011).
- Walkup, L. (1905) 'Air-pump.' Available at: <http://www.google.co.uk/patents/US799695> (Accessed: 30 January 2015).
- Walkup, L. (1906) 'Air-brush.' Available at: <http://www.google.co.uk/patents/US817819> (Accessed: 30 January 2015).
- Walkup, L. (1916) 'Air-brush.' Available at: <http://www.google.co.uk/patents/US1191751> (Accessed: 30 January 2015).
- Wallace, W. V. (1876) 'Improvement in Atomizers'. United States Patent Office. Available at: www.google.co.uk/patents?id=6OpPAAAAEBAJ (Accessed: 23 August 2011).
- Ward, G. W. R. (2008) *The Grove Encyclopedia of Materials and Techniques in Art*. Oxford, UK: Oxford University Press.
- Wharton, G. (2005) 'The challenges of conserving contemporary art', *Collecting the New: Museums and Contemporary Art*, pp. 163–78.
- Whitmore, P. M. and Colaluca, V. G. (1995) 'The Natural and Accelerated Aging of an Acrylic Artists' Medium', *Studies in Conservation*, 40(1), pp. 51–64.
- Wichita Eagle (1889) 'Classified Advertisement', *Wichita Eagle*, 5 March. Available at: chroniclingamerica.loc.gov/lccn/sn85032490/1889-03-05/ed-1/seq-6/ (Accessed: 7 November 2014).
- Wilson, E. L. (1883) 'Editor's Table: The Air-Brush', *The Philadelphia Photographer*, 20(237), p. 318.
- Wilson, E. L. (1884a) 'Editor's Table: The Air-Brush', *The Philadelphia Photographer*, 21(241), pp. 30–31.
- Wilson, E. L. (1884b) 'The Air-Brush', *The Philadelphia Photographer*, 21(246), p. 173.
- Wilson, E. L. (1886) 'Editor's Table', *The Philadelphia Photographer*, 23(269), p. 159.

- Wilson, E. L. (1887a) 'A Commendable Enterprize', *The Philadelphia Photographer*, 24(290), p. 32.
- Wilson, E. L. (1887b) 'The World's Photography Focussed', *The Philadelphia Photographer*, 24(297), pp. 276–277.
- Wilson, E. L. (1888a) 'Convention Pointers', *The Philadelphia Photographer*, 25(325), p. 411.
- Wilson, E. L. (1888b) 'Proceedings of the Photographers' Association of America', *The Philadelphia Photographer*, 25(327), p. 467.
- Wilson, G. (1849) *On the Early History of the Air-Pump in England*. Edinburgh: the Edinburgh New Philosophical Journal.
- Winegrad, D. (2001) *Travels in the Labyrinth: Mexican Art in the Pollak Collection*. University of Pennsylvania Press.
- Wittrock, W. (1985) *Toulouse-Lautrec: catalogue complet des estampes*. www.acr-edition.com.
- Yeh, P. and Gu, C. (2010) *Optics of Liquid Crystal Displays*. John Wiley & Sons.
- Young, C. (2005) 'Accelerated ageing of fabric supports: is it possible?', in. *AHRB Textile Conservation Centre Conference Post Prints*, pp. 111–117.
- (1887) 'St. Paul daily globe. (Saint Paul, Minn.) 1884-1896, December 29, 1887, Image 8', 29 December, p. 7.
- (1893) 'The herald. (Los Angeles [Calif.]) 1893-1900, October 20, 1893, Image 8', 20 October, p. 8.
- (1899) 'Kansas City journal. (Kansas City, Mo.) 1897-1928, March 12, 1899, Image 18', 12 March, p. 18.

Appendices

A.1 Appendix A: Questionnaires

A.1.1 Questionnaire 1: A Survey on the Conservation of Airbrush Easel Paintings

This questionnaire was built on and distributed via sogosurvey.com. It is intended to be completed online via invitation only.

* Required Information

page 1

A Survey on the Conservation of Airbrush Easel Paintings

Hello,

Thank you in advance for taking the time to fill in this survey regarding the condition and conservation treatment of easel paintings executed with airbrushing techniques. This survey is aimed at art conservators and restorers who are particularly specialised in easel paintings. The questionnaire will take approximately 10 minutes to be completed. Your participation in this study is voluntary. There are no foreseeable risks associated with this project. However, please be assured that your personal information will be strictly confidential.

Please note the following:

- Only use the Back or Next buttons below each page. Please do NOT use the navigation buttons of your browser otherwise all data you entered may be lost.
- This survey restricts the participant to only one response. You can NOT participate in this survey more than once. However, you may save and continue later if you wish.
- Your survey timeout is set to 60 minutes of inactivity. If you leave this survey inactive for this duration, all your previous answers may be lost.

If you have questions at any time about the survey or the procedures, you may contact me by email at:

mohamed.abdeldayem@northumbria.ac.uk

Or by writing to the following address:

Mohamed Abdeldayem Soltan

Glenamara Centre

School of Arts and Social Sciences

**Northumbria University
Newcastle upon Tyne, UK
NE1 8ST**

Please start with the survey now by clicking on the Next button below.

page 2

*** 1. You are:** (Select one option)

- Male
- Female
- Prefer not to say

*** 2. Your age group is:** (Select one option)

- 19 or under 20-24 25-29 30-34 35-39
- 40-44 45-49 50-54 55-59 60 or over

*** 3. What is the highest level of education that you have completed?** (Select one option)

- Some School
- Higher Secondary
- Some College
- Some additional training

- Bachelor's degree
- Master's degree
- PhD
- Other (please specify) _____

*** 4. What is your nationality(ies)? (Select all that apply)**

- Afghanistan
- Albania
- Algeria
- Argentina
- Armenia
- Australia
- Austria
- Azerbaijan
- Bahrain
- Bangladesh
- Belarus
- Belgium
- Brazil

- Brunei
- Cambodia
- Canada
- China
- Colombia
- Costa Rica
- Croatia
- Cuba
- Cyprus
- Czech Republic
- Denmark
- Egypt
- Ethiopia
- Finland
- France
- Georgia
- Germany
- Greece
- Hong Kong
- India

- Indonesia
- Iran
- Iraq
- Ireland
- Israel
- Italy
- Japan
- Jordan
- Kazakhstan
- Kenya
- Korea, South
- Kuwait
- Lebanon
- Libya
- Malaysia

- Maldives
- Mauritius
- Mexico
- Morocco
- Myanmar
- Nepal
- Netherlands
- New Zealand
- Nigeria
- Norway
- Oman
- Pakistan
- Philippines
- Poland
- Portugal

- Qatar
- Romania
- Russia
- Saudi Arabia
- Singapore
- Slovakia
- Slovenia
- Somalia
- South Africa
- Spain
- Sri Lanka
- Sudan
- Sweden
- Switzerland
- Syria

- Taiwan
- Tajikistan
- Thailand
- Tunisia
- Turkey
- Ukraine
- United Arab Emirates
- United Kingdom
- United States of America
- Uzbekistan
- Yemen
- Zambia
- Zimbabwe
- Other (please specify) _____

*** 5. Where are you currently live? (Select one option)**

Afghanistan

Albania

Algeria

Argentina

Armenia

Australia

Austria

Azerbaijan

Bahrain

Bangladesh

Belarus

Belgium

Brazil

Brunei

Cambodia

Canada

- China
- Colombia
- Costa Rica
- Croatia
- Cuba
- Cyprus
- Czech Republic
- Denmark
- Egypt
- Ethiopia
- Finland
- France
- Georgia
- Germany
- Greece
- Hong Kong

- India
- Indonesia
- Iran
- Iraq
- Ireland
- Israel
- Italy
- Japan
- Jordan
- Kazakhstan
- Kenya
- Korea, South
- Kuwait
- Lebanon
- Libya
- Malaysia

- Maldives
- Mauritius
- Mexico
- Morocco
- Myanmar
- Nepal
- Netherlands
- New Zealand
- Nigeria
- Norway
- Oman
- Pakistan
- Philippines
- Poland
- Portugal
- Qatar

- Romania
- Russia
- Saudi Arabia
- Singapore
- Slovakia
- Slovenia
- Somalia
- South Africa
- Spain
- Sri Lanka
- Sudan
- Sweden
- Switzerland
- Syria
- Taiwan
- Tajikistan

<p><input type="radio"/> Thailand</p> <p><input type="radio"/> Tunisia</p> <p><input type="radio"/> Turkey</p> <p><input type="radio"/> Ukraine</p> <p><input type="radio"/> United Arab Emirates</p> <p><input type="radio"/> United Kingdom</p> <p><input type="radio"/> United States of America</p> <p><input type="radio"/> Uzbekistan</p> <p><input type="radio"/> Yemen</p> <p><input type="radio"/> Zambia</p> <p><input type="radio"/> Zimbabwe</p> <p><input type="radio"/> Other (please specify) _____</p>
--

page 3

*** 6. You work as:** (Select one option)

A private conservator

A museum/gallery conservator

Other (please specify) _____

*** 7. You have experience in:** (Select one option)

Traditional paintings

Contemporary paintings

Both of the above

Non of the above

*** 8. Please indicate your level of experience in the field of fine art conservation:** (Select one option)

1 year or under

2 - 3 years

4 - 5 years

6 - 7 years

8 - 9 years

10 years or above

*** 9. Your annual income is:** (Select one option)

- Less than \$20,000
- \$20,000 - \$40,999
- \$50,000 - \$70,999
- \$80,000 - \$100,999
- \$101,000 and above
- I prefer not to say

page 4

*** 10. Which type(s) of supports have you encountered while carrying out technical examination or conservation treatment on easel paintings?** (Select all that apply)

- Canvas (natural fabric, e.g. cotton)
- Canvas (synthetic fabric, e.g. polyester)
- Leather (e.g. parchment)
- Metal sheets (e.g. aluminium)
- Paper (e.g. cardboard)

Wooden panels (e.g. plywood, masonite, etc.)

Other (please specify) _____

page 5

*** 11. In your opinion, the airbrush is acceptable as an art tool for FINE ART painting? (Select one option)**

- Strongly agree
- Agree
- Not sure
- Disagree
- Strongly disagree

page 6

*** 12. In general, art historians and critics have not considered airbrush painting to be fine art? (Select one option)**

- Strongly agree
- Agree

- Not sure
- Disagree
- Strongly disagree

page 7

*** 13. The condition of a painting can also be affected by the techniques of paint application used by artists, and not only the materials employed. (Select one option)**

- Strongly agree
- Agree
- Not sure
- Disagree
- Strongly disagree

page 8

*** 14. Art conservators already have knowledge about problems that might be directly related to the airbrushing application in airbrush paintings (Select one option)**

- Strongly agree

- Agree
- Not sure
- Disagree
- Strongly disagree

page 9

*** 15. Art conservators currently lack knowledge regarding problems that might be directly related to the airbrushing application in airbrush paintings. (Select one option)**

- Strongly agree
- Agree
- Not sure
- Disagree
- Strongly disagree

page 10

*** 16. If you have an AIRBRUSH painting that needs image reintegration (e.g. filling, inpainting, etc.), then you have a clear idea of the conservation treatment you may safely use. (Select one option)**

- Strongly agree
- Agree
- Not sure
- Disagree
- Strongly disagree

page 11

*** 17. Have you ever, throughout your career, encountered AIRBRUSH easel paintings that had to undergo any type of conservation treatment? (Select one option)**

- Yes Go to Page No. 13
- No Go to Page No. 22

page 12

*** 18. On which collections did you work before? (Select one option)**

- Public
- Private

- Both
- Other (please specify) _____

page 13

*** 19. In general, there can be conservation problems in AIRBRUSH paintings different from those in the paintings executed with other paint application types. (Select one option)**

- Strongly agree
- Agree
- Not sure
- Disagree
- Strongly disagree

page 14

20. Please provide further details about problem(s) you have found specific to airbrush paintings. [Answer this question only if answer to Q#19 is NOT (Not sure AND Disagree AND Strongly disagree)]

page 15

*** 21. Which procedure you found that AIRBRUSH paintings often require? (Select all that apply)**

- Technical examination
- Preventive conservation
- Structural work (e.g. tear mending, lining)
- Cleaning (e.g. dirt removal, varnish removal)
- Image reintegration (e.g. filling, retouching)
- Nothing significant than other types of paintings
- Other (please specify) _____

page 16

*** 22. Comparing to other types of paintings, the thickness of the GROUND layer in AIRBRUSH paintings is generally: (Select one option)**

- Greater
- Lesser
- Not really different

- I am not sure
- Other (please specify) _____

page 17

*** 23. Comparing to other types of paintings, the thickness of the PAINT film in AIRBRUSH paintings is generally:** (Select one option)

- Greater
- Lesser
- Not really different
- I am not sure
- Other (please specify) _____

page 18

*** 24. How often do you encounter deterioration problems in the paint film in AIRBRUSH paintings, e.g. cracks, crazing, chalking, etc.?** (Select one option)

- Always
- Often
- Sometimes

Rarely
 Never

page 19

25. Please specify which deterioration type(s) in the paint film you [[check your answer to question number 24]] encountered [Answer this question only if answer to Q#24 is NOT (Never)]

page 20

*** 26. What was the dominant paint medium employed in the AIRBRUSH paintings on which you carried out technical examination/conservation treatment? (Select one option)**

Natural (e.g. oil, tempera)
 Synthetic (e.g. Acrylics)
 Other (please specify) _____

page 21

*** 27. How often do you encounter an existence of varnish layer in AIRBRUSH paintings? (Select one option)**

Always

- Often
- Sometimes
- Rarely
- Never

page 22

*** 28. You did not carry out conservation treatment before on AIRBRUSH paintings because:
(Select all that apply)**

[Answer this question only if answer to Q#17 is NOT (Yes)]

- I do not have a proper knowledge relevant to this type of paintings
- I just did not have the chance
- Other (please elaborate) _____

page 23

29. It will be very helpful for the researcher if you had any comments or thoughts you kindly would like to share. Please feel free to elaborate here on any of the responses you have given, or add any comment you think it can benefit the research:

page 24

*** 30. Do you wish to receive the final results of this survey? (Select one option)**

- Yes
- No

*** 31. Can the researcher contact you for further queries or information? (Select one option)**

- Yes
- No

If the answer was yes to one or both of the last two questions please provide your contact details below:

32. Your contact details:

(a)	Title	
		<hr/> <hr/>
(b)	Name	
		<hr/> <hr/>
(c)	Address 1	
		<hr/> <hr/>
(d)	Address 2	
		<hr/> <hr/>

(e)	City/Town
	<hr/> <hr/>
(f)	State/Province
	<hr/> <hr/>
(g)	Zip/Postal Code
	<hr/> <hr/>
(h)	Country (Select one option)
	<ul style="list-style-type: none"> <input type="radio"/> Afghanistan <input type="radio"/> Albania <input type="radio"/> Algeria <input type="radio"/> Andorra <input type="radio"/> Angola <input type="radio"/> Antigua and Barbuda <input type="radio"/> Argentina <input type="radio"/> Armenia <input type="radio"/> Australia <input type="radio"/> Austria <input type="radio"/> Azerbaijan <input type="radio"/> Bahamas

- Bahrain
- Bangladesh
- Barbados
- Belarus
- Belgium
- Belize
- Benin
- Bhutan
- Bolivia
- Bosnia
- Botswana
- Brazil
- Brunei
- Bulgaria
- Burkina Faso
- Burma
- Burundi
- Cambodia
- Cameroon
- Canada

- Cape Verde
- Central African Republic
- Chad
- Chile
- China
- Colombia
- Comoros
- Congo (Brazzaville)
- Congo (Kinshasa)
- Costa Rica
- Cote d'Ivoire
- Croatia
- Cuba
- Cyprus
- Czech Republic
- Denmark
- Djibouti
- Dominica
- Dominican Republic
- East Timor Timor Timur

- Ecuador
- Egypt
- El Salvador
- Equatorial Guinea
- Eritrea
- Estonia
- Ethiopia
- Fiji
- Finland
- France
- Gabon
- Gambia
- Georgia
- Germany
- Ghana
- Greece
- Grenada
- Guatemala
- Guinea
- Guinea-Bissau

- Guyana
- Haiti
- Holy See
- Honduras
- Hong Kong
- Hungary
- Iceland
- India
- Indonesia
- Iran
- Iraq
- Ireland
- Israel
- Italy
- Jamaica
- Japan
- Jordan
- Kazakhstan
- Kenya
- Kiribati

- Kosovo
- Kuwait
- Kyrgyzstan
- Laos
- Latvia
- Lebanon
- Lesotho
- Liberia
- Libya
- Liechtenstein
- Lithuania
- Luxembourg
- Macau
- Macedonia
- Madagascar
- Malawi
- Malaysia
- Maldives
- Mali
- Malta

- Marshall Islands
- Mauritania
- Mauritius
- Mexico
- Micronesia
- Moldova
- Monaco
- Mongolia
- Montenegro
- Morocco
- Mozambique
- Namibia
- Nauru
- Nepal
- Netherlands
- Netherlands Antilles
- New Zealand
- Nicaragua
- Niger
- Nigeria

- North Korea
- Norway
- Oman
- Pakistan
- Palau
- Palestinian Territories
- Panama
- Papua New Guinea
- Paraguay
- Peru
- Philippines
- Poland
- Portugal
- Puerto Rico
- Qatar
- Romania
- Russia
- Rwanda
- Saint Kitts and Nevis
- Saint Lucia

- Saint Vincent and the Grenadines
- Samoa
- San Marino
- Sao Tome and Principe
- Saudi Arabia
- Senegal
- Serbia
- Seychelles
- Sierra Leone
- Singapore
- Slovakia
- Slovenia
- Solomon Islands
- Somalia
- South Africa
- South Korea
- Spain
- Sri Lanka
- Sudan
- Suriname

- Swaziland
- Sweden
- Switzerland
- Syria
- Taiwan
- Tajikistan
- Tanzania
- Thailand
- Timor-Leste
- Togo
- Tonga
- Trinidad and Tobago
- Tunisia
- Turkey
- Turkmenistan
- Tuvalu
- Uganda
- Ukraine
- United Arab Emirates
- United Kingdom

	<input type="radio"/> United States of America <input type="radio"/> Uruguay <input type="radio"/> Uzbekistan <input type="radio"/> Vanuatu <input type="radio"/> Venezuela <input type="radio"/> Vietnam <input type="radio"/> Yemen <input type="radio"/> Zambia <input type="radio"/> Zimbabwe
(i)	Telephone
	<hr/> <hr/>
(j)	Mobile no.
	<hr/> <hr/>
(k)	Email Address
	<hr/> <hr/>

A.1.2 Tables and Charts of the Responses to Questionnaire 1

A.1.2.1 The demographic profile of respondents:

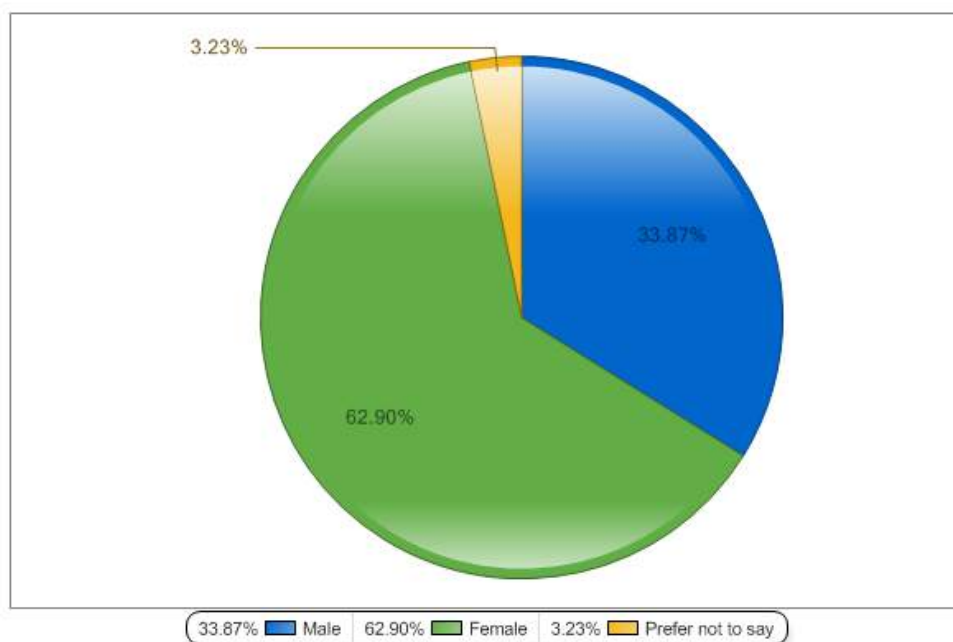

Figure 98: a pie chart illustrating ratio proportions of respondents according to gender

Table 9: distribution of respondents by gender

Gender		
Responses	Count	Ratio
Male	21	33.87%
Female	39	62.90%
Prefer not to say	2	3.23%
Total Responses	62	

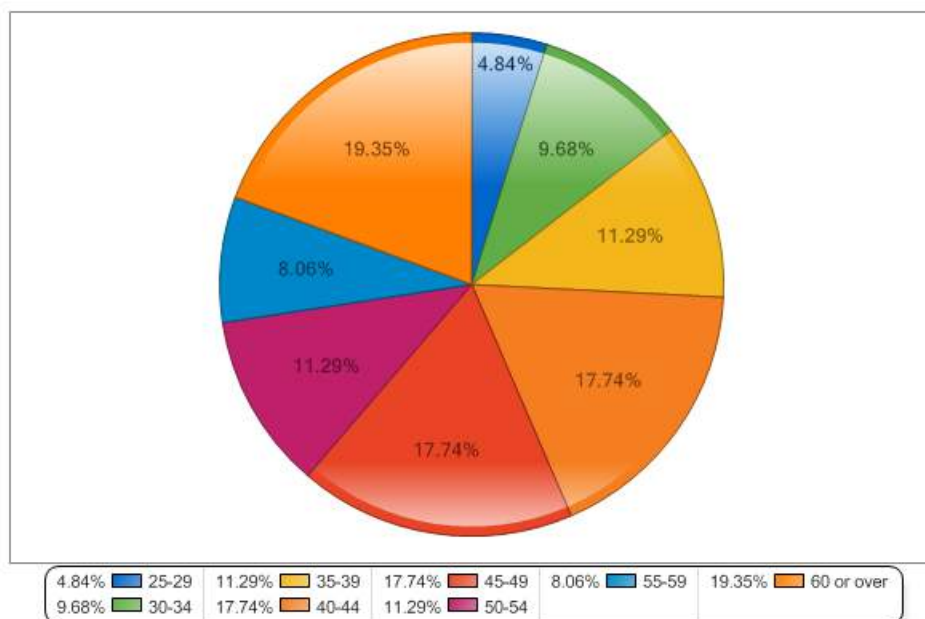

Figure 99: a pie chart illustrating ratio proportions of respondents according to age group

Age group		
Responses	Count	Ratio
19 or under	0	0%
20-24	0	0%
25-29	3	4.84%
30-34	6	9.68%
35-39	7	11.29%
40-44	11	17.74%
45-49	11	17.74%
50-54	7	11.29%
55-59	5	8.06%
60 or over	12	19.35%
Total Responses	62	

Table 10: distribution of respondents by age group

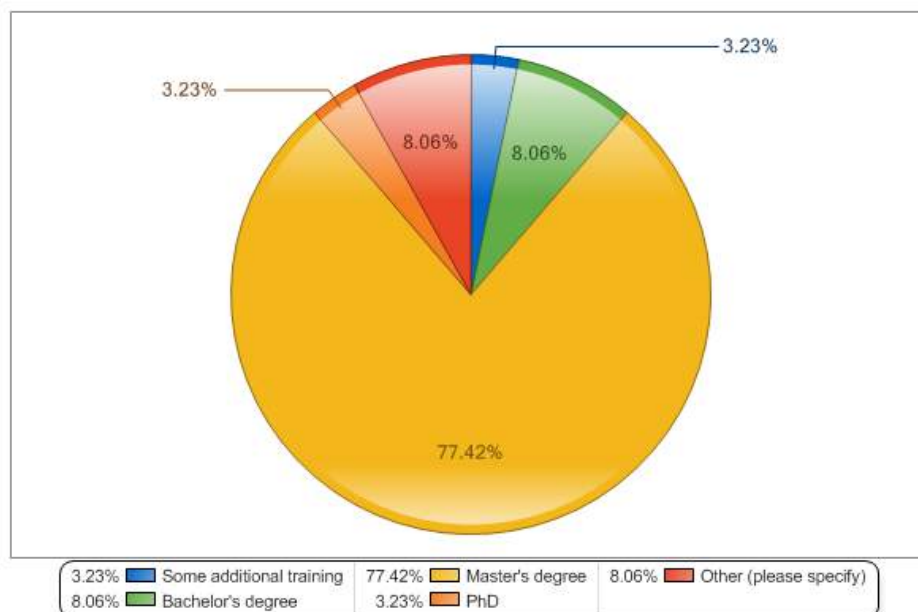

Figure 100: a pie chart illustrating ratio proportions of respondents according to gender

Highest level of education completed		
Responses	Count	Ratio
Some School	0	0%
Higher Secondary	0	0%
Some College	0	0%
Some additional training	2	3.23%
Bachelor's degree	5	8.06%
Master's degree	48	77.42%
PhD	2	3.23%
Other (please specify)	5	8.06%
Total Responses	62	

Table 11: distribution of respondents by highest level of education

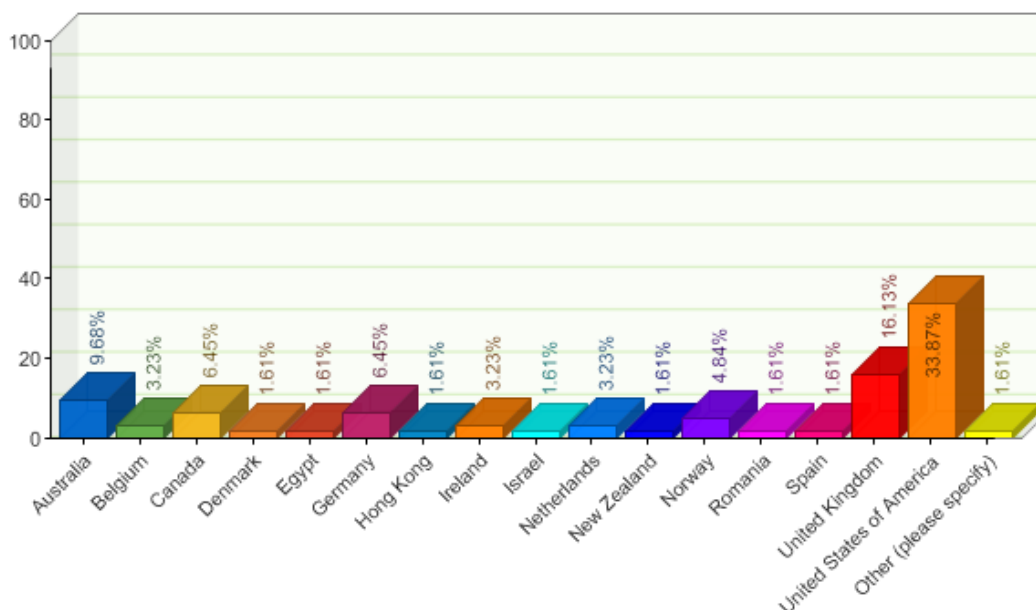

Figure 101: a bar graph illustrating ratio proportions of respondents according to country of residence

Country of residence		
Responses	Count	Ratio
Australia	6	9.68%
Belgium	2	3.23%
Canada	4	6.45%
Denmark	1	1.61%
Egypt	1	1.61%
Germany	4	6.45%
Hong Kong	1	1.61%
Ireland	2	3.23%
Israel	1	1.61%
Netherlands	2	3.23%
New Zealand	1	1.61%
Norway	3	4.84%
Romania	1	1.61%
Spain	1	1.61%
United Kingdom	10	16.13%
United States of America	21	33.87%
Other (please specify)	1	1.61%
Total Responses	62	

Table 12: distribution of respondents by country of residence

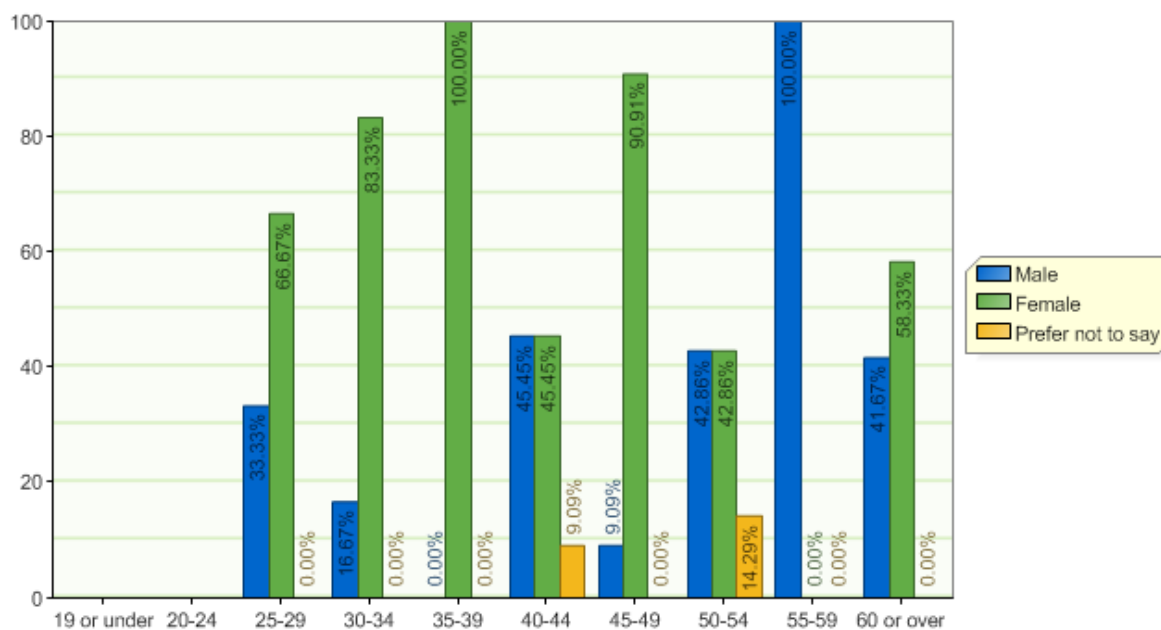

Figure 102: a bar graph illustrating ratio proportions of respondents according to gender and age group

Horizontal: Gender / Vertical: Age group												
Ver. Hori.		19 or under	20-24	25-29	30-34	35-39	40-44	45-49	50-54	55-59	60 or over	Total
Male	Count	0	0	1	1	0	5	1	3	5	5	21
	Ratio	0%	0%	4.7 6%	4.7 6%	0%	23.8 1%	4.76 %	14.2 9%	23.8 1%	23.8 1%	100.0 0%
Female	Count	0	0	2	5	7	5	10	3	0	7	39
	Ratio	0%	0%	5.1 3%	12.8 32%	17.9 45%	12.8 32%	25.6 65%	7.69 19%	0%	17.9 45%	100.0 0%
Prefer not to say	Count	0	0	0	0	0	1	0	1	0	0	2
	Ratio	0%	0%	0%	0%	0%	50.0 0%	0%	50.0 0%	0%	0%	100.0 0%
Total	Count	0	0	3	6	7	11	11	7	5	12	62
	Ratio	0%	0%	4.8 4%	9.6 8%	11.2 9%	17.7 4%	17.7 4%	11.2 9%	8.06 %	19.3 5%	100.0 0%

Table 13: distribution of respondents by gender and age group

A.1.2.2 Career-related questions:

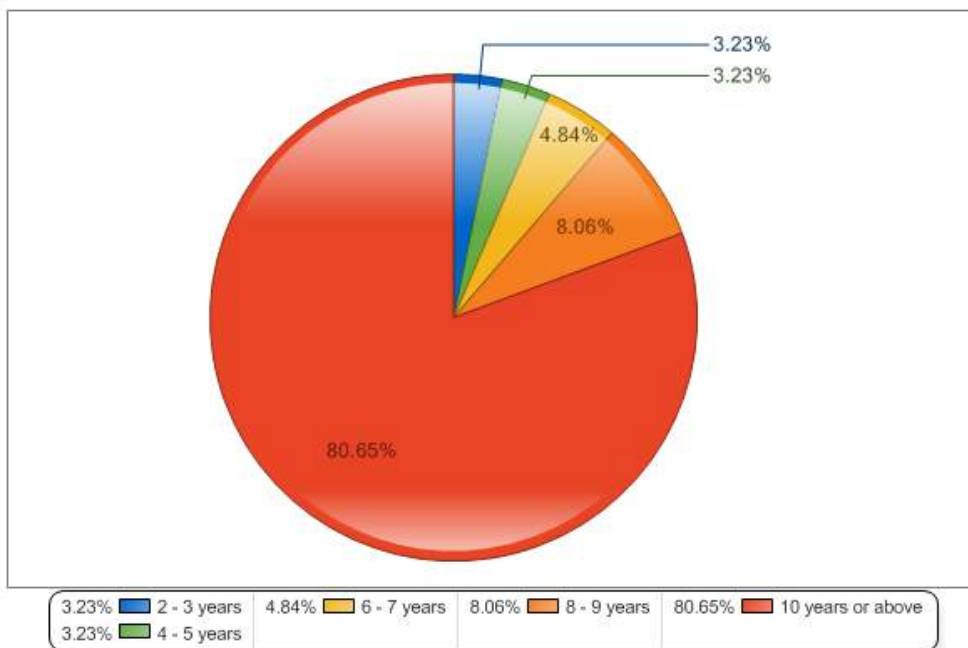

Figure 103: a pie chart illustrating ratio proportions of respondents according to their years of experience

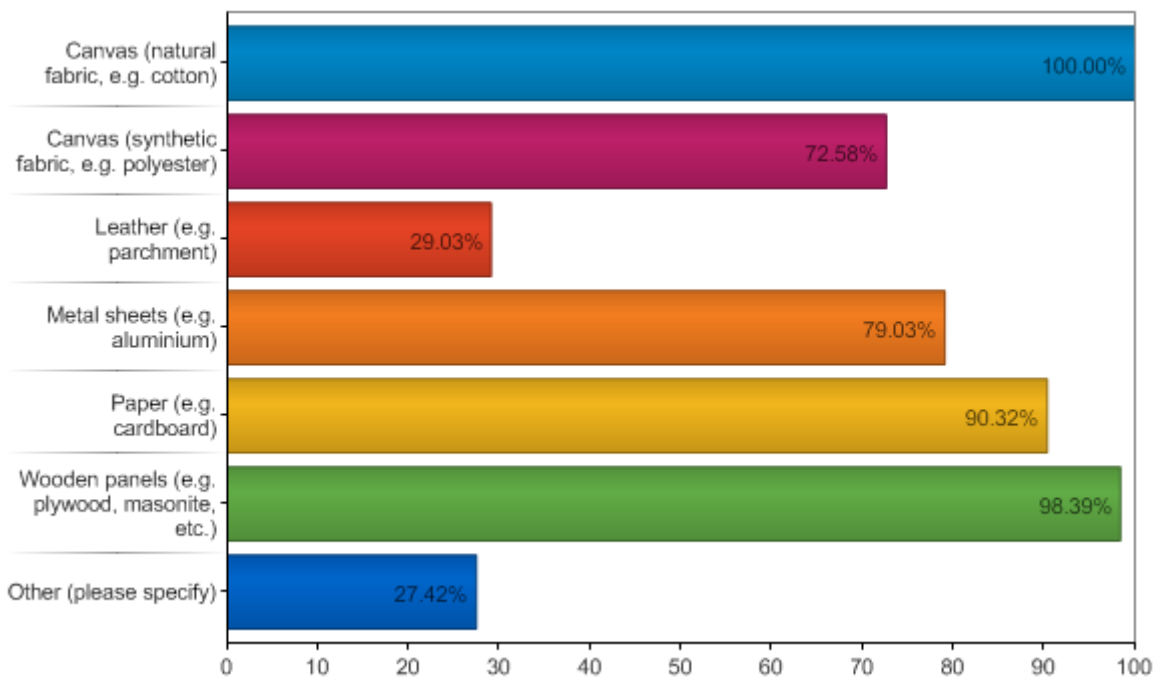

Figure 104: a range chart illustrating ratio proportions of respondents according to their experience in different painting supports

A.1.2.3 Attitudinal questions:

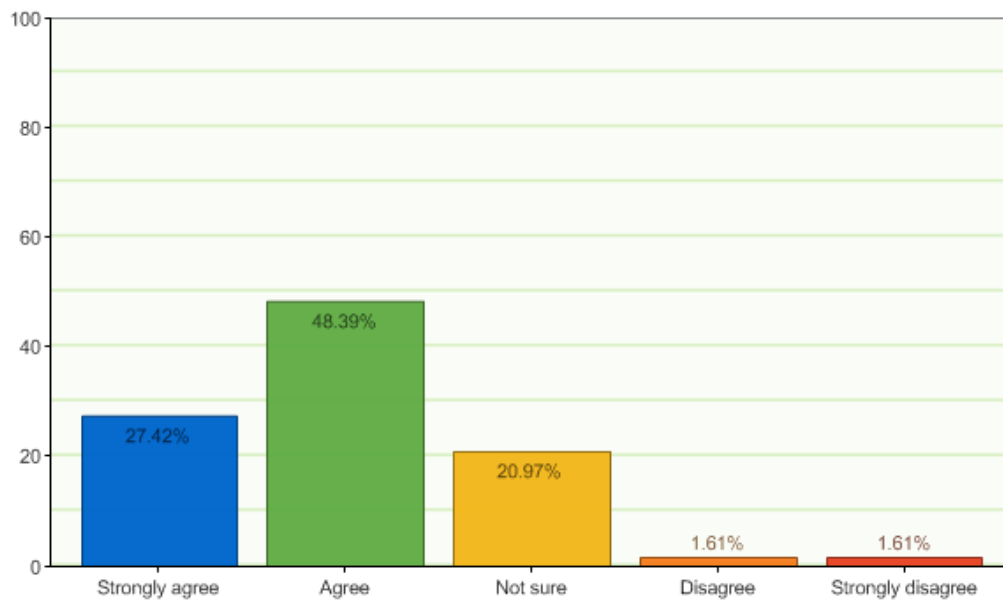

Figure 105: a vertical bar graph illustrating ratio proportions of respondents according to their degree of acceptance of the airbrush as a tool for fine art paintings

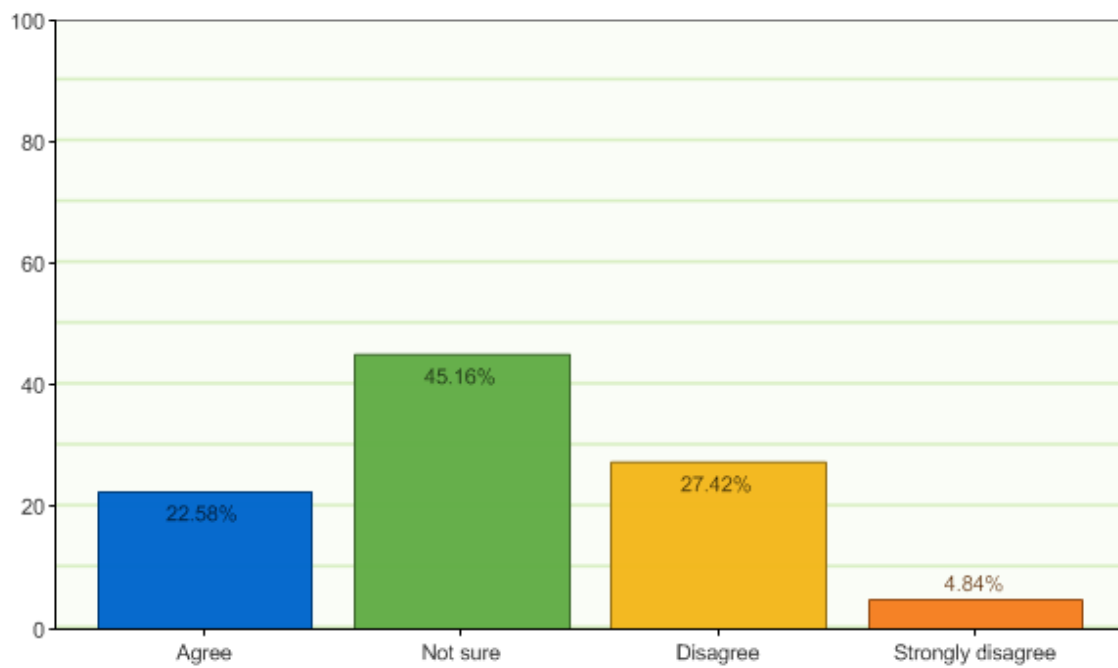

Figure 106: a vertical bar graph illustrating ratio proportions of respondents according to their opinion about the degree of acceptance of the airbrush, in fine art circles, as a tool for fine art paintings

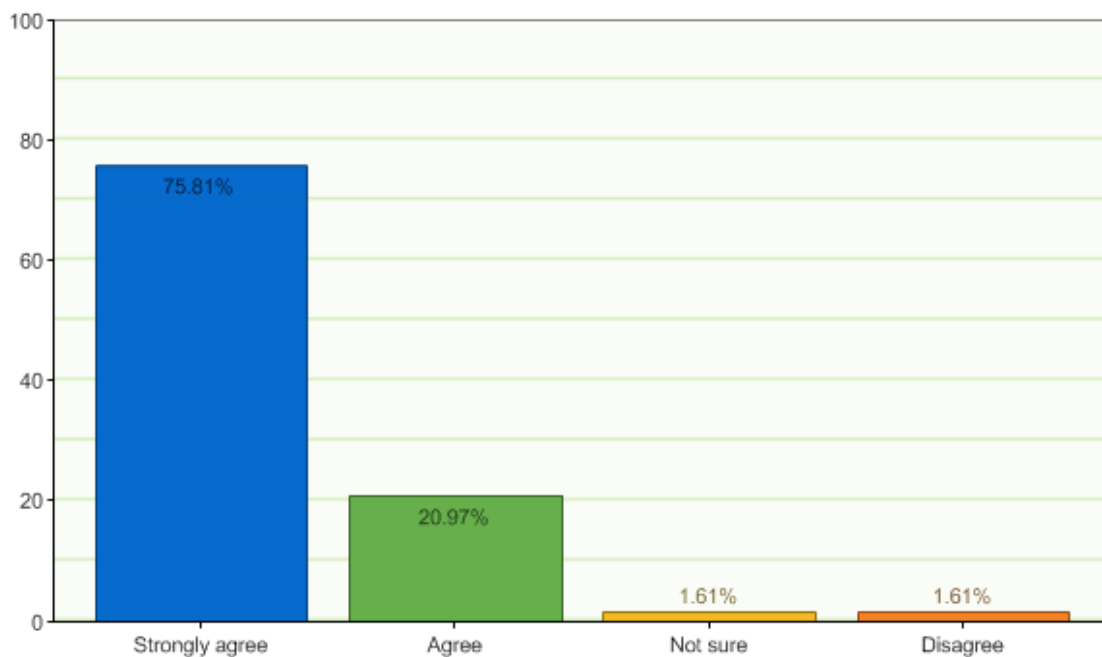

Figure 107: a vertical bar graph illustrating ratio proportions of respondents according to their opinion about the possibility that paint application techniques affect the condition of paintings

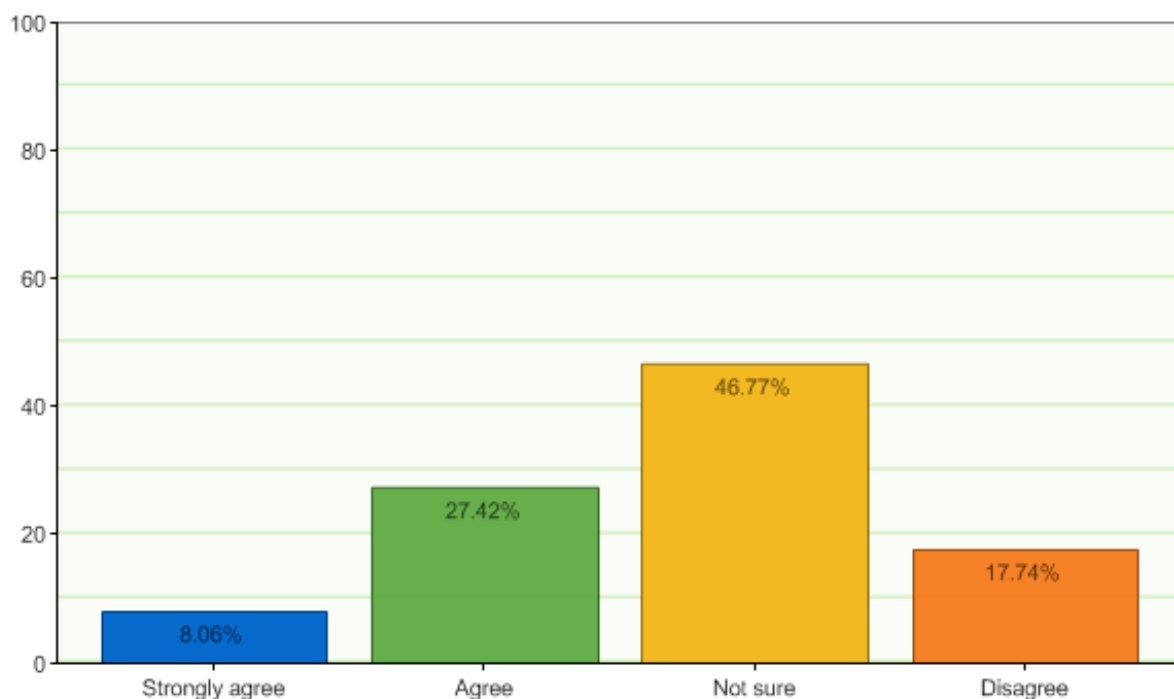

Figure 108: a vertical bar graph illustrating ratio proportions of respondents according to their opinion whether art conservators are knowledgeable about problems that might be directly related to paintings executed with airbrushing techniques

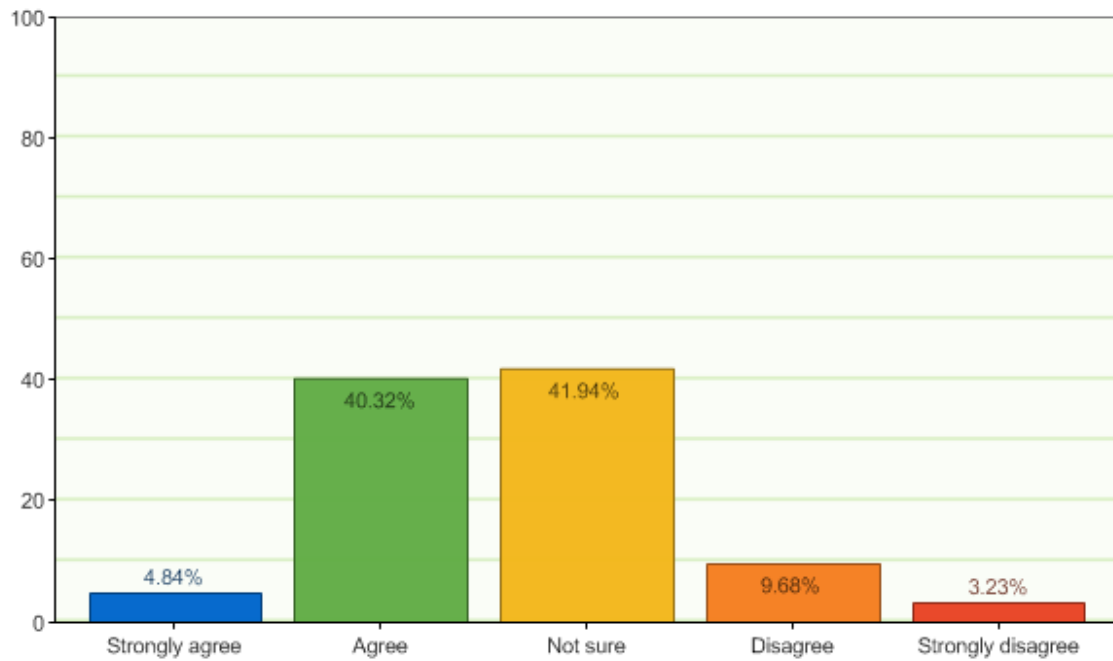

Figure 109: a vertical bar graph illustrating ratio proportions of respondents according to their opinion whether art conservators are unknowledgeable about problems that might be directly related to paintings executed with airbrushing techniques

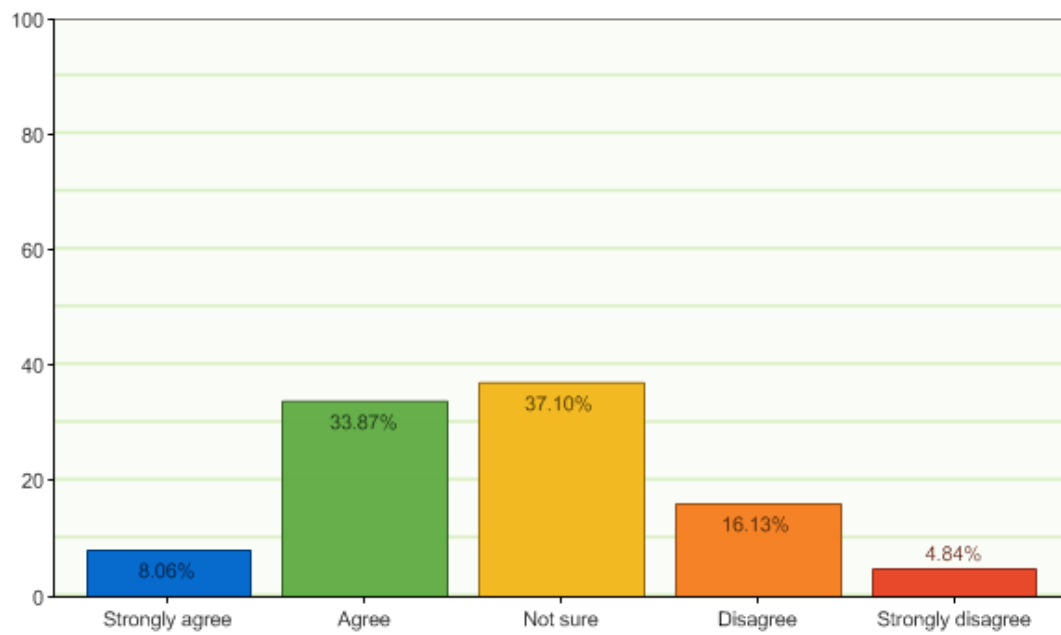

Figure 110: a vertical bar graph illustrating ratio proportions of respondents according to their opinion whether they have a clear idea of the conservation treatment they may safely use in airbrush paintings that require image reintegration

A.1.2.4 Branching Question:

Have you ever, throughout your career, encountered airbrush easel paintings that had to undergo any type of conservation treatment?		
Responses	Count	%
Yes	36	58.06%
No	26	41.94%
Total Responses	62	100%

Table 14: distribution of respondents according to their direct experience with airbrush paintings

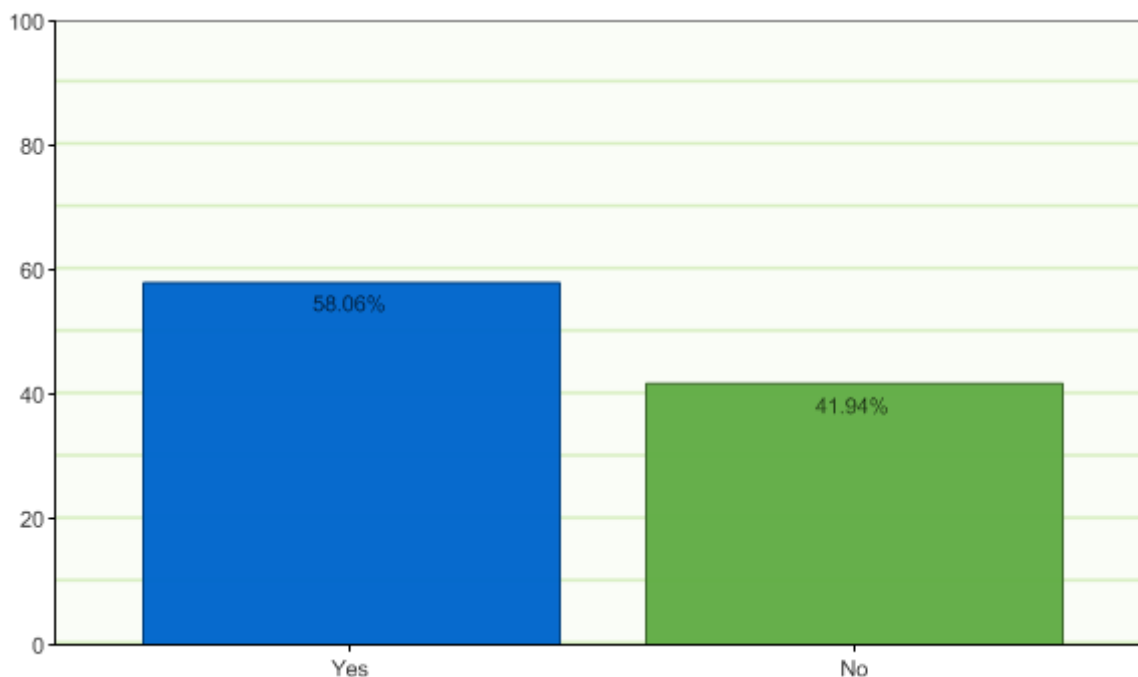

Figure 111: a vertical bar graph illustrating ratio proportions of respondents according to their direct experience with airbrush paintings

A.1.2.5 *Questions only related to respondents with direct experience in airbrush easel paintings:*

In general, there can be conservation problems in airbrush paintings different from those in the paintings executed with other paint application types.		
Responses	Count	%
Strongly agree	8	22.22%
Agree	20	55.56%
Not sure	6	16.67%
Disagree	1	2.78%

Strongly disagree	1	2.78%
Total Responses	36	

Table 15: distribution of respondents according to their opinion whether conservation problems in airbrush paintings are different from those in paintings executed with other paint application types.

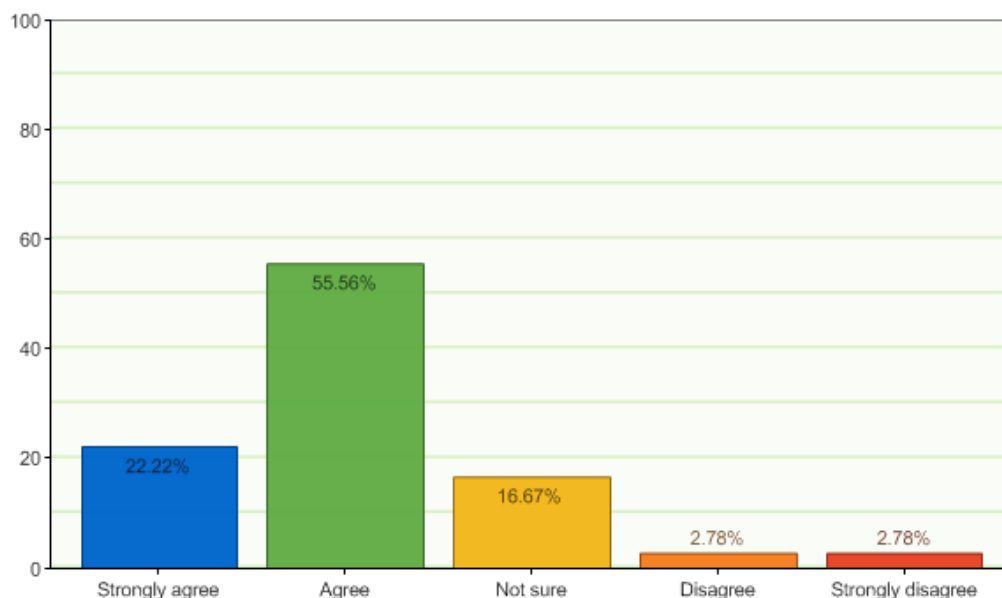

Figure 112: a vertical bar graph illustrating ratio proportions of respondents according to their opinion whether conservation problems in airbrush paintings are different from those in paintings executed with other paint application types.

Which procedure you found that airbrush paintings often require? (Select all that apply)		
Responses	Count	%
Technical examination	19	52.78%
Preventive conservation	21	58.33%
Structural work (e.g. tear mending, lining)	12	33.33%
Cleaning (e.g. dirt removal, varnish removal)	26	72.22%
Image reintegration (e.g. filling, retouching)	24	66.67%
Nothing significant than other types of paintings	16	44.44%
Other (please specify)	6	16.67%
Total Responses	124	

Table 16: distribution of respondents according to their experience with the conservation treatments and procedures that airbrush paintings often require. Please note that multiple answers per participant exist. Percentages added exceed 100 since a participant may select more than one answer for this question.

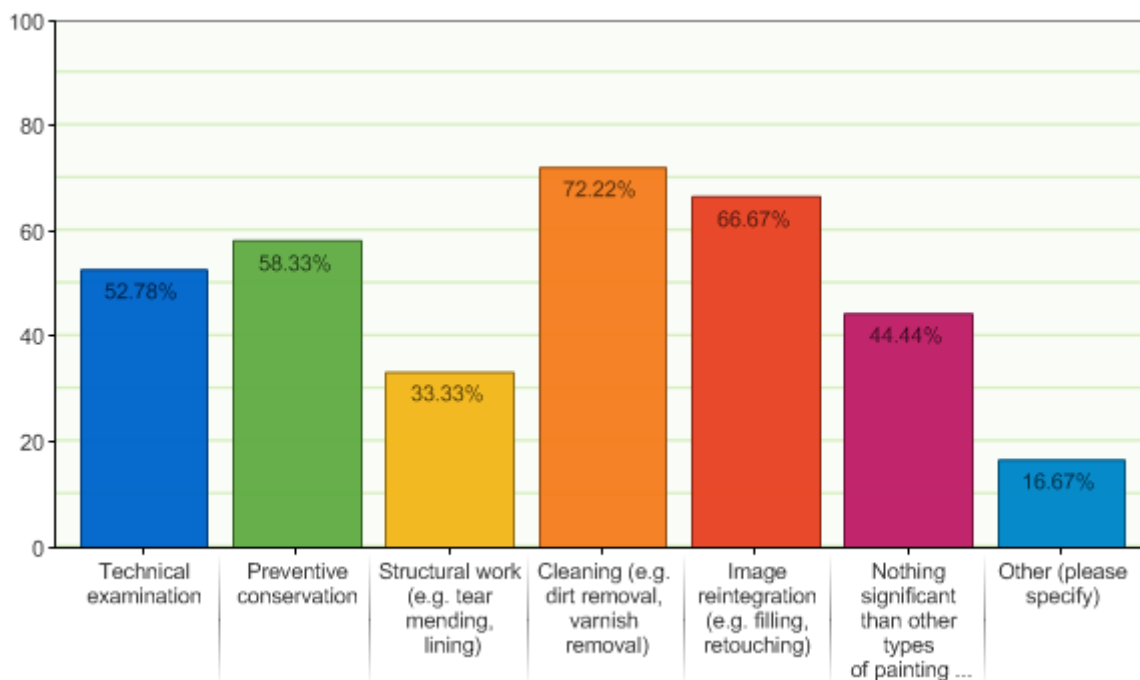

Figure 113: a vertical bar graph illustrating ratio proportions of respondents according to their experience with the conservation treatments and procedures that airbrush paintings often require

Comparing to other types of paintings, the thickness of the ground layer in airbrush paintings is generally:		
Responses	Count	%
Greater	1	2.78%
Lesser	10	27.78%
Not really different	13	36.11%
I am not sure	3	8.33%
Other (please specify)	9	25.00%
Total Responses	36	

Table 17: distribution of respondents according to their experience with the thickness of the ground layer in airbrush paintings comparing to other types of paintings

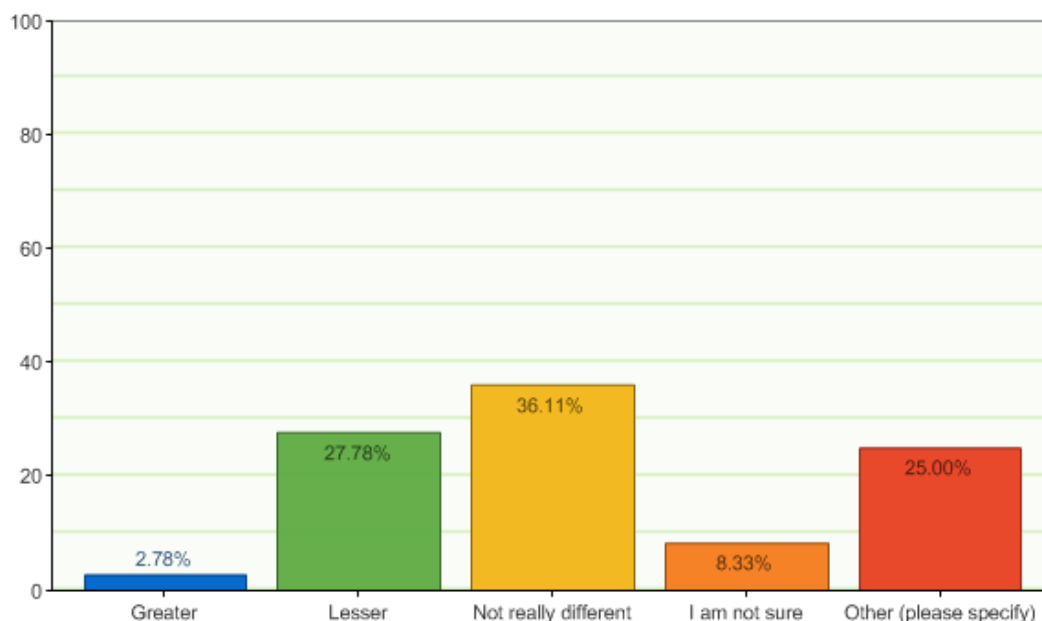

Figure 114: a vertical bar graph illustrating ratio proportions of respondents according to their experience with the thickness of the ground layer in airbrush paintings comparing to other types of paintings

Comparing to other types of paintings, the thickness of the paint film in airbrush paintings is generally:		
Responses	Count	%
Greater	0	0%
Lesser	29	80.56%
Not really different	1	2.78%
I am not sure	0	0%
Other (please specify)	6	16.67%
Total Responses	36	

Table 18: distribution of respondents according to their experience with the thickness of the paint film in airbrush paintings comparing to other types of paintings

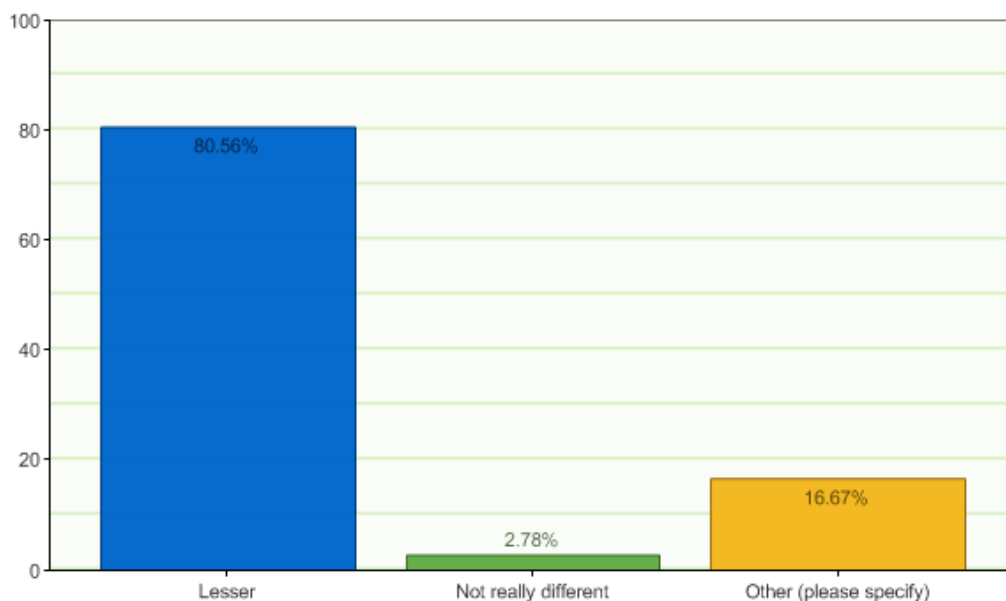

Figure 115: a vertical bar graph illustrating ratio proportions of respondents according to their experience with the thickness of the paint film in airbrush paintings comparing to other types of paintings

How often do you encounter deterioration problems in the paint film in airbrush paintings, e.g. cracks, crazing, chalking, etc.?		
Responses	Count	%
Always	0	0%
Often	4	11.11%
Sometimes	18	50.00%
Rarely	11	30.56%
Never	3	8.33%
Total Responses	36	

Table 19: distribution of respondents according to their experience with the deterioration problems that they might have encountered in the paint film in airbrush paintings

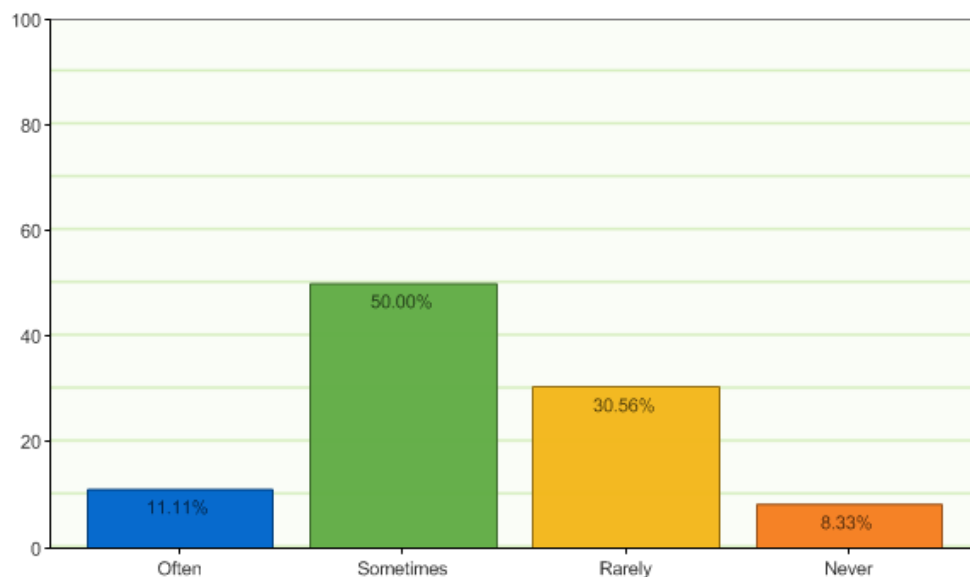

Figure 116: a vertical bar graph illustrating ratio proportions of respondents according to their experience with the deterioration problems that they might have encountered in the paint film in airbrush paintings

What was the dominant paint medium employed in the airbrush paintings on which you carried out technical examination/conservation treatment?		
Responses	Count	%
Natural (e.g. oil, tempera)	4	11.11%
Synthetic (e.g. Acrylics)	27	75.00%
Other (please specify)	5	13.89%
Total Responses	36	

Table 20: distribution of respondents according to which of the paint mediums was dominantly employed in airbrush paintings they encountered

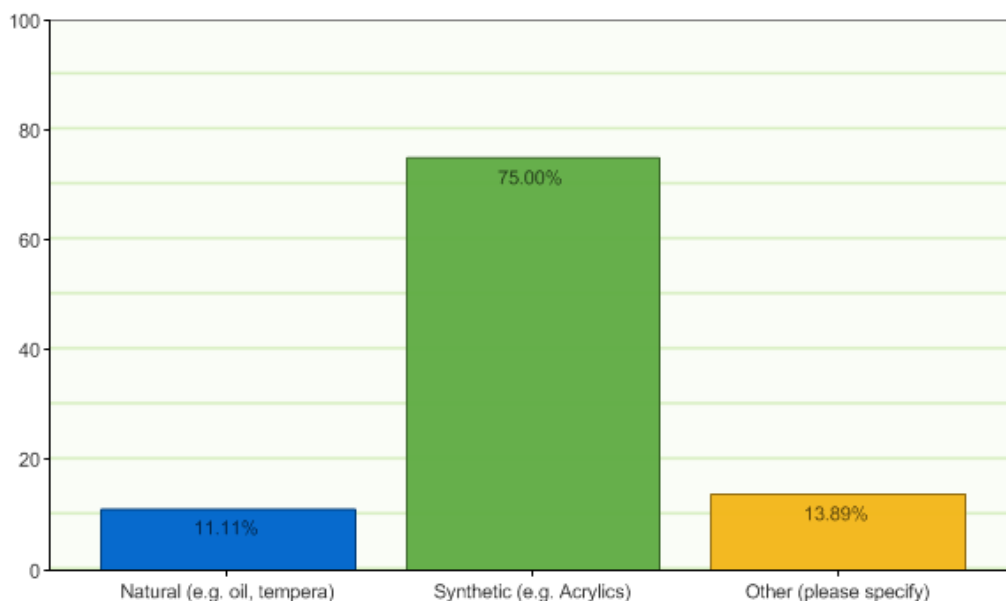

Figure 117: a vertical bar graph illustrating ratio proportions of respondents according to which of the paint mediums was dominantly employed in airbrush paintings they encountered

How often do you encounter an existence of varnish layer in airbrush paintings?		
Responses	Count	%
Always	0	0%
Often	1	2.78%
Sometimes	13	36.11%
Rarely	12	33.33%
Never	10	27.78%
Total Responses	36	

Table 21: distribution of respondents according to how often they encountered an existence of varnish layer in airbrush paintings

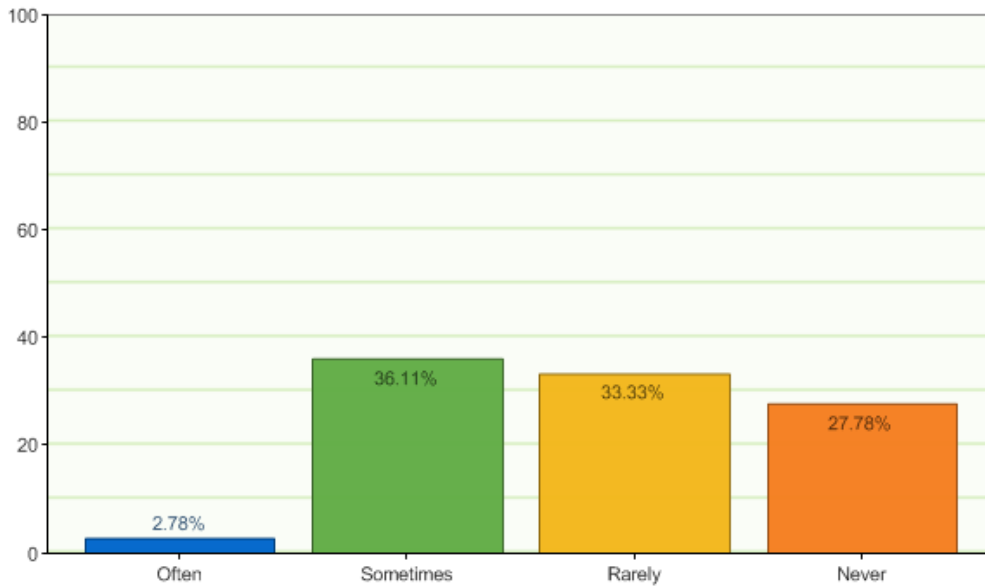

Figure 118: a vertical bar graph illustrating ratio proportions of respondents according to how often they encountered an existence of varnish layer in airbrush paintings

A.1.2.6 Open-ended questions:

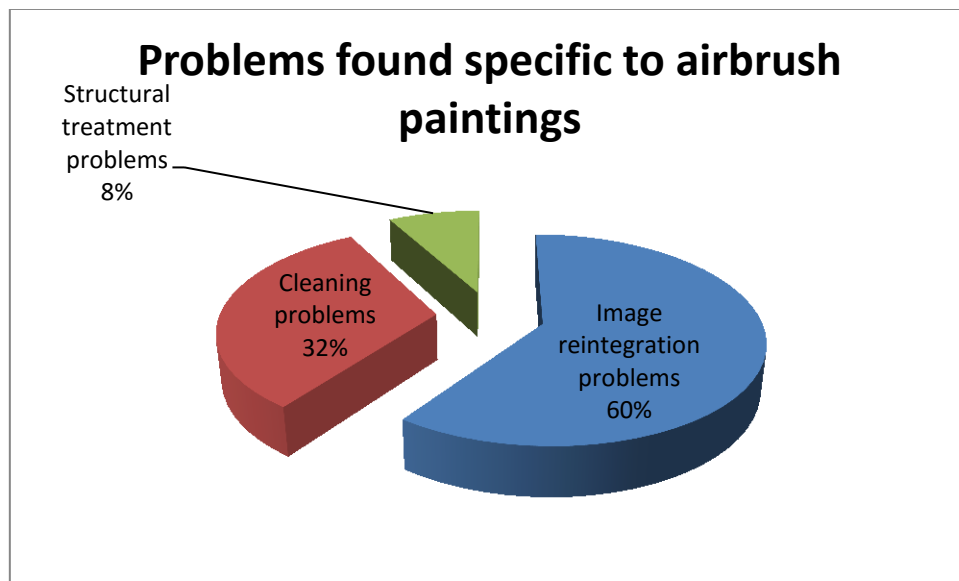

Figure 119: a pie chart illustrating ratio proportions of, in respondents' opinions, problems found specific to airbrush paintings according to numerical data extracted from verbatim responses.

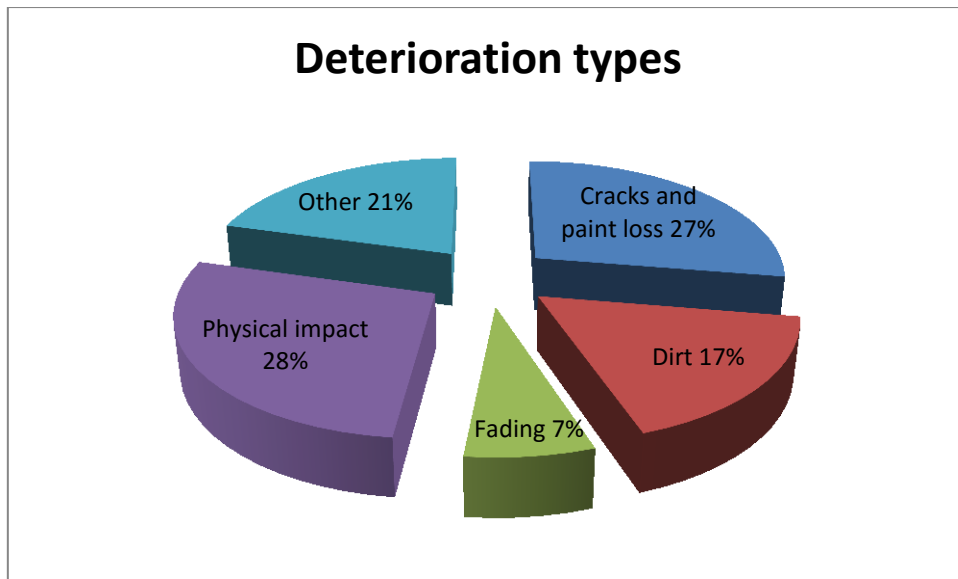

Figure 120: a pie chart illustrating ratio proportions of, in respondents' opinions, deterioration type(s) in the paint films of airbrush paintings they encountered according to numerical data extracted from verbatim responses.

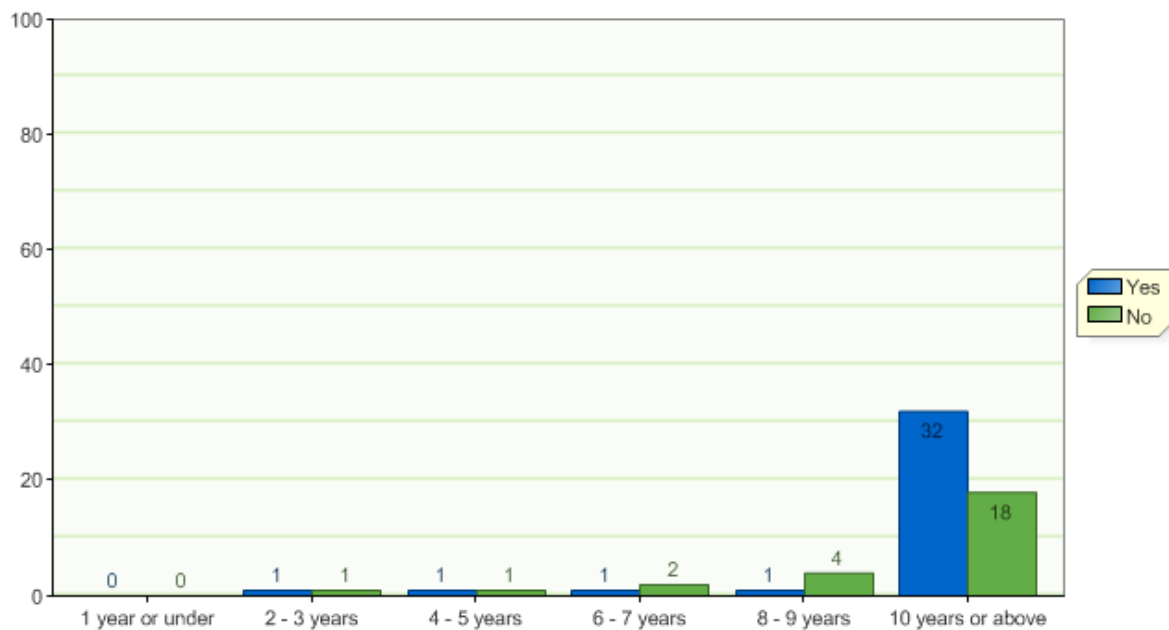

Figure 121: a vertical bar graph illustrating the count of respondents according to their direct experience in the conservation treatment of airbrush paintings compared to their total level of experience in the field of the conservation of fine art. Noticeably, the majority of conservators who participated in this survey and indicated that they have direct experience in the conservation of airbrush paintings have 10 years or above of experience in their field.

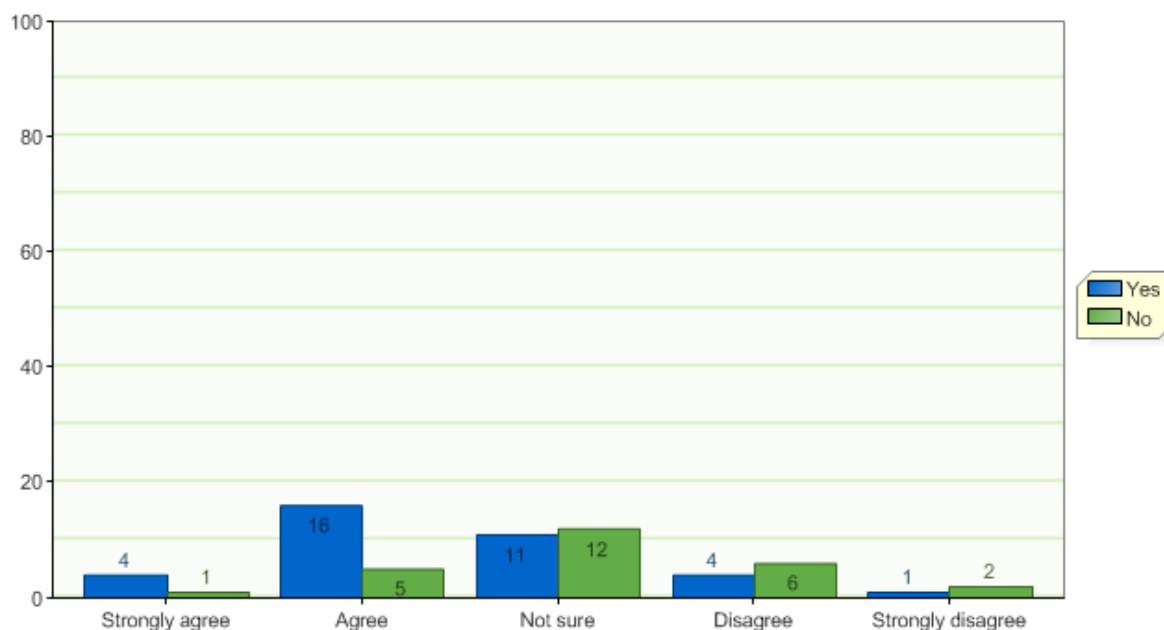

Figure 122: a vertical bar graph illustrating the count of respondents according to their degree confidence to carry out image reintegration in airbrush paintings, compared to their actual experience with the conservation treatment of airbrush paintings. Interestingly, six respondents believe they have a clear idea of the conservation treatment you may safely use if they have an airbrush painting that needs image reintegration, despite they stated that they have never worked on airbrush paintings. On the other hand, there are other five respondents who indicated that they do not have a clear idea of such a conservation treatment, although they stated that they actually worked on airbrush paintings.

A.1.2.7 Verbatim responses to Questionnaire 1:

Table 22: the table shows the verbatim responses to the open ended questions no. 20, 25 and 29 of the questionnaire aimed at art conservators

Questions	Q.20	Q.25	Q.29
Answers	Please provide further details about problem(s) you have found specific to airbrush paintings	Please specify which deterioration type(s) in the paint film you encountered	Please feel free to elaborate here or add any comment you think it can benefit the research
1			
2			The questions in the survey are very generalised and poorly thought out. I suggest you find a conservator experienced with such work and consult them first. Perhaps private conservators in London or New York who specialise in modern and contemporary work as a starting point.

3			
4	Even surface application of retouching or in painting. Actual spray colour matching as the colour tends to change on drying.	Staining	
5	the same problems as with regular easel paintings	flaking and blistering	
6			
7	problems with reintergrating the surfaces and not overpainting when reintergrating		
8	quality of particles, those can be bigger or finer. hard to match sometimes	cracks	I don't think it acceptable airbrush in paintings unless the paintings has been air brushed.
9	Retouching these paintings can be particularly problematic. Integrating design and structural deformations must be done in an extremely sensitive manner.	cracking, delamination	
10	layering, sensitivities to cleaning both with aqueous and solvent based solutions as well as the mechanical impact during cleaning.		
11	Rather than pigment/binder systems applied using a brush or some other film-forming application method, airbrush is capable of a range of application textures and surfaces, graded tonal transitions of great finesse, and often present and slightly textured, multi-layered laminates characterized by irregular and intermittent continuity.	Airbrushed paint systems, not having experienced a long-term track record as a fine art medium, are subject to alterations by the artist to achieve desired working properties, without regard to the long-term impact of the choice making that surrounds these alterations. Over-thinning, combinations of incompatible media, pigments or solvents can contribute to less-than-ideal aging overtime.	
12	utter lack of surface texture (impasto), hyper-precision of surface gloss, uniformity of tone, frequently done on slick or smooth surfaces	flaking, chalking, mould	Particularly with airbrushed paintings on flat (wood, metal) supports, I have found that it is almost essential to polish or otherwise sand an airbrushed surface to get a perfectly level fill. In-

			painting inevitably involves a certain amount of over-painting. In other words, it is necessary to violate standards of practice common with traditional easel paintings if one wants to achieve an invisible repair.
13	difficult to inpaint - matching the pattern of paint application is very problematic	Again, I've worked on so few, I don't have an opinion.	
14	surface light reflectance is different: difficult to do inpainting Difficulty to clean surface		Preventive conservation is the key to avoid any treatment of these difficult to treat paintings.
15		Advanced structural problems: cracking due to thick paint application.	My treatment of airbrush paintings is very limited. I think I've only encountered it one or two times, generally as part of another paint application, such as brush. Never have I worked on an entirely airbrushed work.
16			
17			
18		Cracking transfered from substrate; scuffing & scratching; paint loss associated with damage to the support; discolouration from contact with other material; imbibing of surface dirt	The airbrush techniques I have encountered have always been part of the technique of paint application in an image, with other more 'traditional' forms of application also present. I have never encountered a painting where airbrush techniques have been used as the technique for application of the whole image.
19			These type of surfaces are very susceptible to damage due to the low medium content. Masking off would be a necessity to carry out any type of treatment.
20	Usually minor areas of scratches etc. Never a large area of loss.....yet.	scratches, accretions, traction cracquelure	It would be interesting to suggest a varnish that would be compatible with airbrush - to share this with artists. Good luck with your research - am sure it will be

			helpful to the conservation community.
--	--	--	--

A.1.3 Questionnaire 2: A Survey on Airbrush Easel Painting in the Context of Fine Art

This questionnaire was built on and distributed via sogosurvey.com. It is intended to be completed online via invitation only.

* Required Information

page 1
<p style="text-align: center;">A Survey on Airbrush Easel Painting in the Context of Fine Art</p> <p>Hello, Thank you in advance for taking the time to fill in this survey regarding the use of airbrushing techniques in easel paintings. This survey is aimed at fine artists who are specialised in easel paintings and will take approximately 10 minutes to be completed. Your participation in this study is voluntary. There are no foreseeable risks associated with this project. However, please be assured that your personal information will be strictly confidential. Please note the following: - Only use the Back or Next buttons below each page. Please do NOT use the navigation buttons of your browser otherwise all data you entered may be lost. - This survey restricts the participant to only one response. You can NOT participate in this survey more than once. However, you may save and continue later if you wish. - Your survey timeout is set to 60 minutes of inactivity. If you leave this survey inactive for this duration, all your previous answers may be lost. If you have questions at any time about the survey or the procedures, you may contact me by email at: mohamed.abdeldayem@northumbria.ac.uk Or by writing to the following address: Mohamed Abdeldayem Soltan Glenamara Centre School of Arts and Social Sciences Northumbria University Newcastle upon Tyne, UK NE1 8ST Please start with the survey now by clicking on the Next button below.</p>

page 2
* 1. You are: (Select one option)
<input type="radio"/> Male
<input type="radio"/> Female

Prefer not to say

*** 2. Your age group is: (Select one option)**

19 or under 20-24 25-29 30-34 35-39

40-44 45-49 50-54 55-59 60 or over

*** 3. What is the highest level of education that you have completed? (Select one option)**

Some School

Higher Secondary

Some College

Some additional training

Bachelor's degree

Master's degree

PhD

Other (please specify) _____

*** 4. What is your nationality(ies)? (Select all that apply)**

Afghanistan

Albania

- Algeria
- Argentina
- Armenia
- Australia
- Austria
- Azerbaijan
- Bahrain
- Bangladesh
- Belarus
- Belgium
- Brazil
- Brunei
- Cambodia
- Canada
- China
- Colombia
- Costa Rica
- Croatia
- Cuba
- Cyprus

Czech Republic

Denmark

Egypt

Ethiopia

Finland

France

Georgia

Germany

Greece

Hong Kong

India

Indonesia

Iran

Iraq

Ireland

Israel

Italy

Japan

- Jordan
- Kazakhstan
- Kenya
- Korea, South
- Kuwait
- Lebanon
- Libya
- Malaysia
- Maldives
- Mauritius
- Mexico
- Morocco
- Myanmar
- Nepal
- Netherlands

New Zealand

Nigeria

Norway

Oman

Pakistan

Philippines

Poland

Portugal

Qatar

Romania

Russia

Saudi Arabia

Singapore

Slovakia

Slovenia

- Somalia
- South Africa
- Spain
- Sri Lanka
- Sudan
- Sweden
- Switzerland
- Syria
- Taiwan
- Tajikistan
- Thailand
- Tunisia
- Turkey
- Ukraine
- United Arab Emirates

- United Kingdom
- United States of America
- Uzbekistan
- Yemen
- Zambia
- Zimbabwe
- Other (please specify) _____

*** 5. Where are you currently live? (Select one option)**

- Afghanistan
- Albania
- Algeria
- Argentina
- Armenia
- Australia
- Austria

- Azerbaijan
- Bahrain
- Bangladesh
- Belarus
- Belgium
- Brazil
- Brunei
- Cambodia
- Canada
- China
- Colombia
- Costa Rica
- Croatia
- Cuba
- Cyprus
- Czech Republic

Denmark

Egypt

Ethiopia

Finland

France

Georgia

Germany

Greece

Hong Kong

India

Indonesia

Iran

Iraq

Ireland

Israel

Italy

- Japan
- Jordan
- Kazakhstan
- Kenya
- Korea, South
- Kuwait
- Lebanon
- Libya
- Malaysia
- Maldives
- Mauritius
- Mexico
- Morocco
- Myanmar
- Nepal
- Netherlands

New Zealand

Nigeria

Norway

Oman

Pakistan

Philippines

Poland

Portugal

Qatar

Romania

Russia

Saudi Arabia

Singapore

Slovakia

Slovenia

Somalia

- South Africa
- Spain
- Sri Lanka
- Sudan
- Sweden
- Switzerland
- Syria
- Taiwan
- Tajikistan
- Thailand
- Tunisia
- Turkey
- Ukraine
- United Arab Emirates
- United Kingdom
- United States of America

Uzbekistan
 Yemen
 Zambia
 Zimbabwe
 Other (please specify) _____

page 3

*** 6. Your art is your main source of income?** (Select one option)

- Yes
 No

*** 7. Other than being an artist, what is your occupation (if applicable)?** (Select one option)

- Accountant
 Consultant
 Customer Service / Support
 Educationist / Trainer

- Engineer
- Fashion Designer and others
- Government Employee - Central / Federal
- Government Employee - State
- Government Employee - City / Town
- Homemaker / Housewife
- Journalist / PR professional
- Legal-Lawyer
- Legal-Judge
- Legal-Others
- Manufacturer
- Medical-Doctor
- Medical-Nurse
- Medical-Others
- Office Staff - Secretary / Clerical / Receptionist / etc
- Pharmaceutical professional

- Researcher / Scientist
- Retired
- Sales / Marketing / Advertising professional
- Self-employed / Business Owner
- Student
- Software professional
- Technical staff
- Tradesman / Craftsman
- Unemployed
- Not applicable
- Other (please specify) _____

*** 8. In average, for how much your paintings are sold? (Select one option)**

- Less than \$100
- \$100 - \$500
- \$600 - \$1000

- \$1100 - \$1500
- \$1600 - \$2000
- \$2100 or above
- I did not sell any

*** 9. What is your annual income? (Select one option)**

- Less than \$20,000
- \$20,000 - \$40,999
- \$50,000 - \$70,999
- \$80,000 - \$100,999
- \$101,000 and above
- I prefer not to say

*** 10. In average, what is the size you prefer for your paintings? (Select one option)**

- Less than 50cm²
- 50 - 100cm²

150 - 200cm²
 250 - 300cm²
 350cm² or above
 This greatly varies

page 4

*** 11. In general, would you say your health is:** (Select one option)

- Excellent
 Very good
 Good
 Fair
 Poor

*** 12. Do you have chronic health issues?** (Select all that apply)

- Non
 Asthma

<input type="checkbox"/>	Chest pain
<input type="checkbox"/>	Chest tightness at rest or with Exertion
<input type="checkbox"/>	Chronic cough
<input type="checkbox"/>	Chronic Ear or Sinus Pain
<input type="checkbox"/>	Diabetes
<input type="checkbox"/>	Dizziness or Vertigo
<input type="checkbox"/>	Fatigue
<input type="checkbox"/>	Headaches
<input type="checkbox"/>	Hearing Loss
<input type="checkbox"/>	Pain in muscles or joint
<input type="checkbox"/>	Shortness of Breath
<input type="checkbox"/>	Shortness of Breath only with Exertion
<input type="checkbox"/>	Vision impairment
<input type="checkbox"/>	Weakness of Arm or Leg
<input type="checkbox"/>	Other (please specify) _____

page 5

*** 13. Have you ever used an airbrush in your paintings?** (Select one option)

Yes

Go to Page No. 6

No

Go to Page No. 27

page 6

*** 14. In your opinion, the airbrush is acceptable as an art tool for FINE ART painting?** (Select one option)

Strongly agree

Agree

Not sure

Disagree

Strongly disagree

page 7

*** 15. In general, art historians and critics have not considered airbrush painting to be Fine Art?** (Select one option)

Strongly agree

- Agree
- Not sure
- Disagree
- Strongly disagree

page 8

*** 16. Do you consider airbrushing more laborious than other painting techniques, i.e. needs extra preparation?** (Select one option)

- Strongly agree
- Agree
- Not sure
- Disagree
- Strongly disagree

page 9

*** 17. How often you CURRENTLY use the airbrush for paint application?** (Select one option)

Always

Often

Sometimes

Rarely

Never

*** 18. Please indicate your level of experience with airbrush painting:** (Select one option)

1 year or under

2 - 3 years

4 - 5 years

6 - 7 years

8 - 9 years

10 years or above

page 10

*** 19. In average, how much time do you need to finish an airbrush painting?** (Select one option)

A month or under
 2 - 4 months
 5 - 7 months
 8 - 10 months
 11 months or above

page 11

*** 20. Which brand of airbrushes do you mostly use? (Select one option)**

- Aztek
 Devilbiss
 Iwata
 Paasche
 Revell
 Thayer & Chandler
 Other (please specify) _____

21. Please specify the exact model. (You may leave the text box blank if you

are not sure)

page 12

*** 22. Which type of airbrushes do you use primarily? (Select one option)**

- Single action
- Double action
- Not sure

page 13

*** 23. Which type of airbrush feed systems do you mostly use? (Select one option)**

- Gravity feed airbrush
- Suction feed airbrush
- Side feed airbrush
- Not sure

page 14

*** 24. For airbrushing techniques, do you use any type of stenciling, e.g. firskets?** (Select one option)

- Always
- Often
- Sometimes
- Rarely
- Never

page 15

*** 25. Do you varnish your paintings?** (Select one option)

- Always
- Often
- Sometimes
- Rarely
- Never

page 16

*** 26. Do you use spray paint cans in your paintings?** (Select one option)

- Always
- Often
- Sometimes
- Rarely
- Never

page 17

*** 27. Do you use a spray gun (e.g. for backgrounds)?** (Select one option)

- Always
- Often
- Sometimes
- Rarely
- Never

page 18

28. Which model(s) of airbrush compressors do you use?

<hr/> <hr/> <hr/>

page 19

*** 29. Which type(s) of support do you use for airbrush painting? (Select all that apply)**

- Canvas (natural fabric, e.g. cotton)
- Canvas (synthetic fabric, e.g. polyester)
- Leather (e.g. parchment)
- Metal sheets (e.g. aluminium)
- Paper (e.g. cardboard)
- Wooden panels (e.g. plywood, masonite, etc.)
- Other (please specify) _____

*** 30. How often do you use CANVAS as a support for your airbrush painting? (Select one option)**

- Always
- Often

Sometimes

Rarely

Never

page 20

*** 31. Choose one of the following sentences that applies to you:** (Select one option)

I prefer to obtain readily stretched and primed canvas

I prefer to obtain readily stretched canvas but I prime it myself

I prefer to stretch and prime canvas myself

I prefer to paint on unprimed canvas

Not applicable

Other (please elaborate) _____

*** 32. When you prime (gesso) your canvas yourself, how many layers do you often apply?** (Select one option)

Non (I prefer unprimed canvas)

- 1 - 2
- 3 - 5
- 6 - 8
- 9 or More
- Not applicable

*** 33. How often you prefer sanding the canvas surface, i.e. to make it smooth, before airbrushing?** (Select one option)

- Always
- Often
- Sometimes
- Rarely
- Never
- Not applicable

page 21

*** 34. Along with the airbrush, how often do you use other tools for paint application, e.g. paintbrushes, palette knives, etc.?** (Select one option)

- Always
- Often
- Sometimes
- Rarely
- Never, I solely use the airbrush.

page 22

*** 35. After finishing your airbrush paintings: did you later notice any type of damage in the paint surface, e.g. cracks? (Select one option)**

- Always
- Often
- Sometimes
- Rarely
- Never

page 23

*** 36. What type of type(s) of damage did you notice? (Select all that apply) [Answer this question only if answer to Q#35 is NOT (Never)]**

<input type="checkbox"/>	Cracks in the paint surface
<input type="checkbox"/>	Discolouration in the paint surface
<input type="checkbox"/>	Loss in sections in the paint surface
<input type="checkbox"/>	Other (please specify) _____

page 24

*** 37. Do you use acrylic paint for airbrushing? (Select one option)**

- Always
- Often
- Sometimes
- Rarely
- Never

*** 38. Which brand do you usually use for ACRYLIC paints? (Select all that apply)**

- Not applicable
- Daler-Rowney

<input type="checkbox"/>	Golden
<input type="checkbox"/>	Liquitex
<input type="checkbox"/>	Reeves
<input type="checkbox"/>	Royal & Langnickel
<input type="checkbox"/>	Winsor & Newton
<input type="checkbox"/>	Other (please specify) _____

page 25

*** 39. Do you have your own art studio?** (Select one option)

- Yes
- No (if you select NO please ignore other questions in this page and go to the next page)

40. What is the size of your studio in approximate? (m² = square metres, ft² = square feet) (Select one option)

- Less than 50m² (less than 538ft²)
- 50m² - less than 100m² (538ft² - less than 1076.4ft²)
- 100m² - less than 150m² (1076ft² - less than 1614ft²)

150m² - less than 200m² (1614ft² - less than 2152ft²)

200m² or above (2152ft²)

41. Do you equip your studio with ventilation system? (Select one option)

Yes

No

page 26

*** 42. Do you use health and safety equipment when use the airbrush, e.g. protective masks? (Select one option)**

Always

Very Often

Sometimes

Almost Never

Never

page 27

*** 43. In your opinion, the airbrush is acceptable as an art tool for FINE ART painting?** (Select one option) [Answer this question only if answer to Q#13 is NOT (Yes)]

- Strongly agree
- Agree
- Not sure
- Disagree
- Strongly disagree

page 28

*** 44. In general, art historians and critics have not considered airbrush painting to be Fine Art?** (Select one option) [Answer this question only if answer to Q#13 is NOT (Yes)]

- Strongly agree
- Agree
- Not sure
- Disagree
- Strongly disagree

page 29

*** 45. Do you consider airbrushing more laborious than other painting techniques, i.e. needs extra preparation?** (Select one option) [Answer this question only if answer to Q#13 is NOT (Yes)]

- Strongly agree
- Agree
- Not sure
- Disagree
- Strongly disagree

page 30

*** 46. You do not think about using the airbrush because: (Select all that apply)**

[Answer this question only if answer to Q#13 is NOT (Yes)]

- Airbrushing equipment is relatively expensive.
- Because of health hazards that can be expected from airbrushing.
- I do not have enough space to use the equipment.
- I do not think the airbrush can be considered a proper tool for fine art.
- It will be difficult to start learning airbrushing techniques.

It will be cumbersome to do regular maintenance to the airbrush equipment.

It will be difficult to sell an airbrush painting.

Other (please elaborate) _____

page 31

47. It will be very helpful for the researcher if you had any comments or thoughts you kindly would like to share. Please feel free to elaborate here on any of the responses you have given, or add any comment you think it can benefit the research:

page 32

*** 48. Do you wish to receive the final results of this survey? (Select one option)**

Yes

No

*** 49. Can the researcher contact you for further queries or information? (Select one option)**

Yes

No

If the answer was yes to one or both of the last two questions please provide your contact details below:

50. Your contact details:

(a) Title

(b) Name

(c) Address 1

(d) Address 2

(e) City/Town

(f) State/Province

(g) Zip/Postal Code

(h) Country (Select one option)

Afghanistan

- Albania
- Algeria
- Andorra
- Angola
- Antigua and Barbuda
- Argentina
- Armenia
- Australia
- Austria
- Azerbaijan
- Bahamas
- Bahrain
- Bangladesh
- Barbados
- Belarus
- Belgium
- Belize
- Benin
- Bhutan
- Bolivia
- Bosnia
- Botswana

- Brazil
- Brunei
- Bulgaria
- Burkina Faso
- Burma
- Burundi
- Cambodia
- Cameroon
- Canada
- Cape Verde
- Central African Republic
- Chad
- Chile
- China
- Colombia
- Comoros
- Congo (Brazzaville)
- Congo (Kinshasa)
- Costa Rica
- Cote d'Ivoire
- Croatia
- Cuba

- Cyprus
- Czech Republic
- Denmark
- Djibouti
- Dominica
- Dominican Republic
- East Timor Timor Timur
- Ecuador
- Egypt
- El Salvador
- Equatorial Guinea
- Eritrea
- Estonia
- Ethiopia
- Fiji
- Finland
- France
- Gabon
- Gambia
- Georgia
- Germany
- Ghana

- Greece
- Grenada
- Guatemala
- Guinea
- Guinea-Bissau
- Guyana
- Haiti
- Holy See
- Honduras
- Hong Kong
- Hungary
- Iceland
- India
- Indonesia
- Iran
- Iraq
- Ireland
- Israel
- Italy
- Jamaica
- Japan
- Jordan

- Kazakhstan
- Kenya
- Kiribati
- Kosovo
- Kuwait
- Kyrgyzstan
- Laos
- Latvia
- Lebanon
- Lesotho
- Liberia
- Libya
- Liechtenstein
- Lithuania
- Luxembourg
- Macau
- Macedonia
- Madagascar
- Malawi
- Malaysia
- Maldives
- Mali

- Malta
- Marshall Islands
- Mauritania
- Mauritius
- Mexico
- Micronesia
- Moldova
- Monaco
- Mongolia
- Montenegro
- Morocco
- Mozambique
- Namibia
- Nauru
- Nepal
- Netherlands
- Netherlands Antilles
- New Zealand
- Nicaragua
- Niger
- Nigeria
- North Korea

- Norway
- Oman
- Pakistan
- Palau
- Palestinian Territories
- Panama
- Papua New Guinea
- Paraguay
- Peru
- Philippines
- Poland
- Portugal
- Puerto Rico
- Qatar
- Romania
- Russia
- Rwanda
- Saint Kitts and Nevis
- Saint Lucia
- Saint Vincent and the Grenadines
- Samoa
- San Marino

- Sao Tome and Principe
- Saudi Arabia
- Senegal
- Serbia
- Seychelles
- Sierra Leone
- Singapore
- Slovakia
- Slovenia
- Solomon Islands
- Somalia
- South Africa
- South Korea
- Spain
- Sri Lanka
- Sudan
- Suriname
- Swaziland
- Sweden
- Switzerland
- Syria
- Taiwan

- Tajikistan
- Tanzania
- Thailand
- Timor-Leste
- Togo
- Tonga
- Trinidad and Tobago
- Tunisia
- Turkey
- Turkmenistan
- Tuvalu
- Uganda
- Ukraine
- United Arab Emirates
- United Kingdom
- United States of America
- Uruguay
- Uzbekistan
- Vanuatu
- Venezuela
- Vietnam
- Yemen

	<input type="radio"/> Zambia <input type="radio"/> Zimbabwe
(i)	Telephone
	<hr/> <hr/>
(j)	Mobile no.
	<hr/> <hr/>
(k)	Email Address
	<hr/> <hr/>

A.1.4 Verbatim responses to the questionnaire aimed at fine artists

Q47. It will be very helpful for the researcher if you had any comments or thoughts you kindly would like to share. Please feel free to elaborate here on any of the responses you have given, or add any comment you think it can benefit the research:

Sr.No.	Response No.	Response Text
1	1	<p>I think the tool is not very important regarding the art dealer and collectors. The quality, the emotion, the theme and the subject are most important. Even if they know it is paint with an airbrush, they can't imagine how it is made. That is the reason I often take pictures of my work in order to make a making-off movie. But sometimes they even can't understand. They feel it is magical. Some people don't know what is an airbrush! Sometimes they ask me if it is paint digitally! You have a lot of work to explain this technique. I think airbrush is a tool well known by popular culture because the decoration and custom movement. But in fine art it is less known or disguise in a very good brush technique. I know some photorealism painters who hide the fact they paint with airbrush because it difficult to explain and to justify. I can understand this behaviour. I come from the illustration field and I am proud to master this</p>

		now traditional technique. It is not digital, it is not photography, it is airbrush, it is magical.
2	2	I'm one of only a few artists i know who sprays oil paint through an airbrush / spraygun
3	4	I use airbrush for commercial illustration for 20 years. During that period I used frisket, and illustration board. In 2000 I quit advertising to go fine art. From 2000 until 2004 I us airbrush on canvas with 3-4 coat of gesso to get smooth surface. I also stop using frisket to work freehand (Don Eddy's technique). Paint was so tin that I have a few painting that lost colour due to sun exposure. In late 2004 I switched to oil painting. Most of the galleries that I visited did not look at airbrush as a real fine art technique. a lot of the galleries thought my paintings were printed because they could not see paint brush marks.
4	5	It would be nice to have a system that would keep the paint shaken, preventing deposit in the airbrush bottles. Also, erasing techniques are widely used and different types of erasers are getting hard to find, notably the typewriter erasers (since typewriters are no longer in use).
5	6	Although I use an airbrush almost exclusively in my work, and have for 45 years, I still don't think of myself as an "airbrush" artist.....it is just a tool that works well for me. I have taught upper level airbrush classes in Las Vegas and Orlando for an Airbrush magazine, and I can honestly admit that I have almost nothing in common with that group of people. While I feel it's true that airbrushes may be frowned upon by critics, etc., in general that may be due to the fact that no one really makes very good paintings with one.....Chuck Close, Audrey Flack (horrible airbrusher) and Don Eddy were quite successful and accepted. Most airbrush painters are quite bad.....I've met and been aware of very few that actually produced good paintings.
6	7	Currently I use a home studio to keep costs low hence the small size and lack of ventilation system. I may look into getting an extractor fan set up when I have the funds.
7	9	If you happen to be in Orlando, Carlifornia may 15-19, I am replacing Dru Blair at the Getaway workshop. There I will teach airbrushing on canvas among other things. There will also be a step-by-step-article with one of my pieces airbrushed on canvas in the 04/2013 issue of the German

		magazine Airbrush Step by Step which will be in stores at the beginning of September. Regards and good luck with your research.
--	--	---

A.2 Appendix B: Accelerated Light Ageing Test Tables and Graphs

A.2.1 Accelerated Light Ageing Test no. 1

Accelerated Light Ageing Test no. 1: Cyan Samples

Table 23: comparison between the changes in colour values (Δ) of airbrushed and paint-brushed primary cyan samples

Change in values (Δ)	Artificially aged airbrushed primary cyan sample	Artificially aged paint-brushed primary cyan sample
ΔL^*	-1.63	0.63
Δa^*	0.48	-0.87
Δb^*	2.00	0.41
ΔC^*	-2.02	-0.34
ΔH^*	-0.42	-0.90
ΔE^*_{ab}	2.63	1.15

Table 24: further detailed data of the numerical colour values of the non-aged compared to artificially light aged paint layers of both airbrushed and paint-brushed Cyan samples.

Colour Value	Airbrushed primary Cyan samples		Paint-brushed primary Cyan samples	
	Non-aged	Aged	Non-aged	Aged
L^*	49.07	47.44	33.40	34.03
a^*	-21.71	-21.23	-2.38	-3.25
b^*	-46.59	-44.59	-40.30	-39.90
C^*	51.40	49.38	40.37	40.03
H	245.01	244.54	266.62	265.34

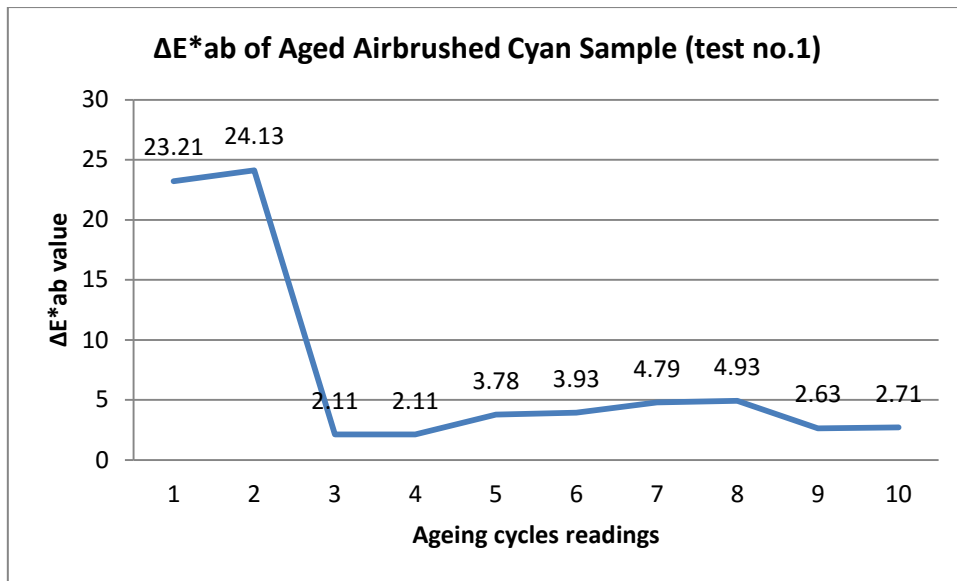

Figure 123: linear chart represents a timeline of changes in colour value (ΔE^*ab) according to the readings of the accelerated light-ageing cycles for the airbrushed primary cyan sample

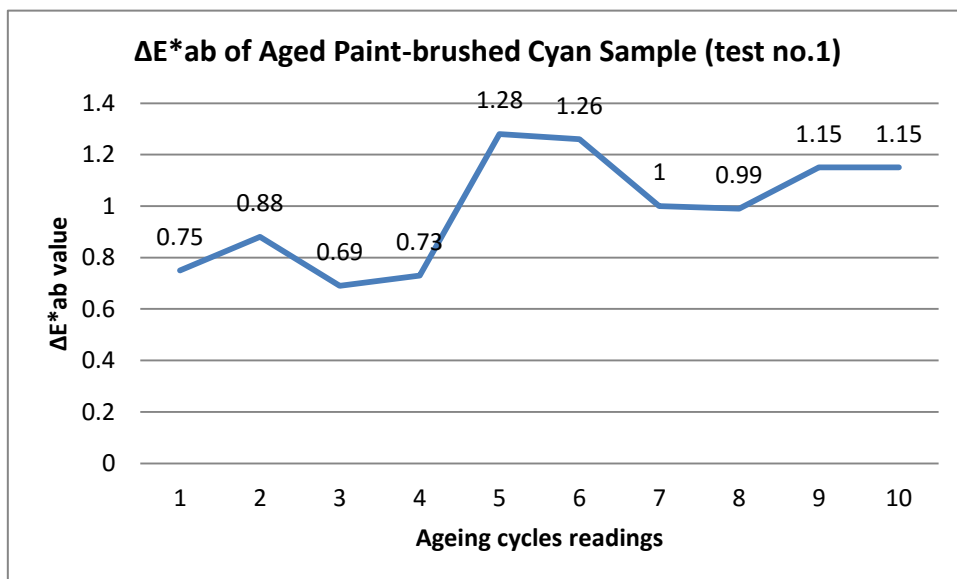

Figure 124: linear chart represents a timeline of changes in colour value (ΔE^*ab) according to the readings of the accelerated light-ageing cycles for the paint-brushed primary cyan sample

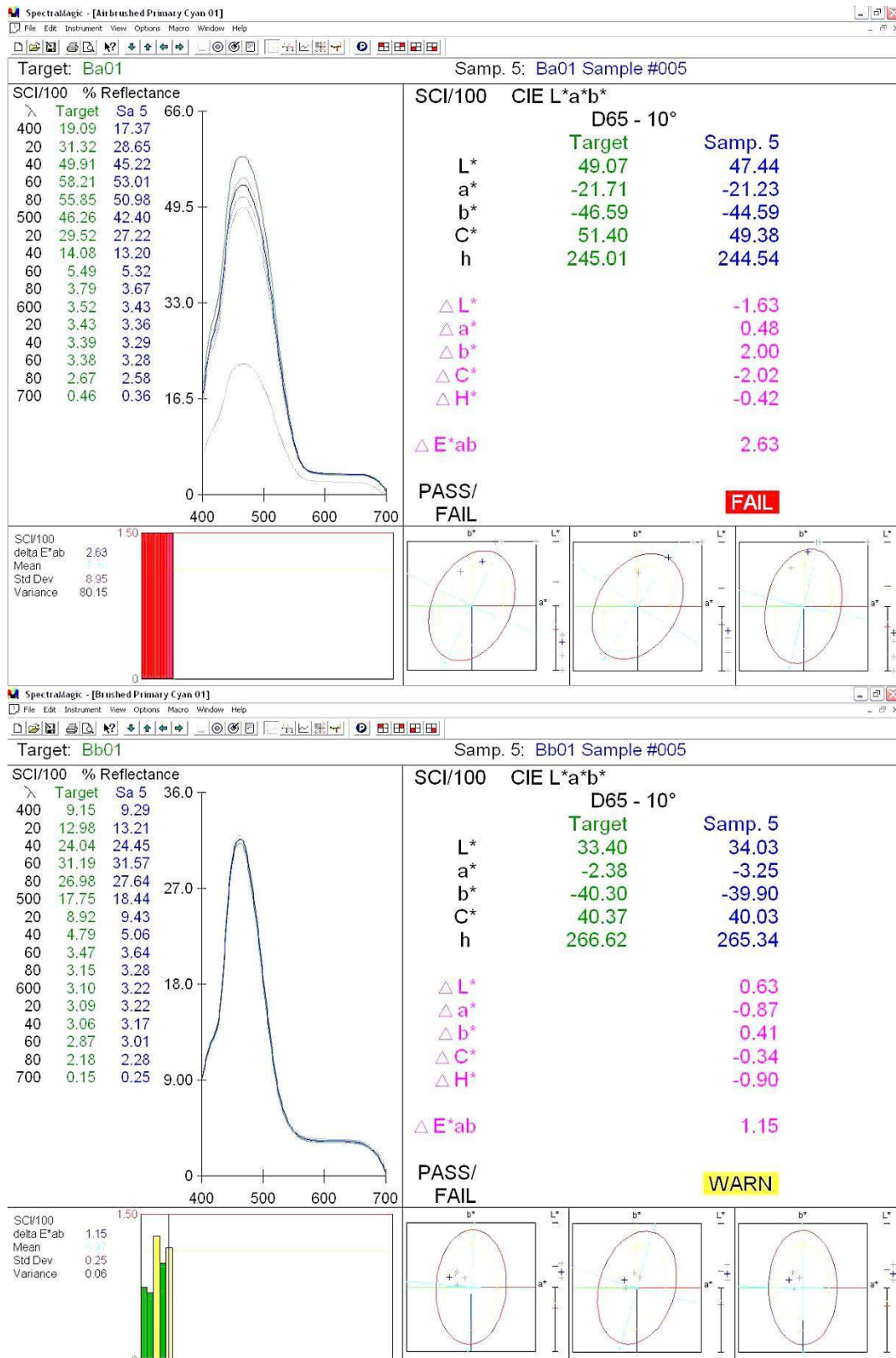

Figure 125: a comparison between a spectrophotometric graph of an artificially aged airbrushed primary cyan sample (above) and a spectrophotometric graph of an artificially aged paint-brushed primary cyan sample (below)

Accelerated Light Ageing Test no. 1: Magenta Samples

Table 25: a comparison between the changes in the values (Δ) of airbrushed and paint-brushed primary magenta samples

Change in values (Δ)	Artificially aged airbrushed primary magenta sample	Artificially aged paint-brushed primary magenta sample
ΔL^*	-2.02	-0.58
Δa^*	3.76	-3.06
Δb^*	-0.54	-1.78
ΔC^*	-3.79	-3.54
ΔH^*	-0.15	-0.14
ΔE^*_{ab}	4.30	3.59

Table 26: further detailed data of the numerical colour values of the non-aged compared to artificially light aged paint layers of both airbrushed and paint-brushed Magenta samples.

Colour Value	Airbrushed primary Magenta samples		Paint-brushed primary Magenta samples	
	Non-aged	aged	Non-aged	Aged
L^*	54.38	52.36	41.28	40.70
a^*	62.47	58.72	55.11	52.05
b^*	6.44	5.91	29.31	27.53
C^*	62.80	59.01	41.28	40.70
h	5.89	5.75	55.11	52.05

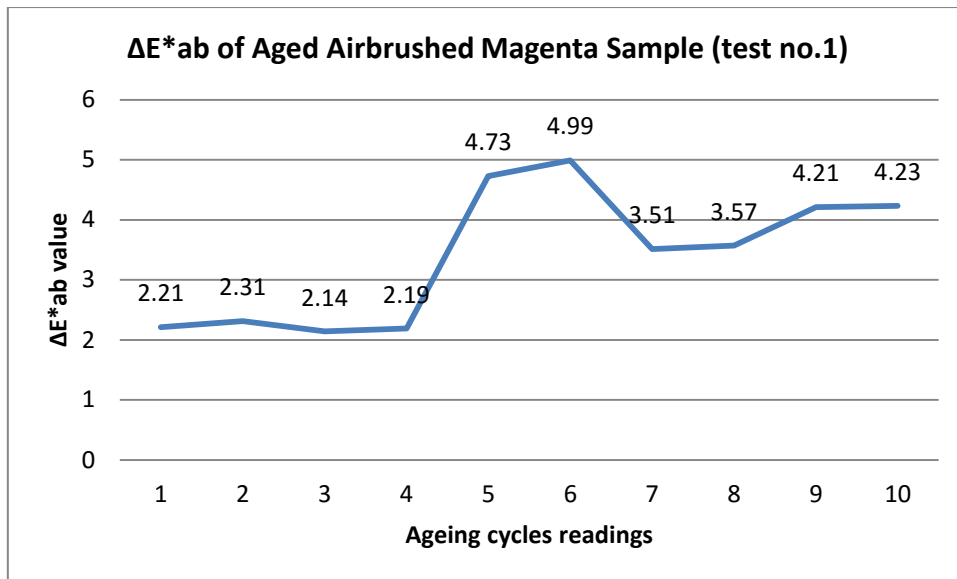

Figure 126: linear chart represents a timeline of changes in colour value (ΔE^*ab) according to the readings of the accelerated light-ageing cycles for the airbrushed Primary Magenta sample

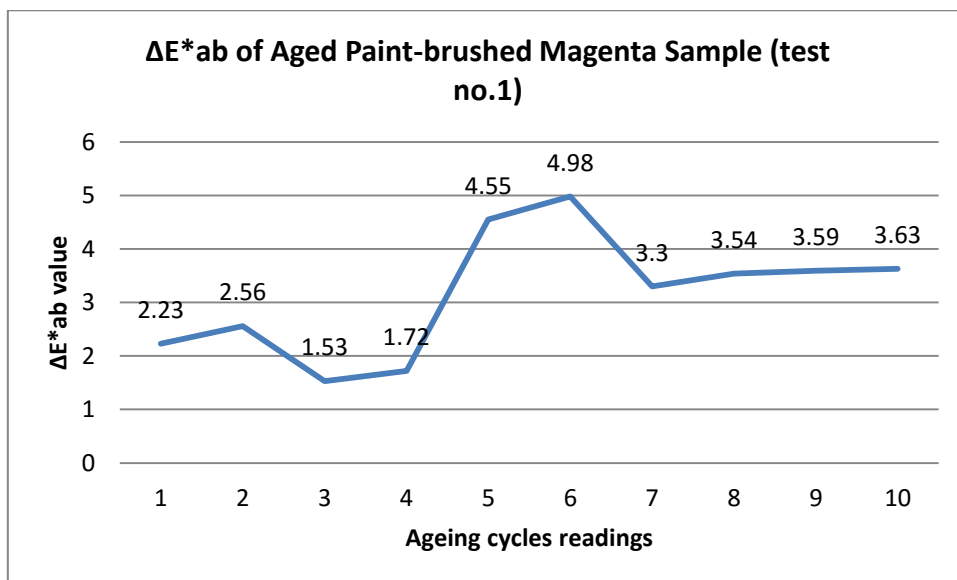

Figure 127: linear chart represents a timeline of changes in colour value (ΔE^*ab) according to the readings of the accelerated light-ageing cycles for the paint-brushed Primary Magenta sample

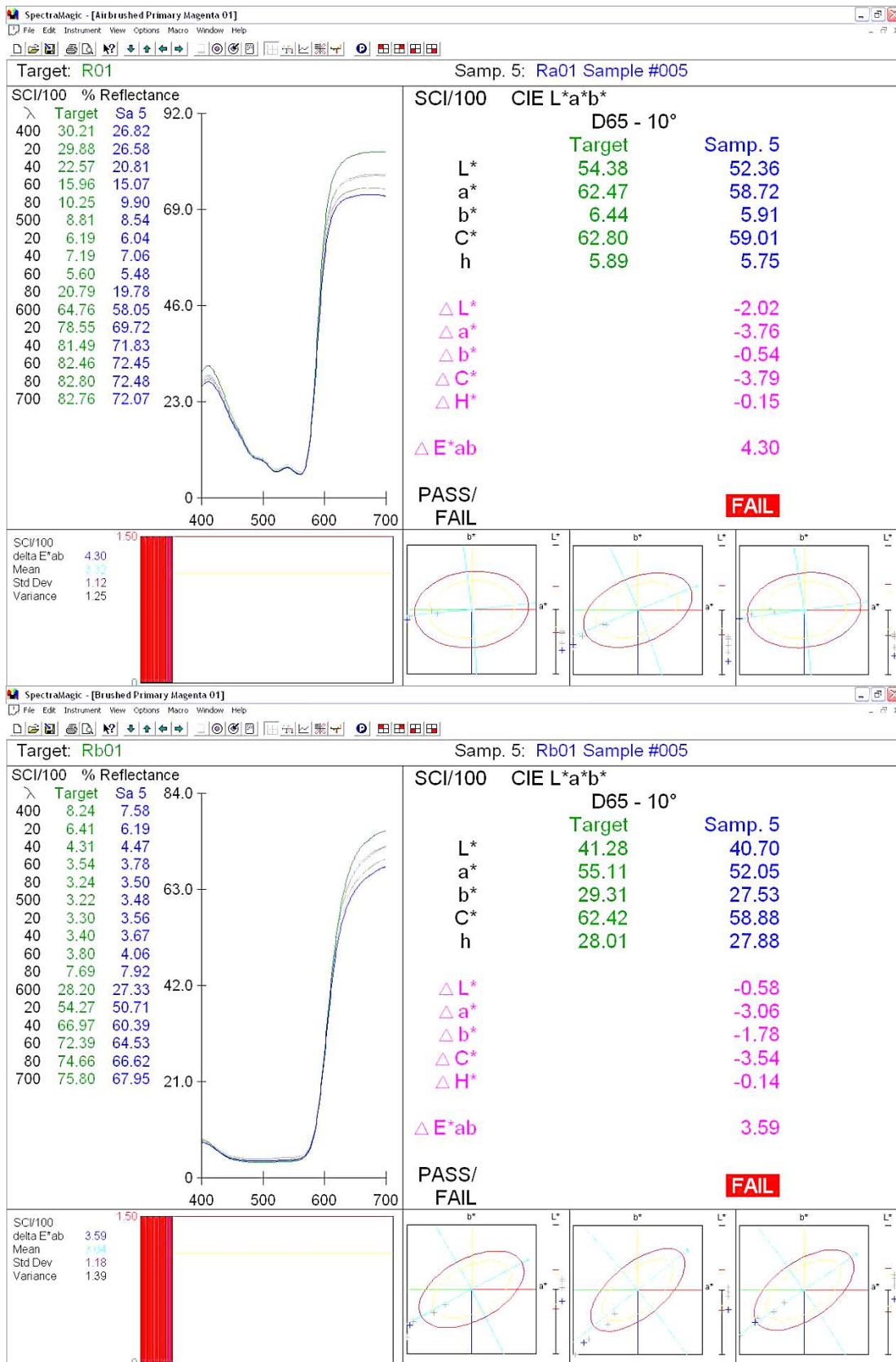

Figure 128: a comparison between a spectrophotometric graph of an artificially aged airbrushed primary magenta sample (above) and a spectrophotometric graph of an artificially aged paint-brushed primary magenta sample (below)

Accelerated Light Ageing Test no. 1: Yellow Samples

Table 27: a comparison between the changes in the values (Δ) of airbrushed and paint-brushed primary yellow samples

Change in values (Δ)	Artificially aged airbrushed primary yellow sample	Artificially aged paint-brushed primary yellow sample
ΔL^*	-2.71	1.47
Δa^*	-0.47	0.65
Δb^*	-7.47	-3.94
ΔC^*	-7.43	-3.93
ΔH^*	-0.88	-0.70
ΔE^*_{ab}	7.96	4.25

Table 28: further detailed data of the numerical colour values of the non-aged compared to artificially light aged paint layers of both airbrushed and paint-brushed Yellow samples.

Colour Value	Airbrushed primary Yellow samples		Paint-brushed primary Yellow samples	
	Non-aged	Aged	Non-aged	Aged
L^*	89.10	86.38	87.60	86.13
a^*	-4.93	-5.40	0.94	1.59
b^*	97.83	90.36	101.36	97.43
C^*	97.96	90.53	101.37	97.44
h	92.89	93.42	89.47	89.06

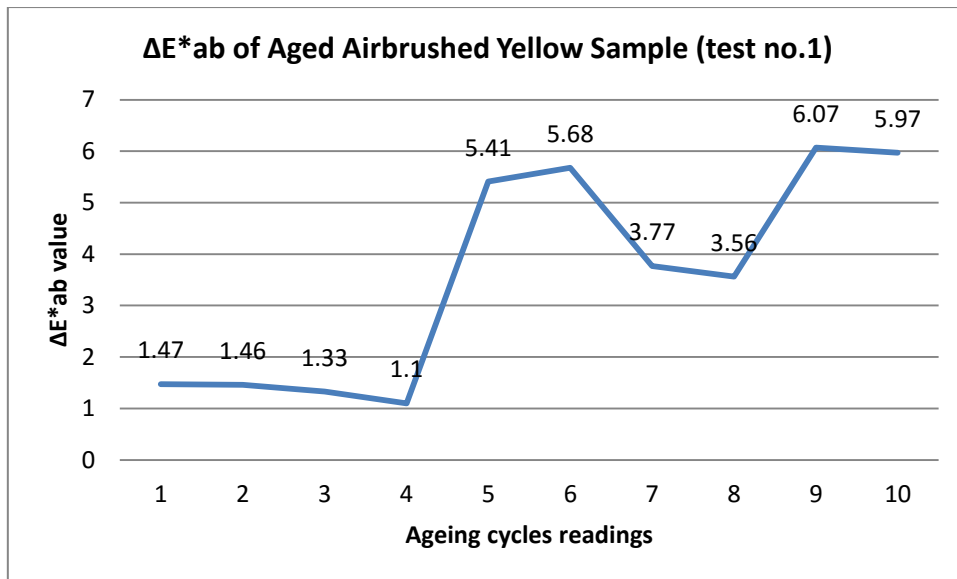

Figure 129: linear chart represents a timeline of changes in colour value (ΔE^*ab) according to the readings of the accelerated light-ageing cycles for the airbrushed Primary Yellow sample

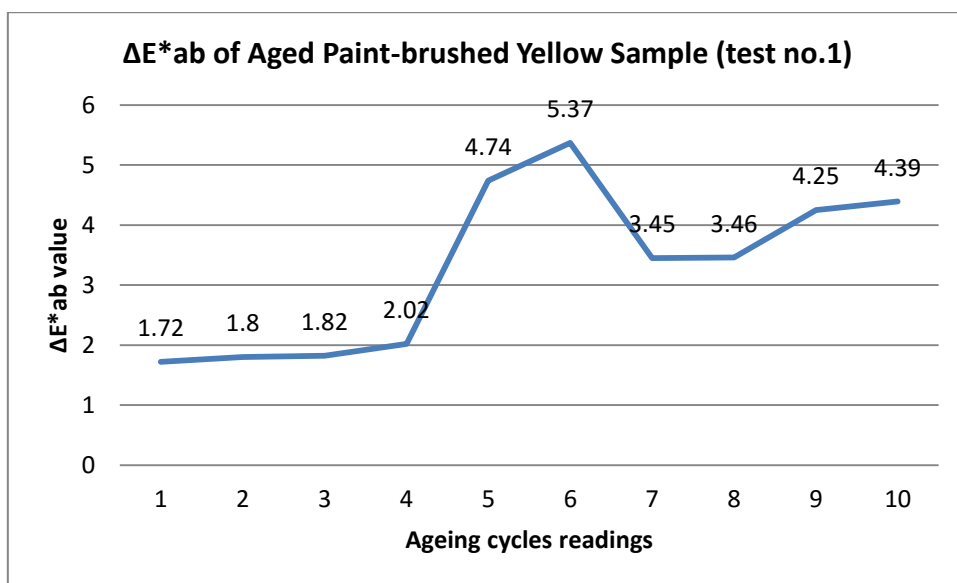

Figure 130: linear chart represents a timeline of changes in colour value (ΔE^*ab) according to the readings of the accelerated light-ageing cycles for the paint-brushed Primary Yellow sample

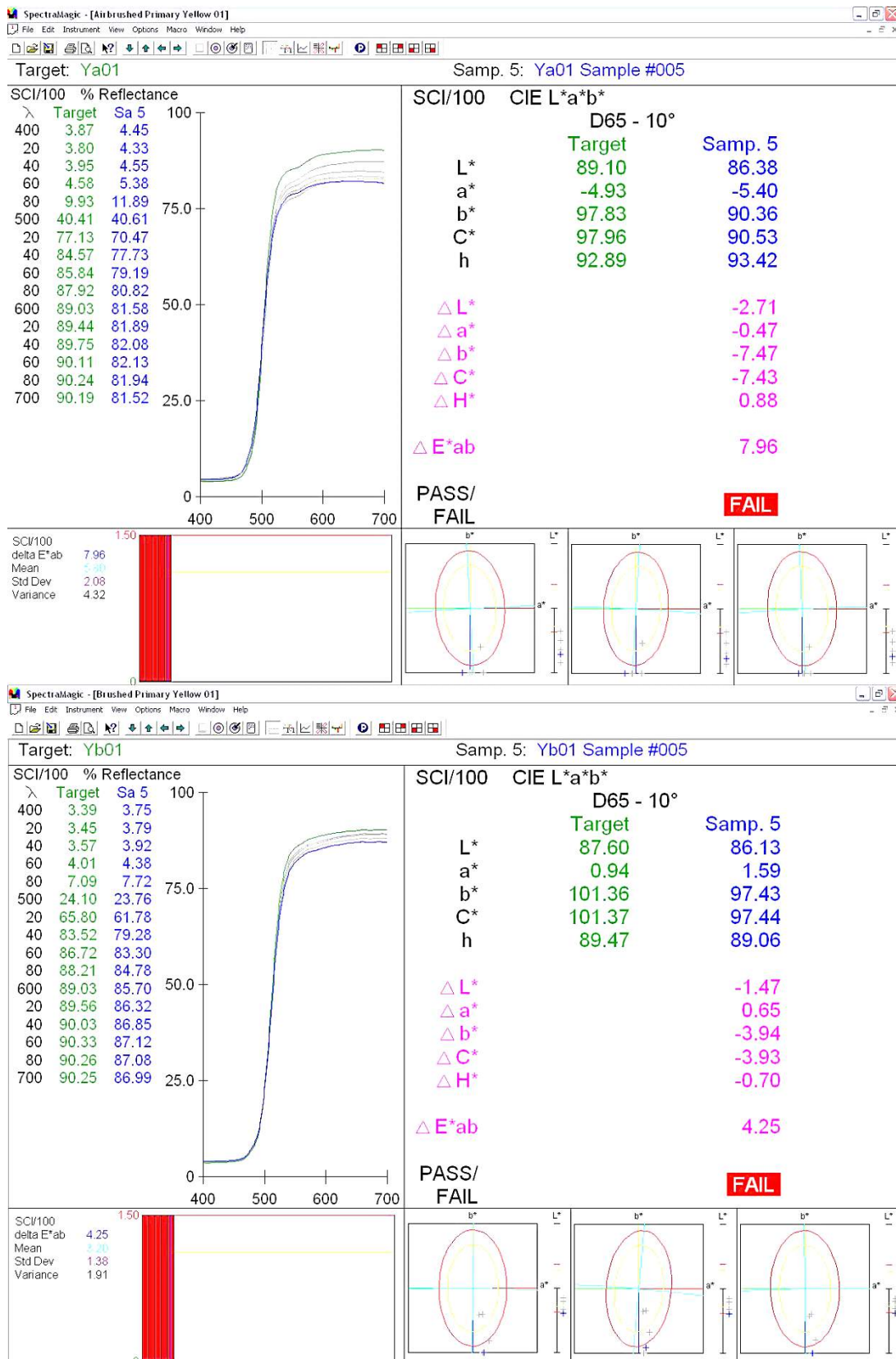

Figure 131: a comparison between a spectrophotometric graph of an artificially aged airbrushed primary yellow sample (above) and a spectrophotometric graph of an artificially aged paint-brushed primary yellow sample (below)

A.2.2 Accelerated Light Ageing Test no. 2

Accelerated Light Ageing Test no. 2: Cyan Samples

Table 29: comparison between the changes in the values (Δ) of airbrushed and paint-brushed primary cyan samples (accelerated light ageing test no.2)

Change in values (Δ)	Artificially aged airbrushed primary cyan sample	Artificially aged paint-brushed primary cyan sample
ΔL^*	0.30	-0.02
Δa^*	-0.27	-0.37
Δb^*	0.31	0.60
ΔC^*	-0.30	-0.59
ΔH^*	-0.27	-0.39
ΔE^*_{ab}	0.50	0.71

Table 30: further detailed data of the numerical colour values of the non-aged compared to artificially light aged paint layers of both airbrushed and paint-brushed Cyan samples (accelerated light ageing test no.2)

Colour Value	Airbrushed primary Cyan samples (ageing test 2)		Paint-brushed primary Cyan samples (ageing test 2)	
	Non-aged	aged	Non-aged	Aged
L^*	30.36	30.65	30.32	30.30
a^*	-0.82	-1.09	-1.17	-1.54
b^*	-38.86	-38.55	-37.60	-37.00
C^*	38.87	38.56	37.62	37.03
h	268.79	268.39	268.22	267.61

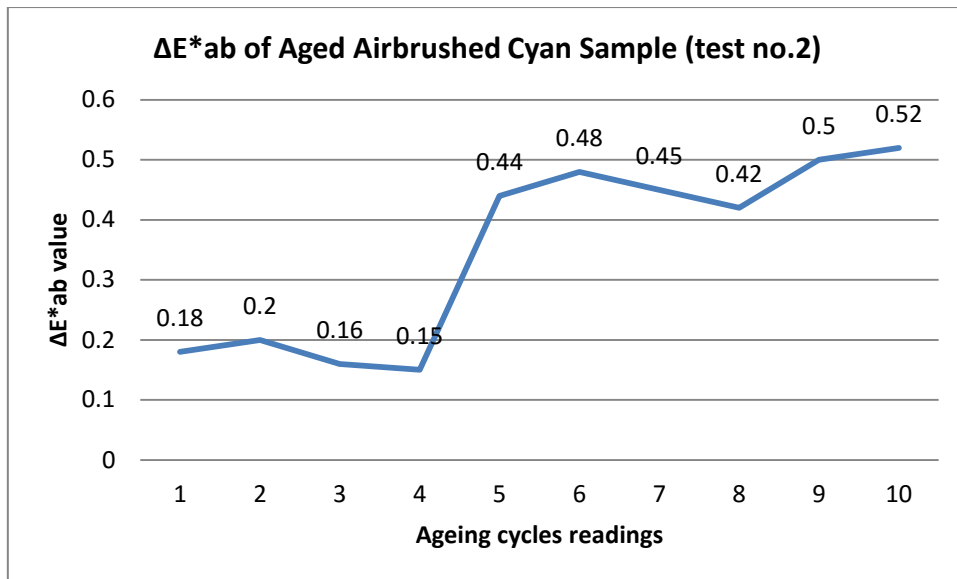

Figure 132: linear chart represents a timeline of changes in colour value (ΔE^*ab) according to the readings of second the accelerated light-ageing cycles for the airbrushed Primary Cyan sample

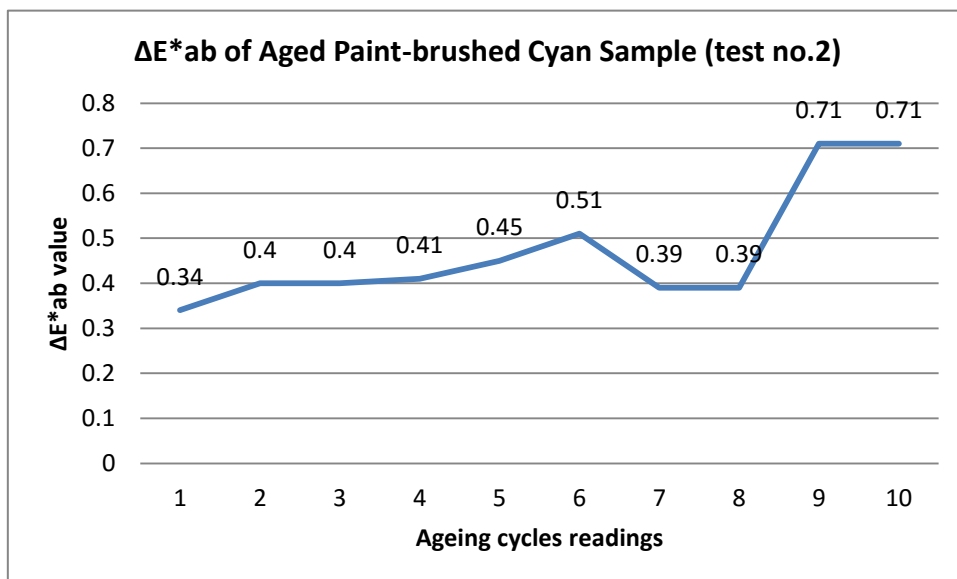
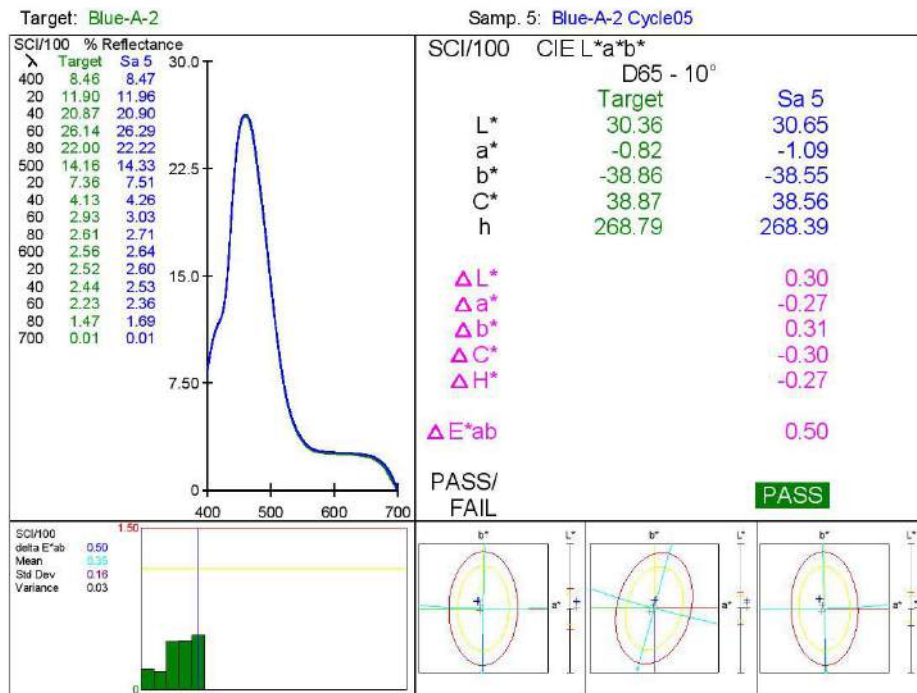

Figure 133: linear chart represents a timeline of changes in colour value (ΔE^*ab) according to the readings of second the accelerated light-ageing cycles for the paint-brushed Primary Cyan sample

Minolta Co., Ltd.
Osaka, Japan

Printed: 01/12/2014
Measured On: CM-2600d CRBIMM

FILENAME: Blue-A-2 Cycle05



Minolta Co., Ltd.
Osaka, Japan

Printed: 01/12/2014
Measured On: CM-2600d CRBIMM

FILENAME: Blue-B-2 Cycle05

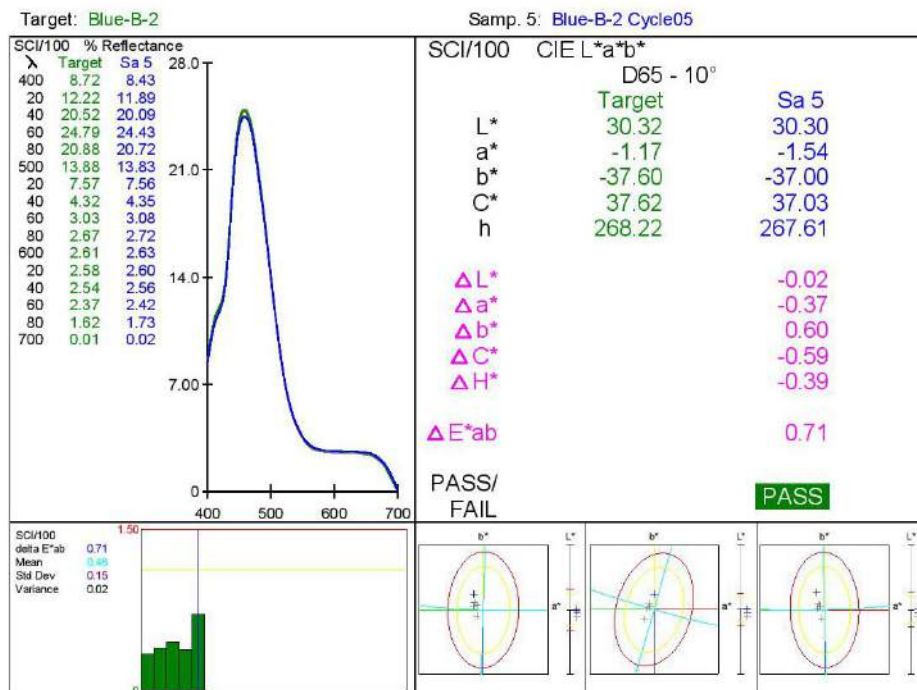

Figure 134: comparison between a spectrophotometric graph of an artificially aged airbrushed primary cyan sample (above) and a spectrophotometric graph of an artificially aged paint-brushed primary cyan sample (below) - (accelerated ageing test no.2)

Accelerated Light Ageing Test no. 2: Magenta Samples

Table 31: comparison between the changes in the values (Δ) of airbrushed and paint-brushed primary magenta samples (accelerated light ageing test no.2)

Change in values (Δ)	Artificially aged airbrushed primary magenta sample	Artificially aged paint-brushed primary magenta sample
ΔL^*	-0.21	-0.55
Δa^*	-0.86	-0.67
Δb^*	0.15	0.56
ΔC^*	-0.68	-0.31
ΔH^*	0.55	-0.82
ΔE^*_{ab}	0.90	1.03

Table 32: further detailed data of the numerical colour values of the non-aged compared to artificially light aged paint layers of both airbrushed and paint-brushed Magenta samples (accelerated light ageing test no.2)

Colour Value	Airbrushed primary Magenta samples (ageing test 2)		Paint-brushed primary Magenta samples (ageing test 2)	
	Non-aged	aged	Non-aged	aged
L^*	37.62	37.41	36.21	35.66
a^*	51.97	51.11	50.29	49.62
b^*	28.54	28.69	27.74	28.30
C^*	59.29	58.61	57.43	57.13
h	28.77	29.31	28.88	29.70

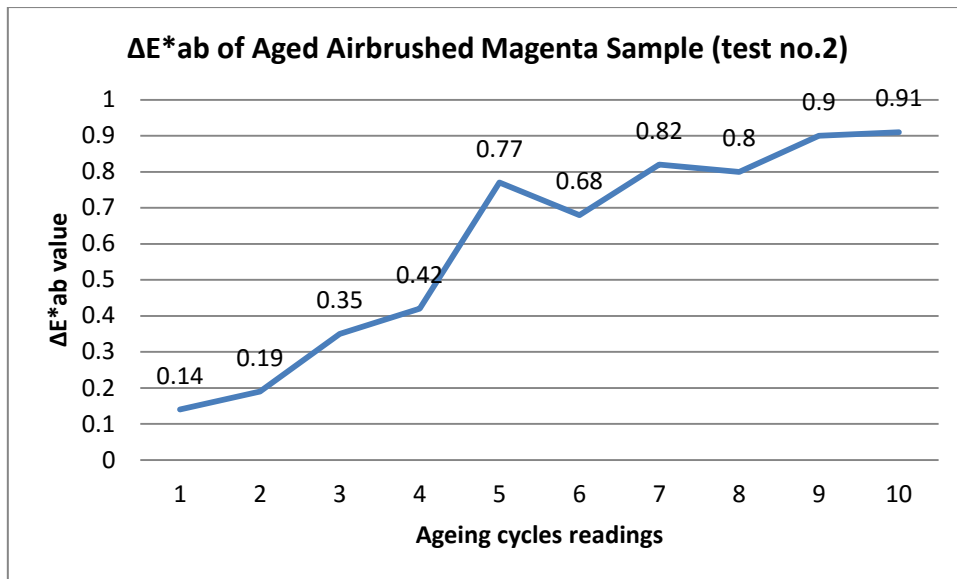

Figure 135: linear chart represents a timeline of changes in colour value (ΔE^*ab) according to the readings of second the accelerated light-ageing cycles for the airbrushed Primary Magenta sample

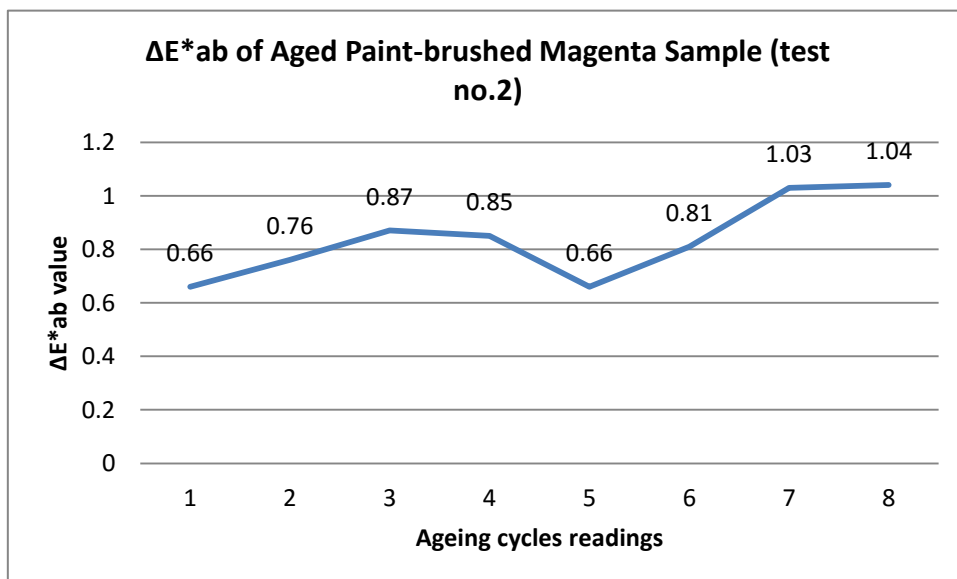
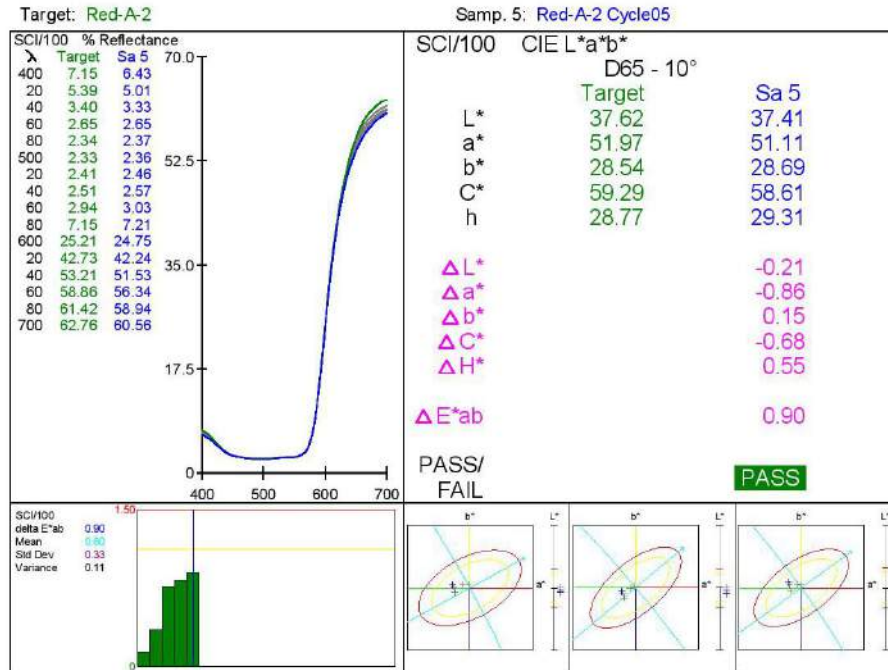

Figure 136: linear chart represents a timeline of changes in colour value (ΔE^*ab) according to the readings of second the accelerated light-ageing cycles for the paint-brushed Primary Magenta sample

Minolta Co., Ltd.
Osaka, Japan

Printed: 01/12/2014
Measured On: CM-2600d CRBIMM

FILENAME: Red-A-2 Cycle05



Minolta Co., Ltd.
Osaka, Japan

Printed: 01/12/2014
Measured On: CM-2600d CRBIMM

FILENAME: Red-B-2 Cycle05

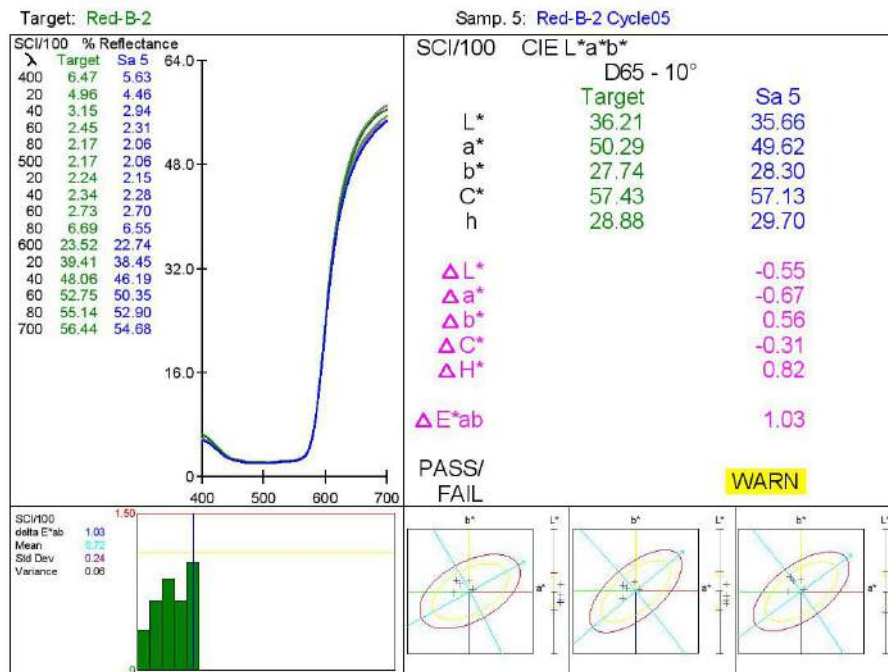

Figure 137: comparison between a spectrophotometric graph of an artificially aged airbrushed primary magenta sample (above) and a spectrophotometric graph of an artificially aged paint-brushed primary magenta sample (below) - (accelerated ageing test no.2)

Accelerated Light Ageing Test no. 2: Yellow Samples

Table 33: comparison between the changes in the values (Δ) of airbrushed and paint-brushed primary yellow samples (accelerated light ageing test no.2)

Change in values (Δ)	Artificially aged airbrushed primary yellow sample	Artificially aged paint-brushed primary yellow sample
ΔL^*	-0.63	-0.46
Δa^*	1.19	1.49
Δb^*	-2.28	-2.39
ΔC^*	-2.24	-2.34
ΔH^*	-1.27	-1.57
ΔE^*_{ab}	2.65	2.86

Table 34: further detailed data of the numerical colour values of the non-aged compared to artificially light aged paint layers of both airbrushed and paint-brushed Yellow samples (accelerated light ageing test no.2)

Colour Value	Airbrushed primary Yellow samples (ageing test 2)		Paint-brushed primary Yellow samples (ageing test 2)	
	Non-aged	aged	Non-aged	aged
L^*	83.28	82.65	84.36	83.90
a^*	2.74	3.93	2.38	3.87
b^*	95.61	93.33	96.15	93.76
C^*	95.65	93.41	96.18	93.84
h	88.36	87.59	88.58	87.64

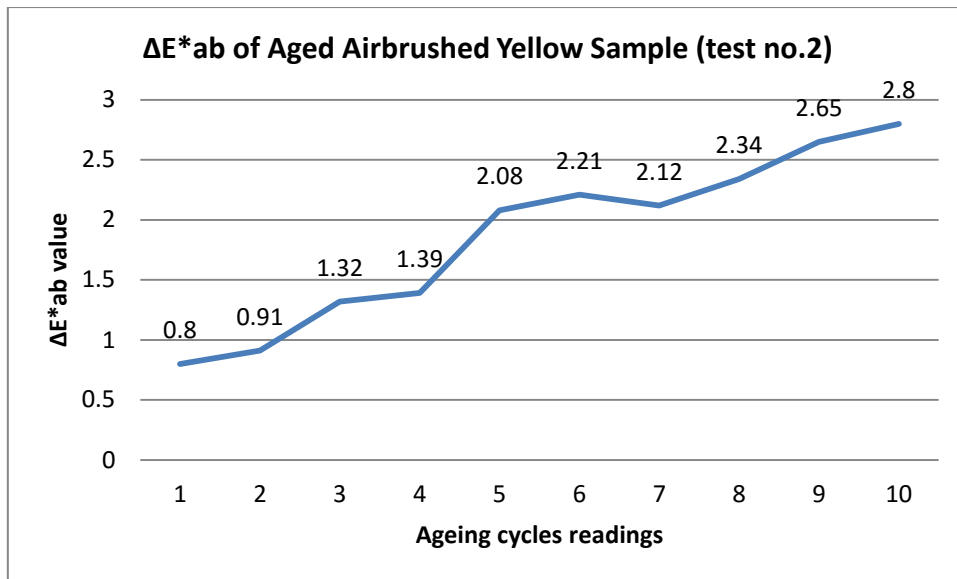

Figure 138: linear chart represents a timeline of changes in colour value (ΔE^*ab) according to the readings of second the accelerated light-ageing cycles for the airbrushed Primary Yellow sample

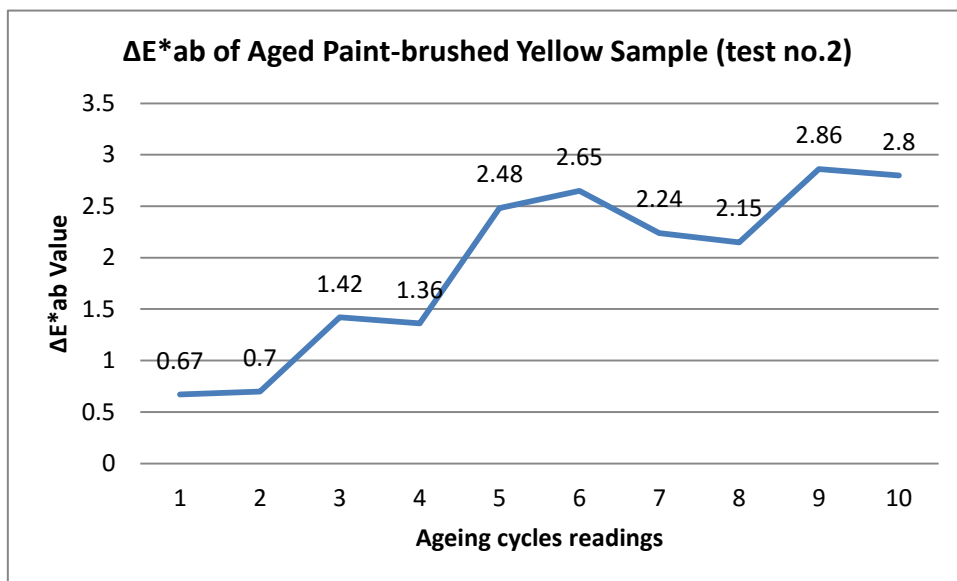
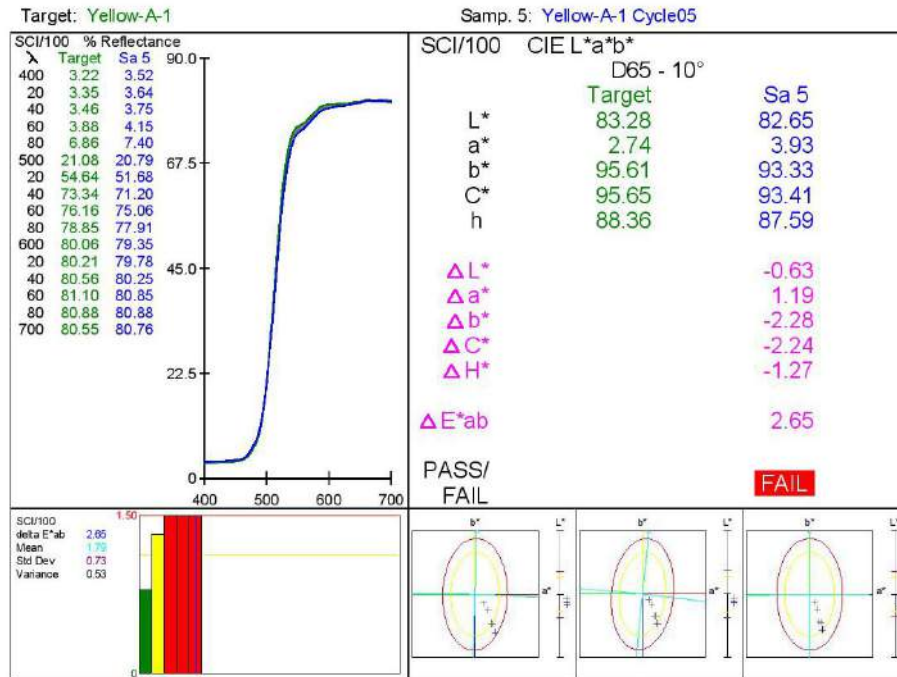

Figure 139: linear chart represents a timeline of changes in colour value (ΔE^*ab) according to the readings of second the accelerated light-ageing cycles for the paint-brushed Primary Yellow sample

Minolta Co., Ltd.
Osaka, Japan

Printed: 01/12/2014
Measured On: CM-2600d CRBIMM

FILENAME: Yellow-A-1 Cycle05



Minolta Co., Ltd.
Osaka, Japan

Printed: 01/12/2014
Measured On: CM-2600d CRBIMM

FILENAME: Yellow-B-1 Cycle05

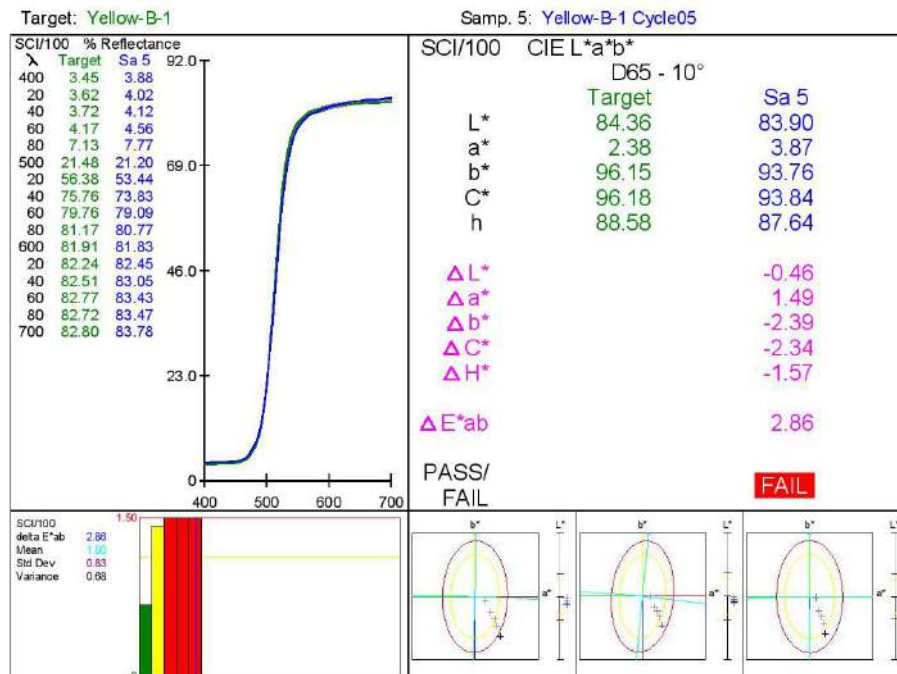
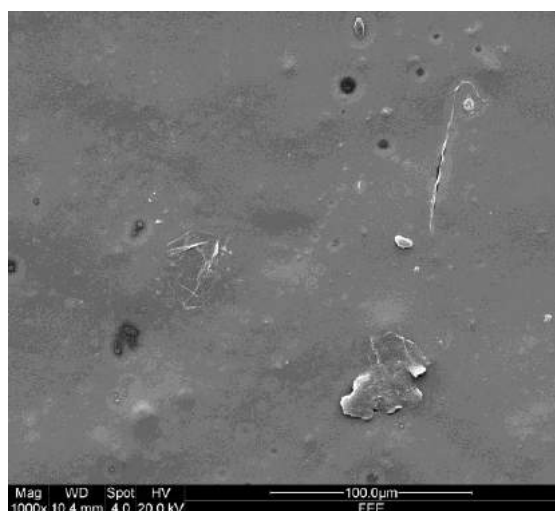

Figure 140: comparison between a spectrophotometric graph of an artificially aged airbrushed primary yellow sample (above) and a spectrophotometric graph of an artificially aged paint-brushed primary yellow sample (below) - (accelerated ageing test no.2)

A.3 Appendix C: SEM images (all images listed are magnified at 1000x)

A.3.1 SEM Imaging (Samples Group 1): a. Airbrushed Aged vs. paint-brushed aged



Airbrushed Aged Cyan

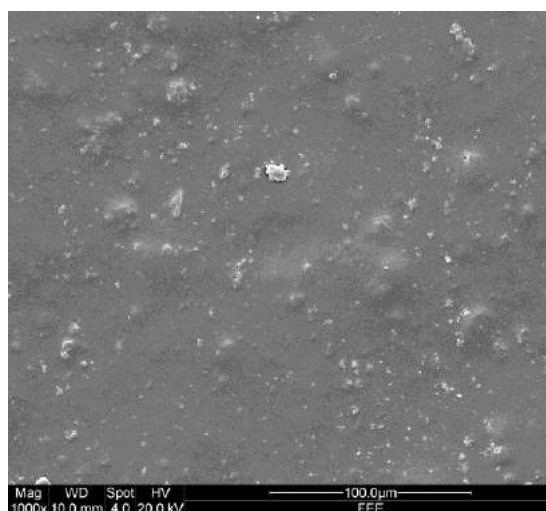

Paint-brushed Aged Cyan

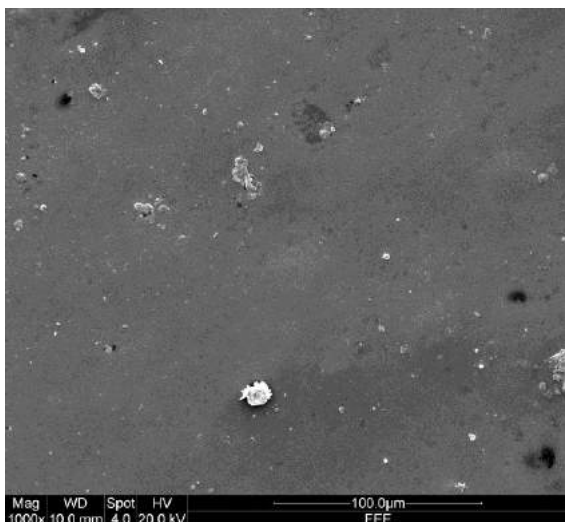

Airbrushed Aged Red

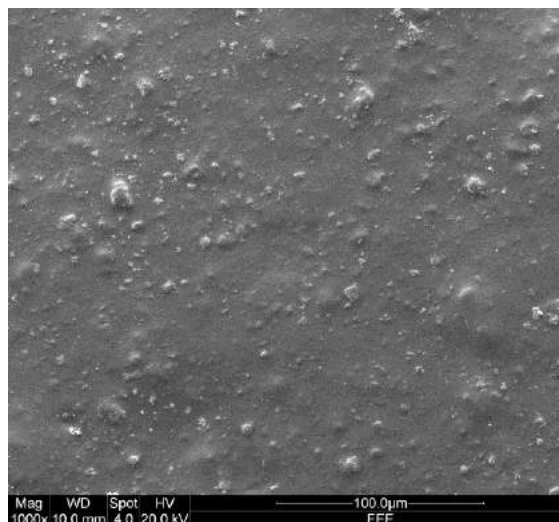

Paint-brushed Aged Red

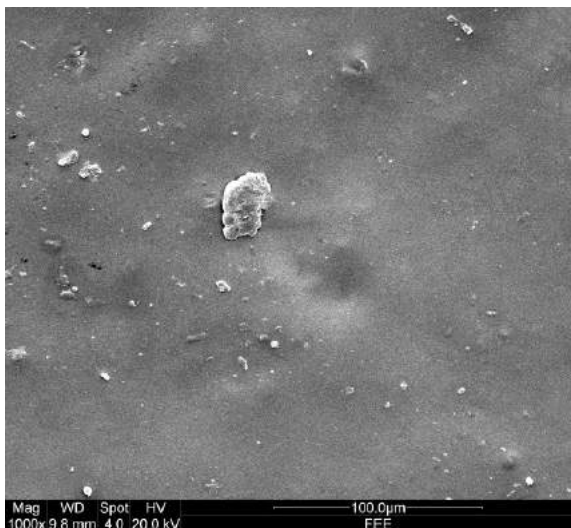

Airbrushed Aged Yellow

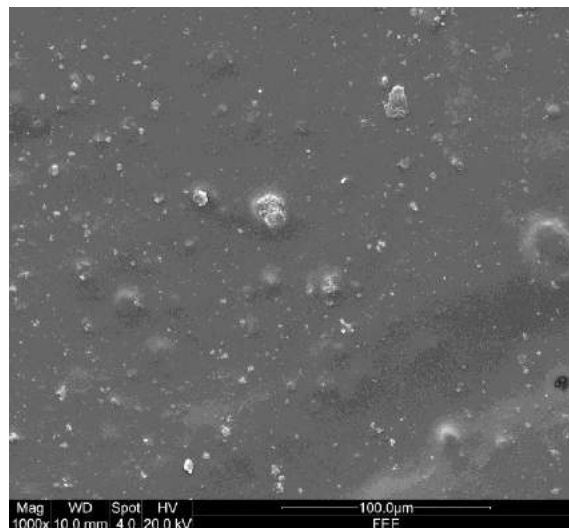

Paint-brushed Aged Yellow

A.3.2 SEM Imaging (Samples Group 1): b. Airbrushed non-aged vs. paint-brushed non-aged

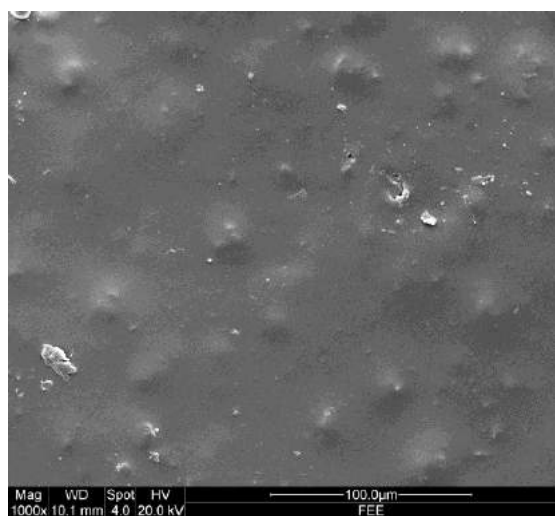

Airbrushed Non-Aged Cyan

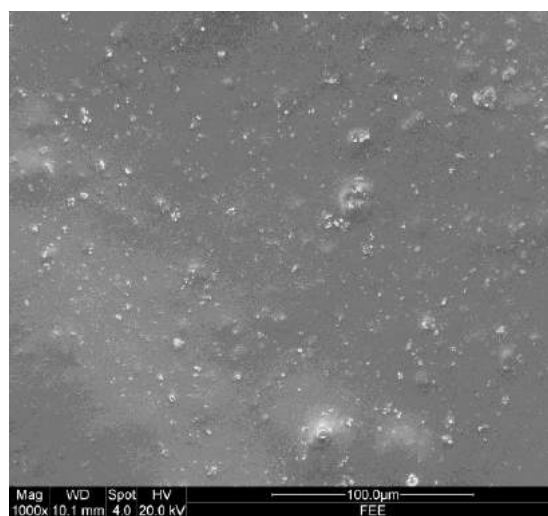

Paint-brushed Non-Aged Cyan

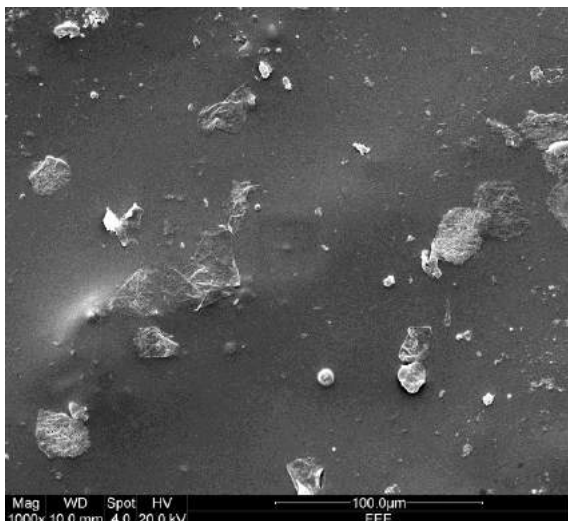

Airbrushed Non-Aged Red

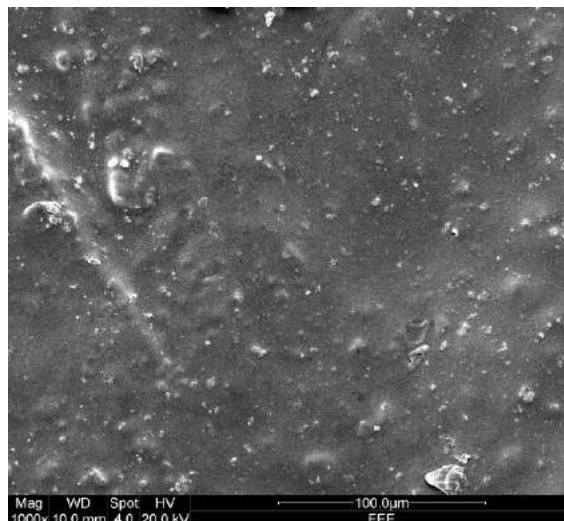

Paint-brushed Non-Aged Red

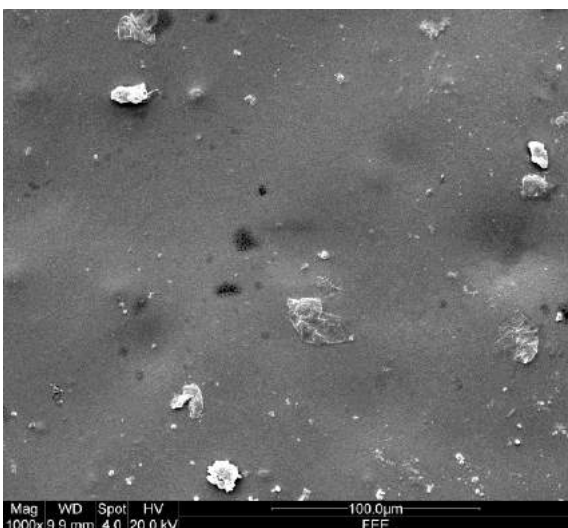

Airbrushed Non-Aged Yellow

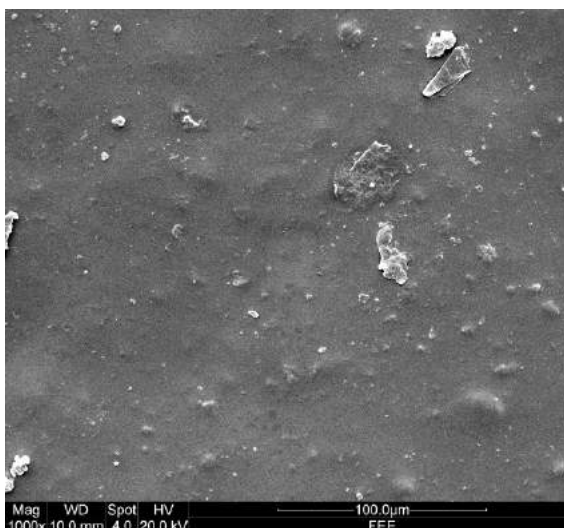

Paint-brushed Non-Aged Yellow

A.3.3 SEM Imaging (Samples Group 2): a. Airbrushed Aged vs. paint-brushed aged

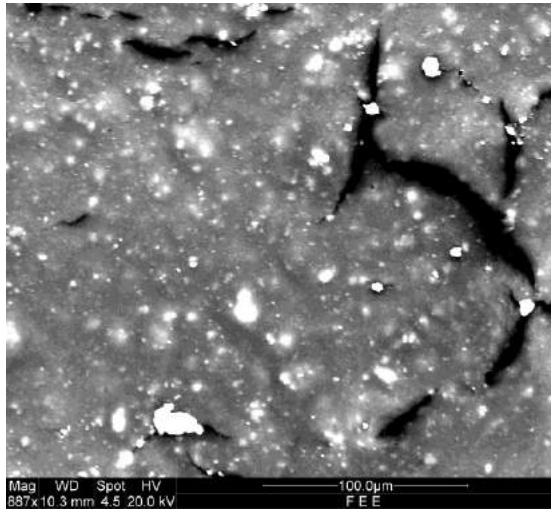

Airbrushed Aged Cyan

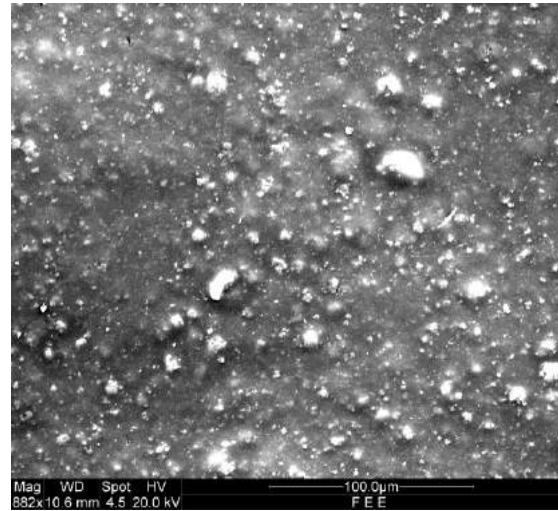

Paint-brushed Aged Cyan

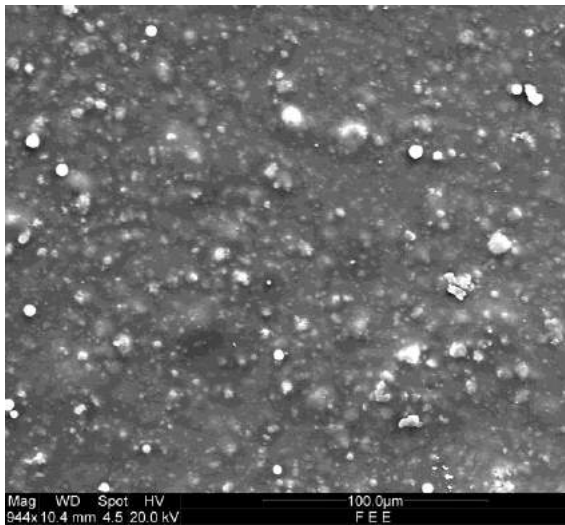

Airbrushed Aged Red

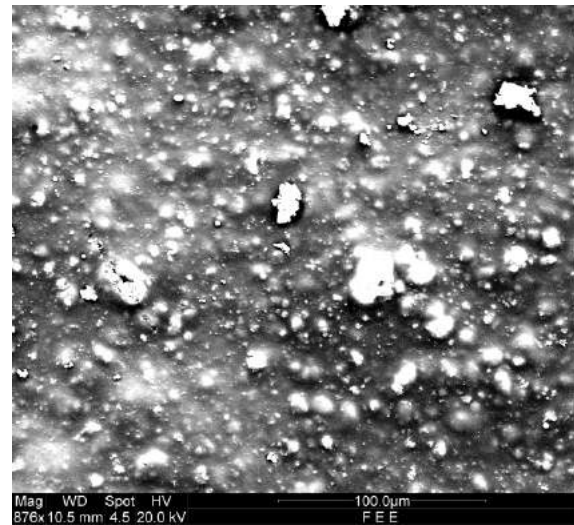

Paint-brushed Aged Red

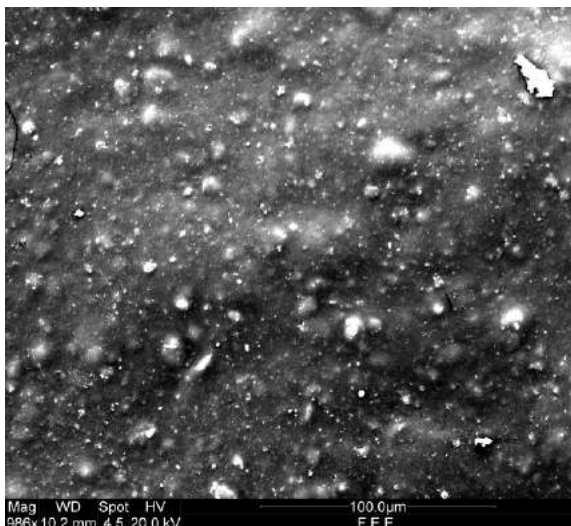

Airbrushed Aged Yellow

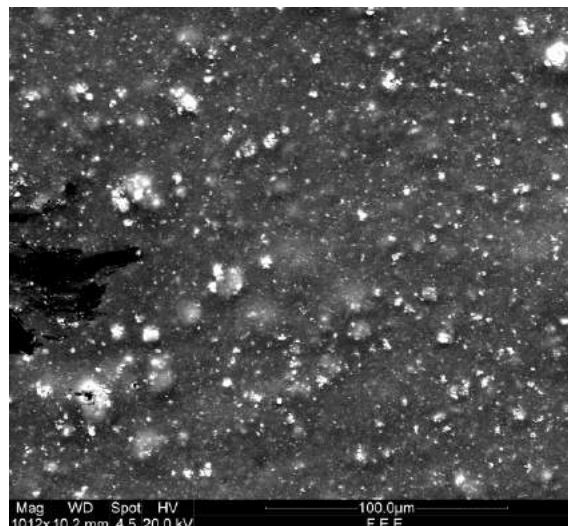

Paint-brushed Aged Yellow

A.3.4 SEM Imaging (Samples Group 2): b. Airbrushed non-aged vs. paint-brushed non-aged

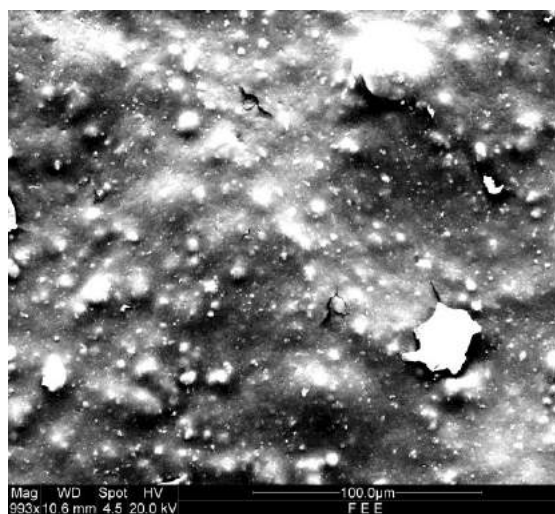

Airbrushed Non-Aged Cyan

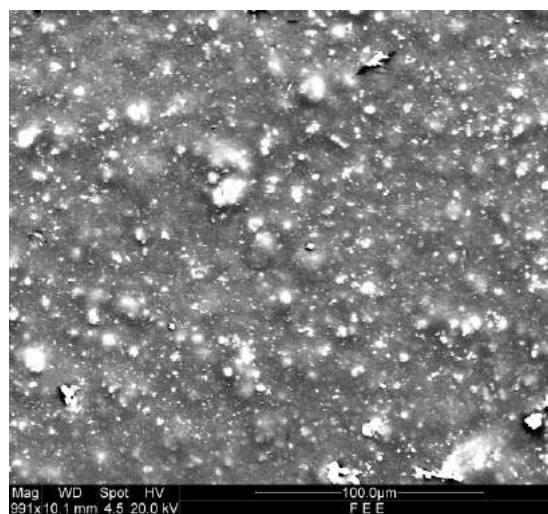

Paint-brushed Non-Aged Cyan

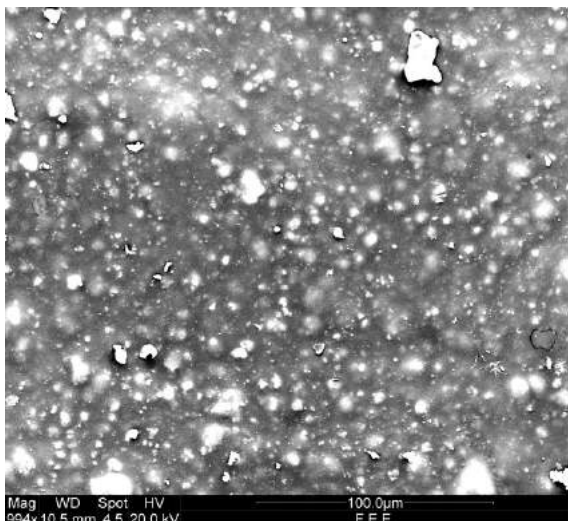

Airbrushed Non-Aged Red

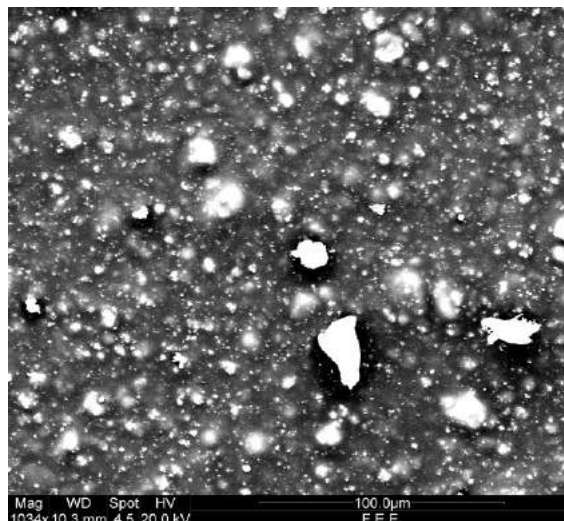

Paint-brushed Non-Aged Red

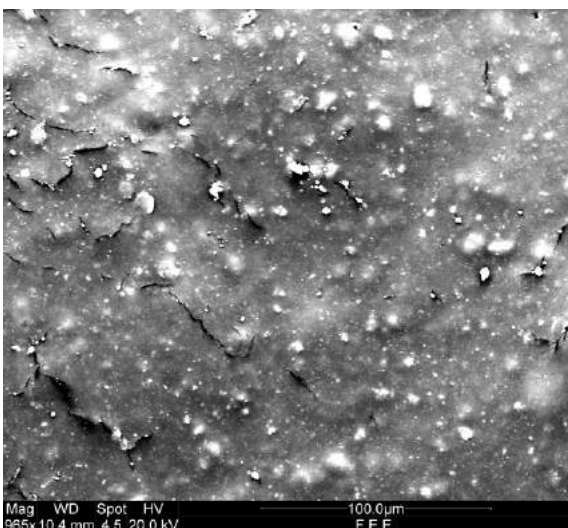

Airbrushed Non-Aged Yellow

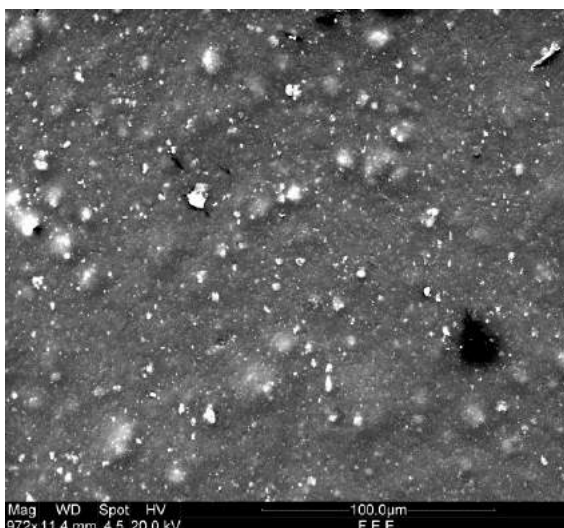

Paint-brushed Non-Aged Yellow