

# Northumbria Research Link

Citation: Chan, Lydia, Shyha, Islam, Dreyer, Dale, Hamilton, John and Hackney, Philip (2016) Weld overlay cladding repair - An investigation of tensile strength variation in processed metallic substrate. In: International Conference on Advances in Mechanical Engineering, 10-13 May 2016, Istanbul.

URL:

This version was downloaded from Northumbria Research Link:  
<http://nrl.northumbria.ac.uk/27167/>

Northumbria University has developed Northumbria Research Link (NRL) to enable users to access the University's research output. Copyright © and moral rights for items on NRL are retained by the individual author(s) and/or other copyright owners. Single copies of full items can be reproduced, displayed or performed, and given to third parties in any format or medium for personal research or study, educational, or not-for-profit purposes without prior permission or charge, provided the authors, title and full bibliographic details are given, as well as a hyperlink and/or URL to the original metadata page. The content must not be changed in any way. Full items must not be sold commercially in any format or medium without formal permission of the copyright holder. The full policy is available online: <http://nrl.northumbria.ac.uk/policies.html>

This document may differ from the final, published version of the research and has been made available online in accordance with publisher policies. To read and/or cite from the published version of the research, please visit the publisher's website (a subscription may be required.)

[www.northumbria.ac.uk/nrl](http://www.northumbria.ac.uk/nrl)



**CONFERENCE ON ADVANCES IN MECHANICAL ENGINEERING ISTANBUL 2016 – ICAME2016  
10-13 May 2016, Yildiz Technical University, Istanbul, Turkey**

**WELD OVERLAY CLADDING REPAIR –  
AN INVESTIGATION OF YIELD STRENGTH VARIATION IN METALLIC SUBSTRATE**

**Lydia Chan**

Northumbria University, Renown Group  
Newcastle upon Tyne, Tyne and Wear  
United Kingdom

**\*Islam Shyha**

Northumbria University  
Newcastle upon Tyne, Tyne and Wear  
United Kingdom

**Dale Dreyer**

Renown Group  
Washington, Tyne and Wear  
United Kingdom

**John Hamilton**

Renown Group  
Washington, Tyne and Wear  
United Kingdom

**Phil Hackney**

Northumbria University  
Newcastle upon Tyne, Tyne and Wear,  
United Kingdom

*Keywords: weld overlay cladding; superalloy stack; weld repair; tensile strength*

*\* Corresponding author Phone: +44 (0)191 243 7834*

*E-mail address: islam.shyha@northumbria.ac.uk*

## **ABSTRACT**

Weld Overlay Cladding (WOC) is a surfacing technique commonly applied on subsea Oil and Gas components to provide additional properties such as wear and corrosion resistance at a more superior level. This process involves a clad metal with certain desirable characteristics – tends to be a superalloy – being fusion-welded onto a lower cost standard metallic substrate such as steel. In some cases, a repair is required to recondition damaged or corroded clad surfaces. This paper presents an investigation on tensile strength variation that occurs in the metallic substrate post-repair. Tensile tests were carried out on specimens extracted from a repaired substrate and a section of unclad substrate. Results were compared and have shown that variations occurred in both pieces – neither were close to the values stated on the material certificate or previous test certificate. Through literature review, suggestions were made for the reasons behind this phenomenon. Recommendations were proposed as to how such non-uniformity can be prevented or rectified through amending material procurement and cladding procedure.

## **INTRODUCTION**

In the Oil and Gas industry, most components operate under extreme conditions especially high acidity. To combat against corrosion, weld overlay cladding (WOC) is performed

on the surfaces that are exposed to such environment whereby several layers of superalloy (e.g. Alloy 625) are welded onto a basic metallic substrate. This method is employed as it is a more cost-effective and flexible solution opposed to manufacturing solid superalloy parts.

In some cases, a repair is required to recondition used components or rectify imperfection on a new part. The repair involves removing the original layer of superalloy along with its heat affected zone on the substrate, then applying new layers until the desired thickness has been reached.

There is speculation that such a process would introduce surplus heat into the substrate, causing the material properties to diminish significantly. Variation may occur, which causes non-uniform distribution of properties. It is highly possible that these effects would lead to rejection of parts as the specification requirements might not be met.

The present work focuses on investigating the possible causes of tensile strength variation with the aim to minimise the influences from the cladding and repair process. Literature survey and experimentation were carried out to gain an understanding of the effects. Upon analysing the results, recommended actions were suggested to aid eliminating such variations.

## LITERATURE SURVEY

### Substrate Manufacture Conditions

There are multiple grades to a standard material based on adjusting chemical compositions or forging heat treatments. Relevant criteria often vary depending on the client's specification for different products. All material should therefore arrive with a certificate provided by the supplier as a proof of passing the stated requirements.

From molten metal to forged bars, there are many stages of material processing that could affect the output properties. As the material is cast, there is no particular grain flow of microstructure within. The ingot structure consists of three parts: chill zone, columnar zone, and equiaxed zone (see Figure 1). This non-uniformity often carries impurities which are eradicated in the subsequent heat treatment. Depending on the cooling rate, shrinkage would occur to a certain degree due to contractions during solidification, which could lead to water vapour being trapped and condense internally. This would cause defects during the forging process [1]. Therefore it is crucial to ensure any shrinkage is removed from the ingot if it occurs before being forged into a billet.

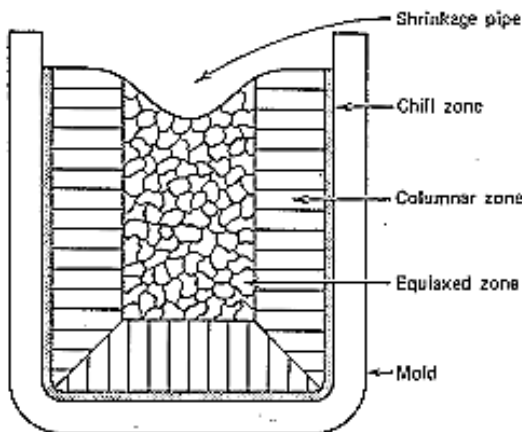

Figure 1 – Cast ingot structure [2]

It is known that material properties tests are performed on only one of the ends of a billet. It is possible that the billet was subjected to uneven heat treatment causing non-uniform distribution of microstructure across the material.

In manufacture, heat treatment plays a key role in defining the microstructure of a material. This process includes normalising, austenitising, quenching, and tempering cycles at various temperatures for a set amount of time. All parameters are standardised as stated in the procedure. It is important to gain homogeneity in grain size of microstructure as this would provide uniform mechanical property throughout [3]. Some research has observed a variation in material properties that exist in larger steel forgings due to uneven heat treatment during production [4, 5]. Even though the work piece in this case is not as large, it is worthwhile to briefly examine properties distribution in the substrate.

### Post Weld Heat Treatment

During the welding process, a large amount of heat is applied to bond the filler metal and the substrate. A certain level of residual stress is introduced, which has to be rectified at a later stage through post weld heat treatment (PWHT). It is a controlled process, where the temperature is set to be around 30°C below the tempering temperature of the substrate and the cooling rate is increased over the range of 400°C - 600°C, in order to avoid temper embrittlement [6, 7].

The effect of PWHT on the substrate and heat affected zone (HAZ) were previously studied by Hassel [8] and Hodgson et al. [9]. Surprisingly, both researches have suffered from the effect of initial material incompliance. Nonetheless, there is evidence to validate that this type of substrate is applicable to the Hollomon-Jaffe parameter (HJP), which describes the material's dependency on heat treatment temperature and duration. Figure 2 shows that the validation of HJP by mapping hardness reduction against equivalent treatment duration and temperature, though with a single anomaly. Furthermore, the substrate microstructure exhibited similar transformation under PWHT in both studies.

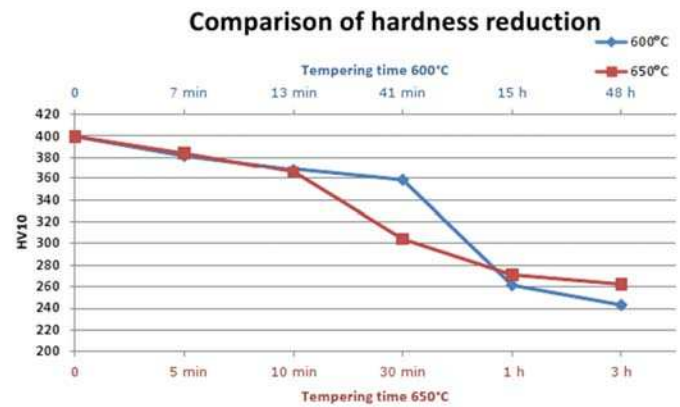

Figure 2 – Hardness reduction mapped against equivalent treatment duration of two temperatures according to HJP [8]

Research by Hassel is particularly relevant to the current work. It confirmed the possibility that the tensile properties were being affected by PWHT. Material properties variation was found to have a strongly dependency on the heat treatment temperature. Material of similar chemical composition has also been studied and displayed comparable PWHT effect on microstructure and mechanical properties [10].

Moreover, there have been reports suggesting repair welding on chromium-molybdenum can be implemented without PWHT [11, 12]. Procedure of such practice was developed on the premise that the substrate and filler metal can be heat treated by each subsequent layer of weld deposit. It is reported that such process reduced production time and was more effective than a separate PWHT [13].

### Material Properties Variation

Steel inherits a linear correlation between tensile strength and hardness by nature [14]. This relationship remains unchanged even after weld and PWHT for the substrate as confirmed by Hassel [8]. Hardness level is governed by three parameters: 1) cooling rate through transformation temperature range, 2) material composition and hardenability value, 3) original microstructural grain size. [15] Therefore it is important to gain control over these parameters in order to achieve desired conditions.

With regards to chemical composition, it has been found that % weight of carbon content significantly affect the hardness level. [16] For substrate used in oil and gas products, the accepted range of carbon content is between 0.05%wt and 0.15%wt and the hardness variation of several groups of samples is as shown in Figure 3. As hardness correlates to the martensitic microstructures distribution within material, it is inevitable that the hardness, hence tensile strength, would vary section-to-section. This has given more reason to examine material properties across the substrate.

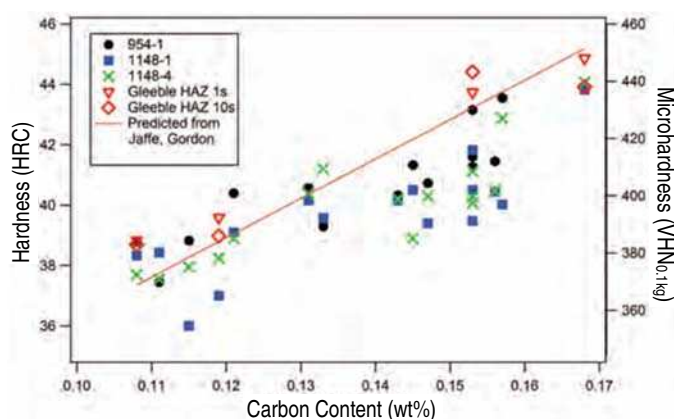

Figure 3 – Hardness and Carbon Content relationship in typical Oil and Gas metallic substrate [9]

Heat input from the welding process also plays a part in material properties variation. In theory, the only section that would be affected by such is the HAZ immediately beneath the fusion zone and so PWHT conditions are designed to target this area. There is a chance for overtreatment in the substrate beyond the HAZ, which could lead to a weaker material. Secondary hardening during PWHT would also cause non-uniformity in material. Figure 4 illustrates this effect which occurs at certain HJP index. It is clear that the experiments in [9] showed an apparent secondary hardening effect at HJP 19.084 (638°C for 9 hours) and a minor effect at HJP 18.562 (647°C for 1.5 hours). However this might differ depending on the dimension of the piece as the wall thickness is the determinant of most heat treatment parameters.

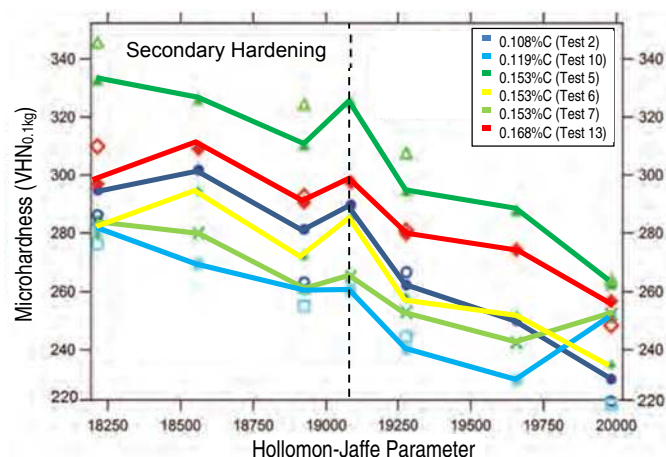

Figure 4 – Hardening behaviour of substrate over the course of PWHT [9]

### EXPERIMENTATION

Two sets of experiments were designed to investigate the variations in tensile strength between as-received material and WOC repaired material. Longitudinal specimens were extracted from corresponding coupons. As common to Oil and Gas components, low alloy Chromium-Molybdenum steel was chosen to be the substrate material and a Nickel-based superalloy to be the cladding material. WOC repair procedure was simulated on one of the coupons whereby the original material was overlaid with multi-stacks cladding but a section was intentionally removed later to act as the repair zone. New stacks of cladding are overlaid until the original height was reached to complete the repair process.

All tensile tests were carried out on INSTRON3382 Electromechanical Testing System which had been calibrated prior to experimentation. The load measurement accuracy is  $\pm 0.50\%$ . Prior to each test, gauge diameter and length of the specimens were individually measured with a pair of calibrated digital vernier calipers that has an accuracy of  $\pm 0.01\text{mm}$ . Tests were completed in accordance to ASTM A370 standard.

#### Group A Specimens

An offcut of an as-received forging was selected for this experiment. The supplier material certificate was retrieved and used as reference. The aim of which was to investigate the initial variation in tensile strength within the material at its pre-process stage. The piece was cut into segments around the circumference and two specimens were extracted from each as illustrated in Figure 5. A total of 24 specimens were extracted.

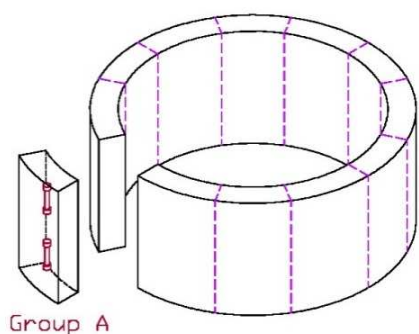

Figure 5 – Extraction locations of Group A specimens

### Group B to E Specimens

Specimens were extracted from the WOC repair simulated coupon, which would aid the investigation of the change in tensile strength post-production and the effect of heat input from the cladding process. The as-received material certificate was retrieved and used as reference to compare changes in material properties.

Group B was extracted at locations where there is no cladding on the surface (i.e. away from the repaired zone) – 8 specimens were extracted. Group C to E were extracted directly beneath the repaired zone at evenly spaced incremental depth with Group C closest to the cladding and Group E closest to the outer surface. 4 specimens were extracted from each depth – a total of 12. These locations and extraction sequence are illustrated in Figure 6.

A segment of the coupon was sent to an approved test house for official examination, from which the results were compared against the laboratory results for confirmation.

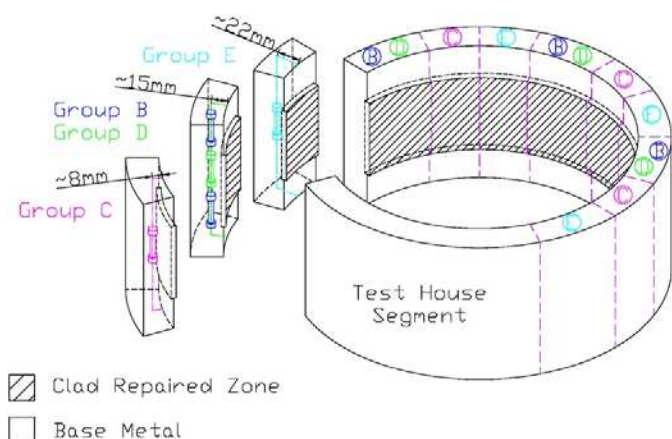

Figure 6 – Extraction locations of Group B to E specimens

### Specimen Dimensions

All specimens were machined to match the dimensions for the standard laboratory equipment setup. Each had a central section diameter of 5.00mm and a reduction section length of

26.50mm with a 1mm radius fillet connecting to the end sections as illustrated in Figure 7.

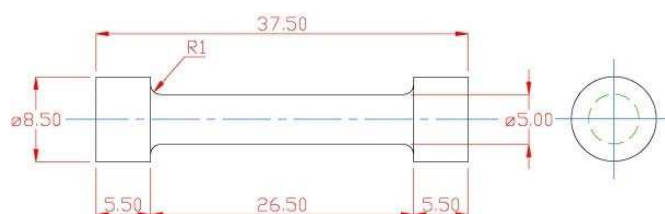

Figure 7 – Tensile test specimen dimensions (dimensions in mm)

## RESULTS AND DISCUSSION

The yield point of low alloy steel cannot be easily defined based on its stress-strain curve, therefore an offset value, known as 0.2% yield strength, is often used in place of true yield point.

The applied loading rate was set to 137.90MPa/min (20,000psi/min). In other terms, the crosshead separation speed was set to 1.00mm/min. Each specimen was tested to destruction. The gauge diameter value of individual specimen was input into the system in the beginning of each run.

As the gauge diameter was being measured prior to testing, it was discovered that three specimens from Group B were slightly tapered. Even though the necking and failure point was towards the narrow end, no difference was observed in the result in comparison with non-tapered specimens.

### As-received Forgings (Group A)

All 24 specimens in Group A were tested. Results of the 0.2% yield strength are displayed in Figure 8. Value on the original material certificate ( $m$ ) and a typical specification requirement range ( $r_1$  &  $r_2$ ) are also indicated on the chart.

As shown, all results were within the typical specification requirement limits; however all are skewed towards the lower limit. Specimen A5 and A22 in particular have the lowest yield strength values which might have included possible instrumental error in the testing system.

None of the specimens has a yield strength that matches the stated value on the material certificate. The difference between the average and the stated value is rather significant. The original tensile test specimen for producing material certification could have been an outlier. This suggests a discrepancy between certificate and material. The existence of anomalous specimens and yield strength various indicates that there is a non-uniform distribution of material properties throughout the piece, which is suspected to be inherited from uneven heat treatment on the forging during manufacturing process.

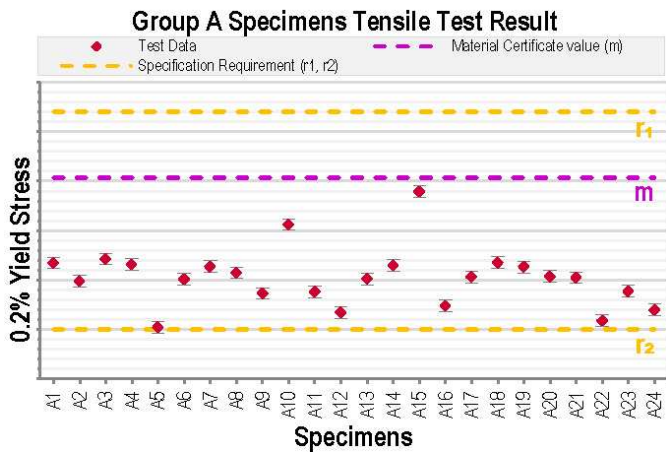

Figure 8 – Tensile test results for Group A specimens<sup>1</sup>

With regards to the WOC and any repair, it is commonly stated in the client’s specification that the resultant 0.2% yield strength should be no greater than a certain amount,  $c$ , below value  $m$ , i.e.  $\geq(m-c)$ , unless stated otherwise. Given that the yield strength of as-received forging is already on the lower end between  $r_1$  and  $r_2$ , the finished workpiece will naturally prone to failure.

**WOC Repair Process and Heat Treatment (Group B to E)**

Specimens, a total of 20, from the WOC repair simulated coupon were tested (Group B, C, D, and E). Results of the 0.2% yield strength are displayed in Figure 9. The original pre-production tensile strength that was stated on the material certificate ( $m$ ), the official result from the test house ( $t$ ), and the common specification requirement ( $m-c$ ) are also indicated on the chart.

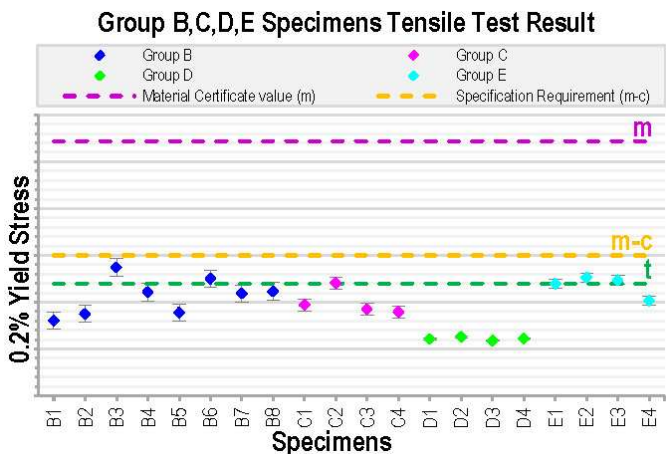

Figure 9 – Tensile test results for Group B, C, D, and E<sup>1</sup>

It is clear that all specimens tested in Group B to E are below the specified requirement in terms of yield strength,

including the segment of coupon examined by the test house. This confirms that neither set of results were anomalous. The average 0.2% yield strength results within each specimen group were calculated and ranked from highest to lowest – 1 to 4 respectively. This is illustrated in Figure 10. Group E had the highest value while Group D had the lowest.

From this set of data, the thermal effect from the WOC process and PWHT can be seen. When comparing yield strength values across the groups, the differences between each show that thermal effect caused by the welding process is present. It is known that HAZ exists below the welded layer. The surrounding material has found to have been affected to a certain degree as well. The closer to the clad layer, the more affected it is due to heat penetration from the welding torch. This effect is illustrated in Figure 11a. As each section of the material was exposed to different levels of heat, each would have experienced a different thermal gradient hence resulting in varying degrees of residual stress within the material.

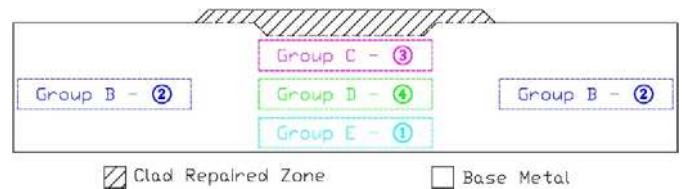

Figure 10 – Group B to E Tensile test result ranking

The heat penetration pattern of PWHT could also be a cause of non-uniform property distribution. In theory, the subsequent PWHT should unify and return the material to its original state. However since the mechanical properties of each section of material has been altered differently due to the various amount of residual stress, it is likely that the resultant effect would follow such pattern.

Furthermore, the material experienced PWHT at a different rate because of the cladding which has a lower thermal conductivity. This means that the substrate sections below the cladding would require a longer period of time to reach the treatment temperature and therefore had shorter heat exposure duration in comparison with other sections that are closer to unclad surfaces. The cooling rate afterwards would also differ accordingly. This effect is illustrated in Figure 11b, showing the distributed PWHT effect within the material.

With both welding and PWHT effects combined, it can be seen that the moderately affected zone was only subjected to low level of PWHT which resulted in below average 0.2% yield strength.

<sup>1</sup> No actual values are shown due to confidentiality agreement

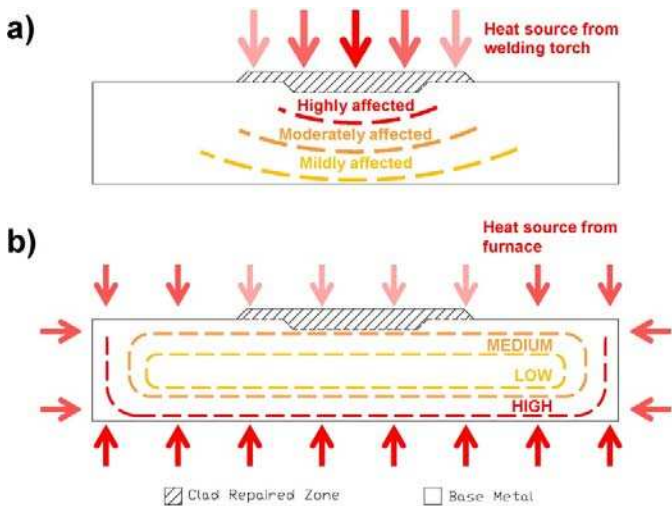

Figure 11 – Illustrations of a) heat penetration from welding torch, and b) heat penetration from PWHT

## CONCLUSION

A total of 24 and 20 specimens were extracted from an as-received forging and a simulated weld overlay cladding repair coupon respectively, which underwent tensile testing till destruction. Load and displacement were measured; the 0.2% yield strength was calculated subsequently. Results were compared against the original material certificates and specification requirements.

From analysis, the data indicated that there is a discrepancy in 0.2% yield strength between the material certificate and its actual properties which were found to be significantly lower on average. This would lead to a lesser resultant tensile strength that has a high potential of failing to meet specification requirements. A variation of properties within the material was observed. Even though the variation occurred within the specification limits, it was at the lower end where one of the specimens was almost out of bound. It is, therefore, recommended that it would be worthwhile to assess the properties of newly procured material for additional examination to concur with the information stated on the supplier's certificate. It is also recommended to evaluate the specification requirement boundaries and establish a wider bracket to avoid excessive loss of material strength during any WOC process.

Furthermore, a distribution of yield strength was detected within simulated WOC repair coupon. The highest yield strength specimen located adjacent to the outer surface whereas the lowest located midway between the welded and outer surface. These are clear signs that the specified PWHT might not be sufficient in treating metal substrate. The clad layer might have restricted heat penetration to some degree from the inner bore to the substrate. It is advised that the heat input from WOC and the PWHT conditions are to be reviewed in order to reduce the effect of under-treatment. If the material properties

are still persistently lower than the specification, it suggests that there is an underlying problem in the original material or how the material was examined initially. It is recommended to discuss with the supplier to agree on a more thorough process in examining material.

This paper has provided an overview of some possible answers and potential solutions to explain and prevent yield strength variation within metallic substrate that was involved in WOC repair process. As the sample size is very small, the results presented in the current work would not be entirely conclusive. Further investigation in PWHT and WOC procedure are being carried out to gain a bigger picture of how the metallic substrate is affected by each process.

## ACKNOWLEDGMENTS

The authors gratefully acknowledge Renown Group for facilitating this project, and funding it along with Innovate UK through the Knowledge Transfer Partnership Scheme. Gratitude also goes to the Department of Mechanical and Construction Engineering at Northumbria University for providing resources.

## NOMENCLATURE

HAZ	Heat Affected Zone
HJP	Hollomon-Jaffe Parameter
PWHT	Post Weld Heat Treatment
WOC	Weld Overlay Cladding

## References

- [1] D. Askeland and P. Fulay, *Essentials of Materials Science and Engineering*, 2nd ed., Nelson Engineering, 2009.
- [2] J. Verhoeven, *Fundamentals of Physical Metallurgy*, John Wiley & Sons Inc., 1975.
- [3] H. Bhadeshia and R. Honeycombe, *Steels: Microstructure and Properties*, 3rd ed., Butterworth-Heinemann, 2006.
- [4] P. Thornton and V. Colangelo, "Variation of mechanical properties in large steel forgings," *Metallurgical Transactions B*, vol. 7, no. 3, pp. 425-433, 1976.
- [5] W. Li, J. Cai, L. Chuzhoy, D. Sherman, K. Erickson and R. Shaikh, "Multiscale Heat Treat Simulation and Performance Modeling of Large Steel Components," in *Heat Treating 2005: Proceedings of the 23rd Conference (ASM International)*, 2006.
- [6] T.W.I Ltd, "What is temper embrittlement, and how can it be controlled?," 2015. [Online]. Available: <http://www.twi-global.com/technical-knowledge/faqs/material-faqs/faq-what-is-temper-embrittlement-and-how-can-it-be-controlled/>. [Accessed 13 April 2015].
- [7] H. Granjon, *Fundamentals of Welding Metallurgy*, Woodhead Publishing Ltd, 1991.
- [8] T. Hassel, "Effects of Heat Treatment on Microstructure,

- Strength, and Hardness of F22 Steel,” Norwegian University of Science and Technology, 2013.
- [9] D. Hodgson, T. Dai and J. Lippold, “Transformation and Tempering Behavior of the Heat-Affected Zone of 2.25Cr-1Mo Steel,” *Welding Journal*, vol. 94, no. 8, pp. 250s-256s, 2015.
- [10] N. Tammasophon, W. Homhrajai and G. Lothongkum, “Effect of Postweld Heat Treatment on Microstructures and Hardness of TIG Weldment between P22 and P91 Steels with Inconel 625 Filler Metal,” *Journal of Metals, Materials and Minerals*, vol. 21, no. 1, pp. 93-99, 2011.
- [11] T.W.I Ltd, “Repair welding Cr-Mo steels without PWHT,” 2015. [Online]. Available: <http://www.twi-global.com/news-events/case-studies/repair-welding-cr-mo-steels-without-pwht-317/>. [Accessed 13 April 2015].
- [12] A. Aloraier, A. Al-Mazrouee, J. Price and T. Shehata, “Weld repair practices without post weld heat treatment for ferritic alloys and their consequences on residual stresses: A review,” *International Journal of Pressure Vessels and Piping*, vol. 87, pp. 127-133, 2010.
- [13] L. Friedman, “EWI/TWI controlled deposition repair welding procedure for 1.25Cr-0.5Mo and 2.25Cr-1Mo steels,” *Welding Research Council Bulletin*, no. 412, pp. 27-34, 1996.
- [14] E. Pavlina and C. Van Tyne, “Correlation of Yield Strength and Tensile Strength with Hardness for Steels,” *Journal of Materials Engineering and Performance*, vol. 17, no. 6, pp. 888-893, 2008.
- [15] T.W.I Ltd, “What is the relationship between hardness, microstructure and toughness in steel heat affected zones?,” 2015. [Online]. Available: <http://www.twi-global.com/technical-knowledge/faqs/material-faqs/faq-what-is-the-relationship-between-hardness-microstructure-and-toughness-in-steel-heat-affected-zones/>. [Accessed 17 04 2015].
- [16] G. Krauss, “Martensite in Steel: Strength and Structure,” *Materials Science and Engineering: A*, Vols. 273-275, pp. 40-57, 1999.
- [17] H. Bhadeshia and R. Honeycombe, *Steels: Microstructure and Properties*, 3rd ed., Elsevier Ltd, 2006.
- [18] L. Jaffe and E. Gordon, “Temperability of Steels,” *Transactions of American Society for Metals*, vol. 49, pp. 359-371, 1957.
- [19] ASTM A370, *Standard Test Methods and Definitions for Mechanical Testing of Steel Products*.