

University of Warwick institutional repository: <http://go.warwick.ac.uk/wrap>

A Thesis Submitted for the Degree of PhD at the University of Warwick

<http://go.warwick.ac.uk/wrap/3445>

This thesis is made available online and is protected by original copyright.

Please scroll down to view the document itself.

Please refer to the repository record for this item for information to help you to cite it. Our policy information is available from the repository home page.

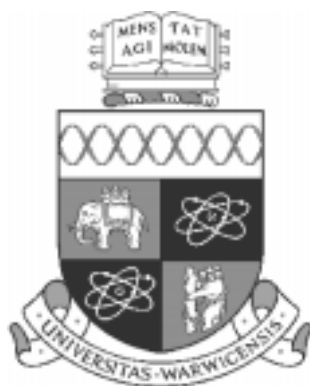

Technology for Humanitarian Landmine Clearance

Russell Gasser

Thesis submitted to the University of Warwick
for the degree of Doctor of Philosophy

Development Technology Unit
School of Engineering
University of Warwick
Coventry CV4 7AL
UK

September 2000

Contents

List of figures	v
List of tables	viii
Acknowledgements	x
Declaration	x
Summary	xi
1 Introduction	1
1.1 The impact of mines	1
1.2 The need for new technologies	2
1.3 Technology transfer	3
1.4 Scope of this thesis	3
1.5 Contents of this thesis	4
2 An overview of humanitarian demining	7
2.1 Introduction	7
2.2 A brief history of landmines and demining	7
2.3 Definition of “mine”	9
2.4 The difference between military and humanitarian demining	9
2.5 Mine clearance strategies	10
2.6 Surveying mined areas	11
2.6.1 The different “levels” of survey	11
2.7 Humanitarian demining methodology	17
2.8 Safety	27
2.9 Summary	27

3	Defining the problem — a review of the literature.	28
3.1	Introduction	28
3.1.1	The dominance of buried mine detection in research	28
3.2	“The view from the field” and “The view from the lab”	29
3.3	Technologies for demining	31
3.4	Literature covered elsewhere in the thesis	32
3.5	Prodding	32
3.5.1	Mechanised prodding	32
3.5.2	Acoustic prodders	33
3.5.3	Easy entry or Low force prodders	34
3.6	Equipment development: areas without a formal literature	34
3.6.1	Vegetation Clearance - an essential precursor to location	34
3.6.2	Other technologies lacking a formal literature	35
3.7	The statistical analysis of test results	35
3.8	Optimising demining research	36
3.8.1	Ground penetrating radar (GPR) as an example of research	36
3.9	Summary	37
4	The problem of evaluating the performance of mine detection systems	39
4.1	Introduction	39
4.2	The three main problems in testing demining equipment	40
4.3	The statistics of missed mines	41
4.3.1	A conceptual model	41
4.3.2	Definition of the problem of sampling	42
4.3.3	Analysis using the Binomial probability distribution	42
4.3.4	Using trial outcome to predict p_D	44
4.3.5	Selection of p_D and confidence	46
4.4	Qualitative factors	48
4.4.1	Limitations of “crude detection rate” data	49
4.4.2	Human factors	49
4.4.3	False alarms and unwanted alarms	49

4.5	Quality Assurance	50
4.6	“Margin of detection”	52
4.6.1	Application of “margin of detection” to QA	55
4.6.2	Use of unwanted alarms and margin of detection to enhance QA	55
4.7	Summary and conclusions	56
5	Research into improved prodding	57
5.1	Introduction	57
5.2	Sensing prodders: Location and discrimination from ‘close-in’	59
5.3	Proof-of-concept sensing prodders	59
5.3.1	Metal detector prodder	61
5.3.2	Differential magnetometer prodder	62
5.3.3	Acoustic prodders	65
5.3.4	Ultrasound prodder	67
5.4	The problems of prodding in hard ground	69
5.4.1	Do deminers push too hard while prodding?	69
5.4.2	Measurement of force used while prodding	71
5.5	Laboratory work developing rotary prodders	76
5.5.1	General specification for demining tools	76
5.5.2	Rotary Prodders	76
5.6	Field testing of rotary prodders in Cambodia	82
5.6.1	Equipment used	82
5.6.2	Results of testing rotary prodders in Cambodia	84
5.6.3	Deminer reaction to rotary prodders	85
5.7	Re-analysis of the original ideas	87
5.7.1	The difference between prodding and excavation	87
5.7.2	Sensing prodders — is more information useful?	87
5.8	Force sensing prodders for training	88
5.8.1	Field testing a buzzing prodder in Afghanistan	89
5.9	Conclusions	90
6	Neutron detection of explosives	107

6.1	Introduction	107
6.2	Neutron methods in current use	108
6.2.1	Explosive detection	108
6.2.2	Other relevant applications of neutrons	111
6.3	Current research work on neutron detection of mines	112
6.3.1	A review of the literature	112
6.3.2	Gaps in the literature	114
6.4	Detection criteria and statistics	115
6.5	Neutron properties & generation, neutron & gamma-photon detection	117
6.5.1	Neutron properties and reactions	117
6.5.2	Neutron sources	118
6.5.3	Advantages and disadvantages of electronic neutron sources.	118
6.5.4	Disadvantages of radioisotope neutron sources.	119
6.5.5	Switched radioisotope sources	120
6.5.6	Neutron filtering	121
6.6	Radiation Protection and operator safety	122
6.6.1	Standard method of calculating radiation hazard	122
6.6.2	Neutron shielding	122
6.6.3	Appropriate radiation safety levels for minefield equipment	122
6.7	Specific problems of neutron methods in demining	125
6.7.1	Adequate neutron flux at mine	125
6.7.2	Soil moisture	127
6.7.3	Soil nitrogen	130
6.7.4	Soil silicon	132
6.7.5	Time to detect	134
6.8	Possible strategies for optimising neutron techniques	135
6.8.1	Plastic mine cases	135
6.9	Conclusions	137
7	Conclusions and recommendations for further work	141
7.1	The context of humanitarian demining research	141
7.1.1	The nature of the problem	141

7.1.2	The influence of military demining	142
7.2	The existing literature	142
7.3	Research work in this thesis	142
7.3.1	Statistical analysis	142
7.3.2	Improved prodders	142
7.3.3	Neutron detection of explosive (detection of prompt gamma rays generated by neutron irradiation)	143
7.4	Further work	144
A	Discussion of the question “Should we try to identify mines?”	146
B	Neutron properties & interactions	150
B.1	Neutron properties	150
B.2	Neutron generation	151
B.2.1	Portable accelerator tubes	152
B.2.2	Radioisotope neutron sources	153
B.3	Detection of neutrons and gamma radiation	154
B.3.1	Neutron detection	154
B.3.2	Gamma detection	154
C	Radiation safety and neutron shielding	156
C.1	Radiation safety	156
C.2	Neutron shielding	157
C.2.1	Shielding effect of resonant materials.	158
D	Computer Program for data logging	160
	Glossary of demining terms	161
	Bibliography	165

List of Figures

2.1	Map of Glinska Poljana, Croatia showing locations of mines/UXO . . .	12
2.2	Overgrown mined areas in Cambodia.	14
2.3	Vegetation clearance using a flail on a long boom on an armoured tractor.	15
2.4	Tempest remote-control mini-flail with custom built blast resistant hull.	16
2.5	Sequence of operations, manual demining in Cambodia (part 1). . . .	18
2.6	Sequence of operations, manual demining in Cambodia (part 2). . . .	19
2.7	Sequence of operations, manual demining in Cambodia (part 3). . . .	20
2.8	Elimination of small UXO by blow-in-situ.	21
2.9	Prodding and excavation in hard dry soil in Cambodia.	22
2.10	Sequence of operations, clearance using dogs in Afghanistan (part 1).	23
2.11	Sequence of operations, clearance using dogs in Afghanistan (part 2).	24
2.12	Deminer being trained to new SOPs which permit working in a squatting position.	25
2.13	Antipersonnel mines.	26
4.1	Probability of result vs assumed probability of detection for trials of 100 mines.	43
4.2	Probability of result vs probability of detection for a trial of 100 mines.	45
4.3	Minimum probability of detection vs confidence in the result, for trials in which all the mines are detected.	46
4.4	Probability of detection vs size of trial when the minimum probability of detection is numerically equal to the confidence in the result. . . .	48
5.1	Combined prodding/excavating tool.	58
5.2	Metal detector prodder.	61
5.3	Metal detector prodder circuit diagram.	61
5.4	Differential magnetometer prodder for precise location of ferrous items.	62

5.5	Differential magnetometer prodder circuit diagram.	63
5.6	Acoustic prodder tips and amplifier.	66
5.7	Mechanism of ultrasound prodder.	67
5.8	Specification of three-axis force measurement prodder system.	71
5.9	Drawing of mechanism of 3-axis force sensing prodder handle.	92
5.10	Photograph of three-axis force sensing prodder and blades	93
5.11	Sample calibration curves for the three-axis force sensing prodder.	93
5.12	Typical sample of prodding force data.	94
5.13	Expanded section of data in figure 5.12 with ‘angle from axial’ data added.	94
5.14	Scattergram of angle of applied force from axial vs. magnitude of force	95
5.15	Percentage of prodding below a certain peak force, vs peak force.	96
5.16	Test rig for measuring penetration of rotary prodders.	97
5.17	Circuit diagram and photograph of shaft encoder interface.	98
5.18	Penetration of “soil A” by rotary prodders, axial force = 5 N.	99
5.19	Block of “Soil A” sectioned to show clean parallel holes produced by rotary prodder.	100
5.20	Contour plots of power required to compress air isothermally and adiabatically.	101
5.21	Specification of rotary prodders field tested in Cambodia.	102
5.22	Rotary prodders field tested in Cambodia.	103
5.23	Detail of tip of sleeved prodder.	103
5.24	General assembly of sleeved prodder.	104
5.25	Block diagram of the prodder control box.	105
5.26	Prototype force sensing training prodders.	106
6.1	Calculation of the ratio of count rate with and without a mine present for given p_D and false alarm rate.	116
6.2	Required ratios of gamma count rates with and without a mine present for given p_D and false alarm rate, vs background count rate.	117
6.3	Spectra of neutrons from ^{252}Cf and $^{241}\text{Am}/\text{Be}$ sources	120
6.4	Effect of different reflectors and filters on thermal neutron flux below surface of soil.	121
6.5	Diagram to illustrate calculation of order of magnitude of nitrogen background.	132

6.6	Variation of radiative capture cross section of Si and N with neutron energy	133
B.1	Neutron-gamma capture cross sections for constituent elements of explosives.	153
C.1	Variation of capture cross section of cadmium with neutron energy. .	159

List of Tables

3.1	Number of papers on different topics, SPIE mines conference, 1999.	30
4.1	Number of mines required in trial for a given minimum probability of detection.	47
4.2	Number of mines, UXO and scrap metal items found in three cleared areas in Cambodia.	51
4.3	Power ratios expressed as decibels (dB).	54
5.1	Force required to detonate some AP mines.	70
6.1	Summary of neutron methods for explosive detection.	109
6.2	Attenuation of thermal neutrons by soil moisture, infinite plane model	129
6.3	Mass of explosive and casing in minimum metal AP mines	140
B.1	Thermal neutron capture and scattering cross sections for some light elements and cadmium	152
C.1	Relative Biological Effectiveness of neutrons according to their energy.	156

Acknowledgements

The writing of this thesis, the research it contains, and especially the field-work, would not have been possible without help from many people.

By name, I would like to mention Terry Thomas (my supervisor) for his consistent help over three and a half years, and the Susannah Cole Trust who gave money for me to live on while writing up after the EPSRC funding had finished.

There are simply too many more people to name everyone: family and friends, academic & technical staff and fellow students at the University of Warwick, staff at the DTW and CDW, mine clearance organisations and individual deminers in four countries. You know who you are; *thank you* to all of you.

Declaration

This thesis, and the research contained herein, are exclusively the work of the author. Publications from the research contained in this thesis are as follows:

Parts of chapter 5 were published as a conference paper [GT98b] and formed the basis of a provisional patent application [GT98a].

Chapter 4 was published as a working paper [GT00a].

The ideas in chapters 3 and 5, with further work on Appropriate Technologies for Demining, formed the basis for two conference papers [GPT97] and [GT99a], and two journal articles [GT99b], and [GT00b]. The former of these was subsequently reprinted with permission in a second journal [GT00c].

Author's note

This electronic version of the thesis was repaired after some accidental data loss from the original files. If there are any outstanding errors please notify the author who will be pleased to correct them. Thank you, Russell Gasser rg@trellick.net

Summary

This thesis examines the technology used for tools and equipment for humanitarian landmine clearance. The main focus is on the removal of mine and unexploded ordnance contamination in the poor, heavily mined countries, particularly Afghanistan and Cambodia.

Initially, the process of humanitarian demining in these countries was examined and described, and the relevant literature reviewed.

Three studies were undertaken with a dual purpose of (a) providing relevant contributions to the science of mine clearance and (b) evaluating some of the methods commonly used in humanitarian demining research.

(i) A statistical analysis of the evaluation of mine detection systems in trials was undertaken. This demonstrated that (a) this statistical analysis is straightforward, and (b) feasible sized trials do not yield useful results from analysis of the crude mine-detection rate. An enhancement to the evaluation process, “Margin of Detection,” was suggested.

(ii) Research into improved “prodders” for detecting mines was undertaken with as much consultation with deminers as possible early in the research cycle. “Sensing prodders” were shown to function technically but not to improve the overall demining process. Measurements showed that many deminers prod in hard soils with sufficient force to detonate some mines; rotary prodders were developed to reduce the force required for excavation, but success in the laboratory could not be duplicated in field conditions. From this work a potentially useful tool for deminer training was developed, which might reduce the risks of accidental detonation.

(iii) The limits of a high-tech detection technique (neutron irradiation and detection of prompt gamma rays) were examined (a) to advance understanding of this method and (b) to demonstrate the feasibility of early evaluation of technologies before extensive research is started. This neutron technology was shown to offer potential benefits to military demining, but to be unlikely to have general application when the higher clearance standards and lower equipment budgets of humanitarian demining were applied.

The thesis ends with conclusions and suggestions for some further work.

Throughout the thesis, the research is focussed on investigating practical problems which deminers have suggested as important constraints on their work.

Chapter 1

Introduction

1.1 The impact of mines

Abandoned land mines have a serious negative impact on some of the poorest countries of the world. Their presence, or even the suspicion of their presence, can disrupt agriculture, commerce and communications, and prevent the return of refugees. The injuries that mines cause are appalling, especially to children — small mines are designed to injure and not to kill. In one of the most affected countries, Cambodia, about 1 in 230 of the adult population is an amputee as a result of injury from mines. The economic consequences of the cost of removing large numbers of people from the active working population, and of medical care, are very serious and affect the post-war recovery of at least a dozen countries.

Mines have been used for many purposes, including: to allow irregular forces to strike effectively against a militarily superior enemy; to protect a camp where irregular forces can sleep; to protect installations and infrastructure from easy attack; to make cross-border infiltration more difficult; and to control a civilian population and sow terror. The military value of their use is increasingly questioned since their main impact is often on civilian populations. All too often, and in contravention of international conventions, mines are placed hastily in unmarked sites then forgotten, with no record kept of their location. However, production and deployment of anti-personnel landmines (APLs) are at last being brought under some control and the number of mines emplaced during conflict can be expected to diminish in coming years. World-wide revulsion at the impact on civilian populations and the development of newer and more mobile forms of warfare by the richer countries have led to many nations ratifying the 1997 Ottawa “Mine Ban” Convention to outlaw common types of APL.

1.2 The need for new technologies

The number of mines already in place has been greatly exaggerated in many reports; an unrealistic figure of over 100 million is frequently quoted. Calculations show that such a large number would take hundreds of years and immense amounts of money to clear. Indeed, the argument was often advanced that the scale of the problem was such that it was insuperable without some technological breakthrough in *detecting* mines. This search for a “silver bullet” ignored several key realities.

1. Even though the current methods of clearing mines have serious limitations in terms of speed, cost and risk they are nonetheless highly effective in clearing land not just of mines but of all explosive debris.
2. Although huge areas still remain to be cleared, the problem is starting to come under control in some countries using only existing technology and large numbers of otherwise unemployed people.
3. Manual demining itself is undergoing rapid improvement through the introduction of better working methods, improved organisation and management, and some incremental improvement and innovation in the design of
 - (i) hand tools
 - (ii) protective equipment and
 - (iii) “pre-clearance technologies” such as mechanised vegetation and trip-wire removal.
4. It seems that high-technology demining solutions coming from research laboratories in Europe and North America to other continents have, thus far, significantly failed to achieve their expected potential.
5. A key problem for deminers in many countries is not an inability to detect buried mines but a need to clear vegetation that may hide tripwires before hand-held detectors can be used. Similarly, an important cause of accidents during mine clearance operations in some countries is accidental detonation during the excavation of mines that have already been successfully located, but are buried in hard soil.
6. Donor aid for demining cannot be expected to last forever, indeed it is already diminishing in some areas. Sustainable demining which is paid for locally cannot use very expensive tools and equipment. Even where these are donated the operating and repair cost may be prohibitive.

1.3 Technology transfer

Humanitarian demining is not unique in encountering problems of adopting and utilising new technologies outside the laboratory. From the technology of the Green Revolution to the current problem of strategies for implementing rural telecommunications in poor countries, development technologies have very often encountered serious problems — both technical and non-technical — in moving from prototypes in the research lab to the finished item in use in the real world. For over thirty years the difficulties of designing in a laboratory far removed from the realities of the end user have been researched and documented in other areas of technology. Many humanitarian demining researchers appear to be unfamiliar with these problems and appear to have focussed on building costly and complex prototypes before fully considering whether such equipment would work in the field, and how local humanitarian deminers would use it.

1.4 Scope of this thesis

A number of factors appear to have contributed to the current situation where research work has not yet led to completely new tools, which are based on new technologies, being widely used in the field by deminers in poor, heavily mined countries. These constraints appear to include:

- (i) An apparent lack of a clear focus on the needs of field practitioners working to clear land in the poor, heavily mined countries — this is not the same as humanitarian demining actions taken by military deminers which appear to be much better appreciated.
- (ii) There seems to be little discussion of the way that innovation in tools and equipment will work as part of the whole complex and varied demining process, as opposed to the relatively small part concerned with locating and indentifying mines/UXO.
- (iii) Insufficient attention appears to have been paid by some researchers to the limited budget available for the purchase and operation of humanitarian demining tools and equipment.

These problems may have come in part from the enthusiasm of engineers and other researchers to find a *technical* solution to the landmine problem; this was maybe a response to seeing the suffering caused by mines. Phrases such as “a human imperative seeking a technical solution” [IEE96] have been used to capture this emotion.

The *environment* of humanitarian demining varies widely — the geophysical surroundings of mined areas, the vegetation, the climate, the cultural background of

deminers, and the types of explosive items to be eliminated can be entirely dissimilar in different countries. Researchers working on the problem may be unfamiliar with some or all of these and thus fail to adequately consider their implications, but technical papers presented by the researchers themselves suggest that landmine detection equipment has very often failed to show promise in the laboratory long before most of these environmental factors come into play at the start of trials in the real world.

Detailed examination of just one or two aspects of the research and design process does not appear to be a promising route to understand such a multi-faceted problem; indeed, a very high degree of technical specialisation seems to be implicated in the lack of tangible results. A wider, inter-disciplinary approach may offer more illumination than a narrower but more detailed investigation, and was thus the method chosen for the work described in this thesis.

1.5 Contents of this thesis

In order to reflect the work undertaken, this thesis does not adopt the standard form of an engineering investigation which would usually be to outline a single well-defined technical problem, study it theoretically and then propose a solution which is verified experimentally.

The work presented in this thesis is organised as follows:

1. *An introduction to humanitarian demining (chapter 2)*. The purpose and history of humanitarian demining are reviewed, and an overview of the common methods and problems of manual demining are given, with explanations of the procedures used. The difference between military demining (breaching) and humanitarian demining (land clearance) is outlined.
2. *A review of the literature on humanitarian demining and especially humanitarian demining research (chapter 3)*. Emphasis is placed on publications relevant to the research undertaken for this thesis on incremental improvement of hand tools.
3. *An analysis of the difficulties of testing humanitarian demining tools and equipment from a statistical viewpoint (chapter 4)*. Without formal methods for evaluating its outcome research cannot be expected to produce optimal results; this possible reason for failure merits investigation. There has been so little published on methods for the statistically meaningful evaluation of tools and equipment for demining, that it might be expected that this is an unusually difficult subject. However, the problem is amenable to standard methods

found in many statistics textbooks and readily understandable without specialist knowledge. Chapter 4 contains such an analysis which is presented both as a contribution to demining research and also to demonstrate that an important aspect of humanitarian demining research appears to have been largely overlooked. The problem of quality assurance after demining is also mentioned in chapter 4.

4. *A practical study of simple incremental improvements to existing tools (chapter 5)*. The most common demining tool, the prodder, was selected and a programme of research into incremental improvements to it started. There were two aims:
 - (i) to make a useful contribution to humanitarian demining by bringing to prototype a better tool, and
 - (ii) to determine if a methodology that incorporated ideas and opinions from field deminers as much as possible from the earliest stages, and used the simplest suitable technologies, did indeed offer better results than the advanced lab-based technologies frequently chosen by researchers.

By incorporating simple sensing technologies into the prodder, deminers could be provided with more information about buried targets as they excavate. A number of proof-of-concept “sensing prodders” were designed and fabricated, and briefly evaluated. It rapidly became clear that unless a way could be found to insert these sensing prodders into medium-hard and hard ground they would be of little use.

Accordingly, a programme of research into low-entry-force rotary prodders was started, and prototypes were developed and field-tested. These were based on the lowest viable levels of technology and cost, to investigate in a practical way a solution potentially useful in the poor, heavily mined countries. In the end the low entry force prodders proved to be unsatisfactory; the work is presented and the negative outcome is analysed in chapter 5 and appendix A.

From the work on low-force prodders it became apparent that many deminers were unaware of the amount of force they used while prodding; a simple low-cost training tool was developed to assist them in developing a feel for different forces.

5. *A case-study of a promising high-tech detection method (chapter 6)*. One of the promising high-technology methods for mine detection was selected for detailed analysis with a view to identifying the precise reasons that it has not yet found application under field conditions; the analysis is presented in chapter 6. The method selected, direct detection of explosives by detecting prompt gamma rays from neutron irradiation of nitrogenous explosive, potentially offers a way of locating concentrations of explosive materials and hence

of distinguishing between scrap metal finds and buried mines. This ability to discriminate between scrap metal and mines could greatly enhance humanitarian demining. Despite the considerable research effort being expended by prestigious companies and institutions on this method, the analysis identifies some fundamental problems which cast serious doubts on the use of neutron techniques in humanitarian demining. These had either not been addressed or had not been published for commercial or other reasons.

The thesis ends with conclusions, and recommendations for further research (chapter 7).

A glossary of demining terms is included after the appendices for reference purposes.

Chapter 2

An overview of humanitarian demining

2.1 Introduction

Humanitarian Demining can be briefly defined as clearing land, physical infrastructure (e.g. roads and irrigation systems) and buildings of all contamination due to explosive items, after the end of a conflict. The purpose is to return the land, infrastructure or buildings in a safe condition to their original owners, to the community or to a new owner.

2.2 A brief history of landmines and demining

The first pressure and trip-wire mines were described in 1726 [Cro98]. Mines were used in the American Civil War, unused specimens from that conflict are still occasionally discovered, and are sometimes found to be basically sound and possibly capable of operation.

The first massive use of mines was in the second World War; Germany laid 35 million mines and the Soviet Union claimed to have laid 67 million. The Germans dominated the design of mines and led the development of the strategic and tactical uses of minefields, but it was the British who excelled in mine clearance. Having entered the war without a metal detector in their equipment, British military engineers quickly adopted in 1942 a design by Kozacki, a Polish refugee. Regularly upgraded up to 1968 it remained in service until 1995. Also in 1942, the first mechanical clearance flail was used by Allied forces in the battle of El Alamein, having been invented separately by two South Africans, du Toit in 1941 and Colman in 1942 [Sti86, page 23]. The principal method of locating mines was, and still is, manual prodding.

After the end of hostilities, the first large scale humanitarian demining operation was conducted between 1945 and 1948 in Europe. Much of the work was done without choice by Prisoners of War; this practice was subsequently outlawed as inhumane by the United Nations in 1949 after the clearance was essentially complete. In 1945 and 1946 between 8% and 18% of deminers were killed or injured depending on the particular clearance programme, though this caused little outcry. About 90 million mines were cleared with an accident rate of about one per 3 300 mines cleared [Cro98].

The clearance rate was generally very fast, largely due to the quality of minefield map-keeping. Rates of nearly 28 000 m² per person per week were recorded in sandy soil in the Netherlands.

The current best estimates of the number of mines in the world are considerably less than the 90 million mines cleared in Europe after the second world war [Bot00]. While civilian casualty rates are horrific with over 20 000 people killed or injured by mines every year ¹, this number is small compared to accidental deaths due to other causes. For example, in Mozambique, a heavily mined country, between 1980 and 1993 mines caused 3% of accidental deaths, suicide accounted for 5% and road traffic accidents 35% [Cro98]. The major cause of death was preventable disease (malaria and dysentery).

Humanitarian demining in its present form emerged in the 1980s after China, the Soviet Union and the USA, amongst others, had supplied many millions of mines to client states during the Cold War. Many of these mines were deployed in proxy wars in Africa and Asia. Humanitarian demining teams were then, and in general still are, trained and managed in the field either by serving military personnel or ex-military personnel with experience in mine warfare and counter-mine measures, explosive ordnance disposal (EOD) and related disciplines. These demining experts generally

¹The direct mine casualty rate is declining and estimates suggest it will be between 10,000 and 16,000 people in 2002. The majority of deaths due to mines are caused indirectly. A typical example is where a village well is mined, or believed to be mined, and villagers prefer to fetch water from the river. As a result children in the village suffer from waterborne diseases and one or more may die each year as a result. These deaths are not usually recorded as deaths due to mines. There are unlikely to be more than two or three mines at most around the well, so carefully walking to the well along the same path every day might lead to fewer deaths than using river water, but would apparently increase the deaths or injuries due to mines if just one person were to suffer an accident. Another example from temperate climates, in a country with cold wet winters, is the farmer who can only use part of the family's land due to mines, or suspected mines. As a result there is insufficient income to pay for warm clothing, and the family has poor nutritional status. The farmhouse was damaged in the war and has windows and part of the roof damaged; repairs are too costly to undertake. A winter chest infection can worsen and eventually lead to severe illness and death. Again, this is in large part due to the mines but will not be recorded as a mine death. RG, August 2002.

had no knowledge of development work, technology sustainability and technology transfer. The demining methods used at the start of modern humanitarian demining were based on the tried and trusted military methods.

Also in the early 1980s a number of NGOs exclusively concerned with humanitarian demining were formed, notably the British organisations the Hazardous Area Life-support Organisation (HALO Trust) and Mines Advisory Group (MAG). The International Committee of the Red Cross (ICRC) responded to the landmine problem in 1996 with an expert report questioning the value of anti-personnel (AP) mines as a military weapon [ICR96].

2.3 Definition of “mine”

Mines are usually defined as victim-initiated devices, but exact definition is difficult as “command detonated mines” are initiated by an observer and not the victim. Some air-dropped devices scattered over a large area can be victim initiated but are technically sub-munitions or bomblets and not mines. For humanitarian deminers the different definitions are not always particularly important since all explosive items must be cleared whatever their type and origin. Mines can be located in and on the ground, and at any height above ground including overhead; trip-wires can be at knee or shoulder height as well as close to the ground.

In addition to mines, items that are usually cleared in humanitarian demining are

- (i) unexploded ordnance (UXO), usually bombs, shells, mortars, grenades and similar items, which have been armed but have failed to detonate
- (ii) unused mines, ordnance, explosives and detonators and
- (iii) Improvised Explosive Devices (IEDs). IEDs vary from simple, home-made explosive devices and Booby Traps to sophisticated and deadly devices designed to make demining itself particularly hazardous. Their presence, or suspected presence, demands exceptional care during demining and can slow clearance work.

Many programmes of high technology demining research have been aimed at locating only buried mines and have not included UXO or IEDs.

2.4 The difference between military and humanitarian demining

The United Nations has proposed a minimum *humanitarian* demining clearance standard of 99.6%, though the organisation has refrained from clarifying whether this is a percentage of land area, of explosive items or of another parameter [Uni98,

section 5.10]. The intent is clear, however, that all reasonable steps must be taken to leave the land without any explosive items at all.

Military minefield breaching is a very different activity from humanitarian demining. The aim is to create a safe lane, often about eight meters wide, in a mined area to allow the passage of troops and materiel. Breaching is frequently done at night to try to avoid detection, and it may be done under enemy fire. Military deminers are usually highly trained and well equipped specialists, and they work as fast as possible. Taking the risk of overlooking a small number of mines may at times be acceptable in return for faster breaching. Explosive items are usually removed and put to one side. Breaching can be done mechanically with mine-ploughs, mine rollers or other tools fitted to large tracked vehicles, and by explosive methods.

Between humanitarian land clearance and military breaching lie a range of activities usually undertaken by serving military (or specially contracted ex-military specialists) acting in a peace-keeping role, frequently military personnel seconded to a United Nations force. These are commonly called humanitarian demining but differ greatly from land clearance done by local people.

Such tasks range from clearance of essential access roads and infrastructure immediately, or soon, after conflict has ceased, to peace-keeping activities such as daily verification of roads in the event of factions re-mining at night. In terms of the available resources, the personnel, and the access to technology, these activities are generally closer to military demining than locally based humanitarian demining in the poor, heavily-mined countries.

One task common to military and humanitarian deminers is EOD, dealing with the threat posed by explosive items such as shells and mortars of large calibre (typically greater than 60 or 80 mm), large air-dropped bombs, and caches of explosive items. This activity is commonly called “Bomb Disposal” and requires far more training than simple demining, but offers more varied and interesting work. Demining organisations that have teams of local deminers clearing land generally have a small number of specialist EOD teams in support. In some areas, for example parts of Laos and Vietnam, “demining” is completely, or almost completely, EOD as the contamination is due to air-dropped ordnance with few or no mines.

2.5 Mine clearance strategies

There are essentially two strategies which can be pursued to clear land contaminated with explosive debris. The first is to mechanically treat all the land to a suitable depth by grinding, milling or flailing in order to detonate or render in-serviceable any explosive items. The second strategy is to attempt to carefully locate each explosive

item and then either blow it up or burn it in situ, or render it safe and remove it for dismantling or disposal elsewhere.

These two strategies are not entirely mutually exclusive, mechanical ground clearance can precede localisation of any remaining individual items [Joy98a] and some experts have proposed a strategy of locating any large mines/UXO before mechanical clearance to reduce the risk of major damage to machinery [CMA99].

Mechanical clearance, the first strategy, is currently highly controversial in the demining community. There is a fierce debate about the safety of explosive items rendered in-serviceable, about the possibility of mines being thrown by the machine into a cleared area and other important issues. Mechanical flails (or mulchers) are, however, becoming more widely used for clearing vegetation and trip-wires to speed up and make safer subsequent manual clearance. This is commonly known as Mechanically Aided Manual demining [Men00] (see also section 2.6.1).

2.6 Surveying mined areas

Before clearance can start a mined area needs to be defined, mapped and marked out on the ground. If all mines were put down in a precise text-book pattern with warning signs all around, and all the information about the limits of the mined area carefully recorded and the records available (as are now required by international conventions) then clearing the contaminated areas could begin immediately. In reality, and especially where mines have been used for terrorist purposes to control a population or by small, irregular and highly mobile groups, there are no records. In some areas mines are laid apparently at random, figure 2.1 shows an aerial map of a mined part of Croatia with known mines/UXO marked; the distribution appears to be largely random and unpredictable with mines laid in open fields as well as near buildings and strategic features. Defining the limits of the “mined area” and knowing where to begin and end clearance activity is obviously very difficult.

2.6.1 The different “levels” of survey

Level One survey

Local people will often know roughly where mines are and may even be able to precisely locate and identify some of them. Mines are sometimes located by animals that are killed by stepping on them. A knowledge of strategy and tactics may also indicate likely sites for mining. Large UXO may be well known and even used as a local landmark. Documenting this information is known as Level One

survey and provides a preliminary map of mined areas and suspected mined areas without the surveyors knowingly leaving safe areas. Computer based mapping and Geographical Information Systems (GIS) started to be used for this in the mid 1990s. The definition of Level One or General survey used by the United Nations is as follows [UNM99b]:

“The objective of a Level One: General Survey is to collect information on the general locations of suspected or mined areas. Information must be collected about the areas affected by mines or UXO and areas that are not affected. Areas must be categorised and the reliability and credibility of data recorded. [...]”

Level One survey can also provide important information as to the socio-economic impact of mines/UXO in a particular area. This information can be vital to planning mine clearance and obtaining funds from donor agencies to pay for it.

Level Two survey

There are different definitions in use by different organisations as to what constitutes exactly which level of surveying, but Level Two survey is generally taken as precisely defining and accurately marking the mined area [Kee99]. The definition used by the United Nations is [UNM99b]:

“The objective of a Level Two: Technical Survey is to determine and delineate the perimeter of mined locations initially identified by a Level One: General Survey. The marked perimeter forms the area for future mine clearance operations. The Level Two survey requires trained and properly equipped mine clearance personnel with the necessary skills to undertake and accurately record the survey work. Where possible, with time and resources permitting, these teams should also undertake area reduction work in order to accurately define the outer perimeters of the minefield.”

The Survey teams work from a clear area until mines/UXO are found and then use the mine locations, plus a safety margin, to define, map and mark a mined area. A perimeter safe lane one or two meters wide is usually manually cleared. Level Two survey, sometimes referred to as ‘Area Reduction’, can be a high-risk activity depending on the conditions. At the end of Level Two survey there should be clear boundaries between what is mined and what is not. If the ground is free from vegetation and not steeply sloping the job is relatively easy. However, in tropical countries where vegetation grows rapidly and local people have not ventured into the area for many years because they suspect it is mined, the surveyor may find an impenetrable jungle, with dense bamboo thickets, steeply sided ravines or other hazards. Undergrowth cannot be cut back quickly to make a path due to the possible presence of trip-wires or mines; figure 2.2 shows photographs of two overgrown mined areas. In areas with a low density of mines and UXO that are not in a pattern (as



Figure 2.2: **Overgrown mined areas in Cambodia.** The heavy vegetation and old trench system – which may well contain explosive debris – in the lower photo are typical obstacles faced during demining. In both photos the area in the foreground cleared of vegetation and mines was previously like the uncleared background. Note also the marking system used to indicate the limits of the cleared areas: wooden stakes and plastic tape.



Figure 2.3: **Vegetation clearance using a flail on a long boom on an armoured tractor.** Note: tractor and cab are heavily armoured on right-hand side only. From CD-ROM catalogue of demining equipment [M⁺99].

illustrated in figure 2.1), level two survey would require almost the same amount of work as a full clearance operation. Such areas are commonly found in Bosnia and Croatia. With current methods and technology a separate level two survey before clearance is not feasible in this type of very low density mined area and full clearance follows level one survey.

Accurately defining and marking the limits of a mined area is the quickest way of returning land to the community. In the extreme case where land has to be used immediately to avoid suffering (e.g. due to hunger), local people sometimes carry on agriculture and transport activities by working close to identified mines/UXO. Any cost-effective practical improvement to Level Two survey in difficult areas offers potentially very large rewards immediately. However, permanently marking mined areas is surprisingly difficult; in poor countries marking materials are very often stolen to be used for other purposes and in former Yugoslavia there have been reports of tourists stealing mine warning signs as souvenirs. In order to mark mined areas so that they can return later to clear them, demining organisations rely on methods such as burying a steel bar at a point identified from GPS coordinates or compass bearings to fixed landmarks like hill-tops, buildings, or wells. On subsequent visits the steel can be precisely located with a standard metal detector.



Figure 2.4: **Tempest remote-control mini-flail with custom built blast resistant hull.**

Two important technical developments have been pursued by in-the-field deminers to improve Level Two survey are

- (i) the use of dogs to sniff out mines, including the use of air sampling techniques with dogs in kennels to sniff the samples, such as the Mechem MEDDS system [Joy98b]. In the future field-portable vapour detection technologies may have enough sensitivity to become useful in this role. Ion Mobility Spectrometers (IMS) are one such technology, its developers include the Sandia National Labs in the USA [Woo97]; the novel fluorescence methods developed by Nomadics Inc are another [Inc00].
- (ii) the use of flails for vegetation and trip wire clearance. Flails range from standard vegetation mulchers mounted on long boom-arms on armoured tractors or blast-resistant vehicles to purpose-designed remote-controlled blast-resistant mini-flails such as those described in [LvH98] and [Goo99a]. Figures 2.3 and 2.4 show photographs of this type of equipment.

2.7 Humanitarian demining methodology

Manual clearance operations are painstakingly slow. A set of detailed instructions or Standing Operating Procedures (SOPs) must be followed at all times to ensure safe working; all deminers in an area must work in exactly the same way when clearing and when marking cleared areas.

Deminers generally work in work group of two or three known by the established military name of “breaching party.” One or two deminers are active and the other resting or observing. A team or platoon usually consists of 10 or 12 breaching parties.

Lanes are marked entering the mined area from the cleared perimeter lane. To reduce the risk from an explosion accidentally caused by another deminer a typical spacing between active lanes is 10 to 25 metres. Lanes are usually one metre wide and are marked as they are cleared with plastic tape on wooden stakes, painted rocks or similar markings.

The exact clearance method used depends on the circumstances and the demining organisation, but it is common for the deminer to have a light wooden stick placed on the ground across the lane at the limit of the cleared area. This is the baseline and the deminer is always behind it but clearing the area in front of it. Figures 2.5 to 2.7 show photographs of deminers demonstrating the sequence of activities. The first action is to probe carefully for trip-wires by feeling carefully from ground level (or as close to the ground as is permitted by the vegetation) to overhead with a bamboo or wire wand. Vegetation is then cut back for as far as the deminer can safely reach forwards over the baseline, about half a metre. This is a painstaking operation that in some countries takes up to two-thirds of the total time of demining. Because of the risk of hidden trip-wires careful cutting with hand tools is required and all cut items are gathered as they are cut so that they do not fall on top of a trip-wire or hidden mine.

Once the lane has been cleared of vegetation as far as the deminer can reach, the newly cleared area, typically one metre wide and about half a metre forwards from the baseline, is usually checked again for trip-wires from ground level to overhead with a bamboo or wire wand. A metal detector is then used to identify any buried or surface metal items, and their location marked with a lightweight non-metal marker. Before each use the metal detector is checked by passing it over a known test-piece — a small metal target embedded in a plastic holder — to ensure that it is working correctly.

Starting at a safe distance, often about 200 mm back from the marker, the deminer prods and excavates towards where the metal detector indicated a target. The



Figure 2.5: **Sequence of operations, manual demining in Cambodia (part 1).** — deminers demonstrating SOPs in a prepared safe area.

Above: Tripwire detection using a bamboo wand

Below: Vegetation cutting and removal.



Figure 2.6: **Sequence of operations, manual demining in Cambodia (part 2)** — deminers demonstrating SOPs in a prepared safe area.

Left: Metal detecting.

Right: Marking location of metal find.

prodder is kept at a shallow angle, less than 30 degrees from horizontal, in order to contact the inert side of the mine first and not the pressure plate on top. Mines that have moved or were deliberately planted on their sides present a special danger. The deminer works forward and down, clearing the ground until a target is identified. If a mine is found, as soon as enough of it is visible to permit identification the deminer calls for a supervisor and withdraws. The supervisor will excavate just enough to be able to place a block of explosive to destroy the mine; detonation is usually done at the end of the day's work (see figure 2.8). More usually the deminer will find a small piece of metal. If nothing is found the area is re-checked with the metal detector and excavation continued until there is no longer metal indicated. Small rusty steel items can be very difficult to find and there may be no more than a few flakes of rust causing the false alarm. In many areas up to a thousand false alarms are found for every mine, in some areas an individual deminer can expect to find an explosive item only every three or four months; this can lead to boredom and carelessness. The author met one deminer in Cambodia who stated he had never yet found a live



Figure 2.7: **Sequence of operations, manual demining in Cambodia (part 3)**

— deminers demonstrating SOPs in a prepared safe area.

Excavating metal find.

[Note that deminer is working in a one-metre wide lane with a stick placed across the end of the lane as baseline. Deminer is behind baseline (with both hands well back from point being excavated); the area being cleared is in front of the baseline.]

target in four years work. Figure 2.9 shows close up photographs of excavation and prodding being carried out in hard, dry ground in Cambodia.

In areas without vegetation SOPs may be substantially different. For example, in Afghanistan dogs are widely used for survey work. Figures 2.10 and 2.11 show photographs of mine clearance using dogs near Kabul. Two dogs are used separately to cover each piece of ground twice in a systematic manner. The dogs walk forwards in a straight line on an eight metre long leash and then return to their handler, sniffing the ground in both directions. The handler then moves sideways about two meters along the baseline and repeats the search. The dogs are trained to sit if they smell explosive vapour; the success of dogs depends very much on a close relationship between the dog and the dog-handler. All areas where a mine-dog indicates the presence of explosive vapour are searched with a metal detector and all metal finds are excavated carefully.

Most SOPs have historically insisted that the deminer should work prone while excavating suspicious objects, but in reality many deminers prefer to work squatting



Figure 2.8: **Elimination of small UXO by blast-in-situ.** .

Above: Small UXO (a rocket which has failed to detonate) has a block of explosive wrapped in detonation cord placed next to it.

Below: At the end of the working day a slow-burn fuse is used to fire the detonation cord setting off the explosive and destroying the UXO.



Figure 2.9: **Prodding and excavation in hard dry soil in Cambodia.** Gradual uncovering towards a target by prodding to a limited depth, then removing soil with a trowel and a paintbrush.



Figure 2.10: **Sequence of operations, clearance using dogs in Afghanistan (part 1).**

Above: Searching with a trained mine-dog on an eight-metre leash in a live area in Afghanistan. Note marking of clear and live areas using white and red painted stones.

Below: Mine dog is trained to sit when explosive vapour is sniffed. Dog handler kneels, raises one arm, and shouts “Mine!”.



Figure 2.11: **Sequence of operations, clearance using dogs in Afghanistan (part 2).**

Above: Area indicated by mine dog as having explosive vapour is searched with a metal detector.

Below: All metal finds are carefully excavated.



Figure 2.12: **Deminer being trained to new SOPs which permit working in a squatting position.** Note the one-metre wide lane, stick to indicate baseline, and that the deminer has both hands behind baseline while prodding/excavating.

or kneeling [Smi00b]. There is a trend towards permitting this position, and some demining organisations are testing blast aprons which protect the legs and genitals while squatting or kneeling. Figure 5.8.1 shows a deminer in a training area working to new SOPs for single-person breaching parties using a squatting position. If the deminer is wearing a protective visor and blast-resistant protective clothing recent evidence suggests they will probably survive accidental detonation of a small blast mine, they may even walk away unharmed [Smi00c]. However, blast patterns and tools and soil conditions vary widely, and hence the injuries caused by detonation are also very variable; there are reliable accounts of deminers with no protective equipment surviving blast mine explosions in Afghanistan with little or no injury, especially when using a long-handled trenching tool to excavate. Trip-wire fragmentation mines, and bounding mines that detonate after leaping into the air are much more hazardous and can have a kill radius of 100 metres or more; a kill radius of 200 m has been quoted for the PROM-1 mine. Figure 2.13 shows photographs of some common types of antipersonnel mines.



Figure 2.13: **Antipersonnel mines.**

Above: Blast mines with a low metal content. Triggered by downward force on the pressure plate or on the casing of the mine.

Below left: Antipersonnel fragmentation mines with metal cases that form shrapnel when the mine is detonated. Usually initiated by tripwires

Below right: Antipersonnel bounding mines which contain shrapnel. Usually initiated by tripwires these launch into the air before exploding; they have large kill radii and are highly dangerous.

2.8 Safety

The keys to safety appear to be the correct following of good SOPs by well-trained staff using well-designed tools [Smi00b]. Supervisors have the responsibility of insisting on compliance in detail no matter how trivial the deviation from correct procedure seems; standards of enforcement appear to vary greatly from one demining organisation to another. The causes of accidents also vary according to the exact conditions (for example vegetation, soil type, equipment used, and training), but the two most important causes of accidents in countries where data are available are (i) accidental detonation during excavation, and (ii) stepping on a mine that has been missed during clearance [Smi00c]. Despite popular perceptions, demining and EOD are not particularly hazardous tasks if carried out properly. Indeed, they are eagerly sought after job opportunities in many heavily mined countries.

2.9 Summary

It can be seen that humanitarian demining is quite distinct from military breaching, though the influence of military and ex-military deminers is very strong throughout humanitarian demining organisations. Most of the equipment currently used for humanitarian demining has its origins in military demining during and after the second World War. The skill level required of local humanitarian deminers is relatively modest, obviously patience and rigorous attention to detail are highly desirable personal qualities.

In recent years demining has become both cheaper and safer, largely due to improvements in management and working practices. Overall it is not a particularly hazardous job, especially when compared to industrial and road traffic accident rates in many heavily mined poor countries.

Chapter 3

Defining the problem — a review of the literature.

3.1 Introduction

Recent estimates by Trevelyan suggest that perhaps £190 million is being spent annually on humanitarian demining research projects [Tre00d]. However, as has been stated in the introduction to this thesis, it seems that the largest research programmes have to date had little or no practical impact on the equipment used by local humanitarian deminers in the most heavily mined countries [GT99a, GT99b]. Furthermore, there appear to be very few published analyses of the reasons for this lack of practical results in the field in the short term.

3.1.1 The dominance of buried mine detection in research

Humanitarian demining has to meet a number of very specific requirements, both technical and non-technical. One particular technical requirement, that of detecting buried mines, has attracted much attention and research funding. To date there have been few research results in this area that have been successfully translated into completely new items of practical equipment for local deminers in poor countries and the detection methods in regular use by local humanitarian deminers are still the metal detector and prodder. However, metal detectors have improved considerably over recent years as a result of research and are now capable of finding most minimum metal mines, even when buried in soils with a high ferritic content [Min99a]. This research on metal detectors has, in general, been undertaken commercially by the relatively small companies which manufacture the equipment and has not formed a significant part of the large government-level expenditure on humanitarian demining research.

The detection of abandoned and hidden mines is only one small part of a much larger process of clearing land. Other crucial parts of the process appear to have been largely ignored in the past by scientists in advanced research laboratories, though recent personal contacts by the authors suggest that there may now have been some significant changes. At least one major research laboratory (DERA Malvern, UK) has recently sent technical staff to visit mined areas before choosing technologies for development [Kee00].

As was outlined in chapter 2, improvements to the process of surveying suspected mined areas offer potentially very significant advances — for example if suspected areas can be declared free from mine/UXO contamination with sufficient confidence they can be returned to the community immediately. Research into improved survey methods has often looked at high-tech methods of defining and mapping mined areas from satellite imaging or airborne reconnaissance, neither of which has been successful at identifying mines [DY99]. The mine clearance organisation ITC has enjoyed some success in identifying areas which local people believe to be mined in Mozambique by remote sensing; the difference in the vegetation on cultivated land and on abandoned land can be mapped from the air or from satellites. Given the high probability of vegetation cover on suspected mined areas, which are usually not farmed due to the risk of mines (see figure 2.2), remote sensing from the air would not appear a promising approach for the location of individual mines. Other technologies that, until now, have improved survey methods have generally been imported from other fields and include global satellite positioning systems (GPS), geographical information systems (GIS) and computer based map generation methods [GIC00].

Another survey technology that has received little attention by researchers is how to mark and fence mined areas [UNM99a]; some heavily mined countries are so poor that even painted stones may be stolen to use as adornments. Any material that can be taken and used is likely to disappear, so signs and barriers erected to warn local people of a mined area cannot be expected to last very long. As mentioned in chapter 2, there are reports from former Yugoslavia of minefield marking signs being taken by foreign tourists as souvenirs.

3.2 “The view from the field” and “The view from the lab”

An attempt to produce a consensus on deminer requirements was led by Craib in the mid-1990s; this mentioned factors important to deminers in the field though it focussed on detection as the primary problem [Cra96]. Since then, experienced deminers such as Keeley and King have regularly presented reminders of the true

nature of the humanitarian demining problem [Kee96, Kin97, Kin98a]; these appear to have been largely ignored by researchers working on mine-detection methods. These deminers also highlighted the potentially large advantage of improving survey methods and technologies (see also previous section).

The view from the field and the view from the research lab appear to have remained poles apart [Kin97, GT99a], though a few of the smaller research funders have aligned themselves closely with the deminers in the field. Typical of these is Mines Action Canada who published a useful introductory statement for researchers [Min99b]. The largest annual learned society conference on demining, whose proceedings form a significant part of the published-on-paper literature on mine detection, is organised by the SPIE (The International Optical Society), under the title “Detection and Remediation Technologies for Mines and Minelike Targets”. An analysis of the 1999 conference [D⁺99] clearly reveals research foci at the time; of the 120 papers presented just four covered aspects of how human deminers work, in a session entitled “Human Cognitive Processing”. Table 3.1 gives some details of the 1999 SPIE conference papers; most of the proposed detection methods used advanced electronics and powerful computers. There were no papers

Topic	Number of papers
Chemical and biological sensors and “sniffers”	21
Ground penetrating radar	21
Sonar	19
Imaging (infra-red, visible and hyperspectral)	18
Magnetic and electromagnetic (metal detection)	13
Acoustic methods	10
Sensor fusion by data processing	10
Positrons and nuclear quadrupole resonance	4
Human cognitive processing	4

Table 3.1: Number of papers on different topics at the SPIE mines conference, 1999.

on the technologies that humanitarian deminers have suggested as overcoming the principal obstacles to clearing mines rapidly and safely using existing methods, such as: mechanised vegetation clearance, improved trip-wire detection, faster and safer excavation of hard soils, improved quality control methods, scratch resistant safety visors, protective clothing (personal armour) which is more comfortable in tropical heat, improved reliability of electronic equipment such as metal detectors, and vehicles which can evacuate injured personnel from remote areas that may be water-logged or otherwise inaccessible. Trevelyan subsequently published the results of a

systematic survey of deminers' priorities funded by the US Army Night Vision and Electronic Sensor Directorate [Tre00d]. This reinforced the earlier anecdotal 'list of requirements' and introduced a few unexpected new items such as the need for supplies of good-quality drinking water for deminers in hot climates. Overall, Trevelyan commented: "Many of the technology needs can be satisfied with equipment which is available now, often at modest cost. Donor institutions could significantly increase the effectiveness of the resources they provide now by ensuring that these needs are satisfied."

3.3 Technologies for demining

Several comprehensive reviews of the technologies that have been suggested for demining have been published, e.g. [BG97]. The authors of this review also maintain a regularly updated internet website of references covering all aspects of humanitarian demining including the currently researched technologies [BG00]. Another website with brief descriptions of many technologies is maintained on the same server at the *École Polytechnique Fédérale* in Lausanne [M95]. Bruschini has also worked with others in producing the EUDEM database, a study on the state of the art of demining technology and research in the EU [BBSC99].

The Humanitarian Demining Center of the US Military presents on its internet website details of many technologies which have been demonstrated as proof-of-concept models or prototypes [NVE00]. Further internet accessible websites with large amounts of humanitarian demining information include those of (i) The Mine Action Information Center at James Madison University [MAI00], (ii) the University of Western Australia Department of Mechanical Engineering [UWA00], (iii) the United Nations [Uni00], and (iv) the Geneva International Centre for Humanitarian Demining [GIC00]. The Lawrence Livermore National Laboratory in the USA has a large landmine bibliography [LLN99a] and a landmine Who's Who [LLN99b] including military, academic and commercial organisations.

Conference proceedings and internet websites are the two main sources of humanitarian demining research information. Only one international journal is dedicated to the topic, the *Journal of Mine Action* which is published both on paper and on an internet website by the Mine Action Information Center [Min] (see above). This journal covers all aspects of demining from field reports to technology research.

Overall, substantially unequal amounts of information have been published on research into different demining technologies. Papers on ground penetrating radar (GPR) have been common in the literature in recent years, especially in the proceedings of technical conferences. Most of the publications on GPR refer to theoretical

or laboratory work. Reports of field trials of GPR equipment are much less common and so far the results appear somewhat disappointing, for example the reports of a series of field trials in Cambodia [BN98].

3.4 Literature covered elsewhere in the thesis

The explosive detection technology chosen for further consideration in this thesis, neutron irradiation, has an extensive published literature. This is reviewed in the appropriate chapter later in this thesis, chapter 6.

3.5 Prodding

Prodding has received little attention as a technique worthy of investigation and improvement. Indeed, many of the references to prodding refer to the need to replace it, such as “We need to intensify research into better methods of demining... the most common tool we have now for detecting landmines is still a stick attached to a person’s arm.” [Ind97, chapter IV].

3.5.1 Mechanised prodding

Several schemes for automating the prodding process have been presented, for example [AR96, DHW97, ABHS99], but no field trials of equipment have been reported. This work has overlooked the contribution of the human operator to the prodding process. Chapter 5 of this thesis argues that

- (i) the remarkable abilities of the human who holds the prodder and
- (ii) the efficiency of combining the prodding with the subsequent excavation and uncovering,

are two of the main advantages of the technique. Trevelyan has suggested that robots in general have no application at present in the problem of demining [Tre97].

Smith has put forward criteria for improving the safety and effectiveness of prodders [Smi99], and Trevelyan and others at the University of Western Australia, together with the HARC demining research centre in Pakistan, have worked on several aspects of prodding tools. These include controlling the maximum force used during prodding [Tre00a], safety and local production of better and cheaper prodders [Tre00b].

Several different types of ‘improved prodders’ have been marketed as commercial products. Among these are:

1. Prodders of exotic materials for military use. Non-magnetic materials such as aluminium alloys, stainless steel, fibreglass and titanium have been used for prodder shafts. Telescopic prodders that can be easily folded for carrying have been made, as have ones with pistol-grip and other handles that allow the deminer to push harder. Typical examples are given in [AB 98, Mis98].
2. Prodders suitable for local manufacture in heavily mined countries at low cost. They can be specifically tailored to the type of ground found locally and the raw materials and manufacturing skills available. In addition to being safe and effective, these prodders are more affordable for local deminers [Smi00a].
3. One design of advanced sensing prodder has been marketed. The DEW prodder [DEW00] uses ultrasonic technology to determine whether the prodder tip is in contact with rock, plant roots or plastic. Initially this seems to offer some important advantages, but on closer examination it is more useful for military demining where speed is of the essence than for humanitarian land clearance. Many humanitarian deminers on encountering a rock would still decide to excavate and remove it to ensure that the target is not a mine with a rock immediately above (or alongside) the pressure plate. This is discussed further in chapter 5 and appendix A.

3.5.2 Acoustic prodders

To enhance the discrimination between mines and inert objects, skilled deminers sometimes listen carefully to any sound made by the prodder or excavating tool. At times, some deminers will place their ear close to the end of the prodder to try to capture a faint difference in timbre that distinguishes contact with plastic and metal from roots and rocks.

A few authors have reported work with acoustic sensing prodders. Horowitz and Wolff designed a prodder with a single piezoelectric transducer at the tip which first stimulated the suspected mine with a rapid impulse and then captured the resulting resonances for computer analysis [HW99]. Antonic used a microphone at the upper end of the prodder and proposed computer analysis of the waveforms [Ant97]. Both of these approaches suffered from significantly less than 100% success in mine identification. The author used both miniature microphones and piezoelectric elements mounted in the tips of prodders; the resulting signals were amplified and the deminer could listen with either an earpiece or a small loudspeaker. Human hearing offers a powerful discrimination method. This work is reported in chapter 5.

Even though these simple acoustic prodders increase the information available to the deminer they probably add little to the overall demining process and were generally

not considered as worthwhile by deminers who commented on the concept (chapter 5 and appendix A).

3.5.3 Easy entry or Low force prodders

One of the simplest effective improvements to prodders was reported by Levy. His students found that oval cross-section prodders could be used to reduce the force required to penetrate soft and medium ground by about half, compared to a circular cross-section prodder [Lev99].

There appears to be no work published on prodders using more complex or advanced technologies specifically designed to reduce the force required to penetrate hard ground. This problem has been addressed by

- (i) teaching deminers how to prod and not by providing them with special tools,
- (ii) softening the ground, usually by watering hard dry ground [Lar99] and
- (iii) various attempts to mechanise prodding and remove the human operator to a safe location (see section 3.5.1 above).

3.6 Equipment development: areas without a formal literature

3.6.1 Vegetation Clearance - an essential precursor to location

Deminers in some countries, for example Cambodia, spend up to two-thirds of their time clearing vegetation, yet this problem has failed to attract much research interest. Trevelyan has proposed investigating abrasive loaded water jets for this purpose [Tre00c] as they have already successfully been used for cutting open mines and UXO [Mit00]. However, vegetation clearance has been addressed with considerable success by deminers themselves developing machinery based on agricultural and other commercially available equipment. Some specialist blast-resistant vehicles have also been developed for vegetation flails, e.g. the Tempest [Goo99a]. The lack of research literature on these ‘pragmatic solutions’ has several causes including:

- (i) most of these successes having come from development based on field experience and not on formal research and
- (ii) normal commercial confidentiality by companies with an interest in manufacturing these products.

3.6.2 Other technologies lacking a formal literature

Mechanised vegetation clearance is just one example of an area where significant progress has been made in demining technologies, but which lack a formal research literature.

Reviews and reports have been published of the use of mine dogs and of trials of their abilities, e.g. [BRT99], but these do not cover detailed working practices or comparisons made with rigorous methodology. The local production of improved tools and personal protective equipment (PPE) has also been reported on the basis of results without full research details, e.g. [Goo99b]. Similarly there have been several reports on tools, headgear and ballistic clothing [UWA00].

The German Federal Foreign Office, together with the United Nations Mine Action Service and a German humanitarian demining NGO, Menschen gegen Minen (MgM), have produced a catalogue of demining equipment on CD-ROM [M⁺99]; although this is not a formal contribution to the literature it fills a need to disseminate the results of the ground-breaking work of many demining organisations in developing and adapting appropriate technologies that are otherwise unreported. The BRTRC website [NVE00] also has details of several pieces of equipment developed directly by deminers.

The internet list-server network@MgM.org [Men97] has served as a forum for the discussion of these topics, the dissemination of ideas, analysis and criticism; at times it has been polemical.

3.7 The statistical analysis of test results

The results of field-testing mine detectors have been presented in a variety of ways, but almost without exception no attempt has been made to support the results with an analysis of their statistical significance.

Typically, figures for “detection rate” and “false alarm rate” have been plotted on a graph, sometimes with projections of expected performance of a technology as it is developed, for example [AL96, page 174].

Perhaps the only paper of note on the statistical analysis of the probability of detection was that of Voles [Vol98]. This dealt with the case of the failure to find zero or one mine during a trial though it contained assumptions that appear invalid. Chapter 4 of this thesis presents a rigorous analysis that does not rely on the same assumptions, which was subsequently published as a working paper for discussion [GT00a]. Voles in the meantime had reviewed his earlier work and will be

publishing an amended analysis shortly [Vol00]. All of this work shows clearly that (i) data for the probability of detection is meaningless without an accompanying level of confidence and (ii) the required probability of detection cannot be verified from simple mine detector trials of feasible sizes.

3.8 Optimising demining research

Some comparative analyses of different mine detection technologies have been published, e.g. [Jan96], but these do not appear to include work on assessing the potential usefulness of techniques at an early stage in order to optimise the time, effort and money spent on humanitarian demining research. One of the few references to this critical assessment was by Brooks and Nicoud who presented a decision flowchart and suggested the need for early evaluation of demining technologies in a paper reporting field trials of a ground penetrating radar (GPR) system [BN98].

At present it seems that work is being done on a large number of technologies in the hope that at least one of them will function as required. The advantages (and sometimes the disadvantages) of different technologies are mentioned in many reports of research, but systematic approaches to compare technologies, using methods based on demining criteria, have apparently not been developed. Several of the mine detection methods currently receiving large-scale funding may have theoretical limits which almost certainly prevent their use in humanitarian land clearance. For example, chapter 6 of this thesis analyses simple neutron-gamma (prompt gamma) methods and finds them unsuitable for locating small buried mines.

3.8.1 Ground penetrating radar (GPR) as an example of research

The large amount of interest in ground penetrating radar over the last decade is an example of how research has been pursued very much on an ad hoc basis, albeit with very generous funding. Numerous institutions have undertaken research on GPR, but overall coordination of the various approaches has not been widespread. The desirability of such coordination has been commented on in general terms by Janson [Jan96, page 15].

GPR initially received a lot of attention when it proved capable of locating the “plastic mines” that had been laid on the Falkland Islands [Chi96]. Despite the impression given, the types of mine used in the Falklands were minimum-metal mines, not zero-metal mines, and the initial success of GPR may have been in part due to the type of ground and the short grass cover. GPR has, to date, still failed

to demonstrate general usefulness and an adequate ability to discriminate between buried mines and objects such as rocks, in field testing. This problem of feature extraction has been addressed by many researchers by designing increasingly complex computer-based signal processing systems, e.g. [LF98]. There appears to be no published analysis which demonstrates that radar by itself will be able to theoretically achieve the UN 99.6%, or a similar humanitarian demining detection criterion except under particular ground conditions which are relatively uncommon. Even for military purposes its use is now being questioned at the highest level; in June 1999 the US Marine Corps stated “To date, the GPR technology has not indicated the potential to meet the Advanced Mine Detection system requirements” [US 99].

The author has been unable to find any substantial published work which demonstrates, on a theoretical basis, that high technology mine detection methods currently receiving large-scale funding have the potential to theoretically meet the “99.6%” criterion.

The lack of professional journals dedicated to research on mine clearance, and the need for secrecy in both military and commercial research may contribute to limiting publication of some demining research information.

3.9 Summary

A review of the available literature shows that although there are numerous scientific publications on some aspects of demining research (especially mine detection using GPR and other advanced technologies), there also appear to be important areas which have few publications of note. These areas include:

1. analyses of the ability of technologies to approach or exceed the humanitarian demining criterion of finding 99.6% of all mines,
2. rigorous statistical analyses of the results of testing mine detection systems and quality assurance methods,
3. reports of field testing mine clearance tools and equipment.

Deminers have drawn the attention of researchers to the reality of humanitarian demining in poor countries in a number of publications and outlined some of their requirements.

The lack of an academic journal specifically dedicated to humanitarian demining research (as opposed to proceedings of learned conferences) may have influenced the number of publications on some topics. There is, however, an increasing body

of informal reports, discussion and 'catalogue' style reviews of demining tools and equipment.

Chapter 4

The problem of evaluating the performance of mine detection systems

4.1 Introduction

The lack of published statistical work on the evaluation of mine detection systems was noted in section 3.7. This chapter has two main aims:

1. To present such an analysis as a contribution to improving the evaluation of demining systems and equipment.
2. To demonstrate that such an analysis does not depend on statistical methods which are either unusual or particularly difficult — all the work here is based on well-known quality control methods to be found in many textbooks. The lack of publications about, and application of, such methods by demining researchers can thus be attributed more to a misunderstanding of the need for this statistical rigour, or difficulty in accepting the consequences of its application, than to any problems with its implementation.

Even in densely mined areas mines tend to be widely separated, and very few mines will remain undetected by a good mine detector system. Objective analysis of the performance of mine detectors based solely on the percentage of mines not detected is thus difficult at more than an anecdotal level. Field conditions, the types of target and operating procedures vary so widely that testing in a laboratory or a designated test area may not reveal the limits of the performance of a mine detector in a specific mined area with a particular type of mine/UXO contamination. Generalisations

about humanitarian demining equipment performance can have only a very limited validity.

Reports of promising technologies of necessity quote results such as a “95% success rate” or “16 out of 16 targets found” [Ano00] but usually do not attempt to present an analysis of the statistical confidence of such data. This chapter examines the difficulties in assessing the performance of mine detecting equipment both quantitatively, by developing a statistical analysis and presenting the results, and qualitatively, by analysing the practical difficulties of evaluating equipment performance specific to demining. Use of the concept of “margin of detection” is proposed as a possible way forward.

4.2 The three main problems in testing demining equipment

The three principal difficulties in assessing prototype demining equipment are:

1. Testing equipment that is still under development — and hence not yet capable of finding every mine — in live areas is not possible because of the risk to the operator. Testing under simulated conditions does not yield the same results; the major impediments to finding mines, such as vegetation, have to be removed or altered to place surrogate mines. Deminers, no matter how carefully they seek to re-create their working practices, are likely to act differently in live areas from ones they know to be safe. The ethical justification for asking deminers to perform a trial in a safe area while leading them to think that it is mined in order to simulate live conditions more accurately, is debatable.
2. Finding enough mines or surrogate mines to provide a statistical analysis of the detection rate at a useful level of confidence is quite impractical as meaningful trials require hundreds of targets.
3. Sensitivity to factors beyond the control of the test protocol may be greater than sensitivity to the parameters being measured. For example, the exact depth of a small buried target may strongly influence the probability of detection. Placing a target and then re-filling above with soil makes precise determination of the depth difficult, moreover it may well not give the same results for some methods of detection as long-buried mines, and the precise depth of soil may vary slightly after heavy rain or vegetation growth. A deminer might be more willing to move a small pebble aside to put a mine detector closer

to the ground in a test area than in a live area with unknown mines/UXO present (see section 4.6).

The rest of this chapter addresses problems two and three above.

4.3 The statistics of missed mines

The only published paper of note on detection probability in humanitarian demining and associated confidence levels appears to be that of Voles [Vol98]. His method permits the calculation of results for a limited number of levels of confidence, namely the values of the cumulative Poisson function $F(x; \lambda)$ where $x = 2, 3, 4$ or 5 and $\lambda = 1$, and does not explicitly deal with the case of a trial where all the mines are successfully detected. The approach outlined below is both simpler and more general, and permits the analysis of the case where all the mines are detected.

Mine detection satisfies the conditions for a Bernoulli trial [MF85, page 57]:

- (i) there are only two outcomes (mine detected or mine not detected),
- (ii) the probability of success is the same for each trial,
- (iii) there is a constant number of trials (the total number of mines), and
- (iv) the trials are independent (locating a mine does not affect the performance of the mine detector when attempting to locate the next mine).

Thus the use of the Binomial distribution for probability calculations is justified. The conditions for using the Poisson approximation to the Binomial are also satisfied if the number of mines (n) is large and the probability of failing to detect each mine (p_{fail}) is small. In general the Poisson approximation can be considered valid if $n \geq 20$ and $p \leq 0.05$ or if $n \geq 100$ and $n.p \leq 10$ [MF85, Bar94a].

4.3.1 A conceptual model

A useful conceptual aid to understanding the statistics of mine detection can be to consider the model of a population of mines of which a fraction u are undetectable, and a detector capable of always finding all the rest. This gives the same results as a population entirely made up of theoretically detectable mines and a detection system with a probability of only $(1 - u)$ of locating each mine. A practical example of this conceptual model is the type of minimum-metal mines that are supplied with steel discs which can be optionally fitted as the mines are emplaced in order to make them easy to locate later with a standard metal detector (e.g. the TMA-4 anti-tank mine formerly made in Yugoslavia). If a few of the mines have not been correctly fitted with the discs then they effectively become undetectable; a metal detector will

find all of the mines with discs without difficulty, and none that lack discs. This is a reasonable assumption in practice if the mines have been laid at the correct depth. Defining the exact reason for indetectability makes no difference to the statistical analysis provided that it is a random process. In practice this condition may not be completely satisfied as failure to detect a mine may be due, for example, to specific soil conditions that prevail over some mines and not others in a non-random manner, but the consequences of this are considered to be negligible.

4.3.2 Definition of the problem of sampling

The problems of obtaining meaningful results from limited-size trials can be expressed thus:

The results of a trial of a sample of n mines (the trial size) show that a number of mines, x ($= 0, 1, 2, 3, \dots, n$), were **not** detected. What is the probability that an arbitrary proportion π of similar mines from the same population would also escape detection? What is the limit of confidence in this result?

Clearly if the number of mines used in the test (n) is very large there is a high degree of confidence that $\pi = \frac{x}{n}$. If the sample size is small it will less accurately represent the stock of mines as a whole and there is a certain likelihood that the value of π is larger than $\frac{x}{n}$ (or smaller than $\frac{x}{n}$ if $x > 0$). The trial result therefore depends on (i) the probability that any individual mine is detectable and (ii) the confidence that the sample accurately reflects the stock as a whole.

Taking the standard promoted by the United Nations of 99.6% mine clearance, an example of the conceptual model outlined above might be a crate of 1000 mines of which 996 are detectable (they have steel discs that make detection possible correctly installed) and four are undetectable (without the discs). It is obvious that a small sample, such as 20 mines, taken at random from the crate might well not include any undetectable mines. Clearly, it is not correct to conclude that because a small sample contains no undetectable mines that there are no undetectable mines in the crate. The question thus becomes, how many mines must be detected in a test to be sure that there are indeed very few undetectable mines in the crate, and what are the precise percentage probabilities?

4.3.3 Analysis using the Binomial probability distribution

The likelihood that a sample of size n , taken at random from a stock of mines having a proportion π of undetectable mines, will contain exactly x undetectable mines is

given by the Binomial probability distribution

$$f(x; n, \pi) = {}_n C_x \pi^x (1 - \pi)^{n-x}$$

where ${}_n C_x$ is the number of combinations of x events in n events.

Thus the likelihood that the sample will contain from zero to k (inclusive) undetectable mines is given by the cumulative Binomial function

$$F(k; n, \pi) = \sum_{x=0}^{x=k} {}_n C_x \pi^x (1 - \pi)^{n-x}$$

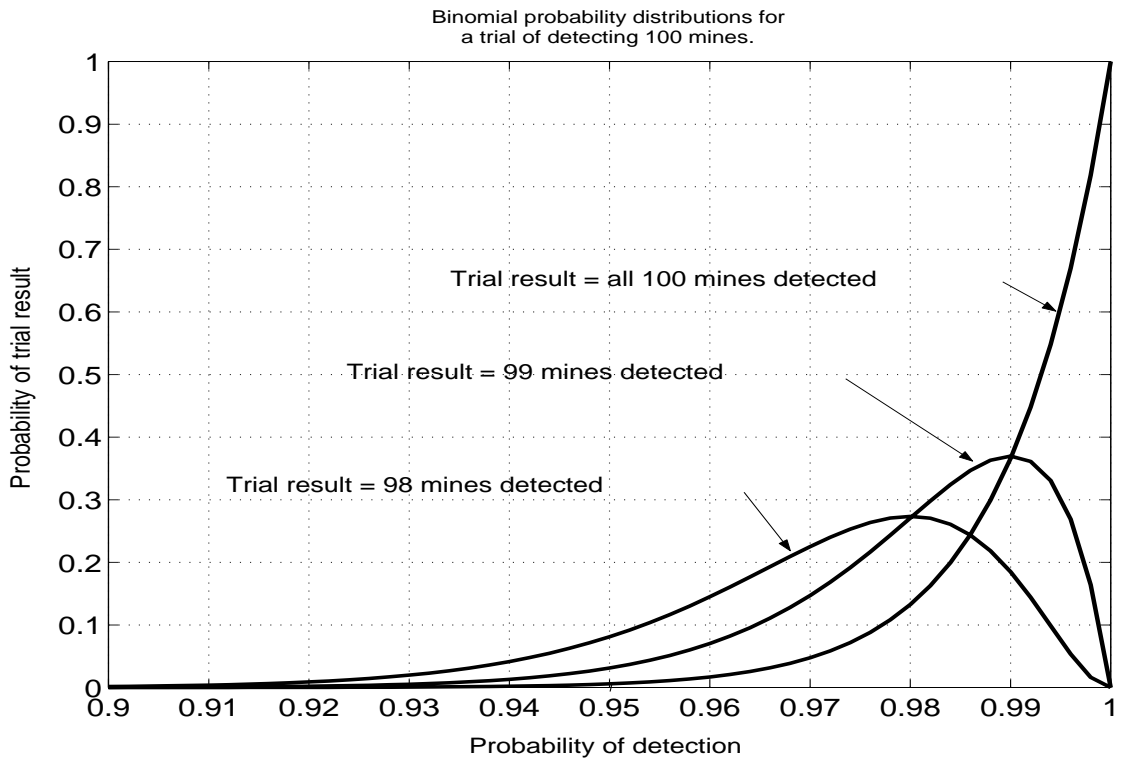

Figure 4.1: **Probability of result versus assumed probability of detection (fraction of mines that are detectable) for trials of 100 mines.**

Figure 4.1 shows the results of calculating the probability of the outcome of trials of attempting to find 100 mines, plotted against the probability of detection; the Binomial distribution relates the two probabilities as $p_{result} = binomial(x; n, \pi)$; where x mines escape detection in a trial of n mines by a detector with a p_D of $(1 - \pi)$. Clearly if the detector is perfect ($p_D=100\%$) the probability of finding all the mines is one, and the probability of failing to detect any number of mines is zero. When the p_D is 98% the most likely outcomes are one or two mines not detected.

In practice it is usual to discuss the case of a *lower limit of probability of detection* on the basis that any improvement in performance is welcome. When a detector is referred to as “having a p_D of 99%” the more complete statement is that the p_D is 99% *or greater* under certain conditions.

4.3.4 Using trial outcome to predict p_D

Predicting the outcome of a trial from a knowledge of the detector is less useful than using the results of a trial to find values for the probability of detection and the confidence in that probability. This is a standard problem in statistical quality control and is covered in text-books, for example Yamane [Yam73] who bases his text on the earlier work in the 1930s of Clopper and Pearson [CP34] and Barnes [Bar94a] who presents a nomogram adapted from Johnson and Kotz [JK69].

Two hypotheses are tested. These are:

H_0 : The mine detector performs to the required standard.

H_A : The mine detector is defective.

The associated errors are $\alpha = P(H_0 \text{ rejected when true})$ and $\beta = P(H_0 \text{ accepted when false})$. In quality assurance α is known as the producer’s risk and β as the consumer’s risk.

In testing mine detectors $(1-\alpha)$ is the confidence that the detector is accepted correctly from the test results (confidence in the result), and $(1-\beta)$, known as the power of the test, is the confidence that an unsatisfactory detector will be rejected. In the case of a trial where all the mines are detected β is clearly meaningless as the detector has been shown to function with a theoretical maximum p_D of 100%. In trials where one or more mines are missed β can be used to calculate the confidence with which an unsatisfactory detector would be rejected $(1-\beta)$, though this is likely to be so low that it is not useful.

The parameter α can be visualised as the fraction of the area under the tail of the probability curve lying below the value p_{limit} . This is illustrated in figure 4.2.

In most statistical quality assurance the area under both “tails” of the distribution curve contribute to the probability α ; manufactured items that are oversize as well as those that are undersize should be rejected. In mine detection there is no meaningful interpretation of a detector that is “too good” so α is exclusively the probability that the detector is not good enough, the area under the curve below the required minimum value of the probability of detection. This is the lower limit of the possible range of values of p_D for that value of α .

An arbitrary decision has to be made as to the relative magnitude of the p_D and

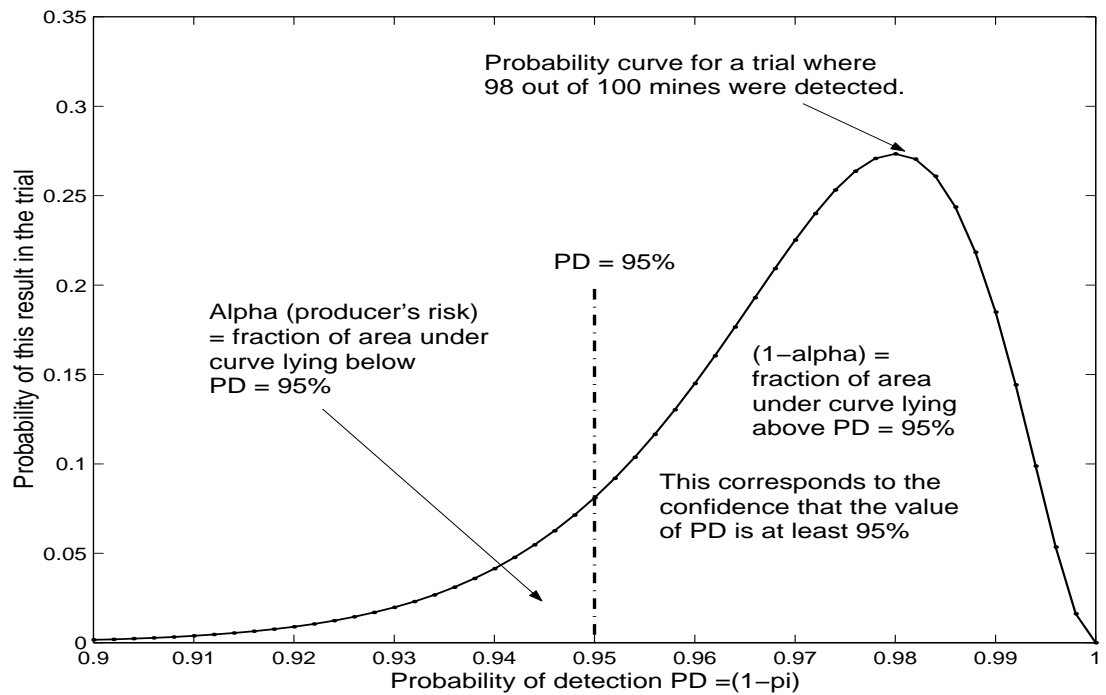

Figure 4.2: **Probability of result vs probability of detection for a trial of 100 mines, to illustrate α for a p_D of 95% .**

confidence $(1-\alpha)$ in order to analyse test results. This decision can also be visualised as moving the vertical “decision” line to the left or to the right on the graph of the probability function. As the line moves leftwards the area under the curve to the right of the line increases illustrating that as the minimum probability of detection required is reduced, the confidence that this can be achieved increases.

Direct calculation of the Binomial distribution is straightforward and can be performed rapidly using a digital computer. There is no longer any need to employ analytical methods including further assumptions to reduce the problem to a form that is more readily calculable; this was necessary until computer power became cheaply available in recent years and was therefore widely covered in textbooks. The solution to the calculation for evaluating p_D from the results of a trial of a detector can be performed by a direct numerical approach of seeking solutions that fit. Although this may appear clumsy and inelegant it produces unequivocal results without the need to make further assumptions about the data, and once the computer programming has been done it is a very quick method. To avoid computational difficulties that arise when the sample size is large, the result can be calculated using the identity $b(x; n, \pi) = b(n - x; n, 1 - \pi)$.

Numerical solution of the Binomial approximation leads to the conclusion that Voles [Vol98] misinterpreted one of his own assumptions and a numerical solution

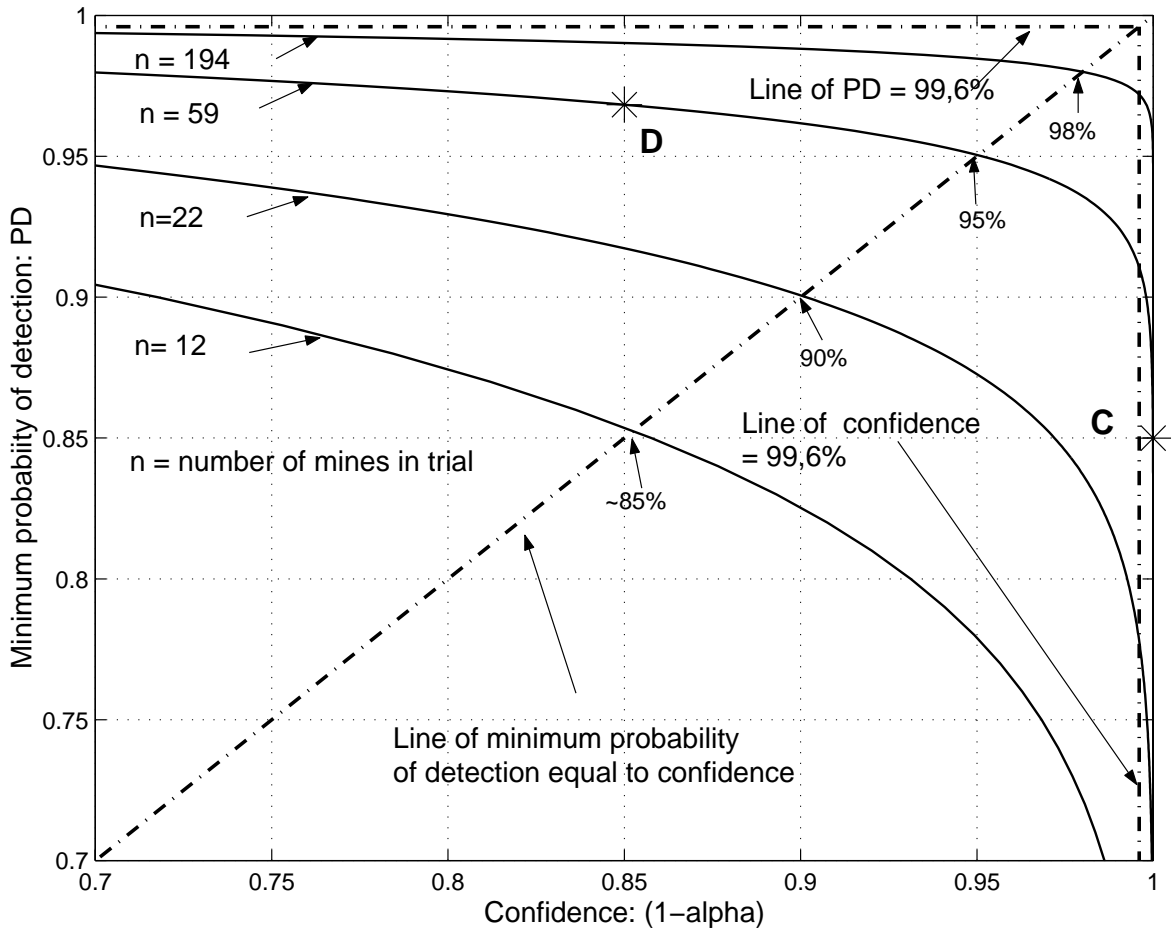

Figure 4.3: Minimum probability of detection vs confidence in the result, for trials in which all the mines are detected.

to the case of no undetected mines is indeed possible.

4.3.5 Selection of p_D and confidence

The selection from the results of an appropriate p_D and its associated confidence depends on the circumstances of the testing. The result of a trial is the set of points that form the curve of p_D versus $(1-\alpha)$ for the number of mines detected and undetected, as shown in figure 4.3. While investigating a new detection method it may be initially useful to build prototype equipment that is known to have an unacceptably low p_D in order to investigate how, under field conditions, this p_D varies with soil type, temperature, moisture or other factors. In this case a higher confidence and lower p_D would be appropriate.

Figure 4.3 shows that the curve is not symmetrical about the line of equality ($p_D = (1-\alpha)$) and whereas in a 100% successful trial of 59 mines a probability of detection of 85% can be stated with practically 100% confidence — point C on graph,

Confidence ($1-\alpha$) = Minimum probability of detection, %	Number of mines in trial		
	All mines detected	1 mine not detected	2 mines not detected
50	1	3	7
75	5	10	18
80	8	14	24
85	12	22	35
90	22	38	59
95	59	94	139
98	194	290	411
99.0	459	662	913
99.2	602	861	1177
99.4	851	1204	>1500
99.6	1378	>1500	>1500

Table 4.1: **Number of mines required in trial for a given minimum probability of detection**, where minimum probability of detection is taken to be numerically equal to confidence in the result.

a confidence level of 85% corresponds to a p_D of only 97% — point D. This serves to re-emphasise the difficulty of obtaining any meaningful results from measurement of the rate of detection in reasonably sized trials. The artificial separation of the two parameters of a test result, and the difficulty of the concept of *confidence* compared to the relative simplicity of the concept of *probability of detection*, lead to correct, but misleading, claims of such figures as 95% or even 100% success in trials. A p_D of 100% can only occur when the confidence is zero but the asymmetry allows confidence levels of 100% to be closely approached at values of p_D of well over 50%.

A useful approach to reduce the difficulty of presenting the results of testing mine detection equipment is to calculate a single value for both p_D and confidence by using the point where the two are numerically equal. The locus of these points is shown on figure 4.3 as a diagonal line. Solving numerically for the limiting case of $(1-\alpha) \geq \pi$ (i.e. confidence equal to probability of detection) gives the results shown in figure 4.4. Table 4.1 cites examples from the data. A trial of reasonable size can be seen to have p_D well below 100% by this method, finding 22 mines and missing none in a trial has a p_D (= confidence) value of just over 90%. In practice this is probably a more useful measure than expressing the same result as, for example, “99.6% p_D at a confidence of 8%.” A small improvement to the equipment is unlikely to change the 99.6% p_D figure by a significant amount but will be clearly indicated by an increase in the value of joint value for $p_D =$ confidence.

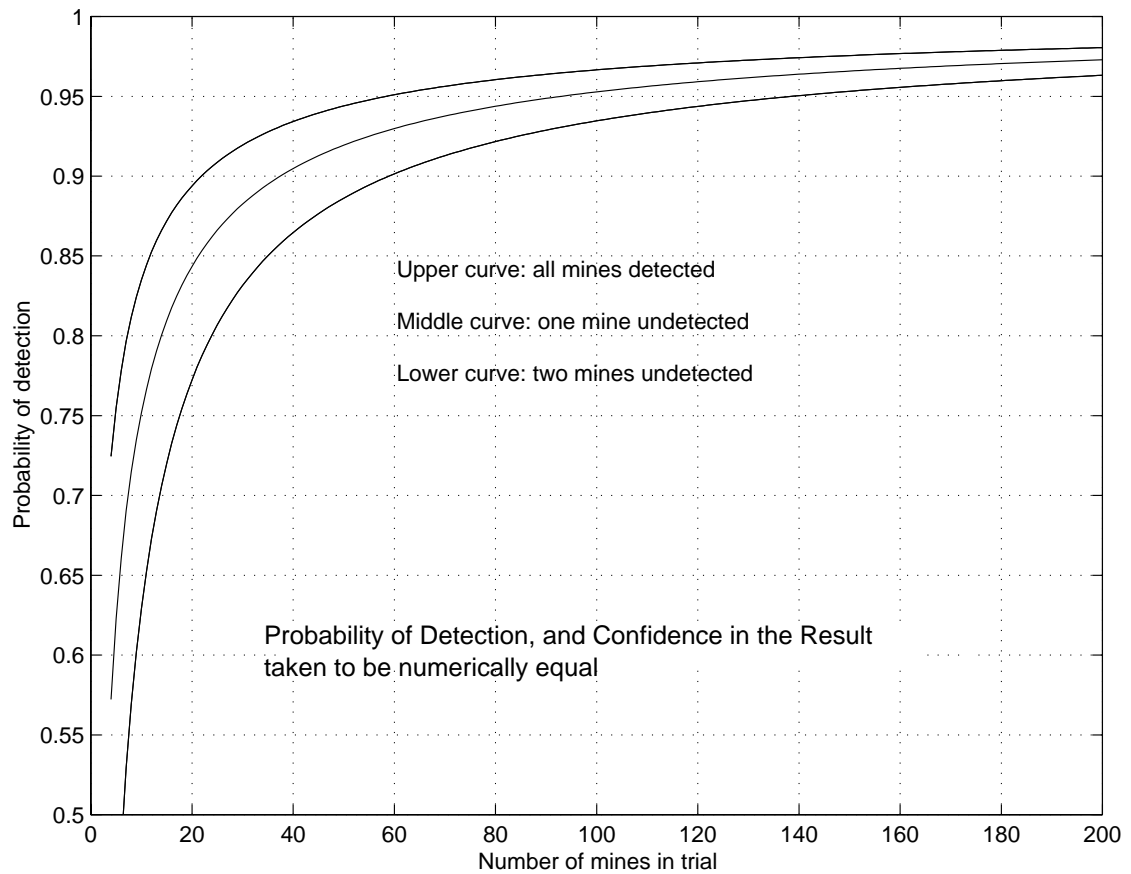

Figure 4.4: **Probability of detection vs size of trial when the minimum probability of detection is numerically equal to the confidence in the result.**

As table 4.1 shows, the size of a trial needed to demonstrate a probability of detection and confidence level both equal to 99.6% is 1378 mines successfully detected and none missed. A trial of this size would not normally be a practical proposition; the time and cost of preparing the hidden mine surrogates would be hard to justify.

4.4 Qualitative factors

Testing mine detectors “in the field” under realistic circumstances introduces so many variables that trials of a size that are feasible cannot be expected to yield results within an order of magnitude of the desired failure-to-detect rate. More information than just the crude detection rate must be included, either in a comparative manner or analytically, if the results are to be useful.

4.4.1 Limitations of “crude detection rate” data

The approach of defining a single overall detection figure determined by limited testing is not only unworkable in practice but conceptually flawed. Manufacturers of safety-critical systems such as passenger aircraft or nuclear power plants do not define the probability of failure of their products by waiting for occasional failures and then projecting a probability of failure rate from the results. Whilst the development of an exact method for testing humanitarian demining equipment is beyond the scope of this thesis, it is clear that mine detectors are not the only safety-critical equipment that requires testing, and that sophisticated methods have been developed to deal with this situation in other industries. The most distinctive characteristic of humanitarian demining is the wide variability of the environment. This variability implies a need for test methods and procedures that are as insensitive to the environment as possible. In this regard a crude detection rate of 99.6% is a very poor measure as it depends heavily on the environment, and on the training, skills and supervision of the operator and not just on the performance of the mine detector.

4.4.2 Human factors

The limiting sensitivity of a mine detector can depend in part on the skills and hereditary characteristics of the operator. The ability of different people to detect a small change in the pitch of a tone is known to vary by more than an order of magnitude [VLFM99], yet some metal detectors use a change of pitch to indicate a target.

The operator interface of mine detecting equipment can have a significant impact on how the equipment is used and hence ultimately the probability of detection. There are many non-technical aspects to designing equipment with an intuitive feel.

4.4.3 False alarms and unwanted alarms

Analysing the results of testing humanitarian demining equipment requires a workable method for dealing with false alarms. Taking once again the example of metal detectors, increasing the sensitivity increases the probability of detecting a minimum-metal mine, but also increases the number of small pieces of scrap metal detected. In mined areas where it is considered that there are no minimum-metal mines, deminers are known to reduce the sensitivity of the metal detectors to decrease the false alarm rate. Yet in doing so they are making a decision to reduce p_D . The statistical analysis presented above does not include any analysis of false

alarm data.

At present no distinction is made in defining the false alarm rate between mine-like objects that are identified by the detector as possible mines, and false alarms due to interference or sensitivity to non-mine-like objects. For example, a small piece of scrap metal found by a metal detector is considered a false alarm just as an area of highly mineralised soil that triggers the detector is considered a false alarm. For the purpose of analysing the detector's performance these are two separate cases. The small piece of metal might be the firing pin of a minimum metal mine that had already detonated; clearly it falls within the range of items that should be detected by this method and as such is an unwanted alarm but not a true "false alarm". To a deminer both types of alarm are a nuisance. However, for the purposes of analysis one is an unwanted but correctly identified alarm and the other is truly a false alarm. If false alarms can be clearly distinguished from unwanted alarms then the high unwanted alarm rate of metal detecting can be used to provide a modest improvement in the statistical basis of quality assurance. By considering all unwanted alarms as valid targets in a statistical analysis, the number of targets is increased to a level at which a measure of the crude rate of detection can begin to offer some meaningful results. However, this is not enough of a benefit to outweigh the nuisance of large numbers of unwanted alarms.

Currently, it is common to have a detector with the highest possible probability of detecting both mines and unwanted alarms in order to reduce the number of mines not found (i.e. p_D is at a maximum). To distinguish between an unwanted alarm and a mine, a separate detection method must be used which seeks to identify a different characteristic of the mine such as its dielectric constant in the case of radar systems, the presence of explosive in the case of olfactory and quadrupole resonance systems, or the physical presence of a mine case by prodding and excavation. The maximum usable p_D may in practice depend not only on the equipment under test but also on the associated secondary discrimination method and the operating procedures used. This makes a meaningful statistical measure of p_D more difficult to define.

4.5 Quality Assurance

Sampling methods of quality assurance (QA) are not appropriate to demining, yet they have been used. Some humanitarian demining organisations have, for example, carefully rechecked a part of a cleared area to be sure that they are confident that the demining has been done thoroughly. The commonly adopted current practice of removing all metal fragments from an area and then performing a check that it is entirely free from metal is a non-analytical form of QA.

Area cleared, m ²	Mines found	UXO found	Metal fragments found	Area cleared per mine/UXO found, m ² .
19 489	5	7	20 015	1624
76 264	6	9	35 931	5084
35 290	6	93 (in 20 groups)	72 220	1357 (per group)

Table 4.2: **Number of mines, UXO and scrap metal items found in three cleared areas in Cambodia.**

The scarcity of mines in some mined areas can be seen from the data from three mined areas visited in Cambodia in 1999, presented in table 4.2. It is clear that with any reasonable probability of detection there will be few, if any, mines/UXO overlooked. If one mine has been overlooked then the chance of it being found in a sampled QA test area is minimal — even if as much as 10% of the entire site is re-sampled then the chance of finding the missed mine is 1 in 10. If there were five mines found in the entire area and one not detected this amounts to a probability of detection, p_D , of only 83%. QA methods must demonstrate a high probability of being able to detect such a low p_D , certainly far more than just 10%.

Statements about the required clearance rate of 99.6% lack value if only five mines have been found; the confidence level with p_D equal to 99.6% in a trial of five mines, even when they are all found, is tiny — less than 2%.

If clearance is analysed on the basis of area, and each explosive item (or cache of explosive items as appropriate) is assigned a nominal area of 1 m², then it can be seen that the minefields visited in Cambodia (table 4.2) were well above 99.6% clear of mines and UXO *before* clearance work started. The figures for the three areas are 99.94%, 99.98% and 99.93% uncontaminated by area before demining. Clearly, this area-based approach has limited usefulness.

If the many items of scrap metal found by metal detecting are considered to have the same detection characteristics as the mines/UXO then an improvement in confidence in the mine clearance process is possible. Using all the scrap metal finds to form a statistical sample is not appropriate as finding large pieces of metal at or near the surface does not yield useful information about the ability of the metal detector and operator to find smaller buried targets. However, if there is a ratio of scrap metal to mines of 1000:1, and if one in ten of the scrap metal finds is small and buried, giving a signal similar to a mine, then the number of *mines and mine-like targets* in the sample area above would increase from six (five mines found and one missed), to 600. If all but one of these 600 targets are successfully located the p_D increases from 83% to 99.83% at 10% confidence. Guaranteeing an area to be “metal free” can be seen to offer a considerable improvement in certainty, but does not resolve

the problem of non-independence of the detection and QA methods. If a mine is missed, for example, because of a local anomaly in the soil then using the same detection method for QA will fail to detect the same mine for the same reason.

One of the more promising methods for QA is the use of dogs or artificial noses which can tell if explosive vapours are present in an area without necessarily being able to locate any individual mine. Any suspect area can be rechecked by hand.

In practice, a potentially useful method for guaranteeing mine clearance to a very high standard is to introduce not post-clearance sampling methods but methods that evaluate the performance of the demining operation as it is taking place. One way of doing this by using the concept of the “margin of detection” is proposed in section 4.6 below.

The strict operating procedures and supervision of manual demining are a method for maintaining an adequate quality of clearance. It is generally not the quality of current clearance methods that is a problem, but the time and cost of achieving the required standard and the lack of a way to guarantee that it has been achieved. Practical QA in the field may need to answer the question “Were the SOPs correctly and consistently followed?” instead of focusing on “Are there any undetected mines?” as it may not be possible to provide a meaningful answer to the latter question.

4.6 “Margin of detection”

In a typical trial two metal detectors may both find a set of targets without failure. However, connecting suitable measuring equipment, such as an oscilloscope, may show that one is at the limit of its ability to distinguish the targets but the other has a substantial reserve of performance and could still detect the targets under substantially more demanding conditions. Clearly their performance is not identical but the crude detection rate does not distinguish between them. To do so requires the introduction of a measure of how close the “signal” from each mine is to the limit of detection of the equipment being used. An estimate of how easily the detector identified all the targets, or almost all the targets, adds considerable useful information to its evaluation.

Similarly, in an area being cleared of mines/UXO, if all the mines already located have been found easily, and the geographical conditions are similar throughout the area to be cleared, then it is possible to be confident that further mines of a similar type and depth could be found readily. However, if the mine detector had been functioning at the limit of its performance while one or more mines were detected then it is possible that a mine buried slightly deeper, or one encountered by a tired

deminer at the end of a working shift, might be missed.

Thus the concept of the ease of detecting of a target, or the “margin of detection” is one way to resolve the problems of statistically meaningful testing of mine detectors and improve QA.

A further weakness of testing methods that rely solely on the crude detection rate is that a crucial evaluation is made when the desired signal from the mine/UXO is only just distinguishable from the “background” which is noise, clutter, interference and other undesired signals, depending on the detector type, soil, vegetation and other factors. The measurement of a signal barely different from the background is unlikely to give reliable or repeatable results. To avoid this it is common throughout engineering to use methods of extrapolation; the signal is measured under less critical conditions and a curve fitted to the results which is then extrapolated to define a point at which detection is just possible. The goodness of fit of the curve can be analysed statistically to provide measures of confidence and probable error limits. Individual manufacturers of mine detectors may well be using this method to enhance their products, what is required is a more general technique which can be used to compare different detectors.

A suitable measure of the margin of detection might be the ratio of signal to background noise at some point in the detector circuit, though such a one-dimensional measure is not capable of reflecting the data fusion skills of the human operator. For complex detection methods a measure of the effective “signal to noise ratio” may perhaps be made from probabilistic considerations. However, in defining the conditions during the measurement of the margin of detection the number of variables is large. The sensitivity of the detection process to some of these variables is also large; in the case of the limiting distance to a small metal target in air, the metal detector’s received signal can depend on the inverse fourth power of the distance from the detection coil to the metal fragment. Moving from 100 mm to 110 mm would cause a reduction in the received signal of 32%. A small pebble on the surface of a test area can clearly cause significant variation in the results depending on whether operators touch the pebble and push it aside or raise the detector over it (see also section 3).

The margin-of-detection parameter attempts to give a readily understandable result for a wide variety of targets. It can be evaluated by presenting a range of known targets to the detector under controlled conditions. Extrapolation of these results should give an acceptable estimate of the limits of the performance of the detector under ideal conditions. The performance of a known detector in the field can then be used to define the effect of the field conditions using the ratio of margin of detection. For example, a soil with a high metal ore content (e.g. laterite) might be considered three times more difficult for detection using a metal detector than an sandy soil,

Ratio of the power of the signal to the power of the background noise	Ratio expressed as decibels (dB)
100 000	+50
10 000	+40
1 000	+30
100	+20
50	+17
20	+13
10	+10
2	+3
1	0
0.5	-3
0.1	-10
0.01	-20

Table 4.3: **Power ratios expressed as decibels (dB).**

or dry sand might be considered three times more difficult for a radar system than moist soil.

These ratios may be conveniently expressed in decibels (dB) which are defined as $10 \times \log_{10}(\text{ratio})$. Table 4.3 gives decibel values for some ratios of the strength of the signal to that of the background, measured from the power of each.

In practice, an easy-to-detect target might be defined as 45 dB above background, and a difficult to detect target perhaps 5 dB above background using a standard mine detection system. A different detector that is being evaluated could then be measured and might perhaps give figures of 40 dB for the first and 6 dB for the second; this detector is more capable of finding the smaller target. Such ratiometric measurements allow direct comparison with existing “reference” equipment with which deminers are familiar, thus producing numbers with an immediate practical application.

Similarly, by inserting a standard target to a known depth, field conditions can be measured and might be described as producing, for example, a level 3 dB above normal background. The impact of this on the maximum depth of detection of small targets can be directly calculated. As most demining organisations check the functioning of equipment at frequent intervals against known targets this operation adds little extra effort to the work of demining.

4.6.1 Application of “margin of detection” to QA

When applied to quality assurance the concept of margin of detection has some appeal as it provides a working check on both the equipment and its operation.

If the depth of a target, either a mine/UXO or an unwanted alarm is known then the margin of detection can be used to provide a measure of the level of confidence of finding another similar target at the required depth of clearance in the same soil. In the case of a metal detector, if the target is a small piece of scrap metal that is excavated, the ease or difficulty of detecting it in air can be readily measured by dropping the scrap metal into a plastic container of known depth and placing the metal detector on top of the container. For example, if a particular target gives a margin of detection of 10 dB under the test conditions and was found at a particular depth then predicting the probability of detection of known minimum metal mines at a similar depth should be possible. Many of the factors that affect detector performance at the particular site can be combined into a single measure by following such a procedure.

By maintaining a record of all items found and the corresponding margin of detection, the performance of the equipment and operator can be continuously evaluated and a statistically meaningful quality assurance may be possible.

4.6.2 Use of unwanted alarms and margin of detection to enhance QA

Quality assurance could be immediately enhanced by introducing a simplified form of measurement of the margin of detection. This can be directly implemented with existing detectors. In terms of metal detection, small metal fragments can be characterised after excavation by the distance at which they can be detected in air; this gives a simple measure of their “detectability,” and depends on their size, shape and composition. If the depth at which they were detected in the soil is noted, the limits of detection for the particular combination of soil, mine detector and operator can be approximately categorised. From this simple analysis it would be possible to verify that a target similar to a minimum-metal mine would be found at a depth that would give adequate safe clearance of all mines. Research into this method should be able to determine if a rule of thumb that is easily memorised can be deduced, or a simple tool based on a nomogram developed. Simple categories that can be readily coded as “acceptable,” “marginal,” and “unacceptable” could be used, with appropriate colours or symbols.

Overall, measurement of the margin of detection is a simple and powerful tool that could be applied to both detector evaluation and quality assurance methods in

demining.

4.7 Summary and conclusions

Measurement of the crude detection rate of mine detectors fails to offer meaningful information on their performance in realistically sized trials. This has been demonstrated by a rigorous statistical analysis based on a clear conceptual model. The methods and concepts used fall within the scope of many textbooks describing statistical methods for QA; it is surprising that they have not already been adopted for use in humanitarian demining.

An alternative to quoting *probability of detection* and *confidence in the result* separately is suggested and examined.

The qualitative factors of the effects of the environment and the operator have been discussed and the need for methods of testing mine detection equipment that rely as little as possible on these factors explained.

The problem of achieving a statistically significant method of quality assurance after demining has been examined.

The concept of “margin of detection” has been offered as a potential way to resolve some of these problems. Its advantages and implementation were discussed in relation to testing mine detectors and also QA after clearance. Simple ways of implementing a crude form of margin of detection that are compatible with existing equipment and operating procedures are outlined.

Chapter 5

Research into improved prodding

5.1 Introduction

The research presented in this chapter had two basic aims:

1. To produce useful results that could be directly beneficial to humanitarian deminers.
2. To investigate whether an approach using incremental improvement of existing low-technology tools could be demonstrated as leading to practical results more quickly than the high-tech research route that has been widely used in humanitarian demining research. This “appropriate technology” approach includes:
 - Involving deminers from the start in the design process.
 - Taking into account the conditions under which humanitarian demining takes place in many poor countries.
 - Working on technologies that, at an early stage of the research, could be shown to enhance humanitarian demining .

Manual prodding/excavating is commonly used to find and identify the mines/UXO and metal fragments initially located by metal detectors, although it is frequently regarded as outmoded, unsophisticated, dangerous and in urgent need of replacement. A more careful investigation reveals that it is a very subtle and complex process, and humans are very well adapted to performing this task which involves fine tactile control with simultaneous observation and decision making. The computer based “data fusion” used in some advanced mine detection systems is unable to mimic the sensitive and reliable identification of targets by deminers. The author has already



Figure 5.1: **Combined prodding/excavating tool.** This tool is locally made in Cambodia at low cost.

argued [GT98b] that the success of prodding lies not in the simple tools used but in the human operator.

Prodding is also compatible with the subsequent process of mine/UXO uncovering for disposal; combining secondary detection with exposing the target is highly efficient. The difference between the prodder as a simple transducer and the trowel for uncovering and scraping away soil is not always a clear one and they are sometimes combined into a single tool. Figure 5.1 shows a photograph of the manner of use of a prodder locally made in Cambodia to the design of a demining organisation; this incorporates a sharp point for forwards prodding and a broad, flat blade for excavating.

However, prodding still needs considerable improvement where the ground is hard or impenetrable and research into this problem will be considered in some detail in this chapter. Easier penetration of the ground opens up the possibility of using tools which can detect mines by “close-up” techniques instead of remote detection, where “remote” in this context covers the range from immediately above the surface of the ground to airborne or satellite systems.

Any innovation in an activity as obviously dangerous as demining is likely to be taken up more rapidly in the field if it offers an incremental improvement to current practice than if it involves large changes in SOPs, and reliance on the safety

assurances of outsiders.

5.2 Sensing prodders: Location and discrimination from ‘close-in’

Close-in detection and discrimination offer a number of significant technical advantages over distance techniques. In general, approaching the target results in a very rapid increase in signal strength at the detector; in many techniques received signal strength follows an inverse square law, or higher power inverse laws. A sensor mounted on the tip of a suitable prodder can be brought in to contact with, or very close to, the target. This allows the use of such techniques as:

- Acoustic signature analysis in both audible and ultrasonic ranges. An ultrasound prodder system that characterises objects in contact with its tip is available from DEW Engineering and Development Ltd [DEW00] (see also section 3.5.1).
- Localised metal detection in a prodder for locating small pieces of metal scrap as the prodder passes close by them without encountering the physical presence of a mine-like object, see figures 5.2 and 5.4.
- Thermal conductivity measurements.
- Neutron activation (see chapter 6) using a physically small radioisotope neutron source in the tip of the prodder and a detector above the ground. This increases the neutron irradiation of a small buried mine by typically between one and two orders of magnitude (depending on its size and shape) and substantially reduces problems of background radiation from the source affecting the detector.
- Vapour analysis by passing a sample from close to the target to either a trained animal or an ‘electronic nose’ using one of the currently available technologies for vapour sensing of explosives.

5.3 Proof-of-concept sensing prodders

To investigate the practical application of close-in techniques five “proof-of-concept” sensing prodders were constructed using available technologies: a metal detector prodder, a magnetometer prodder, two different acoustic prodders and an ultrasound prodder. Details and photographs of these are given later in this section. These

were demonstrated to deminers and comments sought; in general the response was positive. This initial work was felt to be important as it attempted to break down some of the barriers between researchers and in-the-field deminers by

- (a) showing deminers the sort of tools that could be made and
- (b) by informing the researcher about their likely usefulness to deminers, and any specific problems with their transfer from the laboratory to the field.

Two main reservations were expressed by the deminers who examined the sensing prodders:

1. The need to evaluate the prodders in field trials under realistic conditions before offering a considered opinion.
2. Serious doubts about the usefulness of prodders that require deep insertion into possibly hard ground.

During discussions with deminers it became clear that these tools can only be considered useful in the field if the problem of penetrating medium-hard and hard soils, and those with a high gravel content, can be resolved. In soft soils, such as sandy beaches or deserts, excavation is rapid and easy so there is little or no demand for sensing prodders. Only where excavation is either slow or dangerous is the added cost and complexity of sensing prodders justified, and under these conditions prodders cannot be inserted readily or safely into the ground. Accordingly, the focus of the research was changed and work was begun on investigating the problem of penetrating hard ground, with the long-term goal of practical testing of the sensing prodders.

This early change of focus before wasting a great deal of time and effort showed the value of the approach taken in consulting active deminers in the field at an early stage in the research. Had this not been done it is probable that a further year's effort would have been expended on the sensing prodders with a similarly unsuccessful outcome.

The issue of danger from component parts of a sensing prodder becoming potentially dangerous shrapnel in the case of an accidental detonation was not addressed for the proof-of-concept models.

The following pages contain details of the proof-of-concept sensing prodders.

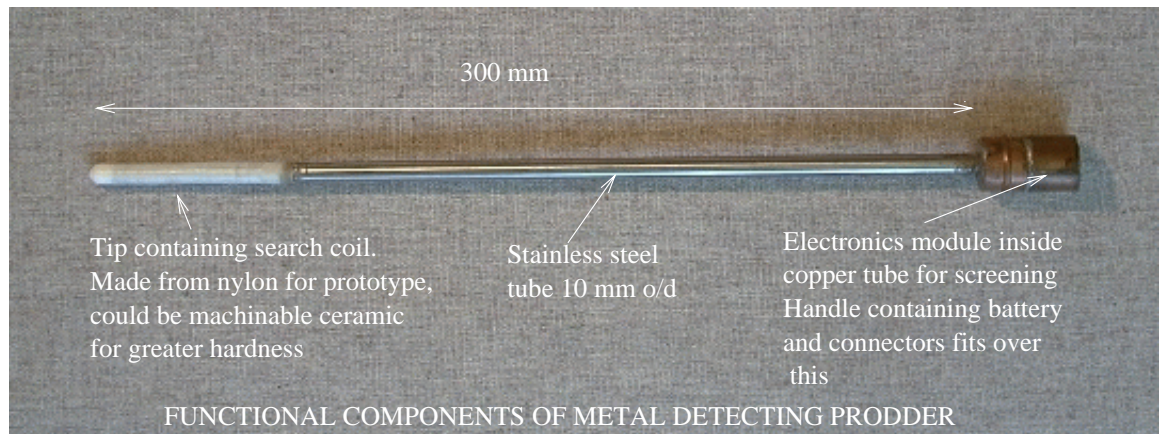

Figure 5.2: **Metal detector prodder.**

Figure 5.3: **Metal detector prodder circuit diagram.**

5.3.1 Metal detector prodder

This tool is designed to determine the depth of small fragments of metal; an indication similar to that of a standard metal detector is given as the coil in the tip of the prodder approaches a piece of metal. Repeated insertion of the prodder detects the physical presence (or absence) of a mine-like object surrounding a small piece of metal. During testing small metal objects could readily be localised, the prodder gave a maximum signal when the object was just ahead of the front edge of the ferrite rod, approximately level with the end of the prodder. A staple made from mild steel with a mass of about 0.05 g could just be detected at a distance of about 15 mm from the prodder in air; this is probably less sensitive than is required for field use but was more than adequate for initial trials. Circuit details are given below with a circuit diagram in figure 5.3. The audio output could be heard using an earphone connected to the prodder or with an amplifier and loudspeaker as used for the acoustic prodders (figure 5.6).

A demonstration of the proof-of-concept model at a major conference on mine detection [GT98b] received a positive response from some of the deminers present.

Metal detector prodder circuit details

A solenoidal coil of 200 turns of Litz wire on a ferrite rod 5 mm in diameter, mounted near the tip of the prodder, formed part of the tuned circuit of a negative impedance oscillator. Oscillator frequencies of 2 kHz to 25 kHz were tried; a final decision on frequency was to be taken after field testing. The oscillator output was buffered by a J-FET and then clipped to a square wave and passed to a phase-locked loop (PLL)

with a loop time constant of a few seconds. The PLL was configured to run at a frequency of about 200 kHz and lock on to a harmonic of the oscillator. Any change in the oscillator frequency, due to metal items affecting the inductance of the coil, was detected by mixing the oscillator output with the VCO of the PLL and listening to the difference frequency. The PLL slowly locked on to the oscillator removing the need for adjustable compensation for the background. This gave a good “feel” to the prodder; if a small metal item was suspected a brief pause with the prodder stationary caused the output to settle and the prodder could then be moved back and forth to locate the metal. The magnitude of the oscillator output could be used to measure the Q of the coil to give more information about the target, though this was not implemented in the proof-of-concept model.

The use of J-FETs simplified the biasing of the circuit considerably and thus permitted the component count to be reduced. This was important as the oscillator had to be mounted in the prodder handle, as close to the coil as was practical, and had to be very well screened to prevent capacitance coupling to the operator’s hands from influencing the output. Copper tubing (in the form of standard plumbing parts) was used to shield the prototype, and this left relatively little space for the circuit.

5.3.2 Differential magnetometer prodder

The magnetometer prodder was an alternative to the metal detector for the precise location of ferrous scrap. The advantage is that it is possible to locate metal items both axially (depth) and radially (direction) though the radial location was not particularly precise and its sensitivity depended on the orientation of the prodder with respect to the earth’s magnetic field. Many heavily mined countries are tropical or sub-tropical and hence have a relatively small vertical component to the terrestrial magnetic field, which is optimal for this type of prodder.

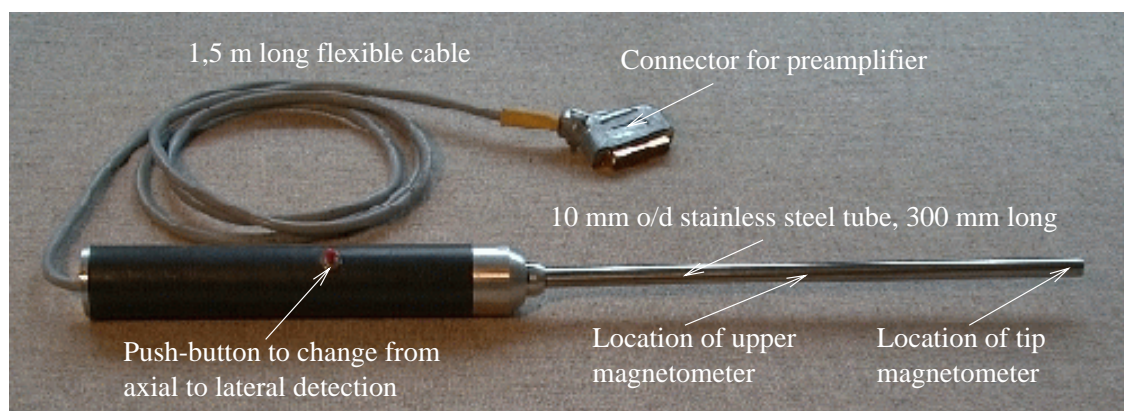

Figure 5.4: **Differential magnetometer prodder for precise location of ferrous items.**

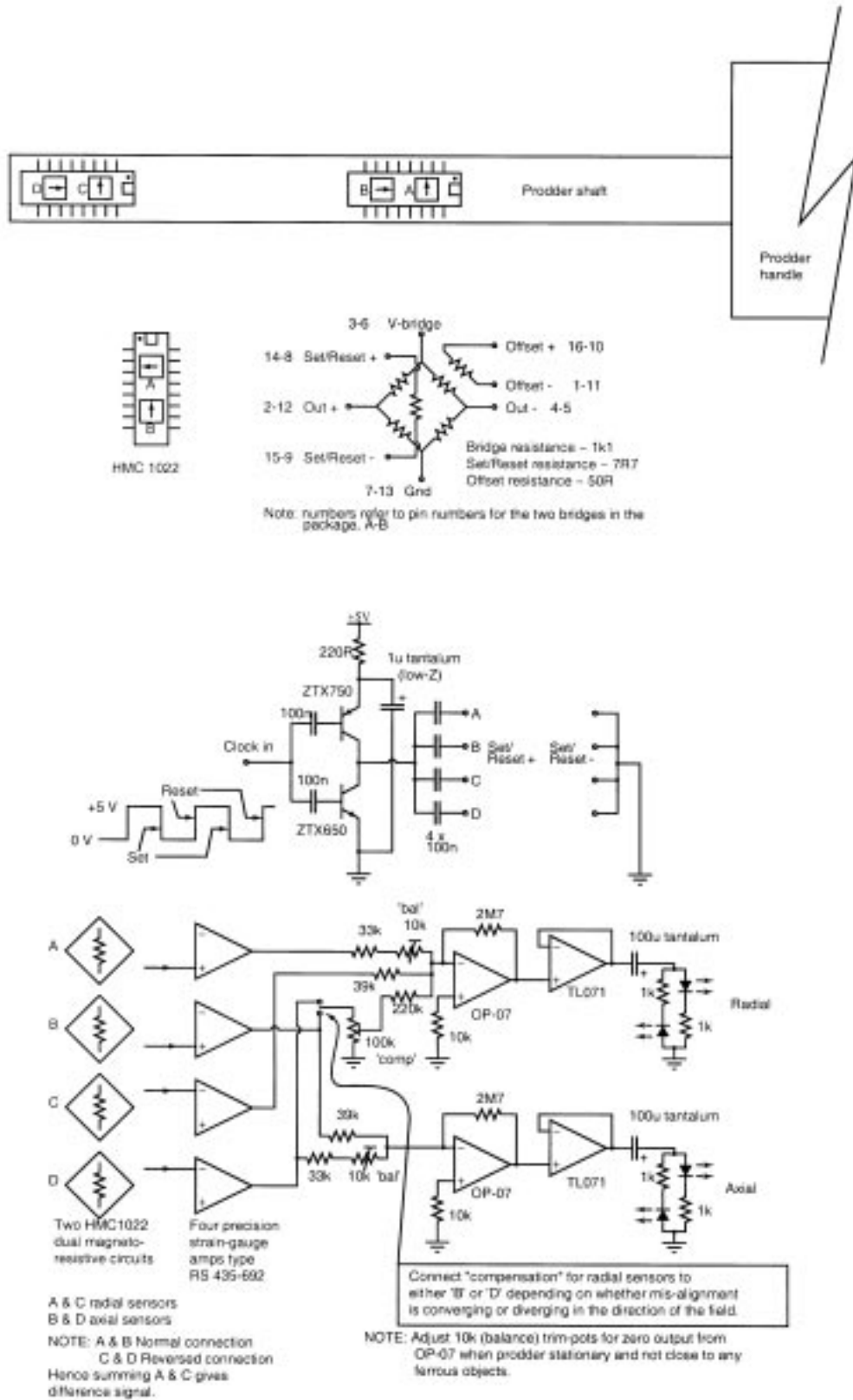

Figure 5.5: Differential magnetometer prodder circuit diagram.

Magnetometer prodder circuit details

The prodder was based on low-cost (about £25) magneto-resistive sensors type HMC1022 manufactured by Honeywell [Hon00]. Each HMC1022 contains two orthogonal sensors capable of detecting magnetic fields as small as a few nanotesla. The sensors are based on a bridge configuration and are suitable for use with standard strain-gauge amplifiers. Two HMC1022 surface-mount devices were used, one inside the prodder at the tip and the other about half-way along the shaft which is made from a tube of non-magnetic stainless steel of 10 mm o/d. One of the orthogonal sensor directions was along the prodder shaft (axial) and the other was across the shaft (radial).

Initial results of the axial sensors were encouraging. The sensitivity varied with the precise orientation of the prodder relative to the earth's magnetic field but a staple made from mild steel with a mass of about 0.05 g could be detected at a distance of about 15 mm from the prodder in air. This was the same sensitivity as the metal detector prodder (figure 5.2) . The precision of the axial position information was greater than the metal detector.

The radial position information was much more influenced by the background magnetic field than the axial (the detected axial field varies little as the prodder is inserted into the ground, the radial field varies considerably as the prodder is rotated). Balancing the two radial sensors for cancellation was difficult and would require a degree of precision in the mechanical assembly that was not possible with the proof of concept model. However, it was possible to demonstrate the concept of detecting the direction of a target relative to the prodder by using steel washers and nuts of greater than 10 g mass.

Differential magnetometer prodder circuit details

A circuit diagram for the magnetometer prodder is given in figure 5.5. The bridge output magneto-resistive elements were connected to standard strain-gauge amplifiers (RS part numbers 846-171 and 435-692); the bridges on the upper magnetometers had reversed connections so that a simple summing circuit could be used to give a difference output to detect local disturbances to the background magnetic field. The difference signal was used to drive a visual indicator; an audio output based on a VCO was also planned.

The visual indicator used two LEDs which illuminated in turn as the magnetometer passed a ferrous object which was perturbing the earth's magnetic field. This was simple and intuitive for the proof of concept prodder but would be unsuitable for use in mined areas where deminers' visual attention should not be diverted from observing the area being investigated, hence an audio output was planned.

To improve the balance of the radial sensors a small amount of the signal from the adjacent axial sensor was added to the upper radial sensor. By varying the gain of this additional signal the measurement ‘vector’ could be effectively steered through a small angle to ensure that the two radial sensors were detecting exactly parallel fields.

The Honeywell magnetometers can be polarised by a current pulse through their internal set/reset circuit. Repeated changes of polarisation allow precise measurement of very small magnetic fields by using the peak-peak output and thus cancelling small DC offsets due to imbalance and drift in the circuit. This was not implemented on the proof of concept prodder which used a fixed reset period of about five seconds generated by a 555 timer. The set/reset circuit was taken from the Honeywell applications information [Hon00].

5.3.3 Acoustic prodders

The acoustic prodder tips were designed to fit onto a standard 8 mm o/d, 6 mm i/d steel-tube prodder shaft and could house either a miniature microphone or a piezo-electric ‘bi-morph’ element (part number 285-784 from RS Components). The audio signal was fed through a flexible cable to a small battery powered amplifier and loudspeaker which could be belt mounted; an earpiece could be used instead of the loudspeaker. The amplifier used an AGC and an audio compressor circuit for ease of operation.

Mounting the microphone at the tip of the prodder was found to minimise the influence of the acoustic properties of the prodder shaft and handle on the desired sound generated by the prodder tip in contact with an unknown object.

The human ear and brain are very sensitive to the timbre of sound and provided a sophisticated analytical tool for processing the output of the acoustic prodder. In tests with a panel of three listeners using both a microphone and a piezo-electric pick-up, it was found that simple tapping of the target yielded less information than scraping the tip of the prodder on the target by moving it from side to side gently or by rotating it. When this was done the characteristic sounds of stone or cement (gritty sound), tree roots (dull, rough scrape), plastic box (smooth scrape), and metal (metallic or ringing sound) could be readily identified. The prodder with a piezo-electric pick-up gave clearer sounds than the one with a microphone. Filtering might further improve the discrimination and reduce the effect of the acoustic properties of the prodder itself.

Possible further work included exciting the prodder at a low audio frequency and then listening to the harmonics generated when the vibrating tip was brought in

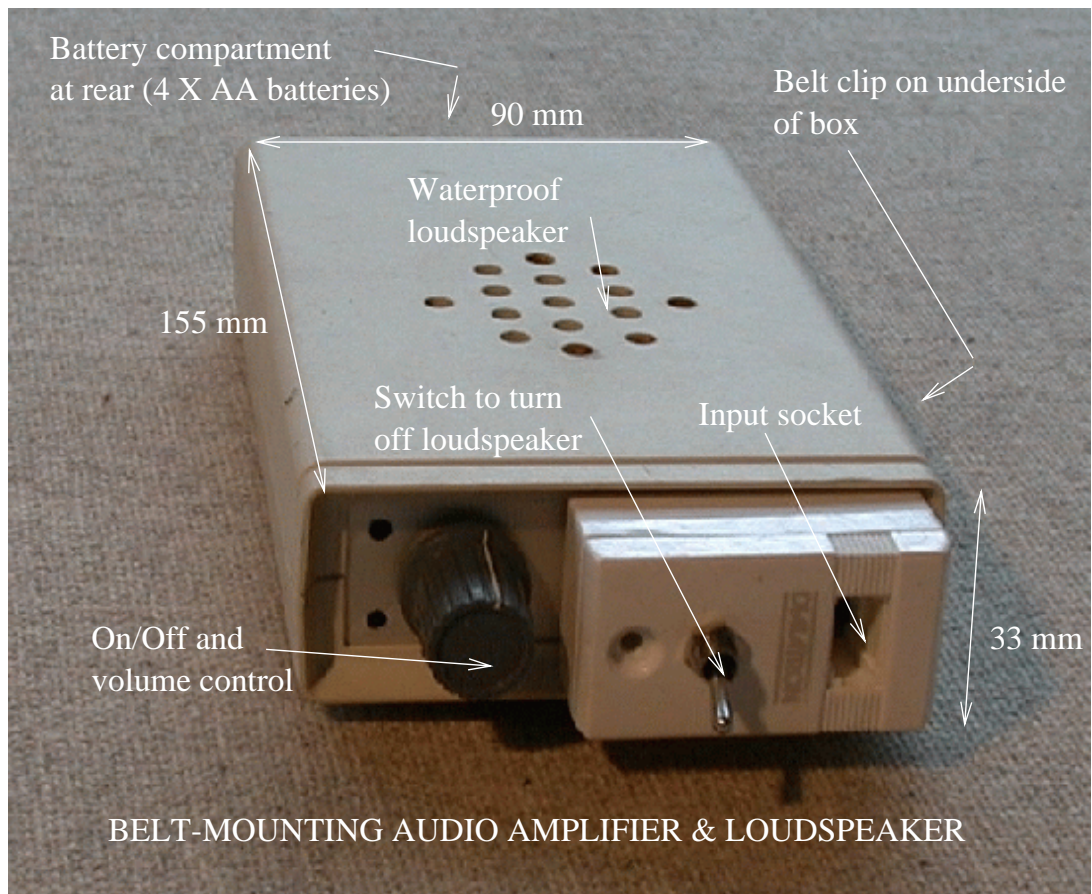
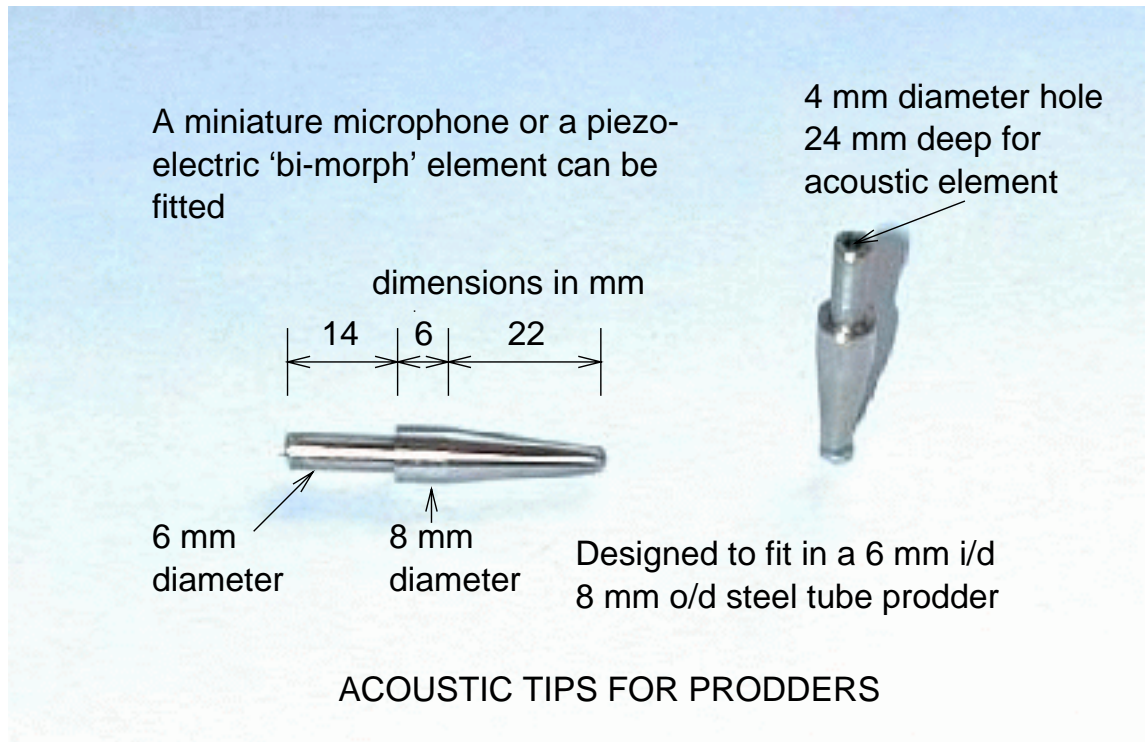

Figure 5.6: Acoustic prodder tips and amplifier.

contact with a solid object. The degree of hardness and bounce of the object should significantly affect the resulting harmonic structure; removal of the fundamental by an electronic filter would be straightforward.

5.3.4 Ultrasound prodder

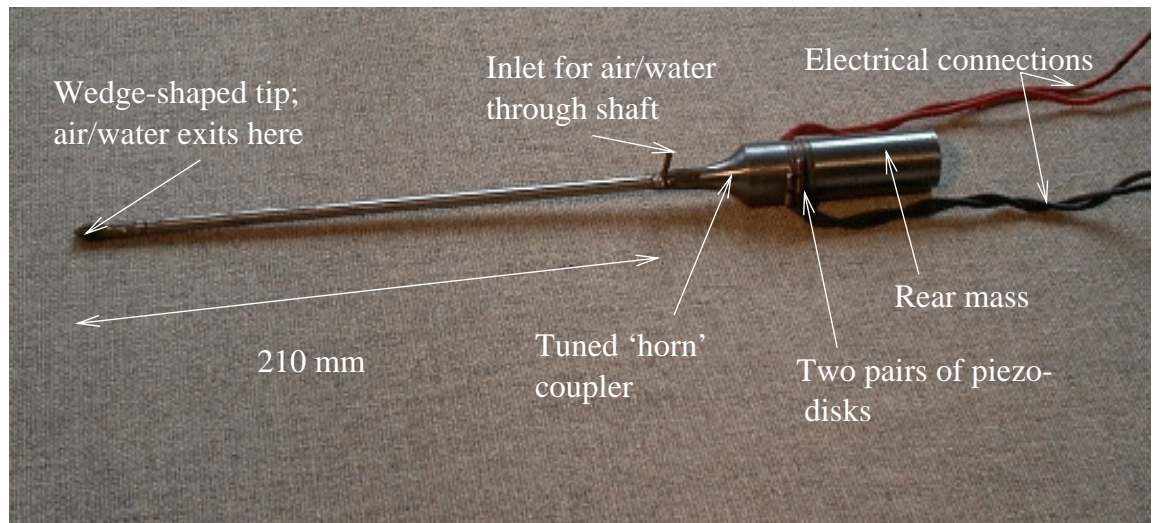

Figure 5.7: **Mechanism of ultrasound prodder.**

The design specification of the ultrasound prodder was as follows:

- Prodder shaft 210 mm long, 6 mm diameter, hollow to allow air or water to be passed to the tip. The air flow can be used to clear debris, or water used to soften hard ground and improve coupling from the tip to the ground.
- The prodder shaft was designed to work in a longitudinal vibrational mode with a wedge-shaped tip; the wedge tip was chosen as it was the most effective in initial testing.
- The driver elements were four piezo-electric disks for a maximum total power input 40 W.
- The designed operating frequency was approximately 30 kHz.

The prodders were designed and manufactured by Morgan Matroc Ltd, Southampton, to the specification of the author. Initial proving of the design and characterisation of the prodder was done by Morgan Matroc [Wie98].

The results of testing the ultrasound prodders can be summarised as:

- The resonant frequency was approximately 29 kHz; the impedance at resonance in air 34Ω , the impedance at resonance loaded with soil approximately 120Ω . Off-resonance, the impedance in air rose to $26 \text{ k}\Omega$ at 30.3 kHz (an increase of nearly three orders of magnitude for a 3% increase in frequency).
- Maintaining the longitudinal vibrational mode in the shaft of the prodder was very difficult. The shaft was easily provoked into transverse and mixed vibrational modes that dissipated energy along the shaft and did not adequately excite the tip of the prodder.
- Very accurate tracking of the resonant frequency was required to maintain power transfer into the transducer.
- Penetration of test soils was better than a plain prodder but the improvement was not great.

A better approach might have been to investigate the resonant frequencies of gravel particles embedded in hard soil and then design a vibrating prodder to operate at these frequencies, which are thought to be about 300 Hz, in order to loosen the gravel.

Due to (i) the serious problems of maintaining the longitudinal mode of oscillation (ii) the advantages of rotary prodders during the laboratory testing and (iii) the announcement of the DEW ultrasound probe in Canada [DEW00], the work with ultrasound prodders was set aside before useful results were obtained.

In retrospect, after the difficulties encountered in field-testing the rotary prodders, further work on the apparently silent and vibration-free ultrasound prodders would have been amply justified. A shorter excavating tool that would have been easier to design and to maintain in the correct vibrational mode than such a long narrow prodder might have been a useful approach.

5.4 The problems of prodding in hard ground

At least four approaches can be considered for maintaining a reasonable speed of operation in mine/UXO clearance by prodding/excavation in hard ground.

1. Push harder and accept the increased risk; at the same time choose working methods which minimise the chances of accidentally detonating a mine while pushing hard, e.g. approach at a shallow angle or horizontally from a trench. This appears to be the most common method of demining hard ground.
2. Devise tools and equipment to make entry easier; either by (a) a method of penetrating hard ground with low force or by (b) a method of softening the ground before prodding.
3. Mechanise the procedure, fit a remote control system, and use as much force as is required; at worst a detonation will damage the equipment but will not injure the operators.
4. Postpone clearance. This may be a temporary postponement to wait, for example, for the start of the rainy season to soften hard-baked mud or it could be a decision to indefinitely postpone activities in a difficult area and clear other areas first if they are easier or safer to clear.

5.4.1 Do deminers push too hard while prodding?

Field observation and anecdotal comments suggested that many deminers routinely push prodders with more than enough force to detonate some mines. This is supported by the Afghan accident data for the first half of 1999 [Rah99a] showing that over 80% of accidents were due to prodding on to PMN type anti-personnel mines and detonating them. In general deminers do not detonate mines during prodding, even when pushing hard, because:

1. Mines are scarce; even in densely mined areas most targets are scrap metal (see table 4.2).
2. Most mines are the right way up so a deminer prodding at a shallow angle hits the side of the mine case first, and not the pressure plate. Mines deliberately set facing sideways are a known cause of accidents [Smi00c]. (See also section 5.8.1).

What constitutes a “safe prodding force” ?

No matter how small the force used in prodding there is always a risk that a mine is already at the point of activation due to:

- (i) force on the trigger mechanism from such causes as soil movement or vegetation roots that have grown around it,
- (ii) aging of the mechanism, or
- (iii) other causes.

The force required to detonate common AP mines is usually given as a range. Jane’s reference book [Kin98b] gives the values shown in table 5.1 for some typical mines with low operating forces.

The force required to trigger the mechanism of a PMN mine was investigated using a single sample which had the detonator and explosive charge removed. This type of mine has a rubber cover over the whole of the top of the case. Applying force with a prodder normal to the top face in the centre of the mine required about 80 N to trigger the mechanism, at the edge this reduced to about 50 N, which increases the risk for deminers. Applying the force at an angle of 45 degrees to the face, near the edge of the mine, required about 60 N to trigger the mechanism.

From these figures it can be concluded that prodding with a force of about 25 N is reasonably unlikely to detonate a mine, though 50 N (5 kgf) is regarded by some authorities as “safe”. Knowledge of the types, age and condition of the mines likely to be found, and ground conditions, influence the way that prodding is undertaken.

Mine	Country of origin	Operating force, N
Type 72	China	50–100
Type 72B	China	25
Type 58 AP blast	China	50–100
PMN	Russia	80–250
R2M1	S Africa	30–80
PMA-1A	Yugoslavia	>30
PMA-2	Yugoslavia	70–150

Table 5.1: **Force required to detonate some AP mines.** Data from Jane’s “Mines and Mine Clearance” third edition. (All units are given as “kg” in this source whether labelled as “operating pressure” or “operating load” — they have been converted here to force in newton using a factor of 10 N = 1 kgf).

5.4.2 Measurement of force used while prodding

Field measurements were made to investigate the anecdotal evidence that deminers routinely use large forces when prodding. A three-axis force sensing prodder was designed and constructed by the author; this used strain gauges to measure the force applied axially and in two orthogonal directions, nominally “vertical” and “horizontal”. The specification used is shown in figure 5.8. This tool was connected to a purpose-built pre-amplifier, the output of which was captured by a commercial data-logging system (Thurlby-Thandar VIPS) based on an electronic “module” connected to the parallel port of a portable 486-based computer. An general assembly drawing of the internal mechanism of the prodder handle is shown in figure 5.9, and a photograph of the finished prodder and the various blades that could be attached to it is shown in figure 5.10.

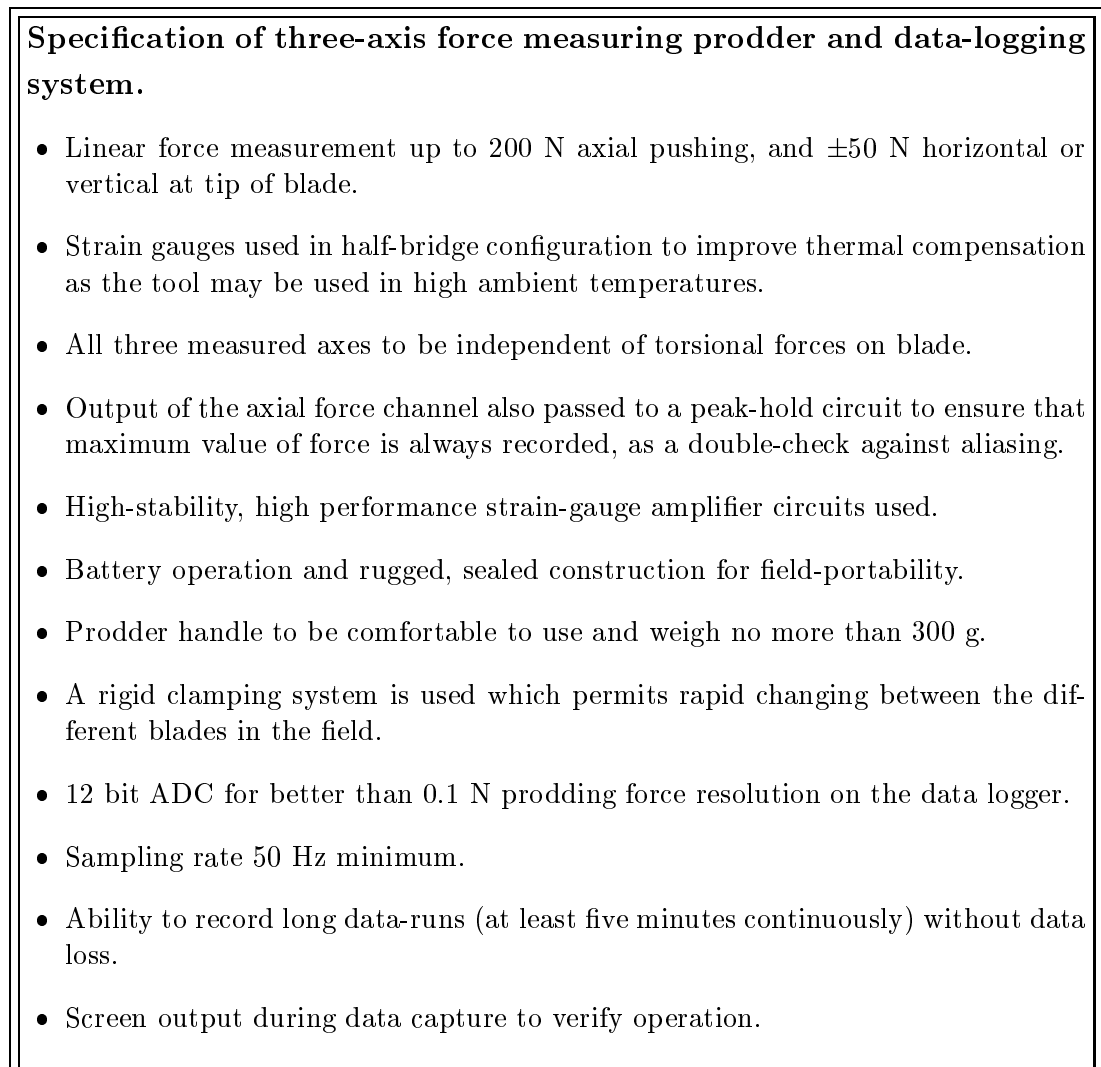
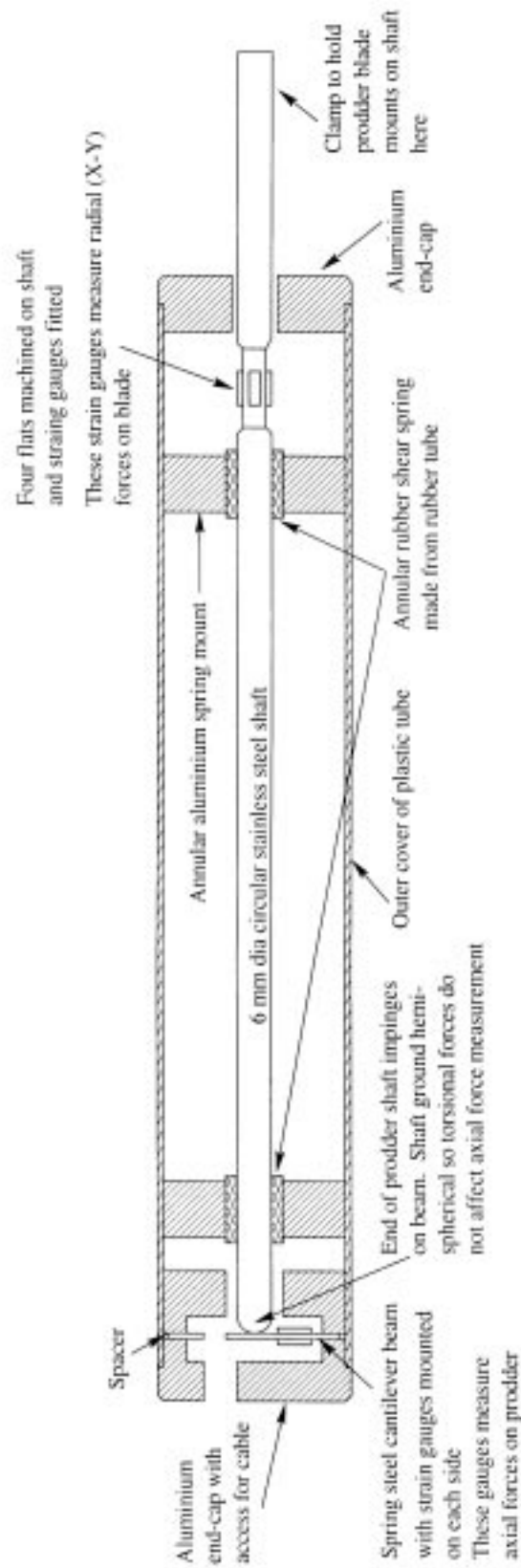

Figure 5.8: **Specification of three-axis force measurement prodder system.**

Calibration with weights showed the prodder output to be highly linear over a wide range of applied force, as shown in figure 5.11.



GENERAL ASSEMBLY (MECHANICAL) OF THREE-AXIS FORCE SENSING PRODDER HANDLE

Figure 5.9: Drawing of mechanism of 3-axis force sensing prodder handle.

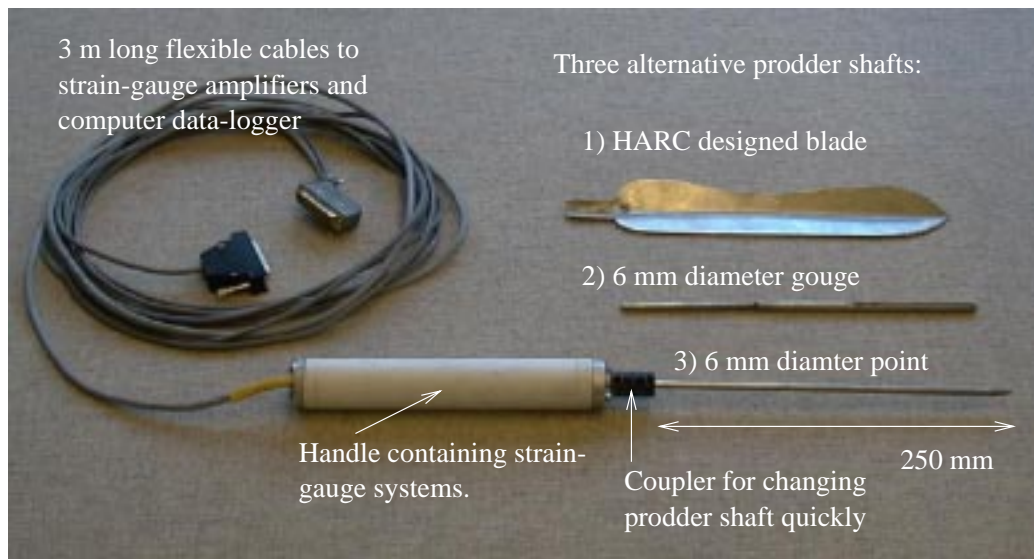

Figure 5.10: Photograph of three-axis force sensing prodder and blades.

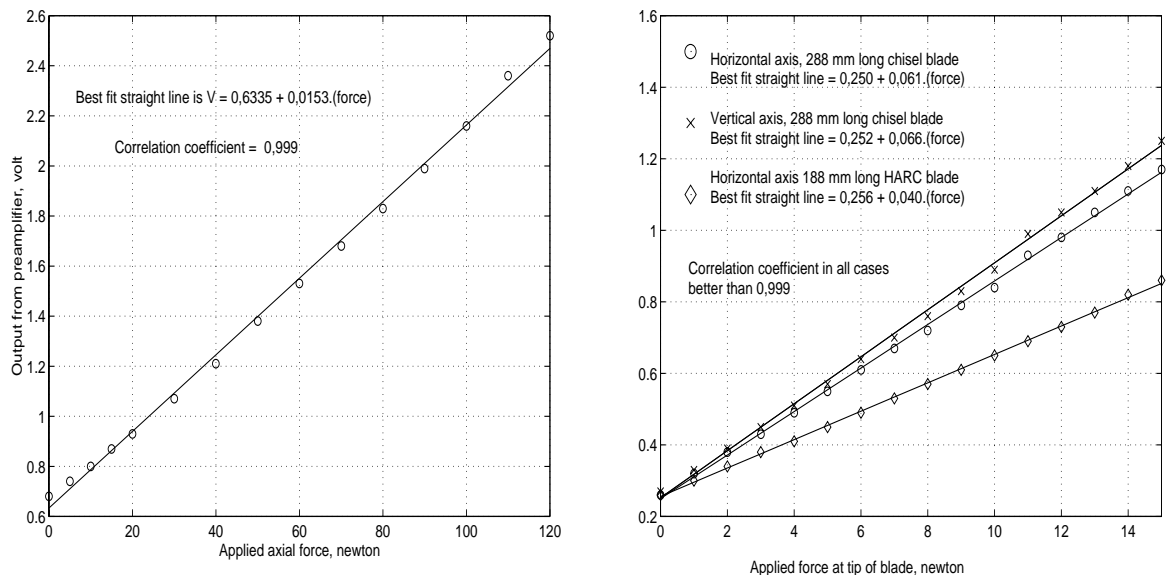

Figure 5.11: Sample calibration curves, three-axis force sensing prodder.

The three blades used in the trial were

1. A 6 mm diameter steel rod with a pointed end.
2. A 6.5 mm chisel-tip made from a hard steel woodworking gouge.
3. A wide blade designed by the HARC demining research centre in Islamabad, Pakistan for use in the hard soils of Afghanistan.

The force measuring system was used by deminers in the field in two sites in Afghan-

istan, one near Jalalabad and the other in the hills overlooking Kabul. Afghanistan was chosen for this work as it has mined areas with exceptionally hard and stony soils and very little vegetative cover. The first site was one that had already been cleared by manual demining; the second was a site in the process of being surveyed; the areas used were those which had been declared clear by dog teams earlier in the week. After testing was complete a mine was found by the survey team in an adjacent area, thus confirming the test site as representative of a mined area.

Further measurements were made in Islamabad, Pakistan where staff from the HARC demining research centre prodded in a test area with soils of similar hardness to those tested in Afghanistan.

Test procedure for measuring force used while prodding

The deminers undertaking the test worked according to their SOPs using full protective equipment. They were asked to start by following their usual practice of excavating a shallow trench away from the mine using as much force as required to break through the ground. They were then asked to work forwards from the trench as if they were closely approaching the target, again, this was their standard practice. The force used to dig the shallow trench a safe distance away from the mine may make the deminer less sensitive to the force subsequently used for the close approach to the mine in the same way that, after lifting a heavy object, lifting a lighter one seems easier than usual.

Results and analysis of measuring the force used during prodding

Without exception the Afghan deminers disliked the three blades tested. In Afghanistan deminers commonly use the bayonet from an AK47 assault rifle to excavate. This is far from an ideal tool as it is very short so that the deminer's hand is close to any accidental detonation and in the event of a detonation the blade is likely to inflict very serious injuries. However, the size and the heavy handle means that these bayonets have a sturdy and balanced feel and they appear to be well-liked.

The blades tested were all much longer than a bayonet which made them clumsy to use while prone, but not difficult to use while squatting. All the Afghan deminers interviewed liked the gouge chisel most and the wide HARC blade least of the three. Due to limitations of time it was not possible to obtain a bayonet and adapt the blade to fit the three-axis measuring handle.

The force used during the initial trench-digging included peaks up to 223 N. Part of

a typical plot of total force against time during the subsequent “careful excavation” phase is shown in figure 5.12. Each of the peaks represents one prodding action. An expanded section of this data is shown in figure 5.13 with the angle from axial of direction of the total force. The relationship between angle and prodding force can be clearly seen.

Spectral analysis of the data confirmed that the sampling rate used for data-logging was adequate to avoid serious distortion due to aliasing; the prodding force was sampled at 50 Hz and the highest power level of any of the data just below the Nyquist frequency was less than -30 dB below the peak power level. Comparison of the input and the output of the peak-hold circuit confirmed that the peak forces were accurately captured.

Data processing of force measured while prodding

All data processing and plotting of results were done with the Matlab computer package. After the baseline offset (caused in part by the weight of the blade used) was removed, the calibration factor for the appropriate blade was applied. The force normal to the axial was calculated from the “horizontal” and “vertical” components and added vectorially to the axial force to give the total force applied; the direction of the total force vector (angle from axial) was also calculated.

Scattergrams of total force against angle showed that large forces were predominantly axial. A typical example is shown in figure 5.14. The large angles at low force were generally due to a sideways scraping action to move aside debris that had been loosened by prodding and picking.

The peaks of each prodding cycle were extracted using a simple maximum-value algorithm. All peaks below 25 N were discarded and the remaining data examined.

There were not enough separate recordings to provide a statistically meaningful analysis of the difference in force used between different deminers and the different blades. This was partly the result of a software problem in the commercial data-logging package, and partly because the explosion of a truck-bomb in the city of Kandahar, near the research area originally proposed, severely curtailed the time available in Afghanistan.

The data from all the tests performed in Afghanistan were combined, as were the data from all the tests in Pakistan. The peak force used was analysed by counting the total number of peaks below a threshold magnitude; this magnitude was increased from zero in increments of 5 N. As all the peaks of less than 25 N had already been discarded there were clearly no peaks in the ranges <5 , <10 , <15 , <20 and <25 N.

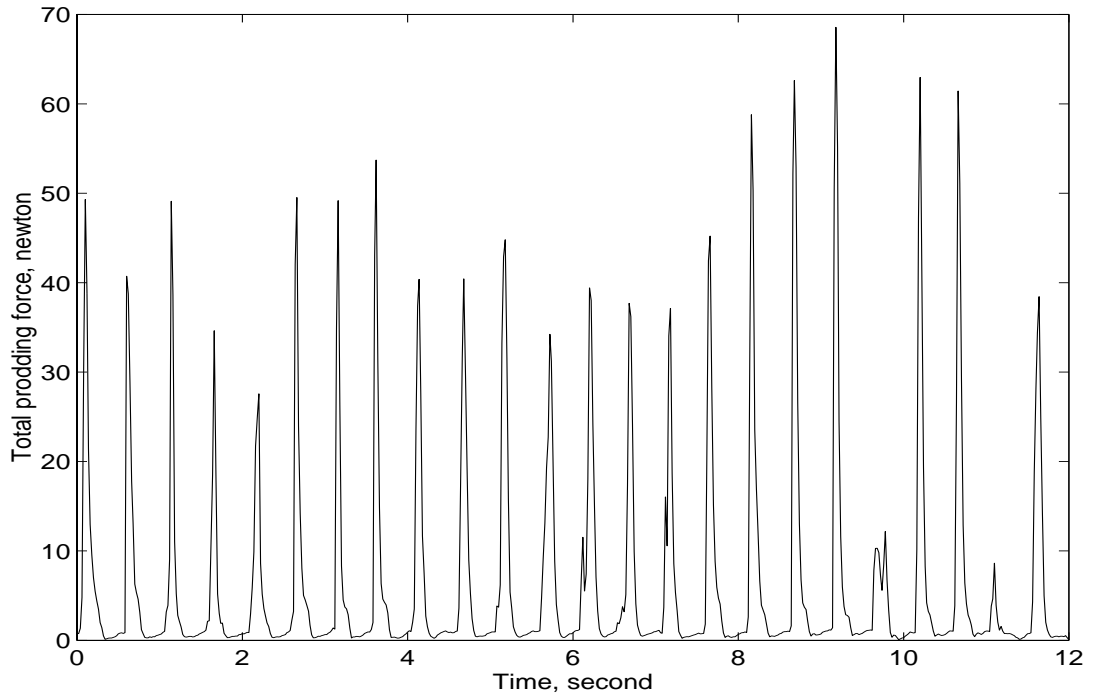

Figure 5.12: Typical sample of prodding force data.

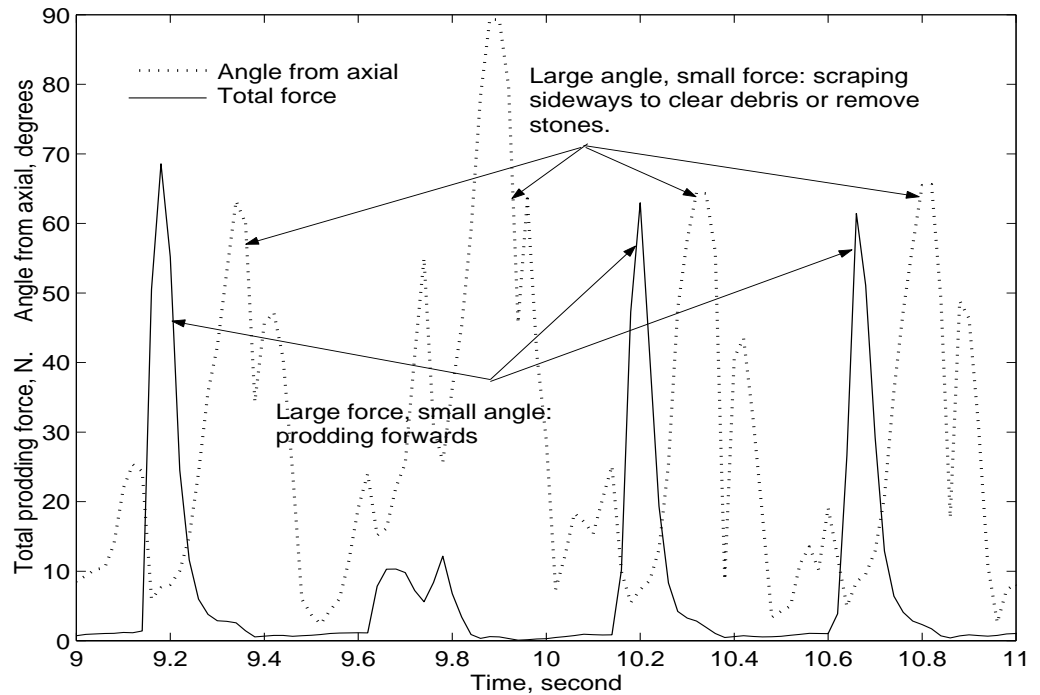

Figure 5.13: Expanded section of data in figure 5.12 with 'angle from axial' data added.

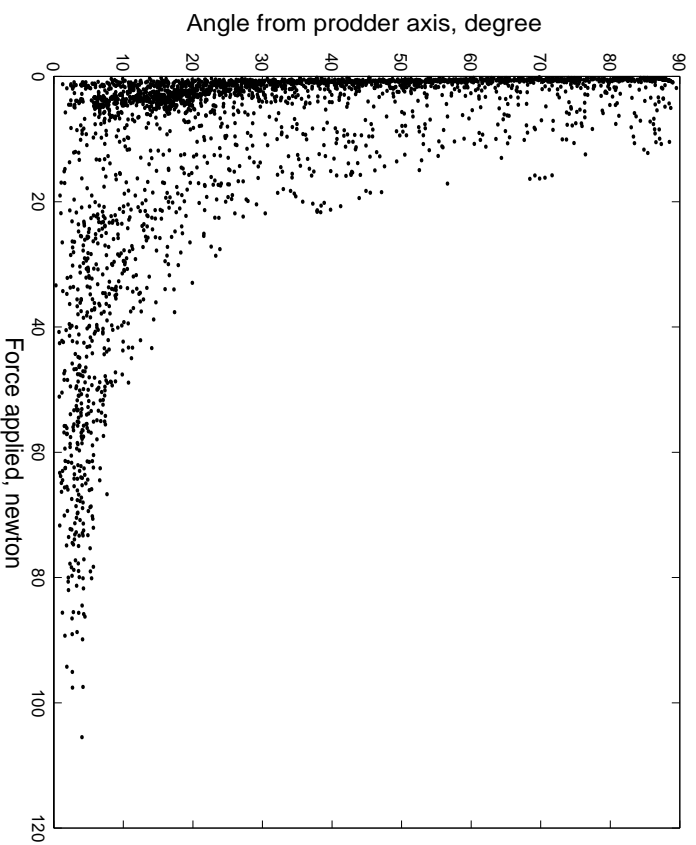

Figure 5.14: Scattergram of angle of applied force from axial vs. magnitude of force.

The number of peaks in each 5 N band was calculated as a percentage of the total data. These cumulative percentages were plotted against the magnitude of the peak force, to give a graph of the percentage of prodding actions below a certain value of peak force. The result is shown in figure 5.15.

Discussion of results of measuring the force used while prodding

Figure 5.15 shows the typical shape of the cumulative probability curve of a random process, so the peak force used during prodding can be considered to be largely random within the range specified. The remarkable similarity of the data between Afghanistan and Pakistan cannot be explained without further research and may be a coincidence, or it may be that this was a comfortable force for many people and deminers habitually use a similar force while excavating.

The force used during the digging of the initial trench away from the target was clearly shown to be larger than the subsequent careful exploration; this is included for comparative purposes and the force used during the initial digging is not suggested as posing a safety hazard. Several deminers expressed anxiety about the possibility of damaging the force measuring prodder while cutting the trench so these data probably underestimate the force normally used.

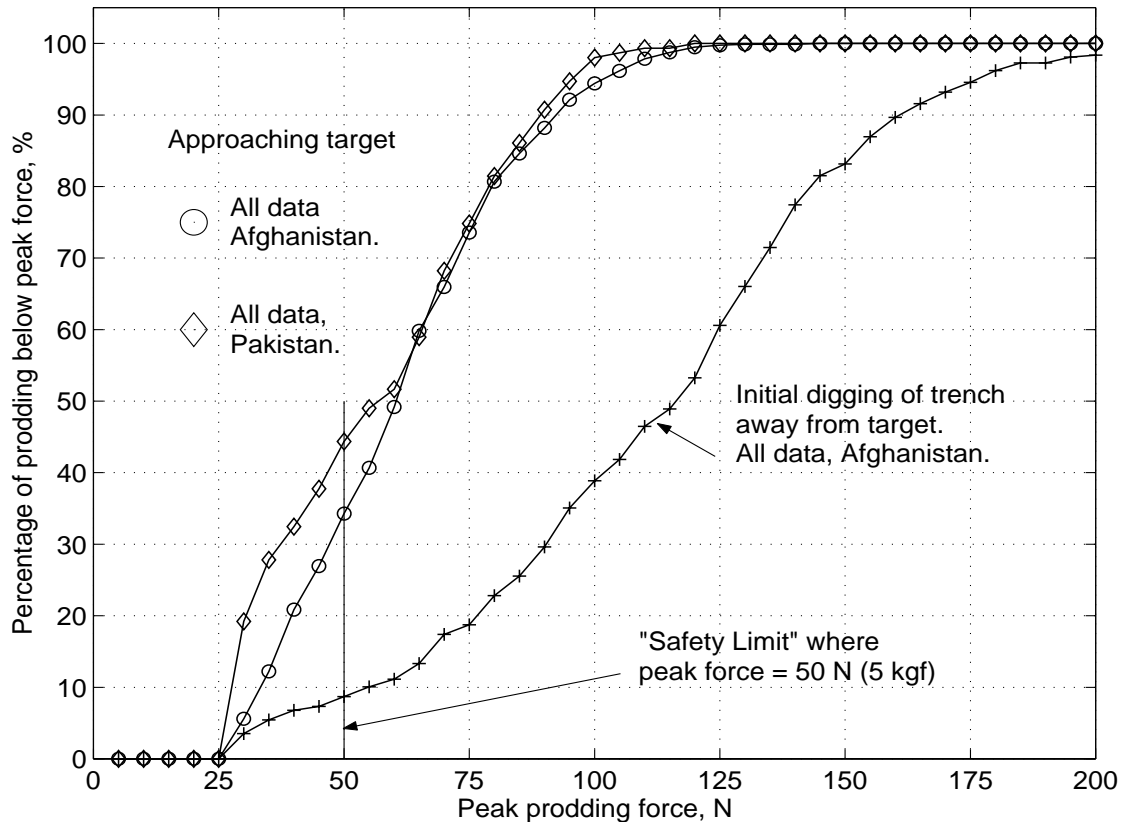

Figure 5.15: **Percentage of prodding below a certain peak force, vs peak force.** Data sorted in increments of 5 N for all peaks above 25 N.

These results clearly show that deminers are pushing hard enough to detonate many types of anti-personnel mines while excavating. In Afghanistan only about 34% of the prodding while closely approaching the target had a peak force of less than 50 N (5 kgf), in Pakistan this rose to about 44%. In both countries about 50% of the prodding close to targets used peak forces of over 60 N, and the highest peak forces were about 125 N (12.5 kgf). The occasional peak force of 100 N or more may be enough to transmit sufficient force to detonate some mines through a covering layer of soil and stones, before the deminer is fully aware of the mine's exact location.

Human factors in determining prodding force used

Interviews with Afghan deminers participating in the research suggested that many of them believed they were using half, or less, of the actual measured force. There is thus a need for improved training of deminers in the "feel" of a particular force (see also section 5.8 below) as well as a need for better tools that penetrate hard ground more easily.

The style of prodding strongly affected the peak forces measured; a rapid stabbing action, using the point of the prodder to penetrate, produced peaks of short duration but large magnitude. One Afghan deminer in particular used lower peak forces than anyone else. His action was to slowly press the tip of the prodder into the ground and loosen pebbles with a slow twist of the wrist. It may be relevant that he was participating in the trial during a break while working as part of a survey team and had spent the previous three hours on duty, including excavating targets in a live area. (Later the same day, after participating in the research, he successfully exposed a mine located by a dog). The effect of knowing an area to be safe, and perhaps wishing to impress an observer with a dynamic style of working, may have influenced some deminers despite requests that they work normally and especially that they use their customary force while excavating.

5.5 Laboratory work developing rotary prodders

A programme of research into improved prodding was established with a view to investigating how to insert prodders into hard soil using low force at reasonable speeds of penetration.

5.5.1 General specification for demining tools

The basic specification for any humanitarian demining tools for use in remote areas in poor, heavily mined, countries might well include such general statements as:

- The tools must be: cost-effective, reliable and safe.
- Using the tools must offer an advantage in speed of clearance in proportion to the cost of the tools (both capital and operating cost).
- Any failure modes (including batteries discharged in normal use) must not endanger the operator.
- Use of the tools must be sufficiently intuitive that safety and utility do not depend on remembering complex operating instructions.

A simple low-power rotary prodding system was chosen for further investigation as it meets many of these criteria.

5.5.2 Rotary Prodders

A standard masonry rotary-drill bit (or concrete drill bit) usually has a blunt trapezoidal tip made from a hard material such as tungsten carbide. Debris removal is by a helical flute, which works well when the drill is near the horizontal. These bits penetrate bricks well, especially if used with some percussive force as well as rotary movement, but are very poor at drilling through wood and other tough or fibrous materials. This differential in ability to penetrate different materials suggested that a rotary prodder with a similar tip might be able to penetrate soil much more readily than mine casings.

A test rig was constructed consisting of a lightweight trolley running, with low friction bearings, on a pair of rails inclined at 30 degrees to the horizontal to replicate the standard prodding angle used by deminers. Prodding systems under test were mounted on the trolley which was nearly counterbalanced by a weight attached to a light flexible cord running over a pulley at the top of the ramp. An optical shaft

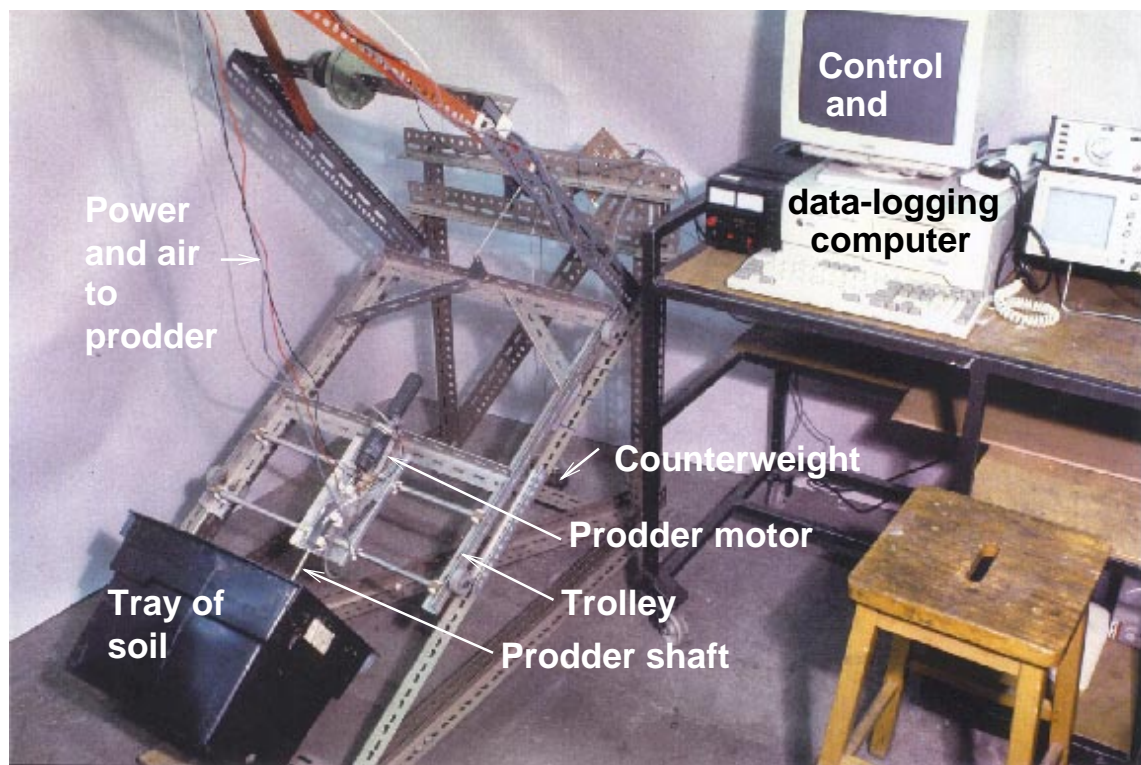
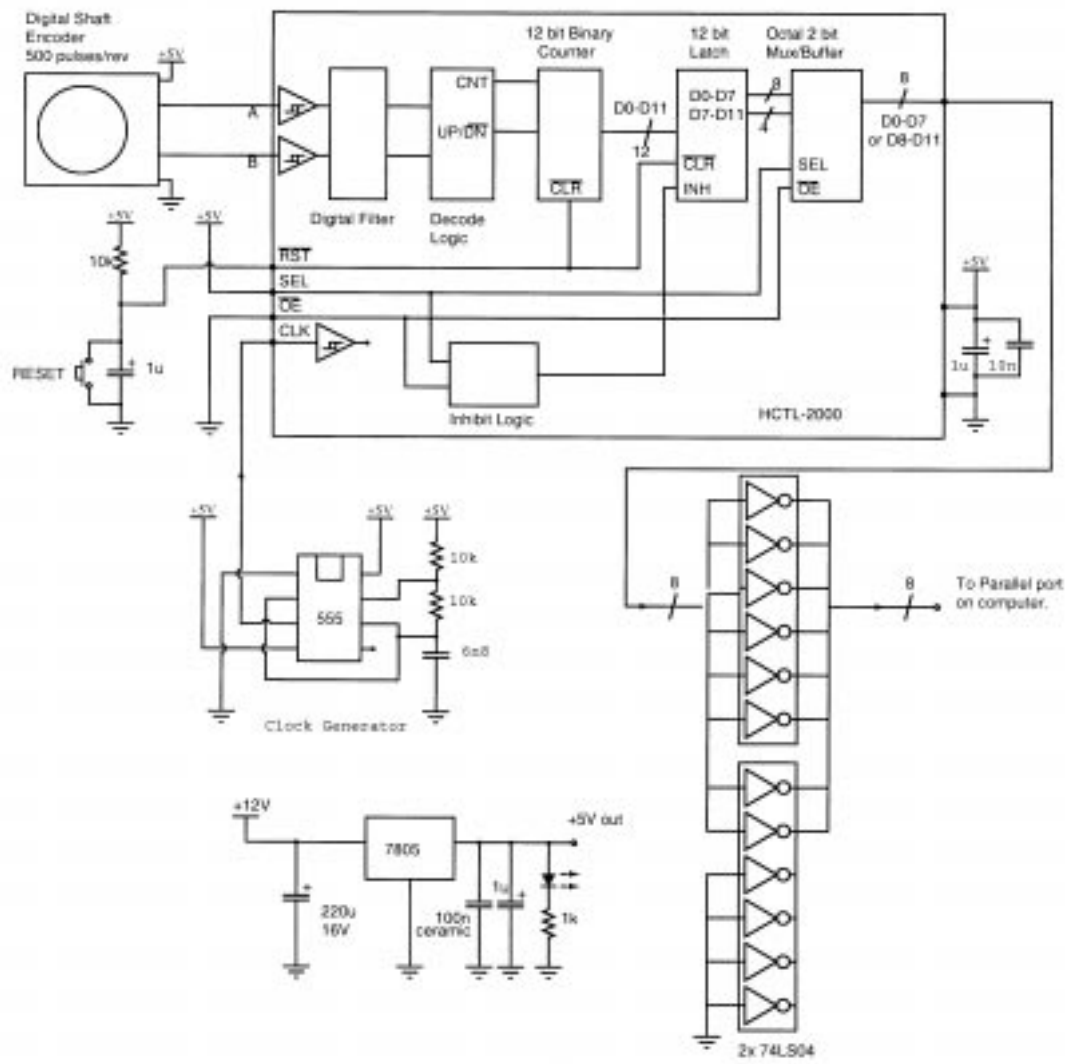

Figure 5.16: Test rig for measuring penetration of rotary prodders.

encoder coupled to the pulley was used to measure the position of the trolley on the ramp with a precision better than ± 0.2 mm. The counterweight was adjusted to give a constant force down the ramp of 5 newton along the axis of the prodder. This is more than an order of magnitude less than the force commonly used by deminers prodding hard soils, and is generally insufficient to detonate AP mines. Figure 5.16 shows a photograph of the equipment, figure 5.17 shows the circuit diagram of the rotary encoder and interface used, and a photograph of the assembled circuit.

At the foot of the ramp, trays of test soils were placed. The first soil type used, Soil A, was very friable and homogeneous, being a builders' sand with a high proportion of fine particles; 11 % by weight passed through a $63 \mu\text{m}$ sieve, 25 w/w% passed through a $212 \mu\text{m}$ sieve. This sand was put in deep plastic trays and the trays were flooded with water and shaken well to expel trapped air, then slowly baked at 110°C to complete dryness. The resulting hard pan was completely impenetrable to a conventional demining prodder, and extremely difficult to excavate with a trowel.

An experimental prodder was made by silver-soldering the triangular tungsten carbide tip of a lathe tool to a 5 mm diameter stainless steel tube 300 mm long. The tip was ground down until it was 2 mm wider in total than the tube diameter, and an air passage was left open from the tube around the tip. The tube was attached to a stepper motor to allow precise rotation and reciprocal rotary movement under computer control. The stepper motor had low inertia so the motion was not smooth



Optical shaft encoder interface circuit

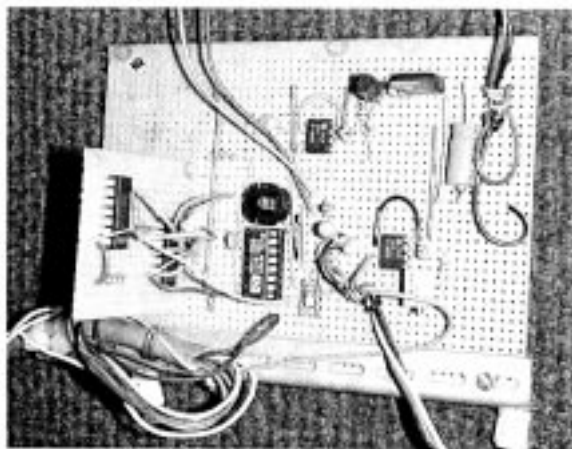

Figure 5.17: Circuit diagram and photograph of shaft encoder interface.

at low speeds. Compressed air, after passing through a pressure regulator and flow meter, could be introduced at low pressure into the prodder, and emerged on either side of the tip to blow debris clear.

The rotation of the prodder and its penetration were recorded by the computer controlling the rotation; an interface circuit presented the data to four parallel ports installed in the computer, where it was read by a program written by the author in Basic; Appendix ?? contains the program listing.

Low-speed Reciprocal Rotary Prodding.

The investigation of low rotary speed relatively shallow prodding (100 mm deep) using the stepper motor demonstrated:

- (a) penetration with a force of only 5 N was possible within certain constraints.
- (b) unless the debris from drilling was effectively removed from the hole the prodder would usually jam before penetrating 50 mm. A flow of low-pressure air of 5 litres per minute was found to be sufficient to blow all the debris out of a hole of up to 100 mm penetration.
- (c) provided the debris was removed, and there was no significant contact between the tube and the side of the hole, there was no significant change in speed of penetration with depth.
- (d) The speed of penetration was nearly linearly related to the speed of rotation of the prodder in the range 15 to 180 rpm. This relationship is shown in figure 5.18.
- (e) Reciprocating motion (either half a turn then reverse or a full turn then reverse) gave slightly faster penetration than continuous unidirectional rotation, but the difference was small.
- (f) The prodder was unable to penetrate thin plastic sheet (1 mm 'polystyrene' of unknown grade and hardness). After 10 minutes only a small indentation had been produced in the surface of the plastic.

Fast Unidirectional Rotary Prodder.

The maximum penetration rates obtained using the stepper motor were about 2 mm per second, for a rotational speed of three revolutions per second (180 rpm). The

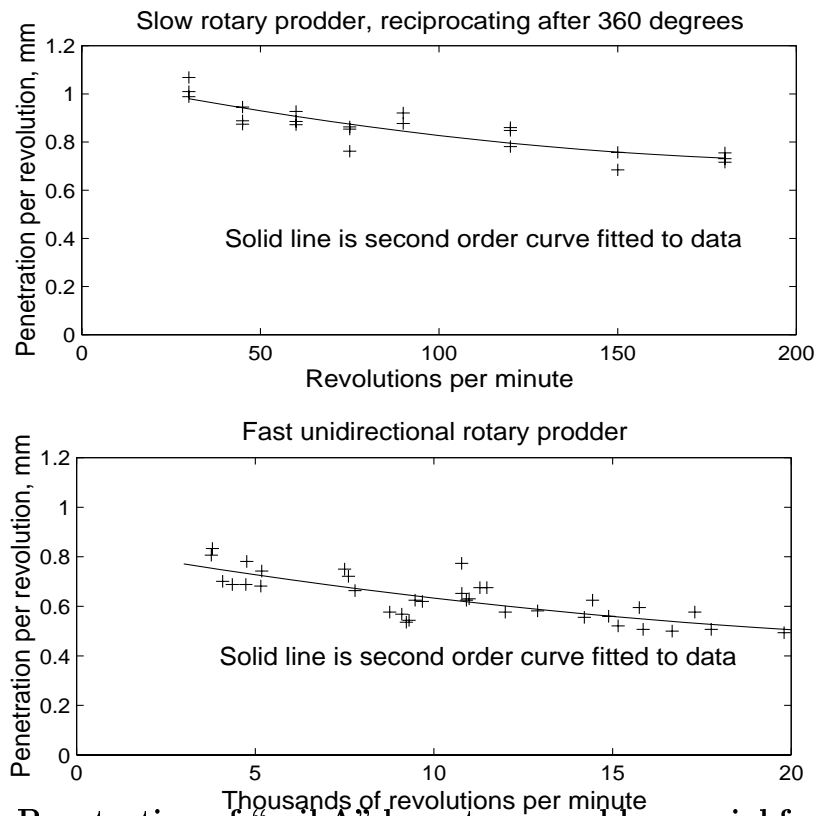

Figure 5.18: Penetration of "soil A" by rotary prodders, axial force = 5 N.

need for faster penetration rates led to the development of a prodder capable of rotating at over 18 000 rpm (300 revolutions per second), based on a cheap (£4) low voltage motor used in electric-powered model cars. Despite the considerable advantages of a reciprocal motion in terms of locating sensors in the prodder, a unidirectional design was chosen to allow higher rotary speeds.

Further experiments showed that the nearly linear relationship between rotational speed and penetration speed continued up to the maximum rotational speed of this motor (figure 5.18); using a linear approximation, the correlation coefficient between rotational speed and penetration speed was 0.96 in the range 3 000 to 20 000 rpm. At the highest speeds penetration rates of over 150 mm per second were possible with an axial force of only 5 N. Comparison of the slow reciprocating motion with the fast rotation for the same prodder is limited by the difference in the motion and use of a different sample of Soil A. An increase of two orders of magnitude in rotational speed led to a decrease of only 50% in the penetration per revolution clearly suggesting that high speed rotary prodders offer one method for rapidly penetrating hard homogeneous soils. At all speeds the triangular-tipped prodder produced clean parallel sided holes, as can be seen in the photograph in figure 5.19.



Figure 5.19: Block of “Soil A” sectioned to show clean parallel holes produced by rotary prodder.

Disadvantages of high speed rotary prodders

This high speed prodder did however have some important disadvantages.

- When hand-held the vibration and noise generated made it harder to feel and hear the prodder tip in contact with a solid object, and the dust generated made close observation difficult. Dust is a particularly severe problem for deminers working prone as it irritates as well as blocking the view of the prodder. In this position a protective polycarbonate visor soon became coated with dust when using the prodder in trials.
- The frictional heating when the tip was in contact with polystyrene was sufficient to melt the plastic and eventually allow the prodder to pass through the 1 mm thick sheet after about 20 seconds. This time is still ample to allow easy discrimination between a plastic cased mine and soil. The distinctive smell of melting plastic could be observed a few seconds before the prodder passed through the polystyrene sheet. Experiments with a modified domestic smoke detector costing £5, connected to an air-sampling system, demonstrated that

the alarm could be reliably triggered in less than one second when sampling the air from around the melting plastic. This could form the basis of a sensing prodder capable of detecting plastic mine cases by heating and vapour sampling.

Under the test conditions (5 N force, sufficient airflow to clear debris, Soil A) the fastest entry time for 200 mm axial penetration was under 2 seconds, which is more than fast enough for manual demining. The limiting factor for use in real soil was the presence of small objects (stones, debris, roots) which the prodder could not readily penetrate and which caused it to jam.

A second, non-homogeneous, test soil, Soil B, consisting of 40 % small gravel from 2 mm to 20 mm in size, 15 % kaolin and 45 % by weight of the builders' sand was prepared in the same way as Soil A. The triangular bladed prodder was unable to penetrate this sample well; the flat blade always became trapped between two gravel particles and stalled.

As the depth of penetration in Soil A increased, the airflow required to clear all small-particle debris from the hole also increased. At 200 mm penetration between 8 and 10 litres per minute were required. Pulsing the airflow to produce short bursts of movement offered one way to reduce overall air consumption and also to increase the clearance of debris from the hole. Provision of a compressed air supply in the field is not easy; generating sufficient volume of air even at low pressures requires considerable energy input.

Power consumption of the motor of the fast prodder was typically in the range 30 to 50 watts while drilling. Whilst this is more energy use than is desirable, a deminer using the prodder for 50 % of the time during a half-hour active shift would require a standard rechargeable battery weighing about 600g and costing about £16.

Power required to compress air

The energy required to compress air can be calculated for the isothermal and adiabatic cases [Bar97]; in the former the temperature of the air does not change during the compression, in the latter there is no heat transfer between the gas and its surroundings.

i) *The Isothermal case.* Since $PV = nRT$ (Universal gas equation), and T is constant it follows that $P_1V_1 = P_2V_2$ and the work done in compressing the gas is given by:

$$W = \int_{V_1}^{V_2} P dV = \int_{V_1}^{V_2} \frac{nRT}{V} dV = -P_1V_1 \log_e \left(\frac{P_2}{P_1} \right)$$

ii) *The Adiabatic case.* The governing equation is: $PV^\gamma = \text{constant}$; hence $P_1V_1^\gamma = P_2V_2^\gamma$. For diatomic gases $\gamma = 1.4$; since air is comprised almost entirely of the

diatomic gases nitrogen and oxygen, gamma can be taken as being 1.4 for air. The work done in compressing air adiabatically is thus given by:

$$W = \int_{P_1}^{P_2} V dP = \frac{\gamma}{\gamma - 1} nRT_1 \left[\left(\frac{P_2}{P_1} \right)^{\frac{\gamma-1}{\gamma}} - 1 \right] = \frac{\gamma}{\gamma - 1} P_1 V_1 \left[\left(\frac{P_2}{P_1} \right)^{\frac{\gamma-1}{\gamma}} - 1 \right]$$

Contour plots for the power required to compress air are shown in figure 5.20. Delivering 20 litres/minute (0.33 l/s) FAD of air to a prodder at a gauge pressure of 2 bar (absolute pressure of 3 bar) requires 36 W for isothermal compression and 42 W for adiabatic compression; in practice the power required will be between these two figures or about 40 W. This is the power delivered to the uncompressed gas and must be divided by the efficiency of the compressor, probably less than 70% for a small compressor, to obtain the power needed from the battery in a portable system. This is about the same as the rotary power used by the prodder motor, and is a constraint on this use of compressed air in remote locations.

The requirements for compressed air and rechargeable batteries are definite steps away from the goal of simple and inherently extremely reliable equipment and would pose logistical problems in some mined areas in remote locations.

Alternative rotary tip for better penetration of gravel

In an attempt to improve the penetration of soils with gravel, the tungsten carbide tip was replaced with with a small wire-brush made from 24 gauge (0.56 mm) piano wire parallel to the axis of the main shaft. This had been found to be effective in penetrating Soil A though the resulting rotational friction was higher than when using the carbide tip, and axial penetration speeds were 25 % to 50 % slower. To reduce the power consumption of the motor the penetrating force of the prodder was reduced to 3 N; satisfactory penetration was still obtained to a depth of over 200 mm at axial entry speeds about 40 % lower than for the triangular-tipped prodder and the resulting hole was about 2 mm larger in diameter.

The wire brush was able to loosen and separate the gravel particles in Soil B. An airflow of 8 l/min kept the dust and sand out of the hole, but was not able to lift out the gravel. If a wider hole were excavated by moving the prodder from side to side, the gravel could be removed by hand or with a small long-handled scoop. Penetration to depths of over 80 mm was achieved during the first trials. This tool had a number of problems:

1. A large amount of dust was produced.
2. There was very rapid wear of the wires of the wire brush, as much as 15 mm while penetrating 80 mm.

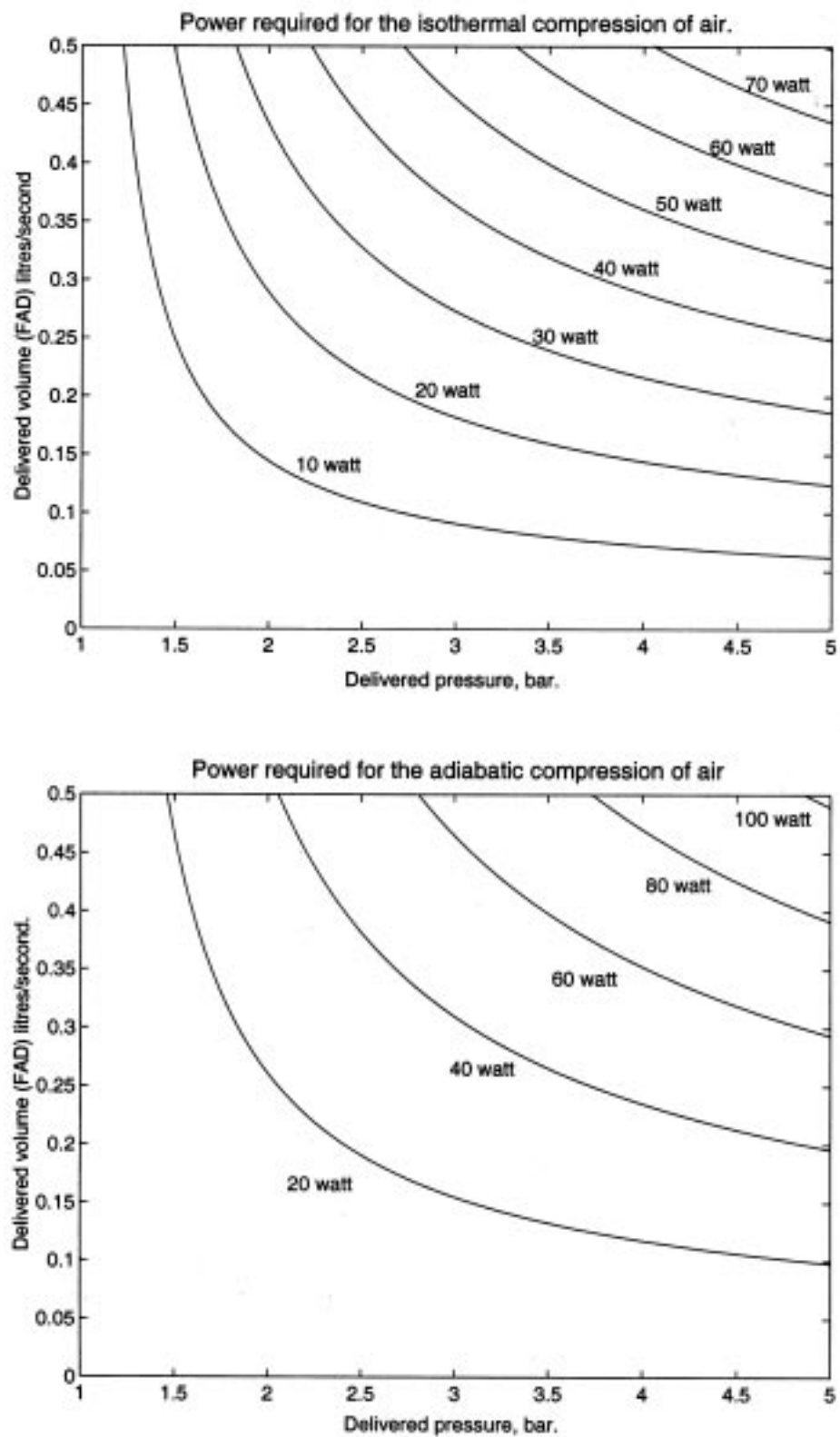

Figure 5.20: Contour plots of power required to compress air isothermally and adiabatically. Note: Pressure values are absolute and not gauge pressures.

3. Small pieces of the piano wire broke off from the brush, leaving tiny pieces of scrap metal in the area being excavated. These might be sufficient to register with a metal detector but would be extremely difficult to find.
4. There was severe vibration at the handle.

However, a lightweight, wire brush on the end of a short or medium length low-power rotary prodder might offer a potential alternative to pickaxes and scraping hard with a trowel for loosening tightly packed gravel. It may be possible to remove the dust produced by suction to improve visibility during operation. The experiments suggest that even the most compacted rocky soils, provided that they are dry, can be effectively excavated by this means without using more than 5 N downwards force on the prodder at any time. For some environments this could be a potentially useful tool.

5.6 Field testing of rotary prodders in Cambodia

5.6.1 Equipment used

Two rotary prodders were designed and constructed for field testing; details of their specification are in figure 5.21; figure 5.22 shows a photograph of the prodders and associated equipment. One of the prodders had an exposed rotating main shaft made from stainless steel tube, the other had a stationary outer sleeve covering the rotating shaft; these were named “unsleeved” and “sleeved” prodders respectively. The unsleeved version of the prodder is simpler and more robust; providing a bearing close to the tip of a sleeved prodder is technically demanding as it must

- (i) have a low profile,
- (ii) function with low friction in a dusty environment at high rotary speeds (in excess of 10 000 rpm) and
- (iii) support large lateral forces without damage when the prodder is used for excavating.

For the prototype sleeved prodder a pair of miniature sealed ball races were used for the tip bearing; it was noted that these had been manufactured in Thailand and imported into Britain so they would probably be available throughout Southeast Asia, including Cambodia. Figure 5.23 shows details of the tip of the sleeved prodder and figure 5.24 shows a general assembly drawing.

Before field testing it was unclear whether unsleeved hand-held prodders would have too much contact between the rotating shaft and the sides of the hole to be able to function adequately.

PRODDERS

- The shaft of each prodder is approximately 300 mm long.
- The prodder handle consists of two parts screwed together: the rear part is 35 mm diameter and 100 mm long and contains the air valve and connections for air and electrical power and control. The front part is 35 mm diameter and 170 mm long (sleeved prodder) or 190 mm long (unsleeved prodder), and houses the motor drive, bearings and force detection circuit.
- The two parts of each prodder handle are easily separable, the air valve is identical on both designs. The air valve is constructed from a small solenoid and a neoprene ‘O’-ring seal to give low power operation and minimal pressure loss at flow rates up to 20 l/min.
- Total mass of prodder ready to use (including air valve) is 530 g sleeved, 525 g unsleeved.
- The shaft outer diameter is 10 mm sleeved, 8 mm unsleeved.
- The rotating tips are made from tungsten carbide, and are approximately 1 mm wider than the shaft diameter.
- The motor is connected to the prodder shaft via a rubber coupling to reduce vibration.
- The air flow passes through the valve, through the motor body to cool it, and then down the shaft of the prodder to exit at the tip.
- The motor and air flow are controlled by a single low-profile push-button on the side of prodder handle; the switch position can be moved to suit the operator.
- The motor and bearing assembly is rubber-mounted to reduce vibration and permit the use of an over-force measuring system to detect when the operator exceeds a preset maximum force.
- The prodder can be quickly connected or disconnected from the air and power supply in the field.

AIR & POWER SUPPLY AND CONTROLS

- A standard air compressor is used with a single stage pressure regulator designed for LPG delivery systems; the output pressure is adjustable from zero to three bar (0–300 kPa).
- The electric supply uses a standard 12 volt rechargeable lead acid gel-cell battery.
- The control box has the following features:
 - Pulse-width modulation control of the motor by a power FET for very high efficiency.
 - Maximum torque (peak current), and no-load maximum speed of rotation (no-load voltage) of the motor are independently controlled and separately adjusted.
 - An ammeter to monitor the motor current is located on the control box.
 - Over-force detection can be selected to turn off the motor and air supply, sound an alarm, or both, when a pre-set prodding force is exceeded.
 - The motor automatically “soft-starts” with controlled torque at switch-on.
 - The motor is automatically switched off if air pressure is lost.
 - The air valve can be set to be continuously open or pulsed at an adjustable frequency up to 7 Hz, when the motor is running. The pulse rate can be linked to the motor current to increase the airflow when the prodder is meeting more resistance.
 - A flexible two-metre long “umbilical cord” connection provides power, control and air to the prodder.
 - There is an output to permit monitoring of the motor’s speed.
 - The control box is robustly constructed for field use.

Figure 5.21: Specification of rotary prodders field tested in Cambodia.

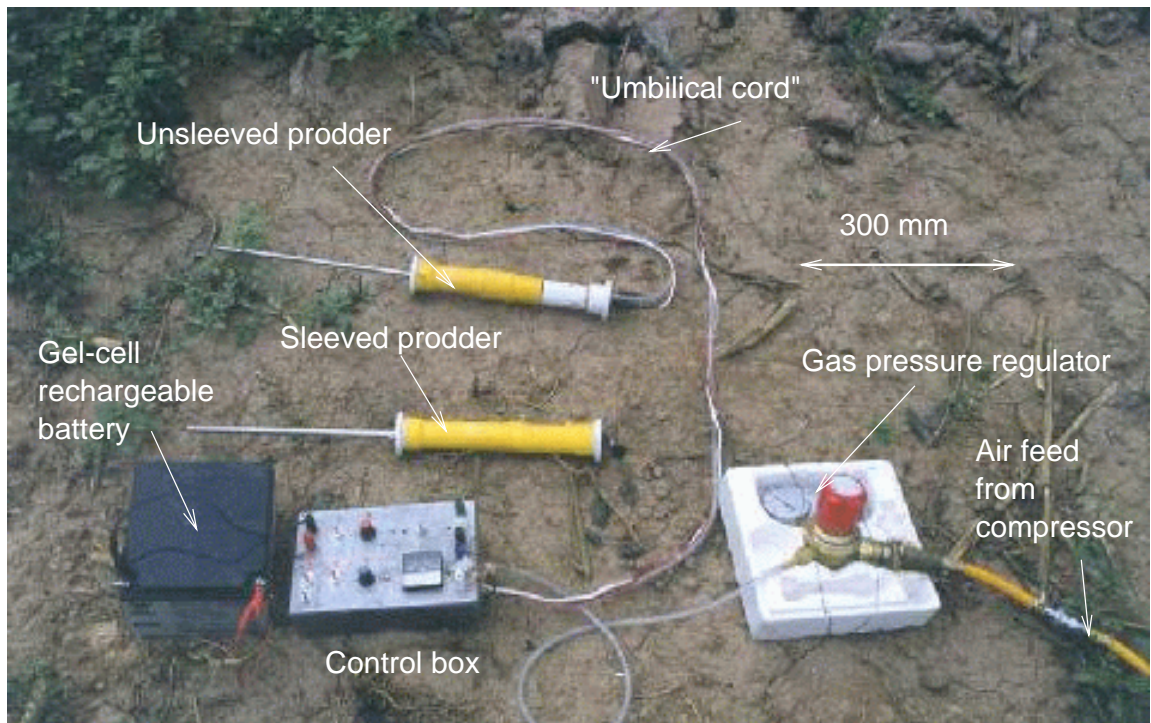

Figure 5.22: Rotary prodders field tested in Cambodia.

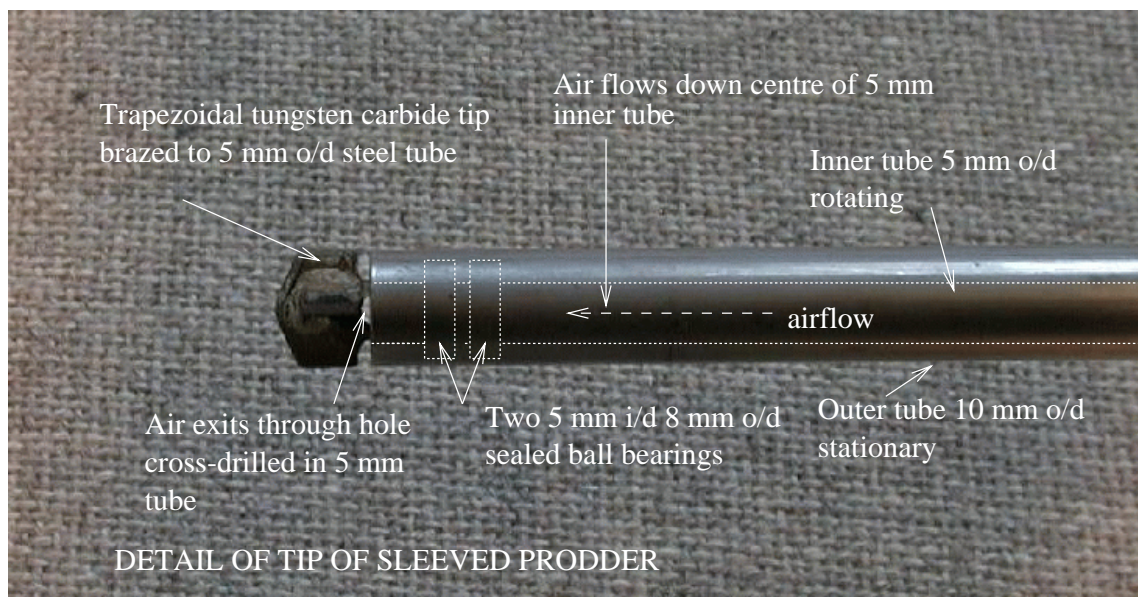
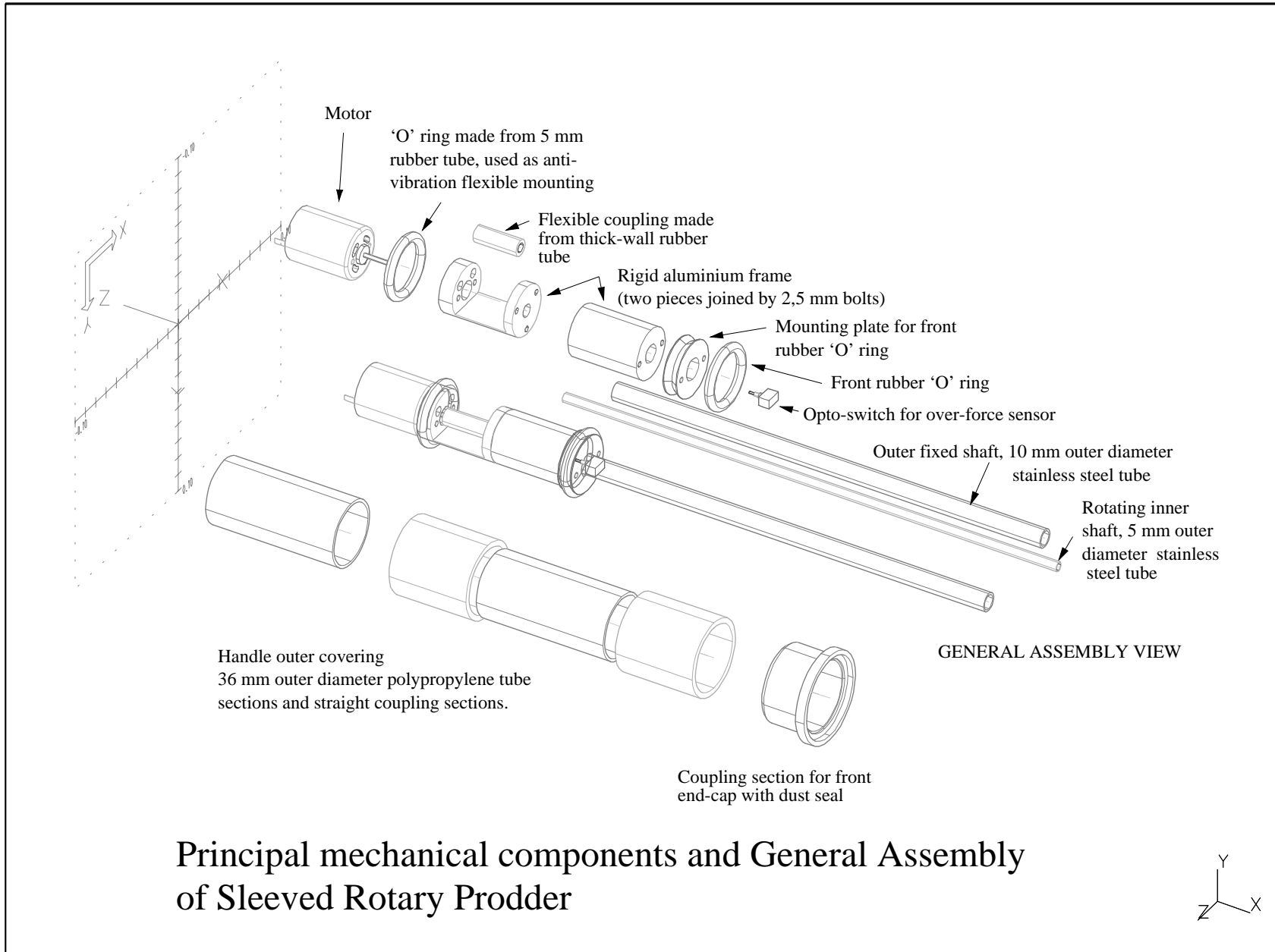

Figure 5.23: Detail of tip of sleeved prodder.

A considerable amount of work was also done on analysing the airflow required to clear debris from the hole made by the rotating low-force prodders to prevent them jamming, and how best to provide an adequate amount of pressurised air in the field (see section 5.5.2). In the end a standard “2-horsepower” electrically powered workshop air-compressor and a long air-hose were purchased in Cambodia.

Figure 5.24: General assembly of sleeved prodder.



A liquid petroleum gas (LPG) regulator set was used to reduce the air pressure to between 1 and 2 bar for delivery to the prodder through a small diameter polythene tube. It is acknowledged that this is not an ideal solution for working in mined areas, but the need to test the prodders with a sufficient flow of air to determine their other characteristics led to the airflow problem being set aside for future investigation.

Both prodders incorporated identical, specially designed, solenoid valves to control the airflow, and to allow pulsing of the air at up to about 7 Hz. Pulsed airflow reduced air consumption while increasing the debris clearance effect, though it produced a “chuffing” noise which was found to be distracting by some deminers.

The motor drive for rotation had both voltage and current regulation, each independently adjustable, in a control box which fed power to the prodder via an “umbilical cord” of wires attached to the air tube. The voltage adjustment gave control of the maximum rotational speed when unloaded, to avoid resonance effects, and the current adjustment controlled the maximum torque when drilling. The control box also incorporated an ammeter, the over-force warning circuit which stopped the motor and airflow when the operator pushed too hard, and the pulse drive for the air valve.

Figure 5.25 shows the electronic block diagram of the control box.

Both prodders had flat trapezoidal tips made from the tungsten carbide tips of standard masonry drill bits. These were ground down to give an overhang of the width of the shaft of about 0.5 mm on each side to reduce the power and airflow required during drilling.

After assembly the prodders were tested near the Cambodian Demining Workshop in Phnom Penh. Four different soil types were available:

1. Light silty soil with vegetation (a mixture of wild bushes and weeds, and cultivated areas). This was hard and dry at the end of the dry season, and packed hard where a footpath crossed the land.
2. Heavy clay soil/subsoil that had been used to landfill.
3. Compacted soil used to build the base for a road, essentially similar to a compacted mix of the first two types.
4. Stony lateritic soil used to surface a road, highly compacted and very hard. Embedded “gravel” particles were from 1 mm to 30 mm diameter, mostly between 2 mm and 10 mm, irregular in shape but with well worn corners and edges. Due to flooding in the rainy season many roads in Cambodia are built on dykes from 1 m to 5 m high, with a thick layer of compacted laterite at the top. This laterite has a high iron content and a lot of small and medium

Figure 5.25: Block diagram of the prodder control box.

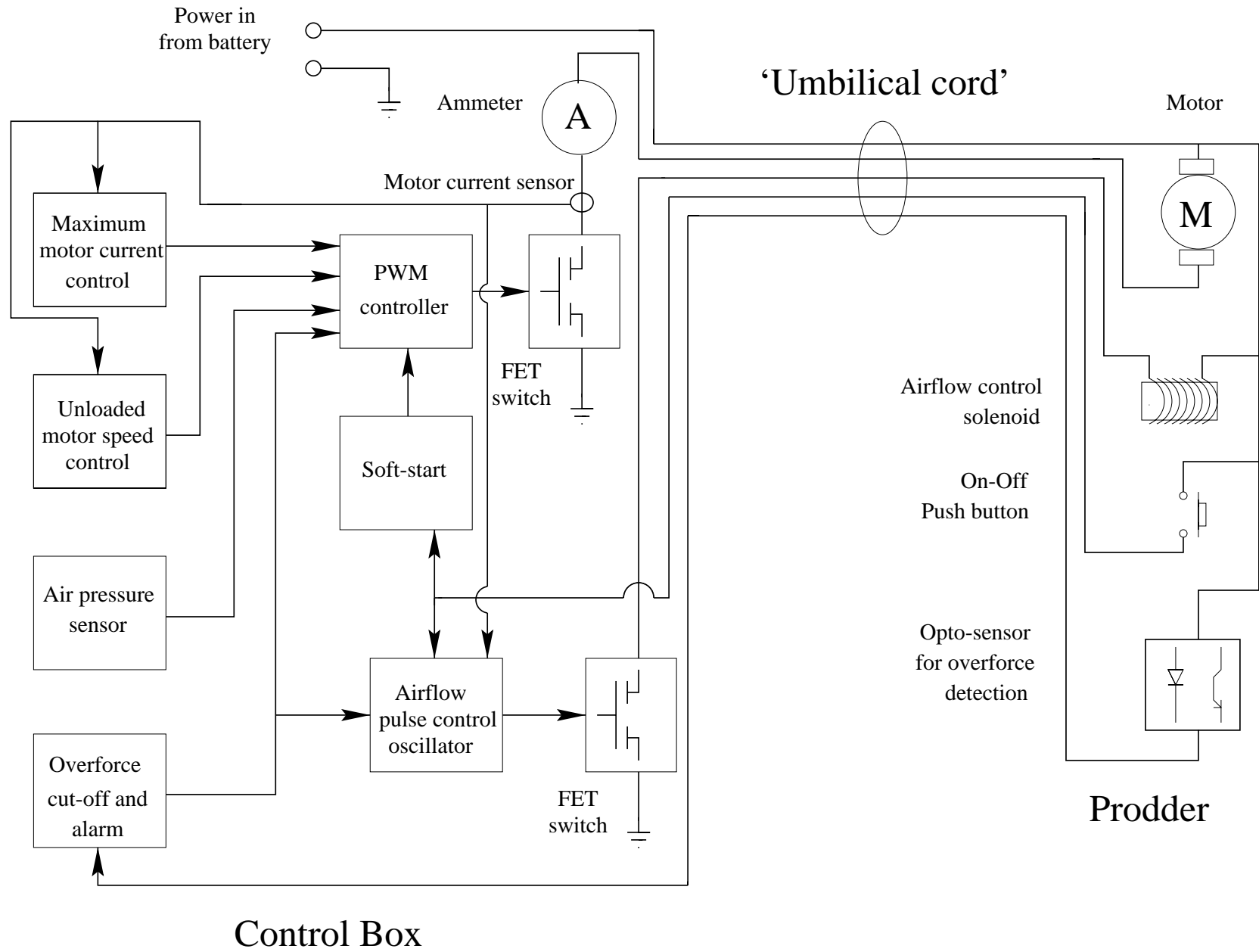

gravel; it compacts to a highly impenetrable layer. Hence, metal detection to find mines in roads is very difficult and excavation painfully slow.

Once the rotary prodders were ‘run-in’ to bed down the motor brushes and bearings the current drawn from a nominal 12 volt lead-acid battery was about 1 amp at a rotational speed of over 10 000 rpm when operated in air. During testing the current limit was set to 6 amps. Typical power consumption at this current was in the range 40 to 50 W.

5.6.2 Results of testing rotary prodders in Cambodia

Penetration of the sample soils was not as good as had been hoped for.

1. The light silty soil presented few difficulties but penetration was slower than the sand/silt mix in the laboratory at Warwick University had been. Penetration of the 300 mm length of either prodder required over 20 seconds. The motor torque was inadequate to keep the prodder turning if faster penetration was attempted. Increasing the maximum torque by raising the current limit to 8 amps gave slightly faster penetration but was at the power dissipation limit of the motor used. The increase in torque required when changing from the unsleeved prodder which produced a hole about 9 mm in diameter (cross section 64 mm^2) to the sleeved prodder which cut a larger hole about 11 mm in diameter (95 mm^2) led to the unsleeved prodder always having faster penetration and being less inclined to stall. In this type of homogeneous soil there appeared to be no need for an outer stationary sleeve if the operator was careful not to touch the prodder shaft against the side of the hole.

However, this penetration rate was still very much quicker than manual excavation and prodding with existing tools, and this result was encouraging.

2. The heavy clay soil was very difficult to penetrate. Injecting water into the airflow through the prodder was tried as one way of improving penetration in this soil, but made little difference. The water did significantly reduce the amount of dust generated by the prodders and this is potentially useful if the other problems can be resolved. The water was introduced into the airflow at the upper end of the prodder shaft by means of a crude carburation system based on a hypodermic needle. This produced a cloud of water droplets in the air and consumed water at a rate adjustable between about half a litre and two litres in ten minutes.
3. Very slow penetration rates were achieved in the highly compacted soil. This soil is also extremely difficult to prod and excavate by conventional means. As

with all the tests, the noise of the prodder and the pulsating airflow made it difficult or impossible to hear the tip scraping against buried objects.

4. In the laterite road bed the rotary prodders acted quite effectively as excavation tools and were able to loosen the highly compacted surface though unable to drill in due to the presence of large amounts of gravel. The action of excavating relied on the tip loosening embedded gravel and pushing it clear, but in doing so the tip bounced around and threw small particles of gravel to both sides. Penetration as a prodder was not possible.

A small amount of work had been done at Warwick University on different tips to rotary prodders to better excavate this type of compacted gravel (see section 5.5.2). It was found that a wire brush made of just two or three strands of piano wire was quite effective but wore down very quickly and small pieces of the wire tended to break off. This depositing of metal particles had been thought unacceptable, but staff of one of the demining organisations in Cambodia pointed out that this type of metal contamination is so common in minefields, and the problem of excavating laterite roads is so severe, that it might well be a penalty worth paying.

The tip shape of the unsleeved prodder was altered by grinding and it was found that removing the centre to leave a crude trepanning tool gave slightly improved penetration of the softer soils, though the difference was small and the modified tip tended to wander before cutting into a hard surface.

5.6.3 Deminer reaction to rotary prodders

The initial technical testing had shown the prodders to have some important drawbacks. The effect of hitting rocks or plant roots could be clearly felt by the operator but the dust, noise and vibration generated in drilling were serious problems.

Despite these problems there was some interest in Cambodia in the rotary prodders and the whole concept of low-force drilling into hard ground. The technical advisory staff at Cambodian Mine Action Centre (CMAC) reviewed the rotary prodders. As expected, the idea of penetrating hard ground using 'safe' forces was appealing, and several of the features were commended. Of particular interest was the integral force sensing mechanism which provides the operator with a warning and turns off the motor and airflow in the prodder if too much force is used. This was found to have a design flaw which made it difficult to adjust the maximum force setting accurately when the air-flow was turned on, and changed the maximum force setting as the prodder entered the ground, so practical demonstrations of the force sensor were less than convincing. Despite this the concept was received with enthusiasm.

After these discussions it became clear that:

1. The prototypes needed to be considerably more refined before deminers could be expected to find them attractive.
2. The complexity and cost of the equipment and the need for a separate air supply were seen as great disadvantages. In a country where deminers earn USA\$150 per month it might be cheaper to spend more time or employ more deminers than to buy more equipment.
3. Rotary prodders were not liked by deminers because they increased what can be called the “excitement” of the work, and excitement is precisely what is *not* wanted while excavating a suspected explosive item. Noise, vibration, and dust all mask the very subtle “feel” that deminers use when excavating. Even a quiet noise can mask the slight difference between the sound of a metal tool gently touching a stone, a plastic mine case, or a metal UXO or mine case. A small vibration can mask the very subtle difference in feel between tapping these three items, and deminers are apparently accustomed to relying on this feel. Objectively, there may be no additional risk (and probably less risk) from using a rotary prodder as the force required to penetrate hard ground is less than for conventional tools, but unless deminers are comfortable with the tools they will be put to one side and left unused.
4. Deminers are in general extremely conservative in their choice and use of equipment. Neither deminers themselves nor donors want the risk of accidents during the testing of new equipment and prefer to stay with tried and trusted methods.
5. The most significant perceived need for a low-entry-force prodder in Cambodia was one capable of penetrating the laterite road-beds. However, considerable further work on the design of the rotating tip of the prodder would be needed to produce a tool capable of loosening tightly embedded gravel without causing an unacceptable amount of noise, dust and vibration.
6. Prodding as a means for primary detection is not common. The common method is metal detection and then a complex prod-excavate-look-listen-feel all at once. Rotary prodders do not allow this complex multi-purpose activity to proceed unimpeded.
7. There is a potential safety hazard in the event of accidental detonation of a mine/UXO by a rotary prodder; the component parts, especially the hard tip could become dangerous shrapnel and cause serious injury. This would need addressed by careful design and blast testing before using the prodders in a live area.

However, a substantial part of the lack of acceptance of the rotary prodders appeared to be due to subjective reasons. Some deminers appeared not to understand clearly why they were needed. By observing demining teams it became clear that, at least during the dry season, deminers routinely use much greater force to penetrate the ground during excavation than is required to detonate some mines. Even in the presence of both a local supervisor and senior staff, Cambodian deminers demonstrated techniques that included pressing hard enough to slightly bend a 6 mm diameter steel prodder yet described the soil as “not hard enough to need softening with water”. In the wet season the problem is much less severe in Cambodia.

A British deminer working as a Technical Advisor in Cambodia [Lar99] described the hard ground problem as nothing more than a nuisance which slowed down demining work by perhaps 20 % during the three or four driest months of the year.

5.7 Re-analysis of the original ideas

5.7.1 The difference between prodding and excavation

The original idea behind the research was based on information from deminers that a way of prodding in hard ground would be advantageous. However, what deminers really seemed to want is not a way to prod deeply into hard ground but a safe way to excavate it. A British deminer working as a Technical Advisor in Cambodia [McL99] explained his position as being “very suspicious of deep prodding in hard ground”, especially in the context of regularly, albeit infrequently, finding mines deliberately laid on their side. He was training Cambodian deminers in a technique of “gradual uncovering,” prodding to a depth of one or two centimetres and then scraping away the covering soil. To him excavation and prodding were synonyms for the one technique of gradual uncovering. In his view “tools for easy excavation of hard surfaces could be useful”.

Similar views were expressed by deminers in Afghanistan who used a similar gradual uncovering technique in stony soils.

Improved “prodding,” despite the name, appears to require an improvement to *excavation* rather than to penetrating deeply in hard soils.

5.7.2 Sensing prodders — is more information useful?

Several deminers with extensive experience in the field expressed the view that sensing prodders, while an apparently welcome extension to the demining toolkit, basically offered little to help the overall process of clearing hard ground. In the

end all targets found by metal detectors would be excavated anyway so that the ground was left ‘metal-free’ for quality assurance. A tool that gives information that a target is “almost certainly” a mine adds very little to the demining process; the target would have to be exposed by excavation anyway. Even when the target is known to be a mine the same procedure is followed; it has to be exposed by excavation to allow an explosive charge to be placed to destroy it. Clearly, there is little or no change to the working practice as a result of having more information about the target through the use of sensing prodders.

This perspective was presented to the humanitarian demining community world-wide for comment on the popular demining internet listserver network@MgM.org. The few comments received were supportive of the idea that the demining process does not greatly benefit from the information that a target is “almost certainly” a mine. The text of the listserver posting is in appendix A.

The same safety considerations outlined above (section 5.6.3) due to rotary prodders potentially creating dangerous shrapnel in the event of accidental detonation of a mine/UXO also apply to sensing prodders.

5.8 Force sensing prodders for training

During the field research work it became clear that there was room for improvement in the training of deminers in the estimation of the force being used while prodding. Unlike almost every other aspect of training, the use of excessive force cannot be detected simply by a supervisor observing the trainee. It is not suggested that deminers using existing tools will necessarily be able to excavate very hard ground without using more force than is necessary to detonate some mines, but that safety will be improved if they have a good appreciation of the magnitude of the force being used and the risks involved. If deminers think they are using perhaps 50 N but in reality are using more than double that force it seems reasonable to assume that the risk of accidental detonation is increased.

“Buzzing prodders” as a training tool

A low-cost training prodder was developed which sounded a small buzzer in the handle when the axial force exceeded a preset limit. Initially a piezo-electric “beeper” was used but this was changed to a buzzer to avoid confusion with the sound of many metal detectors. The force required to trigger the buzzer could be easily adjusted in the field with an Allen key from about 5 N to about 150 N (0.5 to 15 kgf). The prodder blade was mounted in an aluminium casting by two concentric shear springs

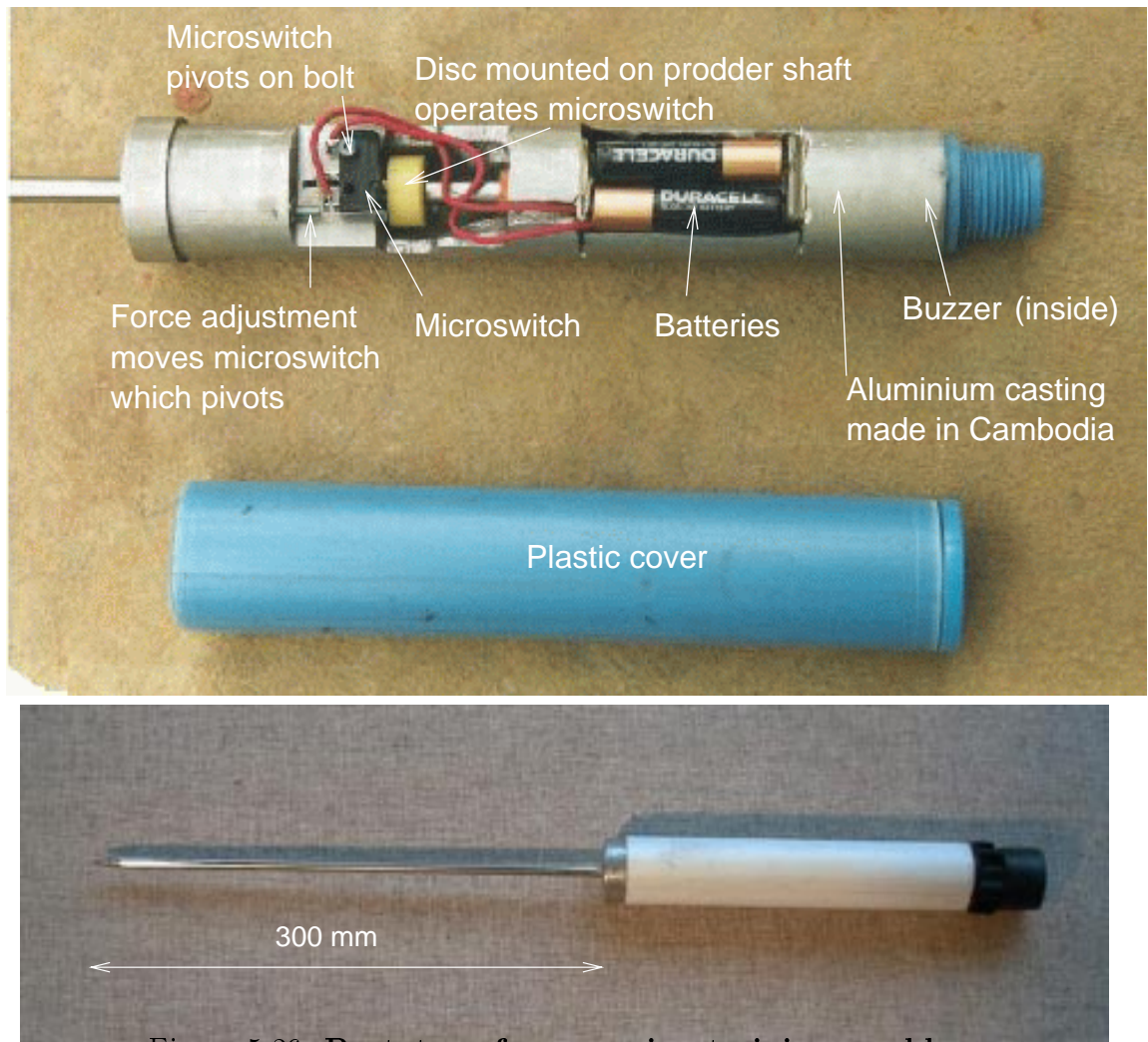

Figure 5.26: **Prototype force sensing training prodders.**

made from rubber tube; when pushed it released a micro-switch with a movement of less than 0.1 mm. The position of the micro-switch was adjusted to vary the force required to trigger the buzzer. The movement of the blade relative to the handle was so small that they appeared to be rigidly connected. Research by the author (see section 5.4.2) had already established that the largest peak forces during prodding are almost completely axial so sensing other directions was not necessary. A readily available battery in the handle was able to power the buzzer continuously for several tens of hours.

An initial proof of concept model was enthusiastically received and several more prototype “buzzing prodders” were manufactured. The cost of large-scale production in Cambodia was estimated to be less than about USA\$20 per unit. Figure 5.26 shows the internal details (above) and a later type of outer assembly that uses the same mechanism (below).

5.8.1 Field testing a buzzing prodder in Afghanistan

A prototype buzzing prodder was field tested by deminers in Afghanistan. The trigger force was set to 40 N (4 kgf). All the deminers who tried the prodder, including senior training staff, were surprised at the ease with which they could exceed this force and repeatedly questioned the calibration of the prodder.

Initial attempts to excavate using the prodder always resulted in the buzzer sounding frequently, but after a few minutes some deminers were able to control the force they used quite accurately to avoid sounding the buzzer more than occasionally. A slow action easing the prodder into the ground was much more successful than the customary rapid stabbing and poking (see also section 5.4.2). This result strongly suggests that improved training with a force-feedback prodder could potentially reduce accidents due to accidentally detonating mines while prodding.

Future improvements to buzzing prodder

1. The sudden onset of buzzing as the preset force was exceeded did not give enough feedback to the user as they approached the “safe limit.” A two stage buzzer would be more useful, giving a quieter or lower-pitched tone first (at perhaps 40 N) and then a louder or higher pitched tone at a higher force level (perhaps 60 N). This would allow deminers to develop a habit of steady pushing, which was found to generate lower peak forces, by keeping the buzzer sounding in the lower zone.
2. A senior staff member of the demining training agency META in Afghanistan [Rah99b] suggested that a useful addition would be a warning when the angle of use of the prodder exceeded the accepted limit of 30 degrees from the horizontal. Again, a two-tone buzzer could be used to warn of perhaps an angle greater than 20 degrees and then a louder alarm at greater than 30 degrees.

Angle of entry of prodder

The angle of entry is increasingly critical as some demining organisations are changing their operating procedures to permit working while squatting instead of prone. While working prone the limited articulation of the shoulder makes prodding at steep angles relatively uncomfortable. Changing to a squatting or kneeling position makes entry very comfortable up to a near-vertical position. Unfortunately this may account for some of the accidental detonations of PMN mines in Afghanistan, and makes an angle-sensitive buzzing prodder for training a potentially useful tool.

5.9 Conclusions

Even though the advantages of “close-in” detection over remote detection are considerable, using sensing prodders to indicate that a target is “almost certainly” a mine is of very little value to deminers. The same procedure of excavating the target is followed whether the target is scrap metal or a mine/UXO so there is little or no saving in time and effort. Any increase in safety through being warned of a possible mine might be offset by an increase in complacency if no such signal was given.

The rotary prodders showed some promise, and had functioned well in the laboratory. However, field testing revealed two potentially important limitations to their application:

1. The noise, vibration and dust severely interfered with the delicate work of uncovering targets and this was completely unacceptable to deminers, even if the controlled force of a rotary prodder were to reduce the risk of an accidental detonation.
2. The whole design was based on the premise that deep penetration of hard soils would be advantageous. Demining advisors in the field considered gradual excavation a more useful technique than deep prodding and felt that the tool they needed was one capable of gently excavating hard, and nearly impenetrable, soils and road surfaces.

During the research it became clear that deminers, and even senior training staff, had no real idea of the force they were using and consistently underestimated how hard they were prodding. The best way, in the short term, to reduce accidents from prodding on to mines may be to improve deminer training.

The work on measuring prodding force and the force-detection system for the rotary prodders provided the basis for a training tool to demonstrate to deminers what a ‘safe’ prodding force feels like, in order to establish good working habits. This “buzzing prodder” could be further developed in the future to incorporate feedback about the angle of prodding as well as the force being used. Although the results of the work on rotary and sensing prodders were negative, the buzzing prodder fulfils many of the original requirements of the research in providing a better tool for deminers that is simple, cheap, robust and intuitive in its use.

Chapter 6

Neutron detection of explosives

6.1 Introduction

The work described in this chapter, like that in chapters, 4 and 5, was undertaken for two distinct reasons.

First, in its own right it was considered to have the potential to make a worthwhile contribution to the science of mine detection. Neutron methods show considerable promise (albeit less now than three years ago when work on this analysis was started), yet it appears that a rigorous examination of the fundamental limitations of the technique has not been published.

Secondly, this analysis of neutron techniques was a case study to illustrate a conclusion developed in chapter 3. In section 3.8 it was suggested that it is desirable to undertake a study to assess the possibility of a technique being researched of ultimately achieving *technical* success, according to humanitarian demining criteria, at a tolerable cost and in a reasonable time frame.

A technology for the direct detection of explosives, capable of the positive identification of mines/UXO before excavation, could permit a significant increase in humanitarian demining efficiency. The most promising methods for the bulk detection of explosives appear to be neutron and x-ray techniques and nuclear quadrupole resonance (NQR) [BG97, BG00]. At least initially, these are likely to be used as secondary discrimination in addition to metal detection as the primary location technology, i.e. as a method of determining whether a metal find is part of a mine/UXO or is scrap metal.

Any bulk explosive detector must be able to detect reliably the amount of explosive that a small AP mine contains when it is buried at the maximum required depth

of clearance. There is no need for particularly fast detection; reliable confirmation of mines/UXO requiring as much as five, or perhaps even ten, minutes would be sufficiently useful to warrant serious field trials.

Neutron methods have, until recently, appeared to be the most promising of the bulk explosive detection techniques, especially for relatively low-cost hand-held equipment if small radio-isotope neutron sources are used. However, in the last two years considerable progress has been made in developing NQR [BSG99, TCC⁺99] and may well eclipse neutron methods in the near future — NQR depends almost entirely on electronics which can be expected to improve rapidly and become cheaper, whereas neutron techniques depend more on fundamental radiation physics.

This chapter examines some of the different ways of harnessing neutrons for explosive detection and analyses why this apparently useful technology is not yet in use in the field for humanitarian demining, with particular reference to prompt gamma methods.

6.2 Neutron methods in current use

6.2.1 Explosive detection

The principal neutron reactions used for explosive detection are summarised in table 6.1.

The detection of explosives using neutrons is usually based on one or both of the following reactions:

1. The interaction of fast neutrons and hydrogen in the explosives (and in any plastics in the casing of a mine) to produce slow or thermal neutrons which are then detected. This is a neutron-neutron (n-n) method.
2. The excitation of elements in the explosive (and possibly in the casing of a mine) by neutrons to produce gamma rays of characteristic energies which can then be detected.

If the gamma rays are due directly to the interaction of fast neutrons with the elements this is fast neutron analysis (FNA). If the source of fast neutrons is pulsed it is also possible to measure:

- (a) Delayed subsequent reactions from neutrons that become thermalised.
- (b) Delayed subsequent reactions due to the particles and gamma rays produced by the prompt reactions exciting further reactions which also produce gamma rays; this is known as fast neutron activation analysis (FNAA).

		Neutron-gamma methods			n-n method
Neutron energy	14 MeV	1 to 8 MeV	Less than 1keV (thermal neutrons 0.025 eV)	> about 1 MeV	
Neutron source	D-T tubes (portable accelerator tubes)	D-D tubes (2.5 MeV) D-D accelerators (2.5 to 8 MeV) ²⁵² Cf sources ²⁴¹ Am/Be sources	Any neutron source with moderator to thermalise neutrons	Any neutron source	
Prompt reactions	FNA - fast neutron analysis. Elastic or inelastic scattering. Nuclear reaction with threshold < 13 MeV. Thermalisation then capture. FNAA - fast neutron activation analysis. High, medium and low energy activation.	FNA - fast neutron analysis. Elastic or inelastic scattering. Nuclear reaction with threshold < a few MeV. Thermalisation then capture. FNAA - fast neutron activation analysis. Medium and low energy activation.	TNA - thermal neutron analysis. Thermal neutron capture. TNAA - thermal neutron activation analysis. Low energy activation.	Neutron thermalisation Requires a few milliseconds for neutrons to be thermalised and “drift” to detector.	
Delayed reactions	H C N O Cl and most other elements	H N Cl and many other elements C barely detected (very slow) O not detected	H N Cl C not detected O not detected	H O barely detected Heavier elements not detected	

Table 6.1: Summary of neutron methods for explosive detection.

Based on Bach et al [BLTPB96, page 61].

Pulsed neutron analysis greatly enhances the ability to detect explosives but at the cost of greater complexity and the need for a switched neutron source. If thermal neutrons are used instead of fast neutrons to excite the target then the techniques are thermal neutron activation (TNA) and thermal neutron activation analysis (TNAA). The work in this chapter examines n- γ techniques in greater detail than n-n ones.

Airport cargo screening

Explosive and narcotics detection by neutron methods is well developed for airport security and non-invasive cargo screening [BG95, RD95, BCK⁺97]. These applications enjoy some advantages when compared to mine-detecting:

1. The equipment can be a fixed installation that is physically large, expensive and which requires a lot of power. Typically the cost is from USA\$350 000 to several million dollars and power consumption ten kilowatts or more. Accelerator based sources of neutrons are often used (see section B.2), but for baggage screening at airports radioisotope neutron sources are also used [GH95] [SAI99]; the fixed installations allow the use of large amounts of screening materials for safety with high-flux neutron sources.
2. The neutrons can be transmitted through the objects to be studied so that the source and detector can be widely separated. This considerably reduces background radiation problems at the detector.
3. The objects to be examined are generally surrounded by air which has a very low density, or other materials with low nitrogen and silicon contents. Mines are usually buried in soils which cause serious background problems, see section 6.7. Also, some of the ratios of abundance of elements crucial to explosives detection (H, C, O, N) show clearer differentiation between baggage and explosives than between soils and explosives [MK95].
4. The equipment can be remotely controlled to eliminate any radiation hazard to the operator.

Comparison of the ratios of the quantity of the four elements hydrogen, carbon, oxygen and nitrogen has been used for precise categorisation of explosives, plastics and narcotics in baggage, even in the presence of background signals [MK95]. Explosives are relatively rich in O and N but poor in C compared to many organic materials, however soil has a much higher oxygen content than explosives [BLTPB96, MFS95]. The ratio of gamma photons produced by the reaction $^{14}\text{N}(n, \gamma)^{15}\text{N}$ to the density of the material, measured with x-rays or otherwise, has also been used to distinguish

explosives from other nitrogenous materials [Bar94b]. The use of pulsed accelerator sources of neutrons allows tomographic analysis by measurement of time of flight [LCR⁺98, SGR91], but these tomographic and x-ray techniques are unlikely to be useful for demining.

6.2.2 Other relevant applications of neutrons

Soil moisture measurement

A well-established geophysical technique to determine accurately the water content of strata and soils is based on neutron thermalisation by water. A “moisture probe” is either lowered into a pre-drilled lined hole or is built into a penetrometer that is directly forced into the ground [Wor83, Zak94, US 95]. The probe usually contains a radioisotope neutron source (²⁵²Cf or ²⁴¹Am/Be) producing from about 1.5×10^5 to 10^7 neutrons per second, and a thermal neutron detector. Fast neutrons emitted by the source are thermalised by the water in the soil. The thermal neutrons are detected for a period of typically 15 to 60 seconds. The water content of the soil is closely proportional to the number of thermalised neutrons detected after compensation for the background radiation level. The range of penetration of neutrons in the soil is quoted as 100 to 150 mm in wet soils and 250 to 700 mm in dry soil, depending on the manufacturer.

n- γ bore-hole techniques

In addition to the n-n moisture probes, neutron-gamma techniques are also widely used in bore-holes. Applications include characterising the surrounding strata for petroleum and gas exploration, which can use either radioisotope or electronic neutron sources [CDG⁺96], determining the percentage ash content of coal seams [Tri95] and detecting small quantities of chlorinated hydrocarbons polluting ground-water [EG95, Nor95].

Detection of contaminants

Neutron detection of contaminants can identify minute concentrations of many elements, albeit very slowly. Typical applications include the analysis of pollutants in water. Using a seven hour exposure of a sample of nearly 1 m^3 of water and a neutron source of $5 \times 10^8 \text{ ns}^{-1}$ researchers identified 22 elements in the water of Manzala Lake in Egypt [AHASZH96].

6.3 Current research work on neutron detection of mines

The detection of anti-tank mines by neutrons has been successfully demonstrated by several research groups, for example Cousins [Cou97], SAIC Corp [Anc99, BRT96b] and Bach et al [Ran00]. The larger APMs can also be detected if they are near the surface.

6.3.1 A review of the literature

The number of projects and individual researchers who have published work on neutron detection of mines is limited, probably due to commercial and military constraints, and of the papers very few have given numerical results of mine detection trials. Leonhardt presented numerical results from testing a simple neutron thermalisation system in the laboratory [LKN96], Pekarsky gave useful details of his field trials of both thermalisation and neutron-gamma detectors [Pek98a, Pek98b], and the large Italian Explodet project involving collaboration between several major institutes and universities published a 42-page interim report in 1999 which included data from their modelling and early experimental work [VCCP+99]. Vourvopoulos and Womble gave some data from testing buried explosive simulants but the absence of information about the level of the background count precludes any meaningful interpretation of their results [VW00]. Their data also contained an anomaly; on burying the surrogate mines in their test area, an increase in gamma rays due to oxygen was noted. The relevant gamma ray count increased from 0.4 counts per second (cps) *less than* their standard (unreported) baseline to 1.0 cps above baseline for one mine, and 0.8 cps above baseline for another. However, soil has far more oxygen than explosives; Bach et al gave typical atomic densities of oxygen in soil as $6.9 \times 10^{28} \text{m}^{-3}$ and in explosive as $2.6 \times 10^{28} \text{m}^{-3}$ [BLTPB96].

Neutron thermalisation techniques for AT mine detection have been demonstrated successfully under field conditions, but are only applicable to dry soil conditions. Pekarsky has proposed using these n-n methods as a primary detection method and then using n- γ techniques to confirm the results [Pek98a]. In his report of trials of a hand-held low-cost n-n detector he stated that the detector count rate increased 43% from a background count of 1850 to a reading of 2640 above an AT mine containing 7.5 kg of explosive in a plastic case, buried at a depth of 60 mm. A similar mine with a metal case caused an increase of 33% to 2460, and for comparison a 500 ml bottle of water at 20 mm depth gave an increase of 48% to 2730. The effect of water can be clearly seen, as can the influence of a plastic mine case in thermalising neutrons, though Pekarsky makes no comment on the difference

between metal and plastic mine cases. With these large count rates the minimum increase over background count required for reliable detection is about 10% (see section 6.4). This system is unlikely to be able to detect a buried anti-personnel mine containing perhaps 75 g of explosive, just 1% of the charge of the AT mines. More recently SAIC have developed a thermal neutron backscattering system which was briefly mentioned by Rant [Ran00], and the European Union has funded further research on this technique in the Mineseye project [ESP00].

Neutron-gamma techniques, and especially pulsed $n\text{-}\gamma$ techniques which permit the analysis of both the interaction of fast neutrons during a short pulse from a neutron generator and the interaction of the subsequent thermal neutrons, have more general application than the moisture-limited $n\text{-}n$ techniques which are only suitable for deserts. Rant reports, without attributing, that pulsed techniques “improve the confidence limit of mine detection (95% confidence for 200 g TNT buried under 15 cm of soil) in comparison with TNA alone (only 30% confidence)” [Ran00].

This limit of detection accords well with other reports of trials. In a 1996 trial of a proof-of-concept TNA system made by SAIC, buried anti-tank mines were identified and the system was described [BRT96a] as able to “potentially determine if a target contains down to a half pound (227 g) of explosive.”

A version of the same TNA system, after a further two years of development, was used for the Canadian ILDP project and its performance in trials was reported by McFee et al [MCJ⁺98]. A radioisotope neutron source was surrounded by four large NaI scintillators; sophisticated electronics and algorithms were used to process the received signals and data. This is presumed to have included advanced methods for background cancellation to reduce the effects of silicon in the soil (see section 6.7.4). This system was able to confirm the presence of buried anti-tank mines at 200 mm depth in five minutes, and the presence of shallow, large anti-personnel mines with more than 100 g of explosive in the same time. Future developments will include the use of an electronic neutron generator instead of the radioisotope source. This is perhaps the most highly developed and field-tested system that has been reported and comes from a company, SAIC Corp, which has many years experience of supplying neutron-based airport luggage scanners and container tomographic analysis systems.

Porter noted that proof-of-concept has been clearly demonstrated, but that performance “fell short of the values needed to make the system operationally useful” [Por99].

6.3.2 Gaps in the literature

The publications most notable by their apparent absence are

- (i) a statistical analysis of the output signal of the detector required to give a known probability of detection p_D and false alarm rate FAR — the desired p_D is frequently taken as 99.6% for humanitarian demining but 80 or 90% for military breaching and
- (ii) a theoretical analysis of the limits of detection of the technique due to background effects of the soil.

Due to the lack of published analyses of the theoretical limits of the technique, it is not clear whether neutron detection will ever be useful for *humanitarian* demining. It seems likely that such analyses have been undertaken but not published for commercial or military reasons. This appears to be not uncommon; for example, Pekarsky does not mention filtering in his formal paper [Pek98a] yet in discussions with the author he was emphatic that he regards it as crucial to a successful design [Pek98b]. The explosive detection performance of current prototypes may well be very close to the theoretical limit imposed by moisture, nitrogen, and silicon in the soil, and available neutron fluxes. The need to optimise many parameters, and to extract the maximum performance from sources, detectors and signal processing has led to large, and very expensive, vehicle based equipment. Pekarsky's two hand-held detectors are notable exceptions. The current performance of n- γ systems is potentially useful for military purposes, and for some PC-BAC where roads need to be verified as being clear of AT mines, but does not yet closely approach the required detection rates for humanitarian demining.

The very recent paper by Porter (abstract available to the author at the time of writing) suggests that she may have addressed the need for an analysis of the limits of performance [Por99]. She called for the use of high-resolution HPGe detectors to eliminate the problems introduced by the 10.6 MeV prompt gamma ray from silicon influencing the detection of the desired 10.8 MeV gamma rays from nitrogen. Until recently HPGe detectors have required cryogenic cooling; experimental higher temperature versions are becoming available though they are expensive. This is interesting research but not likely to prove useful for humanitarian deminers in poor countries in the foreseeable future. The effect of soil silicon appears to have been ignored by many authors, including Pekarsky, so it must be concluded that his prototype equipment is measuring a soil background comprised of both the 10.8 MeV nitrogen and the 10.6 MeV silicon gamma rays. The limitation on performance of detecting only medium and large AT mines is therefore not surprising. Sparrow et al discussed the silicon background problem in a paper in 1998 [SPBMS98]; it is discussed further in section 6.7.

6.4 Detection criteria and statistics

Two fundamental factors affect the ability of a neutron detection system to distinguish reliably between the returned signal from the background, and the signal where a mine is present in addition to the background:

1. The mean number of counts per unit time from the background, and
2. The ratio of the count rates with, and without, the mine present.

Radiation is a random process; it is thus appropriate to use the Poisson distribution to define the probability function of a certain number of gamma rays being detected in unit time when the average number (mean) is known.

The Poisson function for the probability of x events occurring in a time interval, when the mean number of events in the same time interval is λ is given by:

$$f(x; \lambda) = \frac{\lambda^x e^{-\lambda}}{x!}$$

Thus the probability of k or fewer events occurring is

$$F(k; \lambda) = \sum_{x=0}^{x=k} \frac{\lambda^x e^{-\lambda}}{x!}$$

With a background count rate of λ_b , and a false alarm rate less than or equal to p_{false} a value for the maximum number of counts, k , in one time interval that can still be considered as background radiation, can be calculated, for the given probability that the signal is not a false alarm. In this case,

$$(1 - p_{false}) \leq F(k, \lambda_b)$$

This is illustrated in the left-hand part of figure 6.1.

Similarly, the *minimum* number k' , of counts per measurement time interval required to ensure that the signal from a mine (= background + mine), λ_m , will be identified as a mine with a probability p_D is given by

$$(1 - p_D) \geq F(k'; \lambda_m)$$

This is illustrated in the right-hand part of figure 6.1.

By setting these two count rates (k, k') equal, the required minimum ratio of the count rates of (background plus mine) to (background only) can be found. This ratio

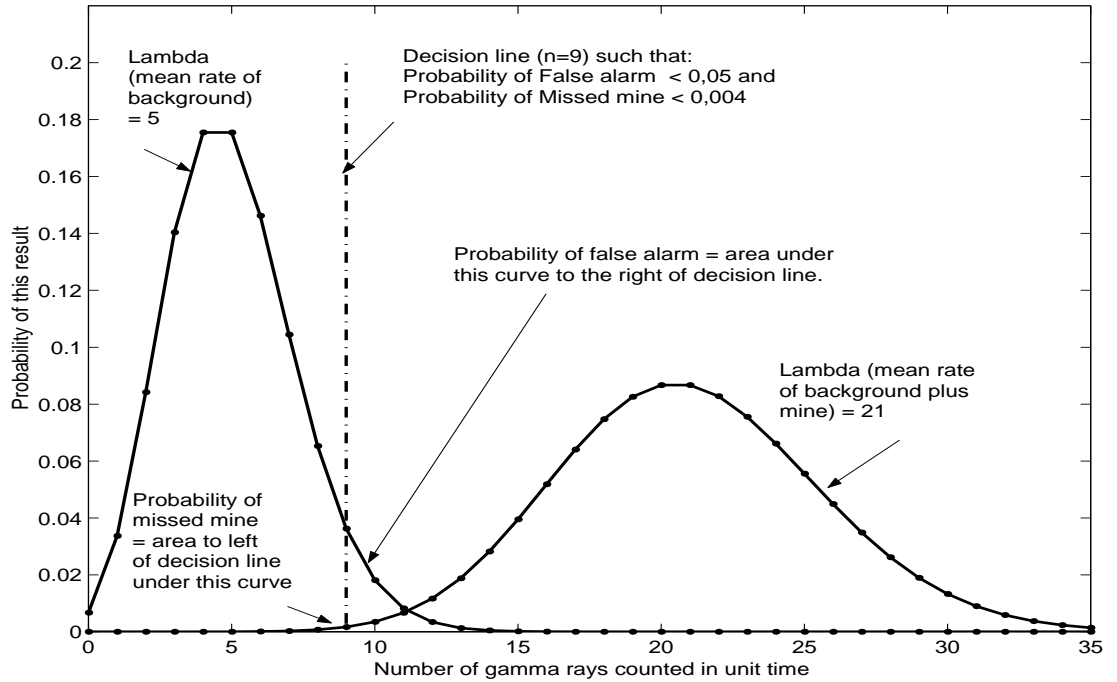

Figure 6.1: Calculation of the ratio of count rate with and without a mine present for given p_D and false alarm rate. Calculated for whole number values of count rate only.

is shown in figure 6.2 for three different pairs of conditions of false alarm rate and probability of detection. A false alarm rate of 10% may appear a strict criterion, but given the common ratio of 1000 items of scrap metal for each explosive item found this represents 100 false alarms for each mine/UXO if the neutron system is used in a confirmatory role. A false alarm ratio much higher than 100:1 may well create the perception in the field that the equipment does not offer sufficient advantage over existing techniques.

With a mean gamma count rate of ten per unit time the ratio of *mine plus background* to *background only* has to be between two and three to one depending on the false alarm rate and probability of detection required. If the background count rate is increased to 100 per unit time then the ratio required reduces to between about 1.3:1 and 1.5:1. Inspection of figure 6.2 shows that, for the same ratio of signals with and without the mine, changing from “loose” detection criteria of 95% p_D and 10% FAR to “tight” criteria of 99.6% p_D and 5% FAR requires approximately twice the mean background count rate. This can be achieved by doubling the time taken for detection. The ability to trade p_D , FAR and detection time is an attractive feature of neutron detection and makes possible realistic projections of the limits of performance of prototype equipment from measurements carried out by detecting

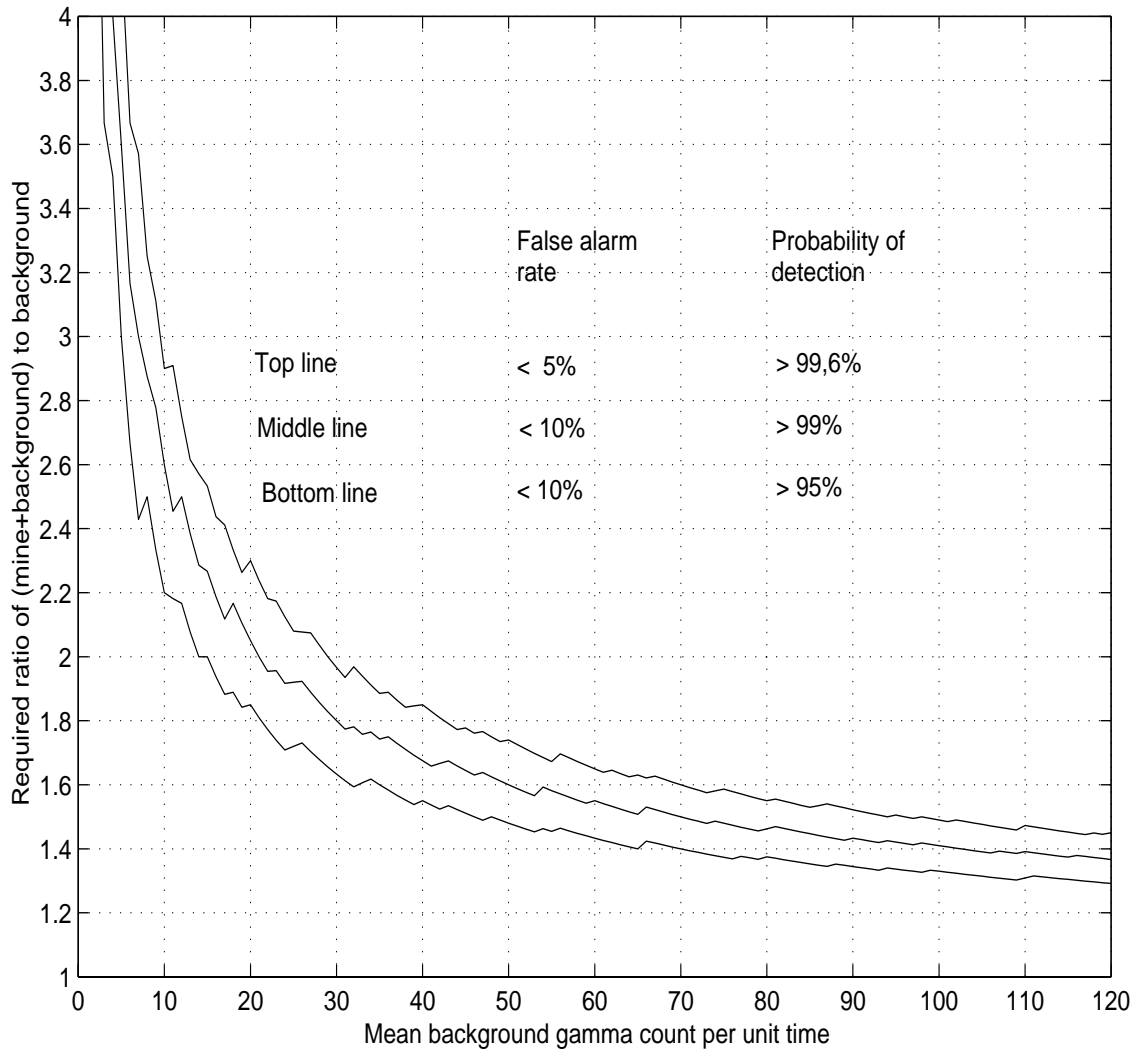

Figure 6.2: **Required ratios of gamma count rates with and without a mine present for given p_D and false alarm rate, vs background count rate.** Calculated for whole number values of count rate only — the discontinuities occur when both the value for false alarm rate and the probability of detection reach their set limits simultaneously and cause the ratio to increment twice between adjacent calculations.

surrogate mines during extended time intervals.

6.5 Neutron properties & generation, neutron & gamma-photon detection

6.5.1 Neutron properties and reactions

A description of neutron properties and details of the principal reactions of interest in detecting explosives are given in section B.1 in appendix B.

6.5.2 Neutron sources

Details of the production of neutrons by radioisotope and electronic neutron sources, and the detection of neutrons and gamma rays, are given in section B.2.

6.5.3 Advantages and disadvantages of electronic neutron sources.

Small portable particle accelerator tubes for neutron generation are produced commercially by several companies; typical examples are the APSTNG Neutron Generators [M F00] and the Soditron tube from the French company Sodern [Sod98]. The principal advantages of such a neutron generator are:

1. The output is a flux of mono-energetic 14 MeV neutrons which
 - (a) are more penetrating than low energy neutrons and
 - (b) have sufficient energy to permit the rapid detection of carbon and oxygen as well as hydrogen and nitrogen (see section 6.2.1).
2. The ability to produce short (microsecond), well defined pulses of neutrons. This permits a more sophisticated analysis of prompt and delayed gamma rays. More elements can be identified and some improved methods of compensating for background radiation are possible.
3. The ability to produce an intense flux of neutrons when in pulsed mode, up to three orders of magnitude greater than radioisotope sources.
4. A low (or zero) residual radiation hazard. This is clearly desirable in equipment that may be subjected to accidental detonation of explosives nearby, and simplifies safety shielding.

The principal disadvantages of these accelerator tubes are:

1. They are expensive and have a short operating life before the tube needs to be replaced. The Sodern tube system costs about £40 000 and the tube itself lasts 300 hours at maximum continuous output. The tube life is proportionally longer if lower average neutron fluxes are used (either by reducing the flux or using pulsed operation).
2. The power requirements of the drive electronics make them more suitable for vehicle-mounted systems than hand-portable ones. The only ways that such a system can be used in hand-held equipment are either to power it through

an “umbilical cord” or to use a backpack or “wheel-barrow” containing either batteries or a power source like a hydrogen fuel cell.

3. Their size and mass is fairly high (a few kilograms for the tube in a protective housing and perhaps 30 kg for the whole system including drive electronics).
4. There are restrictions on the sale of high-flux neutron generating technologies under the international nuclear non-proliferation treaty which would probably make their use in many mined countries unacceptable.

These disadvantages effectively rule out the use of electronic neutron generators for general purpose use in humanitarian demining. The cost, the complexity and the requirement for vehicle transportation of the heavy equipment to either the point of use or at least a point close to the target, appear to be incompatible with the design of tools and equipment for humanitarian demining, except for specific high-priority applications.

6.5.4 Disadvantages of radioisotope neutron sources.

The principal disadvantages of radioisotope sources, for use in humanitarian demining are:

1. The radiation hazard they pose in the field and during transportation and storage. If equipment containing a radioisotope source is destroyed by an accidentally detonated mine/UXO the spread of radiation can be prevented by protecting the source with a blast-proof container which is then recovered by a painstaking search. If recovery is not possible the half-life of ^{252}Cf of 2.6 years presents a rapidly diminishing hazard compared to that of ^{241}Am of 433 years.
2. The output is a broad spectrum and not a single well defined energy, as shown in figure 6.3. The energy of the neutrons generated is generally insufficient to allow rapid FNA and FNAA of elements (see table 6.1).
3. Most sources, including the popular $^{241}\text{Am}/\text{Be}$, have a significant gamma output as well as neutrons, which requires shielding both for radiation protection and also to prevent the gamma output causing background problems in the detector.

The first of these problems with radioisotope sources has been addressed by the production of switched radioisotope sources though they are not yet in common use; the second can be addressed with limited success by the use of filters (see section 6.5.6).

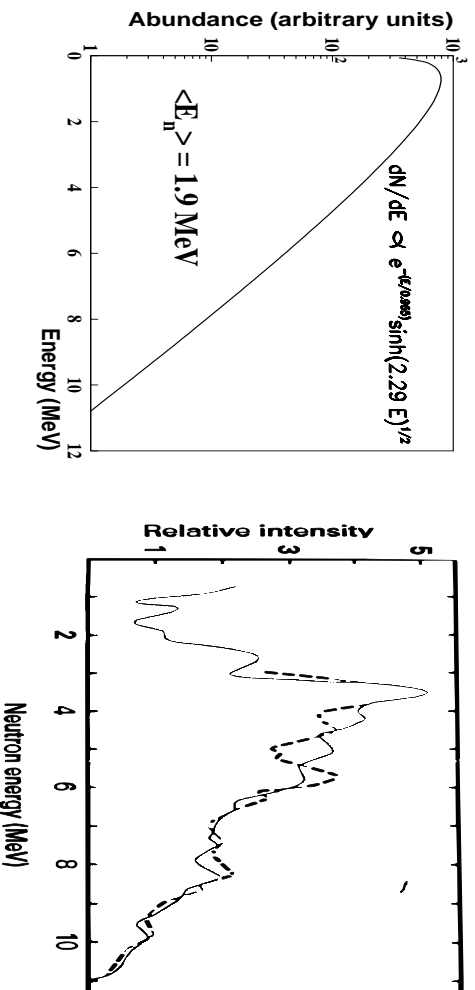

Figure 6.3: Spectra of neutrons from ^{252}Cf (left) and $^{241}\text{Am/Be}$ (right)

^{252}Cf from [VCCP+99, page 9], $^{241}\text{Am/Be}$ from [Dys93, page 176]

6.5.5 Switched radioisotope sources

Recently, switchable radiation neutron sources have been developed which appear to offer some significant advantages. The Argonne National Laboratory in the USA has patented a source based on disks with segments coated alternately with alpha particle emitters and light elements such as beryllium and boron [BDSR89]. With one or more fixed disks and one or more rotating disks in close proximity, the neutron flux can be switched on and off. By incorporating blank sectors on the disks, and spinning them rapidly, narrow pulses of neutrons can be generated, which opens the possibility of delayed neutron analysis as well as prompt analysis. Shielding requirements are also considerably reduced provided the neutron generator can be locked in the ‘off’ position when not in use. Several different alpha sources are suitable including ^{242}Cm , ^{241}Am , ^{238}Pu , ^{227}Ac , ^{228}Th and ^{210}Po ; in the overall calculation of radiation from a switched source in the off position, gamma radiation from the alpha particle source can be significant.

Another USA patent describes a system for a switched neutron source for a penetrometer probe [Nor95]. In this application a source of alpha particles (^{241}Am) is inserted into a tube of beryllium by energising an electromagnet. A spring automatically withdraws the alpha source when the electromagnet is not energised to stop the production of neutrons.

Although these switched sources protect the operator and public while the equipment is not in use they obviously do not offer any reduction to the operator’s radiation dose while the equipment is in use (see section 6.6).

6.5.6 Neutron filtering

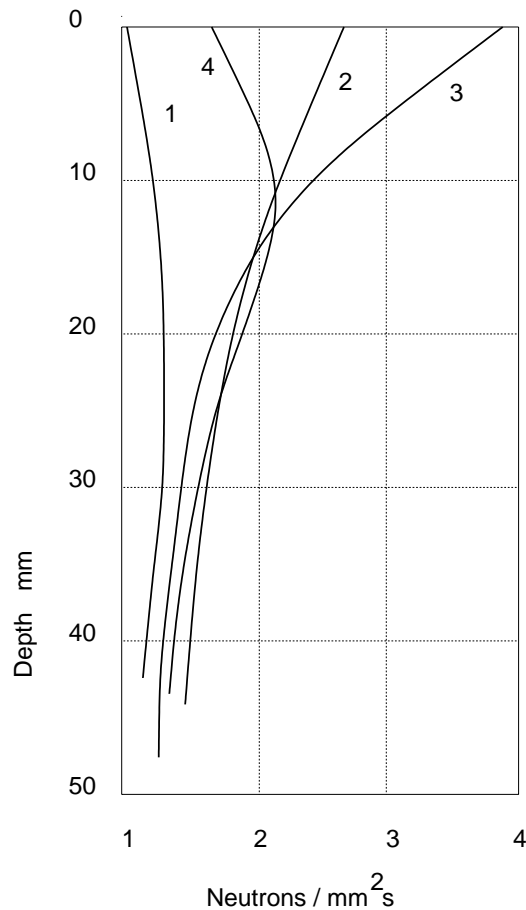

Figure 6.4: **Effect of different reflectors and filters on thermal neutron flux below surface of soil.** Curve (1) Be reflector, (2) C reflector, (3) Polyethylene reflector, (4) Polyethylene reflector and Cd filter. From [Pek82].

As Pekarsky noted in his earlier work on non-destructive testing (NDT) [Pek82], and emphasised in discussions with the author [Pek98b], reducing the background from the soil by filtering the neutron flux may be an essential part of using radioisotope neutron sources. A thin cadmium sheet (see figure C.2.1 in appendix C) or another suitable filter, will capture very nearly all the thermal and epithermal neutrons before they enter the soil (or the material under test in NDT). The peak thermal neutron flux can then be made to appear below the surface of the ground as the higher energy neutrons are readily thermalised by the hydrogen in the soil and moisture. This reduces the effect of the nitrogen in the soil closest to the neutron source (and to the detector in most configurations), as shown in section 6.7 for further details. By varying the filter material and thickness different energy ranges can be removed, see figure 6.4.

6.6 Radiation Protection and operator safety

6.6.1 Standard method of calculating radiation hazard

Neutrons are particularly hazardous because of their ability to penetrate soft and hard tissue to some depth before interacting with it to release alpha or beta particles, or gamma radiation, inside the organs of the body. The standard method of calculating the radiation hazard posed by a radioactive source is given in appendix D.

6.6.2 Neutron shielding

Neutron shielding is not entirely straightforward due to the number of different interactions possible with the shielding materials. Shielding may be necessary to reduce unwanted radiation reaching the detector even if operator radiation dose is primarily controlled by limiting exposure times. Safe containers are also required for transport and longer term storage of all radioisotope sources, even if they can be switched off.

Details of neutron shielding methods and materials are given in appendix C.2.

The attenuation of neutrons is usually assumed to be exponential, and the attenuation coefficient depends on the energy spectrum of the neutrons as well as the shielding materials.

6.6.3 Appropriate radiation safety levels for minefield equipment

Deciding on radiation safety levels appropriate for use in humanitarian demining is not entirely straightforward. Although demining is generally recognised as a hazardous occupation, in many countries it can be considered as very much safer per hour than driving a heavy vehicle. Deminer accident rates vary widely but are around one per 50 to 100 person-years and not all accidents result in death or serious injury. Some humanitarian demining organisations have more personnel killed and injured in road accidents than while demining. Clearly, safety standards appropriate for the rich countries, such as mandatory use of seat-belts and air-bags in vehicles, and low radiation exposures for the whole population, cannot be transferred directly to many poor and heavily mined countries. Conversely, deliberately exposing anyone to unnecessary risk from radiation hazards is irresponsible and unacceptable.

Deminers do not usually work a 40 hour week in the field, and during the working week will not be continuously using such equipment as neutron explosive detectors.

Precise exposure times will depend on individual circumstances and operating procedures. As humanitarian demining already has detailed SOPs to maintain safe working in hazardous areas it is well placed to control radiation exposure by introducing correct methods of working with radiation sources through the SOPs. The maximum annual dose for a deminer following good working practice should be within the guidelines, i.e. <20 mSv, though the hourly dose while operating the equipment may be based on a much shorter time than the 40 hour working week.

In some countries deminers spend more than half of their working time clearing vegetation. If the neutron detector is used to confirm small metal finds, but large metal objects are all exposed manually, it is very unlikely that the neutron detector will be in use for more than one-quarter of the six-hour working day. Teams of two or three deminers can share the work using a radiation source and can be rotated with other teams, so over the year exposure can be controlled. Radiation protection is thus as much a management problem as a design problem. In the case of an operator working for half of the year on this task (and the rest of the time on a task where radiation sources are not used), as one of a team of two, using the equipment for 25% of a six hour day for six days per week, 50 weeks per year, the hourly radiation dose to be within the annual guideline of 20 mSv per year is approximately 0.2 mSv per hour.

The two crucial points are:

1. The equipment must be effectively shielded when not in use, or switched off if a switched neutron source is used.
2. The equipment is not used continuously for long periods to search for mines but is used for relatively short periods to confirm whether a metal find is part of a minimum metal mine or is scrap metal.

When a switched source is used to confirm the presence of explosive, the radiation dose to the operator can be further controlled by implementing an operating procedure requiring:

1. The detector is placed carefully with the source turned off.
2. The operator steps back to increase the distance from the source — the dose decreases rapidly with distance due to the inverse square law for radiation flux.
3. The source is remotely switched on for a fixed period.
4. The operator approaches to remove the equipment and continue demining work.

The radiation dose can thus be controlled, and reduced to well below the accepted limits with only light shielding on the equipment. This approach is attractive in mined areas as individual deminers will have a minimum safe distance between them of 10 to 25 m when working, and all tools and equipment are collected at the end of each working day for secure overnight storage. Thus the risk to “members of the public” and especially to children is also well controlled.

The geographical survey method described in section 6.2.2 is widely used without any more precautions than training the operator in correct procedures and using a film badge to monitor exposure. Pekarsky, who has demonstrated hand-held explosive detectors [Pek98b] also uses lightly shielded sources. The neutron generator, a small radioisotope capsule, can be installed in his equipment in one minute using a two foot long (0.61 m) tool. For the installation procedure he calculated a whole body dose of 7 μSv , with 20 μSv to the extremities (hands and feet). In operation the deminer is about 1.5 m from the source (whole body) with extremities at about 1.0 m. For this distance the calculated dose was 230 μSv per hour whole body and 430 μSv per hour for the extremities. At these levels, and accepting a maximum operator dose of 20 mSv per year, the dose must be controlled by limiting exposure time and working methods, as described above. However, it seems unlikely that deminers would readily accept as long a handle as Pekarsky proposed for equipment to be used for searching for mines; precise location of the search head is essential if small targets are not to be overlooked.

Bach et al [BLTPB96] paid close attention to shielding an accelerator tube neutron generator and concluded that with 200–300 mm of mostly dense shielding for the 10^8 ns^{-1} source the radiation was about 25 $\mu\text{Sv/h}$ at 0.8 metres and 2.5 $\mu\text{Sv/hr}$ at 4 metres; the latter is an acceptable level of radiation for unrestricted access. The total mass of the shield was between 300 and 400 kg; clearly this is not suitable for a hand-held tool, but can be used for vehicle mounted systems. This level of protection may be necessary for research purposes in a European laboratory but hardly seems appropriate for a piece of equipment (a) to be used in a mined area where access is strictly controlled and personnel do not work close to one-another and (b) which has an accelerator tube neutron source that only poses a radiation hazard during operation. However, part of this shielding was also used for the collimation of the gamma radiation to enhance the detection performance of the equipment.

6.7 Specific problems of neutron methods in demining

Neutron detection of mines suffers from a number of important disadvantages compared to the scanning of luggage in airports (section 6.2.1).

- Neutrons cannot be passed through the mine and detected on the other side. The neutron source and gamma photon detector are therefore both on the same side of the target and their inevitable close proximity poses considerable difficulties in reducing the background count of direct gamma radiation.
- All military explosives are based on the four elements: hydrogen, carbon, nitrogen and oxygen. There are important background effects (i) from the soil moisture, generally between 5% and 40% of the soil mass and (ii) from the soil itself (which is about 50% oxygen, 30% silicon, and frequently contains about 0.2% nitrogen as well as hydrogen and carbon in organic matter).
- Neutron methods involve potentially fatal hazards to the operator and anyone else in close proximity to the source. Screening neutrons is far from easy (see appendix C.2) and is especially difficult when the equipment has to be highly portable.
- Neutrons interact with polycarbonate, the material from which safety visors for humanitarian deminers are made; this can reduce the mechanical strength of the polycarbonate significantly. Deminers working close to even a well-shielded neutron source could suffer a reduction in the protection offered by their visors. Accidentally storing visors close to a shielded neutron source for extended periods (for example while in transit) could also lead to a significant reduction in protection with little or no visible damage.

As with all demining technologies the criteria to be met are much more complex than just a proven ability to detect small amounts of buried explosive: the size, weight, cost, and speed of operation of the equipment are important, and the safety requirements of working in mined areas have to be taken into account. As yet, the various requirements have not been adequately satisfied. The rest of this section examines in more detail some specific problems of the neutron detection of mines for humanitarian demining.

6.7.1 Adequate neutron flux at mine

Irradiating a small buried mine with a sufficient neutron flux to permit its detection is difficult. The problem is not readily amenable to analytical solution due to the

thermalisation of fast neutrons between their source and the mine, and the interactions of the neutrons and the soil. These depend on the moisture content and the exact composition of the soil, and the spectrum (and collimation if any) of the neutrons emitted by the source. In practice Monte Carlo simulation methods are used to determine numerical results, for example [VCCP⁺99].

An idea of the magnitude of the neutron flux problem can be obtained using a considerably simplified model of a realistic scenario.

For the analysis, a cylindrical anti-personnel mine, 50 mm in diameter is assumed to be buried with its top surface at a depth of 150 mm. For neutron detection techniques to be useful to humanitarian deminers it must be possible to detect such a mine at about this depth. The neutron source is assumed to be 20 mm above the surface of the ground to allow for remnants of vegetation and surface unevenness. Radiation from the source is omni-directional, so the fraction of the radiation passing through the mine, *if the soil were transparent to neutrons* would be approximately $\frac{\pi \times (25 \times 10^{-3})^2}{4\pi \times (170 \times 10^{-3})^2} = \frac{1}{185} = 5.4 \times 10^{-3}$.

Similarly, if the mine is considered as a point source of gamma photons generated from the capture of neutrons (which is not altogether true), and the detector is a set of four 75 mm diameter scintillators at the same distance as the source (as used in [CIMC99]), a fraction of about $\frac{1}{20.4} = 49 \times 10^{-3}$ of the gamma photons will reach the detector.

The explosive charge of the mine is assumed to be 50 mm diameter and 20 mm thick, and hence 64 g mass, made from TNT (formula $C_7H_5N_3O_6$, density $1.64 \times 10^3 \text{ kgm}^{-3}$ [Oxl95]). This is typical of the explosive content of a medium size minimum-metal anti-personnel mine (see table 6.3).

The molecular weight of TNT is 227 so 64×10^{-3} kg contain $(\frac{64 \times 10^{-3}}{227}) \times 6.023 \times 10^{26}$ (Avogadro's constant) = 1.70×10^{23} molecules of TNT or 5.10×10^{23} atoms of nitrogen.

The capture cross section of the $N(n, \gamma)$ reaction is 0.075 barn (table B.1). The total capture cross section for thermal neutrons to produce gamma photons from nitrogen in the mine is therefore:

$5.10 \times 10^{23} \times 0.075 \times 10^{-28} = 3.825 \times 10^{-6} \text{ m}^2$, which is 0.195% of the total area of the mine.

The resulting proportion of gamma photons with energy of 10.8 MeV is quoted as slightly different figures by different sources; a typical value is 14% cited by Nebbia [Neb97]. Details of the relative yields of all the various gamma photon energies are given in [Tul99]. The detection efficiency of the scintillator may be taken as 70% (the exact value depends on the type and size of detector).

Thus, assuming (i) transparent soil and (ii) all neutrons arriving at the mine are thermalised, the fraction of neutrons resulting in a detected gamma photon at 10.8 MeV from the nitrogen in the mine is:

$$0.0054_{n-fraction} \times 0.049_{\gamma-fraction} \times 0.00195_{x-section} \times 0.14_{10.8MeV-fraction} \times 0.70_{scintillator} = 5.0 \times 10^{-8}$$

i.e. approximately 5 in 10^8 of the neutrons from the source will result in a detected gamma ray from nitrogen in the explosive. The assumptions make this an optimistic estimate.

The use of a suitable reflector above the neutron source can increase the number of neutrons reaching the surface of the soil by up to about 30% [VCCP+99]. This does not increase the useful flux at the buried mine by the same amount since the reflected neutrons will have a lower mean energy than neutrons directly incident from the source and hence will penetrate the soil less.

Radioisotope sources up to 2×10^8 neutrons per second are used for explosive detection. This is probably the largest feasible size as using a larger source causes two problems:

1. Increased shielding is necessary for radiation safety.
2. The gamma flux from the interaction of neutrons and the soil becomes so intense that “pulse pile-up” starts to occur in the relatively slow scintillators and electronics. Clifford et al [CIMC99] report work on fast detection circuits to reduce this problem.

Thus, even with highly optimistic assumptions and a very large (and expensive) array of scintillator detectors of high efficiency, the upper limit for nitrogen gamma rays of 10.8 MeV is of the order of less than five per second for a *medium size* AP mine at a depth of 150 mm. Small mines will be harder to detect due to their smaller cross section and the smaller amount of explosive (and hence nitrogen) which they contain.

6.7.2 Soil moisture

Moisture in soils thermalises and captures neutrons principally due to the hydrogen content. Even desert soils may contain enough moisture to strongly influence neutron techniques.

The moisture content of loamy sand and loam soils around landmines in Kuwait and Bosnia was measured by Hendrickx, Das and Borchers [HDB99] — the study was to determine the effect of soil moisture on mine detection using radar. Typical values

of 7 and 16 volume percent were measured for loamy sand and loam in Kuwait, and 14 and 30 v/v% for the same soil types in Bosnia.

Immediately after the few wet days during the year-long study in Kuwait, values up to 24 v/v% were recorded. The Kuwait dry season value agrees well with a soil at the “wilting point” of between 5% and 10% moisture by weight, where plants have extracted all the available moisture. Oven dried loose soil typically has a density of 1 000 to 1 800 kgm⁻³ depending on the degree of compaction and type of soil, so 10% moisture by weight is about 16% by volume. A typical density value for naturally “dry” soil on the ground (i.e. wilting point soil) would probably be in the range 1.3 to 2.0 × 10³ kgm⁻³

Even extended oven drying at temperatures of 110 °C will not remove all the bound water, especially in some lateritic soils. Clay minerals contain hydroxyl (–OH) groups that will thermalise neutrons even when the free moisture content is very low.

Typical maximum values (‘field capacity’) of water content of drained soil (by volume) are: sand 40–50%, medium textured soils 50%, clays 60%.

The mean free path of thermal neutrons diffusing can be calculated using the same methods as for the diffusion of gases [Kap63, page 581].

The average distance travelled by neutrons before absorption is the *absorption mean free path* $\lambda_a = \frac{1}{N\sigma_a}$ where σ_a is the absorption cross section per nucleus, and N is the number of absorption nuclei per unit volume.

The *transport mean free path* λ_{tr} takes into account the initial forward momentum of the neutron, the higher the energy of the neutron the greater its forward momentum and hence the further it will tend to penetrate. $\lambda_{tr} = \lambda_s(1 - \overline{\cos \theta}) = \frac{1}{N\sigma_s(1 - \overline{\cos \theta})}$ where λ_s is the scattering mean free path, the average distance that a neutron moves between scattering collisions. $\lambda_s = \frac{1}{N\sigma_s}$ where N is the number of scattering nuclei per unit volume and σ_s is the scattering cross section per nucleus.

As λ_a , λ_{tr} , and λ_s all include the number of scattering centres per unit volume in the denominator they can be directly scaled for the effect of a given percentage of water in soil, if the soil matrix has no impact on the thermalisation of neutrons. This is a reasonable assumption for damp and wet soils.

The values for water are $\lambda_{tr} = 4.3$ mm and $\lambda_a = 512$ mm [Kap63, page 584].

According to kinetic theory the diffusion coefficient, D , is given by $D = \frac{1}{3}\lambda_{tr}v$. From this, and Fick’s law, the special case of monoenergetic neutrons diffusing from an infinite plane source into a homogeneous material can be considered. A neutron source with a large moderator to completely thermalise its output above the surface of the soil (as proposed in [VCCP⁺99]) is a good approximation to this special case.

Soil moisture, percent	Half-length, mm for thermal neutrons	Percentage of neutrons reaching 100 mm depth
100	18.9	2.6
60	31.5	11.1
50	37.8	16.0
40	47.3	23.1
30	63.1	33.3
20	94.6	48.1
10	189.2	69.3
5	378.4	83.3

Table 6.2: **Attenuation of thermal neutrons by soil moisture, infinite plane model.**

For greater accuracy edge effects could be taken into account, but as the moisture content of soils can vary by more than one order of magnitude great precision is not required in this initial analysis.

Solving the equations by a standard method [Kap63, page 583] yields the result that the flux of thermal neutrons decays exponentially according to the relationship $n(x) = n_0 e^{-\frac{x}{L}}$ where x is the perpendicular distance from the plane source and L is the *thermal diffusion length* which is defined by the relationship $L = (\frac{\lambda_{tr}\lambda_a}{3})^{\frac{1}{2}}$.

The thermal diffusion length for water $L_{H_2O} = 27.3$ mm.

The value of L for soils with a percentage moisture content $\%_{H_2O}$ can be seen to be $0.0273 \times \frac{100}{\%_{H_2O}}$ m.

Thus, for example, 10% by volume moisture content in a soil gives $L = 273$ mm. This value is consistent with the range quoted for the moisture measurement technique in section 6.2.2.

From this the half-length for thermal neutrons in soils with various moisture contents can be calculated, i.e. the distance to reduce a planar neutron flux to half its value.

According to Kaplan [Kap63, page 295], the same exponential distance-based attenuation factor as is used for the case of an infinite plane source of thermal neutrons can be used for an omni-directional point source of neutrons, and is multiplied by the fall off in flux due to the greater effect of the inverse square law.

The Explodet project [VCCP⁺99] performed Monte Carlo calculations for neutrons arriving at a buried “window” of 100 mm diameter and 100 mm height, buried at a depth of 100 mm. Using a complex soil model they found that “dry soil” (0%

moisture) produced very few thermalised neutrons, but soil with a 10% or 20% water content produced significant numbers of thermal neutrons, and the least attenuation was for the highest energy neutrons in the simulation, 1 MeV [VCCP⁺99, page 9]. It appears that the absence of thermalised neutrons in “dry soil” was due to the error of considering that a dry soil would have a moisture content of zero, whereas a realistic dry soil may well have about the same moisture content as the 10% moisture model that was used. Indeed the soil composition used for the modelling did not include either hydrogen or carbon.

The same Monte Carlo simulation was then used to optimise a moderator to maximise the number of thermal neutrons arriving in the window for the zero moisture content “dry soil”. In practice this is a very poor strategy as the background interference from the soil will be maximised.

6.7.3 Soil nitrogen

Most researchers have focussed on detecting the 10.8 MeV gamma photons from nitrogen as a way of locating explosives. These are at the upper end of the thermal neutron gamma spectrum and, despite the contributions from nitrogen and silicon in soil, the background count around 11 MeV is relatively low [VCCP⁺99, page 37]. Only a small fraction of the neutrons captured by nitrogen produce gamma photons, about 96% produce protons. Furthermore, nitrogen has a large number of possible gamma energies, 50 are recorded [Tul99], and only about 14% of the gamma photons produced are at 10.8 MeV.

Soil nitrogen content is commonly about 0.2% by weight [Tow73, BW99], though widely variable. Soils very rich in organic matter may contain 2% or more; at the other extreme, infertile sands may contain less than 0.05 per cent. Normal figures for average and moderately fertile loams are from 0.10% to 0.30% [Tow73]. It can be assumed that nitrogenous fertilisers are not regularly applied to mined areas.

TNT, the commonest explosive in mines, comprises 18.5% by weight nitrogen, about two orders of magnitude greater than the soil.

A meaningful analytical determination of the effect due to the semi-infinite background of the nitrogen in the soil is not possible. There are so many variables to take into account that only a rough approximation can be made. The detected background depends, among other factors, on

- The precise composition and moisture content of the soil, and the variation of these with depth.
- The spectral content of the neutron source and any filter used to modify this

spectrum. Faster neutrons will penetrate further before interacting with the soil and buried explosives.

- The collimation (if any) of the neutron beam and the properties of any reflectors above or beside the neutron source. Collimation of thermal neutrons is not possible but limited collimation by absorbing materials (see appendix C.2) of higher energy neutrons is possible. Reflectors will increase the neutron flux but change its spectral content.
- The collimation (if any) of the gamma-photon detectors.
- The distance from the source to the detectors — as the soil nearest the neutron source is the most heavily irradiated by neutrons its contribution to the overall background is the most important. Increasing the distance between the source and detector tends to decrease the overall background count.
- In the case of a pulsed neutron source the length of the pulse and pulse repetition frequency are also relevant.

In order to obtain an understanding of the magnitude of the nitrogen background, the total nitrogen in the hemisphere centred on the neutron source (assumed to be a point source 20 mm above the soil surface) and of radius 190 mm can be considered; this is illustrated in figure 6.5. The 190 mm radius is used to just include a cylindrical mine 20 mm tall buried with its top surface 150 mm below the surface of the soil. The volume of soil in the hemisphere is 0.012 m^3 . The volume of the typical mine is $3.9 \times 10^{-5} \text{ m}^3$

If the abundance of nitrogen in the soil is assumed to be 100 times less than in the explosive the soil in the hemisphere has three times the total amount of nitrogen compared with the mine.

This estimate of the quantity of nitrogen in the soil shows clearly that (i) it is significantly greater than the amount nitrogen in a small buried mine, and (ii) it is irradiated by a neutron flux no less than (and near to the neutron source much greater than) the flux irradiating the mine. Hence the detection of mines involves measuring reliably a small percentage increase above the background level of the gamma radiation.

Collimation

Collimation might appear to be one method to reduce the effect of nitrogen in the soil; either by irradiating only a small solid angle of soil or by observing the gamma output from a small solid angle (see section 6.6.3). However, neither is practical for hand-held or even easily transportable equipment.

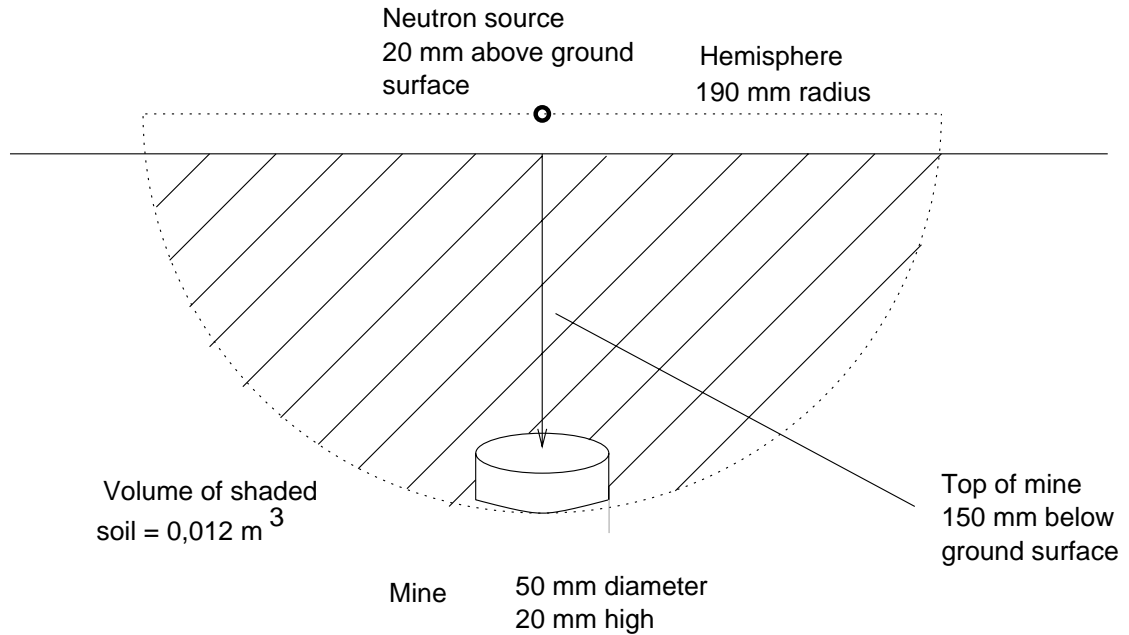

Figure 6.5: **Diagram to illustrate calculation of order of magnitude of nitrogen background.** The nitrogen in the soil nearest the neutron source receives a greater neutron flux density than the mine due to both the inverse square reduction in flux with distance from the source and to the thermalisation of neutrons and their subsequent capture which is dominated by soil moisture (see section 6.7.2 above).

Thermal neutrons diffuse in a gaseous manner and while they can be reflected they cannot be collimated. Explodet [VCCP⁺99] found that a lead reflector 50 mm thick increased the neutron count by 12%, 80 mm by 21% and 160 mm by 32%. Aluminium oxide Al_2O_3 was slightly less reflective. The longer path length of fast neutrons allows some collimation, but this requires large amounts of material to thermalise the neutrons, perhaps half a metre thickness of borated wax. Gamma shielding requires dense materials, usually lead. In all these cases the result is an explosive detector suitable only for permanent mounting on a vehicle. Even if it is not too heavy to lift, it will certainly be heavy enough to pose a serious safety problem when held above a suspected mine for several minutes.

6.7.4 Soil silicon

Many soils have a silicon content of about 30 w/w% which produces, among other energies, 10.6 MeV gamma photons on neutron irradiation. When using a scintillation detector such as $\text{NaI}(\text{Tl})$ (see section B.3), these 10.6 MeV gamma photons are indistinguishably close to the 10.8 MeV gamma photons produced by nitrogen.

The gamma-radiating capture cross section of silicon for neutrons of energy less than 1 keV is approximately double that of nitrogen, but the cross-section of Si above

1 keV can be two, or more, orders of magnitude greater than that of nitrogen as shown in figure 6.6. For nitrogen, the relative intensity of the 10.8 MeV to all gamma

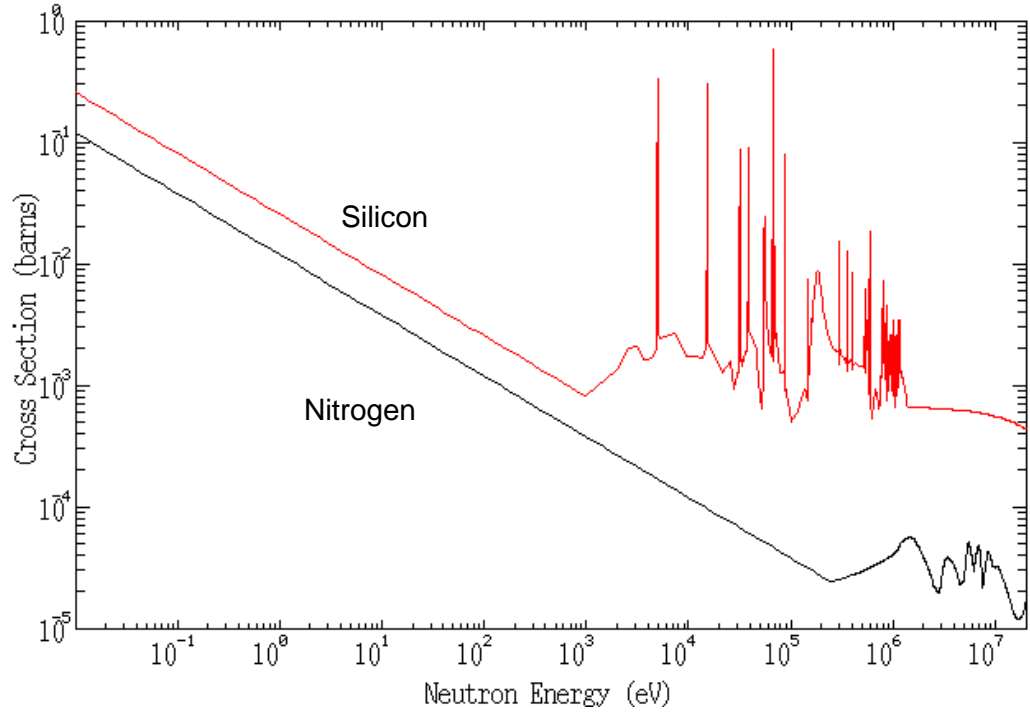

Figure 6.6: **Variation of radiative capture cross section of Si and N with neutron energy** From the on-line interactive spectrum facility at <http://hpngp01.kaeri.re.kr/CoN/endlplot.shtml> [Cha]

rays is about 14% [Neb97], while for silicon the 10.6 MeV gamma rays form 0.15% of the total [Tul99], about 100 times less. Thus, for neutrons with energy below 1 keV, the contribution from silicon (atomic mass 28) in a soil comprising 30 w/w% Si is about the same as if the soil had a nitrogen (atomic mass 14) content of roughly 0.3 w/w%, a realistic figure for agricultural soils. For neutrons with energies above 1 keV the relative contribution from Si is greater.

Subtraction of the background 10.6 MeV gamma rays due to silicon can be performed by measuring the background radiation due to the silicon content of the soil from the intensity of gamma rays of a different energy. However, this technique is not entirely straightforward:

1. Radiation is a random process and the mean count-rate (for either the silicon background or the nitrogen in the background and target) can only be defined probabilistically, see section 6.4 in this chapter. To be sure of detecting a mine with a probability of detection p_D , the signal from the mine must be such that it is clearly differentiated from the background when:

- (a) The gamma count from the *mine plus background* at 10.6 and 10.8 MeV is at its lowest statistically probable value consistent with the p_D and
 - (b) The gamma count from the energy chosen to measure the silicon background is simultaneously at the statistically highest value consistent with p_D and FAR. This leads to the calculated background cancellation for the silicon being more than the actual background and thus the compensated signal of *mine plus nitrogen background* is reduced, bringing it closer to the *background only* level and diminishing the observed effect of the nitrogen in the mine on the count-rate.
2. The detectors must be capable of measuring the large number of gamma rays from the silicon background
- (a) without the problem of “pulse pile-up” causing pulses to be missed and
 - (b) without losing the ability to discriminate the energy of pulses accurately due to secondary effects in the detector.

The cost and complexity of the electronics and computer processing necessary to undertake this background compensation make the technique unattractive for humanitarian demining.

6.7.5 Time to detect

The foregoing analyses can be combined to give a rough estimate of the time required to detect a mine.

If the medium size buried anti-personnel mine considered above is illuminated by a source of 10^8 neutrons per second it will produce perhaps one or two detected gamma photons each second in moderately moist soil — the thermalisation of neutrons by the plastic mine case may slightly increase this figure. The gamma background count from nitrogen in the soil is likely to be much more than three times that produced by the nitrogen in the mine, and to this must be added the background count from gamma radiation direct from the neutron source. The statistical analysis earlier in the chapter (section 6.4) shows that the number of counts per unit time for a statistically significant detection will be more than 120, giving a detection time of one or two minutes. This is an optimistic approximation for reasons already outlined; trials report detection of near-surface AP mines in five minutes.

6.8 Possible strategies for optimising neutron techniques

Maximising the thermal neutron flux at the mine

Mines are good neutron moderators. Not only is this the basis of the detection of explosives by the n-n method, which has been shown to be successful with large mines in very dry conditions, but the realities of humanitarian demining suggest that the practical need for explosive detection is only to distinguish between small metal scrap items and low-metal mines, all larger metal items can be easily found and removed (see chapter 2). Thus the technique is primarily aimed at plastic cased minimum-metal mines whose plastic cases are excellent neutron moderators. This appears to have attracted no attention from researchers and is discussed further in section 6.8.1.

There is thus an advantage in using neutrons with the highest possible energy and relying on the water in the soil, and especially the properties of the mine itself, to produce thermal neutrons for the n- γ reaction. The practicality of this was clearly shown by the measurement of neutron fluxes below the ground by the Explodet team. The thermal neutron count at 80 mm depth was measured from the 558keV gamma radiation produced by n- γ reactions of a buried sheet of cadmium. The soil moisture content was about 20% and the neutron source ^{252}Cf . The neutron count was greatest when there was no moderator between the neutron source and the top of the soil. This point appears to have gone unnoticed to this research group and considerable effort was expended on optimising the moderator for soils with zero moisture, which in practice do not exist.

The attenuation of neutrons by water decreases as the neutron energy increases. For 6 MeV neutrons the one-tenth length in water is 222 mm [CR80, page 295]. The scattering cross section of hydrogen decreases above about 100 keV so better penetration into moist soil by neutrons of higher energies can be expected. In soil which has a moisture content of 30% by volume the remaining thermal neutron flux was 33.3% of the initial value. With 6 MeV neutrons this rises to about 70%. Thus, heavy filtering of the neutrons from a radioisotope source to remove as much as possible of the spectrum below perhaps 1 or 2 MeV might improve the performance of the system, despite reducing the total output of neutrons significantly.

6.8.1 Plastic mine cases

Attention has apparently not been given to the very important contribution made by a plastic mine casing to thermalisation, possibly as a result of removing the

problem of explosive detection from the context of humanitarian mine clearance activity. The demining problem, as usually defined, is to detect all mines whether they have plastic or metal cases. In humanitarian demining, as has been repeatedly stated, it is easy to find metal cased mines with a metal detector; the real need is to discriminate between minimum metal mines and small pieces of scrap metal. A discrimination technique capable of identifying only plastic mines (and maybe wooden cased mines where they are used) is thus suitable (e.g. nuclear quadrupole resonance). Plastics all contain large amounts of hydrogen and carbon; polystyrene is $(C_8H_8)_n$, polycarbonate is $(C_{16}H_{14}O_3)_n$, and nylon 6-6 is $(C_{12}H_{22}N_2O_2)_n$ [Mar99]. Many small minimum-metal mines with 35 to 75 g of explosive have plastic cases with a mass of 100 g or more, see table 6.3.

The contribution to thermalisation by the mine case can be very much more important than that of the explosive. The detection of plastics to indicate mines can be reliably used in many mined areas as plastic scrap is not common, but it does mean that primary detection by a metal detector is necessary to find small metal-cased items such as detonators and very small UXO. The possibility of using the increase in carbon content due to the mine case has also, apparently, been overlooked. This offers a method of finding the mines like the Gorazde that have very small explosive contents; the 5 g charge of the Gorazde would be entirely undetectable by any bulk explosive detection method, but the 115 g plastic case might well be detectable from its hydrogen or carbon content.

Differential discrimination

The important effects of varying ground relief, the height of the detector above the ground, and variations in the background were commented on by Pekarsky [Pek98b] and BRTRC [BRT96a]. In comments about field-testing a vehicle mounted detection system BRTRC stated that “the background nitrogen level occasionally varied substantially over distances of a few meters. These variations were comparable to the largest signal seen from the anti-personnel mines . . .” Pekarsky suggested the idea of comparing a reading to a stored (and automatically updated) background level, but fails to take this one step further and suggest using differential measurements, possibly due to his use of neutron techniques as a primary mine locator. When used as a secondary (discrimination) technique a gain in sensitivity can be realised by changing from a fixed detection threshold to comparing the readings from a location where metal has been detected to a closely adjacent location without metal, which is thus assumed to have no mine/UXO present. It is possible to envisage a differential detector with a single neutron source and two detector systems separated by a short distance which offers compensation for background effects.

The Explodet project detection method uses sophisticated techniques in an attempt to overcome this limitation. On the assumption that “independent measurement of the background will not be easily possible” they analysed the histogram of counts of gamma energy for convex and concave segments using an algorithm that is “the numerical solution of a non-linear form of the heat equation” [VCCP⁺99, pages 37 and 38].

6.9 Conclusions

Detection of relatively deeply buried anti-personnel mines in a reasonable time, with the very low failure rate needed for humanitarian demining, by the method of detecting prompt gamma rays resulting from neutron irradiation is clearly extremely difficult. Proof of concept equipment for detecting anti-tank mines, which are significantly larger than anti-personnel mines, has been demonstrated by several research groups.

For humanitarian demining use the prompt gamma technique suffers from several important drawbacks:

- The four constituent elements of military explosives are all present in significant amounts in soil, so there are serious difficulties in distinguishing small mines from the background.
- Achieving an adequate neutron flux at a small buried mine to give sufficient output of gamma radiation for rapid detection is difficult when using portable neutron sources.
- The large silicon content of soil causes background radiation which is difficult to separate from the signal from nitrogen in the explosive.
- Accelerator based neutron sources offer the possibility of a more sophisticated and sensitive analysis from pulses of neutrons. However, these sources are prohibitively expensive, have a short life, and cannot be used in hand-held equipment due to their size, weight and power requirements.
- The use of neutrons is hazardous; donor agencies supporting humanitarian demining may not favour their use.
- The fundamental limitations of the technique appear to rule out the detection of small buried mines in a time short enough to be of use to humanitarian deminers.

Most of these problems are peculiar to demining; explosive detection for airports, cargo facilities and post offices, and the identification of car-bombs, are clearly viable applications of neutron technology.

Published research into the use of neutrons appears to have focussed heavily on the technology and not given enough attention to:

- (i) how the technique would fit in to the overall humanitarian demining operation, and
- (ii) the statistical analysis necessary to demonstrate that the required probability of detection and false alarm rates can be achieved theoretically for small mines buried in typical soils which contains all the elements present in the explosive. From this information the theoretical limits of the technique could be approximated.

No attention appears to have been given in published articles to the potentially useful properties for detection of the plastic cases of minimum metal mines.

Further problems of using neutrons with humanitarian demining include:

- The overall cost of the equipment would be considerably higher than a good metal detector.
- The operational value of the technique is open to question; deminers may prefer to continue with manual uncovering of targets instead of a sequence of setting the neutron detector in place, stepping back a safe distance and initiating a detection cycle, waiting for the result, moving the equipment out of the way and continuing demining. If detection is slow or the false alarm rate is high this may not save any time and the extra effort means that the equipment is unlikely to be used.
- While the use of radiation sources can be made safe by good operating procedures and suitable equipment design, they are subject to restrictions in transit and this makes delivery and international transportation of equipment considerably more difficult.

Neutron techniques appeared attractive when high-tech solutions to the problem of humanitarian demining were first sought in the early and mid 1990's but now appear largely unsuitable. One major factor in this change has been the significant improvement in conventional manual demining operations, and an associated improvement in metal detectors and personal protective equipment. More recently the large advances in NQR explosive detection, substantially due to the rapid advance of electronics and computing, have made NQR appear very much more promising than neutron methods. The safety concerns of using neutrons also make NQR a more attractive technology.

However there remain a few niche areas where neutron methods might appear to be the best choice. One is clearing railway lines; metal detectors cannot be used close to the rails and prodding is difficult in railway ballast. Radar systems generally do not work well due to the large number of voids in the ballast. A small, lightweight rail vehicle that automatically searches, albeit very slowly, a length of railway track using neutrons might well be a viable proposition. Another possible niche area is where there are zero-metal anti-tank mines, though in the future NQR or possibly radar, may be a cheaper and easier option in this case.

The detection of explosives using neutrons appears to be typical of many humanitarian demining technologies in two ways:

- (i) at first sight it seems to offer a solution but in the end is found to be possibly suitable for military demining, but not for humanitarian demining
- (ii) a great deal of money has been spent on developing the hardware without ever publishing a definitive analysis of the limits of the usefulness of the technology.

Country of origin	Mine type	Total mass of mine (g)	Explosive content (g)	Non-explosive mass, mostly plastic (g)
Argentina	FMK-1	253	152	101
Belgium	NR 409	183	80	103
Belgium	PRB M35	158	100	58
China	Type 72	140	51	89
Czech	PP Mi-Ba	340	152	188
France	MI AP DV 59 ¹	130	70	60
Germany	DM-11	231	122	109
Italy	AUPS	300	115	185
Italy	SB-33	140	35	105
Italy	TS-50	186	50	136
Italy	VS-50	185	43	142
Italy	VS2-MK2	135	33	102
N Korea	APP M-57	450	250	200
Pakistan	P4 Mk1	140	30	110
Romania	MAI-75	300	120	280
S Africa	R2M1	128	58	70
Spain	P-4-B	171	100	71
USA	M14	100	29	71
Vietnam	MN-79	100	29	71
Ex-Yugoslavia	Gorazde ²	120	5	115
Ex-Yugoslavia	PMA-2	135	100	35
Ex-Yugoslavia	PMA-3	180	35	145
Ex-Yugoslavia	TM-100 ³	100	100	0
Zimbabwe	ZAP No1, No2	200	140	60

Note 1 Completely non-metallic. Friction fuze.

Note 2 Low metal but not minimum metal. Included for the very small (undetectable) explosive content.

Note 3 Demolition block with threaded in detonator. Can have waxed paper case. Can be completely non-metallic if friction fuze used.

Table 6.3: **Mass of explosive and casing in minimum metal AP mines.**

All data from Jane's "Mines and Mine Clearance, Third Edition" [Kin98b]

Chapter 7

Conclusions and recommendations for further work

7.1 The context of humanitarian demining research

7.1.1 The nature of the problem

An initial review of humanitarian demining indicated that clearing the world of landmines in inhabited areas, although a daunting task, is perhaps more feasible than was once believed; there is some evidence that the number of abandoned landmines and UXO appears to have been exaggerated for several years by many sources. The figure of over 100 million mines world-wide which has been taken up and repeated widely is now considered a significant over-estimate.

The available data from Mozambique confirms that the direct impact of death due to mines over 13 years in that country was not only very much less than that due to diseases such as malaria and typhoid, but it was also an order of magnitude less than the death toll due to road traffic accidents. Data from several countries now shows that demining, when undertaken by trained personnel in a safe manner is not a particularly dangerous activity. Typical accident rates for deminers are now believed to be between one per 30 and one per 100 person-years. Accident reports suggest that deminers using good quality personal protective equipment who accidentally detonate small blast mines may have such minor injuries that they are sometimes able to return to work in less than a month.

7.1.2 The influence of military demining

Even though military minefield breaching and humanitarian land clearance are quite different in their aims, the origins of humanitarian demining lie in military demining and this heritage is still influential.

7.2 The existing literature

A review of the literature has shown that demining research appears to have concentrated heavily in just a few areas and that it lacks authoritative publications on some fundamental topics. In particular, there appears to be an important lack of published papers on:

- Analyses of the likely success of particular technologies in meeting *humanitarian* demining needs, undertaken early in the research and development cycle.
- The statistical basis for the analysis of the results of testing mine detection equipment. Research results are still sometimes published in terms that have no real statistical meaning. Allied to this is a similar lack of statistical rigour in quality assurance methods.

7.3 Research work in this thesis

7.3.1 Statistical analysis

A rigorous statistical analysis of a common method for the evaluation of demining equipment was presented, both as a contribution to research and to demonstrate that the absence of such work is not due to any excessive complexity or other difficulty.

The analysis clearly showed that reliance on crude detection rate data does not give meaningful results in feasible trials.

A method for improving the evaluation of mine detectors by using a parameter of “Margin of Detection” was proposed; this has application in quality assurance of demining as well as equipment trials.

7.3.2 Improved prodders

Proof-of-concept models of a range of sensing prodders were demonstrated as a potential route for improving manual demining, the most widely used method for

clearing land of mines and UXO. These prodders were shown to function at a technical level, but were not useful operationally for two main reasons.

- The tools were not able to penetrate hard ground which is where they might be expected to be most useful.
- On further analysis and after discussion with deminers, the tools did not appear to offer much improvement to the overall *process* of demining even when the equipment functioned technically. In the end the tools developed proved of little use as they essentially addressed the wrong problem. Improved *excavation* would probably offer more advantages than improved *prodding*.

The force used by deminers while excavating hard ground was measured and was found to be routinely more than sufficient to detonate many types of AP mine. This agrees well with deminer experience and anecdotal evidence. It was found that deminers consistently and significantly underestimated the force they use.

To address the problem of prodding in hard ground a method for reducing the force required to penetrate hard ground by using a prodder with a rotating tip was investigated. This was found to work well in laboratory tests but less well in tropical soils. The noise, vibration and dust produced made the tool very unattractive to deminers despite a potential reduction in risk due to lower force being used to penetrate the ground.

The increased cost and complexity of the rotary prodders was not outweighed by any significant advantage and they thus could not be considered as a useful tool.

To address the problem of deminers underestimating the force they use, a simple, low-cost training tool was designed. This gave an audible warning when an adjustable pre-set force was exceeded. A number of prototypes were produced using mechanical components manufactured in Cambodia.

7.3.3 Neutron detection of explosive (detection of prompt gamma rays generated by neutron irradiation)

A theoretical study of the use of the promising explosive detection technique of neutron irradiation and detection of the resulting prompt gamma radiation was made — both to evaluate this particular technique and also to assess the feasibility of appraising the potential of a new technique early in the research and development cycle.

Despite considerable research spending on neutron methods there appears to be no published fundamental analysis of the practical limits of the technique, nor of the

basic statistical work on the ratio of responses to the neutron stimulus when a mine is present or absent in the soil.

The study found that the technique in fact has fundamental limitations when applied to humanitarian demining. These include:

- The background effect of the soil which contains all four elements to be found in military explosives.
- The difficulty of safely generating an adequate flux of neutrons for the reliable detection of small buried mines, without using very expensive equipment. The use of accelerator-based neutron generators may possibly be able to overcome this disadvantage, but the cost and power requirements of these sources are such that they seem unsuitable for general use in humanitarian demining.

It was concluded that neutron methods do not have general application in humanitarian demining, though they may be attractive in some specialist areas.

For military demining and some early post-conflict demining by Peacekeeping Forces the limitations on cost and size can be less important. For military work the requirement to detect all small buried mines is not over-riding, and for both these applications vehicle-based systems of high capital cost may well be acceptable. Neutron detection thus has a possible role to play in military demining and peacekeeping operations.

7.4 Further work

Future work can be suggested in several areas:

- There appears to be a need for further critical evaluation both of proposed, and of currently researched, technologies for humanitarian demining. It may be the case that several techniques might be demonstrated by such analysis as having little or no application to non-military demining.
- The statistical work in this thesis, and the suggestion of the “Margin of Detection” parameter, require further development. The evaluation of demining equipment, of demining systems, and above all the development of quality assurance methods in demining are all areas needing further attention.
- The force-sensing prodder for training described in chapter 5 needs further refinement and testing. The addition of angle-sensing and two-stage warnings have been suggested in section 5.8.1; prototypes with these features should be

evaluated by demining organisations and production of this tool started if the results are positive.

- There is still a need for further work to provide deminers with improved tools and equipment. In particular there is a need for new tools which can be deployed in the field in a short timescale, even if they offer only a modest improvement to existing methods.

Appendix A

Discussion of the question “Should we try to identify mines?”

This appendix contains a submission to the Internet discussion list <network@MgM.org> outlining the argument that developing sensing prodders is probably of little real value and seeking comments from deminers and researchers. The idea of positively identifying scrap metal instead of attempting to identify mines is proposed as one solution; it is believed that this represents a new approach to demining research.

From: J R Gasser <esrpo@eng.warwick.ac.uk>

To: network@mgm.org

Subject: Should we try to identify mines?

Date: Thu, 22 Apr 1999 18:34:29 +0100 (BST)

SHOULD WE TRY TO IDENTIFY MINES?

The following may be regarded by in-the-field deminers as merely re-stating the obvious. However there are a number of research programmes working on acoustic and other techniques for identifying mines. Is this a waste of time in terms of practical humanitarian demining? Comments please.....

Assume that we are following the very common method of locating tripwires and vegetation clearance, followed by metal detecting and removing all metal objects by prodding/excavation.

In the future, as well as the metal detector, we will have an acoustic, or GPR or ultrasound or other detector that tells us when it finds the “signature” of a mine at the same place as the metal find. This might be by contact with the target object or it might be from the surface or remotely.

No matter how good this second detector is, it seems that:-

—Positive identification of suspect targets as mines adds little to the demining process. Being able to characterise mines does not help because it probably does not change the procedure in the field.—

Why?

If a target is positively identified as a mine then the procedure would be to uncover it carefully.

If it is a metal find that does not identify as a mine then it might be UXO or an improvised explosive device (IED) or simply an unusually oriented mine that has failed to identify.

So, if it is NOT a mine the procedure is probably still going to be to uncover it carefully.

In other words, positive identification of mines is not particularly useful unless we can guarantee to be able to identify every explosive target no matter whether it is a mine, UXO, improvised device or whatever - with a success rate proven in the field of 100%, or very near to 100%. If we could do this then the rest of the debris could be left in the ground (or dug up quickly) and a lot of time and effort saved. If we cannot do this, characterising only mines by GPR, acoustic or other means, is maybe a waste of time as the procedure of "uncover it" does not change.

What seems to be needed is not the ability to identify mines as such but to positively identify either (a) scrap metal which has no explosive device attached, and which can then be left alone (or dug up quickly so that the ground is left metal-free for QA purposes) or (b) all explosive devices without exception, no matter what type.

Many researchers, myself included, have worked on the need for improved discrimination/identification of mines, and proposed that as long as we can detect 100% of mines then a high false alarm rate is unimportant. The false alarm rate could be as high as 10 or even 100 false alarms for every mine as this is clearly better than the 1000:1 ratio of scrap metal to mines frequently encountered. However, I am now wondering if enough attention has been paid to the problem outlined above, that unless we can guarantee to identify all UXO and IED as well as mines then deminers still have to uncover every metal target so we gain nothing.

A more useful approach may be to look at identifying targets that are definitely safe. This gives an immediate gain in time and effort every time a piece of metal is either left in the ground (or dug out quickly), but automatically means that if there is any uncertainty at all the target is treated as a potential mine.

If we can positively identify even a small percentage of the debris then then speed

of ground clearance will be significantly improved in some cases. This is obviously not a trivial problem as the variety of debris is almost limitless. Is there perhaps a common type of debris in a region that we could easily identify as a starting point? Is it really impossible to distinguish a ring-pull, a long thin wire, or the very thin shell of a rusty tin can from the steel components of a mine?

As positive identification of mines only becomes really useful when we can detect every possible explosive device it may require detecting the explosive itself and not secondary characteristics such as metal content, dielectric discontinuity (GPR), acoustic properties, etc. No amount of advanced database technology can include every possible improvised device. If you are 100% confident that every mine/UXO/etc in your clearance area is readily distinguished from the surroundings then of course positive identification of mines and UXO is good enough, but that would seem to be the exception that proves the rule. For military purposes identifying mines is clearly very useful and may be completely satisfactory, but it does not in general guarantee clearance to the standards expected in humanitarian work.

There are only a few practical methods for detecting explosives in humanitarian demining: NQR (which has problems with some metal-cased UXO), certain neutron techniques, artificial noses and animal noses are the main four. Genetically engineered plants or organisms may be important in the future. None of these technologies is yet widely considered a mature and trusted method for finding individual mines, though dogs are routinely used in some areas for locating mined or mine-free areas and by some organisations for finding individual mines.

Comments??

Russell Gasser
Development Technology Unit (DTU)
Engineering Department
University of Warwick
Coventry CV4-7AL
England

Tel/Voicemail +44 (0) 1203 522339
FAX +44 (0) 1203 418922
E-MAIL esrpo@eng.warwick.ac.uk

Opinions expressed are personal and not the official position of the DTU or the University of Warwick.

Appendix B

Neutron properties & interactions

B.1 Neutron properties

Neutrons are uncharged atomic particles with a mass of approximately one atomic unit; they were discovered in 1932 by Chadwick. In free space neutrons decay with a half-life of 13 minutes.

Neutrons are characterised according to their energy; for explosive detection two energy bands are of interest.

1. **Thermal neutrons**, which are in thermal equilibrium with their surroundings. Their energy distribution is described by the Maxwell-Boltzmann equation: $v_0 = \sqrt{\frac{2kT}{m}}$, this is a skewed distribution. The most probable energy at 20 °C is 0.0252 electron-volts (eV), equivalent to a velocity of 2198 ms⁻¹.
2. **Fast neutrons**, which have an energy range from about 0.1 MeV up to about 20 MeV. The limits of the energy range are not precisely defined.

There is little interaction between neutrons and matter. Neutrons can collide with an atomic nucleus and scatter either elastically or inelastically, or can be captured by a nucleus. All the energy lost by the neutron during elastic scattering is transferred to the nucleus as kinetic energy.

Inelastic scattering is the process of creating an excited nucleus by transferring energy to it from the neutron. The neutron is slowed and the target nucleus commonly emits gamma radiation later when it returns to its ground state.

Neutrons can be captured by nuclei which thus increase their atomic mass by one and return to a stable state by emitting another particle or a photon. Most commonly this is a gamma photon whose frequency is characteristic of the element, though alpha particles, beta particles or protons are emitted by some nuclei.

Thermal neutrons mostly diffuse through materials until captured by an atomic nucleus and do not principally exchange energy through elastic scattering. The diffusion of neutrons, in a medium that does not strongly absorb them, is analogous to the diffusion of a dilute gas and is described by Fick's law of diffusion [Kap63, page 581].

The slower neutrons are moving (i.e. the lower their energy) the more likely they are, in general, to be captured by nuclei. However, some elements have strong resonances that capture neutrons of a specific energy (see section C.2.1). The likelihood of capture usually increases rapidly as the energy of the neutron reduces, in general it is proportional to $1/v$, where v is the velocity of the neutron. The probability of capture is conveniently expressed by assigning the nucleus a *capture cross-section*, an area usually measured in barns (b) (10^{-28} m²). Some typical values are shown in table B.1. Also shown are typical scattering cross-sections for thermal neutrons for bound atoms (atoms that form part of a molecule or larger entity in the solid phase). Silicon is included as it is a major constituent of the soil from which mines are to be distinguished. Figure B.1 shows the variation of the (n- γ) cross section of the four constituent elements of explosives with neutron energy.

During thermalisation fast neutrons lose energy by a series of elastic scattering events. This slowing down process is also called neutron moderation, and is readily achieved by light elements such as hydrogen, deuterium, carbon and nitrogen. The energy lost in a collision is maximal with hydrogen (the lightest element) and decreases as atomic weight increases. An analogy is that when a billiard ball hits another ball of the same mass it transfers half its energy; but when a billiard ball hits a large mass it bounces off with little energy loss. Carbon, atomic mass 12, is often used in the form of graphite as a neutron moderator even though on average it reduces the neutron energy only 15.8% as much per collision as hydrogen. The advantages of carbon are its low cost, its low capture cross-section of 0.0045 b [CR80, page 449] so it does not absorb many neutrons, and it is an easy material to handle.

Since neutrons lose on average half their energy colliding with a proton (hydrogen nucleus) the number of collisions required for hydrogen to moderate a neutron from 2.5 MeV to 0.025 eV, i.e. a factor of 10^{-8} , is $\ln(\frac{2.5 \times 10^6}{0.025}) = 18.4$. The number of collisions required for the same slowing by carbon rises to 114 [Kap63, page 572].

B.2 Neutron generation

Any neutron generator for use in mined areas must be portable. Research methods that use physically large particle accelerators to produce neutrons by bombarding a

Element	<i>Capture</i> cross section, σ_c , barns per atom for thermal neutrons	Approx <i>scattering</i> cross section, for bound atoms, σ_s , barns per atom for thermal neutrons
H	3.3×10^{-1}	57
D (deuterium)	5.2×10^{-4}	7.6
B	9.0×10^{-3}	5.9
C	3.4×10^{-3}	5.5
N (n,p) reaction	1.8	
N (n, γ) reaction	7.5×10^{-2}	
O	1.8×10^{-4}	4.2
Na	1.0×10^{-1}	
Si	1.7×10^{-1}	
Natural Cd	1.7×10^3	
^{113}Cd	2.1×10^4	

Table B.1: **Thermal neutron capture and scattering cross sections for some light elements and cadmium.** From [Kap63, VCCP⁺99, PNBW70, FKMM81]. Note: Nitrogen principally undergoes the reaction (n, p) — proton production — on neutron capture. Of the gamma photons produced by the (n, γ) reaction about 5% have energy = 10.8 MeV.

suitable target (typically deuterium, tritium or a light metal) are clearly not suitable for field use.

B.2.1 Portable accelerator tubes

Small portable particle accelerator tubes for neutron generation are produced commercially by several companies. The tritium-deuterium reaction used in the tube is [Kap63, page 561]:

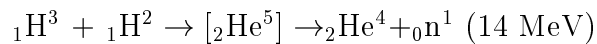

which can be written briefly as: T(d,n)⁴He. The D-T tube produces monoenergetic 14 MeV neutrons; a version that uses the deuterium-deuterium reaction is also available; it produces a flux of neutrons of 2.5 MeV by the reaction [Kap63, page 273]:

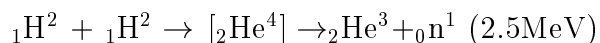

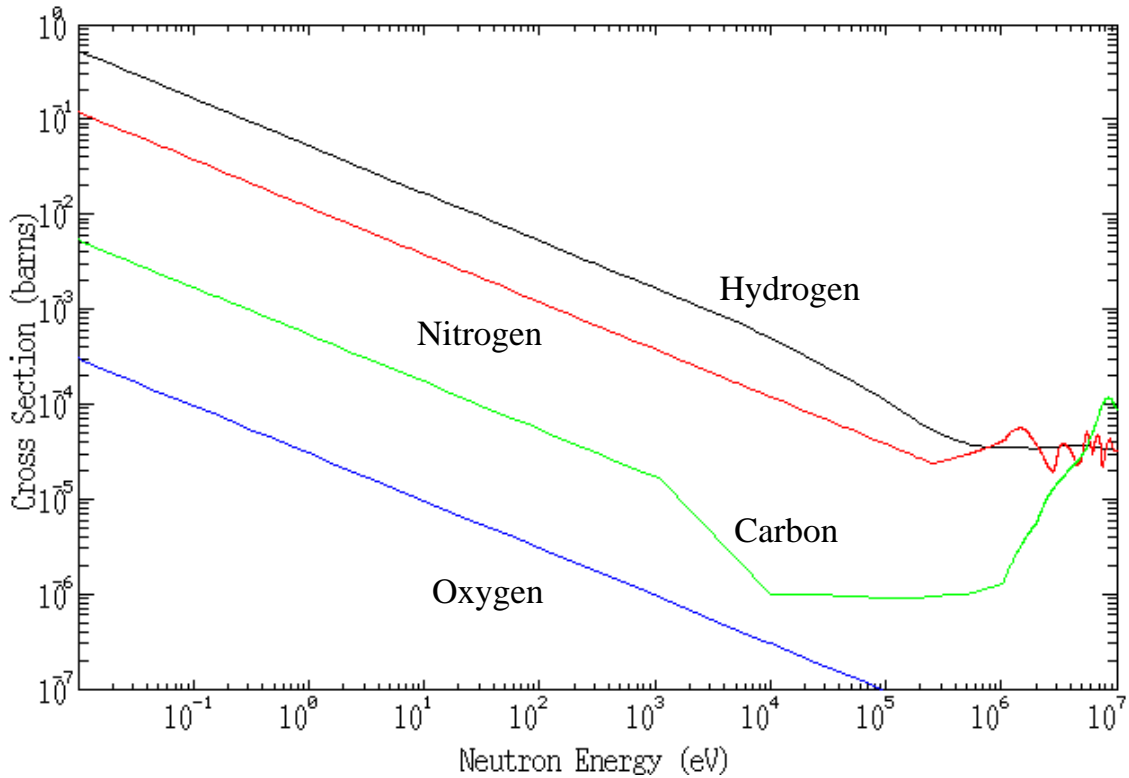
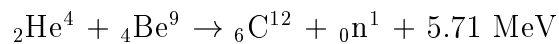

Figure B.1: **Neutron-gamma capture cross sections for constituent elements of explosives.** From the on-line interactive spectrum facility <http://hpngp01.kaeri.re.kr/CoN/endfplot.shtml> [Cha].

B.2.2 Radioisotope neutron sources

The second highly portable method of generating neutrons is to use a radioisotope source. Either a direct spontaneous fission neutron source can be used, most commonly ^{252}Cf , or an alpha emitter can be used to irradiate a light metal which then produces neutrons. Typically ^{241}Am is used with Be and the reactions are [Ary66]:



Typical fluxes generated are 10^6 ns^{-1} to 10^8 ns^{-1} . As with accelerator sources the neutrons are emitted with an equal intensity in all directions.

^{252}Cf has a half life of 2.64 years and decays mainly by two processes: alpha emission (96.9%) and spontaneous fission (3.1%). One gram emits 2.31×10^{12} neutrons per second [CR80, page 150]. The energy spectrum of neutrons is from a few keV to 14 MeV with an average energy of about 2.3 MeV and the most probable energy is about 0.7 MeV. $^{241}\text{Am}/\text{Be}$ produces electrons mostly in the higher MeV range with an average energy of 4.5 MeV. The spectra of these sources are shown in fig 6.3. ^{252}Cf is often preferred to $^{241}\text{Am}/\text{Be}$ because of its much lower output of gamma rays. This reduces the need for dense lead shielding to prevent direct gamma

photons causing a high background count in scintillator detectors.

B.3 Detection of neutrons and gamma radiation

B.3.1 Neutron detection

Since neutrons are uncharged they cannot be directly detected. Several neutron interactions form the basis of different detector systems, the one most commonly used is neutron absorption by a nucleus giving prompt emission of a charged particle.

The reactions $^{10}\text{B}(n,\alpha)^7\text{Li}$, and $^6\text{Li} + ^1_0\text{n} \rightarrow ^3_1\text{H} + ^4_2\text{He}$ are used in thermal neutron detectors. An ionisation chamber filled with BF_3 gas or lined with a compound of boron is used for the first of these. The cross section for these (n,α) reactions is proportional to $1/v$ so this method is only useful for detecting thermal and slow neutrons. Ionisation chambers are highly insensitive to gamma radiation from the neutron source if pulse height discrimination is used which reduces shielding requirements.

B.3.2 Gamma detection

Most neutron interactions of interest in explosive detection produce gamma photons of characteristic energies. There are several commonly used gamma detectors, choosing the right one involves considerations of cost, complexity, size, sensitivity and discrimination. Scintillation counters using thallium doped sodium iodide have been the most widely method due to high efficiency and (relative) robustness (see below). Hyper-pure germanium (HPGe) semiconductor detectors have been limited until recently by low efficiency and the need for cryogenic cooling; advances in materials processing are removing these constraints, albeit at a high cost. Semiconductor detectors offer very high resolution, the low resolution of NaI(Tl) detectors is one of their chief drawbacks.

Scintillation counters depend on materials displaying luminescence when exposed to radiation. To detect the photons produced, the scintillator is closely optically coupled to either a photomultiplier tube or sensitive photo-diodes. Crystals of sodium iodide doped need to be well sealed as NaI is highly deliquescent. The efficiency of detection of NaI scintillators is higher than many other detectors, especially for gamma radiation, and reaches a maximum for gamma rays with about 10 MeV energy [VCCP⁺99, page 17] which makes them well suited to the detection of the 10.8 MeV gamma rays from nitrogen. The overall efficiency of a scintillator is proportion of incident radiation detected and depends on the dimensions of the crystal

and the frequency of the radiation; values of about 50% can be expected for a cylindrical crystal 50 mm diameter and 50 mm deep irradiated with 1 MeV gamma radiation [Dys93]. The number of photons produced during the short pulse caused by incident gamma radiation depends on the energy of the gamma ray; this permits the discrimination of gamma rays with different energies. The energy resolution of NaI(Tl) is poor compared to other detectors; it is usually quoted as the width of the peak of ^{137}Cs γ -radiation of 662 keV, and a good NaI crystal will have a resolution of about 7%. NaI(Tl) crystals slowly become radioactive when bombarded with fast neutrons which limits their useful lifetime.

Other advanced materials used for gamma ray detection scintillators include gadolinium orthosilicate, cadmium-zinc-telluride (CdZnTe) and bismuth germanate. CdZnTe offers the advantages of high efficiency per unit volume, better energy resolution, and greater ruggedness than NaI(Tl). Unlike most germanium detectors it operates at room-temperature [CDG⁺96].

Appendix C

Radiation safety and neutron shielding

C.1 Radiation safety

The internationally agreed weighting factors (Relative Biological Effectiveness or RBE) for calculating the danger posed by neutrons were increased substantially in 1990 by the International Commission on Radiological Protection (ICRP) [Int91]. Currently they are as shown in table C.1 (gamma radiation has weighting factor 1).

Neutron energy	Weighting factor, RBE
<10 keV	5
10–100 keV	10
100 keV – 2 MeV	20
2–20 MeV	10
>20 MeV	5

Table C.1: **Relative Biological Effectiveness of neutrons according to their energy.** From ICRP Publication 60, 1990 [Int91]

The same publication recommends a maximum effective dose from artificial sources of 1 mSv per year for the public and 20 mSv per year for those who work with radiation. To put this in perspective, the typical annual dose received from all causes by a person in the UK is 2.5 mSv (equivalent to about 0.3 μ Sv per hour.) Over half of the total dose is due to radon in the home. Travelling on a jet airliner causes the dose due to cosmic rays to increase to about 5 μ Sv per hour and on Concorde, which flies at higher altitude, the dose is about 13 μ Sv per hour.

In calculating the risk to humans the following method is used [Nat89] and [MH79]:

1. The **absorbed dose**, the energy imparted by the radiation to unit mass of tissue, is calculated. The SI unit is the gray (Gy), equivalent to one joule per kilogram.
2. The **dose equivalent**, measured in sievert (Sv), is calculated from the absorbed dose multiplied by the RBE, and further multiplied by the N factor. The RBE compensates for the varying biological effects of different types of radiation (see above) and the N factor allows for future introduction of rate related or other factors. At present N is taken as equal to unity.
3. The **effective dose equivalent** is then calculated from a table of risk weighting factors for the different organs of the body affected by the radiation. Reproductive organs have the highest weighting (testes and ovaries have a factor of 0.25). The contributions from all affected organs are summed to give the total effective dose equivalent which is a rough indicator of the health risk of a particular exposure to radiation.

Occupational radiation risk is usually controlled by restricting access to hazardous areas. A typical system of classification is [MH79, page 96] :

1. **Uncontrolled access** to areas where exposure for 40 hours per week for 50 weeks per year results in a dose of less than 5 mSv per year, equivalent to $2.5 \mu\text{Sv}$ per hour.
2. **Supervised areas** where the dose does not exceed $7.5 \mu\text{Sv}$ per hour, so normal working is still within the guidelines of maximum permitted exposure.
3. **Controlled areas** where the radiation is up to $25 \mu\text{Sv}$ per hour. Workers should have their exposure monitored, and be subject to medical supervision.
4. **Restricted areas** where the dose rate exceeds $25 \mu\text{Sv}$ per hour, workers should have their access time-limited, use protective equipment and be subject to medical supervision.

C.2 Neutron shielding

Efficient shielding for neutrons is often formed from a suitable absorbing moderator such as hydrocarbon (paraffin) wax containing boron in the form of sodium borate (borax); this combination slows the fast neutrons to thermal velocities and captures them, see section C.2.1. The half-value thickness of borated wax for ^{252}Cf generated

neutrons is about 45 mm. Alternatively, a hydrocarbon moderator such as wax or high density polythene and then a layer of a material such as cadmium, which is highly effective in capturing thermal neutrons, can be used, see Table B.1 and Fig C.1. The gamma photons emitted by the capture reaction in the cadmium may require further screening, as do any gamma photons generated by the capture of neutrons in the dense material used to screen the direct gamma rays.

To reduce the radiation levels to a few micro-sievert per hour a radiation source of neutrons of about 1 GBq typically requires about 400 mm of borated wax and 30 mm of lead. This is usually arranged as a thick layer of lead to shield the direct gamma photons emitted by the radiation source, the wax, and then a thin (2–3 mm) outer layer of lead to reduce the prompt gamma photons of 2.2 MeV energy from the capture of thermal neutrons by the hydrogen in the wax.

Some special materials that offer both neutron thermalisation ability and high density for gamma protection have been developed. One is marketed under the trade name Krafton-XP3 [San98] and offers a one-tenth length (thickness for reduction of radiation to one tenth of its incident intensity) of 180 mm for a ^{252}Cf neutron source together with gamma shielding of a one-tenth length of about 138 mm for gamma radiation equivalent to a ^{60}Co source.

C.2.1 Shielding effect of resonant materials.

Due to resonance effects, cadmium has a remarkably high capture cross section for thermal neutrons, about 2 400 b [Cha]. Figure C.1 shows the variation of capture cross section with the energy of the neutrons.

The effectiveness of cadmium is largely due to the isotope ^{113}Cd , with a capture cross section for thermal neutrons of 21 000 b, and a peak cross section of 63 000 b for epithermal neutrons with an energy of 170 meV [Cha]. This isotope has a natural abundance of 12.2% and captures neutrons by the reaction $^{113}\text{Cd}(n,\gamma)^{114}\text{Cd}$. The gamma photons produced are low energy, 0.558 MeV [Tul99], and require separate shielding.

The number of neutrons passing through a thin sheet of a capturing material is given by the formula $n_t = n_0 e^{-N\sigma t}$, where t is the thickness of the sheet, N is the number of capturing atoms per unit volume and σ is the capture cross section [Bur73, page 91]. It follows that the one-tenth thickness of cadmium is about 0.3 mm. A 1 mm thick cadmium sheet will capture 99.96 % of incident thermal neutrons.

Boron also has a fairly large capture cross section of about 755 b, due the the 3838 b cross-section for ^{10}B . With a natural abundance of 19.8 % this is especially

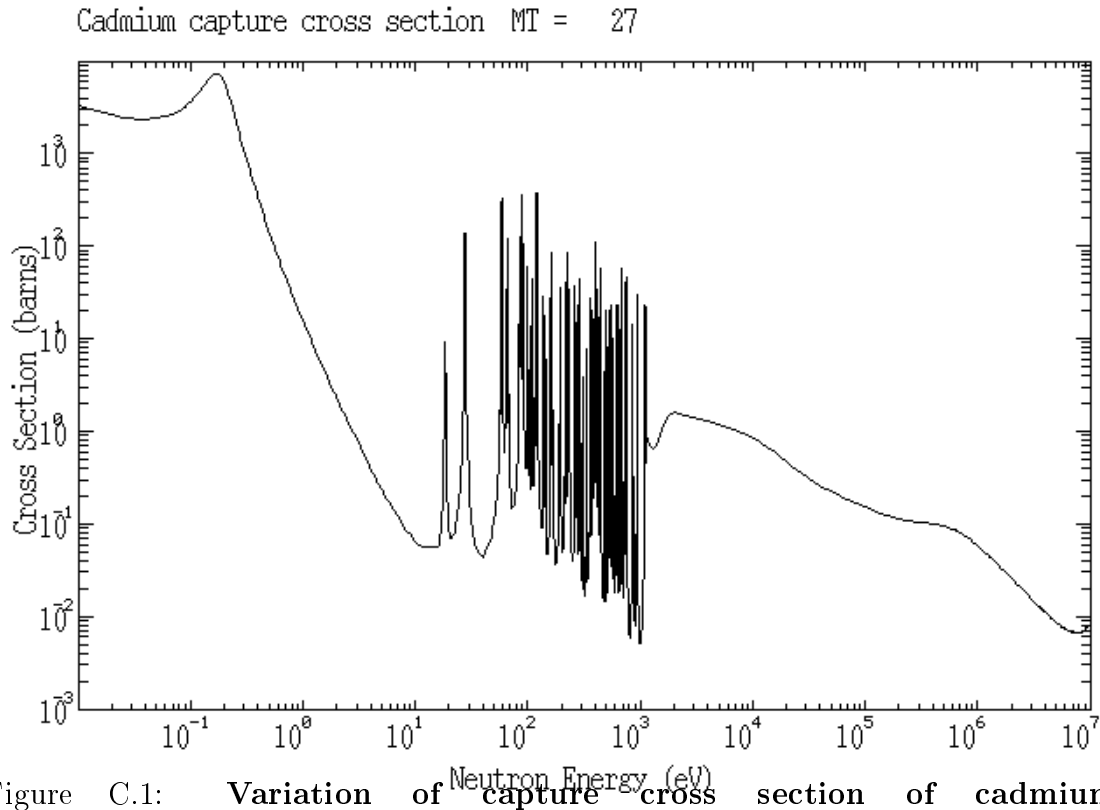

Figure C.1: **Variation of capture cross section of cadmium with neutron energy.** From the on-line interactive spectrum facility <http://hpngp01.kaeri.re.kr/CoN/endfplot.shtml> [Cha]

valuable as a shielding material as the reaction that captures neutrons produces alpha particles which are relatively easily screened. The reaction is $^{10}\text{B}(n, \alpha)^7\text{Li}$. However, in 93 % of events the ^7Li decays by emitting a 0.48 MeV gamma ray; this low energy gamma is relatively easy to shield [Tur95, page 222]. Boron is used in borated wax which thermalises and captures neutrons, it is also used in thermal neutron detectors (see section B.3). Borax (sodium borate) is a cheap and readily available material.

Appendix D

Computer Program for data logging

This program, written in Basic, was used to control the stepper motor and to capture data during the initial testing of rotary prodders in the laboratory. A description of this work can be found in section 5.5.2 of this thesis. The control signals and data were transferred through four parallel ports fitted to a 386 based computer.

The program listing has been omitted from the electronic version of the thesis, it is available from the author.

Glossary of demining terms

Based on the UN Glossary at the Internet Website <http://www.un.org/Depts/Landmine/Standard/glossary.htm> with minor additions from [Kin98b] and the author.

Anti-Personnel Mine (APM) - An explosive or material, normally encased, designed to wound, kill or otherwise incapacitate personnel. It may be detonated by the action of its victim, by the passage of time or by controlled means.

Anti-Tank Mine (ATM) - A mine which is designed to disable or destroy vehicles and tanks. The explosive can be activated by many types of fuze mechanism; normally by pressure, tilt rod, influence or command detonated.

Area Reduction - The act of defining and marking the extent of a mined area, usually undertaken as a part of a Level 2 survey. See survey.

Ballistic Protection - Protection from projectiles, often referred to for protection against sniper or small arms ammunition but in demining terms is used for protection against fragmentation and blast. See body armour.

Battle Area Clearance (BAC) - The term used for the clearance of all mines and UXO from an area of land.

Blow in situ - The destruction of any item of ordnance by explosives without moving the item from where it was found, normally by placing an explosive charge alongside. Sometimes referred to as Blow in Place (BIP).

Body Armour - In demining, the term body armour normally refers to a protective ballistic vest, but for EOD work it can refer to the full body "Bomb Suit".

Bomb Disposal - The act of disposing of UXO and IED. (NATO definition).

Bomblet - A term used to describe types of sub-munitions especially those packed within cluster bombs. Bomblets are designed to explode on contact with the target or ground.

Booby Trap - Any device or material which is designed, constructed or adapted to kill or injure and which functions unexpectedly when a person or object (vehicle) disturbs or approaches an apparently harmless object or performs an apparently safe act.

Bounding Mine - An Anti Personnel mine which is activated by either a trip wire or pressure. The activation of the fuze causes a primary charge to be initiated which ejects the mine to a predetermined height before the main fragmentation charge is initiated.

Box Mine - A mine normally manufactured from plastic or timber, containing the explosive charge and the activating mechanism. Mainly used for AP mines but has also been used for some AT mine models.

Breaching - Operations which clear a path through a mine field using a variety of military equipment, manual means, Mine Detecting Dogs or mechanical means.

Claymore Mine - A directional AP mine, the claymore consists of a curved outer case containing a huge number of fragments. Behind the fragments is a layer of explosive. The mine can be initiated by either pull or command detonation.

Clearance - Clearing an area of all mines, UXO and IED to a predefined standard.

Clearance Site - The site where demining activities (the removal of mines and/or UXO) are being conducted.

Clearance Standards - The standards that are to be applied to clearance operations. Normally specified in the contract document or clearance plan. In the UN it is normally achieved to a clearance standard of 100 per cent with a tolerance error of not more than 0.4 per cent.

Clear Lane - A lane that has been cleared of all mines and UXO.

Demining - Term used to describe all aspects of mine clearance. See mine clearance.

Destruction in situ - Destruction of the mine or UXO normally by explosives, without moving the item. See also Blow in Situ.

Disposal Work - EOD work.

Disarming - The act of making a mine safe by removing the fuze or igniter. The procedure normally removes one or more links from the firing chain. See also neutralisation.

Explosive - A substance or mixture of substances which, under external influences, is capable of rapidly releasing energy in the form of gases and heat. (NATO definition).

Explosive Detector Dogs (or Explosive Sensing Dogs) - Dogs that are specially trained to detect the vapours emitted by explosives contained in IEDs, mines and munitions. Some dogs can also be trained to detect tripwires and non-explosive booby traps. The dogs are normally referred to as explosive or mine detection dogs.

Explosive Ordnance - Munitions that contain explosives, nuclear fission or fusion material, biological and chemical agents. This includes bombs and warheads, guided and ballistic missiles, artillery, mortar, small arms ammunition, mines, torpedoes, depth charges, demolition stores, pyrotechnics, cluster munitions and dispensers, cartridges and propelled actuated devices, electric explosive devices and similar items that are explosive in nature.

Explosive Ordnance Disposal (EOD) - The detection, identification, field evaluation, render safe, recovery and disposal of Unex-

ploded Ordnance (UXO). EOD may be undertaken:

- a) As a routine part of mine clearance operations, upon the discovery of UXO.
- b) To dispose of UXO discovered outside mined areas, (this may be a single UXO, or a larger number inside a specific area).
- c) To dispose of explosive ordnance which has become hazardous by damage or destruction.

Fuse - A slow-burning pyrotechnic normally used to delay the initiation of a detonator.

Fuze - A designed and manufactured mechanism to activate a mine or munition. It can be designed for use by electrical, chemical or mechanical systems; by push, pull, pressure, release and time activation, singly or in combination. Usually consists of an igniter and detonator.

Hand Clearance - The act of clearing hazardous areas manually. Normally refers to clearance teams using mine detectors and prodders.

Humanitarian Mine Clearance - The removal of mines and UXO under the auspices of a humanitarian organisation in order to allow the land to be returned to the local community.

Improvised Explosive Device (IED) - An improvised explosive device is normally of local manufacture and is often associated with booby traps. It has all the elements of a mass manufactured mine or booby trap.

Influence Fuze Mine - A mine with a fuze which has been designed to be activated by the actual magnetic or other influences such infra-red radiation, radar, seismic or combinations thereof.

Mine - An explosive or other material, normally encased, designed to destroy or damage vehicles, boats, or aircraft, or designed to wound, kill, or otherwise incapacitate personnel. It may be detonated by the action of its target, the passage of time or by controlled means. (NATO definition)

Mine Action - All aspects at a national programme to address the mine problem in a country.

Mine Action Centre - Mine Action Centre usually refers to a facility, containing personnel who coordinate and assist the national mine action activities in a country.

Mined Area - An area declared dangerous due to the presence or suspected presence of mines. (NATO definition)

Mine Awareness - A method of informing, teaching and relaying messages about landmines to the public, normally through a mine awareness programme. Mine awareness encompasses mine risk education, mine awareness training (MAT) for peace-keepers, multi media presentations, and what action to take when a mine or UXO is found. It is intended to modify behaviour patterns to reduce casualties. A result of Mine Awareness is the flow of information back to a MAC about mine and ordnance locations.

Mine Clearance - The clearance of mines and UXO from a specified area to a predefined standard.

Mine Database - A collection of information on land mines and UXO, used for determining national plan priorities, collating and analysing the mine information, surveys, performance and other mine clearance related details. Most MACs also contain a limited map producing capability.

Mine Field - In land warfare, an area of ground containing mines laid with or without a pattern. (NATO definition)

Mine Protected Vehicles - Vehicles that have been specially designed or have additional protection from land mines in order to deflect the shock waves past the vehicle.

Minefield Survey - One of three disciplines in demining which involves the gathering of intelligence in order to identify suspect or known minefields areas. It also involves the reduction and marking of the areas prior to demining activities. There are three levels of

survey. See survey.

Minimum Metal Content - A term given to both AT and AP mines, but more commonly to AP mines with a limited amount of metal content. Minimum metal content mines normally have a few very small components of metal, for example a spring, ball bearing/s and the striker pin. In addition these metal components may have been manufactured from specialised material such as stainless steel which can be difficult to detect. It has been recommended that Protocol II of the Geneva Convention be amended to specify a metal content of at least 8 grams.

Monitoring - The authorised observation, by qualified personnel, in order to report on a clearance or demining activity, without taking responsibility for the quality or effectiveness.

Neutralisation - The act of replacing safety devices, such as pins or rods into an explosive item to prevent the fuze or igniter from functioning. It does not make the item completely safe as removal of the pins or rods will immediately make the item active again. It should not be confused with Disarming.

Non-Metallic Mine - A mine that contains no metal content but is a title often used, incorrectly for mines that have minimum metal content.

Nuisance Minefield - The term used for a few mines placed randomly around locations that will disorganise or demoralise an enemy.

Patterned Minefield - An Anti Tank, Anti Personnel or mixed minefield where the mines are laid out in known mine clusters, rows or mine strips. Can be laid by hand or mechanical means.

Perimeter Marking - The outer visible marking of a minefield, consisting normally of wire, tape and/or mine field warning signs.

Phony Minefield - An area of ground prepared using fences, mine boxes and other minefield identification material to give the impression of a live minefield without it con-

taining any landmines. Used to deceive.

Prodder - A tool, consisting of one or more pointed rods or tines that is used to probe the subsurface of the ground at a predetermined angle in order to locate buried ordnance. Also known as a probe.

Protective Minefield - A minefield laid by a unit in order to assist its local, close in protection. Normally consists of only Anti Personnel mines.

Quality Assurance - These process and procedures, management oriented, which if followed would result in a quality product or outcome.

Quality control - Activities focussed on determining through measurement, the level of compliance with technical standard.

Quality Management System (QMS) - The combination of an organisation's quality philosophy, quality assurance and quality control measures.

Render Safe Procedure (RSP) - Render Safe Procedures are the procedures that enable the neutralisation and/or disarming of mines and munitions to occur in a recognised and safe manner. (NATO definition)

Safe Lane - A lane that is clear of all mines and UXO

Site Mapping - A diagram which details the organisation of a working site.

Standing Operating Procedures (SOP) - A set of complete and detailed instructions for all aspects of the demining process. Strict adherence to SOPs is an important part of safe demining practice.

Sub-munitions - Sub-munitions are minelets or bomblets that form part of a cluster bomb or artillery shell payload.

Survey - The method of determining the location of suspect or verified mined areas and further determining through survey methods the perimeters of the actual mined area. This is undertaken by use of three levels of survey:
Level one : General Survey

Level two : Technical Survey

Level three : Completion Survey.

Tripwire - A wire attached to one or more mines in order to increase the activation area of the mine. Pressure on or the breaking of this trip wire will result in activation of the mine fuze. Normally attached to bounding and fragmentation type mines.

Unexploded Ordnance - Explosive ordnance which has been primed, fuzed, armed or otherwise prepared for use or used. It could have been fired, dropped, launched, projected yet remains unexploded either through malfunction or design or for any other cause.

Working Lane - The lane where one or more deminers are working.

Zero-metal mine - See Non-metallic mine.

Bibliography

- [AB 98] AB Precision Ltd. *Non-magnetic mine prodder*, page 584. In King [Kin98b], 1998.
- [ABHS99] Jason Arnot, Rhonda Bourdin, Andrew Hanson, and Paul Skoczylas. *A Mechanical Means of Land Mine Detection: Winning Land Mine Detection Project*. Internet Website <http://www.mece.ualberta.ca/landmine/winning.html>, Nov 1999. [Cited Mar 2000].
- [AHASZH96] A S Abdel-Haleem, M A Abdel-Samad, R A Zaghloul, and A M Hassan. ‘The Uses of Neutron Capture γ -Rays in Environmental Pollution Measurements’. *Radiat. Phys. Chem.*, 47(5):719–722, 1996.
- [AL96] C A Amazeen and M C Locke. *US Army’s New Handheld Standoff Mine Detection System (HSTAMIDS)*. In IEE [IEE96], pages 172–176.
- [Anc99] Ancore. *M-EDS mine explosive detector system*. Internet Website <http://www.ancore.com/mine.htm>, Dec 1999.
- [Ano00] Anonymous. *Croatia Sets Feb. 11 “ELF” Lab Tests to Validate Loch/ChemTech Landmine Detector*. Internet Website http://biz.yahoo.com/bw/000201/tx_loch_ha_1.html, Feb 2000. [Cited 12 Feb 2000].
- [Ant97] Davor Antonic. *Improving the Process of Manual Probing*. In Nicoud [Nic97], pages S4,30–S4,32.
- [AR96] D Antonic and I Ratkovic. *Ground probing sensor for automated mine detection*. Internet Website <http://www.rasip.fer.hr/~d/KoREMA.html>, Jun 1996. [Cited Mar 2000].
- [Ary66] Atam P Arya. *Fundamentals of Nuclear Physics*. Allyn and Bacon, Inc, Boston, 1966. Third printing 1970.
- [B+98] Dennis Barlow et al., editors. *Sustainable Humanitarian Demining: Trends, Techniques and Technologies*, James Madison University, 1998. Also published on Internet Website <http://www.hdic.jmu.edu>.
- [Bar94a] J Wesley Barnes. *Statistical Analysis for Engineers and Scientists*. McGraw Hill, 1994. ISBN 0 07 839608 5.

- [Bar94b] Colin Murray Bartle. *Procède et Appareil pour detecter des Substances cachées, notamment des explosifs*. France Patent 2,726,068, Oct 1994.
- [Bar97] A D Barber. Compressed air. In *Kempe's Engineers Year-Book 1997*, volume 102, chapter J6, pages 2115–2117. Miller Freeman plc, 1997. ISBN 086382 321 1.
- [BBSC99] Claudio Bruschini, Karin De Bruyn, Hichem Sahli, and Jan Cornelius. *Study on the State of the Art in the EU related to humanitarian demining technology, products and practice*. Internet Website <http://etro.vub.ac.be/~eudem/eudem>, Jul 1999. Final report of the study, eudemfinal.pdf can be downloaded from Website.
- [BCK⁺97] Douglas R Brown, Allison Coates, Stelly N Kuo, Robert Loveman, Ed Pentaleri, and Joel C Rynes. *Cargo inspection system based on pulsed fast neutron analysis*. In Lyle O Malotky and John J Penella, editors, *Physics-based technologies for the detection of contraband*, volume 2936, pages 76–84. SPIE, 1997.
- [BDSR89] Robert E Boyar, Alexander DeVolpi, George S Stanford, and Edgar A Rhodes. *Switchable Radioactive Neutron Source Device*. US Patent 4,829,191, May 1989.
- [BG95] D R Brown and T Gozani. ‘Cargo Inspection System Based on Pulsed Fast Neutron Analysis’. *NIM in Physics Research B*, 1995.
- [BG97] Claudio Bruschini and Bertrand Gros. *A Survey of Current Sensor Technology Research*. In Nicoud [Nic97], pages S6,18–S6,27.
- [BG00] Claudio Bruschini and Bertrand Gros. *WWW Links (Humanitarian Demining) - ExtendedRef*. Internet Website <http://diwww.epfl.ch/lami/detec/minelinks.html>, Feb 2000. Regularly updated.
- [BLTPB96] P Bach, P Le Tourneur, B Poumarède, and M Brette. *Neutron Activation and Analysis*. In IEE [IEE96], pages 58–61.
- [BN98] John W Brooks and Jean-Daniel Nicoud. *Applications of GPR Technology to Humanitarian Demining Operations in Cambodia: Some Lessons Learned*. Internet Website http://diwww.epfl.ch/lami/detec/detec.html#Detec_projects, 1998. [Cited Apr 2000] Located in index of papers as “Brooks98.” Can be downloaded as .pdf or PostScript file from web page.
- [Bot00] Ilaria Bottigliero. *120 Million Landmines Deployed Worldwide: Fact or Fiction?* Pen & Sword Books, an imprint of Leo Cooper, Jan 2000. ISBN 0 85052 317.
- [BRT96a] BRTRC. *Conclusions (Vehicle Mounted Detection System)*. Internet Website <http://www.demining.brtrc.com/solut/testplan/conclusi.htm>, Oct 1996. [Cited Mar 2000].

- [BRT96b] BRTRC. *Vehicle Mounted Detection System*. Internet Website <http://www.demining.brtrc.com/solut/testplan/vmds.htm>, Oct 1996. [Cited Mar 2000].
- [BRT99] BRTRC. *K9 program*. Internet Website <http://www.demining.brtrc.com/solut/testplan/k9progra.htm>, Apr 1999. [Cited Mar 2000].
- [BSG99] Andrew J Blauch, Jeffrey L Schiano, and Mark D Ginsberg. *Landmine detection using Feedback NQR*. In Dubey et al. [D⁺99], pages 464–473.
- [Bur73] W E Burcham. *Nuclear physics, an introduction*. Longman, second edition, 1973. ISBN 0 582 44110 2.
- [BW99] Nyle C Brady and Ray R Weil. *The Nature and Properties of Soils*. Prentice Hall, twelfth edition, 1999. ISBN 0 13 852444 0.
- [CDG⁺96] Christine Celata, Richard Donahue, Ehud Greenspan, Ka-Ngo Leung, Paul Luke, and Peter Zawislanski. *A Neutron Logging Instrument for Earth Sciences Applications*. Technical report, Lawrence Berkeley Laboratory, 1996. Internet Website <http://www.lbl.gov/Publications/LDRD/1996/Celata.html>.
- [Cha] J H Chang. *ENDFPLOT, Interactive neutron cross-section plotter*. Korea Atomic Energy Research Insititute Internet Website <http://hpngp01.kaeri.re.kr/CoN/endfplot.shtml>. [Cited Jan 2000].
- [Chi96] Richard J Chignell. *Ground penetrating radar — a sensor for mine detection*. In *The Detection of Abandoned Landmines: a humanitarian imperative seeking a technical solution* [IEE96], pages 103–108.
- [CIMC99] Edward Clifford, Harry Ing, John McFee, and Tom Cousins. *High rate counting electronics for a thermal neutron analysis mine detector*. In Doty [Dot99], pages 155–156.
- [CMA99] CMAC. *Private Communication*. Discussion of propsed method of mechanical mine clearance in Cambodia with Cambodian Mine Action Center Technical staff, Apr 1999.
- [Cou97] T Cousins. *Thermal Neutron Activation for Non-metallic Mine Detection*. Internet Website <http://www.dreo.dnd.ca/pages/factsheet/pdf/rt002e.pdf>, Jan 1997. [Cited Jan 2000].
- [CP34] C J Clopper and E S Pearson. ‘The use of confidence or fiducial limits illustrated in the case of the binomial’. *Biometrika*, (26):404–413, 1934.
- [CR80] Gregory R Chopin and Jan Rydberg. *Nuclear Chemistry Theory and Applications*. Pergamon Press, first edition, 1980. ISBN 0 08 023823 8.

- [Cra96] J A Craib. *A statement of user requirement - mine detection*. In IEE [IEE96], pages 16–20.
- [Cro98] Mike Croll. *The History of Landmines*. Pen & Sword Books, an imprint of Leo Cooper, Sep 1998. ISBN 0 850526 280.
- [D⁺99] A C Dubey et al., editors. *Detection and Remediation Technologies for Mines and Minelike Targets IV*, volume 3710. SPIE, Apr 1999.
- [DEW00] DEW. (DEW Engineering and Development Ltd) *SmartProbe(TM)*. Internet Website <http://www.smartprobe.com>, Jan 2000. [Cited Feb 2000].
- [DH95] B Dubuisson and G Harding, editors. *Law Enforcement Technologies: Identification Technologies and Traffic Safety*, volume 2511. SPIE, Jun 1995.
- [DHB98] A C Dubey, J F Harvey, and J T Broach, editors. *Detection and Remediation Technologies for Mines and Minelike Targets III*, volume 3392. SPIE, Sep 1998.
- [DHW97] Kenneth Dawson-Howe and Tomos Williams. *Automating the Probing Process*. In Nicoud [Nic97], pages S4,24–S4,29.
- [Dot99] F P Doty, editor. *Penetrating Radiation Systems and Applications*, volume 3769. SPIE, Oct 1999.
- [DY99] Pascal Druyts and Yann Yvinec. ‘*Website with information about humanitarian demining*’. Internet Website <http://www.sic.rma.ac.be/Research/HumDem/>, Nov 1999. [Cited Mar 2000].
- [Dys93] N A Dyson. *Radiation Physics with Applications in Medicine and Biology*. Ellis Horwood, second edition, 1993. ISBN 0 13 751108 6.
- [EG95] Anthony L. Endres and John P. Greenhouse. *Thermal Neutron Logging for Chlorinated Solvent Contamination in Aquifers*. Internet Website <http://www.mgls.org/95Sym/Papers/Endres/index.html>, 1995. [Cited Jan 2000].
- [ESP00] ESPRIT. (EU ESPRIT programme), *Mineseye*. Internet Website <http://www.cordis.lu/esprit/src/29958.htm>, Mar 2000.
- [FKMM81] Gerhart Friedlander, Joseph W Kennedy, Edward S Macias, and Julian Malcolm Miller. *Nuclear and Radiochemistry*. John Wiley and Sons, second edition, 1981. ISBN 0 471 28021 6.
- [GH95] Prasad Gokhale and Esam M A Hussein. *Analysis of transmitted spectrum for identification of materials using isotopic sources*. In Dubuisson and Harding [DH95], pages 25–32.
- [GIC00] GICHD. (Geneva International Centre for Humanitarian Demining) ‘*Website with information about humanitarian demining*’. Internet Website <http://www.gichd.ch>, Feb 2000. [Cited Mar 2000].

- [Goo99a] D E M Gooding. *Humanitarian Demining Technology Development Programme*. Internet Website http://www.eng.warwick.ac.uk/DTU/mines/mini_mam.html, Nov 1999. [Cited Mar 2000].
- [Goo99b] D E M Gooding. *Humanitarian Demining Technology Development Programme: Protective equipment and handtools*. Internet Website http://www.eng.warwick.ac.uk/DTU/mines/protective_equipment.html, Nov 1999. [Cited Mar 2000].
- [GPT97] R Gasser, M Prince, and T H Thomas. *Development of Tools for the Sustainable Demining of Farmland*. In Nicoud [Nic97], pages S6,11–S6,17.
- [GT98a] R Gasser and T Thomas. *A device for use in mine and ordnance clearance*. UK Patent Application 9822029.6, Oct 1998.
- [GT98b] R Gasser and T H Thomas. *Prodding to Detect Mines: a technique with a future*. In IEE [IEE98], pages 168–172.
- [GT99a] Russell Gasser and Terry Thomas. ‘Humanitarian Demining Research; has it wasted time and money?’. *Hidden Explosive Detection Workshop, Rovereto, Italy*, Jun 1999.
- [GT99b] Russell Gasser and Terry Thomas. ‘The human touch: Military-driven technology is useless for clearing mines in villages and rice fields.’. *New Scientist*, 164(2212):52–53, 13 Nov 1999.
- [GT00a] R Gasser and T H Thomas. *Working Paper No. 54: The Problem of Evaluating the Performance of Landmine Detection Systems*. Technical report, Development Technology Unit, School of Engineering, Warwick University, 2000.
- [GT00b] Russell Gasser and Terry Thomas. ‘Developing New Technology for Humanitarian Demining’ . *Journal of Mine Action*, 4(1), Mar 2000. Also published on internet Website <http://www.hdic.jmu.edu/hdic/journal/4.1>.
- [GT00c] Russell Gasser and Terry Thomas. ‘The Human Touch’ . *Journal of Mine Action*, 4(2):46–47, Jun 2000. Also published on internet Website <http://www.hdic.jmu.edu/hdic/journal/4.2>.
- [HDB99] Jan M H Hendrickx, Bhabani S Das, and Brian Borchers. *Modeling distributions of water and dielectric constants around landmines in homogeneous soils*. In Dubey et al. [D⁺99], pages 728–738.
- [Hon00] Honeywell Inc. *Honeywell SSEC - Magnetic Sensors Index*. Internet Website http://www.ssechoneywell.com/products/magsensor_index.html, Mar 2000.

- [HW99] Paul Horowitz and Jonathan Wolff. *The Acoustic Mine Detector Home Page*. Internet Website <http://mc.harvard.edu/mines/index.html>, Mar 1999. [Cited Mar 2000].
- [ICR96] ICRC. *Anti-personnel Landmines. Friend or foe?* ICRC (International Committee of the Red Cross), Geneva, Mar 1996. ISBN 2 88145 076.
- [IEE96] IEE, editor. *The Detection of Abandoned Landmines*, volume 431 of *Conference Publications*, Oct 1996.
- [IEE98] IEE, editor. *The second international conference on the Detection of Abandoned Landmines*, volume 458 of *Conference Publications*. IEE, Oct 1998.
- [Inc00] Nomadics Inc. *Fido Landmine Detector*. Internet Website http://www.nomadics.com/Landmine_Detector/Fido/fido.htm, Jul 2000. [Cited Aug 2000].
- [Ind97] Ambassador Karl Inderfurth. Speaking as U.S. Special Representative of the President and Secretary of State for Global Humanitarian Demining. In *Hidden Killers*, Dec 1997.
- [Int91] International Commission on Radiological Protection. *Publication 60*. Technical report, ICRP, 1991.
- [Jan96] B S G Janson. *Improving the Technology for Humanitarian Demining*. In IEE [IEE96], pages 11–15.
- [JK69] Johnson and Kotz. *Discrete Distributions*. Wiley Interscience, 1969.
- [Joy98a] V P Joynt. *Mobile Metal Detection: A field perspective*. In IEE [IEE98], pages 14–18. Video presentation accompanying paper.
- [Joy98b] V P Joynt. *Vehicles and Methods for Mine Survey and Demining*. In Barlow et al. [B⁺98], pages 39–49. Also published on Internet Website <http://www.hdic.jmu.edu>.
- [Kap63] Irving Kaplan. *Nuclear Physics*. Addison-Wesley series in nuclear science and engineering. Addison-Wesley, second edition, 1963. Library of Congress Catalog No 62-9402.
- [Kee96] Robert Keeley. *Added Value: The requirements of mine clearers and donors from new mine detection technologies*. In IEE [IEE96], pages 21–25.
- [Kee99] R Keeley. *Levels of Survey*. Posted on “Demining Network” Internet listserver network@mgm.org by A V Smith for R Keeley, Feb 17 1999. Access to list via Website <http://www.MgM.org/network.htm>.
- [Kee00] M N Keene. *Private Communication*. Discussion, Sep 2000, Sep 2000.

- [Kin97] Colin King. *Mine clearance... in the real world*. In Nicoud [Nic97], pages S2,1–S2,8.
- [Kin98a] Colin King. *Demining: Enhancing the Process*. In IEE [IEE98], pages 1–9.
- [Kin98b] Colin King, editor. *Jane's Mines and Mine Clearance Yearbook*. Jane's Information Systems, third edition, 1998. ISBN: 0 7106 1803 4.
- [Lar99] T Lardner. *Private Communication*. Discussion of demining requirements, Cambodia, Mar 1999.
- [LCR⁺98] H W Lefevre, M S Chmelik, R J Rasmussen, R M S Schofield, G E Sieger, and J C Overley. *Using a fast-neutron spectrometer system to candle luggage for hidden explosives. Can it be made practical for first-line airport use?* Internet Website <http://darkwing.uoregon.edu/lefevre/Atcity.html>, Feb 1998. [Cited Mar 2000].
- [Lev99] David Levy. *Useful Innovation - the MIT probe*. Posted on “Demining Network” Internet listserver network@mgm.org, 19 May 1999. Access to list via Website <http://www.MgM.org/network.htm>.
- [LF98] Otto Löhlein and Martin Fritzsche. *Classification of GPR Data for Mine Detection Based on Hidden Markov Models*. In IEE [IEE98], pages 96–100.
- [LKN96] J W Leonhardt, A Küster, and H Neff. *Two channel detector, combining neutron backscattering and active electro-magnetic metal detection*. In IEE [IEE96], pages 177–179.
- [LLN99a] LLNL. (Lawrence Livermore National Laboratory) *Landmine Bibliography*. Internet Website http://www.llnl.gov/landmine/landmine_bibliography.html, Sep 1999. [Cited Mar 2000].
- [LLN99b] LLNL. (Lawrence Livermore National Laboratory) *Landmine Who's Who*. Internet Website http://www.llnl.gov/landmine/landmine_whos_who.html, Sep 1999. [Cited Mar 2000].
- [LvH98] Peter Ličko and Š Havlík. *The BOZENA and Demining Flail System*. In Barlow et al. [B⁺98], pages 149–152. Also published on Internet Website <http://www.hdic.jmu.edu>.
- [M F00] M F Physics Corporation. *Model A-910/920 APSTNG Neutron Generators*. Internet Website <http://www.mfphysics.com/A-910-920.htm>, Mar 2000.
- [M95] Philip Mächler. *Detection Technologies for Anti-Personnel Mines*. Internet Website <http://diwww.epfl.ch/w3lami/detec/monterey951.html#6>, Apr 1995. [Cited Feb 2000] Based on a paper presented at the Symposium

- on Autonomous Vehicles in Mine Countermeasures, Monterey, April 4-6, 1995.
- [M⁺99] Gunter Mulack et al. *Humanitarian Mine Action Equipment Catalogue 1999*. CD-ROM, 1999. Published by German Federal Foreign Office, Berlin. Tel +49 1888-17-3098. E-mail: 300-1@auswaertigesamt.de.
- [MAI00] MAIC. Mine Action Information Center *Internet Website* <http://www.hdic.jmu.edu>, Mar 2000. Regularly updated.
- [Mar99] Ed. James E Mark. *Polymer Data Handbook*. Oxford University Press, 1999. ISBN 0 19 510789 6.
- [MCJ⁺98] John E McFee, Tom Cousins, Trevor Jones, Jean R Brisson, Terry Jamieson, Ed Waller, Francois Lemay, Harry Ing, Edward Clifford, and Barkley Selkirk. *Thermal neutron activation system for confirmatory non-metallic land mine detection*. In Dubey et al. [DHB98], pages 553–564.
- [McL99] S McLeod. *Private Communication*. Discussion of prodding at Kompong Thom, Cambodia, Mar 1999.
- [Men97] Menschen gegen Minen (MgM). *Demining Network*. Internet list-server network@mgm.org, Since 1997. Access to list via Website <http://www.MgM.org/network.htm>.
- [Men00] Menschen gegen Minen (MgM). *The MgM Systems*. Internet Website http://www.mgm.org/profile/01_0.html#systems, Jul 2000. [Cited Aug 2000].
- [MF85] Irwin Miller and John E Freund. *Probability and Statistics for Engineers*. Prentice-Hall, third edition, 1985. ISBN 0 13 711938 0.
- [MFS95] Bradley J Micklich, Charles L Fink, and Leonid Sagalovsky. *Transport Simulation and Image Reconstruction for Fast-neutron Detection of Explosives and Narcotics*. In Dubuisson and Harding [DH95], pages 33–44.
- [MH79] Alan Martin and Samuel A Harbison. *An Introduction to Radiation Protection*. Chapman and Hall, London, second edition, 1979. ISBN 0 412 16240 7.
- [Min] Mine Action Information Center. *Journal of Mine Action*. Internet Website <http://www.hdic.jmu.edu/hdic/journal/>. Published three times each year.
- [Min99a] Minelab Pty. *Military Products*. Internet Website <http://www.minelab.com.au/military.html>, Sep 1999. [Cited Mar 2000].

- [Min99b] Mines Action Canada. *Responding to Needs: Appropriate Technology for Community-based Humanitarian Demining*. Internet Website <http://www.minesactioncanada.com/competition%20/bkgroundeng.html>, Aug 1999. [Cited Feb 2000].
- [Mis98] Mission Knives Inc. *Titanium mine probes*, page 590. In King [Kin98b], 1998.
- [Mit00] Robert Mitchell. *Humanitarian Demining Multidisciplinary Mine Detection And Neutralization Systems Research*. Internet Website <http://www.umd.edu/~demining/>, Mar 2000.
- [MK95] T Gill Miller and R A Kraus. *Substance Identification using Neutron Transmission*. In Dubuisson and Harding [DH95], pages 14–24.
- [Nat89] National Radiological Protection Board. *Living with Radiation*. HMSO, London, fourth edition, 1989. ISBN 0 85951 320 3.
- [Neb97] G Nebbia. *Nuclear Technology in the Detection of Landmines*. Internet Website <http://www.uspid.dsi.unimi.it/proceed/cast97/nebbia.html>, 1997. [Cited Jan 2002].
- [Nic97] J-D Nicoud, editor. *SusDem '97 International Workshop in Sustainable Humanitarian Demining*, Zagreb, Croatia, 1997.
- [Nor95] Mark H North. *Chlorinated hydrocarbon sensor for cone penetrometer*. US Patent 5,416,320, May 1995.
- [NVE00] NVED. (U.S. Army Communications Electronics Command, Night Vision and Electronic Sensors Directorate, Countermining Division) *Humanitarian Demining Website: Raising Awareness to the Problems, Solutions, Effects, and Training Concerning Landmines and Humanitarian Demining*. Internet Website <http://www.demining.brtrc.com>, Mar 2000. Regularly updated.
- [Oxl95] Jimmie C Oxley. *Explosives Detection: Potential Problems*. In Dubuisson and Harding [DH95], pages 217–226.
- [Pek82] G Pekarsky. *Neutron Nondestructive Testing of Materials and Objects*. Doctor of Applied Sciences Dissertation, Moscow, 1982.
- [Pek98a] G Pekarsky. *Multisensor technology for buried land mines detection*. In IEE [IEE98], pages 147–151.
- [Pek98b] G Pekarsky. *Private Communications*. Discussions and written communications, Oct 1998.
- [PNBW70] D E Parks, M S Nelkin, J R Beyster, and N F Wikner. *Slow Neutron Scattering and Thermalization*. W A Benjamin Inc, New York, 1970.
- [Por99] Lisa J Porter. *Thermal neutron analysis in unexploded ordnance and mine detection*. In Doty [Dot99], pages 126–140.

- [Rah99a] Ghulam Rahman. *Private Communication*. Wall-chart of accident data at META headquarters, Jalalabad, Afghanistan, Aug 1999.
- [Rah99b] Ghulam Rahman. *Private Communication*. Discussions during visit to META headquarters, Jalalabad, Afghanistan, Aug 1999.
- [Ran00] J J Rant. ‘Results and conclusions of the 5th Explosive Ordnance Disposal (EOD) Conference’. *Insight*, 42(2):98–101, Feb 2000. Conference took place in Ljubljana, Slovenia, Sep 30 to Oct 1, 1999.
- [RD95] E Rhodes and C E Dickerman. *Advances in associated-particle neutron probe diagnostics for substance detection*. In Dubuisson and Harding [DH95], pages 2–13.
- [SAI99] SAIC Corp. *Ancore parcel/luggage-explosive detection system (PL-EDS)*. Internet Website http://www.pseag.org/Categories_%20HTML/Small_Package_Category/sld002.htm Mar 1999. [Cited Dec 1999].
- [San98] Sanoya Industry Co Ltd. *Krafton(TM) shielding material*. Internet Website <http://utuno.miya.or.jp/~sanoya01/krafton/indexe.htm>, 1998. [Cited Dec 1999].
- [SGR91] Z P Sawa, T Gozani, and P Ryge. *Contraband detection system using direct imaging pulsed fast neutrons*. US Patent 5,076,993, 1991.
- [Smi99] Andy Smith. *more bleeding handtools*. Posted on “Demining Network” Internet listserver network@mgm.org, May, 7 1999. Access to list via Website <http://www.MgM.org/network.htm>.
- [Smi00a] A V Smith. *Prodder (or Probe) for Soft Ground*. Internet Website <http://www.mech.uwa.edu.au/jpt/demining/tech/prodder/intro.html>, Jan 2000.
- [Smi00b] A V Smith. ‘The FACTS on protection needs in humanitarian demining’. *Journal of Mine Action*, 4(2), Jun 2000. Also published on internet Website <http://www.hdic.jmu.edu/hdic/journal/4.2>.
- [Smi00c] Andy Smith. *Database of demining incident victims*. CD-ROM available from A V Smith avs@landmines.demon.co.uk, 2000.
- [Sod98] Sodern. Soditron neutron tube. Product literature, 1998. 20 avenue Descartes, Boîte Postale 23, 94451 Limeil-Brévannes cedex, France.
- [SPBMS98] David A Sparrow, Lisa J Porter, Thomas J Broach, and Roshni J Mehta-Sherbondy. *Phenomenology of prompt gamma neutron analysis in the detection of mines and near-surface ordnance*. In Dubey et al. [DHB98], pages 545–552.
- [Sti86] Peter Stiff. *Taming the Landmine*. Galago, PO Box 404, Alberton, RSA, 1986. ISBN 0 947020 04 7.

- [TCC⁺99] Stacy Tantum, Leslie Collins, Lawrence Carin, Irina Gorodnitsky, Andy Hibbs, Dave Walsh, Geoff Burrell, Dave Gregory, Rob Matthews, and Stephanie Vierkötter. *Signal processing for NQR discrimination of buried landmines*. In Dubey et al. [D⁺99], pages 474–482.
- [Tow73] W N Townsend. *An Introduction to the Scientific Study of the Soil*. Edward Arnold (Publishers) Ltd, London, 5th edition, 1973. ISBN 0 7131 2407 5.
- [Tre97] J P Trevelyan. ‘Robots and Landmines’. *Industrial Robot*, 24(2):114–125, 1997.
- [Tre00a] J Trevelyan. *Force sensing prodder (version 1)*. Internet Website <http://www.mech.uwa.edu.au/jpt/demining/tech/prodder/uwa97.html>, Jan 2000. [Cited Mar 2000].
- [Tre00b] J Trevelyan. *Prodders*. Internet Website <http://www.mech.uwa.edu.au/jpt/demining/tech/prodder/intro.html>, Jan 2000.
- [Tre00c] J Trevelyan. *Water Jet Cutters*. Internet Website <http://www.mech.uwa.edu.au/jpt/demining/tech/projects.html>, Jan 2000. [Cited Mar 2000].
- [Tre00d] James P Trevelyan. *Technology needs for Humanitarian Demining*. Internet Website <http://www.mech.uwa.edu.au/jpt/demining/needs/intro-needs.html>, Feb 2000. Report can be downloaded as .pdf file from web page.
- [Tri95] V Tripăduş. ‘Prompt neutron-gamma analysis of coal by using Am-Be neutron source’. *Rom. Journ. Phys.*, 40(1):95–100, 1995. Bucharest.
- [Tul99] J K Tuli. *Thermal neutron capture gammas by nucleus*. Internet Website <http://www.nndc.bnl.gov/wallet/tnc/capgam.shtml>, 1999. [Cited Jan 2000] Brookhaven National Laboratory, USA.article.
- [Tur95] James E Turner. *Atoms, Radiation and Radiation Protection*. John Wiley and Sons, Inc, second edition, 1995. ISBN 0 471 59581 0.
- [Uni98] United Nations. *International Standards For Humanitarian Mine Clearance Operations*. Internet Website <http://www.un.org/Depts/Landmine/Standard/s-index.htm>, Jan 1998. [Cited March 2000].
- [Uni00] United Nations. *United Nations Mine Action Service*. Internet Website <http://www.un.org/Depts/dpko/mine/>, Mar 2000. Regularly updated.
- [UNM99a] UNMAS. (United Nations Mine Action Service) *Current Standards, Section Four: Minefield Marking*. Internet Website http://www.mineclearancestandards.org/chap_4_body.htm, Nov 1999. [Cited Jul 2000].

- [UNM99b] UNMAS. (United Nations Mine Action Service) *Current Standards, Section Three: Survey*. Internet Website http://www.mineclearancestandards.org/chap_3.htm, Nov 1999. [Cited Jul 2000].
- [US 95] US Dept of Environment. (U.S. Govt, Dept of Environment, Office of Science and Technology), *Moisture Sensor in Cone Penetrometer for In-Tank Characterization*. Internet Website http://www.cmst.org/cmst/Rainbow_95/2.7.html, Nov 1995. [Cited Dec 1999].
- [US 99] US Marine Corps. *Market Survey for Advance Mine Detection (AMD) Sensors*. Re-posted on “Demining Network” Internet listserver network@mgm.org by ardis@primenet.com, Jun, 8 1999. Original document was available from Internet Website <http://www.marcorsyscom.usmc.mil/mcsctq/index.html>.
- [UWA00] UWA. (University of Western Australia) *Demining Research at the University of Western Australia*. Internet Website <http://www.mech.uwa.edu.au/jpt/demining/Default.html>, Feb 2000. Regularly updated.
- [VCCP+99] G Viesti, M Cinausero, N Cufaro-Petroni, G D’Erasmus, D Fabris, V Filippini, E Fioretto, R Fonte, F Innocenti, M Lunardon, I Lazzizzera, S Moretto, G Nardelli, G Nardulli, G Nebbia, M Palomba, A Pantaleo, L Pappalardo, S Pesente, P Prati, G Prete, S Reito, A Sartori, G Tecchiolli, S Zavatarelli, and L Zuin. *The EXPLODET project: Advanced Nuclear Techniques for Humanitarian Demining: Progress Report 1998*. Internet Website http://inf.n.science.unitn.it/explodet/reports/expl_jan99/explojan99, Jan 1999. [Cited Jan 2000].
- [VLFM99] N L Vause, T R Letowski, L G Ferguson, and T J Mermagen. *Auditory issues in handheld land mine detectors*. In Dubey et al. [D⁺99], pages 778–786.
- [Vol98] R Voles. *Confidence in the assessment and use of mine detection systems*. In IEE [IEE98], pages 28–30.
- [Vol00] R Voles. *Private Communication*. Correspondance, Feb 2000.
- [VW00] George Vourvopoulos and P C Womble. *Pulsed Fast/Thermal Neutron Analysis: A Technique for Explosives Detection*. Internet Website <http://www.wku.edu/API/research/explo.htm>, Feb 2000. Paper can be downloaded from Website as .pdf file.
- [Wie98] G Wield. *Application of Ultrasound to Landmine Detection Probes*. Morgan Matroc Ltd, Transducer Products Division, Southampton SO19 7TG, England, Mar 1998.
- [Woo97] R Woodfin. *Chemical sensors: Classification of Mine-like objects by identification of explosives*. In Nicoud [Nic97], pages 331–334.

- [Wor83] World Meteorological Organization. *Neutron Probe for Soil Moisture Measurement, HOMS component C58.3.01*. Internet Website <http://www.wmo.ch/web/homs/c58301.html>, Nov 1983. [Cited Dec 1999].
- [Yam73] Taro Yamane. *Statistics, An introductory analysis*. Harper and Row, third edition, 1973. ISBN 06 047313 4.
- [Zak94] Paul Zakian. *Neutron Probe Moisture Sensors*. Internet Website <http://www.pnl.gov/WEBTECH/mwld/moistsen.html>, Sep 1994. [Cited Dec 1999].