



University of Warwick institutional repository: <http://go.warwick.ac.uk/wrap>

This paper is made available online in accordance with publisher policies. Please scroll down to view the document itself. Please refer to the repository record for this item and our policy information available from the repository home page for further information.

To see the final version of this paper please visit the publisher's website. Access to the published version may require a subscription.

Author(s): Sushama Murty

Article Title: Topology of utility possibility frontiers of economies with Ramsey taxation

Year of publication: 2009

Link to published article:

[http://www2.warwick.ac.uk/fac/soc/economics/research/papers\\_2009/terp\\_912b.pdf](http://www2.warwick.ac.uk/fac/soc/economics/research/papers_2009/terp_912b.pdf)

Publisher statement: None

Topology of utility possibility frontiers of economies  
with Ramsey taxation

Sushama Murty

No 912

**WARWICK ECONOMIC RESEARCH PAPERS**

**DEPARTMENT OF ECONOMICS**

THE UNIVERSITY OF  
**WARWICK**

# Topology of utility possibility frontiers of economies with Ramsey taxation

Sushama Murty\*

December 2009

I thank Charles Blackorby, Andrés Carvajal, Roger Guesnerie, David Mond, Herakles Polemarchakis, and participants of the CRETA Seminar Series at the University of Warwick.

\*Sushama Murty: Department of Economics, University of Warwick: [s.murty@warwick.ac.uk](mailto:s.murty@warwick.ac.uk)

## Abstract

We explore the scope of employing standard assumptions and replicating standard (Kuhn-Tucker-type) techniques that are used to study the first-best Pareto frontier to the study of Pareto frontiers of second-best economies. In the context of a simple second-best situation created by the inability of the government to implement personalized lump-sum transfers and where the government takes recourse to linear (Ramsey) commodity taxes as alternative redistributive devices, we identify at least three potential problems that second-best situations create for obtaining well-behaved Pareto frontiers. We show that additional conditions are required to ensure that the second-best Pareto frontier of an economy with  $H$  consumers will have the expected structure of a  $H - 1$ -dimensional manifold. Second-best Pareto optima, as is well-known, are characterized by consumption and/or production inefficiencies. In a class of private-ownership economies with Ramsey taxation, we show that, generically, while the jointly production and consumption inefficient component of the second-best Pareto manifold is a submanifold that also has a dimension equal to  $H - 1$ , the production efficient but consumption inefficient, consumption efficient but production inefficient, and the first-best components are lower dimensional, and hence negligible in size, submanifolds. Thus, we formally demonstrate that, generically, in second-best economies, *joint* production and consumption inefficiencies are prevalent and, hence, neither producer nor consumer prices reveal the true social shadow prices of resources. The recovery of unobservable shadow prices from observable data is crucial for cost-benefit analysis of competing public sector projects. Our results demonstrate the important need for further research for recovering the true social shadow prices from observable data in second-best economies.

*Journal of Economic Literature* Classification Number: H21, D50

*Keywords:* Ramsey taxation, second-best, production efficiency, general equilibrium, private ownership, differential topology, transversality theorem.

# Topology of utility possibility frontiers of economies with Ramsey taxation

by  
Sushama Murty

## 1. Introduction.

Second-best situations are created when there are constraints—informational, institutional, and behavioral—on the implementation of the second-welfare theorem. In such situations, the feasible states of the economy are the equilibria that can be obtained through the use of instruments and policies by the planner that are consistent with the constraints in the economy. The second-best equilibria are obtained by a Pareto ranking of feasible states in such constrained economies. A fundamental feature of second-best equilibria is that, generically, unlike in the first-best economies, all the prevailing (observable) market prices will not be indicative of the generally unobservable social value (the social shadow prices) of resources in the economy. Hence, if at a given status-quo, new opportunities (projects) for development arise, then the planner is confronted with the problem of computing the true social shadow prices in the economy for performing cost-benefit tests to judge the merits of and to choose between various competing projects.

Examples exist in the literature, however, of second-best situations where some market prices could still be used as perfect proxies for the social shadow prices of the resources. Where this is possible, this is a big help for cost-benefit exercises involving marginal public-sector projects. The Ramsey [1927]/Diamond and Mirrlees (DM) [1971] second-best model is one such example. In that model, a second-best situation arises because of the government's inability to implement personalized lump-sum transfers as required by the second-welfare theorem. In their absence the government uses linear commodity (Ramsey) taxes and uniform-lump-sum transfers as alternative, albeit second-best, means of redistribution or raising revenue. Commodity taxes draw a wedge between the prices the producers receive and the prices the consumers pay for goods, and hence create distortions in a competitive economy. In an economy characterized by such taxes and constant returns to scale, DM demonstrated that all second-best optimal allocations are production efficient, that is, the producer prices in the private competitive sector correctly reflect the social shadow prices in such economies. So, assuming that the planner chooses a status-quo that is second-best optimal, producer prices can be used in lieu of social shadow prices for cost-benefit analysis of public-sector projects that are available at the status-quo.<sup>1</sup>

The problem for cost-benefit exercises will remain for second-best models for which there exist second-best equilibria where none of the observable market prices reflect the unobservable social shadow prices in the economy. How likely is it to encounter such economies? In such economies, what is the generic size and structure of the set of second-best equilibria where market prices can be used in lieu of the shadow prices? These are

---

<sup>1</sup> See Dréze and Stern [1987] and Boadway [1975].

some of the questions that this paper aims to tackle in the context of a simple second-best model. These questions are important for, if the existence of such economies is more a rule than an exception and if the size of the set of second-best equilibria where market prices correctly reflect the social shadow prices is generically of measure zero, then we are led to further interesting and important questions: (i) what is the relationship between observable market prices and the social shadow prices in such economies? (ii) how can we recover social shadow prices from data in such economies? These, however, will be questions to be answered in future research projects.

The income distribution scheme in the DM model involves consumers receiving only endowment incomes. If this model is extended to allow for decreasing returns-to-scale in production (and hence the existence of positive profits) and if the consumers own shares in the pure profits of the firms (as in a Arrow-Debreu private-ownership economy), then the production efficiency result of DM is jeopardized.<sup>2</sup>

Though our analysis will be restricted to the study of this simple but more realistic extension of the DM model that allows for both production and consumption inefficiencies, we believe that the methodology that is developed in this paper is common to the understanding of generic results of most second-best models.<sup>3</sup> Moreover, to the extent commodity taxation is a current reality and is widespread in most economies, cost-benefit tests have to be conducted in the framework of distortions identified by Ramsey and DM.<sup>4</sup>

We employ the tools of differential topology to study the generic structure and size of the second-best frontiers of private-ownership economies with Ramsey taxation. These tools have been widely used in the study of the structure of equilibria in various contexts.<sup>5</sup> To the best of our knowledge the scope of these tools to study Pareto-frontiers of second-best economies has not been fully explored thus far. A study of the generic structure of the second-best frontiers of tax economies with one-hundred percent profit taxation was initiated by Guesnerie [1998], where he highlighted some of the difficulties in employing these tools to such a study. Precisely, his work demonstrates that difficulties arise on at least two counts: firstly, in such an analysis, the preferences of the consumers, expressed in the dual space of the policy instruments that parametrize tax equilibria, are generally

---

<sup>2</sup> Though it is known that second-best production efficiency continues to hold as long as the government can tax away pure profits at one-hundred percent and redistribute the proceeds as uniform-lumpsum transfers or if the government can implement firm-specific profit taxation (see Dasgupta and Stiglitz [1972], Mirrlees [1972], Hahn [1973], Sadka [1977], Guesnerie [1998], Reinhorn [2005], and Blackorby and Murty [2009]). The assumption that the government can have the power to implement such profit taxes seems unrealistic in mixed economies.

<sup>3</sup> Consumption inefficiencies imply that the consumer prices in tax economies are not reflective of the social shadow prices.

<sup>4</sup> Commodity taxation, which includes VAT, sales, excise, etc. taxes, is an important source of government revenue world-wide. VAT accounts for 20-percent of world's tax revenue and has been adopted in more than 130 countries. See Keen and Lockwood [2007].

<sup>5</sup> See, for example, Debreu [1970] and Balasko [1998] for their application to the case of competitive equilibria, see Geanakoplas and Polemarchakis [1986], Villanacci et al. [2002], and Carvajal and Polemarchakis [2009] for applications to the case of incomplete asset markets, see Guesnerie [1998] and Fuchs and Guesnerie [1983] for their application to the case of Ramsey tax equilibria.

non-convex. This leads to the usual problems associated with non-convexities, namely, discontinuities in the solution mapping of the optimization problem under consideration (here the second-best Pareto problem) and multiplicity of solutions.<sup>6</sup> Secondly, the literature on Ramsey taxation that emanated from the pioneering work of DM works with models in the dual space of the policy instruments. Though convenient for characterizing second-best optimal taxes, such models are not helpful for establishing generic comparative static results, as they do not easily allow a rich enough set of perturbations in the fundamentals (the data) of the economy. Given these two limitations, Guesnerie [1998] was able to study only the generic size of the set of *almost* second-best equilibria (these are tax equilibrium values of the government's policy variables where the first-order conditions of second-best Pareto optimality are almost satisfied).<sup>7</sup> As he points out, his characterization gives only an idea of the size and not the topological structure of the second-best Pareto optimal tax equilibria. Moreover, in his model with one-hundred percent profit taxation, all second-best are production efficient.

In this paper, we study tax economies in the space of both primal and dual variables. We borrow the modeling framework that has been used to study models of competitive equilibria in complete and incomplete markets by Geanakoplas and Polemarchakis (GP) [1986], Villanacci et al. (V et al.) [2002], Citana et al. (C et al.) [1998], and Carvajal and Polemarchakis (CP) [2009]. Such an approach allows us to identify a class of economies with a rich set of perturbations in the fundamentals that proves helpful in obtaining our generic results. In the class of economies that we study, economies differ with respect to the preferences of the consumers, the technologies of the firms, the endowment distribution, and the profit shares of consumers. Despite the non-convexities of the indirect preferences and the associated problems of multiplicity and discontinuity of the solution that have been identified by Guesnerie [1998], we identify conditions which allow a systematic study of the second-best frontier and its various subsets.

Our results are that, in the class of economies and under the conditions that we identify, generically, that is, for almost all of the economies in this class, except on a closed subset of measure zero, (i) the second-best Pareto (utility possibility) frontiers of private ownership economies with Ramsey taxation are manifolds whose dimension is  $H - 1$ , where  $H$  is the number of consumers and (ii) the production efficient but consumption inefficient, the consumption efficient but production inefficient, and the jointly production and consumption efficient (that, is the first-best) subsets of this manifold are lower dimensional submanifolds. These results demonstrate the prevalence of production and consumption inefficiencies, that is, in almost all economies with Ramsey taxation the subset of the second-best manifold where market prices can be used in lieu of social shadow prices is of measure zero. Since this is a generic property, the economies such as the ones in DM and Guesnerie [1998], where every second-best is production efficient, must have zero measure in our class of economies. Blackorby and Murty (BM) [2009] provide an example of an

---

<sup>6</sup> Guesnerie [1998] points out that results of the Zeckhauser-Weinstein [1974] type in the context of public goods, which were based on convexity assumption, cannot be expected in this context.

<sup>7</sup> In fact this characterization holds for the stationary values of the second-best problem. The actual solutions to the problem will be a subset of the set of stationary values.

economy where all the second-best equilibria, other than those that are also first-best, exhibit production and consumption inefficiencies.<sup>8</sup>

In Section 2, we provide two examples to motivate and provide the intuition behind our analysis. In Section 3, we construct the class of economies on which our analysis is based and define a tax equilibrium in the space of both dual and primal variables. In Section 4, we state the second-best Pareto problem and study the structure of the constraint set of this problem. We identify conditions under which the constraint qualification condition, required for applying the Lagrange/Kuhn-Tucker theorem, will hold for the second-best Pareto problem. In Section 5, we identify conditions that, despite the non-convexities and associated problems identified by Guesnerie [1998], will ensure that the second-best Pareto frontier will have the usual feature of a continuous  $H - 1$ -dimensional manifold. We also characterize production and consumption efficiencies in terms of the Lagrange multipliers of the second-best problem. We use this characterization in Sections 6, 7, 8, and 9, to show that, while the second-best jointly production and consumption inefficient subset of the second-best Pareto manifold is, generically, a  $H - 1$ -dimensional submanifold, the second-best production efficient but consumption inefficient, second-best consumption efficient but production inefficient, and the first-best subsets are lower dimensional (and hence negligible in size) components of the of the second-best Pareto frontier. In Section 10 we conclude. Proofs of our results are relegated to the appendix.

## 2. Preliminary notation and motivating examples.

There are  $N$  commodities indexed by  $k$ ,  $H$  consumers indexed by  $h$ , and  $I + 1$  firms indexed by  $i = 0, \dots, I$ . The firm indexed by zero is the public sector firm. For every firm  $i$ , the net output vector is denoted by  $y^i \in \mathbf{R}^N$ , and for every consumer  $h$  the gross consumption bundle is denoted by  $x^h \in \mathbf{R}_+^N$ . For every firm  $i$ , we define a mapping  $f^i : \mathbf{R}^N \rightarrow \mathbf{R}$  such that the production function of firm  $i$  is defined implicitly by the equation  $f^i(y^i) = 0$ . For every consumer  $h$ , the preferences are represented by a continuous function  $u^h : \mathbf{R}_+^N \rightarrow \mathbf{R}$  with image  $u^h(x^h)$ . Consumers face a price vector denoted by  $q \in \mathbf{R}_+^N$ , and private producers face a price vector denoted by  $p \in \mathbf{R}_+^N$ .<sup>9</sup> The uniform lump-sum transfer distributed by the government is denoted by  $R \in \mathbf{R}$ . The profit and supply functions of firm  $i \neq 0$  are denoted by  $\pi^i(p)$  and  $y^i(p)$ , respectively. The share of consumer  $h$  in the profits of firm  $i \neq 0$  is denoted by  $\theta_i^h > 0$ , with  $\sum_h \theta_i^h = 1$  for all  $i \neq 0$ . The public sector firm is behaviorally unconstrained and is free to choose any production vector from its technology. It collects the indirect taxes and uses the receipts to finance public sector production and to distribute uniform lump-sum transfers. The endowment vector of consumer  $h$  is denoted by  $e^h \in \mathbf{R}_{++}^N$ . Thus, the income of consumer  $h$  is  $R^h(q, p, R) = \sum_{i \neq 0} \theta_i^h \pi^i(p) + R + qe^h$ . Consumers maximize utility subject to their

<sup>8</sup> Note that the economies studied by DM and Guesnerie [1998] are special cases of our model where every consumer owns a share  $\frac{1}{H}$  in the profits of every firm (see BM).

<sup>9</sup> Thus, the vector of commodity taxes is  $q - p$ .



budget constraints. The indirect utility function and the demand function of consumer  $h$  are denoted by  $\gamma^h(q, R^h(q, p, R))$  and  $x^h(q, R^h(q, p, R))$ , respectively.

We now present two examples. These are not precise numerical examples. Rather, the spirit is to use them to provide some intuition of our analysis, to demonstrate some aspects of our methodology, and to give a flavor of our results.

*2.1. Example 1: nonconvexity of indirect preferences, discontinuities, and multiplicity of solutions.*

Consider an economy where  $H = 2$  and  $N = 2$ . Suppose there is no government production. The tax equilibrium conditions are given by the equation system<sup>10</sup>

$$\sum_h x^h(q, R^h(q, p, R)) = \sum_{i \neq 0} y^i(p) + \sum_h e^h. \quad (2.1)$$

These are two equations in five unknowns,  $q_1$ ,  $q_2$ ,  $p_1, p_2$ , and  $R$ . Note that the system is also homogeneous of degree zero in  $q$ ,  $p$ , and  $R$ . Hence, it admits one normalization, say,  $p_1 = 1$ . So, potentially, there are two degrees of freedom in choosing equilibria. Let us assume this is the case, so that, locally, around any equilibrium, we can solve for  $q_1$  and  $q_2$  in terms of  $p_2$  and  $R$ . We obtain functions  $q_k(p_2, R)$  for  $k = 1, 2$  that locally parametrize the tax equilibria around a given equilibrium. The indirect preferences, restricted to the space of variables that parametrize the tax equilibria, are easily obtained for  $h = 1, 2$  as  $\gamma^h(q(p_2, R), R^h(q(p_2, R), p_2, R))$ , which we rewrite as functions of  $p_2$  and  $R$ , namely,  $\Upsilon^h(p_2, R)$ . In general, nothing can be said about the properties of the functions  $\Upsilon^h$  in the space of  $p_2$  and  $R$ . There is no reason why such indirect preferences should be convex in this space. Guesnerie [1998] gives examples of economies where the indirect preferences are single peaked and non-convex. This means that cases like those in Figures 1, 2, and 3 are not ruled out.

Second-best optimal points are those that are obtained by maximizing consumer one's indirect utility holding the indirect utility of consumer two fixed at various levels. They lie on the two contract curves AB and CD in Figure 1 and in the shaded region in Figure 2. Both Figures 1 and 2 indicate the multiplicity of solutions to the second-best Pareto problem. In addition, Figure 3 demonstrates that discontinuities in the solution mapping of the second-best problem can also occur – though both curves AB and CD in Figure 3 indicate stationary values for the second-best problem, there is a discontinuity in the solution of the second-best problem when utility of consumer two switches from  $\bar{u}^2$  to  $\hat{u}^2$ . When this happens, the solution for  $\hat{u}^2$  level of utility lies only on curve CD.

Our analysis will demonstrate that cases such as Figure 2 are generically ruled out in the class of economies we will consider in the later sections. Solution to the second-best problem will generically be locally unique, that is, the solution mappings will be of the types shown in Figures 1 and 3. In addition, a systematic study of the structure of the second-best becomes possible if we assume that the solution mapping of the problem is also continuous, *e.g.*, as in Figure 1.

<sup>10</sup> As will be shown later, Walras law will imply that the government's budget is balanced at every tax equilibrium.

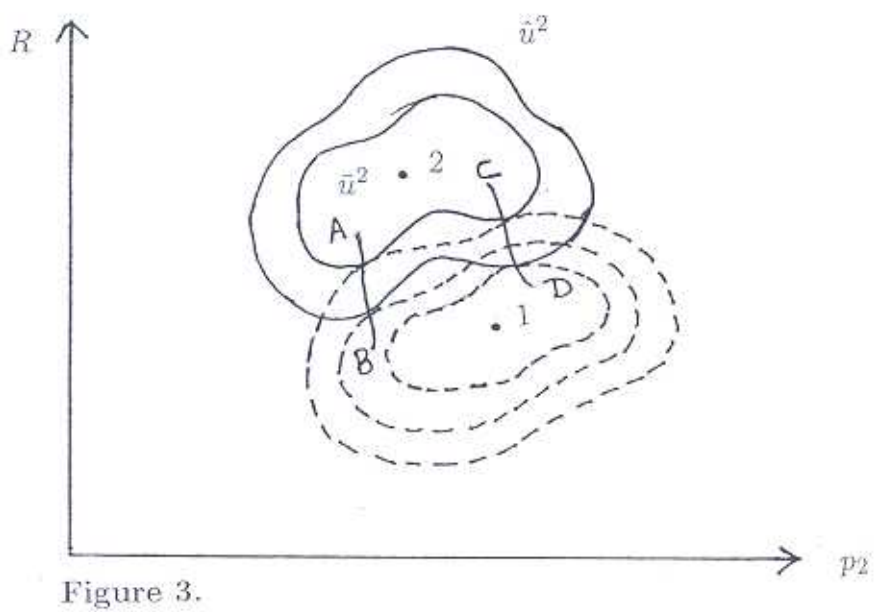
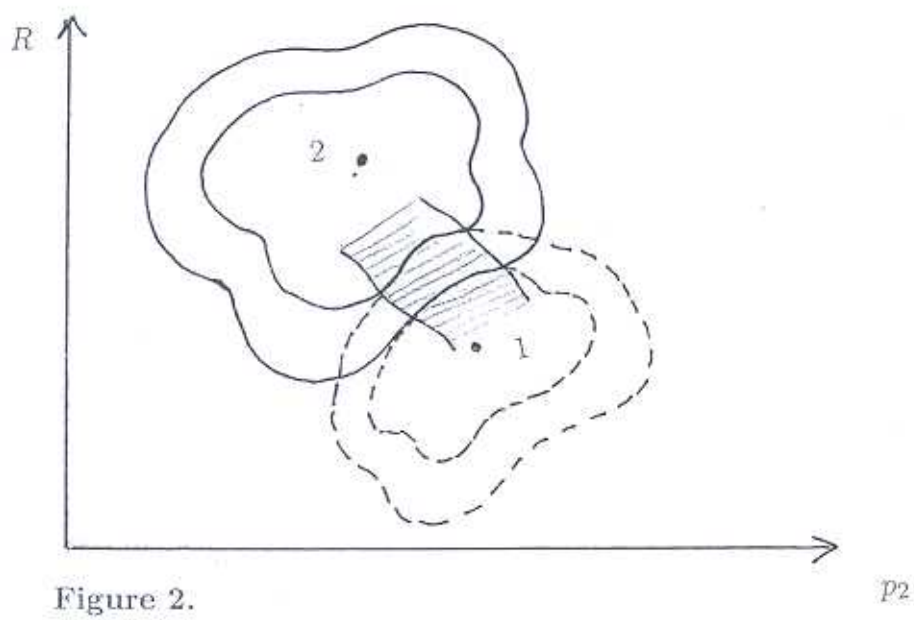
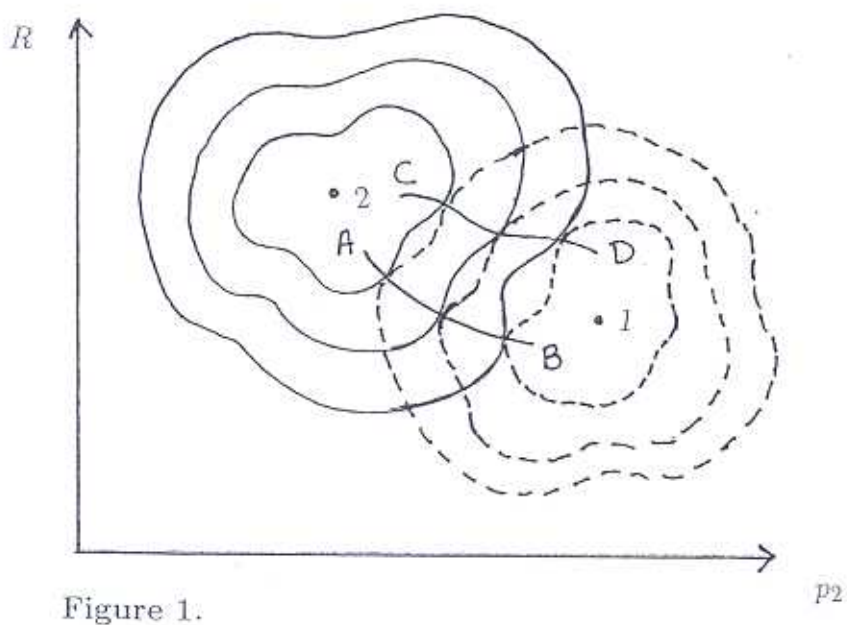

2.2. *Example 2: the size and structure of the second-best frontier.*

Consider an economy where  $H = 3$ ,  $I = 2$ ,  $N = 2$ , and with public sector production. For  $i \neq 0$ , the technology is defined by the production function

$$\begin{aligned} y_1^i &= \iota_i (y_2^i)^2 + v_i y_2^i, \quad y_2^i < \frac{-v_i}{2\iota_i} \\ &= \frac{-v_i^2}{4\iota_i}, \quad y_2^i \geq \frac{-v_i}{2\iota_i} \end{aligned}, \quad (2.2)$$

where the signs of the parameters are  $\iota_i < 0$ ,  $v_i > 0$ ,  $i = 1, 2$ . The technology of public firm is defined by the production function

$$y_1^0 = (y_2^0)^{0.5}. \quad (2.3)$$

For all  $h$ , the preferences of consumers are defined by

$$u^h = \vartheta_h \ln x_1^h + \varphi_h \ln x_2^h, \quad (2.4)$$

where the signs of the parameters are  $\vartheta_h > 0$  and  $\varphi_h > 0$ . For all  $h$ , the endowments of consumers are  $e_1^h = 0$  and  $e_2^h = 1$ . The income of consumer  $h$  is, hence,  $R^h(q, p, R) = \sum_{i \neq 0} \theta_i^h \pi^i(p) + R + qe_h$ . For all  $i \neq 0$ , the supply and profit functions are  $y_1^i(p) = \frac{(p_2 - v_i)^2}{4\iota_i} + \frac{v_i(p_2 - v_i)}{2\iota_i}$  and  $y_2^i(p) = \frac{(p_2 - v_i)}{2\iota_i}$ ,  $\pi_i(p) = \frac{(p_2 - v_i)^2}{-4\iota_i}$ . The demand functions of consumer  $h$  are  $x_1^h(q, R^h(q, p, R)) = \frac{\vartheta_h R^h(q, p, R)}{q_1}$  and  $x_2^h(q, R^h(q, p, R)) = \frac{\varphi_h R^h(q, p, R)}{q_2}$ . A tax equilibrium is defined by the system of equations

$$\begin{aligned} \sum_h \frac{\vartheta_h R^h(q, p, R)}{q_1} &= \sum_{i \neq 0} \left[ \frac{(p_2 - v_i)^2}{4\iota_i} + \frac{v_i(p_2 - v_i)}{2\iota_i} \right] + y_1^0, \\ \sum_h \frac{\varphi_h R^h(q, p, R)}{q_2} &= - \sum_{i \neq 0} \frac{(p_2 - v_i)}{2\iota_i} - y_2^0 + 3, \quad \text{and} \\ y_1^0 &= (y_2^0)^{0.5}. \end{aligned} \quad (2.5)$$

These are three equations in seven unknowns—  $q_1, q_2, p_1, p_2, y_1^0, y_2^0$ , and  $R$ . Because of the homogeneity properties of the demand and supply functions, the equation system is homogeneous of degree zero in  $q$ ,  $p$ , and  $R$ . So it admits one normalization, say,  $p_1 = 1$ . This implies that there are potentially three degrees of freedom in choosing equilibria. It is easy to check that, in this example, this is indeed the case and we can solve for the variables  $q_1, q_2$ , and  $y_1^0$  in terms of  $p_2, y_2^0$ , and  $R$  to obtain functions  $q_1(p_2, y_2^0, R)$ ,  $q_2(p_2, y_2^0, R)$ , and  $y_1^0(p_2, y_2^0, R)$  that globally parametrize the tax equilibria. As in the above example, these functions can then be used to derive the indirect preferences of the consumers in the space

of  $p_2$ ,  $y_2^0$ , and  $R$ . Denote the indirect preference of consumer  $h$  by  $\Upsilon^h(p_2, y_2^0, R)$ . The second-best Pareto problem can be written as

$$\begin{aligned} \mathcal{V}(u^2, u^3) &:= \max_{p_2, y_2^0, R} \Upsilon^1(p_2, y_2^0, R) \\ &\text{subject to} \\ \Upsilon^h(p_2, y_2^0, R) &\geq u^h, \quad h = 2, 3. \end{aligned} \tag{2.6}$$

The Lagrangian of the problem is

$$L(u^2, u^3, p_2, y_2^0, R, \alpha^2, \alpha^3) = \Upsilon^1(p_2, y_2^0, R) - \sum_{h=2}^3 \alpha^h [u_h - \Upsilon^h(p_2, y_2^0, R)], \tag{2.7}$$

where  $\alpha^2$  and  $\alpha^3$  are the Lagrange multipliers of the problem. The first-order conditions are given by

$$\Gamma(u^2, u^3, p_2, y_2^0, R, \alpha^2, \alpha^3) = 0, \tag{2.8}$$

where  $\Gamma : \mathbf{R}_+ \times \mathbf{R}^6 \rightarrow \mathbf{R}^5$  is defined by the functions

- (i)  $\frac{\partial L(u^2, u^3, p_2, y_2^0, R, \alpha^2, \alpha^3)}{\partial p_2}$
- (ii)  $\frac{\partial L(u^2, u^3, p_2, y_2^0, R, \alpha^2, \alpha^3)}{\partial y_2^0}$
- (iii)  $\frac{\partial L(u^2, u^3, p_2, y_2^0, R, \alpha^2, \alpha^3)}{\partial R}$
- (iv)  $\Upsilon^2(p_2, y_2^0, R) - u^2$
- (v)  $\Upsilon^3(p_2, y_2^0, R) - u^3$

These are thus five equations in five endogeneous variables  $p_2, y_2^0, R, \alpha^2$ , and  $\alpha^3$  and two exogeneous variables  $u^2$  and  $u^3$ . Let the mapping that solves (2.8) be denoted by  $\Phi : \mathbf{R}^2 \rightarrow \mathbf{R}^5$  with image  $\Phi(u^2, u^3) = \langle p_2, y_2^0, R, \alpha^2, \alpha^3 \rangle$ . This is the map that identifies the stationary values and the associated Lagrange multipliers of Problem (2.6), and  $\Gamma^{-1}(0)$  is the graph of  $\Phi$ .

Generically, that is, for almost all economies in the class of economies that we study in the next sections, we find that  $\Phi$  is locally unique and continuous. These properties of  $\Phi$  are established by first partitioning the set  $\Gamma^{-1}(0)$  into four subsets and establishing generic local uniqueness and continuity of the mapping  $\Phi$  in each of the subsets. These four subsets correspond to the following components of  $\Gamma^{-1}(0)$ : (a) the production and consumption inefficient component, (b) the production efficient but consumption inefficient component, (c) the production inefficient but consumption efficient component, and (d) the production and consumption efficient (the first-best) component.

These components are derived in the following manner. In Section 5.2, we show that, at a second-best, the social shadow prices of the resources are reflected in the shadow prices of the public sector. In our case, given the production function of the public sector in (2.3), these are given by the gradient vector  $\langle 1, 0.5(y_2^0)^{-0.5} \rangle$ . Production efficiency, thus, implies the proportionality of the private-sector producer prices and the public-sector shadow

prices at the second-best. Since  $p^1$  is normalized to one, this implies that, at a production efficient second-best, we have the condition

$$p_2 = 0.5(y_2^0)^{-0.5} \quad (2.9)$$

holding, *in addition to* (2.8). Similarly consumption efficiency requires the proportionality of the consumer prices and the public sector shadow prices at the second-best, which amounts to the condition

$$\frac{q_2(p_2, R, y_2^0)}{q_1(p_2, R, y_2^0)} = 0.5(y_2^0)^{-0.5} \quad (2.10)$$

holding at a consumption efficient second-best, *in addition to* (2.8).

Component (a) of  $\Gamma^{-1}(0)$  is obtained by solving (2.8) with values of  $p_2, R, y_2^0, \alpha^2$  and  $\alpha^3$  such that (2.9) and (2.10) do not hold. We show in Section 6 that, generically, in the class of economies that we consider, in this component of  $\Gamma^{-1}(0)$ , the mapping  $\Phi$  is locally unique and continuous, so that this component of  $\Gamma^{-1}(0)$  can be parametrized by  $u^2$  and  $u^3$ . Hence, it is, generically, a manifold of dimension  $H - 1$  (two in this example).

Component (b) of  $\Gamma^{-1}(0)$  is derived by solving equations (2.8) and (2.9) simultaneously. Note these are six equations in five endogenous variables. In general this system cannot be solved unless one of the exogenous variables, say  $u^3$  is converted into an endogeneous variables. This is equivalent to losing a degree of freedom in finding solution to (2.8), as the solution also needs to satisfy condition (2.9). We show in Section 7 that, when this is done, then, generically, we can solve for  $p_2, R, y_2^0, u^3, \alpha^2$ , and  $\alpha^3$  in terms of  $u^2$  and the solution is locally unique and continuous. In particular, let  $u^3 = u^3(u^2)$ . The production efficient component of  $\Gamma^{-1}(0)$  can thus be parametrised by the exogenous variable  $u^2$ . Hence, the production efficient component of  $\Gamma^{-1}(0)$  is a manifold of dimension  $H - N$  (one in this example). Thus, along the curve  $\langle u^2, u^3(u^2) \rangle$  in the parameter space defined by  $u^2$  and  $u^3$ , the stationary points of Problem (2.6) are  $\Phi(u^2, u^3(u^2))$ .<sup>11</sup>

Component (c) of  $\Gamma^{-1}(0)$  is similarly derived in Section 8 by solving equations (2.8) and (2.10) simultaneously and is, generically, a manifold of dimension  $H - N$  (one in this example).

Component (d) of  $\Gamma^{-1}(0)$  is derived in Section 9 by solving equations (2.8), (2.9), and (2.10) simultaneously. However, in our analysis, we find that (2.9) and (2.10) together imply the first order condition  $\frac{\partial L(u^2, u^3, p_2, y_1^0, R, \alpha^2, \alpha^3)}{\partial R} = 0$ . Thus, (2.8), (2.9), and (2.10) reduce to six equations in five endogeneous variables. To solve this system, we have to convert one of the exogenous variables  $u^2$  or  $u^3$  into an endogeneous variable, and we are

<sup>11</sup> Actually, as will be seen, Component (b) of  $\Gamma^{-1}(0)$  is, generically, either a manifold of dimension  $H - N$  or a manifold of dimension  $H - I$ .

left with one degree of freedom for moving in the first-best subset of  $\Gamma^{-1}(0)$ , which is, hence, a manifold of dimension one.<sup>12</sup>

Note, however, that  $\Phi$  is the mapping of only the stationary values of Problem (2.6). The actual solution mapping, which we denote by  $\overset{*}{\Phi}$ , will be a subset of  $\Phi$  at every parameter vector  $\langle u^2, u^3 \rangle$ . Since, generically,  $\Phi$  is locally unique, so is  $\overset{*}{\Phi}$ . However, in our analysis, we cannot, in general, establish local continuity of the mapping  $\overset{*}{\Phi}$ . The reason being the non-convexities of the indirect preferences. The intuition lies in the case seen in Figure 3, where  $\Phi$  corresponds to both the curves AB and CD, while  $\overset{*}{\Phi}$  corresponds to curve CD and only a part of curve AB. However, we show that, despite the discontinuities in the mapping  $\overset{*}{\Phi}$ , the value function  $\mathcal{V}(u^2, u^3)$  of Problem (2.6) is, generically, continuous, so that the second-best Pareto frontier (or the second-best utility possibility frontier), which is the set

$$U := \{ \langle u_1, u_2, u_3 \rangle \in \mathbf{R}^3 \mid u^1 = \mathcal{V}(u^2, u^3) \}, \quad (2.11)$$

is a manifold of dimension  $H - 1$  (two in this example) in the space of  $u^1$ ,  $u^2$ , and  $u^3$ .

If we assume that the mapping  $\overset{*}{\Phi}$  is also locally continuous then, generically, we show in Sections 6 to 9 that homeomorphisms can be established between each of the four components of  $\Gamma^{-1}(0)$  restricted to the graph of  $\overset{*}{\Phi}$  and appropriate subsets of the second-best Pareto manifold in the utility space. Hence, each of these four cases corresponds to a submanifold of appropriate dimensions of the second-best utility possibility manifold. Figure 4, where  $\overset{*}{\Phi}$  is assumed to be locally unique and continuous, is a stylized diagram to illustrate this point. The mapping  $\zeta$  in the figure is a local homeomorphism between the graph of  $\overset{*}{\Phi}$  and the second-best utility possibility frontier. Its restriction, for example, to the production inefficient but consumption efficient component  $de$  of the graph of  $\overset{*}{\Phi}$  implies that its image  $gh$  is a lower dimensional (in this case, of dimension one) submanifold of the second-best utility possibility frontier.

---

<sup>12</sup> Intuitively, as will be seen in Section 5.2, when (2.9) and (2.10) hold in addition to (2.8), then we are at a tax equilibrium where all the first order conditions for a first-best Pareto optimum are met. We can interpret this to be a tax equilibrium in a regime with personalized lump-sum transfers  $R^1$ ,  $R^2$ , and  $R^3$  (which consumers receive in addition to  $R$ ), where these transfers are fixed at values zero. Since this is a tax equilibrium where first-order conditions for a first-best hold, we find that, starting at such a tax equilibrium, the welfare gains from introducing non-zero personalized lump-sum transfers are zero, that is,  $\frac{\partial L(u^2, u^3, p_2, y_1^0, R, R^1, R^2, R^3, \alpha^2, \alpha^3)}{\partial R^h} = \frac{\partial \mathbf{Y}^h(p_2, y_1^0, R+R^h)}{\partial R^h} = 0$  for all  $h$ . Further, for every consumer, the welfare gain from introducing a personalized lump-sum transfer is the same as the welfare gain from a marginal change in  $R$ , that is,  $\frac{\partial \mathbf{Y}^h(p_2, y_1^0, R+R^h)}{\partial R^h} = \frac{\partial \mathbf{Y}^h(p_2, y_1^0, R+R^h)}{\partial R}$ , and hence  $\frac{\partial \mathbf{Y}^h(p_2, y_1^0, R+R^h)}{\partial R} = 0$  for all  $h$ . This implies that  $\frac{\partial L(u^2, u^3, p_2, y_1^0, R, R^1, R^2, R^3, \alpha^2, \alpha^3)}{\partial R} = 0$  at such a tax equilibrium.

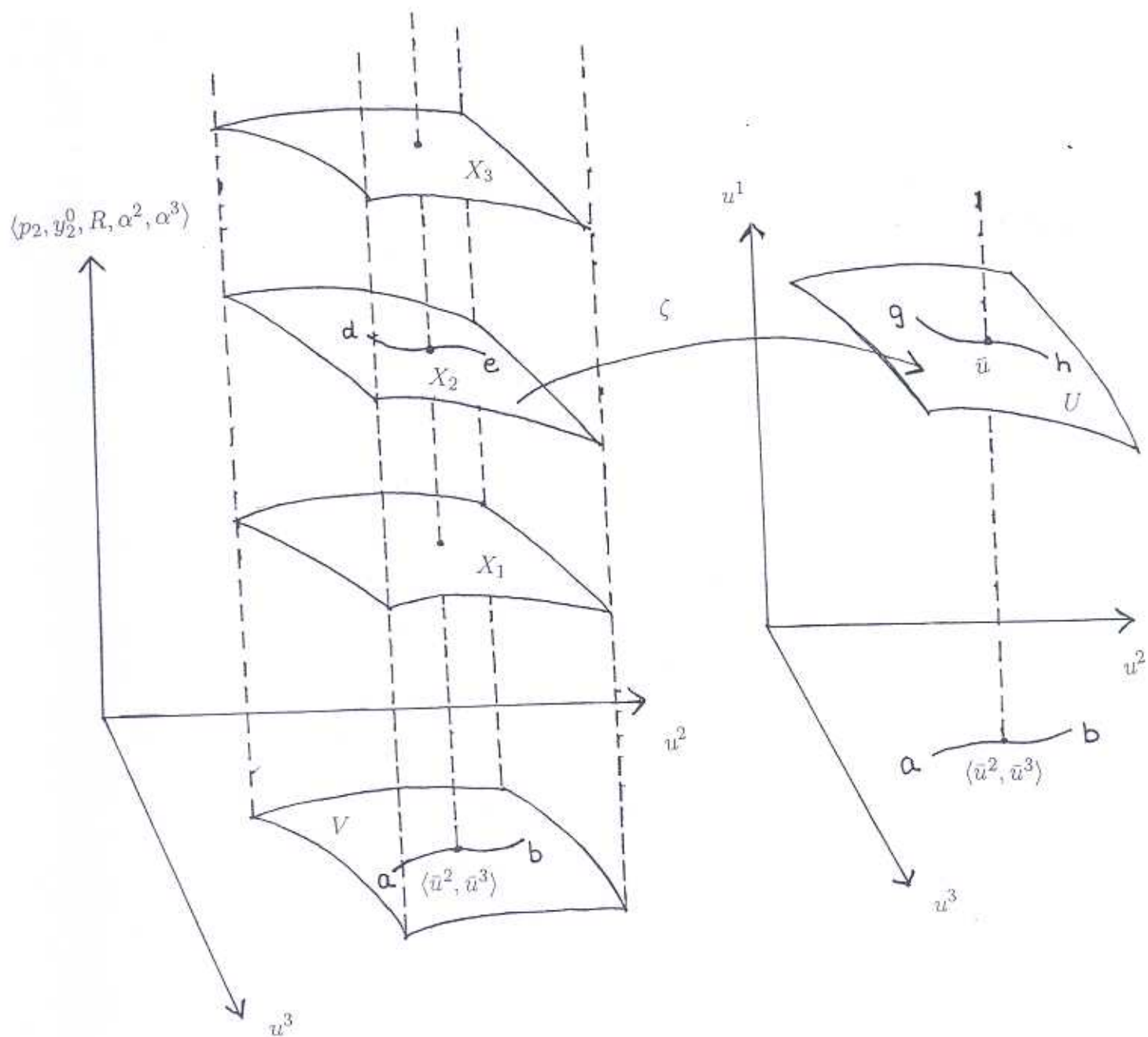

**Figure 4.**

Graph of  $\Phi$  restricted to  $V$  is  $X_1 \cup X_2 \cup X_3$ ,

Graph of  $\Phi^*$  restricted to  $V$  is  $X_2$ ,

$\zeta : X_2 \rightarrow \zeta(X_2) =: U$ ,

$\bar{u} = \langle \bar{u}^2, \bar{u}^3, \mathcal{V}(\bar{u}^2, \bar{u}^3) \rangle$ .

### 3. A class of private ownership economies with Ramsey taxation and the definition of a tax equilibrium.

We first define a benchmark economy  $E$ . The class of private ownership economies  $\mathcal{E}$ , which we use for our analysis, is derived by perturbing economy  $E$ . The technologies, preferences, and endowments in economy  $E$  are as follows. For every firm  $i$ , the function  $f^i$  is smooth with  $\nabla_y f^i \gg 0$ ,  $\nabla_{yy}^2 f^i$  positive definite, and the asymptotic cone of the set  $\{y \in \mathbf{R}^N | f^i(y) = 0\}$  is  $\mathbf{R}_-^N$ . The technology of firm  $i$  is defined by the set  $Y^i = \{y^i \in \mathbf{R}^N | f^i(y^i) \leq 0\}$ .  $Y^i$  contains  $\mathbf{R}_-^N$  and satisfies irreversibility. For every consumer  $h$ , the consumption set is  $\mathbf{R}_+^N$ ,  $u^h$  is smooth on  $\mathbf{R}_{++}^N$  with  $\nabla_x u^h \gg 0$  and  $\nabla_{xx}^2 u^h$  negative definite, and the closure of the indifference curves of  $u^h$  do not intersect the boundaries of  $\mathbf{R}_+^N$ . The aggregate endowment vector of the economy is denoted by  $\bar{e} \in \mathbf{R}_{++}^N$  and the distribution of endowments is  $(\bar{e}^h) \in \mathbf{R}_{++}^{HN}$ .<sup>13</sup>

**Definition.** A feasible allocation of  $E$  is a tuple  $\langle (x^h)_h, (y^i)_i \rangle \in \mathbf{R}_+^{HN} \times \mathbf{R}^{(I+1)N}$  such that  $y^i \in Y^i$  for all  $i$  and

$$\sum_h x^h = \sum_i y^i + \bar{e}. \quad (3.1)$$

The set of all feasible allocations of  $E$  is denoted by  $S$ .

**Remark E1.** Under the assumptions made above  $S$  is non-empty and compact.<sup>14</sup>

Pick  $\bar{s} = \langle (\bar{x}^h)_h, (\bar{y}^i)_i \rangle \in S$  such that  $\bar{x}^h \gg 0$  for all  $h$ . To derive the class of private ownership economies  $\mathcal{E}$  from  $E$ , we follow GP, C et al, and CP.<sup>15</sup> First, for each  $h$  and  $i$ , the functions  $u^h$  and  $f^i$  are perturbed so that the new utility and the production functions obtained from these perturbations differ from  $u^h$  and  $f^i$  only in open neighborhoods  $N_\epsilon(\bar{x}^h)$  and  $N_{\epsilon'}(\bar{y}^i)$  of their respective domains for some  $\epsilon$  and  $\epsilon'$  greater than zero.<sup>16</sup> Next, for each  $h$  and  $i$ , the consumption set and the domain of the (perturbed) production function in the new class of economies are restricted to be  $N_\epsilon(\bar{x}^h)$  and  $N_{\epsilon'}(\bar{y}^i)$ , respectively.

The new utility functions are obtained by perturbing  $u^h$  in its first and second-order derivatives evaluated at  $\bar{x}^h$ , while the new production functions are obtained by perturbing  $f^i$  in its zero<sup>th</sup>, first, and second-order derivatives evaluated at  $\bar{y}^i$ .  $\epsilon$ ,  $\epsilon'$ , and the perturbations can be chosen small enough such that the new functions retain the monotonicity and curvature properties of the original functions over their entire domains of definition. Such perturbations in the function  $u^h$  are illustrated in Figure 5, where the dotted indifference curves are obtained by perturbing the bold indifference curve.

<sup>13</sup> Given  $a^h \in \mathbf{R}^N$  for  $h = 1, \dots, H$ , the notation  $(a^h)$  denotes the vector  $\langle a^1, \dots, a^H \rangle \in \mathbf{R}^{HN}$ .

<sup>14</sup> See Debreu [1959].

<sup>15</sup> We refer you to these articles for all the details on the construction of  $\mathcal{E}$ .

<sup>16</sup>  $N_\epsilon(\bar{x}^h)$  denotes the  $\epsilon$  neighborhood around  $\bar{x}^h$ .



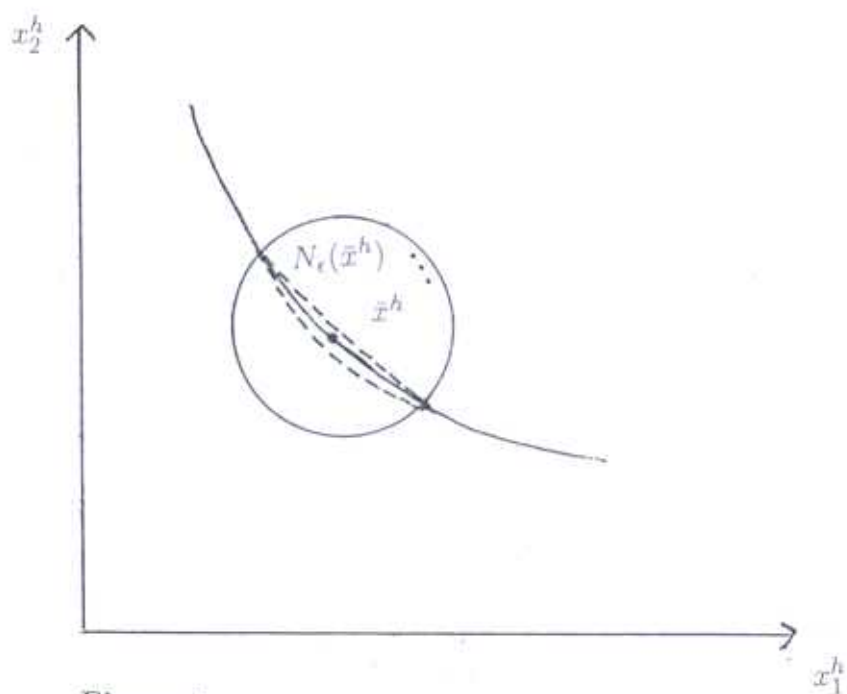

Figure 5.

As in CP, we employ a bump function to define the perturbed functions. For every  $\epsilon > 0$ , a bump function is defined as a mapping  $\simeq_\epsilon: \mathbf{R}^N \rightarrow \mathbf{R}$  with image

$$\begin{aligned} \simeq_\epsilon(x) &= 1 \text{ if } |x| < \epsilon \\ &= 0 \text{ if } |x| > 2\epsilon. \end{aligned} \quad (3.2)$$

Let  $\mathcal{M} \subset \mathbf{R}^{\frac{N(N+1)}{2}}$  denote the set of all symmetric  $N \times N$  matrices. For every  $h$  and  $x^h \in \mathbf{R}_{++}^N$ , there exist an open neighborhood of matrices  $\mathbf{M}_u^h \subset \mathcal{M}$  around the null matrix and an open neighborhood  $N_{\epsilon_u}(0) \subset \mathbf{R}^N$  such that for every  $A \in \mathbf{M}_u^h$  and  $a \in N_{\epsilon_u}(0)$ , we have  $\nabla_x u^h(x^h) + a + Ax^h \gg 0$  and  $\nabla_{x,x}^2 u^h(x^h) + A$  is negative definite.<sup>17</sup> Similarly, for every  $i$  and for every  $y^i \in \mathbf{R}^N$ , there exist an open neighborhood of matrices  $\mathbf{M}_f^i \subset \mathcal{M}$  around the null matrix, an open neighborhood  $N_{\epsilon_f}(0) \subset \mathbf{R}^N$ , and an open neighborhood  $N_b(0) \subset \mathbf{R}$  such that for every  $B \in \mathbf{M}_f^i$ ,  $b \in N_{\epsilon_f}(0)$ , and  $b_0 \in N_b(0)$ , we have  $b + By^i \gg 0$  and  $\nabla_{y,y}^2 f^i + B$ , is positive definite.<sup>18</sup>

Employing such perturbations and the bump function, we find that there exist (i)  $\epsilon_u > 0$  and  $\epsilon_f > 0$ , (ii) an open neighborhood of matrices  $\mathbf{M}_u \subset \mathcal{M}$  around the null matrix, (iii) an open neighborhood of matrices  $\mathbf{M}_f \subset \mathcal{M}$  around the null matrix, (iv)  $b > 0$ , and (v)  $\epsilon > 0$  and  $\epsilon' > 0$  such that (i')  $N_\epsilon(\bar{x}^h) \subset \mathbf{R}_{++}^N$  for all  $h$ , (ii')  $N_{\epsilon'}(\bar{y}^i) \subset \mathbf{R}^N$  for all  $i$ , (iii') for all  $h$ , if  $U$  is in the set of functions

$$\begin{aligned} \mathcal{U}^h := \{ & U : \mathbf{R}_+^N \times N_{\epsilon_u}(0) \times \mathbf{M}_u \rightarrow \mathbf{R} \mid U(x, a, A) = \\ & u^h(x) + \simeq_\epsilon(x - \bar{x}^h)[a^T(x - \bar{x}) + (x - \bar{x}^h)^T A(x - \bar{x}^h)] \}, \end{aligned} \quad (3.3)$$

then  $\nabla_x U \gg 0$ , and  $\nabla_{x,x} U$  is negative definite, and (iii') for all  $i$ , if  $F$  is in the set of functions

$$\begin{aligned} \mathcal{F}^i := \{ & F : \mathbf{R}^N \times N_b(0) \times N_{\epsilon_f}(0) \times \mathbf{M}_f \rightarrow \mathbf{R} \mid F(y, b_0, b, B) = \\ & f^i(y) + \simeq_{\epsilon'}(y - \bar{y}^i)[b_0 + b^T(y - \bar{y}^i) + (y - \bar{y}^i)^T B(y - \bar{y}^i)] \}, \end{aligned} \quad (3.4)$$

then  $\nabla_y F \gg 0$ , and  $\nabla_{y,y} F$  is positive definite.<sup>19</sup>

Each private ownership economy in  $\mathcal{E}$  is characterised as follows:

1. For each consumer  $h$ , the consumption set is  $\mathcal{X}^h = N_\epsilon(\bar{x}^h)$  and the preferences are given by the restriction of a utility function  $U^h(\cdot, a^h, A^h) \in \mathcal{U}^h$  to the consumption space  $\mathcal{X}^h$ .
2. For every firm  $i$ , the production function is given by the restriction of  $F^i(\cdot, b_0^i, b^i, B^i) \in \mathcal{F}^i$  to  $N_{\epsilon'}(\bar{y}^i)$ . The technology of firm  $i$  is  $\mathcal{Y}^i = \{y^i \in N_{\epsilon'}(\bar{y}^i) \mid F^i(\cdot, b_0^i, b^i, B^i) \leq 0\}$ .

<sup>17</sup> The existence follows from the continuity of the first and second derivatives of  $u^h$ .

<sup>18</sup> Although, so far we have placed no restrictions on  $b$ , which defines the limits for the perturbations in the zero<sup>th</sup> order derivative of  $f^i$ , later we will assume a value for  $b$  that will ensure that the profits of private firms in the perturbed economies remain positive as in the original economy.

<sup>19</sup> Note, since  $H$  and  $I$  are finite,  $\epsilon_u$ ,  $\epsilon_f$ ,  $\epsilon$ ,  $\epsilon'$ , and  $b$  have been taken to be independent of  $h$  and  $i$ . If such such scalars were consumer or firm specific then, for example, we could choose  $\epsilon_u = \min_{h=1, \dots, H} \{\epsilon_u^h\}$ .

3. A  $(H \times I)$  matrix of profit shares denoted by  $\Theta$ , with typical element  $\theta_i^h$  such that  $\langle \theta_i^1, \dots, \theta_i^H \rangle \in \Delta_{H-1}$  for all  $i \neq 0$ .<sup>20</sup>
4. The aggregate endowment  $e$  is such that its distribution  $(e^h)$  lies in  $N_\eta((\bar{e}^h)) \subset \mathbf{R}_{++}^{HN}$ , where  $\eta > 0$ .

Define  $\Omega := [N_{\epsilon_u}(0) \times \mathbf{M}_u]^H \times [N_b(0) \times N_{\epsilon_f}(0) \times \mathbf{M}_f]^{I+1}$  and  $W = N_\eta((\bar{e}^h)) \times \Delta_{H-1}$ .<sup>21</sup>

The vector of characteristics that characterizes an economy in  $\mathcal{E}$  is denoted by  $\langle w, \omega \rangle$ , where  $w = \langle (e^h), \Theta \rangle \in W$  and  $\omega = \langle (a^h), (A^h), (b_0^i), (b^i), (B^i) \rangle \in \Omega$ . We denote the vector  $\langle w, \omega \rangle$  by  $r$  and the set  $W \times \Omega$  by  $\mathcal{R}$ . An economy in  $\mathcal{E}$  corresponding to  $r \in \mathcal{R}$  is denoted by  $\mathcal{E}(r)$ .

**Definition.** For every  $r \in \mathcal{R}$ , a feasible allocation of  $\mathcal{E}(r)$  is a tuple  $\langle (x^h)_h, (y^i)_i \rangle \in \mathbf{R}_+^{HN} \times \mathbf{R}^{(I+1)N}$  such that  $y^i \in \mathcal{Y}^i$  for all  $i$  and  $x^h \in \mathcal{X}^h$  for all  $h$  and

$$\sum_h x^h = \sum_i y^i + \sum_h e^h. \quad (3.5)$$

The set of all feasible allocations of  $\mathcal{E}(r)$  is denoted by  $\mathcal{S}(r)$ .

**Remark E2.**  $\eta > 0$  is chosen such that for all  $r \in \mathcal{R}$ ,  $\mathcal{S}(r)$  is non-empty. In that case,  $\mathcal{S}(r)$  is compact for all  $r \in \mathcal{R}$ .

### 3.1. Tax equilibria.

We follow the approach of V et al. and CP in defining equilibrium of an economy in  $\mathcal{E}$ . This approach employs both the primal and dual variables.

**Definition.** Let  $r \in \mathcal{R}$ . A tax equilibrium of the economy  $\mathcal{E}(r)$  is a configuration  $\langle (x^h), (y^i), p, q, R, (\lambda^h), (\gamma^i)_{i \neq 0} \rangle \in \mathbf{R}_{++}^{HN} \times \mathbf{R}^{(I+1)N} \times \mathbf{R}_{++}^{2N} \times \mathbf{R} \times \mathbf{R}_{++}^{H+I}$  such that  $x^h \in \mathcal{X}^h$  for all  $h$ ,  $y^i \in N(\bar{y}^i) \cap \mathcal{Y}^i$  for all  $i$ , and

$$\begin{bmatrix} (\nabla_{x^h} U^h(x^h, a^h, A^h) - \lambda^h q) \\ (F^i(y^i, b_0^i, b^i, B^i))_{i \neq 0} \\ (\nabla_{y^i} F^i(y^i, b_0^i, b^i, B^i) - \gamma^i p)_{i \neq 0} \\ F^0(y^0, b_0^0, b^0, B^0) \\ \sum_h x^h - \sum_i y^i - \sum_h e^h \\ (q^T x^h - R - \sum_{i \neq 0} \theta_i^h p^T y^i - q^T e^h) \end{bmatrix} = 0. \quad (3.6)$$

Let  $T(r)$  be the set of tax equilibria of  $\mathcal{E}(r)$ .

The first and the last set of equalities in (3.6) are the necessary conditions for utility maximization for consumers, the second and the third set of equalities are the necessary conditions for profit maximization of competitive firms, the fourth equality is the technological constraint on the public sector, while the fifth set of equalities are the economy-wide resource constraints. Note that if  $\langle (x^h), (y^i), p, q, R, (\lambda^h), (\gamma^i)_{i \neq 0} \rangle$  is a tax equilibrium,

<sup>20</sup> Where  $\Delta_{H-1} = \{\theta \in \mathbf{R}_{++}^H \mid \sum_i \theta_i = 1\}$ .

<sup>21</sup>  $\Delta_{H-1}^I$  is the Cartesian product of  $\Delta_{H-1}$  taken  $I$  times.

then so is  $\langle (x^h), (y^i), \mu p, \mu q, \mu R, (\frac{1}{\mu} \lambda^h), (\frac{1}{\mu} \gamma^i)_{i \neq 0} \rangle$ . The system permits a normalization. We adopt the normalization  $p_1 = 1$ . Denote the vector of prices of goods  $k = 2, \dots, N$  by  $\hat{p}$ . Then  $\hat{p} \in \mathbf{R}^{N-1}$ . The vector  $p \in \mathbf{R}^N$  denotes  $\langle 1, \hat{p} \rangle$ .<sup>22</sup>

An implication of the Walras law is that, at a tax equilibrium of  $\mathcal{E}(r)$ , the government's budget is balanced. To see this, multiply both sides of the second-last equation in (3.6) by  $q$  to obtain

$$q^T \sum_h x^h = (p^T + q^T - p^T) \sum_{i \neq 0} y^i + q^T y^0 + q^T \sum_h e^h. \quad (3.7)$$

Now employ the last equation in (3.6) to obtain

$$HR = (q^T - p^T) \sum_{i \neq 0} y^i + q^T y^0. \quad (3.8)$$

(3.8) is the government's budget balance condition. It implies that the total tax revenue of the government ( $[q - p] \sum_{i \neq 0} y^i$ ) plus the government receipts from sale of goods publically produced ( $qy^0$ ) must equal the total disbursements of the government to the  $H$  consumers in the form of uniform lump-sum transfers ( $HR$ ).

In this paper, we do not deal with the issue of existence of a tax equilibrium. Issues of existence of tax equilibria have been studied in other papers.<sup>23</sup> We assume that tax equilibria exist.

**Assumption E:** For all  $r \in \mathcal{R}$ , we have  $T(r) \neq \emptyset$ .

#### 4. The second-best Pareto problem and the constraint qualification (CQ).

Let  $n_c = HN + N(I+1) + 2N + H + I$ . Denote a vector  $\langle (x^h), (y^i), \hat{p}, q, R, (\lambda^h), (\gamma^i)_{i \neq 0} \rangle \in \mathbf{R}^{n_c}$  by  $c$ . Denote  $\prod_h \mathcal{X}^h \times \prod_i N_\epsilon(\bar{y}^i) \times \mathbf{R}_{++}^{2N-1} \times \mathbf{R} \times \mathbf{R}_{++}^{H+I} \subset \mathbf{R}^{n_c}$  by  $\mathcal{C}$ . Given  $r \in \mathcal{R}$  and a vector of utilities  $\langle u^2, \dots, u^H \rangle \in \mathbf{R}^{H-1}$  of consumers  $h = 2, \dots, H$ , the second-best problem of Ramsey tax economies is:

$$\begin{aligned} \mathcal{V}(u^2, \dots, u^H, r) &:= \max_{c \in \mathcal{C}} U^1(x^1, a^1, A^1) \\ &\text{subject to} \\ &c \in T(r) \text{ and} \\ &u^h = U^h(x^h, a^h, A^h) \quad \forall h = 2, \dots, H. \end{aligned} \quad (4.1)$$

Given  $r \in \mathcal{R}$ , we are interested in studying the structure of the second-best utility possibility frontier of  $\mathcal{E}(r)$ , which is defined as the set

$$U(r) := \{ \langle u^1, \dots, u^H \rangle \in \mathbf{R}^H \mid \langle u^2, \dots, u^H \rangle \in \mathbf{R}^{H-1} \text{ and } u^1 = \mathcal{V}(u^2, \dots, u^H, r) \}. \quad (4.2)$$

<sup>22</sup> In what follows, given a vector  $a = \langle a_1, \dots, a_N \rangle \in \mathbf{R}^N$ ,  $\hat{a}$  will denote the vector  $\langle a_2, \dots, a_N \rangle \in \mathbf{R}^{N-1}$ , so that  $a = \langle a_1, \hat{a} \rangle$ . In defining tax equilibria, from now on, we follow the normalization  $p_1 = 1$ . This means that, from now on, the domain of producer prices has been restricted to  $\mathbf{R}_{++}^{N-1}$ .

<sup>23</sup> See Shoven [1973], Guesnerie [1979], and Geanakoplas and Polemarchakis [2008].

The definition of  $U(r)$  suggests that for  $U(r)$  to have the expected feature of a  $H - 1$ -dimensional manifold, it is required that the value function  $\mathcal{V}(r, \cdot)$  of Problem (4.1) is well-defined in an open subset of utility profiles of consumers  $2, \dots, H$  in  $\mathbf{R}^{H-1}$  for all  $r \in \mathcal{R}$ . A necessary condition for this to hold is that the set of parameter vectors  $\langle u^2, \dots, u^H \rangle$ , for which the constraint set of Problem (4.1) is non-empty, is an open subset of  $\mathbf{R}^{H-1}$ . In this section we identify conditions that will ensure this. Define the function  $\bar{\mathbf{G}} : \mathcal{C} \times \mathcal{R} \times \mathbf{R}^{H-1} \rightarrow \mathbf{R}^{H+HN+I+IN+N+H}$  with image

$$\bar{\mathbf{G}}(c, r, u^2, \dots, u^H) = \begin{bmatrix} (U^h(x^h, a^h, A^h) - u^h) \\ (\nabla_{x^h} U^h(x^h, a^h, A^h) - \lambda^h q) \\ (F^i(y^i, b_0^i, b^i, B^i))_{i \neq 0} \\ (\nabla_{y^i} F^i(y^i, b_0^i, b^i, B^i) - \gamma^i p)_{i \neq 0} \\ F^0(y^0, b_0^0, b^0, B^0) \\ \sum_h x^h - \sum_i y^i - \sum_h e^h \\ (q^T x^h - R - \sum_{i \neq 0} \theta_i^h p^T y^i - q^T e^h) \end{bmatrix}. \quad (4.3)$$

Define also the mapping  $\bar{\mathbf{G}}_{r, u^2, \dots, u^H} : \mathcal{C} \rightarrow \mathbf{R}^{H+HN+I+IN+N+H}$  with image  $\bar{\mathbf{G}}_{r, u^2, \dots, u^H}(c) = \bar{\mathbf{G}}(c, r, u^2, \dots, u^H)$ .<sup>24</sup> It is clear that  $c \in \mathcal{C}$  is in the constraint set of Problem (4.1) for parameter values  $\langle r, u^2, \dots, u^H \rangle \in \mathcal{R} \times \mathbf{R}^{H-1}$  if and only if  $\bar{\mathbf{G}}(c, r, u^2, \dots, u^H) = 0$ .

In Subsection 5.1, we will apply the theorem of Lagrange to solve Problem (4.1). To do so requires ensuring that the constraint qualification of the problem holds, that is, for every vector of parameter values  $\langle r, u^2, \dots, u^H \rangle \in \mathcal{R} \times \mathbf{R}^{H-1}$ , the Jacobian matrix of the function  $\bar{\mathbf{G}}_{r, u^2, \dots, u^H}$  is full-row ranked whenever  $\bar{\mathbf{G}}_{r, u^2, \dots, u^H}(c) = 0$ .<sup>25</sup> In other words,  $\bar{\mathbf{G}}_{r, u^2, \dots, u^H} \pitchfork 0$  for every  $\langle r, u^2, \dots, u^H \rangle \in \mathcal{R} \times \mathbf{R}^{H-1}$ .<sup>26</sup> When this is true then, firstly, from the theorem of Lagrange, it follows that, at a solution to Problem (4.1), the gradient of the objective function can be expressed as a linear combination of the gradients of the constraints (the weights being the Lagrange multipliers) and, secondly, from the implicit function theorem, it follows that, starting from any tax equilibrium  $c$  of an economy  $\mathcal{E}(r)$  that results in utilities  $\langle u^2, \dots, u^H \rangle$  for consumers  $h = 2, \dots, H$ , any utility profile in a local neighborhood of  $\langle u^2, \dots, u^H \rangle$  can be realized as a tax equilibrium of  $\mathcal{E}(r)$  that lies in a local neighborhood of  $c$ .

A condition like Assumption CQ, below, is required to ensure that the constraint qualification holds for Problem (4.1) for *all* vectors in the parameter space.<sup>27</sup> To state

<sup>24</sup> Given any mapping  $\mathbf{f} : A \times B \rightarrow C$  with image  $\mathbf{f}(a, b) = c$ ,  $\mathbf{f}_a : B \rightarrow C$  is defined as the mapping with image  $\mathbf{f}_a(b) = \mathbf{f}(a, b)$  whenever  $a \in A$ .

<sup>25</sup> See Mas-Colell et al. [1995], pp. 956-57.

<sup>26</sup> Let  $f : A \times B \rightarrow C$  be mapping with image  $f(a, b) = c$ . Then  $f$  is transverse to zero, denoted by  $f \pitchfork 0$ , if  $f(a, b) = 0$  implies  $\nabla f(a, b)$  is full-row ranked.

<sup>27</sup> Note, in the absence of conditions like Assumption CQ, it can be shown easily by applying the transversality theorem (see the appendix for a statement of this theorem) that the constraint qualification will hold for *almost all* vectors in the parameter space  $\mathcal{R}$  except on a closed subset of  $\mathcal{R}$  of measure zero. However, in this case, we cannot rule out the possibility that the set of parameter vectors for which

Assumption CQ, we define the following perturbations: For all  $h$ , given the curvature properties of  $U^h$ , there exists a matrix  $\dot{\mathbf{X}}^h$  of perturbations in  $x^h$  and  $\lambda^h$ , which we denote by<sup>28</sup>

$$\dot{\mathbf{X}}^h = \begin{bmatrix} \dot{x}_1^{h1} & \dots & \dot{x}_1^{hN} & \dot{x}_1^{h\lambda} \\ \vdots & \vdots & \vdots & \vdots \\ \dot{x}_N^{h1} & \dots & \dot{x}_N^{hN} & \dot{x}_N^{h\lambda} \\ \dot{\lambda}_\lambda^{h1} & \dots & \dot{\lambda}_\lambda^{hN} & \dot{\lambda}_\lambda^{h\lambda} \end{bmatrix}, \quad (4.4)$$

such that<sup>29</sup>

$$\begin{bmatrix} \nabla_{x^h x^h}^2 U^h & \nabla_{x^h} U^h \\ \nabla_{x^h}^T U^h & 0 \end{bmatrix} \dot{\mathbf{X}}^h = \mathcal{I}_{N+1}. \quad (4.5)$$

Similarly, for all  $i \neq 0$ , given the curvature properties of  $F^i$ , there exists a matrix  $\dot{\mathbf{Y}}^i$  of perturbations in  $y^i$  and  $\gamma^i$ , which we denote by

$$\dot{\mathbf{Y}}^i = \begin{bmatrix} \dot{y}_1^{i1} & \dots & \dot{y}_1^{iN} & \dot{y}_1^{i\gamma} \\ \vdots & \vdots & \vdots & \vdots \\ \dot{y}_N^{i1} & \dots & \dot{y}_N^{iN} & \dot{y}_N^{i\gamma} \\ \dot{\gamma}_\lambda^{i1} & \dots & \dot{\gamma}_\lambda^{iN} & \dot{\gamma}_\lambda^{i\gamma} \end{bmatrix}, \quad (4.6)$$

such that

$$\begin{bmatrix} \nabla_{y^i y^i}^2 F^i & \nabla_{y^i} F^i \\ \nabla_{y^i}^T F^i & 0 \end{bmatrix} \dot{\mathbf{Y}}^i = \mathcal{I}_{N+1}. \quad (4.7)$$

---

the constraint set is non-empty lies in this latter closed subset of measure zero, where the constraint qualification fails. By ensuring that the constraint qualification holds for *all* vectors in  $\mathcal{R}$ , Assumption CQ rules out such a case.

<sup>28</sup>  $U^h$  is strictly concave and hence strictly quasi-concave. Hence, the determinant of its bordered Hessian is non-zero.

<sup>29</sup>  $\mathcal{I}_{N+1}$  denotes the identity matrix of dimension  $N + 1$ .

**Assumption CQ:** For all  $r \in \mathcal{R}$  and all  $c \in T(r)$ , we have

$$\left[ \nabla_{y_1^0} F^0 \quad \nabla_{y_2^0} F^0 \quad \dots \quad \nabla_{y_N^0} F^0 \right] \begin{bmatrix} \dot{x}_1^{11} & \dots & \dot{x}_1^{1N} \\ \vdots & \vdots & \vdots \\ \dot{x}_N^{11} & \dots & \dot{x}_N^{1N} \end{bmatrix} \begin{bmatrix} \frac{\nabla_{x_1^1, x_1^1}^2 U^1}{\nabla_{y_1^0} F^0} \\ \frac{\nabla_{x_1^1, x_2^1}^2 U^1}{\nabla_{y_1^0} F^0} \\ \vdots \\ \frac{\nabla_{x_1^1, x_N^1}^2 U^1}{\nabla_{y_1^0} F^0} \end{bmatrix} \neq 1 \quad (4.8)$$

and

$$\begin{bmatrix} x_1^2 - e_1^2 & \dots & x_N^2 - e_N^2 \\ \vdots & \vdots & \vdots \\ x_1^H - e_1^H & \dots & x_N^H - e_N^H \end{bmatrix} \text{ is full-row ranked.}$$

The matrix in the second condition in (4.8) is the matrix of net demands of consumers  $2, \dots, H$  at any tax equilibrium. Assumption CQ requires this matrix to be full-row ranked. A necessary condition for this is that  $H - 1 \leq N$ . Intuitively, this is because  $N$  is the number of instruments the government has available in the form of commodity taxes and to be able to realize any direction of change in the utilities of  $H - 1$  consumers, there is a need for at least  $H - 1$  instruments. From Roy's theorem, the matrix of net demands of the  $H - 1$  consumers is also the matrix of the derivatives of the indirect utility functions of these consumers with respect to consumer prices (or taxes). When this has full-row rank, then it is possible to change the indirect utilities of consumers  $2, \dots, H$  independently of one another by changing commodity tax rates. If, in addition, the first condition in (4.8) also holds, then it becomes possible to realize any direction of changes in the utilities of consumers  $2, \dots, H$ , starting from an initial tax equilibrium, as a tax equilibrium in its local neighborhood. Intuitively, this condition provides a relation between the preferences of consumer one and the technology of the public sector that will ensure that the supply from the public sector and the demand vector of consumer one will adjust to accommodate the changes in the demands of consumers  $2, \dots, H$  associated with the changes in their utility.<sup>30</sup>

**Lemma CQ:** Under Assumption CQ, we have  $\bar{\mathbf{G}}_{r, u^2, \dots, u^H} \pitchfork 0$  for all  $\langle r, u^2, \dots, u^H \rangle \in \mathcal{R} \times \mathbf{R}^{H-1}$ .<sup>31</sup>

<sup>30</sup> Note that Assumption CQ will hold if utility function of consumer one is quasi linear and that all our results can be extended to strictly quasi-concave utility functions.

<sup>31</sup> It follows immediately that  $\bar{\mathbf{G}}_{r, u^2, \dots, u^H}^{-1}(0)$  is a manifold of dimension  $2N - 1$  for all  $\langle r, u^2, \dots, u^H \rangle \in \mathcal{R} \times \mathbf{R}^{H-1}$ .

Though Lemma CQ demonstrates that the constraint qualification of Problem (4.1) will hold for *every* vector of parameter values in  $\mathcal{R} \times \mathbf{R}^{H-1}$ , it is possible that the constraint set is empty for some parameter values.<sup>32</sup> Define the set

$$\mathcal{P} = \{ \langle r, u^2, \dots, u^H \rangle \in \mathcal{R} \times \mathbf{R}^{H-1} \mid \exists c = \langle (x^h), (y^i), \hat{p}, q, R, (\lambda^h), (\gamma^i)_{i \neq 0} \rangle \in T(r) \text{ such that } u^h = U^h(x^h, a^h, A^h) \forall h = 2, \dots, H \}. \quad (4.9)$$

This is the set of parameter values of Problem (4.1) for which the constraint set of Problem (4.1) is non-empty. For all  $r \in \mathcal{R}$  define also the set

$$\mathcal{P}(r) = \{ \langle u^2, \dots, u^H \rangle \in \mathbf{R}^{H-1} \mid \langle r, u^2, \dots, u^H \rangle \in \mathcal{P} \}. \quad (4.10)$$

This is the set of utility profiles of consumers  $h = 2, \dots, H$  that can be realized as tax equilibria of economy  $\mathcal{E}(r)$ .

**Remark CQ.** Assumption E implies that  $\mathcal{P}(r)$  is not an empty set for all  $r \in \mathcal{R}$ . Hence,  $\mathcal{P}$  is not an empty set.

The following theorem and its corollary demonstrate that for all  $r \in \mathcal{R}$ , the set  $\mathcal{P}(r)$ , which is the set of parameter values  $u^2, \dots, u^H$  where the constraint set of Problem (4.1) is well defined, is an open subset of  $\mathbf{R}^{H-1}$ .

**Theorem CQ:** *If Assumption CQ holds then  $\mathcal{P}$  is open relative to  $\mathcal{R} \times \mathbf{R}^{H-1}$ .*

**Corollary CQ:** *If Assumption CQ holds then, for every  $r \in \mathcal{R}$ ,  $\mathcal{P}(r)$  is an open subset of  $\mathbf{R}^{H-1}$ .*

## 5. The generic structure of the second-best (SB) utility possibility frontier and the characterization of production and consumption efficiencies.

In all the remaining analysis we will restrict the set of parameter vectors of Problem (4.1) to  $\mathcal{P}$ . We will assume that  $N \geq 1$ ,  $H \geq 1$ ,  $N \geq H - 1$  and that Assumptions E and CQ hold. In that case, as demonstrated by Lemma CQ, the constraint qualification of Problem (4.1) holds and the theorem of Lagrange can be applied to obtain the necessary conditions that characterize the solution of Problem (4.1).

In this section we (i) identify conditions under which the value function  $\mathcal{V}(r, \cdot)$  of Problem (4.1) is continuous on the domain  $\mathcal{P}(r)$  for all  $r \in \mathcal{R}$  and, hence,  $U(r)$  is a  $H - 1$ -dimensional manifold, (ii) use the first order conditions of Problem (4.1) to characterize second-best production and consumption efficiencies in terms of the Lagrange multipliers of the problem, and (iii) show that the set of Lagrange multipliers and choice variables that solve Problem (4.1) for all parameter vectors in  $\mathcal{P}$  lies in a compact set.

<sup>32</sup> For any given economy  $\mathcal{E}(r)$ , the set of feasible states  $\mathcal{S}(r)$  and hence the set of feasible utility profiles of consumers  $h \neq 1$  are bounded. So for utility profiles associated with (infeasible) states not in  $\mathcal{S}(r)$ , the constraint set of Problem (4.1) is empty.



In the next sections, (iii) is used to show that the results regarding the various components of the second-best Pareto manifold hold in open and dense subsets of our class of economies  $\mathcal{E}$  and (i) and (ii) are used for establishing the generic size and structure of the various components of the second-best Pareto manifold.

The Lagrangian of Problem (4.1) is

$$\begin{aligned}
L = & U^1(x^1, a^1, A^1) - \sum_{h \neq 1} \alpha^h [u^h - U^h(x^h, a^h, A^h)] - \sum_h \psi^h [q^T x^h - R - \sum_i \theta_i^h p^T y^i - q^T e^h] \\
& - \sum_{h,k} \kappa_k^h \left[ \frac{\partial U^h}{\partial x_k^h} - \lambda^h q_k \right] - \sum_{i \neq 0} \mu^i F^i(y^i, b_0^i, b^i, B^i) - \sum_{i \neq 0, k} \phi_k^i \left[ \frac{\partial F^i}{\partial y^i} - \gamma^i p_k \right] - \delta F^0(y^0, b_0^0, b^0, B^0) \\
& - \sum_k \beta_k \left[ \sum_h x_k^h - \sum_i y_k^i - \sum_h e_k^h \right].
\end{aligned} \tag{5.1}$$

In the above, the Lagrangian multipliers  $(\alpha^h)_{h \neq 1}$ ,  $(\psi^h)$ ,  $(\kappa^h)$ ,  $(\mu^i)_{i \neq 0}$ ,  $(\phi^i)_{i \neq 0}$ ,  $\delta$ , and  $\beta$  are defined in an obvious manner.<sup>33</sup>

Define the vector-valued mapping  $\mathbf{\Gamma} : \mathcal{R} \times \mathbf{R}^{H-1} \times \mathcal{C} \times \mathbf{R}^{n_l} \rightarrow \mathbf{R}^{n_e}$ , with image  $\mathbf{\Gamma}((u^h)_{h \neq 1}, r, c, l)$  as follows:

$$\mathbf{\Gamma}_{\mathbf{x}}^h((u^h)_{h \neq 1}, r, c, l) = \begin{bmatrix} \nabla_{x^h} U^h(x^h, a^h, A^h) - \lambda^h q \\ \alpha^h \lambda^h q - \psi^h q - \nabla_{x^h, x^h} U^h \kappa^h - \beta \end{bmatrix} \quad \forall h, \quad (2HN) \tag{5.2}$$

$$\mathbf{\Gamma}_{\mathbf{y}}^i((u^h)_{h \neq 1}, r, c, l) = \begin{bmatrix} F^i(y^i, b_0^i, b^i, B^i) \\ \nabla_{y^i} F^i(y^i, b_0^i, b^i, B^i) - \gamma^i p \\ \sum_h \psi^h \theta_i^h p - \mu^i \gamma^i p - \nabla_{y^i, y^i} F^i \phi^i + \beta \end{bmatrix} \quad \forall i \neq 0, \quad (2IN + I) \tag{5.3}$$

$$\mathbf{\Gamma}_{\mathbf{y}}^0((u^h)_{h \neq 1}, r, c, l) = \begin{bmatrix} F^0(y^0, b_0^0, b^0, B^0) \\ -\delta \nabla_{y^0} F^0 + \beta \end{bmatrix}, \quad (N + 1) \tag{5.4}$$

$$\mathbf{\Gamma}_{\beta}((u^h)_{h \neq 1}, r, c, l) = \left[ \sum_h x^h - \sum_i y^i - \sum_h e^h \right], \quad (N) \tag{5.5}$$

$$\mathbf{\Gamma}_{\mathbf{p}, \gamma}((u^h)_{h \neq 1}, r, c, l) = \begin{bmatrix} (\phi^{iT} p)_{i \neq 0} \\ \sum_h \psi^h \sum_i \theta_i^h \hat{y}^i + \sum_i \hat{\phi}^i \gamma^i \end{bmatrix}, \quad ((N - 1) + I) \tag{5.6}$$

$$\mathbf{\Gamma}_{\mathbf{q}, \lambda, \psi}((u^h)_{h \neq 1}, r, c, l) = \begin{bmatrix} (q^T x^h - R - \sum_i \theta_i^h p^T y^i - q^T e^h) \\ -\sum_h \psi^h [x^h - e^h] + \sum_h \kappa^h \lambda^h \\ (\kappa^{hT} q)_h \end{bmatrix}, \quad (N + 2H) \tag{5.7}$$

$$\mathbf{\Gamma}_{\mathbf{R}}((u^h)_{h \neq 1}, r, c, l) = \sum_h \psi^h, \quad \text{and} \quad (1) \tag{5.8}$$

$$\mathbf{\Gamma}_{\mathbf{u}}((u^h)_{h \neq 1}, r, c, l) = (u^h - U^h(x^h, a^h, A^h)). \quad (H - 1) \tag{5.9}$$

<sup>33</sup> We define  $\beta = \langle \beta_1, \dots, \beta_N \rangle$ . For all  $h$ ,  $\kappa^h = \langle \kappa_1^h, \dots, \kappa_N^h \rangle$ . For all  $i \neq 0$ ,  $\phi^i = \langle \phi_1^i, \dots, \phi_N^i \rangle$ .

Then, the first-order conditions of Problem (4.1) are  $\mathbf{\Gamma}((u^h)_{h \neq 1}, r, c, l) = 0$ . Let  $2HN + 2IN + 4N + 3H + 2I = n_e$ . This is the number of equations in  $\mathbf{\Gamma}((u^h)_{h \neq 1}, r, c, l) = 0$ . Let  $HN + IN + 2H + N + I$  be denoted by  $n_l$ . The vector of Lagrange multipliers, denoted by  $l = \langle (\alpha^h)_{h \neq 1}, (\psi^h), (\kappa^h), (\phi^i)_{i \neq 0}, (\mu^i)_{i \neq 0}, \delta \rangle$ , lies in  $\mathbf{R}^{n_l}$ . We note that  $n_e = n_l + n_c$ .

### 5.1. The generic structure of the second-best utility possibility frontier.

For every  $r \in \mathcal{R}$ , let the choice variables and Lagrange multipliers that solve the first-order conditions  $\mathbf{\Gamma}_r((u^h)_{h \neq 1}, c, l) = 0$  (that is, let the stationary values of Problem (4.1)) be given by the map  $\Phi_r : \mathcal{P}(r) \rightarrow \mathbf{R}^{n_e}$  with image  $\Phi_r(u^2, \dots, u^H) = \mathbf{\Gamma}_{r, u^2, \dots, u^H}^{-1}(0)$ . Let the choice variables and Lagrange multipliers that actually solve Problem (4.1) be given by the map  $\Phi_r^* : \mathcal{P}(r) \rightarrow \mathbf{R}^{n_e}$  with image  $\Phi_r^*(u^2, \dots, u^H)$ . Clearly,  $\Phi_r^*(u^2, \dots, u^H) \subseteq \Phi_r(u^2, \dots, u^H)$  for all  $\langle u^2, \dots, u^H \rangle \in \mathcal{P}(r)$ .

For every  $r \in \mathcal{R}$ , Assumption SB1, below, assumes that  $\Phi_r$  is non-empty, locally unique, and continuous, with the cardinality of the set  $\Phi_r(u^2, \dots, u^H)$  being finite and constant (say  $J$ ) for all  $\langle u^2, \dots, u^H \rangle \in \mathcal{P}(r)$ . This is not a restrictive assumption because, in the later sections, when we partition the set  $\mathbf{\Gamma}_r^{-1}(0)$  into (1) the joint production and consumption inefficient, (2) production efficient but consumption inefficient, (3) production inefficient but consumption efficient, and (4) joint production and consumption efficient components, we find that, generically, local uniqueness and continuity hold for the mapping  $\Phi_r$  in each of these components.

**Assumption SB1.** For all  $r \in \mathcal{R}$ ,

- (a) the mapping  $\Phi_r$  is non-empty valued and
- (b) there exist
  - (i) a positive integer  $J$  and
  - (ii) for every  $\langle \bar{u}^2, \dots, \bar{u}^H \rangle \in \mathcal{P}(r)$ , a neighborhood  $V_{\bar{u}^2, \dots, \bar{u}^H}(r)$  around  $\langle \bar{u}^2, \dots, \bar{u}^H \rangle$  that is open in  $\mathcal{P}(r)$ , pair-wise disjoint neighborhoods  $O_{\bar{u}^2, \dots, \bar{u}^H}^j(r)$  open in  $\mathbf{R}^{n_e}$  and continuous functions  $\mathbf{g}_{\mathbf{r}, \bar{\mathbf{u}}^2, \dots, \bar{\mathbf{u}}^H}^j : V_{\bar{u}^2, \dots, \bar{u}^H}(r) \rightarrow O_{\bar{u}^2, \dots, \bar{u}^H}^j(r)$  for  $j \in \{1, \dots, J\} =: J$  such that, for all  $\langle u^2, \dots, u^H \rangle \in V_{\bar{u}^2, \dots, \bar{u}^H}(r)$ , we have

$$\Phi_r(u^2, \dots, u^H) = \left\{ \mathbf{g}_{\mathbf{r}, \bar{\mathbf{u}}^2, \dots, \bar{\mathbf{u}}^H}^j(u^2, \dots, u^H) \right\}_{j \in J}. \quad (5.10)$$

**Remark SB.** If Assumption SB1 holds, then for all  $r \in \mathcal{R}$ , the mapping  $\Phi_r^*$  is nonempty valued.<sup>34</sup>

If Assumption SB1 holds, then for all  $r \in \mathcal{R}$  and for every  $\langle \bar{u}^2, \dots, \bar{u}^H \rangle \in \mathcal{P}(r)$ , we define the set

$$J_{\bar{u}^2, \dots, \bar{u}^H}^*(r) = \left\{ j \in J \mid \mathbf{g}_{\mathbf{r}, \bar{\mathbf{u}}^2, \dots, \bar{\mathbf{u}}^H}^j(\bar{u}^2, \dots, \bar{u}^H) \in \Phi_r^*(\bar{u}^2, \dots, \bar{u}^H) \right\}. \quad (5.11)$$

<sup>34</sup> This because the cardinality of the set  $\Phi_r(u^2, \dots, u^H)$  is assumed to be finite and constant ( $J$ ) for all  $\langle u^2, \dots, u^H \rangle \in \mathcal{P}(r)$ .

Thus,  $J_{\bar{u}^2, \dots, \bar{u}^H}^*(r)$  is the cardinality of  $\overset{*}{\Phi}_r(\bar{u}^2, \dots, \bar{u}^H)$ . Remark SB implies that  $J_{\bar{u}^2, \dots, \bar{u}^H}^*(r)$  is non-empty for every  $\langle \bar{u}^2, \dots, \bar{u}^H \rangle \in \mathcal{P}(r)$ .

Assumption SB1 and Remark SB imply that the mapping  $\overset{*}{\Phi}_r$  is locally unique. However, because of the non-convexity problem that we discussed in our examples in Section 2,  $\overset{*}{\Phi}_r$  need not be continuous, in general. Assumption SB2, which will be invoked in the later sections, assumes that it is locally continuous.

**Assumption SB2.** For all  $r \in \mathcal{R}$  and for every  $\langle \bar{u}^2, \dots, \bar{u}^H \rangle \in \mathcal{P}(r)$  there exists a neighborhood around  $\langle \bar{u}^2, \dots, \bar{u}^H \rangle$  that is open in  $\mathcal{P}(r)$  such that  $\overset{*}{\Phi}_r$  restricted to this neighborhood is a continuous correspondence.

For all  $r \in \mathcal{R}$ , define the set

$$\Gamma(r) = \{ \langle u^2, \dots, u^H, c, l \rangle \in \mathbf{R}^{H-1} \times \mathcal{C} \times \mathbf{R}^{n_l} \mid \mathbf{\Gamma}(r, u^2, \dots, u^H, c, l) = 0 \} \quad (5.12)$$

This is the graph of the mapping  $\overset{*}{\Phi}_r$ .

Theorem SB establishes the size and the topological structure of the utility possibility frontier of private-ownership economies with Ramsey taxation. It shows that, if the mapping  $\overset{*}{\Phi}_r$  of stationary values of the second-best Problem (4.1) is locally unique and continuous, then  $U(r)$  is a  $H - 1$ -dimensional manifold for all  $r \in \mathcal{R}$ . Note that local continuity of the solution mapping  $\overset{*}{\Phi}_r$  of Problem (4.1) is not required for this result. In a local neighborhood of any point  $\langle \bar{u}^2, \dots, \bar{u}^H \rangle \in \mathcal{P}(r)$ , the solution to Problem (4.1) can switch discontinuously between the functions  $\mathbf{g}_{\mathbf{r}, \bar{\mathbf{u}}^2, \dots, \bar{\mathbf{u}}^H}^j$  for  $j \in J$ .<sup>35</sup>

If, in addition to being locally unique, the solution mapping of Problem (4.1) is also locally continuous, that is, Assumption SB2 is also true, then, around a local neighborhood of  $\bar{u}^2, \dots, \bar{u}^H \in \mathcal{P}(r)$ , such a switching of the solution is not possible.<sup>36</sup> The solution mapping in this neighborhood of  $\langle \bar{u}^2, \dots, \bar{u}^H \rangle$  is a union over  $j \in J_{\bar{u}^2, \dots, \bar{u}^H}^*(r)$  of the values taken by the maps  $\mathbf{g}_{\mathbf{r}, \bar{\mathbf{u}}^2, \dots, \bar{\mathbf{u}}^H}^j$ . Moreover, for any  $j \in J_{\bar{u}^2, \dots, \bar{u}^H}^*(r)$ , a homeomorphism can be established between the graph of  $\mathbf{g}_{\mathbf{r}, \bar{\mathbf{u}}^2, \dots, \bar{\mathbf{u}}^H}^j$  and an open set of  $U(r)$ .<sup>37</sup> We will exploit this homeomorphism later to obtain the structure of the different components of  $U(r)$ .

**Theorem SB:** *Let Assumption SB1 hold.*

(i) *The sets  $\Gamma(r)$  and  $U(r)$  are  $H - 1$  dimensional manifolds for all  $r \in \mathcal{R}$ .*

(ii) *If, in addition, Assumption SB2 holds, then for every  $\langle \bar{u}^2, \dots, \bar{u}^H \rangle \in \mathcal{P}(r)$  there exists a neighborhood  $\hat{V}_{\bar{u}^2, \dots, \bar{u}^H}(r)$  open in  $\mathcal{P}(r)$  around  $\langle \bar{u}^2, \dots, \bar{u}^H \rangle$  such that, for all  $\langle u^2, \dots, u^H \rangle \in \hat{V}_{\bar{u}^2, \dots, \bar{u}^H}(r)$ , we have*

$$\overset{*}{\Phi}_r(u^2, \dots, u^H) = \{ \mathbf{g}_{\mathbf{r}, \bar{\mathbf{u}}^2, \dots, \bar{\mathbf{u}}^H}^j(u^2, \dots, u^H) \}_{j \in J_{\bar{u}^2, \dots, \bar{u}^H}^*(r)} \quad (5.13)$$

<sup>35</sup> In Figure 3, for example, the solution switches from the curve AB to curve CD when utility of consumer two changes from  $\hat{u}^2$  to  $\bar{u}^2$ .

<sup>36</sup> For example, as in Figure 1.

<sup>37</sup> For example, as was shown in Figure 4.

and, for every  $j \in J_{\bar{u}^2, \dots, \bar{u}^H}^*(r)$ , there exists a homeomorphism  $\zeta^j$  between the graph of  $\mathbf{g}_{r, \bar{u}^2, \dots, \bar{u}^H}^j$  restricted to  $\hat{V}_{\bar{u}^2, \dots, \bar{u}^H}(r)$  and an open subset of  $U(r)$ .

## 5.2. Characterizing production and consumption efficiency.

Note that, from the Lagrangian (5.1) of Problem (4.1), it is clear that the social shadow prices of the resources are indicated by the value of the vector  $\beta$  at a solution to Problem (4.1). This is because this is the vector of the Lagrange multipliers associated with the resource constraints. We can now define production and consumption efficient stationary values of Problem (4.1) as well as second-best production and consumption efficiency.

**Definition.** Let  $\langle r, u^2, \dots, u^H \rangle \in \mathcal{P}$  and  $\langle c, l \rangle = \langle (x^h), (y^i), \hat{p}, q, R, (\lambda^h), (\gamma^i) \rangle \in \Phi_r(u^2, \dots, u^H)$ .  $c$  is a production (consumption) efficient stationary value of Problem (4.1) if there exists  $\mu > 0$  such that  $p = \mu\beta$  ( $q = \mu\beta$ ). If  $c$  is a production (consumption) efficient stationary value of Problem (4.1) then  $c$  is a production (consumption) efficient second-best equilibrium if  $c \in \hat{\Phi}_r^*(u^2, \dots, u^H)$ .

Note that the first-order condition  $\mathbf{\Gamma}_y^0(r, c, l, u^2, \dots, u^H) = 0$  (see (5.4)) of Problem (4.1) implies that, at a stationary value of the problem,  $\beta$  is proportional to the shadow prices in the public sector ( $\nabla_{y^0} F^0$ ). Hence production (consumption) efficiency at a stationary value of Problem (4.1) implies the proportionality of the private sector producer (consumer) prices and the shadow prices in the public sector. Lemmas SB1 to SB3 characterize production and consumption efficient stationary values of Problem (4.1) in terms of the Lagrange multipliers of the problem.

Lemma SB1 relates production efficiency to the multipliers  $(\phi^i)_{i \neq 0}$ , Lemma SB2 relates consumption efficiency to the multipliers  $(\kappa^h)$ , and Lemma SB3 relates the first-best equilibria to the multipliers  $(\psi^h)$ .

**Lemma SB1:** Let  $\langle r, u^2, \dots, u^H \rangle \in \mathcal{P}$  and  $\langle c, l \rangle = \langle (x^h), (y^i), \hat{p}, q, R, (\lambda^h), (\gamma^i) \rangle \in \Phi_r(u^2, \dots, u^H)$ .

1.  $c$  is a production efficient stationary value of Problem (4.1) if and only if  $\hat{p} - \frac{\hat{\beta}}{\beta_1} = 0$ .
2.  $c$  is a production efficient stationary value of Problem (4.1) if and only if  $(\phi^i)_{i \neq 0} = 0$ .
3. If  $c$  is a production inefficient stationary value of Problem (4.1) then, for every  $i \neq 0$ ,  $\phi^i \neq 0$ .

**Lemma SB2:** Let  $\langle r, u^2, \dots, u^H \rangle \in \mathcal{P}$  and  $\langle c, l \rangle = \langle (x^h), (y^i), \hat{p}, q, R, (\lambda^h), (\gamma^i) \rangle \in \Phi_r(u^2, \dots, u^H)$ .

1.  $c$  is a consumption efficient stationary value of Problem (4.1) if and only if  $\frac{\hat{q}}{q_1} - \frac{\hat{\beta}}{\beta_1} = 0$  for all  $h$ .
2.  $c$  is a consumption efficient stationary value of Problem (4.1) if and only if  $(\kappa^h) = 0$ .
3. If  $c$  is a consumption inefficient stationary value of Problem (4.1) then, for every  $h$ ,  $\kappa^h \neq 0$ .

**Lemma SB3:** Let  $\langle r, u^2, \dots, u^H \rangle \in \mathcal{P}$  and  $\langle c, l \rangle = \langle (x^h), (y^i), \hat{p}, q, R, (\lambda^h), (\gamma^i) \rangle \in \Phi_r(u^2, \dots, u^H)$ .  $c$  is a joint consumption and production efficient stationary value of Problem (4.1) if and only if  $(\psi^h) = 0$  for all  $h$ .

To interpret these results, note that the current tax regime can be interpreted as a special case of more general regimes where the government can implement firm-specific changes in private producer prices  $(p^i)_{i \neq 0}$ , consumer-specific changes in consumer prices  $(q^h)$ , consumer-specific (personalized) changes in lump-sum transfers  $(R^h)$ , or firm-specific profit taxes  $(\tau^i)_{i \neq 0}$ . This is because a tax equilibrium in the current regime can be interpreted to be an equilibrium in these more general regimes where, for all  $i \neq 0$  and  $h$ ,  $p^i = 0$ ,  $q^h = 0$ ,  $R^h = 0$ , and  $\tau^i = 0$ . These additional policy instruments can be taken as parameters of Problem (4.1), so that the value function of this problem is  $\mathcal{V}(u^2, \dots, u^H, r, (p^i)_{i \neq 0}, (q^h), (R^h), (\tau^i)_{i \neq 0})$ , and it is evaluated at a point where all these additional parameters take the value zero.<sup>38</sup> In that case the Lagrangian of Problem (4.1) is

$$\begin{aligned}
L = & U^1(x^1, a^1, A^1) - \sum_{h \neq 1} \alpha^h [u^h - U^h(x^h, a^h, A^h)] - \sum_{h,k} \kappa_k^h \left[ \frac{\partial U^h}{\partial x_k^h} - \lambda^h (q_k + q_k^h) \right] \\
& - \sum_h \psi^h [q^T x^h - R - \sum_i \theta_i^h (p^T y^i - \tau^i) - q^T e^h - R^h] \\
& - \sum_{i \neq 0} \mu^i F^i(y^i, b_0^i, b^i, B^i) - \sum_{i \neq 0, k} \phi_k^i \left[ \frac{\partial F^i}{\partial y^i} - \gamma^i (p_k - p_k^i) \right] \\
& - \delta F^0(y^0, b_0^0, b^0, B^0) - \sum_k \beta_k \left[ \sum_h x_k^h - \sum_i y_k^i - \sum_h e_k^h \right].
\end{aligned} \tag{5.14}$$

<sup>38</sup> More precisely, note that  $(p^i)_{i \neq 0}$  does not enter the budget equations of the consumers. The new regime is one where private firms respond competitively to firm specific prices,  $p^i + p$ , and maximize profits, but the profit incomes that go to consumers are computed using  $p$ . The indirect tax revenue to the government is  $\sum_{i \neq 0} (q - p - p^i) y^i$  (the additional indirect tax revenue due to switching to the new regime is  $-\sum_{i \neq 0} p y^i$ ). Equivalently, the new regime can be shown to be one where each consumer  $h$  receives profit incomes  $\sum_{i \neq 0} \theta_i^h (p + p^i) y^i$  and  $-\sum_{i \neq 0} p^i y^i$  is also distributed back to each consumer  $h$  as a transfer  $-\sum_{i \neq 0} \theta_i^h p^i y^i$ , in addition to  $R$ , by the government. Consumer  $h$ 's income is, thus,  $R - \sum_i \theta_i^h p^T y^i - q^T e^h$  as before. Similarly, we can also make precise the regime with consumer-specific prices.

Applying the envelope theorem, it is clear that, for all  $h$  and  $i \neq 0$ , the derivatives of  $\mathcal{V}$  with respect to  $p^i$ ,  $q^h$ ,  $R^h$ , and  $\tau^i$  are  $\gamma^i \phi^i$ ,  $\lambda^h \kappa^h$ ,  $\psi^h$ , and  $\sum_h \psi^h \theta_i^h$ , respectively. These derivatives are thus the shadow prices of introducing firm-specific prices, consumer specific prices, personalized lump-sum transfers, or firm-specific profit taxes, starting from a situation where the values of these instruments were set at zero.

It is now clear that second-best production efficiency in the current regime (from Lemma SB1, this is equivalent to  $\phi^i = 0$  for all  $i \neq 0$ ) implies that there are no welfare gains in moving to a more general regime with firm-specific prices, or equivalently, a production-efficient second best in the current regime is also a second-best in the regime with firm-specific prices. Similarly, we can interpret second-best consumption efficiency (from Lemma SB2, this is equivalent to  $\kappa^h = 0$  for all  $h$ ) in the current regime.

Joint production and consumption-efficiency at a second best in the current regime, (from Lemma SB3, this is equivalent to  $\psi^h = 0$  for all  $h$ ) implies that there are no welfare gains from introducing personalized lump-sum transfers or, in other words, we are also at a first-best.

It is easy to show that if there is zero welfare gain from introducing firm-specific profit taxes at a second-best of the current regime, that is, if  $\sum_h \psi^h \theta_i^h = 0$  for all  $i \neq 0$ , then this also implies that  $\phi^i = 0$  for all  $i \neq 0$ , that is, the second-best of the current regime is also production efficient and is also a second-best of a regime with firm-specific profit taxes.<sup>39</sup> Note, however, that second-best production efficiency in the current regime is a more general phenomenon. It can happen even when there are welfare gains in introducing firm-specific profit taxation, that is, at such a point,  $\phi^i = 0$  for all  $i \neq 0$  but there can exist  $i \neq 0$  such that  $\sum_h \psi^h \theta_i^h \neq 0$ . This fact will be employed later in studying the generic structure of the production efficient subset of the the second-best manifold.

### 5.3. Boundedness of the stationary values and Lagrange multipliers of the second-best problem.

The following lemma proves that the set of stationary values and Lagrange multipliers that solve the above first-order conditions of Problem (4.1) lies in a compact set.

**Lemma SB4:** *The sets  $\mathbf{S} := \{\langle c, l \rangle \in \mathcal{C} \times \mathbf{R}^{n_l} \mid \exists \langle r, u^2, \dots, u^H \rangle \in \mathcal{P} \text{ such that } \langle c, l \rangle \in \Gamma_{r, u^2, \dots, u^H}^{-1}(0)\}$  and  $\mathbf{S}' := \{\langle c, l, u^2, \dots, u^H \rangle \in \mathcal{C} \times \mathbf{R}^{n_l} \times \mathbf{R}^{H-1} \mid \exists r \in \mathcal{R} \text{ such that } \langle c, l, u^2, \dots, u^H \rangle \in \Gamma_r^{-1}(0)\}$  lie in compact sets.*

## 6. The generic size and structure of the second-best production and consumption inefficient (SBPCI) subset of the second-best frontier.

For all  $i \neq 0$  and  $h$ , Lemmas SB1 and SB2 imply that, at a SBPCI tax equilibrium, none of the vectors of Lagrange multipliers  $\phi^i$  and  $\kappa^h$  are zero. Denote the space of all Lagrange multipliers such that  $(\phi^i)_{i \neq 0}$  and  $(\kappa^h)$  are each not zero by  $\mathbf{R}_{\phi, \kappa}^{n_l}$ .<sup>40</sup> Define the

<sup>39</sup> It has long been known that production efficiency is desirable in a regime with firm-specific profit taxation. See, *e.g.*, Dasgupta and Stiglitz [1972] and BM.

<sup>40</sup> That is,  $\mathbf{R}_{\phi, \kappa}^{n_l} = \{l \in \mathbf{R}^{n_l} \mid \forall i \neq 0, \phi^i \neq 0 \text{ and } \forall h, \kappa^h \neq 0\}$ .

mapping  $\tilde{\Gamma}$  as the restriction of the mapping  $\Gamma$  to the open set  $\mathcal{P} \times \mathcal{C} \times \mathbf{R}_{\phi, \kappa}^{n_l}$ . For every  $r \in \mathcal{R}$  define the following subset of  $U(r)$ :

$$\tilde{U}(r) = \{\langle u^1, \dots, u^H \rangle \in U(r) \mid \exists \langle c, l \rangle \in \mathcal{C} \times \mathbf{R}_{\phi, \kappa}^{n_l} \text{ such that } \tilde{\Gamma}(c, l, r, u^2, \dots, u^H) = 0\}. \quad (6.1)$$

This is the subset of  $U(r)$  which is associated with both consumption and production inefficiencies, that is, these are utility profiles corresponding to second-best tax equilibria, where the social shadow prices are not reflected by any of the observable market prices. In this section we study the generic size and structure of this component of the second-best Pareto frontier.

**Lemma SBPCI:**  $\tilde{\Gamma} \pitchfork 0$ .

**Remark SBPCI** The transversality theorem and Lemmas SB4 and SBPCI imply that  $\tilde{\Gamma}_r \pitchfork 0$  for almost all  $r \in \mathcal{R}$  except on a closed subset of  $\mathcal{R}$  of measure zero.<sup>41</sup> Further, if  $\tilde{\Gamma}_r \pitchfork 0$  then  $\tilde{\Gamma}_r^{-1}(0)$ , if not empty, is a smooth manifold of dimension  $H - 1$ .<sup>42</sup> Define  $\tilde{\mathcal{R}} = \{r \in \mathcal{R} \mid \tilde{\Gamma}_r \pitchfork 0\}$ .  $\tilde{\mathcal{R}}$  is open and dense in  $\mathcal{R}$ .<sup>43</sup>

The following theorem establishes the generic size and structure of the SBPCI component of second-best Pareto frontier in the utility space. The idea is simple. In Theorem SB, using the assumption of local continuity of the solution mapping  $\tilde{\Phi}_r^*$ , a homeomorphism  $\zeta$  was constructed between the graph of  $\tilde{\Phi}_r^*$  and the second-best Pareto frontier in the utility space  $U(r)$ . Remark SBPCI can also be used to show that the production and consumption inefficient component of the graph of  $\tilde{\Phi}_r^*$  for  $r \in \tilde{\mathcal{R}}$  is an open subset (a  $H - 1$ -dimensional submanifold) of this graph. Hence,  $\zeta$  maps this open subset of the graph of  $\tilde{\Phi}_r^*$  into a  $H - 1$ -dimensional submanifold of the second-best Pareto frontier  $U(r)$  in the utility space.

**Theorem SBPCI1:** *Let Assumptions SB1 and SB2 hold. For all  $r \in \tilde{\mathcal{R}}$ ,  $\tilde{U}(r)$ , if not empty, is a  $H - 1$ -dimensional submanifold of  $U(r)$ .*

Lemma SBPCI also indicates the generic local uniqueness of the solution to the equation system  $\tilde{\Gamma}(r, u^2, \dots, u^H, c, l) = 0$ . Noting that there are  $n_e$  equations in  $n_e$  unknowns (the endogeneous variables  $c$  and  $l$ ) in the equation system  $\tilde{\Gamma}_{r, u^2, \dots, u^H}(c, l) = 0$ , the proof of generic local uniqueness follows from a direct application of the transversality theorem.

<sup>41</sup> For a statement of the transversality theorem, see the appendix or GP.

<sup>42</sup> For example, in the one-hundred percent profit taxation case of Guesnerie [1998], which is equivalent to the case of a private ownership economy where  $\theta_i^h = \frac{1}{H}$  for all  $h$  and  $i \neq 0$ ,  $\tilde{\Gamma}_r^{-1}(0)$  is empty. On the other hand, BM given an example of an economy where all second-best (except those that are also first-best) tax equilibria are production and consumption inefficient.

<sup>43</sup>  $\tilde{\mathcal{R}}$  is open follows from Lemma SB4 and the transversality theorem.

**Theorem SBPCI2 (Generic Local Uniqueness):** *For almost all  $\langle r, u^2, \dots, u^H \rangle \in \mathcal{P}$ , except on a closed set of measure zero, we have  $\tilde{\Gamma}_{r, u^2, \dots, u^H}^{-1}(0)$  is manifold of dimension zero.*

## 7. The generic size and structure of the second-best production efficient (SBPE) but consumption inefficient subset of the second-best frontier.

In this section the generic size and structure of the production efficient but consumption inefficient component of the second-best Pareto manifold is established. In Section 5.2 it was shown that second-best production efficiency in the current regime may or may not imply positive welfare gains from shifting to a regime with firm-specific profit taxes. The size and structure of the SBPE component will vary depending on whether or not there are such gains. Denote the space of all Lagrange multipliers such that  $(\kappa^h)$  is not zero by  $\mathbf{R}_\kappa^{n_l}$ .<sup>44</sup> Given  $\langle r, u^2, \dots, u^H \rangle \in \mathcal{P}$ , from Lemmas SB1 and SB2 it follows that  $c \in \mathcal{C}$  is a production efficient and consumption inefficient second-best tax equilibrium if and only if there exists  $l \in \mathbf{R}_\kappa^{n_l}$  such that  $\langle c, l \rangle$  solves

$$\begin{bmatrix} \mathbf{\Gamma}(r, u^2, \dots, u^H, c, l) \\ \hat{p} - \frac{\hat{\beta}}{\beta_1} \end{bmatrix} = 0. \quad (7.1)$$

Define the mapping  $\bar{\Gamma} : \mathcal{P} \times \mathcal{C} \times \mathbf{R}_\kappa^{n_l} \rightarrow \mathbf{R}^{n_e + N - 1}$  with image

$$\bar{\Gamma}_{\mathbf{x}}^h((u^h)_{h \neq 1}, r, c, l) = \begin{bmatrix} \nabla_{x^h} U^h(x^h, a^h, A^h) - \lambda^h q \\ \alpha^h \lambda^h q - \psi^h q - \nabla_{x^h, x^h} U^h \kappa^h - \beta \end{bmatrix} \quad \forall h, \quad (2HN) \quad (7.2)$$

$$\bar{\Gamma}_{\mathbf{y}}^i((u^h)_{h \neq 1}, r, c, l) = \begin{bmatrix} F^i(y^i, b_0^i, b^i, B^i) \\ \nabla_{y^i} F^i(y^i, b_0^i, b^i, B^i) - \gamma^i \frac{\beta}{\beta_1} \\ (\mu^i \gamma^i - \beta_1 - \sum_h \psi^h \theta_i^h)_{i \neq 0} \end{bmatrix} \quad \forall i \neq 0, \quad (IN + 2I) \quad (7.3)$$

$$\bar{\Gamma}_{\mathbf{y}}^0((u^h)_{h \neq 1}, r, c, l) = \begin{bmatrix} F^0(y^0, b_0^0, b^0, B^0) \\ -\delta \nabla_{y^0} F^0 + \beta \end{bmatrix}, \quad (N + 1) \quad (7.4)$$

$$\bar{\Gamma}_{\beta}((u^h)_{h \neq 1}, r, c, l) = [\sum_h x^h - \sum_i y^i - \sum_h e^h], \quad (N) \quad (7.5)$$

$$\bar{\Gamma}_{\mathbf{R}}((u^h)_{h \neq 1}, r, c, l) = \sum_h \psi^h, \quad (1) \quad (7.6)$$

$$\bar{\Gamma}_{\mathbf{q}, \lambda, \psi}((u^h)_{h \neq 1}, r, c, l) = \begin{bmatrix} \sum_h \psi^h \sum_i \theta_i^h \hat{y}^i \\ (q^T x^h - R - \sum_i \theta_i^h \frac{\beta}{\beta_1} y^i - q^T e^h) \\ - \sum_h \psi^h [x^h - e^h] + \sum_h \kappa^h \lambda^h \\ (\kappa^h q)_h \end{bmatrix}, \quad (2N + 2H - 1) \quad (7.7)$$

<sup>44</sup> That is,  $\mathbf{R}_\kappa^{n_l} = \{l \in \mathbf{R}^{n_l} \mid \forall h, \kappa^h \neq 0\}$ .



$$\bar{\Gamma}_{\mathbf{u}}((u^h)_{h \neq 1}, r, c, l) = (u^h - U^h(x^h, a^h, A^h)), \quad (H-1) \quad (7.8)$$

$$\bar{\Gamma}_{*}((u^h)_{h \neq 1}, r, c, l) = \hat{p} - \frac{\hat{\beta}}{\beta_1}, \text{ and} \quad (N-1) \quad (7.9)$$

$$\bar{\Gamma}_{\phi}((u^h)_{h \neq 1}, r, c, l) = (\phi^i). \quad (IN) \quad (7.10)$$

Lemma SB1 showed that  $c$  is a production efficient stationary point if and only if the associated Lagrange multipliers  $\phi^i = 0$  for all  $i \neq 0$ . Hence, it can easily be verified that (7.1) is equivalent to  $\bar{\Gamma}((u^h)_{h \neq 1}, r, c, l) = 0$ . For every  $r \in \mathcal{R}$ , we define the following subset of  $U(r)$

$$\bar{U}(r) := \{\langle u^1, \dots, u^H \rangle \in U(r) \mid \exists \langle c, l \rangle \in \mathcal{C} \times \mathbf{R}_{\kappa}^{n_l} \text{ such that } \bar{\Gamma}(c, l, r, u^2, \dots, u^H) = 0\}. \quad (7.11)$$

This is the component of  $U(r)$  that is associated with production efficient but consumption inefficient second-best tax equilibria. Thus, in this component, the producer prices in the private sector reflect the social shadow prices. The following lemma will be useful in understanding the generic size and structure of  $\bar{U}(r)$ .

Partition the domain of  $\bar{\Gamma}$  into two subsets:

$$\mathcal{A} = \{\langle r, (u^h)_{h \neq 1}, c, l \rangle \in \mathcal{P} \times \mathcal{C} \times \mathbf{R}_{\kappa}^{n_l} \mid \exists i \neq 0 \text{ such that } \sum_h \psi^h \theta_h^i \neq 0\} \quad (7.12)$$

and

$$\mathcal{B} = \{\langle r, (u^h)_{h \neq 1}, c, l \rangle \in \mathcal{P} \times \mathcal{C} \times \mathbf{R}_{\kappa}^{n_l} \mid \sum_h \psi^h \theta_h^i = 0 \forall i \neq 0\}. \quad (7.13)$$

From Section 5.2 it follows that the restriction of  $\bar{\Gamma}$  to set  $\mathcal{A}$  is the case where there are no welfare gains from switching to a regime with firm-specific profit taxation, while the restriction to the set  $\mathcal{B}$  is the case where there are such welfare gains.

In Subsections 7.1 and 7.2 we establish generic local uniqueness and continuity of the map  $\Phi_r$  in the SBPE component of  $\mathbf{\Gamma}^{-1}(0)$  and in Subsection 7.3 we establish the generic size and structure of  $\bar{U}(r)$ .

*7.1. SBPE and generic local uniqueness and continuity of  $\Phi_r$ :  $\exists i \neq 0$  such that  $\sum_h \psi^h \theta_h^i \neq 0$ .*

We denote the restriction of  $\bar{\Gamma}$  to  $\mathcal{A}$  by  $\bar{\bar{\Gamma}}$ .

**Lemma SBPE1:**  $\bar{\bar{\Gamma}} \pitchfork 0$ .

Lemmas SB4, SBPE1, and the transversality theorem imply that, except on a closed set of measure zero in  $\mathcal{P}$ ,  $\bar{\Gamma}_{r,u^2,\dots,u^H} \cap 0$  for almost all  $\langle r, u^2, \dots, u^H \rangle \in \mathcal{P}$ . But, given any  $\langle r, u^2, \dots, u^H \rangle \in \mathcal{P}$ , the number of equations  $(n_e + N - 1)$  in  $\bar{\Gamma}_{r,u^2,\dots,u^H}(\cdot) = 0$  exceeds the number of unknowns  $(n_e)$  by  $N - 1$ .<sup>45</sup> Hence, from the transversality theorem it follows that  $\bar{\Gamma}_{r,u^2,\dots,u^H} \cap 0$  if and only if  $\bar{\Gamma}_{r,u^2,\dots,u^H}^{-1}(0)$  is an empty set.

This hints that, in this production efficient subset, there is no (locally) continuous relationship between  $\langle c, l \rangle$  and the utilities of *all* the  $H - 1$  consumers and  $r$ , that is, it is not generically possible to change  $r$  and the utilities of consumers  $2, \dots, H$  independently while moving in this subset. Let  $Q = \{2, \dots, H\}$  and let  $\bar{Q}$  denote any  $H - N$ -dimensional subset of  $Q$ . Let  $\mathcal{P}_{\bar{Q}}$  be the projection of  $\mathcal{P}$  to the space of  $r$  and  $(u^h)_{h \in \bar{Q}}$ . The number of equations in the system  $\bar{\Gamma}_{r,(u^h)_{h \in \bar{Q}}} = 0$  is  $n_e + N - 1$ , while the number of unknowns  $(c, l, \text{ and } (u^h)_{h \notin \bar{Q}})$  is also  $n_e + N - 1$ .<sup>46</sup>

**Theorem SBPE1 (Generic Local Uniqueness):** *If  $H \geq N$  then, for almost all  $\langle r, (u^h)_{h \in \bar{Q}} \rangle \in \mathcal{P}_{\bar{Q}}$ , except on a closed subset of  $\mathcal{P}_{\bar{Q}}$  of measure zero, we have  $\bar{\Gamma}_{r,(u^h)_{h \in \bar{Q}}} \cap 0$  and  $\bar{\Gamma}_{r,(u^h)_{h \in \bar{Q}}}^{-1}(0)$ , if not empty, is a manifold of dimension zero.*

The proof follows as an application of Lemmas SB4, SBPE2, and the transversality theorem. Theorem SBPE1 shows that in this case of production efficiency, there is a (locally) continuous relationship between  $\langle r, (u^h)_{h \in \bar{Q}} \rangle \in \mathcal{P}_{\bar{Q}}$  and  $\langle c, l, (u^h)_{h \notin \bar{Q}} \rangle$ , that is, moving along this production efficient subset implies that we can change  $r$  and only the utilities of  $H - N$  consumers independently.<sup>47</sup> This theorem also demonstrates local uniqueness when the solution to Problem (4.1) is production efficient.

7.2. *SBPE and generic local uniqueness and continuity of  $\Phi_r$ :  $\sum_h \psi^h \theta_i^h = 0$  for all  $i \neq 0$ .*

In this case one of the equations in  $\bar{\Gamma}((u^h)_{h \neq 1}, r, c, l) = 0$  is redundant. This is because, pre-multiplying the third set of equations in  $\bar{\Gamma}_{q,\lambda,\psi}((u^h)_{h \neq 1}, r, c, l) = 0$  by  $q^T$ , pre-multiplying the budget equation (see the second set of equations in  $\bar{\Gamma}_{q,\lambda,\psi}((u^h)_{h \neq 1}, r, c, l) =$

<sup>45</sup> The unknown/endogeneous variables are  $c$  and  $l$ .

<sup>46</sup> The dimension of the complement of  $\bar{Q}$  relative to  $Q$  is  $H - 1 - (H - N) = N - 1$ .

<sup>47</sup> Note, when combined with our maintained assumptions,  $N \geq 1$ ,  $H \geq 1$ , and  $N \geq H - 1$ , the condition  $H \geq N$  implies that  $H - N$  is either zero or one.

0) of consumer  $h$  by  $\psi^h$ , and adding, we obtain

$$\begin{aligned}
& q^T \left[ - \sum_h \psi^h [x^h - e^h] + \sum_h \kappa^h \lambda^h \right] + \sum_h \psi^h [q^t [x^h - e^h] - R - \sum_i \theta_i^h p^T y^i] \\
&= -q^T \sum_h \psi^h [x^h - e^h] + q^T \sum_h \kappa^h \lambda^h + q^T \sum_h \psi^h [x^h - e^h] - R \sum_h \psi^h - \sum_i p^T y^i \sum_h \psi^h \theta_i^h \\
&= 0.
\end{aligned} \tag{7.14}$$

The last equality in (7.14) follows from  $\bar{\Gamma}_{\mathbf{R}}((u^h)_{h \neq 1}, r, c, l) = 0$  and the last equation in  $\bar{\Gamma}_{\mathbf{q}, \boldsymbol{\lambda}, \boldsymbol{\psi}}((u^h)_{h \neq 1}, r, c, l) = 0$ , both of which hold when  $\bar{\Gamma}((u^h)_{h \neq 1}, r, c, l) = 0$ . Thus, without loss of generality, we can eliminate one equation, say the budget equation of consumer one ( $q^t [x^1 - e^1] - R - \sum_i \theta_i^1 p^T y^i = 0$ ), from  $\bar{\Gamma}$ .

With an abuse of notation, define the mapping  $\bar{\bar{\Gamma}} : \mathcal{B} \rightarrow \mathbf{R}^{ne+I-N}$ , with image  $\bar{\bar{\Gamma}}((u^h)_{h \neq 1}, r, c, l)$  as

$$\bar{\bar{\Gamma}}_{\mathbf{x}}^h(\cdot) = \bar{\Gamma}_{\mathbf{x}}^h(\cdot), \quad \forall h \tag{2HN} \tag{7.15}$$

$$\bar{\bar{\Gamma}}_{\mathbf{y}}^i(\cdot) = \bar{\Gamma}_{\mathbf{y}}^i(\cdot), \tag{IN + 2I} \tag{7.16}$$

$$\bar{\bar{\Gamma}}_{\mathbf{y}}^0(\cdot) = \bar{\Gamma}_{\mathbf{y}}^0(\cdot), \tag{N + 1} \tag{7.17}$$

$$\bar{\bar{\Gamma}}_{\boldsymbol{\beta}}(\cdot) = \bar{\Gamma}_{\boldsymbol{\beta}}(\cdot), \tag{N} \tag{7.18}$$

$$\bar{\bar{\Gamma}}_{\mathbf{R}}(\cdot) = \bar{\Gamma}_{\mathbf{R}}(\cdot), \tag{1} \tag{7.19}$$

$$\bar{\bar{\Gamma}}_{\mathbf{q}, \boldsymbol{\lambda}, \boldsymbol{\psi}}(\cdot) = \begin{bmatrix} (q^T x^h - R - \sum_i \theta_i^h p^T y^i - q^T e^h)_{h \neq 1} \\ - \sum_h \psi^h [x^h - e^h] + \sum_h \kappa^h \lambda^h \\ (\kappa^h p^T q) \\ (\sum_h \psi^h \theta_i^h)_{i \neq 0} \end{bmatrix}, \tag{N + 2H - 1 + I} \tag{7.20}$$

$$\bar{\bar{\Gamma}}_{\mathbf{u}}(\cdot) = \bar{\Gamma}_{\mathbf{u}}(\cdot), \quad \forall h \neq 1, \tag{H - 1} \tag{7.21}$$

$$\bar{\bar{\Gamma}}_{*}(\cdot) = \bar{\Gamma}_{*}(\cdot), \quad \text{and} \tag{N - 1} \tag{7.22}$$

$$\bar{\bar{\Gamma}}_{\boldsymbol{\phi}}(\cdot) = \bar{\Gamma}_{\boldsymbol{\phi}}(\cdot). \tag{IN} \tag{7.23}$$

It is easily verified that  $\bar{\Gamma}((u^h)_{h \neq 1}, r, c, l) = 0$  when  $\bar{\Gamma}$  is restricted to  $\mathcal{B}$  is equivalent to  $\bar{\bar{\Gamma}}((u^h)_{h \neq 1}, r, c, l) = 0$ .

**Lemma SBPE2:**  $\bar{\bar{\Gamma}} \pitchfork 0$ .

An analysis similar to the one in Section 7.1 can be repeated for this case, when we note that the number of equations  $(n_e + I - 1)$  in  $\bar{\bar{\Gamma}}_{r,u^2,\dots,u^H}(\cdot) = 0$  exceeds the number of unknowns  $(n_e)$  by  $I - 1$ . Let  $\bar{\bar{Q}}$  denote any  $H - I$ -dimensional subset of  $Q$ . Let  $\mathcal{P}_{\bar{\bar{Q}}}$  be the projection of  $\mathcal{P}$  to the space of  $r$  and  $(u^h)_{h \in \bar{\bar{Q}}}$ .

**Theorem SBPE2 (Generic Local Uniqueness):** *If  $H - I \geq 0$  then, for almost all  $\langle r, (u^h)_{h \in \bar{\bar{Q}}} \rangle \in \mathcal{P}_{\bar{\bar{Q}}}$ , except on a closed subset of  $\mathcal{P}_{\bar{\bar{Q}}}$  of measure zero, we have  $\bar{\bar{\Gamma}}_{r,(u^h)_{h \in \bar{\bar{Q}}}} \pitchfork 0$  and  $\bar{\bar{\Gamma}}_{r,(u^h)_{h \in \bar{\bar{Q}}}}^{\bar{\bar{-1}}}(0)$ , if not empty, is a manifold of dimension zero.*

### 7.3. The generic structure of $\bar{U}(r)$ .

For every  $r \in \mathcal{R}$ , define the following subsets of  $U(r)$ :

$$\bar{U}(r) := \{ \langle u^1, \dots, u^H \rangle \in U(r) \mid \exists \langle c, l \rangle \in \mathcal{C} \times \mathbf{R}_{\kappa}^{n_l} \text{ such that } \bar{\Gamma}(c, l, r, u^2, \dots, u^H) = 0 \}. \quad (7.24)$$

and

$$\bar{\bar{U}}(r) := \{ \langle u^1, \dots, u^H \rangle \in U(r) \mid \exists \langle c, l \rangle \in \mathcal{C} \times \mathbf{R}_{\kappa}^{n_l} \text{ such that } \bar{\bar{\Gamma}}(c, l, r, u^2, \dots, u^H) = 0 \}. \quad (7.25)$$

**Remark SBPE1.** From the transversality theorem, Lemmas SB4 and SBPE1 imply that, for almost all  $r \in \mathcal{R}$ , except on a closed subset of measure zero,  $\bar{\Gamma}_r \pitchfork 0$ . If  $\bar{\Gamma}_r \pitchfork 0$  then  $\bar{\Gamma}_r^{\bar{-1}}(0)$ , if not an empty set, is a smooth manifold of dimension  $H - N$ . Let  $\bar{\mathcal{R}} := \{ r \in \mathcal{R} \mid \bar{\Gamma}_r \pitchfork 0 \}$ . Then  $\bar{\mathcal{R}}$  is open and dense in  $\mathcal{R}$ .

**Remark SBPE2.** From the transversality theorem, Lemmas SB4 and SBPE2 imply that, for almost all  $r \in \mathcal{R}$ , except on a closed subset of measure zero,  $\bar{\bar{\Gamma}}_r \pitchfork 0$ . If  $\bar{\bar{\Gamma}}_r \pitchfork 0$  then  $\bar{\bar{\Gamma}}_r^{\bar{\bar{-1}}}(0)$ , if not an empty set, is a smooth manifold of dimension  $H - I$ . Let  $\bar{\bar{\mathcal{R}}} := \{ r \in \mathcal{R} \mid \bar{\bar{\Gamma}}_r \pitchfork 0 \}$ . Then  $\bar{\bar{\mathcal{R}}}$  is open and dense in  $\mathcal{R}$ .

The proof of Theorem SBPE3, below, is exactly similar to the proof of Theorem SBPCII. It involves applying the homeomorphism  $\zeta$  to lower dimensional submanifolds of the graph of  $\bar{\Phi}_r^*$ . This implies that the images of  $\zeta$ , restricted to these submanifolds, are lower dimensional submanifolds of  $U(r)$ .

**Theorem SBPE3:** *Let Assumptions SB1 and SB2 hold. If  $H \geq N$  then for every  $r \in \bar{\mathcal{R}}$ , we have  $\bar{U}(r)$ , if not empty, is a  $H - N$ -dimensional submanifold of  $U(r)$ . If  $H \geq I$  then for every  $r \in \bar{\bar{\mathcal{R}}}$ , we have  $\bar{\bar{U}}(r)$ , if not empty, is a  $H - I$ -dimensional submanifold of  $U(r)$ .*

The following theorem establishes the generic size and structure of  $\bar{U}(r)$  (which is the union of  $\bar{U}(r)$  and  $\bar{\bar{U}}(r)$ ) when we note that  $\bar{\mathcal{R}} \cup \bar{\bar{\mathcal{R}}}$  is open and has full Lebesgue measure in the set  $\mathcal{R}$ .

**Theorem SBPE4:** *Let Assumptions SB1 and SB2 hold. For almost all  $r \in \mathcal{R}$ , except on a closed subset of measure zero,  $\bar{U}(r)$  is either an empty set or a union of manifolds of dimensions  $H - N$  and  $H - I$ .*

In BM it was demonstrated that for any economy  $r \in \mathcal{R}$ , where the rank of the matrix of shares  $\Theta$  was one, every second-best is production efficient, that is,  $\bar{U}(r) = U(r)$ , and hence  $\bar{U}(r)$  is a  $H - 1$ -dimensional manifold.<sup>48</sup> Since, second-best production efficient sets are generically of dimensions  $H - I$  or  $H - N$ , the economies for which the second-best production sets are of dimension  $H - 1$  must be critical economies. The following result, hence, follows as a Corollary to Theorem SBPE4.

**Corollary SBPE4:** *Under Assumptions SB1 and SB2, the set*

$$\{r \in \mathcal{R} | \bar{U}(r) \text{ is a } H - 1\text{-dimensional manifold}\} \quad (7.26)$$

*has Lebesgue measure zero in  $\mathcal{R}$ . In particular,*

$$\{r \in \mathcal{R} | \theta_i^h = \theta^h \forall h\} \subset \{r \in \mathcal{R} | \bar{U}(r) \text{ is a } H - 1\text{-dimensional manifold}\}. \quad (7.27)$$

## 8. The generic size and structure of the second-best consumption efficient (SBCE) but production inefficient subset of the second-best frontier.

In this section the generic size and structure of the consumption efficient but production inefficient component of the second-best Pareto manifold is established. Denote the space of all Lagrange multipliers such that  $(\phi^i)_{i \neq 0}$  is not zero by  $\mathbf{R}_\phi^{n_l}$ .<sup>49</sup> Given  $\langle r, u^2, \dots, u^H \rangle \in \mathcal{P}$ , from Lemmas SB1 and SB2 it follows that  $c \in \mathcal{C}$  is a consumption efficient and production inefficient second-best tax equilibrium if and only if there exists  $l \in \mathbf{R}_\phi^{n_l}$  such that  $\langle c, l \rangle$  solves

$$\begin{bmatrix} \mathbf{\Gamma}(r, u^2, \dots, u^H, c, l) \\ \frac{\hat{q}}{q_1} - \frac{\hat{\beta}}{\beta_1} \end{bmatrix} = 0, \quad (8.1)$$

Define the mapping  $\hat{\mathbf{\Gamma}} : \mathcal{P} \times \mathcal{C} \times \mathbf{R}_\phi^{n_l} \rightarrow \mathbf{R}^{ne+N-1}$  with image

$$\hat{\mathbf{\Gamma}}_{\mathbf{x}}^h((u^h)_{h \neq 1}, r, c, l) = \begin{bmatrix} \nabla_{x^h} U^h(x^h, a^h, A^h) - \lambda^h q \\ \alpha^h \lambda^h - \psi^h - \frac{\beta_1}{q_1} \end{bmatrix} \forall h, \quad (HN + H) \quad (8.2)$$

$$\hat{\mathbf{\Gamma}}_{\mathbf{y}}^i((u^h)_{h \neq 1}, r, c, l) = \begin{bmatrix} F^i(y^i, b_0^i, b^i, B^i) \\ \nabla_{y^i} F^i(y^i, b_0^i, b^i, B^i) - \gamma^i p \\ \sum_h \psi^h \theta_i^h p - \mu^i \gamma^i p - \nabla_{y^i, y^i} F^i \phi^i + \beta \end{bmatrix} \forall i, \quad (2IN + I) \quad (8.3)$$

<sup>48</sup> Note, the DM case and the case with one-hundred percent profit taxation are special cases of this rank condition.

<sup>49</sup> That is,  $\mathbf{R}_\phi^{n_l} = \{l \in \mathbf{R}^{n_l} | \forall i \neq 0, \phi^i \neq 0\}$ .

$$\hat{\mathbf{\Gamma}}_{\mathbf{y}}^0((u^h)_{h \neq 1}, r, c, l) = \begin{bmatrix} F^0(y^0, b_0^0, b^0, B^0) \\ -\delta \nabla_{y^0} F^0 + \beta \end{bmatrix}, \quad (N+1) \quad (8.4)$$

$$\hat{\mathbf{\Gamma}}_{\boldsymbol{\beta}}((u^h)_{h \neq 1}, r, c, l) = [\sum_h x^h - \sum_i y^i - \sum_h e^h], \quad (N) \quad (8.5)$$

$$\hat{\mathbf{\Gamma}}_{\mathbf{p}, \boldsymbol{\gamma}}((u^h)_{h \neq 1}, r, c, l) = \begin{bmatrix} (\phi^{iT} p)_{i \neq 0} \\ \sum_h \psi^h \sum_i \theta_i^h \hat{y}^i + \sum_i \hat{\phi}^i \gamma^i \end{bmatrix}, \quad ((N-1) + I) \quad (8.6)$$

$$\hat{\mathbf{\Gamma}}_{\mathbf{q}, \boldsymbol{\lambda}, \boldsymbol{\psi}}((u^h)_{h \neq 1}, r, c, l) = \begin{bmatrix} (q^T x^h - R - \sum_i \theta_i^h p^T y^i - q^T e^h) \\ -\sum_h \psi^h [x^h - e^h] \end{bmatrix}, \quad (N+H) \quad (8.7)$$

$$\hat{\mathbf{\Gamma}}_{\mathbf{R}}((u^h)_{h \neq 1}, r, c, l) = \sum_h \psi^h, \quad (1) \quad (8.8)$$

$$\hat{\mathbf{\Gamma}}_{\mathbf{u}}((u^h)_{h \neq 1}, r, c, l) = (u^h - U^h(x^h, a^h, A^h)), \quad (H-1) \quad (8.9)$$

$$\hat{\mathbf{\Gamma}}_{*}((u^h)_{h \neq 1}, r, c, l) = \frac{\hat{q}}{q_1} - \frac{\hat{\beta}}{\beta_1}, \quad \text{and} \quad (N-1) \quad (8.10)$$

$$\hat{\mathbf{\Gamma}}_{\boldsymbol{\kappa}}((u^h)_{h \neq 1}, r, c, l) = (\boldsymbol{\kappa}^h). \quad (HN) \quad (8.11)$$

Recalling that Lemma SB2 said that  $c$  is a consumption efficient second-best if and only if  $\boldsymbol{\kappa}^h = 0$  for all  $h$ , it is clear that (8.1) is equivalent to  $\hat{\mathbf{\Gamma}}(r, u^2, \dots, u^H, c, l) = 0$ . Following methods similar to the previous sections, it is straightforward to establish that (i)  $\hat{\mathbf{\Gamma}} \pitchfork 0$ , (ii) for almost all  $r \in \mathcal{R}$  except on a closed subset of measure zero,  $\hat{\mathbf{\Gamma}}_r \pitchfork 0$  and  $\hat{\mathbf{\Gamma}}_r^{-1}(0)$ , if not an empty set, is a smooth manifold of dimension  $H - N$ . Define  $\hat{\mathcal{R}} := \{r \in \mathcal{R} | \hat{\mathbf{\Gamma}}_r \pitchfork 0\}$ . Then  $\hat{\mathcal{R}}$  is open and dense in  $\mathcal{R}$ , (iii)  $\Phi_r$  is generically locally unique and continuous in the SBCE component of  $\mathbf{\Gamma}^{-1}(0)$ , and (iv) for all  $r \in \hat{\mathcal{R}}$ ,  $\hat{U}(r)$ , if not empty, is a  $H - N$ -dimensional submanifold of  $U(r)$ , where

$$\hat{U}(r) := \{(u^1, \dots, u^H) \in U(r) | \exists \langle c, l \rangle \in \mathcal{C} \times \mathbf{R}_{\phi}^{n_l} \text{ such that } \hat{\mathbf{\Gamma}}(c, l, r, u^2, \dots, u^H) = 0\}. \quad (8.12)$$

## 9. The generic size and structure of the first-best (FB) tax equilibria.

First-best tax equilibria of private ownership economies are tax equilibria where the producer and consumer prices are both proportional to the shadow prices of the resources in the economy (or equivalently, to the shadow prices in the public sector), and where the wedge (the constant of proportionality) between consumer and producer prices generates indirect tax revenue to the government, which the government can use to finance public sector production or distribute as a uniform lump-sum transfer. In the usual competitive equilibria of private ownership economies the constant of proportionality between  $q$  and  $p$  is one. We show that, generically, the first-best subset of  $U(r)$  is a one-dimensional manifold.

Given  $\langle r, u^2, \dots, u^H \rangle \in \mathcal{P}$ , from Lemmas SB1 and SB2, it follows that  $c \in \mathcal{C}$  is a consumption and production efficient second-best tax equilibrium if and only if there exists  $l \in \mathbf{R}^{n_l}$  such that  $\langle c, l \rangle$  solves

$$\begin{bmatrix} \mathbf{\Gamma}(r, u^2, \dots, u^H, c, l) \\ \hat{p} - \frac{\hat{\beta}}{\beta_1} \\ \frac{\hat{q}}{q_1} - \frac{\hat{\beta}}{\beta_1} \end{bmatrix} = 0. \quad (9.1)$$

Lemmas SB1 to SB3 imply that if  $c$  is a production and consumption efficient second-best, then  $\kappa^h = 0$  for all  $h$ ,  $\phi^i = 0$  for all  $i \neq 0$ , and  $\psi^h = 0$  for all  $h$ . Define the mapping  $\check{\mathbf{\Gamma}} : \mathcal{P} \times \mathcal{C} \times \mathbf{R}^{n_l} \rightarrow \mathbf{R}^{n_e + H - 2}$  with image

$$\check{\mathbf{\Gamma}}_{\mathbf{x}}^h((u^h)_{h \neq 1}, r, c, l) = \begin{bmatrix} \nabla_{x^h} U^h(x^h, a^h, A^h) - \lambda^h q \\ \alpha^h \lambda^h - \psi^h - \frac{\beta_1}{q_1} \end{bmatrix} \quad \forall h, \quad (HN + H) \quad (9.2)$$

$$\check{\mathbf{\Gamma}}_{\mathbf{y}}^i((u^h)_{h \neq 1}, r, c, l) = \begin{bmatrix} F^i(y^i, b_0^i, b^i, B^i) \\ \nabla_{y^i} F^i(y^i, b_0^i, b^i, B^i) - \gamma^i p \\ \mu^i \gamma^i - \beta_1 \end{bmatrix} \quad \forall i, \quad (IN + 2I) \quad (9.3)$$

$$\check{\mathbf{\Gamma}}_{\mathbf{y}}^0((u^h)_{h \neq 1}, r, c, l) = \begin{bmatrix} F^0(y^0, b_0^0, b^0, B^0) \\ -\delta \nabla_{y^0} F^0 + \beta \end{bmatrix}, \quad (N + 1) \quad (9.4)$$

$$\check{\mathbf{\Gamma}}_{\boldsymbol{\beta}}((u^h)_{h \neq 1}, r, c, l) = [\sum_h x^h - \sum_i y^i - \sum_h e^h], \quad (N) \quad (9.5)$$

$$\check{\mathbf{\Gamma}}_{\mathbf{q}, \boldsymbol{\lambda}}((u^h)_{h \neq 1}, r, c, l) = [(q^T x^h - R - \sum_i \theta_i^h p^T y^i - q^T e^h)] \quad (H) \quad (9.6)$$

$$\check{\mathbf{\Gamma}}_{\mathbf{u}}((u^h)_{h \neq 1}, r, c, l) = (u^h - U^h(x^h, a^h, A^h)) \quad (H - 1) \quad (9.7)$$

$$\check{\mathbf{\Gamma}}_{\mathbf{q}}((u^h)_{h \neq 1}, r, c, l) = \frac{\hat{q}}{q_1} - \frac{\hat{\beta}}{\beta_1} \quad (N - 1) \quad (9.8)$$

$$\check{\mathbf{\Gamma}}_{\mathbf{p}}((u^h)_{h \neq 1}, r, c, l) = \hat{p} - \hat{\beta} \quad (N - 1) \quad (9.9)$$

$$\check{\mathbf{\Gamma}}_{\boldsymbol{\kappa}}((u^h)_{h \neq 1}, r, c, l) = (\kappa^h) \quad (HN) \quad (9.10)$$

$$\check{\mathbf{\Gamma}}_{\boldsymbol{\psi}}((u^h)_{h \neq 1}, r, c, l) = (\psi^h) \quad (H) \quad (9.11)$$

$$\check{\mathbf{\Gamma}}_{\boldsymbol{\phi}}((u^h)_{h \neq 1}, r, c, l) = (\phi^i)_{i \neq 0} \quad (IN) \quad (9.12)$$

It is clear that (9.1) is equivalent to  $\check{\mathbf{\Gamma}}(r, u^2, \dots, u^H, c, l) = 0$ . It is straightforward to prove that  $\check{\mathbf{\Gamma}} \pitchfork 0$ . From that it follows that, for almost all  $r \in \mathcal{R}$ , except on a closed subset of measure zero, we have  $\check{\mathbf{\Gamma}}_r \pitchfork 0$ . We define  $\check{\mathcal{R}}$  in a manner similar to the earlier sections. This set is open and dense in  $\mathcal{R}$ . For all  $r \in \check{\mathcal{R}}$ , by counting the number of equations and the number of unknowns in  $\check{\mathbf{\Gamma}}_r(c, l, u^2, \dots, u^H) = 0$  and applying the transversality theorem, we can show that  $\check{\mathbf{\Gamma}}_r^{-1}(0)$ , if not an empty set, is a smooth manifold of dimension

one. We can also apply the transversality theorem, as in the previous sections, to show the local uniqueness and continuity of the stationary values of Problem (4.1) in the FB component of  $\mathbf{\Gamma}^{-1}(0)$ . Moreover, if, for every  $r \in \mathcal{R}$ , we define the following FB subset of  $U(r)$ ,

$$\check{U}(r) := \{ \langle u^1, \dots, u^H \rangle \in U(r) \mid \exists \langle c, l \rangle \in \mathcal{C} \times \mathbf{R}^n \text{ such that } \check{\mathbf{\Gamma}}(c, l, r, u^2, \dots, u^H) = 0 \}, \quad (9.13)$$

then for all  $r \in \check{\mathcal{R}}$ ,  $\check{U}(r)$  is a one-dimensional submanifold of  $U(r)$ .

## 10. Conclusions.

There seem three main difficulties that make a systematic study of the generic size and structure of the Pareto frontiers of second-best economies hard (i) the preferences of the consumers expressed in the dual space of the policy instruments that parametrize equilibria in second-best economies could be nonconvex. This leads to problems of multiplicity of solutions and discontinuities in the solution mapping of the second-best Pareto problem, (ii) second-best problems, when posed in the dual space of policy instruments, do not easily allow a rich enough set of perturbations in the fundamentals (the data) of the economy for establishing generic results, and (iii) for the second-best Pareto frontier to have the expected feature of a  $H - 1$ -dimensional manifold in economies with  $H$  consumers, a necessary condition is to be able to change, independently and in a manner that is equilibrium preserving, the utilities of  $H - 1$  consumers, that is, the constraint set of the second-best Pareto problem should be well defined on an open subset of the space of utilities of  $H - 1$  consumers, which is the parameter space of the optimization problem.

In this paper we study a simple second-best situation motivated by the inability of the government to implement personalized lump-sum transfers. Rather, the government has recourse to linear commodity taxes and a uniform lump-sum transfer in private ownership economies. We identify conditions under which the second-best Pareto frontier will be a  $H - 1$ -dimensional manifold, despite the nonconvexities in the indirect preferences of the consumers.

By posing the problem in the space of both the primal and dual variables, we are able to identify a class of economies which allows a rich enough set of perturbations in the fundamentals of the economy that yields the required generic results. Precisely, these perturbations are in the zero<sup>th</sup>, the first, and the second-order derivatives of utility and production functions. This helps in overcoming problem (ii) above.

In order to apply the theorem of Lagrange/Kuhn-Tucker to solve the second-best Pareto optimization problem, the constraint qualification condition should be met. In our case, this condition will hold if the government has recourse to at least  $H - 1$  policy instruments to independently change utilities of  $H - 1$  of the  $H$  consumers. We also identify a condition that ensures that such changes in utilities can be realized as tax equilibria. Thus, if the constraint qualification is satisfied, then it also ensures that (iii) above is met.



We distinguish between the stationary and solution values of the second-best Pareto optimization problem. With respect to (i) above, we show that, if the mapping of stationary values (that is, those values of choice variables that solve the first-order conditions of the Pareto problem) is locally unique (even if it is not a singleton set because of nonconvexities in indirect preferences) and continuous, then the value function  $\mathcal{V}$  of the Pareto problem is continuous in the utilities of  $H - 1$  consumers, so that the second-best utility possibility frontier is a  $H - 1$ -dimensional manifold. Examining the various components of the graph of the mapping of stationary values reveals that this mapping is, generically, locally unique and continuous.

Local continuity of the solution mapping is not required to prove the continuity of  $\mathcal{V}$ . However, if the solution mapping is also locally continuous, then our results demonstrate that, in the class of economies and under the conditions that we have identified, generically (that is, in an open and dense subset of our class of economies), the production efficient but consumption inefficient, consumption efficient but production inefficient, and the first-best subsets of the second-best Pareto manifold are either empty sets or lower dimensional (and, hence, negligible in size) submanifolds. On the other hand, its jointly production and consumption inefficient subset is a  $H - 1$ -dimensional submanifold. This indicates that economies such as those that are often studied in the literature, where every second-best is production (or consumption) efficient, are extremely rare. Most economies and most of the second-best equilibria in such economies exhibit production and consumption inefficiencies, so that market prices cannot be used in lieu of the social shadow prices for evaluating prospective public sector projects. This begs an answer to the following important question to be taken up in the future for further research: how can one recover the true social shadow prices in such economies from the data on the fundamentals of the economy and the available policy instruments?

## APPENDIX

**Transversality Theorem:** *Let  $A$ ,  $B$ , and  $C$  be smooth manifolds of dimension  $m$ ,  $n$ , and  $l$ , respectively, and  $f : A \times B \rightarrow C$  be a smooth mapping of manifolds with image  $f(a, b) = c$ . If  $f \pitchfork 0$  then  $f_a \pitchfork 0$  for almost all  $a \in A$  except on a subset of  $A$  of measure zero and  $f_a^{-1}(0)$  is either a manifold of dimension  $n - l$  or is an empty set. If  $f^{-1}(0) \subset A \times K$  where  $K$  is compact and  $B \subset K$ , then  $f_a \pitchfork 0$  for almost all  $a \in A$  except on a closed subset of  $A$  of measure zero.*

The proofs of most lemmas in this paper often require showing that the Jacobian matrices of some vector-valued functions are full-row ranked. To demonstrate this, we take recourse to Lemma FRR, which is proved below. Lemma FRR identifies a set of sufficient conditions under which the Jacobian matrix of a vector valued function  $L$  is full-row ranked. Most of the vector valued functions in our paper will satisfy these conditions.<sup>50</sup>

---

<sup>50</sup> Lemma FRR is a formalization of the methodology used in papers such as V et al. and CP to prove that Jacobian matrices of a class of functions can be shown to be full-row ranked.

Let  $L : \mathbf{R}^N \rightarrow \mathbf{R}^M$  be a vector-valued function with components

$$\begin{bmatrix} L^1 : \mathbf{R}^N \rightarrow \mathbf{R}^{M_1} \\ \vdots \\ L^T : \mathbf{R}^N \rightarrow \mathbf{R}^{M_T} \end{bmatrix}. \quad (\text{A.1})$$

Thus,  $\sum_{t=1}^T M_t = M$ . Suppose  $N \geq M$  and the set of arguments of  $L$  is  $\{x_1, \dots, x_N\} =: X$ . Let  $n_1, \dots, n_T$  be  $T$  positive integers such that  $\sum_{t=1}^T n_t \leq N$ . With a slight abuse of notation, we define the following  $T$  subsets of  $X$ :

$$\begin{aligned} n_1 &:= \{x_1, \dots, x_{n_1}\}, \\ n_2 &:= \{x_{n_1+1}, \dots, x_{n_1+n_2}\}, \\ &\vdots \\ n_T &:= \{x_{\sum_{t=1}^{T-1} n_t+1}, \dots, x_{\sum_{t=1}^{T-1} n_t+n_T}\}. \end{aligned} \quad (\text{A.2})$$

Define the set  $\mathbf{n}_t = \cup_{t'=1}^t n_{t'}$  and the set  $\mathbf{n}^c = X \setminus \mathbf{n}_T$ . Then the collection of subsets of  $X$   $\{n_1, \dots, n_T, \mathbf{n}^c\}$  is a partition of  $X$ . For all  $t = 1, \dots, T$ , we define the vector valued function

$$\mathcal{L}^t : \mathbf{R}^N \rightarrow \mathbf{R}^{\sum_{t'=1}^t M_{t'}} := \begin{bmatrix} L^1 : \mathbf{R}^N \rightarrow \mathbf{R}^{M_1} \\ \vdots \\ L^t : \mathbf{R}^N \rightarrow \mathbf{R}^{M_t} \end{bmatrix}. \quad (\text{A.3})$$

**Lemma Full-Row Rank (FRR):** *Let  $x \in \mathbf{R}^N$ . Suppose for all  $t = 1, \dots, T$ ,  $\nabla_{\mathbf{n}_{t-1}} L^t(x) = 0$  and  $\nabla_{\mathbf{n}_t} L^t(x)$  is full row-ranked. Then  $\nabla L(x)$  is full row-ranked.*

**Proof:** For all  $t = 1, \dots, T$ , since  $\nabla_{\mathbf{n}_t} L^t(x)$  is full row-ranked, there exist  $|\mathbf{n}_t| \times M_t$ -dimensional matrix of perturbations  $Z_t$  such that  $\nabla_{\mathbf{n}_t} L^t(x) Z_t = \mathcal{I}_{M_t}$ .<sup>51</sup>

We will prove by induction that for every  $t = 1, \dots, T-1$ , there exists a  $|\mathbf{n}_t| \times \sum_{t'=1}^t M_{t'}$ -dimensional matrix  $\mathcal{Z}_t$  and a  $\sum_{t'=1}^t M_{t'} \times M_{t+1}$ -dimensional matrix  $\mathcal{A}_t$  such that<sup>52</sup>

$$\begin{bmatrix} \nabla_{\mathbf{n}_t} \mathcal{L}^t & \nabla_{\mathbf{n}_{t+1}} \mathcal{L}^t \\ \nabla_{\mathbf{n}_t} L^{t+1} & \nabla_{\mathbf{n}_{t+1}} L^{t+1} \end{bmatrix} \begin{bmatrix} Z_t & Z_t \mathcal{A}_t \\ 0 & Z_{t+1} \end{bmatrix} = \mathcal{I}_{\sum_{t'=1}^{t+1} M_{t'}}. \quad (\text{A.4})$$

We first show that (A.4) holds for  $t = 1$ . In this case  $\mathcal{L}^1 = L^1$ . Choose  $\mathcal{Z}_1 = Z_1$ . Since  $\nabla_{\mathbf{n}_1} L^1$  is full ranked and  $\nabla_{\mathbf{n}_1} L^1 Z_1 = \mathcal{I}_{M_1}$ , there exists a  $M_1 \times M_2$ -dimensional matrix  $\mathcal{A}_1$  such that  $\nabla_{\mathbf{n}_2} L^1 Z_2 + \nabla_{\mathbf{n}_1} L^1 Z_1 \mathcal{A}_1 = \nabla_{\mathbf{n}_2} L^1 Z_2 + \mathcal{I}_{M_1} \mathcal{A}_1 = 0$ . (Clearly,  $\mathcal{A}_1 = -\nabla_{\mathbf{n}_2} L^1 Z_2$ .) Under the maintained hypothesis of the lemma,  $\nabla_{\mathbf{n}_1} L^2 = 0$ . Thus, we have

$$\begin{bmatrix} \nabla_{\mathbf{n}_1} \mathcal{L}^1 & \nabla_{\mathbf{n}_2} \mathcal{L}^1 \\ \nabla_{\mathbf{n}_1} L^2 & \nabla_{\mathbf{n}_2} L^2 \end{bmatrix} \begin{bmatrix} Z_1 & Z_1 \mathcal{A}_1 \\ 0 & Z_2 \end{bmatrix} = \begin{bmatrix} \mathcal{I}_{M_1} & 0 \\ 0 & \mathcal{I}_{M_2} \end{bmatrix} = \mathcal{I}_{\sum_{t'=1}^2 M_{t'}}. \quad (\text{A.5})$$

<sup>51</sup>  $|\mathbf{n}_t|$  is the cardinality of the set  $\mathbf{n}_t$ .

<sup>52</sup> In what follows, to save on notation, we omit writing  $x$  explicitly, though it is assumed that  $L$  is evaluated at  $x$ .

So (A.4) holds for  $t = 1$ . Suppose it holds for  $\bar{t} < T$ . We show that it holds for  $\bar{t} + 1$ . Since it holds for  $\bar{t} < T$ , there exists a  $|\mathbf{n}_{\bar{t}}| \times \sum_{t'=1}^{\bar{t}} M_{t'}$ -dimensional matrix  $\mathcal{Z}_{\bar{t}}$  and a  $\sum_{t'=1}^{\bar{t}} M_{t'} \times M_{\bar{t}+1}$ -dimensional matrix  $\mathcal{A}_{\bar{t}}$  such that

$$\begin{bmatrix} \nabla_{\mathbf{n}_{\bar{t}}} \mathcal{L}^{\bar{t}} & \nabla_{n_{\bar{t}+1}} \mathcal{L}^{\bar{t}} \\ \nabla_{\mathbf{n}_{\bar{t}}} L^{\bar{t}+1} & \nabla_{n_{\bar{t}+1}} L^{\bar{t}+1} \end{bmatrix} \begin{bmatrix} \mathcal{Z}_{\bar{t}} & \mathcal{Z}_{\bar{t}} \mathcal{A}_{\bar{t}} \\ 0 & \mathcal{Z}_{\bar{t}+1} \end{bmatrix} = \mathcal{I}_{\sum_{t'=1}^{\bar{t}+1} M_{t'}}. \quad (\text{A.6})$$

The first matrix on the left-side of (A.6) is  $\nabla_{\mathbf{n}_{\bar{t}+1}} \mathcal{L}^{\bar{t}+1}$ . Let us denote the second matrix on the left side of (A.6) by  $\mathcal{Z}_{\bar{t}+1}$ . Then (A.6) is equivalent to

$$\nabla_{\mathbf{n}_{\bar{t}+1}} \mathcal{L}^{\bar{t}+1} \mathcal{Z}_{\bar{t}+1} = \mathcal{I}_{\sum_{t'=1}^{\bar{t}+1} M_{t'}}. \quad (\text{A.7})$$

Therefore there exists a  $\sum_{t'=1}^{\bar{t}+1} M_{t'} \times M_{\bar{t}+2}$ -dimensional matrix  $\mathcal{A}_{\bar{t}+1}$  such that  $\nabla_{\mathbf{n}_{\bar{t}+1}} \mathcal{L}^{\bar{t}+1} \mathcal{Z}_{\bar{t}+1} \mathcal{A}_{\bar{t}+1} + \nabla_{\mathbf{n}_{\bar{t}+2}} L^{\bar{t}+1} \mathcal{Z}_{\bar{t}+2} = 0$ . (Simply choose  $\mathcal{A}_{\bar{t}+1} = -\nabla_{\mathbf{n}_{\bar{t}+2}} L^{\bar{t}+1} \mathcal{Z}_{\bar{t}+2}$ ). Further, under the maintained hypothesis of the lemma,  $\nabla_{\mathbf{n}_{\bar{t}+1}} L^{\bar{t}+2} = 0$ . Thus, for  $t = \bar{t} + 1$ , (A.4) holds as

$$\begin{bmatrix} \nabla_{\mathbf{n}_{\bar{t}+1}} \mathcal{L}^{\bar{t}+1} & \nabla_{n_{\bar{t}+2}} \mathcal{L}^{\bar{t}+1} \\ \nabla_{\mathbf{n}_{\bar{t}+1}} L^{\bar{t}+2} & \nabla_{n_{\bar{t}+2}} L^{\bar{t}+2} \end{bmatrix} \begin{bmatrix} \mathcal{Z}_{\bar{t}+1} & \mathcal{Z}_{\bar{t}+1} \mathcal{A}_{\bar{t}+1} \\ 0 & \mathcal{Z}_{\bar{t}+2} \end{bmatrix} = \mathcal{I}_{\sum_{t'=1}^{\bar{t}+2} M_{t'}}. \quad (\text{A.8})$$

Thus, (A.4) is true for all  $t = 1, \dots, T - 1$ . In particular, it holds for  $t = T - 1$  as

$$\begin{bmatrix} \nabla_{\mathbf{n}_{T-1}} \mathcal{L}^{T-1} & \nabla_{n_T} \mathcal{L}^{T-1} \\ \nabla_{\mathbf{n}_{T-1}} L^T & \nabla_{n_T} L^T \end{bmatrix} \begin{bmatrix} \mathcal{Z}_{T-1} & \mathcal{Z}_{T-1} \mathcal{A}_{T-1} \\ 0 & \mathcal{Z}_T \end{bmatrix} = \mathcal{I}_M. \quad (\text{A.9})$$

But this is equivalent to

$$\nabla_{\mathbf{n}_T} L \begin{bmatrix} \mathcal{Z}_{T-1} & \mathcal{Z}_{T-1} \mathcal{A}_{T-1} \\ 0 & \mathcal{Z}_T \end{bmatrix} = \mathcal{I}_M. \quad (\text{A.10})$$

Hence,  $\nabla_{\mathbf{n}_T} L$  is full-row ranked. Since  $\nabla_{\mathbf{n}_T} L$  is a  $M$ -rowed sub-matrix of  $\nabla L$ , the above implies that  $\nabla L(x)$  is full row-ranked. ■

**Proof of Lemma CQ:** *Step 1:* We show that  $\bar{\mathbf{G}} \pitchfork 0$ .

Assume, without loss of generality,  $H = 3$ ,  $I = 2$ , and  $N = 2$ .<sup>53</sup> Let  $\bar{\mathbf{G}}(c, u^2, \dots, u^H, r) = 0$ . We apply FRR with  $T = 4$ ,  $M_1 = 6$ ,  $M_2 = 8$ ,  $M_3 = 3$ , and  $M_4 = 3$ ,  $n_1 = \{y^0, x^1, \lambda^1\}$ ,  $n_2 = \{x^2, \lambda^2, x^3, \lambda^3, q\}$ ,  $n_3 = \{y^1, \gamma^1\}$ , and  $n_4 = \{y^2, \gamma^2\}$ ,

$$L^1() = \begin{bmatrix} \nabla_{x^1} U^1(x^1, a^1, A^1) - \lambda^1 q \\ q^T x^1 - R - \sum_{i \neq 0} \theta_i^1 p^T y^i - q^T e^1 \\ F^0(y^0, b_0^0, b^0, B^0) \\ \sum_h x^h - \sum_i y^i - \sum_h e^h \end{bmatrix}, \quad (\text{A.11})$$

<sup>53</sup> Note, the condition  $H - 1 \leq N$  holds in this example.

$$L^2() = \begin{bmatrix} \nabla_{x^2} U^2(x^2, a^2, A^2) - \lambda^2 q \\ U^2(x^2, a^2, A^2) - u^2 \\ \nabla_{x^3} U^3(x^3, a^3, A^3) - \lambda^3 q \\ U^3(x^3, a^3, A^3) - u^3 \\ q^T x^2 - R - \sum_{i \neq 0} \theta_i^2 p^T y^i - q^T e^2 \\ q^T x^3 - R - \sum_{i \neq 0} \theta_i^3 p^T y^i - q^T e^3 \end{bmatrix}, \quad (\text{A.12})$$

and for  $i = 1, 2$ ,

$$L^{2+i}() = \begin{bmatrix} \nabla_{y^i} F^i(y^i, b_0^i, b^i, B^i) - \gamma^i p \\ F^i(y^i, b_0^i, b^i, B^i) \end{bmatrix}. \quad (\text{A.13})$$

We now prove that  $\nabla_{n_t} L^t$  are full-row ranked for all  $t = 1, \dots, 4$ .

$$\nabla_{n_1} L^1 = \begin{bmatrix} \nabla_{x_1^1, x_1^1}^2 U^1 & \nabla_{x_1^1, x_2^1}^2 U^1 & -q_1 & 0 & 0 \\ \nabla_{x_1^1, x_2^1}^2 U^1 & \nabla_{x_2^1, x_2^1}^2 U^1 & -q_2 & 0 & 0 \\ q_1 & q_2 & 0 & 0 & 0 \\ 0 & 0 & 0 & \nabla_{y_1^0} F^0 & \nabla_{y_2^0} F^0 \\ 1 & 0 & 0 & -1 & 0 \\ 0 & 1 & 0 & 0 & -1 \end{bmatrix}. \quad (\text{A.14})$$

Consider the matrix of perturbations

$$Z^1 = \begin{bmatrix} \dot{x}_1^{11} & \dot{x}_1^{12} & \dot{x}_1^{1\lambda} & \frac{1}{\nabla_{y_1^0} F^0} & 0 & 0 \\ \dot{x}_2^{11} & \dot{x}_2^{12} & \dot{x}_2^{1\lambda} & 0 & 0 & 0 \\ \dot{\lambda}_\lambda^{11} & \dot{\lambda}_\lambda^{12} & \dot{\lambda}_\lambda^{1\lambda} & 0 & 0 & 0 \\ 0 & 0 & 0 & \frac{1}{\nabla_{y_1^0} F^0} & -1 & 0 \\ 0 & 0 & 0 & 0 & 0 & -1 \end{bmatrix}. \quad (\text{A.15})$$

$$\nabla_{n_1} L^1 Z^1 = \begin{bmatrix} 1 & 0 & 0 & \frac{\nabla_{x_1^1, x_1^1}^2 U^1}{\nabla_{y_1^0} F^0} & 0 & 0 \\ 0 & 1 & 0 & \frac{\nabla_{x_1^1, x_2^1}^2 U^1}{\nabla_{y_1^0} F^0} & 0 & 0 \\ 0 & 0 & 1 & \frac{q_1}{\nabla_{y_1^0} F^0} & 0 & 0 \\ 0 & 0 & 0 & 1 & -\nabla_{y_1^0} F^0 & -\nabla_{y_2^0} F^0 \\ \dot{x}_1^{11} & \dot{x}_1^{12} & 0 & 0 & 1 & 0 \\ \dot{x}_2^{11} & \dot{x}_2^{12} & 0 & 0 & 0 & 1 \end{bmatrix}. \quad (\text{A.16})$$

If the first condition of (4.8) holds then, by performing elementary row and column operations,  $\nabla_{n_1} L^1 Z^1$  can be converted into an identity matrix. Thus,  $\nabla_{n_1} L^1 Z^1$  is non-singular. Hence,  $\nabla_{n_1} L^1$  is full-row ranked.

$$\nabla_{n_2} L^2 = \begin{bmatrix} \nabla_{x_1^2, x_1^2}^2 U^2 & \nabla_{x_1^2, x_2^2}^2 U^2 & -q_1 & 0 & 0 & 0 & -\lambda^2 & 0 \\ \nabla_{x_1^2, x_2^2}^2 U^2 & \nabla_{x_2^2, x_2^2}^2 U^2 & -q_2 & 0 & 0 & 0 & 0 & -\lambda^2 \\ \nabla_{x_1^2} U^2 & \nabla_{x_2^2} U^2 & 0 & 0 & 0 & 0 & 0 & 0 \\ 0 & 0 & 0 & \nabla_{x_1^3, x_1^3}^2 U^3 & \nabla_{x_1^3, x_2^3}^2 U^3 & -q_1 & -\lambda^3 & 0 \\ 0 & 0 & 0 & \nabla_{x_1^3, x_2^3}^2 U^3 & \nabla_{x_2^3, x_2^3}^2 U^3 & -q_2 & 0 & -\lambda^3 \\ 0 & 0 & 0 & \nabla_{x_1^3} U^3 & \nabla_{x_2^3} U^3 & 0 & 0 & 0 \\ q_1 & q_2 & 0 & 0 & 0 & 0 & x_1^2 - e_1^2 & x_2^2 - e_2^2 \\ 0 & 0 & 0 & q_1 & q_2 & 0 & x_1^3 - e_1^3 & x_2^3 - e_2^3 \end{bmatrix}. \quad (\text{A.17})$$

Consider a matrix of perturbations

$$Z^2 = \begin{bmatrix} \dot{x}_1^{21} & \dot{x}_1^{22} & \dot{x}_1^{2\lambda} & 0 & 0 & 0 & 0 & 0 \\ \dot{x}_2^{21} & \dot{x}_2^{22} & \dot{x}_2^{2\lambda} & 0 & 0 & 0 & 0 & 0 \\ \dot{\lambda}_\lambda^{21} & \dot{\lambda}_\lambda^{22} & \dot{\lambda}_\lambda^{2\lambda} & 0 & 0 & 0 & 0 & 0 \\ 0 & 0 & 0 & \dot{x}_1^{31} & \dot{x}_1^{32} & \dot{x}_1^{3\lambda} & 0 & 0 \\ 0 & 0 & 0 & \dot{x}_2^{31} & \dot{x}_2^{32} & \dot{x}_2^{3\lambda} & 0 & 0 \\ 0 & 0 & 0 & \dot{\lambda}_\lambda^{31} & \dot{\lambda}_\lambda^{32} & \dot{\lambda}_\lambda^{3\lambda} & 1 & 0 \\ 0 & 0 & 0 & 0 & 0 & 0 & 0 & 1 \end{bmatrix}. \quad (\text{A.18})$$

$$\nabla_{n_2} L^2 Z^2 = \begin{bmatrix} 1 & 0 & 0 & 0 & 0 & 0 & 0 & -\lambda^2 & 0 \\ 0 & 1 & 0 & 0 & 0 & 0 & 0 & 0 & -\lambda^2 \\ 0 & 0 & 1 & 0 & 0 & 0 & 0 & 0 & 0 \\ 0 & 0 & 0 & 1 & 0 & 0 & 0 & -\lambda^3 & 0 \\ 0 & 0 & 0 & 0 & 0 & 1 & 0 & 0 & -\lambda^3 \\ 0 & 0 & 0 & 0 & 0 & 0 & 1 & 0 & 0 \\ \sum_{k=1}^2 q_k \dot{x}_k^{21} & \sum_{k=1}^2 q_k \dot{x}_k^{22} & 1 & 0 & 0 & 0 & 0 & x_1^2 - e_1^2 & x_2^2 - e_2^2 \\ 0 & 0 & 0 & \sum_{k=1}^2 q_k \dot{x}_k^{31} & \sum_{k=1}^2 q_k \dot{x}_k^{32} & 1 & x_1^3 - e_1^3 & x_2^3 - e_2^3 \end{bmatrix}. \quad (\text{A.19})$$

Note that  $\sum_{k=1}^2 q_k \dot{x}_k^{hk'} = 0$  for  $h = 2, 3$  and  $k' = 1, 2$ . So

$$\nabla_{n_2} L^2 Z^2 = \begin{bmatrix} 1 & 0 & 0 & 0 & 0 & 0 & -\lambda^2 & 0 \\ 0 & 1 & 0 & 0 & 0 & 0 & 0 & -\lambda^2 \\ 0 & 0 & 1 & 0 & 0 & 0 & 0 & 0 \\ 0 & 0 & 0 & 1 & 0 & 0 & -\lambda^3 & 0 \\ 0 & 0 & 0 & 0 & 1 & 0 & 0 & -\lambda^3 \\ 0 & 0 & 0 & 0 & 0 & 1 & 0 & 0 \\ 0 & 0 & 1 & 0 & 0 & 0 & x_1^2 - e_1^2 & x_2^2 - e_2^2 \\ 0 & 0 & 0 & 0 & 0 & 1 & x_1^3 - e_1^3 & x_2^3 - e_2^3 \end{bmatrix}. \quad (\text{A.20})$$

By elementary row and column operations,  $\nabla_{n_2} L^2 Z^2$  can be converted into

$$\begin{bmatrix} 1 & 0 & 0 & 0 & 0 & 0 & 0 & 0 \\ 0 & 1 & 0 & 0 & 0 & 0 & 0 & 0 \\ 0 & 0 & 1 & 0 & 0 & 0 & 0 & 0 \\ 0 & 0 & 0 & 1 & 0 & 0 & 0 & 0 \\ 0 & 0 & 0 & 0 & 1 & 0 & 0 & 0 \\ 0 & 0 & 0 & 0 & 0 & 1 & 0 & 0 \\ 0 & 0 & 0 & 0 & 0 & 0 & x_1^2 - e_1^2 & x_2^2 - e_2^2 \\ 0 & 0 & 0 & 0 & 0 & 0 & x_1^3 - e_1^3 & x_2^3 - e_2^3 \end{bmatrix}. \quad (\text{A.21})$$

It is clear that if the second condition in (4.8) holds then  $\nabla_{n_2} L^2 Z^2$  can be converted into an identity matrix and hence  $\nabla_{n_2} L^2$  is full-row ranked. For  $i = 1, 2$ ,

$$\nabla_{n_2+i} L^{2+i} = \begin{bmatrix} \nabla_{y_1^i, y_1^i}^2 F^i & \nabla_{y_1^i, y_2^i}^2 F^i & -p_1 \\ \nabla_{y_1^i, y_2^i}^2 F^i & \nabla_{y_2^i, y_2^i}^2 F^i & -p_2 \\ \nabla_{y_1^i} F^i & \nabla_{y_2^i} F^i & 0 \end{bmatrix}. \quad (\text{A.22})$$

The matrix of perturbations  $\dot{\mathbf{Y}}^i$  ensures that  $\nabla_{n_2+i} L^{2+i}$  is full-row ranked for  $i = 1, 2$ . Note that  $\nabla_{\mathbf{n}_{t-1}} L^t = 0$  for all  $t = 2, 3, 4$ . Thus all the conditions of Lemma FRR are satisfied and conclusions of this lemma follow. Hence,  $\nabla \bar{\mathbf{G}}$  is full-row ranked whenever  $\bar{\mathbf{G}}(c, u^2, \dots, u^H, r) = 0$ . Hence,  $\bar{\mathbf{G}} \pitchfork 0$ .

*Step 2:* We show that  $\nabla \bar{\mathbf{G}}_{r, u^2, \dots, u^H} \pitchfork 0$  for all  $\langle r, u^2, \dots, u^H \rangle \in \mathcal{R} \times \mathbf{R}^{H-1}$ .

Note that our computations above show that  $\nabla \bar{\mathbf{G}} = [\nabla_c \bar{\mathbf{G}} \quad \nabla_{r, u^2, \dots, u^H} \bar{\mathbf{G}}]$  is full-row ranked whenever  $\bar{\mathbf{G}}(c, u^2, \dots, u^H, r) = 0$  precisely because  $\nabla_c \bar{\mathbf{G}}$  is full-row ranked. (Recall, no perturbations in  $r, u^2, \dots, u^H$  were used to prove that  $\nabla \bar{\mathbf{G}}$  is full-row ranked.)

Pick  $\langle r, u^2, \dots, u^H \rangle \in \mathcal{R} \times \mathbf{R}^{H-1}$ . Since  $\bar{\mathbf{G}} \pitchfork 0$  and  $\nabla_c \bar{\mathbf{G}}(r, u^2, \dots, u^H, c)$  is full-row ranked for all  $c \in \mathcal{C}$  such that  $\bar{\mathbf{G}}(r, u^2, \dots, u^H, c) = 0$ , the definition of the function  $\bar{\mathbf{G}}_{r, u^2, \dots, u^H}$  implies that

$$\nabla_c \bar{\mathbf{G}}_{r, u^2, \dots, u^H}(c) \equiv \nabla_c \bar{\mathbf{G}}(r, u^2, \dots, u^H, c) \quad (\text{A.23})$$

is full row ranked whenever

$$\bar{\mathbf{G}}_{r, u^2, \dots, u^H}(c) \equiv \bar{\mathbf{G}}(r, u^2, \dots, u^H, c) = 0. \quad (\text{A.24})$$

Hence,  $\bar{\mathbf{G}}_{r, u^2, \dots, u^H} \pitchfork 0$ . ■

**Proof of Theorem CQ:** Let  $\langle \bar{r}, \bar{u}^2, \dots, \bar{u}^H \rangle \in \mathcal{P}$ . We show that there exists an open set in  $\mathcal{R} \times \mathbf{R}^{H-1}$  that contains  $\langle \bar{r}, \bar{u}^2, \dots, \bar{u}^H \rangle$  and is a subset of  $\mathcal{P}$ .  $\langle \bar{r}, \bar{u}^2, \dots, \bar{u}^H \rangle \in \mathcal{P}$  implies that there exists  $\bar{c} \in T(\bar{r})$  such that  $\bar{u}^h = U^h(\bar{x}^h, \bar{a}^h, \bar{A}^h)$  for all  $h = 2, \dots, H$ .<sup>54</sup> This implies that  $\bar{\mathbf{G}}(\bar{c}, \bar{r}, \bar{u}^2, \dots, \bar{u}^H) = 0$ . From Lemma CQ, this implies that  $\nabla \bar{\mathbf{G}}_{\bar{r}, \bar{u}^2, \dots, \bar{u}^H}(\bar{c})$ ,

<sup>54</sup>  $\bar{x}^h$  is the  $x^{h^{th}}$  component of  $\bar{c}$ .

which is a matrix with  $n^c$  columns and  $H + HN + I + IN + N + H$  rows, is full-row ranked. Let  $C = \{(x^h, \lambda^h), (y^i), (\gamma^i)_{i \neq 0}, \hat{p}, q, R\}$ . Since,  $\nabla \bar{\mathbf{G}}_{\bar{r}, \bar{u}^2, \dots, \bar{u}^H}(\bar{c})$  is full-row ranked, there exists a  $H + HN + I + IN + N + H$  dimensional subset  $C_1$  of  $C$  such that  $\nabla_{C_1} \bar{\mathbf{G}}_{\bar{r}, \bar{u}^2, \dots, \bar{u}^H}(\bar{c})$  is full-row ranked. In an obvious way we rewrite  $\bar{c} = \langle \bar{c}_1, \bar{c}_2 \rangle$ . Note  $\bar{c}_2$  lies in  $n_c - (H + HN + I + IN + N + H) = 2N - H$ -dimensional Euclidean space. Under the maintained assumptions,  $2N - H \geq 0$ .<sup>55</sup> Then  $\nabla_{C_1} \bar{\mathbf{G}}(\bar{r}, \bar{u}^2, \dots, \bar{u}^H, \bar{c})$  is full-row ranked and an application of the implicit function theorem implies that there exist open neighborhoods  $O$  and  $V$  around  $\langle \bar{c}_2, \bar{r}, \bar{u}^2, \dots, \bar{u}^H \rangle$  in  $\mathbf{R}^{2N-H} \times \mathcal{R}$  and  $\bar{c}_1$  in  $\mathbf{R}^{H+HN+I+IN+N+H}$ , respectively, and a smooth mapping  $\Psi : O \rightarrow V$  such that  $\bar{\mathbf{G}}(\Psi(r, u^2, \dots, u^H, c_2), r, u^2, \dots, u^H, c_2) = 0$  for all  $\langle r, u^2, \dots, u^H, c_2 \rangle \in O$ . Let  $O'$  be the projection of  $O$  into  $\mathcal{R} \times \mathbf{R}^{H-1}$ . Since  $O$  is open in  $\mathbf{R}^{2N-1} \times \mathcal{R}$ , we have  $O'$  open in  $\mathcal{R} \times \mathbf{R}^{H-1}$ . Clearly,  $O'$  contains  $\langle \bar{r}, \bar{u}^2, \dots, \bar{u}^H \rangle$  and is a subset of  $\mathcal{P}$ . ■

### Proof of Theorem SB:

*Proof of (i):* Pick  $r \in \mathcal{R}$ . Under Assumption SB1 (a),  $\Gamma(r) \neq \emptyset$ . Pick  $\langle \bar{c}, \bar{l}, \bar{u}^2, \dots, \bar{u}^H \rangle \in \Gamma(r) \subset \mathbf{R}^{H-1} \times \mathcal{C} \times \mathbf{R}^{n_l}$ . We show that there exists an open set  $Z$  in  $\mathbf{R}^{H-1} \times \mathcal{C} \times \mathbf{R}^{n_l}$  such that  $\langle \bar{c}, \bar{l}, \bar{u}^2, \dots, \bar{u}^H \rangle \in Z$  and  $Z \cap \Gamma(r)$  is homeomorphic to an open set in  $\mathbf{R}^{H-1}$ .

$\langle \bar{c}, \bar{l}, \bar{u}^2, \dots, \bar{u}^H \rangle \in \Gamma(r)$  implies that  $\langle \bar{c}, \bar{l} \rangle \in \Phi_r(\bar{u}^2, \dots, \bar{u}^H)$ . Define  $V_{\bar{u}^2, \dots, \bar{u}^H}(r)$ ,  $O_{\bar{u}^2, \dots, \bar{u}^H}^j(r)$ , and  $\mathbf{g}_{\mathbf{r}, \bar{u}^2, \dots, \bar{u}^H}^j$  for all  $j \in J$  as in Assumption SB1. Then it follows that there exists  $j \in J$  such that  $\mathbf{g}_{\mathbf{r}, \bar{u}^2, \dots, \bar{u}^H}^j(\bar{u}^2, \dots, \bar{u}^H) = \langle \bar{c}, \bar{l} \rangle \in O_{\bar{u}^2, \dots, \bar{u}^H}^j(r)$ . Choose  $Z = V_{\bar{u}^2, \dots, \bar{u}^H}(r) \times O_{\bar{u}^2, \dots, \bar{u}^H}^j(r)$ . Then  $\langle \bar{c}, \bar{l}, \bar{u}^2, \dots, \bar{u}^H \rangle \in Z$  and, as a Cartesian product of two open sets,  $Z$  is open in  $\mathbf{R}^{H-1} \times \mathcal{C} \times \mathbf{R}^{n_l}$ . Under Assumption SB1 (b),  $O_{\bar{u}^2, \dots, \bar{u}^H}^j(r) \cap O_{\bar{u}^2, \dots, \bar{u}^H}^{j'}(r) = \emptyset$  for all  $j' \in J$  such that  $j' \neq j$ . Hence,  $\Gamma(r) \cap Z = Gr(\mathbf{g}_{\mathbf{r}, \bar{u}^2, \dots, \bar{u}^H}^j)$ .<sup>56</sup>  $Z$  open in  $\mathbf{R}^{H-1} \times \mathcal{C} \times \mathbf{R}^{n_l}$  and  $\Gamma(r) \subset \mathbf{R}^{H-1} \times \mathcal{C} \times \mathbf{R}^{n_l}$  implies that  $Z \cap \Gamma(r)$  is open in  $\Gamma(r)$ .

Define the mapping  $\Psi : Z \cap \Gamma(r) \rightarrow \Psi(Z \cap \Gamma(r))$  with image  $\Psi(c, l, u^2, \dots, u^H) \equiv \Psi(\mathbf{g}_{\mathbf{r}, \bar{u}^2, \dots, \bar{u}^H}^j(u^2, \dots, u^H), u^2, \dots, u^H) = \langle u^2, \dots, u^H \rangle$ .  $\Psi$  is clearly a homeomorphism. We show that  $\Psi(Z \cap \Gamma(r))$  is open in  $\mathbf{R}^{H-1}$ . This is true as  $\Psi(Z \cap \Gamma(r)) = V_{\bar{u}^2, \dots, \bar{u}^H}(r)$  and  $V_{\bar{u}^2, \dots, \bar{u}^H}(r)$  is a set open in  $\mathcal{P}(r)$  and  $\mathcal{P}(r)$  is open in  $\mathbf{R}^{H-1}$  (this follows from the Corollary CQ). This proves that  $\Gamma(r)$  is a  $H - 1$ -dimensional manifold.

We now show that  $U(r)$  is a  $H - 1$ -dimensional manifold. Remark SB implies that  $U(r)$  is not empty. Let  $\langle \bar{u}^1, \dots, \bar{u}^H \rangle \in U(r)$ . We show that there exists an open set  $\mathbf{V}$  in  $\mathbf{R}^H$  such that  $\langle \bar{u}^1, \dots, \bar{u}^H \rangle \in \mathbf{V}$  and  $\mathbf{V} \cap U(r)$  is homeomorphic to an open set in  $\mathbf{R}^{H-1}$ .

Since  $\Phi_r^*(\bar{u}^2, \dots, \bar{u}^H) \subseteq \Phi_r(\bar{u}^2, \dots, \bar{u}^H)$  and since Assumption SB1 holds, there exists  $J_{\bar{u}^2, \dots, \bar{u}^H}^* \subset J$  such that  $\Phi_r^*(\bar{u}^2, \dots, \bar{u}^H) = \{\mathbf{g}_{\mathbf{r}, \bar{u}^2, \dots, \bar{u}^H}^j(\bar{u}^2, \dots, \bar{u}^H)\}_{j \in J_{\bar{u}^2, \dots, \bar{u}^H}^*}$ .

<sup>55</sup> Our maintained assumptions include  $H - 1 \leq N$  and  $N \geq 1$ .

<sup>56</sup> For any mapping  $f : A \rightarrow B$ ,  $Gr(f)$  is the graph of  $f$  in  $A \times B$ .

For all  $j \in J$  define the functions  $\mathcal{V}_r^j : V_{\bar{u}^2, \dots, \bar{u}^H}(r) \rightarrow \mathbf{R}$  with image  $\mathcal{V}_r^j(u^2, \dots, u^H) = U^1(x^{1j}(u^2, \dots, u^H), a^1, A^1)$ .<sup>57</sup> The continuity of the mappings  $U^1$  and  $\mathbf{g}_{\mathbf{r}, \bar{u}^2, \dots, \bar{u}^H}^j$  imply that  $\mathcal{V}_r^j$  is continuous for all  $j \in J$ . Further,  $\mathcal{V}_r^j(\bar{u}^2, \dots, \bar{u}^H) = \mathcal{V}_r^{j'}(\bar{u}^2, \dots, \bar{u}^H)$  for all  $j, j' \in \mathcal{J}_{\bar{u}^2, \dots, \bar{u}^H}^*(r)$  and  $\mathcal{V}_r^j(\bar{u}^2, \dots, \bar{u}^H) > \mathcal{V}_r^{j'}(\bar{u}^2, \dots, \bar{u}^H)$  for all  $j' \notin \mathcal{J}_{\bar{u}^2, \dots, \bar{u}^H}^*(r)$  and  $j \in \mathcal{J}_{\bar{u}^2, \dots, \bar{u}^H}^*(r)$ . The continuity of the functions  $\mathcal{V}_r^j$  implies that there exists  $V'_{\bar{u}^2, \dots, \bar{u}^H}(r)$  open in  $V_{\bar{u}^2, \dots, \bar{u}^H}(r)$  such that for all  $j \in \mathcal{J}_{\bar{u}^2, \dots, \bar{u}^H}^*(r)$ ,  $j' \notin \mathcal{J}_{\bar{u}^2, \dots, \bar{u}^H}^*(r)$ , and  $\langle u^2, \dots, u^H \rangle \in V'_{\bar{u}^2, \dots, \bar{u}^H}(r)$  we have  $\mathcal{V}_r^j(u^2, \dots, u^H) > \mathcal{V}_r^{j'}(u^2, \dots, u^H)$ . In that case, for all  $\langle u^2, \dots, u^H \rangle \in V'_{\bar{u}^2, \dots, \bar{u}^H}(r)$ , the value function  $\mathcal{V}$  of Problem (4.1) is

$$\mathcal{V}(u^2, \dots, u^H, r) = \max_{j \in \mathcal{J}_{\bar{u}^2, \dots, \bar{u}^H}^*(r)} \mathcal{V}_r^j(u^2, \dots, u^H). \quad (\text{A.25})$$

Hence, as a maximum of continuous functions, the mapping  $\mathcal{V}$  restricted to  $V'_{\bar{u}^2, \dots, \bar{u}^H}(r)$  is continuous. Define a mapping  $\rho : V'_{\bar{u}^2, \dots, \bar{u}^H}(r) \rightarrow \rho(V'_{\bar{u}^2, \dots, \bar{u}^H}(r))$  with image  $\rho(u^2, \dots, u^H) = \langle u^2, \dots, u^H, \mathcal{V}(u^2, \dots, u^H, r) \rangle$ .  $\rho$  is a homeomorphism.  $V'_{\bar{u}^2, \dots, \bar{u}^H}(r)$  is open in  $\mathbf{R}^{H-1}$  as  $V_{\bar{u}^2, \dots, \bar{u}^H}(r)$  is open in  $\mathbf{R}^{H-1}$  and  $V'_{\bar{u}^2, \dots, \bar{u}^H}(r) \subset V_{\bar{u}^2, \dots, \bar{u}^H}(r)$ . We prove that  $\rho(V'_{\bar{u}^2, \dots, \bar{u}^H}(r))$  is open in  $U(r)$ . Consider any open set  $\mathbf{V}$  in  $\mathbf{R}^H$  such that projection of  $\mathbf{V}$  into  $\mathbf{R}^{H-1}$  is  $V'_{\bar{u}^2, \dots, \bar{u}^H}(r)$ . Then it is clear that  $\rho(V'_{\bar{u}^2, \dots, \bar{u}^H}(r)) = \mathbf{V} \cap U(r)$ . Hence  $\rho(V'_{\bar{u}^2, \dots, \bar{u}^H}(r))$  is open in  $U(r)$  and is a  $H - 1$ -dimensional manifold.

*Proof of (ii):* Let  $\langle \bar{u}^2, \dots, \bar{u}^H \rangle \in \mathcal{P}(r)$ . Remark SB implies that  $\mathcal{F}_r^*(\bar{u}^2, \dots, \bar{u}^H)$  is not empty. For all  $j \in J$  define the mapping  $\mathcal{V}_r^j$  and the set  $V'_{\bar{u}^2, \dots, \bar{u}^H}(r)$  as in the proof of part (i) above. We show that, under Assumption SB2,  $\mathcal{V}_r^j(u^2, \dots, u^H) = \mathcal{V}(u^2, \dots, u^H, r)$  for all  $j \in \mathcal{J}_{\bar{u}^2, \dots, \bar{u}^H}^*(r)$  and all  $\langle u^2, \dots, u^H \rangle \in V'_{\bar{u}^2, \dots, \bar{u}^H}(r)$ . (This would imply (A.5) if we choose  $\hat{V}_{\bar{u}^2, \dots, \bar{u}^H}(r)$  to be equal to  $V'_{\bar{u}^2, \dots, \bar{u}^H}(r)$ .) Suppose not. Then there exists  $\tilde{j} \in \mathcal{J}_{\bar{u}^2, \dots, \bar{u}^H}^*(r)$  and  $\langle \tilde{u}^2, \dots, \tilde{u}^H \rangle \in V'_{\bar{u}^2, \dots, \bar{u}^H}(r)$  such that  $\mathcal{V}_r^{\tilde{j}}(\tilde{u}^2, \dots, \tilde{u}^H) < \mathcal{V}(\tilde{u}^2, \dots, \tilde{u}^H, r)$ . On the other hand, we know that  $\mathcal{V}_r^j(\bar{u}^2, \dots, \bar{u}^H) = \mathcal{V}(\bar{u}^2, \dots, \bar{u}^H, r)$  for all  $j \in \mathcal{J}_{\bar{u}^2, \dots, \bar{u}^H}^*(r)$ . Consider the line joining  $\bar{u}_{-1} := \langle \bar{u}^2, \dots, \bar{u}^H \rangle$  and  $\tilde{u}_{-1} := \langle \tilde{u}^2, \dots, \tilde{u}^H \rangle$  with parameterised equation  $u_{-1}(t) = (\tilde{u}_{-1} - \bar{u}_{-1})t + \bar{u}_{-1}$ , where  $t$  is a scalar. Thus,  $u_{-1}(0) = \bar{u}_{-1}$  and  $u_{-1}(1) = \tilde{u}_{-1}$ . Define

$$\tilde{t} := \max\{t \in [0, 1] \mid \mathcal{V}_r^{\tilde{j}}(u(t)_{-1}) - \mathcal{V}(u(t)_{-1}, r) = 0 \text{ and } \mathcal{V}_r^{\tilde{j}}(u(t')_{-1}) - \mathcal{V}(u(t')_{-1}, r) = 0 \forall t' < t\}. \quad (\text{A.26})$$

<sup>57</sup> Note,  $x^{1j}(u^2, \dots, u^H)$  is the  $x^{1th}$  component of  $\langle c, l \rangle = \mathbf{g}_{\mathbf{r}, \bar{u}^2, \dots, \bar{u}^H}^j(u^2, \dots, u^H)$  and  $a^1$  and  $A^1$  are the respective components of  $r$ . Thus,  $\mathcal{V}_r^j(u^2, \dots, u^H)$  is the value of the objective function of Problem (4.1) evaluated at the stationary point  $\mathbf{g}_{\mathbf{r}, \bar{u}^2, \dots, \bar{u}^H}^j(u^2, \dots, u^H)$ .



Define  $\tilde{u}_{-1}^* = u(\tilde{t}^*)_{-1}$  and  $\langle \tilde{c}^*, \tilde{l}^* \rangle = \mathbf{g}_{\mathbf{r}, \bar{\mathbf{u}}^2, \dots, \bar{\mathbf{u}}^H}^{\tilde{j}}(\tilde{u}_{-1}^*)$ . Note that  $\langle \tilde{c}^*, \tilde{l}^* \rangle \in \tilde{\Phi}_r^*(\tilde{u}_{-1}^*)$ . The continuity of the mappings  $\mathcal{V}_r^{\tilde{j}}$  and  $\mathcal{V}$  restricted to  $V'_{\tilde{u}^2, \dots, \tilde{u}^H}(r)$  (see proof of Part (i) above) imply that there exists  $\epsilon > 0$  such that for all  $t \in (\tilde{t}^*, \tilde{t}^* + \epsilon)$ , we have  $\mathcal{V}_r^{\tilde{j}}(u(t)_{-1}) - \mathcal{V}(u(t)_{-1}, r) < 0$ . Let  $\{t^v\} \rightarrow \tilde{t}^*$  with  $t^v > \tilde{t}^*$  for all  $v$ . Then for all sequences  $\{\langle c^v, l^v \rangle\}$  such that  $\langle c^v, l^v \rangle \in \tilde{\Phi}_r^*(u(t^v)_{-1})$  for all  $v$ , we have  $\{\langle c^v, l^v \rangle\}$  does not converge to  $\langle \tilde{c}^*, \tilde{l}^* \rangle$ . This is because (1) for all big enough  $v$  (that is, for  $t^v \in (\tilde{t}^*, \tilde{t}^* + \epsilon)$ ), we have  $\langle c^v, l^v \rangle \neq \mathbf{g}_{\mathbf{r}, \bar{\mathbf{u}}^2, \dots, \bar{\mathbf{u}}^H}^{\tilde{j}}(u(t^v)_{-1})$  and (2) under Assumption SB1, the range of mapping  $\mathbf{g}_{\mathbf{r}, \bar{\mathbf{u}}^2, \dots, \bar{\mathbf{u}}^H}^{\tilde{j}}$  is disjoint from the range of all other mappings  $\mathbf{g}_{\mathbf{r}, \bar{\mathbf{u}}^2, \dots, \bar{\mathbf{u}}^H}^j$  such that  $j \neq \tilde{j}$ . But this implies that  $\tilde{\Phi}_r^*$  is not lower-hemi continuous. A contradiction arises.

Choose  $\hat{V}_{\tilde{u}^2, \dots, \tilde{u}^H}(r)$  to be equal to  $V'_{\tilde{u}^2, \dots, \tilde{u}^H}(r)$ . For all  $j \in \tilde{J}_{\tilde{u}^2, \dots, \tilde{u}^H}(r)$ , with an abuse of notation, call the restriction of the mapping  $\mathbf{g}_{\tilde{u}^2, \dots, \tilde{u}^H}^j$  to  $\hat{V}_{\tilde{u}^2, \dots, \tilde{u}^H}(r)$  also as  $\mathbf{g}_{\tilde{u}^2, \dots, \tilde{u}^H}^j$ . For all  $j \in \tilde{J}_{\tilde{u}^2, \dots, \tilde{u}^H}(r)$ , define the mapping  $\Psi^j : Gr(\mathbf{g}_{\tilde{u}^2, \dots, \tilde{u}^H}^j) \rightarrow \mathbf{R}^{H-1}$  with image  $\Psi^j(u^2, \dots, u^H, \mathbf{g}_{\tilde{u}^2, \dots, \tilde{u}^H}^j(u^2, \dots, u^H)) = \langle u^2, \dots, u^H \rangle$  for all  $\langle u^2, \dots, u^H \rangle \in \hat{V}_{\tilde{u}^2, \dots, \tilde{u}^H}(r)$ . Clearly  $\Psi^j$  is a homeomorphism between  $Gr(\mathbf{g}_{\tilde{u}^2, \dots, \tilde{u}^H}^j)$  and  $\hat{V}_{\tilde{u}^2, \dots, \tilde{u}^H}(r)$ . Define the mapping  $\zeta^j = \rho \circ \Psi^j$ , where the mapping  $\rho$  is as defined in the proof of part (i) above. Then  $\zeta^j$  defines the required homeomorphism between  $Gr(\mathbf{g}_{\tilde{u}^2, \dots, \tilde{u}^H}^j)$  and an open set in  $U(r)$  for all  $j \in \tilde{J}$ . ■

### Proof of Lemma SB1:

- (1) This is obvious when one notes that because of the normalization adopted,  $p_1 = 1$ , so that  $\hat{p} - \frac{\hat{\beta}}{\beta_1} = 0$  is equivalent to  $p - \frac{\beta}{\beta_1} = 0$ .
- (2) Suppose  $c$  is a production efficient stationary value of Problem (4.1). Then there exists  $\tau > 0$  such that  $\tau p = \beta$ . The last set of equations in (5.3) implies that, for every  $i \neq 0$ ,  $\nabla_{y^i, y^i} F^i \phi^i = [\mu^i \gamma^i - \sum_h \psi^h \theta_i^h - \tau] p$ . Premultiply both sides by  $\phi^{iT}$ . Then the first set of equations in (5.6) implies that

$$\phi^{iT} \nabla_{y^i, y^i} F^i \phi^i = [\mu^i \gamma^i - \sum_h \psi^h \theta_i^h - \tau] \phi^{iT} p = 0. \quad (\text{A.27})$$

Since  $\nabla_{y^i, y^i} F^i$  is positive definite for every  $i \neq 0$ , (A.27) is true if and only if  $\phi^{iT} = 0$  for every  $i \neq 0$ . Suppose  $\phi^i = 0_N$  for every  $i \neq 0$ . Then production efficiency of  $c$  follows from the last two set of equations in (5.3).

- (3) Suppose  $c$  is not production efficient and there exists  $i \neq 0$  such that  $\phi^i = 0_N$ . Then the last set of equations in (5.3) implies that  $[-\sum_h \psi^h \theta_i^h + \mu^i \gamma^i] p = \beta$ , which is a contradiction to  $c$  not being production efficient. ■

**Proof of Lemma SB2:** Similar to proof of Lemma SB1. ■

**Proof of Lemma SB3:** First we claim that

$$\sum_h \psi^h \sum_{i \neq 0} \theta_i^h y^i + \sum_{i \neq 0} \gamma^i \phi^i = 0 \quad (\text{A.28})$$

This is true because multiplying the  $h^{\text{th}}$  budget equation in (5.7) by  $\psi^h$  and adding over all  $h$  gives

$$\sum_h \psi^h q^T [x^h - e^h] - R \sum_h \psi^h - \sum_h \psi^h \sum_{i \neq 0} \theta_i^h p^T y^i = 0. \quad (\text{A.29})$$

Pre-multiplying the second set of equations in (5.7) by  $q^T$  and employing the last set of equations in (5.7) gives

$$\sum_h \psi^h q^T [x^h - e^h] = 0. \quad (\text{A.30})$$

Employing (A.29), (A.30), and (5.8), we obtain

$$\sum_h \psi^h \sum_{i \neq 0} \theta_i^h p^T y^i = 0. \quad (\text{A.31})$$

Multiplying the first set of equations in (5.6) by  $\gamma^i$ , adding these over all  $i$ , and employing (A.31), we obtain

$$\sum_h \psi^h \sum_{i \neq 0} \theta_i^h p^T y^i + \sum_{i \neq 0} \gamma^i p^T \phi^i = 0 \quad (\text{A.32})$$

Pre-multiplying the second set of equations in (5.6) by  $\hat{p}^T$  we obtain

$$\sum_h \psi^h \sum_{i \neq 0} \theta_i^h \hat{p}^T \hat{y}^i + \sum_{i \neq 0} \gamma^i \hat{p}^T \hat{\phi}^i = 0 \quad (\text{A.33})$$

(A.32) minus (A.33) and noting that  $p_1 = 1$  under our normalization, we obtain

$$\sum_h \psi^h \sum_{i \neq 0} \theta_i^h y_1^i + \sum_{i \neq 0} \gamma^i \phi_1^i = 0 \quad (\text{A.34})$$

The second set of equations in (5.6) and (A.34) imply (A.28).

Now suppose  $\psi^h = 0$  for all  $h$ . Then (A.28) implies

$$\sum_{i \neq 0} \gamma^i \phi^i = 0_N \quad (\text{A.35})$$

The last set of equations in (5.3) implies

$$-\mu^i \gamma^i p - \nabla_{y^i, y^i} F^i \phi^i + \beta = 0, \quad \forall i \neq 0 \quad (\text{A.36})$$

Premultiplying both sides of (A.36) by  $\phi^{iT}$  we obtain

$$-\mu^i \gamma^i \phi^{iT} p - \phi^{iT} \nabla_{y^i, y^i} F^i \phi^i + \phi^{iT} \beta = 0, \quad \forall i \neq 0 \quad (\text{A.37})$$

Employing the first set of equations in (5.6) and multiplying (A.37) by  $\gamma^i$  and adding over all  $i \neq 0$ , we obtain

$$-\sum_{i \neq 0} \gamma^i \phi^{iT} \nabla_{y^i, y^i} F^i \phi^i + \beta \sum_{i \neq 0} \gamma^i \phi^{iT} = 0, \quad (\text{A.38})$$

Since  $\gamma^i > 0$  for all  $i \neq 0$ ,  $\nabla_{y^i, y^i} F^i$  is positive definite, and (A.35) holds, we find that (A.38) is true if and only if  $\phi^i = 0$  for all  $i \neq 0$ . In an exactly similar manner we can prove that  $\kappa^h = 0$  for all  $h$ . Lemmas SB1 and SB2 imply that  $c$  is both consumption and production efficient.

Suppose  $c$  is both a consumption and production efficient tax equilibrium. Lemmas SB1 and SB2 imply that  $\phi^i = 0$  for all  $i \neq 0$  and  $\kappa^h = 0$  for all  $h$ . (5.2) implies that

$$[\alpha^h \lambda^h - \psi^h]_q = \beta, \quad \forall h \quad (\text{A.39})$$

(5.3) implies that

$$\left[ \sum_h \psi^h \theta_i^h - \mu^i \gamma^i \right]_p = -\beta, \quad \forall i \neq 0. \quad (\text{A.40})$$

Given our assumption on the technologies of firms and the preferences of the consumers, the second set of equations in (5.4) imply that  $\beta \gg 0$ . Hence (A.39) and (A.40) imply that  $\alpha^h \lambda^h - \psi^h > 0$  for all  $h$  and  $\sum_h \psi^h \theta_i^h - \mu^i \gamma^i < 0$  for all  $i \neq 0$ . Define  $\bar{\alpha}^h = \frac{\alpha^h \lambda^h - \psi^h}{\lambda^h}$  and  $\bar{\mu}^i = \frac{\sum_h \psi^h \theta_i^h - \mu^i \gamma^i}{\gamma^i}$  for all  $i \neq 0$ . Consider a set of new vector  $\tilde{l}$  of Lagrange multipliers:

1.  $\tilde{\psi}^h = 0$  for all  $h$
2.  $\tilde{\kappa}^h = 0$  for all  $h$
3.  $\tilde{\phi}^i = 0$  for all  $i \neq 0$
4.  $\tilde{\alpha}^h = \frac{\bar{\alpha}^h}{\bar{\alpha}^1}$  for all  $h$
5.  $\tilde{\mu}^i = \frac{\bar{\mu}^i}{\bar{\alpha}^1}$  for all  $i \neq 0$
6.  $\tilde{\delta} = \frac{\delta}{\bar{\alpha}^1}$ , and
7.  $\tilde{\beta} = \frac{\beta}{\bar{\alpha}^1}$ .

Then the new set of multipliers  $\tilde{l} = \langle (\tilde{\alpha}^h), (\tilde{\psi}^h), (\tilde{\kappa}^h), (\tilde{\phi}^i)_{i \neq 0}, \tilde{\delta}, (\tilde{\mu}^i)_{i \neq 0}, \tilde{\beta} \rangle$  along with  $c$  also solve equations (5.2) to (5.9), and hence solve Problem (4.1), *i.e.*,  $\mathbf{\Gamma}(c, \tilde{l}, r, u^2, \dots, u^H) = 0$ . But, since the constraint qualification holds, and the Jacobian matrix of the constraints of Problem (4.1) is full-row ranked, the theorem of Lagrange implies that the vector of Lagrange multipliers is uniquely paired up with the vector of choice variables. Hence,  $l = \tilde{l}$ . Hence,  $\psi^h = \tilde{\psi}^h = 0$  for all  $h$ . ■

**Proof of Lemma SB4:** For all  $h$ ,  $Cl(\mathcal{X}^h)$  is compact and, for all  $i$ ,  $\mathcal{Y}^i \cap Cl(N_{\epsilon'}(\bar{y}^i))$  is compact.<sup>58</sup> This implies that, for all  $\langle c, l \rangle \in \mathbf{S}$ ,  $\langle (x^h), (y^i) \rangle$  lies in a compact set. At a tax equilibrium, we have  $p = \gamma^i \nabla_{y^i} F^i$  for all  $i \neq 0$ . Further,  $p_1 = 1$  implies that, at a

<sup>58</sup> For any set  $A \subset \mathbf{R}^N$ ,  $Cl(A)$  is the closure of  $A$  in  $\mathbf{R}^N$ .

tax equilibrium,  $\gamma^i = \frac{1}{\nabla_{y_1^i} F^i}$  for all  $i \neq 0$ . From continuity of  $\nabla_{y^i} F^i$  in  $y^i$  over a compact domain  $\mathcal{Y}^i \cap Cl(N_{e'}(\bar{y}^i))$ , it follows that, for all  $\langle c, l \rangle \in \mathbf{S}$ , we have  $\langle (\gamma^i)_{i \neq 0}, p \rangle$  lies in a compact set. Continuity of  $\nabla_{x^h} U^h$  in  $x^h$  over a compact domain  $Cl(\mathcal{X}^h)$  implies that, for all  $\langle c, l \rangle \in \mathbf{S}$ , we have  $\lambda^h q$  lies in a compact set for all  $h$ . It follows that, for all  $\langle c, l \rangle \in \mathbf{S}$ , we have  $\langle (\lambda^h), q \rangle$  lies in a compact set. From the consumer budget constraint at a tax equilibrium, it follows that  $HR = q \sum_h [x^h - e^h] - \sum_i p y^i$ . From the above arguments and the boundedness of  $(e^h)$  (which follows from the boundedness of  $\mathcal{R}$  in our definition of the class of economies  $\mathcal{E}$ ), all terms on the right-side of this equality lie in compact sets, so for all  $\langle c, l \rangle \in \mathbf{S}$ ,  $R$  lies in a compact set. The Lagrange multipliers are obtained at the optimum by first taking the derivatives of the objective function  $U^1()$  with respect to the choice variables and then the derivatives of the choice variables with respect to the parameters of Problem (4.1). Since these derivatives are continuous and bounded<sup>59</sup> the vector of Lagrange multipliers  $l$  also lies in a compact set whenever  $\langle c, l \rangle \in \mathbf{S}$ . So  $\mathbf{S}$  lies in a compact set. Noting that (1) for all  $h$ ,  $Cl(\mathcal{X}^h)$  is compact, (2) the set  $\mathcal{U}^h$  consists of continuous functions which are obtained by perturbing  $u^h$  in its first and second order derivatives, and (3)  $\mathcal{R}$  is bounded, it is clear that the utility profiles  $\langle u^2, \dots, u^H \rangle$  that can be attained in  $\prod_h \mathcal{X}^h$  are bounded. Hence,  $\mathbf{S}'$  also lies in a compact set. ■

To prove Lemma SBPCI, we first prove Lemmas SBPCI.i to SBPCI.viii below by employing Lemma FRR.

**Lemma SBPCI.i:**  $\tilde{\Gamma}_x^h \pitchfork 0$ .

**Proof:** For every  $h$ ,  $U^h(x^h, a^h, A^h) = u^h(x^h) + a^{hT} x^h + x^{hT} A^h x^h$ . This implies that

$$\begin{aligned} \nabla_{x^h} U^h() &= \nabla_{x^h} u^h(x^h) + a^h + A^h x^h \text{ and} \\ \nabla_{x^h, x^h} U^h() &= \nabla_{x^h, x^h} u^h(x^h) + A^h, \end{aligned} \tag{A.41}$$

where<sup>60</sup>

$$A^h = \begin{bmatrix} a_{1,1}^h & a_{1,2}^h & a_{1,3}^h & \dots & a_{1,N}^h \\ a_{1,2}^h & a_{2,2}^h & a_{2,3}^h & \dots & a_{2,N}^h \\ a_{1,3}^h & a_{2,3}^h & a_{3,3}^h & \dots & a_{3,N}^h \\ \vdots & \vdots & \vdots & \ddots & \vdots \\ a_{1,N}^h & a_{2,N}^h & a_{3,N}^h & \dots & a_{N,N}^h \end{bmatrix} \text{ and } a^h = \begin{bmatrix} a_1^h \\ a_2^h \\ \vdots \\ a_N^h \end{bmatrix}. \tag{A.42}$$

From Lemmas SB1 and SB2 it follows that if  $\tilde{\Gamma}(u^1, \dots, u^H, r, c, l) = 0$  then  $c$  is a production and consumption inefficient tax equilibrium and  $\kappa^h \neq 0$  and  $\phi^i \neq 0$  for all  $h$  and  $i \neq 0$ . Therefore, for every  $h$  there exists  $k_h$  such that  $\kappa_{k_h}^h \neq 0$ . We now apply Lemma

<sup>59</sup> As seen above, the choice variables are bounded due to the compactness of the sets  $Cl(\mathcal{X}^h)$  and  $\mathcal{Y}^i \cap Cl(N_{e'}(\bar{y}^i))$  for all  $h$  and  $i$

<sup>60</sup> Recall,  $A^h$  is a symmetric matrix and hence has  $\frac{N(N+1)}{2}$  elements.

FRR with  $T = 2$ ,  $L^1$  being the first set of equations in  $\tilde{\Gamma}_x^h$ , and  $L^2$  being the second set of equations in  $\tilde{\Gamma}_x^h$ . This implies that  $M_1 = N$  and  $M_2 = N$ .  $n_1 = \{a_1^h, \dots, a_N^h\}$  and  $n_2 = \{a_{1,k_h}^h, \dots, a_{k_h,k_h}^h, a_{k_h,k_h+1}^h, \dots, a_{k_h,N}^h\}$ .

$$\nabla_{n_1} L^1 = \nabla_{a^h, x^h} U^h = \mathcal{I}_N. \quad (\text{A.43})$$

This implies that  $\nabla_{n_1} L^1$  is full-row ranked and hence  $\nabla L^1$  is full-row ranked.

$$\begin{aligned} \nabla_{n_2} L^2 = & \left[ -\nabla_{a_{1,k_h}^h} [A^h \kappa^h] \quad \dots \quad -\nabla_{a_{k_h,k_h}^h} [A^h \kappa^h] \quad -\nabla_{a_{k_h,k_h+1}^h} [A^h \kappa^h] \quad \dots \quad -\nabla_{a_{k_h,k_h+N}^h} [A^h \kappa^h] \right] \\ = & \begin{bmatrix} -\kappa_{k_h}^h & 0 & \dots & 0 & 0 & \dots & 0 \\ 0 & -\kappa_{k_h}^h & \dots & 0 & 0 & \dots & 0 \\ \vdots & \vdots & & & & & \\ -\kappa_1^h & -\kappa_2^h & \dots & -\kappa_{k_h}^h & -\kappa_{k_h+1}^h & \dots & -\kappa_N^h \\ 0 & 0 & \dots & 0 & -\kappa_{k_h}^h & \dots & 0 \\ \vdots & \vdots & & & & & \\ 0 & 0 & \dots & 0 & 0 & \dots & -\kappa_{k_h}^h \end{bmatrix}. \end{aligned} \quad (\text{A.44})$$

By elementary row and column operations, it can be show that  $\nabla_{n_2} L^2$  can be converted into an Identity matrix, and hence is full-row ranked. Further, note that  $\nabla_{n_1} L^2 = 0$ . Hence, the conclusions of Lemma FRR can be employed to show that  $\nabla L$ , which is the same as  $\nabla \tilde{\Gamma}_x^h$ , is full-row ranked. ■

**Lemma SBPCI.ii:**  $\tilde{\Gamma}_y^i \pitchfork 0$ .

**Proof:** For every  $i \neq 0$ ,  $F^i(y^i, b_0^i, b^h, B^h) = b_0^i + f^i(y^i) + b^{iT} y^i + y^{iT} B^i y^i$ . This implies that

$$\begin{aligned} \nabla_{y^i} F^i() &= \nabla_{y^i} f^i(y^i) + b^i + B^i y^i \text{ and} \\ \nabla_{y^i, y^i} F^i() &= \nabla_{y^i, y^i} f^i(y^i) + B^i, \end{aligned} \quad (\text{A.45})$$

where

$$B^i = \begin{bmatrix} b_{1,1}^i & b_{1,2}^i & b_{1,3}^i & \dots & b_{1,N}^i \\ b_{1,2}^i & b_{2,2}^i & b_{2,3}^i & \dots & b_{2,N}^i \\ b_{1,3}^i & b_{2,3}^i & b_{3,3}^i & \dots & b_{3,N}^i \\ \vdots & \vdots & & & \\ b_{1,N}^i & b_{2,N}^i & b_{3,N}^i & \dots & b_{N,N}^i \end{bmatrix} \text{ and } b^i = \begin{bmatrix} b_1^i \\ b_2^i \\ \vdots \\ b_N^i \end{bmatrix} \quad (\text{A.46})$$

From Lemmas SB1 and SB2 it follows that if  $\tilde{\Gamma}(u^1, \dots, u^H, r, c, l) = 0$  then  $c$  is a production and consumption inefficient tax equilibrium and  $\kappa^h \neq 0$  and  $\phi^i \neq 0$  for all  $h$  and  $i \neq 0$ . Therefore, for every  $i \neq 0$  there exists  $k_i$  such that  $\phi_{k_i}^i \neq 0$ . We now apply Lemma FRR with  $T = 3$ ,  $L^1$ ,  $L^2$ , and  $L^3$  being the first, second, and third sets of equations in  $\tilde{\Gamma}_{\mathbf{y}}^i$ . This implies that  $M_1 = 1$ ,  $M_2 = N$ , and  $M_3 = N$ .  $n_1 = \{b_0^i\}$ ,  $n_2 = \{b_1^i, \dots, b_N^i\}$ , and  $n_3 = \{b_{1,k_i}^i, \dots, b_{k_i,k_i}^i, b_{k_i,k_i+1}^i, \dots, b_{k_i,N}^i\}$ . Thus,  $M_1 = 1$ ,  $M_2 = |n_2|$  and  $M_3 = |n_3|$ .

$$\nabla_{n_1} L^1 = \nabla_{b_0^i} F^i = [1]. \quad (\text{A.47})$$

$$\nabla_{n_2} L^2 = \nabla_{b^{i,y^i}} F^i = \mathcal{I}_N. \quad (\text{A.48})$$

This implies that  $\nabla_{n_1} L^1$  and  $\nabla_{n_2} L^2$  are full-row ranked and hence  $\nabla L^1$  and  $\nabla L^2$  are full-row ranked.

$$\begin{aligned} \nabla_{n_3} L^3 = & \left[ -\nabla_{b_{1,k_i}^i} [B^i \phi^i] \quad \dots \quad -\nabla_{b_{k_i,k_i}^i} [B^i \phi^i] \quad -\nabla_{b_{k_i,k_i+1}^i} [B^i \phi^i] \quad \dots \quad -\nabla_{b_{k_i,k_i+N}^i} [B^i \phi^i] \right] \\ = & \begin{bmatrix} -\phi_{k_i}^i & 0 & \dots & 0 & 0 & \dots & 0 \\ 0 & -\phi_{k_i}^i & \dots & 0 & 0 & \dots & 0 \\ \vdots & \vdots & & & & & \\ -\phi_1^i & -\phi_2^i & \dots & -\phi_{k_i}^i & -\phi_{k_i+1}^i & \dots & -\phi_N^i \\ 0 & 0 & \dots & 0 & -\phi_{k_i}^i & \dots & 0 \\ \vdots & \vdots & & & & & \\ 0 & 0 & \dots & 0 & 0 & \dots & -\phi_{k_i}^i \end{bmatrix}. \end{aligned} \quad (\text{A.49})$$

By elementary row and column operations, it can be show that  $\nabla_{n_3} L^3$  is full-row ranked, which will imply that  $\nabla L^3$  is full-row ranked. Further, note that  $\nabla_{\mathbf{n}_t} \mathcal{L}^{t+1} = 0$  for  $t \in \{1, 2\}$ . Hence, the conclusions of Lemma FRR can be employed to show that  $\nabla L$ , which is the same as  $\nabla \tilde{\Gamma}_{\mathbf{y}}^i$ , is full-row ranked. ■

**Lemma SBPCI.iii:**  $\tilde{\Gamma}_{\mathbf{y}}^0 \pitchfork 0$ .

**Proof:** Follow exactly similar steps as in the proof of Lemma SBPCI.ii for defining functions  $L^1$  and  $L^2$ , proving that  $\nabla L^1$  and  $\nabla L^2$  are full-row ranked. Note that  $\nabla_{\mathbf{n}_1} L^2$  is zero. It thus follows from Lemma FRR that  $\nabla L$ , which is equal to  $\nabla \tilde{\Gamma}_{\mathbf{y}}^0$ , is full-row ranked. ■

**Lemma SBPCI.iv:**  $\tilde{\Gamma}_{\beta} \pitchfork 0$ .

**Proof:** Consider the following  $N \times N$  submatrix of  $\nabla \tilde{\Gamma}_{\beta}$ .

$$\nabla_{y^0} \tilde{\Gamma}_{\beta} = \begin{bmatrix} 1 & 0 & \dots & 0 \\ 0 & 1 & \dots & 0 \\ \vdots & & & \\ 0 & 0 & \dots & 1 \end{bmatrix}. \quad (\text{A.50})$$

Thus,  $\nabla_{y^0} \tilde{\Gamma}_{\beta}$  is full-row ranked. Hence, the matrix  $\nabla \tilde{\Gamma}_{\beta}$ , which has  $N$  rows, is full-row ranked. ■

**Lemma SBPCI.v:**  $\tilde{\Gamma}_{\mathbf{p}, \gamma} \pitchfork 0$ .

**Proof:** Note that for all  $i \neq 0$ , The second set of functions in  $\tilde{\Gamma}_{\mathbf{p}, \gamma}$  are independent of  $\phi_1^i$ . We apply Lemma FRR with  $T = 2$ ,  $L^1$  and  $L^2$  being the first and the second set of functions in  $\tilde{\Gamma}_{\mathbf{p}, \gamma}$ . Hence,  $M^1 = I$  and  $M^2 = N - 1$ . Let  $n_1 = \{\phi_1^1, \dots, \phi_1^I\}$  and  $n_2 = \{\phi_2^1, \dots, \phi_N^1\}$ . Recalling our normalization  $p_1 = 1$ , we have

$$\nabla_{n_1} L^1 = \mathcal{I}_I \quad (\text{A.51})$$

and

$$\nabla_{n_2} L^2 = \gamma^1 \mathcal{I}_{N-2}. \quad (\text{A.52})$$

Thus, both  $\nabla_{n_1} L^1$  and  $\nabla_{n_2} L^2$  are full-row ranked, and hence  $\nabla L^1$  and  $\nabla L^2$  are full-row ranked. Further, since  $L^2$  is independent of  $n_1$ , we have  $\nabla_{n_1} L^2$  is zero. Conclusions of Lemma FRR follow, and  $\nabla L$ , which is equal to  $\nabla \tilde{\Gamma}_{\mathbf{p}, \gamma}$ , is full-row ranked. ■

**Lemma SBPCI.vi:**  $\tilde{\Gamma}_{\mathbf{p}, \lambda, \psi} \pitchfork 0$ .

**Proof:** From Lemmas SB1 and SB2 it follows that if  $\tilde{\Gamma}(u^1, \dots, u^H, r, c, l) = 0$  then  $c$  is a production and consumption inefficient tax equilibrium and  $\kappa^h \neq 0$  and  $\phi^i \neq 0$  for all  $h$  and  $i \neq 0$ . Lemma SB3 implies that there exists  $h'$  such that  $\psi^{h'} \neq 0$ . Pick a firm  $i \neq 0$ . We will apply Lemma FRR. For this purpose  $T = 3$  and we define  $L^1$ ,  $L^2$ , and  $L^3$  to be the first, second, and third set of functions in  $\tilde{\Gamma}_{\mathbf{p}, \lambda, \psi}$ , respectively. Define the sets  $n_1 = \{\theta_i^1, \dots, \theta_i^H\}$ ,  $n_2 = \{e_1^{h'}, \dots, e_N^{h'}\}$ , and  $n_3 = \{\kappa_1^1, \dots, \kappa_1^H\}$ . Then

$$\nabla_{n_1} L^1 = -p^T y^i \mathcal{I}_H, \quad (\text{A.53})$$

$$\nabla_{n_2} L^2 = \psi^{h'} \mathcal{I}_N, \quad (\text{A.54})$$

and

$$\nabla_{n_3} L^3 = q_1 \mathcal{I}_H. \quad (\text{A.55})$$

Clearly, all the matrices above are full-row ranked.<sup>61</sup> Hence,  $\nabla L^1$ ,  $\nabla L^2$ , and  $\nabla L^3$  are full-row ranked. Further,  $\nabla_{\mathbf{n}_t} L^{t+1} = 0$  for all  $t \in \{1, 2\}$ . Conclusions of Lemma FRR follow, and  $\nabla L$ , which is equal to  $\tilde{\Gamma}_{\mathbf{p}, \boldsymbol{\lambda}, \boldsymbol{\psi}}$ , is full-row ranked. ■

**Lemma SBPCI.vii:**  $\tilde{\Gamma}_{\mathbf{R}} \triangleright 0$ .

**Proof:** This follows from the fact that  $\nabla_{\psi^h} \tilde{\Gamma}_{\mathbf{R}} = 1$  for all  $h$ . ■

**Lemma SBPCI.viii:**  $\tilde{\Gamma}_{\mathbf{u}} \triangleright 0$ .

**Proof:** Consider the  $[H - 1] \times [H - 1]$  submatrix of  $\tilde{\Gamma}_{\mathbf{u}}$  obtained from the derivatives of  $\tilde{\Gamma}_{\mathbf{u}}$  with respect to  $u^2, \dots, u^H$ . This is clearly the identity matrix  $\mathcal{I}_{H-1}$ . Thus,  $\nabla \tilde{\Gamma}_{\mathbf{u}}$  is full-row ranked. ■

**Proof of Lemma SBPCI:** We will employ Lemmas SBPCI.i to SBPCI.viii and Lemma FRR. Suppose  $\tilde{\Gamma}(u^1, \dots, u^H, r, c, l) = 0$ . We prove that  $\nabla \tilde{\Gamma}(u^1, \dots, u^H, r, c, l)$  is full-row ranked. In order to apply Lemma FRR, let  $T = H + I + 6$ . Define

$$\left[ \begin{array}{l} L^1() = \tilde{\Gamma}_{\mathbf{x}}^1() \\ \vdots \\ L^H() = \tilde{\Gamma}_{\mathbf{x}}^H() \\ L^{H+1}() = \tilde{\Gamma}_{\mathbf{y}}^1() \\ \vdots \\ L^{H+I}() = \tilde{\Gamma}_{\mathbf{y}}^I() \\ L^{H+I+1}() = \tilde{\Gamma}_{\mathbf{y}}^0() \\ L^{H+I+2}() = \tilde{\Gamma}_{\boldsymbol{\beta}}() \\ L^{H+I+3}() = \tilde{\Gamma}_{\mathbf{p}, \boldsymbol{\gamma}}() \\ L^{H+I+4}() = \tilde{\Gamma}_{\mathbf{q}, \boldsymbol{\lambda}, \boldsymbol{\psi}}() \\ L^{H+I+5}() = \tilde{\Gamma}_{\mathbf{R}}() \\ L^{H+I+6}() = \tilde{\Gamma}_{\mathbf{u}}() \end{array} \right]. \quad (\text{A.56})$$

Let  $n_h = \{a^h, A^h\}$  for  $h = 1, \dots, H$ ,  $n_{H+i} = \{b^i, B^i\}$  for  $i \neq 0$ ,  $n_{H+I+1} = \{b_0^0, b^0, B^0\}$ ,  $n_{H+I+2} = \{y^0\}$ ,  $n_{H+I+3} = \{\phi_1^1, \dots, \phi_1^I, \phi_2^1, \dots, \phi_N^1\}$ ,  $n_{H+I+4} = \{\theta_i^1, \dots, \theta_i^H, e_1^{h'}, \dots, e_N^{h'}, \kappa_1^1, \dots, \kappa_1^H\}$ ,  $n_{H+I+5} = \{\psi^h\}$ , and  $n_{H+I+6} = \{u^2, \dots, u^H\}$ . Lemmas SBPCI.i to SBPCI.viii show that  $\nabla_{\mathbf{n}_t} L^t$  is full-row ranked for  $t = 1, \dots, H + I + 6$ . Further, it can be easily verified

<sup>61</sup> Note that, for all  $i \neq 0$ , given our regularity assumptions on the technology  $Y^i$ , in the construction of our class of economies  $\mathcal{E}$ ,  $\mathbf{b}$  can be picked so that the perturbations of the zero<sup>th</sup> order derivatives of the production functions can be restricted to those that imply that all private firms continue to make positive profits in the new economies.



that  $\nabla_{\mathbf{n}_t} L^{t+1}$  is zero for all  $t = 1, \dots, H + I + 5$ . Conclusions of Lemma FRR follow, and  $\nabla L$ , which is equal to  $\nabla \tilde{\Gamma}$ , is full-row ranked. Hence,  $\tilde{\Gamma} \pitchfork 0$ . ■

**Proof of Theorem SBPC1:** Let  $r \in \tilde{\mathcal{R}}$  and let  $\bar{u} = \langle \bar{u}^1, \dots, \bar{u}^H \rangle \in \tilde{U}(r) \subset U(r)$ . We show that there exists a set  $V$ , which is open in  $U(r)$  and contains  $\bar{u}$ , such that  $V \cap \tilde{U}(r)$  is homeomorphic to an open set in  $\mathbf{R}^{H-1}$ .

Since  $\bar{u} \in \tilde{U}(r) \subset U(r)$ , it follows that there exists  $\langle \bar{c}, \bar{l} \rangle \in \mathcal{C} \times \mathbf{R}^{n_l}$  such that  $\langle \bar{c}, \bar{l} \rangle \in \Phi_r^*(\bar{u}^2, \dots, \bar{u}^H)$ . From Assumption SB1 (b), this implies that there exists  $j \in \tilde{J}_{\bar{u}^2, \dots, \bar{u}^H}^*(r)$  such that  $\mathbf{g}_{\mathbf{r}, \bar{u}^2, \dots, \bar{u}^H}^j(\bar{u}^2, \dots, \bar{u}^H) = \langle \bar{c}, \bar{l} \rangle$ . Define the set  $\hat{V}_{\bar{u}^2, \dots, \bar{u}^H}^j(r)$  as in Theorem SB and the set  $O_{\bar{u}^2, \dots, \bar{u}^H}^j(r)$  as in Assumption SB1 (b).

From Lemma SBPCI and Remark SBPCI we have  $\tilde{\Gamma}_r \pitchfork 0$  and  $\tilde{\Gamma}_r^{-1}(0)$ , which we denote by  $\tilde{\Gamma}(r)$ , is a smooth manifold of dimension  $H - 1$ .  $\langle \bar{u}^2, \dots, \bar{u}^H, \bar{c}, \bar{l} \rangle \in \tilde{\Gamma}(r)$ . Hence there exists an open set  $O$  in  $\mathcal{P}(r) \times \mathcal{C} \times \mathbf{R}^{n_l}$  such that  $O \cap \tilde{\Gamma}(r)$  is diffeomorphic to an open set in  $\mathbf{R}^{H-1}$ .

Define  $Z^j = \hat{V}_{\bar{u}^2, \dots, \bar{u}^H}^j(r) \times O_{\bar{u}^2, \dots, \bar{u}^H}^j(r)$ . As a Cartesian product of two open sets,  $Z^j$  is open in  $\mathcal{P}(r) \times \mathcal{C} \times \mathbf{R}^{n_l}$ . As an intersection of two open sets,  $Z^j \cap O$  is open in  $\mathcal{P}(r) \times \mathcal{C} \times \mathbf{R}^{n_l}$ . Moreover, Assumption SB1 (b) implies that  $Z^j \cap O \cap \Gamma(r) = Gr(\mathbf{g}_{\mathbf{r}, \bar{u}^2, \dots, \bar{u}^H}^j) \cap Z^j \cap O$ . Define the homeomorphism  $\zeta$  as in Theorem SB. Define  $V := \zeta(Z^j \cap O \cap \Gamma(r))$ . Then, from Theorem SB,  $V$  is an open subset of  $U(r)$ .

Since  $\tilde{\Gamma}(r) \subset \Gamma(r)$ , we have  $Z^j \cap O \cap \tilde{\Gamma}(r) \subset Gr(\mathbf{g}_{\mathbf{r}, \bar{u}^2, \dots, \bar{u}^H}^j) \cap Z^j \cap O = Z^j \cap O \cap \Gamma(r)$ . Further, since  $\tilde{\Gamma}(r)$  is a  $H - 1$ -dimensional manifold, we have  $Z^j \cap O \cap \tilde{\Gamma}(r)$  is a  $H - 1$ -dimensional submanifold of  $Z^j \cap O \cap \Gamma(r)$ . Hence,  $\zeta(Z^j \cap O \cap \tilde{\Gamma}(r))$  is a  $H - 1$ -dimensional submanifold of  $V$  and, clearly,  $\zeta(Z^j \cap O \cap \tilde{\Gamma}(r)) = V \cap \tilde{U}(r)$ . ■

**Proof of Lemma SBPE1:** We need to show that for all  $\langle r, (u^h)_{h \neq 1}, c, l \rangle \in \mathcal{A}$ , the Jacobian  $\nabla \bar{\Gamma}(r, (u^h)_{h \neq 1}, c, l)$  is full-row ranked.

*Claim 1.* For all  $h$ ,  $\nabla \bar{\Gamma}_{\mathbf{x}}^h$ ,  $\nabla \bar{\Gamma}_{\mathbf{y}}^0$ ,  $\nabla \bar{\Gamma}_{\boldsymbol{\beta}}$ ,  $\nabla \bar{\Gamma}_{\mathbf{R}}$ , and  $\nabla \bar{\Gamma}_{\mathbf{u}}$  are full-row ranked: Proofs are the same as in Lemmas SBPCI.i, SBPCI.iii, SBPCI.iv, SBPCI.vii, and SBPCI.viii.

*Claim 2.* For all  $i \neq 0$ ,  $\nabla \bar{\Gamma}_{\mathbf{y}}^i$  is full-row ranked: Lemma FRR can be applied with  $T = 3$ ,  $L^1$ ,  $L^2$ , and  $L^3$  being the first, second, and the third sets of equations in  $\nabla \bar{\Gamma}_{\mathbf{y}}^i$ .  $n_1 = \{b_0^i\}$ ,  $n_2 = \{b^i\}$ , and  $n_3 = \{\mu^i\}$ .

*Claim 3.*  $\nabla \bar{\Gamma}_{\mathbf{q}, \boldsymbol{\lambda}, \boldsymbol{\psi}}^i$  is full-row ranked: There exists  $i$  such that  $\sum_h \psi^h \theta_i^h \neq 0$  and since we are not at a first-best, Lemma SB3 implies that there exists  $h$  such that  $\psi^h \neq 0$ . Without loss of generality, assume that  $i = 1$  and  $h = 1$ . We extract the submatrix of  $\nabla \bar{\Gamma}_{\mathbf{q}, \boldsymbol{\lambda}, \boldsymbol{\psi}}^i$

obtained by differentiating  $\bar{\Gamma}_{\mathbf{q},\boldsymbol{\lambda},\boldsymbol{\psi}}$  with respect to  $y^1$ ,  $e^1$ ,  $\kappa_1^1, \dots, \kappa_1^H$ , and  $\theta_1^1, \dots, \theta_1^H$ . With no loss of generality assume  $N = 3$  and  $H = 2$ . This yields the following matrix.

$$\left[ \nabla_{y^1} \bar{\Gamma}_{\mathbf{q},\boldsymbol{\lambda},\boldsymbol{\psi}} \quad \nabla_{\kappa_1^1} \bar{\Gamma}_{\mathbf{q},\boldsymbol{\lambda},\boldsymbol{\psi}} \quad \nabla_{\kappa_1^2} \bar{\Gamma}_{\mathbf{q},\boldsymbol{\lambda},\boldsymbol{\psi}} \quad \nabla_{e^1} \bar{\Gamma}_{\mathbf{q},\boldsymbol{\lambda},\boldsymbol{\psi}} \quad \nabla_{\theta_1^1} \bar{\Gamma}_{\mathbf{q},\boldsymbol{\lambda},\boldsymbol{\psi}} \quad \nabla_{\theta_1^2} \bar{\Gamma}_{\mathbf{q},\boldsymbol{\lambda},\boldsymbol{\psi}} \right] = \quad (\text{A.57})$$

$$\begin{bmatrix} 0 & \sum_h \psi^h \theta_1^h & 0 & 0 & 0 & 0 & 0 & 0 & \psi^1 y_2^1 & \psi^2 y_2^1 \\ 0 & 0 & \sum_h \psi^h \theta_1^h & 0 & 0 & 0 & 0 & 0 & \psi^1 y_3^1 & \psi^2 y_3^1 \\ 0 & 0 & 0 & q_1 & 0 & 0 & 0 & 0 & 0 & 0 \\ 0 & 0 & 0 & 0 & q_1 & 0 & 0 & 0 & 0 & 0 \\ 0 & 0 & 0 & \lambda^1 & \lambda^2 & \psi^1 & 0 & 0 & 0 & 0 \\ 0 & 0 & 0 & 0 & 0 & 0 & \psi^1 & 0 & 0 & 0 \\ 0 & 0 & 0 & 0 & 0 & 0 & 0 & \psi^1 & 0 & 0 \\ -\theta_1^1 p_1 & -\theta_1^1 p_2 & -\theta_1^1 p_3 & 0 & 0 & -q_1 & -q_2 & -q_3 & -p^T y^1 & 0 \\ -\theta_1^2 p_1 & -\theta_1^2 p_2 & -\theta_1^2 p_3 & 0 & 0 & 0 & 0 & 0 & 0 & -p^T y^1 \end{bmatrix} =: J \quad (\text{A.58})$$

Define a  $10 \times 9$  matrix of perturbations  $Z$ , whose  $k^{\text{th}}$  column has the structure

$$z^k = \begin{bmatrix} dy_1^1 \\ dy_2^1 \\ dy_3^1 \\ d\kappa_1^1 \\ d\kappa_1^2 \\ de_1^1 \\ de_2^1 \\ de_3^1 \\ d\theta_1^1 \\ d\theta_1^2 \end{bmatrix}. \quad (\text{A.59})$$

Define

$$z^1 = \begin{bmatrix} -\frac{p_2}{p_1 \sum_h \psi^h \theta_1^h} \\ \frac{1}{\sum_h \psi^h \theta_1^h} \\ 0 \\ 0 \\ 0 \\ 0 \\ 0 \\ 0 \\ 0 \\ 0 \end{bmatrix}, \quad z^2 = \begin{bmatrix} -\frac{p_3}{p_1 \sum_h \psi^h \theta_1^h} \\ 0 \\ \frac{1}{\sum_h \psi^h \theta_1^h} \\ 0 \\ 0 \\ 0 \\ 0 \\ 0 \\ 0 \\ 0 \end{bmatrix}, \quad z^3 = \begin{bmatrix} 0 \\ 0 \\ 0 \\ \frac{1}{q_1} \\ 0 \\ -\frac{\lambda^1}{q_1 \psi^1} \\ 0 \\ 0 \\ 0 \\ 0 \end{bmatrix}, \quad z^4 = \begin{bmatrix} 0 \\ 0 \\ 0 \\ 0 \\ \frac{1}{q_1} \\ 0 \\ -\frac{\lambda^2}{q_1 \psi^1} \\ 0 \\ 0 \\ 0 \end{bmatrix}, \quad (\text{A.60})$$

$$z^5 = \begin{bmatrix} 0 \\ 0 \\ 0 \\ 0 \\ 0 \\ \frac{1}{\psi^1} \\ 0 \\ 0 \\ -\frac{q_1}{\psi^1 p^T y^1} \\ 0 \end{bmatrix}, \quad z^6 = \begin{bmatrix} 0 \\ 0 \\ 0 \\ 0 \\ 0 \\ 0 \\ \frac{1}{\psi^1} \\ 0 \\ -\frac{q_1}{\psi^1 p^T y^1} \\ 0 \end{bmatrix}, \quad z^7 = \begin{bmatrix} 0 \\ 0 \\ 0 \\ 0 \\ 0 \\ 0 \\ 0 \\ \frac{1}{\psi^1} \\ -\frac{q_1}{\psi^1 p^T y^1} \\ 0 \end{bmatrix}, \quad (\text{A.61})$$

$$z^8 = \begin{bmatrix} dy_1^1 = \frac{-p_2}{p_1} dy_2^1 \\ dy_2^1 = \frac{-\psi^1 y_2^1}{p^T y^1 \sum_h \psi^h \theta_1^h} d\theta_1^1 \\ 0 \\ 0 \\ 0 \\ 0 \\ 0 \\ 0 \\ 0 \\ d\theta_1^1 = \frac{-1}{p^T y^1} \\ 0 \end{bmatrix}, \quad \text{and } z^9 = \begin{bmatrix} dy_1^1 = \frac{-p_3}{p_1} dy_3^1 \\ 0 \\ dy_3^1 = \frac{-\psi^1 y_3^1}{p^T y^1 \sum_h \psi^h \theta_1^h} d\theta_1^2 \\ 0 \\ 0 \\ 0 \\ 0 \\ 0 \\ 0 \\ 0 \\ d\theta_1^2 = \frac{-1}{p^T y^1} \end{bmatrix}. \quad (\text{A.62})$$

Thus,  $JZ = \mathcal{I}_{9 \times 9}$ . Which implies that  $J$  is full-row ranked. In the general case, one can define a  $2(N + H) \times (2N - 1 + 2H)$  matrix of perturbations  $Z$  and show that  $JZ$  is an identity matrix of dimension  $2N - 1 + 2H$ . This implies that  $\nabla \bar{\bar{\Gamma}}_{\mathbf{q}, \boldsymbol{\lambda}, \boldsymbol{\psi}}$  is full-row ranked.

*Claim 4.*  $\nabla \bar{\bar{\Gamma}}_*$  and  $\nabla \bar{\bar{\Gamma}}_{\boldsymbol{\phi}}$  are full-row ranked: True as  $\nabla_{\hat{p}} \bar{\bar{\Gamma}}_* = \mathcal{I}_{(N-1) \times (N-1)}$  and  $\nabla_{(\phi^i)_{i \neq 0}} \bar{\bar{\Gamma}}_{\boldsymbol{\phi}} = \mathcal{I}_{IN \times IN}$

*Claim 5.*  $\bar{\bar{\Gamma}} \pitchfork 0$ : We apply Lemma FRR with  $T = H + I + 7$ . The functions  $L^1, \dots, L^H$  correspond to  $\bar{\bar{\Gamma}}_{\mathbf{x}}^1, \dots, \bar{\bar{\Gamma}}_{\mathbf{x}}^H$ ,  $L^{H+i}$  corresponds to  $\bar{\bar{\Gamma}}_{\mathbf{y}}^i$ ,  $L^{H+I+2}$  corresponds to  $\bar{\bar{\Gamma}}_{\boldsymbol{\beta}}$ ,  $L^{H+3}$  corresponds to  $\bar{\bar{\Gamma}}_{\mathbf{q}, \boldsymbol{\lambda}, \boldsymbol{\psi}}$ ,  $L^{H+4}$  corresponds to  $\bar{\bar{\Gamma}}_{\mathbf{R}}$ ,  $L^{H+5}$  corresponds to  $\bar{\bar{\Gamma}}_{\mathbf{u}}$ ,  $L^{H+6}$  corresponds to  $\bar{\bar{\Gamma}}_*$ , and  $L^{H+7}$  corresponds to  $\bar{\bar{\Gamma}}_{\boldsymbol{\phi}}$ . Define  $n_h = \{a^h, A^h\}$ ,  $\forall h = 1, \dots, H$ ,  $n_{H+i} = \{\mu^i, (b_0^i), (b^i)_i\}$  for  $i \neq 0$ ,  $n_{H+I+1} = \{b_0^0, b^0\}$ ,  $n_{H+I+2} = \{y^0\}$ ,  $n_{H+I+3} = \{e^1, y^1, (\kappa_1^h)_h, (\theta_1^h)_h\}$ ,  $n_{H+I+4} = \{\psi^1\}$ ,  $n_{H+I+5} = \{u^2, \dots, u^H\}$ ,  $n_{H+I+6} = \{\hat{p}\}$  and  $n_{H+I+7} = \{(\phi^i)_{i \neq 0}\}$ . Given Claims 1 to 4, it can be verified that these definitions satisfy all the assumptions of Lemma FRR and the conclusions of the lemma follow.

Thus,  $\nabla \bar{\bar{\Gamma}}$  is full-row ranked whenever  $\bar{\bar{\Gamma}}((u^h)_{h \neq 1}, r, c, l) = 0$ , that is, whenever  $\langle r, (u^h)_{h \neq 1}, c, l \rangle \in \mathcal{A}$ . ■

**Proof of Lemma SBPE2:** We need to show that for all  $\langle r, (u^h)_{h \neq 1}, c, l \rangle \in \mathcal{B}$ , the Jacobian  $\nabla \bar{\bar{\Gamma}}(r, (u^h)_{h \neq 1}, c, l)$  is full-row ranked.

*Claim 1.* For all  $h$ ,  $\nabla \bar{\bar{\Gamma}}_{\mathbf{x}}^h$ ,  $\nabla \bar{\bar{\Gamma}}_{\mathbf{y}}^0$ ,  $\nabla \bar{\bar{\Gamma}}_{\boldsymbol{\beta}}$ ,  $\nabla \bar{\bar{\Gamma}}_{\mathbf{R}}$ ,  $\nabla \bar{\bar{\Gamma}}_{\mathbf{u}}$ ,  $\nabla \bar{\bar{\Gamma}}_{\mathbf{y}}^i$ ,  $\nabla \bar{\bar{\Gamma}}_{*}$ , and  $\nabla \bar{\bar{\Gamma}}_{\boldsymbol{\phi}}$  are full-row ranked: Proof is the same as in Lemmas SBPCI.i, SBPCI.iii, SBPCI.vii, and SBPCI.viii and Claims 2 and 4 in the proof of Lemma SBPE.1 above.

*Claim 2.*  $\nabla \bar{\bar{\Gamma}}_{\mathbf{q}, \boldsymbol{\lambda}, \boldsymbol{\psi}}$  is full-row ranked: Since, we are not at a first-best, Lemma SB3 implies that there exists  $h'$  such that  $\psi^{h'} \neq 0$ . We apply Lemma FFR. Let  $T = 4$  and define the functions  $L^1, L^2, L^3$  and  $L^4$  to be the first, second, third, and fourth set of functions in  $\bar{\bar{\Gamma}}_{\mathbf{q}, \boldsymbol{\lambda}, \boldsymbol{\psi}}$ . Define  $n_1 = \{e^1\}$ ,  $n_2 = \{\kappa_1^h, \dots, \kappa_N^h\}$ ,  $n_3 = \{e_1^2, \dots, e_N^H\}$ , and  $n_4 = \{\theta_{h'}^1, \dots, \theta_{h'}^I\}$ . It can be verified easily that these choices will satisfy all the assumptions in Lemma FRR and the conclusions of the this lemma will follow.

*Claim 3.*  $\nabla \bar{\bar{\Gamma}}$  is full-row ranked: Lemma FRR can be applied, with  $T = H + I + 7$ .  $L^1$  to  $L^H$  correspond to functions  $\bar{\bar{\Gamma}}_{\mathbf{x}}^1$  to  $\bar{\bar{\Gamma}}_{\mathbf{x}}^H$ , respectively,  $L^{H+i}$  for  $i \neq 0$  corresponds to  $\bar{\bar{\Gamma}}_{\mathbf{y}}^i$ ,  $L^{H+I+1}$  to  $L^{H+I+7}$  correspond to  $\bar{\bar{\Gamma}}_{\mathbf{y}}^0$ ,  $\bar{\bar{\Gamma}}_{\boldsymbol{\beta}}$ ,  $\bar{\bar{\Gamma}}_{\mathbf{R}}$ ,  $\bar{\bar{\Gamma}}_{\mathbf{q}, \boldsymbol{\lambda}, \boldsymbol{\psi}}$ ,  $\bar{\bar{\Gamma}}_{\mathbf{u}}$ ,  $\bar{\bar{\Gamma}}_{*}$ , and  $\bar{\bar{\Gamma}}_{\boldsymbol{\phi}}$ , respectively. Define  $n_h = \{a^h, A^h\}$  for  $h = 1, \dots, H$ ,  $n_{H+i} = \{\beta, (b_0^i, b^i)_{i \neq 0}\}$  for  $i \neq 0$ ,  $n_{H+I+1} = \{b_0^0, b^0\}$ ,  $n_{H+I+2} = \{y^0\}$ ,  $n_{H+I+3} = \{\psi^h\}$ ,  $n_{H+I+4} = \{e^1, \kappa_1^1, \dots, \kappa_1^H, e_1^2, \dots, e_1^H, \theta_1^{h'}, \dots, \theta_I^{h'}\}$ ,  $n_{H+I+5} = \{u^2, \dots, u^H\}$ ,  $n_{H+I+6} = \{\hat{p}\}$ , and  $n_{H+I+7} = \{(\phi^i)_{i \neq 0}\}$ . It can be verified that all the assumptions of Lemma FRR hold for these choices. Hence, conclusions of the lemma follow and  $\nabla L$ , which is the same as  $\nabla \bar{\bar{\Gamma}}$ , is full-row ranked. ■

## REFERENCES

- Balasko, Y., *Foundations of the theory of general equilibrium*, Economic theory, econometrics, and mathematical economics, Academic Press, INC, 1998.
- Blackorby, C. and S. Murty, “Constraints on income distribution and production efficiency in economies with Ramsey taxation” The Warwick economics research papers series, No. 908, 2009.
- Boadway, R., “Cost benefit rules in general equilibrium” *Review of economic studies* **42**, 1975, 361-74.
- Carvajal, A. and H. Polemarchakis, “Idiosyncratic risk and economic policy” A draft, July 2009.
- Citanna, A., A. Kajii, and A. Villanacci, “Constrained suboptimality in incomplete markets: a general approach and two applications” *Economic theory* **11**, 1998, 495-521.
- Debreu, G., “Economies with finite set of equilibria” *Econometrica* **38**, 1970, 387-92.
- Debreu, G., *Theory of value*, Yale, 1959.
- Dasgupta, P. and J. Stiglitz, “On optimal taxation and public production” *Review of economic studies* **39**, 1972, 87-103.

- Diamond, P. and J. Mirrlees, "Optimal taxation and public production I: production efficiency" *American economic review* **61**, 1971, 8-27.
- Diamond, P. and J. Mirrlees, "Optimal taxation and public production II: tax rules" *American economic review* **61**, 1971, 261-78.
- Drèze, J. and N. Stern, *The theory of cost benefit analysis* in Handbook of public economics, editors: A. J. Auerbach and M. Feldstein, **II**, Chapter 14, Elsevier science publishers, North Holland, 1987.
- Fuchs, G. and R. Guesnerie, "Structure of tax equilibria" *Econometrica* **51**, 1983, 403-34.
- Geanakopolas, J. and H. Polemarchakis, "The existence and regularity of tax equilibria" A draft, April 2009.
- Geanakopolas, J. and H. Polemarchakis, *Existence, regularity, and constrained suboptimality of competitive allocations when the asset market is incomplete* in Essays in honor of Kenneth J. Arrow, editors: W. P. Heller, R. M. Starr, and D. A. Starrett, **III**, Part 1, Chapter 3, Cambridge, 1986.
- Guesnerie, R., *A Contribution to the pure theory of taxation*, Cambridge, UK, 1998.
- Guesnerie, R., "Financing public goods with commodity taxes: the tax reform viewpoint" *Econometrica* **47**, 1979, 393-421.
- Hahn, F., "On optimum taxation" *Journal of economic theory* **6**, 1973, 96-106.
- Keen, M. and B. Lockwood, "The value added tax: its causes and consequences" forthcoming *Journal of development economics*, 2007.
- Mas-Colell A., M. Whinston, and J. Green, *Microeconomic theory*, Oxford, 1995.
- Mirrlees, J., "On producer taxation" *Review of economic studies* **39**, 1972, 105-111.
- Ramsey, F., "A contribution to the theory of taxation" *Economic journal* **37**, 1927, 47-61.
- Reinhorn, L., "Production efficiency and excess supply" A draft, 2005.
- Sadka, E., "A note on producer taxation" *Review of economic studies* **44**, 1977, 385-87.
- Shoven, J. B., "A proof of the existence of a general equilibrium with ad valorem commodity taxes" *Journal of economic theory* **8**, 1973, 1-25.
- Villanacci, A., L. Carosi, P. Benevieri, and A. Batinelli, *Differential topology and general equilibrium with complete and incomplete markets*, Kluwer, 2002.
- Zeckhauser, R. and M. Weinstein, "The topology of Pareto optimal regions with public goods" *Econometrica* **42**, 1974, 643-66.