

Investigating Forms and Formwork in the Nave Aisles at Tewkesbury Abbey

James Hillson, Alexandrina Buchanan & Nicholas Webb
University of Liverpool, Liverpool, UK

ABSTRACT: Recent study of medieval vaults using digital scanning methods has tended to focus on the design and construction of the ribs, with less scholarly attention being directed towards the webs in between. The study of webbing has been impeded by the limitations of both the raw data and the range of research methods which are available to architectural historians. In England the majority of vault webs are plastered or whitewashed, making it impossible to study the stonework directly. Even when the masonry is visible, there are no contemporary textual sources which can be used to identify the kinds of centering which could have been employed to support their construction. Furthermore, the complex and irregular three-dimensional forms of webs cannot easily be assessed using existing techniques for analysing vault geometries, which focus on reducing three-dimensional forms to two-dimensional design processes. This paper focuses on a series of vaults which were added to the eleventh-century nave aisles of Tewkesbury as part of an extensive fourteenth-century remodelling scheme. The surface of these understudied vaults is unplastered, revealing an unusual cambered surface of webbing constructed using atypical, irregular coursing. Whilst the ribs were doubtless constructed using inflexible wooden centres, this is not necessarily the case for the webs themselves. This paper considers whether or not formwork was used in erecting the webbing at Tewkesbury, using a variety of digital methods including contour analysis, course tracing and normal vector mapping to investigate the structure and three-dimensional curvature of the masonry.

1 INTRODUCTION

Our research project, 'Tracing the Past' (www.tracingthepast.org.uk), uses experimental digital methods to investigate the design and construction of English vaults between the eleventh and sixteenth centuries. The innovations which took place during this period were fundamental to the ongoing development of European architecture, with the emergence of ribbed vaults, tiercerons, liernes and fan vaulting dramatically increasing the range of possibilities available to medieval designers. Yet whilst many studies of medieval vaults have attempted to understand them by analysing the geometry of their ribs, relatively few have focused on the masonry between them. These webs are seldom visible in English buildings, as they are usually covered by layers of plaster or whitewash. However, in the few cases where the masonry of the webbing is exposed, its form and structure raise many questions regarding its design and construction process.

The consensus among architectural historians is that a vault's ribs were erected with the aid of some kind of formwork or centering. The designs for each rib would be worked out at a 1:1 scale, probably using lines and arcs incised into a plaster or stone surface conventionally called a tracing floor (Pacey 2007). The resulting arcs would then be converted into a set of stone components through a process of projection, facilitated by a set of templates giving the profile, curvature and angle of the joints between each block. Once the walls had been raised and *tas-de-charge* blocks inserted, a wooden framework would then be assembled spanning the vault bay, probably taking the form of a series of wooden arches corresponding to the curvatures of the ribs above. Bosses would be placed at the apexes of these arches and *voussoirs* would then be laid to meet them from the *tas-de-charge* upwards, eventually forming a self-supporting framework of stone arches defining the outer bounds of the webs. Yet though it is practically certain that formwork was essential for erecting the ribs, this is not necessarily the case for the webbing. At some sites the three-dimensional curvatures of the webs and the cambered courses of stones raise the possibility that some of these surfaces may have been self-supporting, requiring no formwork beyond the ribs themselves.

This paper reopens the question of whether or not formwork was necessarily used in the construction of webbing by focusing on a single targeted case study: the fourteenth-century nave aisle vaults at Tewkesbury Abbey (Figure 1). Despite the apparent simplicity of their plan, the geometry of the ribs in these bays is remarkably complex, an observation equally reflected in the structure of the webs. The exposed surfaces of their masonry reveal a complex pattern of interlacing courses, with a unique arrangement appearing in every bay. As we have demonstrated previously in our studies of vault ribs (Buchanan & Webb 2017a, 2017b, 2018, 2019), digital technologies present a range of new techniques for analysing the masonry patterns and three-dimensional forms of these webs. This paper describes these analytical tools and demonstrates how they can be applied to studying the form and structure of the vaults at Tewkesbury, with a particular emphasis on how they were constructed and whether or not formwork could have been involved.



Figure 1. Tewkesbury Abbey, north nave aisle, bay N8, mesh model, perspective view facing northeast.

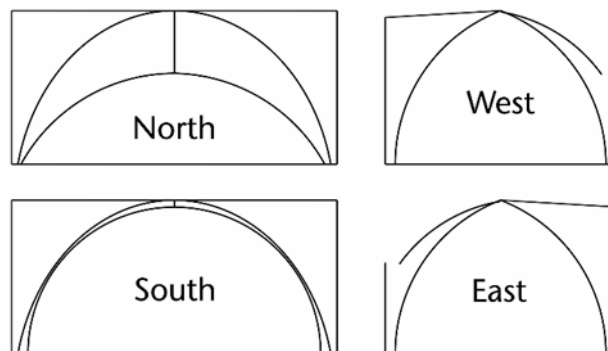

Figure 2. Tewkesbury Abbey, bay N8, design hypothesis.

2 FORM AND STRUCTURE

The community that became Tewkesbury Abbey was originally a Benedictine religious house founded at Cranborne (Dorset) in c. 715. During the late eleventh century, the Earl of Gloucester Robert Fitzhamon (d. 1107) decided to move the abbey to its present site at Tewkesbury, starting construction of a new church on a far larger scale. Begun after 1087, the first phase of works was probably largely completed during the 1090s, with the monks moving into their new buildings in 1102. By this stage the architectural choir, transept and first two bays of the nave at least were

presumably complete, including both the high altar and liturgical choir in the nave. The church was apparently consecrated in 1121 (Thurlby 2003), at which date the first iteration of the nave would almost certainly have been finished. With the exception of repairs conducted after the fire of 1178, there were no major works on the nave until the mid-fourteenth century (Morris and Thurlby 2003). From c. 1280 onwards a series of ambitious new revaulting projects were initiated, starting with the choir. By c. 1350 the vaulting in the central vessels of the choir, transept crossing and nave had all been replaced by lierne vaults of remarkable complexity.

Whereas the majority of scholars have focused exclusively on the high vaults at Tewkesbury, comparatively little attention has been expended on the adjoining aisles. Though the exact date of the nave aisle vaults is not known, it was probably somewhere in the region of c. 1335-49 – the date range ascribed to the main vault above (Morris 2003). The unusual form and structure of these vaults was the product in part of its relationship with the existing fabric. The eleventh-century walls, piers, responds and arcade arches were all retained, with the springing levels of the ribs on the window side of the bays being slightly lower than those on the arcade side – a common feature in eleventh-century aisle construction. The semi-circular form of the arcade arches is repeated in the curvature of the adjoining ribs, but the wall ribs on the window side are significantly lower, taking the form of a depressed segmental arch. The apexes of these wall ribs are connected to the crown of the vault by an unusual ridge rib constructed as a segmental half-arch. Such a design might have been intended to reflect the form and structure of the previous iteration of the aisles (Figure 3), which may have been covered by a half barrel vault (Thurlby 2003). Evidence for this is provided by both the masonry breaks visible in the outer walls and the half arches marking the transition between the transept and nave aisles. The apexes of the pointed arches of the transverse ribs on the east and west sides of the fourteenth century vaults are positioned along the curvature defined by these half arches. This provides the level for the crown of the vault and its corresponding horizontal ridge rib, which is slightly higher than the level of the arcade wall ribs. The diagonal ribs were constructed as segmental arches, with slight irregularities resulting from the different springing levels that they span.



Figure 3. Tewkesbury Abbey, south nave aisle, bay S12, tentative reconstruction of eleventh-century vault.

The unusual form of the ribs is further exacerbated by their corresponding webs. Those immediately flanking the longitudinal ridge rib represent an approximately horizontal tunnel from east to west. Their masonry is mostly fairly conventional, consisting of courses laid roughly parallel to the ridge, but the stones used are highly irregular in shape and size and in some bays the direction of the coursing switches towards the ridge, their stones lying perpendicular to the lower courses (Figure 8). A similar approach can also be seen in the webs directly abutting the arcade, where the tunnel and ridge rib have a slight upwards incline towards the crown of the vault. However, the webbing on the

window side is unusual, with few parallels in English vaulting. Whereas on the other sides the webs each correspond to two distinct rib curvatures, on the window side they each correspond to three: a wall rib, a diagonal and a curved ridge rib. The result is a bulging surface produced by a highly irregular and improvised pattern of stonelaying, with every web being constructed using a unique and ad hoc set of courses.

3 QUANTIFICATION AND ANALYSIS

The principal problem which our project encountered in the aisles at Tewkesbury was how to quantify such curvatures and the stonelaying practices which produced them. Before this point the digital techniques which we had developed were exclusively focused on analysing rib geometries, following the principle established by the nineteenth-century scholar Robert Willis (1842) that ribs were the defining elements of a vault's three-dimensional form. Surveys were conducted using digital laser scans taken at strategic points in each of our case study sites, creating detailed point cloud models made up from hundreds of thousands of individual measurements. These were then converted into mesh models which could be imported into Rhinoceros, an advanced 3D modelling program. The software was then used to trace the intrados lines of each rib in three-dimensions, producing a wireframe model of best fit curves. These lines enabled us to quantify the vault's design by extracting data which could be analysed geometrically, including distances, proportions, positions of centres and radii. Such data allowed us to investigate the geometrical methods which could have been used to lay out each rib, enabling us to produce informed hypotheses regarding the design processes of the vaults themselves. However, the techniques which we developed for ribs were not applicable to the webbing. Rather than being conceived using two-dimensional curvatures arranged in three-dimensional space, webs present a fully three-dimensional curvature created by patterns of stonelaying, with the orientations and positions of each block gradually giving shape to the structure as a whole. Consequently, it was necessary to develop a new set of techniques to quantify and analyse the masonry surface.

The first method which we attempted involved using contours (Figure 4). Derived from topographical mapping, this technique quantifies the gradient of a slope in terms of the change in height, visualised from a single two-dimensional plane. In Rhinoceros we used the 'contour' command to take horizontal sections of the mesh models at regular vertical intervals, defining the starting plane as well as the direction and distance between the sections. Viewed from a direction perpendicular to the starting plane, the result is a pattern of two-dimensional lines which describe the three-dimensional structure of the vault, with the changing gradient of its surface being given by the distances between the contours.

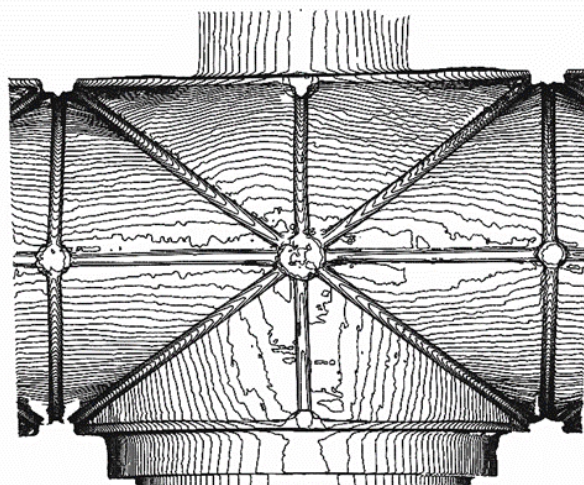

Figure 4. Tewkesbury Abbey, bay N8, contours.

The starting plane can be aligned in any orientation, allowing several different types of contour to be generated. The most versatile and straightforward of these is produced by aligning the direction of contours perpendicular to the base of the model. Viewed from the top down, this produces a plan of the vault analogous to a topographical map (Figure 4). Alternatively, the contours can be aligned perpendicular to the longitudinal or transverse axis of the model (Figure 5). Rather than displaying changes in gradient, these contours show changes in curvature, allowing us to assess whether or not the webs are horizontal tunnels or other more rounded forms. Yet whilst contours can give an impression of the overall three-dimensional form of the webbing, they do not show how that shape was constructed, nor do the resulting lines give any indication of how the individual stones were laid.

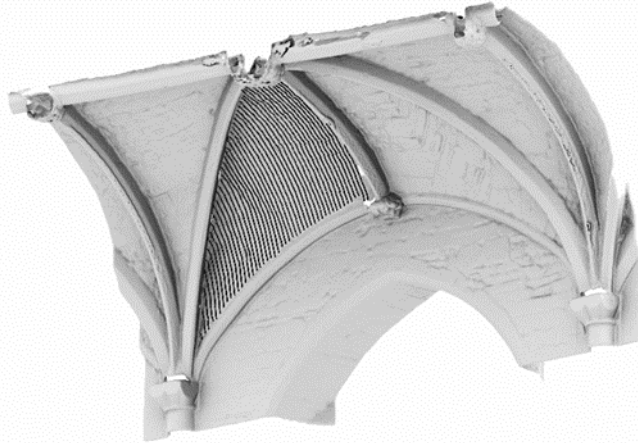

Figure 5. Tewkesbury Abbey, bay N8, contours (parallel to transverse axis) superimposed on mesh model.

The latter point can be demonstrated through a process which we have called course tracing. This is conceptually similar to the tracing methods we have adopted for rib intrados lines, using the tools available in Rhinoceros to record the lines of the courses on a stone by stone basis. Lines were drawn over the mesh model from a viewpoint perpendicular to the transverse axis of the vault. Though initially we attempted to trace the lines of the mortar joints, we soon discovered that these were extremely difficult to identify owing to the limited fidelity of the mesh model and its surface texture. Instead we found that the centreline of the courses was a more reliable alternative, following the midlines of the exposed faces of the individual stones. Once these lines were in place, the 'project' command was used, an operation which automatically extrudes the polyline in a direction perpendicular to the selected viewport and plots its points of intersection with the mesh surface. Excess lines were removed using the 'Delete' and 'Trim' commands and the results tested against the model, with the original set of lines being adjusted and the projection repeated where required to improve accuracy. For the upper parts of the webs it was necessary to switch to a top-down viewpoint, as it was otherwise difficult to record the courses with any degree of precision. The resulting course tracings could then be overlaid directly onto the contours, allowing the two methods to be compared directly (Figure 6). In the nave aisles at Tewkesbury, there is a significant difference between the lines of the coursing and of the contours, especially webs adjoining the window side. Consequently, it follows that contours are not particularly useful for analysing the vault's construction, as they relate more closely to the results of the stonelaying process than its underlying methods. Yet whilst course tracing can circumvent this to a degree, its limited accuracy is potentially problematic. Not all courses can be identified or differentiated easily, even with the aid of photographs, surface textures or orthographic representations. Sometimes the gaps between courses are only visible when the digital model is viewed at oblique angles, making it difficult to locate the centreline precisely for tracing purposes. Furthermore, unlike our rib tracings the resulting wireframes are not the product of quantitative data, but rather a qualitative process of interpretation based on careful observation and intuitive draughtsmanship. The result is closer to a

visual record of an investigative process than a means of extracting precise analytical data, providing a structured means of visual analysis that encourages close observation of the vaults and their masonry.

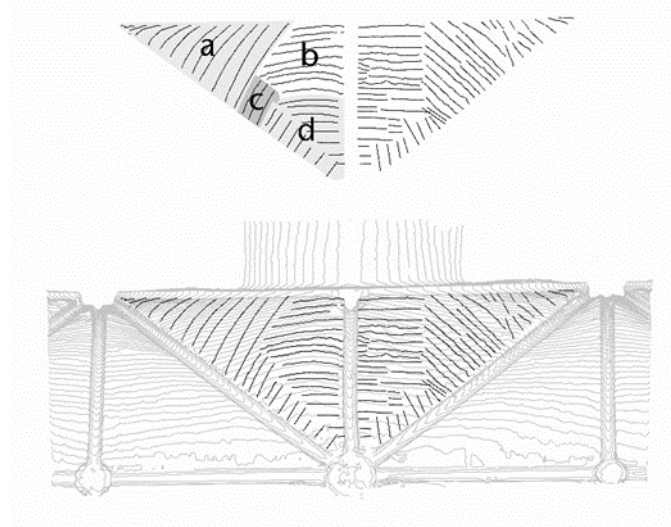

Figure 6. Tewkesbury Abbey, bay N8, course tracing (black) superimposed on contours (grey).

An alternative method which we attempted was height mapping. This is a method of indicating the differences in height across the surface of the vault using a graduated change in colour. This was accomplished using a script written using Grasshopper, a plug-in for Rhinoceros which uses an advanced visual programming language as a parametric design tool. Mesh models are a polygonal surface consisting of tens of thousands of triangular facets, forming a mesh of lines connecting individual points or vertices. Our script deconstructed the mesh into these vertices and extracted the z component of their coordinates within Rhinoceros, giving a numerical value for the height of each vertex. Each point was then mapped automatically onto a colour gradient extending from black (top) to white (bottom), producing a new texture which was then overlaid onto the surface of the model (Figure 7). The resulting height maps were effectively a means of displaying an infinite series of contours on the same image, with the rate of change in colour being proportionate to the gradient of the slope beneath. However, whilst it does provide a greater density of information than contours, it is ultimately subject to the same limitations. The structure of the masonry could not be revealed by a measurement of height alone. Instead what was required was a vector quantity rather than a simple magnitude, indicating not the position of each point on the model, but its orientation within three-dimensional space.

In order to achieve such an analysis, we developed a method which we have called normal vector mapping. Within Rhinoceros, the orientation of each of the faces on the mesh model is expressed in terms of a vector with a total magnitude of one arbitrary unit, its direction perpendicular (or 'normal') to its respective surface. These 'normal vectors' are the numerical equivalent of an angle in three-dimensional space, defined in terms of three components: x, y and z. The relative magnitude of these components is determined trigonometrically by the formula $x^2 + y^2 + z^2 = 1$, with the values of each ranging between -1 and 1. Through extracting these normal vectors from the model, we were able to produce a set of locally determined values for the orientation of its faces which are entirely independent from their respective heights. Isolating a single component of these vectors allowed us to measure the flatness of the mesh faces with respect to a specific cardinal direction (north, south east or west). Within a room modelled as a simple cube, the flat ceiling (facing downwards) would possess an (x, y, z) value of (0, 0, -1). The level floor (facing upwards) would possess a value of (0, 0, 1) and the walls (facing inwards) a z component of 0, with the north wall

represented by $(0, -1, 0)$, the south wall $(0, 1, 0)$, the west wall $(1, 0, 0)$ and east wall $(-1, 0, 0)$. Alternatively, if the room had a ceiling sloping upwards from east to west at an angle of 45° , then its surface would possess a y component of 0, an x component of $-\sqrt{0.5}$ and a z component of $-\sqrt{0.5}$, resulting in a value of $(-0.707, 0.000, -0.707)$ to three significant figures.

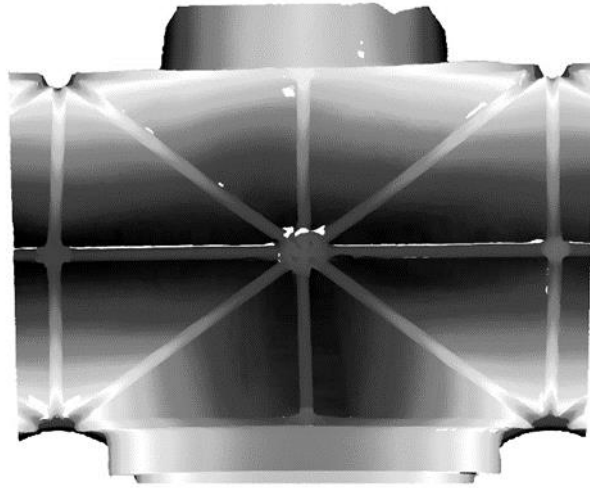

Figure 7. Tewkesbury Abbey, bay N8, height map.

As in the case of height mapping, we were able to use a Grasshopper script to extract the individual components of the normal vectors automatically and position them on a colour gradient that could be overlaid directly onto the mesh model (Figure 8). If the z component is isolated, the resulting texture relates the changing slope of the vault surface from block to block, the shade assigned to each face indicating how close its gradient is to that of a flat ceiling (-1, black), wall (0, grey) or floor (1, white). As the stones used in webbing are usually straight oblongs, the majority of the faces on each surface will share a similar orientation and therefore colour, giving a clear indication of how the orientations of stones change both from course to course and within the courses themselves. This illustrates how the curvature of the webbing was shaped on a stone-by-stone basis, allowing the three-dimensional form of its masonry to be analysed in an unprecedented level of detail.

At Tewkesbury, the results of these methods can be seen by focusing on a specific example, in this case the third bay from the transept in the north aisle (henceforth N8). Using a Z component map, it is possible to see that there is a fairly uniform gradient in the longitudinal tunnel (Figure 8). Though the angles of the courses approach being parallel to the ridge as they rise, at the base they are bent slightly inwards, a phenomenon called ploughsharing which is caused by the difference in curvature between the diagonal and transverse ribs. However, the webs abutting the wall on the window side are quite different. Rather than being uniform, the shades of several of the courses gradate from stone to stone, indicating that the coursing itself is cambered. This can be further illustrated through course tracing, which shows many of the courses of stones being laid on a distinctly curved path. Considered as a whole, the effect of this approach is similar to that of the horizontal tunnel in gradient, but with a subtle difference that is revealed by isolating the other components of the normal vector. A Y component map shows that the gradient respective to the central ridge is slightly offset from those in the longitudinal tunnels, flattening more rapidly towards the apex in a circular rather than linear pattern (Figure 9). This is further illustrated by the X component map, which indicates a slight bowing outwards in the longitudinal direction towards the lower half of the web (Figure 10). The net result of these observations is a slight bulging of the vault as it rises, the three-dimensional curvature corresponding to the cambering of its component courses. This can also be seen in contours taken from a plan view, which show an increasingly curved profile as they rise towards the vault's crown.

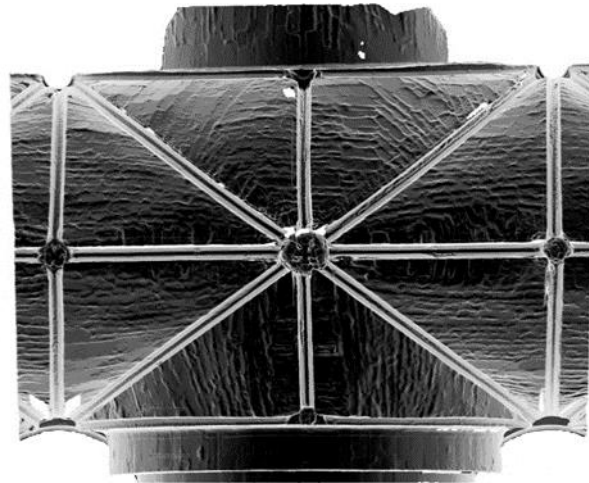

Figure 8. Tewkesbury Abbey, bay N8, normal vector map, Z component.

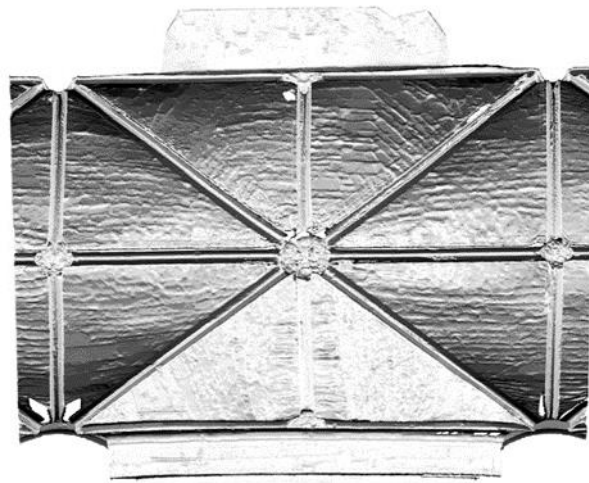

Figure 9. Tewkesbury Abbey, bay N8, normal vector map, Y component.

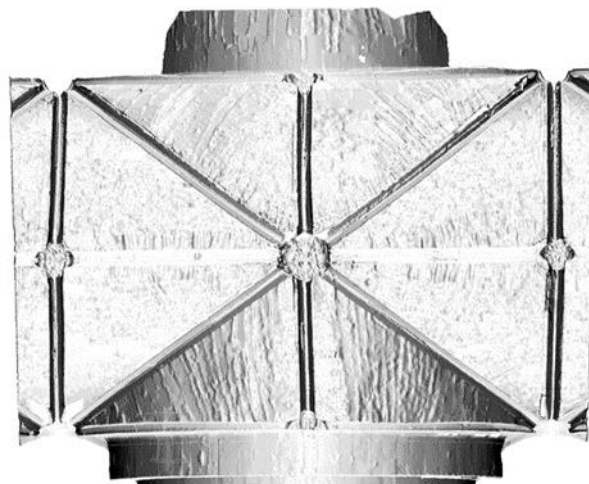

Figure 10. Tewkesbury Abbey, bay N8, normal vector map, X component.

4 CONSTRUCTION

It has traditionally been assumed that some kind of formwork was used for setting out the webbing of the nave aisle vaults at Tewkesbury. The first possibility is an arrangement similar to that which survives in the octagonal fourteenth-century bell tower of the church at Lärbro on Gotland, which features a set of wooden flats stretching between the framework for the ribs. This could have been further augmented by a layer of mason's earth above acting as a bedding surface for the stones, a method which was employed for the vaults at Troyes Cathedral during the fifteenth century (Murray 1987). However, there is no known example of this technique being used in England. It is possible that mortar was used in a similar way instead, as the marks left behind by centering of this type can still be seen in several buildings, though this could also have been caused by seepage from the rubble and mortar infilling above. Whilst these marks tend to be found in earlier examples of English vaulting, it is possible that this practice was more widespread than can be accounted for, as in most cases such evidence would have been concealed by later layers of plaster. An alternative method has been proposed by Malcolm Thurlby who suggested that flexible wattle surfaces might have been used to give shape to the webbing, a method evidenced both by mortar markings and remaining fragments in several other English sites (Thurlby 2004).

The key question, however, is whether such formwork would actually have been necessary at Tewkesbury. Robert Willis (1842) and Eugène-Emmanuel Viollet-le-Duc (1854-68) both argued that the cambered surfaces would be sufficient to be self-supporting, citing the theory developed by the architect Johann Claudius von Lassaulx (1830-31). This idea has been further developed by David Wendland (2007), who has demonstrated it using a combination of geometrical analysis and physical modelling. Could something similar have taken place in the vaults at Tewkesbury? If so, was this the reason why the coursing was so complex?

On the window side webs of bay N8 at Tewkesbury, the lower set of courses are laid diagonally, following a curved path extending from wall rib to diagonal (Figure 6). In the northwest cell of webbing this continues for fourteen layers (see a on Figure 6), after which a new set of horizontal courses is laid with a slight curvature (b). The first six extend from the curved ridge rib to the edge of section below, but the subsequent three layers are raked back, producing a stepped masonry break. The gap between these coursings and the diagonal rib are filled by a further three courses, laid at a slanting angle and resting on the exposed faces of the horizontal courses below (c). The horizontal courses then resume and the pattern repeats, the masons having alternated between horizontal and diagonal courses until the remaining space between the ribs was knitted together (d). This approach was used for almost all of the nave aisle vault at Tewkesbury, with minor variations from bay to bay. In some bays, the uppermost sets of diagonal courses were omitted, the top set of horizontal layers instead resting directly on the vault's diagonal ribs. Similarly, in bay S12 the beginning of the horizontal courses is much closer to the springing point than in the other bays, creating a haggled edge to the masonry where it abuts the wall ribs. Rather than adopting a uniform method of construction, the builders of these vaults adopted a shared body of principles that could be variously mixed, matched, omitted or repurposed to suit the peculiar demands presented by each bay. The reason for the changing directions in the coursing may have been a combination between mediating the shape of the web's three-dimensional curvature whilst ensuring that the masonry remained self-supporting. Initially, the gap between diagonal and wall rib was small enough for the courses to be supported, with the switch to horizontal courses occurring at the point where the masons feared their overbalancing. This mode of coursing was then continued for a few layers before a new set of diagonal courses was used to lock them into place, the alternating pattern being essential to maintain the vault's stability during construction. The differences from bay to bay can be ascribed both to the variability of the sizes of the available stone blocks and the level of confidence of the stonemasons, with the decision to switch courses being made individually on an ad hoc basis. Some evidence for this can be found in the window side webs of bay S7, which features a unique

masonry pattern in which only diagonal courses were used. For whatever reason, the masons in this case were confident of the stability of the courses throughout the erection process.

5 CONCLUSIONS

On the basis of the stonework alone, it seems possible that at least some of the webs in the nave aisles at Tewkesbury could have been constructed without supporting formwork. The cambered surface of the courses and the pattern of their changing directions suggest not random placement, but a careful, if improvisational, attempt to ensure stability during the construction process by following a set of shared principles. However, it is not absolutely certain that no formwork was used, and further testing would be required before any definite conclusions can be drawn.

The next phase for our research will be to use the data gathered during our modelling process for structural analysis. Dimensions, positions and orientations of the stones will be used for piece-by-piece numerical simulation of the construction process, enabling us to analyse whether or not the webbing could support itself as each course was laid. Estimates for the shape and structure of the stones beneath the surface of the webbing will be provided by comparative study of ruined or partially deconstructed vaults at other sites, as well as reference data relating the material properties of the stone and mortar. This numerical model will then be validated using small scale construction experiments of parts of the vault, allowing us to test whether our theoretical modelling could work in practice.

Even if such a modelling process is ultimately inconclusive, the form of the masonry at Tewkesbury has far wider implications for the study of medieval design and construction processes. The cambered surfaces of the webbing indicate that their form was not solely defined by the geometry of the surrounding ribs. Instead, the stonelaying process itself was integral to the conception of the vault's three-dimensional form, constituting as much a process of active design as passive realisation. The coursing produced by the masons at Tewkesbury does not give the impression of meticulous planning, but instead an intuitive grasp of masonry mechanics which could be adapted to any vaulting surface. Whilst the form of the window side webs have few if any parallels in English vaulting, it is possible that the same ad hoc approach was more widespread. With the webbing of the overwhelming majority of comparable vaults being concealed by plaster or whitewash, there is no way of knowing how many other sites made use of multidirectional coursing to achieve their three-dimensional forms. Whether it was constructed using formwork or not, the form of the nave aisle vaults at Tewkesbury offer a challenge to our conception of medieval vaulting techniques, both within England and beyond.

ACKNOWLEDGEMENTS

The research contained in this paper would not have been possible without the efforts of JR Peterson and Sarah Duffy (University of Liverpool, Liverpool, UK), who helped to gather and process the data. We would also like to acknowledge the invaluable contributions of Jenny Alexander (University of Warwick, Coventry, UK), Han-Mei Chen (University of Liverpool), Stuart Harrison (University of York, York, UK) and Richard Plant (Christie's Education, London, UK), who advised us during the research process.

REFERENCES

- Buchanan, A. C. & Webb, N. J. 2017a. Tracing the past: A digital analysis of Wells cathedral choir aisle vaults. *Digital Applications in Archaeology and Cultural Heritage* 4: 19-27.
- Buchanan, A. C. & Webb, N. J. 2017b. Creativity in Three Dimensions: An Investigation of the Presbytery Aisles of Wells Cathedral. *British Art Studies* 6.
- Buchanan, A. C. & Webb, N. J. 2018. Two- and three-dimensional geometry in Tierceron vaults: A case study of Exeter cathedral. In I. Wouters, S. van de Voorde, I. Bertels, B. Espion, K. de

Jonge and D. Zastavni (ed.), *Building Knowledge, Constructing Histories: Proceedings of the 6th International Congress on Construction History (6ICCH 2018)*, July 9-13, 2018, Brussels, Belgium: 391-97. CRC Press, London.

Buchanan, A. C. & Webb, N. J. 2019. Digitally aided analysis of medieval vaults in an English cathedral, using generative design tools. *International Journal of Architectural Computing* 17(3): 241-59.

Lassaulx, J. C. de 1830-31. Description of a mode of erecting light vaults over churches and similar spaces. *Journal of the Royal Institution of Great Britain* 1: 224-40.

Morris, R. 1974. *Tewkesbury Abbey: the Despencer Mausoleum*. *Transactions of the Bristol and Gloucester Archaeological Society* 93: 142-55.

Morris, R. 2003. *The Gothic Church: Vaulting and Carpentry*. In R. Morris & R. Shoesmith (ed.), *Tewkesbury Abbey: history, art and architecture*: 131-42. Logaston Press: Almeley.

Morris, R. & Thurlby, M. 2003. *The Gothic Church: Architectural History*. In R. Morris & R. Shoesmith (ed.), *Tewkesbury Abbey: history, art and architecture*: 109-30. Logaston Press: Almeley.

Murray, S. 1987. *Building Troyes Cathedral: The Late Gothic Campaigns*. Indiana University Press: Bloomington and Indianapolis.

Pacey, A. 2007. *Medieval Architectural Drawing: English Craftsmen's Methods and their Later Persistence (c.1200-1700)*. Tempus, Stroud.

Thurlby, M. 2003. *The Norman Church*. In R. Morris & R. Shoesmith (ed.), *Tewkesbury Abbey: history, art and architecture*: 131-42. Logaston Press: Almeley.

Thurlby, M. 2004. *The Use of Tufa Webbing and Wattle Centering in English Vaults down to 1340*. In M. T. Zenner, (ed.), *Villard's Legacy: Studies in Medieval Technology, Science and Art in Memory of Jean Gimpel*: 157-72. Farnborough, Ashgate.

Viollet-le-Duc, E.-E. 1854-68. *Dictionnaire raisonné de l'architecture française du XIe au XVIe siècle*. 10 vols. B. Bance and A. Morel, Paris.

Wendland, D. 2007. *Traditional Vault Construction Without Formwork: Masonry Pattern and Vault Shape in the Historical Technical Literature and in Experimental Studies*. *International Journal of Architectural Heritage Conservation, Analysis and Restoration*, 1(4): 311-65.

Willis, R. 1842. *On the Construction of the Vaults of the Middle Ages*. *Transactions of the Royal Institute of British Architects* 1(2): 1-69.