

End of Project Report

RMIS No. 4679

AN EVALUATION OF EARTH-BANKED TANKS FOR SLURRY STORAGE

Authors

Heather Scully, Timothy Gleeson, Patrick J. Purcell, Edward G.
O'Riordan, Mike Long, Séamus Crosse

Beef Production Series No. 53

Grange Beef Research Centre
Dunsany
Co. Meath

ISBN 1 84170 465 2

September 2006

TABLE OF CONTENTS

SUMMARY	7
INTRODUCTION	8
LITERATURE REVIEW	9
EXPERIMENT 1: SOIL CLASSIFICATION TESTS	10
Introduction.....	10
Natural moisture content	10
Particle size distribution (PSD).....	10
Atterberg limits.....	11
Permeability.....	11
Results.....	12
Natural moisture content	12
Particle size distribution.....	13
Atterberg limits.....	13
Permeability.....	14
Discussion	14
Conclusions	19
EXPERIMENT 2: SOIL PLACEMENT AND MOISTURE CONTENT VARIATION TESTS	20
Introduction.....	20
Compactive effort	20
Compactive effort variation.....	21
Moisture content variation	21
Results and discussion.....	21
Conclusions	26
EXPERIMENT 3: SOIL/SLURRY TESTS	27
Introduction.....	27
Modified SRF test.....	27
Results and discussion.....	29
Discussion	32
Conclusions	33
EXPERIMENT 4: FULL-SCALE FIELD TESTS	34
Introduction.....	34
Full-scale earth-banked tank	34
Tank measurements.....	35
Results.....	36
Groundwater quality	36
Water level data.....	37
Slurry infiltration measurement.....	38
Discussion and conclusions	39
EXPERIMENT 5: PILOT-SCALE FIELD TESTS	40
Introduction.....	40
Design of pilot-scale earth-banked tank	40
Construction of pilot-scale earth-banked tank.....	40
Slurry infiltration and effluent quality measurement.....	41
Discussion	42
Conclusions	43
EXPERIMENT 6: DEVELOPMENT OF A SLURRY SOIL MODEL	44
Introduction.....	44
Flow hydraulics.....	44
Model development	45
Falling head	45

Constant head	46
Rising head.....	46
Model equations	47
Preliminary model validation.....	48
Introduction.....	48
Materials and methods	48
Results.....	50
Worked example.....	53
Discussion and conclusions	56
CONCLUSIONS.....	58
Literature review	58
Laboratory experiments.....	58
Field work	58
Modelling work.....	58
General.....	59
REFERENCES.....	60
APPENDIX A: PUBLICATIONS	62
AFTERWORD	63

LIST OF TABLES

Table 1: Natural moisture content (NMC) test results	12
Table 2: Selected particle size distribution results for soil samples.....	13
Table 3: Summary of Atterberg limit tests	13
Table 4: Properties of triaxial permeability test soils	14
Table 5: Effective size, uniformity coefficient and curvature coefficient for soil samples	14
Table 6: Computed Hazen soil permeabilities for test soils.....	15
Table 7: Relative consistency and liquidity index of soil samples	15
Table 8: Typical relative consistencies and liquidity indices.....	16
Table 9: Some regulatory Atterberg limits for clay liners	16
Table 10: Some regulatory limits for coefficient of permeability	17
Table 11: Compactive effort applied to each soil sample	21
Table 12: Results for Moorepark compaction variation permeability tests	22
Table 13: Results for Dublin till compaction variation permeability tests.....	22
Table 14: Results for Grange compaction variation permeability tests	22
Table 15: Results for Moorepark moisture content variation permeability tests	23
Table 16: Results for Dublin till moisture content variation permeability tests.....	23
Table 17: Results for Grange moisture content variation permeability tests	24
Table 18: Results for Carlow moisture content variation permeability tests	24
Table 19: Soil properties to achieve hydraulic conductivity of 1×10^{-9} m/s compared with results for four soils investigated (adapted from Benson et al. 1994)	26
Table 20: Total solids content of three test suspensions.....	48
Table 21: SRF 'r' values for test suspensions	50

LIST OF FIGURES

Figure 1: Soil sampling locations.....	10
Figure 2: Atterberg limits and related indices (Lambe and Whitman 1979).....	11
Figure 3: Particle size distribution curve for soil samples.....	13
Figure 4: Atterberg limit results plotted on Plasticity Chart.....	17
Figure 5: British Standard one-Litre compaction mould (Head 1997).....	20
Figure 6: Rammer for British Standard 'light' compaction test (Head 1997).....	20
Figure 7: Variation in bulk density for each soil subjected to varying compactive efforts.....	22
Figure 8: Variation of coefficient of permeability with bulk density under varying compaction levels.....	23
Figure 9: Variation of coefficient of permeability with moisture content.....	24
Figure 10: (a) SRF apparatus and (b) Modified SRF apparatus.....	27
Figure 11: Modified SRF apparatus.....	28
Figure 12: Slurry flow through laboratory filter paper.....	29
Figure 13: Slurry flow through Leighton-Buzzard sand using modified SRF apparatus.....	29
Figure 14: Effective permeability of Leighton Buzzard sand due to progressive sealing by slurry.....	30
Figure 15: Effective permeability of Leighton-Buzzard sand due to progressive sealing by cattle slurry (logarithmic scale).....	31
Figure 16: Reduction in flow rate through Leighton-Buzzard sand under the application of cattle slurry of varying total solids contents and constant pressure of 0.5 bar.....	31
Figure 17: Flow rate through Leighton-Buzzard sand for waterworks sludge of varying total solids contents under a constant pressure of 0.25 bar.....	32
Figure 18: Grange earth-banked tank after emptying (2001).....	34
Figure 19: Compacted subsoil liner.....	35
Figure 20: Plan view of tank and borehole locations.....	35
Figure 21: Grange research station meteorological site (inset shows control boreholes).....	36
Figure 22: Full-scale earth-banked tank and meteorological site groundwater quality.....	37
Figure 23: Water levels in aquifer for boreholes 8A, 4B and 2C.....	38
Figure 24: Monthly rainfall, class A pan evaporation and tank level changes.....	38
Figure 25: Sections through pilot-scale earth-banked tank.....	41
Figure 26: Slurry infiltration rate through base of pilot-scale earth-banked tank.....	41
Figure 27: Effluent quality from pilot-scale earth-banked tank.....	42
Figure 28: Flow of a suspension through a semi-permeable membrane.....	45
Figure 29: Graphical representation of seepage rate for rising, constant and falling head.....	47
Figure 30: Schematic of experimental apparatus.....	49
Figure 31: Experimentally derived and calculated flow rates for suspensions A, B and C.....	52
Figure 32: Profile through earth-banked slurry storage tank.....	53
Figure 33: Calculated seepage rate through suspension cake without soil liner.....	54
Figure 34: Calculated seepage rates from earth-banked slurry tank.....	56

LIST OF EQUATIONS

Equation 1 Plasticity index equation.....	11
Equation 2 Darcy's Law.....	11
Equation 3 Hazen soil permeability equation	15
Equation 4 Relative consistency equation.....	15
Equation 5 Liquidity index equation.....	15
Equation 6 Darcy's law (using different notation from Equation 2).....	18
Equation 7 Specific discharge equation	18
Equation 8 Flow decay equation for slurry through Leighton Buzzard sand	30
Equation 9 Falling Head	47
Equation 10 Constant Head	47
Equation 11 Rising Head.....	47

SUMMARY

This study examines the feasibility of using earth-banked tanks (EBT's) as an alternative and economical means of winter storage for animal and other farmyard wastes. The study contains a detailed literature review on the subject, the results of a series of laboratory-scale experiments, field studies and a predictive model of the transport process through the soil liner of an earth-banked tank.

For the laboratory studies, soils were sampled at four different locations throughout Ireland. These soils were subjected to soil classification and hydraulic conductivity tests. Since this series of experiments had been conducted using water as the permeating fluid, further investigation was undertaken to examine the effect of animal slurry flowing through a soil liner. It was concluded that the presence of suspended solids in the slurry had a pronounced sealing effect on the soil liner, significantly reducing the effective permeability of the soil due to the deposition of solids on the soil surface and within the pores of the soil.

An investigation of a full-scale earth-banked tank at the Teagasc Grange Beef Research Centre at Dunsany, Co. Meath was undertaken. Groundwater quality, groundwater level and slurry infiltration rates were monitored after the tank was filled with animal slurry. As a result of the monitoring programme, it was concluded that well-constructed earth-banked tanks could successfully store animal slurry and that the quality of the groundwater around the tanks was well within permissible limits post filling and compared favourably with the groundwater quality prior to the installation of the tanks. A novel methodology for measuring infiltration rates through a subsoil liner and sampling groundwater quality from directly beneath the subsoil liner of an earth-banked tank was developed. A pilot-scale tank was constructed which enabled direct sampling of the quality and measurement of the quantity of the permeate from the tank. The slurry infiltration rate was significantly below acceptable limits and declined with time, indicative of a sealing of the pores of the soil due to the deposition of bio-solids. Examination of groundwater quality data in the vicinity of the pilot-scale earth-banked tank showed no discernible deterioration in quality.

A mathematical model of the soil sealing due to the physical transport of suspended solids contained in the animal slurry through the soil liner is presented. The model describes the following hydraulic conditions: falling head, constant head and rising head. The model was validated for the falling head case using suspensions of cattle slurry at three different total solids concentrations. The proposed model may be useful to regulatory authorities, enabling an estimate of the likely soil sealing by suspensions flowing through soil liners to be made.

The overall conclusion of the study is that well-constructed earth-banked tanks using suitable soil that is adequately compacted can be successfully used to temporarily store highly polluting liquids such as animal slurries. The enhanced slurry-storage capacity resulting from the use of earth-banked tanks should reduce the pressure on farmers to spread slurry on land at inappropriate times, thereby contributing to an improvement in the quality of watercourses adjacent to agricultural activities.

INTRODUCTION

Earth-banked tanks have been used worldwide for many years. The literature clearly shows that in most cases, they work extremely well when constructed in an appropriate manner. The single most important component of an earth-banked tank (EBT) is the soil used in its construction. The soil has many roles in the EBT; it forms the embankments which provide depth and stability to the tank, it acts as a barrier between the underlying bedrock and the tank, it acts as a filter adding an extra measure of protection to groundwater, it is used to form an impermeable barrier between the liquid contained in the tank and the underlying environment and it also forms a seal when combined with the solids deposited from the contained fluid. Therefore, it is vital that prior to any EBT being constructed, a site investigation be carried out which will allow the soil type and depth to be analysed, thereby ensuring that the finished tank will benefit both the farmer and the environment. This study is concerned with evaluating EBT's by reviewing the literature on their performance and also by conducting laboratory and field studies to examine the suitability of using EBT's for animal slurry storage in Ireland.

LITERATURE REVIEW

Research conducted on full-scale EBT systems showed that seepage rates from the tanks decreased over time which suggested the formation of a seal along the inner faces and at the base of the tanks. The measurement of very small changes in slurry level over large areas presented difficulties due to the formation of a surface crust in some cases, and wind effects in other instances (Glanville et al. 2001). Evaporation measurements were also problematic since evaporation measurements taken from class A pans filled with water were not readily applicable to evaporation from large open bodies of slurries, some with crust formations (Ham 2002).

Groundwater monitoring studies were conducted by many researchers to compare post-construction groundwater quality with background values. In some cases, results had to be discounted due to suspected outside influences on the groundwater quality (Nordstedt et al. 1971). Researchers found that on new sites, groundwater concentrations of some chemical constituents did increase immediately after the tank was put into operation but that within a very short period of time, these concentrations fell back to values at or near to the original levels. These results indicate that the tank was sealing over time. The soils underlying the tank and those used in tank construction appeared to have a marked effect on groundwater quality results, indicating that low permeability, well-graded soils afforded a high degree of protection to groundwater, although in one instance (Sewell 1978) even very sandy soils were recommended, whereas Westerman et al. (1995) showed that sandy soils were unsuitable for EBT's.

Small-scale laboratory studies were conducted by many researchers (Chang et al. 1974, Hills 1976 etc.). In these studies, animal slurry was applied to soil columns and hydraulic conductivities or slurry infiltration rates measured. In almost all cases, the slurry infiltration rate reduced markedly over time, indicating that a seal had formed between the slurry and soil.

The literature review clearly demonstrates that in most studies there was evidence of some seepage from earth-banked tanks immediately after installation, but that in most cases it was very low and that the rate of seepage reduced over time (Miller et al. 1985). The authors all agreed that this was due to the formation of a seal between the slurry and the soil. It is unclear however, whether this sealing effect can be attributed to physical, chemical or biological sealing processes. The research also showed that earth-banked tanks generally performed best when constructed in fine-grained soils, although some studies found that performance was independent of soil type (Culley and Phillips 1982).

The conclusions of the research review are:

- (i) earth-banked tanks constructed without the need for a compacted soil liner, can be used successfully, but only if there exists low permeability fine-grained soils beneath the tank invert. In these instances, the underlying soil is generally such that it has most or all of the properties of a soil liner without the need for re-working;
- (ii) the formation of a slurry-soil seal in an earth-banked tank significantly reduces the seepage rate from the tank over time. There is clear evidence of some physical sealing but more research is needed to examine the contribution of chemical and biological sealing to the overall reduction in infiltration;
- (iii) the soil used in earth-banked tank construction has an impact on the likely seepage rate from the tank and that soil texture and/or plasticity should also be considered in addition to hydraulic conductivity when a soil's suitability is being assessed.

EXPERIMENT 1: SOIL CLASSIFICATION TESTS

Introduction

A laboratory study was undertaken to evaluate the suitability of a number of Irish soils for use as natural soil liners in animal waste storage tanks. Four soils were selected from a number of locations around the country and were typical of those found throughout Ireland (see Figure 1). These soils were subjected to basic soil tests, normally conducted to characterise a soil. The soil tests are described below.

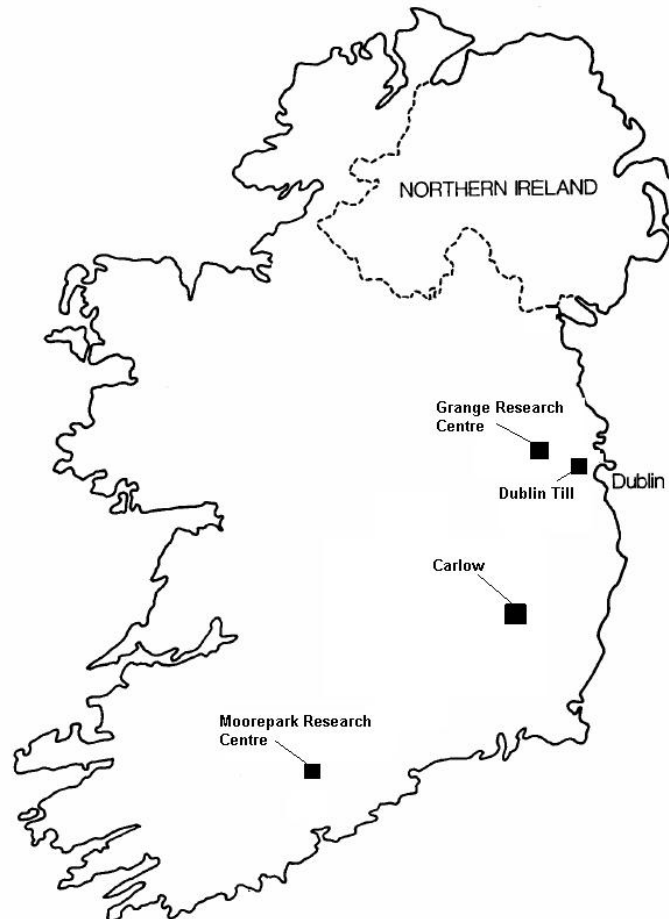

Figure 1: Soil sampling locations

Natural moisture content

The moisture content of a soil is defined as the mass of water which can be removed from the soil by heating to a temperature of 105 ° C expressed as a percentage of the dry mass. Natural moisture content (NMC) refers to the moisture content (w) of natural undisturbed soil in-situ.

Particle size distribution (PSD)

The particle size distribution (sieve and hydrometer analysis) test was carried out to quantify the fraction of sand, silt, and clay in each of the soil samples. A sieve was used to separate the gravel (particles coarser than 2 mm) from the grains less than 2 mm in diameter and the sand fraction was isolated by wet sieving through a set of nested sieves. The silts and clays in each sample were determined using a hydrometer that measured the density of a solution of silt and clay suspended in water.

Atterberg limits

Atterberg limits and related indices have become very useful characteristics of assemblages of soil particles. The limits are based on the concept that a fine-grained soil can exist in any of four states depending on its water content. A soil is solid when dry, and upon the addition of water proceeds through the semisolid, plastic, and finally liquid states, as shown in Figure 2. The water content at the boundaries between adjacent states are termed shrinkage limit (w_s); plastic limit (w_p); and liquid limit (w_L). The plasticity index (I_p) is defined by the following relationship:

Equation 1 Plasticity index equation

$$I_p = w_L - w_p$$

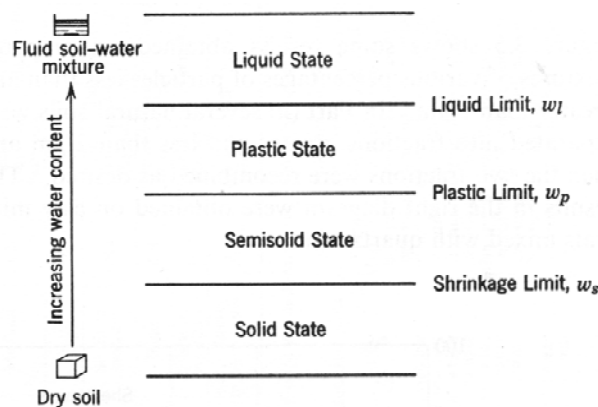

Figure 2: Atterberg limits and related indices (Lambe and Whitman 1979)

The liquid limit is determined by measuring the water content and the number of blows required to close a specific width groove for a specified length in a standard liquid limit device. The plastic limit is determined by measuring the water content of the soil when threads of the soil 3 mm in diameter begin to crumble. The shrinkage limit is determined as the water content after just enough water is added to fill all the voids of a dry pat of soil.

Permeability

In a soil, the voids are connected together and form continuous passageways for the movement of water brought about by rainfall, infiltration, transpiration by plants etc. When water falls on the soil surface, some of the water infiltrates the surface and percolates downward through the soil. This downward flow results from gravitational force acting on the water. Water within the voids of a soil is under pressure. This water, known as pore water, may be static or flowing. Water in saturated soil will flow in response to variations in hydrostatic head within the soil mass. Because the conduits of a soil are irregular and relatively small in diameter, it is necessary to consider average velocity of water through a given area of soil rather than specific velocities through particular conduits. Darcy (1856) further refined this assumption and showed that a fluid's velocity of flow through a porous medium could be directly related to the hydraulic gradient causing the flow (Equation (2)).

Equation 2 Darcy's Law

$$v = -Ki = K \frac{dh}{dz}$$

where:

v = the capillary velocity (m/s),
 i = hydraulic gradient (= dh/dz),

K = hydraulic conductivity (m/s),
h = total head (m),
z = elevation head (m).

The coefficient of permeability (k) is taken from Darcy's equation for fluid flow in soil and is defined as the rate of flow of water per unit area of soil when under a unit hydraulic gradient. The triaxial permeability test allows a flow of water through a soil sample to be maintained under a known difference of pressure, and the flow rate to be measured while the soil sample is subjected to a known effective stress. From these measurements, the soil permeability can be measured. It was decided to use the triaxial permeability test method for the four soils being assessed because of the following reasons:

- the sample is first saturated under the application of a back pressure which results in the reduction or elimination of flow problems due to gas bubbles. Saturation can also be achieved relatively quickly;
- the test can be carried out under effective stresses and at pore pressures which accurately reflect the in-situ soil conditions in the field;
- small rates of flow can be measured relatively easily which is important for this work since the achievement of low permeability is the goal;
- soils of intermediate permeability, such as silts, which are difficult to test by either the standard or falling head procedure, can be accommodated, as can clays.

Results

Natural moisture content

Location	CARLOW			DUBLIN TILL		
Sample No	1A	Date started	Jan-00	1	Date started	Jan-00
Relevant test	NMC	Operator	HS	NMC	Operator	HS
Sample No. and ref.		A	B		A	B
Container No.		3	15		103	12
Wet soil and container	g	90.15	84.32	g	89.67	82.64
Dry soil and container	g	77.58	71.24	g	83.15	75.91
Container	g	14.02	7.94	g	14.11	6.59
Dry soil	g	63.56	63.30	g	69.04	69.32
Moisture loss	g	12.57	13.08	g	6.52	6.73
MOISTURE CONTENT	%	19.78	20.66	%	9.44	9.71
AVERAGE MOISTURE	%	20		%	10	

Location	MOOREPARK			GRANGE		
Sample No	1	Date started	Jan-00	1B	Date started	Jan-00
Relevant test	NMC	Operator	HS	NMC	Operator	HS
Sample No. and ref.		A	B		A	B
Container No.		8	2		4	16
Wet soil and container	g	85.24	79.64	g	86.76	90.02
Dry soil and container	g	70.02	65.75	g	77.24	81.46
Container	g	8.95	9.44	g	12.03	14.57
Dry soil	g	61.07	56.31	g	65.21	66.89
Moisture loss	g	15.22	13.89	g	9.52	8.56
MOISTURE CONTENT	%	24.92	24.67	%	14.60	12.80
AVERAGE MOISTURE	%	25		%	14	

Table 1: Natural moisture content (NMC) test results

Particle size distribution

Results obtained from the particle size distribution tests carried out on the four soils are presented below in Figure 3 where the particle size is plotted on the horizontal axis and the cumulative percentage passing on the vertical axis. The horizontal axis is logarithmic to enable the full range of grading be clearly shown.

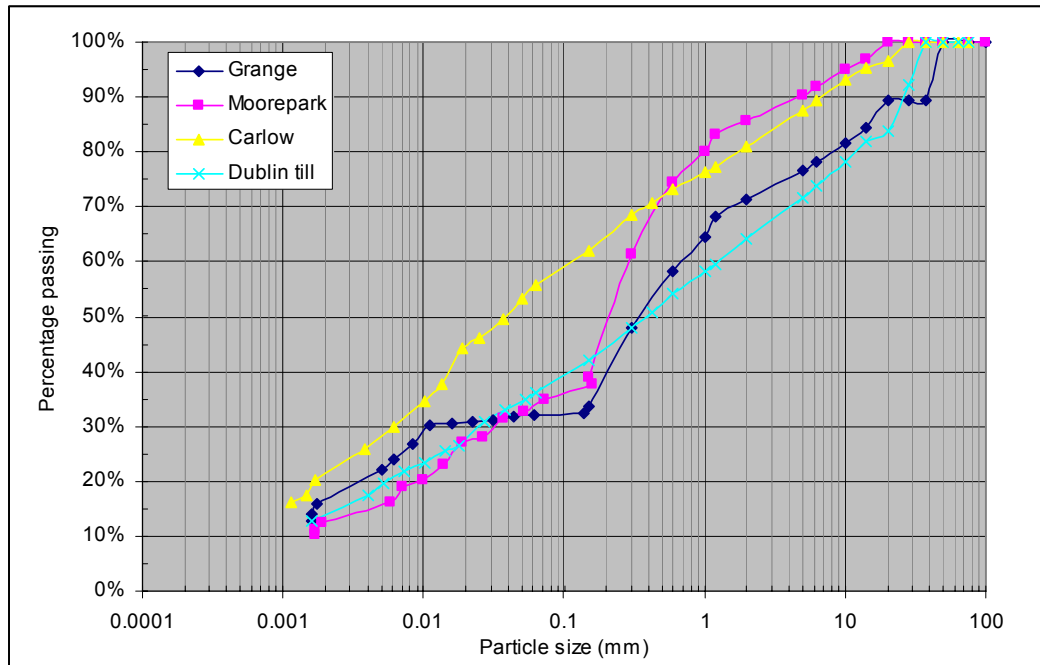

Figure 3: Particle size distribution curve for soil samples

SOIL SAMPLE	CLAY CONTENT %	FINES CONTENT %	SAND CONTENT %	GRAVEL CONTENT %
Grange	17	29	40	28
Moorepark	13	34	52	14
Carlow	22	56	24	19
Dublin Till	14	24	32	34

Table 2: Selected particle size distribution results for soil samples

Atterberg limits

SOIL SAMPLE	LIQUID LIMIT (W_L) %	PLASTIC LIMIT (W_S) %	PLASTICITY INDEX (I_P) %
Grange	32	17	15
Moorepark	24	13	11
Carlow	34	18	16
Dublin Till	26	14	12

Table 3: Summary of Atterberg limit tests

Permeability

DATA	UNITS	MOOREPARK	DUBLIN TILL	GRANGE	CARLOW
Coefficient of permeability	k (m/s)	2.21×10^{-9}	2.51×10^{-8}	2.74×10^{-9}	1.12×10^{-10}
Moisture content	%	24.95	8.90	14.49	23.21
Mass of solids	kg	1.101	1.49	1.451	1.249
Mass of water	kg	2.747	1.32	2.103	2.898
Sample volume	m ³	0.000702	0.000730	0.000744	0.000676
Volume of solids	m ³	0.000408	0.000552	0.000538	0.000462
Volume of voids	m ³	0.000294	0.000178	0.000206	0.000213
Saturation	S _r	0.93	0.74	1.02	1.36
Void ratio	e	0.72	0.32	0.38	0.46
Bulk density	(Mg/m ³)	1.96	2.22	2.23	2.28
Dry density	(Mg/m ³)	1.57	2.04	1.95	1.85

Table 4: Properties of triaxial permeability test soils

Discussion

The uniformity of a soil can be expressed by the uniformity coefficient (C_u), which is the ratio of D_{60} to D_{10} where D_{60} is the soil diameter at which 60% of the soil weight is finer and D_{10} is the corresponding value at 10% finer. The effective size (D_{10}), (D_{30}), (D_{60}), the uniformity coefficient (C_u) and the curvature coefficient (C_z) may be determined from Figure 3. The relevant values for the soil samples investigated are summarised in Table 5.

SOIL SAMPLE	D_{60}	D_{10}	D_{30}	C_u	C_z
Grange	0.7	0.001	0.012	700	0.206
Moorepark	0.3	0.002	0.032	150	1.707
Carlow	0.1	0.0001	0.006	1000	3.600
Dublin Till	1.2	0.001	0.025	1200	0.521

Table 5: Effective size, uniformity coefficient and curvature coefficient for soil samples

Soils whose uniformity coefficient is less than 2 are considered 'uniform', otherwise 'graded'. Examination of Table 5 shows that each of the four samples is reasonably well graded which is a typical characteristic of Irish glacial soils, with the Carlow material having the highest fines content. The Moorepark and Grange soils are somewhat gap-graded in the sand range (0.063 mm to 2.0 mm) with the Moorepark material having the greater coarse content.

No specific standard in Ireland exists for the assessment of soils suitable for use in animal waste storage tanks. However, reference can be made to a standard for landfill sites. Typical suitable ranges of parameters for use as landfill clay liners are shown below (EPA 2000, McCullen and Long 1999):

- maximum particle size: 25 – 50 mm;
- gravel content (> 2 mm): ≤ 30 %;
- fines content (< 63 μm): 20 – 30 %;
- clay content (< 2 μm): ≥ 10 %.

Three of the four soils tested are within these criteria, albeit with the Moorepark and Grange soils being borderline in one case and the Dublin Till being borderline in two cases. The Carlow soil has a high fines content but has sufficient clay to be suitable. All the soils pass the maximum particle size criterion because for a soil liner all particles greater than 50 mm are removed. The NRCS standards in the United States require that suitable soils should have at least 20 percent passing the US No. 200 (0.075 mm) sieve. In the USCS (United States Soil Classification), particles less than 0.075 mm are regarded as fines whereas the British Standards Institution

defines fines as all particles passing the 0.063 mm sieve. Based on the soil results, all four would therefore come within the NRCS criterion for minimum fines content. In the United Kingdom, CIRIA 126 recommends a minimum clay content of 10 percent for soil liners. Each of the four soil samples comes within this criterion. Clay, fines, sand and gravel contents for each of the four soil samples are presented in Table 2.

Particle size distribution curves, particularly of sands and gravels, have practical value. As far back as 1892, Hazen showed that soil permeability (K) is related in some fashion to some effective particle size:

Equation 3 Hazen soil permeability equation

$$K = 0.0116(D_{10})^2(0.7 + 0.03T)$$

where T = temperature of the water in degrees Celsius.

The Hazen equation can only be applied to grain size distributions with a uniformity coefficient < 5 but is often used to indicate likely soil permeability. If the equation is applied to the four soils tested and water temperature is assumed to be 25 degrees Celsius, then the following soil permeabilities are obtained:

SOIL SAMPLE	UNITS	HAZEN K
Grange	m/s	1.68 x 10 ⁻⁸
Moorepark	m/s	6.73 x 10 ⁻⁸
Carlow	m/s	1.68 x 10 ⁻¹⁰
Dublin Till	m/s	1.68 x 10 ⁻⁸

Table 6: Computed Hazen soil permeabilities for test soils

It may be concluded that the Hazen equation is in itself insufficient to calculate likely soil permeability. Although particle size distribution data is useful in soil classification, it should always be examined in conjunction with other classification tests.

The relationship of the moisture content to the liquid and plastic limits can be expressed numerically in two ways, using parameters known as the relative consistency, denoted by C_r (Terzaghi and Peck 1948) or the liquidity index, denoted by I_L (Lambe and Whitman 1969). These are determined as follows:

Equation 4 Relative consistency equation

$$C_r = \frac{\text{liquid limit} - \text{moisture content}}{\text{plasticity index}} = \frac{w_L - w}{I_p}$$

Equation 5 Liquidity index equation

$$I_L = \frac{\text{moisture content} - \text{plastic limit}}{\text{plasticity index}} = \frac{w - w_s}{I_p}$$

For the four soil samples tested, the following results were obtained:

SOIL SAMPLE	CR	I _L
Carlow	0.875	0.125
Moorepark	-0.091	1.091
Grange	1.200	-0.200
Dublin Till	1.333	-0.333

Table 7: Relative consistency and liquidity index of soil samples

Some typical values of relative consistency and liquidity index throughout the moisture content range are shown in Table 8.

MOISTURE CONTENT RANGE		CR	I_L
Below w_s	$w < w_s$	>1	Negative
At w_s	$w = w_s$	1	0
Between w_s and w_L	$w_s < w < w_L$	1 to 0	0 to 1
At w_L	$w = w_L$	0	1
Above w_L	$w > w_L$	Negative	>1

Table 8: Typical relative consistencies and liquidity indices

Atterberg limits specified by some regulatory authorities are presented in Table 9.

SOURCE	w_L %	I_p %
Irish EPA (Landfill liner)	≤ 90	10 to 30
United States (AWMFH)		16 to 40
United Kingdom (CIRIA)	≤ 90	≤ 65

Table 9: Some regulatory Atterberg limits for clay liners

In the United States agricultural waste management field handbook (AWMFH), the ideal soil has a plasticity index (I_p) around 30. Soils with an I_p between 16 and 40 are considered suitable for use as a clay liner. Examination of Tables 3 and 9 shows that, for each of the four soils investigated, the liquid limits are within the regulatory range, the Moorepark and Dublin Tills being borderline. However, although the plasticity index values fall within the design criteria recommended in the Republic of Ireland EPA landfill manual and the United Kingdom CIRIA report, they fall just outside the ideal range specified in the AWMFH.

As a convenient aid for comparing a variety of soils, Dr. A. Casagrande devised a plasticity chart (Figure 4), in which an empirical boundary known as the "A" line separates inorganic clays from silty and organic soils. Soils of the same geological origin usually plot on the plasticity chart as straight lines parallel to the A line. The larger the plasticity index the more deformable the soil will be. Plastic clays plot above the line. Organic soils, silts and clays containing a large portion of finely ground non-clay minerals plot below it. The relation of the natural water content to the liquid and plastic limits is indicative of soil behaviour. If the natural water content is above or close to the liquid limit, the soil may be "sensitive", in which case it may suffer a great loss of strength when disturbed. This sensitivity complicates sampling and testing and special procedures often have to be adopted. Results obtained from the Atterberg limit experiments were plotted on a plasticity chart which was taken from BS 5930 (1999), code of practice for site investigations.

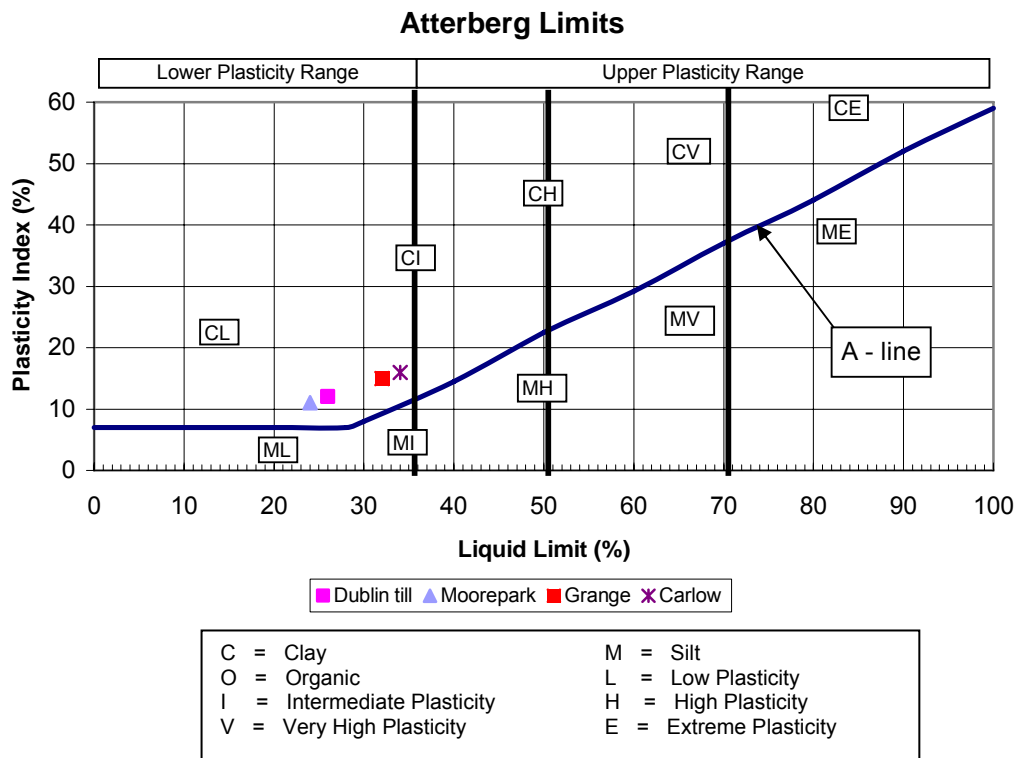

Figure 4: Atterberg limit results plotted on Plasticity Chart

The British Soil Classification System utilises the plasticity chart in the classification of soils. The soil is classified by observing the position of the point on the chart relative to the sloping straight line (A line) drawn across the diagram. Examination of Figure 4 shows that the Dublin Till and Moorepark soils are clays with low plasticity although both are quite close to the intermediate plasticity range. The Grange and Carlow soils can be classified as clays of intermediate plasticity, although in this case they would be very close to being of low plasticity.

Examination of the results for the permeability tests on the four soils show that when they are compacted using standard 'light' compaction methods, their coefficients of permeability are very low. If these values are compared to regulatory values for landfill soil liners and earth-banked tank soil liners it is clear that, with the exception of the Dublin Till, the soils would be suitable for use without requiring extensive re-working to further reduce the coefficient of permeability in each case (see Table 10).

REGULATION	SOURCE	K (M/S)	FURTHER REQUIREMENTS
BS 5502 Part 50	UK	$\leq 1 \times 10^{-9}$	
CIRIA Report 126	UK	$\leq 1 \times 10^{-9}$	
ADAS	UK	$\leq 1 \times 10^{-9}$	and ≥ 1 m thick
NRCS Code 313	US		specific discharge $\leq 1 \times 10^{-8}$ m/s
AWMFH	US	$\leq 1 \times 10^{-8}$	and 1 further order of magnitude for sealing
EPA Landfill Manual	IRE	$\leq 1 \times 10^{-9}$	
Inert Landfill	EU	$\leq 1 \times 10^{-7}$	and ≥ 1 m thick
Non-hazardous landfill	EU	$\leq 1 \times 10^{-9}$	and ≥ 1 m thick

Table 10: Some regulatory limits for coefficient of permeability

Examination of Table 10 shows that for UK landfill and earth-banked tank regulations, only the Carlow soil passed the coefficient of permeability criterion. In the United States, the AWMFH allows a clay liner to have an intrinsic coefficient of permeability of 1×10^{-8} m/s. Research in the US (AWMFH) has reported that under

the right conditions, the permeability of a soil can be decreased by up to several orders of magnitude in a few weeks following contact with waste in a storage tank. The regulatory guidelines contained in the AWMFH are developed under the premise that the permeability decrease induced by animal slurry should not be relied upon to protect groundwaters from contamination by animal wastes. However, the guidelines do propose allowing for the sealing of the soil by one order of magnitude for soils with a clay content of at least five percent. Therefore the Dublin Till would be acceptable under these circumstances.

The NRCS does not specify a minimum coefficient of permeability but rather a minimum specific discharge of 1×10^{-8} m/s. Specific discharge is defined as the seepage rate for a unit cross-sectional area of a tank and can be related to Darcy's law:

Equation 6 Darcy's law (using different notation from Equation 2)

$$Q = k \left(\frac{H+d}{d} \right) A \quad (\text{Darcy's Law})$$

where:

Q = total seepage through area A (m^3/s);

k = coefficient of permeability (hydraulic conductivity) ($m^3/m^2/s$);

(H+d)/d = hydraulic gradient;

H = vertical distance measured between the top of the liner and the required volume of the waste storage tank (m);

d = thickness of soil liner (m);

A = cross sectional area of flow (m^2);

L = length (m);

T = time (s).

Rearranging the terms of the equation gives:

$$\frac{Q}{A} = k \left(\frac{H+d}{d} \right)$$

Q/A is defined as specific discharge or v. Therefore;

Equation 7 Specific discharge equation

$$v = k \left(\frac{H+d}{d} \right)$$

Specific discharge, or unit seepage, is the quantity of water that flows through a unit cross-sectional area composed of pores and solids per unit of time. It has units of $m^3/m^2/s$ and is often simplified to m/s. Because specific discharge is expressed in units of m/s, it has the same units as velocity, and represents the average rate or velocity of water moving through a soil body rather than a quantity rate flowing through the soil. Since the water flows only through the soil pores, the cross sectional area of flow is computed by multiplying the soil cross section (A) by the porosity (n). The seepage velocity is then equal to the unit seepage or specific discharge, v, divided by the porosity of the soil, n. In compacted soil liners, the porosity usually ranges from 0.3 to 0.5 (AWMFH). Accordingly, the average linear velocity of the seepage flow is two or three times the specific discharge value. The units of seepage velocity are m/s. The specific discharge for the Dublin Till is calculated below assuming a liner thickness of 1m and a hydraulic gradient of 4:

$$v = 2.51 \times 10^{-8} \left(\frac{3+1}{1} \right) = 1.004 \times 10^{-7} \text{ m/s}$$

Because the NRCS regulations allow a reduction in permeability by sealing, the specific discharge is therefore equal to 1.004×10^{-8} m/s.

Conclusions

Four soils were selected from a number of locations and were considered typical of those found throughout Ireland (see Figure 1). These soils were subjected to basic soil tests, normally conducted to characterise a soil. The objective of the tests was to determine whether simple soil characterisation procedures could give a good assessment of soils suitability for use in the construction of earth-banked tanks. The soil characterisation tests chosen were natural moisture content, Atterberg limits, particle size distribution and permeability. These tests are typically used to assess soils for suitability as landfill clay liners. The findings essentially showed that each of the four soils satisfied most of the criteria for landfill clay liners and that basic soil tests such as particle size distribution give a good indication of the suitability of the soils for lining municipal leachate or agricultural slurry containment facilities. It was also found that particle size distribution analysis coupled with Atterberg limits were in most cases adequate to assess a soils suitability for use as a compacted liner.

EXPERIMENT 2: SOIL PLACEMENT AND MOISTURE CONTENT VARIATION TESTS

Introduction

Further investigation was carried out to determine whether the coefficient of permeability of the soils could be further reduced. Two methodologies were used, compactive effort variation and moisture content variation. Moisture content determination has been described in Experiment 1. A description of compactive effort is given below.

Compactive effort

A test to provide data on the compaction characteristics of soil was first introduced by R.R. Proctor in 1933, in order to determine a satisfactory state of compaction for soils being used in the construction of large dams, and to provide a means of controlling the degree of compaction during construction. The test made use of a hand rammer and a cylindrical mould with a known volume, and became known as the standard 'Proctor' compaction test.

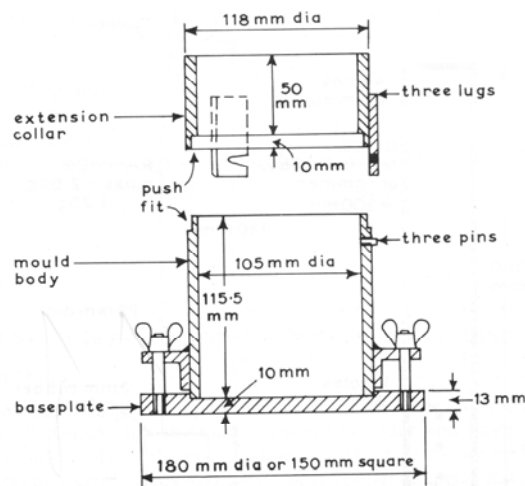

Figure 5: British Standard one-Litre compaction mould (Head 1997)

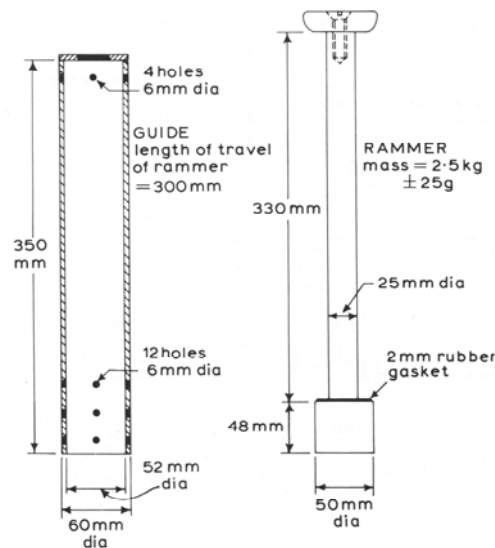

Figure 6: Rammer for British Standard 'light' compaction test (Head 1997)

The British Standard 'light' compaction test used in the preparation of triaxial permeability test samples is very similar. Compaction of soil is the process by which the solid soil particles are packed more closely together by mechanical means, thus increasing the dry density. It is achieved through the reduction of air voids in the soil, with little or no reduction in the water content. Therefore, an increase in compactive effort should result in a decrease in the permeability of the soil sample. Compaction of soil is achieved by means of mechanical energy applied to the soil in terms of the work done in operating the rammer. The amount of energy applied can be calculated as follows:

BS 'light' compaction test

- Mould volume: 0.001 m³;
- Mass of rammer: 2.5 kg;
- Drop: 0.3 m;
- No. of layers: 3;
- Blows per layer: 27.

$$\text{Mechanical energy applied} = (2.5 \text{ kg}) \times 0.3 \text{ m} \times 27 \times 3 = 60.75 \text{ kgm} \\ = 60.75 \times 9.81 \text{ Nm} = 596 \text{ J}$$

Volume of soil used = 0.001 m³, therefore

$$\text{Work done per unit volume of soil} = \frac{596}{0.001} \text{ J/m}^3 = 596 \text{ kJ/m}^3$$

Compactive effort variation

The compactive effort was altered by varying the number of layers used in soil compaction from two to five, each layer receiving twenty seven blows of the rammer (see Table 11).

	LIGHTEST	STANDARD 'LIGHT'	HEAVIER	HEAVIEST
No. of layers	2	3	4	5
Work done on sample (J)	397	596	795	993
Work done per unit volume of soil (kJ/m ³)	397	596	795	993

Table 11: Compactive effort applied to each soil sample

Three of the four soils investigated (Dublin Till, Moorepark and Grange) were prepared for a triaxial permeability test as described earlier. During sample preparation, compaction was systematically varied as per Table 11. A standard 'light' compaction sample was not required as this experiment had already been carried out.

Moisture content variation

For each of the four soils tested, the natural moisture content was first determined and then by either air drying or by the addition of distilled water, the moisture content of the soil samples was varied. Each soil sample was compacted using standard 'light' compaction methods as described earlier and subjected to triaxial permeability tests.

Results and discussion

Results obtained from the compactive effort variation series of experiments are presented in Tables 12, 13 and 14 below.

MOOREPARK SOIL					
Data	units	2 layers	3 layers	4 layers	5 layers
Coefficient of permeability	k (m/s)	4.55×10^{-9}	2.21×10^{-9}	4.45×10^{-9}	7.08×10^{-9}
Moisture content	%	24.95	24.95	25.44	25.44
Void ratio	e	0.83	0.72	0.65	0.51
Bulk density	(Mg/m ³)	1.84	1.96	2.06	2.25
Dry density	(Mg/m ³)	1.48	1.57	1.64	1.79

Table 12: Results for Moorepark compaction variation permeability tests

DUBLIN TILL					
Data	units	2 layers	3 layers	4 layers	5 layers
Coefficient of permeability	k (m/s)	4.72×10^{-8}	2.51×10^{-8}	8.24×10^{-10}	2.12×10^{-10}
Moisture content	%	9.17	8.85	9.21	9.17
Void ratio	e	0.36	0.32	0.25	0.24
Bulk density	(Mg/m ³)	2.16	2.22	2.35	2.37
Dry density	(Mg/m ³)	1.98	2.04	2.15	2.17

Table 13: Results for Dublin till compaction variation permeability tests

GRANGE					
Data	units	2 layers	3 layers	4 layers	5 layers
Coefficient of permeability	k (m/s)	6.24×10^{-10}	2.74×10^{-9}	2.25×10^{-10}	1.01×10^{-9}
Moisture content	%	14.5	14.5	14	14
Void ratio	e	0.41	0.38	0.37	0.36
Bulk density	(Mg/m ³)	2.20	2.23	2.24	2.27
Dry density	(Mg/m ³)	1.92	1.95	1.96	1.99

Table 14: Results for Grange compaction variation permeability tests

Increase in compactive effort should have resulted in an increase in the bulk density of a soil. This is graphed in Figure 7. Examination of Figure 7 shows that there was a distinct correlation between compactive effort and the resultant bulk density. The coefficient of permeability achieved for each sample at a particular compactive effort is plotted against the corresponding bulk density achieved for that sample. The results are graphed in Figure 8.

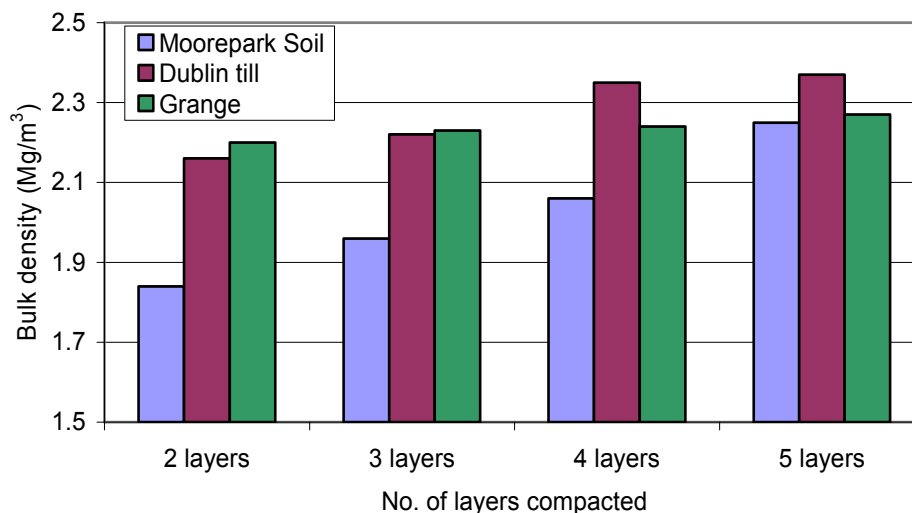

Figure 7: Variation in bulk density for each soil subjected to varying compactive efforts

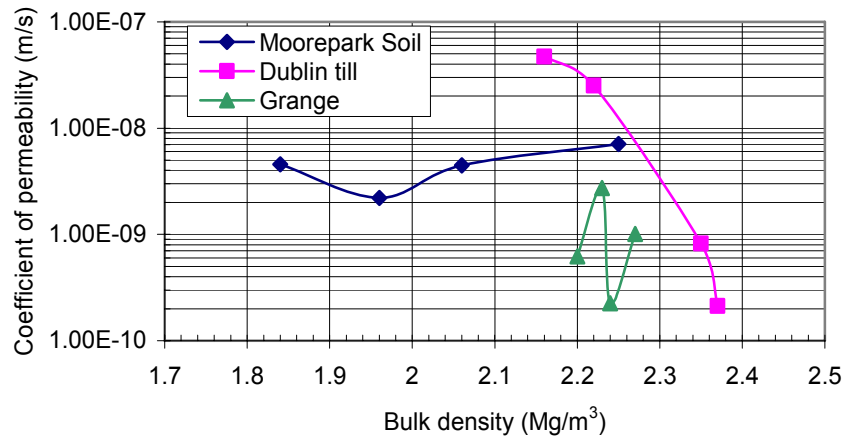

Figure 8: Variation of coefficient of permeability with bulk density under varying compaction levels

Examination of Figure 8 shows that the relatively coarse Grange material is insensitive to bulk density but has a permeability value quite close to the target value. All tests on the coarse Moorepark soil fail the criterion. Only the Dublin Till material appears to have a permeability which is sensitive to bulk density (possibly due to the grading of the material). Beyond a bulk density of 2.3 Mg/m³ the material has an acceptable permeability value. However, in order to achieve density values such as this in the field, very heavy compaction plant would be required.

A further series of laboratory tests were undertaken to examine the sensitivity of the soils' permeability to the moisture content of the soil when compacted. For each of the four soils tested, the natural moisture content was first determined and then by either air drying or by the addition of distilled water, the moisture content of the soil samples was varied. Each soil sample was compacted using standard 'light' compaction methods as described earlier and subjected to triaxial permeability tests. The results are tabulated below:

MOOREPARK SOIL				
Data	units	Drier sample	Drier sample	Natural moisture content
Coefficient of permeability	k (m/s)	1.41 x 10 ⁻⁸	2.92 x 10 ⁻⁸	2.21 x 10 ⁻⁹
Moisture content	%	16.72	19.48	24.95
Void ratio	e	0.68	0.75	0.72
Bulk density	(Mg/m ³)	1.88	1.85	1.96

Table 15: Results for Moorepark moisture content variation permeability tests

DUBLIN TILL				
Data	units	Drier sample	Natural moisture content	Wetter sample
Coefficient of permeability	k (m/s)	2.95 x 10 ⁻⁹	2.51 x 10 ⁻⁸	1.12 x 10 ⁻⁹
Moisture content	%	5.80	8.85	9.40
Void ratio	e	0.86	0.32	0.49
Bulk density	(Mg/m ³)	1.51	2.22	1.98

Table 16: Results for Dublin till moisture content variation permeability tests

GRANGE				
Data	units	Driest sample	Drier sample	Natural moisture content
Coefficient of permeability	k (m/s)	1.10×10^{-8}	5.40×10^{-8}	2.74×10^{-9}
Moisture content	%	10.24	11.97	14.49
Void ratio	e	0.50	0.38	0.38
Bulk density	(Mg/m ³)	1.99	2.19	2.23

Table 17: Results for Grange moisture content variation permeability tests

CARLOW SOIL				
Data	units	Drier sample	Natural moisture content	Wetter sample
Coefficient of permeability	k (m/s)	1.51×10^{-10}	1.12×10^{-10}	2.09×10^{-10}
Moisture content	%	22.0	23.21	24.0
Void ratio	e	0.52	0.46	0.46
Bulk density	(Mg/m ³)	2.17	2.28	2.29

Table 18: Results for Carlow moisture content variation permeability tests

A plot of moisture content against coefficient of permeability is shown in Figure 9.

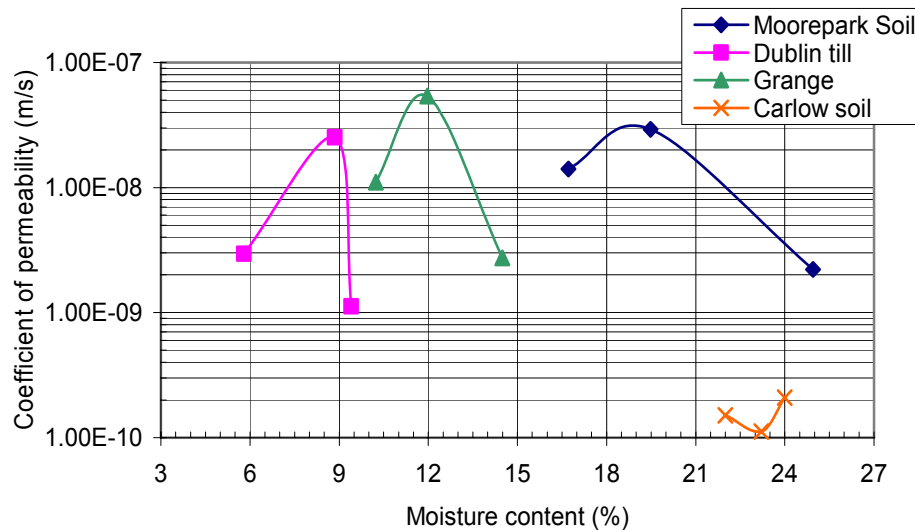

Figure 9: Variation of coefficient of permeability with moisture content

Figure 9 clearly shows that changes in soil moisture content influence the permeability of the soil sample but not in a manner which would indicate a high level of sensitivity. Because there are relatively few data points available, it is difficult to make any definitive conclusions regarding the relationship between moisture content and permeability. For the range of data available, again, only the Carlow material passes the acceptability criterion of 1×10^{-9} m/s in all cases. The values obtained for the other material show little sensitivity of permeability to moisture content and generally fail the criterion. The Moorepark soil does seem to be tending towards acceptability but the soil would appear to require either additional compaction to further increase the bulk density or further moisture addition to reduce the permeability.

Benson et al. (1994) conducted a study to establish the relationship between hydraulic conductivity and associated soil properties that were extracted from construction reports for compacted soil liners used in landfill sites. Sixty seven site reports were used in total. The database was used to evaluate relationships between hydraulic conductivity, compositional factors and compaction variables and to identify minimum values for soil properties that are likely to yield a hydraulic conductivity $\leq 1 \times 10^{-9}$ m/s.

The trends evident in graphs produced by Benson et al. indicate that hydraulic conductivity is more sensitive to percentage of fines and percentage of clay than to percentage of sand and or percentage of gravel. The boundaries in the graphs can be used to estimate minimum percentages of fines and clays that are needed to achieve a hydraulic conductivity of 1×10^{-9} m/s. The lower bounds suggest a minimum percentage of fines of ≥ 30 % and a minimum percentage of clay of ≤ 15 %. Examination of Table 2 shows that only the Dublin Till has a fines content significantly lower than the minimum suggested, whereas although the Moorepark and Dublin Till soils do not meet the clay requirement, they are very close to the minimum.

Benson et al. established the correlation between hydraulic conductivity and Atterberg limits. Their graphs show lower and upper bounds that encompass the majority of the selected data. Examination of the graphical relationship in Benson et al. shows that the hydraulic conductivity of a soil can be estimated from Atterberg limit values if the lower bound is used. Therefore, a geometric mean hydraulic conductivity of 1×10^{-9} m/s can be achieved if the liquid limit is ≥ 20 and the plasticity index ≥ 7 . Using these minimum requirements, we see that all four soils easily fall within the recommended range. Benson also examined the activity of the soils in his database and correlated the results to the hydraulic conductivity. Activity is defined as the plasticity index divided by the clay fraction of the soil (Skempton 1953). Because clay minerals with greater activity are likely to consist of smaller particles having larger specific surface and thicker double layers, hydraulic conductivity would be expected to decrease with increasing activity. This trend is confirmed in the graph. The graph further indicates that a minimum activity of 0.3 would be required to achieve the desired hydraulic conductivity. Examination of the four soils tested shows that their activities ranged from 0.73 for the Carlow soil to 0.88 for the Grange soil. These are all well above the minimum activity specified for achieving a hydraulic conductivity of 1×10^{-9} m/s.

By combining all of the minimum requirements from the graphs, Benson compiled a table of recommended minimum criteria which would reasonably be expected to result in a soil with a hydraulic conductivity of 1×10^{-9} m/s or less. By comparing these minimum criteria with the results obtained from tests undertaken on the four soils investigated, an evaluation can be made of the soils' expected hydraulic conductivity (see Table 19 below).

PROPERTY	MINIMUM FOR 1×10^{-9} m/s HYDRAULIC CONDUCTIVITY	GRANGE	MOOREPARK	CARLOW	DUBLIN TILL
Liquid limit	20	32	24	34	26
Plasticity index	7	15	11	16	12
% fines	30	29	34	56	24
% clay	15	17	13	22	14
Activity	0.3	0.88	0.85	0.73	0.86

Table 19: Soil properties to achieve hydraulic conductivity of 1×10^{-9} m/s compared with results for four soils investigated (adapted from Benson et al. 1994)

Examination of Table 19 shows that one could expect that the Carlow soil would have the lowest hydraulic conductivity as it is well above all five criteria. The Dublin Till is below the minimum requirement for both percentage fines and percentage clay and could reasonably be expected to have a hydraulic conductivity close to 1×10^{-9} m/s. Examination of the permeability tests carried out show that the Dublin Till has a hydraulic conductivity of 2.51×10^{-8} m/s and the Carlow soil 1.12×10^{-10} m/s. These results show that all five criteria must be used together to approximate hydraulic conductivity and that when this methodology is used, very good results are obtained. It is, however, important that a soil not be discounted for use in the construction of an earth-banked tank solely on the basis of the criteria listed above. In this experiment, it was shown how the hydraulic conductivity of the soil could be reduced by varying the method of placement of the soil either by changing the moisture content or the compactive effort during construction.

These findings are borne out in the literature. O'Sullivan et al. (2002) examined details on the background and application of clay liners in Irish landfill situations. The authors state that the permeability of a remoulded clay is influenced by a number of factors, the key ones being plasticity, density, moisture content during compaction and method of compaction. This statement concurs with the findings by Benson et al. (1994). O'Sullivan also found that simple laboratory tests such as Atterberg limits, moisture content and grading tests gave a good initial appraisal of the potential suitability of a soil for the construction of a impermeable liner as an approximate permeability could be determined from these parameters. The authors concluded that engineering a soil to produce a compacted clay liner with a minimum hydraulic conductivity of 1×10^{-9} m/s was not as difficult as might be envisaged and that permeability behaviour was dependent on the key factors, namely moisture content, plasticity and grading.

Conclusions

- Each of the four soils selected for testing satisfied most of the criteria for landfill clay liners.
- By manipulation of the moisture content or compactive effort applied to each soil, the hydraulic conductivity of the soils could be further reduced.
- Simple laboratory tests such as Atterberg limits, moisture content and grading tests give a good assessment of the potential suitability of a soil for the construction of a impermeable liner.
- Of the four soils tested, earth-banked tanks could possibly have been constructed in three of the soils without requiring a re-worked soil liner, as the in-situ soil conditions met the seven criteria. The other soil was borderline and would require re-working, namely, by increasing the compactive effort.

EXPERIMENT 3: SOIL/SLURRY TESTS

Introduction

Researchers (Culley et al., 1982) have established, in full-scale field trials, that animal slurries in contact with soil do cause a progressive sealing of the soil with time, thereby significantly reducing the effective permeability of the soil. The laboratory measurement of the permeability of porous media at very low values presents significant difficulties for conventional laboratory geotechnical equipment, such as the permeameter or manually operated triaxial apparatus, and requires the use of sophisticated computer-controlled apparatus such as that used in the soil-water experiments described above. However, animal slurries are unsuitable for use in such sophisticated apparatus due to problems with clogging of lines and potential damage to sensors.

To overcome these difficulties, the specific resistance to filtration (SRF) apparatus (Coackley and Jones, 1956) used in the laboratory assessment of the dewaterability of water and wastewater treatment sludges was adapted to study the flow of animal slurry through porous media (flow through a sludge cake and the filter medium is analogous to flow through a porous medium).

Modified SRF test

In the SRF test (see Figure 10(a)), an aliquot of the sludge is placed onto a filter paper (Whatman no. 1,) in a Buchner funnel (70 mm diameter) and drawn through by vacuum pump; the cumulative filtrate volume is recorded as a function of time. In adapting the SRF test to the case of animal slurry flowing through soil, it was considered to be inappropriate to draw the slurry through the soil by suction, because of the potential problem of air binding within the porous medium at sub-atmospheric pressures. Instead, the SRF test apparatus was modified to enable a positive pressure to be applied to the upper surface of soil specimen, while maintaining the lower surface at approximate atmospheric pressure (Figure 10 (b)).

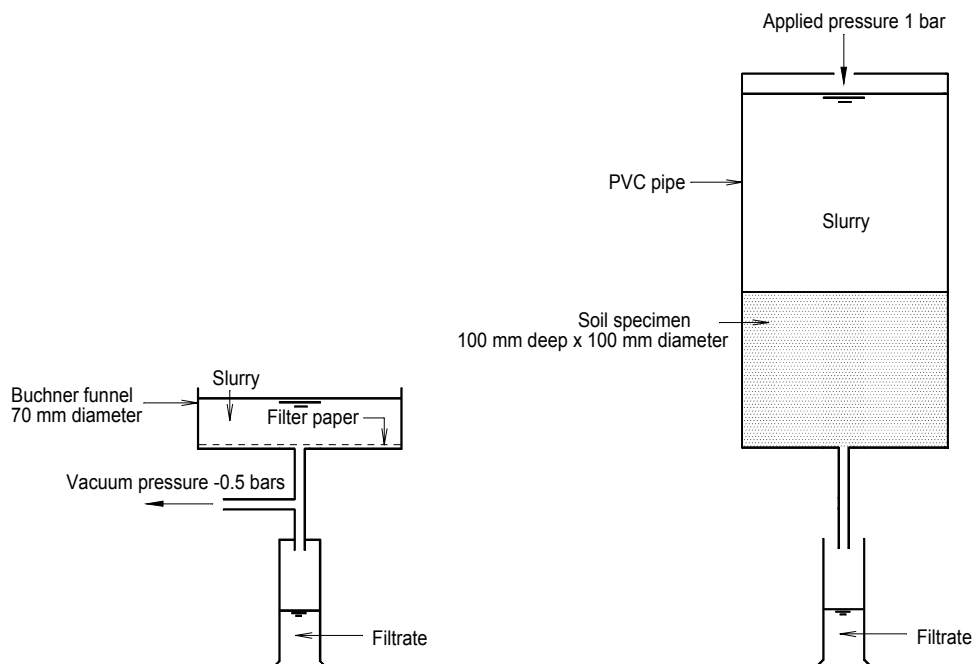

Figure 10: (a) SRF apparatus and (b) Modified SRF apparatus



Figure 11: Modified SRF apparatus

The soil chosen for this series of laboratory experiments was Leighton Buzzard sand since it is reasonably uniformly graded sand of silica origin with approximately 95 percent of the grains between 0.3 and 0.5 mm in diameter. A variety of fluids were used: animal slurry, waterworks sludge and treated leachate from a landfill site.

Initially, the flow characteristics of cattle slurry through a standard laboratory filter paper was investigated using the conventional specific resistance to filtration (SRF) apparatus. Cattle slurry with a total solids content of 6.8 % was diluted to a total solids content of 1.5 % using distilled water and the latter was used as the test fluid. The results are graphed in Figure 12 below.

Slurry with the same total solids concentration of 1.5 % was then applied to a Leighton Buzzard soil sample in the modified SRF test apparatus. The soil sample was 100 mm in diameter and 100 mm in height. An applied pressure of 1 bar (~10.3m head of water) was selected for use to allow the test to proceed at a reasonably rapid rate. The soil was first saturated using distilled water for a period of 30 minutes. The water was allowed to drain from the sample and the valve beneath the apparatus closed. Slurry was applied to the soil column and the apparatus was sealed at the top. A pressure of 1 bar was then applied to the slurry and the allowed to equilibrate for a period of ten minutes. The valve at the base of the apparatus was then opened and the volume of filtrate collected measured at varying time intervals. This process continued until no further increase in total filtrate volume collected was discernable. Results for this procedure are graphed in Figure 13 in the same manner as in Figure 12.

Tests were repeated using cattle slurry of varying solids contents to examine the effect of solids content on seepage rates and further experiments were carried out using landfill leachate and sludge taken from a water treatment works. In the tests carried out on the waterworks sludge, both the total solids and pressure head were varied to examine how each parameter affected the percolation rate through the soil sample. Aluminium hydroxide sludge from a water treatment works was applied to the Leighton Buzzard sand. The sludge, with a 3.5 % total solids content, was diluted using distilled water to total solids contents of 3, 2.5 and 2 % respectively. The diluted samples were then applied to Leighton Buzzard sand under varying pressure heads of between 0.25 ~ 0.75 bar in the same manner as described above.

Results and discussion

SRF result in the case of cattle slurry with a solids concentration of 1.5% is presented in Figure 12.

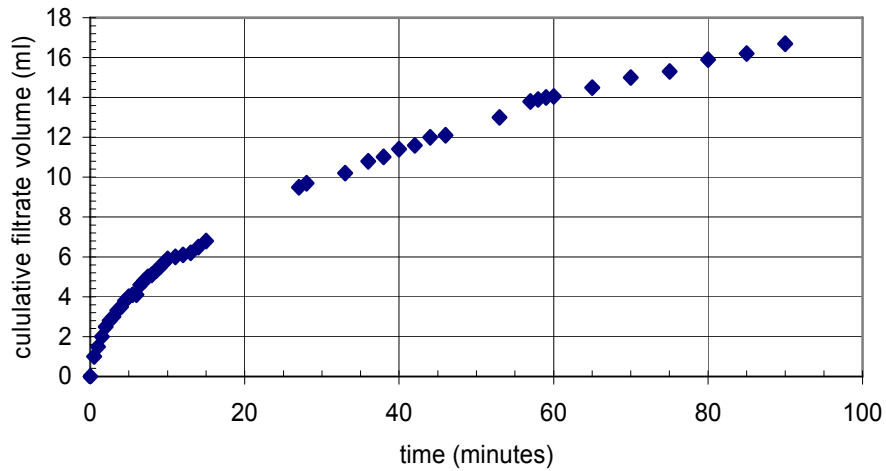

Figure 12: Slurry flow through laboratory filter paper

The graph shows how the cumulative filtrate volume collected in the graduated cylinder beneath the filter paper reduced markedly as time from start of test increased. At the commencement of the test, the slurry percolated through the filter paper relatively quickly under a vacuum pressure. However, as time progressed, the solids in the slurry solution were trapped on the surface of the filter paper as the slurry was drawn through the paper under a vacuum pressure. The deposition of solids increased over time which resulted in a reduced rate of liquid flow through the cake mass and the filter paper, and a corresponding reduction in the volume of filtrate collected (see Figure 12).

A typical result for the flow of the same cattle slurry through 100 mm deep by 100 mm diameter specimen of Leighton-Buzzard sand in the modified SRF apparatus is presented in Figure 13.

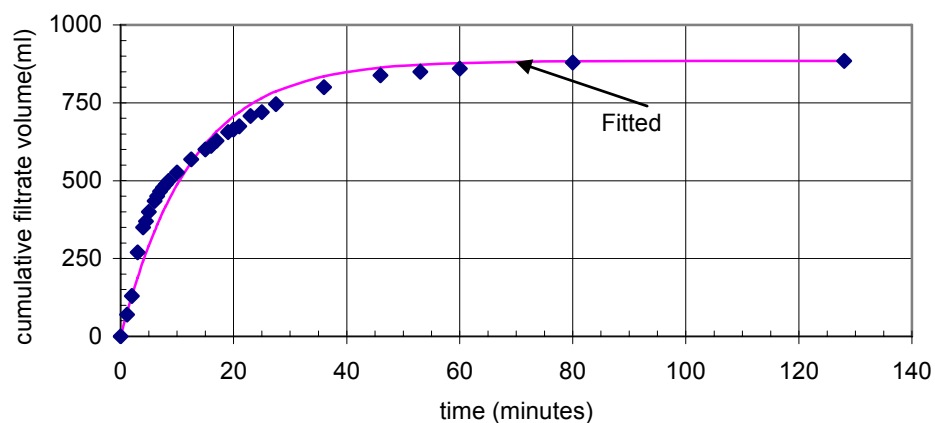

Figure 13: Slurry flow through Leighton-Buzzard sand using modified SRF apparatus

Examination of Figures 12 and 13 shows that, although there is only a difference of a factor of two in plan areas of the respective test specimens, there is a considerably larger volume of filtrate in the case of the slurry flow through the sand

specimen. Clearly, the filter paper and the slurry cake formed on the surface of the filter offers much greater resistance to the flow than does the much more porous sand. In the case of the filter paper, all the suspended solids in the slurry were retained on the surface of the filter, whereas in the case of the sand, some penetration of the slurry solids into the pores of the sand occurred and resistance to flow was a combination of both the surface cake and sand bed. The sand specimen was housed in a clear walled PVC pipe and visual inspection corroborated this observation (i.e. deposition of solids on sand surface and within the sand bed). Examination of Figure 13 would appear to suggest an exponential flow decay through the sand bed, and a best-fit curve of this form is indicated on the figure, which is described by the following equation:

Equation 8 Flow decay equation for slurry through Leighton Buzzard sand

$$V = 885(1 - e^{-0.08t})$$

where:

V = cumulative filtrate volume (ml)

t = time from start of filter run (minutes).

The volumetric flow rate at any time $t(\frac{dV}{dt})$ is therefore: $70.8e^{-0.08t}$ (ml/minute)

The corresponding computed effective permeability (k) of the sand specimen at any time t is presented in Figure 14.

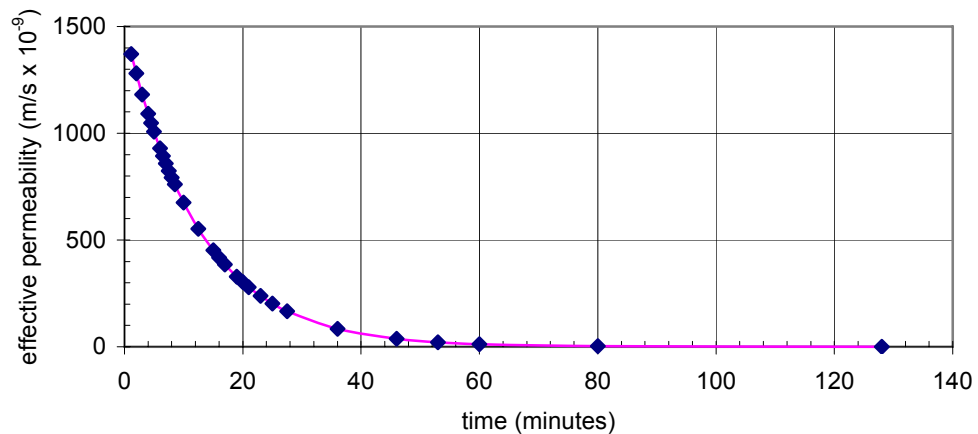

Figure 14: Effective permeability of Leighton Buzzard sand due to progressive sealing by slurry

In a landfill site the target coefficient of permeability for a compacted soil liner is 1×10^{-9} m/s. Replotting Figure 14 shows the rate at which the Leighton Buzzard sand reaches this target value under the application of cattle slurry with low solids content (1.5 %) at a pressure of 1 bar.

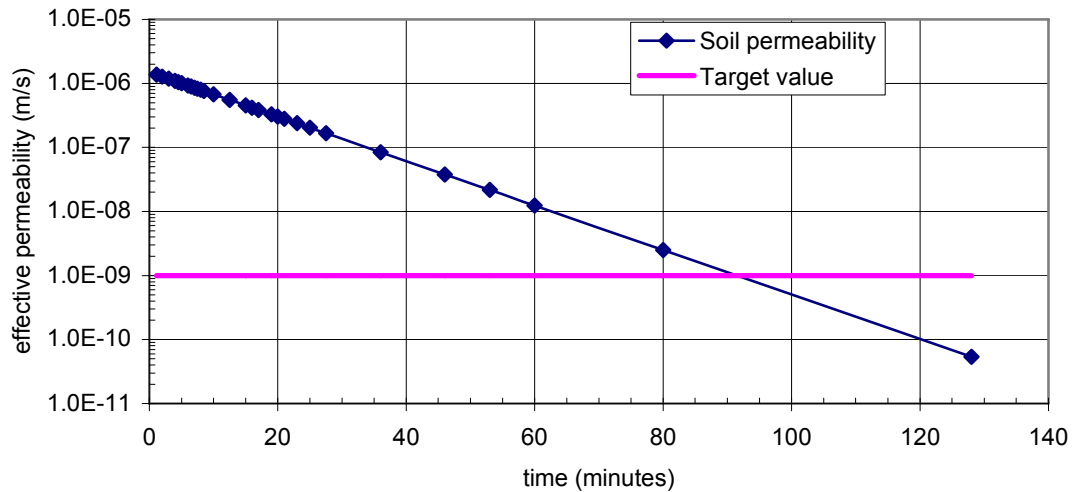

Figure 15: Effective permeability of Leighton-Buzzard sand due to progressive sealing by cattle slurry (logarithmic scale)

Examination of Figure 15 shows that, within 90 minutes after applying the slurry, the effective permeability of Leighton Buzzard sand reduced from 2×10^{-6} m/s to 1×10^{-9} m/s.

Tests were repeated using cattle slurry of varying solids contents to examine the effect of solids content on seepage rates. The original sample, with a total solids of 6.8 %, was diluted using distilled water to total solids contents of 2, 3, 4 and 5 % respectively. A constant pressure head of 0.5 bar (~ 5 m water pressure) was applied to each sample (98 mm in diameter and 50 mm high) which was comprised of Leighton Buzzard sand. The experimental procedure was the same as described above, with the soil sample first being saturated for 30 minutes prior to commencement of permeability measurement. Results are presented in Figure 16.

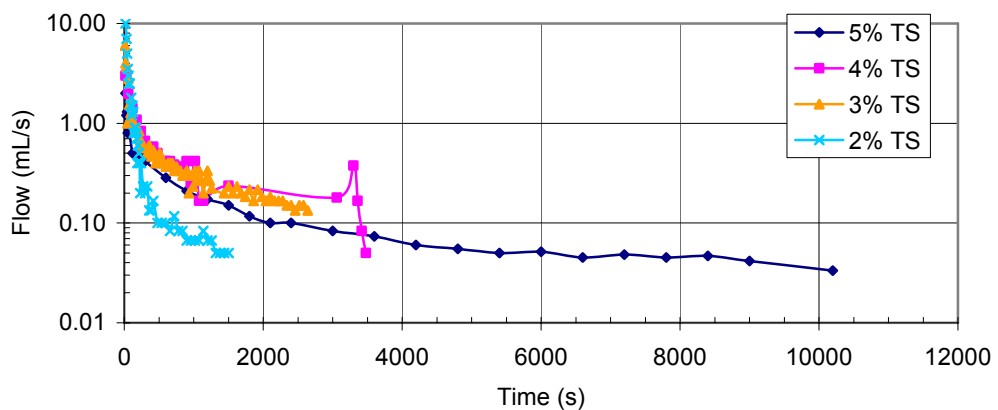

Figure 16: Reduction in flow rate through Leighton-Buzzard sand under the application of cattle slurry of varying total solids contents and constant pressure of 0.5 bar

Examination of Figure 16 shows that soil sealing occurs in all four cases. There are, however, some inconsistencies in the results obtained. It could reasonably be expected that the slurry with the highest solids content should display the greatest sealing effect. Further experiments were carried out using landfill leachate and

sludge taken from a water treatment works. In the tests carried out on the waterworks sludge, both the total solids and pressure head were varied to examine how each parameter affected the percolation rate through the soil sample. Some of the results obtained are presented in Figure 17.

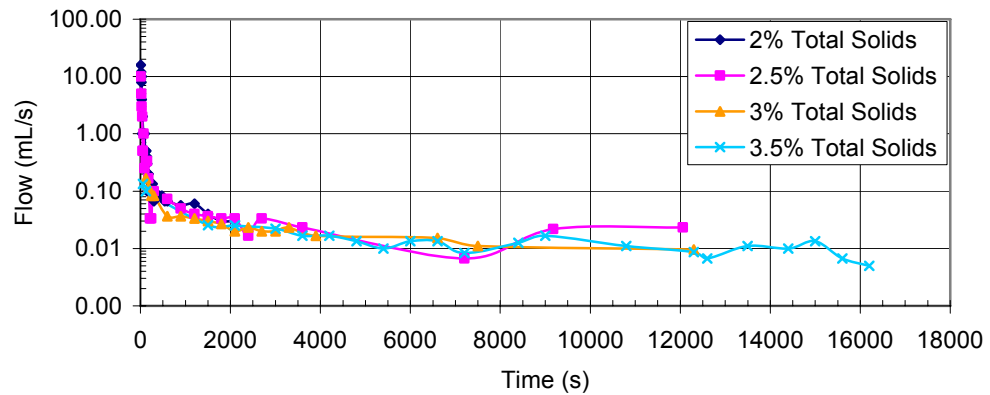

Figure 17: Flow rate through Leighton-Buzzard sand for waterworks sludge of varying total solids contents under a constant pressure of 0.25 bar

Examination of the results presented in Figure 17 shows that a suspension such as aluminium hydroxide sludge does cause sealing of the soil over time.

Discussion

It can be concluded from the experiment that cattle slurry of low solids content can significantly reduce the effective permeability of soil under high pressures (~10.3 m head of water). In full-scale application in the field, the cattle slurry stored in an earth-banked tank will typically have a solids content greater than 1.5 %, the applied head would be significantly less (~ 3 – 4 m) and the soil stratum an order of magnitude greater (~ 1 m). It is reasonable to conclude, therefore, that the seepage through the soil liner of an earth-banked tank will be less than that reported in this laboratory study.

A completely impermeable soil liner is not realistic because all soils do have a finite permeability and therefore some seepage, however infinitesimal, will always occur. Re-working the soil can reduce its hydraulic conductivity but other methods may be employed if the desired hydraulic conductivity cannot be attained by engineering methods alone. One method of reducing the hydraulic conductivity is by passing a suspension through the soil. The deposition of the suspended solids will reduce the effective permeability of the soil. Permissible seepage rates are normally specified on the basis of the flow of clean water through the containing soil liner and are therefore conservative since the sealing effect due to the contained solids in the liquid flowing is generally ignored. The primary (short term) sealing mechanism of such solids is generally considered to be physical blocking of the soil pores, while a secondary (long term) mechanism is due to the development of a biofilm on the surface of the soil liner. Results obtained from laboratory studies using the specific resistance to filtration (SRF) apparatus and the modified SRF apparatus clearly show that the hydraulic conductivity of a soil decreases rapidly due to the sealing effect of the animal waste on the soil.

In the United States, the Agricultural Waste Management Field Handbook (AWMFH) contains liner design guidelines which were developed with the proviso that the permeability decrease induced by the animal waste should not be counted on as the sole means of ground water protection, but that when designing a clay liner, a

sealing effect of one order of magnitude could be used to account for animal waste deposition on the soil. The sealing effect is ascribed in the AWMFH to a combination of physical, chemical and biological processes whereby suspended solids settle or filter out of solution and physically clog the pores of the soil mass. Anaerobic bacteria produce by-products that accumulate at the soil-water interface and reinforce the seal.

Conclusions

- Under relatively high pressures (~ 10.3 m head), animal slurry of low total solids content (1.5 %) had the ability to almost completely seal a column of sand after a relatively short period of time (~ 90 minutes).
- Infiltration rate was influenced by the applied pressure and total solids content of the slurry.
- When the experiments were repeated using an inert waterworks sludge as the test fluid similar results were obtained. It was concluded, therefore, that sealing appeared to be purely physical through deposition of solids on and within the upper layers of the sand column.
- Animal slurries do form a seal on soil, and that if this effect is accounted for in the design of earth-banked tanks, then the risk of excessive seepage is minimal
- The fragility of such a seal would have to be assessed in terms of wetting/drying and regular emptying, filling and agitation of the slurry contained in the earth-banked tank.

EXPERIMENT 4: FULL-SCALE FIELD TESTS

Introduction

A detailed experimental programme was undertaken at Teagasc Grange Research Centre commencing in June 2000. A comprehensive site investigation was conducted at a proposed site for a full-scale earth-banked tank comprising a desk study, visual assessment, trial hole investigation, subsoil sample collection and laboratory analysis. Based on the findings of the site investigation, it was concluded that an earth-banked tank could be constructed at the site. Concurrent to the earth-banked tank construction, boreholes were installed to monitor the groundwater surrounding the tank. Indirect infiltration measurements were taken using a water balance methodology.

Full-scale earth-banked tank

A full-scale earth-banked tank was constructed in November 2000 at the Teagasc Grange Beef Research Farm, Dunsany, Co. Meath and is the subject of the field study described in this chapter. The tank was constructed using a standard cut and fill technique, the banks of the tank extending approximately 1.5 m above the original ground level and the invert of the tank about the same distance below the original ground level. The internal sides of the tank were formed at a gradient of 1 (vertical) : 2 (horizontal) and the top width of the embankment was approximately 3 m.



Figure 18: Grange earth-banked tank after emptying (2001)

Prior to construction, the site was selected by collecting subsoil samples from trial holes excavated within the proposed footprint and analysing in the laboratory for particle size distribution, Atterberg limits and hydraulic conductivity. Details of the tests conducted and relevant soil properties have already been presented in Experiment 2. The soil used in the construction of the earth-banked tank was classified as a glacial till. This upper stratum of soil is underlain by more than 2 m of a shallow confined aquifer of outwash gravels and sands which sits for the most part on a thinly fractured (< 1m thick) layer of shaley Namurian limestone bedrock. Otherwise, the bedrock is covered by a dark coloured till of calp limestone origin.

The tank was constructed by first stripping the topsoil from the footprint of the tank. The topsoil was stored for later re-use on the outward faces of the earth-banked tank. Suitable excavated subsoil was then used to form the embankments of the tank. The inner banks and base of the tank were excavated to a depth approximately 300 mm below the finished profile of the tank, the additional excavated material then replaced on the inner banks and base and compacted with mechanical compaction plant. To ensure that the tank was made as water-tight as possible, it was essential that the sides and floor of the tank were constructed of

tough plastic soil and that all permeable material (sand, gravel etc.) was removed and replaced with impermeable material. To ensure that the inner faces of the tank were well-compacted, installation of the liner was supervised by the author to ensure that (a) the correct subsoil as identified during the site investigation was used for the liner, (b) the subsoil was installed in lifts no greater than 150 mm thick, and (c) each lift was compacted as per the design requirements to achieve adequate impermeability. Figure 19 shows a well-compacted subsoil liner approximately 5 days after construction.



Figure 19: Compacted subsoil liner

The embankment was formed by compacting suitable fill material in layers of approximately 150 mm. A cut-off trench was installed at the lower end of the earth-banked tank to ensure that a seasonally high water table would not come to within the invert of the tank.

Tank measurements

Groundwater levels and groundwater quality were monitored by constructing boreholes around the periphery of the tank. Twenty three boreholes were installed around the tank. A plan view of the earth-banked tank and the locations of the boreholes is presented in Figure 20 and is taken from a survey of the earth-banked tank site.

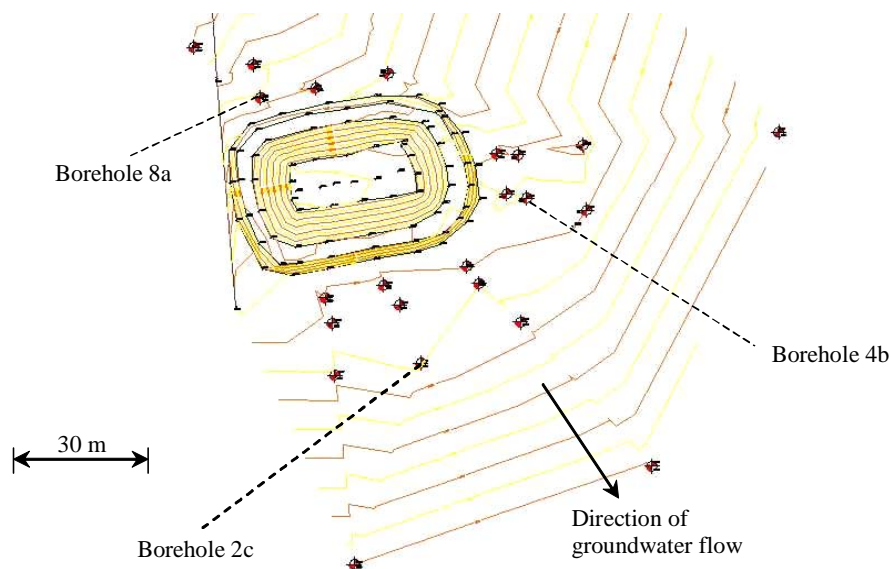

Figure 20: Plan view of tank and borehole locations

Following the construction of the earth-banked tank and the boreholes shown in Figure 20, background groundwater quality and level measurements were taken to establish a baseline dataset before the tank was filled with cattle slurry. The normal range of water quality parameters (BOD_5 , nitrate, phosphate, ammonia, conductivity etc.) were routinely monitored. Cattle slurry was pumped into the tank over the three day period 14 February 2002 to 16 February 2002, filling the tank to a depth of

approximately 3 m. Groundwater quality, groundwater level and slurry infiltration rate were monitored post-filling of the tank. The slurry infiltration rate was estimated using a water balance method, changes in the tank surface levels being monitored and the estimated evaporation rates deducted. Boreholes were installed at an on-farm meteorological site to act as water quality control. Evaporation and precipitation measurements recorded at this meteorological station were used in slurry infiltration rate determinations. The meteorological station is shown in Figure 21.



Figure 21: Grange research station meteorological site (inset shows control boreholes)

The rate of slurry infiltration into the soil was estimated by monitoring changes in slurry level in the earth-banked tank, using a hook gauge graduated to 0.01 mm. Evaporation rates from the tank were measured using a standard class A pan. Because pan evaporation rates have been found to be higher than evaporation rates from larger bodies of water (Shaw 1996, WMO 1966), it was necessary to apply a correction factor (0.7) to the measured values. Monthly evaporation, tank level change and rainfall data, following the filling of the tank with slurry were monitored. There are no specific international standards in respect of permissible slurry infiltration rates from earth-banked tanks to the adjacent groundwater. For example, a number of states in the U.S. specify maximum seepage rates ranging from 0.42 mm/day to 6.3 mm/day (Parker et al. 1999).

Results

Groundwater quality

Some relevant groundwater quality data from three boreholes around the earth-banked tank and the control meteorological site is presented in Figure 22.

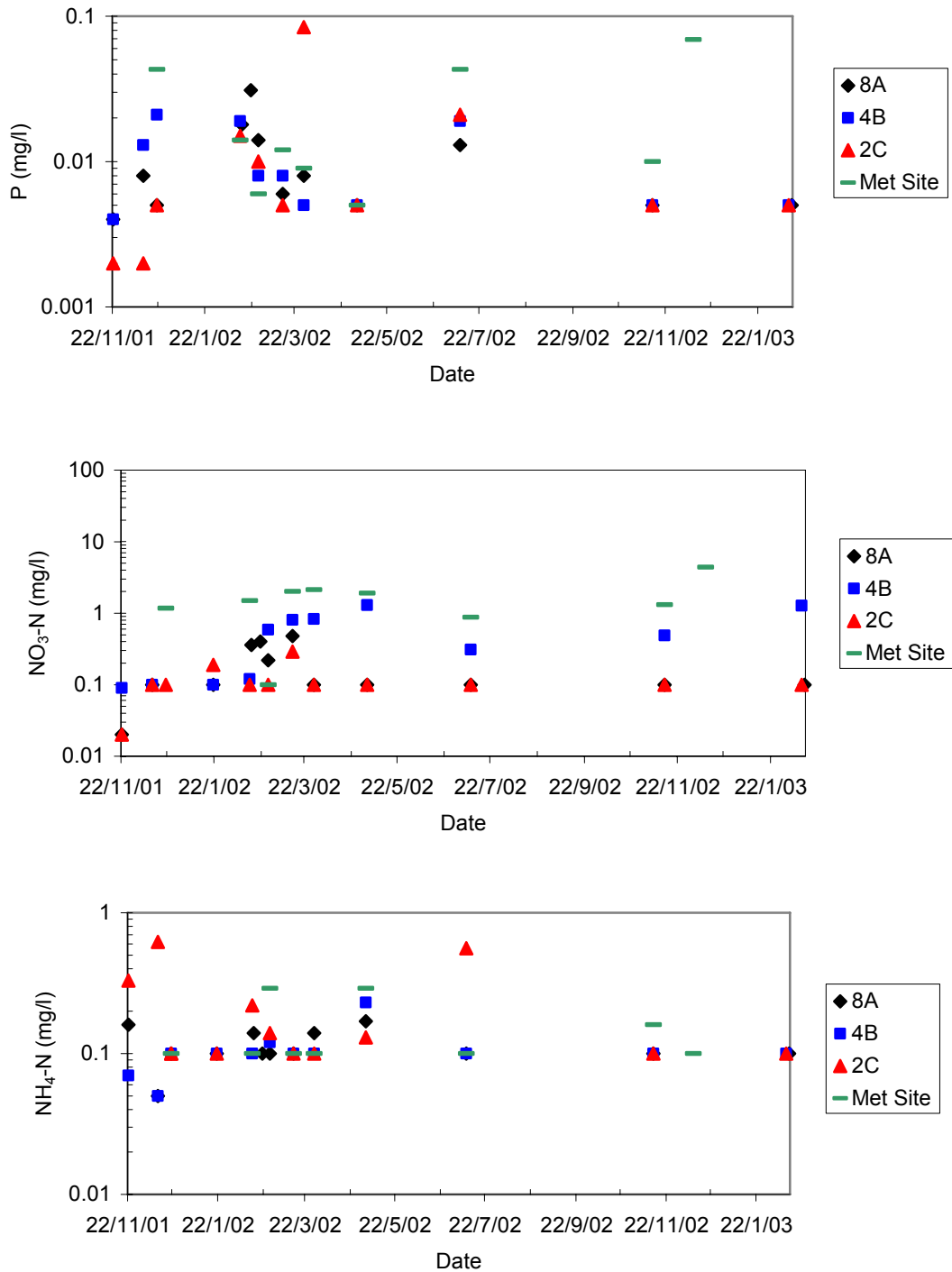

Figure 22: Full-scale earth-banked tank and meteorological site groundwater quality

Water level data

The temporal variation in groundwater level during the monitoring period is presented in Figure 23.

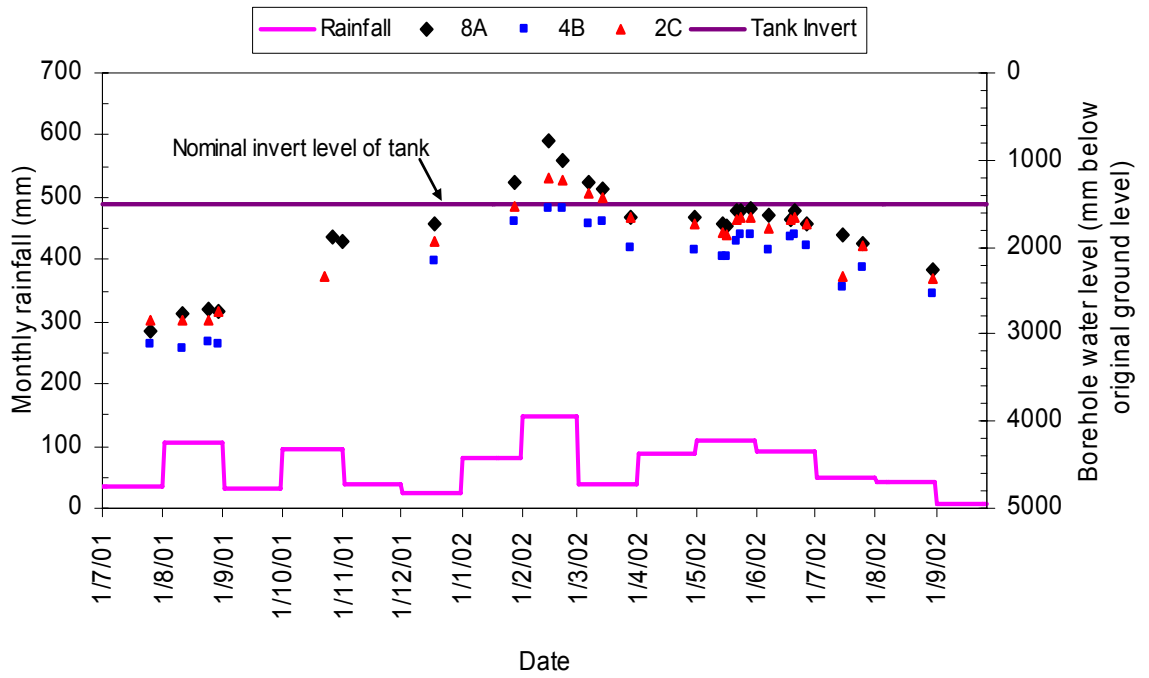

Figure 23: Water levels in aquifer for boreholes 8A, 4B and 2C

Slurry infiltration measurement

Monthly evaporation, tank level change and rainfall data, following the filling of the tank with slurry are presented in Figure 24. The sign convention in Figure 24 should be noted: + indicates a drop in tank level, - indicates a rise in tank level.

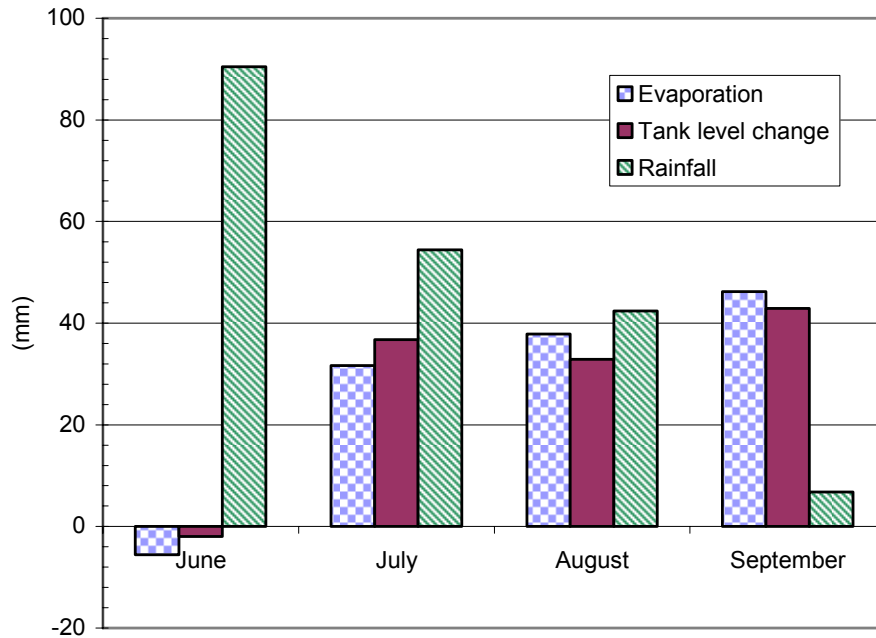

Figure 24: Monthly rainfall, class A pan evaporation and tank level changes (for year 2002) following filling of tank

Discussion and conclusions

Examination of Figure 22 shows that no significant deterioration in the quality of the groundwater occurred following the filling of the tank with slurry. In the case of the nitrate parameter, $\text{NO}_3\text{-N}$, the groundwater quality is well within the limit value set down in the Nitrates Directive. Comparison of these results with those obtained from the control boreholes shows that, for all three water quality parameters, the water quality in the control boreholes is generally lower than results obtained from the boreholes around the earth-banked tank.

Examination of Figure 23 shows that the groundwater level followed an expected seasonal pattern being at its highest in mid-February. Except for the months of February and March, the groundwater table was at all times below the invert of the tank. The significance of the level of the groundwater table in this case is that it might be expected that a deterioration in groundwater quality would occur once the level of the groundwater table exceeded the tank invert level. However, when the groundwater level data in Figure 23 is examined in conjunction with groundwater quality data in Figure 22, it is clear that the level of the groundwater table has no discernible influence on the quality of the groundwater.

Examination of Figure 24 shows that, although the absolute magnitudes of average monthly evaporation rates and tank level changes are significant, the relative differences between the two parameters are small and it is difficult to draw any definitive conclusions regarding the net slurry infiltration (tank level change – evaporation). For example, the month of July shows a small net infiltration whereas the data for August shows a small net exfiltration (physically implausible). The monthly differences can be attributed to:

- Difficulty in relating class A pan evaporation measurements to a much larger body of open slurry;
- The formation of a biological layer on the slurry surface as a result of the flotation of bio-solids to the surface, which is likely to have inhibited evaporation from the slurry;
- Differences in the rate of evaporation of clean water (from the class A pan) and the rate of evaporation of slurry (from the tank).

EXPERIMENT 5: PILOT-SCALE FIELD TESTS

Introduction

Difficulties were encountered in estimation of infiltration rates from earth-banked tanks using the water balance method. A novel method of direct infiltration measurement method was developed and a pilot-scale earth-banked tank constructed to investigate the methodology.

Design of pilot-scale earth-banked tank

The design for the pilot-scale earth-banked tank is based on the full-scale construction but an underdrainage collection system is constructed beneath the compacted subsoil liner. In addition, the underdrainage system is hydrologically isolated from the surrounding environment by means of an impermeable layer of plastic sheeting. It was also necessary to ensure that the system had a control so drainage pipes were installed around the footprint of the pilot-scale tank and also beneath the hydrologically isolated underdrainage system. It was considered that this novel system would enable the rate of slurry infiltration through the soil to be more directly measured, particularly in light of the difficulties encountered in estimating the infiltration rates from the full-scale earth-banked tank by the water balance method in Experiment 4.

Construction of pilot-scale earth-banked tank

The site was excavated to a depth of approximately 3.5m. A shallow land drain was installed in the centre and at the periphery of the excavation. The drains were backfilled with ~20mm diameter washed rounded stone. The pilot-scale tank was then constructed such that effluent flowing through the compacted subsoil base of the tank was collected by an underdrainage collection system, consisting of a perforated pipe surrounded by granular material, underlain by an impermeable membrane. The compacted subsoil liner was constructed by placing the soil in thin layers (~200mm) thick and compacting each layer using a 20 tonne tracked hydraulic excavator. Four passes per layer resulted in subsoil layer of low permeability. Three such layers resulted in a compacted subsoil liner 0.5 m thick. The pilot-scale tank was constructed at half the vertical scale of the full-size tank, although the hydraulic gradient through the soil was maintained the same in both cases. In the full-scale tank, 3 m of slurry overlies 1 m of impermeable soil, whereas in the pilot-scale tank 1.5 m of slurry overlies 0.5 m of impermeable soil, thus maintaining the same hydraulic gradients. Sections through the pilot tank are shown in Figure 25.

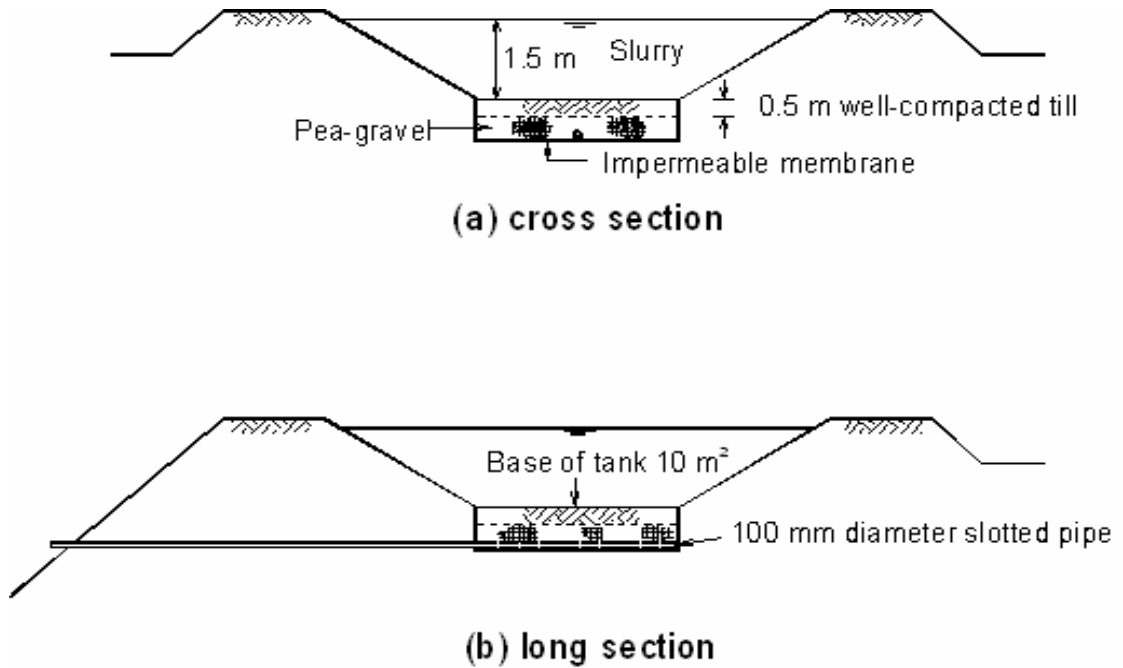

Figure 25: Sections through pilot-scale earth-banked tank

Slurry infiltration and effluent quality measurement

Flow rate through the base of the tank was measured volumetrically and the quality of the effluent collected was routinely monitored. The change in the infiltration rate through the base of the tank (equivalent monthly flow rate/tank base area) following the filling of the tank is presented in Figure 26 and some relevant effluent quality data is presented in Figure 27.

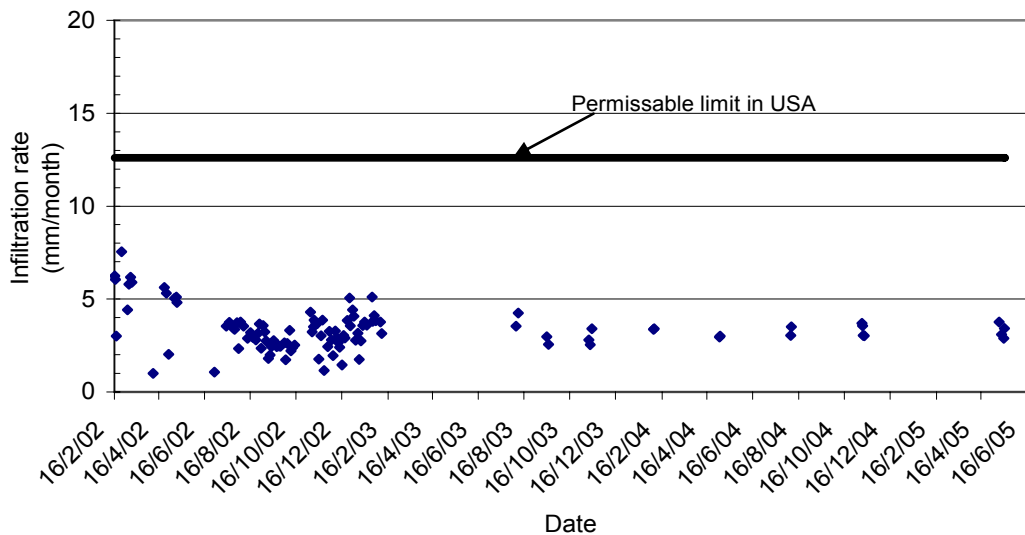

Figure 26: Slurry infiltration rate through base of pilot-scale earth-banked tank

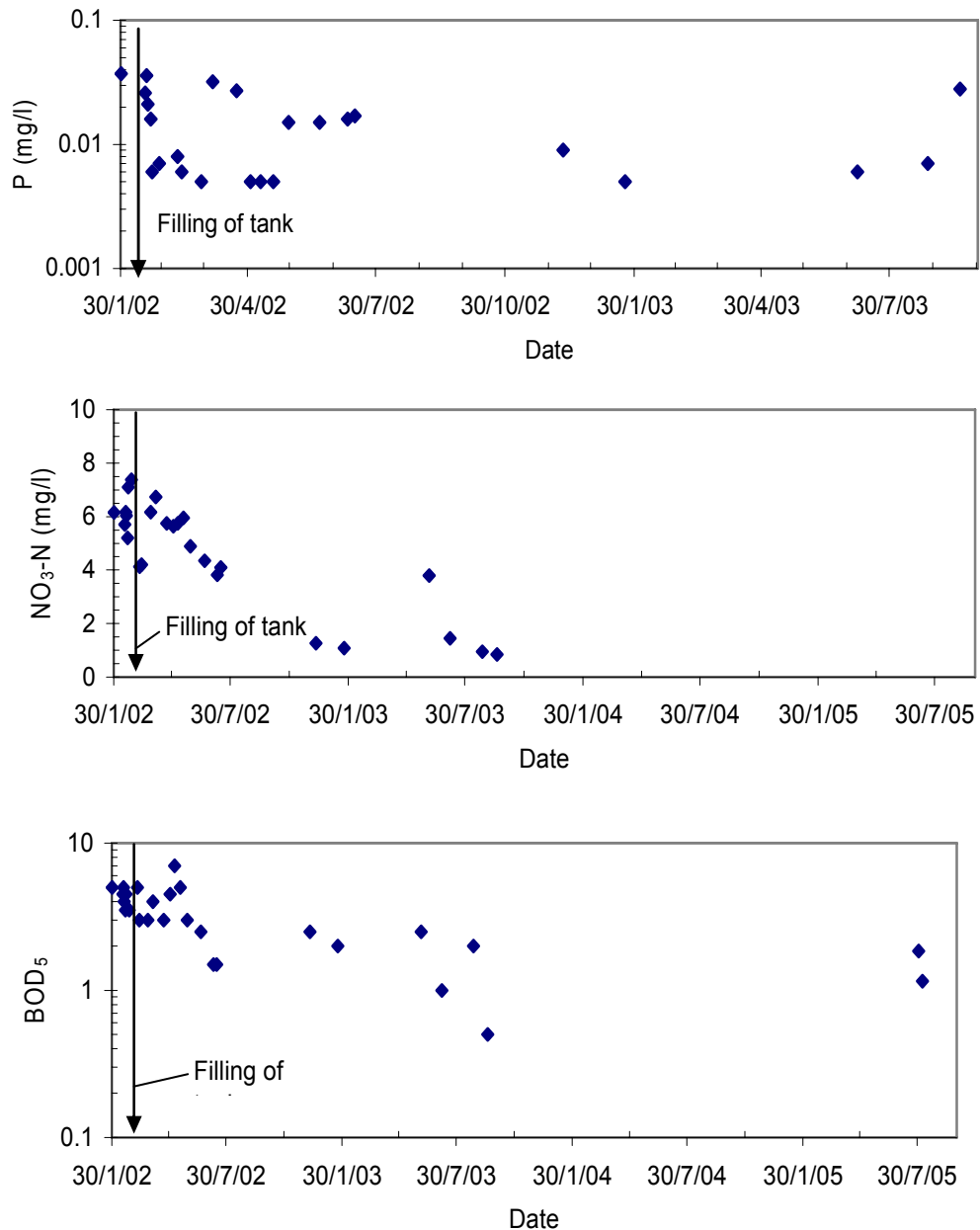

Figure 27: Effluent quality from pilot-scale earth-banked tank

Discussion

Examination of Figure 26 shows that the slurry infiltration rate was significantly below acceptable limits and declined with time, indicative of a sealing of the pores of the soil due to the deposition of bio-solids. The corresponding effluent quality parameters shown in Figure 24 indicate that the quality of the effluent is also well within permissible limits. For example, the BOD₅ values of less than 10 mg/l are significantly below the permissible value of 25 mg/l in the urban wastewater treatment directive; the NO₃⁻N concentrations of less than 8 mg/l meet the requirement of the nitrates directive and the P concentrations of less than 0.1 mg/l are significantly below the 1 mg/l limit of the urban wastewater treatment directive for sensitive waters. The groundwater quality results in the vicinity of the pilot-scale earth-banked tank exceeded what might reasonably have been expected based upon the literature review (Sewell 1978, Miller et al. 1985 etc.). The literature suggested that a deterioration in groundwater quality was likely to occur immediately

after filling of the tank and that gradually, the groundwater quality would improve due to the sealing effect of the slurry on the soil liner. Examination of groundwater quality data in the vicinity of the pilot-scale earth-banked tank showed no discernible deterioration in quality (see Figure 24).

Conclusions

The direct method of measuring the slurry infiltration rate from an earth-banked tank proved to be much more reliable than the indirect method of measurement by a water balance. The performance of the pilot-scale earth-banked tank, as measured by the infiltration rate of the slurry, gradually improved because of the base and the sides of the tank being sealed by the deposition of biosolids.

EXPERIMENT 6: DEVELOPMENT OF A SLURRY SOIL MODEL

Introduction

Experiments 3, 5 and 6 all indicated that the application of animal slurry to a soil significantly reduces the effective permeability of that soil. Permissible seepage rates for subsoils used to construct earth-banked tank subsoil liners are normally specified on the basis of the flow of clean water through the containing subsoil liner and are therefore conservative since the sealing effect due to the contained solids in the liquid flowing is generally ignored. The primary (short term) sealing mechanism of such solids is generally considered to be physical blocking of the soil pores, while a secondary (long term) mechanism is due to the development of a biofilm on the surface of the soil liner.

As a result of the experiments conducted during this project it was considered necessary to develop a methodology for describing the primary sealing mechanism referred to above. The methodology is based on coupling laboratory analysis of the contained fluid (animal slurry) with a predictive model of the transport process.

The proposed methodology involves the application of the 'Specific Resistance to Filtration' (SRF) laboratory test, commonly used to assess the dewaterability of water and wastewater sludges, to the animal slurry. The SRF test would characterise the hydraulic resistance offered by the solids 'cake' formed on the soil surface by the suspended solids contained in the animal slurry. A predictive model of the soil sealing process would then incorporate the SRF value of the animal slurry into a mathematical model of the flow hydraulics under the following conditions: falling head, constant head and rising head.

Flow hydraulics

The flow of a liquid through a porous medium such as soil is described by Darcy's law (Darcy, 1856). In the case of the flow of suspensions such as animal slurry through soil it has been well established, both in full-scale trials (Culley et al, 1982) and in laboratory studies (Purcell et al., 2001) that animal slurries in contact with soil do cause a progressive sealing of the soil with time, thereby significantly reducing the effective permeability of the soil. The laboratory measurement of the permeability of porous media at very low values presents significant difficulties for conventional laboratory geotechnical equipment, such as the permeameter or manually operated triaxial apparatus, and requires the use of sophisticated computer-controlled apparatus. However, animal slurries are unsuitable for use in such apparatus due to problems with clogging of lines and potential damage to sensors. To overcome these difficulties, the authors adapted the specific resistance to filtration (SRF) apparatus (Coackley and Jones, 1956) used in the laboratory assessment of the dewaterability of water and wastewater treatment sludges to study the flow of animal slurry through porous media. The adapted SRF test has been described in Experiment 3.

Model development

The objective of the model is to quantify the extent of the reduction in the seepage rate caused by the formation of a bio-solids 'cake' on the surface of the soil liner. A preliminary one-dimensional model of the flow of a suspension through an 'impermeable' soil (e.g. clay), modelled as a semi-permeable membrane, has been developed for the cases of (a) falling head, (b) rising head and (c) constant head.

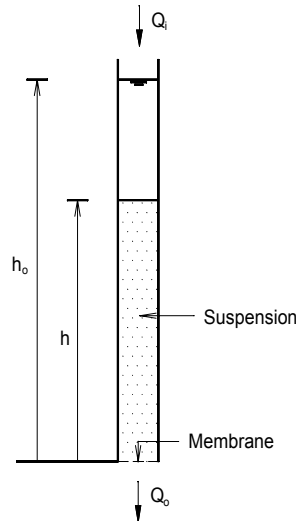

Figure 28: Flow of a suspension through a semi-permeable membrane

Falling head

Consider a column of the suspension, of plan area A , flowing through a semi-permeable membrane under an initial head (h_0). Referring to Figure 30 in this case there is no inflow (Q_i) and the outflow (seepage) is Q_o . If the initial fluid head is h_0 , after time t the head will have fallen to a height h (see Figure 28).

The volumetric flow rate $\left(\frac{dV}{dt}\right)$ at any time t is given by the expression:

$$\frac{dV}{dt} = \frac{PA}{\mu R} \quad (1)$$

where:

V = volume of filtrate in time t ,

P = pressure across the membrane,

μ = dynamic viscosity of fluid flowing,

R = resistance of solids 'cake' formed on surface of membrane.

Hence:

$$\frac{dV}{dt} = \frac{PA}{\mu \frac{rcV}{A}} \quad (2)$$

where:

r = specific resistance to filtration of the solids 'cake',

c = solids concentration in the suspension.

Re-writing Equation (2):

$$PA^2 dt = \mu rcVdV \quad (3)$$

Now:

$$P = \rho gh \quad (4)$$

where:

ρ = fluid density

g = acceleration due to gravity.

$$V = (h_o - h)A \quad (5)$$

$$dV = -Adh \quad (6)$$

Substituting Equations (4), (5) and (6) into (3) yields:

$$\rho ghA^2 dt = \mu rc(h_o - h)A(-Adh) \quad (7)$$

$$\rho gh dt = \mu rc(h - h_o)dh \quad (8)$$

The seepage rate ($Q_o = -A \frac{dh}{dt}$) is therefore given by the expression:

$$Q_o = \frac{\rho g A}{\mu r c} \left(\frac{h}{h_o - h} \right) \quad (9)$$

Constant head

For constant head (h_o), Equation (4) becomes: $P = \rho gh_o$, which, together with Equations (5), (6) and (3), yields:

$$\rho gh_o dt = \mu rc(h - h_o)dh \quad (10)$$

$$\text{Hence the seepage rate } Q_o = \frac{\rho g A}{\mu r c} \left(\frac{h_o}{h_o - h} \right) \quad (11)$$

Rising head

Referring to Figure 28, for this case, the inflow (Q_i) must exceed the outflow (Q_o). Assume that it is required to calculate the rate of inflow to maintain the outflow at some specified constant value (Q_o):

$$Q_o = \frac{dV}{dt} = \frac{PA}{\mu \left(\frac{rcV}{A} \right)} = \frac{PA^2}{\mu r rcV} \quad (12)$$

Substituting Equation (4) into (12) and noting that, for a constant outflow rate Q_o , $V = Q_o t$:

$$Q_o = \frac{\rho ghA^2}{\mu rc(Q_o t)} \quad (13)$$

$$h = \frac{\mu rc Q_o^2 t}{\rho g A^2} \quad (14)$$

$$\begin{aligned} \text{Rate of change of interface} &= \frac{dh}{dt} \\ &= \frac{\mu rc Q_o^2}{\rho g A^2} \end{aligned} \quad (15)$$

$$= \frac{Q_i - Q_o}{A} \quad (16)$$

Equating (15) & (16):

$$Q_i - Q_o = \frac{\mu r c Q_o^2}{\rho g A} \quad (17)$$

$$Q_i = Q_o + \frac{\mu r c Q_o^2}{\rho g A} \quad (18)$$

Model equations

The equations for each of the three cases are given below and illustrated in Figure 29.

Equation 9 Falling Head

$$Q_o = \frac{\rho g A}{\mu r c} \left(\frac{h}{h_o - h} \right)$$

Equation 10 Constant Head

$$Q_o = \frac{\rho g A}{\mu r c} \left(\frac{h_o}{h_o - h} \right)$$

Equation 11 Rising Head

$$Q_i = Q_o + \frac{\mu r c Q_o^2}{\rho g A}$$

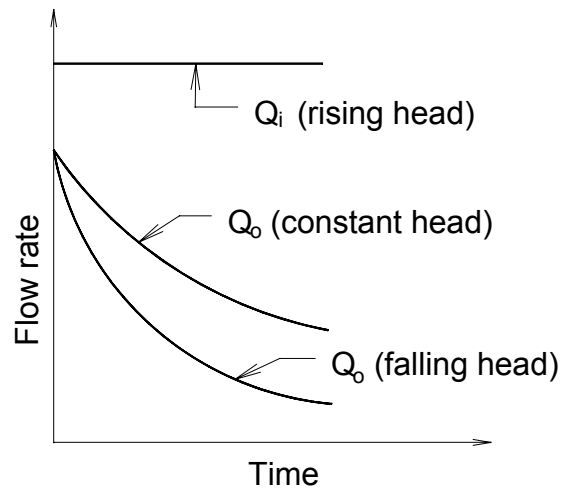

Figure 29: Graphical representation of seepage rate for rising, constant and falling head.

Examination of Figure 29 shows the reductions in the seepage rate in the constant and falling head cases arising from the sealing of the soil surface due deposition of bio-solids, the former exhibiting the greatest deceleration in flow rate. The rising head model enables the computation of the rate at which liquid waste should be

added to the tank to ensure that the rate of seepage from the base of the tank is maintained within a permissible limit.

Preliminary model validation

Introduction

Preliminary experimental testing of the mathematical model described above was undertaken for the falling head case described by Equation 9.

Materials and methods

Beef cattle slurry was obtained from an underfloor slatted shed slurry tank at Teagasc Grange Beef Research Centre. The sample was diluted with distilled water, generating three suspensions of varying solids contents (see Table 20).

SAMPLE NAME	TOTAL SOLIDS
	kg/m ³
Suspension A	11.59
Suspension B	2.16
Suspension C	1.11

Table 20: Total solids content of three test suspensions

Standard SRF tests were conducted on the three suspensions in order to determine their specific resistance to filtration. The experimental apparatus is schematically illustrated in Figure 30.

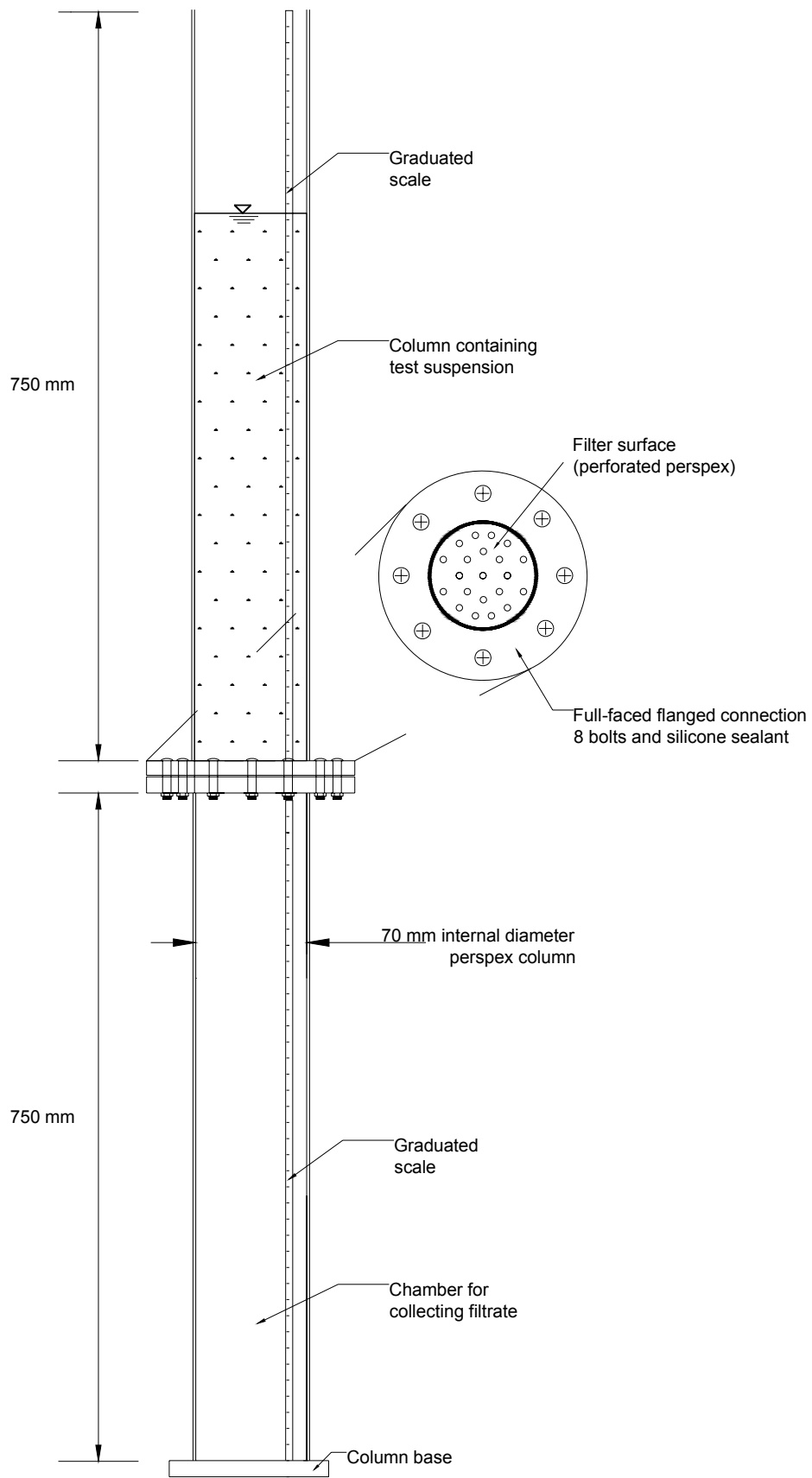

Figure 30: Schematic of experimental apparatus

A filter paper (Whatman No. 1) was placed between the flange plates over a perforated perspex mesh which formed the filter membrane. A graduated scale on the side of the test column enabled suspension height above the membrane be recorded. Each of the test suspensions was poured into the test column in turn and suspension height above the membrane and filtrate volumes were recorded at regular time intervals.

Results

Three SRF tests were conducted on each test suspension. The 'r' values as computed by the SRF tests conducted on the three test suspensions are summarised below:

SUSPENSION	'r' VALUE
	m/kg
A	2.34×10^{15}
B	5.72×10^{15}
C	6.35×10^{15}

Table 21: SRF 'r' values for test suspensions

Two column tests were conducted on each test suspension; one with an initial head (h_0) of approximately 55 mm and the other with an initial head (h_0) of approximately 27 mm. Predicted flow rates for each of the suspensions were calculated using the equations derived for the falling head model (Equation 9).

This exercise was repeated for all six tests and the flow rates obtained from both the experimental tests and the model are presented below. In the graphical presentation in Figure 31, the data has been transformed by multiplying all flow rate data by 10^{10} for reasons of clarity. Therefore,
 EXPERIMENT = experimental filtrate flow rate $\times 10^{-10}$ (m^3/s),
 MODEL = filtrate flow rate as predicted by model $\times 10^{-10}$ (m^3/s).

Suspension A ($h_0 = 0.0571$ m)

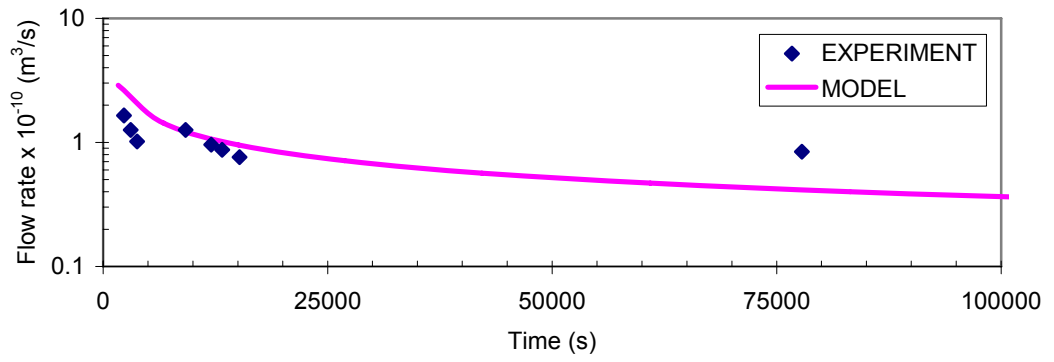

Suspension A ($h_0 = 0.0206$ m)

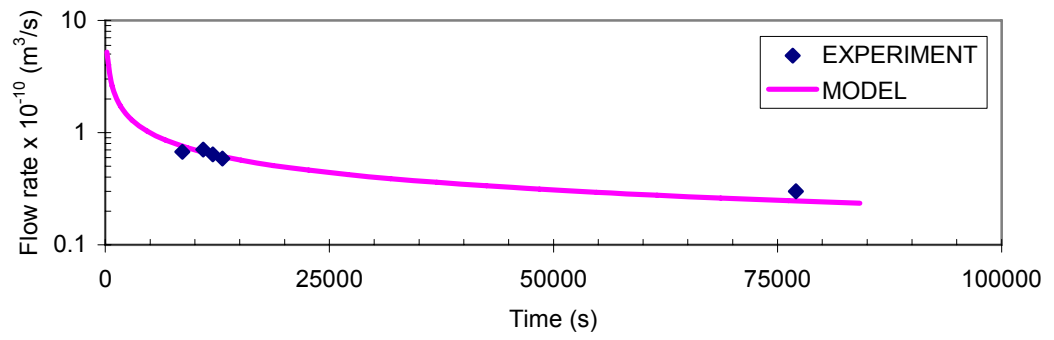

Suspension B ($h_0 = 0.0561$ m)

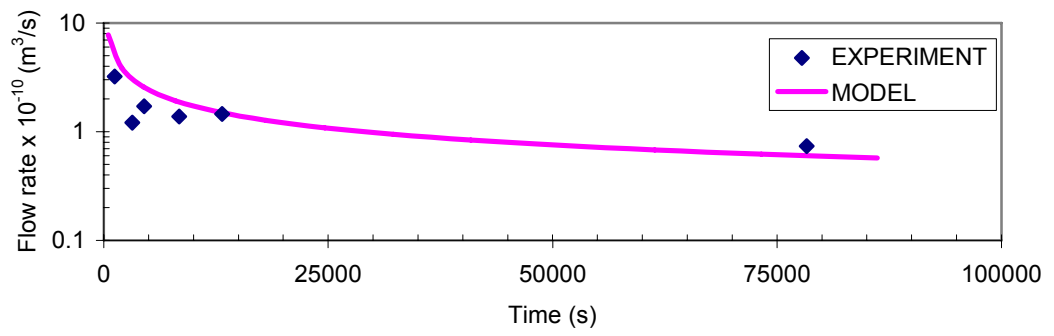

Suspension B ($h_0 = 0.0205$ m)

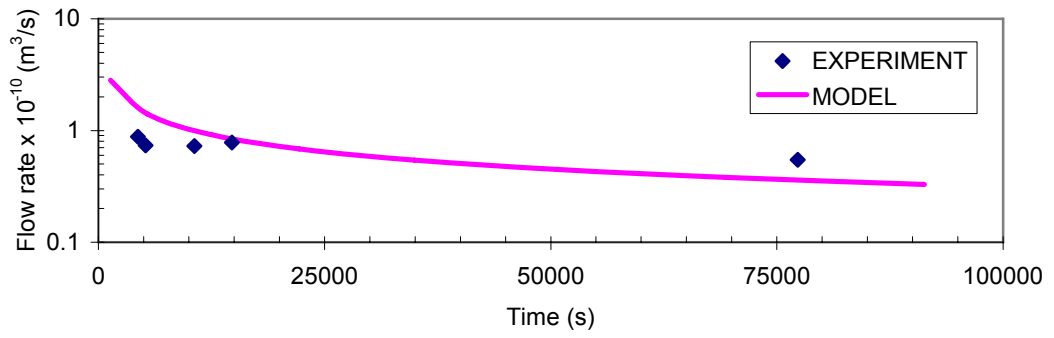

Suspension C ($h_0 = 0.0557$ m)

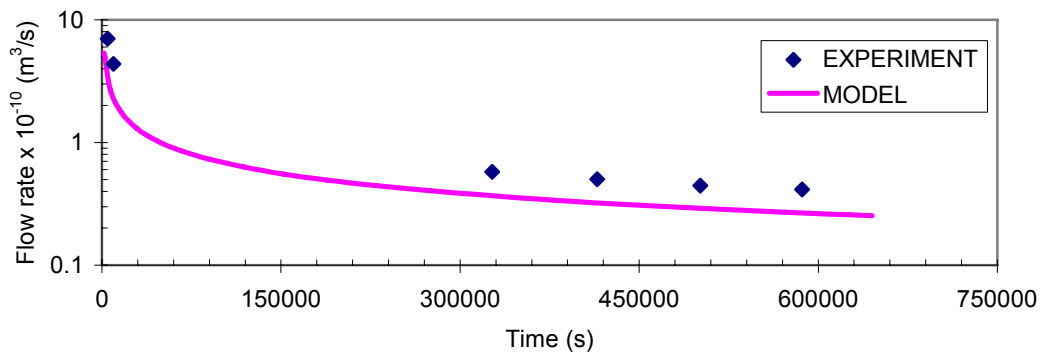

Suspension C ($h_0 = 0.0226$ m)

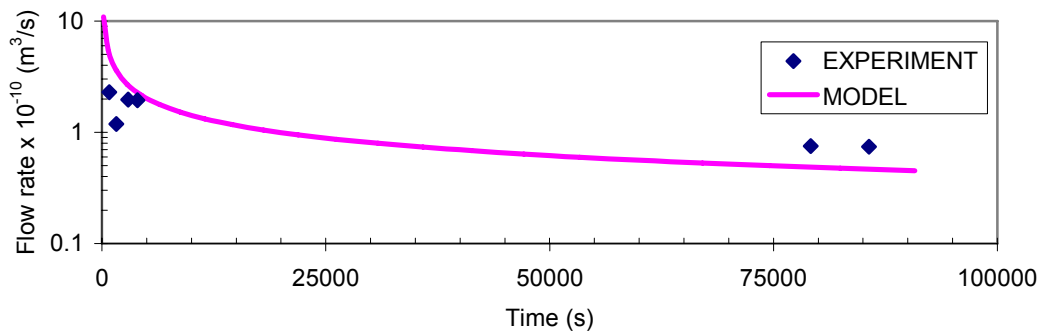

Figure 31: Experimentally derived and calculated flow rates for suspensions A, B and C.

Worked example

The foregoing model developed to describe the soil sealing process is applied to a worked example of an earth-banked tank. The tank contains animal slurry (suspension), is constructed using impermeable soil, and the structure is underlain by a permeable subsoil layer. A profile through the structure is illustrated in Figure 32.

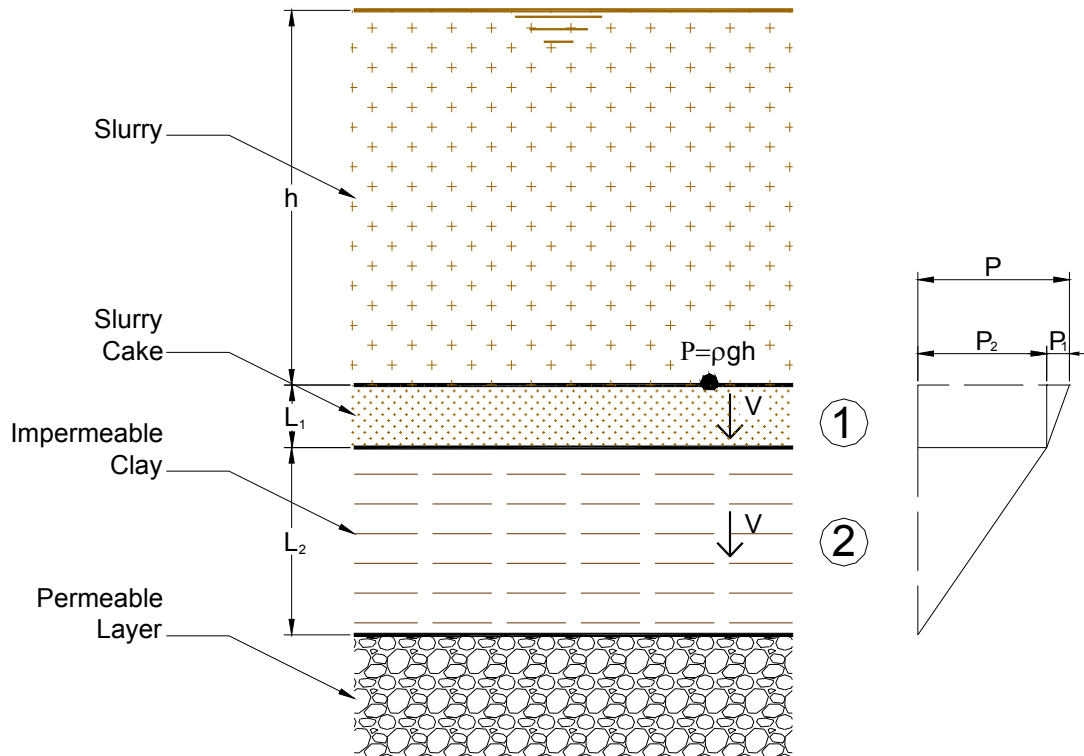

Figure 32: Profile through earth-banked slurry storage tank

The following parametric values which may be considered typical of earth-banked tanks, are applied in the model:

h_0 = depth of suspension in tank = 3.0 m,

L_2 = thickness of compacted subsoil layer = 1.0 m,

μ = suspension dynamic viscosity = 0.0011 Ns/m²,

ρ = suspension density = 1000 kg/m³,

k = compacted subsoil liner hydraulic conductivity = 1×10^{-9} m/s,

c = suspension solids concentration = 11.59 kg/m³,

r = specific resistance to filtration 'r' value for suspension = 2.34×10^{15} m/kg,

g = acceleration due to gravity = 9.81 m/s².

The application of the model is developed in two stages:

(a) Model applied without any soil liner i.e. seepage through the cake only;

(b) Model applied with soil liner i.e. seepage is through both cake and soil liner.

The equations relevant to the case are summarised below:

Case (a): seepage through cake only

$$P = \rho gh_0$$

$$Q = \frac{\rho g A}{\mu r c} \left(\frac{h_0}{h_0 - h} \right)$$

$$t = \frac{\mu r c}{\rho g} \left(\frac{1}{2h_0} (h^2 - h_0^2) + h_0 - h \right)$$

By selecting a range of values for time (t) i.e. t=0 s to t = 2 yr, corresponding head (h) values can be calculated and hence the seepage velocities (v). The seepage velocity graph for the suspension cake is plotted in Figure 33 and a sample calculation presented below.

Let t = 3600 s (1 hr)

Substituting in values for μ , r, c, ρ and h_0

$$\Rightarrow 3600 = \frac{(0.0011)(2.34 \times 10^{15})(11.59)}{(1000)(9.81)} \left[\frac{1}{2 \times 3.0} (h^2 - 3.0^2) + (3.0 - h) \right]$$

$$\Rightarrow h = 2.9991\text{m}$$

The corresponding value for v is then calculated as follows:

$$\frac{Q}{A} = v = \frac{\rho g}{\mu r c} \left(\frac{h_0}{h_0 - h} \right) = \frac{(1000)(9.81)}{(0.0011)(2.34 \times 10^{15})(11.59)} \left(\frac{3.0}{3.0 - 2.9991} \right) = 1.144 \times 10^{-6} \text{ m/s}$$

Seepage rate (suspension cake)

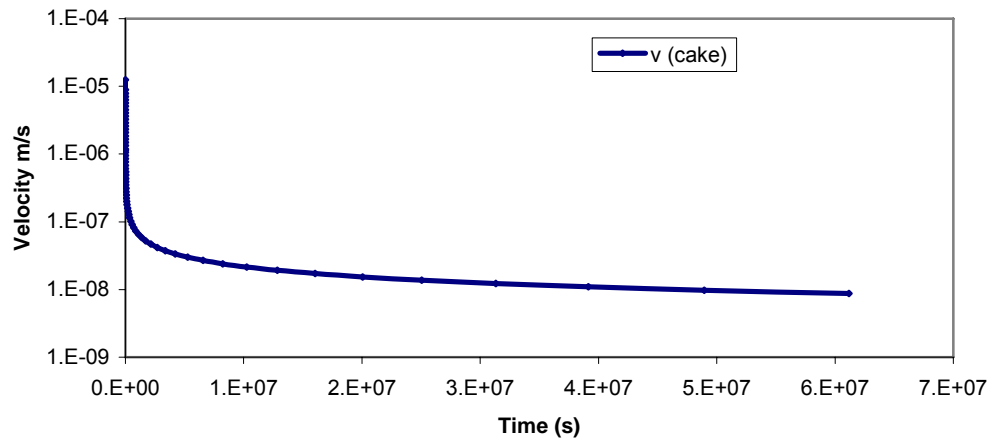

Figure 33: Calculated seepage rate through suspension cake without soil liner

Case (b): seepage through cake with soil liner

Referring to Figure 32, the total pressure drop (P), equals the sum of the pressure drop through the cake (P_1) plus the pressure drop (P_2) through the soil liner.

$$P = P_1 + P_2$$

$$\text{and } v = ki$$

$$\Rightarrow Q = \frac{PA}{\mu R}$$

$$\Rightarrow v = \frac{P}{\mu R}$$

$$\Rightarrow P = (v)(\mu R_1) + (v)(\mu R_2)$$

$$\therefore v = \frac{P}{\mu [R_1 + R_2]}$$

$R_1 = rcV$ where V = cumulative volume of filtrate at time t (variable) and

$$R_2 = \frac{\rho g L_2}{\mu k} \text{ (a fixed value).}$$

Therefore in order to calculate $v_{\text{(cake + soil liner)}}$, V must first be calculated for each time t .

$$V_t = h_0 - h_t$$

For example, after time (t) = 3600 s, h has been calculated as 2.9991 m.

$$\text{Therefore } V_{3600} = 3.0 - 2.9991 = 0.0009 \text{ m}^3$$

$$R_1 = rcV = (2.34 \times 10^{15})(11.59)(0.0009) = 2.44 \times 10^{13}$$

$$R_2 = \frac{\rho g L_2}{\mu k} = \frac{(1000)(9.81)(1.0)}{(0.0011)(1 \times 10^{-9})} = 8.92 \times 10^{15}$$

$$P = \rho g h_0 = (1000)(9.81)(3.0) = 29430$$

Therefore;

$$v_{\text{(cake+liner)}} = \frac{(29430)}{0.0011 \left[(2.44 \times 10^{13}) + (8.92 \times 10^{15}) \right]} = 2.99 \times 10^{-9} \text{ m/s}$$

This calculation was repeated for a series of time increments and is plotted in Figure 34 together with $v_{\text{(cake)}}$ and a typical permissible seepage rate $v_{\text{(typical permissible)}}$ where;

$$v_{\text{(typical permissible)}} = ki = (1 \times 10^{-9}) \times \left(\frac{3+1}{1} \right) = 4 \times 10^{-9} \text{ m/s}$$

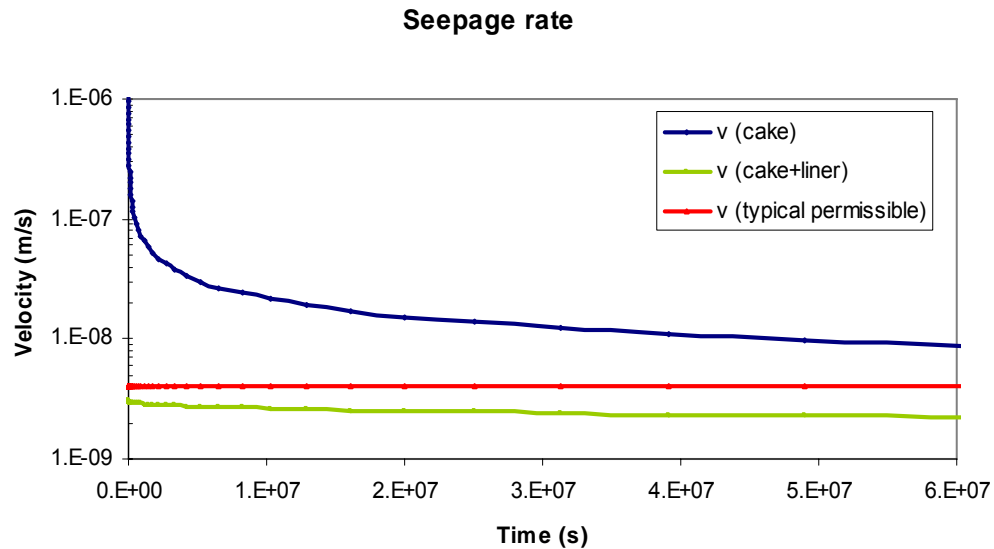

Figure 34: Calculated seepage rates from earth-banked slurry tank

Examination of Figure 34 shows that the formation of a solids cake alone is insufficient to maintain seepage rates below a typical permissible value of 4×10^{-9} m/s. However, when the cake resistance is coupled with the resistance to flow offered by the soil liner, the seepage rates are less than typical permissible values.

Regulatory authorities normally require that the soil lining an earth-banked tank be sufficiently impermeable to maintain seepage rates below permissible values. This approach is very conservative, neglecting as it does the resistance offered to flow by the formation of the solids cake. The methodology developed above enables the sealing effect of the cake to be considered at the design stage. The models developed enable a sensitivity analysis of the input parameters to be conducted.

Discussion and conclusions

Points of discussion with respect to the model validation exercise are listed below:

- (i) The model predictions and the experimental data follow the same general trend i.e. an initial rapid drop off in the seepage (flow) rate as the cake seal forms, followed by a more gradual reduction in flow;
- (ii) Different 'r' values were obtained for suspensions A, B and C. Since the specific resistance to filtration 'r' is defined as the hydraulic resistance of a cake having unit mass of dry solids per unit area of filtration surface it was expected that the 'r' values would be the same for each of the test suspensions since the 'r' value is theoretically independent of suspended solids concentration. Although the 'r' values obtained for suspensions A, B and C are of the same order of magnitude, they are not the same (see Table 21). Similar findings have been reported by Coackley and Jones (1956) where 'r' values were found to decrease with decreasing solids content;
- (iii) The SRF test was conducted at a vacuum pressure of 0.5 bar (50 kPa) whereas the column validation tests were conducted at smaller positive pressures of between 0.0024 bar to 0.0053 bar (0.24 kPa to 0.53 kPa). Theoretically, the 'r' value determined should be invariant of the pressure applied across the membrane, but in reality the applied pressure does have an effect (Ryan,

personal communication), higher pressure is likely to compress the solids matrix to a greater extent, thereby increasing the resistance to flow.

The model developed above assumes that the solids 'cake' formed on the surface of the membrane results from physical flow (advection) through the membrane and that there is no sedimentation of solids onto its surface. In addition, the resistance of the soil through which the permeate would, in reality, flow is neglected for the purpose of developing a simple model of the transport process. Both the soil resistance and sedimentation of the solids could easily be incorporated to produce a more realistic model.

A methodology which involves the laboratory measurement of the specific resistance to filtration of an animal slurry coupled with a mathematical model enables the reduction in seepage due to the solids contained in an animal slurry to be estimated. The methodology has been tested for the falling head case using three suspensions (beef cattle slurry of varying suspended solids contents). The proposed model may be useful to regulatory authorities, enabling an estimate of the likely extent of soil sealing by suspensions flowing through soils and subsoil liners to be made.

CONCLUSIONS

Literature review

- Low permeability fine-grained soils are required for construction of a successful earth-banked tank without the need for compacted subsoil liner;
- The formation of a slurry-soil seal in an earth-banked tank significantly reduces the seepage rate from the tank over time;
- Soil texture and/or plasticity should be considered in addition to hydraulic conductivity when a soil's suitability is being assessed for earth-banked tank construction;
- Existing standards take a broadly similar approach, typically, specifying that:
 - a site investigation be undertaken,
 - that the tank be constructed so that it is 'impermeable',
 - that embankments have a minimum top width with strict limits on bank slopes,
 - that a minimum depth to groundwater is specified,
 - that all health and safety requirements particular to that country be adhered to.

Laboratory experiments

- Basic soil tests such as particle size distribution and Atterberg limits give a good indication of the suitability of the soils for lining municipal leachate or agricultural slurry containment facilities;
- The presence of suspended solids in the slurry had a pronounced sealing effect on the soil liner, significantly reducing the effective permeability of the soil due to the deposition of solids on the soil surface and within the pores of the soil;
- Under relatively high pressures (~ 10.3 m head), animal slurry of low total solids content (1.5 %) had the ability to almost completely seal a column of sand after a relatively short period of time;
- Animal slurries do form a seal on soil, and if this effect is accounted for in the design of earth-banked tanks, then the risk of excessive seepage is minimal.

Field work

- The full-scale earth-banked tank constructed at Teagasc Grange Beef Research Centre had no significant effect on the groundwater quality around the tank footprint;
- The level of the groundwater table had no discernible influence on the quality of the groundwater in the vicinity of the earth-banked tank;
- The direct method of measuring slurry infiltration proved to be much more reliable than the indirect method of measurement by a water balance calculation;
- The quality of the effluent sampled directly beneath the pilot-scale earth-banked tank was well within permissible limits.

Modelling work

- Conceptual models for the various field conditions of seepage flow from open channels and impoundments could be used to describe the conditions encountered for earth-banked slurry storage tanks;
- A worked example of a practical application of the model has been presented.

General

Although earth-banked tanks have been widely used throughout the world as an effective means of slurry storage (Parker et al. 1999), (Davis et al. 1973), (CIRIA 126 1992), (AWMFH 1999 etc.), their possible incorporation into an Irish farming context has never previously been examined in detail. The conclusion of this study is that well-constructed earth-banked tanks using suitable soil that is adequately compacted can be successfully used to temporarily store highly polluting liquids such as animal slurries. The enhanced slurry-storage capacity resulting from the use of earth-banked tanks should reduce the pressure on farmers to spread slurry on land at inappropriate times, thereby contributing to an improvement in the quality of watercourses adjacent to agricultural activities.

REFERENCES

- ADAS. 2000. Earth-banked slurry stores-guidance on construction, repair and maintenance. Note No. CGN-002. ADAS National Building Design Team and Ministry for Agriculture, Fisheries and Food (MAFF), United Kingdom.
- Benson, C.H., Huaming Zhai, and Xiaodong Wang. 1994. Estimating hydraulic conductivity of compacted clay liners. *Journal of Geotechnical Engineering*, ASCE, 120, 2, American Society of Civil Engineers.
- British Standards Institution. 1999. Code of practice for site investigations. BS 5930, BSI, United Kingdom.
- British Standards Institution. 1993. Buildings and structures for agriculture-Part 50: Code of practice for design, construction and use of storage tanks and reception pits for livestock slurry. BS 5502: Part 50. BSI, United Kingdom.
- Casagrande, A. 1948. Classification and Identification of Soils; Transactions of the American Society of Civil Engineers, ASAE, 113, 901 -991.
- Chang, A.C., W.R. Olmstead, J.B. Johanson, and G. Yamashita. 1974. The sealing mechanism of wastewater ponds. *J. Water Pollution Control Fed.*, 46, 7, 1715-1721.
- Coackley, P., and B.R.S. Jones. 1956. Vacuum Sludge Filtration. *Sewage and Industrial Wastes*. 28, 8, 963-976.
- Culley, J.L.B., and P.A. Phillips. 1982. Sealing of soils by liquid cattle manure. *Canadian Agric. Engng.*, 24, 2, 87-89.
- Darcy, H. 1856. *Les Fontaines Publiques de la Ville de Dijon*. Dalmont, Paris
- Davis, S., W. Fairbank, and H. Weisheit. 1973. Dairy waste ponds effectively self-sealing. *Transactions of the ASAE*, 16, 1, 69-71.
- Environmental Protection Agency. 2000. *Landfill Manuals ~ Landfill Site Design*, EPA, Johnstown Castle Estate, Wexford, Ireland.
- Glanville, T.D., J.L. Baker, S.W. Melvin, and M.M. Agua. 2001. Measurement of leakage from earthen manure structures in Iowa. *Transactions of the ASAE*, 44, 6, 1609-1616.
- Ham, J.M. 2002. Seepage losses from animal waste lagoons: A summary of a four year investigation in Kansas. *Transactions of the ASAE*, 45, 4, 983-992
- Hazen, A. 1892. Some physical properties of sands and gravels with special reference to their use in filtration. Document No. 34, Annual Report, Massachusetts State Board of Health, 541-555.
- Head, K.H. 1997. *Manual of soil laboratory testing: Volumes 1, 2 and 3*. Pentech Press, London.
- Hills, D.J. 1976. Infiltration characteristics from anaerobic lagoons. *J. Water Pollution Control Fed.*, 48, 4, 695-709.
- Lambe, T.W., and R.V. Whitman. 1979. *Soil Mechanics (S.I. version)*. John Wiley and Sons, New York.
- Mason, P.A. 1992. Farm waste storage – guidelines for construction. Report No. 126. Construction Industry Research and Information Association (CIRIA), Westminster, London.
- McCullen, P., and M. Long. 1999. Arthurstown landfill facility – geotechnical site characterization. Proc. Seminar on Arthurstown Landfill, Trans. IEI 1998/99, Institution of Engineers of Ireland.
- Miller, M.H., J.B. Robinson, and R.W. Gillham. 1985. Self sealing of earthen liquid manure storage ponds: I. A case study. *J. Environ. Qual.*, 14, 4, 533-538.
- Nordstedt, R.A., L.B. Baldwin, and C.C. Hortenstine. 1971. Multistage lagoon systems for treatment of dairy farm waste. Proc. Int. Symp. on Livestock Wastes, 77-80. ASAE, St. Joseph, Michigan.
- Natural Resource Conservation Service - Wisconsin. 1986. NRCS manure storage Standard 313 and 425, Section IV, Technical Guide. Madison, Wisconsin.

- O'Sullivan, D., and P. Quigley. 2002. Geotechnical engineering and environmental aspects of clay liners for landfill projects. Fehily Timoney & Co. and Irish Geotechnical Services Ltd. Institution of Engineers of Ireland.
- Parker, D.B., D.D. Schulte, and D.E. Eisenhauer. 1999. Seepage from earthen animal waste ponds and lagoons – An overview of research results and state regulations. *Transactions of the ASAE*, 42, 2, 485-493.
- Purcell P., M. Long, H. Scully, and T. Gleeson. 2001. Seepage from landfill sites and from animal waste storage tanks. *Geoenvironmental Engineering*, pp. 477-482. Thomas Telford Publishers.
- Proctor, R.R. 1933. First of four articles on the design and construction of rolled-earth dams. *Fundamental principles of soil compaction*. *Engineering News* 111, 245–248.
- Ryan, R. 2005. (pers. comm.). University College Dublin. Ireland.
- Sewell, J.I. 1978. Dairy lagoon effects on groundwater quality. *Transactions of the ASAE*, 21, 5, 948-952.
- Shaw, E.M. 1996. *Hydrology in Practice*, 3rd edition, Chapman and Hall, London.
- Skempton, A. 1953. The colloidal activity of clay. *Proc. 3rd Int. Conf. on Soil Mechanics and Foundation Engineering*, Butterworth Scientific Publication, London, England, Volume 1, 57-61.
- Terzaghi, K., and Peck, R.B. 1948. *Soil Mechanics in Engineering Practice*. Wiley, New York.
- Westerman, P.W., R.L. Huffman, and J.S. Feng. 1995. Swine lagoon seepage in sandy soil. *Transactions of the ASAE*, 38, 6, 1749-1760.
- World Meteorological Organisation. 1966. *Measurement and Estimation of Evaporation and Evapotranspiration*. Technical Note No. 83, No. 201 TP 105, Reprinted 1968, WMO.

APPENDIX A: PUBLICATIONS

- Scully, H.A. 2000. An evaluation of earth bank tanks for slurry storage. Abstract and Poster. Proc. National Committee for Engineering Sciences Conf. ~ Engineering Design in an Academic Environment, Royal Irish Academy.
- Purcell, P., M. Long, H. Scully, and T. Gleeson. 2001. Seepage from landfill sites and animal waste storage tanks. Proc. 3rd British Geotechnical Association Conference on Geoenvironmental impact management, (Eds. R.N. Yong and H.R. Thomas), Edinburgh, Scotland, 477-482. Thomas Telford Publishing.
- Scully, H.A., T.N. Gleeson, and E.G. O'Riordan. 2002. An evaluation of earth bank tanks for slurry storage. Poster, Abstract and Presentation. Agricultural Research Forum, Teagasc, Tullamore, Ireland.
- Purcell, P., H. Scully, and T. Gleeson. 2002. Flow characteristics of natural soil liners for the containment of landfill leachate and agricultural slurries. Celtic Water in a European Framework ~ pointing the way towards quality, 3rd Inter-Celtic Colloquium on Hydrology and Management of Water Resources, NUI Galway, Ireland.
- Scully, H.A., E.G. O'Riordan, T. Gleeson, and P.J. Purcell. 2003. Preliminary results of a pilot-scale earth-banked tank study. Poster. Agricultural Research Forum, Teagasc, Tullamore, Ireland.
- Scully, H., T. Gleeson, P.J. Purcell, E.G. O'Riordan, and M. Long. 2004. PRB aspects of soil-lined earth banked cattle slurry stores. Abstract and Poster. 1st Intl. Symposium on Permeable Reactive Barriers, Belfast, Northern Ireland.
- Scully, H.A. 2004. An evaluation of earth-banked tanks for slurry storage. Presentation, International Association of Hydrogeologists (IAH) Technical Discussion Meeting ~ Groundwater and Agricultural Activities, Geological Survey of Ireland (GSI), Dublin.
- Scully, H.A., P.J. Purcell, and T.N. Gleeson. 2004. Earth-banked tanks for the winter storage of animal slurry. Journal of the Chartered Institution of Water and Environmental Management (CIWEM), 18, 3, 146-149.
- Purcell, P.J., and H. Scully. 2005. Modelling the flow of animal slurry through soil liners. 1st International Conference on Environmental Science and Technology, New Orleans.

AFTERWORD

The results of this research was presented to various regulatory and academic bodies and interested parties via publications in peer-reviewed journals, presentations of papers at conferences and symposia, Teagasc open days, in-service training of advisors, popular media sources etc. Interest generated in the research was very encouraging and, coupled with concurrent research findings in other novel farming systems, an inter-agency technical working group was established to examine various 'low cost farming options' including earth-banked tanks, and, if deemed suitable by the group, to develop specifications and technical guidance for same. In October 2005, the technical working group signed off on a version of a specification and guidance document for earth-banked tanks (re-christened earth-lined stores).

Since March 2006, earth-lined stores are approved structures for the storage of slurry and effluent by the Department of Agriculture and Food. The approved specification and guidance document is available for download on the Department of Agriculture and Food's website: www.agriculture.gov.ie under the 'Farm Buildings' section. The specification is entitled "Minimum Specification for Earth-Lined Slurry/Effluent Stores and Ancillary Works" and the guidance document is entitled "Guidance Document for the Design, Siting and Operation of Earth-Lined Slurry/Effluent Stores".