

Dereplication of *Streptomyces* sp. AMC 23 polyether ionophore antibiotics by accurate-mass electrospray tandem mass spectrometry

Eduardo J. Crevelin,^a Antônio E. M. Crotti,^a Tiago D. Zucchi,^b Itamar S. Melo^b and Luiz A. B. Moraes^{a*}



Actinomycetes, especially those belonging to the genus *Streptomyces*, are economically important from a biotechnological standpoint: they produce antibiotics, anticancer compounds and a variety of bioactive substances that are potentially applicable in the agrochemical and pharmaceutical industries. This paper combined accurate-mass electrospray tandem mass spectrometry in the full scan and product ion scan modes with compounds library data to identify the major compounds in the crude extract produced by *Streptomyces* sp. AMC 23; it also investigated how sodiated nonactin ($[M + Na]^+$) fragmented. Most product ions resulted from elimination of 184 mass units due to consecutive McLafferty-type rearrangements. The data allowed identification of four macrotetrolides homologous to nonactin (monactin, isodinactin, isotrinactin/trinactin and tetranactin) as well as three related linear dimer compounds (nonactyl nonactate, nonactyl homononactate and homononactyl homononactate). The major product ions of the sodiated molecules of these compounds also originated from elimination of 184 and 198 mass units. UPLC-MS/MS in the neutral loss scan mode helped to identify these compounds on the basis of the elimination of 184 and 198 mass units. This method aided monitoring of the relative production of these compounds for 32 days and revealed that the biosynthetic process began with increased production of linear dimers as compared with macrotetrolides. These data could facilitate dereplication and identification of these compounds in other microbial crude extracts. Copyright © 2014 John Wiley & Sons, Ltd.

Additional supporting information may be found in the online version of this article at the publisher's web site.

Keywords: macrotetrolides; actinomycetes; fragmentation; UPLC-MS/MS; nonactin acid

Introduction

Actinomycetes produce about 10 000 bioactive compounds from microbial sources; such compounds are interesting for the agrochemical and pharmaceutical industries.^[1] Actinomycetes consist of Gram-positive bacteria with high guanine and cytosine content.^[2] They act as a key biocontrol agent in the management of many phytopathogenic fungi.^[3] Moreover, these microorganisms, especially those belonging to the genus *Streptomyces*, are economically important from the biotechnological standpoint: they produce antibiotics, anticancer compounds, melanins, enzymes, enzyme inhibitors and single cell protein; they also function as probiotics in aquaculture.^[4–6] In addition, actinomycetes can exclusively produce polyether ionophores,^[7] such as nonactin, which belongs to the class of macrotetrolides and occurs in different *Streptomyces* species.^[8–10]

Over the last two decades, researchers have employed classic and time-consuming strategies to isolate natural products from various biological matrices produced by microorganisms, marine organisms and plants; they have also used several chromatographic techniques as well as spectroscopic [infrared (IR), ultraviolet (UV), 1D and 2D nuclear magnetic resonance (NMR) and mass spectrometry (MS)] data for further elucidation of chemical structures.^[11]

Dereplication is the process that differentiates between crude extracts containing known natural products and crude extracts that possess novel metabolites of interest. This process represents an important step in drug discovery programs, because it

enables early structural determination of known secondary metabolites and helps to rationalize and optimize bioguided isolation procedures.^[12,13] As for MS, dereplication constitutes a fast and reliable strategy to screen crude extracts for the presence of known compounds before the start of isolation and purification efforts.^[14] In this scenario, dereplication has been a crucial stage in the search for novel bioactive secondary metabolites.^[15] Dereplication strategies exclusively combine chromatographic [usually high-performance liquid chromatography (HPLC) or gas chromatography (GC)] and spectroscopic (especially UV, MS or NMR) data with database (Dictionary of Natural Products, MassBank, NAPRALERT, Marinlit, and, with some restriction, SciFinder Scholar) searching.^[16]

MS has been the most suitable technique to dereplicate compounds that do not bear useful chromophore groups in their structures, e.g. macrotetrolides that *Streptomyces* species produce.

* Correspondence to: Luiz Alberto Beraldo Moraes. Laboratório de Espectrometria de Massas Aplicado a Química de Produtos Naturais, Departamento de Química, Faculdade de Filosofia, Ciências e Letras de Ribeirão Preto, Universidade de São Paulo (USP), Ribeirão Preto, SP 14040-901, Brazil. E-mail: luizmoraes@ffclrp.usp.br

^a Departamento de Química, Faculdade de Filosofia, Ciências e Letras de Ribeirão Preto, Universidade de São Paulo—USP, Ribeirão Preto, SP, Brazil

^b Laboratório de Microbiologia Ambiental, Empresa Brasileira de Pesquisas Agropecuária (Embrapa), Jaguariúna, SP, Brazil

Macrotetrolides are a class of little polar compounds that exhibit ionophoric properties; they originate from nonactin acid and homononactin acid and form a large tetralactone that can insert tetrahydrofuran moieties.^[17] Linear dimer derivatives of nonactin and homononactin acids have been isolated from a *Streptomyces globisporus* strain.^[18] These compounds exhibit a wide range of biological activities including antimicrobial, insecticidal, acaricidal (miticidal), antiprotozoan (coccidiostatic), antiparasitic (anthelmintic)^[18] and immunosuppressive actions.^[19] According to the literature, the biological activity of ionophores stems from their strong affinity for alkali metals and their ability to solubilize and transport metals across cell membranes as either undissociated acids or neutral complexes.^[20] However, ionophores such as macrotetrolides do not contain useful chromophore groups, which limits the use of HPLC-UV or high-performance liquid chromatography with a diode-array detector (HPLC-DAD) to dereplicate these compounds.^[21] High-resolution mass separation and accurate mass measurements using quadrupole time-of-flight (QTOF), Orbitrap or Fourier transform ion cyclotron resonance (FTICR) mass analyzers as well as tandem (MS/MS) and sequential (MSⁿ) techniques have furnished data concerning the molecular formulas and the fragmentation patterns of ionophores like salinomycin, monensin, lasalocid, maduramicin, narasin and semduramicin.^[22–24]

This paper reports on a simple, fast and effective MS-based dereplication method to identify macrotetrolides and some related linear dimer compounds in the crude extract produced by a *Streptomyces* sp. AMC 23 strain. This method helped to monitor production of these metabolites for a period of 32 days.

Materials and methods

Chemicals and reagents

Dextrose was used to prepare the microbial culture media. Methanol (CH₃OH, HPLC grade) was purchased from Merck (Darmstadt, Germany). Formic acid (FA) and standard nonactin sample were acquired from Sigma-Aldrich. Deionized water (Milli-Q) was used throughout the study.

Strains and culture conditions

The *Streptomyces* sp. AMC 23 strain was recovered from starch-casein agar (SCA)^[25] plate supplemented with cycloheximide and nystatin (50 µg ml⁻¹) previously inoculated with soil suspension and incubated at -28 °C for seven days. The soil sample had been collected from *Rhizophora mangle* rhizosphere in a well-preserved mangrove at Ilha do Cardoso (25°7'S 47°58'W, State of São Paulo, Brazil). The soil that adhered to the roots was diluted in sterilized saline water (0.85%). The organism was maintained on SCA plates and as a mixture of mycelial fragments and spores in 10% (v/v) glycerol at -20 °C.

Cultivation of actinomycete and sample preparation for dereplication analysis

Prior to inoculation in 300 ml of potato dextrose (PD), a pre-inoculum of *Streptomyces* sp. AMC 23 was cultured in 50 ml of PD broth at 130 rpm and 30 °C for 2 days, using a rotary shaker. The inoculum was also grown for 2 days before its transfer to 4 ml of PD and was then incubated for 7 days under the previously

described conditions. Next, the fermentation broth was centrifuged at 10 000 rpm for 10 min at 4 °C, to separate the mycelium. The crude extract was removed with ethyl acetate, followed by solvent elimination in a rotary evaporator (Büchi® Waterbath B-480) at 40 °C. The procedure afforded 210 mg of the crude extract.^[26] A CH₃OH standard stock solution of nonactin (1.0 mg ml⁻¹) was prepared before the MS analyses.

ESI-QTOF-MS analysis

A sample (1 mg) of the crude extract was dissolved in a CH₃OH/H₂O 80:20 (v/v) solution containing 0.1% FA, filtered through a Millipore filter (0.45 µm), and analyzed by electrospray ionization (ESI) mass spectrometry in the positive ion mode using a QTOF II (Micromass, Manchester, UK) mass spectrometer. The ESI interface conditions were as follows: capillary voltage = 3.0 kV, cone voltage = 40 V, source temperature = 100 °C and desolvation temperature (N₂) = 200 °C (mass range from *m/z* 150 to 1200). The sample was introduced into the mass spectrometer with the aid of a syringe pump (Harvard, Holliston, MA, USA) operating at a flow rate of 5 µl min⁻¹. Tandem mass spectrometry experiments (MS/MS) with collision-induced dissociation (CID) were conducted using argon as collision gas on the selected precursor ions ([M + Na]⁺) at collision energy values ranging from 20 to 60 eV. The mass analyzer was calibrated using a mixture of 0.1% phosphoric acid and CH₃OH 1:1 (v/v), to achieve a resolution of approximately 10 000. Accurate masses observed in all the experiments were within 1 × 10⁻³ (from 1 to 7 ppm depending on the mass) of the theoretical masses of the ions. Mass data were processed by the MassLynx V4.1 software.

UPLC-MS/MS analysis

Neutral loss scan of the crude extract produced by *Streptomyces* sp. AMC 23 strain via UPLC-MS/MS was recorded using a Waters ACQUITY UPLC *H-Class* system coupled to the Xevo® TQ-S tandem quadrupole (Waters Corporation, Milford, MA, USA) mass spectrometer with a Z-spray source operating in the positive mode. Three microliters of the sample was injected into an ACQUITY-BEH C₁₈ column (2.1 × 50 mm, 1.7 µm) from Waters; the mobile phase used for gradient elution consisted of H₂O as system A and CH₃OH (0.1% FA) as system B. The flow rate was 0.3 ml min⁻¹. The gradient elution program started with 30% B, raised B to 100% in the following 20 min, remained at 100% B for 5 min, and returned to the initial condition (30% B) within the following 5 min. Neutral loss scans were recorded between 300 and 900 mass units; the system was operated in the positive ion mode. The source and operating parameters were optimized as: capillary voltage = 3.2 kV, cone voltage = 40 V, source offset = 60 V, Z-spray source temperature = 150 °C, desolvation temperature (N₂) = 350 °C, desolvation gas flow = 500 l h⁻¹, collision gas flow = 0.15 ml min⁻¹ and collision energies = 32 eV (neutral loss of 198 mass units) and 34 eV (neutral loss of 184 mass units) for UPLC-MS/MS analysis.

Compounds monitoring during strain development

The AMC 23 species was grown in 50 ml of PD broth under constant agitation (130 rpm) at 30 °C for 32 days. The relative production of the compounds was evaluated by sampling 1 ml aliquots of the culture medium at 0, 3, 4, 5, 6, 7, 10, 11, 12, 13, 14, 15, 17, 19, 21, 26, 29 and 32 days. The aqueous phase of each

aliquot was submitted to liquid–liquid extraction in microtubes using ethyl acetate. Then, the aqueous portion was discarded, and the organic phase (ethyl acetate) was evaporated to dryness in a centrifugal evaporator (Speed Vac, Univapo 100 ECH®). The resulting crude extracts were re-suspended in 1 ml of CH₃OH and analyzed by mass spectrometry in the selective ion monitoring (SIM) mode employing UPLC-MS. The ions of *m/z* 409, 423, 437, 773, 787, 801 and 815 were selected for this experiment. The compounds production curves were built by relating the area intensity ratio with the culture period.

Results and discussion

ESI-MS/MS of nonactin (1)

Investigation of the fragmentation profile of nonactin (**1**, Fig. 1), a macrotetrolide identified in many crude extracts of *Streptomyces* species, helped to identify possible diagnostic ions of macrotetrolides.^[10,27–29] The peak corresponding to the protonated nonactin ([M+H]⁺) of *m/z* 737 did not appear even after FA addition, as described for other ionophores.^[30] Peaks corresponding to the nonactin cationized with sodium ([M+Na]⁺, *m/z* 759), ammonium ([M+NH₄]⁺, *m/z* 754) and potassium ([M+K]⁺, *m/z* 775) were observed in the full scan MS spectrum (data not shown). According to the literature, four oxygen atoms from the tetrahydrofuran rings and four carbonyl oxygen atoms surround the metal ion in macrotetrolides, whereas the methyl and other R substituents and the methylene groups of the tetrahydrofuran rings lie on the outside.^[31] Because it had the highest relative intensity in the full scan MS spectrum, the sodiated nonactin ([M+Na]⁺, *m/z* 759) served as precursor ion in MS/MS experiments employing collision energy values ranging from 20 to 60 eV (with step up to 10 eV each time). Collision energy of 50 eV was the optimal value to record the product ion mass spectrum of the compound of *m/z* 759, in which the number of

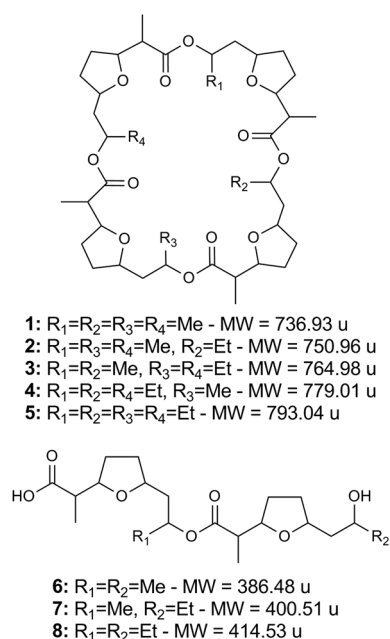

Figure 1. Chemical structures of nonactin (**1**), its homologous macrotetrolides **2–5**, and the linear dimer derivatives of nonactin and homononactin acids (**6–8**).

product ions with relative intensity higher than 5% was maximum (Fig. 2). Figure 3a depicts the product ion mass spectrum of nonactin obtained at collision energy of 50 eV.

Table 1 lists the main product ions from sodiated nonactin (*m/z* 759, [1+Na]⁺) and their relative intensities for the product ion mass spectrum acquired at 50 eV. Product ions displaying relative intensity higher than 5% were included here. At 50 eV, the ions of *m/z* 575, 391 and 207 were the main product ions from sodiated nonactin. Accurate-mass measurements revealed that these fragments derived from losses of one, two and three C₁₀H₁₆O₃ (184 mass units) molecules from the precursor ion ([M+Na]⁺), respectively, via consecutive McLafferty-type rearrangements (Scheme 1).^[32] These reactions had been previously described for other polyether ionophores, such as lasalocid^[24] and tetronasin.^[20] In principle, the first McLafferty-type rearrangement results in opening of the tetralactonic ring of nonactin, to give an undissociated carboxyl group, which could involve any carbonyl oxygen. Here, we referred to the retro-ene reaction as 'McLafferty-type rearrangement', because the lone pair of the carbonyl oxygen abstracts the γ -hydrogen, which also occurs in the classic McLafferty rearrangement in aliphatic ketones and their analogs, to culminate in multiple bond cleavage under electron ionization (EI-MS) conditions.^[33] However, McLafferty rearrangements are typical of odd-electron ions (OE⁺) and violate the Odd-Electron Rule, whereas the McLafferty-type rearrangement involves even-electron ions (EE⁺), such as protonated ([M+H]⁺) and sodiated molecules ([M+Na]⁺), which obey the Even-Electron Rule.^[34] The McLafferty-type rearrangement has been also observed for complexes formed between alkali metal acceptor ions and Lewis bases containing carbonyl functions such as formaldehyde complexes bearing Na and Li.^[35] According to the literature, the $n \rightarrow \pi^*$ transition believed to be involved in McLafferty-type hydrogen rearrangement processes is energetically favorable.^[35] Hence, we decided to use R₁, R₂, R₃ and R₄ to distinguish between the four methyl groups in the nonactin structure, which consequently helped to identify the different fragmentations processes that could generate the main product ions of its sodiated molecule (*m/z* 759). Assuming that the first McLafferty-type rearrangements culminated in cleavage of the C–O bond of the nonactin acid residues containing R₂ and R₃ (Scheme 1), it was possible to compare the nonactin

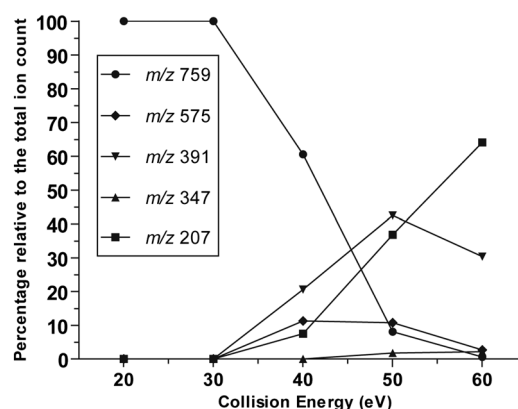

Figure 2. Percentages of the product ions of sodiated nonactin (*m/z* 759) relative to the total ion count versus collision energy on the ESI-QTOF equipment. Argon was used as the collision gas.

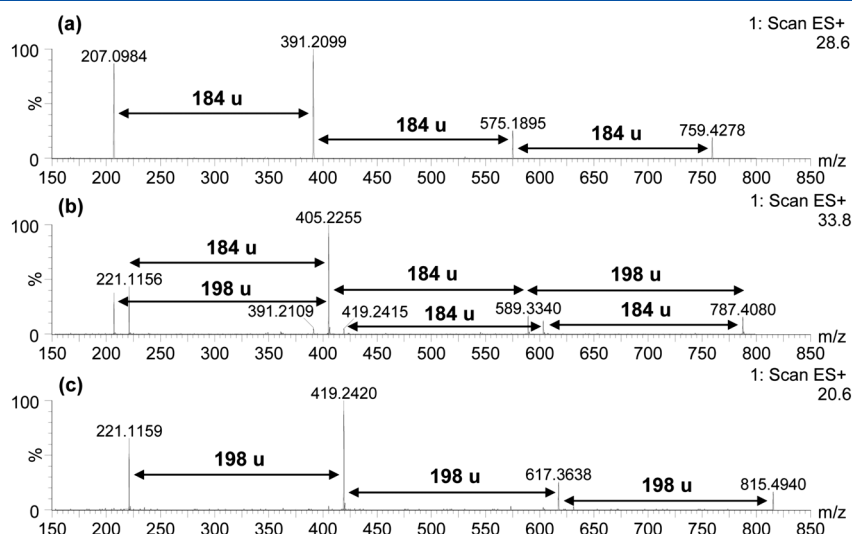

Figure 3. Product ion mass spectra of sodiated compounds **1** (a, m/z 759), **3** (b, m/z 787) and **5** (c, m/z 815).

fragmentation profile with those of homologous macrotretrolides. In this way, the product ion of m/z 575 could originate from $C_9H_{14}O_3R_3$ or $C_9H_{14}O_3R_2$ eliminations following pathways I and II, respectively. Further elimination of 184 mass units from **B** (loss of $C_9H_{14}O_3R_2$ or $C_9H_{14}O_3R_4$ molecules) and **C** (loss of $C_9H_{14}O_3R_3$ or $C_9H_{14}O_3R_1$ molecules) should yield the isobaric ions **D**, **E** and **F**. Thus, the product ion of m/z 391, which is the base peak in the MS/MS spectrum of sodiated nonactin, could result from three different pathways. Similarly, loss of 184 mass units from **D** (elimination of $C_9H_{14}O_3R_2$ or $C_9H_{14}O_3R_1$), **E** (elimination of $C_9H_{14}O_3R_1$ or $C_9H_{14}O_3R_4$) or **F** (elimination of $C_9H_{14}O_3R_3$ or $C_9H_{14}O_3R_4$) should afford the isobaric ions **G**, **H**, **I** and **J** (m/z 207). In this paper, we will use the fragmentation pathways followed by nonactin to distinguish between the sequence of groups R_1 , R_2 , R_3 and R_4 in other homologous macrotretrolides.

ESI-TOF-MS/MS analysis of the dereplication of macrotretrolide ionophores and linear dimers of nonactin and homononactin acids in the crude extract produced by *Streptomyces* sp. AMC 23

ESI-QTOF-MS in the full scan mode helped to investigate dereplication of nonactin and other macrotretrolides in the crude extract produced by *Streptomyces* sp. AMC 23. The mass spectrum (Fig. 4) displayed two major groups of peaks, from m/z 750 to 850 and from m/z 350 to 450. The first group of peaks had high relative intensity, and the difference between the peaks was equal to 14 mass units. This difference indicated the presence of homologous compounds belonging to the same class of chemical compounds. Peaks that differed by 5 and 16 mass units from each other also emerged, which might be due to the mass differences between the ions $[M + NH_4]^+$ and $[M + Na]^+$ and the ions $[M + Na]^+$ and $[M + K]^+$, respectively. Similarly, group of peaks of m/z between 350 and 450 also differed by 14 and 16 mass units from each other. Together, these data suggested the existence of compounds with ionophoric character, which have high chemical affinity for metal cations and commonly originated due to action of *Streptomyces* species.

Next, the mass units relative to NH_4^+ , Na^+ and K^+ were subtracted from the group of peaks of m/z between 750 and

850. Then, to search for possible chemical structures, the resulting mass values and the chemotaxonomic information of the microorganism were entered in the updated Dictionary of Natural Products (DNP, online version). These input data resulted in a hit list of potential structures, with emphasis on a series of macrotretrolides homologous to nonactin. Tandem mass spectrometry was carried out with the sodiated molecules ($[M + Na]^+$) of these compounds as precursor ions using argon as the collision gas at 50 eV. Table 1 shows the major product ions; product ions with relative intensity higher than 5% are discussed here.

The product ion mass spectrum of the compound of m/z 773 $[2 + Na]^+$ revealed peaks corresponding to product ions originating from consecutive eliminations of 184 and 198 mass units (Supplementary Fig. S1a, see Supplementary Material). As discussed for nonactin, the former referred to elimination of a $C_{10}H_{16}O_3$ molecule, suggesting that this compound consisted of a macrotretrolide ionophore. On the other hand, elimination of 198 mass units ($C_{11}H_{18}O_3$) from $[2 + Na]^+$ and the difference of 14 mass units as compared with the sodiated nonactin indicated that an ethyl group existed in the structure. In combination with the presence of the fragment ions of m/z 207 ($R = Me$) and m/z 221 ($R = Et$), the data evidenced that compound **2** was the macrotretrolide monactin, also identified in extracts produced by *Streptomyces*.^[36,37]

As for compound **3** (Fig. 3b), the product ions from $[3 + Na]^+$ (m/z 787) displayed mass difference of 28 mass units as compared with the peaks of the product ions from sodiated nonactin (m/z 759), which pointed to the presence of two additional ethyl groups or one isopropyl group. However, the main fragment ions of the product ion mass spectrum of sodiated **3** (m/z 787) resulted from eliminations of 184 ($C_{10}H_{16}O_3$) or 198 ($C_{11}H_{18}O_3$) mass units (Table 1). These data indicated the presence of two ethyl and two methyl groups in the structure and excluded the existence of an isopropyl group, which would imply elimination of 212 mass units. According to the literature, both dinactin and its regioisomer isodinactin are nonactin homologs bearing two ethyl groups in their structures. A detailed analysis of the fragmentation routes that led to the sequential eliminations of 184 and 198 mass units helped to

Table 1. ESI-QTOF-MS/MS data of macrotetrolides and linear dimers of nonactic and homononactic acid types identified in the crude extract produced by *Streptomyces* sp. AMC 23 (collision energy = 50 eV)

Observed $m/z^{a,b}$	Calculated m/z	Error (ppm)	Formula of the ion	Assignment
1				
759.4278 (22)	759.4290	-1.6	$C_{40}H_{64}NaO_{12}^+$	A ($[M + Na]^+$)
575.1895 (30)	575.1910	-2.6	$C_{30}H_{48}NaO_9^+$	B or C (A - $C_{10}H_{16}O_3$)
391.2099 (100)	391.2091	+2.0	$C_{20}H_{32}NaO_6^+$	D (B - $C_{10}H_{16}O_3$), E (B or C - $C_{10}H_{16}O_3$) or F (C - $C_{10}H_{16}O_3$)
207.0984 (85)	207.0992	-3.9	$C_{10}H_{16}NaO_3^+$	G (D - $C_{10}H_{16}O_3$), H (D or E - $C_{10}H_{16}O_3$), I (E or F - $C_{10}H_{16}O_3$) or J (F - $C_{10}H_{16}O_3$)
2				
773.4468 (36)	773.4446	+2.8	$C_{41}H_{66}NaO_{12}^+$	A ($[M + Na]^+$)
589.3354 (33)	589.3347	+1.2	$C_{31}H_{50}NaO_9^+$	B (A - $C_{10}H_{16}O_3$)
575.3179 (23)	575.3191	-2.1	$C_{30}H_{48}NaO_9^+$	C (A - $C_{11}H_{18}O_3$)
405.2261 (75)	405.2248	+3.2	$C_{21}H_{34}NaO_6^+$	D (B - $C_{10}H_{16}O_3$)
391.2104 (100)	391.2091	+3.3	$C_{20}H_{32}NaO_6^+$	E (B - $C_{11}H_{18}O_3$ or C - $C_{10}H_{16}O_3$) or F (C - $C_{10}H_{16}O_3$)
221.1151 (35)	221.1148	+1.4	$C_{11}H_{18}NaO_3^+$	G (D - $C_{10}H_{16}O_3$)
207.0988 (86)	207.0992	-1.9	$C_{10}H_{16}NaO_3^+$	H (D - $C_{11}H_{18}O_3$ or E - $C_{10}H_{16}O_3$), I (E or F - $C_{10}H_{16}O_3$) or J (F - $C_{10}H_{16}O_3$)
3				
787.4080 (15)	787.4063	+2.2	$C_{42}H_{68}NaO_{12}^+$	A ($[M + Na]^+$)
603.3518 (12)	603.3504	+2.3	$C_{32}H_{52}NaO_9^+$	C (A - $C_{10}H_{16}O_3$)
589.3340 (17)	589.3347	-1.2	$C_{31}H_{50}NaO_9^+$	B (A - $C_{11}H_{18}O_3$)
419.2415 (8)	419.2404	+2.6	$C_{22}H_{36}NaO_6^+$	F (C - $C_{10}H_{16}O_3$)
405.2255 (100)	405.2248	+1.7	$C_{21}H_{34}NaO_6^+$	E (B - $C_{10}H_{16}O_3$ or C - $C_{11}H_{18}O_3$)
221.1156 (44)	221.1148	+3.6	$C_{11}H_{18}NaO_3^+$	I (E - $C_{10}H_{16}O_3$ or F - $C_{11}H_{18}O_3$)
207.1005 (39)	207.0992	+6.3	$C_{10}H_{16}NaO_3^+$	G (D - $C_{10}H_{16}O_3$), H (D - $C_{10}H_{16}O_3$ or E - $C_{11}H_{18}O_3$) or J (F - $C_{11}H_{18}O_3$)
4				
801.4790 (28)	801.4759	+3.9	$C_{43}H_{70}NaO_{12}^+$	A ($[M + Na]^+$)
617.3644 (11)	617.3660	-2.6	$C_{33}H_{54}NaO_9^+$	B (A - $C_{10}H_{16}O_3$)
603.3517 (40)	603.3504	+2.1	$C_{32}H_{52}NaO_9^+$	C (A - $C_{11}H_{18}O_3$)
419.2424 (83)	419.2404	+4.8	$C_{22}H_{36}NaO_6^+$	D (B - $C_{11}H_{18}O_3$) or E (B - $C_{11}H_{18}O_3$ or C - $C_{10}H_{16}O_3$)
405.2237 (100)	405.2248	-2.7	$C_{21}H_{34}NaO_6^+$	F (C - $C_{11}H_{18}O_3$)
221.1162 (97)	221.1148	+6.3	$C_{11}H_{18}NaO_3^+$	G (D - $C_{11}H_{18}O_3$), H (D - $C_{11}H_{18}O_3$ or E - $C_{11}H_{18}O_3$) or J (F - $C_{11}H_{18}O_3$)
207.1003 (37)	207.0992	+5.4	$C_{10}H_{16}NaO_3^+$	I (E - $C_{11}H_{18}O_3$ or F - $C_{10}H_{16}O_3$)
5				
815.4940 (16)	815.4916	+2.9	$C_{44}H_{72}NaO_{12}^+$	A ($[M + Na]^+$)
617.3638 (25)	617.3660	-3.6	$C_{33}H_{54}NaO_9^+$	B or C (A - $C_{11}H_{18}O_3$)
419.2420 (100)	419.2404	+3.8	$C_{22}H_{36}NaO_6^+$	D (B - $C_{11}H_{18}O_3$), E (B or C - $C_{11}H_{18}O_3$) or F (C - $C_{11}H_{18}O_3$)
221.1159 (67)	221.1148	+5.2	$C_{11}H_{18}NaO_3^+$	G (D - $C_{11}H_{18}O_3$), H (D or E - $C_{11}H_{18}O_3$), I (E or F - $C_{11}H_{18}O_3$) or J (F - $C_{11}H_{18}O_3$)
6				
409.2206 (100)	409.2197	+2.2	$C_{20}H_{34}NaO_7^+$	A ($[M + Na]^+$)
225.1105 (72)	225.1097	+3.7	$C_{10}H_{18}NaO_4^+$	K or M (A - $C_{10}H_{16}O_3$)
207.1003 (10)	207.0992	+5.5	$C_{10}H_{16}NaO_3^+$	L (A - $C_{10}H_{18}O_4$) or N (M - H_2O)
7				
423.2361 (7)	423.2353	+1.8	$C_{21}H_{36}NaO_7^+$	A ($[M + Na]^+$)
239.1260 (100)	239.1254	+2.5	$C_{11}H_{20}NaO_4^+$	K (A - $C_{10}H_{16}O_3$)
225.1090 (10)	225.1097	-3.3	$C_{10}H_{18}NaO_4^+$	M (A - $C_{11}H_{18}O_3$)
207.1005 (9)	207.0992	+6.2	$C_{10}H_{16}NaO_3^+$	L (A - $C_{11}H_{20}O_4$) or N (M - H_2O)
8				
437.2525 (45)	437.2510	+3.5	$C_{22}H_{38}NaO_7^+$	A ($[M + Na]^+$)
239.1264 (100)	239.1254	+4.1	$C_{11}H_{20}NaO_4^+$	K or M (A - $C_{11}H_{18}O_3$)
221.1142 (13)	221.1148	-2.7	$C_{11}H_{18}NaO_3^+$	L (A - $C_{11}H_{20}O_4$) or N (M - H_2O)

^aRelative intensities are provided in parentheses.^bOnly ions with relative intensities higher than 5% are reported.

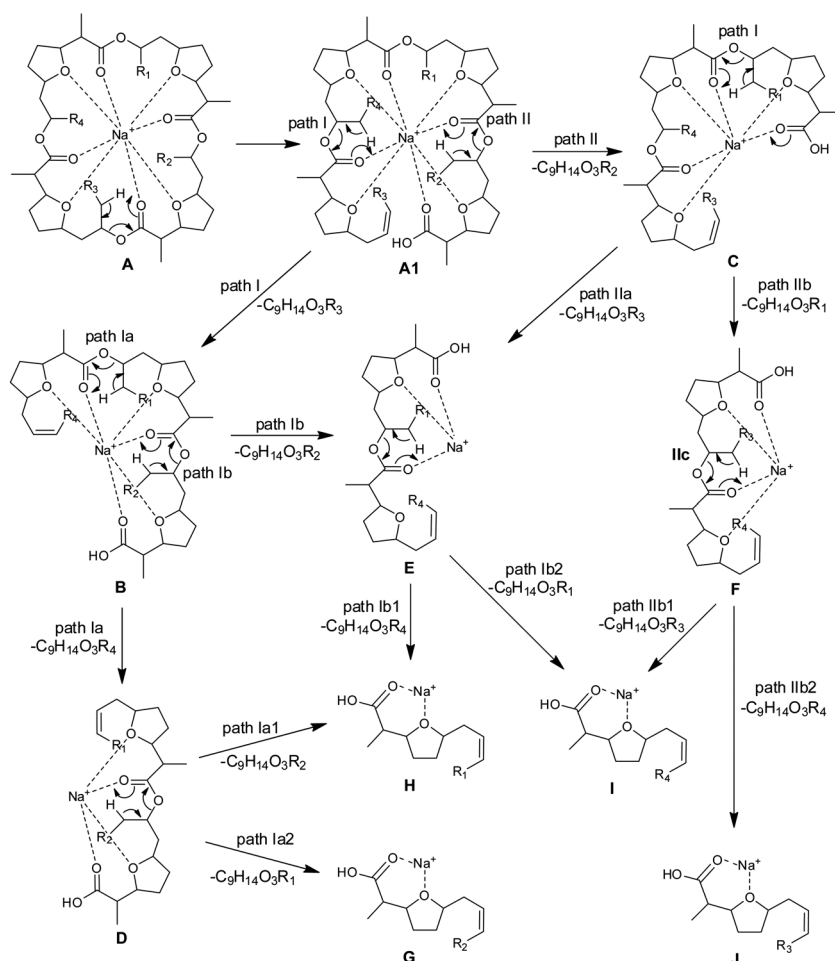

Scheme 1. Fragmentation pathways proposed for the sodiated macrotetrolides **1–5**.

differentiate between these two compounds on the basis of MS/MS data. The product ions **B** (m/z 589) and **C** (m/z 603), originating directly from the sodiated molecule by elimination of 198 and 184 mass units, respectively, suggested that opening of the macrotetrolide ring involved a carbonyl adjacent to nonactic acid moieties containing an ethyl and a methyl group, respectively. Further elimination of 184 mass units from **C** furnished the product ion **F** (m/z 419), indicating the presence of two adjacent nonactic acid moieties with methyl groups in their structures. Similarly, further elimination of 198 mass units from **B** led to **D** (m/z 391). These data were consistent with the structure of isodinactin (**3**, Fig. 1). In the case of dinactin ($R_1 = R_3 = \text{Me}$, $R_2 = R_4 = \text{Et}$), the corresponding product ions **D** and **F** should have m/z 405, whereas the product ions of m/z 419 and 391 should not arise from any fragmentation routes depicted in Scheme 1.

The sodiated compound **4** (m/z 801) was 42 mass units higher than the corresponding sodiated nonactin (m/z 759). The main product ions observed in the product ion mass spectrum of the precursor ion $[4 + \text{Na}]^+$ resulted from eliminations of 184 ($\text{C}_{10}\text{H}_{16}\text{O}_3$) and 198 units ($\text{C}_{11}\text{H}_{18}\text{O}_3$), thus excluding the presence of an isopropyl group in its structure (Supplementary Fig. S1b, see Supplementary Material). Considering that elimination of 184 mass units would require a nonactic acid moiety bearing at least one methyl group, three ethyl groups should exist at the other R positions. These data indicated that

compound **4** might be one of the diastereoisomers trinactin and isotrinactin. However, MS/MS data did not allow us to differentiate between these compounds. Finally, sodiated compound **5** (m/z 815) was 56 mass units higher than the corresponding sodiated nonactin (m/z 759). According to Table 1 and Fig. 3c, all the main product ions resulted from consecutive eliminations of 198 mass units from $[4 + \text{Na}]^+$, thereby excluding the presence of methyl or isopropyl groups in the R positions. The product ions of m/z 221 (**G**, **H**, **I** and **J**) and the absence of an ion of m/z 207 corroborated with the presence of four ethyl groups in the homononactic acid moieties, showing that compound **4** was tetranactin. Literature studies have also identified trinactin, isotrinactin and tetranactin in crude extracts produced by *Streptomyces* species.^[36,37]

The same strategy employed for macrotetrolides (e.g. subtracting the mass units relative to NH_4^+ , Na^+ and K^+ and entering the resulting molecular formula and chemotaxonomic information of the microorganism in the updated DNP to search for possible chemical structures) helped to identify the minor compounds detected in the low mass range (from m/z 350 to 450). These input data resulted in a homologous series of linear dimers of nonactic and homononactic acids. Next, we used the corresponding sodiated molecule of compounds **6**, **7** and **8** (m/z 409, 423 and 437, respectively) as precursor ions in product ion experiments that employed argon at a collision energy of 50 eV (Fig. 5a–c). Table 1 contains the major product ions of these

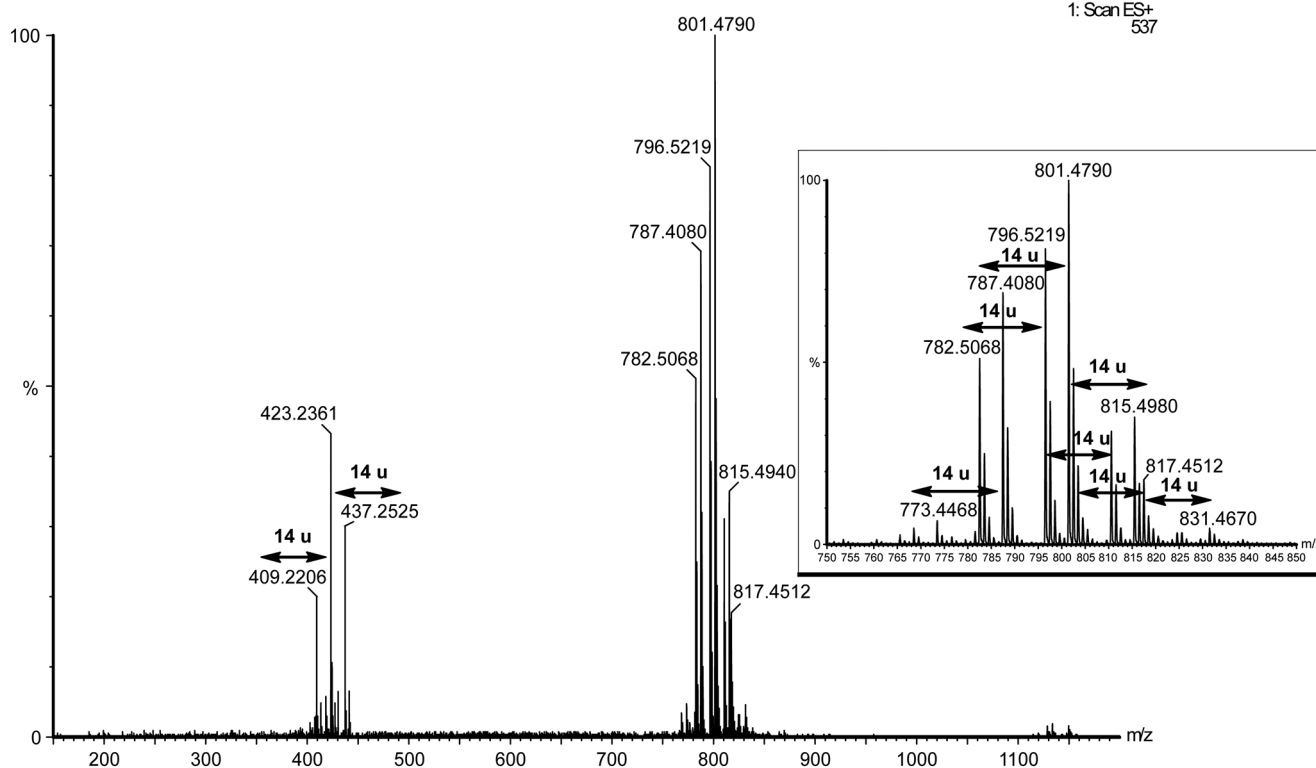

Figure 4. Full scan mass spectrum of the crude extract obtained from *Streptomyces* sp. AMC 23.

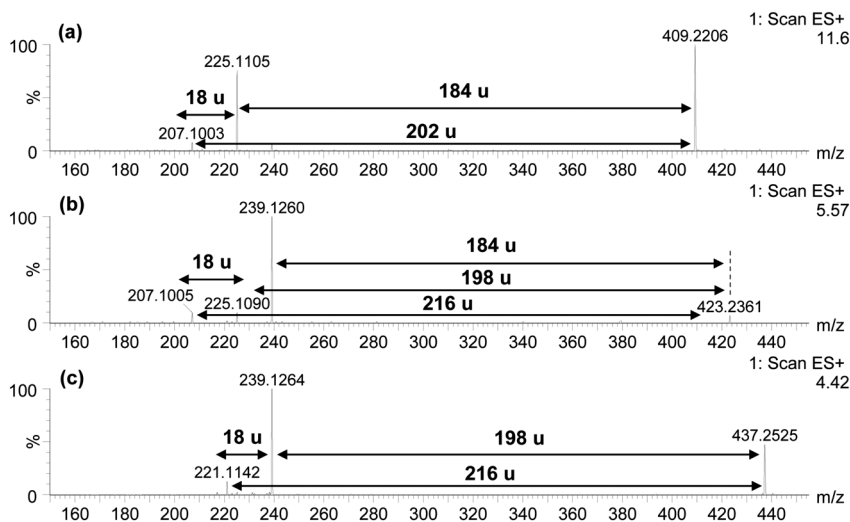
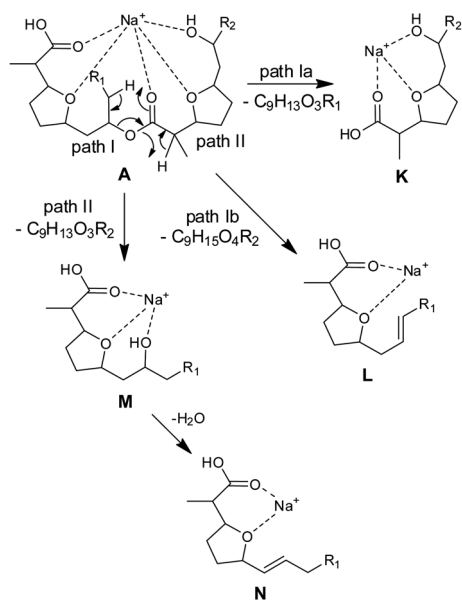

Figure 5. Product ion mass spectra of sodiated **6** (a, m/z 409), **7** (b, m/z 423) and **8** (c, m/z 437).

compounds. Similarly to macrotetrolides, elimination of 184 mass units (for **6** and **7**) and 198 mass units (for **7** and **8**) from the precursor ion ($[M + Na]^+$) took place. In addition, two main product ions of m/z 225 (for **1** and **2**) and m/z 239 (for **2** and **3**) that differed by 14 mass units evidenced structural moieties with an ethyl or methyl substituent. Together, the data helped to identify nonactyl nonactate ($[6 + Na]^+$ of m/z 409), nonactyl homononactate ($[7 + Na]^+$ of m/z 423) and homononactyl homononactate ($[8 + Na]^+$ of m/z 437) (Fig. 1). LC-MS data

using APCI as ionization source had already aided identification of these linear dimer derivatives in crude extracts produced by *S. globisporus*.^[18] Elimination of 184 and 198 mass units from the precursor ion ($[M + Na]^+$) should result from McLafferty-type rearrangements similar to those proposed for macrotetrolides **1–5** (Scheme 2). On the other hand, only **6–8** gave the product ions **M** ($A-C_9H_{13}O_3R_1$) and **N** ($M-H_2O$), which stemmed from abstraction of the α -carbonyl hydrogen by the heteroatom oxygen of the ester following a four-centered transition state



Scheme 2. Fragmentation pathways proposed for the linear dimer derivatives of nonactic and homononactic acids (**6–8**).

with consequent ketene elimination ($C_9H_{13}O_3R_1$) and further water elimination.

Finally, analysis of the crude extracts produced by *Streptomyces* sp. AMC 23 using UPLC-MS/MS in the neutral loss scan mode (Fig. 6 and Fig. S2a-b, see Supplementary Material) helped to identify seven different compounds after the scan of neutral losses of 184 ($C_{10}H_{16}O_3$) and 198 ($C_{11}H_{18}O_3$) mass units in the positive ion mode. The linear dimers of the nonactic and

homononactic acid types eluted at retention times ranging from 10 to 12 min; macrotetrolides, which are less polar compounds, eluted at retention times between 18 and 20 min. The neutral loss scans of 184 and 198 mass units were sensitive enough to detect these compounds efficiently; therefore, this analytical methodology could specifically detect this class of metabolites in dereplication studies of microbial natural products.

UPLC-MS monitoring of the relative production of compounds 2–8

Streptomyces sp. AMC 23 strain growth and monitoring in PD medium for 32 days helped to assess production of the target compounds. Maximum production of **6** occurred at day seven; 17 days of cultivation was necessary to achieve maximum production of **7** and **8** (Supplementary Fig. S3, see Supplementary Material). With regard to macrotetrolides, considerable production of these compounds started at day 10, with maximum production of **2** and **4** at day 26. On the other hand, maximum production of **3** and **5** took place at day 29 (Supplementary Fig. S4, see Supplementary Material). Hence, early production of linear dimers of the nonactic and homononactic acid type in relation to macrotetrolides may be associated with consumption of these compounds, to subsequently form the tetralactones during the biosynthetic process. Indeed, a literature study reported that compound **6** could originate from the biosynthesis of **1** or even from a biosynthetic intermediate.^[38] Statistical analysis of the data showed a relative standard deviation (RSD) between 5 and 10% for all the monitored compounds. Furthermore, on the days when the production of the compounds was higher, the RSD was around 5 to 7% (Supplementary Table S1 and S2, see Supplementary Material).

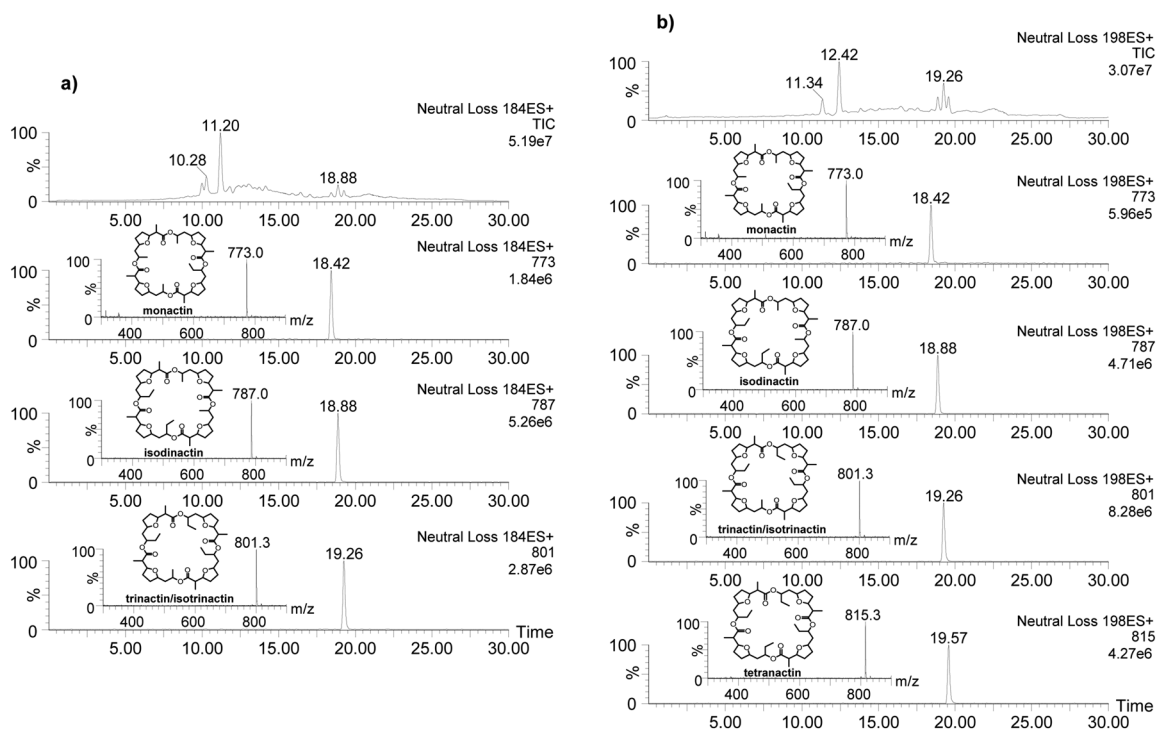

Figure 6. (a) Chromatograms of neutral loss (TIC) and extracted neutral loss of 184 u. (b) Chromatograms of neutral loss and extracted neutral loss of 198 u. Chromatograms show the mass spectra of macrotetrolides sodium adducts of m/z 773 (monactin), 787 (isodinactin), 801 (trinactin/isotrinactin) and 815 (tetranactin).

Conclusions

The use of accurate-mass electrospray tandem mass spectrometry allowed identification of three known linear dimers of the nonactic and homononactic acid type and four cyclic tetralactones (monactin, isodinactin, trinactin/isotrinactin and tetranactin) in the crude extract produced by the *Streptomyces* sp. AMC 23 strain derived from *R. mangle* rhizosphere. By combining the full scan mode, the search for structures in DNP, chemotaxonomic data and MS/MS data, it was possible to rapidly identify compounds 2–8 directly from the crude extract. This strategy enabled analysis of macrotetrolides and linear dimers of the nonactic and homononactic acids. These compounds are difficult to detect in conventional HPLC systems, because they do not bear useful chromophores. Moreover, the neutral loss scan of 184 and 198 mass units using UPLC-ESI-MS/MS as well as the fragmentation routes proposed here were efficient for the screening and preliminary identification of these classes of compounds. Therefore, the data reported herein could be useful to dereplicate and rapidly identify these compounds in microbial crude extracts.

Acknowledgements

The authors are grateful to the Brazilian Foundations FAPESP and CAPES for providing fellowship to EJC (grant no. 08/53000-0). LABM and AEMC are also grateful to FAPESP for financial support to develop this research (grants no. 2009/51145-3 and 2013/20094-0).

References

- C. X. Chen, J. Wang, H. Guo, W. Y. Hou, N. Yang, B. Ren, M. Liu, H. Q. Dai, X. T. Liu, F. H. Song, L. X. Zhang. Three antimycobacterial metabolites identified from a marine-derived *Streptomyces* sp MS100061. *Appl. Microbiol. Biotechnol.* **2013**, *97*, 3885.
- T. Matsui, J. Tanaka, T. Namihira, N. Shinzato. Antibiotics production by an actinomycete isolated from the *Termite gut*. *J. Basic Microbiol.* **2012**, *52*, 731.
- T. D. Zucchi, L. A. B. Moraes, I. S. Melo. *Streptomyces* sp ASBV-1 reduces aflatoxin accumulation by *Aspergillus parasiticus* in peanut grains. *J. Appl. Microbiol.* **2008**, *105*, 2153.
- R. Subramani, W. Aalbersberg. Culturable rare actinomycetes: Diversity, isolation and marine natural product discovery. *Appl. Microbiol. Biotechnol.* **2013**, *97*, 9291.
- L. J. da Silva, R. G. Taketani, I. S. de Melo, M. Goodfellow, T. D. Zucchi. *Streptomyces araujoniae* sp nov.: an actinomycete isolated from a potato tuber. *Antonie Van Leeuwenhoek* **2013**, *103*, 1235.
- P. Manivasagan, J. Venkatesan, K. Sivakumar, S. K. Kim. Marine actinobacterial metabolites: Current status and future perspectives. *Microbiol. Res. (Pavia)*. **2013**, *168*, 311.
- H. Wang, N. Liu, L. J. Xi, X. Y. Rong, J. S. Ruan, Y. Huang. Genetic screening strategy for rapid access to polyether ionophore producers and products in actinomycetes. *Appl. Environ. Microbiol.* **2011**, *77*, 3433.
- J. Jizba, I. Skibova. Regulation of biosynthesis of pesticidal metabolic complexes in *Streptomyces griseus*. *Folia Microbiol. (Praha)*. **1994**, *39*, 119.
- L. P. Shopotova, Y. D. Shenin. New natural insecticide from Actinomycetaceae *Streptomyces-lipmani* - Isolation, physicochemical and biological properties, and identification. *Russ. J. Appl. Chem.* **1993**, *66*, 1074.
- J. Jizba, P. Sedmera, J. Zima, M. Beran, M. Blumauerova, N. V. Kandybin, G. V. Samoukina. Macrotetrolide antibiotics produced by *Streptomyces globisporus*. *Folia Microbiol. (Praha)*. **1991**, *36*, 437.
- J. Bitzer, B. Kopcke, M. Stadler, V. Heilwig, Y. M. Ju, S. Seip, T. Henkel. Accelerated dereplication of natural products, supported by reference libraries. *Chimia* **2007**, *61*, 332.
- J. L. Wolfender, G. Marti, E. F. Queiroz. Advances in techniques for profiling crude extracts and for the rapid identification of natural products: dereplication, quality control and metabolomics. *Curr. Org. Chem.* **2010**, *14*, 1808.
- J. Yang, Q. Liang, M. Wang, C. Jeffries, D. Smithson, Y. Tu, N. Boulos, M. R. Jacob, A. A. Shelat, Y. Wu, R. R. Ravu, R. Gilbertson, M. A. Avery, I. A. Khan, L. A. Walker, R. K. Guy, X. C. Li. UPLC-MS-ELSD-PDA as a powerful dereplication tool to facilitate compound identification from small-molecule natural product libraries. *J. Nat. Prod.* **2014**. DOI: 10.1021/np4009706
- T. El-Elimat, M. Figueroa, B. M. Ehrmman, N. B. Cech, C. J. Pearce, N. H. Oberlies. High-Resolution MS, MS/MS, and UV database of fungal secondary metabolites as a dereplication protocol for bioactive natural products. *J. Nat. Prod.* **2013**, *76*, 1709.
- M. M. Silva, J. Bergamasco, S. P. Lira, N. P. Lopes, E. Hajdu, S. Peixinho, R. G. S. Berlinck. Dereplication of bromotyrosine-derived metabolites by LC-PDA-MS and analysis of the chemical profile of 14 *Aplysina* sponge specimens from the Brazilian Coastline. *Aust. J. Chem.* **2010**, *63*, 886.
- K. F. Nielsen, M. Mansson, C. Rank, J. C. Frisvad, T. O. Larsen. Dereplication of microbial natural products by LC-DAD-TOFMS. *J. Nat. Prod.* **2011**, *74*, 2338.
- B. R. Kusche, J. B. Phillips, N. D. Priestley. Nonactin biosynthesis: Setting limits on what can be achieved with precursor-directed biosynthesis. *Bioorg. Med. Chem. Lett.* **2009**, *19*, 1233.
- T. Rezanaka, J. Spizek, V. Prikylova, A. Prell, V. M. Dembitsky. Five new derivatives of nonactic and homo-nonactic acids from *Streptomyces globisporus*. *Tetrahedron* **2004**, *60*, 4781.
- Y. Tanouchi, H. Shichi. Immunosuppressive and anti-proliferative effects of a macrotetrolide antibiotic, tetranactin. *Immunology* **1988**, *63*, 471.
- T. Fonseca, N. P. Lopes, P. J. Gates, J. Staunton. Fragmentation studies on tetronasin by accurate-mass electrospray tandem mass spectrometry. *J. Am. Soc. Mass Spectrom.* **2004**, *15*, 325.
- D. A. Volmer, C. M. Lock. Electrospray ionization and collision-induced dissociation of antibiotic polyether ionophores. *Rapid Commun. Mass Spectrom.* **1998**. DOI: 10.1002/(Sici)1097-0231(19980227)12:4 < 157::Aid-Rcm134 > 3.0.Co;2-M. *12*, 157.
- B. F. Spisso, R. G. Ferreira, M. U. Pereira, M. A. Monteiro, T. A. Cruz, R. P. da Costa, A. M. B. Lima, A. W. da Nobrega. Simultaneous determination of polyether ionophores, macrolides and lincosamides in hen eggs by liquid chromatography-electrospray ionization tandem mass spectrometry using a simple solvent extraction. *Anal. Chim. Acta* **2010**, *682*, 82.
- X. S. Miao, R. E. March, C. D. Metcalfe. Fragmentation study of salinomycin and monensin A antibiotics using electrospray quadrupole time-of-flight mass spectrometry. *Rapid Commun. Mass Spectrom.* **2003**, *17*, 149.
- N. P. Lopes, P. J. Gates, J. P. G. Wilkins, J. Staunton. Fragmentation studies on lasalocid acid by accurate mass electrospray mass spectrometry. *Analyst* **2002**, *127*, 1224.
- E. Kuster, S. T. Williams. Production of hydrogen sulfide by *Streptomyces* and methods for its detection. *Appl. Microbiol.* **1964**, *12*, 46.
- E. J. Crevelin, S. P. Canova, I. S. Melo, T. D. Zucchi, R. E. da Silva, L. A. B. Moraes. Isolation and characterization of phytotoxic compounds produced by *Streptomyces* sp. AMC 23 from Red Mangrove (*Rhizophora mangle*). *Appl. Biochem. Biotechnol.* **2013**, *171*, 1602.
- Y. Tamai, K. Toume, M. A. Arai, A. Hayashida, H. Kato, Y. Shizuri, S. Tsukamoto, M. Ishibashi. Nonactin and related compounds found in a screening program for wnt signal inhibitory activity. *Heterocycles* **2012**, *84*, 1245.
- R. J. Walczak, A. J. Woo, W. R. Strohl, N. D. Priestley. Nonactin biosynthesis: the potential nonactin biosynthesis gene cluster contains type II polyketide synthase-like genes. *FEMS Microbiol. Lett.* **2000**, *183*, 171.
- L. P. Shopotova, Y. D. Shenin. New natural insecticide isolated from *Streptomyces lipmanii*. Isolation, physicochemical and biological properties and identification. *Zhurnal Prikl. Him.* **1993**, *66*, 1334.
- N. P. Lopes, C. B. Stark, H. Hong, P. J. Gates, J. Staunton. A study of the effect of pH, solvent system, cone potential and the addition of crown ethers on the formation of the monensin protonated parent ion in electrospray mass spectrometry. *Analyst* **2001**, *126*, 1630.
- B. T. Kilbourn, J. D. Dunitz, L. A. R. Pioda, W. Simon. Structure of the K⁺ complex with nonactin, a macrotetrolide antibiotic possessing highly specific K⁺ transport properties. *J. Mol. Biol.* **1967**, *30*, 559.
- G. A. Olah, T. Mathew, A. Goepfert, G. Rasul, G. K. Prakash, P. M. Esteves. Carbocationic rearrangement of pivaloyl cation and

- protonated pivalaldehyde in superacid medium: a novel solution equivalent of the McLafferty rearrangement. *J. Am. Soc. Mass Spectrom.* **2004**, *15*, 959.
- [33] J. A. Gilpin, F. W. McLafferty. Mass spectrometric analysis - aliphatic aldehydes. *Anal. Chem.* **1957**, *29*, 990.
- [34] F. P. Boer, T. W. Shannon, McLafferty F. W. Electronic structure of 6-membered cyclic transition state in some gamma-hydrogen rearrangements. *J. Am. Chem. Soc.* **1968**, *90*, 7239.
- [35] I. Vedernikova, M. Claeys, D. R. Salahub, M. E. Casida. Excitation processes in alkali-cationized esters: a molecular orbital study. *Int. J. Mass Spectrom.* **2001**, *210*, 21.
- [36] P. Jani, E. Joachim, W. Roland. Process analysis of macrotetrolide biosynthesis during fermentation by means of direct infusion LC-MS. *Biotechnol. J.* **2008**, *3*, 202.
- [37] M. Vincenti, G. Guglielmetti, N. Andriollo, G. Cassani. Structural-analysis of macrotetralide antibiotic mixtures using collision-induced dissociation mass-spectrometry. *Biomed. Environ. Mass Spectrom.* **1990**, *19*, 240.
- [38] W. F. Fleck, M. Ritzau, S. Heinze, U. Grafe. Isolation of dimeric nonactin acid from the nonactin-producing *Streptomyces spec JA 5909-1*. *J. Basic Microbiol.* **1996**, *36*, 235.

Supporting information

Additional supporting information may be found in the online version of this article at the publisher's web site.