



Sponsored by the International Bureau of the Federal Ministry of Education and Research in Germany and by the Georgian National Science Foundation

EXPLORATION AND EXPLOITATION OF GROUNDWATER AND THERMAL WATER SYSTEMS IN GEORGIA



ILIA STATE UNIVERSITY



TU Clausthal

INSTITUTE OF EARTH SCIENCES

INSTITUTE OF GEOPHYSICS

Editors
Andreas Weller
George Melikadze
Nino Kapanadze

Tbilisi, GEORGIA
2010

TABLE OF CONTENTS

1. ESTIMATION OF ZUGDIDI AND TBILISI THERMAL WATER DEPOSITS..... 5

NINO KAPANADZE, GEORGE I. MELIKADZE

Institute of Earth Sciences, Ilia State University

PAATA JANELIDZE

United Nations Development Program

2. ASSESSMENT OF THE POLLUTION PROBABILITY IN BORJOMI-BAKURIANI AREA BY APPLICATION OF HYDROCHEMICAL AND STABLE ISOTOPE METHODS13

GEORGE I. MELIKADZE

Institute of Earth Sciences, Ilia State University

3. APPLYING TEMPERATURE AND PRESSURE MEASUREMENTS FOR ESTIMATING THE SIZE OF A WATER RESERVOIR 24

GUENTER BUNTEBARTH

Institute of Geophysics, Clausthal University of Technology, Germany

GEORGE I. MELIKADZE

Institute of Earth Sciences, Ilia State University

4. PETROPHYSICAL INVESTIGATIONS ON LOWER EOCENE SANDSTONES OF TBILISI REGION	31
ANDREAS WELLER, WOLFGANG DEBSCHÜTZ, <i>Institute of Geophysics, Clausthal University of Technology, Germany</i>	
NINO KAPANADZE <i>Institute of Earth Sciences, Ilia State University, Tbilisi, Georgia</i>	
5. INVESTIGATION OF THE HEAT CONDITIONS OF TBILISI THERMAL WATER DEPOSIT.....	42
EVGENY SAKVARELIDZE <i>Institute of Earth Sciences, Ilia State University</i>	
LUDMILA GLONTI <i>Institute of Hydrogeology and Engineering Geology</i>	
6. METHODOLOGY OF CREATION OF MULTI-PARAMETRICAL NETWORK.....	50
NADEZHDA DOVGAL, GEORGE I. MELIKADZE <i>Institute of Earth Sciences, Ilia State University</i>	
7. METHODS OF HYDROGEODYNAMICAL ANALYSIS FOR REVEALING EARTHQUAKES PRECURSORS	60
GENADY KOBZEV, GEORGE I. MELIKADZE <i>Institute of Earth Sciences, Ilia State University</i>	

8. GEODYNAMICAL IMPACT ON THE WATER LEVEL VARIATIONS IN THE BOREHOLES.....69

TAMAR J. JIMSHELADZE, GENADY KOBZEV, GEORGE I. MELIKADZE

Institute of Earth Sciences Ilia State University

NATALIA ZHUKOVA

Mikheil Nodia Institute of Geophysics

9. INDUCED SEISMICITY DUE TO THE OIL PRODUCTION IN TBILISI REGION, GEORGIA.....83

TAMAZ CHELIDZE

Mikheil Nodia Institute of Geophysics

TAMAR J. JIMSHELADZE, GEORGE I. MELIKADZE

Institute of Earth Sciences, Ilia State University

10. DYNAMICS OF EARTH CRUST TILTS AND SEISMICITY AT ENGURI DAM INTERNATIONAL TEST SITE DURING DAM CONSTRUCTION AND RESERVOIR FILLING.....96

TAMAZ CHELIDZE, TEIMURAZ MACHARASHVILI, VAKHTANG ABASHIDZE, NATALIA ZHUKOVA, EKATERINE MEPHARIDZE

Mikheil Nodia Institute of Geophysics

11. CREATION OF NUMERICAL MODEL OF TBILISI GEOTHERMAL DEPOSIT110

GENADY KOBZEV, NINO KAPANADZE, GEORGE I. MELIKADZE

Institute of Earth Sciences, Ilia State University

NATALIA ZHUKOVA

Mikheil Nodia Institute of Geophysics

12. USING NUMERICAL MODELING FOR BORJOMI-BAKURIANI DRINKING WATER RESERVOIR.....124

NATALIA ZHUKOVA

Mikheil Nodia Institute of Geophysics

GEORGE I. MELIKADZE, NADEZHDA DOVGAL

Institute of Earth Sciences, Ilia State University

ESTIMATION OF ZUGDIDI AND TBILISI THERMAL WATER DEPOSITS

NINO KAPANADZE, GEORGE I. MELIKADZE

Institute of Earth Sciences, Ilia State University

PAATA JANELIDZE

United Nations Development Program

Owing to its geological location Georgia has considerable resources of natural thermal waters and has long tradition of their exploitation. Nowadays approximately 250 natural thermal springs and artificial wells are known, as well as spring clusters with water temperature of 30-108 degrees. Although the geothermal potential of the country exhibits a promising resource, currently the situation is changed for the worse at the majority of thermal water deposits in Georgia, since the irrational exploitation of thermal deposits and due to climate changes led to decrease of well pressure and debits. This paper summarizes the geothermal potential of Georgia based on existing data and outlines one of the major projects that have already implemented to assess the potential of Tbilisi geothermal field using the hydrodynamic digital modeling approach. As a result of modeling work, the 10 years perspective of thermal deposit of Tbilisi was assessed for present conditions of exploitation as well as its behavior under simulated geothermal circulation system.

Keywords: Thermal water, geothermal circulation system

Zugdidi geothermal field

Within the Zugdidi deposit, 25 wells have been drilled. These wells have produced $82^{\circ} - 102^{\circ}$ C hot water with 25000 cubic meters discharge from the depth of 1272-2820 meters, which is equal to 42500 t of conditional fuel (annual production 250000 megawatt/hour). Thermal water containing horizon is represented by Lower Cretaceous limestone complex composed of layered and massive dolomitized fractured and karstic limestone by which the Urtian Brachyantocline is build At the west end of Tsaishi village, the anticline is broken by submeridional fault, along which the two blocks are shifted by 1000 m. In the up thrown wing a low-mineralized (0.8-1.0 g/l)

Regional geography and geology

Georgia is a country of Caucasus region of Eurasia. It covers the territory of 69,700 km² and is bounded to the west by Black sea, to the East Azerbaijan, to the north Russia and to the South by Turkey and Armenia. Owing to its special location, the climate of the country varies from the subtropical conditions on the Black sea coast to the continental in the east with cold winters and dry summers. Annual precipitation reaches 1000-2000 mm on the west coastal lowlands, when it can be only 400-1600 mm during spring and autumn. The mean temperature in winter is 5° C and in summer 22° C, but the last value may increase if we take into account the very hot summers last years.

Geologically the territory of Georgia is located in the central and western parts of the Trans-Caucasus and lies between the Euro-Asiatic and Afro-Arabian plates. The geologic evolution of Georgia is controlled, to a great extent, by the development of the whole Caucasus segment of the Mediterranean belt. Three major tectonic units can be distinguished according to the geologic evolution of Georgia: 1) Fold system of the Greater Caucasus which represents a marginal sea in the geological past, 2) Trans-Caucasus inter-mountain area which marks the northern part of the Trans-Caucasus island arc, 3) Fold system of the Lesser Caucasus, the

southern part of the ancient Trans-Caucasus island arc. Closely related to the geological evolution, Georgia whose about two third of territory is occupied by mountains is characterized by rough topography. The country lies between the Greater Caucasus in the north and the Lesser Caucasus range in the south. The intermountain area is divided by the Likhi ridge into the Kolkheti (Rioni) and Lueria (Kura) lowlands. The Meskhети and Trialeti ridges together with the volcanic highlands in the south make up the major geographic units in Georgia.

Geothermal regions of Georgia

Owing to the high geothermal potential in the South Caucasus and particularly in Georgia, a confirmed total reserve of 90,000 m³/day, corresponding to a heat potential of 500,000 tons of equivalent fuel annually, have been recorded. The amount of thermal flow for the main parts of Georgia can be listed as follows: 1) The south flank of Caucasus Mountains - 100 mWm⁻²; 2) Plate of Georgia; a) for the west zone 40 mWm⁻² b) for the east zone 30mWm⁻²; 3) Adjara-Trialeti folded system a) central part 90 mWm⁻² b) the east zone 50 mWm⁻²; 4) Artvin- Bolnisi platform 60 mWm⁻². Figure 1 shows the main geothermal fields in Georgia. The reservoir formations are fractured karstic limestones of the Upper Cretaceous in the sedimentary trough and at the southeast where the reservoir formations are volcanic and sandstones of Paleocene-Middle Eocene in the fold system. The maximum heat flow is observed for the central zone of folded part of Georgia and the minimum for the plate. The heat flow for Adjara-Trialeti folded system is characterized by the middle range. The temperature condition of Paleocene- middle Eocene thermal water bearing complex is better investigated for Tbilisi region. This investigation revealed that temperature condition of this complex is influenced by depth of high thermal resistivity upper Eocene rocks as well as their thickness. From the surface of volcanic-sedimentary formation of middle Eocene the temperature of rocks increases to all direction from 20⁰ C till 100⁰ C. To the north-east the increase of temperature is less than to other directions because of nearness of the plate. On the contact of Cretaceous – Eocene temperature has remarkable variation: to the farthest west, where upper Cretaceous is raised till 500 m, we have temperature

variation from 100 till 160 °C, when to the North and East, where the Cretaceous deeps till 600 m we have temperature about 240 °C.

By the amount of observed resources, their degree of thermal potential and exploitation perspectives thermal water deposits in Tbilisi and Zugdidi are the most promising; thus the assessment of their conditions should be regarded as the most important task.

Water of 80-85 °C is flowing, while in the downthrown wing is moving low-mineralized (0.8-1.0 g/l) water of 95-102° C. Because of political and economical situation it was impossible to elucidate the character of hydrodynamic relationship between wells and shifted up thrown and downthrown blocks. So it is impossible to answer the questions about connectivity of deposit and present the total deposit report as well as its possible exploitation scheme.

Tbilisi geothermal field

Tbilisi is situated in Achara-Trialeti mountain system, which is divided by active geological faults. Part of this system represents drainage of sulphur water spa resort located in the central part of Tbilisi. The hot natural springs of spa resort are connected to the outcropping Middle Eocene sediments that occur along the Mtkvari (Kura) river valley. The recharge area is located to the west up in the mountains. Water from the natural springs has a temperature ranging from 40°C to 50°C, sulphur-hydrogen type, with mineralization of 0.4 to 1.0 g/l and the healing properties. In the north-west part of the city, in the Lisi district, several boreholes were drilled and sulphur containing water of temperature from 60°C to 70°C is being used for house heating purposes.

From the West to East this horizon submerges beneath younger sediments. 20-30 km away from the “Lisi” area oil deposit was found in anticline structures.

Thus three main districts have been identified in the thermal water deposit of Tbilisi (from West to East): 1. Lisi-Saburtalo district, 2. Central - bathes or old thermal district, 3. Samgori- Sartichala district. Close connections between central and Samgori-Sartichala district has been established. The hydrodynamic interconnections between Lisi-Saburtalo and other districts are not clear and should be investigated. Nowadays low

Research workshop on Exploration and Exploitation of Groundwater and Thermal Water Systems in Georgia

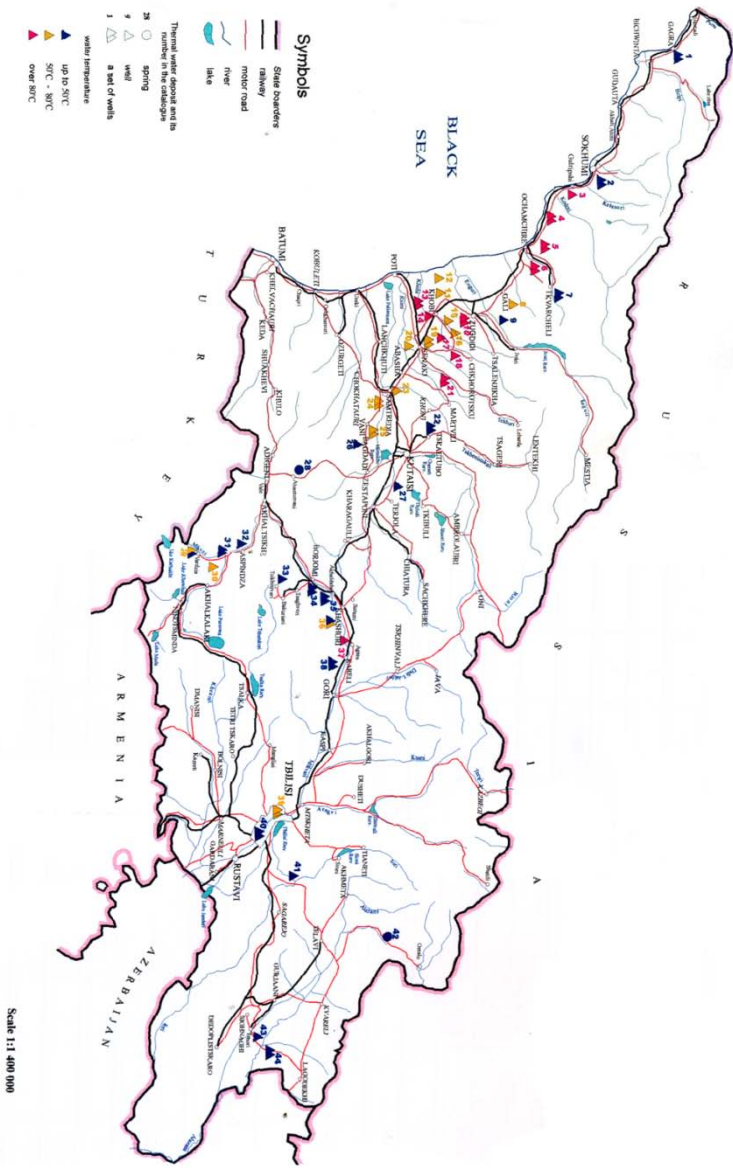

Fig. 1. Main geothermal fields in Georgia (Tsertsvadze N. et al. 1998)

temperature water of Central district is used for spa and hygienic purposes. High temperature (57-74 °C) waters of “Lisi” (wells 5, 7, 8) and Saburtalo (wells 1, 4, 6) are widely used for heating and hygienic purposes in total amount of 3800 m³ daily. It should be mentioned, that composition of water is similar in all three districts: low-mineralized 0.19-0.26 g/l, alkaline, sulphate-chloride-carbonate type, containing hydrogen sulfide.

Till now hydrodynamic relations between these three geothermal districts, as it was mentioned above (“Lisi”, “central” and “oil” deposit) is not properly investigated. It should be noted, that the intensive oil production at the oil field at 30 km to the north-east from the central thermal water deposit disturbed the regime of the central hydrothermal deposit and caused decreasing and desalination of spring in 1980s. Later, after stopping of intensive extraction, the regime of hydrothermal field was recovered. Besides, some anomalies of water level were discovered before and after local seismic events. Thus, it is evident that the regime of thermal waters is subjected to the influence of many factors: exogenous (precipitation, atmospheric pressure, tides) and the endogenous (earthquakes, creep, tectonic strain, oil production) impacts. Besides, there has been observed the decreasing of thermal water outflow in Lisi-Saburtalo area. After reviewing the data of discharge of river Mtkvari, and precipitation in the recharge area of thermal water deposit, revealed the

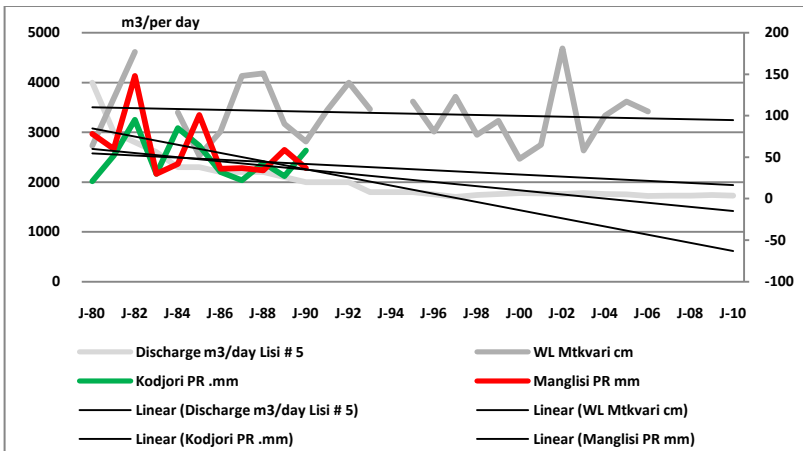

Fig. 2 Variation of parameters

interesting coincidence of decreasing in time precipitation, water level in Mtkvari and discharge of Lisi (well # 5) (Fig. 2)

Considering the above mentioned facts, we can assume that the decreasing of Tbilisi thermal water outflow, together with intensive and not correct exploitation of the wells, is a result of climate change processes that we observe in the region.

So it is evident that the absence of detailed regime observations of hydrogeothermal situation makes it impossible to develop a plan of rational environmentally reliable exploitation of these three deposits. (Buntebarth et al., 2009, Sakvarelidze et al., 2008)

Hydrodynamic digital model of Tbilisi thermal region and regularities of thermal field distribution

Urban centre Tbilisi is of a particular importance with its multilateral and dimensioned consumer existence, thermal waters resources, unlimited perspective of development and a population of 1.5 million. The use of heat energy of ground hydrothermal resources for therapeutic and heating aims is traditional worldwide, although detailed research into hydrodynamic and hydrochemical characteristics of this area is significant.

At present the scheme of exploitation of thermal waters in Tbilisi remains primitive, i.e. hot water goes from the well to user and then to sewerage. What is most important there is not any control of change in hydrodynamic parameters of deposit. As a consequence debits of separate wells decreases. No monitoring of wells under exploitation is operating and there is a lack of research of hydrodynamic relations between wells, which has negative effect on its exploitation.

To stop the tendency of decrease of pressure and debit of wells the idea of creation of an artificial geothermal circulation system (GCS) occurred. GCS would preserve geothermal deposit from depletion and expands exploitation time and what is most important, protect environment from pollution (bogging, thermal pollution), besides, liquidation of boiler houses decreases emission of carbon dioxide. And all that is directly connected to the climate change that we observe in southern Caucasus and generally all over the world.

Conclusions

Field hydrogeophysical investigations (tentative testing, regime hydrodynamic and microtemperature observations) have been carried out to assess the main thermo-hydrodynamic parameters of water containing horizons. Additionally, it has been confirmed, that the decreasing of thermal waters debit occurs not only due to no rational exploitation of them, it is affected by the world wide climate change processes.

Therefore, in future we recommend creation and implementation of geothermal circulation systems. This will help to achieve economical and ecologically approved exploitation of geothermal resources.

References

Tsertsvadze N., Buachidze G., Vardigoreli O., Vashakidze B., Inaishvili T., Kotrikadze N., Tsertsvadze L. “Thermal water of Georgia”, Book of Georgian Geothermal Association, Published under the financial support of the United States Agency for International Development (USAID) rendered through the "Eurasia" Foundation, 1998.

Buntebarth G., Kapanadze N., Kobzev G., Melikadze G. “Re-assessment of the Geothermal Potential of Tbilisi region: The Hydrodynamic Digital Model Project”, “Environment and Resources”, Association of Academics of Science in Asia Workshop, 25-27 September 2009, Izmir, Turkey, pp 154-161.

Sakvarelidze E., Glonti L., Melikadze G., Kobzev G. “Heat Field Modeling on the Example of Lisi-Saburtalo Area of Tbilisi Thermal Waters”, Institute of Geophysics Proceedings, Tbilisi №60, 2008, p.92-97.

ASSESSMENT OF THE POLLUTION PROBABILITY IN BORJOMI-BAKURIANI AREA BY APPLICATION OF HYDROCHEMICAL AND STABLE ISOTOPE METHODS

GEORGE I. MELIKADZE

Institute of Earth Sciences, Ilia State University

Borjomi field of thermal water is a source of famous mineral water, which is exported to dozens of countries and forms a significant part of the budget of Georgia. Recently, in connection with the construction of the Baku-Tbilisi-Geikhan pipeline, serious concerns arise with respect to vulnerability of water supply of the city of Borjomi caused by possible oil spills related to the operation of the pipeline. In the paper, we consider mainly the interaction between surface water and groundwater of the Bakuriani-Borjomi lava flow and the possibility of their pollution with hydrocarbons in the case of oil spilling. In order to define the possible pollution propagation, we apply hydro-chemical methods, stable isotope technology and other modern hydro-geophysical methods, which were adequate for better understanding of existing hydrogeological models, parameters and the risk of pollution is evaluated.

Keywords: Stable isotope, pipeline

1. Introduction

The section of the Tbilisi-Baku-Ceykhan (TBC) pipeline, situated on the southern periphery of the village Tsikhisjvari, is about 0.5 kilometres apart of the stripe where the Quaternary lava formation outcrops to the surface. This is the recharge area for the breccias aquifer formation, which underlay the lava formation. The precipitated surface waters are released in the form of a group of large springs in the areas of the villages Sadgeri, Daba and Tsemi. The resort Borjomi is mainly supplied with water from

the large spring situated on the right part of the deep and narrow gorge of the river Borjomula in about 7 km from the center of the resort. The local name of the spring is "Tsisqvilis Tskaro" (the mill spring) and it is also called "Sadgeri spring".

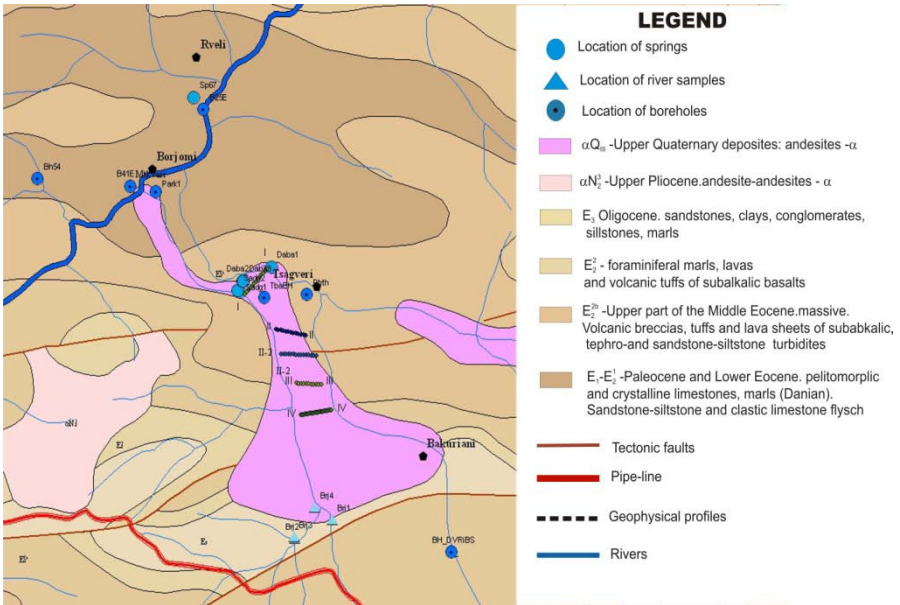

Fig. 1 Geological map of study area

The earlier data of the electric prospecting shows that the main water flow under the lava takes place 180 m below the surface, within the early Quaternary alluvial sediments of the paleo-channel of the river Borjomula. Two opinions are suggested in connection with environmental situation of this area in case of oil spill from the TBC pipeline. According to the first model, presented by expert of PB, Professor J. Lloid (Lloid et al., 2002), part of the water, infiltrated into the andesite-basalt lavas, is naturally discharged in the Borjomula, Gujareti and Tsemula river-beds and its outflows are on the slopes of river gorges, as shown on the diagram (Fig.2), i.e. spring water will not be polluted in case of oil spill.. The second model, presented by Prof. of Georgian Technical University U. Zviadadze (Zviadadze et al., 2002)), however, asserts that the bulk of the infiltrated

water that moves further down and reaches the waterproof layer (in this case the Upper Oligocene - Lower Miocene clay layer) and then moves towards the large Borjomula-Gujareti interfluves sheet, which means that oil pollution will reach drinking water source (Sadgeri spring).

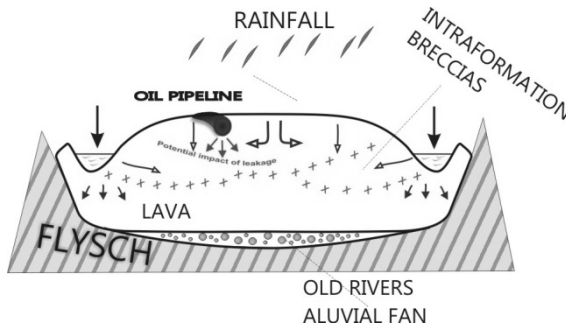

Fig. 2 Conceptual model

2. Data Analyses

In order to study the possibility of spoiling of drinking water in Borjomi area, the International Agency of Atomic Energy (IAEA) delivered the grant to Mikheil Nodia Institute of Geophysics. The main objectives of the project were to develop a conceptual model of water flows in the target area, with special focus on the interactions of the rivers and mineral springs with the surrounding aquifers; using nuclear technologies (natural isotopes) and hydro-chemical methods in selected areas for investigation of the recharge and discharge areas of the groundwater and possible propagation directions of pollution; and organizing a monitoring system against possible drinking water pollution.

2.1. Stable isotope and hydrochemical sampling

With a purpose of investigation of pollution's transfer possibility by water flows hydrochemical compounds of all hydrogeological formations and their connection in the region have been studied, namely: i. the mineral

water of Eocene-Paleocene flysch formation (5 boreholes), ii. fresh waters (5 springs and 1 boreholes), iii. waters of lava formation and surface waters/streams (5 sampling points). Totally, sixteen sampling points have been selected within the study area to collect information on chemical and isotopic composition of water.

From May 2007 till November 2009 ten sampling campaigns have been carried out. The main hydrochemical macro- and microcomponents of water sources have been tested by the field hydrochemical laboratory (Multi-340i/SET and Spectroquant®Colorimeters), which also have been purchased by the IAEA. Stable (^2H and ^{18}O) isotopes and tritium content have been measured in the several laboratories of Europe (Austria, Poland, Slovakia etc).

2.1.1. Hydrogeochemistry

Results were analyzed by AquaChem computer program. All water types were analyzed separately (Fig.3). Mineral water from boreholes №54, №41, №1, №25 in Borjomi belongs to sodium-carbonate type (Fig.4) with a high level of total dissolved solids (TDS).

Springs by composition (Fig. 5) are richer in magnesium that also points to the groundwater flow in contact with lava bodies along a way of water movement from lava flows .

In conclusion we can summarize that there are three groups of water by chemical composition: 1st group of mineral water, 2nd group of fresh water from the rivers and the last one from the springs, which is genetically connected with the second group.

2.2.2 Isotope data

Isotopic composition of water measured in eighteen sampling sites of the study area is presented in the Table1.

Research workshop on Exploration and Exploitation of Groundwater and Thermal Water Systems in Georgia

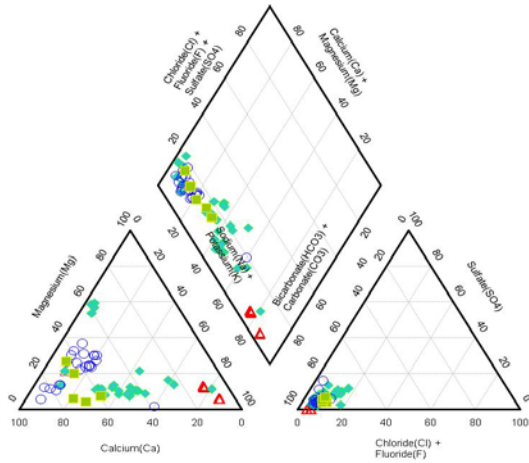

Fig. 3 All water groups

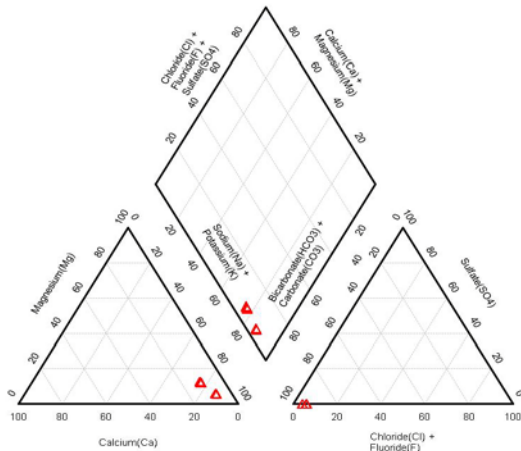

Fig. 4 Summary plot of chemical composition for all mineral waters

Research workshop on Exploration and Exploitation of Groundwater and Thermal Water Systems in Georgia

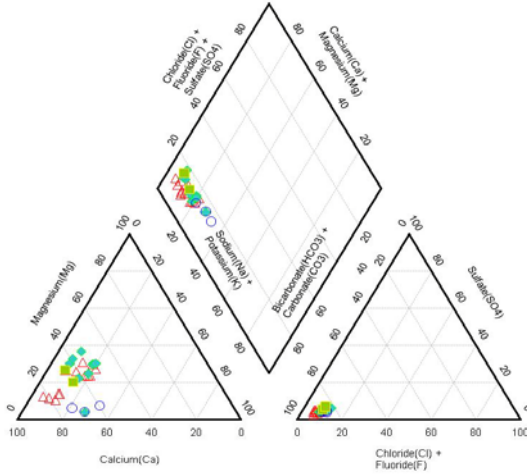

Fig. 5 Groups of all springs

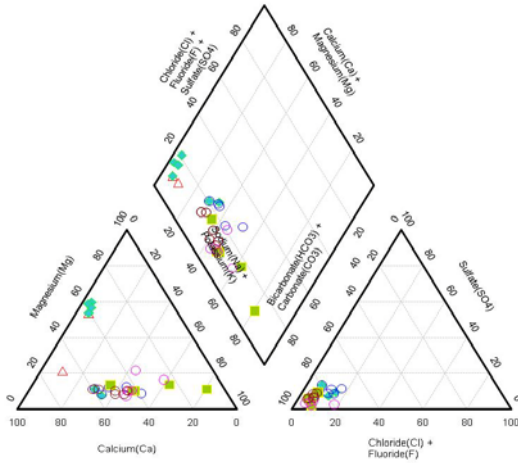

Fig. 6 Groups of all rivers

Table 1. Isotopic composition of water.

No.	Sampling site	$\delta^{18}\text{O}^{(*)}$ (‰)	$\delta^2\text{H}^{(*)}$ (‰)	d-excess ^{***)} (‰)	Tritium ^{***)} (TU)
1	Borjomi Park	-13.30 ± 0.05	-98.5 ± 1.1	7.9 ± 0.5	< 1
2	Daba 0 spring	-11.52 ± 0.03	-79.8 ± 1.1	12.4 ± 0.5	8.7 ± 1.2
3	Daba 1 spring	-11.56 ± 0.09	-80.5 ± 1.5	12.0 ± 0.5	10.5 ± 1.9
4	Daba 3 spring	-11.48 ± 0.09	-80.5 ± 1.6	11.3 ± 0.6	11.1 ± 2.2
5	Bakuriani Didi Veli	-13.54 ± 0.13	-92.5 ± 1.2	15.8 ± 0.5	< 1
6	Bakurianischali	-11.58 ± 0.22	-78.1 ± 1.7	14.5 ± 0.5	13.1 ± 1.9
7	Borjomula river	-11.20 ± 0.20	-77.6 ± 1.4	12.0 ± 0.7	13.6 ±
8	Borjomula river	-11.39 ± 0.32	-77.5 ± 1.5	13.6 ± 0.8	12.4 ± 1.9
9	Borjomula river	-11.33 ± 0.29	-77.5 ± 2.1	13.4 ± 0.6	16.6 ± 1.1
10	Borjomula river –	-11.39 ± 0.23	-78.1 ± 1.7	13.0 ± 1.1	15.2 ± 1.4
11	Tba borehole	-11.54 ± 0.35	-81.2 ± 1.4	11.2 ± 0.7	9.2 ± 0.9
12	Spring near borehole	-11.38 ± 0.18	-79.6 ± 1.4	11.4 ± 0.2	13.2 ±
13	Borjomi 25e	-12.62 ± 0.09	-99.8 ± 0.8	1.2 ± 0.4	< 1
14	Borjomi 41e	-13.20 ± 0.11	-99.4 ± 0.8	6.1 ± 0.9	< 1
15	Likani 54 borehole	-14.05 ± 0.06	-103.9 ± 1.1	8.5 ± 0.5	< 1
16	Sadgeri spring	-11.71 ± 0.15	-80.9 ± 2.1	12.8 ± 0.7	9.3 ± 0.9

The $\delta^2\text{H} - \delta^{18}\text{O}$ relationship (Fig. 8) reveals several distinct features of the sampled waters. All collected river samples (Borjomula river and its three branches, Bakurianischali river) form a tight cluster of points located above the GMWL.

River and spring samples reveal generally high, although quite variable tritium concentrations. Average tritium content in river samples is equal to 14.3 ± 0.9 TU (Tritium Unit- it means there are 14.3 atoms of tritium per 18atoms of hydrogen). For springs (Daba 0, 1 and 3; Sadgeri spring) the average tritium content is significantly smaller (9.9 ± 0.5 TU). The deep boreholes most probably do not contain any tritium, although the reported data scatter considerably.

Somewhat lower tritium value in springs compared to rivers, combined with slightly lower $\delta^{18}\text{O}$ and $\delta^2\text{H}$ values and might indicate the presence of additional water component, recharged at higher elevation and with longer mean transit time of water to the springs.

Research workshop on Exploration and Exploitation of Groundwater and Thermal Water Systems in Georgia

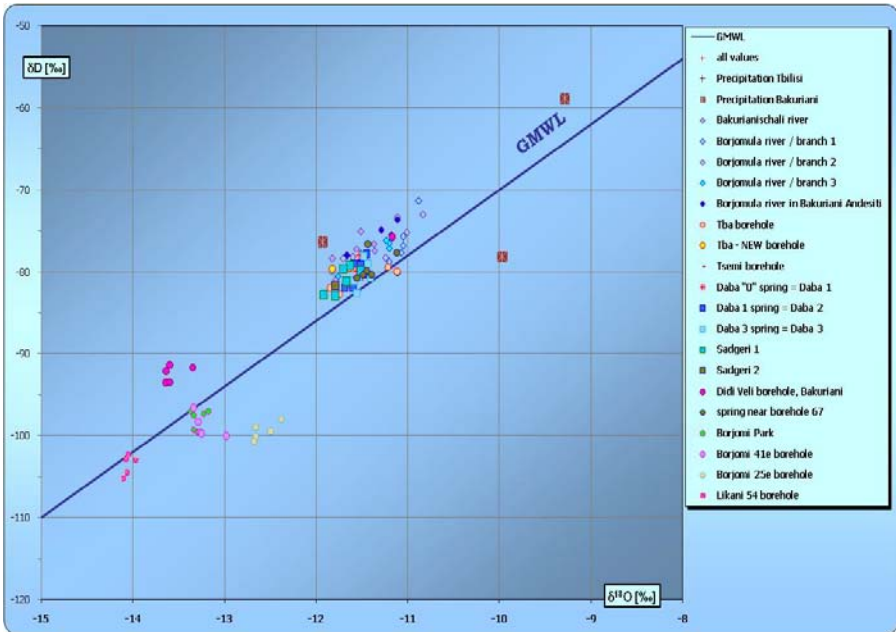

Fig. 7 All data: $\delta^{18}\text{O}$ [‰] & δD [‰] vs SMOW

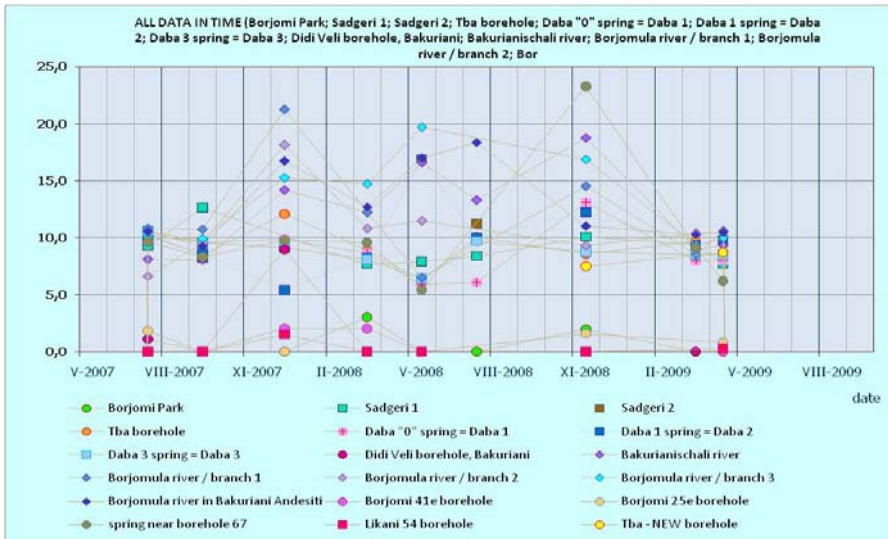

Fig. 8 All data: ^3H [TU] vs. TIME

2.2. Organization of monitoring with warning system in the areas of possible pollution

In the areas of potential pollution, namely, in the recharge, stream flow and discharge areas three devices of special monitoring equipment “SEBA” have been installed. Water level, temperature and electric conductivity are observed regularly at these sites. Multi-parameter measurements are conducted at 15 or 30-minute time-intervals. In order to organize alarm-system, data are transmitted and accumulated in the real time mode with requested frequency to the central laboratory. The data are connected to other monitoring results. As a result, the regime-defining factors of groundwater (seasonal and diurnal variations etc) as well as amplitudes of possible variations were ascertained.

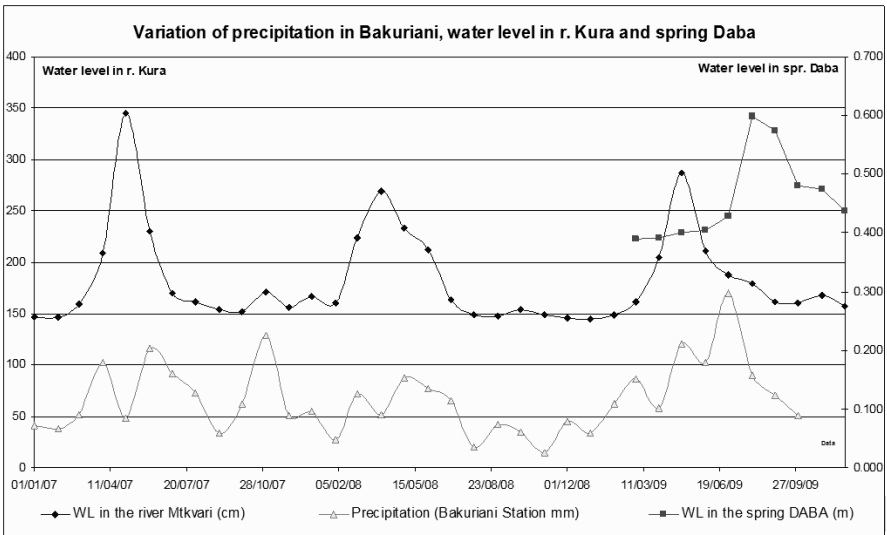

Fig. 9 Variation of precipitation in Bakuriani and water level in Daba spring and river Kura (nearby Likani station).

We compared and analyzed all data which were collected during observation on the monitoring stations. Seasonal variation in the river Mtkvari and Daba spring is fixed, which is related to precipitation in

Borjomi-Bakuriani area, but the maximum of seasonal variation in the Daba spring appears later than in river. It means that the pathway of water from recharge area to spring discharge area is longer (by 30-40 days) than the pathway to the river. In future, this system may help to fix and inform us on the rate of pollution propagation in the aquifer after oil spill.

3. Conclusions and recommendations

According to geological, hydrogeological, hydrogeochemical, isotope and other investigations, carried out in the Borjomi-Bakuriani test area we conclude that the waters of rivers Borjomula and Gudjaretis-tskali are formed simultaneously in the same recharge area, namely, Bakuriani-Tsikhisjvari lava plateau. After infiltration into the lava sheet “spring water” flows along ancient river valley in Quaternary alluvial formation and is discharged at Sadgeri and Daba springs.

This is confirmed by isotope data: the stable isotope data presented above reveal that Sadgeri spring, which supplies the Borjomi resort with potable water, as well as Daba springs, carry essentially fresh water, isotopically and chemically similar to that of Borjomula river and Tba borehole drilled in the lava bed. Stable isotope data also suggest that all springs mentioned above contain additional water component, recharged at higher elevation, with longer mean transit time to the discharge points. This hypothesis is supported by significantly lower tritium content in springs compared to rivers.

Water flows along breccia rocks and that is why their pathway to surface is longer than the route of waters flowing to rivers. This opinion is confirmed by chemical data: the springs’ waters are richer in magnesium than river waters.

By monitoring data, it has been found that the maximum of seasonal variation in the Daba spring is fixed later (30-40 days) than in river Mtkvari. It means that the pathway of water from recharge area to spring discharge area is longer than the pathway to the river.

Thus the possibility of Borjomi city drinking water pollution in case of pipeline accident is very realistic and corresponds to the model of Prof. Zviadadze. In this connexion it is necessary to take effective measures for protection of water source areas.

Acknowledgements

Author acknowledges support of International Atomic Energy Agency # GEO8003 “Using Isotope Techniques to Assess Water Resources in Georgia”

4. References

Lloid J.W., 2002: Review of Hydrogeology pertinent to the river Borjomula catchments and Gudjaretis Tskali catchments (KP175-KP192). GIOC.

Zviadze et al. 2002: Ecological problems connected with Baku-Tbilisi-Geiha pipeline. Science and Technology #10-12

Beradze R. et al. 1985: Report on 1:25 000 scale geological prospecting K-38-75-b-v-g and K—38-75-G -a-b (in Russian), Georgian Geological department.

Chikhelidze S., 1954: Hydrogeology of Sadgeri spring, Geological report, Georgian Geological department.

Chkhaidze D. et al. 1988: Report on 1:25 000 scale special hydrogeological prospecting works on the Borjomi mineral water resources, Georgian Geological department. (in Russian)

Chkhaidze D. et al.: Report of detail investigation of Borjomi mineral water deposit in 1978-1982, Geological report, Georgian Geological department.

Gabechava J. et al., 2000: Study of water regime of Daba spring (Borjomi district), Geological report, Georgian Glass and Mineral water Co.

Meskhia A. et al., 2002,: Geophysical investigations for groundwater study nearby Daba village in Borjomi region, Georgian Glass and Mineral water Co.

Skhirtladze N. 1958: After Paleogen effusive in Georgia (in Russian)

APPLYING TEMPERATURE AND PRESSURE MEASUREMENTS FOR ESTIMATING THE SIZE OF A WATER RESERVOIR

G. BUNTEBARTH

Clausthal University of Technology, Germany,

G. MELIKADZE

Institute of Earth Sciences, Ilia State University

Beside geological methods for determination of the size of a water reservoir, temperature and pressure records in boreholes are used as complementary means. They can be applied, if several wells are available. If a hydraulic connection exists between two given wells, a variation in one well can also be monitored in the second one. On the other hand, a displacement of an aquifer can be found, if a change in one borehole does not affect the temperature or water level in another borehole.

The water reservoirs in and near to Tbilisi are separated aquifers for which the hydraulic connection exists between the wells in every reservoir. Additionally, strong pressure changes in the more distant Samgori oil reservoir affect also the hydrothermal field of the central thermal water reservoir at Tbilisi.

Keywords: Micro-temperature, oil and water reservoir

Introduction

A sustainable exploitation of a water reservoir is based on the knowledge of several structural, petrophysical, hydrogeological and meteorological data that can affect a water balance. One important part of them is the size of the reservoir. Its extent determines the accumulated capacity, i.e. the total volume, if water should be used for drinking or baths or the heat capacity, if thermal energy is to be extracted from hot water.

Geological mapping provides the structure near to the surface and the subdivision into blocks by visible faults. Geophysical prospecting methods can clear up the deeper structure, so that a layered model can be estimated. For more detailed studies, boreholes are necessary in order to make hydrogeological experiments and to monitor the water movement which is caused by geodynamical effects, by tectonic activities, by changes of recharge conditions and at least by man-made activities which affect the hydrological pressure in the subground. The aim of this paper is to demonstrate in which way continuous temperature and pressure measurements can be used to determine boundaries of water reservoirs.

Method

Temperature measurements are performed in such a way that highly resolving Quartz-thermometers are placed at one or more depths and monitoring is extended over several months by reading the thermometer three or four times an hour or twice as a minimum. A few readings are stored in the instrument and every three hours they are transmitted to the laboratory using the local GSM network. In the case of lacking a GSM net which can occur in mountainous areas or if no electricity is available, the onboard data logger can keep the data for several weeks until they are read by a computer.

For precise measurements of the temperature, it must be known how much is the measured value affected by variations of the ambient temperature. Because this temperature is also recorded, its influence can easily be determined. Fig. 1 displays a record of the instrument temperature and a contemporary record of a temperature sensor. The strong coincidence of the variations is free from doubt and the analysis yields a temperature sensitivity of $\Delta T/T = \pm 0.35 \text{ mK/K}$, if the used time base has a stability of $\pm 1 \text{ ppm}$ at 16 MHz within $0 < T < 70 \text{ }^\circ\text{C}$. If the instrument is kept within the borehole, the diurnal temperature affects the measurements within $\Delta T = \pm 0.5 \text{ mK}$. This effect can be eliminated, if daily mean values are calculated. Longer weather periods can also be filtered out, if the date and time are used together with the instrument temperature in order to determine a function of correction. For more precise measurements, i.e. if climate variations are to be monitored, a more stable time base must be installed, e.g. an oven Quartz-oscillator.

During a given time interval records are necessary at two boreholes at least. The fluctuations and the trend of records in both boreholes provide the arguments whether the wells are hydrologically connected or not. If the boreholes intersect the same aquifer, the temperature records correlate between themselves. This correlation even does not need any mathematical treatment. The inspection by eyes is sufficient for a decision whether a hydrological connection can be realized or not.

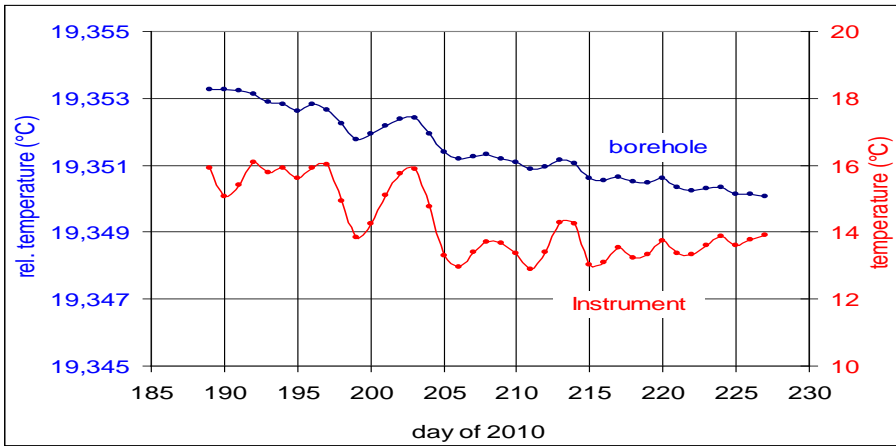

Fig. 1: Influence of the instrumental temperature changes on the measurements

In the case, if a reservoir is used discontinuously by pumping water from wells and the temperature is monitored at another borehole, the records would display whether a connection exists between the exploitation area and the borehole of monitoring.

Pressure measurements below the water table or within artesian wells are also used in the same manner as temperature records, because in both cases the physical properties are caused by water movements up or down. However, the fluctuations of pressure are higher near the water table than that of the temperature at 100 or 200 m of depth. The variations are reasoned by geodynamical effects like Earth's tides as well as by tectonic activities. Additional changes are monitored according to variations of the atmospheric pressure and after rainfall in recharge areas.

The atmospheric pressure is resolved with $\Delta p = 1$ mbar (= 1 hPa) and the measurement of water pressure with $\Delta p = 0.1$ mbar (= 0.1 hPa). The onboard temperature of the instrument as well as date and time are recorded additionally to the pressure.

The recorded data are kept at the instrument and stored in the memory for a few hours until they are transmitted as a SMS to the laboratory. The data can also be stored for several weeks, if the transmission mode via GSM is not possible. In this case, they are read to a computer every 2 or 3 weeks.

The visual inspection of the records of two boreholes already determines whether the wells are hydrologically connected or not. In the case that a reservoir is exploited more or less discontinuously and a further borehole intersects the same reservoir, the pressure variations within the reservoir also occur in the borehole of observation.

Near Tbilisi three water resp. Thermal water reservoirs are located, i.e. the Central Thermal Field, the Saburtalo field and the Samgori field. During the time of monitoring, three boreholes could be used for measurements. They are located within the areas which are assumed as the water reservoirs by the geological structure. However, there is no proof whether the visible faults separate the reservoirs at the depth of the aquifer. The wells are located near to the villages of Lisi and Varketili as well as in the centre of Tbilisi at the Botanical Garden. Three records may demonstrate in which way the reservoirs can be discriminated.

The well Botanical Garden shows a high fluctuation of the temperature of which the shape repeats diurnally and additional peaks, more or less continuously, are realized. These changes coincide with the exploitation of the thermal water for the baths in the centre of Tbilisi. If less water is used, the temperature increases. It occurs regularly during the evening and in the night. In the early morning when the demand of water increases, the temperature decreases. The onset of the pumps for filling basins creates sharp peaks in the temperature records as demonstrated with fig. 2. The changes of the instrument temperature with $\Delta T = 5$ °C would cause a variation of 1.5 mK which cannot be recognized at the total variation of 20 mK. It can be concluded that the borehole Botanical Garden is very well connected at a high permeability with the thermal water reservoir under exploitation.

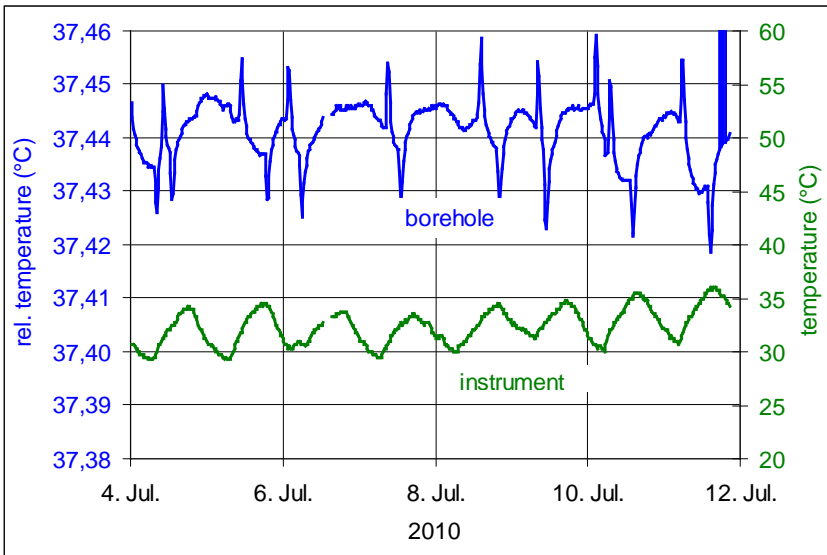

Fig. 2: Depth of the water level in the borehole Botanical Garden (Central Thermal Field)

Pressure records at the Saburtalo thermal water reservoir and at the Central Thermal Field do not display any coincidence at the first glance as fig. 3 shows. However, the time delayed increase of the water level of four days at the Botanical Garden in comparison to that one at Lisi may suggest a weak connection between the regions of high permeability. Even the regions are separated by a mapped fault zone their vertical dislocation is, probably, not so large that the aquifer is interrupted.

At the area of the Samgori water reservoir, the borehole Varketili is located and reaches a depth at which the Lower Eocene is encountered. It is the same lithology which contains the Central Thermal Field. A contemporary record at this well and at the borehole Botanical Garden is plotted at fig. 4. During September, the water level descends at the Botanical Garden by $\Delta z = 10$ cm, but at Varketili by $\Delta z = 25$ cm. However, the subfollowing

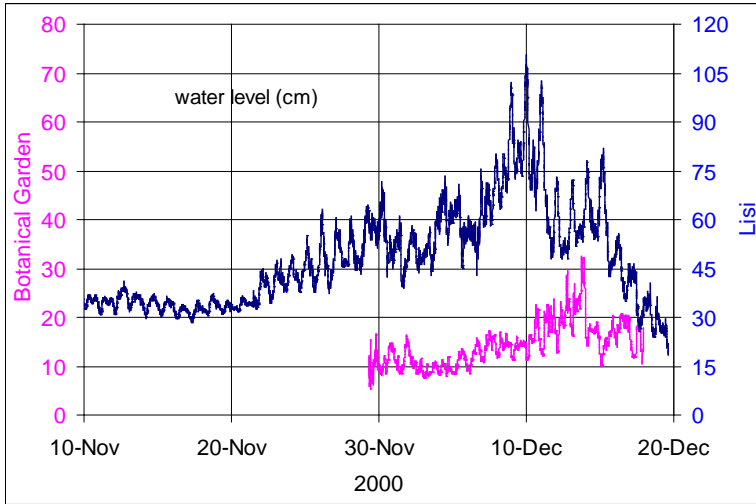

Fig. 3: Depth of the water level in the boreholes Botanical Garden (Central Thermal Field) and Lisi (Saburtalo Thermal Field)

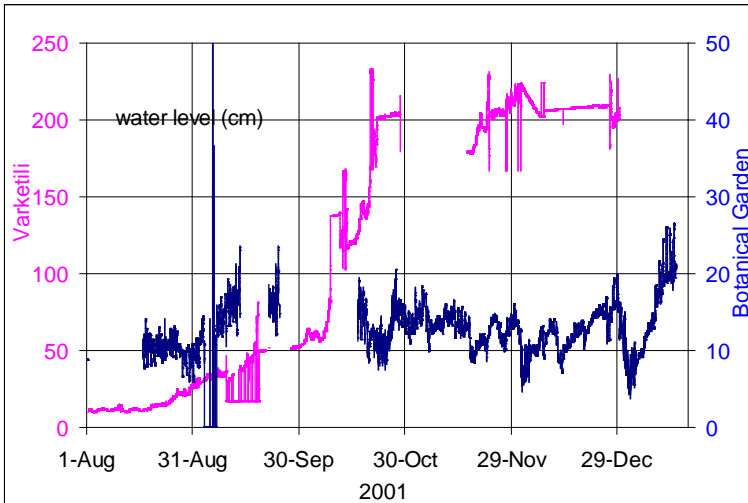

Fig. 4: Depth of the water level in the boreholes Botanical Garden (Central Thermal Field) and Varketili (Samgori Thermal Field)

large descend of $\Delta z = 150$ cm at Varketili corresponds with the small ascend of $\Delta z = 10$ cm at the Botanical Garden in October.

The first descend is in phase and seems to be caused by the effect with a connection of low permeability between both reservoirs. The second water level changes are contrary and have quite different amplitudes. It seems that the drop down at the Samgori field has no effect at the Botanical Garden within two months. Buntebarth et al. (2005) report a longterm influence of the oil exploitation which occurred in the eighties of the last century. The more oil was extracted from the oil reservoir the less thermal water could be exploited at the central field. Finally, the thermal water ceased. These data also supports the assumption that a weak connection between both water reservoirs exists. They are separated by a zone of high permeability. This conclusion is also supported by the high frequency changes which occur in the Central Thermal Field and which are not recorded at the Samgori water reservoir.

Conclusion

Temperature and pressure records are useful means in order to get complementary information on the extent of a water reservoir. In the case of different adjacent reservoirs, the recorded physical properties yield the degree to which the fields are interconnected. Using pressure and temperature measurements which express the water movement in the subground can provide a rough qualitative estimation of the permeability within a water reservoir and between adjacent reservoirs.

References

Buntebarth, G., Chelidze, T. & Melikadze, G. (2005): Hydrodynamic and microtemperature monitoring in seismic areas: Tbilisi Hydrothermal Field, Georgia, Caucasus, in: G. Buntebarth & T. Chelidze (eds.), Time-dependent microtemperature and hydraulic signals associated with tectonic/seismic activity, Inst. Geophys., Georgian Acad. Sci., Tbilisi 2005, pp.109-144.

PETROPHYSICAL INVESTIGATIONS ON LOWER EOCENE SANDSTONES OF TBILISI REGION

ANDREAS WELLER, WOLFGANG DEBSCHÜTZ,
*Institute of Geophysics, Clausthal University of
Technology, Germany*

NINO KAPANADZE
*Institute of Earth Sciences, Ilia State University, Tbilisi,
Georgia*

Porosity and permeability are the most important petrophysical quantities related to water storage and transport in porous media. Hydrogeological models require reliable permeability estimation for the aquifers. The direct measurement of permeability is restricted to borehole locations and provides only integrated values.

Petrophysical models describe relations of permeability to other measurable quantities. The spectral induced polarization (SIP) and the nuclear magnetic resonance (NMR) method have been successfully applied in permeability prediction of sandstone formations.

A first set of rock samples from Georgia has been investigated to determine a variety of petrophysical quantities and to check whether the available models are applicable for permeability prediction.

Keywords: Petrophysical investigation, rock properties, permeability

Introduction

The Tbilisi Hydrothermal Field exploits water from the Lower Eocene sedimentary rocks as well from the Middle Eocene. The deposits of the Lower Eocene are widely distributed in Tbilisi region. They are composed primarily of sandstones, limestones, and marls. The total thickness of the formation varies between 2100 and 2800 m.

A detailed characterisation of the reservoir rocks is needed to design reliable hydrogeological models. For this purpose, drill cores from different depths and lithologies would have been needed to determine the relevant petrophysical quantities. Porosity and permeability are the most important quantities related to water storage and transport in porous media. Porosity and indications of fracture can also be derived from well logging. Because logging curves and core material are not available from boreholes of the Tbilisi Hydrothermal Field, samples could only be collected from outcrops.

In our study, sandstone samples have been collected from an outcrop of the Lower Eocene sandstone formation in Tbilisi-Vake where it is cut by the construction of a new motorway. The coordinates of the outcrop location are 41°42'56"N, 44°44'47"E. The highly consolidated sandstone samples show weak variation in the colour ranging from light grey to dark grey. A detailed mineralogical and petrological description is still missing.

Petrophysical measurements were performed to provide detailed data to describe the physical properties and their variation.

Methods and data

A total of ten hand specimens were collected along the outcropping sandstone formation of Lower Eocene. Cylindrical samples with a length of 30 to 40 mm and a diameter of 20 mm were drilled from the hand specimens. Most devices in the petrophysical lab require these standardized samples that have to be inserted in special sample holders.

Grain density, natural raw density and porosity of all samples were determined by triple weighting: in dry state, in fully saturated state, and Archimedes' weighing in a water basin. The samples were saturated with low salinity brine. The resulting minima, maxima and mean values of the petrophysical quantities are compiled in Table 1.

Table 1: Minima, maxima and mean value of petrophysical quantities determined on Lower Eocene sandstone samples of Tbilisi region.

	Minima	Maxima	Mean
Grain density in kg/m ³	2578	2718	2651
Natural raw density in kg/m ³	2412	2697	2541
Porosity in %	1.2	10.5	5.6
Permeability in mD	3.5 10 ⁻⁵	1.5 10 ⁻¹	6.7 10 ⁻³
DC resistivity in \square m	31.5	819	95.0
Total chargeability	0.0527	0.138	0.0852
Mean relaxation time in ms	14.3	198	53.4
Non uniformity parameter	1.83	3.51	2.85
Resistivity formation factor F	3.4	96.0	10.5
NMR: T_1 in ms	2.91	15.1	7.85
NMR: T_2 in ms	0.747	3.99	1.62
S_{por} in 1/ μ m	3.8	230	52.4
Magnetic susceptibility in 10 ⁻⁶ (SI unit)	209	637	328

The mean value of grain density is close to the value of quartz mineral that is expected for sandstone. The minima and maxima values indicate variation in the mineralogical composition of the samples. The natural raw density determined for the fully saturated samples shows relatively large values between 2412 kg/m³ und 2697 kg/m³ which are caused by low porosity that varies between 1.2 % and 10.5 %.

The permeability of the sandstone samples was determined by a gas permeameter using nitrogen as the flowing fluid. Klinkenberg correction has been applied. The resulting permeability values cover nearly four decades in logarithmic scale with a range from 0.035 μ D to 0.15 mD and a geometric mean value of 6.7 μ D.

The electrical properties of the sandstone samples were acquired in the frequency range from 2.8 mHz to 750 kHz by a SIP Fuchs equipment (Radic Research, Germany) that provides spectra of resistivity amplitude and the phase shift between injected current and observed voltage signal. Both spectra can be combined to derive the frequency dependent complex conductivity of the samples. The measurements of spectral induced polarisation (SIP) were performed under ambient conditions at a constant temperature of about 20 °C. The samples were fully saturated with a

sodium-chloride solution of 0.56 g/l resulting in a brine conductivity of 0.1 S/m.

For evaluating complex electrical data, models are fitted to the amplitude and phase angle spectra by adjusting their parameters. Nordsiek and Weller (2008) suggested an approach where the measured complex resistivity spectra $\rho(\omega)$ are regarded as a superposition of Debye models:

$$\rho(\omega) = \rho_0 \cdot \left(1 - \sum_{j=1}^n m_j \cdot \left(1 - \frac{1}{1 + i\omega\tau_j} \right) \right) \quad (1)$$

with m_j and τ_j being the parameters of a single relaxation term. Decomposition of the spectra into a number of Debye models results in a distribution of relaxation times which is summarized by four integrating parameters. The first parameter is the DC resistivity ρ_0 that results from the low frequency extrapolation of the amplitude spectra. ρ_0 is a common parameter that occurs in most other mathematical models describing IP spectra.

The original definition of chargeability (Sumner, 1976)

$$m = \frac{\rho_0 - \rho_\infty}{\rho_0} \quad (2)$$

quantifies the relative change of resistivity in a frequency scan with ρ_0 being the low frequency resistivity limit and ρ_∞ the high frequency asymptotic value. The polarization magnitude m_j computed for each individual Debye relaxation specifies the resistivity change in a narrow frequency interval. The summation across the considered frequency range yields a global polarization magnitude term, defined here as total chargeability

$$m_t = \sum_{j=1}^n m_j \quad (3)$$

that is considered to be the second integrating parameter of a Debye decomposition.

A relaxation time τ is used to quantify the temporal behaviour of a decay process according to an exponential function $\exp(-t/\tau)$. A small relaxation time τ describes a fast decay process. The Debye decomposition assumes a temporal sequence of individual decay processes with specific

relaxation times τ_j . The third integrating parameter defines the mean relaxation time

$$\bar{\tau} = \exp\left(\frac{1}{m_t} \sum_{j=1}^n m_j \ln(\tau_j)\right) \quad (4)$$

as the weighted logarithmic mean of all relaxation times τ_j with the individual polarization magnitudes m_j being the weighting factors.

The fourth integrating parameter of Debye decomposition is defined in analogy to the degree of non-uniformity of grain-size distribution curves. The non-uniformity parameter

$$U_\tau = \frac{\tau_{60}}{\tau_{10}} \quad (5)$$

characterises the width of the relaxation time distribution with τ_{10} and τ_{60} marking those relaxation times whereby in a cumulative curve 10 % and 60 % of the total chargeability is reached.

The resistivity formation factor F results from the ratio of the resistivity of the fully saturated sample to the resistivity of the saturating brine. In the case of low-salinity brine, the ratio has to be corrected considering the effects of interface conduction. The variation of all electrical parameters is compiled in Table 1.

Nuclear magnetic resonance (NMR) method is widely applied in pore space characterisation. The magnetic relaxation of hydrogen in a wetting pore fluid of rocks is controlled by slow relaxation in the free pore fluid and fast relaxation in the direct vicinity of the pore surface. In case of fast diffusion exchange between free pore fluid and the fluid at the pore surface, the magnetization in the pores remains uniform. The relaxation time becomes proportional to the volume to surface ratio of the pores (V_{por}/S) or proportional to the radius of pores if a suitable pore model is considered. In rocks with a distribution of pores of varying size, a spectrum of different relaxation times is determined. The resulting mean relaxation time represents a valuable petrophysical quantity that is related to an average pore size.

Two different types of relaxations can be distinguished. The longitudinal relaxation time T_1 characterizes the increase of magnetization parallel to the

static magnetic field and the transversal relaxation time T_2 the decrease of magnetization perpendicular to the static magnetic field.

The pore volume related specific internal surface $S_{por} = S/V_{por}$ can be measured by nitrogen adsorption method. The S_{por} -values determined for the Lower Eocene sandstone samples vary between $3.8 \mu\text{m}^{-1}$ and $230 \mu\text{m}^{-1}$.

The volumetric magnetic susceptibility of the cylindrical samples was determined in a kappa bridge. The resulting values of more than $200 \cdot 10^{-6}$ SI indicate a larger content of paramagnetic minerals in the investigated sandstones samples.

Discussion

The rock samples of the Lower Eocene are sedimentary deposits of a shallow marine environment and consist of mainly effusive components like quartzite, feldspar, plagioclase, mica, calcite, in some cases pyroxene as well as undefined clay minerals. Though the hand specimens have been collected at a single location their petrophysical properties show a wide variation for all determined parameters. It can be concluded that the Lower Eocene sandstone formation is characterised by a considerable degree of heterogeneity not only of the petrophysical properties but also of its composition. A main component of the samples is calcium carbonate of two generations. Chemical analysis yields contents between 7% and 60%. The high carbonate content and pyroxene in other samples result in the high density. The carbonate also yields the low porosity as well as permeability. Because of its easy solubility, a solution causes a high permeability at a relatively low porosity which can be realized at a few samples.

A closer look should be done at the relations between the petrophysical quantities. Figure 1 displays the relation between fractional porosity and measured permeability showing a general increase of permeability with increasing porosity. A power-law fit results in a porosity exponent of 3.63 and a coefficient of determination $R^2 = 0.239$.

Considering our sandstone samples, the Archie-equation (Archie, 1942) relating fractional porosity Φ and resistivity formation factor F gets the form:

$$F = \frac{0.186}{\phi^{1.39}}. \quad (6)$$

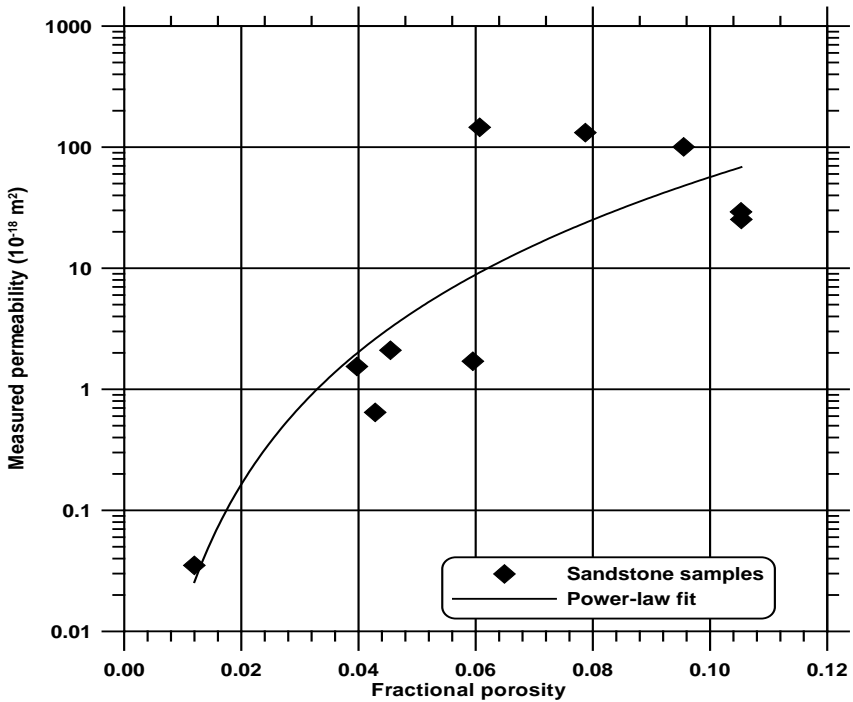

Figure 1: Relation between fractional porosity and permeability of Lower Eocene sandstone samples.

In comparison with similar formulas that have been derived for other sandstone formations, the porosity exponent is rather small and does not reflect the high degree of consolidation.

Based on a fractal pore space model and considering an extended database, the PaRiS-equation relates the specific internal surface S_{por} (in $1/\mu\text{m}$) and the product of permeability K (in mD) and resistivity formation factor F (Pape et al., 1987):

$$K \cdot F = \frac{475}{S_{por}^{3.1086}} \cdot \quad (7)$$

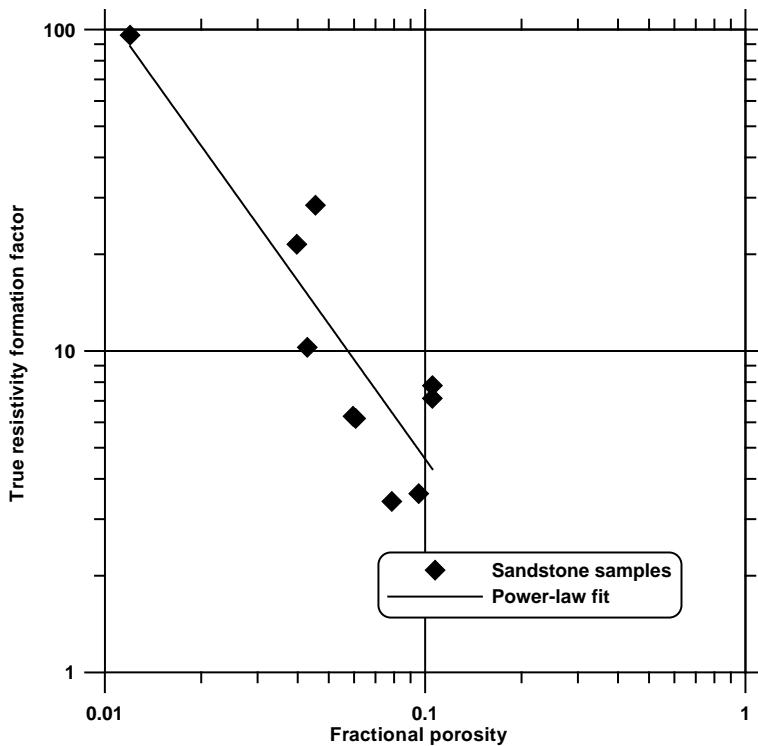

Figure 2: Relation between fractional porosity and resistivity formation factor of Lower Eocene sandstone samples.

Figure 3 displays the comparison between the PaRiS-equation and the data of our samples. It becomes obvious that the general trend of our samples does not follow the PaRiS-equation. In a modified version, this equation can be used for permeability estimation on the basis of SIP data (Weller and Börner, 1996). The resistivity formation factor F is derived from the real part of conductivity and the specific internal surface S_{por} is related to the imaginary part (Weller et al., 2010a). The latter relation could not be confirmed by our data. Thus, a modified PaRiS-equation cannot be recommended for permeability prediction.

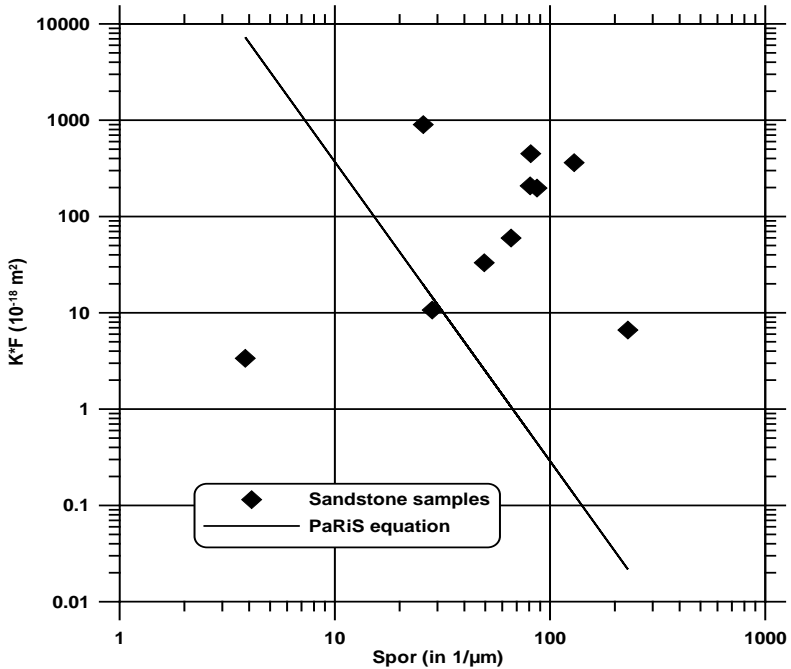

Figure 3: Relation between specific internal surface S_{por} and the product of permeability K and resistivity formation factor F for Lower Eocene sandstone samples.

An alternative approach for permeability prediction is based on NMR data using porosity and mean relaxation time. The following equation

$$K_{NMR} = 9.35 \cdot 10^{-5} \cdot T_2^2 \cdot \Phi^4 \quad (8)$$

was determined for a sample set of a cretaceous sandstone formation (Weller et al., 2010b) with K_{NMR} in mD and T_2 in μs . Equation 8 was used for permeability prediction for our sandstone samples. Figure 4 shows the comparison between measured and predicted permeabilities. A strong underestimation is achieved for the three samples with the highest permeability.

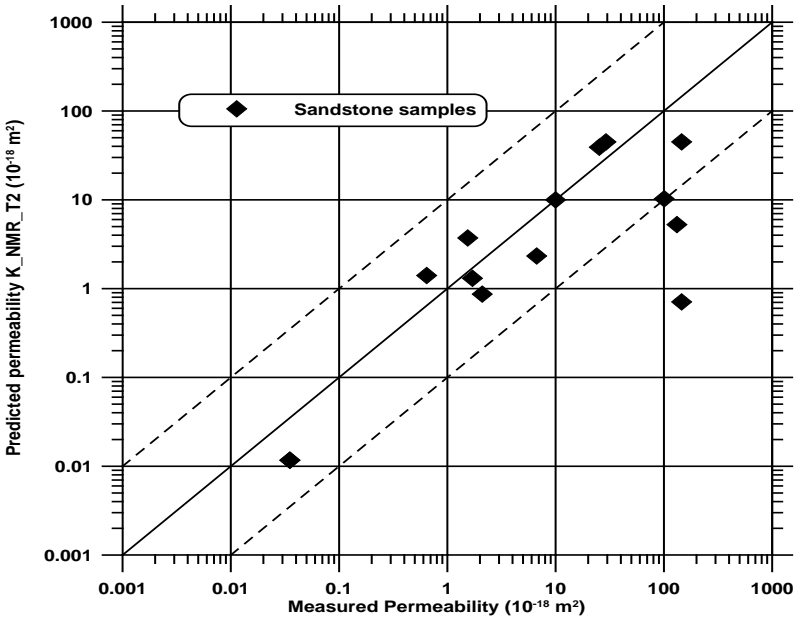

Figure 4: Permeability (in 10^{-18} m^2) calculated from NMR mean relaxation time T_2 and porosity Φ plotted versus permeability measured on Lower Eocene sandstones samples. The dashed lines indicate a distance of one decade to both sides of the measured permeability.

Conclusions

The ten Lower Eocene sandstone samples collected from a single outcrop in Tbilisi show a wide variation in their petrophysical quantities. The samples are generally characterised by low porosity (below 11 %) and low permeability (below 0.2 mD).

The petrophysical database has been used to verify relations between different quantities. A general increase of permeability with increasing porosity has been observed. The Archie equation results in a low porosity exponent. The validity of PaRiS-equation could not be confirmed by our data. Thus, permeability prediction based on SIP data has not been possible so far. However, NMR and porosity data yield more reliable values for

permeability prediction. But also this approach provides a considerable underestimation for the samples with the highest permeability.

Our study, which is based on ten sandstone samples, can only be regarded as a first step of a petrophysical characterisation. More samples of different outcrops and core samples of different depth are needed to improve the statistical relevance of the investigations. The ten samples have shown that different petrophysical relations that have been confirmed by a variety of sandstone formations are not applicable to the Lower Eocene sandstones of Tbilisi region. Additional mineralogical and petrological investigations are recommended to describe the structure and texture of this sandstone formation.

References

- Archie, G. E.**, 1942, The electrical resistivity log as an aid in determining some reservoir characteristics: Transactions of the American Institute of Mining, Metallurgical, and Petroleum Engineers, 146, 54–62.
- Nordsiek, S., and A. Weller**, 2008, A new approach to fitting induced-polarization spectra: Geophysics, 73, no. 6, F235–F245.
- Pape, H., L. Riepe, and J. R. Schopper**, 1987, Theory of self-similar network structures in sedimentary and igneous rocks and their investigation with microscopical and physical methods. Journal of Microscopy 148, 121-147.
- Sumner, J. S.**, 1976, Principles of induced polarization for geophysical exploration: Elsevier, Amsterdam.
- Weller, A., and F. D. Börner**, 1996, Measurements of spectral induced polarization for environmental purposes: Environmental Geology, 27, 329-334.
- Weller, A., L. Slater, S. Nordsiek, and D. Ntarlagiannis**, 2010a, On the estimation of specific surface per unit pore volume from induced polarization: A robust empirical relation fits multiple datasets: Geophysics, 75, no. 4, WA105-WA112.
- Weller, A., S. Nordsiek, and W. Debschütz**, 2010b, Estimating permeability of sandstone samples by nuclear magnetic resonance and spectral induced polarization: Geophysics, 75, no. 6, E215-E226.

INVESTIGATION OF THE HEAT CONDITIONS OF TBILISI THERMAL WATER DEPOSIT

EVGENY SAKVARELIDZE

Institute of Earth Sciences, Ilia State University

LUDMILA GHLONTI

Institute of Hydrogeology and Engineering Geology

In order to determine the thermal properties of the rocks (the method of horizontal impulse heat source), an experimental device has been developed. The thermal properties of the rock from the study area have been measured taking into account the influence of humidity on them. Based on experimental and published data the mean value of a heat flow as well as the heat conductivity was determined. The obtained data were used to calculate the temperature at the surface of the aquifers and the depth of the existing of thermal waters (~70 °C) and water-steam mix (~130 °C).

Keywords: Thermal parameters, rock property.

1. Object and the purpose of investigations

Study of Tbilisi deposit thermal field becomes especially urgent due to modern demand of power resources. Availability of renewed, ecologically pure and cheap energy deposits near to a megalopolis makes it really invaluable. For testing of thermal water resources and development of rational exploitation conditions of Tbilisi deposits we carried out investigations on thermal properties (heat conductivity, thermal gradient, heat flow, temperature) of geological layers using borehole data.

Tectonic faults divide the investigated area into three parts: Lisi-Saburtalo, Central and oil producing area. There were considered 10 boreholes in Lisi-Saburtalo, 20 in Central and 7 boreholes in oil producing area.

Object of geothermal investigations is Middle Eocene water-bearing complex. The main goal is the determination of temperature conditions on the roof and the foot of the aquifer. Initial materials are the thermogram data and thermal characteristics of rocks, measured by the method of impulse flat heat source that has been developed by the authors.

Experimental setup

The method of impulse flat heat source has certain advantages compared to other thermal methods [Lubimova. et al., 1964, Sakvarelidze et al., 1968, Sakvarelidze et al., 1998]. These advantages are:

1. Simple geometry of a sample and its comparatively small size;
2. High degree of contact between heater and sample;
3. Quick response of the heater;
4. Opportunity to measure two identical samples of the same rock simultaneously.

The scheme of experimental device is presented with Fig. 1. The sample, which is being investigated, is a disk or cylinder. The heater is clamped between two identical samples and is made of nichrome wire with diameter 0.05 mm. Diameter of the heater is equal to the diameter of a sample, and is horizontal spiral-shaped (right hand side).

During the current flow through heater a thermal pulse is generated, of which duration is regulated with the help of time relay and usually does not exceed 3-4 s. Temperature alteration in a sample, stimulated by the thermal impulse is registered by a chromel-alumel differential thermocouple; one of its soldered joint is put into a sample, and the second one is taken to the Dewar vessel without ice. Such thermocouple gives an opportunity to record the temperature variation, which results from the thermal impulse. The voltage of the thermocouple is measured either on the mirror

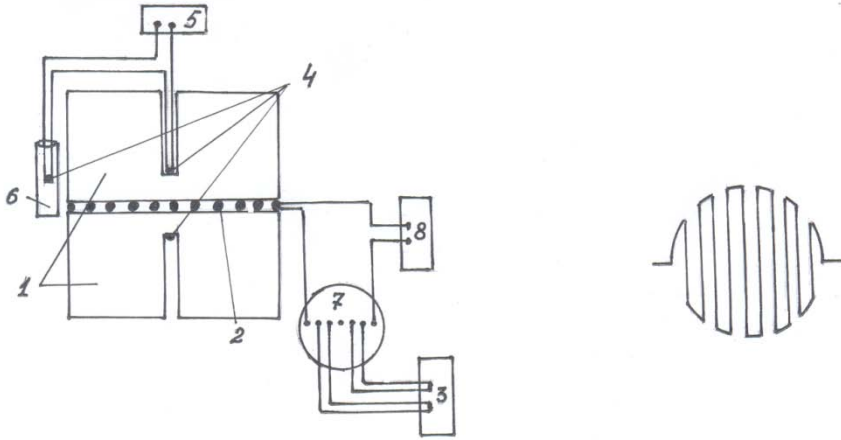

Fig. 1 1 – sample, 2 – heater, 3 - current source, 4 – thermocouple, 5 – temperature recorder, 6 – Duar’s vessel, 7 – wattmeter, 8 - time relay and right hand side the design of the heater.

galvanometer scale M-17/4, which is scaled into degrees, or by potentiometer KСII-4.

During the experiment, the temperature maximum at the measurement point and the time of its attainment are measured. Thermal coefficients are calculated according to formulas:

Thermal diffusivity

$$k = \frac{R^2}{2t_m} \quad (1),$$

Volume heat capacity

$$c\rho = \frac{Q}{4T_m SR} \quad (2),$$

Heat conductivity

$$\lambda = kc\rho \quad (3)$$

with R is distance between the heater and the junction of the thermocouple, T_m is the temperature maximum, t_m is the time to reach the

temperature maximum, Q is quantity of heat released by the heater, S is the heater square area. The maximum relative errors of k , $c\rho$ and λ are correspondingly 1.2 %, 4.3 % and 5.5 %.

It is important to mention that the compactness and simplicity of this equipment and also the short time necessary for the experiment are advantages for its use in investigations within a wide range of temperature and pressure.

The described equipment is also convenient for testing wet rock properties. Rocks at natural conditions are saturated by ground water. The influence of gradually drying of the samples on the laboratory measurements has been studied. For this purpose, all samples were saturated in water during one month. Measurements were performed immediately after taking the sample out of the water. The duration of this experiment was not more than 2-3 minutes. The following measurements were continued after fixed time intervals. The results of experiments are shown at the graphs.

It's evident that maximum values of heat conductivity and thermal diffusivity are observed during the first day, when the samples were fully saturated by water. The values decrease considerably after the first day until the tenth day. After ten days the values decrease slightly and for some samples they remained almost constant. The values of the heat capacity are constant within the experimental error (except for some samples).

Experiments have shown that in order to save natural conditions of samples, it is necessary not only to wax the samples, but also to saturate them.

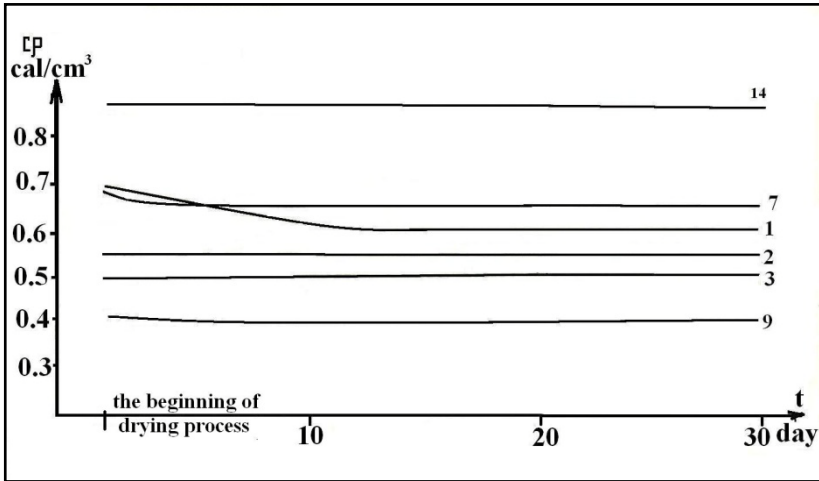

Fig.5. Variation of volume heat capacity

Temperatures distribution at the aquifer interfaces

Temperature gradient values were calculated on the bases of thermogram data. Thermogradient value of the investigated area has been averaged to 0.0249°C/m.

Heat flow values were calculated by the formula (Glonti et al., 2009):

$$q = \lambda \cdot \text{grad}T \quad (4)$$

Average data of the heat conductivity and the heat flow for each layer are given in table 1. The highest values of heat conductivity prevail in the Central area.

Table1

Region	Average value of heat conductivity coefficient (W/m°C)				Average value of heat flow 10^{-3} (W/m ²)
	Oligocene layer	Upper Eocene	Middle Eocene	Low Eocene	

		layer	layer	layer	
Lisi-Saburtalo	1.35	1.68	1.86	1.96	42
Central	-	1.75	1.88	2.09	48
Oil production	1.13	1.44	1.56	1.90	47

Heat flow values are more stable and rather low in comparison with values of the Ajara-Trialeti folded system, which perhaps is connected not only to geotectonic conditions, but also to underground water dynamics.

The calculation of temperatures at aquifer interfaces is based on the formula (Glonti et al., 2009):

$$T_N = T_{N-1} + 1 / \lambda_N \cdot q H_N, \quad (5)$$

where T_N is the temperature at the bottom of the N-th layer, T_{N-1} is that at (N-1)-th layer, λ_N is the heat conductivity of the N-th layer, H_N is its thickness, q is heat flow in the given borehole.

The calculated temperatures of Middle Eocene aquifers are given in table 2.

Region	Average Depth of Middle Eocene (m)		Average Temperature of Middle Eocene (°C)	
	top	bottom	top	bottom
Lisi-Saburtalo	2102	2625	67	83
Central	420	960	16.8	34
Oil prospecting	1300	3730	55	124

On the basis of the measurements and calculations, it can be seen that at the Lisi-Saburtalo region the depth of about 2100 m is promising for high temperature water (~70°C) and water-steam mix (~130°C); in the oil production area they are expected at the depth 3700 m.

References

Lubimova, E., G. Starikova, A. Shushpanov. “Thermo-physical researches of rocks” in the collection “Geothermal researches”, “Science”, 1964

Sakvarelidze, E. “About the research methods of rocks thermal parameters’ dependence of temperature”, Reports, AS GSR, volume 51, issue №1, 1968

Sakvarelidze, E., N. Mamulia “Determination of Rock Heat Conduction Based on the Regular Heat Regime Method in Wide Temperature Range” Bul. Of the Georgian Acad. Of Sciences, 158, № 2, 1998

Glonti L., Sakvarelidze E. Thermal Parameters Comparative Characteristic of Tbilisi Thermal Rocks Waters Deposit’s Three Regions. Institute of Hydrogeology and Engineering Geology Proceedings, vol.XY11, Tbilisi, 2009 p, 59-63

Glonti L., Sakvarelidze E., Melikadze G., Kobzev G. Thermal Parameters and Temperatures Distribution in Water-bearing Complex of Tbilisi Thermal Waters Deposit Central Region. Institute of Hydrogeology and Engineering Geology Proceedings, vol.XY11, Tbilisi, 2009 p. 54-59

METHODOLOGY OF CREATION MULTI-PARAMETRICAL NETWORK

GEORGE I. MELIKADZE, NADEZHDA DOVGAL
Institute of Earth Sciences, Ilia State University

Multi-parametrical monitoring has been carried out on deep boreholes of Georgia. Till now the network of 10 boreholes of different depths (from 300 up to 3500 m) covers the whole territory of Georgia. Boreholes characterize all basic geo-plates and open aquifers of deep circulation. Actually, they represent sensitive volumetric strain-meters. The boreholes response to all deformations between 10^{-7} - 10^{-9} , which are caused by endogenous and exogenous factors. The lower value of deformation limits the sensitivity which is necessary for earthquake preparation processes ($>10^{-7}$).

Special monitoring equipment is installed at boreholes which record several parameters, i.e. water level and micro-temperature, atmosphere pressure and surface temperature, tilt, magnetic field and others. The data can be gathered in real time using the GSM net.

Regular hydrodynamic observation is experimentally established on the territory of Georgia in order to realize the process of preparation of earthquakes by the increase of deformation which causes the underground water to move.

Keywords: Multi-parameters, network.

1. Introduction

Georgia is a part of a big geodynamical active region, known as the Mediterranean Belt, which includes the whole Caucasus and Northern parts of Turkey and Iran. As a result of plate migration, the strong compressive strains are building in the crust. The energy released during sudden stress drop events may trigger the earthquakes.

All over the world and in Georgia also, various anomalies (Hydro-dynamical, hydro-chemical, micro-temperature etc) observed before earthquakes, besides in most cases, on enough distant places from epicentres. Therefore studying the geodynamical processes may help to forecast the natural catastrophes with reasonable probability.

2. Data-analysis

Since 1979, the researches for the forecast of earthquakes promoted development of a hydro-chemical network of special regime regional observation. On the territory of Georgia hydro-chemical observations are carried out on the 23 boreholes (Fig. 1).

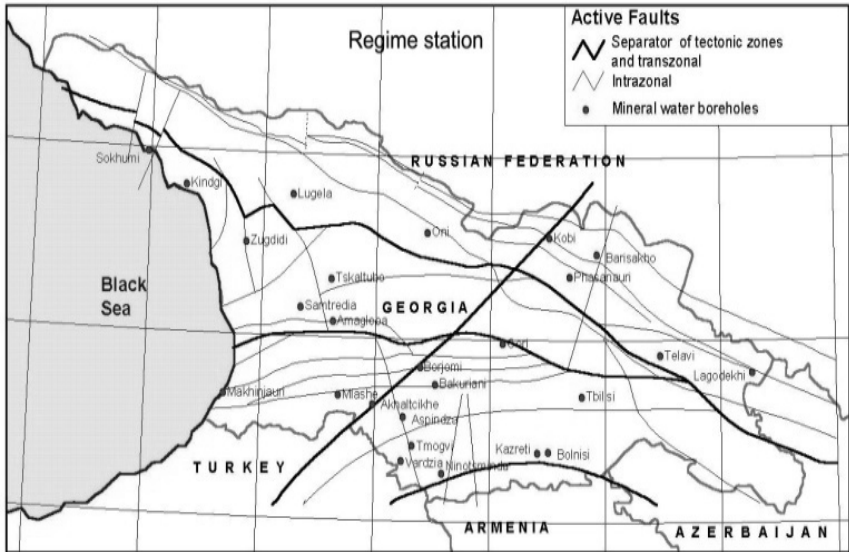

Fig.1. Scheme of hydro-chemical monitoring stations on the territory of Georgia

Measurements of water debit- by volumetric method, temperature of water and air - by mercury thermometer were daily carried out on the water

points. Helium concentration was directly defined on the water points with the same frequency. Chemical composition of water was assessed on 20 components (HCO₃, Cl, SO₄, Na, K, Ca, Mg, J, Br-, Zn, Cu, Fe, Mn, He etc). Water chemical analysis was done by standard methodology.

The only way in the absence of criteria of estimation of information values was to make retrospective analysis on energy of occurred earthquakes (Fig. 2, 3, 4).

During observations a lot of anomalies were fixed, but because of the diversity of chemical water content it was impossible to conduct observations of the unified parameters for creating the complete picture of strains on the whole territory (Melikadze G., Adamchuk Y., et al., 1989).

This is the reason why they decided to conduct observations for those parameters which could fix tidal variations with deformation of 10^{-8} degree, what is compared with strains differences during earthquakes preparation period. Besides it was possible to conduct unified observations. The water level in the deep boreholes was such a parameter (Hsieh et al., 1987, Hsieh et al., 1988).

The modern methods of earthquakes forecast allow watching temporal and spatial changes of strain in the terrestrial crust. One of them is the monitoring method of hydrogeodeformation ground field (HGF). A regime network, according to the development of VSEGINGEO, in Caucasus has been established since 1985. Till now the network of 10 boreholes of different depth (from 250 up to 3500 m) covers the whole territory of Georgia. Boreholes characterize all basic geo-plates and open waters of deep aquifer, actually they represent sensitive volumetric strainmeters, and react on the deformations about 10^{-7} - 10^{-8} , caused both by endogenous, and exogenous factors. A borehole was considered informative if it was fixing tidal variations and was included in the network (Melikadze G. et al., 1989).

They are situated in different tectonic areas. The deep boreholes with undisturbed regime were chosen for the observations which were not influenced by other boreholes.

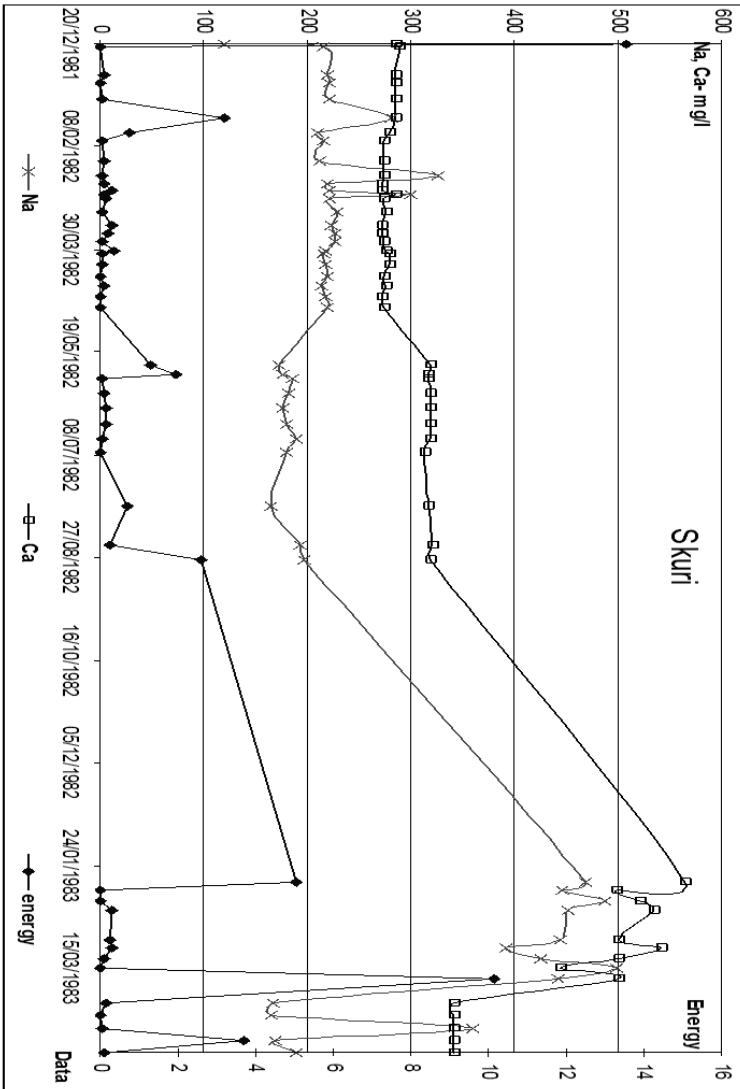

Fig. 2 Variation of hydro-chemical parameters and earthquakes energy at the Skuri station

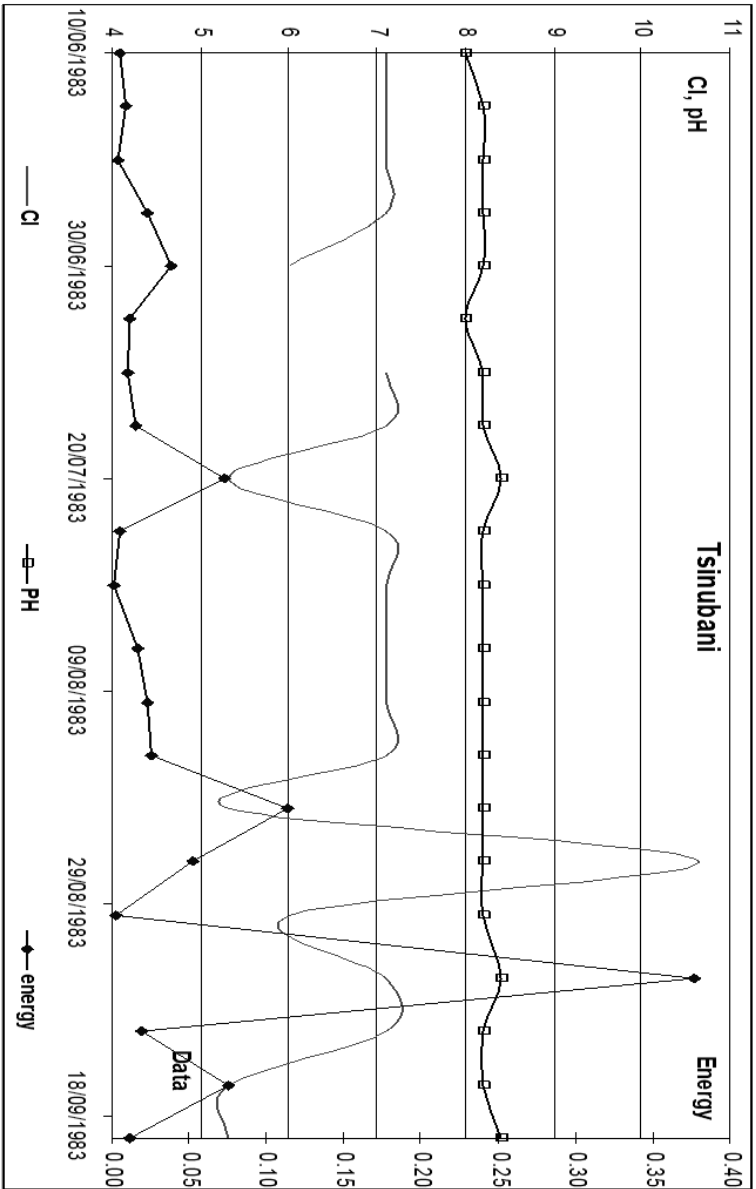

Fig. 3 Variation of hydro-chemical parameters and earthquakes energy on the Tsinubani station

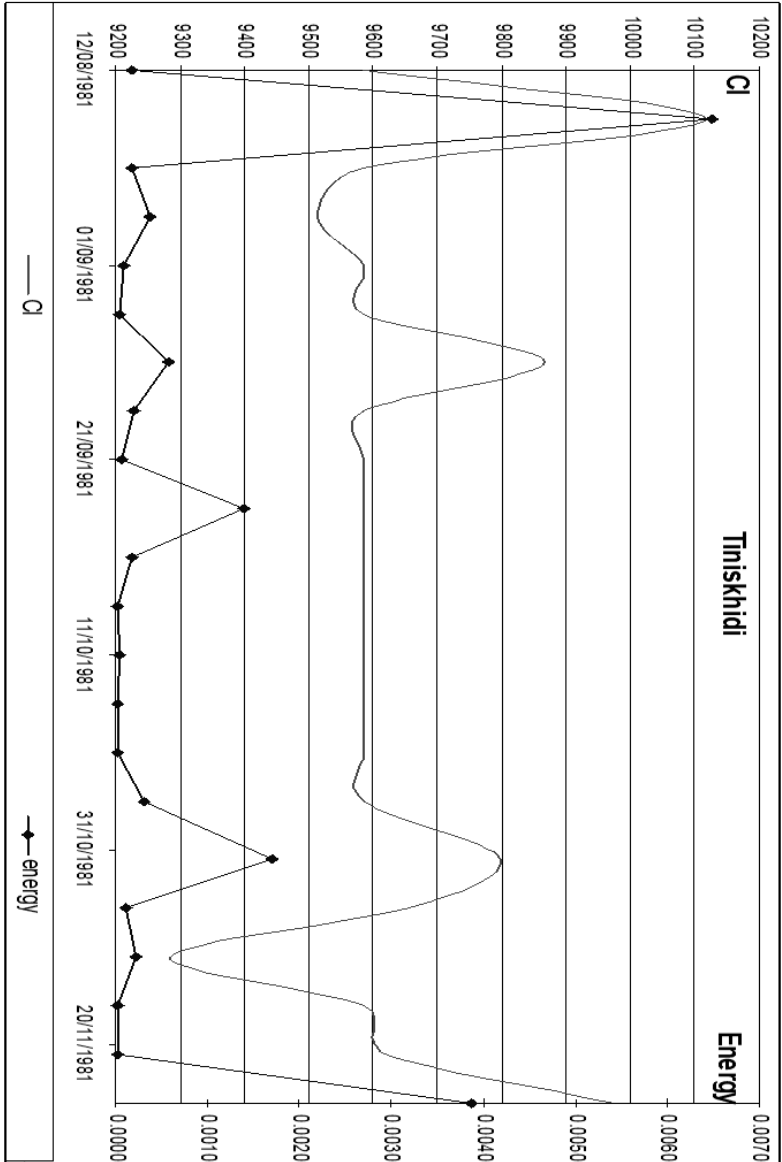

Fig. 4 Variation of hydro-chemical parameters and earthquakes energy on the Timiskhidi station

Boreholes are equally spread all over the territory, basically on main geo-plates. These wells record all kinds of deformation caused by

exogenous (atmospheric pressure, tidal variations and precipitation), as well as endogenous\ tectonic processes (Rojstaczer S. et al., 1998, Melikadze et al., 2002). On some boreholes, reaction of tidal-variation or atmosphere pressure dominated. For example, the atmospheric pressure is dominant at Adjameti and Oni boreholes and then tidal variations. But the tides are dominant on the Marneuli and Lagodekhi boreholes (Melikadze et al, 2004).

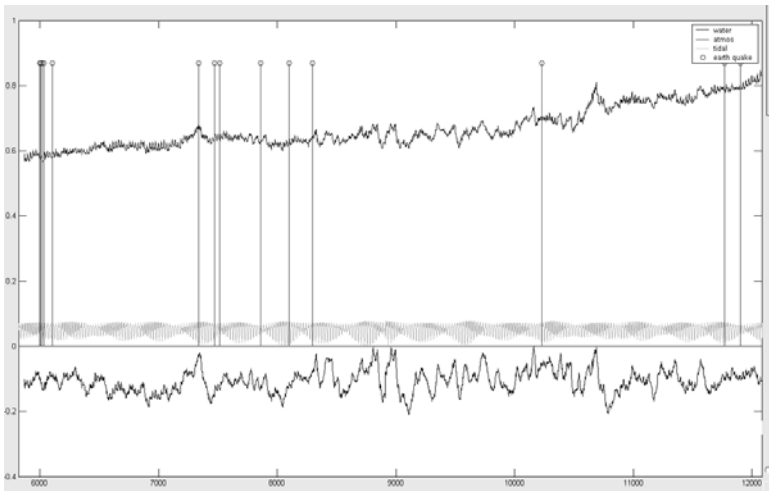

Fig. 5 Variations in time of water level (the bottom line), atmospheric pressure (the top line) and the tides (an average line) in the Adjameti borehole. Vertical lines correspond to the occurrence of earthquakes.

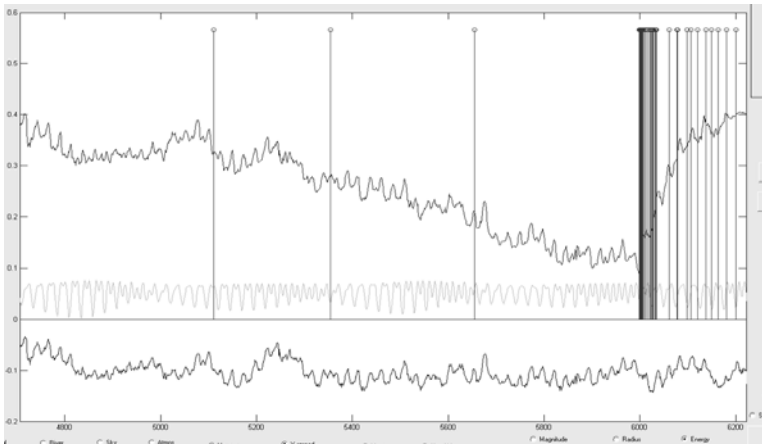

Fig. 6. Variations in time of water level (the bottom line), an atmospheric pressure (the top line) and the tides (an average line) in the Oni borehole. Vertical lines correspond to the occurrence of earthquakes.

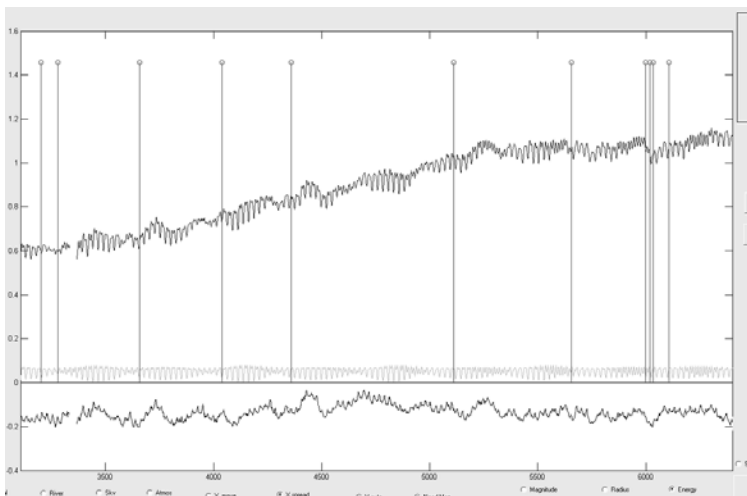

Fig. 7 Variations in time of water level (the bottom line), atmospheric pressure (the top line) and the tides (an average line) in the Marneuli borehole. Vertical lines correspond to the occurrence of earthquakes.

Distinctions in dominating factors are caused by depth of a borehole, its design, originality of a geological and hydro-geological structure water aquifer, value of the gas factor, etc.

For the conductance of qualitative observations appropriate equipment is necessary which could ensure frequent parameters inquiry, data transmission of determined frequency. After searching we have chosen data logger by American production to which 8 analogue ports and one pulse port are attached as well as corresponding sensors of water level or water pressure, atmospheric pressure and temperature.

This equipment ensures attachment of other informative sensors, which were chosen for such observation as magnetic and tiltmeter, Radon and Helium gases. The registration of this data occurs with a frequency of one time in a minute.

The data collection takes place with a frequency of one time in a day or more rarely. The data reception is ensured with the help of software of American data-logger.

All the data is collected in Matlab for the following processing, water level, atmospheric pressure, temperature, tilt-meter, which we get from the boreholes, tidal variations, which we calculate from the special program (GRAV To) and earthquakes data, which we receive from seismic station. In Matlab we calculate the stress condition from the earthquakes data, for each borehole by Dobrovolsky's $\epsilon = 10^{1,3M-8,19/R^3}$ equation.

Conclusion

According to the new methodology, we have selected informatively deep boreholes for the special network, which covers the whole territory of Georgia and characterize all basic geo-plates. They represent sensitive strainmeters and fixed the deformations processes about 10^{-7} - 10^{-8} , caused both by endogenous and exogenous factors.

References

Melikadze G., Adamchuk Y., Todadze M. Search informational harbingers of earthquakes on the territory Georgia. A series Geology «Gruziinti» N10, P.,1989

Hsieh, P. A., I. D. Bredehoeft, I. M. Farr. Determination of Aquifer Transmissivity from Earth Tide Analysis. *Water resources research*. vol. 23. 10. 1987, p.p. 1824-1832.

Hsieh, P. A., I. D. Bredehoeft, S. A. Rojstaczer. Response of Well-Aquifer Systems to Earth Ties: Problems Revisited. *Water resources Research* vol. 24. No. 3. 1988, p.p. 468-472.

Melikadze, G., Popov E. A. Technique of Hydro-geological supervision with the purposes of the forecast earthquake on territory of Georgia. *A series geology «Gruziinti»* N7, 1989.

Rojstaczer, S. 1988. Intermediate period response of water wells to crustal strain: Sensitivity and noise level, *J. Geophys. Res.*, 93, 13,387-12,402.

Melikadze G., Matcharashvili T., Chelidze T., Ghlonti E. Earthquake related disturbance in stationarity of water level variation. *Bulletin of the Academy of sciences of the Georgian*, 165 № 1, 2002

Melikadze G., Buntebarth G., Chelidze T. Hydrodynamic and microtemperature monitoring in seismic areas. *Georgian Engineering News*, # 3, 2004 , p.p 12-132

A METHOD OF HYDROGEODYNAMICAL DATA ANALYSIS FOR REVEALING EARTHQUAKE PRECURSOR

GENADI KOBZEV, GEORGE MELIKADZE
Institute of Earth Sciences, Ilia State University

In order to analyze data series, different methods of mathematical statistics are applied generally. However, all of them have one weak point: after removal of the trend caused by exogenous factors (tidal variation and atmospheric pressure) the applied frequency filters distort the required endogenous signal.

We have developed a new method using computer program MatLab. It enables to synthesize a theoretical signal and compare it with original data of water level. The program enables to characterize each exogenous parameter separately. It allows studying the influence of each of them on the aquifer. It is determined that the aquifers are influenced by all kinds of exogenous factors. The reaction of boreholes demonstrates that one of them can dominate. After processing by suggested method almost identical figures describing the tectonic factor have been received.

Keywords: MatLab program, exogenous factors

1. Introduction

Revealing mechanism of interrelation between the deformation processes, strong earthquakes and hydrodynamics of underground waters would allow explaining precursory behaviour of hydrodynamic field and developing scientifically well grounded methods of earthquakes' forecast. At the analysis of materials, scientists individually selected methods of mathematical statistics, but all of them had one thing in common: after removal of the trend caused by exogenous factors (tidal variation and atmospheric pressure) they used frequency filters (P. A. Hsieh et al., 1987,

1988), that in our opinion distort the required endogenous signal. The residual values were analyzed for revealing correlation of water level variations with seismic events.

Our method, which uses the computer program MatLab, created exogenous theoretical signal and compare it with real signal. In comparison with the last, the method enables to characterize every exogenous parameter separately. That makes possible to study influence of each of them on the water aquifer.

2. Data analysis

The following factors influence the aquifer and changes in water level: tides, atmospheric pressure, precipitation, tectonic-seismic factors, the error from apparatus and so on. Let us represent the summary signal using linear equation:

$$\text{Water level} = a*\text{tidal} + b*\text{atmos} + c*\text{precip} + e;$$

with a - coefficient for tidal variation, b - atmosphere pressure, c - precipitation, and e - geodynamical signal.

Water level and atmospheric pressure are measured directly at boreholes. Theoretical data for tidal variations are generated by the program GRAV. To determine the stress conditions in the aquifer after strong earthquake, Dobrovolsky's $e = 10^{1.3M-8.19/R^3}$ equation has been applied. In the catalog, we select earthquakes, which are strong enough to affect boreholes' sites (Fig. 1).

Research workshop on Exploration and Exploitation of Groundwater and Thermal Water Systems in Georgia

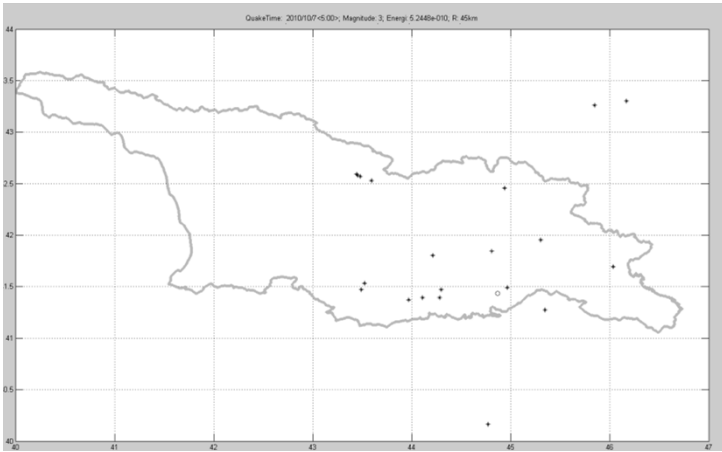

Fig. 1 Earthquakes, which were selected by energy, distance or magnitude

We can also select earthquakes by magnitude and distance from the borehole. So, for example, there is observed an evident correlation of underground water level changes with tidal variations for “Marneuli” borehole.

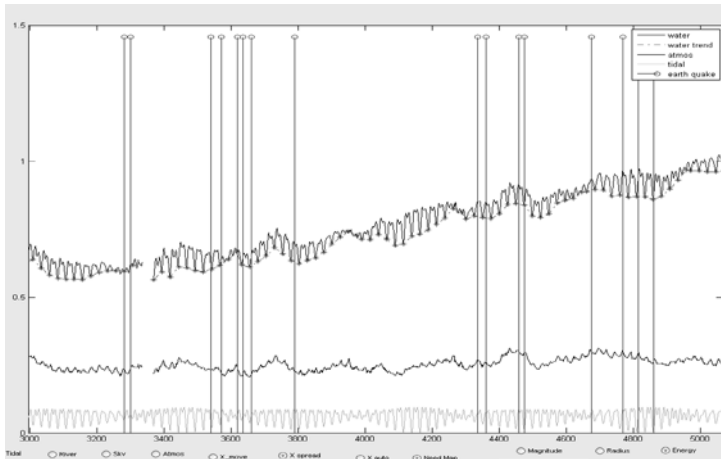

Fig. 2. Water level, tidal variation, atmosphere pressure and earthquakes at Marneuli station Upper line is water level, lower line is tidal variation, middle line is atmospheric pressure. Vertical lines indicate earthquakes.

Program finds minimum time-points of tidal variation and compare it with water level variation value's point at the same time. By connection of these points we receive some "trends" of both parameters. After extracting this "trend" from the original data, we receive "residual" values of water level variation.

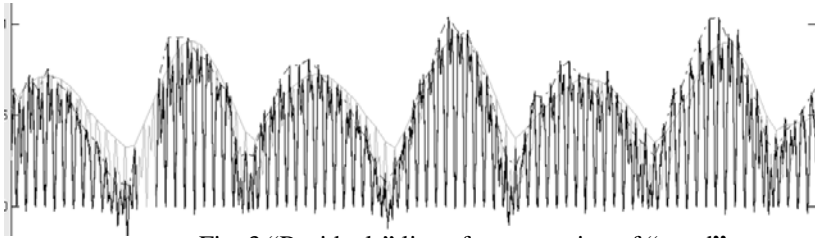

Fig. 3 "Residuals" line after extraction of "trend"

Program calculated such type of "residual" values for atmosphere pressure, too. Program allows extracting different influence of tidal-variation, atmosphere pressure and both totally.

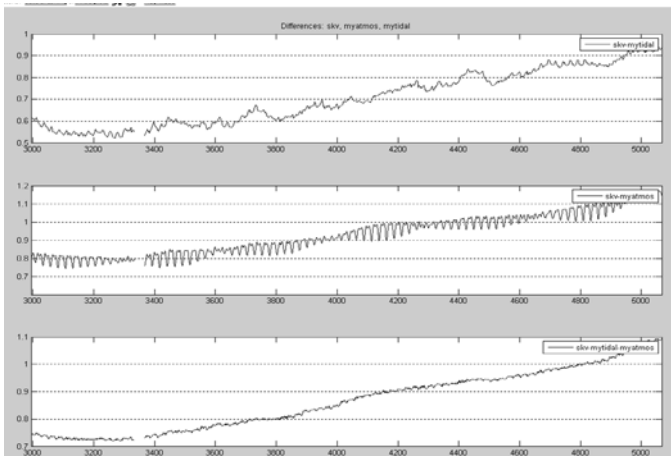

Fig. 4. Water level variation after extraction of tidal variation (upper line), atmosphere pressure (middle line) and of both parameters (lower line).

This program allows also calculating time shift between extremes of tidal-variation and water level, which tells us about how the aquifer is stressed.

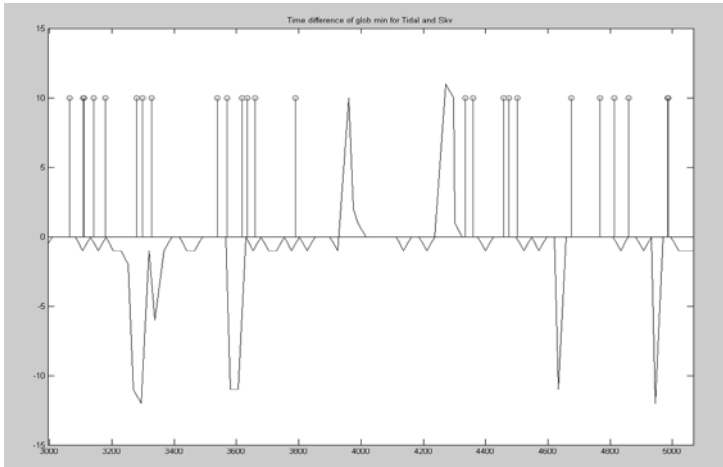

Fig. 5. Time-shift difference between extremes of water level and tidal variation (broken line). Vertical strait lines indicate earthquakes.

Results have shown changes in stress–sensitivity and deterioration of reaction of aquifer to tidal variations before and during the period of seismic event that demonstrates the value of water level variation as an indicator of tectonic activity.

For automatic finding of disturbances of environment’s equilibrium condition in relation to the exogenous factors, caused by imposing an additional endogenous component (Melikadze G. at al., 1989, 2002), special program had been developed, allowing finding components of this equation.

$$water\ level(x)=a*tidal(x)+b*atmosphere(x)+c.$$

During monitoring, we measure water level, tidal variation and atmospheric pressure. In order to find coefficients a , b , c it is necessary to write a system of 3 (or more) equations. MatLab allows working with over-determined systems and the whole time interval will be split on many intervals (for example on 24 hour’s intervals). For every interval the program finds a set of coefficients. During calculations the following

equation are solved, where $W(x)$ is water level variation, $T(x)$ is tidal variation; $A(x)$ is atmospheric pressure, c is constant. Program use measured values of W, A, T at the moment x_i for system of equations

$$\left\{ \begin{array}{l} W(x_1)=a*T(x_1)+b*A(x_1)+c \\ W(x_2)=a*T(x_2)+b*A(x_2)+c \\ W(x_3)=a*T(x_3)+b*A(x_3)+c \end{array} \right.$$

or in the matrix form $W=M*X$, where

$$W = \left\{ \begin{array}{l} W(x_1) \\ W(x_2) \\ W(x_3) \\ \dots \end{array} \right\} \quad M = \left\{ \begin{array}{lll} T(x_1) & A(x_1) & 1 \\ T(x_2) & A(x_2) & 1 \\ T(x_3) & A(x_3) & 1 \end{array} \right\} \quad X = \left\{ \begin{array}{l} a \\ b \end{array} \right\}$$

After calculation, program demonstrates time-dependence of coefficient a , which depends on water level and tidal variation, b , which depends on water level and atmosphere pressure and distribution of constant coefficient c (Fig. 6).

Research workshop on Exploration and Exploitation of Groundwater and Thermal Water Systems in Georgia

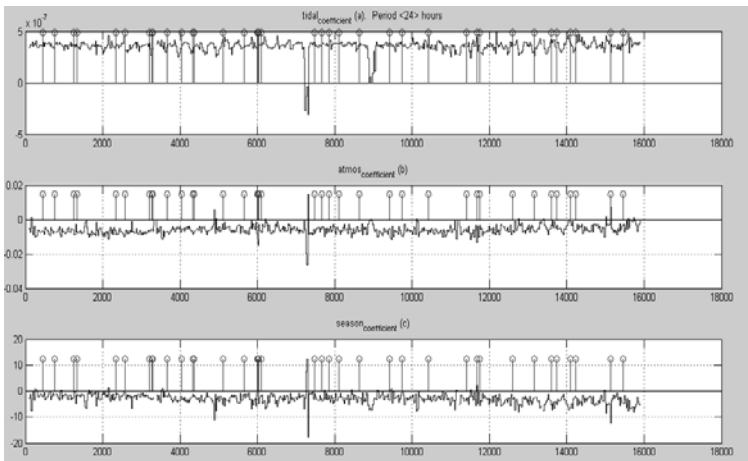

Fig. 6. Variation of coefficients (broken line). Vertical straight lines indicate earthquakes.

Furthermore, c of all coefficients is done (Fig. 7).

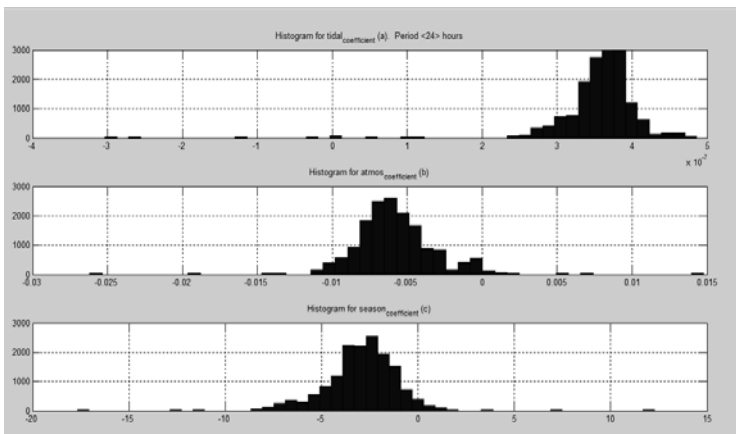

Fig. 7. Spectral graphics of a, b, c coefficient.

Program calculates “summary” signal (Fig. 8), which demonstrate reliability and relation of anomalies for all coefficients.

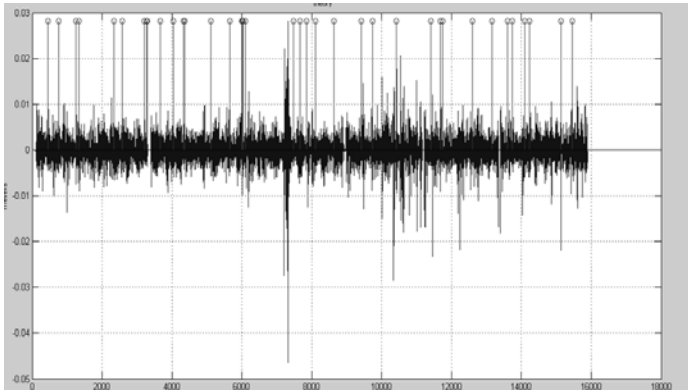

Fig. 8. Variation of “summery” signal (broken line). Vertical strait lines indicate earthquakes.

After extraction of high the frecency signal, program derives the trend signal from the water level value.

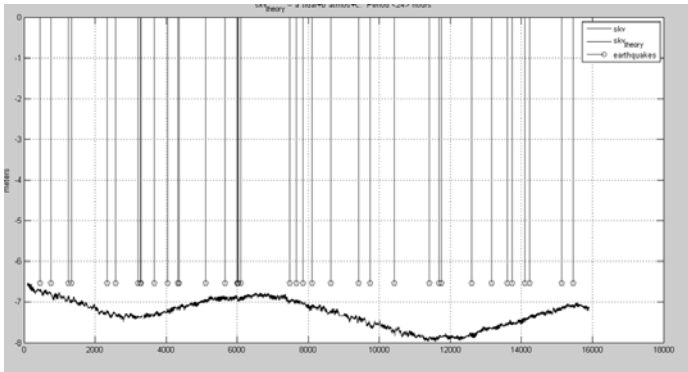

Fig. 9. Variation of trend signal in the Marneuli borehole. Vertical strait lines indicate earthquakes.

Results of data analysis have shown deterioration of reaction of coefficients a , b , c before and during seismic event that demonstrates the value of water level variation as an indicator of tectonic activity.

Conclusion

Water level variation basically is caused by the atmospheric pressure and earth crust tidal variations, as well as the “background” values, which change during earthquake preparation period. Amplitude and period of a , b , c coefficients changed by energy of earthquakes.

References

- Hsieh, P. A., I. D. Bredehoeft, I. M. Farr.** Determination of Aquifer Transmissivity from Earth Tide Analysis. *Water resources research*, vol. 23, 10, 1987, 1824-1832.
- Hsieh, P. A., I. D. Bredehoeft, S. A. Rojstaczer.** Response of Well-Aquifer Systems to Earth Tides: Problems Revisited. *Water resources research* vol. 24, No. 3, 1988, 468-472.
- Melikadze, G., Popov, E.** A technique of Hydro-geological supervision with the purposes of the forecast earthquake on territory of Georgia. *A series geology «Gruziinti»* N7, 1989.
- Melikadze, G., Matcharashvili, T., Chelidze, T., Ghlonti, E.** Earthquake related disturbance in stationarity of water level variation. *Bulletin of the Academy of Sciences of Georgia*, 165 № 1, 2002

GEODYNAMICAL IMPACTS ON THE WATER LEVEL VARIATIONS IN BOREHOLES

**TAMAR J. JIMSHELADZE, GEORGE I. MELIKADZE,
GENADI KOBZEV**

Institute of Earth Sciences, Ilia State University

NATALIA ZHUKOVA

Mikheil Nodia Institute of Geophysics

It is known that variations of water level represents itself an integrated response of aquifer to different periodic as well as non periodic influences, including earthquake related strain generation in the earth crust. Quantitative analysis of impacts of separate components in observed integral dynamics remains one of the main geophysical problems. It is especially important for non periodic processes related to the earthquake generation, taking into account their possible prognostic value.

In the present study the dynamical complexity of water level variations has been analyzed. Dependence of dynamics on the presence of periodic components in considered data records (time series) was investigated. Modern tools of time series analysis have been used.

We present results of the analysis of the data of observations by a special program. The results illustrate that correlative dependence between tidal variations and water level changes is breached several days before the earthquake, both in the amplitude and the frequency spectrum.

Keywords: Geodynamical impact, periodic components

1. Introduction

Multi-parametrical monitoring (water level and micro-temperature, atmosphere pressure and air temperature) has been carried out on 10 deep boreholes of Georgia. Special monitoring equipment is installed at boreholes which record all deformations between 10^{-7} - 10^{-9} which are caused by endogenous and exogenous factors. The lower value of deformation limits the sensitivity ($>10^{-7}$) which is fixed during earthquake preparation processes.

In order to analyze data series, we developed a new method in the computer program MatLab. It enables to synthesize a theoretical signal and compare it with original data of a water level. The program allows studying the influence of exogenous and endogenous factors on the aquifer. The reaction of boreholes demonstrates that one of these factors can dominate. Furthermore, from all earthquakes we can select earthquakes, energy of which reaches territory of boreholes using Dobrovolsky's equation (Dobrovolsky et al., 1979). After processing, program is extracting the “geodynamical trend” and “residual” values of high frequency signal from the original data of the water level variation.

Program demonstrates time-dependence of coefficients in correlation equation: a depends on water level and tidal variation, b on water level and atmosphere pressure, c is a constant coefficient. After calculation of coefficients, the program allows carrying out statistical analysis between periods and amplitudes of coefficients with seismic event. The result demonstrates informatively that the water level is an indicator of tectonic activity.

2. Data analysis

For example, the article demonstrates variation of parameters during preparation “Racha” earthquakes of 12.08.2009 ($M= 4$) and in 9.09.2009 ($M= 4.6$) in the tree boreholes. First of them “Oni” is located in the epicentral areas, the second one, “Adjameti”, is 100 km far to South-West direction and finally “Lagodekhi” is 200 km far to East direction from the epicentre.

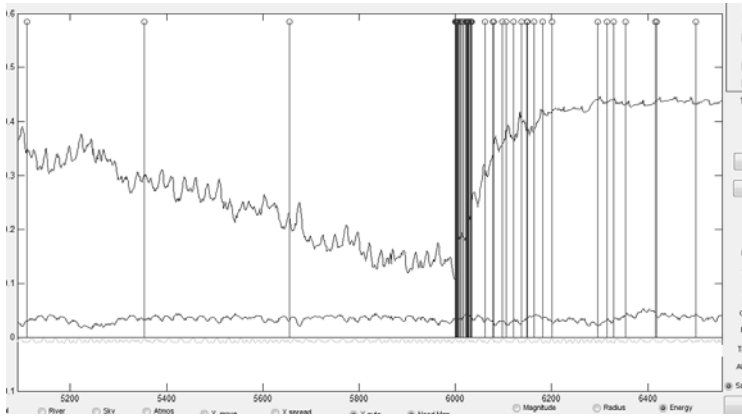

Fig. 1. Variation of water level (upper curve), atmosphere pressure (middle curve) and tidal variation (lower curve) at the “Oni” station. The vertical lines mark earthquakes.

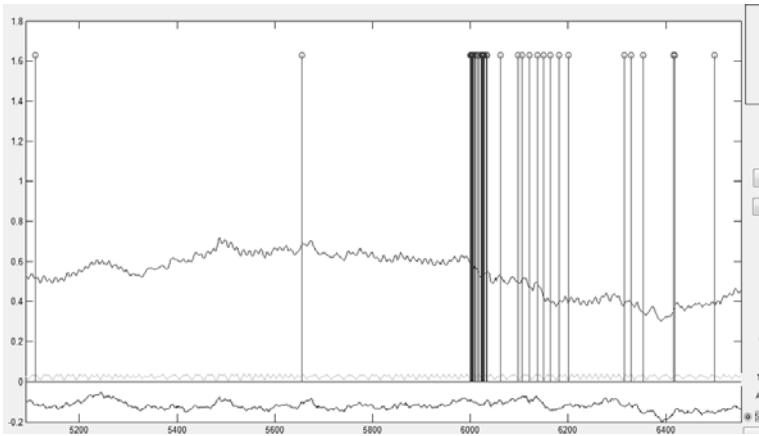

Fig. 2. Variation of water level (upper curve), atmosphere pressure (lower curve) and tidal variation (middle curve) on the “Ajameti” station. The vertical lines mark earthquakes.

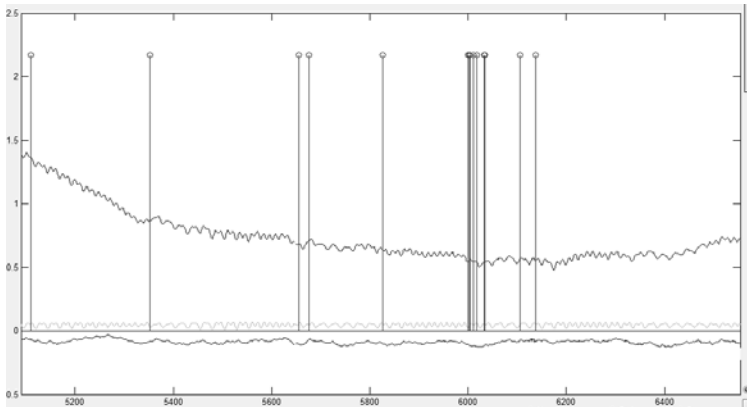

Fig. 3. Variation of water level (upper curve), atmosphere pressure (lower curve) and tidal variation (middle curve) on the “Lagodekhi” station. The vertical lines mark earthquake.

The pictures show the variation of different fields on the stations. Water level variation as a multi-signal value contains all exogenous (tidal variation, atmosphere pressure and precipitation) and endogenous (earthquakes) factors' influence. In the seismically passive period the background of variation reflects only exogenous factors, but during earthquake preparation process the character of variation changed (Bella, Biagi P. et al., 1992, Hsieh et al., 1988). In this period are recorded disturbances in the water level variation before and after of earthquakes (Fig. 1-3).

In order to calculate the “geodynamical signal” special program extracts each exogenous factor from the multi-signal separately (Fig. 4-6).

Research workshop on Exploration and Exploitation of Groundwater and Thermal Water Systems in Georgia

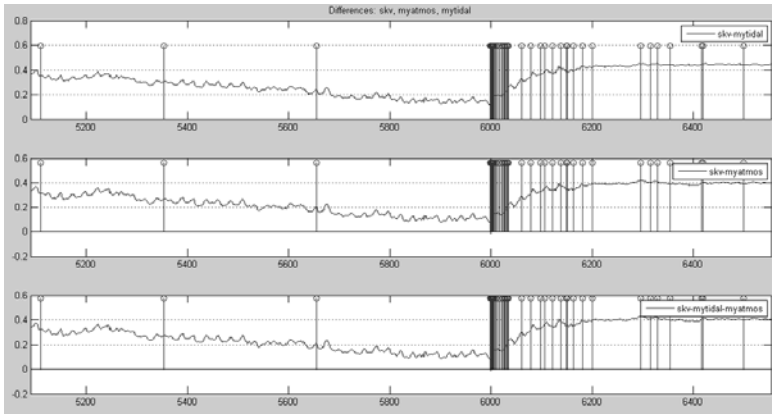

Fig. 4. Extraction of exogenous factor from the multi-signal of “Oni” station. Multi-signal without tidal variation (upper curve), without atmosphere pressure (middle curve) and without both parameters (lower curve). The vertical lines mark earthquake.

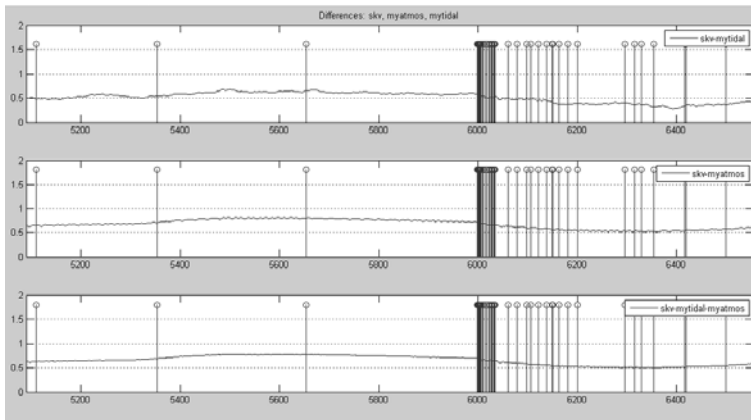

Fig. 5. Extraction of exogenous factor from the multi-signal of “Adjameti” station. Positions of curves are similar to Fig. 4.

Research workshop on Exploration and Exploitation of Groundwater and Thermal Water Systems in Georgia

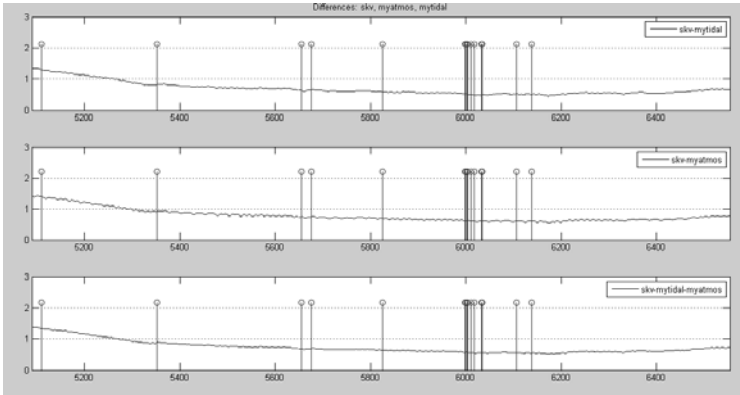

Fig. 6. Extraction of exogenous factor from the multi-signal of “Lagodekhi” station. Positions of curves are similar to Fig. 4.

Furthermore, the program calculates variation of “geodynamical” signal - difference between the water level’s theoretical and observed values and “residual” values of high frequency signal in the water level variation. (Fig. 7-9).

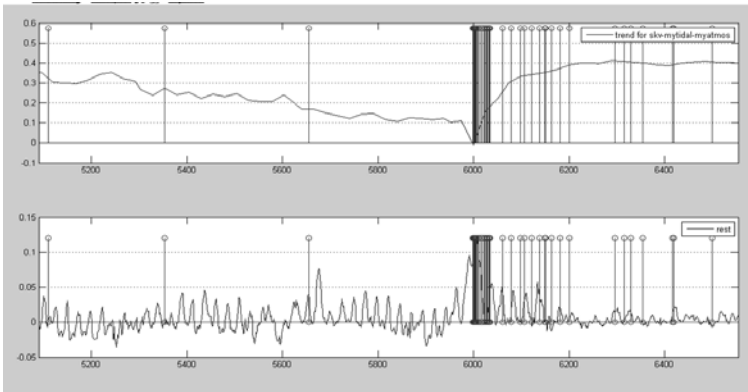

Fig. 7. Variation of “trend” value of geodynamical signal (upper curve) and “residual” (lower curve) at “Oni” station. The vertical lines mark earthquake.

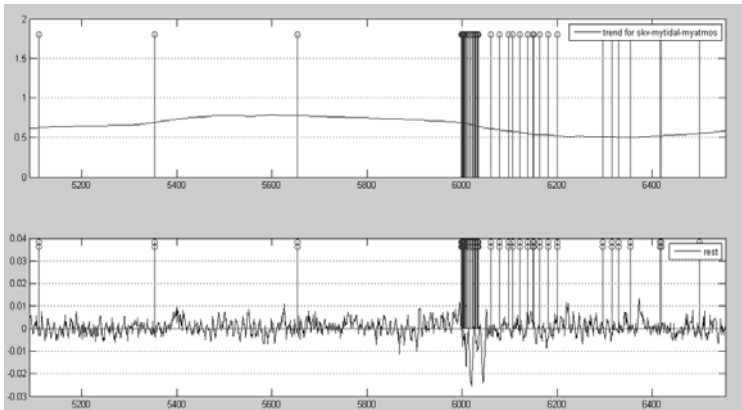

Fig. 8. Variation of “trend” value of geodynamical signal (upper curve) and “residual” (lower curve) at “Adjameti” station. The vertical lines mark earthquake.

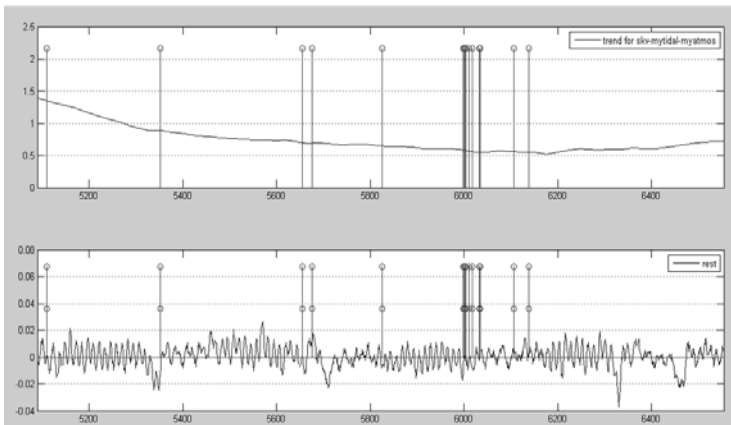

Fig. 9. Variation of “trend” value of geodynamical signal (upper curve) and “residual” (lower curve) at “Lagodekhi” station. The vertical lines mark earthquake.

The drawdown of water level in the “Oni” and “Lagodekhi” boreholes and increase of the “Adjameti” boreholes are fixed. The first effect is characterizing decompression and the second one - compression of aquifer

system before Racha earthquakes. After considered events water level in the “Adjameti” borehole goes down, this characterizes decompression processes. “Oni” station kept compression processes.

In the “residual” lines, the high frequency signal shows changes of period values of variation before and after earthquake events.

In order to calculate statistic dependence between disturbances in coefficients a , b , c and other parameters and to relate it to energy reaching boreholes areas from the epicenter zone, a special statistical program has been written. “Background” values of coefficients a , b , c and summary signal before earthquakes events on both stations are shown in Figs. 10-15.

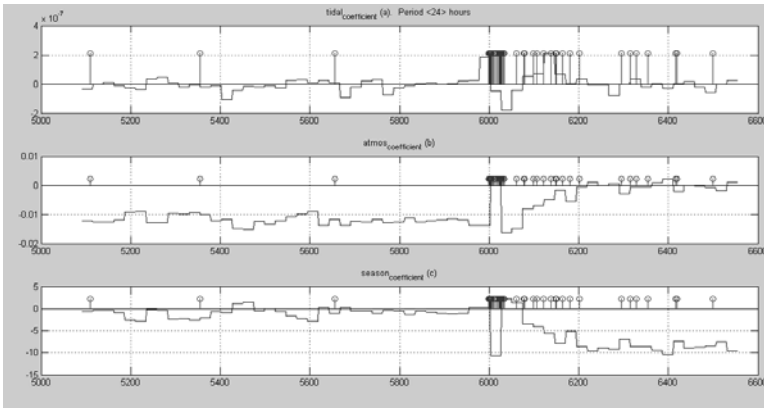

Fig. 10. Variation of a , b and c coefficients at the “Oni” station. The vertical lines mark earthquake.

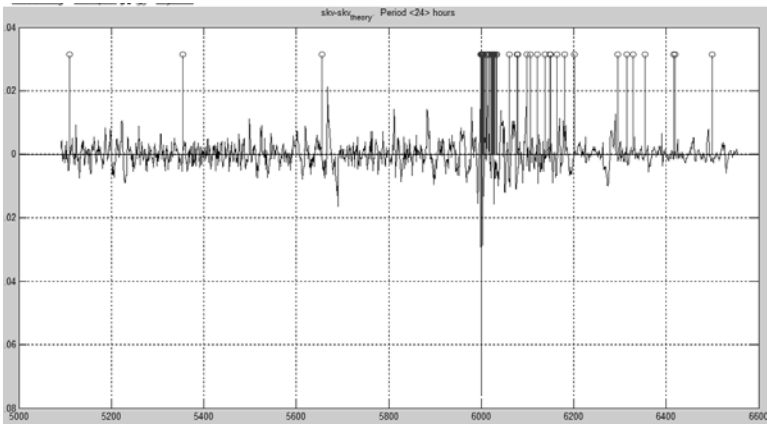

Fig. 11. Variation of “join” signal at the “Oni” station. The vertical lines mark earthquake. The vertical lines mark earthquake.

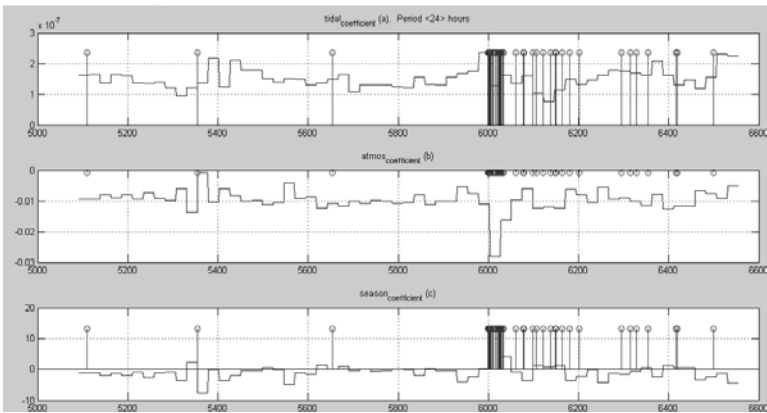

Fig. 12. Variation of a, b and c coefficients at the “Adjameti” station. The vertical lines mark earthquake. The vertical lines mark earthquake.

Research workshop on Exploration and Exploitation of Groundwater and Thermal Water Systems in Georgia

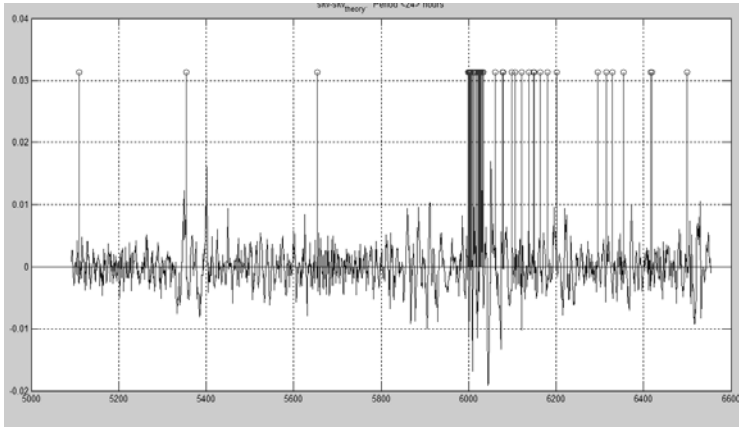

Fig. 13. Variation of "summary" coefficients at the "Adjameti" station. The vertical lines mark earthquake.

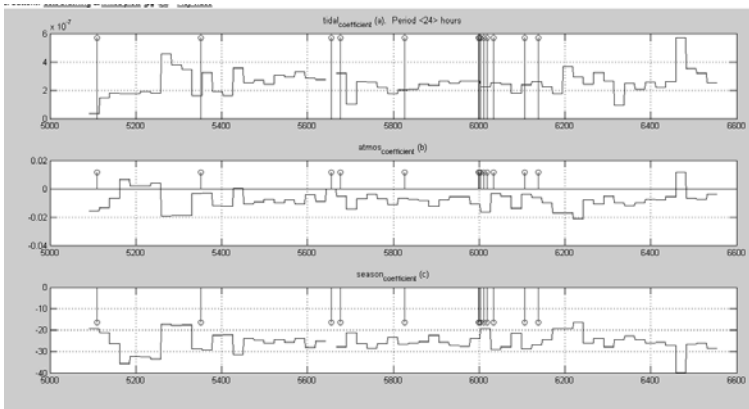

Fig. 14. Variation of a, b and c coefficients at the "Lagodekhi" station. The vertical lines mark earthquake.

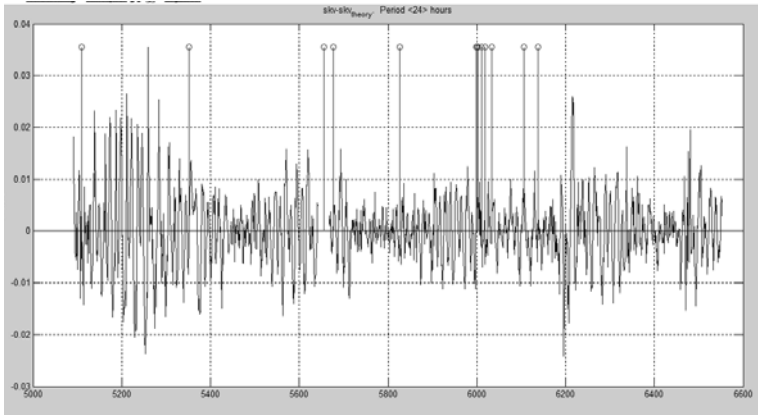

Fig. 15. Variation of "summary" coefficients at the "Lagodekhi" station. The vertical lines mark earthquake.

The "background" values of water level variation was changing before and after events (Melikadze et al., 1989). Character of variation of coefficients for each borehole depends on the energy value, which reached boreholes area. "Lagodekhi" borehole is sensitive for local earthquakes then for "Racha" earthquake. At the same time the amplitude of variation before "Racha" earthquake is stronger in the "Adjameti" station. This can be explained by larger strain-sensitivity of "Adjameti" station (Melikadze et al., 2002).

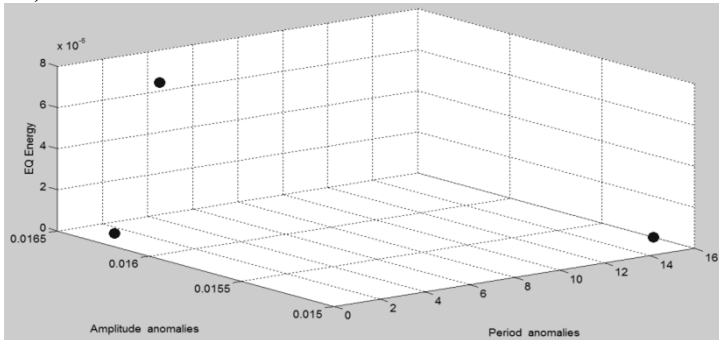

Fig. 16. Dependence between amplitudes and periods of anomalies and earthquakes energy in the "Oni" station

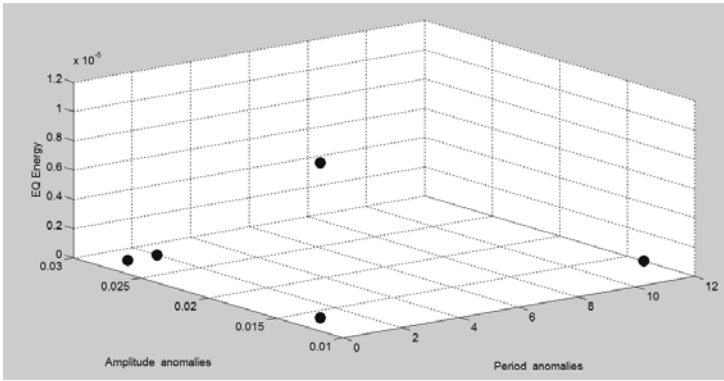

Fig. 17. Dependence amplitudes and periods of anomalies and earthquakes energy in the “Adjameti” station

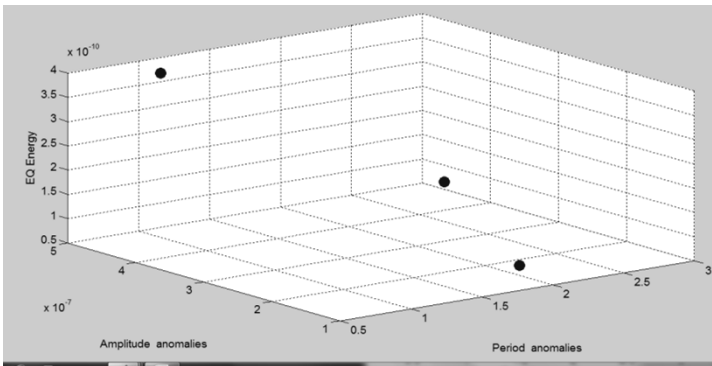

Fig. 18. Dependence between amplitudes and periods of anomalies and earthquakes energy in the “Adjameti” station

A special program is calculating the dependence between earthquakes energy and characteristic of anomalies (amplitudes and periods of anomalies (Figs. 16-18).

Figs. 16-18 show that the main amplitudes of anomaly in the “Oni” station are located between 0.016- 0.0165 and fixed during 4 days. For “Adjameti” station the main amplitudes of anomaly are located between 0.025- 0.03 and generally fixed during 2 days. For “Lagodekhi” station the

main amplitudes of anomaly are located between 2-4 and generally fixed during 3 days. In the “Lagodekhi” and “Adjameti” stations the period of anomaly is less than in the “Oni” station, because they are located far from the epicenter.

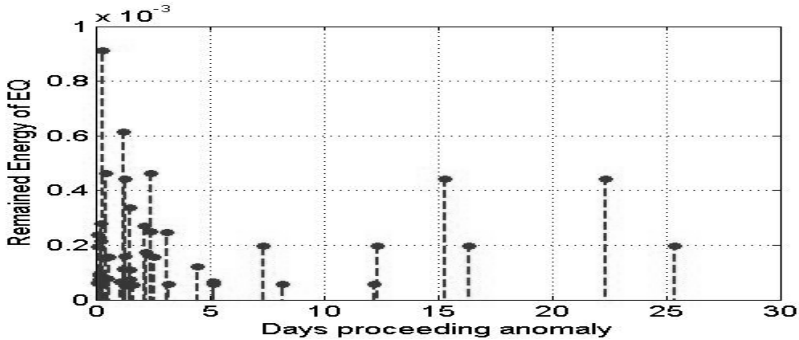

Fig.19. Dependence between the duration of anomaly (in days) and energy of earthquakes in the “Adjameti” station

On Fig. 19 is shown the dependence between the duration of anomaly (in days) and energy of earthquakes at the “Adjameti” station. High energy is registered in the first 5 days’ period of anomaly.

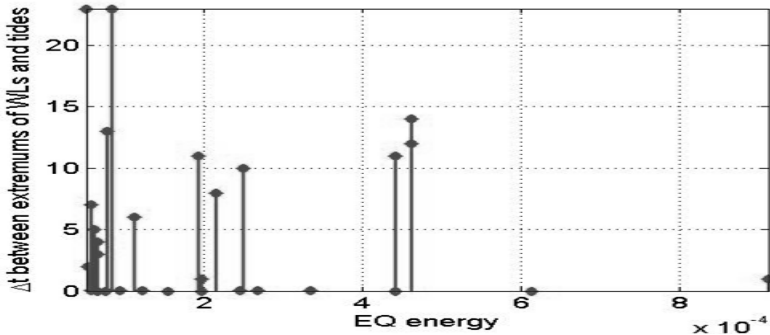

Fig. 20. Dependence of time-shift between extrema of water levels and tides on the energy of earthquakes at the “Adjameti” station.

Fig. 20 shows the correlation between time-shift (the lag) between extrema of water levels and tides on earthquakes energy. Generally, time-shift period increase accordingly of energy.

Conclusions

The information content of hydrodynamic boreholes from the earthquake prognostics point of view was ascertained. The recorded anomalies coincide with the preparation period for strong earthquakes. Characteristics of anomalies (amplitude, period, etc) are correlated with earthquake strength. However, in certain cases, high levels of anomalies are recorded in boreholes located relatively far from the epicentre. In order to explain this, the strain-sensitivity of each borehole should be studied, as well as distribution of strain field on the area and its geological characteristics.

References

- Dobrovolsky, I. P., Zubkov, S. I., and Myachkin, V. I.**, Estimation of the size of earthquake preparation zones, Modeling of earthquake preparation. – Moscow. Nauka, 1979
- Bella F., Biagi P., Melikadze G.** et al. - Anomalies in geophysical and geochemical parameters revealed on the occasion of the Paravani (M=5.6) and Spitak (M=6.9) earthquakes (Caucasus). Amsterdam, Tectonophysics 202 Elsevier Science Publishers B. V.,1992, p.p. 23-41
- Hsieh, P. A., I. D. Bredehoeft, S. A. Rojstaczer.** Response of Well-Aquifer Systems to Earth Ties: Problems Revisited. Water resources research vol. 24. No. 3. 1988, 468-472.
- Melikadze, G., Popov, E.** A technique of Hydro-geological supervision with the purposes of the forecast earthquake on territory of Georgia. A series geology «Gruziinti» N7, 1989.
- Melikadze, G., Matcharashvili, T., Chelidze, T., Ghlonti, E.** Earthquake related disturbance in stationarity of water level variation. Bulletin of the Academy of Sciences of Georgia, 165 № 1, 2002

INDUCED SEISMICITY DUE TO THE OIL PRODUCTION IN TBILISI REGION, GEORGIA

TAMAZ CHELIDZE

Mikheil Nodia Institute of Geophysics

TAMAR J. JIMSHELADZE, GEORGE I. MELIKADZE

Institute of Earth Sciences, Ilia State University

Introduction

30 km to the north-east from the Tbilisi hydrothermal field (THF) the oil field has been revealed. The intensive oil production in 80-s disturbs the regime of the central hydrothermal deposit and causes depletion and desalination of springs. Later on, after cessation of intensive extraction, the regime of hydrothermal field was recovered. These facts point to the significant change of pore pressure conditions during oil production process and triggered an idea to analyze the seismic activity in the period of oil production. As it is well known that the pore pressure change may provoke changes in the seismic activity (Gupta and Rastogi, 1976, Grasso and Sornette, 1998) the attempt is made to assess seismic effects induced by the oil production in the THF.

Geological and hydro-geological setting

The deposits of Lower-Eocene and Paleocene are widely presented in the Tbilisi region. They are composed of the granular sandstones, limestones and marls. The rocks are fractured intensively. This circumstance promotes formation of underground water basins in these deposits. The waters are of sulphite–hydrocarbonate–chloride–natrium-sulphite-natrium-potassium types. Total mineralization varies from 0.2 – 0.5 g/l to 4.4 g/l and increases from West to East.

The volcanic Middle Eocene deposits are the basic horizons of Trialeti and Teleti mountain ridge. They are represented by tuff sandstones, conglomerates, breccias and are characterized by intensive jointing; the

joins mainly are open, which promotes free circulation of underground waters. Total thickness of Middle Eocene deposits is 500–800 m. Waters are of hydrocarbonate-sodium calcium-natrium, hydrocarbonate-chloride-sodium calcium-magnesium type. Total mineralization of waters fluctuates from 0.3 g/l to 1 g/l. Waters in these springs are of high temperature 40-50° C.

Upper Eocene deposits are developed to the East of Tbilisi; they are composed mainly by clayey rocks with streaks of weak white sandstones. These rocks are water resistant. Total thickness of them reaches 1300 m.

It is evident that the main water-bearing complexes of thermal waters are Middle Eocene volcanic formations, located under Lower Eocene–Paleocene flysch deposits, opened by boreholes in Lisi and central section as well as by the productive oil boreholes in the Eastern part of tested area.

From the North, South and East the region is delineated by deep faults and one fault crosses the center of the city, following the valley of river Mtkvari.

Induced seismicity

We begin with considering the man-made effect of intensive oil production near THF that allow to judge about interconnections between oil field and Central thermal field. The effect of intensive oil pumping in the Samgori-Ninotsminda oil field on the water level (WL) in Botanical Garden borehole was the drastic change of pore pressure in the region, namely, in the water debit of the Botanical Garden well (1BG) located on the distance of 30 km from the production area.

According to (Grasso and Sornette, 1998) unloading of the earth's upper crust by hydrocarbon extraction of the order of magnitude of 10^{11} kg may trigger thrust events in a compressive setting 0.07 MPa. In Tbilisi region during 1970-1989 more than $5 \cdot 10^{10}$ to kg of oil was produced so the level of extraction is close to critical. The stress change induced by hydrocarbon extraction is as a rule small, but according to data the deviatoric stress exceeding 0.01 MPa may trigger seismic activity. We calculated the order of stress change according to expression (Grasso and Sornette, 1998)

$$\Delta\sigma_{\max}=[1-2\nu/2\pi]pF_{\max}(a/D)$$

and obtained $\Delta\sigma \approx 0.06$ Mpa, which is enough to induce seismic activity. In order to distinguish the seismohydraulic effect we plotted the seismic activity (SA) versus time in the time interval, covering periods before (1960-1970), during (1970-1989) and after termination (1990-2004) of oil production interval (Fig. 1). To exclude the effect of local seismic network changes during 1960-2004, only the catalog of the Tbilisi Seismic Observatory (TSO), where the registration conditions were not changed in this period has been used. In the analyzed catalog were included events occurred within circular area of radius 50 km around TSO. Three types of TSO catalog were analyzed: TSO1 included all events, recorded at the observatory, even smallest ones; TSO2 included only the events of magnitude $M \geq 2.5$; TSO3 included the events of magnitude $M < 2.5$ and TSO4 is the catalog of explosions, compiled by the Seismic Monitoring Centre of Georgia. According to the catalog TSO1 the SA increase in the hydrocarbon production period is evident.

At the same time there was a danger of contamination of data by some artifacts, for example by explosions which are common in the industrial area. Fig. 2 a, b shows that indeed the annual distribution of total explosion activity has a maximum in 1974-1988 years and the diurnal distribution – at 12 h G.M.T. At the same time the diurnal EQ distribution is quite different for different years of the period 1963-2005 (Fig. 3).

The distributions reveal very interesting details of local seismicity. Histograms from 1960 till 1966 show almost random diurnal distribution of earthquakes (EQs). Beginning from 1966 some maximum of activity begins to appear at 12 hours by G.M.T. (8 hours by local time); in the interval 1973-1991 the maximum is very sharp and the majority of EQ occur in this time of day. From 1992 till the present day the unimodal distribution disappears and the distribution became random again. The dynamics of seismicity distribution can be explained by increase of industrial activity, in this case of the number of explosions from 1973 to 1991, because the explosions mostly were executed at 12 hours by G.M.T or at 8 h of local time (Fig. 3). Since 1991 due to political turmoil the industrial activity in Georgia including explosions was practically terminated (Fig.2).

Research workshop on Exploration and Exploitation of Groundwater and Thermal Water Systems in Georgia

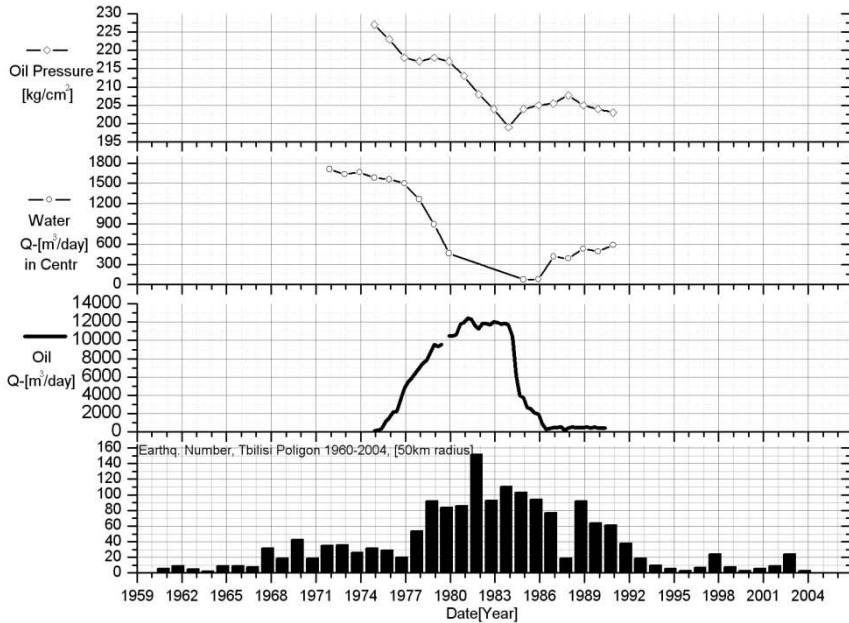

Fig.1. Underground fluids regime and seismic activity in Tbilisi hydrothermal field (THF); a) oil pressure (Samgori field), b) water debit in well 1BG (m³/day), c) oil production (m³/day), d) number of earthquakes per year 1960-2004 (according to catalog TSO1).

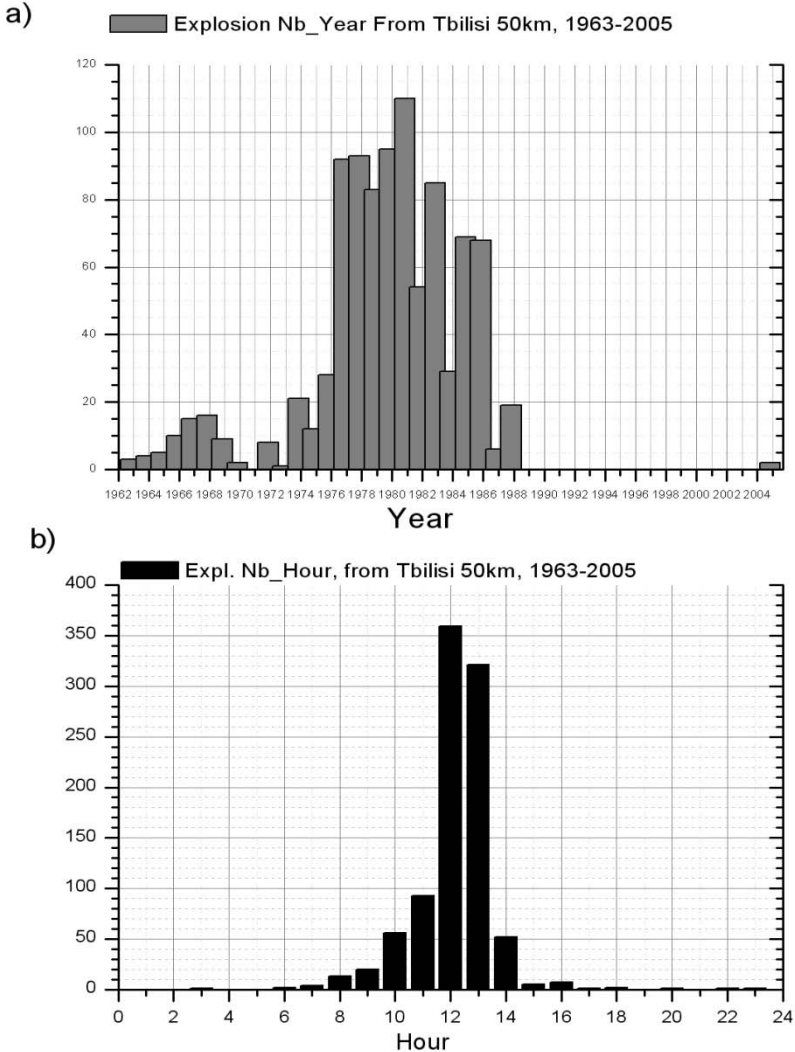
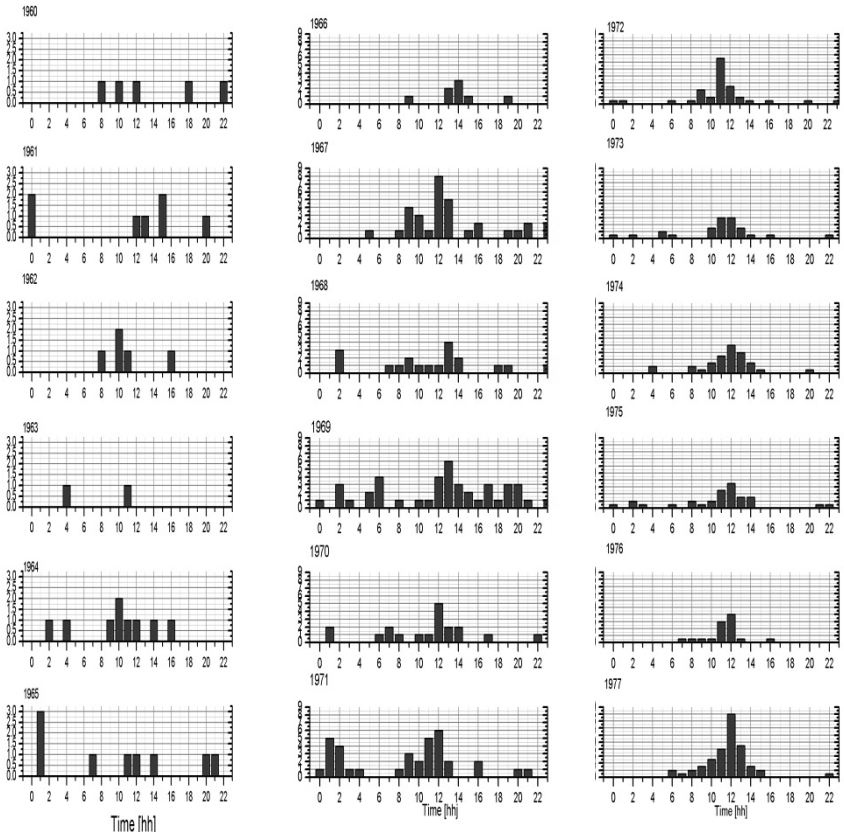

Fig. 2. a) Distribution of total number of explosions in Tbilisi region in 1960-2004; b) Diurnal distribution of total number of explosions in the same time interval.

Research workshop on Exploration and Exploitation of Groundwater and Thermal Water Systems in Georgia



Research workshop on Exploration and Exploitation of Groundwater and Thermal Water Systems in Georgia

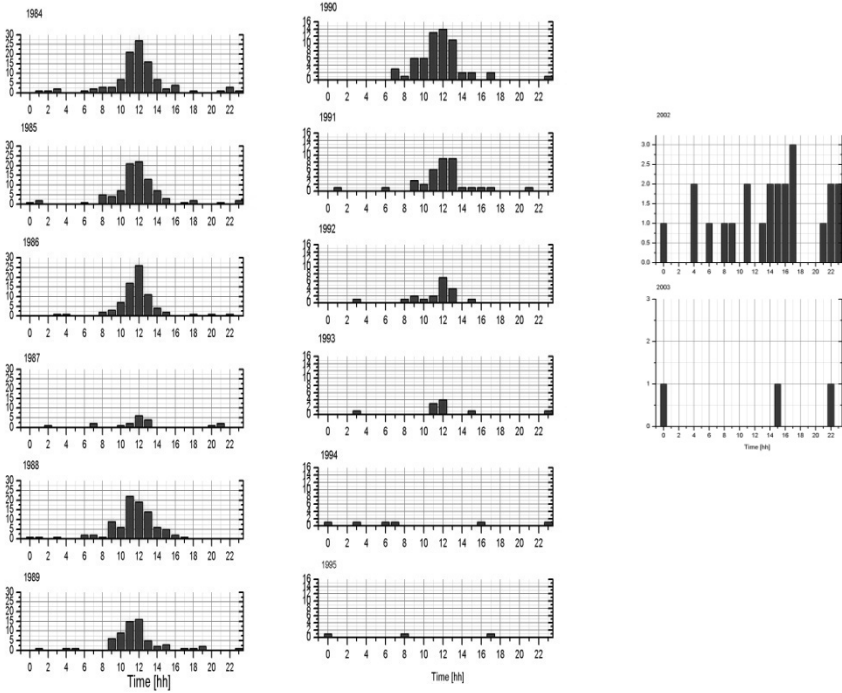

Fig. 3. Diurnal distribution of seismic activity in Tbilisi region for different years from 1960 to 2004. On the y-axis is given the number of earthquakes per hour.

As it could not be excluded that the maximum of SA was a consequence of explosion activity, from the catalog TSO1 were eliminated all events which occur around 12 h G.M.T, namely in the interval 10-14 hours (Fig. 4).

Research workshop on Exploration and Exploitation of Groundwater and Thermal Water Systems in Georgia

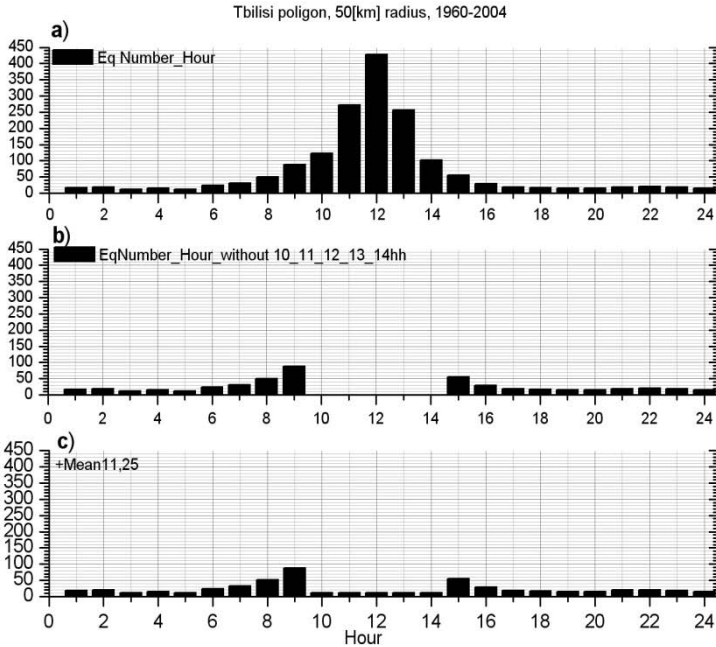

Fig.4. a) The diurnal distribution of SA from the catalog TSO1; b) The same without events which occur around 12 h G.M.T, namely without EQs occurred in 10, 11, 12 and 13 hours;

In order not to decrease the natural rate of seismic activity in the interval 12-14 h by total exclusion of seismic events, the mean annual number of EQ was added to the distribution in the above interval (Fig. 5).

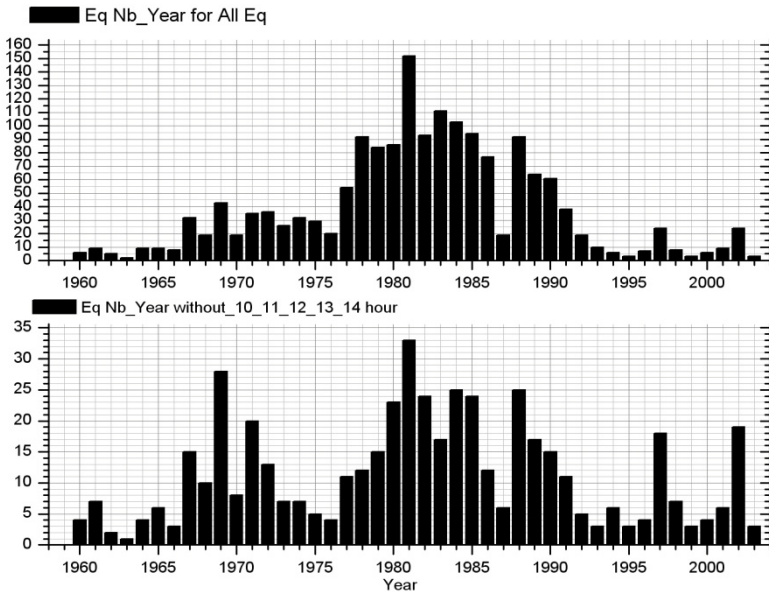

Fig.5. a) The annual EQs distribution , catalog TSO1; b) The same after exclusion of 4 hours interval around 12 h G.M.T. and addition instead of average (for 1960-2004) number of EQs per year.

It is evident that the increase of SA is present even after exclusion of possible explosion events. Besides the main maximum in 1974-1991 there are also three smaller maxima (Fig.5b). The SA rate increase around 1969, 1997 and 2002 are probably connected with the aftershock activity after relatively strong EQ of magnitude $M \geq 4$ in mentioned years (Fig. 6).

It should be stressed that the increased SA around 12 h G.M.T is present even in the catalog TSO2 (Fig. 7), where only events of magnitude $M \geq 2.5$ are included; as explosions have not such amplitude this means that they can not affect the distribution.

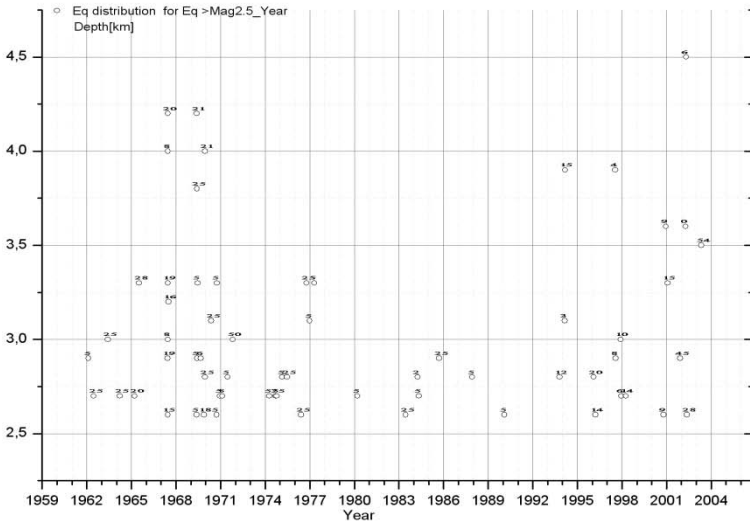

Fig. 6. Occurrence of earthquakes of $M \geq 4$ versus time in 1960-2004

All this evidence lead us to the conclusion that the time-dependence of SA in the period 1970-1989 in Tbilisi region reflects a complex process, which is affected by interaction of several factors. The main components of the process are: extraction of oil, change of pore pressure, industrial explosions, induced seismic events.

The most probable explanation of peculiarities in annual and diurnal distribution of EQ in connection with varying underground fluid regime in the region can be formulated in the following way: the intensive oil extraction in 1970-1989 changes the pore pressure distribution in the region and creates in the part of it Coulomb stresses which are favorable for fracture, i.e. a high strain sensitivity regime is created (Fig. 1). In the same period regular (around 12 h G.M.T) industrial explosions (Fig. 3, plots for 1970-1990) due to a high sensitivity of region to weak external impacts induce seismic activity of significant amplitude, namely events of $M \geq 2.5$, synchronized with the explosion regime, (Fig. 7) i.e. with a peak at 12 h G.M.T. The theory of synchronization as a universal concept as well as examples from various fields is given in (Pikovskiy et al., 2003).

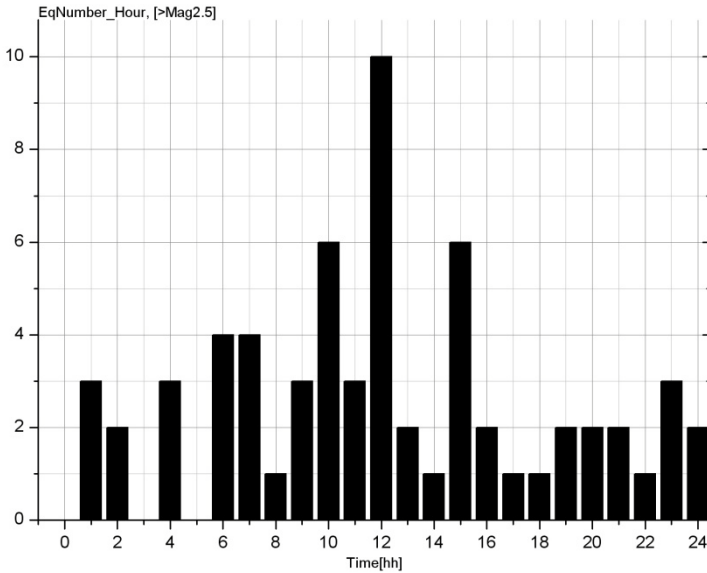

Fig. 7. Diurnal distribution of events of magnitude $M \geq 2.5$

Explosions, realized in the certain hour (hours) of the day can be considered as a weak quasiperiodic forcing superimposed on the much larger tectonic driving forces, which are also much slower than the forcing (the latter is a necessary condition for synchronization). The experimental laboratory studies confirm possibility of synchronization of acoustic/seismic activity under weak external forcing (Chelidze et al., 2003, 2005, 2006, 2007).

Of course, the synchronization of SA by explosion regime presumes the nonlinear interaction between tectonic processes and weak external impact, leading to forcing of SA by explosion.

One more interesting fact can be also marked: during 1970-1989 the number of strong seismic events decreases (Fig. 6) but the total number of events significantly increases. This can be interpreted as the result of quantification of SA due to synchronization phenomenon. The point is that synchronization controls not only the timing of seismic response – it can also regulate energy release: forcing means that synchronization limits the energy release associated with individual events as it promotes regular

energy discharges so that very large strains can not accumulate in the medium (quantization effect). The suggested explanation has yet to be proved finally as the gap in the relatively strong SA can be connected with the natural peculiarities of regional tectonic process.

Conclusions

The analysis of fluid regime and seismic activity in the Tbilisi Hydrothermal Field (THF) before, during and after intensive hydrocarbon production in the period of 1971-1984 was carried out.

The fluid regime change in these years shows that the pore pressure in some part of the region decreased drastically causing extinction of thermal water spring.

Around the same period the seismic activity increased significantly. The effect is present even after exclusion of possible artifacts connected with industrial explosions and it can be seen in distribution of earthquakes of magnitude $M \geq 2.5$, which can not be identified as explosions.

The following hypothesis on the complexity of phenomenon is formulated: the oil production and pore pressure change in some parts of the region lead to changes in the Coulomb stress, which are favorable for triggering induced seismicity (there is nonlinearity in seismicity response to weak external impact). Due to high sensitivity of the region the induced seismic activity of significant amplitude is synchronized with the explosion regime, i.e. it reveals a peak at 12 h G.M.T even for earthquakes of magnitude $M \geq 2.5$.

References

- Gupta, H. and Rastogi, B.** (1976) Dams and Earthquakes. Elsevier, NY.
- Grasso, J.-R., Sornette, D.** (1998) Testing self-organized criticality by induced seismicity. Jour. Geophys. Res. 103 B. 29965-29987.
- Pikovsky A., M.G. Rosenblum and J. Kurths,** 2003, Synchronization: Universal concept. Cambridge UP.
- Chelidze, T., and O. Lurmanashvili,** 2003, Electromagnetic and mechanical control of slip: laboratory experiments with slider system. Nonlinear processes in Geophysics, 20, 1-8

Chelidze, T., T. Matcharashvili, J. Gogiashvili, O. Lursmanashvili and M. Devidze, 2005, Phase synchronization of slip in laboratory slider system. Nonlinear Processesing Geophysics, 12, 1-8

Chelidze, T., O. Lursmanashvili, T. Matcharashvili and M. Devidze, 2006, Triggering and synchronization of stick slip: waiting times and frequency-energy distribution Tectonophysics, 424, 139-155

Chelidze T., and T. Matcharashvili, 2007, Complexity of seismic process, measuring and applications – A review, Tectonophysics, 431, 49-61

**DYNAMICS OF EARTH CRUST TILTS AND SEISMICITY AT
ENGURI DAM INTERNATIONAL TEST SITE DURING DAM
CONSTRUCTION AND RESERVOIR FILLING.**

**TAMAZ CHELIDZE, TEIMURAZ
MATCHARASHVILI, VAKHTANG ABASHIDZE,
NATALIA ZHUKOVA, EKATERINE MEPHARIDZE**
Mikheil Nodia Institute of Geophysics

The study is dedicated to the analysis of dynamics of earth crust tilting process and local seismicity at International test area of Enguri hydro power station. We aimed at qualitative and quantitative evaluation of dynamical characteristics of earth tilt and seismic time series in the context of ongoing development of telemetric monitoring system at Enguri test area. Data sets of tilt hourly time series recorded during construction of Enguri power station and filling of its reservoir (1971-1983) as well as local seismic catalogue have been analyzed. Modern methods of linear and nonlinear time series analysis have been used. It was shown that earth tilt sequences reveal clear properties of low-dimensional dynamics. Quantitative changes in dynamics of tilt generation connected with different stages of anthropogenic influence, such as construction of Enguri high dam and filling of reservoir, also have been detected. It was established, that these changes are transient and the character of Earth tilt dynamics was restored at the end of observation. The dynamical patterns of seismicity are also similar to tilt behavior.

Keywords: Linear and nonlinear dynamic analysis, high dam.

Triggering and synchronization of earthquakes by the water level changes in deep enough reservoirs is a subject of intense interest both from the practical and scientific points of view. For the last two decades it has been documented that large water reservoirs can cause reservoir induced seismicity (RIS) (Talwani, 1997; Simpson, 2003). The strength of reservoir-triggered earthquakes range from damaging earthquakes, with fractures of the order of kilometres to rock bursts and micro-seismic emissions which are mostly sensed by instrumentation and have range of failure of a scale of meters. According to (Talwani, 1997), RIS phenomenon may take place either due to the change of the state of the earth crust stress by the weight of water, or by increased groundwater pore pressure decreasing the effective strength of the rocks around the reservoir.

The importance of small periodic influences on the complex systems behavior is well acknowledged. In the present research the possible impact of water level variation in large reservoir on the dynamics of local seismic activity was investigated. Large reservoirs located in the seismically active zones are often considered as a factor, quantitatively and qualitatively influencing earthquakes generation. During impoundment or after it both the number and magnitude of earthquakes around reservoir significantly increases. After several years these changes in earthquake generation, named as reservoir induced seismicity (RIS) essentially decreases down to the level, when lesser earthquakes occur with lower magnitudes. To explain this decrease, authors of present paper recently proposed the model of phase synchronization of local seismic activity by the periodic variation of the water level - reservoir induced synchronization of seismicity (RISS).

Generally RISS presumes a kind of control of local seismic activity by synchronizing small external periodic influence and hence increase of order in dynamics of regional seismic activity. To reveal these changes in dynamics of phase synchronized seismic activity around large reservoir field seismic and water level variation data were analyzed in the present work.

For triggered earthquakes to occur, both mechanisms require that the area is already under considerable tectonic stress that can be released due to the reservoir influence. Therefore, induced seismicity should be a transient phenomenon, which will occur either immediately after filling of the reservoir, or after a delay of a few month or even years depending on the permeability of the rock beneath the reservoir. Therefore, once the stress

and pore pressure fields stabilised at new values, the reservoir induced seismicity has to decrease. Earthquake hazard should then revert to the level that existed before the reservoir building due to decrease of amount of local tectonic stress perturbation.

In the present study we investigated the change in regional seismic activity around Enguri hydro power station reservoir, located in the Western Georgia.

The basis of our investigations are the water level variation data sets of the unique in the world Enguri high arc dam reservoir located in the western Georgia and the seismicity data sets of surrounding territory for 1973-1995

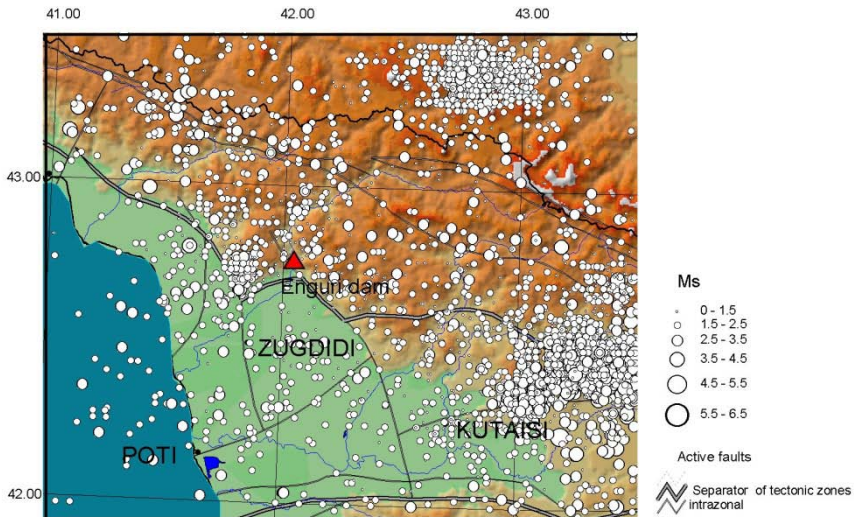

Fig. 1. Seismicity at Enguri Dam Area, 1973-1995

The height of the dam is 272 m, the (average) volume of water in the reservoir $1.1 \cdot 10^9 \text{ m}^3$. Enguri reservoir was built in 1971-1983. Preliminary flooding of the territory started at the end of December 1977; since 15.04.1978 reservoir was filled step by step to a 510 m mark (above the sea level) in 1987. Since 1987 the water level in reservoir changes seasonally, almost periodically. Thus we have defined three distinct periods of our

analysis, namely, (i) before impoundment, (ii) flooding and reservoir filling and (iii) quasi-periodic change of water level. Fig. 2 shows the daily record of the water level in the Enguri dam reservoir in 1978-1995.

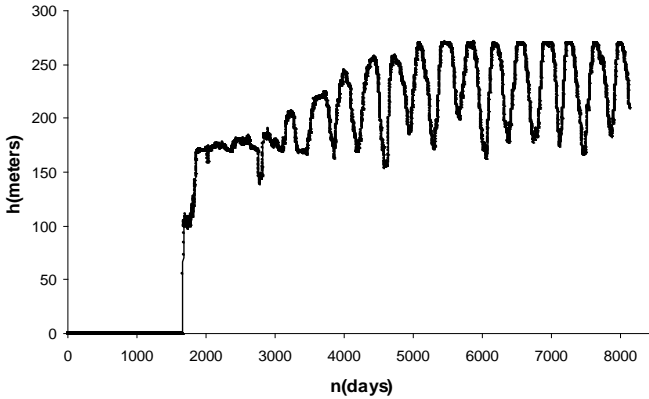

Fig. 2. Water level change in Enguri reservoir in 1978-1995.

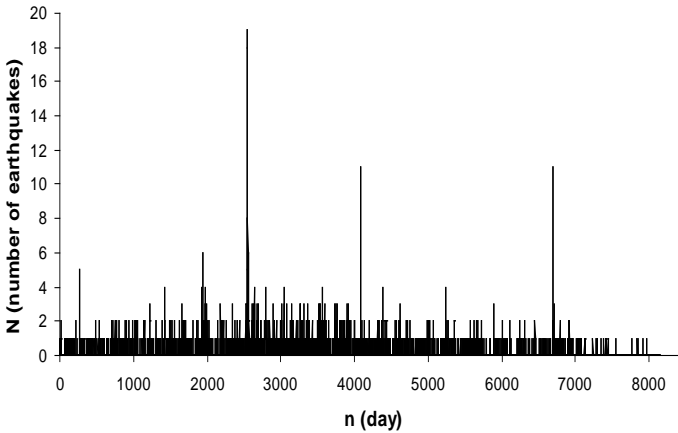

Fig. 3. Local seismicity change in Enguri reservoir in 1978-1995.

We focus on the revealing the phase synchronization between water level in the lake and local seismicity (in the area within 90-95 km distance from the lake). It is evident that good synchronization of seismicity with some weak forcing is much more convincing proof of their interdependence than looking at triggering effect, which can be a result of accident.

In order to evaluate the strength of functional dependence between water level variations in reservoir and seismic energy release we used the averaged mutual information as a measure of the statistical independence between analysed data sets (namely, water level and local seismicity):

which is defined as (Abarbanel, 1993; Kantz, 1997):

$$I = \sum_{i=1}^N P(x(i), x(i+T)) \log_2 \left[\frac{P(x(i), x(i+T))}{P(x(i))P(x(i+T))} \right], \quad (1)$$

where $P(x(i))$ is probability of finding $x(i)$ measurement in time series, $P(x(i), x(i+T))$ is joint probability of finding measurements $x(i)$ and $x(i+T)$ in time series and T is the time lag.

Mutual information (MI) between cumulative sums of daily released seismic energy and water level daily variations calculated for extended in 365 data windows.

As an additional quantitative tests for assessment of temporal variation of phase synchronization (Pikovsky et al, 2003) the Shannon entropy was calculated for the mentioned phase difference sequence.

In order to reveal hidden details of complex dynamics of acoustic emission under external influence we have used the method of recurrence plots (RP) (Eckman et al., 1987) and recurrence quantification analysis (RQA), namely, the percent of determinism - $Det\%$ - see Figs. 7,8 (Zbilut et al., 1992; Marwan et al., 2003).

To characterize the seismic activity for the period from 1973 to 1995 different statistical features were evaluated (see also Peinke et al., 2006). To show how the amount of energy release depends on the strength of the seismic activity, we analyse how the according quantities depend on different threshold values E_{th} of the daily seismic energy release. The threshold values were selected so as to include values below and above the mean released daily seismic energy, $E=4 \times 10^8$ Joules. For this analysis a one

year sliding window is used, which was chosen in accordance with the periodicity of the water level dynamics. Thus, Fig. 5 shows the number of days during one year with $E > E_{th}$ normalized to the total number of days.

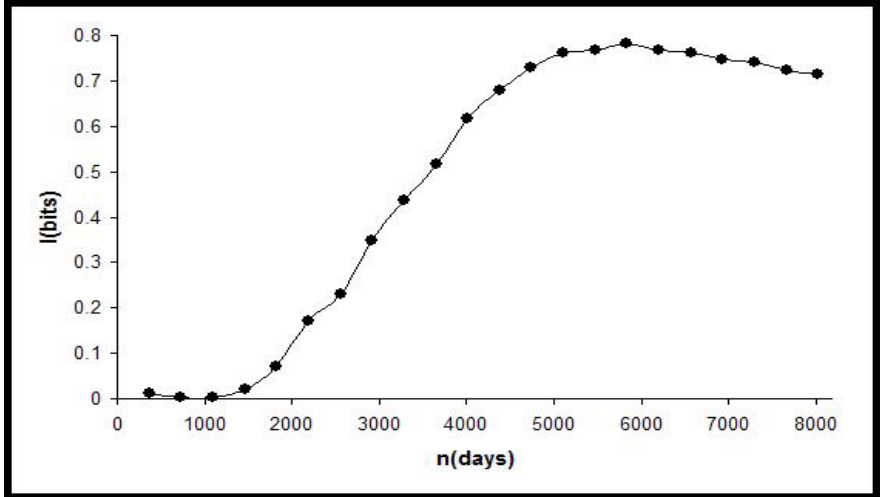

Fig. 4. Mutual information extent between cumulative sums of daily released seismic energy and water level daily variations versus time. Note increase of MI at periodic water level variation

The increase of seismic activity around Enguri high dam associated with impoundment can be attributed to the “rapid” response. On the other hand after this initial RIS period, when variation of water level became more or less periodic, strong events occurred rarely (Fig. 6).

The results of calculation of frequency of days when the threshold values were exceeded confirm the conclusion about stabilisation of seismicity around Enguri high dam reservoir on a relatively low level during the last period of reservoir exploitation. Indeed, the probability that the threshold value will be exceeded (circles in Fig. 6) strictly decreases to the threshold value about 100 times smaller than for the pre-impoundment level.

Research workshop on Exploration and Exploitation of Groundwater and Thermal Water Systems in Georgia

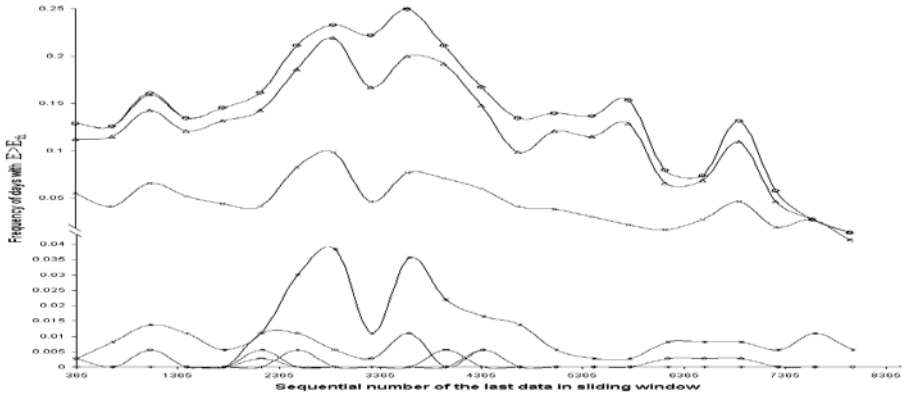

Fig. 5. Frequency of exceeding the threshold value of daily released seismic energy calculated for 365 day length sliding windows with 365 day step. Curves 1-9 (from top to down) correspond to increasing threshold values E_{th} of released daily seismic energy: 5×10^4 , 5×10^5 , 5×10^6 , 5×10^7 , 5×10^8 , 5×10^9 , 5×10^{10} , 2.5×10^{11} , 5×10^{11} Joule per day.

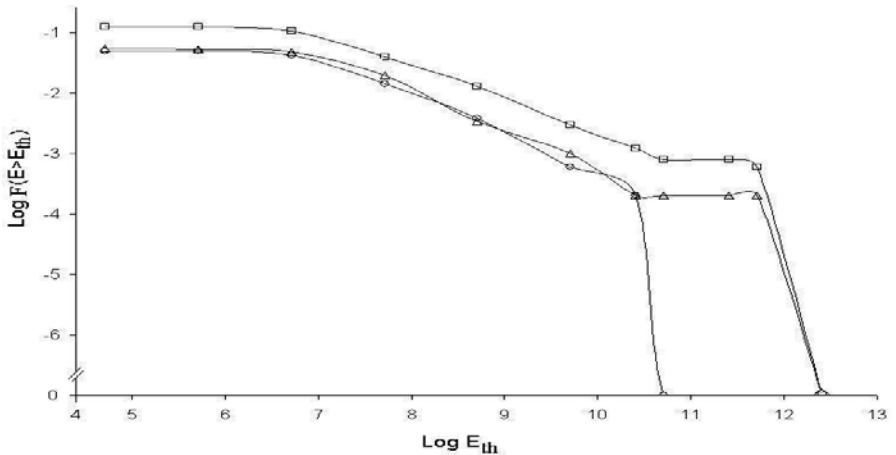

Fig. 6. Log-Log plot of frequency of exceeding the threshold value of emitted daily seismic energy calculated for time periods before impoundment (triangles), during flooding and reservoir filling (squares) and during periodic variation of water level in reservoir (circles).

Numbers 1-11 at the bottom correspond to threshold values : 5×10^4 , 5×10^5 , 5×10^6 , 5×10^7 , 5×10^8 , 5×10^9 , 5×10^{10} , 2.5×10^{11} , 5×10^{11} Joules per day

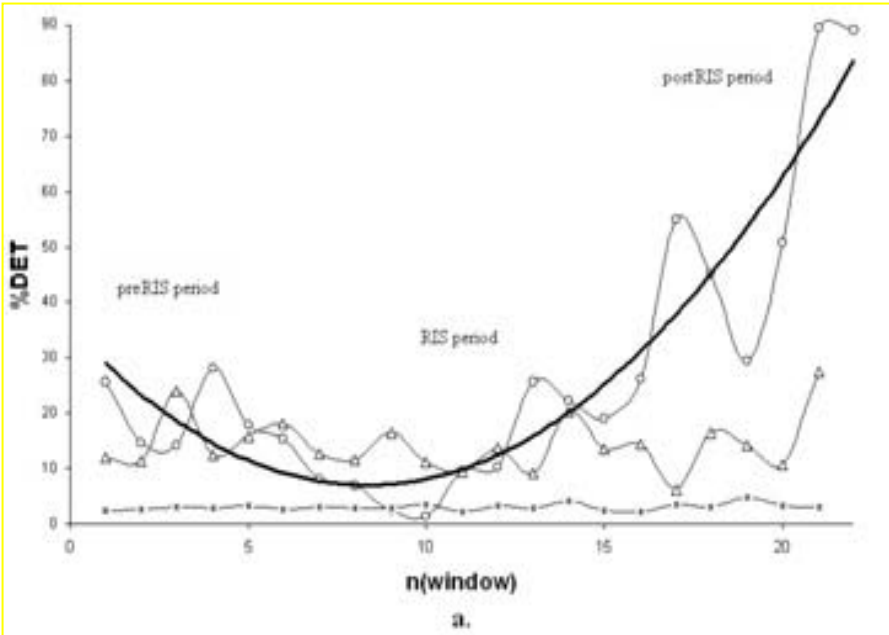

Fig. 7 RQA % DET of daily number of earthquakes calculated for consecutive non overlapping one year sliding windows (circles). Averaged results of RQA % DET for 20 shuffled (asterisks) and phase randomized (triangles) surrogates of daily number of earthquakes in consecutive one year sliding windows;

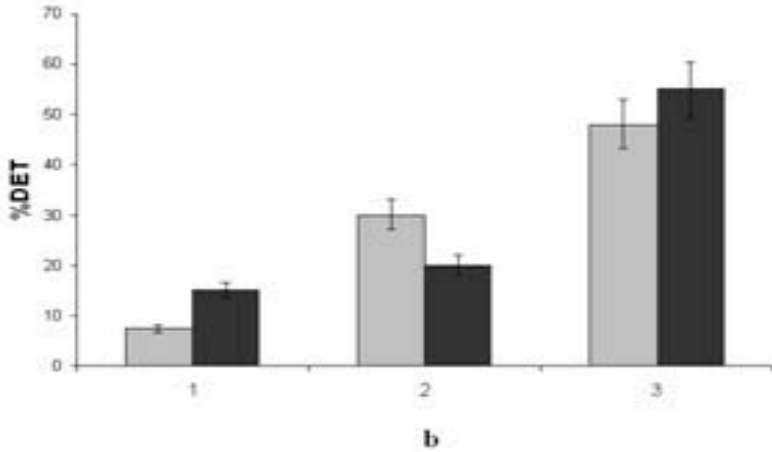

Fig.8. RQA % DET of magnitude (black columns) and waiting time (grey columns) sequences: (1) preRIS, (2) RIS and (3) postRIS.

The effect of reservoir on is rather small compared to the regional tectonic stress field.

The level of water in the lake changes by 100 m, which means that the pressure at the bottom changes by 10 bar. At the depth of 10 km, where the most of hypocentres of EQ are located, the pressure will be much less, as the reservoir is finite. We use for the crude assessment of the order of load decrease a well known expression for the stress field of a defect $\Delta\sigma$ at the distance r from it:

$$\Delta\sigma/\sigma \approx (a/r)^{1/2},$$

where σ is applied stress, a is the size of defect. Substituting $\sigma = 10 \text{ bar}$, $a = 100 \text{ m}$ (the depth of lake) and $r = 10\,000 \text{ m}$ (the average depth of hypocenters) we obtain for $\Delta\sigma$ the value of order of 1 bar. This is much less than the tectonic stress on this depth, which is of the order of several kilobars.

Research workshop on Exploration and Exploitation of Groundwater and Thermal Water Systems in Georgia

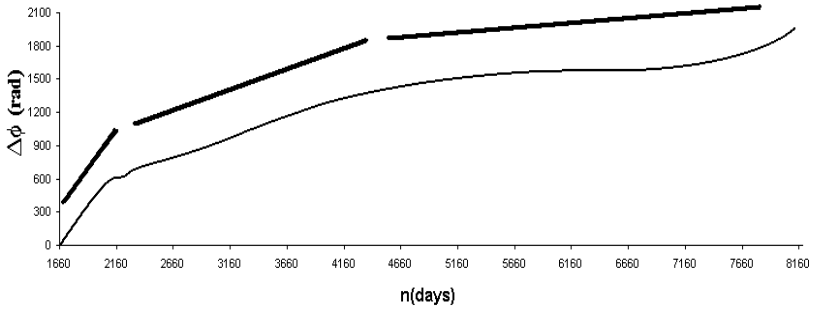

a.

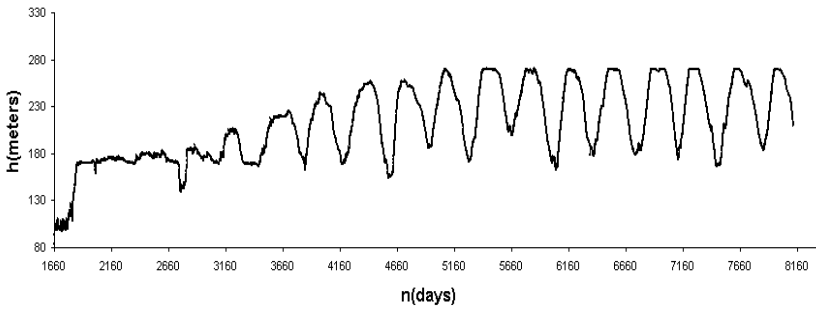

b.

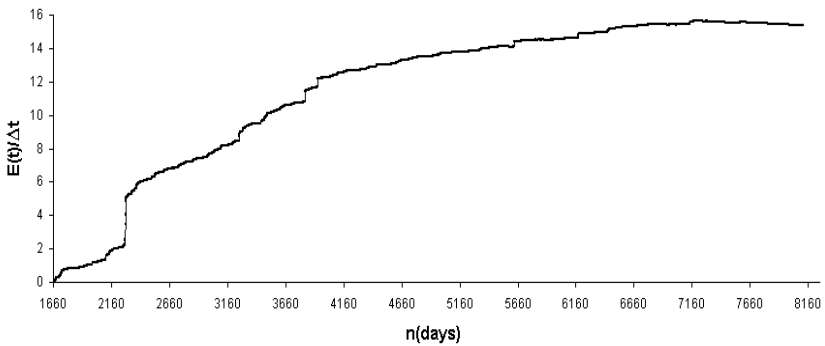

c.

Fig. 9. Phase differences between phases of velocity of Benioff strain increase and daily water level variation. b) Daily water level variation, c) velocity of Benioff strain increase.

Based on results of our analysis we present concept of reservoir induced seismicity synchronization (RISS) explaining decrease of seismic activity around the Enguri dam after preliminary increased RIS as a result of phase synchronization between water level variation in the lake and regional seismic activity. We guess that under external weak periodic influence (during RISS) the existing tectonic energy may be released via series of relatively small earthquakes due to regularization of tectonic process by external forcing, which excludes accumulation and quick release of extreme stresses.

In order to study the seasonal effect we carried out the analysis of dependence of earthquakes monthly distribution on reservoir water level, Fig. 10. Here monthly frequency of earthquake occurrence (MFEO) is calculated as a ratio of earthquakes monthly number occurred during last 8 years of water level periodic variation, normalized to the total amount of earthquakes for the same period. Similar calculation was carried out for the first five years of observation, when seismicity was not influenced by water level variation. As it follows from Fig. 10, when water level variation is periodic, earthquake occurrence looks unimodally distributed with maximal frequency of earthquakes occurrence in April, when the water level is maximal. At the same time before reservoir influence earthquakes distribution was almost uniform.

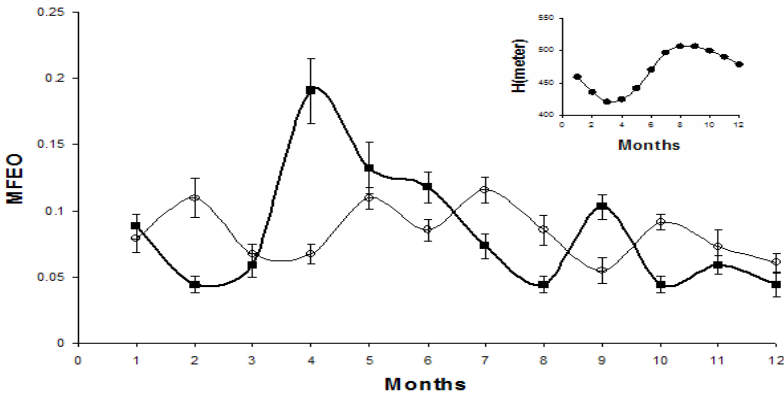

Fig. 10. Monthly frequency of earthquake occurrence before (open circles thin line) and during water level periodic variation (dark squares bold line).

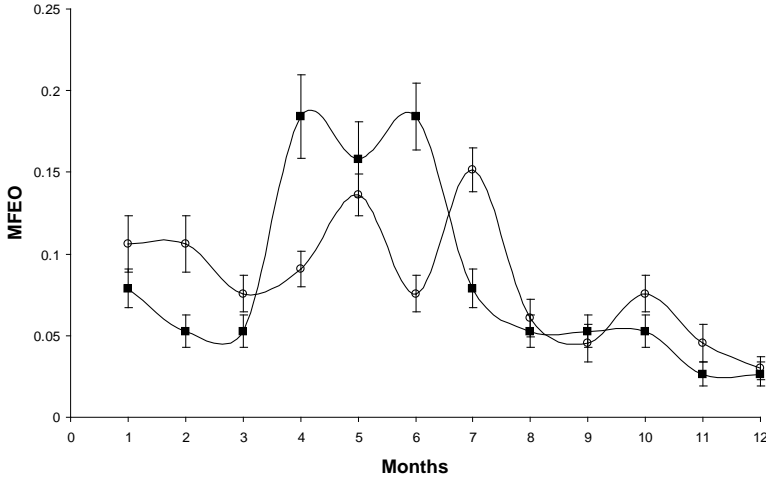

Fig. 11. Monthly frequency of earthquakes occurred in the local night before (open circles) and during water level periodic variation (dark squares).

Two possible explanations can be suggested for such behavior: difference in the direct load-unload response (LURR), which implies immediate response to load or pore pressure diffusion, which means that seismic response lag behind load, due to slow redistribution of pore fluid in the pore space. As the seismicity follows loading without delay, the direct effect seems to be more probable.

The asymmetry of system's response to load and unload is explained by nonlinearity of mechanical behaviour of damaged (close to fracture) solid due to nucleation and merging of defects and is measured by load-unload response ratio (LURR) Y : $Y = X+/X-$, where $X+$ and $X-$ are system's response rates R at load and unload correspondingly; $X = \lim (dR/dP)$ at $dP \rightarrow 0$; here P is a load. In nonlinear system $Y > 1$, as the response to load is larger than to unload. In our case the response R is the monthly frequency of earthquakes and $Y = 4$, i.e. Y is significantly larger than 1. This interpretation corresponds to so called direct mechanical effect of loading and reflects the presence of hysteresis in the stress-strain dependence (and seismic energy release) in damaged (diluted) solids.

Conclusions

We present the evidence of reservoir-induced changes in regional seismicity around the Enguri high dam reservoir. It is shown that under the influence of a large water reservoir, regional seismic activity initially increases according to the well known concepts of reservoir induced seismicity (RIS). After a period of reservoir-induced initial increase of regional seismic activity, the released energy value essentially decreases when the variation of the water level in the lake became periodic.

Statistical, linear, nonlinear and phase synchronization analysis methods have been applied to field and laboratory data in order to obtain quantitative assessment of synchronization strength.

Based on field and laboratory data analysis we suppose that decrease of probability of large earthquakes occurring around large reservoirs may be explained as a result of synchronization (quantization) of complex seismic process under small periodic forcing caused by change of water level. We call the effect the Reservoir Induced Seismicity Synchronization (RISS).

Increase of order in earthquakes temporal distribution at proposed phase synchronization was revealed by the method recurrence quantitative analysis (RQA).

It was shown, that when external forcing on the earth crust caused by reservoir water regulation become periodic, the extent of regularity of earthquake daily distribution essentially increases. Calculation of load-unload response ratio (LURR) shows that there is clear asymmetry in seismicity rates during filling and discharge phases of lake exploitation.

As a model of natural seismicity we also analysed laboratory acoustic emission data obtained during stick-slip experiments with superimposed weak periodic perturbations. Most of synchronization regularities, observed in reservoir-induced seismicity were found in the laboratory model also.

Acknowledgements

Authors acknowledge financial support of joint project (# 5016) of Georgian National Scientific Foundation (GNSF) and Science and Technology Center of Ukraine (STCU).

References

- Eckmann, J.P., Kamphorst, S., Ruelle, D.,** Recurrence plots of dynamical systems. *Europhysics Letters*, 49,73-977, 1987.
- Marwan, M.,** Encounters with neighborhood, PhD Thesis, 2003.
- Peinke, J., Matcharashvili, T., Chelidze, T., Gogiashvili, J., Nawroth, A., Lursmanashvili, O., Javakhishvili, Z.,** Influence of Periodic Variations in Water Level on Regional Seismic Activity Around a Large Reservoir: Field and Laboratory Model, *Physics of the Earth and Planetary Interiors*, 156/1-2, 130-142, 2006.
- Pikovsky, A., Rosenblum, M. G., Kurth. J.,** *Synchronization: Universal Concept in Nonlinear Science*, Cambridge University Press, Cambridge, 2003.
- Simpson, D. W.,** ‘Triggered earthquakes’, *Annual Reviews of the Earth and Planetary Sciences*. 14, 1986, 21-42.
- Simpson, D., Leith, W., Scholz, C.,** ‘Two types of reservoir-induced seismicity’, *Bulletin of Seismological Society America*, 78, 1988, 2025-2040.
- Talwani, P.** ‘On nature of reservoir-induced seismicity’, *Pure and Applied Geophysics*, 150, 473-492. 1997.
- Zbilut, J. P., Webber, C. L. Jr.,** Embeddings and delays as derived from quantification of recurrence plots. *Physics Letters A*, 171: 199-203, 1992.

CREATION OF NUMERICAL MODEL OF TBILISI GEOTHERMAL DEPOSIT

**NINO KAPANADZE, GENADI KOBZEV, GEORGE I.
MELIKADZE**

Institute of Earth Sciences, Ilia State University

NATALIA ZHUKOVA

Mikheil Nodia Institute of Geophysics

The geothermal reservoir of Tbilisi is the most promising one; thus assessment of its conditions should be regarded as the most important task. This paper summarizes the geothermal potential of Tbilisi region. Based on existing and newly obtained geologic, hydrogeological and geophysical data, 3D model of thermal region was created. As a result of modeling work, the 10 year perspective of thermal deposit of Tbilisi was assessed for present conditions of exploitation.

Keywords: Tbilisi geothermal deposit, numerical modeling.

Introduction

Urban centre of Tbilisi is of a particular importance with its multilateral and dimensioned consumer existence, thermal waters resources, unlimited perspective of development and a population of 1.5 million inhabitants. Tbilisi thermal waters' deposit as a result of historical and research works' chronology, conditionally has been divided in 3 exploitation sections: central or balneology resort and baths section, Lisi-Saburtalo section and Samgori-Sartichala oil field section, which is related to the same Middle Eocene thermal water horizon, unlike two previous ones. Up-to-date hydrodynamical relations of these 3 regions (Lisi, Central and Oil) are not

well investigated, and it is impossible to conduct environmentally and economically optimized exploitation of balneological and thermal waters without detailed monitoring of hydrogeological regime. Use of heat energy of ground hydrothermal resources for therapeutic and heating aims is traditional worldwide and detailed research of hydrodynamic and hydrochemical characteristics of exploitation area is significant. Commonly, for such hydrothermal resource we need three dimensional model construction for both hydrodynamic and thermal regime. It is well known that three dimensional digital modeling, hydrodynamic and thermal gradients' selection is of big importance for estimating proper regime of low thermal-consisting hydrothermal pools' with ecologically proved exploitation conditions. As a rule, in such environment, ground water flow is related not only to the hydrodynamic gradient, but to the temperature gradients as well, which can govern density changes in the flow as well as its movement. The modeling studies will use existing data and those obtained from boreholes.

Establishment of boundary conditions for targeted area and creation of conceptual model

The modeling have been fulfilled by software Feflow 5.3, which enables computing a 3D thermal model of the region. For this purpose, a 3D geometric model was prepared beforehand by the software ArcMap 9.2 and ArcView 3.2a.

Based on analysis of geologic and hydrogeologic data a conceptual model was created. This model assumes that Upper Eocene water-horizon of Tbilisi hydrothermal basin is water impermeable, what creates conditions for pressuring of underground water. It is assumed that there is little hydrodynamic connection between Tbilisi Central district and Lisi district. Several factors convince that this is true: hydraulic gradients in "Lisi" thermal field are much stronger and larger compared to the Central district, what points to the low permeability, though the depth of aquifer is the same at both sites (Fig. 1).

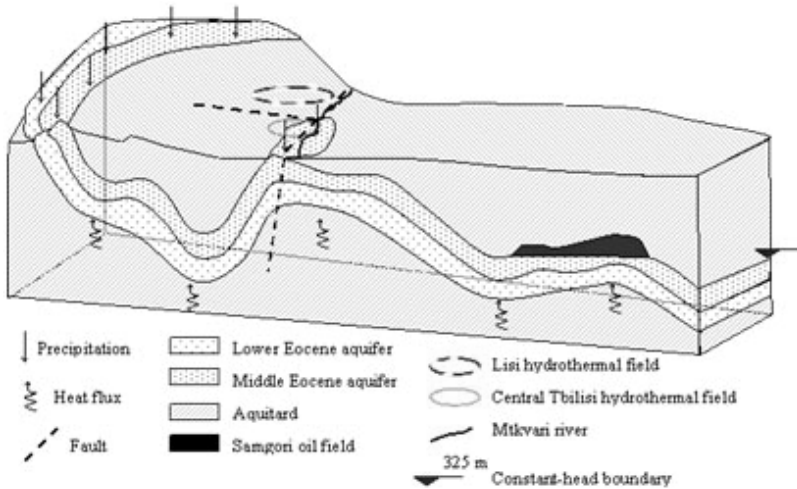

Fig. 1. Block diagram of conceptual model

Low values of transmissivity might be caused by the large depth of “Lisi” aquifer because lithostatic pressure of upper rock formation leads to decrease of cracks’ openings and decrease of their total volume and accordingly, of permeability. Decrease of pressure in the Central district leads to opening of cracks and thus to increased permeability.

Piezometric maps, mineralization and thermal profiles point to regional West-East flow of underground waters. In other words ground waters flow from mountainous recharge area with low mineralization to the deepest horizons in the west, where underground fluids (water and oil) have much higher temperatures and mineralization.

In the model, North and South boundaries of hydrothermal basin are confined by narrow impermeable belt, because there are no manifestations of thermal water beyond this belt. Similar boundary could be proposed for the East boundary of oil field, what leads to the hypothesis on existence of deep faults here, which represents physical boundary for aquifer. In any case these boundaries are not crossed by water, they coincide with flow direction and thus are considered as water impermeable. Boundaries of water containing horizon in the model were defined as is shown in Fig. 2, where boundary westward to Mtkvari coincides with the recharge area of

aquifer and lateral boundaries (North and South) follow aforementioned water impermeable belts. East boundary was set up conditionally in 40 km from thermal districts.

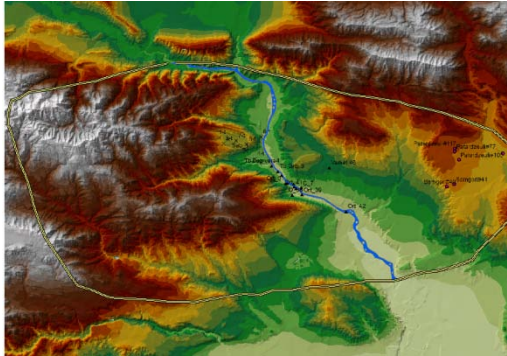

Fig. 2. Boundary of Tbilisi Thermal region.

Outcrop zone of Middle and Lower Eocene represents the main recharge source for water containing horizon. Consequently this zone is considered as a constant boundary for the descending water flow. The area of outcrops of Middle Eocene rocks of Lisi district is 87.7 km² and the total area of outcrops of recharge area at the Central district is 126 km². The mean value of precipitation is 550 mm per year, only part of which reach depth and its amount is calculated below (Fig. 3).

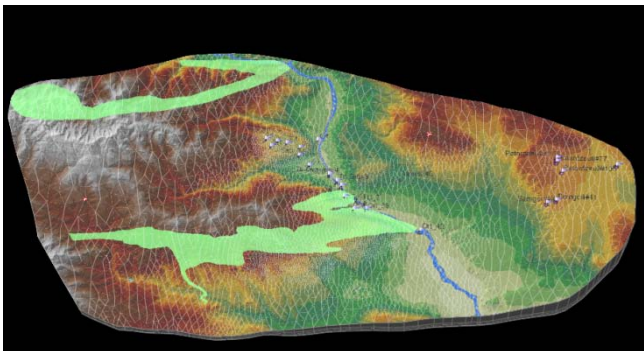

Fig. 3. Recharge areas

Total area of the model region was 2037 km². Difference in the heights of profile was 9.4 km.

According to hydrologic conditions the model is divided into three parts (Fig. 4). Area of North-West part of model is 493 km², that of central part 842 km² and the area of Samgori Patardzeuli oil field 700 km². The former is divided by the fault and consists of two parts - Northern and Southern parts (255 km² and 445 km² accordingly).

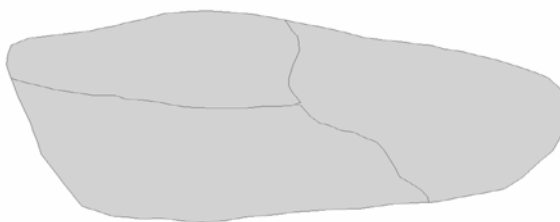

Fig. 4. Contours of three thermal districts.

It is assumed that there is little hydrodynamic connection between Tbilisi Central district and Lisi district. Several factors convince that this is true:

Below (Table 1) hydraulic (piezometric) heads are provided for Lisi-Saburtalo and Central district, what confirms essential differences between them.

Table 1. Elevation of boreholes in Tbilisi area

Name	Altitude above sea level in meters	Hydraulic head in meters (for open wells)	Hydraulic head in meters (for closed wells)
Lisi district			
1-Sab	532	598.08	661.10
4-t	454	527.80	693.70
5-t	656	659.09	666.90
6-t	434	555.60	666.60
7-t	653	662.28	669.94
8-t	639	652.10	666.00
Central district			
Botanic Garden	415	413	413

As it follows from Table 1, hydraulic head of Lisi wells are similar and they are self (gravity) flowing, though hydraulic head of well in Botanic Garden is smaller by 250 m and has a negative level, 2 m below day surface. This could be caused by presence of tectonic fault between these two districts. Two deep faults are established within the area of Tbilisi hydrothermal deposit, correct account of which has fundamental importance for hydrodynamic and thermal conceptual model. Namely, the lateral fault has been revealed along river Mtkvari. It is partially discharge area for Central district and same time as recharge area for oil field. This of course decreases movement ability of underground water. Moreover, by geophysical investigations, including seismic ones, the long West-East lineament has been established, which separates Lisi district from the Central district. This lineament is assumed as having low permeability and weak hydrodynamic connection between separate districts can be explained by its presence (Buntebarth et al., 2009).

Table 2. Water level and discharge data of Tbilisi wells

Well #	Q in m ³ /day	T in °C	P in atmosphere
	Lisi district		
1 sab	280	65	
4-T	480	68	
5-T	1684	60	
6-T	480	70	
7-T	294	60	
8-T	96	56	
	Central district		
25	28.5	33	
1 bot	432	-	
27	380.16	33	1.5
30	86.4	45	-
31	630.72	51	0.6
48	86.4	41	-
39	146.88	24	-

Debit and temperature of water horizons have been evaluated by data obtained from self-flowing wells in Lisi and Central district (Table 2).

Description of model boundary conditions

In order to involve both recharge and high pressure (Samgori oil field) areas the regional scale modeling has been carried out. This enables to set the boundary conditions, which as a rule are impermeable and coincide with physical boundaries of hydrothermal basin and to investigate influences of separate stresses, e.g. exploitation of hot water and oil (Fig. 5).

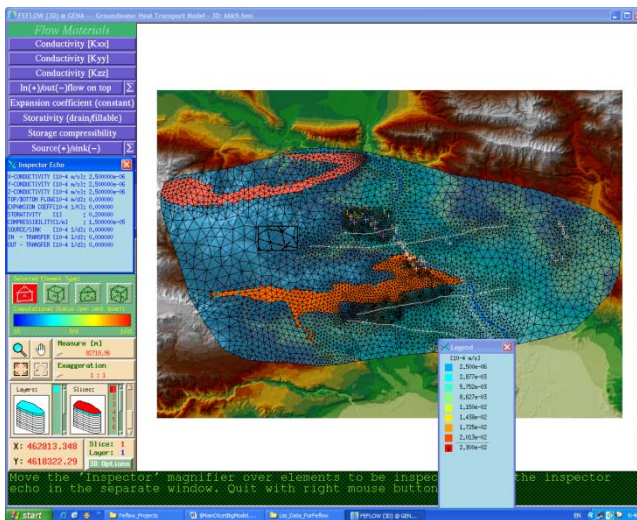

Fig. 5. Model with boundary conditions and fault system

Before vertical partitioning of the model the digital map of region has been created by ArcMap 9.2 and model boundaries have been contoured. The digital net of regional relief and its Z coordinates as shp files has been generated from space images.

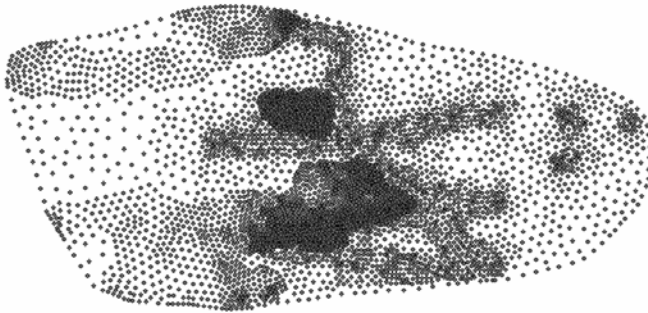

Fig. 6. Digital net of model surface.

This surface and its absolute heights were used as reference points for vertical partitioning of horizons. In the model three vertical zones have been defined corresponding to layers of practically impermeable Lower and Middle Eocene.

Input of hydrodynamic and temperature parameters

At first, for all layers, initial values of hydraulic pressure (piezometric levels) have been entered. Conditionally it corresponds to relief height for all layers. After analysis of real data, following hydraulic parameters were entered in the model:

Table 3. Values of hydrodynamic parameters

Lisi district	(Conductivity) Kx (m/s)
Upper Eocene	$2.5 \cdot 10^{-6} \cdot 10^{-4}$
Middle Eocene	$0.137 \cdot 10^{-4}$
Lower Eocene	$0.137 \cdot 10^{-4}$
Central district	Conductivity Kx (m/s)
Upper Eocene	$2.5 \cdot 10^{-6} \cdot 10^{-4}$
Middle Eocene	$5.7 \cdot 10^{-3} \cdot 10^{-4}$
Lower Eocene	$5.7 \cdot 10^{-3} \cdot 10^{-4}$
Patardzeuli district(North part)	Conductivity Kx (m/s)
Upper Eocene	$2.5 \cdot 10^{-6} \cdot 10^{-4}$

Research workshop on Exploration and Exploitation of Groundwater and Thermal Water Systems in Georgia

Middle Eocene	$2.8 \cdot 10^{-5} \cdot 10^{-4}$
Lower Eocene	$2.8 \cdot 10^{-5} \cdot 10^{-4}$
Patardzeuli district(Southern pat)	Conductivity Kx (m/s)
Upper Eocene	$2.5 \cdot 10^{-6} \cdot 10^{-4}$
Middle Eocene	$3.19 \cdot 10^{-2} \cdot 10^{-4}$
Lower Eocene	$3.19 \cdot 10^{-2} \cdot 10^{-4}$

Values of temperature parameters have been entered in special section of model, so called "transport data", where initial temperature distribution (Jimsheladze et al., 2008), rock thermal characteristics and thermal flow source values have been indicated. Their parameters were measured in laboratory (Sakvarelidze et al., 2008, 2009).

By calculation of initial values of thermal distribution the following scheme was used. At the model (day) surface the temperature was set as 15°C, for all bottom surfaces the following formula has been used:

$$T_p = T_k + (q/\lambda) \cdot H,$$

where T_p is the bedding temperature, T_k is the layer roof temperature, H is depth of layer, q is thermal flow, λ is coefficient of thermal conductivity of layer. For the whole model $q=0,041 \text{ W/m}^2$.

Table 4. Heat capacity for each water-horizon.

Name	heat capacity per unit volume in J/ m^3
Upper Eocene	$3.32 \cdot 10^6$
Middle Eocene	$2.55 \cdot 10^6$
Lower Eocene	$3.06 \cdot 10^6$

Model necessitates heat capacity values in $\text{J/ m}^3 \cdot \text{K}$, what is equal to W/m.K .

Table 5. Thermoconductivity for Lisi-Saburtalo district.

Name	heat capacity per unit volume
Upper Eocene	1.53
Middle Eocene	1.91
Lower Eocene	2

Table 6. Thermoconductivity for Central district.

Name	heat capacity per unit volume
Upper Eocene	1.75
Middle Eocene	1.86
Lower Eocene	2.09

Table 7. Thermoconductivity for Patardzeuli district.

Name	heat capacity per unit volume
Upper Eocene	1.3
Middle Eocene	1.56
Lower Eocene	1.9

Main source of heat in model is the thermal flow coming from the depth. In average it equals $-2500 \text{ J/m}^2 \cdot \text{day}$ (or 25 mWt/m^2). The minus in the software mean flow direction. Some literature data assumes it equal to 50 mWt/m^2 , though by calibration at real values of temperatures in wells software necessitates flow value equal to $32011 \text{ J/m}^2 \cdot \text{day}$. The second source of energy is source+/sink- of solid equal to $0.108 \text{ J/m}^3 \cdot \text{day}$ (or $1.25 \cdot 10^{-6} \text{ W/m}^3$). One more source of energy is constant temperature areas shown as blue points in the recharge area, where T equals 15. By the program request we enter also values of porosity of building rocks which is 0.25 for Upper Eocene and 0.14 for Lower Eocene.

Calibration

Model has been calibrated by comparing to piezometric map, which was build on the basis of closed wells data. Also, for calibration of temperature flow, the temperature distribution map was built, based on data from the same wells. According to above formulas, pressure and temperature depend on the same physical parameters; consequently they have been calibrated simultaneously by the variation of such parameters as coefficient of water yield, flow amount in recharge area and thermal conductivity. Water yield remained constant for each hydrothermal area during model verification because existing hydrodynamic information do not enable to propose how it may vary for different areas. Mean flow value also was set as constant.

Created model of pressure distribution was tested for real field data - data from open wells (Table 3). Values of hydrodynamic parameters providing best fit to model, assures that water yield coefficient at Lisi district is smaller than for Central district. It is worth to say that there are few data on pressure distribution on both sides of fault. Field measurement of well discharge data also do not allow to compute conductivity in the fault zone. This is why we set arbitrary as step, which corresponds to low conductivity.

Realization of digital modeling

The created model enables any type of simulation for investigated thermal area - balance evaluation, recognition of perspective areas, prognosis of well exploitation results, etc. At first, prognostic evaluation for Tbilisi deposit was carried out, assuming present conditions of exploitation, and thermal water balance for 10 years period has been computed. As it follows from Fig. 7., in future the subsidence of horizon is expected, in other words water pressures will decrease at all wells. Balance calculation shows energy loss from the thermal field boundaries and negative balance for the whole deposit.

Research workshop on Exploration and Exploitation of Groundwater and Thermal Water Systems in Georgia



Fig. 7. Variation of pressures for 10 year

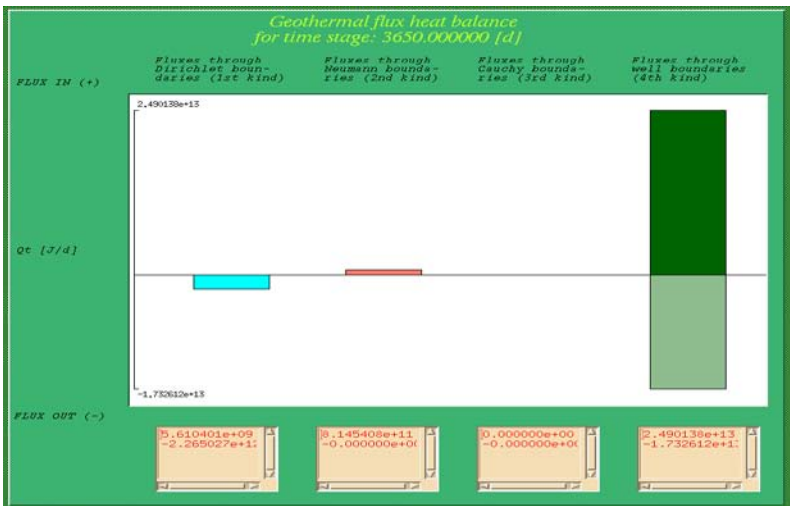

Fig. 8. Thermal balance for re-injection case during 10 years

At the next stage possible effect of exploitation, in case used thermal water will be re-injected back to the deposit was analyzed, i.e. in the case of

geothermal circulation at “Lisi” district. Namely, reinjection of hot water from well 5 to well 1 was simulated and its effect for 10 years period was calculated. In “Lisi” well water pressure decrease is moderate (comparing to previous situation) and there is some increase of water temperature in well # 5

Consequently total thermal balance for “Lisi” district, where reinjection was simulated, becomes positive.

Main results

As a result of modeling the 10 years perspective of thermal deposit of Tbilisi was assessed for present conditions of exploitation.

For example in the whole region subsidence of horizon is expected; only for Lisi district, if mean yearly discharge is preserved, pressure drops to 2-5 m and released thermal energy decreases from $5.5 \cdot 10^{20}$ to $1.578 \cdot 10^{17}$ J.

The case of geothermal circulation system was simulated by the software, when used water from well 5 (1690 m³/daily) at 300 °C is pumped back to the well 1 with negative level. In this case according to the model, ‘cooling of horizon and subsidence’ tendency become slower. Therefore, in future we recommend implementation of geothermal circulation system. This will help to achieve economical and ecologically stable exploitation of geothermal resources.

At the same time capabilities of digital modeling are not restricted by this. Exactly, if make detail model will be possible to select necessary regimes of exploitation of Samgori oil field, Lisi-Saburtalo and Central district to minimize their interdependence. It is possible to use model for selection of optimal areas for drilling new wells.

The authors acknowledge support of UNDP “Georgia-Promoting the Use of Renewable Energy Resource for Local Energy Supply”

References:

Buntebarth G., Kapanadze N., Kobzev G. and Melikadze G., “Re-assessment of the Geothermal Potential of Tbilisi region: The Hydrodynamic Digital Model Project”, “Environment and Recourses”, Association of Academics of Science in Asia Workshop, 25-27 September 2009, Izmir, Turkey, pp 154-161

Jimsheladze T, Kapanadze N, Melikadze G., “Microtemperature observation in Tbilisi seismoactiv region”, Journal of Georgian Geophysical Association, №12, 2008.

Sakvarelidze E., Glonti L., Melikadze G., Kobzev G., “Heat Field Modeling on the Example of Lisi-Saburtalo Area of Tbilisi Thermal Waters”, Institute of Geophysics Proceedings, Tbilisi №60, 2008, p.92-97

Sakvarelidze, E., Glonti , L., Research into Rocks’ Thermalphysic Characteristics by the Method of Impulse Flat Heat Source. Journal of the Georgian Geophysics Society. Solid Earth. 2008.

Sakvarelidze E., Glonti L., Melikadze G., “Temperatures Distribution Regularity on Interfaces of Water-bearing Complex Tbilisi’s Thermal Waters Deposit”, Mikheil Nodia Institute of Geophysics, Proceedings. 66-69, Tbilisi 2009

USING NUMERICAL MODELING FOR BORJOMI- BAKURIANI DRINKING WATER RESERVOIR

NATALIA ZHUKOVA

Mikheil Nodia Institute of Geophysics

GEORGE I. MELIKADZE, NADEZHDA DOVGAL

Institute of Earth Sciences, Ilia State University

The applied modelling considers mainly the interaction between surface water and groundwater of the Bakuriani-Borjomi lava flow and the possibility of their pollution with hydrocarbons in case of oil spilling. In order to define the possible pollution propagation, we apply slag-testing technology and numerical modelling methods.

Keywords: Surface and ground water, oil spilling.

Introduction

The Tbilisi-Baku-Ceykhan pipeline is of course very beneficial for the country of Georgia. At the same time even after its opening there are intensive discussions on the possibility of ecological catastrophe in the case of its damage (spilling) at some areas. One of such most complicated and extremely responsible sections lies within the geomorphologically dangerous Borjomi area, where the problem is connected with possible pollution of drinking groundwater source from lava layer at Bakuriani-Tsikhisjvari area by oil-products.

Conceptual model

Study area is located in the central part of Adjara -Trialety folded system on the plateau between the valleys of rivers Gudjaretis-Tskali and Borjomula, altitude 950-1450 m. The middle mountain erosive relief, created by river net, is complicated by various local micro-relief forms (erosion creeps). Volcanic activity in cretaceous provided the structuring of Daba-dzveli, Bakuriani and Gudjareti volcanic formation (Skhirtladze, 1958, Gabechava et al., 2000). And the latter two created long, narrow lava flows. The first one follows to the river bed reaching Borjomi, and the another one Tsagveri.

Model was built in MOFLOW package (Beradze et al., 1985). It was decided to divide the model into 5 layers (Chkhaidze et al., 1988). First upper layer is very thin and represents soil. Second layer simulates volcanogenic andesitic deposits (green layer in Fig. 1). Lava is added into the model as middle layer (light blue layer in Fig. 1). The lava takes place 180 m below the surface, within the early Quaternary alluvial sediments of the paleo-channel of the river Borjomula.

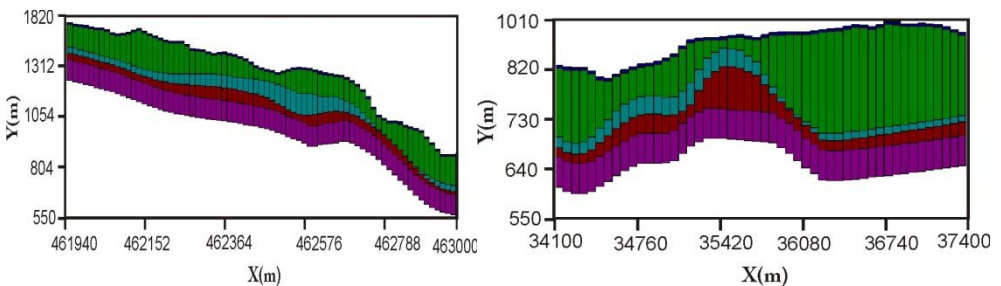

Fig. 1 Vertical and horizontal Borjomi model cross section

Tuff-breccia which forms Basin of Borjomula river and other waterways (river Gujaretistskhali) is represented by 4-rd layer in the model (red colour in Fig. 2).

Those zones in 4th layer which relates to the old riverbed are very high hydraulic conductible. The lower layer is an impermeable layer which represents flysh.

Layers change their form and thickness from North to South under consideration of available electromagnetic profiles.

In general hydrodynamic parameters of layers were found from available literature (Anderson et al., 1999, Meskhia et al., 2002, Chikhelidze et al., 1954). Hydraulic conductivities were estimated from the aquifer tests. See Table 1.

Table 1 Value of hydraulic parameters of layers

Layers	Specific Storage 1/m	Specific Yield unitless	Effective Porosity unitless	Total Porosity unitless	Hydraulic Conductivity m/s
1	7.1E-3	5E-1	2.53E-1	3E-1	2.1E-3
2	3.8E-3	1E-2	2.9E-1	3.5E-1	3.5E-4
3	3.8E-6	3.2E-4	4E-2	5E-2	1.5E-6
4	2.5E-3	1.4E-1	1.7E-1	2.5E-1	9.5E-4
5	8.5E-4	3.2E-3	8.5E-3	1E-2	2E-8

Precipitation occurs mostly on the plateau Bakuriani-Tsikhijvari and serves as the main source of model recharge. Participation in the recharge of lava plateau (the area between Sadgeri and Tsemi) occupies approximately 3-4 km².

Imposed on upper layer recharge boundary condition is not the same for the whole model. 40% of annual rainfall was assigned to the southern part of model area and 30% to the northern part.

Head –depended flow boundary (Cauchy) conditions were imposed along the Borjomula and Gijaretistskali rivers. No flow conditions were imposed along streamlines on the northern and southern (Bakuriani, Didi-Veli plateau) borders.

Springs were added as flow boundary condition. The elevations of springs as it emerged at the land surface were considered as head values. Impermeable flysh formed the lower boundary of a modeled system.

Numerical model

In the base of numerical model lies the Laplaces equation, which takes into account distribution of heads, hydraulic conductivities, storage

properties everywhere in the system and allows treatment of flow in three-dimensional profile (Beradze et al., 1985):

$$\frac{\partial}{\partial x} \left(K_x \frac{\partial h}{\partial x} \right) + \frac{\partial}{\partial y} \left(K_y \frac{\partial h}{\partial y} \right) + \frac{\partial}{\partial z} \left(K_z \frac{\partial h}{\partial z} \right) = S_s \frac{\partial h}{\partial t} - R$$

Where K_x , K_y and K_z are components of the hydraulic conductivity tensor. S_s is the specific storage, R is a general sink/source term that is intrinsically positive and defines the volume of inflow to the system per unit volume of aquifer per unit time. To simulate outflow $R=-W$. (where W is withdrawal rate).

Next step after conceptual model is model running. After, successful first run model calibration has been carried out.

Aim of model calibration was to minimize difference between the simulated and observed water levels. Model has been calibrated in a steady-state mode by head and deuterium observation data. Head data were collected on the rivers Borjomula and Gujaretistskali, in Daba and Tba boreholes during 2 years. Together with head observation isotope data (deuterium observation) were used. Deuterium data showed different values for Bakuriani and Borjomi regions, what gave possibility of using deuterium for improving calibration process. Deuterium samples from Borjomula river, Tba, Sadgeri, Borjomi park were added into model as concentration observation points. The concentration was added into model by using particles tracking package (Modflow package's part). Each particle represents mass of concentration, which is transported by groundwater flow.

Calibration residuals were calculated by subtracting the head and concentration observed values measured at observation points from the values calculated by the model at those points. The value of the calibration residual represents a quantitative measure of the "goodness-of-fit" between the simulation results and the 'known' or observed conditions of the system. Goodness-of-fit satisfies (discrepancy 1.8%, required <2%) the

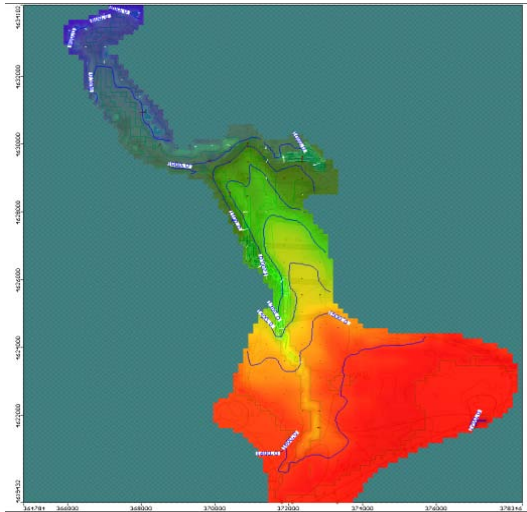

Fig. 2 Model of water table elevation

minimal requirements of calibration, but is not perfect. Additional head observation can decrease calculation error.

Inflow balance in Fig. 2 shows that that river contribution to the groundwater system does not prevail over to recharge from precipitation and the system assumes deeper water circulation.

Conclusions

Three flow path ways inside and under lava were determined by the model.

After infiltration in lava sheet “spring water” flows along ancient river valley in Quaternary alluvial and are discharging as Sadgeri and Daba springs.

Water flows along breccia rocks and that is why their pathway to surface is longer than the route of waters flowing to rivers. By numerical modelling: it reveals the difference between durations of water flow for above two pathways, equal from 70 to 30 days;

1st stream flowing coincides with old river bed in breccia's rocks. This stream has direction on the western site of lava stream and passes area near Tba borehole and runs up to Sadgeri springs. For reaching from recharge area to the Tba borehole approximately 30 days are supposed, 80 days are necessary to reach Sadgeri springs. 2nd stream found path on the right eastern site of lava and takes more days (about 70) to run up to the central part of Lava body near Tba village (red-brown segment of path line).

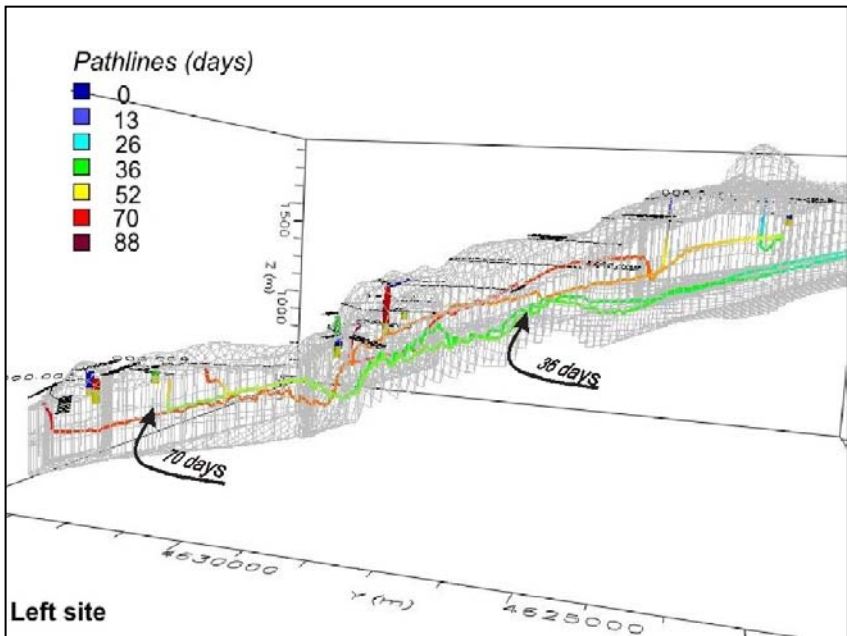

a

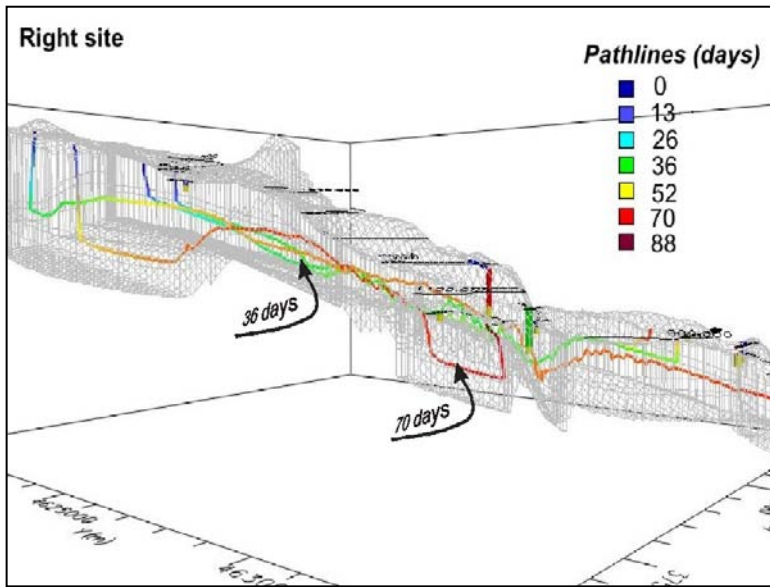

b

Fig. 5 Vertical view of movement (a) Vertical direction of particles' movement from the left site of model is shown; (b) Vertical direction of particles' movement from the right site of model is shown

Flowing from recharge area to the central part of area not along old riverbed takes more time (about 50 days). 26 days of flowing is marked by blue colour of line. It means that contaminant could reach central area where Tba and other boreholes are located at least in 26 days.

Thus, the possibility that oil contaminant in the case of pipeline accident can reach mineral water sources is realistic.

References

- Skhirtladze N.** 1958: After Paleogen effusive in Georgia (in Russian)
- Gabechava J.** et al., 2000, "Study of water regime of Daba spring (Borjomi district), Geological report, Georgian Glass and Mineral water Co.

Beradze R. et al. 1985: Report on 1:25 000 scale geological prospecting K- 38-75-b-v-g and K—38-75-G -a-b (in Russian), Georgian Geological department.

Chkhaidze D. et al. 1988: Report on 1:25 000 scale special hydrogeological prospecting works on the borjomi mineral water resources, Georgian Geological department. (in Russian)

Anderson M. P., Woessner W. W. 1999: Applied Groundwater modelling, Academic Press, New York.

Meskhia A. et al., 2002, Geophysical investigations for groundwater study nearby Daba village in Borjomi region, Georgian Glass and Mineral water Co.

Chikhelidze S., 1954, Hydrogeology of Sadgeri spring, Geological report, Georgian Geological department.

Research workshop on Exploration and Exploitation of Groundwater and Thermal Water Systems in Georgia