



TU Clausthal

Clausthal University of Technology

Developing a power supply solution for a mobile robot

Carsten Gieseemann, Günter Kemnitz

IfI Technical Report Series

IfI-10-03



IfI



Department of Informatics
Clausthal University of Technology

Impressum

Publisher: Institut für Informatik, Technische Universität Clausthal
Julius-Albert Str. 4, 38678 Clausthal-Zellerfeld, Germany

Editor of the series: Jürgen Dix

Technical editor: Michael Köster

Contact: michael.koester@tu-clausthal.de

URL: <http://www.in.tu-clausthal.de/forschung/technical-reports/>

ISSN: 1860-8477

The IfI Review Board

Prof. Dr. Jürgen Dix (Theoretical Computer Science/Computational Intelligence)

Prof. i.R. Dr. Klaus Ecker (Applied Computer Science)

Prof. Dr. Sven Hartmann (Databases and Information Systems)

Prof. i.R. Dr. Gerhard R. Joubert (Practical Computer Science)

apl. Prof. Dr. Günter Kemnitz (Hardware and Robotics)

Prof. i.R. Dr. Ingbert Kupka (Theoretical Computer Science)

Prof. i.R. Dr. Wilfried Lex (Mathematical Foundations of Computer Science)

Prof. Dr. Jörg Müller (Business Information Technology)

Prof. Dr. Niels Pinkwart (Business Information Technology)

Prof. Dr. Andreas Rausch (Software Systems Engineering)

apl. Prof. Dr. Matthias Reuter (Modeling and Simulation)

Prof. Dr. Harald Richter (Technical Informatics and Computer Systems)

Prof. Dr. Gabriel Zachmann (Computer Graphics)

Prof. Dr. Christian Siemers (Embedded Systems)

PD. Dr. habil. Wojciech Jamroga (Theoretical Computer Science)

Dr. Michaela Huhn (Theoretical Foundations of Computer Science)

Developing a power supply solution for a mobile robot

Carsten Giesemann, Günter Kemnitz

Department of Informatics, Clausthal University of Technology,
38678 Clausthal-Zellerfeld, Germany, <http://techwww.in.tu-clausthal.de>

Abstract

The article describes the power supply design of a mobile robot. Starting with the specification of the requirements it describes two preliminary designs with an integrated dual-voltage switching power regulator circuit, producing disrupted output voltages, and the final successful design. The aim of the article is to highlight some aspects of the winding way of today's electronic design processes.

Keywords: power supply, mobile robot, switching power regulator

1 Introduction

For our humanoid robots – type ROBONOVA [3] – extended by a new FPGA based hardware a new power supply had to be designed. The whole project is named HuBoTUC (humanoid robots of technical university of claustral) [2]. As a suitable Li-Ion accumulator the Samsung L18650 was found having a capacity of 2700 mAh and a nominal voltage of 3.7 V [5]. The servos have a supply voltage range from 4.8 V to 6.0 V, so two accumulators have to be connected in series. The resulting 7.4 V has to be transferred to 6.0 V for the servos. In addition the FPGA and the rest of the control circuitry need the following voltages: 5.0 V (≈ 100 mA), 3.3 V (≈ 500 mA), 2.5 V (≈ 10 mA) and 1.2 V (≈ 200 mA). The space for the power supply circuitry is very limited (only few cm³). Wanted operation time is two hours or longer.

Due to the fact that the 16 servos have a peak current consumption up to some amperes and the considerable consumption of the 3.3 V voltage, mainly for the SRAM circuits, no space for cooling devices and the desired long operation time – fixed voltage regulators are unsuitable. We decided to use two switched voltage regulators for the high current voltages 6.0 V and 3.3 V and fixed voltage regulators for the rest. After some internet research the National Semiconductor LM26400Y dual 2 A 500 kHz wide input range

buck regulator was chosen [6]. It is a very small step-down regulator capable to provide the two high current voltages. However, after two unsuccessful attempts a different astonishing simple solution was found and chosen.

2 The first design

Since the robot and its control unit were still under design, the first power supply has been designed for another FPGA board, needing four off-board supply voltages: VCCINT (1.2 V), VCCIO (3.3 V), VCCAUX (2.5 V) and 5.0 V. The switching power regulator has been used for VCCINT (1.2 V) instead of the 6.0 V, while the VCCIO (3.3 V) remained on the other output. The additional voltages had to be generated by some fixed voltage regulators, the VCCAUX (2.5 V) by a LM317 L from National Semiconductor [7] and the 5.0 V by a ZLDO500, an ultra low dropout fixed voltage regulator from Zetex Semiconductor [4]. The printed circuit board was designed using EAGLE [1]. Figure 1 shows the circuit diagram from the schematic editor. It is obvious that the switching power regulator has a more complex circuit than the fixed voltage power regulators with 2-3 capacitors and – if adjustable – two resistors. All the circuits and the values of the components are taken from the corresponding datasheets [4, 6, 7]. The PCB (Printed Circuit Board) was self-manufactured using photo sensitive basis material, chemical etching and through-plating by rivets. The assembling was also hand-made, using a sol-

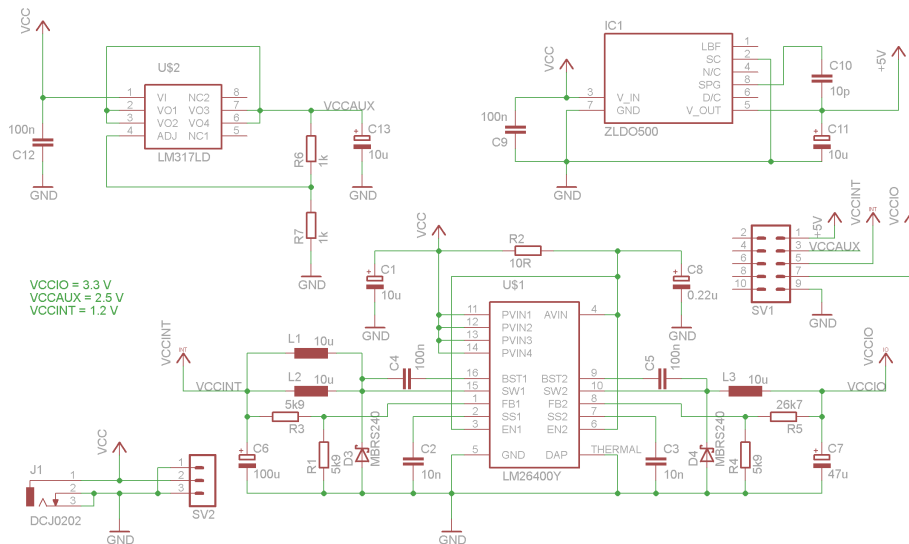

Figure 1: Schematic of the first design

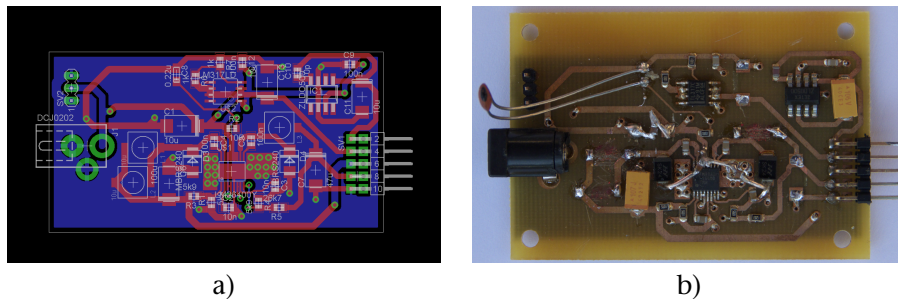

Figure 2: a) Board design (the LM26400Y is on the bottom, the LM317LD and ZLDO500 are on the top) b) Assembled board with additional capacitors, improved wiring to reduce inductance of critical connections etc.

dering oven for the SMD (Surface-Mounted Device) components (fig. 2).

After the continuity check and the elimination of the shorts and breaks, the board was put into operation using a laboratory power supply. Both fixed voltage regulators worked fine and will not receive further consideration. The LM26400Y produced both of the desired voltages, but with an overlaying disruption, making them unusable. The oscillograph curve showed that the disruptions were caused by the 500 kHz switching frequency of the regulator. Deducing from [11], reducing of the inductance of critical wires, increasing the load and/or increasing capacitors could solve the problem. A load increase had no positive effect. An astonishing side effect was that the high frequency dirt was even measurable on the ground connection. Additional $2,2 \mu\text{F}$ ceramic capacitors close to the regulator reduced the disruption slightly. Huge electrolytic capacitors around the regulator had no positive effect, confirming only that the problem cannot be solved in this way. Also critical wires had been shortened as far as possible (fig. 2 b). Assuming that the wiring caused the problem, the board was redesigned.

3 The second design

This time the board layout example from the datasheet [6] shown in fig. 3 a was adapted, having much shorter critical wires but requiring much more PCB-area. The schematic design remained the same as in fig. 1. The modified PCB is shown in fig. 3 b and c. This board was also an in-house production. After successful continuity check it was put into operation again with a laboratory power supply.

As in the first design the linear power regulators works flawless and stable even under high current load. What about the LM26400Y? Little progress was made. The output voltages are better, but still not clean enough. Trying

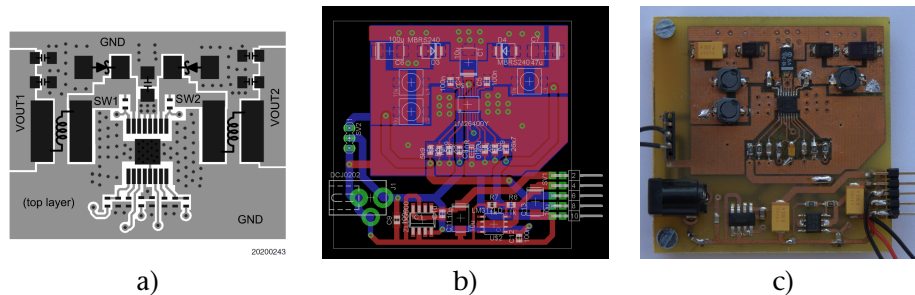

Figure 3: a) Example layout from the data sheet b) PCB layout c) assembled board

the same workarounds as before – high load, additional capacitors etc. – the output voltages did not turn flat. A disappointing result, which leaves two open questions:

1. Does the LM26400Y need special components for its circuit?
2. Are our hand-made and manufactured PCBs the problem?

In the data sheet of the LM26400Y [6] not only the values of the components are listed but also part numbers of certain component companies. This is a strong evidence that the first guess is right. On the other hand, our PCBs are far from being manufactured professionally. For example, rivets for through-plating were used, which could also cause high frequency problems. Maybe it is a mixture of both problems. Our simulation and test facilities did not allow a closer localization.

How to go on? Engineering is a creative art. Failures are necessary to learn. It was a »successful failure« like the unsuccessful Apollo 13 mission, where a technical failure prevented the landing on the moon. The astronauts returned safe to earth and the technicians learned how to avoid trouble in future. In our case we learned that we cannot handle a high frequency switched voltage regulator design with our facilities and have to look for a different solution.

4 The final design

As it is often the case, the solution was right in front on the laboratory desk all the time in form of a Spartan-3A DSP Starter Board, having a similar power supply as the one to be designed [10]. This board has switched power regulators, however, not assembled of single components, but using two Texas Instruments PTH switching regulator modules. These modules are available

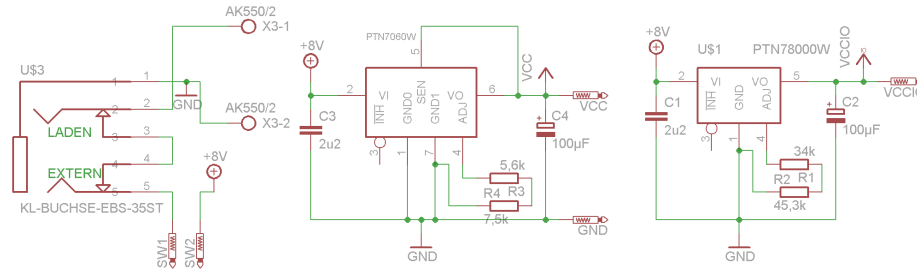

Figure 4: Schematic of the final design

for different current ratings, but not for the input voltage of our Li-Ion accumulator package. Fortunately, there are similar modules with wide input voltage ranges, named PTN series. Only one resistor is necessary for setting the output voltage. In addition two capacitors are required – a very simple solution (fig. 4).

The robot requirements were back in focus. As mentioned earlier, it needs several voltages. The decision was made to test the 3.0 A module PTN78060W to produce the 6.0 V servo voltage and the 1.5 A module PTN78000W to produce the 3.3 V I/O voltage [8, 9]. The other voltages are still produced by linear power regulators since the loads are small. Of both modules Texas Instruments send us a free engineering sample, many thanks for it.

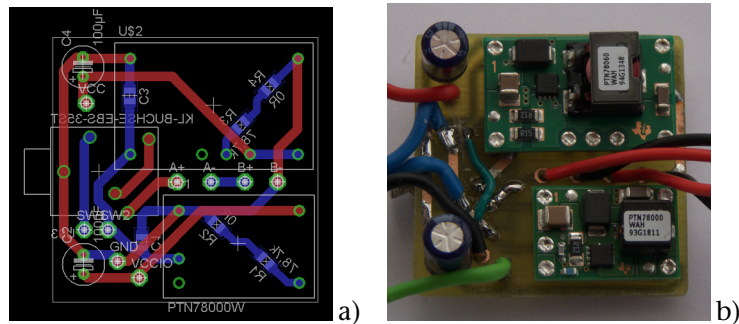

Figure 5: Final design a) board layout b) assembled board

These modules have the perfect shape to fit into the body of the robot, so we decided to design the PCB in the right size to find place under the Li-Ion accumulator. The circuit on the PCB consists beside the voltage modules of two resistors in a row due to higher precision and two capacitors per module corresponding to the data sheet. A jack plug for charging the accumulator and powering the robot from an external source is also added. The on-off switch will later find its place on the control unit of the robot, so it is only

on flying wires here. All in all the robot control unit and the power supply unit are connected by five cables. Two cables go to the on-off switch. The other three are the two power rails and the ground rail (fig. 5). The linear voltage regulators are on the robot PCB too. Testing showed that all voltages are clean and stable for the whole load range. After some final adjustments of the layout the boards are finally manufactured and work fine. Figure 6 shows, how the accumulator pack and the designed PCB are mounted within the robot.

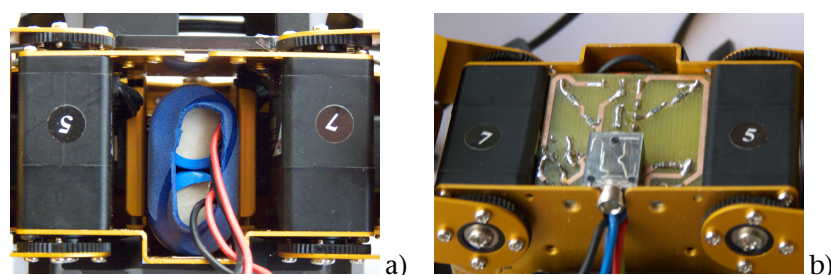

Figure 6: Power supply mounted in the robot a) accumulator double pack b) PCB covering the accumulator

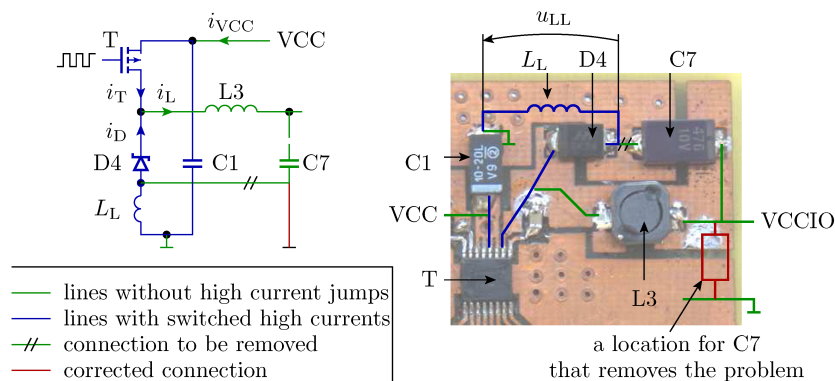

Figure 7: Circuitry, responsible for the unwanted spikes

5 Lessons learned

Figure 8 shows the waveform of the voltage at the 3.3 V output. There is the normal small ramping caused by the cyclic increase and decrease of the cur-

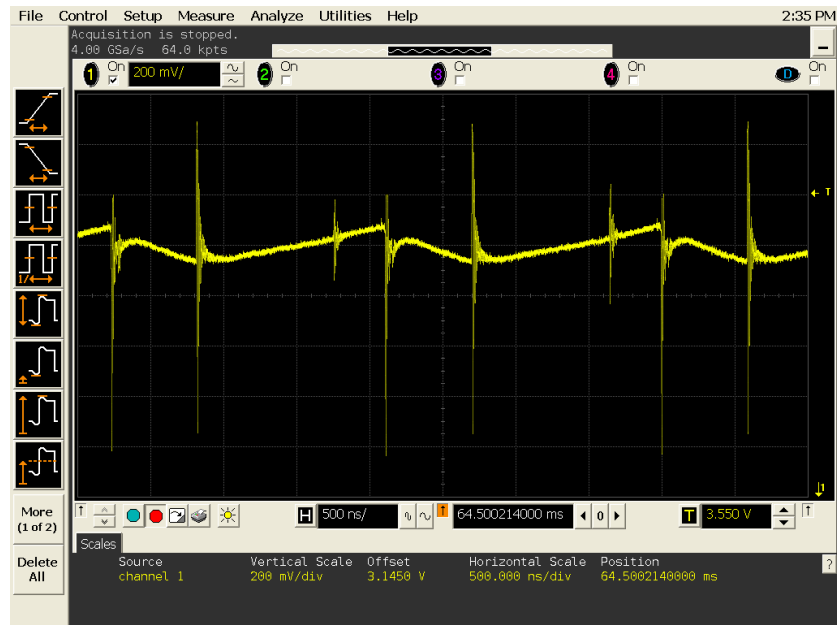

Figure 8: The disturbed voltage at the 3.3V output

rent through the inductance superposed by spikes of approximately 500 mV at the begin of each ramp.

Obviously the switching of the voltage regulator is responsible for the overlapping spikes. The part of the circuit diagram with the switched high currents is shown in fig. 7. It consists of the switching transistor T within the voltage regulator, the catch diode D4 and the input capacitor C1. The other currents – the one from the input power supply and the one through the inductance – are without high switched currents so are probably not the cause of the spikes.

When the transistor switches on, i_T approximately rises from zero to more than 1 A within few nanoseconds. Simultaneously the current i_D reduces to zero. When the transistor switches off, i_T turns to zero causing a jump of i_D by the same amount. The rise or fall of the current is so fast, that over the small inductances of the wiring with a fast oscilloscope the voltage drops can be measured, especially over the inductance L_L parallel to the catch diode D. Figure 9 shows the oscillogram.

And then the problem became obvious. The output capacitor C_2 is connected close to the anode of the catch diode, which leads to the circuit diagram in fig. 7 with output capacitor C_2 in series with the wiring inductance L_L . Thus the output voltage is superposed by u_{LL} . To check the assumption

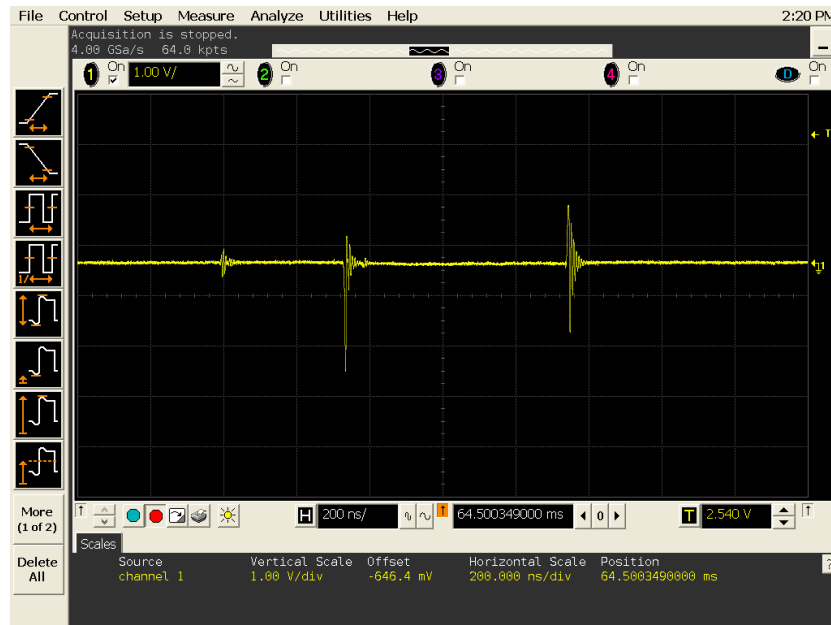
Figure 9: The voltage u_{LL}

we rearranged the output capacitor as indicated in fig. 7. As shown in fig. 10, the rearrangement of the capacitor almost solved the problem.

6 Conclusions

Electronic design has its own philosophy. In contrast to software one cannot simply design a circuit from components that works at once, especially a high frequency analog circuit. Sometimes, it is better to abandon an own solution and look for alternatives. Maybe it is – as here – right on the desk and needs only to be discovered.

References

- [1] EAGLE website. <http://www.cadsoft.de/>.
- [2] HuBoTUC website.
<http://techwww.in.tu-clausthal.de/site/Projekte/HuBoTUC/>.
- [3] Robonova website. <http://www.robonova.com/>.

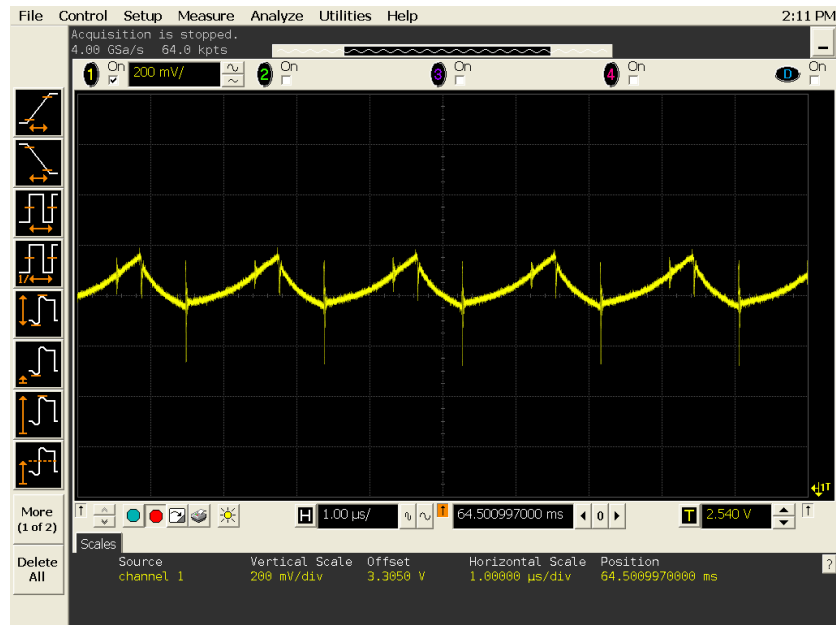

Figure 10: The voltage after rearranging C_2 measured over C_2

- [4] ZLDO500 5.0 volt ultra low dropout regulator. <http://www.diodes.com/>, 1997.
- [5] L18650 data sheet. http://www2.produktinfo.conrad.com/datenblaetter/250000-274999/251024-da-01-en-LI_ION_Akku_Samsung_L18650.pdf, 2006.
- [6] LM26400Y Dual 2A, 500kHz Wide Input Range Buck Regulator. <http://www.national.com/>, 2007.
- [7] LM317L 3-Terminal Adjustable Regulator. <http://www.national.com/>, 2008.
- [8] PTN78000W, PTN78000H 1.5-A, wide-input adjustable switching regulator. <http://www.ti.com/>, 2008.
- [9] PTN78060W, PTN78060H 3-A, wide-input adjustable switching regulator. <http://www.ti.com/>, 2009.
- [10] Spartan-3A DSP Starter, Platform User Guide. <http://www.xilinx.com/>, 2009.
- [11] Günter Kemnitz. *Technische Informatik 1: Elektronik*. Springer, 2010.