

DETC2018-85805

INTEGRATING INTELLIGENCE AND KNOWLEDGE OF HUMAN FACTORS TO FACILITATE COLLABORATION IN MANUFACTURING

Harley Oliff
School of Engineering
Cardiff University
Cardiff, UK

Ying Liu
School of Engineering
Cardiff University
Cardiff, UK

Maneesh Kumar
Cardiff Business School
Cardiff University
Cardiff, UK

Michael Williams
Olympus Surgical Technologies
Europe
Cardiff, UK

ABSTRACT

The implementation of automation has become a common occurrence in recent years, and automated robotic systems are actively used in many manufacturing processes. However, fully automated manufacturing systems are far less common, and human operators remain prevalent. The resulting scenario is one where human and robotic operators work in close proximity, and directly affect the behavior of one another. Conversely to their robotic counterparts, human beings do not share the same level of repeatability or accuracy, and as such can be a source of uncertainty in such processes.

Concurrently, the emergence of intelligent manufacturing has presented opportunities for adaptability within robotic control. This work examines relevant human factors and develops a learning model to examine how to utilize this knowledge and provide appropriate adaptability to robotic elements, with the intention of improving collaborative interaction with human colleagues, and optimized performance. The work is supported by an example case-study, which explores the application of such a control system, and its performance in a real-world production scenario.

INTRODUCTION

For several decades, the field of automation has been the focus of intense development and the presence of automated robotic systems within the manufacturing industry has become ubiquitous [1]. Despite this, the human component of these manufacturing systems persists, as some tasks remain to

dexterous or varied for robotic operators to perform. As such, these robotic operators are consistently employed to perform tasks with human operators as colleagues, which introduces variation and uncertainty into the process; as human beings are subject to the influence of a great many factors, which affect their performance in a number of ways. This work is intended to assess the feasibility of utilizing concepts of intelligent manufacturing to provide the necessary adaptability required to collaborate with human colleagues. Alongside the developments in automation, developmental advances in computer science have enabled increasingly advanced and capable systems, the capabilities of which are only just beginning to be realized and implemented. Crucial to the effectiveness of these advanced computational systems is the generation and utilization of data, which provides the crucial information that enables such systems to exhibit intelligent behaviours. The concept of intelligent manufacturing exists as a field of study in its own right, and a vast amount of work is being done to develop these capabilities. The application of intelligence has led to the development of cyber-physical systems [2], which combine computational and physical processes such that the embedded computers can autonomously predict and control processes, through manipulation at the physical level. Using a level of computational intelligence to act autonomously, and by utilizing available data, these systems are capable of building conceptual models to enable: self-awareness & prediction; [3]; self-configuration [4]; and self-optimization [5]. These self-x factors are capabilities of such systems, and all of which contribute to

achieving higher levels of adaptability; efficiency; functionality; reliability; safety; and usability [6].

Decentralization of control is the common factor enabling many of these self-x capabilities. centralized control architectures employ a hierarchical structure, which presents problems achieving adaptability and autonomy, as production processes become increasingly complex. [7, 8]. the distribution of computing reduces system complexity, by dividing the control problem down into multiple tasks distributed to a number of agents. Decentralization additionally facilitates collaborative interaction. By providing robotic entities with agency and embodying these agents with their own intelligence they may act independently and autonomously with neighbours to achieve a common goal [9, 10]. This embodiment, present additional benefits for Human-Machine-Interaction, as it influences the way agents interact, due to the unique nature of each agent's cumulative experience. It enables agents with the same control structure to be more adaptable, and better select appropriate behaviours for multiple situations, as their responses are based on their own experiences. [11, 12].

The application of intelligence in a decentralized fashion necessitates interaction and collaboration between entities, each of which must align its own actions with others to achieve a common goal. Facilitating collaborative behavior has been a key aim of robotics research for several years, and many examples of robots capable of engaging in collaborative behaviours exist. Such robots are however typically employed in direct, physically oriented applications. Robots capable of learning patterns in motion and forces have been applied to a number of handling and manufacturing tasks.

Applications include handling of large and unwieldy components [13], autonomous replication of advanced manufacturing processes, such as composite layup, oversize component handling, and welding fabrication, and facilitating safety when active in a shared workspace [14-18]. Adaptable behavior enabled by the learning mechanisms combines the flexibility and reconfigurability of humans with the strength, accuracy, and repeatability of their robotic counterparts.

Such approaches demonstrate the feasibility of using a learning approach to account for human variability, however, limited work exists on how to best leverage intelligence when considering other human factors.

Recent application of *intelligent* agents, make use of machine learning to automate the agent's constituent control and analytical systems [19] and often employ neural networks to control the decision-making processes.

Neural networks have been successfully implemented in a number of applications and provide a non-deterministic method of matching a number of input variables to an output, and for approximating relationships between multidimensional data. Their recent successes owing to capacity for analytics and pattern recognition; the ability to be abstracted and manage a large number of data inputs; and their adaptability to suit a wide variety of applications.

Recent developments have resulted in a wide range of network structures. Recurrent networks include consideration of

temporal patterns, and are used to process time-series data for pattern recognition; convolutional networks introduce multiple layers of abstractions and have been applied successfully to a number of vision-based learning and recognition tasks; and deep reinforcement learning is used to produce optimal policy generation based on simulation and experience [20-22]. A thorough study on the topic can be found in [23-25].

The utilization of neural networks as a learning model overlaps significantly with the field of cognitive computing a branch of computer science focused on replicating thought processes as they occur in the human brain. Typically, this is through the utilization of combinations of neural networks, to replicate cognitive processes [26, 27].

This has potential implications for the facilitation of collaborative behaviour and the improvement of human-machine-interaction. Recent work on social cognition and social intelligence suggests that providing intelligent robots with social understanding, and human-like cognitive processes and structures, will better enable natural and intuitive behavior when interacting with humans [28, 29]

Attempts to replicate *cognitive* processes are frequently developed into cognitive architectures, which define the structure of control systems which enable intelligent behaviour. These architectures frequently include a modularized structure, with multiple interacting separate elements responsible for different aspects of cognition, analogous to the multiple lobes and their unique structures that form the human brain [27]. Such a structure facilitates the integration of low-level perceptual and motor control systems with higher-level knowledge extraction and decision-making processes [30]. Examples of such architectures include ACT [31], SOAR [32], and particularly, C4 [33]. Multiple frameworks and research areas exist to best implement intelligent computational features to achieve a level of *cognition*, although there is little consensus and a wide variance in their application and capability. Additionally, many unresolved problems remain to be overcome, for effective integration and use of such methodologies, including reconciliation of data-semantics, connectivity, and security.

Work in the field of intelligent manufacturing has led to the consideration of decentralization and the utilization of intelligence to improve manufacturing processes. These concepts enable adaptability through a reduction in the system complexity, and additionally, facilitates collaborative interactions, by necessitating the coordination of robotic entities to achieve common goals.

Developing robotic systems capable of adaptable behavior can potentially mitigate the effects of the variation in performance of human beings and facilitate collaborative interactions. Consideration of the impact of human factors may be used to account for performance variations, and learning can be leveraged to provide the decentralized agents with the capacity to intelligently analyze and respond appropriately to contextual information.

The following section presents a meta-analysis of existing literature on the study of human factors and their influence on

task performance. Human factors and their influence on performance has been studied for decades and is frequently applied from a management perspective, but its application to the field of robotics and collaboration is an area of little enthusiasm.

META-ANALYSIS OF HUMAN FACTORS INFLUENCE ON TASK PERFORMANCE

Unlike their robotic counterparts, (designed with intent not to be afflicted by any of these factors) a multitude of factors exist which may affect human performance. Typically expressed through the lack of repeatability and accuracy, Human Operators are often sources of significant disruption to a system. This extends the variation between different human operators, as the aforementioned factors influence behavior and prevent consistent human performance for the task duration. Significant research has been conducted over the past century, from a human-factors perspective, to investigate and model the influence of these factors on human operators, in the manufacturing context:

Type of Task: Perhaps the most noteworthy and biggest source of human performance variability is the demands and nature of the task being performed. Work by NASA resulted in the development of a framework which identified a number of task structures, each requiring differing combinations of physical and mental cognitive loading, and assessed how each type influences the relative impact of a number of factors associated with perceived workload. These *task demand characteristics* will influence the way in which a number of factors, such as the task duration, and frustration with the task, may influence workload and ultimately performance. [34, 35]. Assembly tasks typically combine mental and physical demands, requiring manual and dexterous manipulation of components. As such, they are influenced heavily by fatigue, which, in turn, influence the performance of the task.

Fatigue: Of all elements considered by Human Factors studies, more attention has been turned to the effects and causation of fatigue than any other. Fatigue is commonly understood to exist in two distinct types: Physical, or motor fatigue, involving fatigue of the muscle; and cognitive, or mental fatigue a fatigue of the brain, resulting in the deterioration of cognitive functions [36]. The two types also do not occur independently. Work has found links between motor fatigue and increased nervous loading, resulting in poorer response times in decision-making tests, and a simultaneous decrease in motor control and physical function [37]; suggesting that dexterity may be detrimentally affected by cognitive loading.

Fatigue is a well-studied concept, and is typically the result of two factors: The required amount of effort or load, and the *time-on-task*, a measure of the cumulative effects of repetitive task performance [38]; additional factors, including the interstitial period of rest and their duration, further affect the fatiguing mechanism. [39].

Time; Fatigue also more typically refers to feelings of tiredness and arises as a result of sleep deprivation. The effect of this is clearly notable, and a number of studies have demonstrated the immediate and cumulative effects of sleep deprivation on performance [40, 41]. Sleep is a complex phenomenon, governed by, and serving a large number of physiological processes. Breaks between physical exertions can serve to recover the capability of the muscle, leading theories suggest that sleep is analogous to this period of recovery for mental fatigue. Performance can also be linked to the natural circadian rhythms and is expressed through notable changes in performance dependent on the time of day, with performance increases often seen as the working day progresses [42]. Patterns in human circadian rhythms are known as *chronotypes*, and are typically expressed in terms of increased motivation and task performance either in the morning (larks) or at night (owls); with subsequent decreases when performing a task at a non-preferential time of day [43]. Other work has demonstrated the existence of an observable *day-of-the-week* effect, with decreased performance on Mondays, rising through the week to optimal performance on Thursdays [44].

Skill Level/Experience; Learning, and the study of how human beings learn and adapt is a well-studied and yet frequently misunderstood phenomenon. The most widely accepted is the *Learning Curve*; the result of experiments in which time taken to complete a task, was measured for a number of repetitions, to represent the decrease in time taken to perform a task with practice. Or, when reversed, represents how proficiency increases with time spent performing that task. This curve is well known and is obviously non-linear. The concept of unit production cost falling with accumulated experience is well studied, and the rate of improvement will vary between individuals [45].

Environment; Environmental conditions are well studied, and were some of the earliest factors considered to affect performance and productivity; with many factors having a noticeable impact. There are a wide variety of environmental factors that may contribute; Frequently, environmental factors are not found to influence primary task performance, but will often limit the ability to perform concurrent tasks requiring an additional allocation of attention [46]. Variations in Temperature Light Levels and Noise can all influence task performance if not consistent, or maintained to the appropriate level.

Emotional State; The impact of emotional state on work performance is an understood, albeit yet largely ignored factor when applied to work performance. Recent work on enabling social cognition aims to predict emotional states from the observation of actions and behaviours. The notable mention when considering emotional states goes to the impacts of *stress*, one of the best studied of the human emotional phenomena in this context. Stress and its effects are well studied [47] and are consistently found to have a significant detrimental impact on performance. Stress is closely related to frustration, a task

demand characteristic that is a leading factor in the perceived workload of a task [34]; tasks that lead to increased frustration propagate additional stress, compounding the detrimental effects on performance.

Satiety & Caffeine; The link between performance and food intake is perhaps one of the most interesting. The biological actions and reactions to the complex mechanisms of hunger include both the physiological and cognitive domains [48, 49]. Study on the effects of satiety on both cognitive and motor performance suggest that food intake typically decreases performance in tasks requiring high cognitive loading.

The following section presents our work on establishing whether the application of *intelligence* can alleviate the problems associated with human involvement in the manufacturing process. Theory suggests that cognitively inspired approaches are suited to providing adaptability, which is required to overcome the variability in behavior of human beings. The approach is hypothesized to improve collaborative behavior between the robotic and human elements, by enabling the robotic operator to alter its behavior based on its knowledge of its human counterpart, and its observed information.

LEARNING MODEL FOR HUMAN PERFORMANCE PREDICTION

From the existing work, there is an opportunity to reconcile several domains, and to leverage the underutilized knowledge from the human factors field, to improve the collaborative behavior of Robotic Operators (RO's) within the manufacturing context. Our approach focuses on providing an awareness of human factors within a control system to provide a degree of context. Additionally, the utilization of learning techniques to establish relationships between human operator behaviour and the contextual human factors will enable patterns to be predicted and appropriate variations in robotic behaviour implemented.

Variability in human performance is a source of uncertainty in the system and can lead to bottlenecking or lagging occurring in such human-machine-interactions if behaviours remain static and independent of one another. The idle time of both the human and robotic components has been used as an objective measure of fluency in collaborative tasks, and Human Machine interactions often display poor fluency in *fetch and-deliver* type tasks, whereby the robotic elements are required to provide their human counterparts with an object [50].

Human beings are inconsistent creatures, and as such, any human-generated data is likely to be noisy, and the theoretical influence of these factors may vary significantly between individuals if present at all. Mapping the influence of these factors at the system level would be an arduous and unnecessarily complex task. By providing the robotic operators with agency and utilising the benefits of a Neural Network learning model to approximate these mappings. These approximations may be learned from individual operator working patterns.

As previously discussed, the aim of the work is to apply techniques of machine learning to inform decision making based on observed and previously experienced data focused on human factors, and to integrate it with a control mechanism which can be used to influence robotic behaviour. Doing so requires two areas of development. Firstly, a simulation is developed to replicate a generalized interaction scenario typical of a manufacturing process, to serve as an isolated and controlled testing environment, enabling evaluation to take place in an isolated without any real-world implications for error. The use of simulation has considerable benefits over a full experimental implementation. Iterative updates are much easier to implement, and a wide variety of scenarios and parameters can be evaluated and accounted for.

Secondly, the learning element is developed as separate Java code, which is then integrated with the simulation environment via function calls. Such a setup is inspired by the modular nature of established cognitive architectures. Two simulated experiments are then conducted, one in which the behaviour of the robotic operator remains static, to provide a control case; and another in which the behaviour of the robotic operator is determined by the predictive neural network. The following two sub-sections further detail each of these two areas.

Simulation Development

The simulation design replicates a common production line scenario consisting of subsequent assembly steps, focusing on the collaborative interactions between a single RO and a Human Operator (HO), working to achieve the common goal of assembling the product.

The interaction examines the interaction in a generalized manner, considering between an upstream and downstream position, and a non-specific manufacturing operation defined only by its duration at each position. The two operators are separated by a conveyor that doubles as a buffer zone. This arrangement and the accompanying simulation model is illustrated in Figure.1. Such an interaction also bears similarity to fetch-and-deliver type interactions, where one agent must provide the other with an object for them to perform their task.

The simulation was developed using AnyLogic, a Java Based simulation platform designed for Agent-based, Discrete Event and System Dynamics simulation approaches. This combined functionality, and the ease of integration with external Java Libraries, best suited the applications of this work.

Whilst the simulation environment primarily functions as a platform to evaluate *on-task* robotic performance, it is also used to generate data for training the learning algorithms. The human component of the simulation is parameterized to replicate the performance of three different operators and modelling the effect of multiple identified human factors on their performance. A number of these human factors relating to fatigue are considered, as this has been shown to greatly influence human task performance.

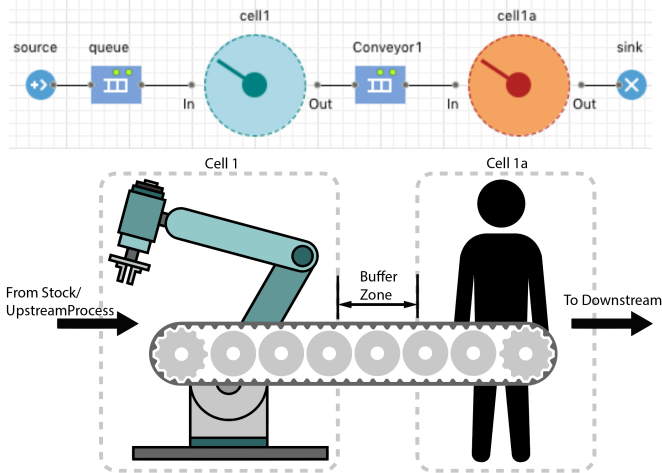

FIGURE.1. THE MODEL DEVELOPED IN ANYLOGIC, EACH CELL CONTAINS A DELAY AND DATA CAPTURE ELEMENTS.

The Task Duration, in this scenario, the *Shift Duration (SD)*, was monitored and used to influence the performance, represented in the task as the Cycle Time (CT), or duration spent performing their assembly sub-task on each product. The Cycle Time was successively increased representing the decreased performance associated with the effects of fatigue. A *Shift Modifier* was also included, to account for the improved performance observed in afternoon shifts; this value is set to 1.0 for the am shift, 0.95 for the midday shift, and 0.9, representing no influence for the pm shift. Additionally, each simulation run was modified by a *Weekday Modifier*, to reproduce the effects that weekday variation has on performance. The effects of cumulative experience were considered, and may be useful when working with new staff, however, will be redundant once the Human Operator reaches a level of capability with the task. Environmental variables and the effects of satiety and caffeine intake were also not considered, as they were deemed the easiest to keep consistent.

The relevant parameters used for each operator can be seen in Table.1. These values reflect the operator’s susceptibility to the studied human factors, and the appropriate degree to which they are affected. These values are arbitrary in our example, as no human operators will have a fixed response, but will hypothetically enable our learning model to track and account for these influences. Operator 1 is intended to be an experienced operator, with a faster than nominal CT. Performance is decreased by 20% however over the shift duration to account for fatigue. Operator 2 is intended to represent a consistent base or average case, with a nominal base CT, and no fatigue influence.

TABLE. 1 PARAMETERS OF THE HUMAN OPERATORS USED IN THE SIMULATION.

Operator Number	Base Cycle Time	Fatigue Modifier	Weekday Modifier	Shift Modifier
1	40	1.2	N	Y
2	45	1	Y	N
3	50	1.1	Y	Y

Operator 3 represents a new operator, who is slower in operation, with moderate fatigue response. Additionally, Operators 1 and 3 are deemed *Owls* and suffer from decreased morning performance.

The generated data is collated and used to form a dataset to train the neural network. Consideration of these data points will allow for the prediction of the performance of the HO by the RO, in advance, based on historical performance. Additionally, patterns in performance that are independent of the individual HO are more easily established, by aggregating the performance data for each operator into one singular dataset. A total of fifteen simulation runs were performed, and the data collated, for a total of approximately 7500 data instances. Each simulation run represented one day of operation, with three shifts, am midday, and pm. The operator assigned to each shift was varied to represent performance in the full range of working conditions; this was done every 5 shifts, representing a working week. Considering these variables in this way enables performance to be monitored, and patterns resolved over multiple timescales.

Neural Network Development

Neural Network development was done using the Java-based DeepLearning4j (DL4J) library to facilitate integration with AnyLogic and enable evaluation in a dynamic task environment. Initial development defined a simplistic, single-layer *perceptron* type network, to perform a multidimensional regression through the network, and provide a predicted numerical value for the CT of the human operator when provided with a new data instance. This value can then be used to inform the speed of movement, or the potential order of operations to better match the performance of the human counterpart, reducing the disparity and improving the fluency of the interaction.

As is typical of machine learning tasks, initial consideration must be given to the dataset. The dataset generated as detailed in the previous section consisted of four input features, the ON, SN, SD, and WD attributes, which were taken as inputs, and a label in the form of the corresponding cycle time. These input values are input to the network, passed through the hidden layers which encode the input/output mappings, to the output node, resulting in the value for the human cycle time. The structure of the network and the corresponding Java code is illustrated in Figure.2.

Standard techniques for data preprocessing to improve accuracy were considered, and the dataset was collected and divided into a training set and an isolated test set and shuffled.

Sigmoid activation functions were chosen, due to their wide use, and to enable the combined input of discrete and continuous data. To do this, each attribute was normalized according to its type, categorical values were encoded with a ‘one-hot’ normalization, (which treats each category as a set of binary input nodes, 3 values for the ON, and SN attributes, and 5 values for the WD, for 11 input nodes). The SD attribute, a continuous value, was normalized over a range of -1 to 1, to prevent saturation of the sigmoid activation functions. For the output layer, a RELU activation was chosen, to output a corresponding value that could be interpreted using the same normalization

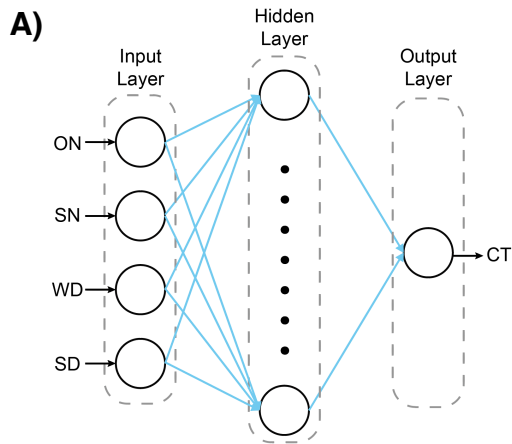

```

//Neural Network Configuration
MultiLayerConfiguration conf = new NeuralNetworkConfiguration.Builder()
    .seed(seed)
    .iterations(1)
    .optimizationAlgo(OptimizationAlgorithm.STOCHASTIC_GRADIENT_DESCENT)
    .learningRate(learningRate)
    .updater(Updater.NESTEROVS)
    .list()
    .layer(
        ind: 0, new DenseLayer.Builder()
            .nIn(numInputs)
            .nOut(numHiddenNodes)
            .weightInit(WeightInit.XAVIER)
            .activation(Activation.SIGMOID)
            .dropout(0.5)
            .build()
    )
    .layer(
        ind: 1, new OutputLayer.Builder()
            .nIn(numHiddenNodes)
            .nOut(numOutputs)
            .activation(Activation.IDENTITY)
            .lossFunction(LossFunctions.LossFunction.MSE)
            .build()
    )
    .pretrain(false).backprop(true).build();

```

FIGURE.2 A) DIAGRAM OF NETWORK STRUCTURE B) JAVA CODE IMPLEMENTING THE MULTI-LAYER NEURAL NETWORK.

weights as the training data into a prediction based on an input observation. Additionally, *dropout* was added to the hidden layer to help prevent overfitting.

The neural network was trained using a backpropagation approach to iteratively determine appropriate weights for each node. The use of backpropagation requires multiple passes through the dataset referred to as *epochs*, and the specification of a learning rate, to effectively train the network. Additionally, the number of nodes to include in the hidden layer remained to be determined. A learning rate of 0.01 was selected to mitigate vanishing gradients at the expense of training time; as the output range was relatively small. The Epoch and Number of Hidden Node parameters were evaluated using an exhaustive search approach. The DL4J library provides functionality for evaluation, for the hyperparameter optimization, each evaluation used the isolated test set, and the *Root-Mean-Squared-Error* (RMSE) was selected as the loss function. The results are presented in Figure.3.

Values for the parameters were selected based on the results of the parameter search. From the heatmap, it can be seen that some configurations are better performing than others and that most converge following approximately 50 training epochs, suggesting that further training is unnecessary and may lead to overfitting. A network containing 12 hidden nodes was selected over the 9-hidden-node configuration, as the learning rate of the

Epochs	Number of Hidden Nodes								
	8	9	10	11	12	13	14	15	16
10	23.96	21.81	16.41	18.90	13.97	7.95	12.22	6.53	6.17
20	9.37	10.19	7.27	12.63	10.27	6.49	6.47	11.02	12.49
30	6.32	6.53	6.14	9.77	7.35	7.68	6.44	18.07	8.80
40	6.17	6.16	6.37	9.06	6.83	7.82	6.35	18.68	9.00
50	6.19	6.19	6.58	6.83	6.57	7.96	6.31	7.02	8.92
60	6.19	6.22	6.71	6.84	6.29	8.04	6.30	6.82	8.79
70	6.87	6.21	6.77	6.86	6.30	8.07	6.30	6.74	8.70
80	6.86	6.19	6.79	6.84	6.30	8.07	6.29	7.81	6.57
90	6.87	6.18	6.78	6.82	6.32	8.07	6.27	7.77	6.18
100	6.90	6.18	6.78	6.80	6.34	8.07	6.26	7.79	7.92

FIGURE.3 HEATMAP OF RMSE SCORES, FROM RED (HIGHEST) TO BLUE (LOWEST)

12-node configuration is more stable; and despite the 9 node configurations moderately lower RMSE score.

This network configuration was then evaluated using a cross-fold validation, percentage split, and the previously isolated test dataset. Expectedly, evaluation on the isolated test set was the poorest, despite the test data being of similar form to the training data. The generated performance report for the isolated dataset test set case is shown in Figure.4.

```

o.d.o.l.ScoreIterationListener - Score at iteration 0 is 2093.0422916666666
o.d.o.l.ScoreIterationListener - Score at iteration 10 is 149.56703125
o.d.o.l.ScoreIterationListener - Score at iteration 20 is 101.54348958333333
o.d.o.l.ScoreIterationListener - Score at iteration 30 is 41.956243489583336
o.d.o.l.ScoreIterationListener - Score at iteration 40 is 6.974409993489584
o.d.o.l.ScoreIterationListener - Score at iteration 50 is 9.712725423177083
o.d.o.l.ScoreIterationListener - Score at iteration 60 is 5.61920166015625
o.d.o.l.ScoreIterationListener - Score at iteration 70 is 5.852053629557291
o.d.o.l.ScoreIterationListener - Score at iteration 80 is 5.616315511067708
Column MSE MAE RMSE RSE R^2
col_0 2.86414e+01 4.22350e+00 5.35177e+00 1.82026e+00 2.06842e-03

```

FIGURE.4: PERFORMANCE EVALUATION RESULTS OF THE INITIAL NETWORK ON ISOLATED TEST SET.

ON TASK EVALUATION

To more accurately assess the developed learning model, integration of the learning element into the simulation environment was necessary to evaluate the performance when faced with a representative task. Whilst the predictive analytical element is only a small contributor to the larger architecture that enables the emergence of intelligent behavior, its functionality with regards to providing reliable and accurate predictions of performance can be assessed.

These predictions must be supplied in real-time, with the intention that they may be used to dictate and inform the larger decision-making processes performed by the respective agent. In the simulated scenario, this action will be modulating the RO's speed parameter, to match its own cycle time to that of the current HO in the downstream position; in this way, the interstitial buffer zone will remain clear, and RO idle time and Workpiece In Progress (WIP) levels are reduced.

The Java classes which define the Neural Network behavior can be packaged using Maven to produce a Java Archive file

(.jar), which can be included in the AnyLogic model as a Dependency to allow access to both the defined classes, and the larger DL4j library. Function calls can then be made to the Neural Network to obtain a predicted value, passing information about the current simulation state to the Network through the function parameters. The simulation used to generate data was further developed by including the dl4j libraries as dependencies and including functionality to obtain a predicted value for the CT of the RO using the trained neural network. The function makes a call to the packed java class containing the network and receives the predicted value.

In the previous simulation case, the RO cycle time was fixed at 40 seconds. This can be seen to result in a varying period of time spent idle, due to the buffer being filled. The degree to which the variation in human performance influences this effect is illustrated in Figure.5, which plots the idle time and workpieces in progress, against time; for the total duration of the RO shift for both the static case, where the RO speed remains unchanged; and the dynamic case, where it is altered based on the predictions of the learning model. Shift changes occur for the HO's at 7200 seconds and 14400 seconds. The idle time can be seen to be influenced by the WIP level, as once this reaches 11, 10 products occupy the buffer zone, and the upstream RO must wait for an available buffer space to become clear before it can complete its operation.

To demonstrate the application of adaptable behavior, in this case, the RO makes an observation of the current environment, and these values are passed to the learning network. The network (trained offline on the corpus of simulated data) returns its prediction, and the CT of the robotic operator is adjusted to match this value. Figure.5 also illustrates the Idle Time and WIP levels when the learning functionality is enabled.

Whilst the WIP and RO idle time can be seen to decrease, the on-task evaluation of the neural network shows some interesting results. The performance of the network when evaluated using a test set suggested a suitably high correlation, and acceptable errors, however, this is potentially misleading when considering how such a model may perform on-task. When plotting the RO CT against the HO CT over the course of a shift, the network can be seen to identify the disparity in performance between operators, and to some degree, account for changes in behavior over shift duration (Figure.6).

What can be seen, is that in the dynamic case, adaptation of the robotic operator behavior leads to a reduction in the idle time of the robotic operator, and a decreased WIP level. The reduced idle time can be said to improve the *fluency* of this interaction, improving the collaborative abilities of the robotic element. The presented case is not exhaustive, and further validation work is needed to fully explore the application of such an approach, and the challenges that it presents.

Despite the relatively high evaluations scores, as the range of output behaviours (and hence the regression target for learning) is small, the output value will still score highly in the evaluation if it approximates the mean of the output cycle times. Whilst a level of adaptability and predictive accuracy can be seen with respect to the human factors influence, the influence of

these values on the underlying performance trends are subtle and may be obfuscated by the noise arising from the randomness of human performance. Further work on more advanced network architectures, to include concepts such as recurrency, may better be able to track the performance, taking into account sequential patterns as it learns, rather than trying to extrapolate them from the global dataset.

The results presented indicate that such differentiation enables customized policies of behaviour to be enacted based on the observed actions of the human counterpart and that such adaptability may have the potential to be usefully leveraged, through the reduction of robotic idle time, and levels of work in progress. This work presents a combined approach of these methodologies, and supports the authors hypothesis, that integration of intelligent manufacturing concepts may be used to alleviate the uncertainty caused by human components of these systems, and that the adaptable behavior that they enable can be seen to improve the fluency of the human-machine-interaction, and suggests that such an approach may be well suited to aiding collaborative task performance. The value of this work comes from the consideration of two schools of thought that currently exist with respect to improving the management and execution of manufacturing processes. Firstly, principles of intelligent manufacturing promote adaptability as a means to overcome uncertainty. Secondly, the study of human factors has developed a great deal of knowledge with regards to human behavior and the influence of numerous factors on task performance. Leveraging this knowledge can be used to inform adaptable behavior and enable collaborative behaviours to be enacted in response to human behaviours.

The presented solution is able to differentiate between multiple operators with limited development, although the sheer possibility of variation between human beings, and the number of inherited challenges from the many fields involved makes validation a difficult task. Certainly, the next stage of this work must be to begin evaluation using real-world data, complete with the challenges that this presents. In addition, a more detailed study is required to fully validate this method across a wider range of tasks and scenarios that may potentially be encountered.

As mentioned previously, the work presented is not exhaustive, and further work is planned to further investigate how to leverage the knowledge created using the learning approach. Multiple future predictions may be combined and used to influence behaviour, and multiple other factors may be combined into the decision-making process.

Much other work has been done within the field of cognitive computing and neuroscience, suggesting that other intelligent functions, including memory and perception, share the modular nature of analytical thinking. Further work could seek to reconcile the strengths of multiple types of network, such as convolutional nets for vision processing, or recurrent nets for more complex representations of memory, to facilitate additional intelligent functions and incorporate them into the control system.

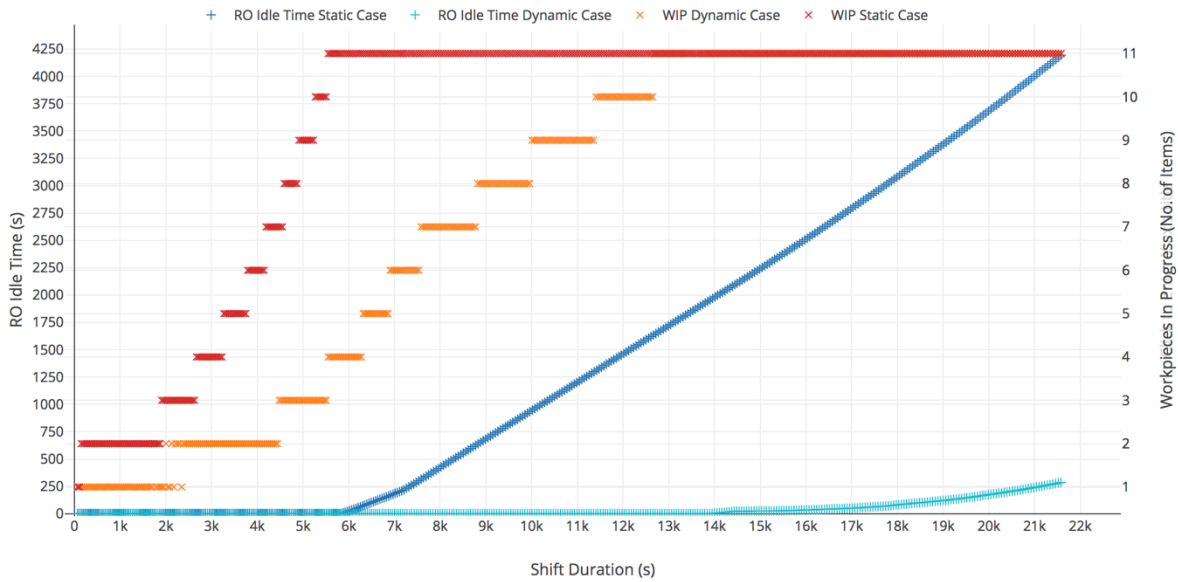

FIGURE.5: IDLE TIME AND WIP AGAINST SHIFT DURATION, FOR BOTH STATIC AND DYNAMIC BEHAVIOR CASES.

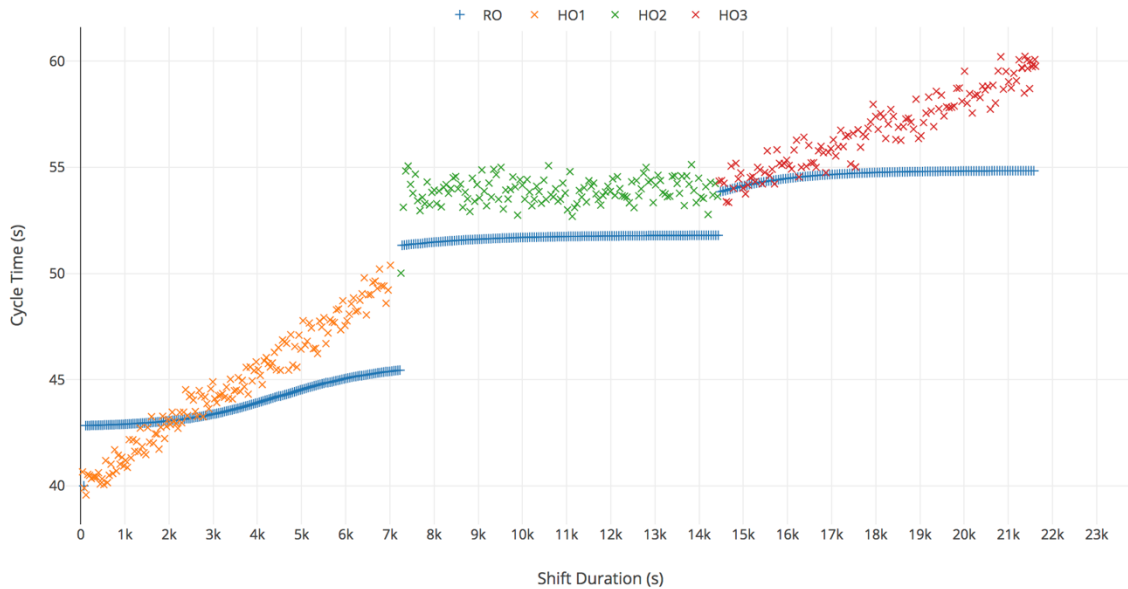

FIGURE.6: RO CT AND HO CT OVER TIME. RANDOM ELEMENT SEEDS ARE CHANGED BETWEEN RUNS, ENSURING APPROPRIATE VARIABILITY WHEN THE SAME CONDITIONS ARE IMPOSED.

CONCLUSIONS

The aim of the presented research was to further understanding of how to better enable collaborative, intelligent behavior in human-robot-interaction within the manufacturing context. A crucial element of this is the ability to understand how associated human factors may lead to unstable and varied performance in human colleagues. The presented, solution, whilst not fully representative, demonstrates that a simplistic model is able to make appropriate predictions to inform decision making, and the exhibition of adaptable, and autonomous behavior for working

with different operators; and to do so in a real-time setting. The work highlights the benefits in terms of collaborative behaviour that the application of intelligence within manufacturing facilitates.

This work combines elements of many fields, and as such, inherits a number of unresolved issues. Establishing optimal behaviours will most likely require appropriate consideration of additional agents in the system, and a measure of combined influence, both of the action of others on the intelligent agent, but also the intelligent agents own actions on others.

Despite the capacity to reduce the time spent idle and the level of work in progress, the network is still susceptible to inaccuracy and is less capable of fully establishing the influence of human factors. Additional consideration must be given to factors associated with processing real-world data, noise, missing values, and additional randomness associated with Human-Beings as yet unaccounted for. This work represents a portion of a larger and ongoing project on the application of learning to facilitate intelligent behavior, and extensive further research is planned to investigate these areas further.

NOMENCLATURE

CT = Cycle Time
 HO = Human Operator
 RO = Robot Operator
 ON = Operator Number
 SN = Shift Number
 SD = Shift Duration
 WD = Weekday
 WIP = Workpieces In Progress

REFERENCES

- [1] Moniz, A. B., and Krings, B.-J., 2016, "Robots Working with Humans or Humans Working with Robots? Searching for Social Dimensions in New Human-Robot Interaction in Industry," *Societies*, 6(3), p. 23.
- [2] Lee, E. A., "Cyber physical systems: Design challenges," *Proc. 2008 11th IEEE International Symposium on Object and Component-Oriented Real-Time Distributed Computing (ISORC)*, IEEE, pp. 363-369.
- [3] Schuh, G., Potente, T., Wesch-Potente, C., Weber, A. R., and Prote, J.-P., 2014, "Collaboration Mechanisms to increase Productivity in the Context of Industrie 4.0," *Procedia CIRP*, 19, pp. 51-56.
- [4] Gurgun, L., Gunalp, O., Benazzouz, Y., and Gallissot, M., "Self-aware cyber-physical systems and applications in smart buildings and cities," *Proc. Proceedings of the Conference on Design, Automation and Test in Europe, EDA Consortium*, pp. 1149-1154.
- [5] Permin, E., Bertelsmeier, F., Blum, M., Bützler, J., Haag, S., Kuz, S., Özdemir, D., Stemmler, S., Thombansen, U., and Schmitt, R., 2016, "Self-optimizing production systems," *Procedia CIRP*, 41, pp. 417-422.
- [6] Leitão, P., Barbosa, J., Papadopoulou, M.-E. C., and Venieris, I. S., "Standardization in cyber-physical systems: The ARUM case," *Proc. Industrial Technology (ICIT)*, 2015 IEEE International Conference on, IEEE, pp. 2988-2993.
- [7] Cao, Y., Yu, W., Ren, W., and Chen, G., 2013, "An overview of recent progress in the study of distributed multi-agent coordination," *IEEE Transactions on Industrial Informatics*, 9(1), pp. 427-438.
- [8] Leitão, P., and Restivo, F., 2006, "ADACOR: A holonic architecture for agile and adaptive manufacturing control," *Computers in industry*, 57(2), pp. 121-130.
- [9] Van Brussel, H., Wyns, J., Valckenaers, P., Bongaerts, L., and Peeters, P., 1998, "Reference architecture for holonic manufacturing systems: PROSA," *Computers in industry*, 37(3), pp. 255-274.
- [10] Leitão, P., and Colombo, A. W., "Petri net based methodology for the development of collaborative production systems," *Proc. Emerging Technologies and Factory Automation, 2006. ETFA'06. IEEE Conference on*, IEEE, pp. 819-826.
- [11] Young, J. E., Sung, J., Voids, A., Sharlin, E., Igarashi, T., Christensen, H. I., and Grinter, R. E., 2011, "Evaluating human-robot interaction," *International Journal of Social Robotics*, 3(1), pp. 53-67.
- [12] Bütepage, J., and Kragic, D., 2017, "Human-Robot Collaboration: From Psychology to Social Robotics," *arXiv preprint arXiv:1705.10146*.
- [13] Djuric, A. M., Urbanic, R., and Rickli, J., 2016, "A Framework for Collaborative Robot (CoBot) Integration in Advanced Manufacturing Systems," *SAE International Journal of Materials and Manufacturing*, 9(2016-01-0337), pp. 457-464.
- [14] Eckardt, M., Buchheim, A., and Gerngross, T., 2016, "Investigation of an automated dry fiber preforming process for an aircraft fuselage demonstrator using collaborating robots," *CEAS Aeronautical Journal*, 7(3), pp. 429-440.
- [15] Agravante, D. J., Cherubini, A., Bussy, A., Gergondet, P., and Kheddar, A., "Collaborative human-humanoid carrying using vision and haptic sensing," *Proc. Robotics and Automation (ICRA)*, 2014 IEEE International Conference on, IEEE, pp. 607-612.
- [16] Rozo, L., Calinon, S., Caldwell, D. G., Jimenez, P., and Torras, C., 2016, "Learning physical collaborative robot behaviors from human demonstrations," *IEEE Transactions on Robotics*, 32(3), pp. 513-527.
- [17] Wang, Y., and Zhang, F., 2017, "Trends in Control and Decision-Making for Human-Robot Collaboration Systems," *Springer*.
- [18] Mohammed, A., Schmidt, B., and Wang, L., 2016, "Active collision avoidance for human-robot collaboration driven by vision sensors," *International Journal of Computer Integrated Manufacturing*, pp. 1-11.
- [19] Monostori, L., 2014, "Cyber-physical production systems: Roots, expectations and R&D challenges," *Procedia CIRP*, 17, pp. 9-13.
- [20] Firoiu, V., Whitney, W. F., and Tenenbaum, J. B., 2017, "Beating the World's Best at Super Smash Bros. with Deep Reinforcement Learning," *arXiv preprint arXiv:1702.06230*.
- [21] Lowe, R., Wu, Y., Tamar, A., Harb, J., Abbeel, P., and Mordatch, I., 2017, "Multi-Agent Actor-Critic for Mixed Cooperative-Competitive Environments," *arXiv preprint arXiv:1706.02275*.
- [22] Laird, J. E., Lebiere, C., and Rosenbloom, P. S., 2017, "A Standard Model of the Mind: Toward a Common Computational

Framework Across Artificial Intelligence, Cognitive Science, Neuroscience, and Robotics," *AI Magazine*, 38(4).

[23] Witten, I. H., Frank, E., Hall, M. A., and Pal, C. J., 2016, *Data Mining: Practical machine learning tools and techniques*, Morgan Kaufmann.

[24] Goodfellow, I., Bengio, Y., and Courville, A., 2016, *Deep learning*, MIT Press.

[25] Schmidhuber, J., 2015, "Deep learning in neural networks: An overview," *Neural networks*, 61, pp. 85-117.

[26] Noor, A. K., 2015, "Potential of cognitive computing and cognitive systems," *Open Engineering*, 5(1), pp. 75-88.

[27] Modha, D. S., Ananthanarayanan, R., Esser, S. K., Ndirango, A., Sherbondy, A. J., and Singh, R., 2011, "Cognitive computing," *Communications of the ACM*, 54(8), pp. 62-71.

[28] Vernon, D., 2014, *Artificial cognitive systems: A primer*, MIT Press.

[29] Wiltshire, T. J., Barber, D., and Fiore, S. M., "Towards modeling social-cognitive mechanisms in robots to facilitate human-robot teaming," *Proc. Proceedings of the Human Factors and Ergonomics Society Annual Meeting*, SAGE Publications Sage CA: Los Angeles, CA, pp. 1278-1282.

[30] Salvucci, D., Boer, E., and Liu, A., 2001, "Toward an integrated model of driver behavior in cognitive architecture," *Transportation Research Record: Journal of the Transportation Research Board*(1779), pp. 9-16.

[31] Anderson, J. R., 1996, "ACT: A simple theory of complex cognition," *American Psychologist*, 51(4), p. 355.

[32] Laird, J. E., Newell, A., and Rosenbloom, P. S., 1987, "Soar: An architecture for general intelligence," *Artificial intelligence*, 33(1), pp. 1-64.

[33] Isla, D., Burke, R., Downie, M., and Blumberg, B., "A layered brain architecture for synthetic creatures," *Proc. International Joint Conference on Artificial Intelligence*, LAWRENCE ERLBAUM ASSOCIATES LTD, pp. 1051-1058.

[34] Hart, S. G., and Staveland, L. E., 1988, "Development of NASA-TLX (Task Load Index): Results of empirical and theoretical research," *Advances in psychology*, Elsevier, pp. 139-183.

[35] Hancock, P., Williams, G., and Manning, C., 1995, "Influence of task demand characteristics on workload and performance," *The International Journal of Aviation Psychology*, 5(1), pp. 63-86.

[36] Lorist, M. M., Klein, M., Nieuwenhuis, S., De Jong, R., Mulder, G., and Meijman, T. F., 2000, "Mental fatigue and task control: planning and preparation," *Psychophysiology*, 37(5), pp. 614-625.

[37] Lorist, M. M., Kernell, D., Meijman, T. F., and Zijdwind, I., 2002, "Motor fatigue and cognitive task performance in humans," *The Journal of physiology*, 545(1), pp. 313-319.

[38] Benedetti, A. A., Diefendorff, J. M., Gabriel, A. S., and Chandler, M. M., 2015, "The effects of intrinsic and extrinsic sources of motivation on well-being depend on time of day: The moderating effects of workday accumulation," *Journal of Vocational Behavior*, 88, pp. 38-46.

[39] Enoka, R. M., and Duchateau, J., 2016, "Translating fatigue to human performance," *Medicine and science in sports and exercise*, 48(11), p. 2228.

[40] Koslowsky, M., and Babkoff, H., 1992, "Meta-analysis of the relationship between total sleep deprivation and performance," *Chronobiology International*, 9(2), pp. 132-136.

[41] Dinges, D. F., Pack, F., Williams, K., Gillen, K. A., Powell, J. W., Ott, G. E., Aptowicz, C., and Pack, A. I., 1997, "Cumulative sleepiness, mood disturbance, and psychomotor vigilance performance decrements during a week of sleep restricted to 4-5 hours per night," *Sleep*, 20(4), pp. 267-277.

[42] Blake, M., 1967, "Time of day effects on performance in a range of tasks," *Psychonomic science*, 9(6), pp. 349-350.

[43] Kerkhof, G. A., 1985, "Inter-individual differences in the human circadian system: a review," *Biological psychology*, 20(2), pp. 83-112.

[44] Testu, F., and Clarisse, R., 1999, "Time-of-day and day-of-week effects on mnemonic performance," *Chronobiology international*, 16(4), pp. 491-503.

[45] Dode, P., Greig, M., Zolfaghari, S., and Neumann, W. P., 2016, "Integrating human factors into discrete event simulation: a proactive approach to simultaneously design for system performance and employees' well being," *International Journal of Production Research*, 54(10), pp. 3105-3117.

[46] Bell, P. A., 2016, "Effects of Noise and Heat Stress on Primary and Subsidiary Task Performance," <http://dx.doi.org/10.1177/001872087802000614>.

[47] Driskell, J. E., and Salas, E., 2013, *Stress and human performance*, Psychology Press.

[48] Berthoud, H.-R., 2007, "Interactions between the 'cognitive' and 'metabolic' brain in the control of food intake," *Physiology & behavior*, 91(5), pp. 486-498.

[49] Smith, A. P., and Miles, C., 1987, "The combined effects of occupational health hazards: an experimental investigation of the effects of noise, nightwork and meals," *International Archives of Occupational and Environmental Health*, 59(1), pp. 83-89.

[50] Unhelkar, V. V., Siu, H. C., and Shah, J. A., "Comparative performance of human and mobile robotic assistants in collaborative fetch-and-deliver tasks," *Proc. Proceedings of the 2014 ACM/IEEE international conference on Human-robot interaction*, ACM, pp. 82-89.