

**Genetic Testing for Sudden  
Arrhythmic Death Syndrome and  
the Coroners' System of England  
and Wales**

**Christopher Goldsworthy**

**School of Social Sciences**

**Cardiff University**

**Doctor of Philosophy**

**2016**



## Acknowledgements

First and foremost, a debt of gratitude is owed to Anne and John Jolly, and SADS UK, not only for providing financial support, making this research possible, but also for remaining a constant source of inspiration throughout this research process.

I would also like to thank Adam Hedgecoe and Nicky Priaux, who provided mentorship over and above that expected of PhD supervisors. The balance achieved between guidance, encouragement and academic freedom has enabled me to develop my own academic identity which reaches far beyond the limits of this thesis. I would also like to thank Dhavendra Kumar for providing access to a social world that would otherwise be inaccessible, as well as maintaining enthusiasm for sociological questions, in a way rarely seen in clinical genetics. The influence of academic colleagues and friends from across the world cannot be underestimated. Particular gratitude is owed to Ine van Hoyweghen, who not only made me feel welcome when visiting KU Leuven, but also encouraged me to think beyond the standard disciplinary narratives that pervade science and technology studies and the sociology of health and illness.

This research was made possible with financial support from the Economic and Social Research Council, with support from SADS UK.

To the numerous anonymous professionals that manage SADS on a day-to-day basis, I would like to thank you not only for allowing me to access your social worlds, but also for tolerating my, sometimes esoteric, lines of questioning. I would also like to thank these numerous individuals for their continued interest in this project and the problem of SADS which connects every account given.

To my wife, Naomi, I owe perhaps the greatest thanks. She has provided unwavering support, having to endure drafts of work and conversations on topics which can be

perceived as less than palatable. More than this, she has been a constant source of encouragement and inspiration, without which I would not be here today.

Any mistakes and problems remaining in this work are mine and mine alone.

## Abstract

The author of this thesis examines how SADS is made and remade within interdisciplinary professional practice. Whilst recent sociological scholarship has followed the discourse of '*molecularization*' when examining the construction of biomedical categories, I instead place the genetic as part of a broader clinical and medico-legal system. Whilst it is accepted that there are genetic aspects of SADS this does not reduce the usefulness of other disciplinary explanations in practice.

This thesis is situated around the molecular autopsy, a technology simultaneously employed to identify the cause of death and help in the diagnosis and treatment of family members of the deceased. As such, this thesis examines the professional system which surrounds this technology across the medico-legal – clinical divide. In doing so, the author of this thesis argues that the usefulness of genetic testing for SADS is an explicitly political problem. Suggesting that the current focus of research examining translational medicine falls short by focusing on the translation from 'Bench to Bedside', instead arguing for the importance of examining the political, and socio-economic space in which the technology is to reside.

Finally, I explore the co-construction of the professional system of making SADS. A relational approach to professionalism is developed as a way to examine how mutuality is achieved during collaboration between distinct epistemic cultures. The consequence of such an approach is the ability to understand how professional groups are able to mobilise multiple conceptions of SADS in the pursuit of preventing future deaths. Making SADS gains further meaning in that I argue that understandings of SADS are distinct to accounts given in practice. Understandings of the usefulness of genetic testing for coroners is thus, not only based upon the ability of genetics to serve a

particular function, but is based upon a fragmented account of the technology,  
rhetorically produced by clinicians.

# Contents

<b>Declaration .....</b>	<b>i</b>
<b>Acknowledgements.....</b>	<b>ii</b>
<b>Abstract.....</b>	<b>iv</b>
<b>Contents .....</b>	<b>vi</b>
<b>Preface.....</b>	<b>1</b>
<b>1. Introduction.....</b>	<b>4</b>
1.1 A Matter of Death and Life.....	9
1.2 Sociology of the Professional Management of Death .....	14
1.3 Genetic (Un)Exceptionalism: Critiquing a Disciplined Understanding of SADS....	20
<b>Chapter 2 – Theoretical Considerations.....</b>	<b>23</b>
2.1 A Relational Understanding of Professionalism.....	23
2.2 Performativity in Professional Practice .....	26
<b>Chapter 3 – Methodology .....</b>	<b>32</b>
3.1 Pre-Fieldwork – Getting to Know the Field(s) .....	33
3.2 Spaces of Practice and Co-Construction .....	38
3.3 Research Design.....	42
3.4 Analysis and Data Organisation .....	50
<b>Part I: Genetic Testing for Inherited Cardiac Conditions in the NHS .....</b>	<b>54</b>
<b>Chapter 4: Political Translation of Genetic Testing for Inherited Cardiac Conditions .....</b>	<b>54</b>
4. 1 Free Samples.....	57
4.2 Engineering through Robots.....	62

4.3 Genetics <i>Lite</i> .....	68
<b>Chapter 5: Ruling in, Ruling Out, Risk and Rationing</b> .....	<b>75</b>
5.1 Ruling in: 'Barn Doors' and 'Good Goers' .....	76
5.2 Ruling out .....	81
<b>Chapter 6: Experimental Misconception: Mutuality of Research and the Clinic in Clinical Genetics</b> .....	<b>90</b>
6.1 Clinical Research in Cardiac Genetics .....	93
6.2 Clinician-Scientist .....	96
6.3 Research Supplementing the Clinic .....	101
6.4 Mutually Beneficial Relationships.....	105
6.5 Supplementary Misconception.....	107
<b>Chapter 7: Next Generation Sequencing in Clinical Practice: The Translation and Interpretation of Genomic Data in the Diagnostic Lab and the Clinic</b> .....	<b>116</b>
7.1 Big Genomic Data in the NHS .....	118
7.2 Contextualisation, Transformation and Manipulation of Genomic Data .....	129
<b>Part II: Medico-Legal Aspects of SADS</b> .....	<b>143</b>
<b>Chapter 8: The Medico-Legal Usefulness of Genetics</b> .....	<b>143</b>
8.1 The Place of Medical Evidence in Coronial Practice .....	145
8.2 The Burden of the Burden of Proof.....	151
8.3 The Political Construction of SADS as a Cause of Death.....	154
8.4 'Do you want <i>A</i> cause of death or <i>The</i> cause of death?' .....	161
8.5 Making a Case for SADS .....	166
8.6 The Place of Genetics in Coronial Practice.....	170
<b>Chapter 9: Co-construction of the Medico-Legal Molecular Autopsy</b> .....	<b>184</b>
9.1 Usefulness of the Molecular Autopsy in the Clinic .....	187
9.2 Issues over Tissue.....	193



<b>Chapter 10: The ‘Magnitude’ of Deaths Categorised as SADS .....</b>	<b>207</b>
<b>Part III: Making SADS .....</b>	<b>211</b>
<b>Chapter 11: What Is It? .....</b>	<b>214</b>
11.1 Different and Differential Standards of Diagnoses .....	217
11.2 Who Is It? .....	219
11.3 ‘ <i>Forme Fruste</i> ’ .....	227
11.4 The Usefulness of SADS.....	236
<b>Chapter 12: From Sudden Death to Cardiac Screening .....</b>	<b>246</b>
12.1 Politics of Interprofessional Separation and Practical Collaboration.....	250
12.2 Social Distance and Professional Organisation .....	255
12.3 Fragmented Accounts .....	264
12.4 Mind the Gap.....	275
12.5 Translators and Brokers.....	282
<b>Conclusion: Making SADS Genetic .....</b>	<b>295</b>
Practical Implications: The Interdisciplinary Usefulness of the Molecular Autopsy	301
<b>References.....</b>	<b>303</b>
<b>Appendices.....</b>	<b>331</b>
Appendix 1: ONS response to Jim Shannon MP.....	331
Appendix 2: The AICC Pathway for the Management of SADS.....	333
Appendix 3: Research Participant Information Sheet.....	334
Appendix 4: Consent Form .....	336

## Figures:

Figure 1:	Family Tree (Hollman et al, 1960 p. 449)	10
Figure 2:	Interview Demographics	39
Figure 3:	Research Site Demographics	39
Figure 4:	WHSSC: 2014. Patient Referral Pathway	72
Figure 5:	Number of Deaths per Year Associated with SADS	208

## Abbreviations

AICC:	The Association for Inherited Cardiac Conditions
ARVC:	Arrhythmogenic Right Ventricular Cardiomyopathy
AWMGS:	All Wales Medical Genetics Service
ECG:	Electrocardiogram
FFPET:	Formalin Fixed Paraffin Embedded Tissue
GIS:	Genetics Information Service
GWAS:	Genome Wide Association Study
HCM:	Hypertrophic Cardiomyopathy/ 'Hocum'
HTA:	Human Tissue Act
ICC:	Inherited Cardiac Condition
ICD:	Implantable Cardioverter Defibrillator
LQTS:	Long QT Syndrome
MDT:	Multi-Disciplinary Team
SADS:	Sudden Arrhythmic Death Syndrome/Sudden Adult Death Syndrome
SIDS:	Sudden Infant Death Syndrome
WES:	Whole Exome Sequencing
WGS:	Whole Genome Sequencing
WHSSC:	Welsh Health Specialist Services Committee



## Preface

On January 10<sup>th</sup> 1998 at around 6AM, Lisa Jane Browne aged 27 suffered a sudden cardiac arrest, probably as her alarm rang to awaken her for work. As this was a sudden and unexpected death, the case was referred to the local coroner's office in Cheshire. The coroner ordered a post-mortem examination by pathologists at the local hospital. This revealed no pathological cause for her death and the subsequent coroner's inquest held on January 26<sup>th</sup> 1998 came to an open verdict with the cause of death registered as unascertainable.

Lisa had been to her GP prior to her death, who diagnosed stress from her symptoms of light-headedness and palpitations, however this did not figure in the investigation by the coroner.

In September 1998, Lisa's mother and father both went for cardiac screening at St. Georges following information passed to them by a friend. Her father was found to have the phenotype for Long QT syndrome (LQTS), an inherited condition of the conduction system with the serious potential symptom of sudden death. Following this Lisa's sister received screening and was also diagnosed with LQTS.

By December 2001, Dr. Elijah Behr of St. Georges Hospital, who had initially screened the family, was able, through the use of genetic testing, to identify a mutation for Long QT syndrome type 2 (HERG)(Cardiac Risk in the Young, 2015b) in Lisa's father and sister. LQTS 2 is a genetic subtype associated with cardiac events triggered by being suddenly woken or startled.

During Lisa's post-mortem, the pathologists stored samples of myocardium, which remained stored at the hospital where the post-mortem was carried out. This tissue was

made available to Dr. Behr who was able to, through the use of the molecular autopsy, conduct a genetic analysis, looking for the specific mutation found in her family members, on a research basis. By March 2005, he found that Lisa did indeed possess the abnormal HERG gene associated with LQTS.

During the intervening time, the coroner who originally presided over Lisa's death had retired and H.M. Mr. Nicholas Rheinberg was appointed in his place. Lisa's parents approached Mr. Rheinberg with the new evidence from the molecular autopsy showing that Lisa had a genetic mutation associated with LQTS. As a result of this, and at great risk to the professional reputation of the Cheshire coroner's service, Mr. Rheinberg supported Lisa's parents through the process of judicially reviewing the conclusion by his predecessor.

Finally after 8 years, on April 26, 2006, the conclusion of Lisa's inquest was overturned, replacing the 'open' verdict and the cause of death as unascertainable, based on new evidence, with the conclusion: Natural Causes;

Cause of death:

- 1a. Acute left ventricular failure caused by;
- 1b. Long QT Syndrome (due to sub-type LQT2 mutation) (Cardiac Risk in the Young, 2015a).

During the process of establishing how Lisa died, not only were her father and sister diagnosed with LQTS, but her sisters 2 children also presented with QT prolongation when assessed at an inherited cardiac conditions (ICC) clinic. Lisa's sister now has an Internal Cardioverter Defibrillator (ICD) and is treated with beta-blockers and her two sons' QT intervals are being managed with beta-blockers (Cardiac Risk in the Young, 2015a).

This was the first molecular autopsy conducted in Britain.

The impact of the molecular autopsy in this case cannot be underestimated, both in terms of the closure of knowing what caused their daughters/sisters/aunts sudden death, as well as in terms of the reduced risk of a similar fate befalling other 'affected' family members. However, the molecular autopsy remains an underused resource both in the medical and medico-legal setting. Moreover, the sharing of information between the medico-legal domain of the coroner and medical domain of the cardiology or genetics clinic for purposes of preventing future similar deaths in family members remains a highly underdeveloped area.

In this rare case, both the coroner and the cardiologist went beyond their formal jurisdiction to aid Lisa's family in getting answers, with the coroner aiding the cardiologist in accessing the stored myocardium as well as supporting the judicial review of his own service, and the cardiologist utilising research resources to access a technology not available through the NHS. Thus, the formal mechanisms of using the molecular autopsy had not, nor have they yet been, agreed upon across the medico-legal – clinical boundary.

## **1. Introduction**

The impetus for developing this study stemmed from a concern by those in the cardiac genetics community that coroners were not engaging with the molecular autopsy technology which, if used efficiently, could aid in the prevention deaths in families already bereaved due to SADS. This came to my attention initially from a practicing clinical geneticist who voiced his concern that there was a disconnect between the medico-legal system of the coroner and the clinical system within which he worked. He gave the example of the British Heart Foundation Genetic Information Service (GIS), a service set up as an information line for families and professionals who have been confronted with a sudden death thought to be associated with an inherited cardiac condition (ICC). This clinical geneticist signed up as a contact point for this service, as did his colleagues in the local cardiology department, as such he expected to receive phone calls from recently bereaved families, coroners and pathologists inquiring about how to manage the genetic aspects of these conditions. However since the GIS began in 2009 he has received no contact from any coroner or pathologist investigating a death suspected to be associated with an ICC. The assumption was that coroners were disinterested or unaware of the familial consequences of SADS related deaths. Exploring the deeper reasoning behind this formed the basis of the present doctoral project.

When making preliminary contact with coroners at the beginning of this project it soon became apparent that contrary to the assumptions of the clinical geneticist, coroners were acutely aware of the inherited nature of ICC's. As such, practical provisions had been made to ensure families were made aware of the potential familial consequences of SADS or an identified ICC in an attempt to advise families to seek specialist medical advice. However,

structural, legal and economic constraints limit the extent to which a coroner can support the clinical screening of families. These constraints have a far greater impact on the coroner's ability to engage with the molecular autopsy during the investigation of a sudden death, when compared with the assumed lack of interest presented by the geneticist earlier.

It became clear that there was a disconnect in the way in which professionals from the clinical world understand and experience, what they see as ICC's compared to the way those from the medico-legal world see SADS. Thus, a primary aim of this study is to examine the way these distinct epistemic cultures<sup>1</sup> (Knorr-Cetina, 1999) mobilise their understandings of SADS within professional practice and how this is shaped by the messy space in which these distinct professional groups work. A space in which political, economic and disciplinary factors impact upon the ways in which these groups can engage with SADS and the genetic technologies available for testing for the associated cardiac conditions in both the living and the dead.

Whilst previous studies have reported on the impact of political and socio-economic factors at the clinical coal-face, upon the understanding, experience and subsequent uptake of genetic technologies (Hedgecoe, 2004), these ideas have yet to expand beyond the boundaries of the clinic into other professional realms in which genetic testing and information may be pertinent. Thus drawing theoretical insight from Pinch and Bijkers (1984) *Social Construction of Technology*, a primary function of this study is to unpick how the political and socio-economic distinctions between the clinical and medico-legal world impact upon their perceptions of SADS and the genetic testing associated with it in its various forms. This will be represented in the first two parts of this thesis, as this study focuses at the practice level, I will examine accounts of how political and socio-economic

---

<sup>1</sup> Knorr-Cetina's (1999) *epistemic cultures* is used in this study as to avoid the permanency which is assumed in other similar concepts such as *Social Worlds* (Clarke and Star, 2008) or *Forms of Life* (Wittgenstein, 1953). The epistemic element of this concept assumes flexibility as well as the potential for inter-cultural development.



factors such as political changes and resource rationing affect the day to day practices of professionals within the clinical and medico-legal setting. Part 1 will focus upon the medical setting in which genetic testing for ICC's was implemented soon after the completion of the Human Genome Project and the large UK Department of Health investment into the effective translation of genetic technologies into clinical practice during the Genetics Knowledge Parks initiative. This part will also flesh out how the translation of genetic testing for ICC's was achieved at the local clinical level, discussing how this inherently complex process, defined not by innovation but by compromise, has impacted upon the very structure of ICC services in locations across England and Wales. Finally, this part will discuss how useful genetic information is within this setting, offering a critique of well versed discourses in the science and technology studies that the molecular or genetic increasingly represents the regime of truth in biomedical science (Rose, 2001).

Part 2 will consider the organisation of the medico-legal setting in relation to the investigation of sudden death thought to be SADS related. I will discuss how the legal space in which the coroner and pathologist practice in this setting impacts upon the way these professionals are able to engage with SADS and any additional diagnostic technologies, such as the molecular autopsy. This section will also highlight how the work of the coroner can have implications for the clinical setting and the medical understanding of SADS. I position the coroner as a gatekeeper of knowledge and information pertaining to certain categories of death at both the macro and micro level. In keeping with Prior (1989) the coroner is positioned as the profession with the authority to construct categories of death as well as deciding which deaths are placed in such categories, thus the way clinicians know about the magnitude of SADS (Papardakis et al 2009) is mediated by the way coroners register these deaths. At the micro level coroners have the authority to decide the extent of the investigation into SADS related deaths as well as maintaining authority over who can and cannot access information pertaining to particular deaths, as

such the coroner controls who can access specific information as well as actively constructing information within the disciplined context of the coroner's law.

With this in mind, it becomes necessary to ask not only how these two distinct epistemic cultures differ in relation to their understanding and experience of SADS and genetic testing, but how these differences effect collaborative practice in relation to the professional system from the sudden unexpected death to the screening, diagnosis and treatment of surviving family members. This will be the focus of the third and final part of the thesis. In keeping with Mol (2002), this part will maintain that the political and socio-economic environment in which professionals experience SADS and genetic testing has a dramatic impact upon the way each group understands the phenomena and the technology, this results in multiple, potentially incompatible constructions and perceptions. I have been conscious thus far to not give a definition of SADS, this is partly due to the multiple conceptions of SADS by professional groups, but also due to the overwhelming consensus that 'We don't have anything called SADS' (Cardiologist, 6). Instead there is a sense in which the term SADS is used to span the boundary across the medico-legal – clinical divide, to ensure as much as possible, that the appropriate information shared with clinicians to support the effective management of families. Thus this section will examine how SADS is multiply conceived and constructed not only based upon professional experience and disciplinary constraints but also as a rhetorical tool to support the success of the interdisciplinary endeavour to reduce the possibility for future deaths in the same family.

The final chapter in this part will examine the interdisciplinary professional organisation of the system from sudden death to the diagnosis and treatment of family members.

Focussing specifically upon how each group overcomes the limitations of their own jurisdiction by drawing upon the skills, expertise and resources of others, this chapter will

discuss the methods by which professional groups negotiate disciplinary differences to ensure effective collaboration in practice.

The narrative provided throughout this thesis will be grounded in considerations of how useful the molecular autopsy is in the professional system configured around the identification diagnosis and treatment of SADS.

## **1.1 A Matter of Death and Life**

The development of our understanding of ICC's has historically been an interdisciplinary endeavour, in which the medico-legal investigation has maintained an integral function. The first recognition of the hereditary nature of one of these conditions came from London pathologist Donald Teare (1958). The importance of this finding was undersold by Teare and reference to the inheritance of what we now know as hypertrophic cardiomyopathy is only mentioned in a footnote to his now famous paper:

'On December 13, 1956, K. C., aged 16, a brother of Case No. 5, collapsed and died while riding his bicycle. No previous medical history was available. Post mortem he was found to be a well nourished and well developed young boy whose heart was virtually identical in appearance with that of his sister, showing a localized hypertrophy affecting the anterior wall and interventricular septum. By coincidence on the day of his death his younger sister attended the outpatient department of Hammersmith hospital and was found to have signs identical with her brother.'

(Teare, 1958 p. 7)

The novelty of the paper for Teare was in the discovery of a new pathological entity, defined by asymmetrical hypertrophy of the left ventricle. The importance of this should not be played down; it offered a diagnostic criteria for a new condition which soon proliferated across the world (Watkins and Sen-Chowdhry, 2008). However this paper, as well as a publication one year later (Hollman et al, 1960) gained further traction in the

genetics community through the authors meticulous construction of the first family pedigree with 'asymmetrical hypertrophy':

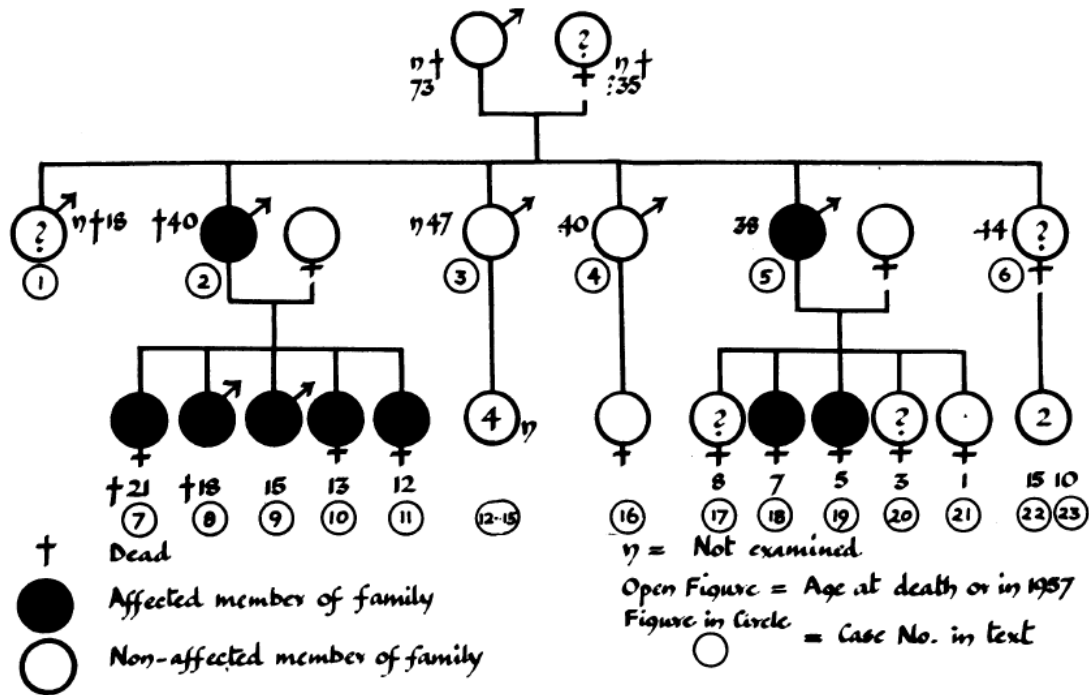

FIG. 1.—Family tree.  
449

2 H

Figure 1. Family Tree (Hollman et al, 1960 p. 449)

As a result of the foundations laid by Teare, many clinical advancements were made such as surgical treatments for cardiomyopathy related complications (Watkins and Sen-Chowdhry, 2008), however Teares' work had the greatest impact for studies in genetics and the study of familial cases of hypertrophic cardiomyopathy. Lawrence Brent and his colleagues at Pittsburgh were able to show that the inheritance pattern for this condition was autosomal dominant (Brent et al, 1960) and Pare and colleagues in Montreal conducted the largest family study of cardiomyopathy patients consisting of 77 individuals and 4 generations (Pare et al, 1961).

28 years later, in 1989, the group who studied the French-Canadian family were able to pin point the genetic cause of the condition in this family (Jarcho et al, 1989) located on

chromosome 14q1. The genetic findings and the methodology from this study were later applied to the next generation of the original Teare (1958) study family, in which the same gene mutation was found.

In 2005, the Department of Health published Chapter 8 of the Coronary Heart Disease National Service Framework on Arrhythmias and Sudden Death (Department of Health, 2005). This document positioned the diagnosis and treatment of inherited cardiac diseases (ICC) high on the public agenda. When asked how his ICC clinic was developed, an esteemed cardiologist in the field attributed it directly to the publication of this document:

‘Chapter 8 of the NSF was published in 2005 and that very clearly gives a demand for a sudden death clinic.’

(Cardiologist 1)

This was not an isolated event as ICC clinics became more prominent across England and Wales and by 2015, there were 22 NHS funded ICC services consisting of multi-disciplinary clinics dedicated to the diagnosis and treatment of ICC's such as cardiomyopathies and channelopathies.

These services had at their core the ethic to prevent sudden deaths in previously bereaved families, this is embedded within Chapter 8, which explicitly advocates the targeted use of genetic testing as a means of risk stratifying family members:

‘Effective evaluation of relatives [of those who have died of suspected SADS condition], guided by genetic testing can prevent further deaths in the family.’

(p. 11)

This can be read as a process of ‘molecularization’ (Rose, 2001, p. 13), in which the gaze of practitioners is reorganised at to focus on the molecular level, as Rose argues is increasingly the case in the life sciences, or how Shostak (2005) has observed with the

emergence of the field of Toxicogenomics. Equally, Abby Lippman's now famous discussion of 'geneticization' (Lippman, 1991, p. 11) could be applied here, in which the genetic increasingly defines the way we see and explain health and disease.

This supports the well-rooted discourse associated with progression in science and medicine marked by paradigm shifts (Kuhn, 1962), where 'regimes of truth' (Foucault, 1980) develop, change and usurp predecessors over time. Theorists argue where once pioneers in anatomy and pathology such as Bichat and Vesalius or Virchow after them, pinpointed the locus of health, disease and illness within the pathophysiology of the body (Foucault, 1963), the current regime of truth increasingly focuses the medical gaze at the molecular level (Rose, 2001). Clearly aspects of this ring true; in the UK increasing resources are dedicated to genetic and genomic research, stemming from political support in the 2003 genetics White Paper: *Our Inheritance Our Future*, through to the substantial £300 million investment in the Genomics England 100,000 Genomes Project .

This is equally true for medical training. At the same time as genetics is gaining prominence in the undergraduate curriculum of medical students in the UK (Challen et al 2005; General Medical Council, 2015), anatomical pathology has been relegated to an optional diploma (Certificate of Higher Autopsy Training) for trainee histopathologists (postgraduate), (Joint Committee on Pathology Training, 2010). This in effect means that it is no longer mandatory for pathologists to be trained to conduct full post-mortems.

Whilst political prioritisation, in terms of the allocation of resources and the focus of training will have great implications for the future of the health care system in the UK, current approaches to the diagnosis and treatment of ICC's remains a multi-disciplinary endeavour. There persists a value within multiple disciplinary approaches to the problem of SADS, where pathological explanations are accepted alongside genetic within the medico-legal – clinical system. Thus, SADS is considered a matter of death and life. SADS is the concern of pathologists investigating sudden unexplained deaths as part of the

coroner's investigation. SADS is equally a concern for clinicians diagnosing and treating patients potentially at risk of sudden death in terms of information about previous sudden deaths in the family. Indeed, as was shown by Teare (1958), information yielded from the dead can be used in the diagnosis and treatment of the living.



## 1.2 Sociology of the Professional Management of Death

Death and life are not so easily separable, as Foucault famously put it:

‘It is at death that disease and life speak their truth’

(Foucault, 1973, p. 145)

When this is contextualised within our current understanding of genetics and inheritance this quote gains reverence, in that information from the dead can have direct implications for the deceased individual’s bloodline. Thus, life and death in the family pedigree are considered a continuation in the genetics clinic. Whilst many discipline defining studies have focussed upon medical professionalism in clinical practice (Bosk, 1979; Becker et al 1961; Freidson, 1970a) as well as medical and legal professionalism in the practice of death investigators (Timmermans, 2006), no study has tracked the continuation between life and death through the organisation of a professional system.

The professionalization of death has long been synonymous with the modernisation of medicine (Foucault, 1973). Although the profession of the coroner was established long before this, formally recognised in 1194 in the Articles of Ayre (Matthews, 2014), the main duty of coroner at that time was the collection of taxes owed to the crown, with the investigation of deaths undertaken as a way to establish how much was owed (Spitz and Fisher, 1987). Investigating the medical cause of death in specific cases arose much later in the Coroners Act 1887. This adaptation of the professional role of the coroner developed out of the bureaucratisation of death in the UK in the form of the Registration Act 1837, which made it mandatory to register particular details about death, such as the place and medical cause of death. The 1837 Act is considered by many to represent the birth of statistical population monitoring (Higgs, 2001), which developed out of a concern that

record keeping to that date had been ineffective in accounting for epidemics such as cholera. This marks the shift from death being accepted as unavoidable, to a time in which the pathological origin of death offered hope for the sustenance and prolongation of life (Airès, 1977). Thus the professionalization of death through the development of the modern coroners system was less about death and more about what death could tell us about life. Indeed the majority of studies focussing on death professionals highlight this aspect of their role (Timmermans, 2006, 2005; Prior, 1985, 1989). Atkinson (1978) refers to this as the medical professional identity of the coroner, with the main purpose of monitoring epidemics or other public health concerns. Similarly, Hanzlick (2006) reported that Medical Examiners' offices in the USA increasingly employ epidemiologists with the function of integrating health monitoring directly into the role of the death investigator. Timmermans (2006) explains that the very process of maintaining jurisdiction over the categorisation of death serves the living. He gives the example of SIDS (Sudden Infant Death Syndrome), explaining how coroners' actions contributed to large scale health interventions, redefining categories of infant deaths in cases where parents may have previously been implicated. Klinenberg's (2002) *Heat Wave* illustrates how death investigators can be actively involved in the process of ensuring action is taken to prevent public health concerns from continuing. He explains how the Chief Medical Examiner of Cook County concluded that heat contributed to the deaths of 700 people during the heat wave of July 1995 in Chicago. However, as this conclusion puts into question the preparedness of the state to manage extreme conditions the Chief Medical Examiner came under a lot of scrutiny. Thus to ensure his warning was heeded and protocols were put in place to prevent future deaths associated with extreme heat, he compiled medical and scientific evidence to support his claim and ensured every death was processed and documented meticulously. This ultimately led to the state accepting the medical examiner's claim and developing new emergency measures. This public health role of the coroner is represented within coroner's law, in the UK, Canada and Australia. Moore

(2016) studies the public health and safety function of the coroner in New Zealand, in which she positions coroner's recommendations as an important resource for policy makers. In the UK changes to the Coroners and Justice Act 2009 gave coroners the authority to construct reports pertaining to circumstances of a death which if changed or highlighted could serve to prevent future deaths (The Coroners and Justice Act 2009, Schedule 7 para 5; The Coroners (Investigations) Regulations 2013, Regulation 28 and 29).

The coroner's professional role is not only outward facing towards the living in relation to preventable public health concerns, it has commonly been reported that the families of the deceased are positioned at the centre of the coroners service in the UK:

'The Coroners and Justice Act... said that you put the bereaved at the heart of the service that's exactly what we do.'

(Coroner, 9)

Indeed, Atkinson (1978) in his early study of suicide noted how coroners would take family concerns into account before arriving at the verdict of suicide. Whilst it is reported that this is no longer the case (Fincham et al 2011), the stigma associated with suicide is still taken very seriously by coroners:

'You don't want to return a suicide verdict unless you're absolutely certain because the family don't really want the stigma of suicide, I don't think it's right, you've got to be very cautious with suicide. I look at those cases very carefully and the criteria for suicide is beyond reasonable doubt, the criteria for accident is on the balance of probabilities, so you've got to be sure, that's the test. First of all that they did the act, and that when they committed the act they intended the consequences to be the end of their own life, so quite often I'll say well I'm satisfied that they did the act but what was the intention and I'm not certain that it was to kill themselves.'

(Coroner 2)

Charmaz (1976) discusses how coroners and their deputies work to ensure that deaths are presented to family members in such a way as to be considered acceptable and credible. Thus, although the work of the death investigator is commonly positioned as a private role (Timmermans, 2006), it is helpful here to view it as intrinsically public and linked to life, ensuring life is sustained and serving the living. This sentiment is embodied within the motto of the Ontario coroners' service: 'To speak for the dead, to protect the living' (Dalton, 1994). This motto has been adopted by coroners' services across the world (Leslie, 2012).

The connection between life and death is equally present within the practice of clinical genetics. Latimer (2013) positioned the family pedigree as the most important genetic test; this was equally the case in the study reported on here, in which the family pedigree was located as the focal point of Multi-Disciplinary Team meetings (MDT's). There has also been a persistent narrative in the literature considering the genetics of cardiac disease, that patients will report the deterministic narrative of heart disease 'running in the family' (Hall, 2005; Weiner and Martin, 2008; Geelen, Van Hoyweghen and Horstman, 2011).

There is a sense in which heart disease in its many guises has always been genetic, understood by families as such based on a history of premature deaths (Geelen, Van Hoyweghen and Horstman, 2011). Previous deaths in families of the same cause are often considered as some of the most important information held on the family pedigree. Whilst the risk of sudden death and patient reflections upon this take up a great deal of the focus of previous research into SADS related conditions (Hints et al 2009; Christiaans, 2009), no study has examined the relationship between information from the dead and clinical genetics.

At a time when more and more developments in the field of genetics are translated into clinical practice, coupled with clinical genetic testing becoming more cost effective it

becomes important to ask how relevant traditional approaches to genetic conditions are, such as the family pedigree. As well as asking how much impact the translation of new genetic technologies has upon clinical practice and the relationship healthcare professionals within genetics have with other professional groups within and beyond the limits of medical practice. Whilst there is a plethora of research examining the effect of the translation of genetic technologies into clinical practice following the completion of the Human Genome Project (Hedgecoe, 2006; Hall, 2005; Weiner and Martin, 2008) there is little discussion around the impact of genetic testing beyond the realm of medicine. An exception to this comes from Van Hoyweghen (2007), in which she examines the impact of genetic testing and information upon the governance of the life insurance industry. However, she examines the insurance industry's approach to genetic advancements and technologies as distinct to that of the scientific, biomedical and clinical domain from which the technology was developed. This study is more attuned to Hedgecoe's (2004) approach to the translation of genetic technology and knowledge. Whilst Hedgecoe's study remains within the science to clinic dyad, the way he examines the translation of pharmacogenetics into the clinical setting is far more explicitly political. He takes into account the agendas and pressures of both the pharmaceutical companies vying for access to a market as well as the pressures of the clinicians who maintain a focus on providing the best treatment and diagnostic tests in a constrained health care system. By encompassing both approaches, we can see how the understanding and experience each group has of the technology and ultimately the shape the technology takes in the clinic is mutually shaped by both groups, they become inseparable from an analytic perspective. This is an enticing prospect for a study such as this, in that it allows for an examination of understandings and experiences of genetics across different epistemic cultures within the clinical and medico-legal domain. However, it moves beyond a comparative analysis to an intrinsic understanding that the view of genetics held within the medico-legal setting extends out from that held within the clinic. Indeed, part of the function of this research is to

understand the interconnected nature of professional groups working on the problem of SADS in the clinic and the court, as well as understanding what genetics and genetic testing is, is extended out from the clinic.

### 1.3 Genetic (Un)Exceptionalism: Critiquing a Disciplined Understanding of SADS

Many previous studies have examined clinical genetics from a sociological perspective, from the translation of novel genetic technologies into the clinic (Hedgecoe, 2006), to the ethnographic study of clinical genetics practice (Latimer, 2013). However broadly speaking these studies maintain a focus within the bounded world of genetics, although often including the practices of other health care professionals who may also work outside of this field, nurses or researchers for example (Hallowell et al, 2009).

Although research often places the genetic test itself as part of the diagnostic pathway (Latimer, 2013; Will et al, 2010) diminishing its importance as *the* diagnostic tool within this setting, there is a sense in which this research fails to consider clinical genetics as part of a wider medical system (See Rabeharisoa and Bourret (2009) for an exception). With moves in the UK to mainstream clinical genetics within the NHS, it becomes increasingly important to ask where clinical genetics fits within the wider organisation of the health service. These are particularly important questions to ask, as genetic conditions rarely concern solely genetic mutations, they are associated with physiological symptoms, which will have brought the patient to the attention of clinicians in the first place. For example in the field of ICC's a patient/family will be registered with a cardiologist as well as a clinical geneticist. This study in keeping with Will et al. (2010), positions the genetic as unexceptional within the clinical management of patients at potential risk of sudden death, in that it assumes that the genetic carries no more weight than any other explanation of a condition. Indeed genetic testing is presented as carrying less weight than other clinical information with regards to the diagnosis and treatment of the individual patient.

This is not an attempt to devalue commentaries discussing the unique social, legal and ethical issues that can arise through the use/misuse of genetic information, such as the

corpus of work developing from the early proponents of the *geneticization* thesis (Lippman, 1991) which highlight the risks of genetic reductionism, determinism and essentialism (Arribas-Ayllon, 2016). Instead, I focus upon the use of genetic categorisation in interdisciplinary clinical practice more in line with Hedgecoe's (2001) commentary on the use of a narrative 'enlightened geneticization'. He discusses how the grand narratives of genetics are forgone in favour of narratives that prioritise genetic explanations whilst accepting non-genetic factors can have an impact in the aetiology a disease entity.

However, this research will argue that whilst Hedgecoe (2001) presents the process of enlightened geneticization as the subtle prioritisation of genetic explanations, this research keeps more in line with Rabeharisoa and Bourret (2009), who comment how clinical work is performed by biomedical collectives from different disciplines converging their multiple clinical gazes upon the patient. Within this study it is argued that whilst the inherited is accepted, the genetic is only invoked where it is *useful* (Hedgecoe, 2008), with usefulness in this setting relating to the ability to provide information which will inform an intervention or diagnosis in a way more efficient than an existing technology.

Discussions of specialist professionalism (Abbott, 1988) could position this as a setting in which there is competition by professional groups all vying to claim jurisdiction over the diagnosis. However, such arguments are subject to the same claims of reductionalism and essentialism that have dominated critical geneticization discourse. Instead, it is helpful to consider the clinical process of diagnosis as the situated and temporary assemblage of imperfect information (Arribas-Ayllon, 2016) to the point at which useful information is yielded, regardless of the discipline from which it emerged. It is important to note that this ambiguity and imperfection is not a failure or a flaw but part of the process of diagnostic categorisation (Latimer et al 2006).

Equally, this study resists claims that *Medicalization* (Conrad, 1975) has a totalising effect, instead arguing that legal constructions maintain integral importance in the explanatory framework of SADS. This is an important contribution to note in that it positions the legal



cause of death as distinct from the medical entity to which it refers, which emerges due to the distinctions between how medicine and law make facts. Although Latour (2010) claims law and medicine are intrinsically linked by their pursuit for the truth, what the truth is and how the truth is arrived at differs significantly between the two epistemic cultures. Whilst legal and regulatory systems have been explored in terms of their implications on what can and cannot be considered genetic, such as Timmermans and Shostak's (2016) discussion of the regulatory states control over which conditions could be included on new born screening panels in the US, little research considers the impact of legal categorisation on clinical genetics practice.

In accepting, as Arribas-Ayllon (2016) does in his review of *Geneticization*, that the genetic only makes part of clinical diagnostic arsenal, or that genetic information often requires analysis in light of other clinical features (Timmermans and Shostak, 2016), it becomes important to ask how this information is collected, weighted and mobilised in interdisciplinary teams. This will be a primary undertaking of this research. Taking a symmetrical approach to the professional system of the identification, diagnosis and treatment of SADS across medico-legal and medical domains, this research will examine not only how this results in multiple conceptions of the central object but also how these multiple constructions are mobilised alongside other potentially contradictory accounts in an interdisciplinary system. Before discussing how these aims will be practically met in the research design, I will first outline the theoretical considerations which ground this project.

## **Chapter 2 – Theoretical Considerations**

### **2.1 A Relational Understanding of Professionalism**

The primary theoretical considerations which ground this thesis come from the corpus of work broadly defined as professionalism theory. Drawing on this literature, this research aims to examine the how professionals from different epistemic cultures are able to collaborate within an interdisciplinary system, as well as how they share information across boundaries. This is problematic within modern theories of professionalism in which professional groups are in competition to maintain jurisdiction over particular practices and knowledge (Abbott, 1988). But also because of the inevitable problem of how a professional deals with the existential problem of how to deal with the limits of his or her skills, knowledge or abilities (Bosk, 1979). Taken together these two issues create a further conundrum that is: how in a competitive system of professions can an individual or group come to accept the skills, knowledge and ability of others to perform a particular task they cannot themselves fulfil? And how do others within this system know the limits and abilities of each constituent member of the system? Thus, this research aims to discuss how issues of professional legitimacy and credibility over a particular task or knowledge are managed within professional practice.

Interest in these problems arose during a conversation early on in this research with a highly esteemed sociologist who had worked on professionalism in the past. I arrived at his office with an idea for a paper which applied Freidson's (1970a; 1970b; 2001) approach to professionals to the work of the coroner. Although not dismissing the prospect out of hand he did immediately interject: 'Is the coroner even a professional?' Whilst Timmermans (2005; 2006; 2008) effectively argues that the professional authority of the coroner in the US has been steadily declining over recent years and that there is little in the way of structural or institutional infrastructure which supports the coroner as a professional, in the UK the coroner maintains the 'license and mandate' (Hughes, 1971)

to perform specific roles. They maintain this license and mandate despite lacking many of the hallmark characteristics of the professional held within much of the professionalism literature. A critical characteristic of the profession, according to key theorists, is prolonged and specialist training (Goode, 1957), which remains the preserve of the profession itself (Freidson, 2001) as a way of providing closure and restricting access. Indeed the earliest occupations that claimed professional status did so on the basis of a formalised system of training in medieval universities. However, there is no standardised and specialised coronial curriculum. Coroners have to undertake 5 year general legal training to the level of a practicing solicitor to qualify for a senior coroner role (Coroners and Justice Act 2009). Trainee coroners follow training more akin to an apprenticeship where they train on the job with existing senior coroners. Although the Coroners and Justice Act 2009 has formalised this process to some extent, through the introduction of mandatory training days, coroners' services remain locally organised and locally accountable. The impact of this is that the practice of coroners is diversified based upon geographic location. Whilst there is a sense in which this diversity is necessary, based upon the variable needs of each jurisdiction (Coroner 4), this also means there is no standard definition of what the coroner does, and little in the way of coherence between coroners jurisdictions beyond local 'phone a friend' (Coroner 6) networks.

In spite of the inability of the coroner to meet the commonly held criteria of what it means to be a professional, the coroner maintains the licence and mandate over knowledge and practices in relation to a specific subset of deaths. This can be explained by the historic position of the coroner in the UK dating back over 800 years, coupled with the market shelter (Freidson, 1994), constructed through the state guaranteed legal protection of the coroners work from competition, interference and other market related forces (Timmermans, 2008). However, such an explanation relegates the commonly held belief that professions and occupations are in a constant state of flux (Atkinson, 1983). The market shelter explanation offers protection from risks to professional status by

competing groups held within theories of professionalism, put forward by Abbott (1988), as well as protection from market driven developments in the workforce as discussed in Larson's (1977) work on professionalism. However, such explanations ignore the practical elements of professionalism, such as how the professional mobilises the institutionally derived or state mandated jurisdiction they have over a certain form of knowledge or practice, a concern which informed Bosk's (1979) *Forgive and Remember*:

‘To use the vocabulary of Everett C. Hughes (1971), I was interested in a segment of the medical profession exercises its “license” and “mandate.” (p, 3)

The theoretical position this thesis takes in relation to professionalism takes a similar view to Bosk, in that I argue that the market shelter only provides protection if it is maintained by those working underneath it. This understanding assumes that professional authority is flexibly attributed within practice based upon the performance of the professional.

## 2.2 Performativity in Professional Practice

The very practical understanding of what constitutes a professional presented above is derived from elements of theories of professionalism that have been overlooked in recent years but is held in the work of both Hughes (1971) and Freidson (1970b):

‘Professionals profess. They profess to know better than others the nature of certain matters’

(Hughes, 1971, p. 375)

Freidson similarly noted that a profession is a group that:

‘claims to be the most reliable authority on the nature of the reality it deals with’

(Freidson, 1970b, p. xv)

What distinguishes these definitions from others is that they do not emphasise the possession of any form of esoteric knowledge. Instead, they emphasise the ability of the professional to be able to perform the expected characteristics of their profession, as a way of maintaining jurisdiction. This is implicit in Abbott’s (1988) *The System of Professions* in that a major contribution of his work is that professions are inseparable from a wider system of professions, many of which are vying for the same jurisdiction, and thus professionals must work to maintain or gain jurisdiction. However, Abbotts (1988) theory, as well as those of Freidson (1970ab; 2001) and Larson (1977) understate the micro social management of professional authority or jurisdiction in practice, instead focusing their analytical lenses upon broader political and historical considerations (Liu, 2014). The wholesale effect of this focus is the separation of the profession from the professionals. This separation was a maintained concern of Hughes, who emphasised how social understandings are derived from a focus upon interactions (Heath, 1984).

A criticism of a micro social, interactional approach to professionalism, in a way which focuses upon claims of authority through performances of expertise, is that it does not say very much about the profession but only how a professional claims to be a legitimate member of a professional group. However, this work asserts that the accounts the professional produces of the mode and content of his or her work actively shapes the identity and jurisdiction of the profession as a whole, or at least situated perceptions of it. This is held within theories of professionalism which argue that professions possess the power to define the content of their own work and thus shape their own identity (Friedson, 2001). Dingwall (1983) goes as far as to say a key characteristic of the profession is the ability to tell society what is right for it to do as well as how to think about problems which fall under their jurisdiction.

Performative aspects of professionalism contribute to the corpus of theoretical and empirical analyses of professionalism in that although it is commonly claimed that professional authority and status is attributed there is little to say why authority or jurisdiction is attributed within collaborative practice. This is in relation both to the individual as a credible member of an accepted profession as well as the profession as the legitimate group to perform a particular task.

To elaborate on this I will refer to debates from the study of expertise originating from Collins and Evans' (2002) *The Third Wave of Science Studies* paper. This paper was highly contested following its publication due to the realist approach to expertise that it presented. Collins and Evans argue that expertise is a substantive possession of a group of experts which is gained through a process of socialisation within the practices of an expert group. This theory of expertise was contentious because it went against the grain of contemporary science and technology studies approaches, which favoured a social constructivist ontology, with such an approach favouring attributional or relational theories of expertise (Jassanoff, 2003; Carr, 2010). These approaches contested that

credibility and authority over a form of esoteric knowledge was not held by the individual but attributed by the society. However, it is Carr's (2010) review of the literature on expertise that this becomes valuable for studying performativity within interprofessional practice. Carr, in a similar vein to Dingwall (1983), states that expertise is performed and it is this performance that constitutes the construction of reality, it produces 'what is true, valid and valuable within that domain' (Carr, 2010, p. 19). However, Carr also concedes that for such a production to be considered successful the presenter has to be socialised within the esoteric knowledge and practices of the expert group to such an extent that they are able to appear fluent in the language of the group. This explanation combines both realist and attributional theories of expertise into a relational approach where the attribution of expert status is actively negotiated in everyday practices.

Although drawing upon theories of expertise in developing theories of professionalism is not novel in and of itself (Lui, 2014), this research argues that professionalism diverges from expertise in the emphasis on the mobilisation of esoteric forms of knowledge within practice. It is not the claim of possessing expert knowledge but it is the way that the professional creates an account of the specialist knowledge, skills and resources he/she possesses as a way of claiming or maintaining jurisdiction or of claiming their place within the organisation of a professional system<sup>2</sup>.

The divergence I make from this approach is the emphasis I put on the performative accounts produced within interactions. Carr suggests experts are considered as such based upon their fluency in particular esoteric language of a group. Whereas this research argues that the professional claims, and is attributed authority and credibility based upon his/her ability to create an account of skills, knowledge and abilities appropriate to the

---

<sup>2</sup> Division of labour is intentionally omitted here. Although the phrase has become fundamental to sociology, in agreement with Hughes (1971) I find the term unhelpful in the analysis of professional systems due to its emphasis on the divisions, where as throughout this research I have not observed any such divisions within the labour force. There are of course differentiations of functions between groups but practice is never wholly divided.

situation, the role which needs to be fulfilled and the presumed expectations of the audience. This situated identity work (Goffman, 1959) serves to accomplish order amongst professional groups, with each group providing a selective account, serving to position themselves as a member of a particular profession as well as positioning themselves as useful to the broader professional system. Thus it is not necessary or indeed possible for an individual to provide an account of the full extent of their knowledge of a particular discipline, nor would it be appropriate in all instances for a professional to use the practice language of a particular group amongst others who would not understand it.

In light of this theoretical exploration, I will return to the problem set out in the beginning of this chapter: If the coroner does not possess the characteristics of a profession, how do they maintain the licence to practice and mandate to define the nature of their work? How do they claim jurisdiction over the dead? Or perhaps: how do coroners maintain their market shelter? Drawing upon the relational understanding of professionalism developed thus far, the coroner can maintain status as a professional by creating an account in keeping with the attributes of a profession. This is particularly achieved by the coroner through the presentation of a solid collegial unit, not in the sense of a connection via formal training but through the continued reference to the law as a ubiquitous power with which they must adhere. The law constrains the accounts they can produce whilst simultaneously providing credibility to any claim of jurisdiction (Foucault, 1977), even when, in practice, interpretations of the law vary considerably. It must however be emphasised that it is difficult for an individual to have a claim of professionalism accepted without socialisation in the practices and language of a professional domain as without these skills it is difficult to construct a credible performance in line with the expectations of the audience. Although the audiences expectations will vary considerably based upon experience with other professionals, it is assumed that they will have at least a basic understanding of what to expect from a member of the profession that the performer is claiming to be (See Collins and Pinch (2005) for an example of the successful employment



of a professional identity without the prerequisite expertise). The use of the term account becomes useful here in that it not only evokes notions of the production of a performative narrative, but also suggests a relation to accountability, in which if the professional does not live up to expectations they will be held accountable and the authority attributed to them can be re-organised. This is reflected in Garfinkel's (1967) use of the term, in which he emphasises how situated accounts serve to maintain a sense of stability within groups, ensuring that the performer maintains a consistent account of the group he/she claims to be a part of.

This relational approach also aids in resolving a conflict which emerges when considering a social constructivist approach to technology and knowledge (Pinch and Bijker, 1984). This research is in keeping with such an approach and as such develops multiple accounts of SADS and genetic testing based upon different disciplinary experiences (Mol, 2002). This not only reflects the differences between professional groups but also within them. A key finding of this research is that professionals commonly situate their practices in a process of reflexive standardisation (Timmermans, 2015) as a way of best suiting their local agenda's. Practically this results in the heterogeneity of professional groups (Bucher and Strauss, 1961) across settings as well as between individuals within the same setting. Within a relational understanding of professionalism this becomes unproblematic as the professional provides an account of his/her practices based upon the assumptions and needs of the audience and can adjust his/her heterogeneous account to be within the normative expectations.

This also aids in the process of collaboration between groups as it assumes that successful interprofessional practice is based upon a good working knowledge of the other professionals within the system. As such the multiple understandings of the central object which could cause conflict is reduced as accounts of understandings are moulded to fit the situated needs of the professional system. This results in a key assumption that the less

social distance (Simmel, 1950) between professionals the better understanding they will have of what each other does and accounts and practices will best represent the needs of the professional system.

This theoretical approach to professionalism and interprofessional practice informed the design of the research where by participants were not only selected based upon their professional identity but also based upon the extent to which the individual interacted with other members of the professional system which is organised around the problem of SADS. How this research was designed and how the interprofessional system in which SADS is managed was mapped out will be discussed in the following chapter.

### Chapter 3 – Methodology

This chapter serves to discuss how the study was practically achieved through a reflexive process of development. I will firstly discuss the pre-fieldwork stage of this study, discussing how early encounters with professionals working at the clinical and medico-legal 'coal-face' (Hedgecoe, 2004) drastically altered the shape and focus of this research. I will also reflect on how the process of gaining access has informed the theoretical approach discussed in the previous chapter. I will then discuss the substantive design of this research including the problem of attempting to study a professional system which is perceived to be disjointed and inefficient by those working within it, as well as the problem of observing the practice of a technology which is rarely used in practice. The study demographics will follow from this in a section which will not only discuss who the participants are professionally but also who they work with. The relational professional system approach will be carried through to the analysis of the data which will draw upon Timmermans and Tavory's (2012) *Abductive analysis*. I argue not only that the analysis of empirical data cannot be separated from the intellectual and theoretical perspective of the analyst, but also that individual participant accounts should not be separated from others within the situated system in which they work.

### 3.1 Pre-Fieldwork – Getting to Know the Field(s)

A key component of this research is gaining an understanding of the professional system involved in the management of SADS from the referral of the sudden death through to the screening and treatment of family members. However, the structure of the organisation of this system was less than obvious, even to those who work within it. Thus before I began any formal research, access had to be gained across many different professional groups. This was to serve not only to ‘get my foot in the door’, but also to give me an idea of how to frame the research in terms of what the problems and priorities are for those working within this system. The conduct of this pre-field work dramatically changed the shape the research was to take.

Gaining access became an issue early on in both the clinical and medico-legal setting. The hidden nature of coroners work is well documented with Fincham et al. (2012) finding accessing the coroner’s office difficult due to the sensitive nature of their work, particularly in the case of suicide (the focus of Fincham’s research). However when attempting to gain access via telephone calls with a particularly helpful coroner it became clear that coroners do not consider themselves as a hidden professional, quite the contrary, they are a public body and as such are under public scrutiny. This was found to have a great impact on coroners’ willingness to engage with research. Many of the coroners I was able to interview had been, and were currently, involved in high profile cases in which there was immense media attention, not only in relation to the case but also in relation to their practice and their ability to practice<sup>3</sup>. This early conversation with a coroner helped shape how I would approach other coroners, ensuring an emphasis upon anonymity and that I would not request information pertaining to any particular cases. By speaking to this coroner I also drastically changed the direction of the research, from

---

<sup>3</sup> No examples are given here as to preserve the anonymity of the coroners who took part in this research.

focusing on why coroners are not using genetic testing, to asking what it is they do when faced with a SADS related death under the constraints of the coroner's system, as it became clear that genetic testing would be very difficult to justify for the coroner as will be discussed at a later point. As coroners only have a weak professional network, it was difficult to snowball interest from a single coroner. Although attempts were made to disseminate my interest, whereby a coroner announced that I would be requesting participation from coroners across England and Wales, when subsequently contacting coroners none commented that they had heard about my research. This alone offered insight into the organisation of the coroner's system across England and Wales and informed many of my subsequent interactions.

Medical professionals on the other hand were far more willing to participate in the research. Formal access is however controlled through NHS Research and Development structures<sup>4</sup>, the complexity of which is well noted (Reed 2007). Although this process was time consuming, ultimately it offered insight into the workings of research and development departments across 23 NHS trusts in the UK, which although maintain a standardised structure and access point (IRAS), differ in their organisational procedures and requirements. These lessons became invaluable when considering the pressures and constraints of conducting genetics research as part of clinical practice.

During the time it took to gain formal access to the NHS research sites, I was able to gain experience of the work that was undertaken by the professionals who work with SADS from across the broadly medical spectrum. I was able to observe a medico-legal post-mortem as well as having the opportunity to observe 2 days of genetics clinics across two sites and a cardiac genetics multi-disciplinary team meeting (MDT). These observations helped me understand what it is that these professional groups do and who they do it with. The observation of the post-mortem helped me to understand the time and resource

---

<sup>4</sup> Full NHS ethical approval was not required for this study as no patients were involved.

pressures of this setting as well as the objective of the investigation as a distinct from medical practice. Observing the clinics and the MDT served to expand my focus from the external Sociologist viewing the problem as existing between the coroner and the geneticist, to viewing the problem from within the system as involving many other moving parts. This system extended from the clinicians in the field of cardiology and genetics, to the specialist nurses, genetic counsellors and laboratory scientists, all of whom had an integral role in the wider organisation of the professional system. Prior to gaining formal access to any sites I also attended academic cardiac genetics conferences, giving me access to specialist professionals from across the world and through conversation I was able to ascertain who was considered 'the' experts in ICC's by their peers, or more importantly where the centres with the best reputations were. What I gained from all of these preliminary encounters was my lack of knowledge within all of these disciplines to the extent that it took a lot of preliminary work before I could ask any interesting questions. Based on this experience my approach to interviews became far more research oriented. Through my interactions I quickly realised that each professional had very different experiences and approaches to his/her work. This altered my approach to research design from assuming that interview schedules could conform to disciplinary separations, to an approach in which each interview schedule was adapted to each participant. This is seen as a pre-condition to the effective elite interview as identified by Mikecz (2012), in which there is an expectation that the interviewer will have a good knowledge of the interviewee. Although this study does not fully adhere to the definition of the elite interview as is used in political science (See Davies (2001) for an example), it develops ideas from this method in collaboration with others.

These initial interactions not only shaped the focus of the research but also the presentation of the data. Although I would only claim to possess limited 'interactional' expertise (Collins and Evans, 2002) across the domains in which the research was conducted, I did become familiar with the particular terminologies which signified

membership to a particular group. Whilst these experiences did not occur in the pre-fieldwork stage, they did serve to shape subsequent interactions with participants from a particular profession. The first experience occurred during my first interview with a senior coroner of a large inner city area. Before the interview began I handed him the information sheet and consent form, to which he immediately took out his pen and crossed through the title which originally read: 'Genetic Testing for Sudden Arrhythmic Death Syndrome and the British Coronial System'. He continued to amend the heading changing the 'British Coronial System' to 'The Coroners' System of England and Wales' on the basis that: 'There is no such thing as the British Coronial System' (Coroner 1(not direct quote)). This same coroner also interjected during the interview, when asked about coroners' priorities:

'I have a difficulty with your concept that the coroner has a priority. The coroner has statutory duties which he [sic] has to follow. The law doesn't recognise one statutory duty as having priority over others, they all have to be met.'

(Coroner 1)

In subsequent interactions with coroners I ensured I referred to the Coroners' system of England and Wales, as well as ensuring that legal 'duties' was used instead of 'priorities', and this of course informed my understanding of the coroner as a legal professional. Such language and terminology issues emerged throughout the course of the study and care had to be taken that the correct language was used during interactions so that allegiance to a particular group was not presented. Gaining familiarity with the special uses of language is emphasised as an important skill by Becker and Geer (1957) who emphasise that it is not enough to learn the language, the researcher should strive to understand how the language is differentially employed in practice by different groups. Although members of a group will not often make explicit their esoteric language practices, they will react when a term is used incorrectly, and within the interview setting there is little opportunity for

corrective work (Becker and Geer, 1957). How particular conditions were referred to varied between disciplines and care had to be taken to use the native terminology within interactions. A good example of this is Hypertrophic Cardiomyopathy; cardiologists generally refer to this condition as 'Hocum' where as other clinical groups tend to use the acronym HCM and thus care was taken to ensure the correct term was used depending on the audience. Moreover where the terminology remained ambiguous I tended to use the most general terminology, the most noted example of this is SADS. This term, as will be discussed in Chapter 11, can be seen as explicitly political depending on what the term is perceived to represent and thus during interviews I referred initially only to the acronym SADS. This is also reflected in my reluctance to provide a definition of the term throughout the thesis. Avoidance of disciplinary allegiance has followed through to the presentation of this work in that, where possible, I will refer to the terminology used by those with whom I am referring to in context, in doing so I hope to represent the voices of the interviewees (Hedgecoe, 2004).

The preliminary fieldwork process served two related functions; the first was getting to know the professionals who had a special interest in SADS from across a variety of disciplines; and the second was getting to know the epistemic cultures and schemes of practice involved in the system from sudden death to screening and treatment. This had a great influence on who was selected as a participant as well as where was chosen as a research site.



### 3.2 Spaces of Practice and Co-Construction

In *The Social Organisation of Death*, Prior (1989) defines the focus of his work as:

‘the forms of knowledge and schemes of social practice which surround the dead from the moment death is announced until the moment of disposal’

(Prior, 1989, p. x)

In this study, I aim to focus on the epistemic cultures and professional practices surrounding SADS from the moment of sudden death through to the screening, genetic testing and treatment of family members. However, like Prior, there is a clear starting point of this system, but there is little in the way of designating an end point nor is this system neatly bounded. By reflecting upon this, it becomes important to ask how the analysts gaze came to focus on the parts of this system that it did. Any boundaries are of course an artefact of the constraints of the research process; no one can know or observe every aspect of such a complex system and thus the researcher must apply boundaries where there are none. The boundaries of the system were applied on the practical basis of what I was able to access, as well as what was considered as the boundaries of this system by those who worked within it.

Ultimately, this led to defining a focus upon specific professional groups working within the medico-legal or clinical domain and which have a specialist interest in SADS broadly defined. As such the study will focus upon 7 professional groups (plus two supplementary groups) which, not exclusively, constitute the professional organisation of the identification diagnosis and treatment of SADS. The demographics of the interview participants are as follows:

<b>Profession</b>	<b>Number</b>
Coroner	10
Pathologist	7
Cardiologist	7
Clinical Geneticist	4
Specialist Nurse	3
Genetic Counsellor	4
Laboratory Geneticist	1
Family Service Review Organisation	1
<b>Total</b>	<b>40</b>

Figure 2.

All of these participants were selected either due to a specialist expertise in ICC's or SADS, or in the case of the coroners, based upon an interest in their public health role or their proximity and reported working relations with centres of clinical expertise. Although effort was taken to identify 'the' experts in SADS from the respective disciplines, this was not the primary recruitment strategy. Instead, the primary focus was to identify professional systems which had a proven track record of interaction and effective working relations in relation to the identification, diagnosis and treatment of SADS. Whilst this will not provide a representative understanding of the professional organisation of SADS across England and Wales, it will provide an understanding of how professionals work together, rather than where they do not. This study focuses upon 8 sites across England and Wales with an average of 4 participants per site:

<b>Site A</b>	<b>Site B</b>	<b>Site C</b>	<b>Site D</b>	<b>Site E</b>	<b>Site F</b>	<b>Site G</b>	<b>Site H</b>
Senior Coroner X2	Senior Coroner X2	Senior Coroner	Senior Coroner	Pathologist	Clinical Geneticist	Senior Coroner	Pathologist X2
Pathologist	Cardiologist	Pathologist	Pathologist	Cardiologist X2	Genetic Counsellor X2	Cardiologist	Scientific Review Organisation
Cardiologist	Clinical Geneticist	Cardiologist		Clinical Geneticist	Laboratory Geneticist	Clinical Geneticist	
Paediatric Cardiologist	Specialist Nurse	Specialist Nurse		Genetic Counsellor X2		Specialist Nurse	

Figure 3.

These sites tend to be located around a large tertiary NHS centre, which has a specialist ICC service. However, this is not exclusive, with some sites having multiple NHS trusts located within. The politics of working across NHS trusts creates problems of data and resource sharing and thus the measures taken by professionals to overcome this issue were important to represent. In this sense, this study takes influence from Annemarie Mol's (2002) *Body Multiple*, which takes the system of making atherosclerosis as a whole within a Dutch University Hospital, studying the interweaving accounts of how atherosclerosis is made in practice across a range of disciplines. This has been a pre-occupation of Science and Technology Studies for some time, not the study of the professional and social processes which make up an effective system, but the spaces of interdisciplinary interaction or the boundaries between disciplines. Indeed discussions of the *boundary object* (Star and Griesemer, 1989) and *trading zones* (Galison, 1997) will be drawn upon when examining this broad interprofessional system. However by studying intersected accounts and collaborative interprofessional practice, the focus will be less upon the separation of professional groups into bounded epistemic cultures, and more upon the integration of these groups in a professional system which serves to co-construct what SADS is, how it is mobilised, as well as the technologies designed to identify it. Work in Science and Technology Studies under the category of SCOT (Social Construction of Technology) use *co-construction* to describe the process by which a technology and its users are mutually shaped (Oudshoorn and Pinch 2003; Woolgar, 1990); this research extends this notion beyond technology to the mutual shaping of what SADS is as well as the appropriate practices in relation to SADS.

The multi-site approach also offers the opportunity to distinguish between local professional systems and the broader national professional system, which connects practice across expert sites, as well as discussing actor relations with institutions. Such an approach aids in establishing the effect of the macro on the micro and vice versa. Although organisation of the professional management of SADS at the local and national level rests

upon micro-social relations it also encompasses social relations between individual actors and institutional entities such as NHS commissioning bodies or the Ministry of Justice. For example clinicians at elite institutions will consider the broad economic and practical impact of the work they are doing, as well as the situated consequences, this meta-perspective is available to these clinicians due to their active presence and influence at the local, national, clinical and infrastructural level. Moreover, to simply focus on micro-social relations risks separating this professional system from the society in which it is embedded.

### 3.3 Research Design

A key concern arising early on in this research was how to capture the organisation of a professional system that does not exist in any confined space. The majority of the coroners that I have met throughout the course of this research will have had no direct contact with a clinical geneticist, let alone a laboratory scientist, thus it would be difficult to observe such a system in practice. This realisation became more profound due to the perceived rarity of suspected SADS related deaths, as well as the ethical issues associated with using the sudden death of a young person as a research opportunity. Thus following a case/family through the professional process from sudden death to clinical screening was quickly eliminated as a possible method. Following such a fragmented and disconnected system would also be practically unachievable within the scope of this project as many cases take years from sudden death to the screening of family members and a family has to endure many intermediary stages prior to specialist consultation, as can be seen in the timeline in the preface of this thesis. Thus, the decision was taken to employ an interview based methodology as a way of providing accounts not only of practice but also of the issues which inform practice. All interviews were conducted in the professional's place of work, generally in their personal office, situating the interview in the professional work environment, but also enabling access to props which were employed by participants to explain particular details or provide evidence to support a claim. For example, coroners would often bring out case files pertaining to SADS related deaths they had investigated as a way of showing their practices. This was equally the case for pathologists, however the evidence of their work they shared was most frequently photographic evidence of cardiac dissections or histopathology slides as a way of showing where they looked and what they saw, or did not see in the case of a channelopathy. Observations were also undertaken at key points in this professional system at which interaction occurs between professional groups; these were the coroner's inquest across multiple locations in England and Wales

(N: 15), cardiac genetics multi-disciplinary team meetings (MDT's) (N: 8), and diagnostic genetics laboratory practice (1 day).

The interview aspect of this study was designed taking into consideration aspects of both expert and elite interviews. The expert interview is a common trope of science and technology studies across multiple fields of knowledge; such as the physical (Collins, 2004), biomedical (Hedgecoe, 2004) and Economic sciences (MacKenzie, 2006). This method of enquiry is utilised to gain access to specialist forms of esoteric knowledge, this is equally the case here. However, this study does not attempt to weigh in on the debates over who is considered an expert, which have concerned Science and Technology Studies for some time (Collins and Evans, 2002). Instead, I take a liberal view that a professional will have some form of expertise over the domain in which they practice. Although many of the participants in this study would be considered world renowned authorities in ICC's or in cardiac genetics, this does not devalue the expertise of the specialist nurse or the genetic counsellor, thus expertise and expert authority are considered as distinguishable. The influence that is taken from elite interviewing is the deferential approach taken to all interviews as well as the expansive pre-interview preparation conducted for each participant (Mikecz, 2012). This deferential approach extended to supplementary telephone interviews conducted with family members of the deceased accessed via a charity (N:4). This decision was taken as a way to resolve issues of studying up or down in Anthropology (Nader, 1972), in that this study argues that any participant possesses knowledge that the researcher does not, and thus the participant maintains power as they control access to the object of enquiry. These interviews were designed to gain access to the process that families went through following a sudden death traversing the space between medico-legal and clinical worlds. Deferring to the expertise of the participant ensured that a relativistic approach was maintained, this was important due to the often conflicting accounts received from different participants describing the same process or technology, such an approach enabled an understanding which asserted that all

explanations were equally correct to the participant. Tailored pre-interview preparation was equally important, not only in that it ensured that the correct language was used but also because it enabled the activation of particular stocks of knowledge by the participant, depending on the line of questioning (Holstein and Gubrium, 1995). An example of this can be seen in an interview with a cardiac pathologist. At the beginning of this interview, I wanted an account of the professional practices of this pathologist within her particular trust and how this compared to her medico-legal work. To garner an in depth response to this general question, I presented myself as a naive researcher with little knowledge of the role of the cardiac pathologist, as I wanted an account of the mundane practices which could be taken for granted if I was assumed to possess a level of expertise in pathology. Following this line of enquiry, I wanted to know specific details of how this pathologist managed the tension associated with putting the physiological cause of death on the death certificate or the genetic syndrome thought to cause the pathological changes. The question asked in this instance was designed to show a level of understanding of the aetiology of cardiac disease as a way of yielding answers containing in depth medical explanations, the question asked was:

‘Say you had someone die with Marfan syndrome, would you put Marfan syndrome as the cause of death or would you put aortic root aneurism?’

(Researcher quote, Cardiac Pathologist 6)

This changed the tone of the interview and enabled access to specialist stocks of knowledge pertaining to the particularities of pathological diagnosis.

Much like Hedgecoe’s (2004) study of pharmacogenetics, this study approaches the professional organisation of SADS as explicitly political at the broad system level in that issues of resource rationing and commissioning mechanisms are considered to be of particular concern to professionals who work in this system. However, this political approach is extended to the interpersonal interactions that constitute local systems, how

authority and meaning are contested and constructed within situated interactions. As such, a key aim of the interviews was to gain accounts not only of the interviewee's practices and the politics surrounding these issues, but also their understandings of the practices of those they work with, as well gaining an insight into how they gained such an understanding. Such a technique requires participants to reflect upon their role within a wider professional system, asking why they do what they do in relation to the work of others. This also enables the exploration of accounts of how dominant discourse emerges in practice.

The interviews also allowed participants to reflect upon observed practices, by taking a systematic approach to study sites, it was often the case that I would conduct interviews with individuals that I had previously observed within a MDT or at an inquest. This enabled an exploration of the meanings which were applied to practices. As the observations were far from ethnographic, in that they provided a mere snapshot of a particular form of practice at a particular period of time, the interview gave access to accounts of the context which preceded the observed practices. This adds depth to the study in that it enables the analyst to ask questions of why something happened as opposed to simply presenting what happened. Of course the why questions are answered from the single professional perspective, thus the advantage of a systematic approach to professional systems is that I was able to contrast accounts provided by participants. This approach enabled the unpicking of socio-cultural influences upon actors in constructing their accounts, and indeed upon the practices themselves.

The observational aspect of this research should not however be considered as supplementary to the interview data, a study drawing upon observations of coroners inquests would provide an original contribution to the limited research in this field in and of itself. In that, previous studies examining death investigation broadly speaking seem to stop short of the coroners' inquest (Prior, 1989; Timmermans, 2006; Atkinson, 1978).



Much of this work aims to provide an examination of the social construction of the categorisation and causation of suspicious, unexpected deaths, yet they provide no empirical account of the space in which such constructions are formulated and formalised within the performance of the coroners' court. This is something that is explored in Chapter 8. The technique of observing legal practice in the court setting has been undertaken across a variety of legal court settings, from the traffic court (Brickey and Miller, 1975) through to the Crown Court (Scheffer, 2010). The inquests observed varied considerably in focus, I did not search out inquests pertaining to potentially SADS related deaths as this would be impractical with coroners reporting to only see few such deaths per year in large jurisdictions and a few times in their entire career in smaller areas. As such I observed all inquests I was able to on the day/days visiting a particular coroner's area to conduct interviews, and visits were organised around particular days in which many inquests were scheduled. There was an even split between inquests concluded as natural causes as those concluded as unnatural, with conclusions of suicides constituting the entire unnatural group. In addition to these two categories there were a small number of inquests which were adjourned based upon insufficient evidence or to await evidence. There was also one inquest which was concluded as unascertained which will be discussed in detail in Chapter 8. Although this research is interested in coroners' practices in relation to natural deaths, the practice and structure of inquests pertaining to unnatural deaths was consistent with the inquests pertaining to natural deaths. Thus, the decision was made to draw upon the whole corpus of inquest observations gathered.

The cardiac genetics MDT's (N: 8) were selected as a site of observation as they offer the rare opportunity to see interdisciplinarity in action. Although modern clinical practice is increasingly defined by multi-disciplinary patient management (Sanders and Harrison, 2008; Nancarrow and Borthwick, 2005; Liberati et al 2016; McNeil et al, 2013), spaces in which multiple disciplines come together to make decisions about patient management are relatively rare. These MDT's were separated into two groups by disease grouping;

cardiomyopathies and channelopathies. Both MDT's were held in the same room in a large city hospital and both were routinely timetabled at the same time on the same day on a monthly basis. The attendee's generally remained the same across both groups with the exception of the specialist nurses who organised and managed the MDT's and thus only attended the MDT's they ran. The typical professional demographics of these meetings are as follows: Specialist nurse (N: 1-2), Clinical Geneticist (N:1), Cardiologist (N:1-2), Paediatric Cardiologist (N:1), Genetic Counsellor (N: 1-2). In addition to these regular attendee's there were on occasion others who attended, such as a laboratory geneticist as well as cardiologists from outside of the NHS trust in which the meeting was held. Around 10-20 cases were presented at each MDT meeting and each lasted from 1-3 hours.

These two sites of observation offered the opportunity to take extensive notes, which is a difficulty associated with observational methods (Emerson et al, 2011), particularly concerning the reactive effect of taking notes, a problem Goffman solves by suggesting brief notes should be taken 'off phase' (Goffman, 1989, p. 130). This was not necessary in either of these two settings. The coroners' court is an open forum, anyone can attend, this often means that journalists are present at inquests, to the extent that in one small jurisdiction the senior coroner was on a first name basis with journalists from the local newspapers. This meant that although the coroners knew I was observing the inquests any behaviour alteration based upon the presence of an observer's eye would have occurred regardless of whether I was there or not. As a result of this as well as the dramatic organisation of the court, the observations of the inquest are presented as a public performance. Within the MDT setting it is common for members to be taking notes for the minutes, indeed I submitted my notes to the nurse charged with taking minutes. The result of this comfort with an observer taking notes meant that my notes were detailed and comprehensive, this is aided by the compartmentalised timeframe in which the meetings and inquests were held meaning that I did not have to be selective in what was noted. I thus followed a comprehensive strategy to note taking (Wolfinger, 2002) in which I was

able to capture reasonably detailed accounts of interactions within the space observed which have proved invaluable in understanding interprofessional practice.

This comprehensive strategy was also employed within the laboratory observation.

However, the focus of this observation was not on the interactions between professionals working within the lab, instead I used the laboratory observation as an opportunity to gain an understanding of the practices and politics of the diagnostic laboratory. To enable such an understanding I requested a tour of the laboratory by the manager who also works as a laboratory geneticist and thus has a knowledge of the economic politics associated with running a lab as well as the everyday exigencies of working as a member of a lab. Within this setting note taking was not optional, when asked whether it was okay if I took notes as we went around the lab, the geneticist replied: 'I would be offended if you didn't'. This is a very different kind of observation to the traditional laboratory ethnography made popular by Latour and Woolgar (1979), in that it provided a quick and messy method of gaining a situated account of the practices of the laboratory. Whilst I had many conversations with the scientist who gave me the tour prior to my visit to the lab as well as other members of the lab there was little in the way of emersion into the practices of the lab. Instead what this offered was a methodical walk through what happens when a sample is sent in to the lab; from logging the sample in the system using anonymous sample codes; to DNA extraction and amplification; through to the analysis of the results and the construction of the report to be sent out to clinicians. This was an important insight as it offered an alternative narrative to the rhythm of the lab offered by formal pathways or descriptions of laboratory practice in scientific papers. This observation also served to situate the interview with the laboratory scientist conducted immediately after the observation.

Taken as a whole this research was pragmatically designed to get the greatest understanding in terms of depth and breadth of the organisation and practices of a professional system which was little understood. The aim to understand this professional

system is followed through to the analysis stage in which the data were organised systematically to reflect the interconnected nature of professional practice.

### 3.4 Analysis and Data Organisation

Prior to discussing the practical accomplishment of analysing the data, it is important to first position what the data are considered to represent. Both the observational data and the interview data are to be considered a performative account (Garfinkel, 1967), constructed with a rhetorical intention. These accounts are productive, they produce and re-produce the cultures and practices they claim to represent. For example during an interaction during an MDT, a clinician's account of a patient interaction shapes the understanding that the rest of the members of the group have of the patient. Equally, during an interview, a participant may construct an account of their own professional practice and this is the understanding of the social world that the interviewer has access to. However, for this study, which adopts a broadly social constructivist epistemology, the extent to which the accounts represent practice is not questioned, because the focus is primarily on how these professionals create meaning and the impact this has upon the meaning of objects and practices held by others. Such an approach reduces the impact of the common criticism aimed at interview based studies which comes under the umbrella of the 'attitudinal fallacy' (Jerolmack and Kahn, 2013), which state that the correlation between reports of behaviour and actual practice is somewhat disconnected. Indeed, it is precisely such notions which shape the approach to accounts taken here.

Data analysis took on board many of the concerns outlined by Timmermans and Tavory (2012; 2014), who find the inductive approach favoured by proponents of a grounded theory (Glaser and Strauss, 1967) unrealistic. Instead, they present an abductive approach to data analysis in which empirical data and theory are in dialogue with one another. The rationalisation for this is that a social analyst cannot be separated from the social world that he/she inhabits, and sociologists are socialised in a wide corpus of social theories. It thus becomes unrealistic to expect a researcher not to draw upon his/her professional disciplinary socialisation when designing research, creating hypotheses and analysing

data. Social constructivist sociologists hold this to be true for those we observe, for example this research discusses how, what SADS is, is multiply constructed by different professionals based partly upon their disciplinary perspective, why should the same not be held true for Sociologists? Such an approach does not hark back to the deductive approaches which instigated the development of grounded theory in the first place (Timmermans and Tavory, 2012), instead it relies on a sceptical appraisal of theory in light of empirical data and relies on a broad knowledge of theories as a way of situating claims and thus developing theory. This approach is pragmatic in that it does not strive for the unrealistic goal of induction set by grounded theory, instead positioning researchers as social actors themselves. It also helps to explain the linearity of developments in different camps within Sociology, in which scholars aim to continue the conversation or disciplinary perspective started by their predecessors, if only to refute theoretical claims based upon empirical evidence.

An abductive approach to data analysis requires a coding regime which is in constant dialogue with theoretical concerns. For example, this research was fore grounded by a concern that the definition of what and who a professional was in the theoretical literature did not represent who was considered a professional and thus attributed authority and credibility in practice. When it came to the analysis of the data, I initially focussed upon instances in which participants discussed professional identity and authority within a wider professional system and the impact this had upon practices. This concern would not have been simply induced from an analysis of the data from a neutral point. Conflict arising due to the agenda to maintain or gain professional jurisdiction is a key concern for modern theories of professionalism (Abbott, 1988), thus the data were approached in dialogue with this concern. This is not to say that I looked to prove or disprove this notion but I was aware that such jurisdictional conflicts had been commented on consistently since Abbott published his *System of Professions* (1988), thus I coded where professionals interacted and how they asserted authority over particular knowledge or practice claims.

Although I did not see, nor was I told of any jurisdictional conflict, such a theoretical device helped to frame my analytic lens. Such a process of abduction does not however exist at a single stage, data are unpicked initially taking an approach more attuned to the inductive grounded theory approach, then re-picked and re-shuffled in the context previous literature and theoretical texts.

Based upon a preoccupation with how professional systems work, the data were organised as to reflect the interactions between participants across interviews and observations. Taking a systematic approach to interview participant recruitment at a site level means that participants were selected based upon the knowledge that they worked with other interview participants in the study. What this meant in practice was that participants would often comment on the practice of people they work with who I had also interviewed<sup>5</sup>. Equally, interview participants would comment on a practice which I had observed, for example a specialist nurse may talk about MDT practice or organisation. This enabled the mapping of data based upon the connections accounts had with each other. The method by which these maps were constituted broadly follows Clarke's (2003) three cartographic approaches in her *situational analysis*: (Situational Maps; Social worlds/arenas maps; and positional maps). Described above is the situational mapping technique, this technique was of key importance as a mode of examining contrasting accounts of objects and practices as well as understanding the accounts participants constructed of each other. Additionally the data were organised by what Clarke refers to as *social worlds/arenas*, however I have simply referred to this as organising the data by professional group. This approach was taken as it offered an insight to disciplinary differences in accounts given of particular objects and practices this helps in examining important issues such as how useful genetic testing is to different professional groups. Finally, positional mapping techniques were employed as a mechanism for examining the

---

<sup>5</sup> Participants were aware that I would be conducting many interviews within their location and would be asking about how they work in relation to SADS, however care was taken to ensure that I did not reveal the identity of participants during interviews unless given explicit permission.

above two maps in that it helped in understanding whether an account of a particular position was constructed based upon disciplinary identity or local situated networks. By taking a situated analysis approach, I was able to map not only local networks of interaction and connectivity but also national networks as I was able to establish where or who participants referred to during interviews as a way of mapping common networks and interactions. Through such a technique I have been able to ascertain the extent of local coroners 'phone a friend' networks as well as the means by which ICC clinics contact external genetics laboratories. Such an insight has far broadened the analytical lens of this study in that it has developed to encompass aspects of the professional network which would be considered less relevant from an external standpoint, but based upon interview accounts these aspects could be further explored. The diagnostic genetics laboratory is one such case, and as can be seen in Chapter 7, the practices of this setting are integral to the understandings of the politics and practices of making SADS genetic. Thus, an integral aspect of the analytic regime of this study is that no account given is separated from the broader organisation of the system from which it had emerged.

The same care has gone into the practical process of analysing the data, although computer assisted analysis software has helped develop qualitative research, I opted to analyse the data manually. Although this approach was undoubtedly time consuming, it was considered necessary as to ensure the context was maintained within the transcript, thus the coded extracts were not separated from the context in which they were spoken. The intention of such an approach was to attempt to keep the participants voice present as opposed to the coded category, this is reflected in the length of the quotations given within the text. In the next chapter, I begin to report on the findings of the study. I will firstly examine the political and socio-economic space in which genetic testing for ICC's was translated as a way of grounding this technology within the day-to-day exigencies of the NHS clinical system.



## **Part I: Genetic Testing for Inherited Cardiac Conditions in the NHS**

### **Chapter 4: Political Translation of Genetic Testing for Inherited Cardiac Conditions**

Part I of this thesis examines the clinical space in which genetic testing for ICC's is organised. However, before this clinical space is explored, it is helpful to outline the process by which this clinical space and the genetic technologies used within this space came to take their current shape. This is referred to as the political translation of genetic testing, it concerns the process by which the space in which genetic testing will be employed is carved out of the existing clinical infrastructure as well as how political and economic constraints are negotiated in the translation of novel medical technologies. It is this concern that constitutes the focus of this chapter.

Studies examining translational research in biomedicine from medical sociology and science and technology studies often draw upon the narrative from 'bench to bedside' (Martin et al, 2008; Wainwright et al, 2006; Kohli-Laven et al 2011; Timmermans, 2015; Chen, 2009). This narrative is followed through in policy and research funding initiatives in the UK, US and Europe. For instance, the 2007 settlement for the MRC included a £132 million fund for translational research (Medical Research Council, 2008) which included six new translational research centres across England. Translational research has also figured heavily in NIH (National Institute of Health) and European 7<sup>th</sup> Framework Programme funding initiatives (Watts, 2010). Although there is agreement that translation serves to reduce the gap between basic science research and clinical application, beyond this there is variation and ambiguity in what constitutes translation (Watts, 2010). Moreover, translation is often invoked within biomedical research grant applications as a

way to improve chances of obtaining grant support (Wainwright et al, 2006), which further blurs what translation means in practice.

By focussing on the translation between the first two pillars of translation defined by the European Society for Translational Medicine (Cohrs et al, 2014); the bench to the bedside, much previous sociological research ignores the third pillar; community. Instead, previous research examines how the characteristics of the technology in the research setting becomes aligned with the needs and regulatory constraints of the clinical setting or vice versa (Timmermans, 2015), this has been referred to as a process of co-construction (Shostak, 2005). In contrast, although the transition from bench to bedside will not be ignored in this thesis, this chapter will focus on the political and economic aspects of the translation of genetic testing for ICC's from the research setting to clinical application. This detours from other scholarship examining translational medicine in that I will examine how the infrastructure to support the translation of a technology is engineered prior to, and built upon following its translation, in a similar vein to that reported by Hedgecoe (2004) in his examination of the translation of pharmacogenetic therapies into the clinic. This builds on previous literature in that I situate the translational agenda within a constrained NHS, which practically means that even where researchers and clinicians are aligned, technologies may not come into practice due to political or economic constraints. Furthermore, the shape and availability of the genetic testing will be presented as entrenched within a system of politics defined by commercial competition and disparate funding and commissioning regimes.

By drawing upon previous research examining the politics of national health service commissioning (Klein, 2010) and of the clinical availability and use of novel medical, genetic technologies (Hedgecoe, 2004) this chapter will discuss the process of translating genetic testing for inherited cardiac conditions (ICC's) into an explicitly political system. In doing so I will also discuss how professionals negotiate the constraints of such a system in

a pragmatic way; compromising on the technical cutting edge as a way of providing an efficient service as responsible, accountable clinicians.

## 4.1 Free Samples

In 2001 the Department of Health announced a £10 million fund to set up a network of genetics knowledge parks as part of the strategy to make the UK a leader in genetic technology aimed at speeding up the process from 'blue skies research to clinical application' (Burton, 2003 p.1). This investment marked a major political push for clinical genetics in the UK with the Department of Health white paper 'Our inheritance, our future – realising the potential of genetics in the NHS' (Department of Health, 2003) being released a year after the Genetics Knowledge Parks were established. The Oxford Genetics Knowledge Park was one of six centres across the UK and focussed on the use of molecular genetics in the clinical setting (Bonn, 2005). One of the priorities of this park was an attempt to understand the genetic mechanisms that led to sudden cardiac death. A project was set up early on that accepted referrals of patients and samples from across the UK, providing genetic analysis, looking at specific single genes for mutations associated or thought to be associated with conditions such as HCM and LQTS as well as other conditions thought to cause sudden cardiac death. This meant that clinical genetics services across the UK could access this service free of charge, only having to provide clinical information to the lab for their database. Although the results from this service were not as good as expected, it was free to clinicians and was the only service available at the time, as was recalled by a clinician:

'...around that time the Oxford molecular genetics lab, they had the money from the Oxford knowledge gene park. That was the money given by the government to a few major centres to really revitalise the genetics services and bring them to a much more modern footing. So many of us did this, there was no cost implication to use and so ... for a good 3 years or 4 years we didn't have any difficulty and we were sending samples and ... we were receiving results. However, the testing was based on gene by gene basis it was not like a collective testing arrangement [gene

panel]. The technology was very, very old fashioned so we had a very low pick up rate and we didn't know whether we were getting the most sophisticated mutation report, whether it was really disease causing or not...'

(Geneticist 3)

The provision of free technology in the clinical setting as a way of garnering interest and 'changing testing cultures' (Hedgecoe, 2004), has been presented in the past, as a commercially driven process led by large pharmaceutical companies with a stake in the technologies success (See Hedgecoe (2004) for an example of this in relation to the provision of HER2 testing). It would be easy to say that this situation was different, this was a Department of Health initiative, they had no commercially viable drug to be marketed off the back of this testing. However, there are economic and competitive rationalities at the heart of this programme of free testing and there is a rhetoric of supply and demand which results from this marketing strategy.

This Laboratory in Oxford served the Welsh cardio-genetics service for around 5 years. However, a problem with relying on research as a clinical service is that it is not indefinite, funding runs out at some point, this will be discussed in some detail in Chapter 6.

Much in the same way as Roche was able in relation to HER2 testing (Hedgecoe, 2004), the Lab in Oxford succeeding in the goal of increasing public and professional awareness of genetic testing for ICC's (Bonn, 2005) creating public pressure to provide genetic testing for SADS conditions through the NHS. Following this, there was a formal acknowledgement of the Department of Health prioritisation of genetic testing for ICC's published in Chapter 8 of the coronary heart disease national service framework on Arrhythmias and Sudden Cardiac Death (Department of Health, 2005). This document specifically advocated the use of genetic testing to identify those at risk of sudden cardiac death. This marked the stabilisation, not of the technology as this was achieved much

earlier<sup>6</sup>, but of the political sphere in which cardiac genetic testing was to be used. By providing clinical access to the technology for 4 or 5 years, the Oxford lab was able to show that genetic testing for ICC's was effective as a clinical tool. The availability of genetic testing also shaped the clinical genetics services, institutionalising testing and creating public and professional expectations of its availability, which became more noted when this expectation could no longer be fulfilled:

'Towards the end of 2009 the Oxford lab stopped doing [free genetic testing]. We were quite disrupted. We faced a professional dilemma, we had provided the service both clinical and the testing, in fact we had improved the service and by that time the awareness and visibility of the cardiac genetics service both locally and nationally had increased and as you know, we started hosting this [symposium]. We only had 2 round of symposia which helped to establish [centre] as a centre of excellence in cardio-genetics but paradoxically we were not able to provide testing.'

(Clinical Geneticist, 4)

Thus the publication of Chapter 8 marked the acceptance and public prioritisation of genetic testing as means of combating the problem of continuing sudden death in the families – genetic testing had become “indispensable and unavoidable”<sup>7</sup> (Gieryn, 2002, p, 43). Following the construction of this document, in the period from 2005-2009 a lot of work went into developing ICC services across the country. William McKenna and his team in the Heart Hospital constructed the first practical document discussing the construction of ICC services in 2007, titled; 'Proposal for the Establishment of Inherited Cardiovascular Condition Centres' (McKenna et al 2007). This document, known as the 'blueprint' (Burton

---

<sup>6</sup> This type of single gene testing had been developed over a long period of time, first successfully used in the early 1990's to establish a causal link between HCM and mutations on  $\beta$  cardiac myosin heavy-chain gene (Watkins et al 1992).

<sup>7</sup> Although genetic testing was seen as indispensable to ICC services this did not guarantee its commissioning as will be discussed in relation to Wales in the following section.

et al 2009) by the Department of Health, outlines guidance for the establishment of 10 specialist centres around England designated to ICC's, specifically advocating the use of genetic testing for families. During this time the cardiology and cardiac genetics community drew together a consensus statement (Garratt et al, 2008) emphasising the importance of genetic testing for ICC's and situations in which testing should be used. This was developed by a 'core set' (Collins, 1981) of experts in the UK thus providing legitimisation of the technology and the expectation for it to be used in the clinic.

Following this the PHG foundation was commissioned to conduct a needs assessment and service review of ICC services, concluding with 16 recommendations for ICC services, including 4 specifically focussed upon commissioning of services. They were then asked to produce ICC service commissioning guidelines for the Department of Health, this document, amongst other recommendations, suggests that the availability of genetic testing across the UK was of key importance, and that this testing should be provided by services listed in the UK Genetic Testing Network (UKGTN) (Burton et al, 2009). Much of the guidance given by the PHG Foundation was adopted by NHS England in their commissioning contract for Inherited Cardiac Conditions Services (NHS England, 2013c).

The economic rationalities for offering the technology for free for a fixed period served as an effective business plan, although there was little hostility to cardiac genetic testing from the clinical community, as there was for HER2 testing (Hedgecoe, 2004), there was not the clinical culture of testing, nor was there the clinical infrastructure. Prior to the Gene Knowledge Park funding there were no ICC clinics in Britain (there were services dealing with these conditions under another name), and there was no genetic testing for ICC's available through the NHS. By introducing the technology for free, limited though it was, instigated a culture shift, which was organised in such a way by the Department of Health, that not only were clinics happy to continue to use the technology, they adopted the means of developing and improving it. Genetic testing became part of their identity as a professional community. The early proponents for the technology became 'heterogeneous

engineers' (Law, 1987) tasked with dissociating practices which were in conflict with their agenda, replacing them with those in support of their mission. This is an extremely complex multifaceted process, one cannot simply change practices and expect no opposition – a culture change is required to effectively achieve this, from very micro, situated systems to much broader national institutionalised practices. This is true even where as in this case there are no dissenting groups to the overall aim.



## 4.2 Engineering through Robots

This process needs further unpicking through the use of a situated example. When the knowledge parks first emerged, genetic testing was undertaken within a research laboratory, this laboratory had the benefit of a large amount of funding from the Department of Health as described earlier, amongst other sources. However, for genetic testing to be successfully translated to the NHS setting, it needed to be possible within the NHS infrastructure. I asked a leading Geneticist about how this occurred at his centre, where there was both a research and NHS lab. The first process involved in translating a technology to the NHS setting was described as streamlining:

‘So the first thing was robotics, firstly this streamlined and automated the process, which made things a lot cheaper, and this also reduced the chance of human error because robots rarely make mistakes. Meaning that before they would double or triple check everything at every stage, where as with the robots, they just check them (the samples) before they go in’.

(Geneticist 1)

By making the actual process of genetic testing cheaper, it becomes more attractive to the NHS diagnostic setting, which has far more limited resources and would ultimately have to deal with a larger volume of samples without incurring errors. However to get this system into practice work had to be done to change the way in which genetic testing was undertaken in the diagnostic lab. Training was provided for the NHS diagnostic lab and the NHS lab scientists were given access to the robotics in the research lab, this had the function of changing the professional cultural practices:

‘This is really a cultural thing, we had to change the culture of the lab. They used to do it in a different way, and now everything we do with robotics, we go to the NHS lab because they now know more than we do, they are the experts.’

(Geneticist 1)

This was a process of assimilation; previous practices were dissociated and transformed into practices aligned with priorities of those invested in the development of a clinical genetics infrastructure in the UK health service:

‘Before there was a great fear of missing something , but now with the higher throughput there is the need to be more efficient, but it is hard to change from one culture to another [i.e. from checking to not checking].

Also this fear of missing something... new tests test for a lot of genes and with less certainty so a lot of patients come back negative and that is ok.’

(Geneticist 1)

The priorities in this case reflected the presumed growth in demand for genetic testing as well as technological advances, such as next generation sequencing, which were emerging within the research domain and had the potential to have drastic implications in the field of diagnostic genetics. These advances required a much higher through put, which yielded a substantially larger amount of data (the negotiation of which will be discussed in Chapter 7). Although robotics in the lab is taken for granted, for example when the process of Sanger sequencing was shown to me the scientist simply stated: “the PCR is done by the robots for the Sanger sequencing”, there was a notion of how this “changed the tempo of the lab” (Lab Scientist 1). The robots themselves are not the issue that is at stake here, it is the changes in professional cultural practices that were needed to accommodate the use of robots, and thus the higher throughput of data. Some of the scientists there reminisced of the time when they could focus on one condition and one patient throughout the process,

however the introduction of robotics and a larger volume of work means that they now have to focus on single tasks within the process. The genetics lab has become a disassembling, re-assembling and interpretation line (See Chapter 7). Workers become the experts in one aspect of the process. This is most notable for the Laboratory Geneticists who spend little to no time in the 'wet lab', instead spending their time analysing the output on a computer. For example, one geneticist admitted that she did not even know how to use the next generation sequencer, and would only come into the 'wet lab' to use the old technology the new technicians could not. There was also a sentiment where the scientists missed doing 'real science' (Laboratory Scientist 1). This is not to say that those at ground level dissent the trajectory campaigned for by the genetics community and the department of health. There is a maintained discourse of the greater good that the changes and greater efficiency enable:

'I liked the old ways, it was like 'real science'. That's not saying that the job is any less interesting, it is interesting in different ways, we can do so much more now. And the implications are far greater and we know the implications for diagnosis.'

(Laboratory Scientist 1)

Thus, the community's agendas and priorities have been transformed in keeping with the heterogeneous engineers. Although the means by which the ends is achieved has consequences for the practices of those at the service end of genetic testing, there has been a culture change and the mission to extend the scope of this testing has been absorbed within the laboratories' culture.

The NHS lab scientists became proficient in robotic technologies but they also became invested. The initial investment from the research lab has paid dividend by engineering an expert culture that not only enables testing to be undertaken within the NHS, but also creates an accessible source of expertise in medical robotics that is able to advance the field. This was reportedly intentional, the Geneticist 'knew' how genetic technologies were

developing, he knew that next generation sequencing technology required a much higher throughput of information and he knew that the NHS setting would ultimately bear the brunt of the increased work load. The research lab in this case, through the provision of training and technology actively shaped the NHS diagnostic genetics service in line with their priorities and the way in which they perceived genetics to be advancing in the UK. The NHS lab also has a stake in the development of genetics now they are the experts in robotics, they are at the cutting edge of a field that runs in parallel to research genetics, they thus have an incentive to support the progression of both fields.

This can equally be applied to the provision of free testing in the UK. By offering testing for free it became expected clinically, as the technology had reached stability in the scientific community. But it also established the pipeline for testing, for some time the Oxford lab was the only provider of this testing in the UK, and they remain the main provider of cardiomyopathy genetic testing due to established relationships with clinicians across the UK: 'I mean we are the longest running lab in the UK' (Laboratory Scientist 1). Even when the lab had to start charging for the tests, centres continued to use their services even though, as shown earlier there was a perception that the technology was limited. This maintained the flow of testing in the UK, however at a broader level those within the core set of cardiac genetics in the UK also had the agenda to improve the clinical genetics infrastructure in the UK. It was expected that regional labs would be established in the wake of the initial gene knowledge park investment where testing for ICC's could be carried out. This was instilled within the 'Blueprint' (Burton et al 2009) document with regards to the establishment of 10 centres across the UK, but there was also pragmatic economic reasoning behind it:

'Other labs like [location]... if it's more cost effective for them to do it in house than to send it out, then that makes sense for them to do that. But then if they are offering it at a lower price you might get other people sending their testing.

Actually I think most of the labs that do their own testing only do it for their own region.'

(Laboratory Scientist 1)

This also improves the genetics infrastructure in the UK, in line with the enterprise of the heterogeneous engineers. This not only extends the size of group invested in the development of clinical genetics infrastructure in the UK, but introduces an element of competition and diversification. The competitive element serves to drive up efficiency 'offering the most genes for the lowest price' (Lab Scientist 1) and diversification creates hubs of expertise, for example Oxford remains the historic hub of expertise for cardiomyopathies, but Manchester is considered expert in arrhythmia conditions. The more specialised one is, the more they can know or learn about less and less so diversification and competition together serves to advance the field of cardiac genetics, as was envisaged by the department of health and those early pioneers in cardiac genetics.

Networks of clinicians were established who were invested in the advancement of the technology, formal guidance and regulation was put in place to govern this development. Cultural practices at local and national levels were moulded in line with this enterprise, they became invested in this new genetics, themselves becoming the experts, moving the field on in, not insignificant ways. The technology itself was dictated from the outset but has been developed subsequently from this model (i.e. larger panels and the move to next generation sequencing, whole exome (WES) and genome sequencing (WGS)). From the Genetic Knowledge Park, the system has become entrenched within the culture of clinical genetics, clinical ICC services have emerged primarily due to this initiative. However although testing became a cultural expectation within this field, its use, as with all medical technologies remains contingent upon funding, i.e. if it is not commissioned it will not be available. Whilst there was intensive campaigning to show the importance of this technology clinically (Burton et al, 2009; Garratt et al, 2008; Priori, 2013), some were

unable to commission testing locally before the money ran out. Although the end of the free testing was known about unlike in the case of HER2 testing by Roche (Hedgecoe, 2004), this still caused considerable anxiety for some now established ICC and cardiac genetics services, such as in Wales.

### 4.3 Genetics *Lite*

By the time that the money allocated to Oxford had ran out much of the rest of England had commissioned ICC services which provided genetic testing, and if a service was not available locally patients could be referred elsewhere (Health and Social Care Act, 2013). At a time when genetic testing was the accepted norm for ICC services across Britain, Wales could not offer any testing for ICC's beyond Marfan syndrome<sup>8</sup> for a period of about 7 or 8 years. ICC clinics continued to take patients and bank DNA for a time when they could provide testing:

'We were not able to provide the testing... we managed to continue our professional activity, we received patients, we were banking DNA, we were doing everything that was needed except we could not send samples to Oxford.'

(Clinical Geneticist 3.)

This was extremely problematic not least because there was the public expectation to be able to receive genetic testing, as it had been available for a number of years, but also due to the lack of options for patients in Wales to receive treatment elsewhere. When I queried a cardiologist about referring patients to centres that did offer extensive testing such as Oxford or Manchester, he responded:

'We don't have any national services that we can access as such, in other words we don't have funding to refer people for testing.'

(Cardiologist 6)

---

<sup>8</sup> Although Marfan syndrome is not categorised as an inherited cardiac condition, as a disease of the connective tissue it does involve cardiac tissue and can result in Sudden Death caused by changes to the aorta such as aneurism. This can lead to aortic dissection, which causes immediate death in about 40% of patients.

In Wales, medical genetics commissioning is governed by WHSSC (Welsh Health Specialist Services Committee), and the genetics service in Wales runs as the All Wales Medical Genetics Service (AWMGS). Welsh patients, much like English patients, can be referred to any medical genetics service in Wales. However, the process of referral into England is problematic. The WHSSC referral guidance makes it clear that referral to English services for specialist conditions should only happen in extraordinary cases, on an individual basis (NHS Wales, 2011). As a resolution to a consistent demand, the process of Individual Patient Funding Requests (IPFR) is not appropriate. This led to increasing public pressure and pressure from clinicians working in Wales who became organised:

'We set up a group called Welsh Inherited Cardiac Conditions Interest Group... this group was eventually taken over by the Welsh Cardiovascular Society which is... a very big lobby of cardiologists in Wales so then I approached them and they agreed to officially recognise the interest group and made that part of the Welsh Cardiological Society. I was then able to lobby to do testing, for the issue at a whole Wales level through the platform of the Welsh Cardiological Society... eventually we were able to attract the Welsh Specialised Services Committee attention.'

(Clinical Geneticist 3)

This attempt at lobbying, although ultimately successful necessitated great compromise. Early business plans aimed at achieving equitable services to those in England, including a dedicated genetics lab, were viewed as over ambitious. As a cardiologist recollected, this bid was rejected and a stripped down bid was put together:

'I'd had this idea of actually going for this *genetics lite* approach, where we refined the bid down really to the minimum to get things moving and took out all the labs and extra technicians and one thing and another... We got a small team together...and we sat down and wrote a very limited bid for testing family members with a diagnosis of either long qt or hypertrophic cardiomyopathy, on



the basis that we could make an economic case by doing those, because by ruling out some people in those families from testing we were saving money further down the line in the system by not having to carry on clinically screening those people forever and a day. We basically said here is a situation where if you put some money in, it will give you a return in the long term... Although people have been very keen for genetic testing for all sorts of things most of the guidance... only says that clinical genetic testing, as distinct from doing it because you're interested or as a research question, probably really is only definitely [recommended] in the long qt and Hocum groups so that was why we targeted those... We put a bid in for 60 grand a year and that was successful.'

(Cardiologist 6)

This bid was not only genetics *lite* in terms of the provision of testing allowing for, at the time around 50 tests to be undertaken per year (excluding cascade tests which are cheaper), but also because the clinicians involved were unable to secure funding for their time and effort. It is also worth noting that this kind of service has been designed and commissioned based upon above all else the economic rationale of removing potential patients from the clinical system thus saving resources. It also enabled the much cheaper cascade screening, where by family members of a phenotype and genotype positive patient with LQTS or HCM could receive targeted genetic testing, looking for only the single family gene mutation. This technique is substantially cheaper than the gene panel based tests used on index patients:

'You just need a very focussed testing for a fraction of the cost. For example the whole panel testing costs £560, at a reduced rate with the Oxford Lab... so the testing for a single gene, single mutation in a family would be just around £100, and if you have more members coming up in the same family you could have multiple members in one run, you can have 3 or 4 members from the same family

the cost will come down, because the lab time, the lab persons time would be minimal, and the reagents will also be shared so the testing cost to the lab would be quite small.'

(Clinical geneticist 3.)

In the public imagination genetics instils imagery of the hypermodern Laboratory; clean, sharp, new and expensive, however in reality much clinical genetics work is underfunded, located within some building or wing towards the back of a large tertiary hospital.

Although Latimer (2013) comments on the immediate adjustment of expectations upon arrival within a clinical genetics department at a large teaching hospital, little work has been conducted investigating the impact of austerity upon genetics services. Perhaps *Genetics lite* is the future model of commissioning genetics services. What will follow is an examination of the impact of this approach as conveyed by the professionals that work within this system, defined at all stages by a lack of resources as epitomised by this Specialist nurse:

'It's amazing what you can do with fresh air isn't it?'

(Specialist Nurse 2)

I have discussed thus far the macro level rationing of priority setting and resource allocation surrounding the clinical translation of genetic testing for ICC patients. I will now discuss the micro level rationing (Klein, Day and Redmayne,1996) of how the resources are used in practice. This goes beyond much of the other research discussing the rationing of scarce resources (Prior 2001; Hedgecoe, 2007) as I will discuss how the very structure of the service embodies the frugality of the modern NHS (Klein, 2010). This will show that despite public and political pressure to adopt certain technologies and practices within this local culture the engineering (Law, 1987) of services must be considered as contingent and thus unpredictable in terms of outcomes. Even with the most compliant

community, completely invested in the progression of genetic testing, economic constraints and a competitive commissioning environment mean that any attempts at progression (relatively speaking) will come under scrutiny, and for every emerging speciality or technology there will be others vying for the same resource pot (Pathologist 3). Thus, pragmatic efforts are taken that compromise on the cutting edge but allow at least some service to exist.

The design of the service has efficiency embedded within it. Efforts were taken to ensure that the testing process would slot into the existing infrastructure of ICC services:

### All Wales Cardiac-Genetics Patient (Proband) Referral Pathway

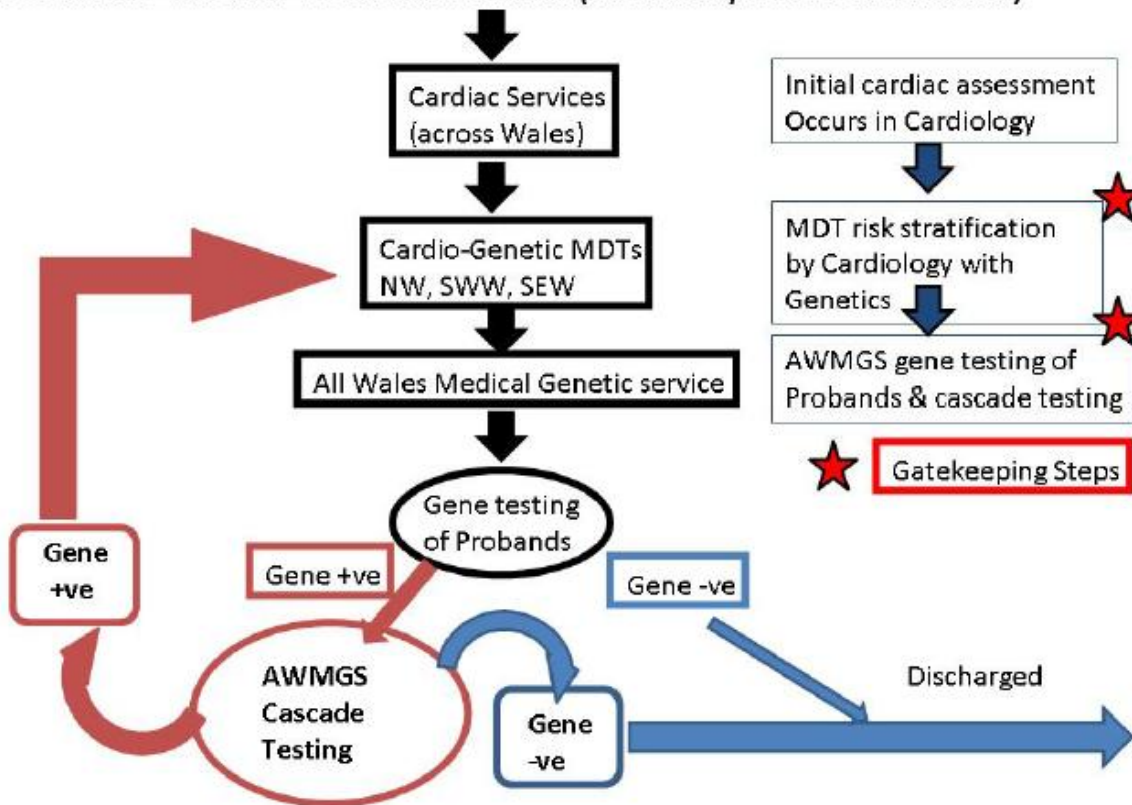

(Figure 4. WHSSC, 2012: Patient Referral Pathway)

As this diagram shows, genetic testing mechanisms became embedded within the existing ICC service. Patients still first had to have an initial Cardiac assessment, and patients/families were still presented at the Cardio-Genetic MDT. Although not present on this diagram the lab used for genetic testing also remained the same as the relationships

were already established enabling some leeway on the price of the test. Effort was also taken to ensure that there was no inappropriate use of scarce resources, the main way in which this is achieved is through the MDT. Although these were occurring on a regular basis prior to the funding of genetic testing, they now fulfil an additional purpose, to sanction genetic testing. For a genetic test to be undertaken within this service it must first be approved by the MDT. This model of approving genetic testing ensures that inappropriate referrals are avoided. The criteria for testing is based on 'the probability of a gene positive result... assessed as at least 50%' (WHSSC 2012 p4). Although this rationing decision appears to preclude the possibility of autonomy amongst clinicians with regards to clinical decision making, opposing Hedgecoe's (2007) argument, instead it facilitates a collective autonomy, in that discussions can often centre around how to make the most out of limited resources and how to push the constraints and limitations of the system.

This chapter has not only served to introduce the complex process of translating a technology from the research to the clinical setting through a process of social stabilization. A process defined by manipulation by 'heterogeneous engineers' (Law, 1987), moulding the clinical genetics arena through the provision of free testing for a period of time, enculturating the practice as a standard of ICC services, embedded within commissioning guidelines and community best practice documents. This process was also marked by incredible flexibility, after all one of the aims was to establish and cement a genetic testing infrastructure for practice, to ensure testing could be embedded within current clinical practices. This chapter has also shown that contrary to the ethic of equity embedded within the NHS, the honey moon period of free testing was short lived and the harsh reality of making an economic and clinical case for services has resulted in services that are underfunded and working with outdated technology. This serves to emphasise that advances in medical technology do not necessarily equal advancements in clinical services. Pragmatic rationing decisions have to be made, both at the commissioning level and at the clinical decision making level which ultimately means that the cutting edge is rarely

available as a standard in the clinic. This next chapter will discuss how genetic testing is rationed during day-to-day clinical decision making as well as examining the techniques used to overcome limitations both in terms of resources and the commissioned technology.

## **Chapter 5: Ruling in, Ruling Out, Risk and Rationing**

This chapter is aligned with Pinch's et al. (1992) understanding of the weak programme of health economics. This programme positions clinical decision making as contingent upon the situated political and economic environment. This weak-programme allows for seemingly poor economic rationalisations, based on the principle that the technology has to be used in practice, situated amongst a whole plethora of other practices. Within the clinical genetics setting, these include firmly embedded practices such as 'phenotyping' of the patient via ECG, or the construction of the family pedigree. This is sewn into the very fabric of the Welsh system at the point of commissioning. This rationale is also embedded within clinical decision making, the genetic test is not presented as a diagnostic intervention out of context, it is surrounded by considerations of its implications for clinical interventions as well as considerations for the wider family, in addition to economic rationalisations.

Although there is a standardised algorithm for the use of the genetic test this is rarely used in practice. Instead rationing decisions are made on a case-by-case basis by the MDT and careful considerations are made as to whether to 'rule in' or 'rule out' (Hughes and Griffiths, 1997) genetic testing for the patient and their family.

## 5.1 Ruling in: 'Barn Doors' and 'Good Goers'

'Ruling in' the patient for genetic testing is a rationing exercise to determine who deserves (Hughes and Griffiths, 1997) the test based upon relative risk and economic resources available. Ruling in rationing discourse dominates decision making with regards to the provision of genetic testing within the Cardiac Genetic MDT. The number and heterogeneity of patients far outweighs the number of genetic tests that the All Wales Medical Genetics Service can afford or are commissioned to undertake (79 index case tests and 47 cascade tests, limited mainly to LQTS and HCM for the period 2013/14 (Anderson, 2014)). Clinicians selectively apply the test based on the strength of the clinical phenotype, or the likelihood that they will find a mutation held in the panel that they use. Those with the strong phenotype are the 'Barn Doors', the obvious phenotypes that the clinicians can clearly identify through clinical tests, such as the presentation of a QTc interval on an ECG >480 msec, a history of syncope and a family history of LQTS (Schwartz, 1993). They are as obvious as a barn door to a professional trained to read an ECG. This presentation would give clinicians confidence that the patient definitely has LQTS, and thus a level of confidence is achieved that they will find a known mutation in the patient. This was explicitly explored at a cardiomyopathy MDT, at which a Clinical Geneticist stated that they: 'don't refer the patient to genetics if they haven't got a confirmed diagnosis' (MDT3).

At first sight, this seems counter intuitive; to test for a condition the patient is 'known' to have<sup>9</sup>. To appraise this, one must first unpick the purpose of genetic testing. It should be noted that 'the purpose' represented here is not presented normatively, but as the purpose in context, that is, in the context of this ICC service, the political and economic space in which this service is located and the agenda of the clinicians present in this space:

---

<sup>9</sup> What counts as having or not having the condition is not fixed. What is referred to here as 'known to have' will differ from the definition of having the condition at a different point in time. This will most certainly differ to other professionals' definition of 'having the condition', this multiplicity will be explored in great detail in Part III.

‘The whole purpose of testing a patient who has got long qt syndrome or hypertrophic cardiomyopathy... the result would benefit in targeted selection of other at risk family members, not to the person. Frankly speaking, you do not require genetic testing to make a diagnosis, you can make the same diagnosis of these conditions by ECG or [ajmaline] challenge<sup>10</sup>... the main advantage was that once you know the mutation ... in the person, then all first degree relatives... could be offered the genetic assessment.’

(Geneticist 3)

The clinical management of the patient would not change on the basis of results from a genetic test. This was emphasised repeatedly, ‘Phenotype is King’ (Cardiologist, 6):

‘It doesn’t matter what gene your carrying, if you’re not expressing any phenotypic features your risk is probably none...the phenotype tends to trump things, if the phenotype is strongly positive then it doesn’t matter that the gene test comes back negative, they still have the condition, you just haven’t found it...’

(Cardiologist, 3)

This repositions the test outside of the realms of a diagnostic tool, instead locates it as a risk stratification device, not for the single patient, as is represented in Prior’s (2001) study of rationing, but for the whole family. Positioning the clinical gaze on the whole family rather than the single individual, whose risk has already been stratified during the clinical assessment, calls for a re-assessment of the classical ideal of modern medicine that ‘Physicians should do whatever is in the best interests of their *individual* patient’ (Khushf, 1999:43). Instead arguing for an extended responsibility to the whole effected pedigree, this integral point to this thesis will be further explored at a later point (Chapter 12). This

---

<sup>10</sup> Ajmaline challenge is an ECG provocation test, in which the clinician injects ajmaline into a patient with suspected Brugada syndrome. The ajmaline can provoke the Brugada ECG which may lay dormant in the patient.



is an essentially reductionist and deterministic rationale. Although this is ethically complex (see literature on geneticization for further explanation eg. Lippman, 1991; Arribas-Ayllon, 2015), I find it difficult to criticise. I argue that this is not a reduction but an extension, extending the implications of a single individual (index case) potentially to other family members, whilst maintaining a focus on the clinical management of the *individual* patient.

Before examining how risk is assessed by clinicians in this context, what risk relates to should first be defined. Risk in the field of ICC's almost universally relates to the likelihood of a person suddenly dropping dead of a fatal arrhythmia (Papadakis et al, 2009) and this risk is assessed against the bench mark of 'population level risk' (Geneticist, 3), this varies between conditions, but is taken collectively as around 1.8 in 100,000 (Papadakis et al 2009)<sup>11</sup>. As stratifying rationing decisions is intimately connected with the perception of the family, at the most shallow level resources are rationed based on the size of the family, i.e. bigger family equals more people potentially at risk of sudden death. For example, many cases are initially introduced in the MDT meeting as the X family as being a 'very big family' (MDT2). When employed alone, the Family as a risk category serves as a blunt quantitative tool that has economic rationale at the centre:

'The whole panel testing costs £560 at a reduced agreed rate with the Lab, [where as] the testing for a single mutation in a family would be around £100... if you have more members in the same family you could have a multiple member... In one run you could have 3 or 4 members of the same family, the cost will come down because the lab time would be minimal and then the reagents will also be shared so the testing cost to the lab would be quite small. That would also feed back to the family and cost saving to the lab.'

(Clinical Geneticist. 3)

---

<sup>11</sup> The validity of this figure will be questioned in Chapter 10.

The savings here are clear. When constructing or discussing a family pedigree, the tree that emerges is not simply a translation of the ancestry of the patient/proband and their family (Latimer, 2013), the biography and pathology of the family is also considered. The main risk stratifying piece of information yielded from this exploration into the family's past is the presence of sudden death, explained or otherwise. Any sudden death in the family history is put under scrutiny, for example during an MDT a geneticist outlines a suspicious history:

'...there were a few things, there was a death by boating accident in the family, as well as a RTA [Road Traffic Accident] and a drowning – she also has an uncle in [location] who was sent to [lab] for the 4 gene panel, which came back negative... We have DNA for her.'

(MDT3)

This patient only had a very mildly positive phenotype for LQTS, she presented a borderline long QTc<sup>12</sup> on adrenaline challenge (which is an arrhythmia provocation test), which the attending cardiologist queried as this was the only finding. However, following the presentation of such a devastating family history it was decided that she could receive the updated genetic panel. History of sudden death trumps all other categories, even in this case where there has been a negative genetic test in the family and the patient only has a 'mild' presentation with no symptoms. The patient here is presented as 'deserving' because of this devastating family history (Hughes and Griffiths, 1997), as family rhetoric has been found to be a powerful moral tool (Gubrium and Lynot, 1985), which is used in this case to strengthen a case for 'ruling in' based on weak clinical evidence. One stage down from sudden death, symptoms from across the family are considered, whether this be an actual diagnosis, or whether it is reports of suspicious symptoms in other family

---

<sup>12</sup> QTc refers to the corrected measurement of the patients QT interval as read from their ECG and applying the Schwartz criteria (Schwartz et al, 1993).

members; such as episodes of syncope or palpitations. Thus, the family of the patient discussed is very much part of the clinical picture for the assessment of risk, in terms of the patient themselves and the wider family. A holistic approach to family assessment serves as a form of risk assessment, identifying the 'high risk' group for the purpose of allocating scarce resources (Prior, 2001). However contrary to research examining this risk categorisation work, in the case of cardiac genetic testing the 'high risk' are not defined in terms of single patients but of families. This is partly an economic rationale as cascade screening is a fraction of the cost of single patient screening, but also because the risk categorisation of one family member is intimately linked with the risk, symptoms and pathologies of other family members. Considerations of the whole family can give clues as to the presentation of the condition in others particularly in cases where the phenotype has yet to present in a patient.

However the lack of a family does not immediately rule out a patient. There are temporal considerations of the patient's future; if the patient was to consider starting a family, they would be offered the genetic test, cases are brought to the MDT specifically because of this (MDT4). This further develops the extension of individual patient responsibility, it is clear that potential family members are also considered as clinically relevant for the purpose of risk assessment and rationing genetic tests. These are temporal dimensions, considering the potential future risk to the continued pedigree based upon the risky family mutation.

## 5.2 Ruling out

When a patient has no family they are precluded from having genetic testing based on the rationale that their individual risk is already being managed; during an MDT when testing is suggested for a patient without a family the clinical geneticist dismisses the request: “Well I don’t know, maybe academic testing because there is no family” (MDT2). Here, although the protocol advocates the use of genetic testing there will be little benefit from the test, thus the expenditure of limited resources cannot be justified in this case. This is not overt ‘ruling out’ but it instead ruling out by attrition (Hughes and Griffiths, 1997), the clinicians are not, not giving the test because the patient is somehow undeserving, but due to economic constraints there are other categories of patients who are more deserving. There is a sense that some families are downgraded due to social characteristics, however the family is never fully ruled out of the clinical picture, their status is instead relegated in terms of importance when compared to other families. Members of these families, “DNR” (Do Not Respond) (MDT3), these are the patients who do not attend their clinical appointments, nor can they be contacted easily over the telephone. This causes some annoyance for the attending clinicians, nurses and genetic counsellors, which can relegate the status of the family within the service. Relegation is only relative to other risk assessment devices, such as the presence of the phenotype in the patient or family, or a history of sudden death, if these are not present the family may get ruled out of further investigations:

‘Cardiologist: There is a family history of sudden death [patients] grandfather [on mothers side] died at the age of 44 and [other family members] have ICD’s [internal cardioverter defibrillator]. The problem with this family is that they do not engage, contact has been attempted on numerous occasions for cardiology and genetics clinical appointments. [Patient] is phenotype negative as is his mother, so

the risk to this family from the mother down to her children is expected to be low and because both of them are phenotype negative they don't have the condition so do not need to be seen.

Geneticist 1: well if the mother doesn't have it...

Nurse: I tried to get the post-mortem report but I couldn't access it through the mortuary and the family isn't engaging.'

(MDT5)

Although the family in this case does have some risk factors, such as the family history of sudden death, they are ruled out from further intervention because of their relatively low risk (phenotype negative) paired with their lack of engagement. They are positioned as undeserving (Hughes and Griffiths, 1997) where, as shown in an earlier example, patients could be ruled in for genetic testing. It must be emphasised that this kind of decision will only be made with regards to those patient on the fence between risk categories. For those families where there is a moderate to high risk of sudden death, but who do not engage, the clinical team use more imaginative techniques to engage and will not rule them out. When a patient was at risk of 'dropping dead' the MDT devises plans to ensure engagement:

'Cardiologist: whatever we do we need to act carefully because he could die suddenly. [The context of his non engagement was then outlined] He had a loop recorder fitted, and when the battery ran out he went to have it replaced and the cardiologist who did it looked at his notes... and said 'we really ought to put in a pacemaker'. This caused the patient to get scared and he never returned and now it transpires that he probably needs a defib [Implantable Cardioverter-Defibrillator ICD] so he really needs to come in.'

The geneticist then suggested that they should get both [Patient] and his brother in again emphasising the priority to get samples for genetic testing to confirm the gene.

'Cardiologist: yes but we should approach them separately.

Geneticist: I remember that the brother travels a lot for work so it might be tricky to get him in to clinic.

...

Cardiologist: try and co-ordinate getting a genetic counsellor to [brother of the patient]'s next ICD check to get consent for genetic testing [followed by a joke saying 'tell him we need to take the blood or the ICD will stop working'].

(MDT4)

These were two separate patients at the same MDT, both of whom had a history of non-engagement and both are in the high risk category, the first patient needing an ICD and the second already having one, but not engaging with genetics so his family remain at risk. For the first patient engagement with family members is attempted as a way to access the index patient presented. This is a common technique presented at the MDT, often by emphasising risk to children as a way of engaging parents. The second technique used requires quite a large investment, by re-organising cardiology clinical dates, ensuring a genetic counsellor could attend. This contradicts the understanding that those who would be classed as undeserving for social reasons would receive less resources as Hughes and Griffiths (1997) suggest, instead this device should be taken as relative to the risk of sudden death to the patient or their family members. All rationing devices for ruling a patient or family in or out are interconnected with other rationing tools and other clinical decisions and spaces beyond the MDT, this is why the 'weak programme' put forward by Pinch et al. (1992) is so useful in this case. It allows for rationing decisions to be contingent and relative to the situated individual case, the context, and the other decisions

that are made. There is not a single point or decision that is made that rules in or out a patient for genetic testing, it is an accumulation of economic decisions, risk stratification and professional and situational standards and norms.

In clinical genetic terms, ruling out is not strictly a negative rationing device. Within ICC services ruling out is the goal, to rule a patient out is to say that they are at no more risk than the general population. The ruling out of a patient can only occur in the context of the family pedigree, in relation to the family mutation. Ruling out in this context does not relate to receiving the genetic test in the first place, in fact the genetic test is a prerequisite of being ruled out and is considered by many as the major benefit of genetic testing for SADS conditions (All cardiologists and Geneticists agreed upon this during interviews). This is alluded to in the explanation of the purpose of genetic testing given earlier:

‘...the main advantage was that once you know the mutation ... in the person, then all first degree relatives... could be offered the genetic assessment.’

(Geneticist 3)

This is known as cascade screening, where by testing for the single gene in each first degree family member is undertaken, as explained earlier this is substantially more efficient than conducting ‘the full panel’ on every member of the family. The benefit of this is that if a family members’ screen comes back negative for the mutation found in the index case (the patient who presented first and had the initial genetic test), the clinicians can assert that they do not have the condition and are not at risk:

‘...where the gene testing comes in really helpful is removing the 50%<sup>13</sup> negatives out of the system... being able to tell someone at the age of 25 that the gene that is in your family that has killed a lot of family members you don’t have it. It means

---

<sup>13</sup> This 50% relates to Mendelian patterns of inheritance. The most common ICC’s are considered to be autosomal dominant giving 1<sup>st</sup> degree family members of a sufferer a 50% chance of inheriting the condition. However, in practice the presentation seems to be closer to 40% because of issues such as incomplete penetrance.

that 10 years from now they aren't worrying about having their own children, so not only have you got them out of the system, you've got their future offspring out of the system. They are not going to paediatric cardiologists when there is a dizzy spell in the year 2025 saying 'I'm really worried my aunt dropped dead at the age of 35'... I think it's much better to push for gene testing on the basis of the avoidance of unnecessary lifelong follow up, the avoidance of worry and the strain it puts on paediatric cardiology and adult cardiology, with screening asymptomatic individuals until the age of 40... and the fact that this completely asymptomatic individual always thinks that they have got a problem. Even before they are being born their mother or father being told, it may be in the family but you don't have it, forget about it.'

(Cardiologist 3)

This passage is of key importance and ties in many of the rationing criteria I have discussed so far, it also connects the economic and risk rationing mechanisms. Most important is the reference to the family; the Cardiologist claims that the genetic test can serve to cut the patient off from their genetically predetermined risk, separating the pedigree into those at risk and those not, in the present and in the future. By firstly perceiving the family as a genetic whole, the clinicians can progressively prune down the family tree, associated through a pathogenic mutation, disposing of those who do not fit, ruling them out as not at risk, thus removing them from the system that the family members who cannot be ruled out are destined to continue in. I observed this ruling out once in the MDT. This news was given as a way of ensuring all services ruled out the patient:

'Geneticist 2: Have you discussed [name of patient], she Dr. X's [cardiologist who is not present] patient?



Nurse: No, Dr. X isn't here so we haven't discussed her have you got further information about [name of patient]?

Geneticist 2: She has been tested at [Lab] and she hasn't got the mutation, the family pathogenic gene.

Cardiologist: That means she can be discharged, no more checkups and no chance for her children or grandchildren having the condition.

Nurse: Well that's a nice end to the meeting.'

(MDT5)

This is the risk element of the rationalisation, if the goal is to reduce risk to that of the general population, then this is the most efficient way of 'knowing' this is achieved. One cannot say that the clinical domain actively achieves this, as the patient was not at any higher risk in the first place, they were at risk of being at risk. Although praxiological considerations of what SADS is and what it means to 'have' one of these conditions will be unpicked in Chapter 11, it is important here to introduce the multiple ways of understanding risk in relation to SADS. An individual in a family with a history of sudden death, but with no symptoms themselves can be at a level of risk of having the familial condition and of suffering a fatal arrhythmia, which can be the first and only presentation of the condition. As discussed, this level of risk is lower than if the individual did have symptoms or clinical presentations, via ECG reading for example, but is higher than the general population. The individual cannot be said to have the condition, nor can they definitively be ruled out, due to the risk object, sudden death. Cascade genetic testing, where a pathogenic mutation is found in the family still cannot definitively find that someone has the condition, as "phenotype is king" (Cardiologist 6), no phenotype no diagnosis. However, the level of risk in this situation would be assessed as higher than an individual with a family history that had not undergone genetic testing but lower than a

phenotype positive individual. A negative cascade screen does mean no condition (at least the known family condition), population level risk (1.8:100,000 (Papardakis et al, 2009). Genetic testing for these conditions are not diagnostic they are at most suggestive and are contingent upon the family considered as a whole. It is a risk-stratification device; it enables the allocation of differing levels of risk, risk of suffering a sudden death or risk of having the condition in the first place.

The economic benefit of ruling out in this way is twofold. The direct economic benefit for the NHS comes through the removal of patients, or potential patients from the 'system'. There is no need for checkups or systematic annual screening for the patient or their family from them on in the family tree, they need no expensive clinical/pharmaceutical interventions. However, biopolitical rationing calculations are also used to justify this method of genetic testing. In a recent service review Mark Anderson (2014) presented cost effectiveness data of cardiac genetic testing, presenting an economic rationale of the technology over the previous 12 months, in which he gave two scenarios. The first was presented as pre-genetic testing, whereby the cost of systematic screening of first-degree relatives of a sudden death victim was calculated at around £1300 per year. The second scenario was post genetic testing, using the data from the previous 12 months he was able to present how cascade screening would remove 50% of a family from the clinical system saving the NHS trust around £6000, simply by ruling family members out. When discussing the economic implications of cardiac screening and the use of the molecular autopsy, another geneticist was able to rationalise the technologies use based upon epidemiological and biopolitical rationalisations:

'...we did a health economics review of how much does the average 22 year old cost New Zealand to bring up as opposed to the tax revenue they lost by losing that person so young, so you took the average age of the population... It was going down then to government and saying you are losing in tax revenue x million

because people are dying young, but if we had a screening programme costing a tenth of that over the long term you would save this accumulative millions... the business plan convinces the pen shakers in the government.'

(Clinical Geneticist 4)

The economic rationing thus far has drawn upon clinical day-to-day rationing decisions. I have shown that these decisions are entrenched at the intersection between risk and resources. There is a constant balance to appraise risk of sudden death at the same time as having to ration scarce resources and ensure the maintenance of these resources through a justification of the service (for example testing those with a greater probability of yielding a positive result). By asserting 'all categories have wheels', Prior (2001) identified how risk assessment criteria are flexibly interpreted. In the case of cardiac genetic testing risk assessment decisions are contingent upon resource availability. Rationing calculations thus serve to maximise efficiency, and by efficiency I am referring to the greatest reduction of risk for the lowest price, ruling out as many individuals as possible. This extends Hughes and Griffiths (1997) thesis of '*Ruling in and Ruling out*'. By utilising Pinch's et al. (1992) weak programme of clinical budgeting in relation to rationing decisions, I can show, as Prior (2001) was able to, that categories indeed have wheels, i.e. ruling in and ruling out decisions are not static. They are made relative to the individual patient, to the family, to the context in which they are made and in relation to the political and economic sphere in which they are made. The final point I would like to make is in relation to the last quote given, this implicates much broader political considerations into the rationing framework. I have given the Welsh example of commissioning cardiac genetic testing, and have shown that it is not enough for a technology to be clinically effective for it to be commissioned. In a neoliberal commissioning environment there is competition for scarce resources, spending on each new treatment or technology needs to be justified in terms of both clinical and economic efficiency. Clinicians need to be bureaucrats, they need to audit

their services and ensure cost effectiveness and be able to convince commissioners to purchase the service. There needs to be a much broader conception of cost effectiveness and rationing decisions in the clinical setting to encompass this, extending clinician autonomy to include economic decisions. Specialist service provisions are not constrained by the limitations of the NHS, in a re-imagining of the structure of clinical services the next Chapter will engage with how clinicians as invested, autonomous communities, are able to extend and supplement their services by other means, NHS budgeting and commissioning no longer holds water as the limitations of service provision.

## **Chapter 6: Experimental Misconception: Mutuality of Research and the Clinic in Clinical Genetics**

A growing body of research suggests the divide between medical research and the clinic is becoming less pronounced (Timmermans and McKay, 2009a; Timmermans, 2010; Will, 2011; Hallowell et al 2009). Indeed this is explicitly advocated in UK policy in relation to the conduct of medical research. Will (2011) summarises this development, explaining that the policy environment advocates a mutually advantageous relationship between the health service and commercial biomedical research entities, showing a common focus on best possible patient care. Indeed much of the previous research in this area has focussed on the care-giving aspects of medical research suggesting that the research environment often offers patients a higher degree of care than would be available to them than would otherwise be provided within their respected health care environment (Timmermans and McKay, 2009a; Will, 2011; Fisher, 2015).

This becomes more pronounced when considering environments in which economic constraints result in limited access to health care resources, such as low-income populations. Both Petryna (2007; 2009) and Kelly et al (2010) report the therapeutic benefit offered by big-pharmaceutical companies for participation in randomised control trials by low income populations. Kelly et al (2010) go as far as to say that this type of research has been institutionalised within the Gambian health care system, and is recognised as an important health care resource. Equally, Hallowell et al (2010) reports that a major factor for patients in the UK deciding to enrol in a clinical trial is the potential therapeutic benefit which may arise as a consequence of participation. Bioethicists have expressed concern over these types of relationships between researchers and clinical populations, viewing them as potentially problematic due to the risk of an exploitative relationship on behalf of for profit organisations (Ballantyne, 2010). Concern has also

been highlighted by bioethicists in respect of where the line between research and the clinic become blurred; it has been suggested that patients/participants may associate the research process with the care it provides which fosters misunderstanding as to the knowledge building agenda of researchers. This has been described as the 'therapeutic misconception' (Henderson, et al 2007). This assumption of increased clinical provision and therapeutic benefit to patients is not however limited to patients. It has been commonly reported that clinicians will enrol patients into clinical trials based upon the assumption of access to resources unavailable in the health service (Hallowell et al, 2009). Indeed Epstein (1993) reported that the only way to access anti-retroviral medications for the treatment of AIDS was through access to clinical trials (although access to these trials was less than equitable). Hedgecoe (2006) gives the interesting example of a clinician who claims to enrol patients in clinical trials as a means of accessing the control arm of the trial as this often exceeds the provision provided by the NHS. Petryna (2007) reports similar findings, suggesting that providing 'equivalent medication' was a technique used by big-pharmaceutical companies to circumvent the ethical mine field of the placebo group. This of course runs counter to the narrative that clinicians are incentivised, financially or where they are directly involved in the research, through the potential to further their own career (Fisher, 2008) which again develops a narrative of coercion and exploitation of participants.

What emerges is a dual relationship of exploitation and expectations on behalf of the researcher, with clinicians and patients coming to this process with different agendas and expectations. Thus instead of simply presenting the therapeutic misconception it may also be helpful to equally emphasise the 'experimental misconception', in which the medical research industry perceive clinical trials and other research initiatives to primarily yield generalizable knowledge. In contrast, evidence from researchers studying the conduct of medical research and clinical trials consistently report the therapeutic agendas of clinical

researchers and research nurses (Timmermans, 2011; Will, 2011; Easter et al 2006) as well as patients (Hallowell et al, 2010).

This chapter will primarily discuss the experimental misconception, focussing on how clinicians and researchers mobilise clinical research as a means for improving clinical provision. In doing so I will extend the current corpus of research in the area in which clinical research is seen as an immediate source of therapeutic benefit (Hedgecoe, 2006; Timmermans and McKay, 2009a). Instead I will argue (inverting Latimer's et al. (2006) argument) that the organisation of clinical research can serve as a way to shape the clinical space in which the technology or test will ultimately be applied.

## 6.1 Clinical Research in Cardiac Genetics

The distinction between research and the clinic has been presented as particularly blurred in clinical genetics, both for patients (Parker et al, 2004) and for health care professionals (Miller et al, 2008). Clinical genetic testing can still be considered an emerging biomedical practice (Fox, 1959), as such, research is closely intertwined with clinical practice. This is visible within the gene discovery agenda of the 100,000 Genomes Project (Genomics England, 2015). Targeting rare disease groups, this agenda relies upon clinical partnerships (GeCIP's) to aid in the recruitment of existing patients from the clinical setting with the aim of better understanding the genetic nature of rare conditions. A key mantra of the 100,000 genomes project is to encourage collaboration with the NHS, creating a joined-up approach between Genomics England and the NHS. A key aspect of this is the emphasis of the project on 'patient benefit' (Genomics England, 2015a, p. 15). In a sense, this is a way in which the project attempts to overcome the epistemic problems associated with weighing advancing medical knowledge against the direct benefit to individual patients (Timmermans, 2010). The direct patient benefit in this project comes in the form of a 'clinically useful' report which is fed back to clinicians for each patient and contains the findings of the WGS and analysis. The 100,000 Genomes Project is in line with the UK policy agenda described by Will (2011), in that there is at least the presentation of a mutually advantageous relationship between research and the clinic. However, research and clinical mutuality in clinical genetics is not limited to large national projects such as the 100,000 Genomes Project. The genetics clinic has been positioned as a site of knowledge production (Latimer et al, 2006) in and of itself, over and above its identity as a space in which research is conducted or patients are enrolled. This is particularly acute in elite centres which, in keeping with Bosk (1979), are more willing to engage in novel interventions, therapies or tests. Many of these interventions can be considered N=1 experiments, particularly in the specialist clinical genetics setting in which patients may



be only one of a few with the particular phenotype, thus any genetic testing is experimental.

This chapter will discuss how clinicians in the field of cardiac genetics negotiate the mutuality of research and everyday clinical practice. In doing so I will extend notions of clinical autonomy beyond individual clinical decision making to encompass economic and organisational decisions which have effects upon the structure of their clinical practice. Unlike much of the other research in this area, the research/clinical interface which constitutes the focus of this chapter is not related to a clinical trial and thus can be considered of lower risk (Lidz, 2009), as such the consequences of therapeutic misconception are limited. Moreover, the interventions which constitute the research aspects of clinical practice that will be discussed are practically identical to those already experienced by the patient/participant, consisting of genetic testing. The primary difference in the interventions is at the analysis stage, where instead of analysing a predetermined, and accredited set of genes, the analysis is broadened to whole exome or genome sequencing looking to find novel mutations. Whilst this makes it difficult to make distinctions between research and NHS clinical practice the possibility for an adverse outcome is greatly reduced. In fact, health care workers were acutely aware of the indistinguishability between the clinical and research elements of contact they had with patients and had techniques for avoiding the therapeutic misconception to some degree. Much of this is by virtue of their experience as both clinical and research professionals.

In an NHS genetics clinic the process of conducting a genetic test is far more complex than conducting other routine biochemical tests and this is primarily due to the profound and extended impact genetic test results can yield, as well as the uncertainty inherent in genetic test results. Thus, the informed consent procedure is considered as one of the most important interactions a health care professional will have with a patient within their clinical trajectory. Across research sites, genetics counsellors undertook the consent

procedures for clinical genetic testing, offering genetic counselling as part of this process. However, where this ultimately led to recruitment into a research project for further testing, additional informed consent procedures would be undertaken to ensure the function of the research and the increased uncertainty associated with, for example a gene variant which is not reported in the literature, is emphasised. In such situations there is an explicit understanding by those involved in the research that patients or families may attribute significance to a research finding where the professionals may not and as such they attempt to manage this as best as possible:

‘In some cases I think people are just happy you can do anything because they may have thought, you know this terrible thing has happened and that’s the situation you find yourself in there’s nothing more that can be done so in some cases they are just thankful that you have tried. In other cases when you do find something that you’re not certain about again they do attach significance to it where you wouldn’t be attaching significance to it and you do end up having to explain again why you’re not regarding it as significant enough.’

(Genetics Counsellor 1)

It is not simply a case of research offering additional therapeutic benefits to the patients but it is that it is offering access to a different resource which may have benefits but also brings with it additional uncertainties as well as institutional differences.

## 6.2 Clinician-Scientist

The majority of the clinicians in this study were engaged in medical research to a greater or lesser extent, either as principle investigators or collaborators. In their examination of the professional dynamics of the clinician-scientist with regards to stem cell research, Wilson-Kovacs and Hauskeller (2012), place these professionals in the hinterland between the lab and the clinic which results in their de-legitimization. They advocate, however, for a reassessment of this categorisation placing the clinician-scientist as a key stakeholder in the translation of novel technologies into the clinic. The present study views the clinician-scientist in a somewhat different light, although reaches a similar conclusion; perhaps due to the status of the clinicians studied in both their clinical and research roles. In my research, many of the participants led their own large research projects and all of the clinicians interviewed were also at least at the consultant level in their NHS role and many were also Professors in their respective affiliated university. In contrast, Wilson-Kovacs and Hauskeller (2012) reported on far more junior clinician-scientists and thus the relationship that their respondents had with their fields of research and clinical area of practice had yet to be fully realised. Although I use the term clinician-scientist to discuss a different demographic to Wilson-Kovacs and Hauskeller (2012), the terminology will remain as it represents the duality of the roles of these particular professionals and the unique opportunities available to these professionals. Indeed, it is the status of the clinician-scientists that will be the focus of this chapter, as this distinctive position yields a high level of power over the shape of both the clinical and research space within the discipline of cardiac genetics. The following clinician is discussing this in relation to the ground breaking work he was involved in, in relation to cardiac ablation, which was a highly contentious and experimental procedure:

I: One of the advantages of being in my position as a clinician scientist, is that you can do things that you think you can get some benefits for patients relatively quickly, you can see where the need is and so on.

C: And did your dual identity as a scientist and a clinician help in the translation of this into sort of wider clinical practice beyond your own service?

I: definitely, I mean, and again exposure, or involvement in groups of cardiologists helps in that as well.'

(Cardiologist, 3)

Here he discusses how his position as a clinician-scientist, as Wilson-Kovacs and Hauskeller (2012) intimated, served as an abridgement, serving to smooth the translation between research and the clinic. As he was already embedded within the clinical cardiology culture he had the prerequisite networks and experience to understand how a technology is translated into clinical practice as well as the status to influence the uptake of this technology more broadly. In addition, his clinical practice enabled him to identify where the clinical need was and thus could develop his research agenda based on this need. Thus, the research agenda does not fit the generalizable knowledge making paradigm offered as part of the conflict by Fox (1959); instead it is positioned very practically as a way to fill a clinical need, with the production of knowledge as a secondary benefit.

The distinction of the clinician-scientist is somewhat arbitrary for high status clinicians, as research activity at the cutting edge of the discipline seems to be a requirement. Nonetheless there remains complex professional organisational negotiations which shape explanations of practice across clinical and research sites. This is further complicated where the research in which the clinician is involved is spatially organised in the same space as their NHS clinical practice (Will, 2001). This was the case for many of the

clinicians I was able to interview. This clinician explicitly discusses the distinction between his clinical and research practice in terms of the inter-professional relationships at stake:

'You are providing the leadership in the clinical setting and the other, in the setting of wider collaboration then it is collaboration; some areas or projects you will lead or co-lead and in others you will be part of the collaborative group. You therefore have a different responsibility or way of handling things in that setting and you're not dealing with the immediate priorities thrown at you by clinical management, patient requirements, patient needs, you are dealing with things that are maybe, thankfully not quite as life disturbing or life threatening. So it's purely career threatening and given that, that's a different sort of network of relationships with less clearly defined roles and expectations, it's harder to manage.'

(Cardiologist, 5)

The clear distinction here between the immediate priorities of the clinic compared to the research setting, in which inter-professional relationships gain importance and are positioned as more important for the clinician-scientist's career development is made explicit. This is something emphasised later in the interview in which the mutuality of both roles is identified:

'...for academic professional development you have to have successful research, successful research grants, successful manuscripts, successful students, successful supervision, successful examining etc. A lot of that is necessary... to begin with to provide the clinical service we provide here, so they are interrelated, they are not independent from each other, but there are separate demands. You know do I want to be a professor one day? Well, yes I'd like to be. But, if that's at the cost of not doing ones clinical job adequately then clearly not, because the reason I'm doing the research to begin with is to do something better for my patients and the

families I see. You know, we are still inaccurate and I'm waiting for those awful moments when you find out the decision you made was wrong, not to treat or to treat. Thankfully the moments so far have not been that way but there will be moments clearly that I will feel devastated with what I've done. The research, you know, there is always going to be a bit of glory seeking amongst people who do research and there will always be some selfishness about the academic environment because people are trying to get ahead. The academic work for me is extra and makes the job that much more interesting and exciting because what I do needs to be informed by that research and that you will make differences in the future from what your understanding from being on the cutting edge of that research. So the overriding priority is still the patient care and the research will be neglected to ensure patient care if required so we are all selfish individuals but hopefully ones not that selfish.'

(Cardiologist 5)

The conflict here is the same as that identified by Fox (1959), which is how do you weigh broad benefits which could result from research and which could also ultimately benefit the clinical patient, with the individual patient benefit within clinical care? The answer, although not clear cut, for this clinician is to prioritise the clinic on the basis that the reason he is involved in research in the first place is to benefit patients. He positions his research work as a means of making him and his field better at doing his clinical job. This is a concern in terms of the alignment of priorities in the clinical research setting, particularly where research participants are also clinical patients, which can lead to the therapeutic misconception on behalf of patients. However, by aligning priorities with patient care the argument is that the risk of this is greatly reduced. The mutuality of both professional identities is broadly defined in the above quote, on a personal – professional level. This clinician would not have the status to perform his clinical work without his

status as a leading authority in the field of ICC's, and without his specific clinical population he would not have the patient population appropriate for his research agenda. Status becomes incredibly important in this process. The status of this clinician and of the centre in which he is located is considered one of the best in the UK based upon their research track-record. Thus, when it comes to the allocation of resources he is able to demand a larger proportion than an equivalent service in a different health board based on status:

'That's the way our clinical genetics service is willing to do things, because that's our regional genetics service, they are serious about inherited cardiac disease, and that depends on individuals rather than necessarily you know NHS level commissioning decision making.'

(Cardiologist 5)

Professional status here equates directly to better service provision for the clinical population of the centre. Moreover, patients also have access to the potential therapeutic benefit of research in this setting which equates to more resources in the clinic as well as access to technologies not available via the NHS such as extended genetic test panels or WES.

### 6.3 Research Supplementing the Clinic

Although formal separations remain between resources allocated for research by academic institutions, third sector organisations, research councils or other sources of clinical research funding; where the research is undertaken within an existing clinical infrastructure, the distribution of resources and staff becomes somewhat blurred. This blurring of roles has been reported elsewhere (Easter et al, 2006), with researchers performing roles associated with health care beyond that necessary for the clinical research. This is commonly presented as a way in which the line between research and care is confused. It can however be considered as a way in which clinical services are supplemented by other resources. It is common in the field of cardiac genetics for clinical services to be supported by means beyond the realm of standard NHS commissioning. For example in 2008, the British Heart Foundation launched the Cardiac Genetic Nurse initiative to support patients and families with ICC's across England and Wales. They introduced nine new specialist nurse posts to existing ICC clinics for a period of three years. During this time these nurse became invaluable to the everyday organisation of these services, particularly in relation to the abridgement between cardiology and genetics services. I was able to interview three specialist nurses who were previously BHF cardiac genetics nurses. They described their role as the main point of contact for patients as well as performing the major organisational and administrative tasks of the ICC clinics, including the organisation of multi-disciplinary team meetings and of clinical appointments. Although this example does not concern the supplementation of the clinic with research resources, there is a similar reliance upon research clinicians and nurses who are employed within the clinical setting:



'[Charity] fund research fellows who... part of their remit is to receive clinical training in the inherited cardiac conditions clinic, so they also provide services in the inherited cardiac conditions clinic and that's part of their training as well.'

(Cardiologist 5)

The research fellows are organised in such a way as to support the functioning of the clinic, thus extra resources are available in this clinic over others in the country. Taken solely from the clinical perspective, utilising research resources to support clinical work can be seen as what Katz and Rosen (1991) describe as the principle of non-satiation; that even where there is an abundance of resources there will be a perceived scarcity.

Although, like any other NHS clinical setting there is no assumption of abundance, clinics are supported up to the amounts suggested in clinical guidelines by the NHS. This principle of non-satiation is an interesting concept to use here in that it opens up the possibility of the autonomy of clinicians in making decisions at the economic and organisational level of NHS commissioning and the acquisition and distribution of alternative sources of funding.

This is most pronounced within high status institutions with a good track-record of research funding. The clinics in these settings with world leading authorities at the helm utilise research funding to maximise their clinical potential. Research is used as an extension of the clinic. Within the ICC clinic this is the 'second stage' testing, which is only available to patients where the clinician has exhausted all other avenues of investigation, and/or the patient has a particularly interesting or rare phenotype. Although clinicians enrolling patients in research for therapeutic benefits has been reported by others (Hedgecoe, 2006), this is extended here to the point where research resources are sought with the primary purpose to benefit patients that would otherwise go undiagnosed. Thus, any therapeutic misconceptions are erased, as it is the principle investigator who runs the study with the intentions of providing clinically useful information for his/her patients.

This runs contrary to the discourse suggesting that research is used to supplement impoverished clinical services (Petryna, 2007; Timmermans and McKay, 2009a; Kelly et al 2010). It does however, garner support from Bosk (1979) who observes in his ethnography of a high status surgical service, that leading clinicians were more likely to engage in novel therapies and that more often than not these professionals were at the cutting edge of research in their area. This is evident in the field of cardiac genetics in which only the highest status institutions have access to 'second stage' testing. These centres are also national referral centres and thus have an element of control over who can access the second stage testing, a resource not available to all gene panel negative patients. Negotiation and access to second stage testing was presented at an MDT. During this meeting, the laboratory geneticist presented a case of a young woman with a rare phenotype presenting with severe arrhythmia on ECG. As the phenotype of the patient did not fit the standard clinical model associated the condition, the geneticist argued for an extended panel test, available at the lab they outsource genetic testing to. Due to the constraints of the service, meaning that the clinicians could only use pre-agreed gene panels, this request was rejected, based on the fact that this would cost an additional £750, which could not be justified. The laboratory then asked whether the phenotype was particularly severe, to which the geneticist said it was, emphasising how interesting the case was. This served as an entry requirement to second stage testing which was offered on a research basis. This example is particularly interesting in the way that the clinic in which the patient was being diagnosed and treated could not simply use the research findings clinically:

‘Once you put the patient into a research category, it becomes quite difficult to use that information, to feed back that information, the outcome of research, into the clinical setting. That is a legal difficulty<sup>14</sup>, a professional difficulty.’

(Clinical Geneticist 4)

In this case, the second stage testing found 2 mutations associated with the condition in the literature, but that were considered to be very rare, this makes it very difficult to hang a diagnosis on. Moreover, the reported findings were not in any official document, the geneticist accessed them through her professional connections with the laboratory and it would cost the clinic £200 to receive an official report, which would facilitate further investigations. The structure of this clinical service, means that the MDT is accountable for any expenditure of resources including the ordering of agreed upon genetic test panels. However, this unusual case falls outside of the boundaries of the commissioned service. Thus to confirm the gene mutation as pathogenic, via cascade screening of the family for the mutations, another pro forma to conduct a genetic test had to be completed as the initial research test was not ratified by the MDT and thus the £200 for the report would not be represented in the auditing of the service.

Clinical benefit is clearly the agenda for second stage genetic testing. However to be able to access this resource either through the acquisition of research funding or through accessing existing research resources, clinicians need to exercise autonomy beyond the limitations of the organisation of the NHS. Pre-existing networks, status and experience are necessary to be able to do this, as such this creates inequality of provision in which only the highest status clinicians at elite centres have access (or at least control access).

---

<sup>14</sup> Data gathered for research processes has to go through a process of anonymisation in keeping with the Data Protection Act 1998. Yet for the information to be clinically useful, the individual from which the data was taken needs to be identifiable. This issue has received considerable attention from Genomics England that has developed a process of anonymisation and de-anonymisation in the construction of clinically useful reports from the 100,000 Genomes Project (Genomics England, 2015). Such a process requires additional consent procedures (General Medical Counsel, 2009).

## 6.4 Mutually Beneficial Relationships

The previous section denotes how clinicians take advantage of research resources presenting little in the way of considerations of the research aspect of the resources they are accessing, this lends support to the experimental misconception in which the primary function of research funding is to benefit the patient. However, clinician-scientists are invested in both the clinical and research domain, this identity enables a rationalisation of the mutual benefit of clinical research, particularly when it is undertaken in the same clinical space. This clinician further develops a symmetrical narrative discussing this mutually beneficial relationship:

‘The NHS benefits to some extent because they are not necessarily paying for some of the clinical support in the clinics but it, there are benefits for each side and to some extent they cancel out, you know some aspects of the NHS will be paying for and other aspects [Charity] or the university would have supported. But it is important to us for our research as well, so we do see it as really a unified effort and you know where ever the money comes from its there to do the best for families and do the best for future research, so it works hand in hand. The trust values having us there because we are a nationally recognised centre that gives prestige but also clinical activity.’

(Cardiologist 5)

For this clinician, the clinical work is an important aspect of the research process. This is the primary benefit of the mutuality of research and the clinic for the clinician-scientist invested in the future translation of the technology or intervention with which the research is concerned. By placing the research process within the clinical infrastructure, not only is the validity and utility of the technology tested but also the ‘usefulness’ of it

(Hedgecoe, 2008), which relates to the more pragmatic issues of how the test or technology will fit in with existing practices. Clinical research, at least relating to the introduction or development of genetic technologies, can thus be seen as a clinical pilot, a way of developing a technology suitable for translation into the clinical setting. This model of research is advocated on the basis that the research infrastructure is more flexible than the NHS:

‘One of the challenging things is that in a diagnostic lab as you are aware you have got to set out what you are going to do and you’ve got to lock that down for a period of time. You can bring in a new version of something every 6 months or every year or whatever it is, but in a research setting if you run a sample and you look at it one way, the next day you can look at it in a different way, use a different piece of software until you find something you think is interesting. In a diagnostic setting you just cannot do that, you’ve got to be very strict in setting your criteria when you call a variant, make sure that its truly there, you’ve got to set various cut offs.’

(Geneticist 2)

This geneticist is talking about the development of bioinformatics pipelines designed to be used as part of the clinical genetic testing process. He discusses how the relative flexibility of the research infrastructure allows for the ironing out of kinks in the technology to suit his local clinical needs. This process of ‘developing confidence’ (Geneticist 2) in the test or technology, is cultural as well as practical serving as a way of getting clinicians and health care workers in the clinic used to using the technology as part of clinical practice (See Chapter 4 for a similar example). Hedgecoe (2004) similarly found that Roche offered HER2 testing to clinical reference centres as a way of changing the testing culture for breast cancer susceptibility genes as a way of increasing the market for the pharmacogenetic drug Herceptin.

## 6.5 Supplementary Misconception

However, developing confidence or pilot studies are by their very nature finite, in that the resources which support this translation (although not funded as translational research) are limited. Even where clinical research can show that the intervention or test is clinically useful it cannot help to establish how the development will be commissioned by the health service:

'Nobody has actually said where the cost will be covered in the future for inherited cardiac conditions.'

(Cardiologist, 5)

Indeed, there are reports in the literature of the impact of suddenly withdrawing research resources from a system which has become reliant upon them. Petryna (2007) reports on a clinical trial in Brazil in which a pharmaceutical company suddenly ended the study with no warning, which had the effect of halting the therapy of many participants with conditions that without the therapy would die within 4 years. Although the consequences for suddenly withdrawing resources would not have such a dramatic impact upon patients in the case of research resources supplementing the use of genetic testing for ICC's, the impact is felt in the organisation and practice of the clinic. Indeed this was the case when the initial funding for genetic testing for ICC's was abruptly stopped at the end of the Genetic Knowledge Parks initiative as discussed in Chapter 4. This earlier example offers an interesting dialogue between the experimental and therapeutic misconception: the clinical geneticist commented that while the genetics knowledge park was running the clinic had to send patient information along with the blood sample for genetic testing for the purposes of 'research and audit', but positions this as a means to accessing the technology. While this develops a relationship of mutual benefit for both the researchers

and the clinicians, the primary focus of the clinician is on the clinical benefit which is indicative of the therapeutic misconception. Conversely, the researchers with assumptions and agendas associated with gathering knowledge with regards to the genetic nature and extent of ICC's were subject to the experimental misconception. Clinicians primarily saw the genetic testing offered as a clinical service; thus clinicians, would only enrol patients that had no other therapeutic options within the commissioned NHS service.

Because of this misalignment between the clinical and research setting, particularly where these are spatially separated, there is a real risk of the therapeutic misconception on behalf of clinicians who enrol patients into studies with the agenda to obtain clinically useful information. The misconception is not of the technology or therapy offered; the genetic testing used as part of research studies has provided useful information for clinical patients. The misconceptions arise from a misunderstanding of the organisation of the research itself and thus clinician's expectations are not aligned with research practice. The primary misalignment is in relation to priority setting. For a test result to be clinically useful it needs to be provided relatively quickly, however when conducting genetic research, although effort is made to process and analyse the data efficiently, once the data are gathered there is less pressure to fast-track reporting. This is particularly the case when a large sample is needed for the data to be considered useful in the research domain. This causes tension between the clinical and research space where the clinicians expect to receive clinically useful results:

“This has been a traditional problem with research driven tests. When we first set up the MDT, because we had a lot of patients who had been told that their blood had been sent for testing at [specialist centre] in 2003 and we had no results available and then you spend often 12-18 months writing letters. Then you have to establish, whether the blood in 2003 had produced any meaningful test results. The vast majority of those people who have been down that route have ended up

being re-tested through the clinical service that we have available now. There are one or 2 that we have been able to get results for that did actually have mutations. That's been a bit slow.'

(Cardiologist, 6)

This brings into question how appropriate drawing on research for clinical benefit is for clinical services. The lead clinician who ran the study which is referred to in the above quote discusses precisely this point:

'The problem is research is not a diagnostic lab service, we get our DNA extracted at an NHS lab, but for research you batch your samples to do them at as low cost as possible over a three year period. That is just not suitable for clinical practice... we can't guarantee to have genetic testing available on tap to everybody in a timely way using a research service. Also, we are focussing not necessarily on what is immediately utilisable clinically but what may be utilisable in the future, so there are certain things that we accept clinically, should be done clinically. We won't guarantee providing genetic information, because we just can't give them what they need in a timely way and I don't think anybody thinks research projects should be funding clinical NHS activity and this is what we have suffered from in the past. A lot of all this work in cardiac genetics has gone on in research labs over the last 20-25 years and families have languished waiting for research results, which have taken years to eventually arrive. Sometimes that is very understandable because they are difficult genes to deal with, but sometimes it's just purely down to practical issues like the research fellow went back off into clinical work and therefore the data was untouched for a year or two. Things like that that are just not acceptable for managing patients clinically in the current era.'

(Cardiologist 5)



Taking the above two quotes together it is evident that what is, in the clinical setting, positioned as a problem with research oriented testing, is conversely presented as a misuse of research infrastructure by clinical services. As is shown by both quotes this has been a historical issue in the field of cardiac genetics in which clinical genetic testing was first made available for free via research by the Oxford Genetic Knowledge Park. A result of this issue is that services have come to rely upon this research infrastructure, and research has become embedded within clinical practice. However, this is not positioned as a problem of misuse of resources by clinical services, but instead as a problem with the NHS commissioning environment for genetic testing which is considered to allocate far too little to the conduct of genetic testing:

‘I think there is obviously a lot of effort from the current government to engage with the third sector and voluntary organisations to part deliver services or to support service delivery. I think when it comes to things like the genetic testing I think that is something that the NHS needs to provide because in the end I don’t think that [research funding] should be expected to be supporting that, and they’re not supporting that. Anything done research wise is for research and is supported by a research grant. I see it as a way of facilitating education, service development, training and research into inherited cardiac conditions, but there are certain aspects of service that will always need to be provided by the NHS.’

(Cardiologist 5)

In keeping with Will’s (2011) conclusion, this positions the rhetoric of mutuality between research and the clinic advocated by the UK government as a way to reduce health care expenditure. The wholesale effect of this is that if clinicians want to utilise a technology which is perceived to yield high value clinical information they have to rely upon research projects to supplement their practice. Thus, this supplementary relationship is supported by the NHS infrastructure. This becomes less a discussion of the therapeutic

misconception in that pragmatically clinicians will enrol patients into research projects in spite of the epistemic differences between research and the clinic based on the premise that the technology or test is not available clinically. Thus to subscribe to the therapeutic misconception is to agree with a deficit model understanding of the relationship between the clinic and research settings. Whereas the above quotes and the embeddedness of the clinician-scientist within the field of cardiac genetics would suggest that this is not the case, clinicians are well informed of the clinical limitations of relying upon research resources for clinical practice. However, the NHS commissioning environment for genetic testing means that clinical services do not have access to the cutting edge technologies that these clinician-scientists have experience using. As a result of this perceived scarcity, clinicians utilise research as a way of accessing technologies or resources that they agree should be provided by the NHS.

This does not negate the possibility of mutuality between research and the clinic, particularly when considering clinical research in the field of genetics as I have been here. Clinical research, is an effective tool for understanding how a technology or a therapy will translate to the setting in which it is envisaged to inhabit in the future i.e. the NHS clinic. It enables clinicians to iron out the kinks in a process of developing confidence, as well as developing knowledge in relation to the effectiveness of the intervention. For example studies utilising Next Generation Sequencing Technologies such as WES in an attempt to identify novel variants associated with particular phenotypes (GWAS), would not only develop generalizable knowledge in relation to the phenotype or the function of the particular area of the exome, but would also develop clinical confidence in the technology and develop a pipeline in which this technology can be used clinically. This is the way that genetic testing has developed in the field of cardiac genetics, which has traditionally been an early clinical adopter of new technologies. Establishing the way in which a technology or test will fit into existing clinical practices is mutually beneficial to both research and the clinic.

It is helpful here to take a step back and ask why clinicians are drawing on research resources instead of providing a clinical service in line with the limitations of that which is commissioned by the NHS. A major factor in these instances is that, as Will (2011) suggests, the NHS supports a mutuality between research and the clinic, and clinical cardiac genetics has a long tradition of engaging with research. However, an important issue persists following the completion of a clinical research project or indeed a pharmaceutical trial, which is that when the project ends the intervention is removed from the clinical arsenal. This is commonly presented as an ethical concern aimed at the researchers (See Petryna, 2007, 2009). However, more in keeping with Timmermans and McKay (2009b), I would argue that research offers clinicians and their patients sporadic access to a resource they would not otherwise be able to access. When considering this in relation to clinical genetics research the problems begins to emerge at the NHS commissioning level. Clinical research develops generalizable knowledge, access to a clinically useful technology, and most importantly develops a space in which the technology can fit in clinical practice. The one thing that clinical research does not do, is say how the technology will get commissioned, it does not guarantee the political translation of the technology. While clinicians in the field are indifferent to where resources come from, traditionally splitting responsibility for footing the bill for genetic testing between cardiology and genetics services, there is an ongoing concern associated with getting new technologies commissioned into clinical practice. This problem has persisted since the completion of the Human Genome Project, with the Genetics Knowledge Parks and governmental initiatives which developed from this helping to ease the issue. It has re-emerged as an issue with regards to the 100,000 Genomes Project, with the aim to translate high throughput genetic technologies into the clinical setting. When asked whether the 100,000 Genomes Project would translate to clinical practice a cardiologist responded:

‘Possibly it depends on if it actually ushers in cheaper genomic sequencing, and have that as normal practice. But again this is still going to be based on an additional £100 million with some additional research support from the MRC and others, and from Wellcome trust so that needs to be replicated in the NHS longer term. That means sustained resources, because it’s all well and good doing 100,000 people but if it is going to be meaningful in the future it has got to extend to a larger population than that, and that’s obviously taking things forward in a different way. Whole genome sequencing at the time of diagnosis? At Birth? When? And at what cost and at what implications financially, ethically, psychologically, socially, so I think that still needs to be worked out.’

(Cardiologist 5)

While a lot of work has been done by clinicians and researchers in the field of cardiac genetics to encourage the development of genetic technologies as well as ironing out kinks in the technology to enable it to slot smoothly into clinical practice, little work is done to ensure the continued funding of the technology clinicians have become reliant upon. It is often the case that when a technology emerges within clinical practice rationing negotiations have re-shaped the technology into a sub-par iteration of that used within research. Although clinicians of high status are heavily involved in the commissioning of services and the allocation of different funding pots, much of this happens in the period following the research.

Although I am reporting here on a relatively affluent health care system and upon high status institutions within such a system, the way in which research is utilised as a mode of health care delivery echoes the reliance upon clinical trials by more limited health care systems reported by Petryna (2007; 2009), Kelly et al. (2010) and Timmermans and McKay (2009a), in which research resources have become institutionalised within the diagnostic process. The primary difference in the case of cardiac genetics compared to

these other studies is that rather than drawing upon research to provide an elementary standard of care (Petryna, 2007, 2009; Kelly et al 2010) or to reduce inequalities in the provision of health care (Timmermans and McKay, 2009a), this study, more in line with Epstein (1993), argues that utilising research in this way increases inequalities in health care provision in that many of the studies are only accessible in high status clinics.

Moreover, the studies are not accessed to provide a minimal standard of treatment but are accessed based upon the lack of satisfaction with the clinically available technologies, which is garnered by the clinician's expertise in the field, knowing about and indeed developing the cutting edge technologies themselves.

Although the 'Experimental Misconception' is something of a straw man, it helps in taking a symmetrical approach to the interactions between research and the clinic. Instead of simply blaming research or 'big pharma' in the case of pharmaceutical trials, it helps to see the use of research for the purposes of clinical diagnosis, treatment or care as a rational decision by clinicians. In doing this, clinical autonomy is extended to more broad economic and service level decisions, in that research and other sources of funding can be utilised as a way to supplement clinical services in which resources are limited. This is done, not only to benefit the patient enrolled in the study but the service more broadly. Clinicians have to be fund raisers and resource managers in addition to providers of clinical care. They weigh the costs and benefits associated with research resources and thus no therapeutic misconception occurs on behalf of the clinician.

Finally, practically there is no conflict between research and the clinic in the field of cardiac genetics since it is in the best interests of the clinicians to extend the knowledge and diagnostic capabilities in relation to their discipline. Thus, instead of remaining a separate entity to clinical care, research can be considered an extension of it; much of the research as it is developed by active clinicians, is based upon clinical need and research enrolment is utilised when a patient has reached the limits of the clinical service. Instead,

the misconception occurs at the commissioning level when successful research fails to be implemented into clinical practice because clinicians struggle to get the funding.

## **Chapter 7: Next Generation Sequencing in Clinical Practice: The Translation and Interpretation of Genomic Data in the Diagnostic Lab and the Clinic**

The preceding chapters in this part served to outline the political and economic space in which genetic testing for ICC's is translated. As such I aimed to present how the this technology is heterogeneously imagined and employed in practice in the research and clinical space based upon the situated context in which it is experienced and translated. Clinicians are presented as autonomous actors/groups beyond individual patient decision making, extending notions of autonomy to the relations the clinician has with the broader political and economic health system. The overarching theme of part 1 thus far is of a pragmatic situated flexibility, in which clinical teams negotiate the limits of their services and jurisdictions as well as the standards and practices of genetic technologies as a way of translating this technology within their existing clinical services. This is positioned as a process of compromise, negotiation and adaptation, serving to extend the limits of clinical boundaries to encompass the use and acquisition of resources. This chapter will continue this narrative of situated reflexive standardization (Timmermans, 2015), however instead of focusing on the manipulation of the political and economic space in which genetic testing is implemented, this chapter will examine how the genetic technologies and the increasing data produced are locally co-constructed in the clinic and the diagnostic laboratory.

This chapter extends previous research which examines the clinical use of genetic testing (Latimer, 2013) and more recently Next Generation Sequencing (Timmermans, 2015) in that I specifically examine accounts of how the increased quantity of genomic and genetic data are negotiated in the NHS laboratory and clinic in the field of Inherited Cardiac Conditions (ICC's). I will also examine the interface and sharing of information between the laboratory and the clinic focussing upon how these professionals share situated

notions of confidence in data that are not consistent with defined practical standards. In doing so I will put into question the 'trust in numbers' hypothesis put forward by Theodore Porter (1995), instead asserting that big genomic data sets are viewed by clinicians and laboratory scientists as in a permanent state of acceptable contingency. By taking the perspective of those who contextualise, translate and interpret genomic data sets in practice in the clinic and the lab, I argue that clinicians and laboratory scientists are not 'data-dopes' (adapted from MacKenzie and Spears (2012) concept '*model-dopes*', which is a direct variant of Garfinkel's (1967) '*cultural-dopes*'). I will show they have an awareness of the effect increasingly large datasets have on their local practice and their profession as a whole, and that they do not naively accept big data outputs as wholly objective, or indeed useful. Through this I will show how clinicians and laboratory geneticists perform 'reflexive standardisation' (Timmermans, 2015) based on the perceived discrepancies between the technology (I include genomic data sets within this rubric) and clinical utility. In examining these issues this chapter will consist of two sections. The first will discuss how developments in genomic science and the use of big data have shaped clinicians and laboratory scientists practice in the NHS. The second section will discuss how these same clinicians and scientists mobilise and manipulate technologies as situated to their local practices and needs.



## 7.1 Big Genomic Data in the NHS

### *Genomic Data in the NHS*

The benefits of Whole Genome Sequencing (WGS) for research purposes in the field of rare diseases have been made clear, the primary benefit is that it enables the identification of novel gene mutations associated with rare diseases (Genomics England, 2015b). This has been the lynch pin of the rare disease mission of the 100,000 Genomes Project, positioned as 'Gene Discovery' (Genomics England, 2015a). Gene Discovery has been rationalised by Genomics England as a way of assisting in the interpretation of variants of uncertain significance (VUS), thus they present a reduction in uncertainty as a product of an increased quantity of data, committing to gather data from 50,000 people with rare diseases and their families. This prioritisation of quantity as a means of alleviating uncertainty has come to represent objectivity in modern times (Porter, 1995; Hacking, 1990). This subscribes to the common big data narrative in which 'Raw data' are a source of exploration and discovery, as an untapped, objective resource. In genomic science the larger the data set the more representative it is seen to be. An example of this is seen in the way researchers justify their findings or indeed criticise others. Elijah Behr et al. (2015) used a big data approach to overpower a smaller research study (Hu, et al 2014) which claimed an association with mutations on the Sodium channel gene *SCN10A* and the rare cardiac channelopathy Brugada Syndrome. Behr and his colleagues main area of contention with this study was their small sample of 200 matched controls<sup>15</sup>. By conducting their own larger study which used the UK10K project database as matched

---

<sup>15</sup> Frequency/absence of mutations in the general population, through the use of matched controls, is 1 of 7 criteria for attributing significance to a variation in a gene, promoting it from the category of variant to mutation. The other criteria are:

- Reports in the literature;
- Co-segregation in (preferably) trios;
- Conservation (of the amino acid across species);
- Functional domains (does the function of the amino acid reflect the phenotype);
- Presence in unrelated individuals with the phenotype;
- And, Functional studies.

controls, Behr et al. (2015) were able to assert authority over the concerned claim, refuting Hu's research. The UK10K database is considered quantitatively superior to Hu's control in 2 ways; firstly it is a database of genome or exome sequences, whereas Hu's control was of the single gene *SCN10A* and secondly the database consists of over 7000 individuals' exome or genome sequence data to control against (The UK10K Consortium, 2015). The sheer weight of data was mobilised to increase the legitimacy of Behr's argument:

'Our data suggest that rare variation in *SCN10A*, particularly in *SCN5A* mutation negative cases, is unlikely to cause BrS. This contrasts markedly with a recent paper by Hu et al. which identified *SCN10A* mutations in 16.7% of 150 BrS probands... This difference in yield cannot be explained from a technical perspective as conventional Sanger sequencing was undertaken in both studies. Of note, Hu et al studied only 200 ethnically matched controls without finding any missense rare variants. This is unsurprising as ESP and UK10K data both show that there are plenty of rare variants in controls but larger numbers are required to detect them reliably... Thus our 'enriched' cohort and more stringent 'mutation' definition are more likely to be representative of the yield of novel rare *SCN10A* variants in BrS.'

(Behr et al 2015, p. 16-17)

This ultimately resulted in mutations in *SCN10A* to be considered as of unknown significance by the research and clinical community in line with Behr's et al. (2015) findings (Conversation with cardiologist)<sup>16</sup>.

While in genetic research papers, sample/dataset size is correlated with certainty<sup>17</sup>, in the health service genomic data are used very differently, owing to a different functional

---

<sup>16</sup> This represents a shift in genomics research in which only those with adequate resources and connections can now produce valid scientific claims, creating class systems located around centres of excellence.

priority. Clinicians contest that newer technologies and larger gene panels actually increase uncertainty, as opposed to the decrease in uncertainty promised by research:

‘You have to be careful... the more genes you have the more uncertain you are.’

(Clinical Geneticist 2)

In the clinical setting size does not equal certainty. It is important to note here that before complex NGS (next generation sequencing) testing, where services were only testing at most a few genes per condition, clinicians were not more certain. However, clinicians were more certain of the validity of the gene mutations they did test for, during this time there were far more negative results, which does not preclude the possibility of a pathogenic genetic mutation. This is a distinction not in the scale of uncertainty but the type of uncertainty. NGS has heralded uncertainty associated with the validity of gene mutations found, where as pre-NGS testing was dominated by uncertainty associated with the ability of a test to capture gene mutations in the first place.

Negative genetic test results are welcomed in the clinical setting in particular circumstances, this is explained as the main difference between the use of genomics in research and the NHS. In the research, setting the introduction of NGS technologies has had dramatic effects in terms of gene discovery for rare conditions as a Clinical Geneticist with a research interest described:

‘The biggest change for us... has been this adoption of next generation sequencing.

From a research side of things one of the things we have been doing is trying to identify new genes that cause rare diseases... We have had a lot of experience at

---

<sup>17</sup> This is not to say that in the researchers naively analyse large genomic data sets as objective fields of ‘raw’ data which can be unreflexively mined. But it is to say that the strength of a research paper is increasingly measured by the size of the sample or data set drawn from. As this research has not directly observed or conducted interviews in relation to the negotiation of big genomic data-bases within research projects, I cannot make any claims beyond the way in which these data are mobilised as a sign of authority.

doing that and had a lot of success in identifying the genetic basis of a whole range of diseases.'

(Clinical Geneticist 2)

Where as in the clinic there is:

'A huge shift in emphasis, in science they look for the most variance and this is exciting, where as in the clinical setting no variance is a good thing, it means the patient does not possess the pathogenic variant.'

(Laboratory Geneticist, Laboratory Observations).

This Geneticist is referring to the 'Good-going' (MDT3, See Chapter 5) gene mutations, which refers to the gene mutations that are responsible for a large proportion of the conditions. If the patient is not found to have gene mutations within these genes the result is positive. This outlook is particularly useful when considering the testing of phenotype negative individuals. These may be family members who have experienced a sudden death (which is the most serious consequence of ICC's), or these may be family members of gene positive patients, in which case a negative genetic test can rule out a patient for further interventions as they 'do not possess the family gene'(Clinical Geneticist, 3). Thus genomic data, as is used in research, is not that useful for the health service for the majority of referrals, which are the 'Barn-door' (MDT 3, see Chapter 5) patients with obvious phenotypes, who are found to have the 'good-going' mutations. These cases have become routinised, and it is more clinically useful and efficient to use traditional Sanger sequencing techniques focusing on a specific gene or genes. The clinic and the laboratory have a high level of certainty that these mutations cause the phenotype - these are the black and white cases. Where NGS does become useful is in the grey cases those with complex phenotypes who do not possess the most common gene mutations.

*How Genomic Data has Shaped Genetics in the NHS*

Contrary to the significant shifts in emphasis between Genomic research and the clinical genetics in the NHS, Big Genomic science has not only shaped the practices of NHS genetics services but also the way in which clinicians and scientists view their profession and future developments in the field. This extends debates instigated by Steve Woolgar (1990) in that genomic data sets and NGS technology attempt to denote its prescribed uses and users. The first way in which genomic data sets configure their users is by denoting who the users are, the format of the data they access as well as how they use the data. For example data outputs from the 100,000 Genomes Project will only be made available through Genomics England secure server and permitted users (members of healthcare or research organisations) have to agree to data access agreements (Genomics England, 2015a). 'Raw data' cannot be exported from this database so users are restricted to the format prescribed by Genomics England. This is equally the case for the reference genome which was produced at the end of the Human Genome Project. As such for a researcher or a clinician to compare their data to that held within this database they must format their data in the same way<sup>18</sup>. For the research community legitimacy hinges on validation through large whole genome control samples as shown earlier. This has been extended to health service genetics who are no longer solely reliant on reports in the literature as a way of validating uncertain findings:

'We look at population cohorts who have had whole genome or whole exome screening and we use them very much to try and determine whether a variant is pathogenic or not. So if you have found it at a high frequency you can have more confidence that it is not a pathogenic mutation and we use that information in our interpretations.'

(Laboratory Geneticist).

---

<sup>18</sup> The model for representing genome assemblies currently advocated by the Genome Reference Consortium which governs the reference genome is GRCh38. This format has been adopted across the world as to be compatible with the reference genome.

This kind of work has emigrated from the research community and is becoming increasingly important in the clinical diagnosis of ICC's, in which much of the research associated with variants are highly contestable (See SCN10A example). In many respects, genomic datasets define how clinicians and NHS laboratories assign validity to a mutation; the image of objectivity (Daston and Galison, 1992) has been engineered in genetic practice to be represented by validation through quantity of data outweighing the value of the corpus of scientific research in the area. Although clinical geneticists and cardiologists in the field of ICC's do not access genomic data sets directly, the ethic of validity based upon genomic population controls penetrates the value that they attribute to variants. A Cardiologist discussing this referred to the value he attributes to a generally accepted association, this was the association between mutations on *SCN5A* and Brugada syndrome:

‘...for Brugada syndrome it [genetic testing] is totally unhelpful, the original study [(Chen et al 1998)] was not even controlled properly... the guidelines say it might be helpful, but not in my experience.’

(Cardiologist 2, [reconstruction based on notes].

Such an insight was gained by this clinician through embedded experience with genomic data and genomic research which utilise much larger data sets. Whereas prior to the prevalence of the use of genomic data in research the imperfections of Chen's et al. (1998) study were overlooked on the premise that an imperfect answer was better than no answer. Genomic data sets have enabled reflection upon the usefulness of previously commonly held beliefs. Thus, Genomic data sets have transformed the standards (Timmermans and Berg, 1997) of clinical genetics practice by redefining the standard of validity and certainty.

Data analysis and interpretation in the NHS laboratory is the most labour intensive task for the genetic scientist following the introduction of NGS, a by-product of the increased throughput and capacity offered by this technology is an exponential increase in the size of

the data output. With gene panels of up to 72 genes in the field of cardiac genetics, the output can be considered big data in its own respect, in that the yield is far more data than an individual can analyse without computer assistance. This has dramatically changed the workflow of the NHS genetics laboratory. Technicians and genetic scientists specialized in particular conditions and followed patients through the lab before the introduction of NGS, however with increasing throughput and automation of key processes in the laboratory; workers increasingly specialize in one stage of the process, adopting Fordist modes of production. The scale of data yielded from NGS necessitates this dramatic change in working practices in the laboratory setting to enable the management of the data.

Bioinformatics pipelines have been established to assist in this transition, filtering the data into a manageable quantity. Much of the bioinformatics software used in the clinical setting is outsourced to the technology provider. The software used at the laboratory I visited showed all the base pairs screened across the top of the screen, with all covered base pairs automatically highlighted by the program (there are often gaps in sequence data due to allelic dropout<sup>19</sup>). The program then focussed the gaze of the genetic scientist to the 'known' variants in the sequence, these being variations from the control sequence data as well as 'known' pathogenic variants' associated with the phenotype. The interpretation by the genetic scientist is only undertaken on the remaining highlighted sections, her analytic gaze is focussed by the software to specific base pairs, as much of the process as possible is externally automated. Genetic Scientists are limited in this respect as the processes of data manipulation which lead to the output that they receive is 'black-boxed'.

One of the greatest successes of the translation of NGS technology to the clinical setting is the acceptance of the inherent uncertainty associated with many of the findings.

Uncertainty is nothing new for clinical cardiac genetics, ICC's are complex; there are issues

---

<sup>19</sup> Allelic dropout describes the process by which copies of alleles fail to be amplified by the PCR (Polymerase Chain Reaction), this results in missing data in the readout (Wang et al, 2012).

of incomplete penetrance and there is a high proportion of mutations considered highly pathogenic in the general populations (See SCN5A). For one of the better understood cardiac genetic conditions, LQTS, the 5 most common genes associated with this condition are only thought to explain 68% of cases (Splawski et al, 2000). However, the advent of NGS in the clinic altered the narrative of uncertainty, in that it strengthening ideas of temporality of uncertainty. When using NGS in the clinic, finding a variant does not always equate to attributing validity there is much more liminality, in which patients are between diagnostic categories. Much of this is based on the implicit understanding that knowledge relating to the genetic nature of ICC's is far from complete. A narrative of development from certainty to uncertainty has been presented using two analogies, with pre-NGS testing compared to 'picking the low hanging fruit', or 'catching the fish at the surface'<sup>20</sup>. This represents the notion that before NGS, geneticists were only able to identify the 'good-going' gene mutations. However as these genes are found it becomes more difficult to explain the phenotypes of those without the good-going mutations. This often results in finding Variants of Uncertain Significance (VUS), the negotiation of which is a major problem when 'you throw your net wide looking at as many genes as possible' (Clinical Geneticist 1) as is done when using NGS:

'I always counsel about variants of unknown significance, and we still have patients who come back and say; 'Well I don't understand you have found the gene change so why can't you just do the blood test'. Then you have to cover it again and say: 'We did discuss this possibility in which we would find a variant that we weren't certain about and that we wouldn't offer to people who weren't affected. We don't know enough about the people with the condition who also have this spelling mistake and therefore we don't have enough proof that it's the cause.'

---

<sup>20</sup> These analogies were given by a representative from Genomics England on two occasions: in 2014 at the annual AICC meeting and in 2015 at the Cardiff International Cardiac Genetics Symposium. They were given as a way of presenting the rare disease gene identification agenda of the 100,000 genomes project, suggesting that the project could help identify the harder to reach mutations due to the use of whole genome sequencing.



(Genetic Counsellor 3)

Much of this kind of narrative rests on presumed limitations in the technology and assumes that finding quantitatively more patients with the mutation would increase certainty:

‘...as technology develops we can do more tests. So it’s making the family understand that they are not necessarily missing something but that it is a limitation of the technology.’

(Clinical Geneticist 1)

This is the first aspect of acceptable contingency, by this I mean the acceptance by clinicians and laboratory geneticists of the ‘promissory narrative’ (Stephens, 2013) provided by the genomic research community even though they understand the inherent uncertainties that the technology brings. Although genomic science does not constitute what Hedgecoe (2004: 515) terms a ‘promissory science’, in that it is well established and has had huge implications and applications in the research and clinical setting. This extends Merton’s (1942) notion of ‘organised skepticism’ in that I suggest no closure of this skepticism, instead suggesting a pragmatic acceptance of the inconsistencies and uncertainties of a technology following critical scrutiny. This does not reduce the ‘hope and hype’ (Marris, 2005. p.1) narrative, promising a greater understanding of the nature of genotype-phenotype correlations through the exploration of ever-expanding genomic databases. This was not a difficult ‘vision’ (Martin, 2001) to sell to clinicians in this field. The majority of the specialist geneticists in cardiac genetics are also research active, as discussed in Chapter 6.

The clinical acceptance of the rhetoric of temporary uncertainty is now embedded in clinical practice, whereby clinical geneticists and genetic counsellors present findings as contingent upon scientific developments and more data. The primary mechanism by

which this contingent uncertainty is performed, can be seen when a clinician is faced with a negative test result for a phenotype positive patient. In these cases, clinicians often wait for developments in the research setting to translate to the clinical setting and then re-tests the patient or family:

‘We have a number of families where we have tested them right from the outset with our half a gene, and then the 3 gene, then the 4, the 13 and now the 16 gene screen. We still haven’t found anything, it makes us think right ‘have we missed something because the technology before hasn’t allowed us to detect it and this technology has also missed the same thing’. We don’t like having those families and they would be the first ones that we go back to and say: ‘Oh by the way we have got a new test, fancy putting them on because we really want to find something’. We have got a family at the moment that has had a DCM [Dilated Cardiomyopathy] test, it’s been one of our families for years, and we have just found a lamin A mutation and that completely explains the phenotype.... We offer the best that we can at the time and keep up to date with making changes.’

(Laboratory Geneticist)

The emergent nature of our ability to interpret genetic findings also allows the possibility of ‘Red Herrings’ (Clinical Geneticist 1) in which new information sheds doubt upon the validity of a particular mutation and clinicians then have to re-categorise patients on this basis, certainty of findings is rarely presented by clinicians.

The narrative thus far has been of how the change to high-throughput genetic technologies such as NGS has shaped modern clinical genetic practice in the NHS. The big biological data revolution and the resultant bioinformatics emigration into the NHS laboratory has engineered the ‘correct’ (Levin, 2014) way to analyse genetic data as well as defining that which is valid for interpretation, and the form of the output produced by the Laboratory (Timmermans and Berg, 2003). This shift has also changed the material practices and

tempo of the NHS genetics laboratory, with automated systems running 24 hours a day and technicians managing the technology. Perhaps the greatest impact the shift to NGS has made on cardiac genetic clinical practice has been the enculturation of the idea that genomic data are not only vast but emergent, flexible and dynamic (Rose, 2013), which has had the effect of realigning notions of certainty. Although of course VUS's were around long before NGS they were far rarer in the clinical setting. The introduction of NGS and the potential of WGS has heralded the possibility of a deluge of mutations, this creates a problem of quantitatively more uncertainty as well as the problem shifting from having to negotiate whether the VUS is significant to having to negotiate which VUS is significant and being able to say why.

## 7.2 Contextualisation, Transformation and Manipulation of Genomic Data

### *Situated data for situated practice*

The previous section discussed the impact of developments in genomic technologies in the NHS clinical genetics setting. However presenting the relationship between the clinic and the technology in this way assumes that clinicians and laboratory scientists are uncritical consumers of the technology, it assumes they are 'data-dopes'<sup>21</sup>. The potential of the consumer of genetic technology to become a data-dope has been observed in previous research by Bourret et al. (2011), in which they reported on diagnostic tools used to identify genetic tumour signatures. These tools had been marketed as prognostic and predictive by their creators and utilised algorithms which provided results that the clinicians themselves could neither derive, confirm, nor validate independently, due to the lack of transparency as to the means by which the result is constructed. However, Bourret et al. (2011) reported strong oppositions to technologies which excluded clinical autonomy, to the extent that the FDA created a separate category to regulate such devices. This is not to reduce the impact of NGS in the NHS lab and the clinic, however the translation of research to the clinic cannot be represented as neutral or one sided where clinicians and scientists alike naively accept the data as objective. In fact, this process is a strongly negotiated one, underpinned by an understanding of genomic science and genomic datasets as mutable, dynamic and fallible and that clinicians and laboratory geneticists are able to mobilize the data beyond their pre-defined configurations. Clinicians and scientists are intrinsically aware that genomic data sets are both 'cooked' and 'noisy' (as opposed to raw and clean). This section will discuss the effect of this in the NHS clinic and laboratory. This is part of acceptable contingency, as suggested earlier

---

<sup>21</sup> This terminology is in-keeping with MacKenzie and Spears (2012) definition 'Model-dope' (p.7), which is itself a derivative of Garfinkel's (1967) 'Cultural-dope' (p. 68). Both use the 'dope' as a rhetorical device designed to create an other. I am not saying that 'data-dopes' exist and I have not observed any in practice, however by presenting the argument that big data influences clinical practice I am assuming the existence of 'data-dopes', which is an illusion I hope to soon shatter.

when clinical geneticists were shown to accept NGS in spite of the heightened uncertainty it yielded. This being for the most part owing to the acceptance of the ‘promissory narrative’ (Stephens, 2013) given by genomic science but also due to the perceived improvement in clinical utility that NGS yields. Utility in this respect is relative, based upon a definition from clinical chemistry, which describes a key aspect of utility as the extent to which the test (or technology) affects ‘health outcomes relative to the current best alternative’ (Bossuyt et al 2012, p. 1).

Drawing on Stefan Timmermans (2015) work on the negotiation of standards by clinicians in the clinical genetics setting, this section will discuss how clinicians and laboratory geneticists employ a process of ‘*reflexive standardization*’ (Timmermans, 2015, p. 79). Examining how clinicians and laboratory geneticists ground the standards, in this case being the standard ways of negotiating genomic datasets and technologies within their situated practice, creating what Francois Thoreau (Unpublished) calls ‘situated data’.

### *Situating the Data*

This argument is supported by a strong pedigree of previous research, much of which centres around the idea that local clinical experience outweighs scientific consensus when making clinical decisions. Bosk was an early proponent of this, stating:

‘in the case of discrepant opinions, arguments based on clinical expertise override those based on scientific evidence.’

(Bosk, 1979, p. 85)

Latimer et al. (2006) and her colleagues similarly found this in relation to the value attributed to negative genetic testing showing that local clinical experience with the patient outweighs the findings of a genetic test and the presence of the genetic condition is not discounted. Hedgecoe (2008) went as far as to show how when considering the usefulness of APOE4 testing in Alzheimer’s disease patients, clinicians would disregard

genetic findings in favour of clinical findings and experience. Although this has been discussed in MDT's, it is generally avoided by clinicians by focusing the technology only on what they see as clinically relevant prior to conducting the test. Although only certain clinicians who have a genetics lab within their NHS trust have the freedom to select which genes are analysed, ICC clinics across England and Wales have the autonomy to select which gene panel they use. This is firstly because there is a significant difference in the constitution of panels for individual and grouped conditions between laboratories, and secondly because each panel test within each centre is made up of different genes. This is most notable where a patient presents with a non-typical phenotype as was the case at an arrhythmia MDT I attended:

'Cardiologist: I think we should definitely look for Danon

Clinical Geneticist: The thing is LAMP2 is on the HCM panel. So we could look for others using this to cover more things like sarcomere and I don't think our funding stream would support just a DCM panel.

Paediatric Cardiologist. So we are looking at the extended HCM panel. Well she did initially present with increased LV mass so...'

(MDT8)

The patient in this case was a young girl presenting with Dilated Cardiomyopathy (DCM) a weakening and thinning of the heart muscle, however the clinicians suspected from her pedigree that she might have Danon disease, a rare disease presenting with either DCM or HCM. Guidelines dictate that when a patient presents with DCM they should receive targeted genetic testing (Ackerman et al, 2011), however targeted testing in the guidance does not cover LAMP2. Clinicians in this case asserted autonomy, not in their judgement over the validity of the test but of its ability to capture the nuances of the patient's

phenotype, thus increasing their chances, from their experienced perspective, of finding a clinically useful mutation.

In the laboratory, clinical needs and preferences are taken into account in the data filtering and analysis stage rather than at the point the test is undertaken. For every sample received for a cardiomyopathy panel or an arrhythmia panel test, the laboratory will run their entire panel and filter the findings so to only analyse the genes in the locations associated with the phenotype as given by the clinician:

‘In the New Year we will have a new panel and essentially we will run it on every patient that we are requested a cardiac genetic test on. We run all 72 genes but we only analyse those dependant on the phenotype, we categorise them into different conditions, long qt, hypertrophic cardiomyopathy... So it might be for ARVC that we screen 6 of the genes out of the 72, the data are there for the 72 but we only look at 6. That speeds up the analysis, it means we have got a single pipeline for the testing but in terms of generating the result, it means that it’s quicker and we are not looking at data that potentially isn’t informative and that would delay and actually maybe even complicate things. If however new phenotypic information comes to light we could always come back and look at that data.’

(Clinical Geneticist 2)

Much of this is cost related. It costs the lab the same amount to test for 6 genes as it does 72 by virtue of using the same technology and the same amount of reagent. The main variable in cost based on size of the panel is accumulated at the analysis stage. This is equally the case when clinical exome sequencing is undertaken:

‘I see a number of patients with rare conditions where we have got a good idea of what the potential genes could be but there is no testing available for those in a routine diagnostic lab anywhere. The only way really to integrate those is by using

an exome and we run the whole exome but we would only pick out certain genes that we were interested in looking at.'

(Clinical Geneticist 2)

This filtering process is thus a process of practicality. In the NHS setting, genetic testing is not undertaken on an exploratory basis – rather, genetic testing for ICC's is commissioned on the basis that around 50% of test results will be gene positive (Cardiologist 3).

However, this is also a sign of the culture of risk aversion in clinical genetics (Timmermans, 2015). Laboratories will not send out a report based on a mutation they are not sure about, in terms of association with the reported phenotype. It does not make sense for them to analyse a gene they would not report on. This is also a practical data management technique, as clinical laboratories simply do not have the time to analyse each base pair in a whole exome or even each variant. Calling this whole exome sequencing brings up interesting questions about the relationship between the technology and the analyst. The whole exome has been sequenced so the process has been technically achieved, however the data output in its 'raw' form is simply stored away, so an analyst may never see it. Pragmatically this process has its advantages in that if no pathogenic variants are found in the genes analysed then the scope of the investigation can be broadened without having to go through the technical process of taking a blood sample, extracting the DNA and re-sequencing other parts of the patients genome. The process of storing sequence information is both economic and efficient, particularly where there is uncertainty associated with where the mutation is likely to be. It also serves to alleviate the ethical problem of incidental findings in that this information is only assigned meaning following human interpretation (for a discussion of the ethical issues of disclosing WES results in the clinical setting see Hallowell, et al, 2015).

*Representational Uncertainty*



Data are further filtered by the bioinformatician who works with the geneticists in the lab. By having a bioinformatician as part of the laboratory team, 'pipelines' and software can be developed to represent the particular needs of both the laboratory and the population they serve, ensuring that the geneticists get locally appropriate data. This is valued by the particular centre I visited due to their past involvement in WGS, in which they were made aware of the not inconsequential variation in the genomes they sequenced compared to the large data sets such as the Reference Human Genome:

'When you map the whole genome and we have done 30 here, you find 5-10 X excess [variation in the normal population] more than what you would expect. We have found many class 5 variations ['known' to be pathogenic] for long QT syndrome and Brugada Syndrome. This is a lot more than you would expect to find in the general population which makes you question earlier assertions.'

(Clinical Geneticist 1)

This centre and many others had the perception that all genomes were more or less the same (over 99%). However, the validity of this claim is increasingly coming into question. The cause and resolution to this misunderstanding comes from genomic datasets. Because of the size of these datasets, deviations from the mean, become increasingly invisible – as the size of the dataset increases it is considered more representative of what a normal human genome should look like. However recent evidence suggests that even the genomes of monozygotic twins vary slightly, mostly through copy number variation (Bruder et al, 2008), and these changes can have significant consequences with reports of discordant monozygotic twins, where one suffers with a congenital heart defect. The result of this experience is the understanding that genomic datasets do not truly represent their local situation, thus an effort is made to situate the data themselves. This can be seen as a form of *reflexive standardisation* (Timmermans, 2015) as professionals in the clinic and the lab

are not simply rejecting the assumptions made by large international genomic datasets but manipulate these assumptions to better fit their experience and practice.

Because clinical genetics services in the UK tend to get local referrals, the genetic variance in their clinical population is far more constrained than an international genome database and this has great implications for the utility of testing for certain genetic mutations. A good example of this come from genetic testing for Cystic Fibrosis in British Pakistani populations:

‘We have a standard UK Cystic Fibrosis test but we have also designed one which is targeted for the Pakistani British population so it picks up all the mutations that arrive within that population, applying the British test is completely pointless, it doesn’t have the same pick up rate.’

(Clinical Geneticist, 2)

The most common Cystic Fibrosis mutation, *deltaF508*, is reported to be present in 74.1% of Cystic Fibrosis sufferers in the UK; however, it only represents 24.7% of British Pakistani Cystic Fibrosis sufferers (McCormick, et al 2002). The pickup rate of a Cystic Fibrosis panel would be very low for this minority population, which is a particularly large demographic for this geneticist. In this case, the genomic databases and population studies do not represent the local clinical population so the data are situated post-hoc to deal with this. Although the situation is perhaps less striking in cardiac genetics it none the less persists and has implications for both the mutations that are looked for and value attributed to certain genes reported in the literature. A laboratory geneticist discussing her cohorts noted how this is particularly tricky:

‘We get a lot of referrals from [location] and there is a specific mutation we have found in some [minority group] families, we don’t know whether they are related as well. Now we tend to get asked for the [minority] mutation, if they send us a

sample from [minority] families... Where we find that [mutation] we will contact the clinician and we'll say 'by the way we've found this', because they may not know that this is not common in the rest of our cohort.'<sup>22</sup>

(Laboratory Geneticist)

This centre is also an internationally renowned referral centre, receiving many referrals from New Zealand that causes a similar issue:

'We have got a couple of new Zealand families... who have got the same mutation that we've not found it in any of the UK families or any others in the world. Alongside that, there are other variants that you find in different populations as well. You usually end up classifying them as unlikely to be pathogenic but sometimes they are UV's (unknown variants). In Maori New Zealand people or black Africans, you would expect to find genetic variation or variants that you are not familiar with in Caucasians.... It does make it tricky to interpret because the cohorts of information that tend to be published are in Caucasian populations. We are not testing a lot of African people so it doesn't cause a big problem. But, if we were suddenly to have a collaboration with an African country or community we might need to think about what other data we would need to interpret those variants.'

(Laboratory Geneticist)

Although this issue of diversity in datasets is reducing over time as more genomes are sequenced across the world there remains an understanding at the clinical level that databases of genomic information are over populated by Caucasian samples.

It is through recognising this *representational uncertainty* within genomic databases in terms of both the racial demography and the ability of the databases to accurately capture

---

<sup>22</sup> This extract is heavily anonymised due to the stigma attached to co-sanguinity.

the genetic characteristics of their local populations that clinicians and scientists are able to reflexively attribute clinical value to some recognised variants over others. In the same vein this uncertainty offers clinicians the opportunity to attribute validity where scientific consensus would be at best uncertain, however officially this is far more difficult to achieve. Laboratory Geneticists are restricted in their reports in terms of the autonomy they have to attribute significance to variants that are not supported in the literature or are not recognised on OMIM (Online Mendelian Inheritance in Man) or HGMD (the Human Gene Mutation Data Base) (See, Timmermans, 2015 for a discussion on these databases). As a result, the Laboratory conveys their situated certainty in more subtle ways as to avoid any future comeuppance as a professional accountable group. This is only achievable through close collaboration with the clinic:

‘We wouldn’t necessarily report something because we think it might be doing something, everything is evidence based in terms of what our reports say. As much as we might think that a mutation... and I mean we sit there and think about a mutation because we are just not sure how to report it. There is one gene at the moment, Tropomyosin, we know just from our reading in terms of the function of the gene and how well conserved it is, we know that if we found a mutation in there it *is* going to be what has caused the phenotype, but there is not much reported out there. So in terms of evidence building we can’t hang it on anything. You can’t just say I think that’s what’s happening. The expectation of the clinician is that actually they may also think that it is pathogenic and they may also tell the patient that it’s highly likely to be pathogenic but we haven’t said that on our report and we can’t say that.’

(Laboratory Geneticist)

By not providing black and white answers to the clinician, which this geneticist claims they are no longer able to do, she is putting trust in the clinician to be able to interpret the

genetic test report in relation to the patient's phenotype, attributing validity or discrediting the findings on this basis. The clinician-lab relationship is incredibly important for the laboratory geneticist, she needs to trust that the clinician has the ability to expertly interpret her report and situate it as part of the differential diagnosis of the patient and their family. As such, the laboratory will only accept referrals from within the community of cardiac genetics, including clinical geneticists as well as some specialist cardiologists:

'We tend to phone and check with a cardiologist because... they are very confident people and you know they, in their eyes they have requested the most appropriate test for their patient, but they might not necessarily understand all of the ins' and outs of it and trying to get that message across is sometimes quite difficult.'

(Laboratory Geneticist)

The assumption that a certain level of expertise is required to negotiate genetic testing as opposed to other tests such as biochemistry permeates throughout the NHS genetics lab and clinic. The ability to interpret, manipulate and situate data is seen as a prerequisite entry requirement to the cardiac genetics professional community. This is precipitated by the understanding that genomic datasets and the standards of practice in relation to these datasets do not reflect their local clinical needs and are more reflective of the needs of the research setting. However uncertainty of the value of genomic data is not solely based upon the inability of these data to fully encompass the characteristics of their local population, and by this I mean both demographically as well as in terms of the characteristics associated with gene mutations (i.e. phenotypical heterogeneity).

### *Mechanical Uncertainty*

There is also an understanding that the technology itself is somewhat flawed in its ability to 'truly' represent the human genome. This second type of uncertainty can be referred to as *mechanical uncertainty* in that it is uncertainty based on a deep, technical

understanding of the technology used to the extent that the inaccuracies of the technology are known. For the laboratory geneticist this uncertainty is garnered through a familiarity with the processes of sequencing genes and whole genomes, they are also aware of the technical challenges of using the technology and the ways in which one would overcome such issues in a local environment. This reflects MacKenzie's (1990) uncertainty trough where those close to the production of the knowledge or technology have a high level of uncertainty in relation to its ability to perform the task it is designed to do, and to produce an objective image of that which it is designed to capture. *Mechanical uncertainty* serves as a response to Daston and Galison's (1992) *Mechanical Objectivity* (p.82). WGS and NGS as a whole marked a move in the biological sciences to become more 'true to nature' (Daston and Galison, 1992, p. 85), in that it is presented as a technology, that with very little human intervention can read and present an objective image of the human genome. However just like the human eye, this technology skips over some sections or focuses too heavily on others resulting in a subjective image of the human genome. NHS Laboratory geneticists see these issues and correct them as part of their everyday practice, they are green fingered and can get the technology to cover what they want through work-arounds and modifications:

'For NGS technology we know that it doesn't cover an entire gene or an entire region, there might be the odd base here and 2 bases there and 15 bases there that aren't covered and that is because of the way that the probes bind to the original DNA. For the genes that have the highest clinical utility, so where most of the mutations are found in people with a certain disease, we will Sanger sequence across those gaps to make sure we have got complete coverage of that gene or of that exon... We know what the coverage of our test is, we know it might not pick up huge duplications it might not pick up huge deletions, it might not be very sensitive in homo-polymer tracts, which is a tract of similar nucleotides all in a row because the probes don't like binding there, or they bond too strong and don't

dissociate when they should do. Over time and with experience you get to know more about the limitations of the test.'

(Laboratory Geneticist)

In this process of local 'co-construction' (Clarke and Fujimura, 1992, p. 7), the laboratory ensures that the technology used is fit to perform the task they designate. This is gained through a deep knowledge of the technology and its capabilities to perform the necessary tasks. Moreover, knowledge of what the test covers and what it does not, impacts the reports that are given to clinicians, mechanical uncertainties are not ignored they are instead embedded into the practices of the lab and minimised as much as possible. However, this does effect the labs interpretation of 'objective' datasets and the validity attributed to particular research findings. Because the NHS laboratory uses the same sequencing technology as the research setting they know the mechanical uncertainties associated with it, this mediates the certainty attributed to research findings and of control sequence data. For example the laboratory will further investigate areas of genes associated with conditions, which might not be fully covered by NGS because, in their experience, and based on a technical understanding of genomics they 'know' functionally that a mutation in this area could be responsible for the phenotype, even where it is not reported in the literature. This is not to say that NGS is not 'the right tool for the job' (Clarke and Fujimura, 1992) but instead pragmatically asserts it is the best tool for the job at their disposal at this time (Bossuyt, et al, 2012). By understanding the uncertainties, clinicians and laboratory geneticists can manipulate the technologies and data to reduce the uncertainties experienced in their local practice.

The foregoing demonstrates how data and practice mutually structure one another – both in terms of how technology and genomic data structures the way it is used in the clinical setting and how the users re-configure the technology and data to better fit their situated practices. The broader significance of these observations about the connection of data to

practice is what they highlight about the concept of 'clinical usefulness'. The overarching argument of this chapter is that genomic data only becomes clinically useful through a process of co-construction at a local level, through an interpretive employment of standards and a radical transformation of data.

Clinicians are acutely aware of the constitution of genomic databases, as a result of the regular enrolment of patients into clinical trials and WGS projects (See Chapter 6). As such, it is the clinician that construct who are counted, they are responsible for data acquisition. Although they are not involved in the technical process of counting, they are still aware that the data they use are not 'Raw', in that participants are pre-selected and thus not representative. Laboratory Geneticists are also acutely aware that the datasets are not 'Clean'. Due to an understanding of the technical issues associated with DNA extraction and sequencing, the signal-to-noise ratio is far too high, as is shown by the way in which the laboratory post-hoc cleans the data output.

The clinical use of NGS has instigated a relationship between big genomic data and clinical practice. However, genomic datasets are not used, they are worked with and worked on in relation to the needs and practices of the patients in a process of *reflexive standardization* (Timmermans, 2015). To this end, I argue that an implicit trust in the objectivity (Porter, 1995; Daston and Galison, 1992) of genomic data and sequencing technology, as embodied within large genome research collectives (Cambrosio et al, 2006) is a flawed representation in the therapeutic context. It is by seeing the data and technology as in a state of acceptable contingency that it becomes clinically useful. By perceiving the imperfections (substantive and local) inherent in the technology, practitioners in the clinic and the laboratory are able to re-construct and manipulate the technology to a point of clinical usefulness. This expands debates concerning the resistance to or usefulness of a genetic technology (Hedgecoe, 2008) in the clinical setting to asking questions of how



clinicians construct and re-construct technologies to fit their purpose, this will be extended to the medico-legal setting in Chapter 9.

With genomic data becoming more accessible and prominent in the clinical setting and beyond, it becomes increasingly important to discuss its use in practice beyond the research setting. This chapter shows how these datasets are considered both 'noisy' and 'cooked' by its users in the clinical setting. Understanding genomic data in this way precludes the possibility of 'data-mining' in that the data genome sequencers produce are not naturally occurring nor can they be considered 'raw'. Populations are purposely selected for inclusion in databases and the data are manipulated and reconfigured. The data are externally configured and locally reconfigured creating situated data appropriate for informing clinical decisions. It is important here to re-emphasise the place of genetic testing in the cardiac genetic clinical setting: in the vast majority of cases genetic testing is used to confirm a diagnosis made based upon clinical presentations, or to cascade screen families of a patient with a clinical phenotype. Genetic testing is rarely fully predictive in this setting, but instead makes up part of the clinical picture, the weight and value of a genetic mutation is assessed by the clinician based upon his/her experience and expertise, there is no formula, validity is attributed on an individual basis. This is important to note when discussing the use of genomic data outside of the clinic in the insurance industry for example (Van Hoyweghen, 2007). Viewing genomic data as objective and representative risks a reduction in the complexities associated with using these data in practice. In saying this 'data-dopes' become a real risk, the possibility arises that certain groups may use the data without the pre-requisite 'reflexive standardization' skills, without the skills to situate the data within their particular practice, which presents the very real risk of the inappropriate use of genomic data. These issues become more important in Part II, in which the usefulness of genetic technologies will be discussed beyond the clinical setting in the medico-legal setting of the coroner and pathologist.

## Part II: Medico-Legal Aspects of SADS

### Chapter 8: The Medico-Legal Usefulness of Genetics

The premise of the ‘usefulness’ (Hedgecoe, 2008) of genetic testing for ICC’s in the clinical setting has at stake issues of technical uncertainties associated with the technology as well as the suitability of the technology to serve an identified function (Clarke and Fujimura, 1992) in situated practice. In this chapter, I extend the scope of the usefulness of genetic testing beyond the boundaries of clinical genetics and medicine as a whole. Although this appears to support an understanding of a ‘*geneticization*’ (Lippman, 1991) or ‘*molecularization*’ (Rose, 2001) of science and society, serving to position the molecular as the regime of truth, this chapter will not advocate such strong conclusions. Instead, I will argue that while genetic information has increasingly become relevant in the medico-legal setting, its relevance is contingent upon the practices and constraints of the medico-legal death investigation.

The importance of scientific evidence to legal practice has been well documented (Jasanoff, 1995), as have the differences between science and law (Latour, 2004) in terms of their discourses norms, and values. The effect of this has been a critical understanding of the use of scientific evidence in legal practice by scholars (Lynch and Cole, 2005; Lynch and Jasanoff, 1998; Smith and Wynne, 1989; Jasanoff, 2006). Moreover, commentary suggests that legal practitioners mobilise scientific evidence in ways seen to be problematic (Priaux, Weinel and Goldsworthy, 2016), due to the limited ability of legal professionals to negotiate the contours of scientific evidence effectively, instead invoking common knowledge (Priaux and Weinel, 2013) or stereotypes as is seen in the determination of intellectual disability in the USA (Pifer, 2015).

In the Coroners' System of England and Wales medical evidence figures heavily in the establishment of the conclusion to the inquest, this is primarily through the instruction of pathologists to conduct post-mortems and act as an expert witness reporting their post-mortem findings in the coroner's court. This chapter will empirically examine how medical evidence is negotiated within the coroners' system specifically discussing how useful genetic knowledge is in this process when investigating potentially SADS related deaths and the construction of 'usefulness' in this process. I will first discuss the structure of the relationship between the coroner and the medical evidence they rely heavily upon.

## 8.1 The Place of Medical Evidence in Coronial Practice

The role of expert evidence in the coroner's court differs considerably from the criminal court. The primary difference is that coroners employ an inquisitorial process to arrive at a conclusion as opposed to the criminal system which is argumentative (Prior, 1989). As such, during the coroner's investigation, there is no opposition to the investigation or the evidence. An interesting distinction highlighted by a senior coroner was that:

'The CPS (Crown Prosecution Service) only read the evidence, the coroner actually hears the evidence and there's a difference between the two, evidence on paper isn't always the same as evidence heard in court.'

(Coroner, 2)

This distinction highlights the role of evidence in coroners' investigations as compared to the criminal legal system. During a coroner's inquest evidence is gathered and literally heard<sup>23</sup> in court as a way of developing a narrative of the events leading to a death. The presentation of medical evidence can be seen in this light where it is appraised based upon its ability to fit the narrative in terms of its ability to reflect the circumstances of the death.

It is the coroner's office alone that decides where to get expert evidence from as well as what constitutes evidence in each particular investigation. When asked how expert evidence is appraised a senior coroner stated:

---

<sup>23</sup> This is particularly interesting in relation to 'Read Through' Inquests. These are inquests in which no experts have to appear before the court, instead opting to give written statements (Rule 23, Coroners Rules 2008), and which no family members of the deceased are present. Coroners and their assistants go through the motions of the inquest. The Coroner presents the purpose of the inquest, out loud to an empty court, then introduces the evidence which the coroners assistant reads the written statements aloud, standing in the witness box. This serves as a record of the narrative developed in the investigation.

'I test the evidence given by the expert to see if it stands up in court to legitimise them; I have to find factually what happened so I don't really go into the opinion side of expert opinion.

I can either accept the evidence or reject it.'

(Coroner 1)

Testing the evidence in this case reflects the need for the evidence to fit the broader narrative produced from the social and situational evidence pertaining to the circumstances of the death. This is referred to as applying 'judge craft':

'You apply judge craft, there is nothing special about an expert, all an expert is, is a person who is qualified to give opinion evidence. What that evidence says has to be viewed in light of the other evidence. Some expert evidence is rubbish because it is fanciful and doesn't stack up to the circumstances of the rest of the evidence and some expert evidence is excellent. You evaluate the evidence the same way as you evaluate any other evidence, that is the judicial process.'

(Coroner 4)

When Steffan Timmermans (2006) asked a pathologist in his study of the US medical examiner system about what he thought about determining the manner and cause of death based on the corpse alone he similarly answered: "Without scene investigation and medical history, I am lost. I can't do my job" (Timmermans, 2006, p. 70). Coroners conduct investigations and inquests on this basis. Although the Jervis handbook for coroners consistently remarks that death is a pathophysiological phenomena defined by the cessation of the physical functioning of the body (Purchase and Woollaston, 1957; Matthews, 2014), evidence from the post-mortem does not always determine the conclusion of the inquest, social factors are also considered (Prior 1987). For example if someone was found hanged at home with a clear suicide note, evidence by the attending

pathologist that the individual also had obstructed coronary arteries is very unlikely to figure heavily in the explanatory narrative developed in the inquest. The cause of death will still be registered as: 'Pressure on the neck consistent with hanging' (Inquest 2c). This is of course a very simplistic example, coroners cannot always rely on how well the evidence 'stands up' to the other circumstances of the death, particularly in complex natural deaths. One such case was highlighted in an interview with a senior coroner. The death in question was extremely unusual, the coroner had never seen a death like it and indeed the circumstances of the deaths concerned had never been reported. The case in question pertains to two deaths following the transplantation of a kidney to each of them from the same donor. The kidneys in question were, upon post-mortem examination found to be infected with halicephalobus, a rare parasitic worm that most commonly infects horses. This parasitic infection was deemed to be the cause of death in all three men (i.e. the donor and both recipients). Although the inquest had not been heard at the time of the interview, the coroner did discuss how he went about gathering the evidence for the investigation. He explained that it was very much driven by the post-mortem findings:

'So from the PM gateway he (the Pathologist) has actually pooled in about 8 experts of people lined up for this one... There are two specialist professors in England we have gotten to in relation to what would actually have caused the death. Very unusual case so it's a question really of following the right route really but the gateway tends to be the pathologist.'

(Coroner 2)

Who is and is not an expert in this case is less about the ability of the expert testimony to fit the circumstances of the death and more related to the availability of any experts in this area who could attest that this particular parasite could be transmitted via organ transplantation. This was a process that was instigated and followed through by the

pathologist who, for many coroners, constitutes the primary source of medical expertise. Ultimately, the coroner gave a narrative conclusion to the inquest, stating that the two organ recipients died of unintended consequences of necessary medical intervention; registering the death as:

1.A Meningoencephalitis;

1B Halicephalobus nematode meningoencephalitis following renal transplant;

1C Halicephalobus nematode infected transplanted Kidney Pneumococcus meningitis.

(Woolley, 2014)

The quality of medical evidence even in this case is not appraised by the coroner. Coroners have freely admitted that they do not possess the medical expertise to be able to negotiate the medical science:

‘It’s a question of making sure you have got the right pool of experts you can tap into and sometimes that means you will speak to an expert to find out about another expert. You know and that is the safest route really, because if I start to decide myself who is going to be the best cardiologist specialist you know.... so generally speaking the pathologist know precisely what lines of enquiry needs to be made and in circumstances where they have to be made elsewhere they will make recommendations. The gateway tends to be the pathologist that is why a good working relationship is absolutely critical.’

(Coroner, 2)

During the investigation the coroner will commonly defer to the expertise of medical practitioners, particularly to that of the pathologist with whom he/she works most closely. Deference to the expertise and experience of medical practitioners and indeed other scientific experts within the legal domain is common practice, although the way in which

that evidence is appraised by the legal profession is still a highly contended area (Priaulx, Weinel and Goldsworthy, 2016; Jasanoff, 2008). This is particularly pertinent in the coroner's court in which medical evidence is often solicited to establish a narrative of events. While the coroner cannot attribute blame, assumptions of good and appropriate clinical practice can mean the difference between a natural and unnatural death. Whilst this evidence is tested against the other evidence surrounding the circumstances of the death, this does not distinguish whether the action taken within this narrative represents, on the balance of probabilities, what the professional community as a whole would do in the same situation. In such situations, I have witnessed coroners referring to practice guidelines as a way of grounding witness statements within concrete community best practice protocols. During an inquest into the sudden death of a woman in her mid 30's, following admission to hospital due to severe 'thunderclap' headaches, the coroner raised concerns over why the accident and emergency patient did not receive a CT scan soon after her admission. This line of questioning was aimed at the accident and emergency consultant working that evening who was providing a narrative of the circumstances immediately following the patient's hospital admission. This was an issue at stake within this inquest because the junior doctor on call had attempted to order a CT scan but the on call radiology service, which had been outsourced to Australia (which is common practice outside of normal working hours) deemed the scan unnecessary. The radiologist in this situation was presented as holding authority over this decision as they had the responsibility to protect the patient from unnecessary exposure to ionising radiation. It was this dispute about appropriate practices that led the coroner to question what should have been done in this case, specifically asking whether there were any guidelines on this matter. To this, the accident and emergency consultant directly quoted the Scottish guidelines on the diagnosis and management of headaches which states:

'In patients with thunderclap headache, unenhanced CT of the brain should be performed as soon as possible and preferably within 12 hours of onset.'



(SIGN, 2008, p. 7)

The recounting of the guidelines never came into question, the coroner accepted the presentation as fact. The use of guidelines in this case served as a way of settling a dispute in the narrative. This could have had dire implications for the, then patient, however as it transpired during the course of the inquest, post-mortem evidence from a specialist pathologist found a subarachnoid haemorrhage which was deemed to be separate to the reason for initial hospital admission. For the coroner, even though the practice was not in line with the guidelines it did not figure in the conclusion as the timing of the CT did not have a bearing on the circumstances of the death.

## 8.2 The Burden of the Burden of Proof

The use of and consideration given to medical and/or scientific evidence in the coroner's court is not limited to considerations of the extent to which it 'stands up', but is also limited by the constraints and structures of the coroner's system itself and the defined jurisdiction of the coroner.

The primary role of the coroner as a judicial body is to ascertain whether a death is unnatural or natural. This is embodied within the official jurisdiction of the coroner in England and Wales, which is limited to the investigation and determination of four questions, these questions are announced at the beginning of every inquest:

'The role of the inquest is to answer four limited but factual questions; who the deceased was, when they died, where they died and how they came by their death and it is this final question where the majority of the work is.'

(Inquest C1)

It is the final question in which medical evidence figures, although it is important to note that this final question is not designed to establish the legal cause of death, but is instead a tool for categorising the death into predetermined categories. These categories are the short-form conclusions that the coroner can come to and include: Accident or misadventure; Alcohol/drug related; Industrial disease; Lawful/unlawful killing; Natural causes; Open; Road traffic collision; Still birth; and Suicide (The Coroners (Inquest) Rules 2013). This is not an exhaustive list and there is an emerging trend in which coroners use the option of a narrative conclusion, for deaths that do not neatly fit within these categories (Coroners Statistics, 2014).

For coroners' work, the distinction between a natural and unnatural death is of utmost importance (Prior, 1985), represented in the burdens of proof necessary to define the

cause of unnatural deaths compared to natural deaths with the former being beyond reasonable doubt and the latter equating to the balance of probabilities (Note iii, Schedule 2, The Coroners (Inquest) Rules 2013). Moreover, recent changes in legislation further formalise the devaluation of natural deaths. The Coroners and Justice Act 2009 now allows for coroners to close an investigation and register a cause of death where it becomes apparent that it was of natural causes without having to go through the formal inquest proceedings. This prioritisation is also apparent in coronial practice, as one pathologist discussed with me:

“The coroner, as soon as it’s natural causes they have no jurisdiction. The old coroners used to say ‘I don’t give a damn whether it’s a stroke or a heart attack, its natural I’m not interested, for death certificates, for provision of future resources for the NHS, it is important, but for the legal process ‘is this natural, is this not?’”

(Cardiac Pathologist 3)

Coroners need to record a legal cause of death for all cases they investigate (The Registration of Births and Deaths Regulations 1987). For natural deaths, this needs to satisfy the balance of probabilities, equating to ‘51% certainty’ (Coroner, 4). The primary process through which a coroner will establish a natural cause of death is through the examination of medical evidence, this being either medical records, or where these do not unveil the mechanisms of death, through a medico-legal post-mortem. These post-mortems are carried out by NHS pathologists where the death is not thought to be criminal (i.e. natural death or suicide).

What is at stake within the discussions around the burden of proof in this setting are issues of whether the coroner has made sufficient enquiries. Indeed coroners can be held accountable for making insufficient enquiries. However, the sufficiency of the enquiry is not denoted by the quality of the evidence per se, as was the issue at stake in *Daubert v Merrell Dow Pharmaceuticals, Inc.* 509 U.S. 579 (1993) (Jasanoff, 2008), although:

'You wouldn't instruct a geriatrician to give a report with regard to a cardiovascular problem.'

(Coroner 4)

Instead, the sufficiency of the enquiry is measured against the ability of the evidence presented in court to achieve the legally admissible burden of proof on the balance of probabilities. Going beyond this has been likened to 'opening the flood gates' (Coroner 7).

### 8.3 The Political Construction of SADS as a Cause of Death

SADS is a recognised cause of death for the coroner and is acceptable for registration purposes, however the mode by which a coroner will come to the decision to use SADS as a cause of death is not straight forward. This is for the most part due to the pathological characteristics of many conditions associated with SADS in the clinic, which are defined by their lack of pathological presence, often only visible for clinicians through the ECG. Of course, there are many other circumstances in which a person could come by their death in the absence of pathophysiological findings post-mortem, such as epilepsy (SUDEP) or other unnatural causes of death. An example of this could be where a body is found submerged in water that has been there for a prolonged period of time, in these cases it is impossible for a pathologist to ascertain whether there were pathological features which could have caused the death due to decomposition. In these cases the coroner often concludes the inquest as 'open' and registers the cause of death as 'unascertained'.

However, in cases of suspected SADS an inquest will rarely be concluded as 'open' nor will the cause of death routinely be registered as 'unascertained'. This is partly due to the resistance by coroners to register a cause of death as unascertained, perhaps explained by the transition into a 'Risk Society' (Beck, 1986), in which there is an agenda to understand and control risk and any divergences from this, where risk remains unknown, causes social anxiety. Indeed this is reflected in historical trends in death investigation. Lindsay Prior's work examining the Coroner's service in Belfast (1989), explicitly discusses this transition. He gives the example of the historical transition in death categorisation from the 19<sup>th</sup> century coroner where it was relatively common, particularly where no pathology was found, to categorise a cause of death as a 'Visitation from God' (1989: p.61). Following the 1887 coroner's reforms this changed. This can be seen as a transition from the 'Tamed death' (Airès, 1974) in that there was an existential understanding that death was

inevitable. There was not a concern over the cause of death, instead fatalistic or religious explanations were given. However, following what Foucault considers (1963) the birth of modern medicine, the mechanism by which people came by their death has become increasingly important. As such, establishing *a* cause of death has become increasingly important for death investigators. It is at this point that specialist medical evidence<sup>24</sup> began to gain prominence in the coroner's court. This began firstly through the campaigning work of surgeon, coroner and MP Thomas Wakely, who was largely responsible for the introduction of the Medical Witness Act of 1836, which gave coroners the power compel medical witnesses to testify and order them to conduct an Autopsy examination. In similar force, aspects of the Births, Deaths and Marriages Act 1837 further entrenched coronial powers in determining that only coroners had the authority to register deaths that were unexplained or suspicious following an investigation.

In practice, the process of establishing the cause of death is far less idealistic; it is a process muddied by complex political, economic and indeed moral considerations. This is not to say that the desire to unveil the mechanisms of death where they are otherwise unknown is entirely absent, however the practical achievement and public presentation of this is not straightforward.

Coroners claim the 'license and mandate' (Hughes, 1971) to determine that which is associated with suspicious or unknown deaths. They define what caused the death as well as defining the means by which a person can come to a cause of death. This is supported by law as well as the historical supremacy the coroner has had over this field of knowledge and practice. However, professional authority is not taken for granted, nor does it remain unquestioned (see Klinenberg, 2002 for a discussion of how the professional authority of medical examiners can be questioned). Professional authority is maintained by those who

---

<sup>24</sup> Before such moves, the coroner had the power to investigate the cause of death himself (there were no early female coroners) including dissections, which were commonly held in public houses to avoid accusations of bias, although the practice of autopsies in public houses is now illegal, remaining in legislation to this day.

possess it. Kathy Charmaz (1976) encompasses many of these concerns when discussing the strategies by which coroners (or their deputies) notify relatives of a sudden unexpected death, noting a key task is to make the death credible, accountable and acceptable. This is also reflected in Sudnow's (1967) reflections on how physicians often presented deaths to families in line with acceptable medical categories, such as heart attack, as well as presenting the circumstances of the death within the acceptable narrative of a peaceful, painless death. Clive Seale (1998) best summarises the importance of coroners constructing acceptable accounts of death:

'The task of the living is to enclose and explain death, reduce its polluting effects, and symbolically to place individual deaths in a context which helps survivors turn away from death and towards continuing life.'

(Seale, 1998, p. 81)

Thus if coroners do not fulfil their 'jurisdiction' (Abbot, 1988) in locating death within a socially accepted definition of where death should be located, public anxiety results and the professional authority of the coroner can be questioned.

I have only observed one (of 15) inquest in which the coroner gave an open conclusion. The purpose of this inquest was to investigate the death of a woman found at the bottom of an inner city canal. The evidence presented at the inquest consisted of a statement from the woman's son, the findings from the post-mortem from the attending pathologist (written statement), a statement given by the police officer first on the scene where the body was found, and a written statement from the woman who found the body in the canal. The inquest began, following the formal introduction of the role of the coroner and the inquest, with the statement from the son. The coroner asked a series of questions aimed at gaining biographical information; she asked what his mother was like, and asked about her previous drinking problem, as well as asking about the days leading up to the deceased estimated time of death. However, the witness had not recently seen his mother,

they had arranged to see each other but she did not turn up. The coroner then asked again about his mother's previous alcohol problem, the witness responded that she no longer had a drinking problem. The purpose of this was to establish a narrative which could lead to an appropriate cause of death, in this case the possibilities were suicide or accident. Ascertaining a narrative of the days leading up to the woman's death could serve to establish her state of mind, whether there was any suicidal intent or behaviour such as heavy alcohol consumption, which could be conducive of an accident.

The statements from the police officer and the person that found the body were more focussed on the period following the death, whether there were any suspicious circumstances for example, as well as establishing the situation in which the body was found. The police officer confirmed that there were no suspicious circumstances, but also that there was no evidence which could rule out 'foul play' (i.e. there was no CCTV in the area or any witnesses to confirm how the deceased ended up in the canal). The witness who came upon the body offered a description of how the body of the deceased came to her attention. She explained how she thought she saw a thick coat floating on the canal but on closer inspection realised that the dark colour of the large coat obscured the visibility of the woman's body. Upon realising this, the witness immediately contacted the police.

The final piece of evidence heard in court was the statement from the pathologist which detailed the findings from the post-mortem examination. A summary of this statement was read out by the coroner<sup>25</sup>. The coroner focussed her attention on the toxicology screen which she summarised by saying that no significant levels of alcohol or drugs were found. She continued on to the pathologist's comments and summary, to 'spare the tedious detail of the form' for the family who were present (the surgical details of the post-mortem, such as the weight of each organ was not pertinent to the investigation). The summary read:

---

<sup>25</sup> Witnesses are not always required to physically appear in the coroner's court and can submit a written statement under Rule 23 of the Coroners' Rules 2008, which states that written statements are admissible on the basis that the evidence is unlikely to be disputed. The rationale for this is to make the inquest process more efficient.



‘The body was found as a result of drowning, there was no evidence of a traumatic incident. 1a. Drowning<sup>26</sup>.’

(Inquest B3)

The pathologist’s statement says nothing about how the individual came to drown, simply that the pathological evidence is consistent with drowning.

The family present were visibly dissatisfied with this conclusion. Following the pathologist’s statement, the family present were given the opportunity to ask any questions based on the evidence presented. They simply asked; ‘Why did she drown?’ reiterating the fourth question to be ascertained during the inquest, to answer ‘how the deceased came by his/her death’ (Coroners Rules 1984, Rule 36). To which the coroner replied:

‘We don’t know why she died. On the available evidence it is clear she drowned, however there is no evidence to reach a conclusion as to how she died, as such I must reach the conclusion of open.’

The family in this inquest were left wanting further answers. They asked if there was going to be a police investigation (which there was not) and left with no more answers than when they arrived, aside from the pathological fact that her body ceased to function as a consequence of drowning. The death remains a mystery, the coroner failed in symbolically placing the death in an acceptable, meaningful category. The consequences of this can directly impact the professional authority of the coroner, although this happens ‘very rarely’ (Coroner, 4). Coroner’s decisions can be judicially reviewed, and as can be seen in the preface to this thesis much of the rationale for judicial review is predicated upon a dissatisfaction with the coroner’s conclusion.

---

<sup>26</sup> 1a refers to the categorisation of the cause of death necessary for the death certificate, it is the space on the form in which the primary cause of death is given.

Leaving an inquest open or concluding the cause of death unascertained is actively avoided by coroners and pathologists. This aversion is based on the assumption that offering a cause of death serves some sort of social function:

'It's useless to put unascertained, because it's meaningless it serves no purpose.'

(Cardiac Pathologist 6)

The use or purpose of providing a cause of death is reflected upon by this paediatric pathologist in relation to the direct implications for families of the deceased. When I asked this pathologist whether he used unascertained he answered:

'That doesn't go down terribly well with families, I mean there's nothing worse than going to an inquest and the family are there and they look at you and you are saying I don't know and they look at you as if to say: 'how can you not know?'. It really is awful... they just look so disappointed that you can't you know... To say unascertained means... almost to say you are not trying or something its psychology more than anything else it has nothing to do with accuracy, you can be brutally frank and say I don't know, but that just makes you seem like you are shrugging your shoulders and saying I don't care.'

(Paediatric Pathologist)

This same pathologist reflects on the ambiguity of unascertained:

'Unascertained means to some people 'I think this is a bit dodgy', some coroners will sort of think 'I think this chap has been done in but we can't prove it'. Other people will take unascertained as literally that, 'well we don't know' and others will take it as natural causes. You know if you have got 50 coroners, you are going to have 50 different interpretations of fine gradations of meaning and families are extremely sensitive to that sort of thing.'

(Paediatric Pathologist)

There is a general aversion among the medico-legal community to use the label unascertained because of precisely these reasons, to the extent that this pathologist can only recall using the term in regards to one death which he described as presenting absolutely no possibility for establishing cause of death. Like many deaths finally categorised as unascertained, the barriers to establishing the cause of death arise during the time after the death, as time passes decomposition slowly destroys any pathological evidence which may unveil the cause of death. However, for this pathologist the pathological evidence was destroyed markedly quicker:

‘it was a dreadful case, a child died suddenly and was put in the fridge in the hospital and they hadn’t monitored the fridges and basically the baby was cooked over the weekend and it was... it was unascertainable I couldn’t get anything from it and I did actually use the term not ascertainable or something similar at least.’

(Paediatric Pathologist)

As a consequence of this aversion coroners and pathologists have techniques to overcome the use of this term, there is a process of re-categorisation, naturalisation and leaning upon normative assumptions based on experience in designating causes of death.

#### 8.4 'Do you want *A* cause of death or *The* cause of death?'

Much of this can be discussed in relation to a comment relayed to me by a coroner, originally from a reflexive pathologist:

'One of my pathologists encapsulates this whole thing very beautifully, which is the nub of professional issues between pathologists and coroners. He said: 'You need to decide, do you want a cause of death or the cause of death', it's his way of asking about specificity, or in other words, 'I can have a cause of death that is natural and sign off' or do I want the... how specific do I want to be?'

(Coroner 1)

Law mandates that the coroner investigates sudden and unexpected deaths. However the extent of this mandate is limited, the coroner acts within the limitations of his/her jurisdiction. In the investigation of natural deaths, this jurisdiction is limited to satisfying the balance of probabilities. There are also financial considerations to delving into the cause of death 'to the Nth degree' (Coroner 1). The standard medico-legal post-mortem in the UK is charged at £98. While further investigations can be requested by the pathologist, such as histology or toxicology, coroners nevertheless have very limited resources so must ration those available based on need. The result of this is that if a pathologist can establish a cause of death on the balance of probabilities without the use of further testing then the coroner will accept this.

As a result of these pressures there have been growing concerns over the quality of the medico-legal post-mortem in the UK, with stories circulating in the pathology community of the '7 minute post-mortem'<sup>27</sup>. This came to a head when prominent pathologist Sebastian Lucas, with support from National Confidential Enquiry into Patient Outcomes

---

<sup>27</sup> Anecdote given at European Cardiac Pathology conference.

and Death (NCEPOD), produced the report *'The Coroner's Autopsy: Do we deserve better?'* (NCEPOD, 2006). This report heavily criticised the practice of pathologists when conducting medico-legal autopsies, suggesting that practice was incredibly varied across the UK and proposed a process of standardisation through accountability mechanisms such as peer reviews of reports and practice. However, this report has had very little practical impact, with the Royal College of Pathology claiming that coroner's work is not their responsibility, they deal only with clinical pathology (Cardiac Pathologist, 4). This is represented within the standards for Coroners' post-mortems released by the Royal College of pathologists (Leadbeater et al, 2014) following the NCEPOD review. This guidance recommends that agreements regarding quality, transparency and accountability of pathologists work are matters for the coroner. Thus, although this guidance sets out recommendations for best practice when conducting a coroners' post-mortem, the audit and evaluation of this practice remains out of the Royal College of Pathologists' hands.

Ischemic or Coronary Heart Disease is the most common cause of death in the UK accounting for 14.8 % of all male deaths in 2014 (Office for National Statistics, 2015), and although there are no official statistics on this, pathologists consistently report that the underlying cause of death in the majority of post-mortems they undertake is ischemic heart disease:

'Heart disease is the most common cause of sudden death, so that when we perform the autopsies and particularly when the juniors are doing them, they are trained to... try and investigate the causes of cardiac disease.... ischemic heart disease accounts for about 80% of the cases.'

(Pathologist 1)

Indeed Timmermans (2006) states that coronary heart disease accounts for around about 75% of all sudden deaths. Lindsay Prior (1989) similarly reported that 'circulatory disorders' accounted for 19% of deaths in women and 31% of deaths in men certified by

the coroner in Belfast in 1981. I mention this in the same breath as commentary on the specificity of the medico-legal post-mortem and the limitations upon pathologists when conducting such investigations because there is a sense in which this kind of heart disease can be invoked as a normative expectation. As Timmermans (2006) notes pathologists *make the case for Heart Disease*. He notes:

‘...there is no real measurement besides “eyeballing” the arteries... I observed that under some circumstances, lesser obstructions could qualify as the underlying cause of death.’

(2006, p. 60)

He goes on to say that in particular circumstances coronary heart disease would be given as a cause of death without physically seeing the occluded artery. In these cases the pathologist could say on the balance of probabilities, weighing up the circumstances of the death, that the person probably died of a ruptured or occluded blood vessel in the heart without opening the person up. This judgement is based on personal experience as well as collective experience as a professional group. Pathologists ‘know’ that the majority of people over the age of 60 will have some amount of plaque in their arteries. This routinization (Bloor, 1991) underpins the emergence of normative practices; if a pathologist ‘sees’ coronary artery disease 80% of the time it becomes a normative expectation. This is made possible due to the relative lack of repercussions for getting it wrong, as reflected upon a practicing pathologist in 1904:

‘When a stranger does the autopsy he magnifies natural appearances into morbid ones, and makes a statement accordingly – a statement which nobody cares or perhaps can controvert.’

(Smith, 1904, p. 39)

There is little in the way of review of pathologists' medico-legal practice, as there is in clinical pathology, thus any mistakes go to the grave with the patient. However, the distinction to be made is whether the individual died *with* ischemic heart disease or *of* it. Where there is little in the way of other pathology to be found, coronary heart disease can often foot the bill.

A cardiac pathologist was discussing this in relation to his training:

'When I was a junior pathologist, I remember my boss was a forensic pathologist and a heart pathologist and he told me to do this case of a 40 year old man I did the autopsy and nothing, and he stood over me and said 'ooh that's a bit funny make sure you take lots of histology' which I did and that was all normal. So I showed it to him and he said 'that's a bit funny, better write that up as ischemic heart disease'. I said 'I can't do that professor there wasn't any', and he said 'oh you probably just missed it' and so at that time when we had these difficult younger deaths we did fabricate their results.'

(Pathologist 1)

This again positions the importance of establishing *a* medically acceptable cause of death as high on the agenda, as well as the avoidance of not being able to give an explanation as to why the individual died. This pathologist goes on to explain when this changed:

'It wasn't until Michael Davies had the courage to say 'look guys let's be honest these cases exist' as you know of course. So the first SADS I signed up would have been about 1990 from then on.'

(Pathologist 1)

Michael Davies brought this issue of autopsy negative sudden cardiac deaths to the attention of his professional peers and indeed the public (Davies, 1992). This marks an

important shift in death registration and offers an interesting insight into the professional agenda of death investigators. The importance of understanding the mechanisms of death has been seen as a hallmark of modern society (Beck, 1986; Giddens, 1991; Foucault, 1963). At the same time, the ways in which we know and understand death have been increasingly thought of as socially constructed (Atkinson, 1978; Douglas, 1967; Prior, 1989; Bloor, 1991). This extends the role of the death investigator from the 'death broker' (Timmermans, 2005) placing deaths into acceptable categories (Charmaz, 1976) to the role of actually constructing acceptable categories in which to place deaths that would otherwise remain unacceptable. This can be seen in relation to the way in which coroners and pathologists construct what SADS is within the confines of their jurisdiction as can be seen in the following section.



## 8.5 Making a Case for SADS

Michael Davies instigated this process of re-categorisation in his 1992 paper in which he called for the construction of the category of sudden unexplained death syndrome to describe a particular subset of autopsy negative sudden deaths:

‘When all these diagnoses have been considered there will still be some people with no history of chest pain, palpitations, or syncope and no cause of death shown by the most careful necropsy. The size of this problem in Britain is not known because there is no agreed nomenclature for categorising and recording the cases... Some coroners in England and Wales accept a diagnosis of "natural death-cause unascertained"; others do not. A pathologist may be tempted erroneously to ascribe death to ischemic heart disease... It would help bereaved families and scientific knowledge if a category of sudden unexpected death syndrome was recognised. Many pathologists and coroners have arrived at this sensible point by mutual agreement. There are certain analogies with the sudden infant death syndrome. Both conditions are probably heterogeneous, and in both necropsy does not explain the cause of death. The existence of the category sudden infant death syndrome has, however, not only helped research but also given families a feeling that they understand, and can begin to accept, the death.’

(Davies, 1992, p. 539)

This is the first paper in which there is an attempt to create a category for what are now known as SADS related deaths<sup>28</sup>. This follows an earlier study that Davies had been involved in (Thomas et al, 1988) that identified a small number of sudden deaths in which

---

<sup>28</sup> The term SADS referring to Sudden Arrhythmic Death Syndrome came into use following Behr's et al. (2007) national survey of sudden unexplained cardiac death. SADS (sudden adult death syndrome) was increasingly used by coroners at this point, however Behr and colleagues found a proportion of these deaths in children and thus they replaced adult with arrhythmic to represent their finding that this did not only affect adults.

no morphological features were found during necropsy, but were nonetheless considered to be of natural causes. In this study, they express dissatisfaction that there is no category of sudden adult death as there is for sudden infant death syndrome (SIDS). There are similarities that arise when comparing the development of SADS with SIDS as categories of death although SIDS came into use 20 years earlier. SIDS was a product of the Second International Conference on Causes of Sudden Death in Infants in 1969 held in Seattle (Beckwith, 1973) which defined sudden infant death syndrome as:

‘The sudden death of any infant or young child, which is unexpected by history, and in which a thorough post-mortem examination fails to demonstrate an adequate cause for death.’

(Beckwith, 1973, p. 5)

The primary similarity between SIDS and SADS is that they are arrived at through a process of exclusion. A pathologist can only categorise a death as SADS or indeed SIDS by excluding all other causes of death which could be seen during the post-mortem or that which could be reasonably considered to cause the death. This is reflected in the use of SADS in contemporary medico-legal practice in the UK by both pathologists and coroners:

‘[when] somebody is apparently healthy suddenly drops dead; there is no suspicious circumstances, toxicology negative I think I would probably use the SADS label.’

(Cardiac Pathologist, 6)

‘I’ve used SADS before as a narrative conclusion... and that’s where a pathologist comes back as unascertained and then we go to an inquest.’

(Coroner, 9)

SADS, in medico-legal practice means that the cause of death remains undetermined.

Timmermans (2006) suggests that such diagnoses of exclusion (referring specifically to the use of SIDS by medical examiners) serve as 'stopgaps' in Abbott's (1988) terms, in that they represent a problem for which the profession currently lacks an adequate answer.

This is for the most part true for the use of SADS by coroners and pathologists, in that SADS serves as a box in which to place a group of deaths that the profession cannot yet explain. Much like Timmermans' claim for SIDS, the category of SADS is a successful professional accomplishment, serving to give feelings of understanding to family members and society in the broader sense, which places value in knowing why and how people die, even where no explanation can actually be given. This is particularly important for coroners and pathologists whose professional legitimacy rests on their ability to unveil the mechanisms of death. Thus, SADS gives the fallacy of understanding and as such has been accepted as natural cause of death, it has naturalized the unknown into a socially validated category - however 'stopgaps' do not simply endure, they need maintenance.

The continued success of SADS is a practical achievement for the coroners' system of England and Wales. There is a legal and economic infrastructure in place to ensure SADS remains a legitimate and acceptable cause of death that serves to protect the coroner's jurisdiction over this domain. Although coronial legislation and economic constraints limit the potential investigations that can be undertaken within the death investigation, there is also a sense in which coroners can employ these limitations as a way of justifying actions.

As per the intention of Michael Davies, the recognition of a distinct group of sudden unexplained deaths has resulted in investment in research and health service provisions to identify and prevent these deaths, however the impact upon coronial practice has been limited. By drawing on 'the law' within discourse and practice, coroners build themselves 'market shelters' (Friedson, 1986), which enable them to resist technological and medical developments in the understanding of ICC's. This is not positioned by coroners as

resistance but instead as the limitations of their jurisdiction which makes technological developments inappropriate for their work. This dual relationship between a resistance towards a technology and the usefulness (Hedgecoe, 2008) of the technology to serve a purpose (Clarke and Fujimura, 1992) for professionals performing their jurisdiction, can have profound impacts upon the shape that both the profession and the technology takes. This will be discussed in detail in the next section in which the case of the molecular autopsy will be taken to discuss how useful genetic technologies are in the medico-legal investigation.

## 8.6 The Place of Genetics in Coronial Practice

The molecular autopsy developed out of the field of cardiac genetics, initially as a way to establish the cause of death following the sudden unexpected death of a young person. The molecular autopsy was developed by Dr's Tester and Ackerman of the MAYO clinic in 1999 as a way to provide a diagnosis of a young woman who died after a near drowning (Ackerman et al, 1999). The genetic testing technology that constitutes the molecular autopsy has successfully translated into clinical practice and genetic testing is part of the diagnostic pathway for many ICC's across the UK to a greater or lesser extent (See Part I). However even though it has a proven utility in the medico-legal setting in that it can help establish *the* cause of death (i.e. the particular channelopathy or cardiomyopathy for example) it has yet to make the transfer into common medico-legal practice, and remains to be used solely in the research setting.

This can be presented as a way in which the coroner's system is structurally and practically resistant to change, which is enabled through the mobilisation of their legal mandate (Hughes, 1958). Coroners present themselves, above anything else as legal practitioners. That they perform their role in line with the boundaries of their formal legal jurisdiction becomes apparent when discussing how a cause of death is established. During a conversation with a senior coroner about the weight given to evidence by a particular pathologist she said:

'...if she is right or wrong and I am almost sure she is right, it is on the balance of probabilities what she believes it is.'

(Coroner, 3)

It is this balance of probabilities that can denote the extent to which a coroner investigates a death:

'It would not in my view normally be... necessary to establish whether a particular gene for example can be identified any more than if somebody certified that somebody has a cancer, what sub group of cancer it is, because the duty of the coroner is to establish whether the deceased dies a violent or unnatural death, and if it is established as a natural death on the balance of probabilities he has fulfilled his duty. So it would not be my experience that every case would enquire further into the details, for the purpose of the coroner, of the aetiology.'

(Coroner 7)

The balance of probabilities when investigating a natural death can then be employed to denote the limits of the explanation given by the coroner during an investigation. The rationale for this is that by not imposing the limits of their own jurisdiction there is the risk of 'opening the flood gates' (Coroner, 7). Talking specifically about his resistance to the general use of genetic testing as a way of delving into *the* cause of death, this senior coroner uses 'the law' to argue that this technology is beyond his jurisdiction:

'If one starts with the presumption that a genetic test should be done by the coroner as part of this [defining the aetiology of SADS] presumably that would apply to any other condition, there would be no reason that this particular condition should have different treatment. So would the argument then be that we should establish the extent of genetic inheritance of a whole range of diseases? It would seem then that the scope of an inquest has been expanded hugely.... Not only cost, but actually there are almost moral and ethical issues here if we are to follow to the Nth degree the aetiology of every disease we are going far beyond what is

normally considered by the law as acquiring and accuracy... how specific do I want to be? I would argue that it's not required by the law.'

(Coroner, 7)

Presenting the law as well as themselves as having the sole purpose of enacting the law, the coroner can effectively denote the boundaries of his/her jurisdiction. This coroner is arguing that this becomes a moral and ethical issue, to overcome the issues of how far to go into the aetiology of causes of death law is invoked.

'The law' is not only mobilised at this general level to denote boundaries of the coroner's investigation but is also presented as an oppressive force which limits the action that the coroner and pathologist can perform. The oppressive force of the Human Tissue Act 2004 (HTA), dominated conversations around the use or not of the molecular autopsy in the medico-legal autopsy. This was not such an issue for coroners but it was embedded in the consciousness of practicing pathologists. The HTA was developed as a consequence of a few high profile scandals, the most notable of which was the Alder Hey hospital scandal which came about from the findings of the Royal Liverpool Children's Inquiry (2001). This inquiry outlined the practices of pathologists at Alder Hey Children's Hospital particularly pertaining to the removal, retention, storage and disposal of children's organs and other human tissue including histopathology slides, without the express consent of the next of kin of the deceased. The practices described in the report and recommendations held there within have been in hindsight categorised as 'macabre' and 'highly emotive' (Dewar and Boddington, 2004). Although it has been recognised that the actions of one individual, Professor van Velsen, rightly concerned the public and those who constructed the Alder Hey report (Burton and Wells, 2001), public outrage through intense media attention at the time has had a dramatic impact on the public perception of pathological practice. Indeed the sensationalisation of this scandal put the pathological profession under a great deal of scrutiny, which remains to a greater or lesser extent today (or at least pathologists

report feeling more under scrutiny). Seale and colleagues (2006) report how the media played a divisive role not only in the aftermath of the Alder Hey scandal but also in the development of the scandal itself. They describe how the *Liverpool Echo* and *Daily Mail* reporting on a statement from a physician in a Bristol hospital during an inquiry unveiled that there was a collection of hearts at Alder Hey hospital and that by virtue of its existence our knowledge pertaining to paediatric cardiac surgery was greatly improved. However, these newspapers reported the issue from the parents' perspective, presenting what was common practice as something that was morally questionable, as well as using other sensationalist language associated with horror films, explicitly targeting pathologists as morally questionable in their profession. Seale et al. (2006) go onto say that this media attention had very real impacts in the shaping of the HTA as well as on the practices and attitudes of pathologists who report to be demoralised (Burton and Wells, 2001).

The HTA then, is considered to be a reactionary response to public (media) outrage (Kaye, et al, 2016), and as having consequences for the everyday practices of pathologists who perceived their practices to be well within the realms of the law as well as what was considered moral and ethical:

'The van Velsen guy over in Liverpool who was the Alder Hey chap, he should go to prison, that's illegal, and I think it was a loss to this country that they actually let him go... It was wrong... You know instead of which we had one person who screwed it all up, you know punish him not the rest of us, we had a system which worked perfectly well, we didn't need this extra enforcement.'

(Cardiac Pathologist, 4)



There is a sense in which the developments in the HTA prevent pathologists from performing their role as they should, as had been historically mandated by the Royal College of Pathologists:

‘The Royal College of Pathologists [recommended] that all PM’s should contain routine histology of all the major organs before the HTA (Human Tissue Act) before the you know alder hey scandal and so on and. If you left pathologists to themselves they would happily keep spleen or anything else really and so what you need to do is undo some of the damage the HTA has caused and make everyone aware that keeping spleen for harvesting DNA for genetics is not a wicked thing to do.’

(Cardiac Pathologist, 5)

The HTA is seen as damaging to the profession, it villainized practices that were once considered standard. Although I have no reports of any adverse action taken towards pathologists by the Human Tissue Authority<sup>29</sup>, there remains a fear that they will be accountable for not taking appropriate consent for taking tissue or for disposing of tissue in the wrong way according to the Human Tissue Act<sup>30 31</sup>.

The HTA does have important implications for the practicalities of using the molecular autopsy. Although the HTA does not cover the storage of genetic data, it does cover the removal, storage and disposal of human tissue for the purposes of the coroner. To discuss the implications of this it is important firstly to emphasise the utility of the molecular

---

<sup>29</sup> The Human Tissue Authority is the regulatory body charged with regulating the removal, storage and disposal of human tissue.

<sup>30</sup> During conferences and incidental conversations there were reports of a fear of going to jail for 3 years for not abiding by the rules of the HTA, although no pathologist could give an example of when this actually occurred. The possibility of conviction is outlined in the HTA (Part 1, Chapter 5, para 7).

<sup>31</sup> The HTA makes it clear that tissue can only be taken without consent from the next of kin for the purposes of the coroners’ investigation and that this tissue can only be used for the purposes of this investigation. Following the conclusion of the investigation tissue can only be stored for the purpose of future education and research with the express consent of family members. In all other cases, tissue has to be disposed of according to the wishes of the family of the deceased.

autopsy. Although Ackerman et al. (1999) initially envisaged the molecular autopsy to be a tool for establishing why a young person died, the true implications are much the same as has been discussed in relation to genetic testing for ICC's in living patients i.e. the implications lie in the risk stratification of family members, not for the patient themselves. This is represented in the Ackerman paper in which they report that the gene mutation they found in the woman who died following a near drowning was cascaded to 50 first-degree family members. As a consequence of this, the sister of the deceased is receiving treatment for LQTS. As the primary implication of the molecular autopsy is for surviving family members and not for the identification of the cause of death, not only does this bring up interesting points about whose jurisdiction the use of the molecular autopsy lies in, but also legally, whether it can be used under the constraints of the HTA. This was emphasised to me by a coroner:

'Coroners CANNOT TAKE TISSUE TO ASSIST THE LIVING. Their role by law is to ascertain the cause of death, therefore any tissue taken must be done so for this purpose.' [emphasis added]

(Coroner, 10)

This coroner is reporting section 11 of the HTA, which states that the HTA does not cover the collection or retention of human tissue for the purposes of the coroner. What this means in practice is that once the coroner is satisfied that all investigations relating to the deceased body have been undertaken, the body must be disposed of or stored in accordance with the wishes of the next of kin. This includes any and all tissue including histopathology slides and tissue taken for further investigation. This also means that tissue cannot be taken for purposes that go beyond the remit of the coroner. The practical impact of this is that even if the coroner did take tissue for their investigation, which would also be appropriate for the molecular autopsy, according to the HTA, it could not be used for this purpose because this test would go beyond the burden of proof for the

purposes of the coroner. In addition, any tissue taken for the purposes of the coroner's investigation cannot be used after the investigation for any other purposes without express consent from the next of kin to store the tissue for the purposes of future research.

Although the only major practical impact of the HTA is one of introducing more stringent consent procedures for the collection, retention and disposal of human tissue there remains a sense in the pathology community that this legislation has greatly damaged their normal practice resulting in a reluctance to take and store human tissue. This brings into question the way in which the law, in this case the HTA and in the previous case the Coroners and Justice Act, actually controls the boundaries of the action available to coroners and pathologists. These professionals mobilise the law as a way of enforcing their own jurisdiction, as a way of resisting change, maintaining their own professional market shelter. Whether coroners and pathologists resistance to the molecular autopsy is an example of the maintenance of a market shelter (through the mobilisation of the law), or as a result of the way in which the developers of the technology have not considered the constraints upon professionals in this setting, and the molecular autopsy is simply not useful, is hard to say. Undoubtedly the answer lies somewhere in the middle, however there is far more to the culture of the medico-legal death investigation that also has implications for the uptake of the molecular autopsy. As is the case in the clinical setting, economic factors also penetrate considerations of whether or not to use genetic technologies. Much of this is down to the argument that, although the price of genetic testing is decreasing at a dramatic pace, it remains disproportionately expensive compared to other diagnostic tests used to establish the cause of death. As stated earlier, the standard rate at which post-mortems are charged in the UK is £98, with 95% of all coroners' post-mortems charged at this rate in 2014, and only in 21% was histology and in 15% was toxicology ordered (Ministry of Justice, 2015). Although there is no standard rate at which these tariffs are charged due to the variation in the amount of tissue blocks taken for analysis and the toxicology tests ordered, NCEPOD (2006) reported the cost per block

of histology was £31.51 up to a maximum cost of £228.50. These costs, when compared to genetic testing, are negligible, nonetheless the increased cost is reported to have an impact on the limited amount of histology taken as part of the post-mortem, with pathologists consistently reporting that they would like to take more. In fact, the majority of the pathologists I have visited speak of paying for the histology out of their fee, or at least analysing the histology slides in their own time for no fee:

'I spend an hour looking at histology, which I pay the lab out of my own fees, my fee from the coroner... There is no extra money for cardiac histology... we have all done this at personal cost.'

(Cardiac Pathologist, 4)

When this is compared to the molecular autopsy, which at the time of conducting the research was reported to cost around £1000, cost becomes a real issue. This is presented as an issue for coroners not just with the test being beyond their jurisdiction, but also in terms of their accountability to local authorities. The structure of the coroners' system of England and Wales separates each coroner's jurisdiction based upon the local authority(ies) the service resides in and the funding for the service is allocated by each local authority. In practice this means that there is great variation between coroner's services, but it also means that each senior coroner must justify their expenditure on a regular basis and resource allocation and expenditure is distributed within the service by the coroner themselves. They choose how much is allocated to histology and other specialist examinations and where there is unusually large expenditure they must personally justify this to their local authority:

'I. Whilst it is the coroner's decision [to spend resources], under the new Act the coroner has to report unusual expenditure to the local authority... Now this does not give the local authority permission, or power to refuse it but it does give them

the opportunity to challenge what seems an unreasonable condition. I would anticipate that genetic tests are probably quite expensive.

C. I think its £500 per gene.

I. There we go. I would have thought, the local authority might well wish to challenge it. I would be reluctant to be in that position unless it seemed to be a matter that was absolutely critical. I have to be mindful of the public purse in that sense, not that the purse prevents me from doing my duty, but in interpreting the scope of the inquest I would be mindful of the potential of a legal challenge.'

(Coroner 7)

Referring here to the Coroners Allowances, Fees and Expenses Regulations 2013, he is not simply identifying that it is impractical to request a molecular autopsy in a system subject to increasingly diminishing resources, but also reflecting on what is at stake with any decision associated with unusual expenditure. He positions himself as accountable for economic decisions and subject to scrutiny. He is not simply saying that he cannot afford it, but rather that he could order the test if he so wished but would have to justify his actions. This then becomes an issue of professional integrity, in which his practice explicitly impacts on perception of his ability to perform his duty as a coroner. There are, as he suggests, legal consequences for digressions from what is normally expected of a coroner when performing his duties. These are bound up with professional economic conflicts - he has to both protect the public purse but also ensure that he fulfils his jurisdiction as the coroner. This has the effect of limiting the investigation, not to the extent that he is unable to fulfil his duties as a coroner as prescribed by law, but makes going beyond what is legally required difficult.

It is this more nuanced account of the jurisdiction of the coroner which is helpful in understanding the use (or not) of the molecular autopsy, or indeed any other change in

practice. What becomes apparent in the above discussion of these economic considerations is that coroners have a lot of freedom. In many respects they can shape their own jurisdiction, because of their relative autonomy from central governance. One coroner expressed this very well:

‘Even now certain practices in the South East are very different to the practices in the North West. So, when we then talk about the coroner service it is a misnomer because even under The Coroners and Justice Act each coroner’s area is a full separate legal jurisdiction so though we have got the same law the infrastructure the courts the practices vary. The chief coroner can affect the governance and the tone of the service, but if the chief coroner issued guidance with regard to scanning, which he has done, that’s very helpful if you happen to be in Manchester or Oxford, but if you happen to be in the middle of Cornwall it’s not a lot of use because there are no scanners and there are no radiologists who have forensic training... local authorities are expected out of their existing budgets to pay for a service which is statutory. There is a misunderstanding with regard to whether it is the local authority service or the coroners’ service. Clearly it can’t be a local authority service because the local authority often appear before the coroner, the local authorities responsibility is to fund the service.’

(Coroner 4)

My observations suggest great diversity in coroners’ practices during inquests and indeed reported practices and attitudes in relation to SADS related deaths, even though all jurisdictions adhere to the same national statutory legal requirements. There are many different local procedures for when a coroner’s service is referred a case which is likely to be categorised as SADS even though the chief coroner has distributed guidelines outlining the preferable response to such a situation. The purpose of this guidance is presented as ‘saving lives arising from inherited heart conditions’ (Thornton, 2014, p. 1). This is already

beyond the legal mandate of the coroner, yet the document still highlights this as a priority when confronted with the possibility of a SADS related death. The action suggested in this guidance is limited to recommending that coroner's officers:

'should advise family members to consult their GP with a view to a possible referral for screening at a specialist NHS cardiac genetic clinic.'

(Thornton, 2014, p. 2)

This guidance was released during the process of my research and as a result many of the senior coroners I visited had not yet seen them. However, upon producing them, all coroners I conversed with reported at least conforming to the actions held within the guidance. The 'tone' of the guidance could be seen in all reports of practice but many services went far beyond advising families to visit their GPs. This practice varied from pathologists speaking to GPs directly to ensure they were appropriately informed as to the why certain families may be visiting (Cardiac Pathologist, 1), as well as speaking directly to families about what to do following the investigation (Cardiac Pathologist, 4), through to organised systems between coroners and specialist cardiology and genetics services (Coroner, 1 and 9; Cardiac Pathologist, 3; Cardiologist, 1 and 5; Specialist Nurse, 1 and 2; Clinical Geneticist, 4).

This 'jurisdictional flexibility' is not limited to professionals who captain their own jurisdictions such as coroners, but can also be seen in the practice of medical professionals. Bosk (1979) reports how clinicians often valued experience and expertise over research findings. Similarly, the use of genetic testing for ICC's in the clinical setting is rarely undertaken strictly in line with the guidelines (see Chapter 5). Moreover, medical professionals can shape their own jurisdiction. I have shown in earlier chapters that clinicians have power over the acquisition and subsequent distribution of resources. This furthers Hyeyoung Oh's (2014a) discussion of the hidden financial curriculum. She discusses the hidden financial curriculum in relation to medical training in a US hospital

and is able to show that training in financial management in medicine does not figure in the formal medical curriculum even though there is a recognition that negotiation of financial matters figure heavily in the everyday practices of clinicians. Writing specifically about the US medical setting, she states that clinicians need to find a balance between doing what is 'best' for the patient by way of follow up consultations and extra tests, which contribute to the culture of unnecessary medical waste, with providing austere care with, limiting the potential costs for patients. It is clear how this relates to the rationing of care in the NHS setting in the UK. However with reference to my findings in respect of the commissioning of ICC genetic testing in Wales (See Chapter 4), I would argue that clinicians possess a more system-level financial consciousness particularly decisions which lead to the commissioning of services or the financing of a particular test or technology at a local health service level.

This consideration is amplified further when we think about the service level thinking of the coroner, in which he/she makes practical decisions, such as whether or not to use additional testing, based upon a variety of financial and cultural issues in which a balance is struck between sustaining jurisdiction and pushing practice beyond the constraints of their jurisdiction. Much like Hyeyoung Oh (2014a) reported, much of this stretching of jurisdictional boundaries occurs behind closed doors, unofficially. For example, she reported that clinicians would often forego financial rationing decisions, ordering tests that would not be considered financially rational, on the basis of a mutually beneficial relationship with the colleague who had ordered the test. For example the colleague may offer specialist skills or services important to the clinical team such as quick access to imaging or specialist expertise in neurology. This was valued higher than financially sound decisions. This rings true to coroners' practice with regards to their informal arrangements for dealing with SADS related deaths; there is little in the way of formal agreements for dealing with SADS related deaths yet there are, in some jurisdictions, very



well established relationships which support the processing of families between the medico-legal and medical setting.

What this means for considerations of the use and usefulness of the molecular autopsy in the coroners' service is quite complicated. When we consider the distinction between resistance towards the translation of the technology compared to how useful the technology is to performing a particular function, a large overlap is apparent when we consider the jurisdiction of a profession as shaped by the professionals themselves. In such a situation, systemic limitations imposed by legal or economic constraints could be positioned as resistance to the implementation of a technology in that the professionals themselves have control over their own jurisdiction. Thus, structural limitations can be erected as a way that the coroner resists change, ultimately serving to diminish their responsibility over the decision, putting it down to structural limitations. However, it is not that simple, as these constraints do exist and coroners, in the case of the molecular autopsy, exercise their jurisdictional consciousness as a way of foreseeing the consequences of engaging in technologies which expand their jurisdiction in other important aspects of their practice.

I suspect there is a dual relation going on here in which coroners are resistant to the use of the molecular autopsy, but not for resistance sake, nor for the simple excuse that it is out of their remit (although this is a legitimate excuse in this case). Rather the reasons are more nuanced and fluid, as highlighted by a pathologist with regards to the jurisdiction of the coroner:

“The law says this, our coroner is actually being very compliant by not interpreting strictly and is sympathetic and is doing everything she possibly can. Even though you guys are frustrated because she won't go the whole hog, you have to understand she can't go the whole hog because she is responsible and accountable

and she simply doesn't have the authority or the funding or resources or whatever it is to do that.'

(Cardiac Pathologist, 3)

It is this responsibility and accountability that helps us to understand the resistance to change by coroners. It is not that they cannot mould the molecular autopsy within their jurisdiction, but their understandings of the impact this would have upon their professional legitimacy, for adopting a technology that can be considered beyond their jurisdiction.

Moreover, there is a case to be argued that the molecular autopsy technology itself is not fit for purpose (Clarke and Fujimura, 1992). It was designed by the clinical genetics community which has different priorities to the coroners' system, and constitutes a different epistemic culture (Knorr Cetina, 1999). This becomes evident when we discuss the particularities of the design and function of the technology as well as the methods of translation used thus far.

## Chapter 9: Co-construction of the Medico-Legal Molecular Autopsy

Central to discussions of the translation of the molecular autopsy is the idea that coroners are resistant to changing their priorities and practices to adopt the technology. However, this explanation has the tendency to, as Hedgecoe (2008) correctly stated, gloss over features of the technology which are undesirable to the target audience. With regards to the translation of the molecular autopsy much of this can be put down to misunderstandings of the epistemic culture in which the technology was intended to be implemented. This can be seen first and foremost within discussions that arose out of the initial publication of the term 'molecular autopsy' and the grand promissory narrative attached to it. In a 2005 series of letters to the editor published in the Mayo Clinical Proceedings, Dr. William Edwards, who was part of the first reported molecular autopsy (Ackerman et al, 1999), put forward an issue with the term molecular autopsy (Edwards, 2005). In this, he highlights a key difference between the culture of pathology and clinical genetics. In his letter, Edwards questions the special value of the molecular autopsy over other additional tests used as part of the death investigation:

“Tester et al (2005) seemed to use the term *molecular autopsy* as if this were an independent standalone procedure. In fact, the molecular autopsy represents a new tool that can be added to our existing armamentarium of tests...

Historically, pathologists have not aggrandized one component of a postmortem examination (and thereby minimized the importance of other components) by using selective terms such as... *toxicologic autopsy*. In this regard, the term *molecular autopsy* may be potentially misleading.’

(Edwards, 2005, p. 1234-1235)

In response to Edwards, Dr. Ackerman (who developed the technology and the term) is in general agreement, in that the molecular autopsy is designed to be positioned as part of the pathologist's armament. However, he also states that terminology is important and the label of the molecular autopsy has been an important part of the technology gaining traction in research and practice around the world, he contends that the term is popular and recognisable (Ackerman, 2005).

It is this aggrandization that constitutes a key epistemic difference between clinical genetics and pathology. The agenda for constructing novel entities with regards to technologies, conditions or gene mutations associated with conditions is strongly embedded within the professional identity of clinical geneticists. I have observed such instances of this discovery agenda, particularly during conference presentations, in one such occasion rather candidly a clinical geneticist stated:

'Geneticists like to make good diagnoses, identifying the rare conditions and novel mutations.'

(Notes from presentation at SADS UK Heart to Heart Conference, 2015)

This agenda is also embedded in public discourse associated with clinical genetics practice from projects such as the 100,000 Genomes Project, in which the members of the GeCIPS are practicing clinical geneticists as part of the gene discovery initiative (Genomics England, 2015a). Aggrandization simply does not seem to figure so heavily in pathological discourse, this is not due to a lack of research, many of the pathologists I have spoken to are research active. Thus the use of terms such as molecular autopsy with its connotations of special value, represents a gross misunderstanding of the professional culture of pathologists by clinical geneticists.

This disconnect between medical disciplines becomes apparent in the development of the technology itself. As the technology was developed from within the field of clinical

genetics, with input from cardiology, the shape of the technology represents the needs of this setting and is either unaware or ignores the needs of the medico-legal setting which was considered to be the point of purchase. Moreover, developments in the technology have reflected what is considered useful in the clinical setting. However, as will become clear the way in which usefulness is assessed in the clinical setting varies considerably from that which has been presented in the medico-legal setting for the purposes of the coroner.

## 9.1 Usefulness of the Molecular Autopsy in the Clinic

Within the medico-legal setting, the usefulness of the molecular autopsy was presented based upon the ability of the technology to aid in the achievement of the legal function of the coroner. With this sentiment in mind the molecular autopsy can be positioned as not very useful. When cost considerations as well as knock on effects of the molecular autopsy on other aspects of the coroner's role are considered, an argument can be advanced suggesting that the molecular autopsy could be harmful to coroners extending their jurisdiction to unreachable limits. Nowhere in my discussions with coroners or pathologists did the technical details of the molecular autopsy arise, there was no mention of the validity or utility of the technology, there was no mention of the percentage of disorders captured by this technology. There appeared to be an assumption that the molecular autopsy would provide a definitive answer if it was used. The only discussions that considered the utility of the technology were around the logistics of using genetic technology, such as issues around the procurement and storage of fresh or frozen blood or tissue, or how to send tissue to genetics laboratories.

Conversely, in the clinical setting discussions around the usefulness of the molecular autopsy focussed primarily upon technical aspects of its use. This paints a picture similar to that of Donald MacKenzie's certainty trough (1990), in that many of those in the clinical setting that I was able to speak to work very close to the production of genetic technologies in the field of ICC's, thus they have an acute understanding of the technical limitations of such technologies. In contrast, it will be rare in the medico-legal setting if a coroner or pathologist has ever ordered a genetic test at any point throughout their career. However, like Lahsen (2005) I would argue that certainty is far more multi-dimensional. It is not that clinicians or scientists are more or less uncertain than coroners or pathologists; rather it is that they are certain or uncertain about different aspects of the

technology and this is very much defined by the experience and expectations of the technology and their professional needs in relation to the technology. Clinicians on occasion, within presentations and research papers will present a more positive view of the technology in line with what MacKenzie calls 'program loyalists' (1990), which would be represented in the certainty trough diagram at the bottom of the trough, however this is a functional presentation of certainty or at least utility. It serves to promote the usefulness of the technology, as a professional group invested in its successful translation.

Clinician uncertainty is primarily technical and concerns the same uncertainties presented in relation to increasingly large gene panels and the clinical translation of whole exome or genome sequencing discussed earlier (Chapter 7). The ideal type definition of the molecular autopsy is a large gene panel test, covering a wide range of ICC's associated with sudden death. This can be seen in the two molecular autopsy panels clinically available in the UK at Oxford (33 gene) and Manchester (57 gene). In fact, the shape these molecular autopsy panels have taken has been established based on existing testing infrastructures. In creating the panels the laboratories simply combined all of their existing panels' tests for ICC's associated with sudden death, this was partly a financial driven decision:

'It's no more expensive for us to run it through [X] genes as it would be 5 using that technology, so the beauty about next gen sequencing is that it's got the same wet lab work it's got the same work floor for whatever gene panel we have got. So the actual kit includes all of those genes and what we do is filter the data we get, so if we get a long qt referral we'll filter that number of total genes down just to look at the long qt genes and likewise for Brugada and likewise for CPVT [Catecholaminergic Polymorphic Ventricular Tachycardia] but what we are doing for molecular autopsy is we are just analysing all of the genes for each of those 3 disorders all together, so actually cost implications is no greater than doing a long QT test. The interpretation however is slightly different.'

(Laboratory Geneticist)

As discussed earlier, much of the job of the lab geneticist is to filter down results to that which is relevant to the particular patient based upon phenotype presentation and family history. In many cases (when NGS is used) a large panel of genes or the whole exome is sequenced and only selective data are analysed, the rest is stored. The difference in the molecular autopsy is that there is rarely a known phenotype in the deceased so there is no information to use to filter the data, thus the analysis of a molecular autopsy is incredibly difficult. It is this aspect of the technology that clinicians are most uncertain about:

‘C. Do you see the molecular autopsy as being something that is potentially useful?

I. I don’t know actually, I mean the concern about... effectively it’s blind... I think the ‘here is a SADS case let’s do a molecular autopsy’, I suspect that is an approach that has got a fairly limited yield actually and I think the biggest problem there is your variants of uncertain significance which are going to be a substantial issue in that group. As time goes by, they only seem to be getting more of those... Obviously if you hit the mother-load and you get a classic long qt mutation or something then that is very helpful but the data I have seen so far has not suggested that there has been a particularly high yield of that kind of result from the testing.’

(Cardiologist 6)

Based on this assumption, that actually the yield of a test which ‘throws the net wide’

(Clinical Geneticist 1) in terms of gene coverage, is too low to justify and indeed to procure funding for, has had an impact on the way that the molecular autopsy is used in the clinical setting.

Although the reported uses of the molecular autopsy were very low, when I was conducting my fieldwork, a few of the centres were beginning to use the molecular



autopsy on a research basis. Due to the infancy of their research, the clinicians and scientist I spoke to were reluctant to give a precise figure regarding the yield of pathogenic variants from their tests, although all conceded that they were quite low when compared to their tests in living patients. Thus to make the test more clinically useful, with useful here equating to yielding information which can aid in the diagnosis and treatment of family members, clinicians altered their practice as well as the shape of the technology, mirroring practices in relations to the use of general genetic testing for ICC's, albeit extending this out to first degree family members. When somebody suddenly dies of channelopathy there will be little to no pathophysiological changes to the anatomy of the heart, nor is it likely that a pre-mortem ECG will have been undertaken which shows any changes consistent with a diagnosis. Yet in the clinic, as reported in chapter 5, before a genetic test will be undertaken clinicians must observe the presence of a phenotype, this becomes impossible following death. More likely than not the clinician charged with undertaking the molecular autopsy would have to do so blind. However to provide any useful information, the data yielded would need to be filtered in some way as is the case in whole exome sequencing. To do this clinicians screen first-degree relatives for a phenotype:

'Well the thing with the molecular autopsy is it works best if you define your work space, this is where it is useful, so you don't throw your net wide and hope to catch something, you need to focus the search. So here where we have done the molecular autopsy, we first clinically evaluated the parents, so say they have a long qt phenotype we can then use the long qt panel we have and look for those genes.'

(Geneticist 1)

Practically, before a clinician will order a molecular autopsy they will filter their gaze through the clinical evaluation of family members as way to make the data yielded manageable. In practice when considering the use of the molecular autopsy, it is much

more common for it to be considered in relation to the diagnosis of a surviving family member, this was the case during a cardiac genetics MDT meeting. At this meeting the use of tissue of a deceased paternal uncle of a patient was discussed as a way of attempting to identify a shared mutation between the two individuals, this triangulation serves as a way to confirm the pathogenicity of any mutations found (MDT7). The use of the molecular autopsy served exactly the same purpose as other genetic testing in this setting and was subject to the same rationing. Ultimately, the use of the tissue for this purpose was ruled out because the likelihood of a shared mutation was deemed to be unlikely, in addition to the added value of tissue of the deceased being considered a limited resource. This is only possible by viewing the technology as flexible to the needs of the clinic and indeed flexing clinical practice to fit the technology.

A leading cardiologist in the field of ICC's asked me:

'How can a dead person still be considered a patient in the NHS?'

(Cardiologist 4)

To which I could not provide an answer and still cannot<sup>32</sup>. Yet to be able to justify spending health service resources to conduct a molecular autopsy (which is what this cardiologist suggests should happen) the deceased needs to be considered a patient. It is difficult for a clinician to consider any test which has the primary benefit for anyone other than the patient. Nonetheless, clinicians (in particular centres) will endeavour where possible to conduct the molecular autopsy for family members. This goes far beyond the limitations of their professional jurisdiction, given that clinicians have the license and

---

<sup>32</sup> There are scenarios in which the dead are considered patients, at least temporarily in the health care setting. In the case of organ transplantation, the dead have very real implications for the living, although as Lock (2002) points out the distinction between the living and the dead in this case is not straight forward. The Department of Health and the General Medical Council are also in agreement that confidentiality obligations should apply to the deceased in the same way as they apply to the living (Department of Health, 2013), thus the living and the dead are given the same status with regards to confidentiality.

mandate to treat the patient not their deceased family members. In engaging with the molecular autopsy, they are exercising their jurisdictional flexibility to be able to encompass this technology within the diagnostic process of a family bereaved by a sudden death. For example, the cardiologist who asked me the above question was, at the time of the interview going through the process of trying to get the molecular autopsy funded alongside other genetic testing for ICC's all of which would come from his cardiology budget.

Based on the clinical understanding of the usefulness of the molecular autopsy, clinicians and laboratory scientists have engaged in a process of local 'co-construction' (Clarke and Fujimura, 1992), to make the technology fit better within their practices. However, there remains external issues which are difficult to correct for in the clinic or in the lab. Perhaps the main obstacle for the conduct of the molecular autopsy is access to the appropriate tissue to conduct the test on in the first place. This goes beyond the legal considerations associated with the HTA described earlier, and brings into view the many other practical and cultural issues at stake which require close working between medico-legal and clinical worlds.

## 9.2 Issues over Tissue

Much like Shostak's (2005) study of the emergence of toxicogenomics, and Kohli-Laven's et al. (2011) study of the emergence of genomic tumour signatures, the translation of the molecular autopsy into the medico-legal setting has been designed with its users in mind. In this case, that means that steps have been taken to ensure that this translation is minimally disruptive to the practices of the pathologists who are required to take the tissue.

I have shown how the technology was originally developed very much based upon what clinicians deem important (utility of the test to pick up useable mutations etc.), and designed from within the epistemic culture of the cardiac genetics clinic. Thus the molecular autopsy does not fit the practices, priorities or, as we will see, the infrastructure of the world of medico-legal pathology. The main hurdle to translation into the medico-legal setting was the format of the tissue required to undertake the genetic analysis; it is recommended that the molecular autopsy be carried out on fresh or frozen blood or tissue from the deceased (Semsarian and Ingles, 2015). This is problematic for pathologists who traditionally store tissue by formalin fixing in paraffin wax, thus any tissue stored will automatically go through the fixing process, unless the pathologist has been explicitly asked to store the tissue in a particular way.

This is an example of how clinical values associated with scientific models of utility and validity were prioritised over the ability of the test to fit in with the practices of those who would be involved in using the technology. Kohli-Laven et al. (2011) in their comparison of two trials for genomic signatures, similarly found that one of their cases *MammaPrint* required a dramatic change in pathologists' practices for them to be able to use the technology. They present this technology as disruptive to traditional pathological

practices for much the same reasons as the molecular autopsy, because it uses micro-array technology analysis that can only be conducted on fresh or frozen tissue. Kohli-Laven et al. (2011) compare this with *Oncotype*, which was developed to be minimally disruptive to the workflow of the users and yielded results which were considered clinically useful, high on the agenda of the company that developed *Oncotype* was ensuring that the platform developed would be compatible with Formalin Fixed Paraffin Embedded Tissue (FFPET). The contrast to be made between *MammaPrint* and *Oncotype* is that the former focussed on developing the 'best' technology ensuring it could achieve the highest levels of scientific validity, where as the latter compromised on some aspects of validity, such as sensitivity, to ensure the technology was useable in line with the practices and priorities of its users.

The molecular autopsy was developed more in line with the model of *MammaPrint*, in that it would require changes to pathological routines for it to be useable. Thus for the technology to be successful the job would have to change to fit the tool (Clarke and Fujimura, 1992). However, recent local developments have seen moves to develop the technology in line with the routines of pathologists, changing the tool to fit the job. In a move toward 'co-construction' (Fujimura, 1996), we can see that both the shape of the technology and the practices and routines of pathologists have been mutually attuned to each other, primarily through the work of cardiologists and geneticists working closely with pathologists, understanding how they work, and shaping the technology to fit these practices. In keeping with Timmermans (1998) discussion of Strauss's (1993) concept of trajectory, I will show how this reconfiguration of socio-technical relations between the technology and the user serves the purpose of achieving a confluence of the trajectories of pathological practice and the development of the molecular autopsy. Shostak (2005) commenting on this process of 'co-construction' in relation to the emergence of toxicogenomics as an interdisciplinary entity, gives the example of phenotypic anchoring as a way to ground new technologies within existing practices - this is described as the

technique which couples induced genomic changes with visible changes in the structure of the organism.

The main difference between this example and the molecular autopsy is the technology itself undergoes no changes. Clinicians have neither the resources nor the expertise to redefine what genetic testing is. In addition, the examples from Kohli-Laven et al. (2011) and Shostak (2005) both relate to emerging technologies or disciplines by virtue of their focus on the research setting. These studies are far more aligned with my discussion of the emergence of genetic testing for ICC's following the genetics knowledge parks initiative (Chapter 4). The case of the molecular autopsy is however quite different, in that there is no emerging technology at stake per se, instead it might be better to talk about the molecular autopsy as the translation of an existing technology into a different setting. This is important to note as this precludes any systematic change to the structure of the technology, as the genetic testing and analysis infrastructure in the health service in the UK supports a particular type of testing for ICC's, thus developing a technology which encompasses the culture of formalin fixing tissue by pathology is not an option.

Instead of developing the technology with pathologists as was the case with the development of genetic testing for ICC's with clinicians, clinicians and laboratory scientists are limited to modifying the existing technologies and infrastructure to best reflect the practices of the pathologists. As stated, the key issue impeding the use of the molecular autopsy by pathologists is the need to take and store fresh or frozen blood or tissue. This is not a simple reluctance to take tissue in a way which is not consistent with standard pathological practice, but it is an infrastructural issue; the majority of mortuaries where pathologists conduct the post-mortems do not have the facilities to store tissue at -80°C which is necessary to preserve the tissue. Thus in many cases pathologists cannot take or store frozen tissue and there is no system in place which facilitates the transportation of tissue to genetics departments which do have the freezer facilities. This is particularly

acute where the post-mortem is undertaken in a public mortuary located outside of the hospital setting.

Two modification techniques have been developed in the clinical/clinical research setting around the molecular autopsy to overcome this issue. The first is the most minimally disruptive to the working practices of the pathologists and focuses on an increased effort to improve techniques for the extraction of DNA from FFPET. The problem with DNA extraction from FFPET is linked to the effectiveness of formalin to fix tissue for histological purposes - it effectively freezes proteins in time and creates a permanent record of the structure of these proteins. The process crosslinks proteins together as a way of rigidly and permanently preserving them and as a consequence of this crosslinking it becomes incredibly difficult to extract fragments of DNA longer than a few hundred base pairs which is too short for the purposes of genetic testing using standard extraction procedures (Blow, 2007). Although FFPET is problematic, laboratories will still accept it and attempt to extract DNA, they will not reject it out of hand because of the possibility of finding enough intact DNA. A lot of work has been undertaken at one of the centres I visited to improve the process of DNA extraction from this type of tissue. A clinical geneticist admitted that early efforts to extract DNA using traditional methods associated with cardiac genetic testing were not very successful:

‘We’ve found ourselves in a number of situations where we have had families, they have had a young family member die, we have been able to access the tissue blocks and it has been very erratic as to the quality of the DNA we have been able to extract... often it has been so degraded we’ve just not been able to do any testing... You never get enough DNA out of it to get the full coverage.’

(Clinical Geneticist, 2)

As a result of this, the centre made a marked effort to improve the effectiveness of DNA extraction techniques, taking lessons from a field that has traditionally worked with this kind of tissue, cancer genetics:

‘We’ve got a very nice system because for the last 6-7 years our lab has done enormous amounts of work around extracting DNA from paraffin embedded tissue in tumour samples. We get thousands of samples through every year, for cancer. So we have built up a lot of experience around that, automated ways of doing it but we have found a new technique which gives us very high quality yields of DNA from PM. Then, do we have enough DNA of good enough quality to run on the new panel test? And we’ve done a number of those where we have and so in some we have not been able to identify a mutation but we have been able to complete the test. In others we have... actually identified... certainly in some families it has given some explanation for what has happened to their relative and then offered obviously cascade screening for other family members.’

(Clinical Geneticist, 2)

The large laboratory in this centre has the benefit of also specialising in tumour genetics and could apply this expertise to the extraction of DNA from post-mortem FFPE samples. Although it was too early to comment on yield from the molecular autopsy itself, this geneticist is confident in the DNA extraction technique, which has been shown to yield enough DNA. The effect of this on clinical-medico-legal relations is that it negates any change in practice from pathologists, they are able to take and store the tissue in the way which is useful for their purposes and thus serves as an abridgement between the two systems transforming the tissue, remaining useful to both professions. These modified DNA extraction techniques do not yield the ideal tissue for DNA extraction, but better than could be extracted before. This is the fine line that is tread when translating technologies into practice – the equilibrium between providing technically the most advanced



technology which can identify the highest amount of pathogenic variants to the highest degree of sensitivity, and providing a technology that professionals can actually use in line with their existing infrastructure. Technologies are developed to be acceptably imperfect; by the time they are translated into the clinical setting, they are out of date for very practical and economic reasons.

The second modification technique is far more co-constructed by cardiologists with the practices and priorities of pathologists in mind, again with the incentive of gaining the best result with the lowest impact upon pathologists' medico-legal practice. The main difference in this case is that it is a research based molecular autopsy as opposed to the earlier example which is clinically based. The impact of this is that there are, albeit limited, financial resources which can be used to facilitate the acquisition of the necessary tissue. This technique is technical and social in the sense that it involves the employment of a technology to preserve tissue at the same time incentivising pathologists to engage with the molecular autopsy. This repositions the use of the molecular autopsy as useful within the medico-legal investigation, or least as yielding useful information by virtue of complying with the research agenda required to conduct molecular autopsies.

The cardiologist running the study works very closely with a specialist cardiac pathologist who does a lot of coroners' work. This enables the cardiologist to reflect on the needs and limitations of this setting in his recruitment agenda. The first aspect of this is the consent procedure. This is different to medical research in living patients in that the research will be conducted on the deceased. Although medical researchers are used to using and storing human tissue, the considerations under the HTA are quite different when accessing the tissue of the deceased where the case is or has been under investigation by the coroner. The clinician running the study reflects on the complexities of straddling both the clinical and medico-legal domains:

'In general when we see patients with specific interests for research we will consent them in clinic, we will provide them with consent forms and have blood taken for genetics, and consent for retention of DNA and retention of clinical details securely in the medical school. When it comes to consent for tissue for molecular autopsy then we follow HTA regulations and we do not put research at the forefront, that research is aside potential benefit and the most important thing is to ensure that the tissue gets retained in the right medico legal province...We will initially take a HTA consent to allow retention of the tissue and we will then take that forward with clinical genetic testing with suitable consent from a relative and then also ask for research consent at that stage... When we are actually getting to grips with seeing the family... we have had the tissue sample sent to us for retention through our pathology services... then we will just contact them just for initial consent to retain. Then when the coroner's period of inquest is over that we have the tissue retained legally and acceptably.'

(Cardiologist, 4)

Even at this early stage, we can see how the cardiologist is taking very seriously the jurisdiction of the coroner and the legal limitations imposed by the HTA. He has developed a two-stage consent process from family members, the first is the HTA consent to retain the tissue, and this can happen when the coroner's investigations are still ongoing. This is to ensure that the tissue is retained legally, the research aspect of the project has no bearing at this point, consent is simply gained from the next of kin so that that the tissue can be retained for the purposes of future research. It is only following the coroner's investigation that the actual conduct of the molecular autopsy can take place which necessitates research consent, the family are effectively consented twice. It is only through knowledge of the practices involved in a coroner's investigation that this cardiologist was

able to design these consent procedures which are considerate not only to the family (who will also constitute research participants) but also to the medico-legal system.

However, to get to the stage of gaining access to the tissue, the cardiologist needs support from coroners and pathologists to enable referrals for participation and access to the tissue. Thus to gain their favour supporting recruitment into the study there needs to be some benefit to them. In discussions in relation to this study, incentives at two scales were presented; long term and immediate. I asked the cardiologist how he gets coroners to engage in the molecular autopsy in a system where they only have to establish the cause of death on the balance of probabilities, to which he discussed the changing attitudes towards SADS in the medico-legal setting instigated primarily by his pathologist colleague:

‘If we can get that accurate with diagnosis [LQTS instead of SADS] then it is reasonable to consider that coroners would consider that as a potentially important thing because there is other potential harm to the community present. So they do have this historical responsibility to determine natural and unnatural death but I think there is also a progressive education that has permitted coroners to think outside the box, and the chief coroner is very important for that point of view and indeed if you get to speak to [specialist pathologist], she’s really worked hard with the UK Cardiac Pathology Network to make this a more systematic approach. She is particularly effective in that the chief coroner has now put a directive out to all coroners that they should be taking molecular autopsy specimens.’

(Cardiologist, 4)

This first incentive is achieved through a progressive program of education in which he himself, but more notably his pathologist colleague, work to inform coroners as to the consequences of SADS and the potential of these novel genetic techniques. The effect of

this is that it has heralded institutional support from the chief coroner who now recommends the retention of tissue for the purposes of the molecular autopsy. This, as discussed earlier, runs contrary to both the HTA (in that the purpose for such retention lies beyond the remit of the coroners' investigation), as well as the coroner's jurisdiction to ascertain whether a death is natural or unnatural. This moves the coroner's role into public health terrain, since by storing the tissue they are working towards an agenda to prevent future deaths in already bereaved families<sup>33</sup>. To accommodate the needs of clinicians in preventing deaths, the chief coroner and practicing coroners across the country become flexible with the legal limitations of their jurisdiction on the assumption that by doing so they are helping to achieve a social good. Thus, the first incentive is to increase knowledge which could serve to prevent future deaths, shaped as an incentive by first engaging or 'educating' coroners as to the benefit of knowing *the* cause of death in these cases. An education regime served to align coroners with the agenda of the clinical researchers in a process of heterogeneous engineering (Law, 1989). The second direct incentive is provided by the pathologist herself, in heading a national referral centre for sudden cardiac death. What this means in practice is that she receives the whole hearts of the majority of sudden cardiac death cases in the UK and undertakes a specialist autopsy. As the centre is funded through a charity, she is able to provide this service for free (excluding the cost of getting the organ to her) and provides an expert report based on each autopsy which can be used as evidence in court. This is the main route by which the cardiologist recruits samples. Pathologists and coroners across England and Wales request a specialist autopsy from the pathologist and as part of the referral process she can then ask them to store tissue for the molecular autopsy study. Pathologists take tissue for the molecular autopsy and:

---

<sup>33</sup> Coroners do have the legal duty to prevent future deaths under regulation 28 of the Coroners' (Investigation) Rules 2013, however the mechanism for achieving this is in the format of a report to interested parties, not taking action themselves to prevent the deaths. When asked about their duty under Regulation 28 to prevent deaths associated with SADS coroners stated that such an action would be beyond the jurisdiction of such a report.

‘...send it to Dr [pathologist] as part of their package for expert cardiac pathology... That is going to be of great benefit of families in the long term, couple that with expert autopsy, which makes a big difference to families. [as well as] accurately assessing phenotype in families and then there will also be a research repository as well if families allow their relatives samples to be used for research.’

(Cardiologist 4)

This not only shows a process of incentivisation, as pathologists have access to a specialist examination by a world leading expert in cardiac pathology, it also has the added effect of placing the molecular autopsy within standard pathological practice. Sending tissue samples has been lumped together with the process of requesting a specialist autopsy, which as discussed earlier is common practice in a medico-legal investigation. The molecular autopsy is also positioned as adding value to the specialist examination. Although the findings of the molecular autopsy will take too long to be of any use to the coroner due to the nature of clinical research (i.e. it takes a long time ‘up to two years for any results’, see Chapter 6), it does serve as a way of confirming the findings at autopsy. Coupled with the phenotyping of family members which is also undertaken as part of the study, the whole process can be positioned as useful for building a picture of the cause of death. The presentation of the usefulness of the molecular autopsy, at least in this research project, actually serves to convince two groups of the benefits of participation, the coroners and pathologists, who are the gatekeepers, but also the families who need to give consent for the retention of the tissue.

However, none of these techniques to engage the coroners and pathologists overcome the infrastructural problems associated with physically storing and transporting the tissue. Through engagement with pathologists, issues pertaining to the limitations imposed by the HTA are overcome by the study gaining consent for the retention of the tissue for future research themselves. The importance of the molecular autopsy has become

embedded in the consciousness of pathologists across the country and endorsed by the chief coroner due to a regime of 'education'. Finally, the molecular autopsy has been embedded within a service already used in practice by pathologists. Although the users of the technology, pathologists, have been considered at every stage of the process, this does not overcome the fact that pathologists do not routinely have access to -80°C freezers and as such requesting that they begin freezing tissue would hugely disrupt their normal practices. This molecular autopsy study first, much like the NHS example given, initially tried to extract the DNA from the FFPE however the yield was far too low for the technology to be considered economically rational in the long term:

'The ones we are getting are coming basically from mortuaries where they don't have any pathways set up to, they are not being done at tertiary centres with suitable freezers or suitable media for storage, or the resources to then transfer them to a genetics service. So the main barriers I see to this being adopted across the NHS is the pathway between the coroners, pathologist and mortuary and the NHS. Because I think we are ready to receive samples but it is more of a case that they are not retained at autopsy... The awareness is there but there just aren't the facilities there to do it. What we are using the university infrastructure for is actually to address the problem of retention at the mortuary, at pathology at the autopsy providing them with the facilities to do that. Usually by taking small sample of spleen and placing it in a solution at room temperature (RNAlater) which allows for the nucleic acid storage at room temperature for a period of time. This allows for the sample to be sent along with the heart for expert autopsy as a package rather than having to be frozen or sent elsewhere, or put in a -80°C fridge.'

(Cardiologist 4)

The method for overcoming the obstacle of tissue storage furthers the connection between the molecular autopsy and the specialist autopsy in that the RNAlater enables a piece of

fresh spleen to be transported within the same package as the heart, which the pathologists will have already fixed in formalin. This solution was only made visible through close working with pathologists and a good understanding of the practices and indeed limitations of the medico-legal setting. This close working enabled the discussion to go beyond the problem that pathologists will only 'send us fixed tissue' because culturally and historically that is how they do it, to asking why they cannot provide frozen tissue. By engaging with pathologists, this study was able to establish a solution to overcome the structural and cultural impediments to the use of the molecular autopsy. In this way the RNAlater has a dramatic impact on the socio-technical relations between the pathologist and the molecular autopsy; by stripping away the structural impediments to engaging with the technology and locating it within the standard day-to-day procedures of the pathologist, the molecular autopsy becomes accessible. However, this was not simply a technical intervention, it is a process of co-construction. The practices and attitudes of the medico-legal setting in relation to SADS were developed alongside the technical modifications to enable the molecular autopsy in this setting.

This example differs from the approach taken by the NHS, in that there was no attempt presented here to inform or develop the practices of the clinic and the medico-legal setting to absorb the molecular autopsy into practice. Pathological practice was seen as rigid and unchanging and thus the modifications, i.e. development in FFPE DNA extraction techniques came solely from the clinical setting. Although the second case is more disruptive to the pathological practice, it shows an attempt to establish a confluence of trajectories between the medico-legal and the clinical setting, connecting understandings and approaches to the problem of SADS. This is positioned by the cardiologist as important for the sustained success of the molecular autopsy when it comes into clinical practice.

The role of the molecular autopsy is to connect life and death; it is to take lessons from the dead to protect the living<sup>34</sup>. However, information pertaining to death is not neutral, it is constructed within the medico-legal system of death investigation, and as such it is shaped by the professional practises, priorities, norms and indeed jurisdictional limitations of this setting. Practitioners in this setting 'broker' (Timmermans, 2005) death into acceptable categories informed by the social need to explain and understand death. They possess the legal mandate to investigate and consign meaning to violent, suspicious or unexpected deaths or deaths where there is no known cause. However, they do not do this in a vacuum. Although coroners have the power to define what it means to die a natural or unnatural death, the means by which they come to these definitions are bounded by the limitations of the coroner's jurisdiction. None the less the knowledge and information constructed by coroners has profound impacts on the way we understand death, as a result the death we know about is legal death. This information also has very real implications for the health service. As Foucault famously stated:

'It is at death that disease and life speak their truth'

(Foucault, 1973, p. 145)

It is only at death that some information becomes available, most obviously mortality statistics, and these have an impact not only on our understanding of epidemiological trends but also on the commissioning of health services. Of course, as has been well rehearsed by now (Atkinson, 1978; Douglas, 1967; Prior, 1985; Prior, 1989; Bloor, 1991; Pescosolido and Mendelsohn, 1986) this information is considered to be an imperfect, socially constructed, representation of the demography of death.

SADS serves as a good example of how a legal definition has influenced medical practice. As discussed earlier SADS is a legal and social construct, devised as a way of avoiding the

---

<sup>34</sup> This is a paraphrase of the Ontario coroner's motto: 'To speak for the dead to protect the living' (Dalton, 1994).



use of unascertained. None the less, the figures provided for the amount of deaths categorised as SADS per year is written about in the media<sup>35</sup> and in research papers reporting the magnitude of SADS in the UK (Papardakis et al 2009). These of course have knock on effects for the commissioning of ICC's services which were rationalised based upon the need to prevent deaths caused by SADS. For example Chapter 8 of the National Service Framework for coronary heart disease estimated that there were around 400 sudden cardiac deaths in the UK per year where no cause could be found (Department of Health, 2005) and this has been shown earlier to have had a dramatic impact on the shape that ICC services have today.

---

<sup>35</sup> Every year in late October early November, there is an increase in the amount of media coverage reporting changing trends in mortality, such as an increase in dementia or decrease in heart disease. This coincides with the release of office of national statistics annual mortality report (Series DR). However, as Prior (1989) noted these figures tell us more about changing registration practices than they do the magnitude of any category of death. For further discussion on this see Prior's commentary on the impact of changing versions of the International Classification of Diseases on the amount of deaths related to heart disease (Prior, 1989).

## Chapter 10: The 'Magnitude' of Deaths Categorised as SADS

When death statistics are unpicked and positioned within the social and political space in which SADS deaths are registered it becomes apparent that the figures held by ONS tell us more about changing attitudes towards SADS by the medico-legal system than they do about the amount of SADS in the UK. To show this I have taken a published report of the magnitude of SADS in the UK (Papardakis et al, 2009) and replicated their methodology for what they refer to as Class A1 sudden deaths, which are the autopsy negative sudden deaths commonly referred to as SADS. They analysed mortality data from 2002-2005 focussing on ICD-10 categories associated with sudden cardiac death, for Class A1 sudden deaths they used codes:

R96: other sudden death, cause unknown

I49.9: cardiac arrhythmia, unspecified

I46.1: sudden cardiac death, so described

I45.6: pre-excitation syndrome (Wolff-Parkinson-White Syndrome (WPW))

They also limited their focus to the ages 1-34. Although I cannot attest to the rationale of the authors in selecting these categories to represent autopsy negative sudden cardiac deaths, I did confirm that these were the commonly used categories by coroners when registering such a death. This was confirmed by a representative from the mortality analysis team at the office for national statistics. She accessed the death certificates for deaths registered in the above categories and confirmed that these are generally the categories used by coroners<sup>36</sup> when registering SADS type deaths.

I continued the series conducted by Papardakis et al. (2009) up to 2014. It is important to note that this is not designed to say anything about the magnitude of SADS in the UK but

---

<sup>36</sup> She also confirmed that every SADS death in the UK (every death covered by the concerned ICD-10 categories) is registered by a coroner.

simply that there is a visible trend in the data presented. Figure 5 summarises Papardakis's et al. (2009) findings and presents the continuation of the study up until the current iteration of the ONS mortality data:

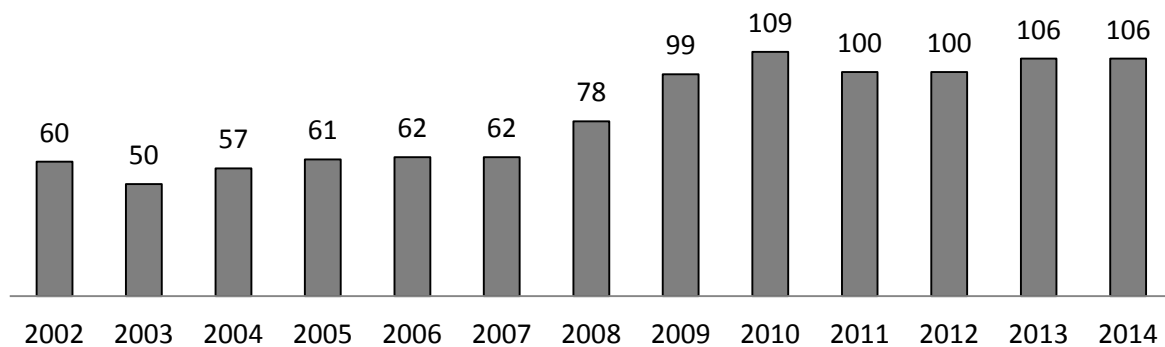

Figure 5. Number of Deaths per Year Associated with SADS.

This however presents a different magnitude of SADS than that which was presented to an MP from the ONS with regards to the amount of 'Sudden Arrhythmic Cardiac Death Syndrome' for which the annual figures were: 251 in 2009; 268 in 2010; 277 in 2011; 293 in 2012; and 322 in 2013 (Appendix 1). This reveals a huge discrepancy between these figures, yet both are presented as the amount of SADS in the UK. Returning to figure 5, this graph shows that there has been a dramatic increase in the annual amount of deaths registered as SADS in the UK over the last 12 years (60-106). However, there has not been a SADS epidemic or any other medically defined change which could explain this increase in the amount of SADS in the UK. There has been a dramatic change in attitudes towards SADS in the medico-legal domain however. The UK Cardiac Pathology Network (UKCPN) was established in 2006, which gathered the expertise of all cardiac pathologists in the UK and began to produce reports aimed at pathologists in relation to the conduct of the cardiac autopsy as well as other guidance aimed at coroners' recognition of SADS. In 2008, the CRY centre for cardiac pathology was established and began offering specialist cardiac

examination free of charge. There have been a number of other developments which mark a more general interest in SADS such as the publication of Chapter 8 in 2005, or the national service review of ICC services by the PHG foundation in 2009, both of which had sections specifically aimed at engaging with coroners. The impact of these incentives can be seen by the actions of the chief coroner, last year publishing guidance on how to manage SADS cases and this year (2016) publicly advocating the retention and storage of tissue for the molecular autopsy.

In many respects, Michael Davies has achieved his agenda in establishing the category of sudden unexpected death syndrome (1994); creating this category has resulted in an increased interest and investment in SADS related deaths. SADS then becomes a performative category used to yield particular actions, serving more than, as Timmermans (2006) claims in relation to SIDS, a 'stopgap' designed to protect professional jurisdiction by covering up the boundaries of their jurisdiction. Instead, using SADS serves as an admission of the limits of their jurisdiction passing responsibility to further explaining SADS to another professional group, most notably medicine and biomedical science. Although, as has been discussed throughout this thesis, this agenda has been widely adopted by cardiologists and geneticists in the clinical and research field, there has been little consideration of the translation of SADS between the medico-legal discourse in which it was devised and the medical discourse in which the research is conducted and families are treated.

Connecting life and death draws together two separate professional domains, defined by separate languages and practices and power relations. This can of course lead to inter-professional friction based different disciplinary expectations<sup>37</sup>. For example, it is common for those in the medical domain to complain about the information held on post-mortem

---

<sup>37</sup> For a related discussion see Edwards et al. (2011) on *Science Friction* and the problems associated with interdisciplinary projects in science and the ways this friction is overcome through the effective use of metadata.

reports, often citing that it is incomplete or otherwise not very useful for the medical purpose of helping to diagnose living family members. However, this assumption fails to consider the practices that constitute the medico-legal post-mortem and the limited legal function of it in requiring specific legally admissible pieces of information presented in a particular way.

Much the same can be said about medicalized assumptions of mortality data, which is assumed to represent a certain type of evidence by those who use it, such as those measuring the magnitude of certain categories of death (see Papardakis et al 2009). However, in reality these data represents legally admissible causes of death, because in medical terms nobody can die of SADS:

‘We don’t have anything called SADS... it suits [constitutes] a bit of a bucket term really.’

(Cardiologist, 6)

Yet this information remains used within medicine without reflection upon the origin of the term as a rhetorical legal construct, which has very different interests to the medical field.

It is these differing interests between the medico-legal and medical domain that have the most profound implications for the translation of the molecular autopsy. It is not because these differing interests are incommensurable, but there has been limited consideration of these differing interests in the development of the technology, which primarily represents the interests of the clinical setting in which the technology was developed.

### Part III: Making SADS

The previous Parts have discussed the political and socio-economic spaces that inform the practices of two distinct epistemic cultures when confronted with SADS. However, as discussed in the previous chapter: 'We don't have anything called SADS' (Cardiologist, 6). Whilst professional groups have attributed meaning to SADS, the meanings attributed are different reflecting both the practices and priorities of the professional group concerned as well as the circumstances by which the group came to know about SADS. This Part, in keeping with many of the concerns of Annemarie Mol in her 2002 *The Body Multiple*, aims to discuss and distinguish the multiplicities of understandings of SADS as embedded within the practices of the professionals who enact it. However, unlike Mol I am not only interested in "the practitioner's hands" (Mol, 2002, p. 152) - I will also consider the embodied contemplation (as opposed to disembodied contemplation avoided by Mol) - how practitioners' articulate thoughts about their practices in relation to the object, in this case SADS, and the effect this has on their practices as well as inter-professional activities.

Embodied contemplation also extends Mol's epistemology in that it enables reflections upon internal and external influences on conceptions of and practices in relation to SADS, and thus subsequent accounts presented within interactions. This positions SADS as a 'Boundary Object' (Star and Bowker 1999; Star and Greisemer, 1989), a conception that is important, not only in that it embodies a sense of interpretive flexibility in perceptions of a particular object, but also that by employing this idea we can talk about how groups work together without consensus of what they are working on or towards. This differs significantly from the multiplicities presented by Mol, in that she notes how groups work towards a 'co-ordination into a singularity' (Mol, 2002, p. 70) in inter-professional practice, as opposed to the heterogeneity which persists in Star's (2010) concept

(Boundary Object). I will take something of a middle ground in which practical, political and socio-economic considerations affect the perception of the central object, yet during inter-professional interactions these objects can be presented as the same, or at least complimentary, which provides a rhetorical presentation of confluence. This is somewhat different to the shared language trading zone put forward by Galison (1997) in that there is not an agreed upon meaning or language within the interaction, instead each party brings with them assumptions and presuppositions, which structure the accounts given.

The consequences of understanding interactions in this way are far reaching. For example, consider Chapter 9, in which the translation of the molecular autopsy into the medico-legal setting is discussed. One of the major points of contention was the appearance of a lack of attention given to the needs and function of the death investigation; thus the structure of the technology and the means by which the clinical space attempted to translate the molecular autopsy was not done in a way as to be useful within the coronial investigation. It was only when those invested in this translation began working closely with coroners and pathologists that the translation became more effective. This is not to claim that there was an initial lack of attention given to the needs of the medico-legal setting, rather I am arguing that clinicians' understanding of those needs were limited to assumptions, limited interactions and second-hand accounts. This resonates with Ribiero's 'physical contiguity' (2013) in which he places high value on physical closeness for cohesive collaborative practices. Although physical closeness will not be dwelled on here, the amount of contact and the type of contact groups have with each other will be considered as important in understanding both the practices and as a consequence the meanings and interpretations of objects presented by disparate professional groups.

With this in mind, this Part attempts to draw upon the previous two parts of this thesis in discussing how political, economic and disciplinary relations impact practices, or at least accounts of practice, not only during interviews but also during inter-professional

interactions. In doing this I aim to unravel simplistic explanations of the medicalization (Conrad, 1975) or Geneticization (Lippman, 1991) of SADS, instead offering a more nuanced approach in which, what SADS is, as a medical or legal entity, is multiply understood by practitioners and multiply mobilised to serve particular functions.

The first chapter in this part will present the different practices which inform how SADS is made from different disciplinary perspectives. This will build upon earlier sections by situating political, economic, disciplinary and jurisdictional concerns concretely in practice and accounts of practice. The second chapter of this part will examine how these different constructions of what SADS is as well as accounts of disciplinary professional practices more generally, impact inter-professional communication and collaboration.



## Chapter 11: What Is It?

'What is it?' sessions are common at pathology conferences and are similar in format to the case study sessions at clinical genetics conferences. Both serve the function of placing a particular set of symptoms into a disciplinarily recognised medical category, either with the aim to aid in the diagnosis and treatment of a patient or sometimes presenting the audience a case of note or interest based upon a particularly unusual set of symptoms or characteristics. What is of note when comparing these sessions at international pathology conferences and genetics conferences is the way in which the conditions are seen in the patients, living or dead, as well as the modes of categorisation into accepted disease entities.

Genetics conferences favour the presentation initially of dysmorphology, in which the audience, made up of practicing clinicians from the field of genetics or closely allied disciplines, scrutinise particular physical features of a patient, focusing on the positioning and shape of facial features and digits on the hands and feet. Often, before a diagnosis is confirmed there will be comments, reflecting observations by Latimer (2013) that features 'look dysmorphic', in many cases before the problematic aspects of the phenotype are presented. The cases I was able to observe were primarily cardiac related, many of which associated with life limiting or life threatening symptoms, such as the risk of aortic dissection associated with Marfan syndrome for example. The means by which these issues emerged was through close collaboration with colleagues in the field of cardiology, which is common in clinical cardiac genetics. Symptoms, if present in the patient were presented via cardiological diagnostic technologies such as the ECG or the cardiac echo. Mirroring the clinical investigation of cardiac genetic conditions presented earlier, it is only after the examination of phenotypical features that the presentation of any genetic factors are made. In the majority of cases the suspected genetic condition is also suspected

to be hereditary (excluding de novo mutations), as such a family pedigree or photographs of the patients/probands family are also presented. It is only after all this that the results of any genetic tests are unveiled. In the case that the presenters are presenting a case of interest for which they have a diagnosis this often serves as a conclusion of the case study with the gene mutation serving to confirm a diagnosis.

At cardiac pathology conferences, although the form and purpose of the presentation at the 'what is it?' session remains the same, the content and focus is drastically different. In the introductory section of the case study, a brief history of how the patient came to the attention of the pathology service as well as any symptoms of note is presented. However whereas in the genetics presentation this takes up a lot of the case study, it is usual for this to only take up one or two slide of the pathologist's presentation. The rest of the case study focuses solely on the presentation of various histopathology slides or other photographs of pathology if there are visible morphological features. During the presentation of each slide the presenter goes into great detail with regards to the type of staining used on the tissue, the level of magnification and of course the area of the heart that the tissue was taken from. The conclusion of the presentation relies on physically seeing the pathological changes on the slide and recognising these changes in a consistent manner according to the disciplinary consensus.

These examples highlight how different clinical disciplines present a condition or illness, and this is undertaken through the deployment of the tools and measurement techniques appropriate for their discipline. The comparison of clinical genetics and pathology is particularly interesting as we can see how each can come to the same conclusion by very different means and this can have an impact on the way that each of the fields perceive the conditions. Disease is made visible for pathologists under the microscope (Mol, 2002), without this tool pathologists could not see the extent of fibro-fatty replacement associated with Arrhythmogenic Right Ventricular Cardiomyopathy (ARVC) or the

muscular disarray associated with Hypertrophic Cardiomyopathy (HCM). Equally clinical geneticists and cardiologists are only able to see ARVC through the presentation of epsilon waves on the ECG, or through the use of an MRI to pick up subtle anatomical changes and finally through the targeted pedigree analysis for other confirmed diagnoses of ARVC in the family (te Riele, et al 2014). The right tools for the job may not solely represent the usefulness of a tool or technology to serve the denoted purpose, the ECG and the analysis of histopathology can give an appropriately accurate diagnosis of ARVC. Instead what is at stake is more about what the professional standards are for making a diagnosis and what is pragmatically achievable under the organisational constraints of the service provided.

### 11.1 Different and Differential Standards of Diagnoses

The primary practical difference between cardiac pathology and clinical cardiac genetics is the presence of a patient in the diagnostic process. Although all pathologists figure the patient in the diagnostic narrative and function<sup>38</sup>, it is common when asked about why they decided to become a pathologist to (in jest) blame their poor bedside manner:

‘C. what made you decide to become a pathologist?’

I. I found it was interesting and like so many pathologists I wasn’t particularly well trained at dealing with patients and was quite happy to not have any contact with patients, it was also a very practical aspect I like doing things with my hands, dissection and anatomy.’

(Cardiac Pathologist 1)

The presence of a functioning human body or as is more the case in genetics the presence of multiple functioning bodies has a dramatic impact on how a body is seen, as well as what can be seen in the body. The pathologist is limited to a static shot in time thus the tools employed must be able to capture this shot to varying degrees of sensitivity. He/she does not have the luxury of a beating heart to observe in action, nor can he/she ask the patient about their symptoms. These are important factors when coming to a diagnosis of a cardiac condition in which the major impact is on the conduction of the heart, which is invisible as soon as the heart stops functioning. Equally, it would be very informative for clinicians to be able to examine the anatomy and pathology of the heart of their patients, however due to the difficulties associated with conducting a cardiac autopsy on a living heart this is not an option; as such, clinicians rely on technologically produced representations of the heart. Not only is the technologically mediated way in which these

---

<sup>38</sup> All pathologists I interviewed were clinical pathologists and did coroners’ work in addition to their NHS contract. Their primary role was to examine surgical heart biopsies and explanted hearts.

groups understand and explain what it is that they see 'disciplined', based upon their particular jurisdiction (i.e. pathologists have the licence and mandate to examine the pathology of tissue), but these ways of seeing are culturally reproduced during training. Although both pathologists and clinical geneticists will experience the same undergraduate medical curriculum, following specialisation they will only be trained in certain technologies and techniques and will thus only be able to see and construct diagnoses based upon these disciplinary constraints.

This becomes further complicated when this disciplinary gaze is extended beyond the domain of the medical to the medico-legal setting of the coroner. The tool by which the coroner sees SADS or any other medical cause of death is through the development of a narrative which relies heavily upon a post-mortem report from their pathologist. This is very different from saying the tools of diagnosis are the same as the pathologists, because the mode of dissection of the heart, the particular stains used to see muscular disarray associated with HCM is not pertinent to the coroner in making his/her conclusion. It is the narrative held within the report that serves as the tool in this setting. During the entirety of my field work I did not encounter any coroner who questioned the methods employed by the pathologist. Nevertheless, care was taken by pathologists to ensure that tissue was taken only for the purposes of the coroner. Only pertinent histopathology or toxicology was undertaken based upon their understanding of the coroner's duty, this was not based on any disciplining from the coroner. This appears to be a relationship of trust. The coroner implicitly trusts the pathologists they work most closely with. There may be truth to this, however more often this is framed in terms of coroners admitting limited expertise to claim authority over pathologists practice, and thus they lack the ability to appraise pathologists' work.

## 11.2 Who Is It?

The disciplinary differences presented above in terms of practices and jurisdictional boundaries not only affect the practices conducted on the central object with the function of arriving at a diagnosis/conclusion, but structure the perception of the central object itself. In this case, the central object can be broadly categorised as a somehow pathological human body, however beyond this, disciplinary norms and practices inform how this body is perceived and subsequently acted upon.

Within the medico-legal setting there is no therapeutic agenda. The coroner is simply mandated to place the death into a legally and socially accepted category of death. In practice the coroner will very rarely see the body that they are investigating, thus who is investigated for the coroner is reduced to a set of documents. These can include statements from witnesses or family members, medical history, police reports and the post-mortem report. This is clearly visible in the performance of the coroner's inquest in which such documentary evidence is compiled as a way to see what happened leading up to the death, this constitutes the evidence that is heard in court. The Coroner commonly refers to 'the case' as the focus of the investigation. This is carried through to pathologists when doing coroner's work. The key difference between the case for the coroner and the pathologist is the physical presence of a body as a whole or in part in the case of specialist examinations. Although pathologists do not dehumanize the body, it is situated as a static object with their intervention serving to categorise, within their disciplinary standards, what is abnormal and what should be reported as contributing to causing the body to be in the state that it is. There is no function to the body and no intervention that can be done to make things any better or worse: 'The worst has already happened' (Coroner, 4). This perception is significantly different to the clinical setting.

The significant shift in approach to the body in the clinical setting is the presence of a functioning human body. This creates a sense of fragility and responsibility, which is considerably different to that in the medico-legal setting. The interventions of the clinic can have a direct impact on the future functioning of the body. This can be seen in the care taken by cardiologists in the UK when deciding whether to perform invasive interventions on their patients. One of the more invasive procedures conducted in the field of ICC's (other than transplantation) is the implantation of the Implantable Cardioverter-Defibrillator (ICD). This device is implanted to reduce the risk of sudden death due to ventricular fibrillation, which is a common symptom in many ICC's, and the primary cause of death in SADS cases. The device is implanted under the collar-bone and the defibrillation leads are inserted directly into the right ventricle of the heart.

Appropriateness to implant an ICD is appraised in relation to community guidelines. This is not to say that guidelines determine the decisions of clinicians in relation to implanting ICD's. Instead the guidance serves as a stratified way of justifying the decision to implant or not to implant the device, based upon strength of scientific evidence and the risk to benefit ratio for the patient:

'So if you have class one recommendation, it's a strong indication, its backed by strong evidence, and then 2a has got one or two randomised trials perhaps and then 2b is dodgy but you can do it because there's a bit of evidence about, a bit of expert opinion, and then there's class 3 which is you shouldn't do it.'

(Cardiologist 1)

The guidance the cardiologist is referring to is the international expert consensus statement on the diagnosis and management of patients with inherited primary arrhythmia syndromes (Priori et al, 2013). The information held within the consensus statement along with experience in relation to the potential complications associated with the surgery as well as the characteristics of the patient factor into whether the cardiologist

recommends the implantation of an ICD. This is factored into the guidance by offering a sliding scale rather than binary categories. This reflects the picture of guidelines presented by Timmermans and Berg (2003), who discuss a move towards evidence-based practice guidelines, however within these guidelines there is a maintained emphasis on access to specialists when interpreting and applying the guidance to individual patients.

The ICD is an interesting example of an intervention, in that it is not applied in isolation and it does not prevent ventricular fibrillation from occurring (excluding those with pacing functions) - it serves to correct the arrhythmia if it were to occur. All patients with an ICD that was implanted following an 'aborted sudden death', are also prescribed pacing medications, which serve to prevent ventricular fibrillation from occurring. Of the people I have met with ICD's only those who misused their primary anti-arrhythmia medication, or acted against advice (i.e. engaged in high intensity physical activity) have received a shock from the device. The ICD is a second tier intervention, used in patients with a high risk of sudden death. It also comes with serious potential complications, the most common of which is inappropriate shocks. Thus, the decision to place an ICD into a patient is weighed up based upon the therapeutic benefit to the patient, the impact the intervention will have upon the day to day life, as well as the risks associated with the intervention. As the therapeutic benefit equates to preventing sudden death it is only implanted in patients at a perceived high risk of sudden death. It is this rationalisation criteria that stops clinicians from putting ICD's in all of their Arrhythmia and Cardiomyopathy patients. There is a potential therapeutic benefit for most patients in this group as there is a risk of sudden death in this patient group, however this intervention is not applied across all patients, based upon the impact it has upon the patient over and above the rationalised therapeutic benefit. This distinguishes the cardiology clinical setting from the medico-legal setting in relation to approaches to the body. In this setting any intervention or action towards the body has implications for the person. The clinician not only has the responsibility to



diagnose and treat the patient but also to protect them from harm, to ensure the continued functioning of the body.

The shift in perspective is no less between clinical cardiology and genetics in terms of their approach to the body. Although both of these disciplines are closely aligned in their practices in respect of ICC's, their approach to patients varies. Cardiologists focus their practice in relation to *the patient* as an individual, the risks and benefits are rationalised in relation to the impact they will have upon the patient's life. In clinical cardiac genetics, the focus is rarely focussed on the individual patient. The focus of genetics case studies will commonly be referred to as the 'proband' as opposed to the patient, this simply refers to the start of a genetics study or index case, which is then extended to other potentially affected family members. In none of the 8 Cardiac Genetics MDT's I was able to observe, which discussed between 10-20 patients each, was an individual patient discussed. In many cases, the presentation of the patient in the MDT was used as a way to discuss a different individual in the family. During a Cardiomyopathy MDT a patient was introduced by the Cardiologist as an elderly gentleman with clear HCM (left ventricle 26mm thick). The cardiologist immediately commented that although he listed this patient he did not want to talk about him. His concern instead was his daughter and his grandson. His grandson is being treated by the paediatric cardiologist who also attends the MDT. The concern for the cardiologist is actually the daughter as they know very little about her, she is not a patient. The cardiologist uses the MDT to refer the grandson for genetic testing, as a way of enrolling the daughter in the clinical system by means of cascade screening 'from the bottom up'. Attempts had been made to enrol her via her father but these were unsuccessful. I present this case as it shows how the line between who is a patient and who is not a patient can become blurred in clinical genetics. Officially, a person only becomes a patient following referral (Clinical Geneticist 4), however clinicians in this setting actively seek referral of family members of patients they identify as being at

particular risk. Thus, clinicians in the field of cardiac genetics have a sense of extended responsibility beyond the individual patient through to the extended family pedigree.

Indeed it was consistently reported by clinicians, nurses and genetics counsellors that where possible whole families would be seen in the same clinical appointment, with some reporting up to 8 family members in the same consultation. The clinical genetics model calls for a re-imagining of the traditional physician-patient dynamic (Resnik, 2003), in which the clinician has a responsibility towards the individual patient's well-being, to a dynamic in which information yielded for one patient can have consequences for others in their family. This broader conception of clinical focus brings with it problems associated with data sharing. Much of this stems from traditional ideologies held within the medical institution in which doctor-patient confidentiality is legally mandated. In recent years much concern has arisen in the practice of clinical genetics over the issue of (non)disclosure (Arribas-Ayllon, Sarangi and Clarke, 2012; Resnik, 2003). This issue has become incredibly important in the field of ICC's in which family members of the individual patient may be at risk of sudden death if information is not disclosed to them (Vavolizza et al, 2015). Nonetheless, all genetics health professionals in this study reported to keep strictly to the ethic of non-disclosure. Instead, these professionals relied upon the individual patients to disclose genetic information to their family members. This reflects staff practices in relation to disclosure reported in other studies (Forrest et al, 2003), although it is reported that this relationship is problematic, in that it places responsibility for disclosure outside of the clinicians control, thus there is little certainty that the information is shared effectively (Lucassen and Parker, 2016; Dheensa et al 2016). Clinical genetics health professionals in this study recognised this possibility and took particular care to ensure that all concerned family members received the appropriate information, whilst maintaining confidentiality. The primary method for achieving this was to draft a letter with the details of the clinic, containing the clinically pertinent information, which was given to the patient to distribute to other family members.

Although this ensures that the appropriate information is given, it is only effective if the information is shared. While in this study, few participants reported problems associated with family members not disclosing, there are often practical and social limitations to the effectiveness of this family-centred approach.

Family dynamics is reported to be difficult to manage by both clinical geneticists and genetic counsellors. The ways in which health care professionals manage difficult dynamics is referred to as 'handling families' (Genetic Counsellor 3), this is a process of getting the members of the family on the 'same page' as the clinical team, by ensuring they are not going to be getting information they were not expecting or that had not been adequately explained beforehand. Only in one case did a genetic counsellor report 'cold calling' an individual giving them information they were not expecting to receive:

'I try my hardest not to cold call, but there is the odd occasion where I will have to write to the GP of a relative that might be at risk. For example if somebody has been privately fostered in the family or if someone has been adopted out of the family or if the parents have broken up of the deceased. I had some people in clinic a couple of weeks ago who were privately fostered in the family and that was quite distressing for them because their dad had died suddenly and they were being fostered and their mum had nothing to do with them so they hadn't known really about this history of this heart condition on dads side.'

(Genetic Counsellor 1)

I have not referred to this as disclosure of information, as the information pertaining to their situation comes from a deceased individual and thus is not subject to the same ethical quandary, although perhaps different ethical considerations should be articulated. Care is also taken to respect less than amicable family dynamics, ensuring that information is not shared across family rifts:

'Well firstly I draw out a separate family tree and start with what that other person knows, that's what makes sense to do; 'so you tell me what you know and I'm not really going to tell you what I know until I know what you know', sort of thing. Then it usually works out. That's sometimes where people get upset because they feel they haven't been given as much information as somebody else or they haven't been told at the same time or you know that sort of thing.'

(Genetic Counsellor 1)

This is presented not as a formal part of the role of the genetic counsellor but as an iterative process of getting to know the families they serve. There is a sense in which families 'let you know' (Genetic Counsellor 3) when there are rifts, yet caution is taken when dealing with extended families within the clinical setting. The family are positioned not as a unit in which pathology is found and which treatment can be passively applied, but as a dynamic, reflective group with whom the practitioners engage with. Perceiving the family in such a way extends Armstrong's (2011) re-positioning of the patient as active in the diagnostic process through to the whole extended family. In doing so, this raises the issue of the position of the family as a group of patients in the diagnostic process.

Armstrong (2011) and Jutel and Nettleton (2011) factor the patient at the beginning of the clinical process, in that generally the patient brings themselves to the attention of the medical practitioner with a set of symptoms to gain a diagnosis. However, in the clinical genetics scenario many family members do not have symptoms nor did they seek medical advice; they are enrolled into the system, and as such a primary aspect of 'handling families' is not only to let them know what to expect but also to give them the opportunity to air their expectations.

By focussing the clinical gaze on the family pedigree, clinical genetics health professionals are not viewing patients as separate from each other. Information gathered from one patient is considered to have potential direct consequences for another patient in the

same family. Thus, it was often the case in the cardiac genetic MDT that genetic testing would be conducted on an individual in which the primary implications were for another family member (See Chapter 5). Moreover, by considering the pedigree as the focus of the clinical gaze information is not limited to present family members or only family members within the clinical system. Information from dead family members is often considered relevant in the cardiac genetics clinic. It is standard practice to access the post-mortem report of an individual who had suddenly died when a family member is seen clinically, as the information is considered integral to understanding the risks to the patient and other family members. This is further extended into the future as genetic consultations often invoke issues associated with reproduction, and thus the impact of genetic information on future generations of the same family are also considered.

The case, the patient and the pedigree can all be considered to represent the same central object to a greater or lesser extent. However how they are mobilised in practice from different epistemic cultures dramatically re-figures the pathological body in such a way that one would not be recognised as the other. The body is transformed by the technologies and techniques used to see it in ways to ensure it fits with the gaze of the professional who is looking at it.

### 11.3 *'Forme Fruste'*

Although nomenclature can be viewed in terms of disciplinary preferences, it can in some cases represent more significant differences in the understandings and experience the disciplines have to the object they are describing/defining. All professional groups I researched had very different standards of practice and placed different value on some forms of information over others, in doing so the constructions of the object, in this case the cardiac condition can become very different over time.

This section will take the specific example of ARVC/D (Arrhythmogenic Right Ventricular Cardiomyopathy/Dysplasia) and will focus on how specific practices and standards across medical disciplines produce divergent understandings of what the condition is.

There is consensus across medical disciplines that ARVC is a serious cardiomyopathy with the potential symptom of causing fatal ventricular fibrillation due to changes in the ventricle walls. However, the tools used to see ARVC within disciplines as well as the disciplinary standards that prescribe which techniques are appropriate to use create very different pictures of ARVC. There is a strong history of research in Science and Technology Studies and Medical Sociology on the process of standardization (Lampland and Star, 2009; Timmermans and Berg, 2003), which denote the process of standardization as explicitly political. This section will draw upon this literature in exploring how standards and the value attributed to certain standards of practice shape understandings and approaches of medical professionals towards the disease entities they are diagnosing and treating.

ARVC/D came to my attention as a particularly interesting case, in that what is considered a normal presentation of the condition in one discipline would be considered atypical or *'forme fruste'* (Cardiac Pathologist 3) in another. This has become so entrenched within

the discourse of these groups that the very terminology for describing the condition has been adapted by each group. Pathologists primarily see ARVC when conducting an autopsy of a heart (explanted or during a medico-legal post-mortem). Within this process if ARVC (or any other cardiac abnormality) is suspected it is standard practice to conduct an in depth examination of the heart. Guidance of how to perform this procedure has been outlined by leading cardiac pathologists in the UK (Royal College of Pathologists, 2015). These standards dictate that the whole heart be examined in great detail. Thus a pathologist will not only be able to see if fibro-fatty penetration, which is the telltale sign of ARVC, is visible in the right ventricle, but will also be able to see if this same pathology is visible elsewhere in the heart. This has led pathologists to use the acronym ACM (Arrhythmogenic Cardiomyopathy) in conversation, because they see the fibro-fatty penetration throughout both ventricles of the heart:

‘Well it did it used to be called arrhythmogenic right ventricular cardiomyopathy then they changed it to arrhythmogenic cardiomyopathy because it’s part of a spectrum. Usually it involves all or part of the right ventricle, but it can involve the right and the left, and it can involve only the left in isolation. So if you only concentrate on the right ventricle you are going to miss the forme fruste cases on the left side. At some point I suspect they are going to change the name all together when they find something else.’

(Cardiac Pathologist 3)

In the cardiology/cardiac genetics clinic, left ventricular penetration of fibro-fatty tissue would rarely be considered due to problems associated with imaging the structure of the ventricles of the heart (te Riele, et al 2014). Although due to the complexity of ARCV, clinicians take a multi-modal approach to the diagnosis of a patient, the approaches taken are limited by the extent to which the clinician can examine the heart of a live patient. Cardiologists are often limited to observing gross anatomical changes such as the

dilatation of the right ventricle (visible through the use of Cardiac echo) or through ECG changes which can present changes to the conductivity of the heart as well as measuring arrhythmia (McKenna et al, 1994). All of these cardiological presentations can be accounted for in the diagnosis of other cardiac conditions, such as dilated cardiomyopathy (DCM) or Brugada Syndrome. This is a particularly important issue as pathologists can come to a completely different diagnosis to a cardiologist, as this pathologist discusses:

'I did have a heart once that I was told was Brugada syndrome and it was actually Arrhythmogenic Cardiomyopathy. I discovered that the Italians of course had described this variant where the patient has the phenotype of Brugada and the morphology of arrhythmic... and that patient had a brother and a mother who both had the same phenotype and presumably therefore had the same genotype and actually had arrhythmogenic cardiomyopathy when they were thought to have Brugada. So I put his bottom line as being this actually Arrhythmogenic cardiac sort of overlap syndrome as opposed to the Brugada syndrome it was sent to me as... And of course in the Brugada syndrome you expect to see nothing at all in the heart where as he had morphological changes in the heart, that might be one of the ones where you would say; 'why do you need an autopsy we have got an ECG diagnosis the autopsy will be normal. Because it was done it showed the diagnosis was different.'

(Cardiac Pathologist, 5)

In this instance the cardiac autopsy is considered to be the definitive 'gold standard' (McKenna et al 1994, p. 215). This suggests that ARVC, or as pathologist prefer ACM, is a pathological entity, in that the accepted, definitive mode of diagnosis is the pathological and histological examination of the whole heart. However, the other condition described in the above quote, Brugada Syndrome, is only made visible through tools employed by clinical cardiologists. Brugada Syndrome is produced as a diagnosis following a series of



ECG based tests, which will produce a typical 'shark fin' presentation by way of coved type ST segment elevation visible on the reading of lead v1 or v2 either spontaneously or through therapeutic provocation (Priori et al 2013). On this basis both diagnoses are correct, this brings into question which aspect of the condition constitutes the *forme fruste*, is it the Brugada presentation on the ECG or the ACM/ARVC findings post-mortem? It is widely accepted that distinctions will persist between different disciplines' constructions of what can be considered as the same object. Mol's (2002) influential monograph *The Body Multiple* powerfully illustrates how atherosclerosis is multiply constructed in medical professional practices, resulting in the emergence of subtly different atherosclerosis's based upon how it is measured, by whom, in which context and for what purpose. On this basis, it can be argued that both diagnoses remain valid. Like Mol claims, these differences in diagnoses need not be problematic, the clinical diagnosis from the cardiologist serves as a means to assess which therapeutic intervention should be applied to the patient, with therapy equating to reducing the harmful effects of the disease. In contrast, for the pathologist the diagnosis serves as a way of identifying a cause of death, or a cause of the failure of the heart when examining an explanted heart.

It is only where the epistemic cultures overlap or 'where multiple worlds are organized ecologically around issues of mutual concern and a commitment to action' (Clarke and Star, 2008, p. 13) that there is a possibility for a confrontation to arise. Mol claims in these situations that the disease is co-ordinated into a singularity, disparate meanings achieving some form of coherence through inter-professional work and translatory technologies (notes, files, case conferences (MDT's)). This research puts forward a different position, notably: rather than achieving a singularity there is simply a performance of coherence for the pragmatic purposes of the inter-professional work. This is most evident in discussions by pathologists of ACM/ARVC and how they communicate this to clinical colleagues:

'We just call it arrhythmogenic cardiomyopathy, ACM, but yes, but then you have to explain to them you mean right ventricular.'

(Cardiac Pathologist 5)

The pathologists I was able to discuss this with refer to ACM/ARVC as ARVC when discussing this with clinical colleagues regardless of their own professional understanding of the condition. This shows contemplation firstly of what the pathologist considers the disease to be, then also a contemplation of the function of the interaction in which he/she is engaging as well as the perceived characteristics of his/her audience. The pathologist in the above quote perceives her audience to consider the disease as involving only the right ventricle. As the function of the interaction is to inform clinicians of the familial risk to surviving family members, the fact that the pathologist found fibro-fatty replacement in the left and right ventricle has no bearing. In keeping with Reyes-Galindo (2014), this departs from discussions of boundary objects (Star and Griesemer, 1989) or trading-zones (Galison, 1997), in that there is no illusion of an equal footing. Instead there is an acceptance that the information provided by the pathologist is pertaining to an issue under the cardiologist's jurisdiction. As a result, the pathologist produces an account of ARVC, which is perceived to be in line with that of the cardiologists and geneticists.

Although matters of nomenclature do not directly impact the diagnosis or treatment of patients or their families, the practices and understandings which scaffold the construction of the nomenclature drawn from different epistemic cultures can have an impact upon living people. For example the earlier conflicting diagnosis between ACM/ARVC and Brugada would not have had any implications for the case/patient as they had already died, but understanding the phenotype as ACM/ARVC as opposed to Brugada syndrome could better serve to risk assess family members. The same pathologist presented a similar case in which her diagnosis had a direct impact on the management of living patients:

'I made that diagnosis in a cardiac explants years ago and was told... I went back and said it was arrhythmogenic cardiomyopathy and was told it can't be because she didn't have an arrhythmia, that's not what she presented with, when in fact I think about 30% of them present as dilated cardiomyopathy, but I suppose that's when it was in its early stages and people didn't know that. But the importance there... that was a 30 year old woman with a 10 year old son so, I think back then we were saying that sort of 30% are thought to be genetic but I think it may be more now again which obviously it is important to the patient. I mean with an explants you have still got the patient as well, you're not bedevilled by people saying well their dead so what difference does it make.'

(Cardiac Pathologist 5)

As the patient in this case did not present with arrhythmia (visible via ECG) the diagnosis of ACM/ARVC was not considered; also cardiac dilation was considered to be a rare presentation of ARVC in the clinic. However when the heart is examined pathologically it is expected that the organ is examined in its entirety. Even though clinical information pre-mortem or pre-transplant is an important resource for the pathologist, it does not focus their investigation at the cost of ignoring other pathology. As such, the account of the diagnosis provided by the pathologist stands in tension with that of the clinic. Debates concerning the multiplicities of social constructions of diagnoses are well versed (Brown, 1995; Jutel and Nettleton, 2011). Gardner's et al. (2011) *Patchwork diagnosis* explores how the accumulation of medical interactions and interventions constitutes the final diagnosis, and whilst this is indeed the case here, the patient was ultimately diagnosed with a single condition. By viewing, as Jutel (2009) does, diagnosis as a process and a category, the conflicting diagnoses provided by the cardiologist and the pathologist can be seen as part of the process of diagnosis, resulting in an accepted diagnostic category. This is an explicitly political process in which the final diagnosis is derived from the systemic

acceptance of jurisdiction over particular aspects of medicine, the pathologist maintains jurisdiction over the diagnosis of patho-physiological changes to the heart. This point is laboured in the guidance on the diagnosis of ARVC, in which the autopsy is defined as the 'gold standard' diagnostic practice (McKenna et al, 1994). The pathologist in this case ensures her diagnosis is accepted, in this case due to the implications of it to the patient's son. This serves to extend the pathologists focus beyond the case through to the pedigree and thus the object of investigation is aligned with that of the geneticists.

The *forme fruste* cases/patients offer a unique opportunity for those interested in the sociology of medical diagnosis, not only because that which is considered abnormal in one medical discipline can be considered as part of the standard definition of the disease, but they also offer the opportunity to examine how conflicting diagnostic categorisations are resolved in practice. By focussing on such cases we can explore how the unusual is 'worked' into an acceptable category, by emphasising how some aspect is consistent with an existing category and playing down others which are not. As has been shown this results in different diagnoses depending on the field in which the alignment is made.

From this point, I ask what constitutes a separate disease entity in the field of ICC's in which there is a huge amount of overlap in clinical diagnostic categories across the disciplines concerned with making diagnoses. This can be seen in the above example of ARVC in which I present two examples where a patient/case presents features of multiple ICC's, consistent with the accepted diagnostic criteria for each condition. Different fields of medicine cannot create multiple different disease categories for a set of symptoms or features described elsewhere. Nevertheless, there remains a great overlap between conditions in the field of ICC's. Much of this stems from developments in different fields of medicine and science, which create connections between conditions otherwise thought to be separate.

The identification of gene mutations associated with many ICC's has been the primary connecting factor between multiple phenotypes. Hershberger et al. (2013) presented a review of the genetic 'architecture' of Dilated Cardiomyopathy (DCM) in which he presented 39 genes associated with DCM, of these only 12 were solely associated with DCM all of the others were also associated with other ICC's, most commonly Hypertrophic Cardiomyopathy, sharing 20 associated genes. The complexity and overlap between ICC's has been a frustration for cardiologists and geneticists for some time, a paper which discusses this refers to the famous H.L. Melken quote: *"For every complex human problem there is a neat and simple answer that is wrong ..."* (Chen and Chien, 1999). Indeed, it is increasingly accepted that what were once considered monogenic disorders are now considered oligogenic or polygenic:

'We are pretty much aware that if we want to focus our selves on Mendelian genetic disorders: A: a lot of what we are dealing with is not strictly Mendelian, we've picked the low hanging fruit of the strictly Mendelian behaving diseases. And B: much of what we are dealing with in arrhythmia syndromes and cardiac genetic disease is actually oligogenic and while it sometimes seems to be inherited in an autosomal dominant fashion its actually much more complex than that, Brugada syndrome being the best example.'

(Cardiologist 4)

The overlap in both the phenotypes and genotypes of ICC's such as Brugada Syndrome and DCM makes synthesising accepted and bounded definitions of each of these conditions difficult. Whilst the transient nature of categories and classifications is well known (Lampland and Star, 2009), the indistinctiveness between these conditions at multiple epistemic levels makes the measurement, quantification and practical mobilisation of these classifications through diagnosis incredibly difficult. This results in variable diagnoses, not only between clinical fields but also within fields between clinicians.

Ultimately, a set of symptoms or features are 'worked' into an acceptable diagnostic category in the majority of cases. It is important here to note the earlier chapters of this thesis, which discuss the practical limitations to the interventions available to medical practitioners when attempting to establish a diagnosis in a patient or family (Part I). It is often the case that a diagnosis is worked from a constrained position, and whilst work is done to ensure that patients have access all necessary resources, this is not practically achievable in all cases. Nevertheless, the clinician arrives at something of a diagnosis based on the resources available. In the clinic, when comparing this to the medico-legal setting, not arriving at a diagnosis not only risks the professional reputation of the individual clinician or professional group but also the health of the patient in whom therapeutic interventions are applied.

The purpose of this section was to present the complexity and mutability of diagnostic categories in the field of ICC's across medical disciplines. Thus, ICC's are not only multiply conceived and enacted based upon disciplinary situated practices and technologies associated with seeing them, but these multiple conceptions are also uncertain. The implications of this for inter-professional practices associated with *patchwork* diagnoses are quite significant, not because the uncertainties are hidden, but because they can be interpreted and valued in multiple ways by those who mobilise the collated information, weighing up the evidence to build a clinical picture.

## 11.4 The Usefulness of SADS

With the indeterminacy of medical diagnoses and categorisations presented here, it is helpful to ask why it is that uncertain categorisations are used within inter professional practice in relation to the diagnosis of ICC's, beyond the therapeutic agenda. In asking this, this section will discuss the usefulness of SADS. It has already been established that there is the perception that 'We don't have anything called SADS' (Cardiologist 6), there are no SADS clinics in the UK and no patient has SADS, yet the term remains in use. The term is used in the medico-legal investigation (See Part II), but it is accepted that it is used to represent the limits of the pathological investigation in its ability to define the cause of death. It is a black box in which deaths of unknown cause which are perceived to be of cardiac origin are placed.

However in Part III, in which the rationale for using the term SADS by coroners and pathologists is examined, I argue that there is a perceived function of the term. It serves to highlight the potential presence of an inherited cardiac condition to the family of the deceased and subsequently the clinical domain which has the jurisdictional responsibility to prevent deaths associated with ICC's. This section will examine the practical mobilisation of SADS, how it is not enacted as a neutral term but done so with a particular therapeutic agenda in mind. In doing so I will also develop an analysis of reading and writing disease, which will consider how the disciplinary reading of a condition can vary from that which is subsequently presented within inter-professional interactions such as the MDT or the coroner's inquest.

This section will examine SADS as a Boundary Object (Star and Greisemer, 1989), in that although the term maintains a robust identity across disciplinary boundaries, it is interpreted in multiple ways depending on the constraints and needs of the local disciplinary environment. However, in keeping with the theoretical considerations

embedded within this study this section will introduce performativity as a key concern when examining the mobilisation of the boundary object, by asserting that SADS as a boundary object is performed in such a way as to influence the perception of it and the presenter across the boundary. This is an explicit recognition of the criticism of the boundary object in that I present the boundary object as inherently political, with each user bringing with them a preconfigured agenda as to the function of the inter-professional interaction. An example of this can be seen in the previous section in which a pathologist chooses to present what she understands as ACM as ARVC as way to ensure that the clinicians knew this was what she was referring to when presenting autopsy findings referring to bi-ventricular fibro-fatty replacement.

### *Reading and Writing Disease*

In the qualitative social sciences, the extent to which we are able to accurately represent the field we are researching has been continuously debated since the 1980's (Clifford and Marcus 1986). Following this reflexive turn it has been commonly held that any representation produced will not be able to accurately reflect the truth. This is reflected in quotes such as: "social scientists can only claim to speak on our behalf by refusing to let us speak for ourselves" (Ashmore, Mulkay and Pinch, 1989, p 208). This can be extended to any other account produced and presented to others not themselves part of the experience. This can be seen in Berg's (1996) discussion of medical records, in which he describes how the practice of writing medical notes is productive, it creates an account of experiences, information and observations. Anyone reading this account will not read a reproduction of the clinical interaction, they will get a selective account of the details the writer thought were of note or of potential use in the future.

Whilst the actual practices of reading and writing are not at stake here, the producing and receiving of accounts of practices, experiences and understandings of disease are. I use the terms 'read' and 'write' as the way someone experiences and understands (reads) an



object or situation will not be the same as the way he/she presents it (writes). The read is disciplined in accordance with the individual interpretation based upon a variety of epistemic and ontological factors and the write takes this interpretation and performs it in accordance with the agenda of the presentation as well as the (perceived) characteristics of the audience. This is in keeping with Myers (1990) *Writing Biology* in which he argues that writing in biology is an explicitly rhetorical endeavour. He argues that biologists write in accordance with the purpose of writing as well as the disciplinary expectations of writing as a biologist.

Based upon this understanding, making a case for SADS garners further meaning in that SADS is produced by the coroner and the pathologist with the function of informing the family they could be at risk and to instigate the clinical process for the family of the deceased. Thus, the usefulness of SADS lies not in its power to describe a particular disease aetiology but in its ability to connect medico-legal and medical systems with the agenda to prevent future deaths. Coroners are legally mandated to report upon any circumstances that arise during an investigation which are perceived to create risk of future deaths and which he/she believes action should be taken to reduce or prevent such risk (Coroners and Justice Act 2009, Schedule 5 Para 7). Although reporting SADS cases is beyond the remit of this legislation, the ethic of public health and prevention of death is visible throughout the coroner's investigation:

'It's part of our role, you know you've got a young person who might be in their late teens or their early 20s who's got sudden cardiac death, in some ways you could argue that that's not natural, most young people don't die do they? It's important as a coroner that you find out exactly what happened and ensure that if there's... And it fits doesn't it with your report to prevent future deaths. It's not a report you write but you have a responsibility when you are made aware that

there might be something here that might impact on other people. If you don't do something about that, it's just not right is it?

(Coroner 9)

This has been presented to me as the coroner's 'public health role' (Coroner 9), part of their duty as a 'public servant' (Coroner 4) and a responsibility to ensure the 'family are at the heart of the service' (Coroner 9).

Although I have no direct observations of the transfer of information from the medico-legal domain to the clinic, coroners and pathologists did report on the methods they employ to pass this information onto the clinical setting, as well as comments on the function of the term SADS from both the medico-legal and medical domain.

#### *The usefulness of SADS*

As has been discussed with reference to cardiac genetic testing, and the molecular autopsy, 'usefulness' refers to the ability of an object or technology to fulfil a particular practical function within the space it is being implemented. For the coroner and the pathologist the use of SADS is presented as a useful term for clinicians - it serves as a red flag, which is easily identified as signifying a potentially genetic unknown cause of death, and for coroner's purposes it is an unsatisfying term:

'[SADS] is a pragmatically useful description of... that sort of acknowledges that we don't know everything yet. It is not a diagnosis, it is a category within which we should try to resolve to not put cases in it if we can find a positive reason for some other cause but at the end of the day it is a clinically and epidemiologically useful descriptive category for those cases that potentially we can't sort out.'

(Cardiac Pathologist 3)

In terms of the professional jurisdiction of the coroner and the pathologist, using the term SADS on a death certificate or on a post-mortem report serves no legally mandated function. Yet it is used on death certificates and post-mortem reports. Even in situations where a cause of death is found, such as HCM, a narrative explanation of why SADS is used is also reportedly given. Two specialist pathologists from a prestigious centre in England talked about the process that using terms such as SADS instigate when it is placed on the post-mortem report:

'A. I have directly communicated with GPs to say this patient needs to be referred for this reason, and GPs have phoned me up saying; 'I have seen your report what do I need to do' and again we make sure we do provide access through that. But often my report will say families should be sent through for screening so there's a clear steer for what they need to do.

B. Yes I mean I've done that and it's usually communicated back through the coroner's officer, but I've also done it directly. If I'm expecting the GP to make a referral I will call them and say I expect them they are likely to come in to be referred, obviously it's the families choice if they want to be referred or they wish not to know.

A. We used to have a system where by following communication from the coroners we could get the cardiac genetics nurse here to contact the GPs directly and then sort out all the referral process and then the GPs didn't even have to think about it they just had to sign the referral form.'

(Cardiac Pathologists, 6+7)

SADS as a term is not used in isolation in this case. It is supplemented with an explicit explanation of what the pathologists expect from those who receive the report with SADS on it. These pathologists report checking up on GPs to ensure that they are conforming to

the expectations of the pathologists in sending them the post-mortem report. In this act of jurisdictional flexibility the pathologists actively aim to shape GPs', coroners' officers' and families' understanding of SADS by giving clear explanation both of what they mean by SADS as well as what they expect by using it. This practice of contacting local GPs, in addition to the comments on the post-mortem report, is reported by other pathologists as a way of ensuring further referral is made to specialist clinics. This practice, which goes far beyond the jurisdiction of the pathologist, is justified based on a lack of confidence in the general practitioner to be able to effectively mobilise the post-mortem report as a way of referring family members into the clinical system:

'Of course we have got a standard paragraph that we put at the end of the report. What I actually do, just because most pathologists are a bit obsessive, I actually ring the general practice and ask to speak to the practice manager and she has never spoken to a pathologist before so she answers the phone and I say; 'you will be getting a report through the post, text me when you have shown it to the responsible Dr'. Because a GP gets 50 pieces of paper a day most of which are asking to do something which requires a form to be filled out or a patient to be seen so it is important to make sure that the relatives get the information which they seem to.'

(Cardiac Pathologist 1)

Although this pathologist justifies his action in terms of the characteristics of his professional group, being particularly obsessive, the work undertaken by pathologists to ensure GPs understand the expectation put upon them when receiving a SADS post-mortem report is more related to the GP's perceived 'social distance' (Simmel, 1950; Reyes-Galindo, 2014) from SADS and of pathology and genetics. For this reason, pathologists often provide details of the local cardiac genetics service or liaison nurse. In further examples, the lack of faith in the GP means that they are excluded from the process

as a whole, and referrals were directly made to the genetics service with a few systems across England and Wales with formalised protocols for achieving this.

The rhetorical use of SADS by the medico-legal domain becomes synonymous with referral into the clinical domain of the cardiologist and the geneticist and it serves as a way to pass on responsibility to the clinic:

'We will wait until all of the analysis has been done. On the back of that is how we will find out whether the family will need further testing and whilst the coronial process will then stop because we will have the exact cause of death. The family will then be referred into this system, either by their GP or directly with the pathologist anyway, so we don't just say 'oh it's a sudden cardiac death' which technically is a natural cause of death.'

(Coroner, 9)

This quote is helpful in distinguishing how SADS is read by the coroner compared to how it is written (i.e. the account given of it). Her legally mandated view of SADS is the acceptable natural cause of death, but the account given of it is of the potential genetic condition in which other family members may be of risk, and as the passing responsibility onto 'this system'.

This presentation of SADS is carried through consistently to the clinical setting in which health care professionals use SADS to discuss with families why they have been requested to attend clinic. Although there is a resistance to using the term SADS due to its lack of descriptive clinical value it is reportedly used as a way to ground families understanding of what is going on:

'I think using the term SADS is the one that the families tend to understand... not understand, they have heard it and all of the leaflets that we use. They tend to talk about SADS in it, and so that's why I tend to use it but just to explain that's what

the leaflets will say and this is what it means. We tend to describe it to them, and then say 'this is what you will see written down everywhere', but I think it's really important for the clinical screening that we explain to the relatives that what we are trying to possibly exclude this rare list of conditions... I think the SADS term is one that the families and the patients tend to be more familiar with because of the literature that's out there.'

(Specialist Nurse, 3)

SADS as a boundary object in the examples given from the medico-legal and clinical setting is used as a political strategy to align the audience, in this case the patient, with the presenter's agenda and way of understanding what happened to the deceased family member and the potential risks to the surviving family. It is used as an access point for health care professionals to engage with family members, as a commonly understood term. Due to the disproportionate distribution of power in the clinical setting, health care professionals then work a definition of SADS into a clinically accepted category:

'Within that SADS we have got the ability to say this SADS patient was congenital long QT, that SADS patient was Brugada, that SADS patient was Hocum, or whatever else.'

(Cardiologist 5)

Here SADS is mobilised as a category which needs further refining by supplementing it with further clinical categories.

There are many acronyms associated with what is broadly considered SADS used across the world including: SUDY (Sudden Unexplained Death in the Young); SUDS (Sudden Unexplained Death Syndrome); SUNDS (Sudden Unexplained Nocturnal Death Syndrome); SDS (Sudden Death Syndrome); SCDS (Sudden Cardiac Death Syndrome); SADS (Sudden

Adult Death Syndrome); and SADS (Sudden Arrhythmic Death Syndrome). Whilst many of these refer to subtly different phenomena, and some can be seen as explicit drives towards western medicalization of cultural phenomena (See Adler (1991) for an interesting discussion of the Centre of Disease Control (CDC) response to SUNDS in Hmong refugee populations in California), the meaning of the acronym becomes almost irrelevant in practice.

When conducting interviews with professionals across medical and medico-legal domains I asked the purposely ambiguous question: 'What is SADS?', in clinical practice SADS tended to be reported to refer to Sudden Arrhythmic Death Syndrome, whilst in the medico-legal setting the meaning becomes far more ambiguous. When discussing SADS with one coroner he hedged his bets: 'When we have a... Um... Sudden unexpected adult arrhythmic death syndrome we...' (Coroner 3). This is likely a result of the fact that coroners will not see the arrhythmic aspect of the condition, as such the arrhythmic aspect is irrelevant to the understanding they have of SADS. When SADS is mobilised in practice on a death certificate the meaning of the acronym loses its value as it is used as signifier or a red flag that is recognisable by the clinical setting. In this way the multiple understandings of SADS become irrelevant as long as the sentiment associated with the purpose of its use is maintained across borders. Clinicians recognise this in their response to seeing SADS on the death certificate:

'I think from a medical perspective [SADS] is helpful because you know when you say SADS people take notice and it gets the attention of our cardiologists or my consultant.'

(Specialist Nurse, 2)

SADS does not gain its explanatory power based upon a shared understanding of aspects of what it is but of a shared understanding of the purpose of mobilising SADS from the medico-legal setting to the clinical setting. Health care professionals understand SADS as a

red flag because this is the purpose of its use in this situation. This is of course a simplified conception of the inter-professional relationship which will be elaborated upon in the next section, as this situated example fails to take into consideration the work of specialist cardiologists and geneticists in encouraging coroners to flag up these 'SADS' deaths through systematic engagement with coroners across England and Wales. Clinicians have also actively campaigned the chief coroner to ensure guidance is given which recommends that coroners flag up SADS related deaths at the very least to family general practitioners. Thus, there is a relationship of mutually shaping of what SADS is when it is mobilised within inter-professional practice.

By examining how multiple interpretations of SADS are accepted within and across professional boundaries, as well as discussing the multiple approaches to and understanding of ICC's, simplistic understandings of the medicalization (Conrad, 1975) or geneticization (Lippman, 1991) of SADS lose much of their value. The following chapter will discuss how multiple conceptions of SADS and ICC's figure in the professional organisation of the diagnosis and treatment of the conditions considered here. In this chapter I will put forward the importance of recognising that there is not a single regime of truth (Rose, 2001) in the management of SADS from the medico-legal setting, through to the multiple disciplines involved in the clinical management of patients.



## Chapter 12: From Sudden Death to Cardiac Screening

Whilst the previous chapter discussed the multiplicities in the understandings of what SADS is and how it is mobilised with a particular function, this chapter will focus on the professional organisation of those who work with and around SADS in the clinic and in the medico-legal setting. The following account fleshes out who is involved in the diagnosis and treatment of SADS/ICC's as well as how and why they work together in the way that they do. Central to this chapter is a problem identified in Charles Bosk's *Forgive and Remember* (1979), notably:

‘How a professional group copes with the existential problem of the limits of his [sic] skill and knowledge.’

(p. 5).

Instead of focussing on how each group maintains their professional jurisdiction in spite of their professional limitations (Abbott, 1988), this chapter examines how inter-disciplinary practice is utilised as a way of achieving the practical functions of diagnosis and treatment because of the limits in the skills and knowledge of each profession. In doing so this chapter will draw upon previous sections which argue that there is no one dominant regime of truth (Rose, 2001) within the professional organisation of the identification, diagnosis and treatment of SADS. Indeed it is the multiple conceptions and presentations of what SADS is as well as each professional groups place in the organisation of this system that shapes inter-professional practices.

Within the identification, diagnosis, management and treatment of ICC's professionals are inevitably going to reach the limits of, not only their own skill and knowledge, but also the limits of what they have the licence and mandate to practice. This has been presented as a

result of the development of the medical knowledge base in which one cannot be expected to be able to have a practicable working knowledge of all aspects of medicine which will be relevant to the modern patient (Becker and Strauss, 1956). Everett Hughes (1971) similarly noted:

‘The amount of knowledge available today is so great that the proportion of it which any one man can master is smaller than before.’

(p. 122)

This ethic is followed through by practicing clinicians, when discussing specialisation with a specialised paediatric cardiologist he outlining the necessity for such an approach:

‘Medicine is moving at such a rapid pace that it’s impossible to provide excellent care in many different fields. Again, I’m a subspecialist cardiologist, I’m in paediatric cardiology already, which is a subspecialty and within that inherited cardiovascular disease, is a very small niche area but I think it’s the right approach. It’s very difficult to be very good at lots of different things.’

(Paediatric Cardiologist, 1)

Moreover, the medical professional environment has developed to directly involve a diverse range of professionals in the management of patients. This process has been supported by NHS England (2013a), in their Integrated Care agenda which highlighted key areas of concern in the treatment of patients with complex medical conditions. A primary cause of concern was the fragmented nature of the organisation of the health and social care service, with each discipline/speciality separated within their own individual camps. Communication issues emerge as the primary factor impeding the effective management of patients, resulting in delayed or duplicated care. Indeed studies have reported that ineffective communication practices within a multi-disciplinary health care setting has had detrimental impacts upon patient care (Oh, 2014b). Moreover, the problems associated

with the functional organisation of care (McKee and Healy 2002), in which health care professionals with related skills or expertise are grouped into separate departments are not solved by the mere existence of the multi-disciplinary team. Collaboration requires work and management and can itself result in conflict between and within professional groups.

A focus on this conflict has dominated the sociology of professions since the publication of Abbott's (1988) *The System of Professions*. This inter/intra-professional conflict is most commonly presented in the practice arena where professional groups work to maintain or extend jurisdiction over a particular field of practice, this is due to the perceived fluidity of a dynamic workplace as opposed to the relative stability of the legal or public sphere.

Many studies have examined jurisdictional disputes in the multi-disciplinary health care environment in which bounded roles and practices are difficult to maintain (Sanders and Harrison, 2008; Nancarrow and Borthwick, 2005; Liberati et al 2016; McNeil et al, 2013). Many report particularly acute issues when examining emerging professions in which practices overlap with existing professional groups (Baeza et al, 2016; Timmons and Turner, 2004), or cases where existing relations are compromised due to the extension of traditionally held jurisdictions (Svensson, 1996). An exception to this is Davina Allen's (1996) ethnography of nursing practice within an NHS hospital, in which she found that the accomplishment of negotiating inter-disciplinary boundaries by nurses in practice was achieved with little conflict. Similarly, this study observed no cases of jurisdictional dispute in practice and status-quo was maintained throughout observed interactions. Even where there was a clear overlap in practices, professionals maintained a pragmatic approach to collaboration, this observation dilutes the historic preoccupation with jurisdictional boundaries and conflict.

Where Allen (1996; 2014) observed that the organisation and management of professional boundaries is taken for granted in nursing practice, this chapter will examine

how professionals are active in the management of jurisdictional boundaries with the agenda of securing the success of the purpose of the interaction. Additionally, where other studies have demonstrated that threats to professional identity are the key failure of inter-professional practice (McNeil et al 2013), I will explore how an existential understanding of the limitations of one's professional jurisdiction contributes to effective inter-professional relationships.

In examining this, I will focus on practices within and reflections upon cardiac genetic multi-disciplinary team meetings (MDTs) and clinics, which are key sites of inter-professional decision making. It is important to define at the outset that the examination of the MDT is undertaken on the premise that the professional organisation of this space is considered dynamic (Allen, 1996). As such, professional hierarchies and occupational roles will be considered to be actively negotiated within situated practice, this negotiation will in part be a focus of this chapter. This chapter will thus primarily focus on the professional organisation of the system from sudden death to cascade screening of family members offering insight into how distinct professional groups are able to collaborate. This diverges from the narrative of the division of labour in favour of a more interconnected approach as advocated by Hughes (1971). In doing so I will draw upon the concept of 'social distance' (Simmel, 1950) to examine how a professional gains a knowledge of the knowledge, skills and abilities of others he/she works with.

## 12.1 Politics of Interprofessional Separation and Practical Collaboration

ICC MDT's are conducted across England and Wales, in fact multi-disciplinary working was positioned as a key recommendation in the National Service Framework on Arrhythmia and Sudden Death (Department of Health 2005). Thus, inter-disciplinarity has been a core ethic of ICC services since their formal commissioning. Although the shape and name of these meetings vary considerably there remains a core sentiment of a group of professionals meeting on a regular basis to discuss a particular group of patients, of which any member can present, with the intention of gaining advice, referral or access to resources available from other members of the group. The MDT's in the centre I observed were led and organised by a specialist nurse, however this is not standard across England and Wales, depending on the organisation of each service, MDT's were reportedly organised by consultant cardiologists, genetic counsellors as well as other specialist nurses. This structure holds true for the organisation of clinics whether they be joint cardiology and genetics clinics or based around a single speciality. Both, genetic counsellors and specialist nurses also reported running their own dedicated clinics in addition to the joint clinics with the clinicians. Although this resembles the extension of nursing and genetic counselling roles into the jurisdiction of clinicians (Allen, 1996; 2014), this was not positioned as such, it became a normal feature of their situated professional practice, organised in such a way with the wider inter-professional team. Indeed a specialist nurse justified her clinic based upon the constraints of the clinician with whom she worked most closely with:

'Initially the cardiac screening was done a bit haphazardly by consultants [patients] weren't really referred to specific consultants, family members could be seen by different consultants and told different things. So basically [consultant] wanted one nurse to take control of the screening so the families would all be seen

together, all have their... ideally we would love to run a one stop shop where they would come in see me have their tests, see the consultant and get discharged but in the real world that doesn't happen. I get the referrals I see the patients in clinic I arrange their tests so all that is done before they see the consultants. What used to happen is they would wait 9 months before they would see the consultant then go expecting answers from a hospital appointment and get told they needed to come back with all their tests. Now all that is done before hand.... I've been doing this job since 2006, in that time we have built up the service we do the adjmaline challenge, now they are nurse led as well so basically all their screening tests and everything is done before they are seen in clinic then I have a meeting with [consultant] and discuss the results. Anyone who is positive or symptomatic or we are concerned about obviously they are booked into clinic as an emergency. Some things work some things don't.'

(Specialist Nurse, 2)

This nurse has been involved in the running of the ICC service since soon after its inception. As such, she has a sense of the service level limitations, such as resources and time, and has organised her practice to overcome these. Allen (1994) reports that nurses take on doctors roles to maintain continuity of patient treatment, where as this study argues that the specialist nurse in ICC services performs roles traditionally associated with clinicians but as an integral part of the organisation of the ICC service (since it is not seen as a clinician's role in this space). She is performing her role as the specialist arrhythmia nurse, which includes conducting screening tests and triaging patients. Although formally the consultant has to rubber stamp diagnoses and treatments, practically these are roles that the specialist nurse can perform with the consultant. This is true for other formal external relationships with the ICC service:

'It's very difficult to get hold of PM reports, you have got to jump through hoops to get them. I have to send a letter they won't accept it from me it has to come from the consultant which is silly really so I've got to, I type the letter and get him to sign it, so it might as well have come from me but there you go.'

(Specialist Nurse 2)

The politics of separation exist externally in that the consultant holds authority to formalise decisions, but during the day-to-day running of the service this hierarchy becomes far more flexible. The consultant who works most closely with this specialist nurse presents the merits of this model of working:

'[Nurse] may coordinate [tests] in 3 or 4 different relatives, and if it's a family that gets on well I'll see them at every test and I'll see all 4 of them in the room together and we'll put aside around 40 minutes to an hour... The time from us hearing about the family to getting that done was brought from 2 years down to 6 months. So all the tests done by a specialist nurse, all of them collated and put together and put into an easy form for me and I would see 3 or 4 family members together, we would go through it with all of them... I think if I was trying to pull all this together myself I would be in the same old situation I had in the past, seeing a patient without the data, writing to someone to get it, seeing the patient 4 months later.'

(Cardiologist 5)

The consultant rationalises the professional organisation between himself and the specialist nurse in the same way as she does, explaining how her practice has dramatically increased the efficiency of the service. Yet at no point is the hierarchy or division of roles discussed, instead practice is reported in terms of pragmatic collaboration with the aim of providing a good standard of clinical care within an acceptable timeframe. These are the agreed upon terms of this inter-professional space. This relationship is aided by the close

working relationship this nurse has with the consultant; both know and trust what it is each other does in this space and thus can situate their practices around the other's skills and abilities, in which I include institutionally imbued power (access to resources) to ensure their service runs effectively.

This ethic of knowing what each other is able and willing to do within an inter-professional system is positioned as a key aspect of the system's success in this study. Referred to as 'empathy' by a senior coroner who claimed to shape her practices based upon the needs of those in the clinic, it has also been seen in other inter-professional endeavours working towards a joint goal. Interestingly in the field of ICC's, not only are clinics commonly multi-disciplinary, but professional organisations such as the Association for Inherited Cardiac Conditions (AICC) actively encourage participation and membership from all professionals who deal with ICC's, indeed the counsel of the AICC is made up of representatives from a variety of backgrounds:

'There was an initial draft constitution for electing the counsel. The decision was made very early on that it would involve cardiologists and geneticists equally and then paediatric cardiology, cardiac pathology, genetic counselling and genetic nurses were allowed on the counsel and so that immediately engaged different professional groups. That's how it began so it was the foresight who first initiated the counsel.'

(Cardiologist 4)

This move by the AICC is justified based on the shared goals of all members of the organisation:

'I think it's successful because everyone is working towards the same objective.'

(Cardiologist 4)



Moves such as this enable multiple professional groups to get to know not only how people work in the day-to-day setting of the hospital but also what each professional group values and considers cutting edge, as inter-disciplinary conferences allow for the presentation of research from all disciplines and indeed multi-disciplinary research. This can yield insight into why a clinician values one technique/ laboratory over another as is discussed within MDTs.

## 12.2 Social Distance and Professional Organisation

Social distance has been used to explain the relationship between the distance between groups or individuals and the knowledge they have of one another (Simmel, 1950), a definition that has been applied in science and technology studies to the distance between forms of knowledge of interacting disciplinary groups (Reyes-Galindo, 2014). Social distance also refers to the distance between key characteristics of individuals or groups, such as social class, race or indeed profession. However, this term can also denote the relationship between the extent to which an individual or group interacts with each other and the knowledge they have of each other. It is this final aspect of social distance which will be considered here in relation to collaborative practice in clinical ICC services.

This concern of the effectiveness of the interactions which constitute the ICC services came to my attention because, although (on the whole) the MDT's I observed appeared to run smoothly and efficiently, this is not the reported experience across the board. For instance during interviews with two separate members of a new clinic focusing on Marfan Syndrome, both the genetic counsellor and the specialist cardiologist who attend this meeting reported how difficult and ineffective it had been so far:

'The Marfan one seemed to suffer much more about miscommunication because there is much more information to be shared.'

(Cardiologist, 2)

The emphasis in this account is on miscommunication. When this is compared to accounts by the same individuals in relation to their arrhythmia service it becomes apparent that established and embedded inter-professional relationships are incredibly important to the effective organisation of clinical services:

'I think it's not so bad for the arrhythmia clinic because it's been going on for a while and they have a system that facilitates that communication in a number of ways so people don't tend to get missed. Because either they have been referred from us or we are down there when they turn up so that seems to work quite well because there are lots of opportunities to touch base about the same patients. We have a MDT meeting every month where we discuss our patients all together so I think for the arrhythmia clinic the communication is quite good.'

(Genetic Counsellor 3)

This genetic counsellor claims that the arrhythmia clinic is more effective due to established avenues of communication which have developed over the years that the clinic has been running (since 2006), as well as the extent and multiplicity of the types of communication between cardiology and genetics in relation to arrhythmia including the MDT. In addition, this close relationship between cardiology and genetics means that the cardiologist can pre-empt what is expected of him in the clinic in relation to the needs of the geneticists:

'The geneticists tend to rely quite a lot on us. They want first of all, a significant clear evidence of phenotype before they go to genetic testing. The way they run the clinic is the either get patients referred from cardiologists with a clear phenotype and they initiate genetic testing or if they get a family themselves they do all the genetic evaluation but before that they ask for a cardiological evaluation as well.'

(Cardiologist 2)

This cardiologist bases his practice on the presumed requirements of the geneticists when he is considering referring a patient to the genetics clinic. This is informed by close collaboration between cardiology and genetics at this centre in relation to ICC's as well as

the research interests of the specialist cardiologists at this centre, both of which have a strong interdisciplinary focus on phenotype-genotype correlations.

This supports the conclusion that the procedure of placing professionals from different disciplines in the same space does not produce effective collaboration (Liberti et al 2016). Simply decreasing social distance by increasing interaction does not guarantee successful multi-disciplinary practice. Far more important is what happens during the interaction as well as the variety of interactions experienced. In the above example cardiologists, geneticists and genetic counsellors do not only interact during the clinic or when referring patients, they also have a joint weekly MDT and all are members of the same professional organisations and attend the same conferences. The MDT is positioned as a site of integral importance to these professionals in that although different opinions emerge, they are worked through to a mutually acceptable conclusion during the meetings.

The initial failure of the Marfan clinic has been attributed to ineffective communication practices. This could be due to a misalignment of the terms of the interaction, the modes of communication and of expectations of each professional group, due to a lack of inter-professional experience. This can be gained through a process of situated professional socialisation. Although all participants in this study would be expected to have mastered a certain level of professional socialisation within their respective professional groups, this would not constitute a measure of the degree to which an individual professional is socialised into the workings of a particular inter-professional interaction. Whilst it could be argued that organisational socialisation (Van Mannen and Schein, 1979), i.e. the process by which an individual becomes embedded within the culture of an organisation, could be employed to discuss the level of inter-professional cohesion, this definition does not encompass the nuances of the organisation of situated inter-professional practice. This is best discussed in relation to observations where situated professional socialisation failed or was in development. The two examples given are from MDT observations. The first

example of failed situated professional socialisation comes from an instance in which a consultant cardiologist, who is a member of the MDT but does not regularly attend due to his external position, misinterprets the function and tone of the MDT.

The external cardiologist began by presenting a case of a young man presenting at the accident and emergency department with breathlessness. The initial differential diagnosis was HCM although this was not definitive, with the cardiologist admitting to doubt whilst he was waiting on a 'confirmatory' MRI scan. This cardiologist first departed from formal procedures by referring his patient to an expert in St. Barts, which was immediately bounced back by WHSSC (Welsh Health Specialised Services Committee) as the guidelines state that a patient cannot be referred out of area without special justification (See Chapter 4). The clinical geneticist present at the MDT, following a quick analysis of the family pedigree, asked whether the family had been clinically screened, as there were no suspicious sudden deaths in the family. The cardiologist said that first degree relatives had not yet been screened. As such the geneticist said when they are screened if nothing is found then the patient is 'low risk'. The cardiologist began at this point to voice his frustration:

'So you would be happy for me to put HCM as a diagnosis without genetic testing?'

To which the geneticist replied that it was dependent on the family history and that there is not an infinite budget. At this point, the geneticist also emphasised the function of genetic testing by saying:

'The other thing is, do we agree that genetic testing is purely diagnostic?'

Referring back to Chapter 5, we know that in this setting the function of genetic testing is not for the benefit of the single patient and that a genetic finding on its own is not diagnostic in a system where 'phenotype is king'. However, the external cardiologist who is not socialised within the processes and constraints of genetic testing was unaware of

these nuances as clinicians are traditionally patient centred rather than family centred. To this, the cardiologist replied:

‘So you’re not going to give him genetic testing then? It was my knowledge that in this day and age if someone had HCM they would get genetic testing.’

Here he is presenting an idealised picture of a clinical system from an external point of view in which economic constraints are diminished. Yet in saying this, he is also highlighting the lack of need of genetic testing in the first place, by suggesting genetic testing on a patient with HCM, the test would yield little useful information in relation to the management of the patient, as there would already be a clinical diagnosis.

The discussion then moved onto the current state of the budget for genetic testing with the paediatric cardiologist asking whether they came under budget last year. At this point a consultant cardiologist who attends every MDT interjected;

‘Even if we did have unlimited funding, would it still be right to [genetic] test, I thought we needed more than that, like a family history... It’s my vote in these single patient cases with no family history, there’s no point in testing.’

This changes the focus of the discussion from resource limitations to an inappropriate request for genetic testing. This ended this presentation, concluding that family screening was needed and if there were any family members found to be symptomatic then the case could be brought back to the MDT.

The external cardiologist in this case disrupted the flow of the MDT through his inexperience, firstly with the organisational structure of genetic testing, but also of the function of the MDT and the approach to genetic testing held by the members of the MDT. He assumed that the function of the MDT was to approve the use of genetic testing, and whilst this is the case on the surface, practically the function is more orientated towards managing resources and ensuring that patients are managed effectively across

professional disciplinary boundaries, with the primary function of preventing sudden deaths in patients and their families.

Around 1 year in to my observations of the MDT's, the specialist arrhythmia nurse who organised the cardiomyopathy MDT relocated. As a consequence of this, two of her colleagues, who were heart failure nurses, took over responsibility of organising these meetings. While a lot of attention was given by the specialist nurse who was leaving to ensuring that her replacements could fulfil this role, in practice the meetings became somewhat disjointed for a short period of time. This could be explained by the social distance the heart failure nurses were from the core set of attendees, in that although they were specialist nurses they had little interaction with the genetics department, nor did they attend ICC clinics. However, on a practical interactional level the issues arose more because they were not socialised into the MDT. This became evident at the beginning of the MDT, in which it is established practice for the nurse organiser(s) to begin the meeting, signalling the introduction of the first case by the clinician with whom the patient(s) are officially registered. This is in keeping with the hierarchy of the MDT, in which the nurse maintains organisational jurisdiction. However in this case the nurses did not take charge as a result, the MDT took a while to initiate.

The nurses also failed to pre-empt the actions which would result from the MDT. During other meetings the specialist nurses had the ability to predict what would be requested by clinicians as well as what information would be required based upon the clinicians presenting and the cases on the agenda. This means firstly, that a lot of preparation goes into ensuring the MDT runs efficiently. For example, as has been discussed extensively throughout this thesis, patients are seen as whole families in ICC services. However, a consequence of an individual patient focused clinical system, is that formal procedures do not represent clinical practice, and instead of being able to refer a family to the MDT or to

clinical genetics from cardiology the specialist nurse has to refer each member of the family individually:

‘it’s [organising the MDT] quite laborious the way things are referred and it’s a lot of paper work for me to do separated letters, because I thought that when you referred the family you referred the family, I didn’t realise you have to refer them as individuals so that is a lot of extra work. I referred a family the other day it took me about 3 hours.’

(Specialist Nurse 2)

In addition to all the background work that goes into organising the MDT, the nurse was also seemingly prepared for any eventuality that may have arisen during the MDT proceedings. As has been discussed a key formalised function of the MDT is to ratify claims for genetic testing for patients. This procedure requires agreement that testing is justified under the terms of the agreement with WHSSC and must be signed off by the cardiologist. I observed in many cases, upon the agreement to conduct a test, the nurse would produce an already completed genetic test requisition form as well as the pro forma document for WHSSC, ready for the cardiologist to sign as to ensure the patient received testing as soon as possible. This supports Allen’s (2014) discussion of the ‘organising work’ of nurses, Allen argues that this work serves to ensure all essential activities are carried out, or at least facilitated. However, as this aspect of the specialist nurse role is exclusive to the MDT situation, the new nurses did not do this and as a result time was taken filling in forms during the MDT or forms had to be completed following the MDT.

This situated professional socialisation is not exclusive to nurses in which flexibility and role extension is increasingly considered to be part of their role (Allen, 1996). Clinicians are equally subject to very situated professional relations, which they must learn to negotiate. This is in part dictated by an understanding and acceptance of the skills, knowledge and formal jurisdiction of other disciplinary groups, but also of the specific



social organisation of the space in which they are situated. For example, although clinicians know they maintain formal jurisdiction over their clinics, there is an admission that the specialist nurses or genetic counsellors run them, and that the knowledge that these professionals have of the families often precedes their own. Thus, clinicians will often defer to the nurse or genetic counsellor in relation to specific queries about family dynamics for example. During the MDT, professional relations are incredibly dynamic and it is an important acquired skill of the attendees to negotiate who is in charge at each point.

Significantly, unlike many of the studies taking inspiration from Abbott (1988), all members of the MDT are invested in its success, thus conflict over jurisdiction are relegated in favour of the joint mission to ensure patients and families are diagnosed and treated to the highest possible standard. Although conflict can arise between groups, work is undertaken to mediate any issues to ensure the success of the joint mission. The presenting clinician is attributed jurisdiction over the patient they are presenting to the MDT, however as each case develops jurisdiction changes. The primary reason for this shift is access to expertise, each clinician defers to the expertise of the specialist in the field of concern. For example where a case is presented which involves extracardiac features, cardiologists will defer to the expertise of the clinical geneticist who is perceived to know more about multi-system genetic syndromes. Andersen-Tawil Syndrome arose as a possible diagnosis on multiple occasions during the MDT's. This syndrome is a rare subtype of LQTS which has also been associated with dysmorphic facial features, as well as webbed fingers and toes. The consequence of suggesting Andersen-Tawil Syndrome over other forms of LQTS is that an extended gene panel would be required to encompass mutations associated with this phenotype. In one case the clinical geneticist suggested that Andersen-Tawil syndrome could account for polymorphic ventricular ectopic beats presented in the patient and was thus making a case for an extended gene panel. The cardiologist in this meeting stated that although claims had been made that the patient

had suspicious facial features, these are very subjective, and as such he prioritised the presentation of the long QT interval. Ultimately, it was agreed that the extended panel would be requested based upon the additional expertise held by the geneticist on this matter.

Authority is not only attributed based upon perceived expertise over a certain domain, pragmatically it is also attributed within the MDT based upon formal institutional arrangements, such as formalised access to resources allocated to a particular department. It is common across England and Wales for resources for genetic testing for ICC's to be allocated to cardiology departments. While there is the admission that it really does not matter where the money comes from as long as the testing is available (Cardiologist 4), within MDT practice this arrangement has a profound impact on the professional organisation of this space. As such, professionals at the MDT ultimately defer to the cardiologist to rubber stamp decisions, often superseding jurisdiction based upon expertise, although only very rarely would the cardiologist undermine the expertise of the geneticist in relation to something perceived to be in the geneticist's field of expertise. Although practically this makes the decisions made during the MDT appear collaborative, professional stratification becomes apparent when economic decisions are finalised, with the geneticist deferring responsibility to the cardiologist. This was the case when the cardiologist suggested undertaking genetic testing on a patient with the function of ruling out a large proportion of his family prior to screening. Whilst the geneticist was in support of this decision, as it went beyond the service agreement the geneticist relinquished responsibility by stating: 'I can only make the recommendation and take it to the gatekeeper for approval'.

### 12.3 Fragmented Accounts

Discussions in this chapter have thus far focussed on one side of the inter-professional relationship, i.e. how the professional negotiates their place within the inter-professional space based upon the practices and expertise others through a process of what has been described as empathy. What is missing in this explanation is how they know what they know. It is here that the importance of the extent and variety of inter-professional interactions becomes important. The argument put forward here is that the higher the amount and variety of interaction professionals have with each other the better idea they will have of what each other does and needs. This is based upon the assumption that professionals provide a situated account of their expertise, roles and needs based upon what they would like to achieve from the interaction. This can be seen in the earlier example where coroners and pathologists presented an account of SADS which was inconsistent with their experience of it within the agenda of instigating clinical action. A result of this assumption is that professionals can be seen to present less than complete accounts of their work or expertise based upon the function of the interaction and indeed the others they are interacting with. During the MDT, this was observed as the extent of expertise was selectively filtered for this setting by the geneticist. It is common in the MDT to refer to gene mutations based upon the gene they are on. For instance if a patient has received genetic testing for Brugada syndrome and a pathogenic mutation was found, it would be presented as 'a mutation on SCN5A' for example. However, the report received from the genetics lab does not simply say mutation on X gene, it will give the specific place on the gene in which there is a deletion or a duplication, but as this will not affect the management of the patient this will not be presented. Such a situation occurred during a MDT, which was unusually attended by a laboratory geneticist as well as a clinical geneticist. During a short period of time between the presentation of cases, the laboratory geneticist was having a conversation with the clinical geneticist about a particular patient

with HCM, in which a mutation was found but the location was not recorded in the notes. Although this conversation was not private, it was considered irrelevant to the rest of the group. The specialist nurse joined this conversation by stating: 'the gene found was KCNQ1', this was not incorrect as this was the gene that the mutation was found on, however it was a misunderstanding of the required level of depth that geneticists use when interacting with each other as opposed to within an inter-professional group. The laboratory geneticist replied: 'you are right, but I wanted to know the specific mutation', to which the nurse answered: 'sorry, that goes straight over my head'. This strikes a similarity with what Galison (1997) terms a *pidgin* or a simplified contact language used between two or more groups who need to establish trade. However, in the case of the MDT this language is neither purely simplified nor is it stable. The complexity a member goes into reflects the issue at stake within the particular interaction, for example an account of the nuances of measuring a QT interval in line with the Schwartz criteria (Schwartz et al, 1993) and how this can result in variable readings, can be presented if a borderline QT interval is presented. In the same meeting a patient can be said to have LQTS by a cardiologist without referring to the ECG at all. This brings into question Bloor's (1991) observation that medical practitioners did not routinely present the extent of their knowledge to those within their collegiate when registering a cause of death because of an implicit trust in the expertise of one another. Whereas these observations would suggest that the medical practitioners provided the level of detail they felt necessary to perform this routinised function. Such an instance may result in a contradiction of Bloor's observations, in that professionals may feel it necessary to go into more technical detail to those with whom they work most closely with because such detail will be perceived to be accessible.

The result of situated understandings of what other professionals do, either through practical collaboration, direct accounts or relayed accounts, which are constructed with a rhetorical purpose, means that it is difficult to get a clear understanding of what others do

or need. This becomes more profound as social distance increases. For example as discussed earlier, the Coroner will very rarely attend a post-mortem in person, yet much of the conclusion presented in court relies upon an account of post-mortem practice given by the pathologist. Whilst pathologists claim to endeavour not to filter what they put in the post-mortem report due to the legality of the document, there is an acceptance that this is a very particular report:

'I take the view that a specialist report and it has to be as accurate as possible and I tend not to put it into lay terms. We have a paragraph in our reports and say that these are reports for the coroner they are a legal document and if the parents see a copy of it they should interpret it with the aid of the clinician or their general practitioner, not to try and interpret it on their own. It's not specifically aimed for them it's aimed at them in a way but the language is not constructed for them to be able to digest it is constructed to be precise as possible in formulating, the description of the PM.'

(Cardiac Pathologist 2)

The way in which this document is constructed is based upon the perceived needs of the coroner in their investigation gained through a relatively close working relationship. This relationship differs significantly from other NHS professionals' relationship with the coroner. The pathologist, through decreased social distance with the coroner is far more socialised within the medico-legal setting than other medical practitioners. This is apparent in the spatial organisation of the inquest itself. During an inquest into the death of a young woman due to a complex medical condition, four medical witnesses were called to give evidence, two were emergency medicine practitioners, one was a neurosurgeon and the other was a pathologist. Before the inquest began, the family of the deceased were ushered into the court by a coroners' officer and sat in the front row of the court directly in front of the coroner's position. Following this, the witnesses called to give evidence

were invited in and all but one decided to sit in the row immediately behind the family, with the final witness sitting to the left of the court close to the witness stand, during the proceedings of the inquest I found that this was the pathologist. The pathologist further distinguishes himself from the other medical witnesses in the way in which he approached the witness stand. He was the last to give evidence and approached the witness stand upon invitation and continued to swear himself in from the laminated card without cues from the coroner's officer. The other medical witnesses were escorted to the witness stand, offered the option to take their oath on the bible or from the card and then given cues on when to read the oath. The format of the evidence given by the pathologist also varied significantly from that given by the other witnesses. Whilst all witness accounts were meticulously detailed, the coroner often had to ask questions to yield the information required for the investigation. For example, medical witnesses were asked to elaborate upon details relating to how the practices diverged from guidelines as well as asking for expert opinions of why the patient deteriorated so fast. The pathologist's statement in contrast was far smoother. Following the oath, the coroner simply asked:

'And the post-mortem findings?'

To which the pathologist gave a concise summary of his findings. He did not outline the entirety of his findings in keeping with the practical guidelines, nor did he announce the weight of all major organs, although he would have taken these measurements. He simply said there were no findings in each organ system except for the brain and central nervous system in which there was slight swelling. He then outlined the findings from the specialist pathologist outsourced to examine the brain, in which he simply stated he found no evidence of intercranial dissection, which was a possibility from the clinical evidence, but there was a dissection of the basilar artery, which he said was rare with high morbidity, as well as finding bleeding around the brain stem. Following this, he offered an expert prognosis based upon those findings stating that a subarachnoid haemorrhage can cause

sudden death. The pathologist concluded his statement in the format in which the coroner has to register the death:

‘Cause of death: 1a) Basilar Artery Dissection;

b) Subarachnoid haemorrhage around brain stem; caused by

Elhers Danlos type 4.’

The coroner asked no questions, the pathologist left the stand and the coroner provided the conclusion giving an identical cause of death to the pathologist in the same format.

This is achieved by the pathologist by having a good understanding of what was required of him in this setting, the statement provided contained no more or less information than he thought necessary to satisfy the legal process of the inquest.

The account given by the pathologist in the inquest can be directly compared to an account of the rationale behind the construction of a post-mortem report for medical colleagues:

‘I tend to be rather general in the cardiac ones if it is a cardiomyopathy I tend to just put cardiomyopathy rather than heart failure secondary to cardiomyopathy anything like that I just tend to put cardiomyopathy. Or, if I get a Brugada, I might say complex congenital heart disease rather than sort of going through cardiac arrhythmias secondary to heart disease. A bold statement, give the anatomical findings in the body of the report, put a brief comment but leave it for the clinicians to use their experience to interpret rather put everything down for them, which may not be valid because you don’t know everything about it.’

(Cardiac Pathologist 2)

When this pathologist is constructing a report relating to a sudden cardiac death he uses general language rather than the specific, because there is an expectation that cardiologist will be able to unpick the depth of the aetiology they need through the screening of family members. He is also assuming that the cardiologist will have greater expertise and access

to information that he does not, which could shape the diagnosis, such as an ECG reading. Accounts are not only filtered based upon the perceived situated needs of the audience and the function of the interaction, they can also be structurally constrained based upon, for example the requirements of the legal system. This is certainly true for the post-mortem report in which pathologists are required to place the cause of death within only a few points:

‘It’s like a straight jacket really that 1a, 1b, in some cases it works fine in some cases there’s 3 or 4 things and your never quite sure which order to put them.’

(Cardiac Pathologist 2)

Although pathologists routinely overcome this restriction through the use of the comments section, this format is still officially used by the Office of National Statistics when registering a death.

If inter-professional interaction is constituted by multiple situated accounts of expertise and practice, then what each group knows about each other is limited to the content of the account provided, whether this is gathered via observation of practice during a joint clinic, or through an account of practice given in a formal setting such as an inquest. As such, what one group knows about the other can be considered to be fragmented and contingent upon the extent and variety of inter-professional interaction. These fragmented accounts can have direct impacts upon inter-professional cohesion and can be seen as the main impediment to effective inter-professional practice in relation to the identification, diagnosis and treatment of SADS. These impediments arise more as the social distance between groups widens and are particularly prevalent where there is little to no regular interaction. For example there is little interface between the genetics laboratory and referring clinical centres; as a result of this clinicians who send in samples for analysis fail to understand the needs of the laboratory scientists when analysing complex genetic information:



‘Some referrers are better at giving information than others. Some of them are busy when they’re in clinic as well and they’re filling out these forms and they think it probably doesn’t matter, they know their patient has HCM and they want the HCM test and they rationalised in their head that that’s an appropriate strategy for that patient. So I guess as far as they are concerned we don’t need that information, where actually in terms of experience in a field and being able to interpret the findings it is easier if you know what the phenotype is, a lot easier.’

(Laboratory Geneticist)

The laboratory geneticist is discussing here how clinicians often simply order a test and send a sample without giving any clinical information on the assumption that the lab does not need that information. Whilst the centres which have a long standing relationship with the lab are more forthcoming with clinical information as they have learnt that this is helpful to the lab in establishing pathogenicity.

This is similarly the case when information is passed between the medico-legal and clinical arenas. The first thing to note is that health care professionals who request post-mortem reports, where there was a sudden death in a family that they are treating, consistently report that these reports are unhelpful and often not detailed enough. This can be considered as a misalignment of expectations from the clinical side as well as a misalignment of assumptions of needs from the medico-legal side. Health care practitioners in this scenario fail to take into account the limitations of the medico-legal post-mortem in terms of the burden of proof required and the highly constrained system within which the pathologist must conduct the post-mortem. When discussing this with a cardiologist who routinely uses post-mortem reports as part of the clinical investigation of families, he presented judgements of the quality of pathologists practice in relation to SADS related death:

'There's a great reluctance on the part of any pathologist for taking tissue and it's a big impediment even though they should take whatever tissue they legally need to take to get an answer... We just need everybody doing PM's (Post-mortems) and every coroner knowing what the protocol is in a sudden death victim under the age of 35. You look for all the common causes of it [sudden death], if you don't find those, there's a protocol in place. [Pathologists] now have to subject the heart to this very detailed post-mortem exam and have to take all these samples for histology and have to sample some spleen with blood for DNA analysis. And they have to refer the first degree relatives to their local inherited cardiac conditions service, if they don't do that then they have fallen down in their duties... It's not what happens but it should be very easy to make it happen. It should be 'if you are performing PM's this is a standard part of it'. So the question is if you have a pathologist who is doing a PM and not abiding by those guidelines, how are we still letting them still do them?'

(Cardiologist 5)

Even though it is accepted by cardiologists that guidelines do not represent standard practice and that sticking to these guidelines is, in many ways impractical, this cardiologist uses the specialist cardiac post-mortem guidelines as a measuring stick with which he judges pathologist's practices. As this cardiologist interacts very rarely with pathologists, the account of pathological practice he has is based upon this guidance, which fails to take into consideration the structural and practical limitations of what the pathologist can and cannot provide during the post-mortem. This clinical perception that medico-legal post-mortems are not very clinically helpful also shapes the value they attribute to them in practice. For example, there is an implicit assumption that coroners and pathologists often misclassify SADS deaths. Thus when negotiating a family history, if a number of sudden deaths arise, health care practitioners attribute significance where the coroner and

pathologist did not, particularly in cases where deaths occurred in the past, when SADS was less well understood. This arose a few times during the MDT's I observed, such as the way in which boating accident discussed in Chapter 5 was considered to be potentially significant. The scenario commonly given is the single vehicle collision:

'You can work out hypothetical scenario... a 21 year old, driving and hit the lamp post and was found dead behind the wheel, no other vehicle involved, there was no alcohol, no drugs or anything, you know just a young healthy chap, taken to autopsy and the heart was beautiful and entirely normal.'

(Clinical Geneticist 4)

Whilst this geneticist does not explicitly criticise the conduct of a pathologist when investigating such a death, he does highlight his presumption that the medico-legal post-mortem is an inappropriate tool to unveil the mechanisms of death in such a case.

Pathologists constructing an account of the post-mortem within their reports with the agenda of ensuring families receive consultation are then perhaps misjudging the requirements of the clinical setting by offering only general diagnostic criteria and 'bold statements' (Cardiac Pathologist 2).

An example of how these misalignments can cause disruption can be discussed in relation to tissue acquisition for the molecular autopsy. As has been discussed, health care professionals from within ICC services have worked to draw the attention of coroners and pathologists to the importance of storing tissue for the purposes of conducting the molecular autopsy, and although many pathologists have taken this on board, misunderstandings of requirements and abilities can cause disjunctions in inter-professional collaboration. Even where pathologists perceive themselves to be compliant to the needs of the clinic, above and beyond their own jurisdiction, this can cause disruptions:

'The most frustrating conversation I had was with someone who had thought they were doing the right thing and had taken fixed tissue and said 'oh can't you do it [molecular autopsy] with that', I took it for that reason. Of course, the point at which you fix tissue it becomes a lot less easy to get DNA out of it. It was a difficult conversation to have because I wanted to encourage him to keep thinking about doing this in the future but I also wanted him to know what is helpful and what is not.'

(Genetic Counsellor 3)

Although the pathologist is presented as misunderstanding the needs of the clinic in terms of the type of tissue required for the molecular autopsy, the fact that they are taking the tissue marks a shift towards an efficient inter-professional relationship. It is through interactions such as this that one group learns about the pressures and practices of the other. This genetic counsellor goes on to detail her understanding of why taking a sample of spleen to freeze was difficult for the pathologist:

'He [pathologist] rang me and said 'I've got this one [tissue sample], can you do X,Y and Z on fixed tissue, because I've got it but I've literally just fixed it'. I said 'we can probably work with it yea, pull it out freeze it and we'll go with it' but then I said 'you know obviously it would be ideal if we had some spleen'. There was a very good reason why we didn't have any spleen, that was because of the religious background of the individual, they had wanted the body returning very quickly so he had done the minimal investigations that he thought that he could and sent the body back to London straight away. He had been asked to weigh in as a specialist, but what he did do then and ring the guys in London and say 'Can you take a spleen sample please' and organised it. So I said it would be helpful and a good idea. He is engaged but I think sometimes he is too busy to be engaged.'

(Genetic Counsellor 3)

Through the use of corrective and explanatory accounts this passage shows how understandings of what each professional group does develops. Firstly, the genetic counsellor describes how she corrects the assumptions of usefulness held by the pathologist by suggesting that frozen tissue is far more useful than fixed tissue. The genetic counsellor also gains access to a very particular pressure to the medico-legal practitioner - that is, the pressure to repatriate the body as quick as possible due to the religious beliefs of the deceased and their family. Coroners regularly voiced their sympathy for religious groups, and whilst legally the coroner does not have to adapt practice to the need of religious communities, effort is taken to comply with their needs:

‘I mean the Muslim and Jewish communities require burial to be before the next sunset. This poses a lot of difficulty on religious grounds if the coroner gets in the way. You’ve got to sympathise with that, we have got a large Muslim community and a well established Jewish community and you have got to be sensitive to their needs, under the current system it’s not very sensitive at all actually, rather the opposite. But I think you can’t just sit back and say well that’s the law of the land.’

(Coroner 2)

As this is not a formal priority of the medico-legal practitioner, the genetic counsellor would not have access to it without the account given by the pathologist. By virtue of gaining this explanation, there is not the assumption that the pathologist is simply resistant to taking frozen spleen, but that professional pressures make the process of taking this tissue particularly difficult. As a result of this single interaction the empathy that both the pathologist and the genetic counsellor have for each others’ practice has been increased and thus future inter-professional practice can take these accounts into consideration which will aid in developing cohesion across the clinical and medico-legal boundary.

## 12.4 Mind the Gap

The space between the medico-legal and clinical setting in relation to the diagnosis and treatment of SADS does not persist simply because of a lack of inter-professional interactions. There are also structural constraints and conflicting professional priorities which restrict the transfer of information across this boundary.

The AICC produced a pathway for the management of families bereaved due to SADS (Appendix 2). This pathway reflects accounts of clinical practice reported by most clinicians interviewed. However, it fails to take into consideration the connecting mechanism between the coroner's investigation and the clinical setting; there is a visible gap in the pathway, representing the lack of a formally established referral mechanism from the coroner or pathologist to the clinic. The joint guidance on sudden cardiac death and ICC's released by the chief coroner (Thornton, 2014), states that referral should be instigated through the family GP. The problems with this assumption have been discussed earlier (Chapter 8.1). Direct collaboration is also hindered due to the perceived conflict of interests inherent in the dual role of the pathologist. All pathologists interviewed straddled medico-legal and medical practice, maintaining an NHS consultant contract as well as performing coroners' post-mortems. The overlap in these situated roles can be problematic for the pathologist, not least due to the stigma attached to doing coroners' work, at a cost to their NHS workload:

'The only way I can maintain my [post-mortem] proficiency is to do work for the coroner. Of course I am the only one that does it now and everyone says 'oh you're always at the coroners, you're never doing your own work' so you know you're actually on an uphill struggle to develop and maintain the service with very little if any support from the trust or your colleagues. It would be very easy for me just to say forget it, it's too much hassle.'

(Cardiac Pathologist, 3)

As this pathologist suggests, the local trusts in which pathologists are employed rarely include the provision of time to conduct coroners work within the pathologists' contract, if they want to continue doing this work they need to do it in their own time:

'I do the coroners as a bonus. I'm doing something that I perceive to be a useful service to the trust, even though they won't acknowledge it, because I'm the only autopsy pathologist here. So if there is a trust PM or [colleague] says 'I got this heart come in and I don't know what I'm looking at', you know the trust gets benefits. I'm the only guy that teaches on the medico legal stuff, I take trainees to inquests no one else goes to inquests, so the trust does have a positive... but it's not costed, it doesn't figure in anyone's budget it doesn't figure in my job plan so it's not recognised.'

(Cardiac Pathologist 3)

This perceived trust benefit is rarely reflected in the contracting of pathologists, resulting in a system in which there is no incentive to undertake autopsy training nor to maintain proficiency in this practice. This has been referred to as a 'time bomb' as although the number of post-mortem examinations remains high (Pounder, 2011)<sup>39</sup>, the amount of pathologists certified to conduct this procedure is diminishing and future generations of pathologists have little incentive to continue the practice.

---

<sup>39</sup> There seems to be a paradox here in which the total number of post-mortems are too high, yet there is a risk that the practice will die out if pathologists are not trained in performing post-mortems. This has been reflected upon by pathologists during interviews in which they regularly state that although more medico-legal post-mortems are conducted in England and Wales compared to most other European countries, the problem is not the total number but the appropriateness of the post-mortems. Many have presented having to do a disproportionate number of post-mortems on elderly individuals who are thought to have died of natural causes, but because they had not seen their GP within 2 weeks prior to their death, they are referred to the coroner. This is a frustration for many 'autopsy active' pathologists. Results from the pilot study of the introduction of medical examiners in a few areas of the UK, have found that medical examiners reduce the amount of inappropriate referrals into the coroner's system whilst increasing the total amount of deaths needing investigating by the coroner (Department of Health, 2016). This suggests that many investigations are indeed being conducted unnecessarily, but also that many appropriate cases slip through the net.

The majority of specialist cardiac pathologists are employed within large surgical hospitals, primarily heart transplant centres. As a result of this their coroners' work often overlaps with clinical work in that they will often be requested to conduct post-mortems on individuals who died as a consequence of surgical complications at the centre in which they are employed. The findings from these investigations can have direct consequences for their clinical colleagues, a perceived cause of tension for many post-mortem active pathologists:

'I always start with the premise that you may be asked to do the case on behalf of the coroner, the hospital [in which he is employed] may have an interest in the case. I am perfectly sanguine on the fact that I have, on occasion provided information to a coroner, which has forced clinicians who I work with and who I regard as my friends in to court to answer for various and sundry. I am relaxed with that, and I think they understand and I have never had anybody sort of cross me off their Christmas list as a result. People understand how I'm doing things and why, they must appreciate this a slightly dual role, Janus like.'

(Cardiac Pathologist, 4)

This compartmentalisation becomes an important coping mechanism for pathologists, in which they make it clear which role they are performing in each situation:

'We also have the issue of how independent do you have to be from your local trust when undertaking autopsies and where is the line of conflict of interest. Our coroner here takes the view that all the surgery here is highly specialised and you can't get just a jobbing pathologist from elsewhere to do the PM's you need an expert and so we have to be very careful about when we are working for the trust and when we are working in the interest of the coroner. I have to make it clear to colleagues that sometimes when they are having a conversation with me and I've



got my coroners pathologist hat on, not my colleagues' hat on... You have to be absolutely clear and you know if I'm doing a case and somebody says to me: 'oh this, this and this happened' I will turn around and say you do realise that as the pathologist doing the autopsy I am there on the behalf of the coroner, if you have these concerns I will have to inform the coroner. Sometimes the trust is uncomfortable with it but it has worked very well to do that.'

(Cardiac Pathologist, 7)

Pathologists are also structurally constrained when conducting coroners' post-mortems, as it is now common for coroners to enforce restrictions on information sharing from pathologists with clinicians during active investigations:

'We have been told not to talk to clinicians whose patients we are doing PM's on. When the Coroners' rules [The Coroners (Inquest) Rules 2013] changed our coroner asked us to stop sending copies of the PM reports to the clinicians, which we had routinely done with his permission because obviously they are his reports. We were also told not to invite them to come and see the PM or talk to them about it without his specific permission on each case which has to be requested by the clinician, which of course they don't do because it is a hassle. Where as we used to contact them about the PM if it was something interesting or unexpected and unusual. [The coroner] was angered by clinicians writing their clinical reports to him after they had read the PM report and incorporating it into it retrospectively. I only had a few cases of that being done blatantly in a way he felt it shouldn't have been, where it didn't represent what they had been thinking or doing before death. We have a blanket ban now on communicating with our clinicians about their cases when we are doing the PM for the coroner, which we are doing 98% of the time.'

(Cardiac Pathologist, 5)

The process of controlling and monitoring the access to information in a systematic way is indicative of the ethic of professionalization maintained within the Coroners and Justice Act 2009. The specific legislative change which pertains to the management of access to documents such as the post-mortem report is Rule 13 of the Coroners (Inquest) Rules 2013, which states that the coroner must provide access to documentation upon request by an interested party. However in doing so they maintain authority over the management of the disclosure of the document in so far as they are able to specify a time and place of access as well as being able to disclose redacted versions of documents (Rule 14). This change in legislation, although appearing to grant power to interested parties, instead grants power to the coroner, creating a formalised mechanism for controlling access to documents. Although no pathologist referred to the specific change in law that instigated this control mechanism, there is a sense in which it has made the flow of information across the medico-legal – clinical divide much more difficult.

Similar pressures exist in the transfer of information between clinical genetics and other clinical disciplines. In centres across the UK, clinical genetics services store patient information separately from their centralised medical record, historically, a practice that has carried over from the time when clinical genetics was practiced by a few regional centres, where patients and families travelled to them (Royal College of Physicians et al 2011). However, with the mainstreaming of clinical genetics services, meaning that genetics is far more integrated within multidisciplinary clinical practice, this separation can be a cause of disruption in practice. Historically clinical genetics department stored data separately from patient notes due to the family centred focus of genetics services in which data are often organised in terms of families as opposed to individual patients. Thus, the concern was to ensure family information remained confidential during other clinical interactions. However, within ICC services, a genetic finding in a patient can have an effect on the treatment they receive or the amount of clinical contact the patient has. For example, if an asymptomatic patient is cascade tested for a gene mutation which is

found in a phenotype positive family member, and is found not to have the gene they can be ruled out of further clinical interventions from both clinical genetics and cardiology. Equally, if a patient is found to have a gene mutation which helps to narrow down which sub type of the condition they have, as is particularly the case in LQTS, acknowledgement of this finding can affect how the patient is managed by cardiology services. However where the information is not shared, cardiologists are often left frustrated when treating a patient without all of the clinically relevant information:

‘As clinicians we find it difficult dealing with the geneticists, because they’re so secretive and so concerned about confidentiality that we even have difficulty getting the gene results back and into the NHS case notes. It is a big communication problem, they are on their own records over at genetics which isn’t much good if you are trying to run a joined up service. It isn’t much good if the access to those records is so restricted for confidentiality reasons that we are constantly trying to ask to make sure that we have the genetic results in the NHS case notes.’

(Cardiologist, 5)

This issue also arose during MDT meetings in which cardiologists voiced their frustration at not receiving clinically relevant information from genetics. The clinical geneticist announced that a gene mutation had been found in a patient during the MDT as a way of letting other members of the MDT know, as the cardiologists were also treating this patient. This was met with frustration from the cardiologist because it would have been helpful for him to know earlier:

‘We need these results fed back to us because he has a niece who is pregnant and blacking out, so we really needed to know this.’

(MDT6)

This was not aimed at the clinical geneticist but at the system in which results are not fed back into patient's centralised medical records. This issue has been discussed within other international research from the USA (Klitzman, 2010), in which separate files which contain genetic information are referred to as 'shadow files' that are inaccessible, which is particularly important for insurance purposes. As well as research from Japan (Komatsu and Yagasaki, 2014) that found restrictions on access to genetic information by multidisciplinary teams, mean that any potential genetic information could not be used in assessing the patient or assigning treatment. Restricting access to genetic information has its merits in that it prevents the mismanagement of confidential information, as well ensuring this information is not used inappropriately. However, it nonetheless stands as a barrier in effective collaboration across the disciplinary boundary between genetics and the rest of the health service.

## 12.5 Translators and Brokers

Although these gaps in communication persist at multiple points within the organisation of the identification, diagnosis and treatment of SADS, situated practices are performed to negotiate these constraints and ensure effective collaboration across these boundaries. For example, where it is not formally admissible to transfer patient information between the genetics patient/family files and their centralised medical records, clinical genetics utilise the interdisciplinary platform of the MDT to inform their colleagues from cardiology of any genetic test results of patient they know to be of concern to their colleagues. It is equally the case that clinicians will ask the geneticist whether they have any information on X patient or their family members, the geneticists and genetic counsellors will then feed this back via the MDT. The MDT as a 'trading zone' (Galison, 1997) does not, in and of itself guarantee the successful interaction of professional groups across disciplinary boundaries. Interaction is managed and mediated to ensure the commonly held goals remain in focus.

Within the MDT much of this work is undertaken by the specialist nurse, who have on multiple occasions referred to themselves as translators between cardiology and genetics:

'It's almost like a translator. That's how I have described it before, so I have to say relationships here between the 2 specialities are really quite good and quite robust. I mean there are times where things need thrashing out but you know and also it's about me pulling it back to the patients and what the patient or family want. Also its then explaining to the family what the different consultant clinicians think is best and a lot of the time patients go with absolutely everything. Occasionally they don't and sometimes that's me translating it back to the consultants to say you know actually no that's not happening and that's not what they want, so it is very much translator if you like.'

(Specialist Nurse 1)

Allen (2014) suggests that nurses are able to fulfil this translator role between disciplines by virtue of their experience working with a variety of health professionals from a variety of disciplines. Indeed this offers support for the social distance narrative offered thus far in that the specialist nurses have experience working with both cardiology and genetics colleagues, often filling the role of transferring patients and information across the cardiology-genetics divide. This is further supported by accounts given by genetic counsellors who claim to fulfil a similar role, in that those I was able to interview attend both cardiology and genetics clinics and thus have a good working knowledge of clinical practice across both disciplines. However, this is not presented as a role of simple translation across disciplines but a role of focussing the interaction. This is seen in the above quote in which the nurse claims to re-situate interactions onto the patient or family, their experiences and what they want to get out of their clinical experience. This is a role only the nurse or genetic counsellor can fulfil, as it is these professionals who are the point of contact for the patient/family. This extends the role of the nurse and genetic counsellor as a professional that helps patients understand medical/genetic information, to one which helps clinicians understand and maintain focus on patients. These professional groups serve as knowledge brokers between clinicians and patients, they are the means by which the one knows about the other. Ribero (2007) discusses a similar process undertaken by interpreters during transnational steel work negotiations. During these negotiations the interpreter did not translate verbatim what each party was saying but instead worked to realign the interpretation in line with the perceived cultural values of the interactants. In doing so, Ribero claims, that the interpreter utilises their interactional expertise with their client as a way of gaining an understanding of what it is that their client would want to achieve within the interaction. Thus, the interpreter's action is based upon the perceived agenda of their client.

Timmermans (2004) constructs the brokering role of medical authorities in relation to death, a role that he describes as the activities which 'render individual deaths culturally appropriate' (p. 993). As such, he is discussing the means by which medical authorities create accounts of deaths which are perceived to fit with the cultural expectations of what an appropriate death is. The role of the broker is used in a similar way here; it is the practice of creating an account of an individual, a professional group, or a practice in a way relative to the situation and in a way which is meaningful to the audience. Pathologists who maintain a dual identity are the primary source of expertise and information both for coroners with regards to medicine and for clinicians with regards to the coroner's investigation. This is by virtue of the relative lack of interaction coroners have with clinicians and vice versa:

'Most clinicians don't have much experience of the coroner, most clinicians have in fact never been to an inquest, or if they have only once. I mean I'm going to one inquest a week or so. It's completely natural to me, I don't even think about it but for them it's a big thing .... For most cardiologists there is very little contact with the coroner and when they have they're never quite sure what to do or what exactly the status of the coroner is.'

(Cardiac Pathologist, 2)

Only one of the clinical interviewees from this study had ever been summoned to give expert testimony in a coroners' inquest, although he did not attend due to a conflict of interest. The prospect of giving evidence at an inquest is not something clinicians are particularly comfortable with one clinician stating when asked: 'it's not something I am actively pursuing' (Paediatric Cardiologist).

The relative closeness of the pathologist to medicine is utilised by the coroner. As discussed earlier the pathologist is considered the primary source of medical expertise for the coroner, expertise that is often consulted when negotiating who should be selected to

give expert testimony during complex medical cases. This holds true in terms of how and what the coroner knows about specialist ICC services as well as how clinicians gain access to the practices and priorities of the coroner. One pathologist in particular reflected on this role:

‘When you are portraying the coroners legal view point, you have to be very careful to say: ‘well actually that’s the law, this is what she [the coroner] wants, this is what she is going to get. She is autonomous, she is autocratic, she says no it means no, you can try and persuade but she is actually quite a well reasoned person and she knows what she wants and if you don’t comply then she will find someone that will’. You know she is no fool and equally often the clinicians, not just cardiologists, but pathologists that don’t work with the coroner, they are completely naive about the law of the land and the mechanisms and the funding and the politics involved and they will come out with a very purely idealistic: ‘oh this needs to be done’. Yes but there’s no funding: ‘well we will have to get funding’ well how are you going to do that... You are a middleman... So I guess you are nobodies friend because you are always giving the opposite view point to the people you are talking to. You are always saying “yes but”.’

(Cardiac Pathologist, 3)

This goes beyond the earlier passage in which the pathologist negotiates their own professional identities and ensures that those around them know which ‘hat they have on’, to an account of how the particular pressures of the coroner and the medico-legal system more generally impacts upon what it is they are able to do. This relayed account of coroners’ practice serves to realign clinicians’ expectations of the medico-legal system. The cardiac pathologist above is only one of a few across England and Wales that attends regular ICC MDT’s on a quarterly basis. He presents this relationship as mutually



advantageous as he can take cases to the MDT to access the expertise of the specialist clinicians in attendance:

'We are all entitled to bring cases in, so if I've done coroner's stuff and I have found something that needs family screening, with the coroner's permission, I will refer that on to the cardiac liaison nurses to get the family up for clinical screening. I will put that into the agenda... Occasionally the geneticists get people and they want a pathological or a clinical opinion, so we will all add stuff in. I'll present the pathology or if it's an outside case, we will try and get a copy of the PM report and we'll review the slides and maybe raise issues that may or may not have been addressed by the original centre. What sometimes happens is if you get somebody who drops dead, someone refers the heart in and says: 'By the way his brother died 3 years ago under the same circumstances, only said it was ischemic heart disease'. Suddenly alarm bells start ringing because it could well have been... The concern is then that something has been missed. Or, you know there's a long list of grandfathers dropping down dead at an early age, then we do try, and the cardiac liaison girls are quite good with this, we try to get the reports and the slides if we can... I always come away from the cardiac meetings thinking, I've never considered that before.'

(Cardiac Pathologist 3)

The pathologist's presence at the MDT foregoes the problem discussed earlier in which health care professionals perceive the post-mortem report to be inadequate, as the pathologist is able to discuss this report and any available slides with the MDT and provide an account of why a certain diagnosis made. The MDT is also positioned as an entry point into the clinical system, the ICC service which manages this MDT is the only one reported to allow direct referrals from coroners or pathologists. Although this is

processed by the specialist nurse through the informal process of contacting the family GP or the coroner's office:

'A couple of times I have contacted the general practitioner and got him to sensitively approach the family and then get the coroner to contact me, and a couple of times I have gone back to the coroner's officer. Or I will liaise with the coronial team speak to which ever coroners officer is dealing with that case and then get them to discuss with the family and highlight with the family that their local service is this and my name is such and such and how to contact me.'

(Specialist Nurse 1)

This method of direct referral is advantageous as it aids in the direct transfer of information. This mode of referral is also the least labour intensive for the coroner and pathologist, which is important because although these professionals have an interest in preventing future SADS related deaths, it is not in their jurisdiction to do so:

'We knew that there were going to be problems but the conflicts and tensions have not been from within the members of the MDT but have been with, for example the previous coroner. He was not interested, it was nothing to do with him in his legal role. As a human being yes he said: 'I'd love to do it but I've got no budget and it's not my remit and the home office isn't suddenly going to fund me to do your clinical stuff, so I'm sorry and ill co-operate but beyond that you're on your own.'

(Cardiac Pathologist 3)

Similar systems have been implemented elsewhere, in which coroners and coroner's officers will actively sign post families to their nearest ICC service giving the contact details of the specialist nurse or genetic counsellor who can then formally process a referral. Indeed this has led to effective relationships between the coroner and the ICC service within two research sites in this study.

A major implication of the pathologist's presence at the ICC MDT, as explained by the pathologist earlier, is the way in which this practice connects the dead with the living. It creates a continuation from the deceased through to their surviving family, where as other ICC services second-guess what the pathologist meant in a report, here they can ask. The pathologist also keeps in mind the needs of the ICC service when conducting post-mortems into potentially SADS related deaths. For instance, he claims to routinely store samples of frozen spleen at expense to himself with the expectation this will be needed in the future. The close working relationship means that there is a large amount of professional empathy across the disciplinary boundary which extends to the practices of the coroner.

The coroner at this research site does not have contact with the MDT herself, instead she is reliant upon the relayed accounts of the services they provide and the skills and expertise they possess from the cardiac pathologist. This coroner meets the eight pathologists she works most closely with on a regular basis, around every two months. This reduces the social distance between the pathologists and the coroner, which is further reduced due to the on-site mortuary. Whilst it is debated whether this is beneficial on the whole, it does have the benefit of enabling the coroner to better know what it is that the pathologists are doing. Although this coroner had an interest in preventing SADS related deaths prior to her appointment at this site, it was the cardiac pathologist who was able to initiate the direct referral mechanism with the ICC service. She notes during the interview her knowledge of his membership of the MDT:

'We have quite a good set up here, and the cardiac pathologist that we use is also part of a cardiac genetic group at the X hospital where they would actually be dealing with these families so there's a continuity there as well.'

(Coroner 9)

The cardiac pathologist is seen as the intermediary that enables this continuity. However, the details of the system which families are referred into is not discussed in detail, the coroner refers to it simply as this system:

'Whilst the coronial process will then stop because we will have the exact cause of death. The family will then be referred into this system, either by their GP or directly with the pathologist anyway.'

(Coroner 9)

This fragmented account of what this system is, is accessed by the coroner through the pathologist who presents an account of the system in keeping with the agenda of the interaction, i.e. to instigate referral, thus the details of what the cardiologist does is not relevant. Moreover, as this is a relayed account the pathologist can only portray what he knows about the ICC service, which is a less than complete picture. Although he works relatively closely with the clinical team during the quarterly MDT, he does not attend the weekly MDT, and he has no experience of clinical interaction. Thus, the understanding he is able to portray is quite situated. This has further implications for the way in which the coroner understands the clinical system. When discussing the use of genetic testing on the tissue of the deceased, I asked:

'C. In terms of the timeframe from when you send the heart for genetic tests, how long does that usually take?

I. I'm not aware that it's particularly lengthy for us, I couldn't give you an exact figure I could find it out but weeks I would say. I mean sometimes it can be longer if it's a more complex case but I don't think it unduly delays the whole process particularly.

C. And these genetic tests are not 100% accurate, have you had any problems not identifying something during the analysis?

I. I'm not aware of any problems we have had.'

(Coroner 9)

The coroner claims to use genetic testing on the advice from the pathologist, however seems unaware of the time scale or the accuracy of the test. In fact, the centre which she works closely with and where the pathologist is a consultant does not have access to the molecular autopsy:

'At the moment because we don't have the molecular autopsy we retain tissue and then we try and find phenotypic clues, we don't do anything to the tissue until we explore the first degree relatives, if the first degree relatives there's no clues we still don't do anything to the tissue we just keep it.'

(Cardiologist 1)

This is not to say that the pathologist misleads the coroner by stating that he would like to take a sample of spleen for genetic analysis, but simply that when he has taken the spleen for this reason no testing is undertaken and the tissue remains stored until a time when the molecular autopsy is available. The pathologist is aware that the testing is not yet undertaken but continues to comply with the requests of the cardiologists to retain tissue because of the perceived clinical benefit in the future, even where the storage of tissue becomes problematic:

'One problem we get here is, I take fresh spleen and fresh blood when I do a PM and we ask other pathologists to do that when they send the heart in. The intention of that is to store it for DNA retrieval and obviously the family have to give consent and that's all sorted. But the hospital where they do the extraction don't take the specimens off us so they sit back in one of our -80c fridges and we don't have

formal consent or licence to store those types of specimens in our fridge and they are very poor at coming out and getting them.'

(Cardiac Pathologist 3)

The pathologist positions his role in the organisation of the molecular autopsy as that of retaining the tissue, as well as ensuring that consent is taken to the standard required for the HTA. This is where his role ends and the clinical system begins, as such he cannot give an account of what happens subsequent to the storage of the tissue. This has an impact upon how he, and as a consequence the coroner, understands the molecular autopsy. Moreover, it is difficult for the coroner to understand the organisation of the clinical space in which she refers families because of the lack of feedback from the clinic:

C. Do you often get feedback from the family or other professionals you are working with of the results and how it's been distributed down the family tree?

I. No we don't, it's just comforting to know that at least that family is in the right process and will get the right help and the right care. But, unfortunately we haven't had an awful lot of feedback other than if we hold an inquest. So I might then ask a family and check in the inquest 'have you been... you know [screened]' and they will tell me invariably 'yes we have been. We are going through that process we are being tested'. So at least that's comforting to some extent.'

(Coroner 9)

The lack of feedback supports the narrative put forward thus far in that the health care professionals can be seen as presenting a limited account of their practices in relation to the function of the interaction with the coroner or the pathologist. Ultimately, this boils down to ensuring that families are referred into the clinical system and tissue is stored. The details of the investigations or the findings are not pertinent to the situated

interaction, so long as it is emphasised that the referral and/or tissue could help prevent future deaths. Whilst the coroner at the site discussed stated:

‘I understand how they work, that allows me to have some empathy for what they do as well.’

(Coroner 9)

Based upon the previous discussion, the empathy she has for the practices of the clinicians is based upon a constructed account of how they work, constructed for the purposes of instigating particular actions. Whilst this is not problematic, in that it has served the function of enrolling the coroner in the process of clinical referral and tissue storage, it does limit the extent to which these two spaces can collaborate as each group only has a limited knowledge of the skills and expertise possessed by the other. Pragmatically no one can give a full account of their own work, nor could anyone else fully understand the entirety of another professional’s role. Returning to the problem identified earlier, no one person can have a working knowledge of all aspects of the identification and management of SADS from the sudden death through to the cascade screening of family members. No one professional can possess a practicable working knowledge of the politics involved in acquiring access to genetic testing in an austere health care system as well as understanding the pressures on the coroner to ensure their legal mandate is fulfilled at the same time as ensuring families are satisfied with the cause of death given. Moreover, practically there is not enough time for each professional to fully define what it is he/she can do. Each group only needs to present enough to efficiently achieve the agreed upon function within a particular context. Ultimately, the system I present here was selected due to its relatively integrated approach to the management of SADS compared to many other areas across England and Wales. Although communication practices across boundaries remain imperfect, they serve the function of ensuring the agenda of the interdisciplinary group are agreed upon. These accounts also serve to define the

organisation of this system, by accounting for each professions skills and expertise, understandings of what every groups role within this space can be distinguished, and thus practices develop in line with accounts of what each individual can and cannot do:

‘We work pretty well as a team, we have all got common interests and we all respect each others’ individual expertise. We know that any one of us can’t do it alone so we are, as much as you can be, team players, we were aware that this was a team venture.’

(Cardiac Pathologist 3)

By knowing that no one can achieve the mutually agreed goal alone, there is an acceptance that collaboration is the only practical resolution. Whereas Reyes-Galindo (2014) discussed such a relationship in terms of the trust each group has in each other, trust appears to be an artefact of the necessity of collaboration. And although there is invariably a relationship of situated trust between many of the individuals involved in this system, trust that they will perform their part, this almost becomes irrelevant as they have to trust each other because of an acceptance of the limits of their own ability to perform a defined task.

‘Respect for each others’ individual expertise’ marks an acceptance that no one disciplined explanation or understanding is prioritised, there is no one ‘regime of truth’ (Foucault, 1980; Rose, 2001) within this interdisciplinary system. Instead, disciplined understandings of the patient, the family, the condition are flexibly valued depending on the situation. There is a respect that all explanations can be correct. There is an acceptance that the pathologists ACM is as valid as the cardiologists ARVC, as long as it practically leads to family members receiving screening. This serves as a critique of the molecularization (Rose, 2001) thesis in that although there is an acceptance by all professional groups in this study that many of the cardiac conditions associated with SADS



have genetic components, this does not exclude or devalue cardiological, pathological or legal components of SADS. Indeed all of these explanations are necessary for the effective management of SADS.

## Conclusion: Making SADS Genetic

In this conclusion, I would like to clarify an on-going contradiction that has emerged as the thesis has developed. I have remarked on many occasions, in line with Annemarie Mol's *The Body Multiple*, and indeed in line with many of the preconditions of a SCOT approach, that SADS is made in multiple ways depending upon the epistemic culture in which the actor understanding SADS is located, it is shaped by socio-economic and political preconditions. Yet at the same time, I have drawn upon the quote: 'We don't have anything called SADS' (Cardiologist 6). In saying this I am diverging from Mol (2002) in that SADS is not enacted as "more than one – but less than many" (p.55), but it is instead positioned as many but less than one. Although this is somewhat pedantic, it is helpful in examining how SADS comes into existence. In this thesis I argue that it is a practical achievement that has little purpose or meaning in the space in which is made and is not useful in the space in which it eventually resides, but is useful in its mobilisation. Where Timmermans (2006) argues that Sudden Infant Death Syndrome serves to protect the professional authority of the death investigator, I argue the contrary in relation to SADS. I have found that SADS is mobilised on the basis of an internal acceptance of the limitations of the coroners' system, passing authority to the clinic as a way of taking lessons from the dead to help the living.

Much of this thesis (Part 1 and 2, and Chapter 11) is dedicated to the common focus of studies in the SCOT school of thought, in that I examine presentations of the differences in experiences, understandings and practices in relation to, what will broadly be defined as SADS, based upon disciplinary, socio-economic and political differences. Although such an approach would provide a satisfactory answer as to why the translation of the molecular autopsy into coroners' practice has been less than successful, I feel that such an explanation stops short. What has emerged throughout this thesis is a discussion of the implications of the assumptions innate to a SCOT approach to this problem. I.e. what are

the implications of differences in understanding and experiences of an object central to the practices of professional groups that must work together to solve a shared problem? Indeed, by focusing solely on the use or not of the molecular autopsy such an insight would be difficult to unpick. This is why the focus shifted to examine the professional system in which the molecular autopsy was intended to be situated. By shifting focus in this way I have been able to examine the various communication barriers and misunderstandings between the medico-legal and clinical setting. Such an examination has enabled me to ask; why would one attempt to translate a technology into a system which has little use for it and practically cannot use it due the requirements for a tissue sampling technique which is not possible in the majority of public mortuaries? This is where Chapters 4, 5 and 6 become helpful. In these chapters I show not only that there are enormous resource constraints upon clinicians, but also that these same clinicians possess autonomy to overcome these constraints as part of their role as clinicians is to provide the best service for the lowest cost. The molecular autopsy offers such a resolution. If this technology was adopted within standard medico-legal practice, as is reportedly the case for genetic testing in paediatric cases, clinically useful information would be provided at the cost of coroners' services across England and Wales. However, such an approach is based upon the assumption that coroners have to find *the* cause of death, where as in practice establishing *a* cause of death is a secondary role. It is also based upon the assumption that coroners do not have the same resource constraints as clinicians, which of course I have shown they do.

In Chapter 9, I begin to move beyond simply saying that there are differences in understandings, to showing how these differences are resolved in practice in relation to the molecular autopsy (i.e. what happens when the needs and limitations of the coroner are taken into account when attempting to translate the molecular autopsy?). This leads to two further questions: How does one group gain an understanding of the needs and limitations of another? And, how are these needs and limitations negotiated in practice to

a mutual benefit? Ultimately, the shape of the molecular autopsy has mutated, compromise has been made to ensure the technology fits within the medico-legal infrastructure, whilst at the same time maintaining as much clinical utility as possible, as well as accepting that the cost for this technology will not be met by the medico-legal system.

A conscious effort was taken in the recruitment strategy in this research to access professional systems that claim to have reasonably effective relationships across the medico-legal – clinical divide. This can be positioned as a criticism, in that the data do not represent the practice of clinicians and coroners across England and Wales. However, this decision was made on the basis that it is more useful to provide an understanding of how interdisciplinary professional systems can work as opposed to showing simply where they do not. This breaks down the idea that professions are monolithic groups, moving from the idea of a system of professions (Abbott, 1988) to a professional system. The distinction here is subtle, but the point to emphasise is that professionals do not work in isolation, they work in collaboration on the basis that they are not able to perform all the necessary roles to fulfil a particular function. The practical achievement of the professional system from sudden death to screening and treatment of family members is the focus of the final part of this thesis. This is an attempt to answer the question developed in the previous chapter considering how one group can gain an understanding of a distinct other group. This shifts the focus from examining different understandings and experiences of the same object, to examining how different groups understand each other. How they understand what each other does, what they can do, their limitations, and the way they understand the shared object of practice. This is described as professional ‘empathy’ (Coroner 9), this empathy enables professionals to adapt their practices based upon the perceived needs of the broader professional system, to further solidify this notion I will give an example from the medico-legal world. Prior (1989) identifies two distinct discourses in the social organisation of death; the public and the private, however he makes little attempt to connect these two domains although of course they work on the same object, death. In

many cases the private will have consequences for the public. Take the post-mortem examination, the way in which this is conducted and the time it takes to conduct this examination has consequences for the funeral of the individual. While Prior makes no comment on the consideration of this, the coroners and pathologists in this study reported taking great care when examining the body based upon an understanding of the needs of the funeral director and the emotional needs of the mourning family. For example, pathologists would endeavour where possible to use a Y shaped incision to expose the chest cavity as opposed to a straight incision from the 'adam's apple' as a way to ensure that no stitching would be visible when the funeral director prepares the body<sup>40</sup>. The point here to emphasise is the important insights that studying a profession within a wider social system can yield, this is supported by Timmermans (2006) discussion of post-mortem practice in the US. However, this does not answer how different groups gain an understanding of what it is each other does. It is important to note the complexity and flexibility of both the clinical genetics and medico-legal system presented in Parts 1 and 2, it is difficult to suggest that one can gain a full understanding of a specialist professional group in terms of practices, abilities and priorities. Thus, I argue that the understandings that each other has is based upon fragmented accounts and translated or brokered relationships, where by access is given only to accounts pertinent to the function of the collaboration.

Returning to the initial issue introduced in this conclusion, making SADS gains further meaning in that I present it as not being contingent on the professional identity of the presenter but upon the rhetorical function the presenter is attempting to achieve within the professional system. Thus, I argue that SADS is made genetic within this system because it is useful to do so. Although SADS has always been considered inherited by

---

<sup>40</sup> Timmermans (2006) suggests that the Y incision is universal, however this is not the case, it was claimed by a pathologist in this current study that 'Home Office' pathologists preferred the use of the straight incision. This preference is based upon the need to access the organs in the neck and the tongue, which is incredibly difficult via the Y incision.

families and professionals (Geelen, Van Hoyweghen and Horstman, 2011), this is distinct from being genetic (Hedgecoe, 2000). Making SADS genetics is useful as it provides a pathway for the referral of potentially at risk family members into the clinical system, as stated earlier (Chapter 11) it is only in clinical genetics that the extended family pedigree can be officially considered. This is not to devalue other disciplinary approaches to SADS. This is the second aspect of the research I would like to highlight in this conclusion, that is that there is no one dominant SADS discourse.

One could say that the conditions clinically associated with SADS have gone through a process of molecularization (Rose, 2001), or that there has been a subtle prioritisation of the genetic through a process of enlightened geneticization (Hedgecoe, 2001). However, as Hedgecoe shows, enlightened geneticization is a narrative used by scientists working in the field of genetics and it is thus these scientists agenda to prioritise the genetic, whilst conceding that it is not totalising. This study shows how the genetic has become embedded within the ICC clinical conscience, however this is not at the expense of other well established discourses. In fact, the genetic has been found to have very little use for the individual patient when considered in relation to existing clinical tools and techniques from cardiology and indeed pathology. Thus, this thesis offers an alternative to discourses suggesting the molecular represents the regime of truth in biomedicine, at least at the clinical level. Moreover, I would also contend that this study offers a critique of the well embedded notion of medicalization (Conrad, 1975) in that I show that legal constructions of what are commonly considered medical objects can be valid and useful in the clinical setting. This furthers the narrative of genetic unexceptionalism put forward by Will et al. (2010), in which genetic testing is seen by clinicians to have limited impact in the management of patients with hypercholesterolemia. This research suggests that the genetic is no more or less useful than any other tool or technology, it is as exceptional as any other technology in performing the task it is designed to fulfil in the clinic, which in this case is to identify at risk family members. Genetic testing for ICC's does very little to

inform therapeutic decisions, neither does it constitute a diagnosis, there are tools which can already do this. To understand the usefulness of genetic testing in this setting it is helpful to ask what the right job for tool is (Clarke and Fujimura, 1992), rather than applying expectations based normative ideas of what a clinical tool should provide in terms of individual patient benefit.

## **Practical Implications: The Interdisciplinary Usefulness of the Molecular Autopsy**

I wanted to return here to the question asked by a cardiologist when discussing the molecular autopsy:

'How can a dead person still be considered a patient in the NHS?'

(Cardiologist 4)

This question could equally be posited from the coroner's perspective; how can the living be considered within the death investigation? It is true that jurisdictional limitations preclude the consideration of the dead in the clinic and the living in the death investigation. However when considering how clinicians make a case for genetic testing for ICC's in the living patients (See Chapter 5), it becomes clear that jurisdictional boundaries are more flexible than they appear. The clinical relationship is extended from the patient to the extended pedigree, justified on the basis of attempting to reduce the risk of sudden death and the bio-political and economic rationalisation of reducing cost. This shows it is possible to make a case for extending professional jurisdiction. However, in the case of the molecular autopsy this is further complicated as it is unclear whose professional jurisdiction should be extended to encompass the molecular autopsy as it sits in the space between the coroner and the clinic.

All professionals I was able to interview stated that there was use in the molecular autopsy, yet when asked who should be responsible for the technology and pay for it answers were less clear-cut. Indeed, how the molecular autopsy becomes useful cannot be clearly positioned as within the domain of one group or the other. I argue that the molecular autopsy is only useful as a multidisciplinary technology. Access to the tissue of the deceased is a prerequisite to the use of the molecular autopsy, over which the coroner



maintains jurisdiction, at least until the end of the coroner's investigation. Yet clinicians have consistently remarked that blindly genetic testing without any phenotypical information to guide the genetic gaze is almost futile, this information is impossible to gain from a deceased individual. However, phenotypical information can be gained from living relatives of the deceased, which can guide genetic analysis. This tactic is often employed when using the molecular autopsy in the research setting as can be seen in the preface to this thesis. It is thus only when information from the dead and the living is combined that the molecular autopsy is able to yield useful information. This provides a further critique of the idea that there exists a dominant 'regime of truth' (Foucault, 1980; Rose, 2001), in that multiple disciplinary discourses are necessary, and are accepted, in the conduct of the molecular autopsy and indeed in the clinical treatment of a patient/family with an ICC. This does not definitively answer the question of who should take responsibility for the molecular autopsy in any helpful way for the purposes of commissioning, in that it positions responsibility in both the coroner and the clinic. Although this creates a bureaucratic issue of resource allocation between the NHS and the Ministry of Justice, at the practical level shared responsibility and role distribution has been agreed upon within specific spaces. This has resulted in a similar situation as was the case in the cardiac genetics clinic in Wales in the late 2000's, in which there was a will to conduct genetic tests but no resources to do so.

## References

- Abbott, A. 1988. *The System of Professions: an Essay on the Division of Expert Labour*. Chicago: University of Chicago Press.
- Abbott, A. 2016. Andrew Abbott's AMA. *Sociology Job Rumours* [online]. Available at: <http://www.socjobrumors.com/topic/andrew-abbotts-ama> (Accessed: 13/06/16).
- Ackerman, M.J., Tester, D.J., Porter, C.J. and Edwards., W.D. 1999. Molecular Diagnosis of The Inherited Long-QT Syndrome in a Woman who Died after Near-Drowning. *The New England Journal of Medicine* 341(15), pp. 1121-1125.
- Ackerman, M.J. 2005. Molecular Autopsy vs Postmortem Genetic Testing. *Mayo Clinical Proceedings* 80(9), pp. 1235-1236.
- Ackerman, M. et al. 2011. HRS/EHRA Expert Consensus Statement on the State of Genetic Testing for the Channelopathies and Cardiomyopathies. *Europace* 13, pp. 1077-1109.
- Adams, JU. 2015. Genetics: Big Hope for Big Data. *Nature* 527, pp. S108-S109.
- Adler, S. 1991. Sudden Unexpected Nocturnal Death Syndrome among Hmong Immigrants: Examining the Role of the "Nightmare". *Journal of American Folklore* 104(411), pp. 54-71.
- Ariès, P. 1974. *Western Attitudes Toward Death from the Middle Ages to the Present*. Baltimore, Maryland: Johns Hopkins University Press.
- Allen, D. 1996. *The Shape of General Hospital Nursing: The Division of Labour at Work*. PhD Thesis: University of Nottingham.
- Allen, D. 2015. *The Invisible Work of Nurses: Hospitals Organisation and Healthcare*. London: Routledge.

- Anderson, M. 2014. *Cardiogenetics: An Initial Audit of the Introduction of a Limited Genetic Testing programme for Inherited Cardiac Conditions in Wales*. Presentation for NACSiW 05/11/2014.
- Appelbaum, P.S., Roth, L.H. and Lidz, C. 1982. The Therapeutic Misconception: Informed Consent in Psychiatric Research. *International Journal of Law and Psychiatry* 5(3-4), pp. 319-329.
- Arribas-Ayllon, M., Sarangi, S. and Clarke, A. 2012. Accounting for Genetic Testing: Familial and Professional Perspectives. *eLS*. [Online]. Available at: <http://onlinelibrary.wiley.com/doi/10.1002/9780470015902.a0024171/full> (Accessed: 26/09/2016).
- Arribas-Ayllon, M. 2016. After Geneticization. *Social Science and Medicine* 159, pp. 132-139.
- Ashmore, M., Mulkay, M. and Pinch, T. 1989. *Health Efficiency: A Sociology of Health Economics*. London: Open University Press.
- Association for Inherited Cardiac Conditions (AICC). 2015. *Specialists* [online]. Available at: <http://www.aicc-uk.co.uk/specialists> (Accessed: 06/03/2015)
- Atkinson, M. 1978. *Discovering Suicide: Studies in the Social Organisation of Sudden Death*. Basingstoke: Macmillan Press.
- Atkinson, P. 1983. 'The Reproduction of the Professional Community' In: Dingwall, R. and Lewis, P. eds. *The Sociology of the Professions: Lawyers, Doctors and Others*. London: Macmillan, pp. 177-190.
- Atkinson, P., Delamont, S., Coffey, A., Loflant, J. and Lofland, L. 2001. *Handbook of Ethnography*. Thousand Oaks: Sage.

- Ballantyne, A. 2010. How to do research fairly in an unjust world. *The American Journal of Bioethics* 10(6), pp. 26-35.
- Beck, U. 1986. *Risk Society: Towards a New Modernity*. Thousand Oaks: SAGE.
- Becker, H. and Strauss, A. 1956. Careers, Personality and Adult Socialization. *American Journal of Sociology* 62(3), pp. 253-263.
- Becker, H. and Geer, B. 1957. Participant Observation and Interviewing: A Comparison. *Human Organization* 16(3), pp. 28-32.
- Becker, H., Geer, B., Hughes, E. and Strauss, A. 1961. *Boys in White: Student Culture in Medical School*. Chicago: University of Chicago Press.
- Beckwith, B.J. The Sudden Infant Death Syndrome. *Current Problems in Paediatrics* 3(8), pp. 3-36.
- Behr, E., Casey, A., Sheppard, M., Wright, M., Bowker, T.J., Davies, M.J., McKenna, W.J. and Wood, D.A. 2007. Sudden Arrhythmic Death Syndrome: A National Survey of Sudden Unexplained Cardiac Death. *Heart* 93(5), pp. 601-605.
- Behr, E. et al. 2015. Role of Common and Rare Variants in *SCN10A*: Results from the Brugada Syndrome QRS Locus Gene Discovery Collaborative Study. *Cardiovascular Research* 106(3), pp. 520-529.
- Bloor, M. 1991. The Minor Office: the Variable and Socially Constructed Character of Death Certification in a Scottish City. *Journal of Health and Social Behaviour*. 32(3), pp. 273-287.
- Blow, N. 2007. Tissue Preparation: Tissue Issue. *Nature* 448, pp. 959-962.
- Bonn, D. 2005. Genetics Knowledge Parks. *The Lancet Oncology* 6(6), pp. 366.
- Bosk, C. 1979. *Forgive and Remember: Managing Medical Failure*. Chicago: Chicago University Press.

- Bosk, C. 2007. When Life Fails to Imitate Art: Evidence-Based Therapy and the Bar to Innovation. In: *Governing Medical Research and Medical Practice: What is the Difference? ESRC Science and Society Workshop, 18<sup>th</sup> January 2007. Churchill Room, Goodenough College.*
- Bossuyt, P., Reitsma, J., Linnet, K. and Moons, K. 2012. Beyond Diagnostic Accuracy: The Clinical Utility of Diagnostic Tests. *Clinical Chemistry* 58(12), pp. 1636-1643.
- Bourret, P., Keating, P. and Cambrosio, A. 2011. Regulating Diagnosis in Post-Genomic Medicine: Re-Aligning Clinical Judgement? *Social Science and Medicine* 73, pp. 816-824.
- Bowker, G. and Star, S.L. 1999. *Sorting Things Out: Classification and Its Consequences.* Cambridge Massachusetts: MIT Press.
- Brent LB, Aburano A, Fisher DL, Moran TJ, Myers JD, Taylor WJ. 1960. Familial muscular subaortic stenosis: an unrecognized form of "idiopathic heart diseases", with clinical and autopsy observations. *Circulation* 21, pp. 167-180.
- Brickey, S., and Miller, D. 1975. Bureaucratic Due Process: An Ethnography of Traffic Court. *Social Problems* 22(5), pp. 688-697.
- Brown, P. 1994. Naming and Framing: The Social Construction of Diagnosis and Illness. *Journal of Health and Social Behaviour* 35(Extra Issue: Forty Years of Medical Sociology), pp. 34-52.
- Bucher, R. and Strauss, A.L. 1961. Professions in Process. *American Journal of Sociology* 66, pp. 324-334.
- Burton, J.L. and Wells, M. 2001. The Alder Hey Affair: Implications for Pathology Practice. *Journal of Clinical Pathology* 54, pp. 820-823.

- Burton, H. 2003. *The Cambridge Genetics Knowledge Park*. Cambridge Network [online]. Available at: <https://www.cambridgenetwork.co.uk/news/the-cambridge-genetics-knowledge-park/> (Accessed: 09/03/15).
- Burton, H., Alberg, C. and Stewart, A. 2009. *Heart to Heart: Inherited Cardiovascular Conditions Services: A needs Assessment and Service Review*. PHG Foundation.
- Cambrosio, A., Keating, P., Schlich, T. and Weisz, G. 2006. Regulatory Objectivity and the Generation and Management of Evidence in Medicine. *Social Science and Medicine* 63, pp. 189-199.
- Cardiac Risk in the Young (CRY). 2015a. *The Events Allowing the Re-opening of the Inquest into the Death of Lisa Jane Brown: As Told by her Mother, Doreen Harley* [online]. Available at: <http://www.c-r-y.org.uk/the-events-allowing-the-re-opening-of-the-inquest-into-the-death-of-lisa-jane-brown/> (Accessed: 20/12/2015)
- Cardiac Risk in the Young (CRY). 2015b. *Statement for the Inquest of Lisa Jane Brown, By Dr. Elijah R Behr* [online]. Available at: <http://www.c-r-y.org.uk/statement-for-the-inquest-of-lisa-jane-brown-by-dr-elijah-r-behr/> (Accessed: 20/02/2015).
- Challen, K., et al. 2005. Genetic Education and Non-Genetic Health Professionals: Education Providers and Curricula in Europe. *Genetics in Medicine* 7(1), pp. 302-310.
- Charmaz, K. 1976. The Coroner's Strategies for Announcing Death. In: Loftland, L. ed. *Toward a Sociology of Death and Dying*. California: Sage. pp. 296-316.
- Chen, J. and Chien, K. 1999. Complexity in Simplicity: Monogenic Disorders and Complex Cardiomyopathies. *Journal of Clinical Investigation* 103(11), pp. 1483-1485.
- Chen, Q. et al. 1998. Genetic basis and molecular mechanism for idiopathic ventricular fibrillation. *Nature*.392, pp. 293-296.

- Chen, H. 2009. Stem Cell Governance in China: From Bench to Bedside? *New Genetics and Society* 28(3), pp. 267-282.
- Christiaans, I., van Langen, I.M., Birnie, E., Bonsel, G.J., Wilde, A.A. and Smets, E.M. 2009. Genetic Counselling and Cardiac Care in Predictively Tested Hypertrophic Cardiomyopathy Mutation Carriers: The Patients' Perspective. *American Journal of Medical Genetics* 149A, pp. 1444-1451.
- Clarke, A. and Fujimura, J.H. 1992. *The Right Tools for The Job: At Work in Twentieth-Century Life Sciences*. New Jersey. Princeton University Press.
- Clarke, A. and Griesemer, J. 1989. Institutional Ecology, 'Translations' and Boundary Objects: Amateurs and Professionals in Berkeley's Museum of Vertebrate Zoology, 1907-39. *Social Studies of Science* 19(3), pp. 387-420.
- Clarke, A. 2003. Situational Analysis: Grounded Theory Mapping After the Postmodern Turn. *Symbolic Interaction* 26(4), pp. 553-576.
- Clarke, A. and Star, S.L. 2008. 'The Social Worlds Framework: A Theory/Methods Package'. In: Lynch, M., Amsterdamska, O. and Hackett, E. eds. *The New Handbook of Science and Technology Studies*. 3<sup>rd</sup> ed. Cambridge MA. MIT Press. pp. 113-137
- Clifford, J. and Marcus. 1986. *Writing Culture: The Poetics and Politics of Ethnography*. California: University of California Press.
- Cohrs, R., Martin, T., Ghahramani, P., Bidaut, L., Higgins, P. and Shahzad, A. 2015. Translational Medicine Definition by the European Society for Translational Medicine. *New Horizons in Translational Medicine* 2(3), pp. 86-88.
- Conrad, P. 1975. The Discovery of Hyperkinesis: Notes on the Medicalization of Deviant Behaviour. *Social Problems* 23(1), pp. 12-21.

Collins, H. 1981. The Place of the Core-Set in Modern Science: Social Contingency with Methodological Propriety in Science. *History of Science* 19(1), pp. 6-19.

Collins, H. 2004. *Gravities Shadow: The Search for Gravitational Waves*. Chicago: University of Chicago Press.

Collins, H. and Evans, R. 2002. The Third Wave of Science Studies. *Social Studies of Science* 32(2), pp. 235-296.

Collins, H. and Pinch, T. 2005. *Dr. Golem: How to think about Medicine*. Chicago: University of Chicago Press.

*The Coroners Rules, 1984. Rule 36.*

*The Coroners (Amendment) Rules, 2008. Rule 23.*

*The Coroners and Justice Act 2009.*

*The Coroners Allowances, Fees and Expenses Regulations 2013.*

*The Coroners (Inquest) Rules 2013.*

Dalton, A.J. 1994. To Speak for the Dead to Protect the Living. *The Lancet* 344(8933), pp. 1367-1368.

Daston, L. and Galison, P. 1992. The Image of Objectivity. *Representations* 40(1), pp. 81-128.

Davies, M. 1992. Unexplained Death in Fit young People: A Category of Sudden Unexpected Death Syndrome is Needed. *British Medical Journal* 305(6853), pp. 538-539.

Davies, P. 2001. Spies as Informants: Triangulation and the Interpretation of Elite Interview Data in the Study of the Intelligence and Security Services. *Politics* 21(1), pp. 73-80.



- Department of Health, 2002. *Confidentiality: NHS Code of Practice*. Department of Health.
- Department of Health. 2003. *Our Inheritance, our Future – Realising the Potential of Genetics in the NHS*. Department of Health.
- Department of Health. 2016. *Introduction of Medical Examiners and Reforms to Death Certification in England and Wales: Policy and Draft Regulations*. Department of Health.
- Department of Health Coronary Heart Disease Team. 2005. *National Service Framework for Coronary Heart Disease – Chapter Eight: Arrhythmias and Sudden Cardiac Death*. Department of Health.
- Dewar, S. and Boddington, P. 2004. Returning to the Alder Hey Report and its Reporting: Addressing Confusions and Improving Enquiries. *Journal of Medical Ethics* 30, pp. 463-469.
- Dingwall, R. 1984. 'Introduction'. In: Dingwall, R. and Lewis, P. eds. *The Sociology of the Professions: Lawyers, Doctors and Others*. London: Macmillan, pp. 1-12.
- Douglas, J. 1967. *The Social Meaning of Suicide*. Princeton: Princeton University Press.
- Easter, M., Henderson, G., Davis, A., Churchill, L., and King, N. 2006. The Many Meanings of Care in Clinical Research. *Sociology of Health and Illness* 28(6) pp. 695-672.
- Edward, W.D. 2005. Molecular Autopsy vs Post Mortem Genetic Testing. *Mayo Clinical Proceedings* 80(9), pp. 1234-1235.
- Edwards, P.N., Mayernik, M.S., Batcheller, A.L., Bowker, G.C. and Borgman, C.L. 2011. Science Friction: Data, Metadata and Collaboration. *Social Studies of Science*. 41(5), pp. 667-690.
- Emerson, R., Fretz, R. and Shaw, L. 2011. *Writing Ethnographic Fieldnotes*. 2<sup>nd</sup> ed. Chicago: University of Chicago Press.

- Epstein, S. 1993. *Impure Science: AIDS, Activism, and the Politics of Knowledge*. California: University of California Press.
- Fincham, B., Langer, S., Scourfield, J., and Shiner, M. 2011. *Understanding Suicide: A Sociological Autopsy*. Basingstoke: Palgrave Macmillan.
- Fisher, J. 2008. Practicing Research Ethics: Private-Sector Physicians and Pharmaceutical Clinical Trials. *Social Science and Medicine* 66, pp. 2495-2505.
- Fisher, J. 2015. Feeding and Bleeding: The Institutional Banalization of Risk to Healthy Volunteers in Phase 1 Pharmaceutical Clinical Trials. *Science, Technology and Human Values* 40(2), pp. 199-226.
- Forrest, K., Simpson, S., Wilson, B., van Teijlingen, E., McKee, L., Haites, N. and Matthews, E. 2003. To Tell or Not to Tell: Barriers and Facilitators in Family Communication about Genetic Risk. *Clinical Genetics* 64, pp. 317-326.
- Foucault, M. 1977. *Discipline and Punish: The Birth of the Prison*. New York: Vintage Books.
- Foucault, M. 1963. *The Birth of the Clinic*. Paris: Presses Universitaires de France.
- Foucault, M. 1980. Truth and Power. In: C. Gordon. ed. *Power/Knowledge: Selected Interviews and other Writings 1972-1977*. Sussex: Harvester Press.
- Fox, R. 1959. *Experiment Perilous: Physicians and Patients Facing the Unknown*. Transaction Publishers: New Jersey.
- Freidson, E. 1970a. *Profession of Medicine: A Study of the Sociology of Applied Knowledge*. Chicago: Chicago University Press.
- Freidson, E. 1970b. *Professional Dominance: The Social Structure of Medical Care*. Chicago: Chicago University Press.

Freidson, E. 1983. 'The Theory of Professions: State of the Art'. In: Dingwall, R. and Lewis, P. eds. *The Sociology of Professions: Lawyers, Doctors and Others*. London: Macmillan, pp. 13-28.

Friedson, E. 1987. *Professional Powers: A Study of the Institutionalization of Formal Knowledge*. Chicago: Chicago University Press.

Freidson, E. 1994. *Professionalism Reborn: Theory, Prophecy and Policy*. Chicago: Chicago University Press.

Freidson, E. 2001. *Professionalism: The Third Logic*. Chicago: Chicago University Press.

Fujimura, J. 1996. *Crafting Science: A Sociohistory of the Quest for the Genetics of Cancer*. Cambridge, Mass: Harvard University Press.

Galison, P. 1997. *Image and Logic: A Material Culture of Microphysics*. Chicago: University of Chicago Press.

Garfinkel, H. 1967. *Studies in Ethnomethodology*. New Jersey: Prentice Hall.

Garratt, C et al. 2008. Clinical Indications for Genetic Testing in Familial Sudden Cardiac Death Syndrome: An HUK Statement. *Heart* 94(4), pp. 502-507.

Geelen, E., Van Hoyweghen, I. and Horstman, K. 2011. Making Genetics not so Important: Family Work in Dealing with Familial hypertrophic Cardiomyopathy. *Social Science and Medicine* 72, pp. 1752-1759.

General Medical Council, 2009. *Confidentiality*. General Medical Council.

General Medical Council, 2015. *Outcomes for Graduates (Tomorrows Graduates)*. General Medical Council.

Genomics England. 2015a. *The 100,000 Genomes Project Protocol*. Genomics England.

Genomics England, 2015b. *Rare Diseases Eligibility Statements: 100,000 Genomes Project*.  
Genomics England.

Gibbons, M. et al. 1994. *The New Production of Knowledge: The Dynamics of Science and Research in Contemporary Society*. Thousand Oaks: SAGE.

Giddens, A. 1991. *Modernity and Self-Identity: Self and Society in the Late Modern Age*.  
Stanford: Stanford University Press.

Gieryn, T. 2002. What Buildings Do. *Theory and Society* 31(1), pp. 35-74.

Glaser, B. and Strauss, A. 1976. *The Discovery of Grounded Theory: Strategies for Qualitative Research*. Chicago: Aldine Publishing Company.

Goffman, E. 1959. *The Presentation of Self in Everyday Life*. New York: Random House.

Goffman, E. 1989. On Fieldwork. *Journal of Contemporary Ethnography* 18, pp. 123-32.

Goode, W. 1957. Community within a Community: The Professions. *American Sociological Review* 22(2), pp. 194-200.

Gubrium, J. and Lynott, R.J. 1985. Family Rhetoric as Social Order. *Journal of Family Issues* 6, pp. 129-152.

Hacking, I. 1990. *The Taming of Chance*. Cambridge: Cambridge University Press.

Hall, E. 2005. The 'Geneticization' of Heart Disease: A Network Analysis of the Production of New Genetic Knowledge. *Social Science and Medicine* 60(12), pp. 2673-2683.

Hallowell, N., Cooke, S., Crawford, G., Lucassen, A., and Parker, M. 2009. Distinguishing Research from Clinical Care in Cancer Genetics: Theoretical Justifications and Spatial Strategies. *Social Science and Medicine* 68, pp. 2010-2017.

- Hallowell, N., Cooke, S., Crawford, G., Lucassen, A., Parker, M. and Snowdon, C. 2010. An Investigation of Patients Motivations for their Participation in Genetics-related Research. *Journal of Medical Ethics* 36, pp. 37-45.
- Hallowell, N., Hall, A., Alberg, C., and Zimmern, R. 2015. Revealing the Results of Whole-Genome Sequencing and Whole-Exome Sequencing in Research and Clinical Investigations: Some Ethical Issues. *Journal of Medical Ethics* 41, pp. 317-321.
- Hanzlick, R. 2006. Medical Examiners, Coroners and Public Health. *Archives of Pathology and Laboratory Medicine* 130, pp. 1274-1282.
- Heath, C. 1984. Review Essay: Everett Cherrington Hughes (1897-1983). *Sociology of Health and Illness* 6(2), pp. 218-237.
- Hedgecoe, A. 2000. *Narratives of Geneticization: Cystic Fibrosis, Diabetes and Schizophrenia*. PhD Thesis: University of London.
- Hedgecoe, A. 2001. Schizophrenia and the Narrative of Enlightened Geneticization. *Social Studies in Science* 31(6), pp. 875-911.
- Hedgecoe, A. 2004. *The Politics of Personalised Medicine – Pharmacogenetics in the Clinic*. Cambridge: Cambridge University Press.
- Hedgecoe, A. 2006. It's Money that Matters: The Financial Context of Ethical Decision-Making in Modern Biomedicine. *Sociology of Health and Illness* 28(6), pp. 768-784.
- Hedgecoe, A. 2008. From Resistance to Usefulness: Sociology and the Clinical Use of Genetic Testing. *BioSocieties* 3, pp. 183-194.
- Henderson, G.E., Easter, M.E., Zimmer, C., King, N.M., Davis, A.M., Bluestone Rothschild, B., Churchill, L.R., Wilford, B.S. and Nelson, D.K. 2006. Therapeutic Misconception in Early Phase Gene Transfer Trials. *Social Science and Medicine* 62(1), pp. 239-253.

- Hershberger, R., Hedges, D. and Morales. 2013. Dilated Cardiomyopathy: The Complexity of a Diverse Genetic Architecture. *Nature Reviews Cardiology* 10(9), pp. 531-547.
- Higgs, E. 2001. The Rise of the Information State: The Development of Central State Surveillance of the Citizen in England, 1500-2000. *Journal of Historical Sociology* 14(2), pp. 175-197.
- Hintsala, T., Keltikangas-Jarvinen, L., Puttonen, S., Ravaja, N., Toivonen, L., Kontula, K. and Swan, H. 2009. Depressive Symptoms in the Congenital Long QT Syndrome. *Annals of Medicine* 41, pp. 516-521.
- Hollands, G.J., Armstrong, D., Macfarlane, A., Crook, M.A., and Marteau, T. 2012. Patient Accounts of Diagnostic Testing for Familial Hypercholesterolaemia: Comparing Responses to Genetic and Non-Genetic Testing Methods. *BMC Medical Genetics* 13 (87), pp. 1-9.
- Hollman, A., Goodwin, J., Teare, D. and Renwick, J. 1960. A Family with Obstructive Cardiomyopathy (Asymmetrical Cardiomyopathy). *British Heart Journal* 22(4), pp. 449-456.
- Hu, D. et al 2014. Mutations in SCN10A are responsible for a large fraction of cases of Brugada syndrome. *Journal of the American College of Cardiology* 64(1), pp. 66-79.
- Hughes, D. and Griffiths, L. 1997. "Ruling in" and "Ruling Out": Two Approaches to the Micro-Rationing of Health Care. *Social Science and Medicine* 44(5), pp. 589-599.
- Hughes, E. 1958. *Men and Their Work*. London: Collier-Macmillan.
- Hughes, E. 1971. *The Sociological Eye: Selected Papers*. New Brunswick: Transaction Books.
- Human Tissue Act 2004*.
- Jarcho, J.A., McKenna, W., Pare, P., Solomon, S.D., Holcombe, R.F., Dickie S., Levi, T., Donis-Keller, H., Seidman, J.G., and Seidman, C.E. 1989. Mapping a Gene for Familial Hypertrophic

Cardiomyopathy to Chromosome 14q1. *New England Journal of Medicine* 321, pp. 1372-1378.

Jasanoff, S. 1995. *Science at the Bar: Law, Science and Technology in America*. Cambridge: Mass. Harvard University Press.

Jasanoff, S. 2003. Breaking the Waves in Science Studies: Comment on H.M. Collins and Robert Evans, 'The Third Wave of Science Studies'. *Social Studies of Science* 33(3), pp. 389-400.

Jasanoff, S. 2006. Just Evidence: The Limits of Science in the Legal Process. *Journal of Law, Medicine and Ethics*. 34(2), pp. 328-341.

Jasanoff, S. 2008. Representations and Re-Presentations in Litigation Science. *Environmental Health Perspectives* 116(1), pp. 123-129.

Jerolmack, C. and Kahn, S. 2014. Talk is Cheap: Ethnography and the Attitudinal Fallacy. *Sociological Research Methods* 43(2), pp. 178-209.

Joint Committee on Pathology Training. 2010. *Curriculum for Specialist Training in Histopathology*. The Royal College of Pathologists.

Jutel, A. and Nettleton, S. 2011. Towards a Sociology of Diagnosis: Reflections and Opportunities. *Social Science and Medicine* 73(6), pp. 793-800.

Kaye, J., Bell, J., Briceno, L. and Mitchell, C. 2016. Biobank Report: United Kingdom. *The Journal of Law, Medicine and Ethics* 44, pp. 96-105.

Katz, M. and Rosen, H. 1991. *Microeconomics*. New York: Irwin.

Kelly, A., Ameli, D., Majaimbere, S., Lindsay, S., and Pinder, M. 2010. Like Sugar and Honey: the embedded ethics of a larval control project in the Gambia. *Social Science and Medicine* 70, pp. 1912-1919.

- Klein, R. 2010. *The New Politics of the NHS: From Creation to Reinvention* (6<sup>th</sup> Edition). Milton Keynes: Radcliffe Publishing.
- Klein, R., Day, P. and Redmayne, S. 1996. *Managing Scarcity: Priority Setting and Rationing in the National Health Service*. Milton Keynes: Open University Press.
- Klinenberg, E. 2002. *Heat Wave: A Social Autopsy of Disaster in Chicago*. Chicago: Chicago University Press.
- Klitzman, R. 2010. Exclusion of Genetic Information from the Medical Record. *Journal of the American Medical Association* 304(10), pp. 1120-1121.
- Knorr-Cetina, K. 1999. *Epistemic Cultures: How the Sciences Make Knowledge*. Cambridge, Mass: Harvard University Press.
- Kohli-Laven, N., Bourret, P., Keating, P., Cambrosio, A. 2011. Cancer Clinical Trials in the Era of Genomic Signatures: Biomedical Innovation, Clinical Utility, and Regulatory Scientific Hybrids. *Social Studies of Science* 41(4), pp. 487-513.
- Komatsu, H. and Yagasaki, K. 2014. Are We Ready for Personalised Cancer Risk Management? The View From Breast-care Providers. *International Journal of Nursing Practice* 20, pp. 39-45.
- Kuhn, T. 1962. *The Structure of Scientific Revolutions*. Chicago: University of Chicago Press.
- Khushf, G. 1999. The aesthetics of clinical judgement: exploring the link between diagnostic elegance and effective resource utilization. *Medicine, Health Care and Philosophy* 2, pp. 141-159.
- Lahsen, 2005. Seductive Simulations? Uncertainty Distribution around Climate Models. *Social Studies in Science* 35(6), pp. 895-922.



- Larson, M.S. 1977. *The Rise of Professionalism: A Sociological Analysis*. California: University of California Press.
- Latimer, J. 2013. *The Gene, the Clinic and the Family: Diagnosing Dysmorphology, Reviving Medical Dominance*. London: Routledge.
- Latimer, J., Featherstone, K., Atkinson, P., Clarke, A., Pilz, D. and Shaw, A. 2006. Rebirthing the Clinic: The Interaction of Clinical Judgement and Genetic Technology in the Production of Medical Science. *Science Technology and Human Values* 31(5), pp. 599-630.
- Latour, B. and Woolgar. 1979. *Laboratory Life: The Construction of Scientific Facts*. New Jersey: Princeton University Press.
- Latour, B. 2005. *Reassembling the Social: An Introduction to Actor-Network Theory*. Oxford: Oxford University Press.
- Latour, B. 2010. *The Making of Law: An Ethnography of the Conseil D'Etat*. Cambridge: Polity Press.
- Latour, B. 2004. Scientific Objects and Legal Objectivity. In: Pottage, A. and Mundy, M. eds. *Law, Anthropology and the Constitution of the Social: Making Persons and Things*. Cambridge: Cambridge University Press. pp. 73-114.
- Law, J. 1987. 'Technology and Heterogeneous Engineering: The Case of Portuguese Expansion' In: Bijker, W., Hughes, T. and Pinch. T. eds). *The Social Construction of Technological Systems: New Directions in the Sociology and History of Technology*. Massachusetts: MIT Press. pp. 111-134.
- Leadbeater, S., Lucas, S. and Lowe, J. 2014. *Standards for Coroners' Pathologists in Post-mortem Examinations of Deaths that Appear not to be Suspicious*. The Royal College of Pathologists.

- Leslie, M. 2012. *Speaking for the Dead: Coroners, Institutional Structures and Risk Management*. PhD Thesis. University of Toronto.
- Levin, N. 2014. Multivariate Statistics and the Enactment of Metabolic Complexity. *Social Studies of Science* 44(4), pp. 555-578.
- Liberati, E., Gorli, M. and Scaretti, G. 2016. Invisible Walls within Multidisciplinary Teams: Disciplinary Boundaries and their Effects on Integrated Care. *Social Science and Medicine* 150, pp. 31-39.
- Lidz, C.W. 2009. Therapeutic Misconception and the Limits of Ethnography: A Commentary on Timmermans and McKay. *Social Science and Medicine* 69(12), pp. 1791-1792.
- Lippman, A. 1991. Prenatal Genetic Testing and Screening: Constructing Needs and Reinforcing Inequalities. *American Journal of Law and Medicine* 17(1and2), pp. 15-50.
- Lock, M. 2002. *Twice Dead: Organ Transplantation and the Re-invention of Death*. California: University of California Press.
- Lui, L. 2014 [1983]. 'Foreword' in: R. Dingwall and P. Lewis. eds. *The Sociology of the Professions: Lawyers, Doctors and Others*. London: Macmillan, pp. iii-ix.
- Lynch, M. and Jasanoff, S. 1998. Contested Identities: Science, Law and Forensic Practice. *Social Studies of Science* 28(5-6), pp. 675-686.
- Lynch, M. and Cole, S. 2005. Science and Technology Studies on Trial: Dilemmas of Expertise. *Social Studies of Science* 35(2), pp. 269-311.
- MacKenzie, D. 1990. *Inventing Accuracy: A Historical Sociology of Nuclear Missile Guidance*. Cambridge: MA. MIT Press.

- MacKenzie, D. 2006. *An Engine, not a Camera: How Financial Models Shape Markets*. Cambridge Massachusetts: MIT Press.
- MacKenzie, D. and Spears, T. 2012. 'The Formula That Killed Wall Street'? The Gaussian Copola and the Material Cultures of Modelling. *Social Studies of Science*. 44(3), pp. 393-417.
- Marris, E. 2005. Unchecked By Government, Genetic Tests Sell Hope and Hype. *Nature Medicine* 11(6), pp. 584.
- Martin, P. 2001. Genetic Governance: The Risks, Oversight and Regulation of Genetic Databases in the UK. *New Genetics and Society* 20(2), pp. 157-183.
- Martin, P., Brown, N., Kraft, A. 2008. From Bench to Bedside? Communities of Promise, Translational Research and the Making of Blood Stem Cells. *Science as Culture* 17(1), pp. 29-41.
- Matthews, P. 2014. *Jervis on Coroners*. 13<sup>th</sup> ed. London: Sweet and Maxwell.
- McCormick, J., Green, M.W., Mehta, G., Culross, F. and Mehta, A. 2002. Demographics of the UK Cystic Fibrosis Population: Implications for Neonatal Screening. *European Journal of Human Genetics* 10, pp. 583-590.
- McKee, M. and Healy, J. 2002. *Hospitals in Changing Europe*. Buckingham: Open University Press.
- McKenna, W., Thiene, G., Nava, A., Fontaliran, F., Blomstrom-Ludqvist, C., Fontaine, G. and Camerini, F. 1994. Diagnosis of Arrhythmogenic Right Ventricular Dysplasia/Cardiomyopathy. *British Heart Journal* 71, pp. 215-218.
- McKenna et al. 2007. *Proposal for the Establishment of Inherited Cardiovascular Conditions Centres*. An Unattributed Informal Advisory Group.

- McNeil, K., Mitchell, R. and Parker. 2013. Interprofessional Practice and Professional Identity Threat. *Health Sociology Review* 22(3), pp. 291-307.
- Medical Research Council (MRC). 2008. *Medical Research Council: Annual Report and Accounts 07/08*. London: The Stationary Office.
- Merton, RK. 1942. *The Sociology of Science: Theoretical and Empirical Investigations*. Chicago: Chicago University Press.
- Merton, R.K., Reader, G. and Kendall, P.L. 1957. *The Student Physician: Introductory Studies in the Sociology of Medical Education*. Cambridge Massachusetts: Harvard University Press.
- Mikecz, R. 2012. Interviewing Elites: Addressing Methodological Issues. *Qualitative Enquiry* 18(6), pp. 482-493.
- Miller, F., Giacomini, M., Ahern, C., Robert, J. and de Laat, S. 2008. When Research seems like Clinical Care: A Qualitative Study of the Communication of Individual Cancer Genetic Research Results. *BMC Medical Ethics* 9(4), pp. 1-12.
- Ministry of Justice, 2015. *Coroners Statistics, 2014*. Ministry of Justice. London: HMSO.
- Moore, J. 2016. *Coroners' Recommendations and the Promise of Saved Lives*. Cheltenham: Edward Elgar.
- Mol, A. 2002. *The Body Multiple: Ontology in Medical Practice*. Durham: Duke University Press.
- Nader, L. 1972. 'Up the Anthropologist: Perspectives Gained from Studying Up' In: Hymes, D. ed. *Reinventing Anthropology*. New York: Pantheon Books, pp. 284-311.
- Nancarrow, S. and Borthwick, A. 2005. Dynamic Professional Boundaries in the Healthcare Workforce. *Sociology of Health and Illness* 27(7), pp. 897-919.

- NCEPOD, 2006. *The Coroner's Autopsy: Do We Deserve Better? –A report of the National Confidential Enquiry into Patient Outcome and Death*. NCEPOD
- NHS England. 2013a. *Integrated Care: Our Shared Commitment*. Department of Health.
- NHS England. 2013b. *Who Pays? Determining Responsibility for Payment to Providers*. NHS England.
- NHS England. 2013c. *A09/S/c: 2013/2014 NHS Standard Contract for Cardiology: Inherited Cardiac Conditions (All Ages)*. NHS England.
- NHS Wales. 2011. *All Wales Policy: Making Decisions on Individual Patients Funding Requests*. NHS Wales.
- Office for National Statistics, 2015. *Statistical Bulletin – Deaths Registered in England and Wales (Series DR), 2014*. Office for National Statistics.
- Oh, H. 2014a. *Your Money of Your Life: How Doctors Learn the Business of Health*. PhD Thesis: UCLA.
- Oh, H. 2014b. Hospital Consultations and Jurisdiction over Patients: Consequences for the Medical Profession. *Sociology of Health and Illness* 36(4), pp. 580-595.
- Oudshoorn, N., and Pinch, T. 2003. *How Users Matter: The Co Construction of Users and Technology*. Cambridge Massachusetts: MIT Press.
- Papadakis, M., Sharma, S., Cox, S., Sheppard, M., Panoulas, V.F. and Behr, E. 2009. The Magnitude of Sudden Cardiac Death in the Young: A Death Certificate-based Review. *Europace* 11(10), pp. 1353-1358.
- Pare JA, Fraser RG, Pirozynski WJ, Shanks JA, Stubington D. 1961. Hereditary cardiovascular dysplasia: A form of familial cardiomyopathy. *American Journal of Medicine* 31, pp. 37-62.

- Parker, M., Ashcroft, R., Wilkie, A.O. and Kent, A. 2004. Ethical Review of Research into Rare Genetic Disorders. *British Medical Journal* 329(7460), pp. 288-289.
- Pescosolido, B. and Mendelsohn, R. 1986. Social Causation or Social Construction of Suicide? An Investigation into the Social Organisation of Official Rates. *American Sociological Review* 51(1), pp. 80-100.
- Petryna, A. 2007. Clinical Trials Offshored: On Private Sector Science and Public Health. *Biosocieties* 2, pp. 21-40.
- Petryna, A. 2009. *When Experiments Travel: Clinical Trials and The Global Search for Human Subjects*. New Jersey. Princeton University Press.
- Pifer, NA. 2015. The Scientific and the Social in Implementing *Atkins v. Virginia*. *Law and Social Enquiry*. [Online First].
- Pinch, T. and Bijker, W. 1984. The Social Construction of Facts and Artefacts: Or How the Sociology of Science and the Sociology of Technology Might Benefit Each Other. *Social Studies of Science* 14, pp. 399-441.
- Pinch, T., Ashmore, M. and Milkay, M. 1992. 'Technology, Testing, Text: Clinical Budgeting in the U.K. National Health Service. In: W. Bijker and J. Law. eds. *Shaping Technology/Building Society: Studies in Sociotechnical Change*. Cambridge, Mass: The MIT Press, pp. 265-289.
- Pounder, D., Jones, M. and Peschel, H. 2011. How can we Reduce the Number of Coroner Autopsies? Lessons from Scotland and the Dundee Initiative. *Journal of The Royal Society of Medicine* 104(1), pp. 19-24.
- Porter, T. 1995. *Trust in Numbers*. Princeton University Press.

- Priaulx, N. And Weinel, M. 2014. Behaviour on a Beer Mat: Law, Interdisciplinarity and Expertise. *Journal of Law, Technology and Policy* 2014(2), pp. 361-391.
- Priaulx, N., Weinel, M. and Goldsworthy, C. 2016. Bolitho: Law, Medicine and Expertise. In: Coggon, J., McGuinness, S., Huxtable, R., Hobson, C., Smith, S., Miola, J. and Neal, M. eds. *Ethical Judgements: Rewriting Medical Law*. Oxford: Hart Publishing.
- Prior, L. 1985a. Making Sense of Mortality. *Sociology of Health and Illness* 7(2), pp. 167-190.
- Prior, L. 1985b. The Good, the Bad and the Unnatural: A Study of Coroners' Decisions in Northern Ireland. *The Sociological Review*. 33(1), pp. 64-90.
- Prior, L. 1987. Policing The Dead: A Sociology of the Mortuary. *Sociology* 21(3), pp. 355-376.
- Prior, L. 1989. *The Social Organisation of Death: Medical Discourse and Social Practices in Belfast*. Houndsmill: The MacMillan Press.
- Prior, L. 2001. Rationing through risk assessment in clinical genetics: all categories have wheels. *Sociology of Health and Illness* 23(5) pp. 570-593.
- Priori, S. et al. 2013. HRS/EHRA/APHRs Expert Consensus Statement on the Diagnosis and Management of Patients with Inherited Primary Arrhythmia Syndromes. *Heart Rhythm* 10(12), pp. 1932-1963.
- Purchase, W and Woollaston, H. 1957. *Jervis: On the Office and Duties of the Coroner*. 9<sup>th</sup> ed. London: Sweet and Maxwell.
- Rabeharisoa, V. and Bourret, P. 2009. Staging and Weighting Evidence in Biomedicine. *Social Studies of Science* 39(5), pp. 691-715.
- The Registration of Births and Deaths Regulations, 1987*.

- Resnik, D. 2003. Genetic Testing and Primary Care: A New Ethic for a New Setting. *New Genetics and Society* 22(3), pp. 245-256.
- Reyes-Galindo, L. 2014. Linking Sub-cultures of Physics: Virtual Empiricism and the Bonding Role of Trust. *Social Studies of Science* 44(5), pp. 736-757.
- Ribeiro, R. 2007. The Role of Interactional Expertise in Interpreting: The Case of Technology Transfer in the Steel Industry. *Studies in the History and Philosophy of Science* 38(4), pp. 713-721.
- Rose, N. 2001. The Politics of Life Itself. *Theory, Culture and Society*. 18, pp. 1-30.
- Rose, N. 2013. The Human Sciences in a Biological Age. *Theory, Culture & Society* 30(1), pp. 3-34.
- Royal College of Pathologists. 2015. *Guidelines on Autopsy Practice: Sudden Death With Likely Cardiac Pathology*. Royal College of Pathologists.
- Royal College of Physicians, Royal College of Pathologists and British Society for Human Genetics. *Consent and confidentiality in clinical genetic practice: guidance on genetic testing and sharing genetic information*. 2<sup>nd</sup> ed. Report of the Joint Committee on Medical Genetics. London: RCP, RCPATH, 2011.
- Royal Liverpool Children's Enquiry. 2001. *Report: The Royal Liverpool Children's Enquiry*. London: The Stationary Office.
- Sanders, T. and Harrison, S. 2008. Professional Legitimacy Claims in the Multidisciplinary Workplace: The Case of Heart Failure Care. *Sociology of Health and Illness* 30(2), pp. 289-308.
- Scheffer, T. 2010. *Adversarial Case Making: An Ethnography of English Crown Court Procedure*. Leiden: Brill.



Schwartz, P., Moss, A., Vincent, G. and Crampton, R. 1993. Diagnostic Criteria for the Long QT Syndrome. An Update. *Circulation*.88(2), pp. 782-784.

Scottish intercollegiate Guidelines Network. 2008. *Diagnosis and Management of Headache in Adults: A National Clinical Guideline*. SIGN.

Scourfield, J., Fincham, B., Langer, S. and Shiner, M., 2012. Sociological Autopsy: An Integrated Approach to Understanding Suicide in Men. *Social Science and Medicine* 74(4), pp. 466-473.

Seale, C. 1998. *Constructing Death: The Sociology of Dying and Bereavement*. Cambridge: Cambridge University Press.

Seale, C., Cavers, D., Dixon-Woods, M., 2006. Commodification of Body Parts: By Medicine or by Media? *Body and Society* 12(1), pp. 25-42.

Semsarian, C. and Ingles, J. 2015. Molecular Autopsy of Victims of Inherited Arrhythmias. *Journal of Arrhythmia* [in press].

Shostak, S. 2005. The Emergence of Toxicogenomics: A Case Study of Molecularization. *Social Studies of Science* 35(3), pp. 367-403.

Simmel, G. 1950. 'The Stranger'. In: K. Wolff (Trans). *The Sociology of Georg Simmel*. New York: Free Press, pp. 402-408.

Smith, R. and Wynne, B. eds. 1989. *Expert Evidence: Interpreting Science in the Law*. London: Routledge.

Spitz, W.U. and Fisher, R.S. 1980. *Medicolegal Investigation of Death*. 2<sup>nd</sup> ed. Springfield, IL: Charles C Thomas.

Splawski, I. et al. 2000. Spectrum of mutations in long-QT syndrome genes: KVLQT1, HERG, SCN5A, KCNE1, and KCNE2. *Circulation* 102, pp. 1178-1185.

- Star, S.L. 2010. This is Not a Boundary Object: Reflections on the Origin of a Concept. *Science Technology and Human Values* 35(5), pp. 601-617.
- Stephens, N. 2013. Growing Meat in Laboratories: The Promise, Ontology, and Ethical Boundary-Work if Using Muscle Cells to Make Food. *Configurations* 21(2), pp. 159-181.
- Stephens, ZD., Lee, SY., Faghri, F., Campbell, RH., Zhai, C., Efron, MJ., Iyer, R., Schatz, M.C., Sinha, S. and Robinson, GE. 2015. Big Data: Astronomical or Genomical?. *PLOS Biology* 13(7), pp. 1-11.
- Sudnow, D. 1976. *Passing On: The Social Organization of Dying*. New Jersey: Prentice-Hall.
- Teare, D. 1958. Asymmetrical Hypertrophy of the Heart in Young Adults. *British Heart Journal* 20(1), pp. 1-8.
- te Riele, ASJM., Tandri, H. and Bluemke, DA. 2014. Arrhythmogenic Right Ventricular Cardiomyopathy (ARVC): Cardiovascular Magnetic Resonance Update. *Journal of Cardiovascular Magnetic Resonance* 16(50), pp. 1-15.
- Thomas, A.C., Knapman, P.A., Krikler, D.M. and Davies, M.J. Community Study of the Causes of "Natural" Sudden Death. *British Medical Journal* 297(6661), pp. 1453-1456.
- Thornton, P. 2014. *Chief Coroner: Joint Guidance for Coroners and Coroners' Officers: Sudden Cardiac Death: Inherited Heart Conditions*. Ministry of Justice.
- Timmermans, S. and Berg, M. 1997. Standardization in Action: Achieving Local Universality Through Medical Protocols. *Social Studies of Science* 27, pp. 273-305.
- Timmermans, S. 1998. Mutual Tuning of Multiple Trajectories. *Symbolic Interaction* 21(4), pp. 425-440.
- Timmermans, T. and Berg, M. 2003. *The Gold Standard: The Challenge of Evidence-Based Medicine and Standardization in Health Care*. Philadelphia: Temple University Press.

- Timmermans, S. 2005. Death Brokering: Constructing Culturally Appropriate Deaths. *Sociology of Health and Illness* 27(7), pp. 993-1013.
- Timmermans, S. 2008. Professions and their work: Do Market Shelters Protect Professional Interests? *Work and Occupations* 35(2), pp. 164-188.
- Timmermans, S. and McKay, T. 2009a. Clinical Trials as Treatment Option: Bioethics and Health Care Disparities in Substance Dependency. *Social Science and Medicine* 69(12), pp. 1784-1790.
- Timmermans, S and McKay, T. 2009b. The Bioethical Misconception: A Response to Lidz. *Social Science and Medicine* 69(12), pp. 1793-1796.
- Timmermans, S. 2010. 'Reconciling Research with Medical Care in RCT's.' In: Moriera, T. and Will, C. eds. *Medical Proofs, Social Experiments: Clinical Trials in Shifting Context*. Farnham: Ashgate, pp. 17-31.
- Timmermans, S. 2011. The Joy of Science: Finding Success in a "Failed" Randomized Control Trial. *Science Technology and Human Values* 36(4), pp. 549-572.
- Timmermans, S. and Tavory, I. 2012. Theory Construction in Qualitative Research: From Grounded Theory to Abductive Analysis. *Sociological Theory* 30(3), pp. 167-186.
- Timmermans, S. and Tavory, I. 2014. *Abductive Analysis: Theorizing Qualitative Research*. Chicago: University of Chicago Press.
- Timmermans, S. 2015. Trust in Standards: Transitioning Clinical Exome Sequencing from Bench to Bedside. *Social Studies in Science* 45(1), pp. 77-99.
- Timmermans, S. and Shostack, S. 2016. Gene Worlds. *Health (London)* 20(1), pp. 33-48.

- Timmons, S. and Tanner, J. 2004. A disputed Occupational Boundary: Operating Theatre Nurses and Operating Department Practitioners. *Sociology of Health and Illness* 26(5), pp. 645-666.
- The UK10K Consortium. 2015. The UK10K Project Identifies Rare Variants in Health and Disease. *Nature* 526, pp. 82-90.
- Van Hoyweghen, I. 2007. *Risks in the Making: Travels in Life Insurance and Genetics*. Amsterdam: Amsterdam University Press.
- Van Mannen, J. and Schein, E. 1979. Towards a Theory of Organizational Socialization. *Research in Organisational Behaviour* 1(1), pp. 209-264.
- Vavolizza, R., Kalia, I., Erskine Aaron, K., Silverstein, L., Barlevy, D., Wasserman, D., Walsh, C., Marion, R. and Dolan, S. 2015. Disclosing Genetic Information to Family Members About Inherited Cardiac Arrhythmias: An Obligation or Choice? *Journal of Genetics Counselling* 24, pp. 608-615.
- Wang, C., Schroeder, K., Rosenberg, N. 2012. A Maximum-Likelihood Method to Correct for Allelic Dropout in Microsatellite Data with No Replicate Genotypes. *Genetics* 192(2), pp. 651-669.
- Wainwright, S., Williams, C., Michael, M., Farsides, B. and Cribb, A. 2006. From Bench to Bedside? Biomedical Scientists' Expectations of Stem Cell Science as a Future Therapy for Diabetes. *Social Science & Medicine* 63(8), pp. 2052-2064.
- Watkins, W.J. and Sen-Chowdhry, S. 2008. From Teare to the Present Day: A Fifty Year Odyssey in Hypertrophic Cardiomyopathy, a Paradigm for the Logic of the Discovery Process. *Revista Española de Cardiología* 61(12) pp. 1239-1244.
- Watts, G. 2010. Lost Without Translation? *British Medical Journal* 341, pp. c4363.

- Weiner, K. and Martin, P. 2008. A Genetic Future for Coronary Heart Disease? *Sociology of Health and Illness* 30(3), pp. 380-395.
- Wales Health Specialist Services Committee, 2012. *Specialist Service Policy CP57: Genetic Testing for Inherited Cardiac Conditions*. WHSSC.
- Will, C. 2011. Mutual Benefit, Added Value? Doing Research in the National Health Service. *Journal of Cultural Economy* 4(1), pp. 11-26.
- Will, C., Armstrong, D., Marteau, T. 2010. Genetic Unexceptionalism: Clinician Accounts of Genetic Testing for Familial Hypercholesterolemia. *Social Science and Medicine* 71(5), pp. 910-917.
- Wilson-Kovacs, D. and Hauskeller, C. 2012. The Clinician-Scientist: Professional Dynamics in Clinical Stem Cell Research. *Sociology of Health and Illness* 34(4), pp. 497-512.
- Wittgenstein, L. 1953. *Philosophical Investigations*. Sussex: Blackwell Publishing.
- Wolfinger, N. 2002. On Writing Fieldnotes: Collection Strategies and Background Expectancies. *Qualitative Research* 2(1), pp. 85-95.
- Woolgar, S. 1990. Configuring the User: The Case of Usability Trials. *The Sociological Review* 38(S1), pp. 58-99.
- Woolley, C. 2014. *Report to Prevent Future Deaths: Stuart and Hughes 2014-0549*. Ministry of Justice.

## Appendices

### Appendix 1: ONS response to Jim Shannon MP

---



UK Statistics Authority  
1 Drummond Gate  
London  
SW1V 1QQ

Tel: 0207 592 8863  
E-mail: [national.statistician@statistics.gov.uk](mailto:national.statistician@statistics.gov.uk)  
[www.statisticsauthority.gov.uk](http://www.statisticsauthority.gov.uk)

---

John Pullinger CB CStat | National Statistician

Jim Shannon MP  
House of Commons  
London  
SW1A 0AA

9 July 2015

Dear Mr Shannon,

As National Statistician and Chief Executive of the UK Statistics Authority, I am replying to your Parliamentary Question asking how many people have died of sudden arrhythmic cardiac death syndrome in each of the last five years (5932).

The number of deaths registered in England and Wales each year by sex, age and underlying cause are available from the Office for National Statistics (ONS) release, *Mortality Statistics: Deaths Registered in England and Wales (Series DR)*. This is available on the ONS website, at: [www.ons.gov.uk/ons/rel/vsob1/mortality-statistics-deaths-registered-in-england-and-wales-series-dr/index.html](http://www.ons.gov.uk/ons/rel/vsob1/mortality-statistics-deaths-registered-in-england-and-wales-series-dr/index.html).

Table 1 (at Annex A) provides the number of deaths with an underlying cause of sudden cardiac death, cardiac arrhythmias unspecified, and sudden death cause unknown, registered in each year from 2009 to 2013 (the latest year for which data are available). There are two issues to bear in mind when considering this data:

- Figures have been given for each of these underlying causes because ONS does not have a standard definition of sudden arrhythmic death syndrome, and sometimes these deaths are referred to using the broader term sudden adult death syndrome.
- The underlying cause of death provided in ONS's statistics is dependent on the precise wording on the death certificate. Deaths certified as being due to sudden adult death syndrome, or that were stated as sudden with no cause identified, are recorded as sudden death, cause unknown.

Sudden arrhythmic deaths are recorded as deaths from cardiac arrhythmia, and do not state whether they were sudden or not. There are other conditions that can cause sudden cardiac deaths, for example long QT syndrome, and progressive cardiac conduction defect, which are not included in the figures provided in Table 1.

Yours sincerely

A handwritten signature in black ink, appearing to read 'John Pullinger'.

John Pullinger

## Annex A

Table 1: Number of deaths with an underlying cause of sudden cardiac death, cardiac arrhythmias unspecified and sudden death cause unknown, England and Wales, registered in each year between 2010 and 2013.<sup>1,2</sup>

Registration year	Sudden cardiac death	Cardiac arrhythmia, unspecified	Sudden death, cause unknown	Deaths
				Total
2009	73	127	51	251
2010	64	110	94	268
2011	51	132	94	277
2012	67	146	80	293
2013	80	157	85	322

Source: *Mortality Statistics: Deaths Registered in England and Wales (Series DR)*

<sup>1</sup> Cause of death was defined using the International Classification of Diseases, Tenth edition (ICD-10) codes I46.1 for sudden cardiac death, I49.9 for cardiac arrhythmia, unspecified and R96 for sudden death, cause unknown.

<sup>2</sup> Figures include deaths of non-residents.

## Appendix 2: The AICC Pathway for the Management of SADS

Phenotype	GP	Referral Point	Investigations	Phenotype identified in relative?	Genetic testing	Follow-up	Therapy?
<b>SADS:</b> Unexplained SCD  (also consider Sudden Unexplained Death in epilepsy [SUDEP] as SADS until proven otherwise)	Refer first degree blood relatives including children  Unexplained syncope or seizures?  Refer urgently	ICC clinic	Expert pathology  Review coronial reports, PMH, old ECGs	YES  YES Appropriate to phenotype and refer at risk relatives (see recommended pathway)	YES Appropriate to phenotype and refer at risk relatives	YES Appropriate to phenotype and risk	NO
Investigations before referral:  Expert autopsy  Retention of fresh tissue or blood for freezing +/- DNA extraction	More distant blood relative: Seek advice from ICC clinic  Refer key relatives who are likely carriers and/or suffer unexplained syncope or seizures		Molecular autopsy of SADS victim if suitable tissue retained.  Consider de novo disease.	Follow-up children when able to complete testing and then once during, once after puberty and then once in adulthood, investigating as appropriate.  Discharge adults	Re-refer: <ul style="list-style-type: none"> <li>urgently if symptomatic</li> <li>if a phenotype is identified in another blood relative</li> </ul>		





## **Appendix 3: Research Participant Information Sheet**

### **Genetic Testing for Sudden Arrhythmic Death Syndrome and the Coroner's system of England and Wales**

This document will briefly set out what the research project is about, what will be expected of you as a participant, what the potential implications of participating are as well as how the data gathered will be used.

This research will be conducted by Chris Goldsworthy a PhD student at Cardiff University School of School of Social Sciences, located within the ESRC Centre for the Economic and Social Aspects of Genomics (CESAGen).

#### **Background information**

This research is concerned with examining how different professional groups understand and experience post-mortem genetic testing for SADS, with the aim of understanding how this process can work in practice. This is an important question as currently although this type of genetic testing is available it is not undertaken in a large scale. To unpick this issue the research will require the knowledge and experience of experts in SADS conditions, genetic testing for these conditions and experts with a broader interest in public health and the implications of this genetic testing upon public health.

#### **Participation**

Practically this research will be carried out through a series of audio recorded interviews with expert participants. These interviews will be conducted at times and places agreed upon by the participant and the researcher and are estimated to last around 1 hour. Participants will be expected to discuss at length experience they have had with SADS particularly referring to the use of genetic testing as a method of diagnosis or establishing cause of death. Participants will also be asked about their professional relationship with other professional groups that are potentially involved in the process of conducting genetic testing for SADS following the death of an individual. Participants will also be asked about the potential impact of conducting the concerned genetic tests.

By participating in this research the participant is required to present their professional opinion, as such there is potential risk to the professional authority of the participant may occur as a result of participation. However this risk is minimized by the methodical anonymization of all data upon transcription, whereby all identifying information will be removed including names and places.

Effort will also be taken to ensure the presentation of the data is in keeping with the participants' intentions.

### **Confidentiality**

Confidentiality of data will be ensured through anonymization at the earliest possible opportunity ensuring all identifying data are altered or omitted. Following transcription of the data all audio recordings will be deleted. Only the named researcher will have access to the data and it is the responsibility of the single researcher to transcribe and analyse the data, this limits access to one individual. All audio recordings will be taken off site to be transcribed at the Chief Investigators host institution.

### **How the data will be used**

The data will be used primarily to support the construction of the researchers PhD thesis. However it is expected that other documents will result from the research. These include academic articles in the field of Sociology, as well as professional documents aimed at specialist professions concerned with SADS or post-mortem genetic testing. There is also the potential that the research will be used to support guidelines for the practical organisation of conducting post-mortem genetic tests for SADS.

### **Contact details**

For further information contact:

Chris Goldsworthy

PhD Student

Cardiff University School of Social Sciences:

Email: [goldsworthycc@cf.ac.uk](mailto:goldsworthycc@cf.ac.uk)

For concerns about how the research was conducted please contact:

Tom Hall

Chair of the School Research Ethics Committee

Cardiff University School of Social Sciences

Email: [hallta@cardiff.ac.uk](mailto:hallta@cardiff.ac.uk)

### **Acknowledgment**

This research is supported by the ESRC and SADS UK.

The Sponsor of this research is Cardiff University.

## Appendix 4: Consent Form

### Consent form: Genetic Testing for SADS and the Coroner's System of England and Wales

Name of Researcher: Chris Goldsworthy

	<b>Please initial</b>
1. I have read and understood the information sheet for the above study and I understand the implications of participating in the study. I have been given adequate time to consider the information received and I have been given the opportunity to ask questions and have had these questions suitably answered.	
2. I understand that my participation is voluntary and I may withdraw at any time.	
3. I consent to being Audio recorded and understand that direct quotations may be used in publications.	
4. I consent to take part in this study.	

Signature of Participant.....

Date.....

Signature of Researcher.....

Date.....