

**The natural history, non-invasive sampling,
activity patterns and population genetic
structure of the Bornean banteng *Bos javanicus*
lowi in Sabah, Malaysian Borneo.**

Penny C. Gardner



December 2014

Organisms and the Environment Division, School of Biosciences,

Cardiff University

**This thesis is submitted to Cardiff University in candidature for the degree
of Doctor of Philosophy**

Primary supervisor:**Dr. Benoît Goossens**

Danau Girang Field Centre, c/o Sabah Wildlife Department, Wisma Muis, 88100 Kota Kinabalu, Sabah, Malaysia.

Cardiff School of Biosciences, Cardiff University, Sir Martin Evans Building, Museum Avenue, Cardiff CF10 3AX, UK

Secondary supervisor:**Prof. Michael W. Bruford**

Cardiff School of Biosciences, Cardiff University, Sir Martin Evans Building, Museum Avenue, Cardiff CF10 3AX, UK

Advisor:**Dr. Ian P. Vaughan**

Cardiff School of Biosciences, Cardiff University, Sir Martin Evans Building, Museum Avenue, Cardiff CF10 3AX, UK

Internal assessor (years 1 & 2):**Dr. Joanne Lello**

Cardiff School of Biosciences, Cardiff University, Sir Martin Evans Building, Museum Avenue, Cardiff CF10 3AX, UK

This project was funded by a scholarship from Houston Zoo and grants from Yayasan Sime Darby, The Mohamed bin Zayed Species Conservation Fund, the Malaysian Palm Oil Council (MPOC) and Woodland Park Zoo. The local counterpart was Datuk Dr. Laurentius Ambu of the Sabah Wildlife Department (research permit: UPE: 40/200/19/2567) and the project was in collaboration with Datuk Dr. Sam Mannan of the Sabah Wildlife Department, and Malua BioBank.



Declaration

This work has not been submitted in substance for any other degree or award at this or any other university or place of learning, nor is being submitted concurrently in candidature for any degree or other award.

Signed (candidate) Date

STATEMENT 1

This thesis is being submitted in partial fulfillment of the requirements for the degree of(insert MCh, MD, MPhil, PhD etc, as appropriate)

Signed (candidate) Date

STATEMENT 2

This thesis is the result of my own independent work/investigation, except where otherwise stated.

Other sources are acknowledged by explicit references. The views expressed are my own.

Signed (candidate) Date

STATEMENT 3

I hereby give consent for my thesis, if accepted, to be available online in the University's Open Access repository and for inter-library loan, and for the title and summary to be made available to outside organisations.

Signed (candidate) Date

STATEMENT 4: PREVIOUSLY APPROVED BAR ON ACCESS

I hereby give consent for my thesis, if accepted, to be available online in the University's Open Access repository and for inter-library loans **after expiry of a bar on access previously approved by the Academic Standards & Quality Committee.**

Signed (candidate) Date



Dedication

To Ermintrude, my first great bovine love.

To my family and Paul, thank you for your love and support.

In memory of my Nan.

Acknowledgements

It has been a privilege to have been supervised by Benoît Goossens and Mike Bruford whom are truly inspirational; sincere thanks for your patience, guidance and enthusiasm. To Ian Vaughan, my advisor, whose enthusiasm for spatial statistics knows no bounds.

Thank you to Maria Joanna Ferreira da Silva for being the driving-force behind the molecular work, and for your positivity and friendship, and to Pablo, who painstakingly spent hours explaining a variety of molecular-related subjects to me.

I'm enormously thankful to Peter Riger, for financial support and equipment but above all for your faith in me and this project. To my counterpart Datuk Dr. Laurentius Ambu of the Sabah Wildlife Department for his support in this project, the Economic Planning Unit (EPU) and Sabah Biodiversity Centre (SaBC) for permission to conduct this research and export permits, Dr. Sen Nathan, for your veterinary expertise, enthusiasm and friendship, the WRU team for assistance with hunters, and to those that facilitated this project: Rashid Saburi, Sumbin Gadas and Tabin wildlife rangers, Sylvester Saimin, Soffian Abu Bakar, Indra Sunjoto, Rayner Bili and Malua forestry rangers, Jadda Suhaimi and Maliau rangers, Waidi Sinun and the Yayasan Sabah Foundation. To Simon Amos and RopeSkills, one day we will catch a banteng!

Thank you to my collaborators who contributed data on banteng, advice, and even equipment: Merril Halley, Andrew Hearn and Joanna Ross, Andreas Wilting, Jedediah Brodie, Oliver Wearn, Torsten Bohm, Petra Kretschmar, and to Daniel Kohnx for photographs of Burmese banteng in Thailand. To James Robins for enriching my life with jungle tales, social time and for his sense of humour...always remember how lucky you are to actually see your species. To all the research assistants that worked tirelessly cutting trails, checking camera traps, collecting banteng dung, and for tolerating a demanding female orang-putih: Roslee, Rusdi, Kamil, Pearch, Johnika, Raupie and Siti, and to the field leaders Jocelyn Goon and Lim Hong Ye (aka Hugo) for their hard work and patience in everything ranging from dung requests, long-distance off-road driving, budgets and car mechanics. To the volunteers and PTY students who sacrificed their blood to the leeches and their sweat to the forest: Becky Lawrence, Roshan Guharajan, Melynda Cheok, Shu Woan, Elena, Joleen Jolevine, Rob Colgan, Rodi Tenquist-Clarke, Michael Reynolds, Grace Dibden, Helen Cadwallader, Stephanie Ridge and Naomi Prosser who were an absolute pleasure to work with, and the newbies Molly Ellis and Katie Journeaux. It has been a pleasure to have worked in the C.5/15 lab (in both the early and the more recent days) alongside: Mireille Johnson, Samrat Mondol, Tânia Minhós, Zhijie Ma, Mafalda Costa, Vicky, Xiang Zhan, Pierfrancesco Sechi, Azniza Mahyudin, Frauke Kruger, Silke Waap, Isa Rita Russo, Renata Jorge, Jenny Brunke, Niall McCann, Hannah Burton, Josie Jackson, Rose Moorhouse-Gann, Camila Ryan, Jen Stockdale, Mario Barbato. To Eyen Khoo, Nurzhafarina Othman, and my DGFC family for your warmth and friendship. A special thank you to Dave Stanton for assisting with phylogeny construction and housing (!), to Milena Salgado-Lynn for a skype lesson on multiplex design, and to João Torres for taking the time to create haplotype maps for me.

TABLE OF CONTENTS

DECLARATION	II
ACKNOWLEDGEMENTS.....	IV
LIST OF PUBLICATIONS	VII
SUMMARY.....	XVII
CHAPTER 1: GENERAL INTRODUCTION.....	1
1.1 FOREWORD AND JUSTIFICATION.....	1
1.2 BIOGEOGRAPHY OF SABAH (MALAYSIAN BORNEO).....	2
1.3 TAXONOMIC CLASSIFICATION OF THE STUDY SPECIES.....	4
1.4 ECOLOGICAL NON-INVASIVE POPULATION STUDIES	8
1.4.1 <i>Non-invasive sampling methods</i>	8
1.4.2 <i>Sampling efficiency and population parameter estimation</i>	9
1.4.3 <i>Activity budgets</i>	13
1.5 CONSERVATION GENETICS	14
1.5.1 <i>Non-invasive molecular sampling</i>	15
1.5.2 <i>Mitochondrial (mt) DNA</i>	16
1.6 AIMS AND HYPOTHESES	18
1.8 REFERENCES	20
CHAPTER 2: THE NATURAL HISTORY OF BANTENG (<i>BOS JAVANICUS</i>)	28
2.1 ABSTRACT	28
2.2 THE NATURAL HISTORY OF BANTENG (<i>BOS JAVANICUS</i>).....	29
2.3 REFERENCES	43
CHAPTER 3: UNTIL THE COWS COME HOME; EFFECTIVE NON-INVASIVE SAMPLING OF THE RARE BORNEAN BANTENG (<i>BOS JAVANICUS LOWI</i>)	45
3.1 ABSTRACT	45
3.2 INTRODUCTION	45
3.2.1 <i>Non-invasive sampling methods</i>	45
3.2.2 <i>Non-invasive sampling of banteng</i>	49
3.3 METHODS & STUDY SITES	51
3.3.1 <i>Study Areas</i>	51
3.3.2 <i>Non-invasive multi-sampling using camera traps and sign surveys</i>	52
3.3.3 <i>Detection success and effectiveness of sampling</i>	57
3.3.4 <i>Accumulation curves</i>	58
3.4 RESULTS	61
3.4.1 <i>Detection success and sampling efficiency</i>	61
3.4.2 <i>Accumulated and extrapolated population estimates</i>	64
3.4.3 <i>Incremental sampling</i>	67
3.5 DISCUSSION	72
3.5.1 <i>Detection success and effectiveness of sampling</i>	72
3.5.2 <i>Individual recognition and recapture history</i>	73
3.5.3 <i>Population size</i>	74
3.5.4 <i>Conservation and management</i>	75
3.7 REFERENCES	77
CHAPTER 4: ACTIVITY BUDGETS AND THERMAL-REGULATION BEHAVIOUR OF THE BORNEAN BANTENG (<i>BOS JAVANICUS LOWI</i>) IN REGENERATING LOGGED FORESTS	82
4.1 ABSTRACT	82
4.2 INTRODUCTION	83
4.3 MATERIALS AND METHODS	85
4.3.1 <i>Study Areas</i>	85

4.3.2	<i>Field methods</i>	87
4.3.3	<i>Statistical analysis</i>	89
4.3.4	<i>Evidence of illegal activity</i>	92
4.4	RESULTS	92
4.4.1	<i>Activity patterns</i>	92
4.4.2	<i>Ambient forest temperatures</i>	93
4.4.3	<i>Activity budgets of specific behaviours</i>	94
4.4.4	<i>Observations of human-driven disturbances</i>	98
4.5	DISCUSSION	100
4.5.1	<i>Activity patterns</i>	100
4.5.2	<i>Effect of forest regeneration upon ambient temperatures</i>	101
4.5.3	<i>Thermo-regulated activity budgets</i>	102
4.5.4	<i>Hunting of banteng and habitat encroachment</i>	104
4.5.5	<i>Conservation of banteng</i>	105
4.8	APPENDICES	111
	111
CHAPTER 5: POPULATION GENETIC STRUCTURE OF THE BORNEAN BANTENG (<i>BOS JAVANICUS LOWI</i>)		113
5.1	ABSTRACT	113
5.2	INTRODUCTION	114
5.3	MATERIALS AND METHODS	117
5.3.1	<i>Samples</i>	117
5.3.2	<i>Lab methodology</i>	119
5.3.3	<i>Statistical analyses</i>	122
5.4	RESULTS	127
5.4.1	<i>Sampling</i>	127
5.4.2	<i>Amplification success of markers</i>	128
5.4.3	<i>Phylogeny of ancestral maternal lineage</i>	128
5.4.4	<i>Population genetic diversity and structure</i>	129
5.5	DISCUSSION	141
5.5.1	<i>Amplification success</i>	141
5.5.2	<i>Phylogeny</i>	142
5.5.3	<i>Inferring demographic history</i>	144
5.5.4	<i>Genetic diversity</i>	145
5.5.5	<i>Conservation implications</i>	146
5.5.6	<i>Further work</i>	147
5.7	REFERENCES	149
5.8	APPENDICES	156
CHAPTER 6: GENERAL DISCUSSION		165
6.1	OVERVIEW	165
6.2	THE NATURAL HISTORY OF BANTENG	165
6.3	NON-INVASIVE SURVEY METHODS AND PRELIMINARY POPULATION SIZE ESTIMATION	170
6.4	ACTIVITY PATTERNS AND THERMO-REGULATED BEHAVIOUR	170
6.5	POPULATION GENETIC DIVERSITY OF BORNEAN BANTENG	171
6.6	IMPLICATIONS FOR CONSERVATION OF BANTENG	172
6.7	FUTURE WORK	177
6.8	REFERENCES	178

TABLE OF FIGURES

- FIGURE 1.1: EVIDENCE OF PAST HUNTING ACTIVITY OF BANTENG IN SABAH: PHOTOGRAPH OF A TROPHY HEAD OF *B. J. LOWI* LOCATED IN A LONG HOUSE IN LONG PASIA VILLAGE (INTERIOR OF SABAH) WHICH WAS SHOT OVER 40 YEARS AGO BY THE VILLAGE CHIEF IN THE SURROUNDING FOREST. THE TROPHY HEAD WAS RECORDED DURING A STATE-WIDE SURVEY TO CONFIRM THE PRESENCE OF REMNANT POPULATIONS OF BANTENG (© PENNY C. GARDNER)..... 3
- FIGURE 1.2: A NEIGHBOUR-JOINING PHYLOGENETIC TREE OF *BOS* FROM MACEachern et al., 2009 BASED ON MITOCHONDRIAL (MTDNA) LINEAGES FROM 15 GENES TO ILLUSTRATE THE EVOLUTIONARY HISTORY OF THE BOVINI GENERA. BRANCH SUPPORT IS INDICATED AT NOTES IN PERCENTAGE FREQUENCIES (%) USING 5,000 BOOTSTRAPS. THE RECONSTRUCTION SUGGESTS THE BANTENG (*BAN*) ORIGINATES FROM THE SAME CLADE AS THE GAUR (*GAU*) AND YAK (*YAK*) AND THEREFORE ARE MORE CLOSELY RELATED. THE SPECIES OUTGROUP USED TO INITIATE THE MODEL WAS THE AFRICAN ANTELOPE ELAND (*ELA*). OTHER SPECIES INCLUDED WERE: ANC: ANCIENT (AUROCHS OR *BOS PRIMIGENIUS*), BIS: BISON, BUBB & BUBC: ASIAN BUFFALO, MIT: MITHAN, HOL: HOLSTEIN, SYN: AFRICAN BUFFALO, TUL: TULL, HERD: HEREFORD, MUR & IND: INDIAN WATER BUFFALO, NOTE: SCALE BAR IS MILLIONS OF YEARS (MYA). 4
- FIGURE 1.3: PHOTOGRAPHS OF BANTENG BULLS OF THE THREE SUBSPECIES WITH SUBTLE VARIATIONS IN PELAGE COLOUR AND BODY SIZE: TOP LEFT: THE BORNEAN BANTENG (*B. J. LOWI*) WITH VERY DARK PELAGE COLOURATION AND A STOUT COMPACT BODY SIZE, PHOTOGRAPHED IN MALUA FOREST RESERVE IN MALAYSIAN STATE OF SABAH AS PART OF THIS STUDY (© DANAU GIRANG FIELD CENTRE/SABAH WILDLIFE DEPARTMENT: P. GARDNER). TOP RIGHT: A BANTENG BULL IN THAILAND (*B. J. BIRMANICUS*) WITH A BROWN PELAGE AND HEAVY-SET FACIAL FEATURES (© D. KOHN). BOTTOM: A HERD OF JAVAN BANTENG (*B. J. JAVANICUS*) PHOTOGRAPHED ON THE INDONESIAN ISLAND OF JAVA WITH THE BULLS EVIDENT BY THEIR DARK BROWN/BLACK PELAGE COLOUR. THE FACIAL STRUCTURE OF THE JAVAN BANTENG SHOWS SUBTLE DIFFERENCES IN THEIR ELONGATED FACIAL STRUCTURE (© S. PUDYAMTOKO). 5
- FIGURE 1.4: THE WORLD-WIDE DISTRIBUTION OF *BOS JAVANICUS* WITH AREAS OF RECENT EXTINCTIONS ARISING FROM LAND-USE CONVERSION AND ERADICATION BY HUNTING AND ALSO CONFIRMED REMNANT POPULATIONS PREVIOUSLY UNDOCUMENTED. THIS MAP IS AN UPDATED VERSION OF THE IUCN RED LIST OF THREATENED SPECIES ASSESSMENT WHICH IS CURRENTLY UNDER REVIEW, AND THE REVIEW MAY POSSIBLY ENDORSE THE CHANGE OF SUBSPECIES *B. J. BIRMANICUS* IN KALIMANTAN (INDONESIAN, BORNEO) TO *B. J. LOWI* BASED ON A LACK OF EVIDENCE WITHIN THE LITERATURE (GARDNER ET AL., N.D.). DISTRIBUTION OF SUBSPECIES: MAINLAND BANTENG *B. J. BIRMANICUS* (BLUE CIRCLE), BORNEAN BANTENG *B. J. LOWI* (RED CIRCLE), AND JAVAN BANTENG *B. J. JAVANICUS* (GREEN CIRCLE)..... 6
- FIGURE 1.5: PREHISTORIC CAVE ART OF AN ANIMAL WHICH IS THOUGHT TO BE THE BANTENG, FOUND IN A CAVE IN KALIMANTAN (INDONESIAN, BORNEO) DURING A CAVING EXPEDITION BY A FRENCH-INDONESIA TEAM IN 1994. THE PAINTINGS ARE THOUGHT TO DATE >10,000 YEARS AGO WHICH MAY CORROBORATE THE DISPERSAL OF THE BANTENG ACROSS THE SUNDA SHELF DURING THE LAST GLACIAL MAXIMUM BETWEEN 22,000-19,000 YEARS AGO (CHAZINE 2005)..... 7
- FIGURE 1.6: THE MITOCHONDRIAL CIRCULAR GENOME (MTDNA) OF *BOS INDICUS* WHICH ORIGINATES FROM COUNTRIES WITH A WARM CLIMATE (MEIRELLES ET AL., 1999). THE MTDNA IS FOUND WITHIN THE ORGANELLES OF CELLS OF EUKARYOTES, AND IS DIVIDED INTO GENES THAT CODE FOR AMINO ACIDS AND SYNTHESISE PROTEINS (CYTOCHROME-*B*) AND NON-CODING REGION (CONTROL REGION/D-LOOP). THE MTDNA DOES NOT RECOMBINE BUT IS UNDER SELECTION, AND SIGNATURES OF SELECTION ARE IDENTICAL TO MUTATIONS WHICH ARE USED TO DEFINE HAPLOTYPES. NOTE, IN ITALICS ARE SITES FOUND EXCLUSIVELY IN *B. INDICUS* AND (*HINDIII*) IN *B. TAURUS* MTDNA. 17
- FIGURE 3.1: THE LOCATION OF SABAH (INSET) AND A MAP OF SABAH WITH THE LOCATIONS OF THE TWO STUDY SITES IN THE CENTRAL AND EAST REGIONS, WHICH ARE CATEGORISED PRIMARILY BY TROPICAL LOWLAND DIPTEROCARP FOREST AND CONTAIN BANTENG. IN THE CENTRAL REGION OF SABAH IS MALUA FOREST RESERVE, AN FSC (FOREST STEWARDSHIP COUNCIL) CERTIFIED FOREST WITH A RECENT HISTORY OF SUSTAINABLE LOGGING PRACTICES, AND IN THE EAST IS TABIN WILDLIFE RESERVE, A FULLY PROTECTED WILDLIFE SANCTUARY WITH NO LOGGING ACTIVITY SINCE THE LATE 1980S. NOTE, OTHER COLOURS RELATE TO FOREST CLASSIFICATION DESIGNATED BY THE SABAH FORESTRY DEPARTMENT: VIRGIN JUNGLE RESERVE (RED), PROTECTED FOREST RESERVE (DARK GREEN), COMMERCIAL FOREST RESERVE (LIGHT GREEN), SABAH

- PARKS (ORANGE), WILDLIFE RESERVE (LIGHT BLUE), MANGROVE FOREST RESERVE (PINK), AND AMENITY FOREST RESERVE (BROWN). 54
- FIGURE 3.2: MAP OF THE FULLY PROTECTED WILDLIFE SANCTUARY TABIN WILDLIFE RESERVE IN THE EAST OF THE MALAYSIAN STATE OF SABAH WITH SECONDARY FOREST IN HASH AND A CENTRAL CORE CLASSIFIED AS A FORESTRY RESERVE (OUTLINED BY BLACK) AND A PATCH OF VIRGIN FOREST (WHITE PATCH IN CENTRE). THE MAP SHOWS THE POSITIONS OF THE FOUR GRIDS WHERE CAMERA TRAP AND SIGN SURVEYS WERE CONDUCTED (DEFINED BY DIFFERENT SYMBOLS) THAT WERE SEGREGATED BY A MINIMUM OF 10KM TO AVOID AUTOCORRELATION. 55
- FIGURE 3.3: MAP OF MALUA FOREST RESERVE, A COMMERCIAL TIMBER FOREST WITH FSC (FOREST STEWARDSHIP COUNCIL) CERTIFICATION FOR SUSTAINABLE LOGGING PRACTICES. THE FOREST IS PRIMARILY SECONDARY LOWLAND DIPTEROCARP AND CHARACTERISED BY A VAST NETWORK OF ABANDONED LOGGING ROADS. THE MAP SHOWS THE LOCATIONS OF THE THREE GRIDS (DEFINED BY DIFFERENT SYMBOLS) WHERE CAMERA TRAP AND SIGN SURVEYS WERE CONDUCTED, WITH EACH GRID SEGREGATED BY A MINIMUM DISTANCE OF 10KM. 56
- FIGURE 3.4: PHOTOGRAPH OF BANTENG SHOWING SCARS IN THE EAR AND ON THE BODY WHICH WERE USED FOR IDENTIFICATION PURPOSES. AN EXAMPLE IDENTIFICATION OF A MATURE BANTENG BULL IN MALUA FOREST RESERVE IN THE MALAYSIAN STATE OF SABAH (BORNEO) USING SCARS ON THE BODY AND TEARS IN THE EAR CIRCLED IN RED. (© DANAU GIRANG FIELD CENTRE/SABAH WILDLIFE DEPARTMENT: PENNY GARDNER) 58
- FIGURE 3.5: FOUR INCIDENCE-BASED NON-PARAMETRIC ESTIMATORS USED FOR ESTIMATING THE POPULATION SIZE. THE INCIDENCE-BASED DATA COMPRISED OF PHOTOGRAPHIC RECAPTURES OF INDIVIDUALS ACCUMULATED OVER THE SURVEY PERIOD USING CAMERA TRAPS. THE FOUR NON-PARAMETRIC ESTIMATORS WERE TAKEN FROM O'HARA AND OKSANEN (2014). 60
- FIGURE 3.6: ACCUMULATION CURVES OF BANTENG OVER TIME (STANDARDISED 87 DAY SURVEY ACROSS ALL GRIDS) IN MALUA FOREST RESERVE (MFR) USING RANDOM PERMUTATIONS OF INDIVIDUALS WITHOUT REPLACEMENT IDENTIFIED ACCORDING TO A BEST CASE SCENARIO (BEST), A WORST CASE SCENARIO (WORST) AND ACCORDING TO NO IDENTIFICATION OF INDIVIDUALS (NAÏVE) WITH STANDARD ERROR BARS. NOTE, THE SCALE DIFFERENCES IN THE Y-AXIES BETWEEN FORESTS DUE TO A DIFFERENT NUMBER OF INDIVIDUALS IDENTIFIED. 65
- FIGURE 3.7: ACCUMULATION CURVES OF BANTENG OVER TIME (STANDARDISED 87 DAY SURVEY ACROSS ALL GRIDS) IN TABIN WILDLIFE RESERVE (TWR) USING RANDOM PERMUTATIONS OF INDIVIDUALS WITHOUT REPLACEMENT IDENTIFIED ACCORDING TO A BEST CASE SCENARIO (BEST), A WORST CASE SCENARIO (WORST) AND ACCORDING TO NO IDENTIFICATION OF INDIVIDUALS (NAÏVE) WITH STANDARD ERROR BARS. NOTE, THE SCALE DIFFERENCES IN THE Y-AXIES BETWEEN FORESTS DUE TO A DIFFERENT NUMBER OF INDIVIDUALS IDENTIFIED. 65
- FIGURE 3.8: ACCUMULATION CURVES OF BANTENG ACROSS CAMERA TRAP STATIONS IN MALUA FOREST RESERVE (MFR) USING RANDOM PERMUTATIONS OF INDIVIDUALS WITHOUT REPLACEMENT IDENTIFIED ACCORDING TO A BEST CASE SCENARIO (BEST), A WORST CASE SCENARIO (WORST) AND ACCORDING TO NO IDENTIFICATION OF INDIVIDUALS (NAÏVE) WITH STANDARD ERROR BARS. NOTE, THE SCALE DIFFERENCES IN THE AXES BETWEEN FORESTS DUE TO A DIFFERENT NUMBER OF CAMERA TRAP STATIONS USED AND NUMBER OF INDIVIDUALS IDENTIFIED. 66
- FIGURE 3.9: ACCUMULATION CURVES OF BANTENG ACROSS CAMERA TRAP STATIONS IN TABIN WILDLIFE RESERVE (TWR) USING RANDOM PERMUTATIONS OF INDIVIDUALS WITHOUT REPLACEMENT IDENTIFIED ACCORDING TO A BEST CASE SCENARIO (BEST), A WORST CASE SCENARIO (WORST) AND ACCORDING TO NO IDENTIFICATION OF INDIVIDUALS (NAÏVE) WITH STANDARD ERROR BARS. NOTE, THE SCALE DIFFERENCES IN THE AXES BETWEEN FORESTS DUE TO A DIFFERENT NUMBER OF CAMERA TRAP STATIONS USED AND NUMBER OF INDIVIDUALS IDENTIFIED. 66
- FIGURE 4.1: THE LOCATION OF SABAH (INSET) ON THE ISLAND OF BORNEO, AND THE DISTRIBUTION OF THREE FOREST RESERVES WITH DIFFERENT POST-LOGGING REGENERATION AGES IN THE EAST (TABIN WILDLIFE RESERVE (TWR): VERY OLD LOGGED FOREST), CENTRAL (MALUA FOREST RESERVE (MFR): RECENTLY LOGGED FOREST) AND SOUTH-CENTRAL (MALIAU BASIN CONSERVATION AREA (MBCA): OLD LOGGED FOREST) REGIONS OF SABAH, MALAYSIA AND THE DISTRIBUTION OF CAMERA TRAP STATIONS WHERE

- BANTENG DATA WAS OBTAINED. NOTE, OTHER COLOURS RELATE TO FOREST CLASSIFICATION DESIGNATED BY THE SABAH FORESTRY DEPARTMENT: VIRGIN JUNGLE RESERVE (RED), PROTECTED FOREST RESERVE (DARK GREEN), COMMERCIAL FOREST RESERVE (LIGHT GREEN), SABAH PARKS (ORANGE), WILDLIFE RESERVE (LIGHT BLUE), MANGROVE FOREST RESERVE (PINK), AND AMENITY FOREST RESERVE (BROWN)... 86
- FIGURE 4.2: OBSERVED FREQUENCY OF ACTIVITY PATTERNS (I.E. THE NUMBER OF PHOTOGRAPHIC CAPTURES OF BANTENG) FROM CAMERA TRAP EVENT DATA OVER 24 HOURS IN THREE FORESTS WITH DIFFERENT POST-LOGGING REGENERATION TIMES: RECENTLY LOGGED FOREST (MFR: TOP), WITHIN AN OLD LOGGED FOREST (MBCA: MIDDLE), AND WITHIN A VERY OLD LOGGED FOREST (TWR: BOTTOM), WITH NON-PARAMETRIC UPPER AND LOWER 95% CONFIDENCE INTERVALS ESTIMATED FROM 2.5 AND 97.5 PERCENTILES USING 400 BOOTSTRAPS AND A GAMMA ERROR DISTRIBUTION. 95
- FIGURE 4.3: OBSERVED MEAN TEMPERATURE (ALL SITES) AND TEMPERATURE IN OPEN CANOPY STATIONS FROM CAMERA TRAP EVENT DATA OVER 24 HOURS IN THREE FORESTS WITH DIFFERENT POST-LOGGING REGENERATION TIMES: RECENTLY LOGGED FOREST (MFR: TOP), WITHIN AN OLD LOGGED FOREST (MBCA: MIDDLE), AND WITHIN A VERY OLD LOGGED FOREST (TWR: BOTTOM). WITH NON-PARAMETRIC UPPER AND LOWER 95% CONFIDENCE INTERVALS ESTIMATED FROM 2.5 AND 97.5 PERCENTILES USING 400 BOOTSTRAP AND A GAMMA ERROR DISTRIBUTION. 96
- FIGURE 4.4: MEAN DURATION OF THREE ACTIVITY BUDGETS OVER 24 HOURS IN THREE FORESTS WITH DIFFERENT POST-LOGGING REGENERATION TIMES: IN A RECENTLY LOGGED FOREST (MFR: TOP), WITHIN AN OLD LOGGED FOREST (MBCA: MIDDLE), AND WITHIN A VERY OLD LOGGED FOREST (TWR: BOTTOM), WITH BOOTSTRAPPED 95% CONFIDENCE INTERVALS ESTIMATED FROM BOOTSTRAPPING WITH 400 ITERATIONS USING A POISSON ERROR DISTRIBUTION. NOTE: DUE TO VARIATION IN THE NUMBER OF CAPTURES WITHIN EACH FOREST THERE ARE LARGE CHANGES IN THE Y-AXIS SCALE. 97
- FIGURE 4.5: OBSERVED DURATIONS OF ACTIVITY BUDGETS (IN MINUTES) IN THREE DIFFERENT SITE FEATURES (ABANDONED LOGGING ROADS, OPEN CANOPY AND CLOSED CANOPY) IN THREE FORESTS WITH DIFFERENT POST-LOGGING REGENERATION AGES WITH 95% CONFIDENCE INTERVALS EXPRESSED IN THREE SITE FEATURES PREDOMINANT WITHIN RECENTLY LOGGED FOREST (MFR: TOP), OLD LOGGED FOREST (MBCA: MIDDLE) AND A VERY OLD LOGGED FOREST (TWR: BOTTOM). NOTE: DUE TO VARIATION IN THE NUMBER OF CAPTURES WITHIN EACH FOREST THERE ARE LARGE CHANGES IN THE Y-AXIS SCALE. 98
- APPENDIX 4.1: FOUR DIFFERENT METHODS OF LOGGING USED IN SABAH (MALAYSIA BORNEO) WITHIN TROPICAL DIPTEROCARP FORESTS OVER THE PAST SIX DECADES UP UNTIL PRESENT-DAY: CONVENTIONAL, TRADITIONAL AND NEWER REDUCED IMPACT LOGGING (RIL) TECHNIQUES. GENERALLY SPEAKING TRADITIONAL LOGGING METHODS ARE MORE DESTRUCTIVE AND RESULT IN HEAVY IMPACT OF THE SUBSTRATE, WHICH PROVIDES FAVOURABLE CONDITIONS FOR INVASIVE PIONEER SPECIES THAT BANTENG FORAGE UPON. 111
- APPENDIX 4.2: EVIDENCE OF ILLEGAL ACTIVITY COLLECTED SINCE 2011. FROM TOP, LEFT-RIGHT: ARMED HUNTER THAT WAS PART OF A GROUP OF SIX MEN WHICH STOLE CAMERA TRAPS USED FOR BANTENG SURVEYS (MFR), ILLEGAL DEFORESTATION OF TIMBER ADJACENT TO A LARGE RIVER WITHIN A TOTALLY PROTECTED WILDLIFE RESERVE BY A NEARBY VILLAGE, FOR USE FOR BUILDING HOUSES (TWR), HUNTER FROM A NEARBY OIL PALM PLANTATION HUNTING USING A MORE TRADITIONAL METHOD RARELY SEEN: A LONG SPEAR WITH A DOG (MFR), A FOREST BARRICADE IMPLEMENTED BY AN OIL PALM PLANTATION WHICH SHARED THE BORDER WITH A TOTALLY PROTECTED FOREST RESERVE. USUALLY THIS GATE IS USUALLY LOCKED AT NIGHT TO PREVENT VEHICLE ACCESS TO THE FOREST HOWEVER ON THIS OCCASION IT WAS LEFT UNLOCKED FOR ILLEGAL HUNTING ACTIVITY – THE GATE WAS DRIVEN OVER BY HUNTERS IN A 4x4 DURING AN EARLY MORNING CAR CHASE (TWR), A LARGE GROUP OF ARMED HUNTERS WHICH SPOTTED A CAMERA TRAP FOR BANTENG SURVEYS (MBCA), ILLEGAL HARVESTERS WITH FULL BAGS OF SANDAL WOOD TRANSPORTING IT OUT OF THE FOREST AT NIGHT TO AVOID CAPTURE BY RANGERS POSTED AT THE MAIN ACCESS GATE (MBCA). 112
- FIGURE 5.1: THE POSITION OF SABAH, MALAYSIA BORNEO, IN SOUTHEAST ASIA (*INSET*) WITH THE DISTRIBUTION OF THE FOREST RESERVES: ULU-SEGAMA MALUA FOREST RESERVE, MALIAU BASIN CONSERVATION AREA, MALUA FOREST RESERVE AND TABIN WILDLIFE RESERVE. WITHIN EACH FOREST RESERVE ARE THE PRECISE LOCATIONS OF FRESH FAECAL SAMPLES THAT WERE COLLECTED BETWEEN YEARS 2011-2013 AND PRESERVED USING A TWO-STEP (ETHANOL/SILICA GEL) METHOD. NOTE, OTHER COLOURS RELATE TO FOREST

CLASSIFICATION DESIGNATED BY THE SABAH FORESTRY DEPARTMENT: VIRGIN JUNGLE RESERVE (RED), PROTECTED FOREST RESERVE (DARK GREEN), COMMERCIAL FOREST RESERVE (LIGHT GREEN), SABAH PARKS (ORANGE), WILDLIFE RESERVE (LIGHT BLUE), MANGROVE FOREST RESERVE (PINK), AND AMENITY FOREST RESERVE (BROWN)..... 118

FIGURE 5.2: GENOME-WIDE MAP OF THE BOVINE (DOMESTIC CATTLE: *BOS INDICUS*) MITOCHONDRIA SHOWING THE POSITIONS OF THE CYTOCHROME-*B* GENE, tRNA T AND P, AND CONTROL REGION/D-LOOP THAT WERE AMPLIFIED IN BORNEAN BANTENG IN SABAH USING FOUR SMALLER OVERLAPPING FRAGMENTS, WHICH WERE USED FOR ANALYSES OF THE GENETIC STRUCTURE AND PHYLOGENY (MEIRELLES ET AL., 1999). NOTE, IN ITALICS ARE SITES FOUND EXCLUSIVELY IN *B. INDICUS* AND (*HINDIII*) IN *B. TAURUS* MTDNA. 121

FIGURE 5.3: THE EVOLUTIONARY HISTORY OF *BOS* USING THE NEIGHBOUR-JOINING METHOD CONSTRUCTED IN MEGA 6.0 BASED ON 1,000 BOOTSTRAPS TO ESTIMATE PERCENTAGE CONFIDENCE OF CLADES (IN BRACKETS), WHICH WERE HIGH FOR BANTENG (>67%) AND SUPPORTED THE CLADE POSITION AND BRANCH LENGTH. DIVERGENCE TIMES FOR ALL BRANCHING POINTS IN THE TOPOLOGY (LOCATED NEXT TO THE CONFIDENCE OF CLADES BUT NOT IN BRACKETS) WERE CALCULATED WITH THE RELTIME METHOD USING THE BRANCH LENGTHS CONTAINED IN THE INFERRED TREE AND ONE CALIBRATION POINT RANGING BETWEEN MINIMUM 3.89 MYA AND MAXIMUM DIVERGENCE TIME 5.53 MYA BETWEEN BISON (*B. B. BISON*) AND YAK (*B. GRUNNIENS*) (HASSANIN & ROPIQUET 2007; HASSANIN & ROPIQUET 2004). THE ANALYSIS INVOLVED 20 NUCLEOTIDE SEQUENCES, WITH NINE SPECIES OF *BOS* AND ALL THREE SUBSPECIES OF BANTENG, INCLUDING THE SIX HAPLOTYPES IDENTIFIED BY THIS STUDY AND AN OUTGROUP OF GOAT (*CAPRA HIRCUS*). ALL POSITIONS CONTAINING GAPS AND MISSING DATA WERE ELIMINATED. THERE WERE A TOTAL OF 938 POSITIONS IN THE FINAL DATASET. *BOS GAURUS* (A): THAILAND, (B): CAMBODIA, *BOS JAVANICUS JAVANICUS* (A & B):TWO HAPLOTYPES FROM CAMBODIA. 131

FIGURE 5.4: THE EVOLUTIONARY HISTORY OF *BOS* USING THE BAYESIAN METHOD BASED ON 1,000,000 GENERATIONS OF MARKOV MONTE CARLO CHAINS (MCMC) CONSTRUCTED IN MRBAYES. MOLECULAR DATING OF THE TREE WAS CONDUCTED USING A RELAXED CLOCK ASSUMPTION WITH TREE CLOCK PRIORS ($0.001 \pm 95\%$ CI 0.005) AND A DIVERGENCE DATE OF 3.89-5.53 MYA BETWEEN BISON (*B. BISON BISON*) AND YAK (*B. GRUNNIENS*) (HASSANIN & ROPIQUET 2007; HASSANIN & ROPIQUET 2004) WITH A SCALE OF DIVERGENCE OF ONE MILLION YEARS (MYA). CONFIDENCE OF THE CLUSTERS IS ILLUSTRATED AS PERCENTAGE PROBABILITIES IN BRACKETS NEXT TO DIVERGENCE TIMES. THE BAYESIAN POSTERIOR PROBABILITY VALUES FOR EACH OF THE BRANCHES WAS STRONG (72-100%) FOR ALL SPECIES, INCLUDING BANTENG (99-100% FOR *B. J. LOWI* NODES) AND SLIGHTLY LOWER (52%) FOR THE OUTGROUP WATER BUFFALO (*BUBALUS BUBALIS*) AND SAOLA (*PSEUDORYX NGHETINHENSIS*). THE ANALYSIS INVOLVED 20 NUCLEOTIDE SEQUENCES, WITH NINE SPECIES OF *BOS* AND ALL THREE SUBSPECIES OF BANTENG, INCLUDING THE SIX HAPLOTYPES IDENTIFIED BY THIS STUDY AND THE OUTGROUP DOMESTIC GOAT (*CAPRA HIRCUS*). ALL POSITIONS CONTAINING GAPS AND MISSING DATA WERE ELIMINATED, AND A TOTAL OF 938 POSITIONS WERE INCLUDED IN THE FINAL DATASET. PHYLOGENY BY DAVID STANTON. 132

FIGURE 5.5: A MEDIAN-JOINING NETWORK IDENTIFIED SIX DISTINCT HAPLOGROUPS (H_1 TO H_6) IN BORNEAN BANTENG IN SABAH, WITH A PROMINENT STAR-SHAPED PHYLOGENY INDICATIVE OF POPULATION EXPANSION. THE NETWORK WAS CREATED USING n=49 SEQUENCES AND A FRAGMENT LENGTH OF 1,368BP, COVERING MTDNA PARTIAL CYTOCHROME-*B* GENE, tRNA AND PARTIAL D-LOOP. SEQUENCES WERE FROM FOUR FORESTS IN SABAH: TABIN WILDLIFE RESERVE (TWR), ULU-SEGAMA MALUA FOREST RESERVE (USMFR), MALUA FOREST RESERVE (MFR) AND MALIAU BASIN CONSERVATION AREA (MBCA) AND THE SIZE OF THE HAPLOGROUP IS DIRECTLY PROPORTIONAL TO THE NUMBER OF SEQUENCES. 133

FIGURE 5.6: MAP OF THE ISLAND OF BORNEO ILLUSTRATING THE STUDY AREA (LEFT). AN ENLARGED MAP OF THE STUDY AREA WITH HAPLOTYPES MAPPED ACCORDING TO THEIR LOCATION AND THE PROPORTION WITHIN WHICH THEY OCCURRED IN THE HERD. EIGHT HERDS WERE IDENTIFIED ACROSS THE STUDY AREA, WITH ONE IN MBCA (FAR LEFT), TWO IN MFR (CENTRAL LEFT AND CENTRAL TOP), ONE IN USMFR (CENTRAL RIGHT) AND FOUR IN TWR (FAR RIGHT). MAP BY JOÃO TORRES. 134

FIGURE 5.7: THE UNIMODAL OBSERVED MISMATCH DISTRIBUTIONS OF THE FREQUENCY OF PAIRWISE DIFFERENCES FOR TWO SCENARIOS (SCENARIO 1 AND SCENARIO 3) OF THE BORNEAN BANTENG: POPULATION (OBS) COMPARED TO A SIMULATED POPULATION THAT HAD EXPERIENCED EXPANSION (EXP) USING A) A SIGNIFICANT DEVIATION FROM AN EXPANSION MODEL USING ALL SAMPLES FROM ALL FORESTS ($p < 0.05$),

AND B) CONFORMITY TO AN EXPANSION MODEL USING SAMPLES SORTED TO HERD AND FOREST WITH REPLICATES OF EACH SEX REMOVED (SSD: 0.02, HRI: 0.147 NON-SIGNIFICANT). NOTE: THERE IS VARIATION IN THE Y-AXIS SCALE BETWEEN GRAPHS.	140
APPENDIX 5.1: MODIFIED QIAGEN QIAAMP® DNA EXTRACTION PROTOCOL USED FOR OPTIMUM DNA YIELD FROM BANTENG FAECES, COLLECTED AND STORED USING THE TWO-STEP (ETHANOL/SILICA GEL) METHOD. THE FINAL STAGES (20-21) WERE REPEATED FOR DOUBLE DNA YIELD AS PCR AND AMPLIFICATION SUCCESS OF MITOCHONDRIA CYTOCHROME- <i>B</i> GENE, tRNA AND CONTROL REGION/D-LOOP REQUIRED HIGHER QUANTITIES OF DNA.	156
FIGURE 6.2: (<i>LEFT</i>) PHOTOGRAPH OF THE SECURE NORTHWEST GATE INTO TABIN THAT IS UNMANNED BUT MAINTAINED AND TIGHTLY REGULATED BY A PALM OIL PLANTATION AND IS A GOOD EXAMPLE OF COOPERATION BETWEEN STAKEHOLDERS. (<i>RIGHT</i>) PHOTOGRAPH OF THE MAIN GATE LEADING TO THE SOUTHWEST BORDER OF TABIN THAT IS LEFT UNLOCKED AND THEREFORE FACILITATES ACCESS TO ARMED HUNTERS USING VEHICLES AND MOTORBIKES.	175
FIGURE 6.1: MAP OF BORNEO (INSET) AND THE DISTRIBUTION OF TWO BANTENG MOLECULAR MANAGEMENT UNITS (RIGHT), THE CENTRAL FOREST RESERVE SOUTH OF THE KINABATANGAN RIVER, AND TABIN WILDLIFE RESERVE, BASED ON THE OCCURRENCE AND LOCATIONS OF FOUR LOW-FREQUENCY HAPLOTYPES WHICH ARE VULNERABLE TO ERADICATION FROM HUNTING.	175

TABLE OF TABLES

TABLE 3.1: DIFFERENT COMBINATIONS OF STUDY SITES (FOREST), SCENARIO (BEST OR WORST CASE SCENARIO) AND SAMPLING UNIT USED TO TEST ASSUMPTIONS OF ACCUMULATION CURVES. SCENARIOS WERE NAMED FROM THE PERSPECTIVE OF IDENTIFICATION SUCCESS. SCENARIOS: BEST: ALL INDIVIDUALS WERE IDENTIFIED AND THOSE CLASSED AS UNIDENTIFIED IN WORST CASE SCENARIO WERE ASSUMED TO BE A RECAPTURE OF THE MOST CLOSELY-RESEMBLING INDIVIDUAL AND ADDED TO THEIR CAPTURE FREQUENCY. WORST: INDIVIDUALS CONFIDENTLY IDENTIFIED AND ALSO INDIVIDUALS THAT WERE NOT CONFIDENTLY IDENTIFIED, WHICH WERE ASSIGNED A CAPTURE FREQUENCY OF ONE. NAÏVE: EVERY OBSERVATION WAS ASSUMED TO BE A UNIQUE INDIVIDUAL.....	59
TABLE 3.2: ANALYSIS OF VARIANCE (ANOVA) OF THE MEANS FOR EACH OF THE FOUR GEEGLM MODEL TERMS AND INTERACTIONS, WITH THE CHI-SQUARED TEST STATISTIC (X^2), DEGREES OF FREEDOM (DF), SIGNIFICANCE VALUE (ANOVA P VALUE) AND SIGNIFICANCE OF THE RELATIONSHIP: * <0.05, ** <0.01, *** <0.001= HIGHLY SIGNIFICANT, N/A = NO SIGNIFICANCE, ^R = RANDOM TERM.....	62
TABLE 3.3: DESCRIPTION OF GEEGLM MODELS TRANSFORMED TO THE PROBABILITY OF ODDS OF RATIO (OR) ESTIMATES USED TO DETERMINE THE DETECTION EFFICIENCY OF SIGN SURVEYS AND CAMERA TRAP STATIONS AND THE EFFECT OF ENVIRONMENTAL FACTORS. THE PRESENCE/ABSENCE OF THE TARGET SPECIES (BANTENG) EXPLAINED BY (~) THE TWO SURVEY METHODS (METHOD): SIGN SURVEYS (SIGN) AND CAMERA TRAP STATIONS (CAMERA: USED AS INTERCEPT). INTERACTIONS (*) BETWEEN COVARIATES: SURVEY DURATION (SURVEY), PERCENTAGE LEAF COVER (CANOPY), ELEVATION IN METERS ABOVE SEA LEVEL (ELEVATION), ^R = RANDOM TERM. GEEGLM OR MODEL ESTIMATES, WITH LOWER STANDARD ERRORS (OR LOW STD. ERR.) AND UPPER STANDARD ERRORS (OR UPP. STD. ERR.). WITHIN CLUSTER CORRELATION WAS EXPLAINED BY THE MODEL (CORRELATION) AND STANDARD ERRORS (\pm STD ERR.) AND THE SIGNIFICANCE OF THE RELATIONSHIP (P VALUE) DENOTED BY: N/A = NO SIGNIFICANCE, ' = <0.1 MARGINALLY NON-SIGNIFICANT, * = <0.05, ** = <0.01, *** = <0.001 HIGH SIGNIFICANCE.	63
TABLE 3.4: THE ESTIMATED POPULATION SIZE USING INCIDENCE-BASED DATA OF BANTENG AND FOUR DIFFERENT ESTIMATORS WITH ASSOCIATED STANDARD ERRORS (S.E): CHAO1, JACKKNIFE1 (JACK1), JACKKNIFE2 (JACK2), BOOTSTRAPPING (BOOT) AND THE OBSERVED POPULATION SIZE (N_{obs}) FOR EACH FOREST/SCENARIO COMBINATION. THE NUMBER OF INCIDENCES (I.E. BANTENG CAPTURES) (T), THE NUMBER OF SAMPLING UNITS (I.E. THE NUMBER OF CAMERA TRAPS) (T).	69
TABLE 3.5: THE OBSERVED POPULATION SIZE (N_{obs}) AND THE ESTIMATED CHAO1 POPULATION SIZE (N_{est}) INTERPOLATED TP 10-DAY INTERVALS OVER THE SURVEY PERIOD (T) FOR THREE IDENTIFICATION SCENARIOS: BEST (BCS), WORST (WCS) AND NAÏVE (NCS), AND FOR BOTH STUDY SITES: MALUA FOREST RESERVE (TOP) AND TABIN WILDLIFE RESERVE (BOTTOM).....	69
TABLE 3.6: THE OBSERVED POPULATION SIZE (N_{obs}) AND THE ESTIMATED CHAO1 POPULATION SIZE (N_{est}) INTERPOLATED TO 10-STATION INTERVALS OVER THE SURVEY PERIOD (T) FOR THREE IDENTIFICATION SCENARIOS: BEST (BCS), WORST (WCS) AND NAÏVE (NCS), AND FOR BOTH STUDY SITES: MALUA FOREST RESERVE (TOP) AND TABIN WILDLIFE RESERVE (BOTTOM).	70
TABLE 3.7: CHAO2 ESTIMATION OF POPULATION SIZE (N_{est}) OF BANTENG IN MALUA AND TABIN USING INCIDENCE-BASED DATA FROM BOTH SAMPLING UNITS: CAMERA TRAP STATIONS AND SURVEY DAYS, AND THREE IDENTIFICATION SCENARIOS: BEST (BCS), WORST (WCS) AND NAÏVE (NCS). THE NUMBER OF ADDITIONAL SAMPLING UNITS REQUIRED TO OBSERVE A TARGET 95% (⁹⁵ G) AND 99% (⁹⁹ G) OF N_{est} WERE ALSO CALCULATED FOR BOTH SAMPLING UNITS. T = NUMBER OF OBSERVATIONS OF BANTENG, T = NUMBER OF SAMPLING UNITS (CAMERA TRAP STATIONS OR SURVEY DAYS), A1 = NUMBER OF INDIVIDUALS OBSERVED ONCE, A2 = NUMBER OF INDIVIDUALS OBSERVED TWICE OR MORE, N_{obs} = OBSERVED POPULATION SIZE. $Q0$ = THE PROBABILITY THAT THE NEXT INCIDENCE REPRESENTS A PREVIOUSLY UNDETECTED INDIVIDUAL, F0 = THE NUMBER OF UNDETECTED INDIVIDUALS, ϕ = G MUST EXCEED 0.95 AND λ = G MUST EXCEED 0.99 DUE TO THE RESTRICTION $GN_{est} > S_{obs}$: SEE CHAO ET AL (2009) FOR AN EXTENSIVE EXPLANATION ON EQUATIONS. 71	71
TABLE 3.8: THE OBSERVED AND ESTIMATED MINIMUM AND MAXIMUM POPULATION SIZE ESTIMATES USING THE BCS (MIN. POP. SIZES ^B) AND WCS (MAX. POP. SIZE ^W) WITHIN THE SURVEY AREAS OF MALUA FOREST RESERVE AND TABIN WILDLIFE RESERVE. THE OBSERVED POPULATION SIZE IS REPORTED BEFORE EXTRAPOLATION (*) AND THE ESTIMATED POPULATION SIZE AFTER EXTRAPOLATION AND INCLUDING UNDETECTED INDIVIDUALS ([†]).	71

TABLE 4.1: CAMERA TRAP SURVEY INFORMATION AND THE NUMBER OF BANTENG CAPTURES OBTAINED FROM CAMERAS SET BY THE AUTHOR DURING THIS STUDY (¤) AND FROM STUDIES CONDUCTED BY A. HEARN AND J. ROSS ON WILD FELIDS (¥), J. BRODIE ON WILD FELIDS (‡), R. BILI ON SUMATRAN RHINO (Ł), AND T. BOHM ON SUMATRAN RHINO (*) IN THREE FORESTS IN SABAH.....	88
TABLE 5.1: FOUR SETS OF MITOCHONDRIAL (MTDNA) PRIMERS DESIGNED TO AMPLIFY HIGHLY DEGRADED FAECAL DNA OF THE BORNEAN BANTENG. THE PRIMERS AMPLIFY FOUR SHORTER FRAGMENTS IN PARTIAL CYTOCHROME- <i>B</i> GENE, tRNA, AND PARTIAL HYPERVARIABLE CONTROL REGION/D-LOOP. TWO PAIRS INTERNAL PRIMERS WERE ALSO DESIGNED FOR SEQUENCING OF PCR PRODUCTS AS ORIGINAL PRIMERS RESULTED IN POOR QUALITY SEQUENCES OF FRAGMENTS 2 AND 4. THE FOUR FRAGMENTS WERE CONCATENATED USING A CONTIG IN THE SOFTWARE SEQUENCHER 5.2.4.	120
TABLE 5.2: SEQUENCES EXTRACTED FROM THE DATABASE GENBANK USED TO CONSTRUCT A PHYLOGENY OF THE BORNEAN BANTENG. A TOTAL OF NINE SPECIES OF <i>Bos</i> WERE INCLUDED ALONG WITH THE JAVAN AND BURMA BANTENG. THE FRAGMENT SIZE AMPLIFIED IN THE BORNEAN BANTENG WAS TRIMMED TO INCLUDE AS MANY DIFFERENT SPECIES AS POSSIBLE. THE OUTGROUP DOMESTIC GOAT <i>CAPRA HIRCUS</i> IS INDICATED BY *.....	124
TABLE 5.3: PARAMETERS OF GENE FLOW AND GENETIC DIFFERENTIATION BETWEEN SAMPLING LOCATIONS IN TABIN WILDLIFE RESERVE (TWR), ULU-SEGAMA MALUA FOREST RESERVE (USMFR), MALUA FOREST RESERVE (MFR) AND MALIAU BASIN CONSERVATION AREA (MBCA) ACCORDING TO THREE DIFFERENT SCENARIOS: 1) SEQUENCES SORTED ACCORDING TO FOREST OF ORIGIN, 2) SEQUENCES SORTED TO HERD AND FOREST OF ORIGIN, AND 3) SEQUENCES SORTED TO HERD AND FOREST OF ORIGIN WITH DUPLICATE SEXES REMOVED TO REDUCE ERROR ASSOCIATED WITH SAMPLING BIAS. GENETIC DIVERSITY REPORTED AS HAPLOTYPE DIVERSITY (H_b) AND NUCLEOTIDE DIVERSITY (Π). DEMOGRAPHIC HISTORY OF BANTENG WAS TESTED USING THREE STATISTICS TO INVESTIGATE POPULATION EXPANSION AGAINST HYPOTHESES OF NEUTRAL/STABLE POPULATION, SUDDEN POPULATION EXPANSION AND THE MISMATCH DISTRIBUTION.	136
TABLE 5.4: ANALYSIS OF MOLECULAR VARIANCE (AMOVA) OF BANTENG IN SABAH, USING TWO SCENARIOS TO ACCOUNT FOR BIAS WHEN INCLUDING REPEATED SAMPLING OF INDIVIDUALS. DEGREES OF FREEDOM (D.F.), SIGNIFICANCE OF RELATIONSHIP (P-VALUE). GREATER GENETIC VARIATION (82%, $p < 0.05$) WAS EXPLAINED WITHIN HERDS WHEN INCLUDING ALL SEQUENCES FROM ALL FORESTS ($n=49$). FOREST ONLY EXPLAINED A SMALL AMOUNT OF GENETIC VARIATION IN SCENARIO 2 & 3 (5.3% AND 2.2%, RESPECTIVELY).	137
TABLE 5.5: PAIRWISE GENETIC DIFFERENCES (F_{ST}) OF BANTENG IN SABAH BETWEEN HAPLOTYPES CALCULATED ACCORDING TO EACH FOREST (SCENARIO 1: TOP), ACCORDING TO HERDS WITHIN EACH FOREST (SCENARIO 2: MIDDLE) AND ACCORDING TO FOREST AND HERD WITH DUPLICATES REMOVED (SCENARIO 3: BOTTOM). SIGNIFICANCE OF THE PAIRWISE RELATIONSHIPS WAS TESTED USING 1,000 PERMUTATIONS.	139
APPENDIX 5.2: GENBANK ACCESSION NUMBERS AND COMPLETE (ϕ) AND PARTIAL (‡) SEQUENCES OF OTHER <i>Bos</i> SPECIES USED IN THE ALIGNMENT TO DESIGN MTDNA PRIMERS. SEQUENCES WERE USED TO IDENTIFY REGIONS WITH HIGH POLYMORPHISM AND MORE CONSERVED REGIONS WHERE PRIMERS WERE DESIGNED. FOUR OVERLAPPING FRAGMENTS SPANNING CYTOCHROME- <i>B</i> GENE, tRNA AND CONTROL REGION/D-LOOP WERE AMPLIFIED TO CREATE A LONG SEQUENCE FROM EACH <i>B. J. LOWI</i> FAECAL SAMPLE.....	157
APPENDIX 5.3: TWENTY-THREE MICROSATELLITE MARKERS DESIGNED AND ENDORSED BY THE FOOD AND AGRICULTURE ORGANIZATIONS (FAO) COMMISSION ON GENETIC RESOURCES FOR FOOD AND AGRICULTURE (2011) THAT ARE SUITABLE FOR ESTIMATING GENETIC DIVERSITY OF WILD BANTENG. THESE MARKERS WERE PRELIMINARILY TESTED ON BORNEAN BANTENG FAECAL DNA FOR THE FIRST TIME TO MY KNOWLEDGE. THE AIM WAS TO DEVELOP THREE MULTIPLEXES FOR ALLELES SCORING TO ESTIMATE GENETIC DIVERSITY USING THE NUCLEAR GENOME TO CORROBORATE GENETIC DIVERSITY ESTIMATED FROM THE MITOCHONDRIAL (MTDNA) GENOME. THIS INFORMATION IS PRESENTED TO SHOW THE POTENTIAL FOR CONDUCTING FURTHER MOLECULAR INVESTIGATIONS ON GENETIC DIVERSITY, SEX-BIASED DISPERSAL AND MALE POPULATION STRUCTURE USING NUCLEAR DNA, AND ALSO TO CONTRAST OR CORROBORATE GENETIC DIVERSITY AND STRUCTURE ESTIMATED USING MTDNA.	158
APPENDIX 5.4: MICROSATELLITE MARKERS TAKEN FROM THE FOOD AND AGRICULTURE ORGANIZATION OF THE UNITED NATIONS (FAO) GUIDELINES (2011) WITH THE RECOMMENDED ANNEALING TEMPERATURE (T_m) AND THE TEMPERATURES TESTED FOR THIS STUDY. NON-SPECIFIC BANDS WERE EVIDENT FOR SOME MARKER	

PCR PRODUCTS, WHICH INADVERTENTLY LEAD TO LARGE INCREASES IN TM FOR SOME MARKERS (I.E. CSSM66).	161
APPENDIX 5.5: SELECTED MICROSATELLITE MARKERS TAKEN FROM THE FOOD AND AGRICULTURE ORGANIZATION OF THE UNITED NATIONS (FAO) GUIDELINES (2011). PCR ANNEALING TEMPERATURE, MICROSATELLITE MARKER DYES AND MULTIPLEXES WERE DEVELOPED FOR FAECAL DNA OF BORNEAN BANTENG. PRELIMINARY ALLELE SIZES WERE ESTIMATES FROM DILUTION SERIES OF MARKERS.	162
APPENDIX 5.6: MTDNA SEQUENCES OF BANTENG IN SABAH SORTED ACCORDING TO A COMBINATION OF FOUR FORESTS: TWR (TABIN WILDLIFE RESERVE), USMFR (ULU-SEGAMA MALUA FOREST RESERVE), MFR (MALUA FOREST RESERVE) AND MBCA (MALIAU BASIN CONSERVATION AREA), EIGHT HERDS AND SIX HAPLOTYPES FOR EACH SEX. DUPLICATE SEQUENCES OF BOTH SEXES FOR ALL FOREST/HERD/HAPLOTYPE COMBINATIONS WERE REMOVED AND/OR WERE NOT AVAILABLE (*) WHICH RESULTED IN A RESTRICTED DATA SET OF 21 SEQUENCES (√) WHICH WERE USED TO COMPUTE DIVERSITY PARAMETERS FOR SCENARIO 3.	162
APPENDIX 5.7: RESULTS OF AMPLIFICATION SUCCESS OF MOLECULAR SEX MARKERS ON THE Y CHROMOSOME AND PERCENTAGE SUCCESS OF SIX REPEATS CONDUCTED FOR EACH SAMPLE, AND ACQUISITION OF THE FULL CONCATENATED MTDNA SEQUENCE/GENOTYPE. A MALE WAS IDENTIFIED BY AMPLIFICATION OF TWO FRAGMENTS AND A FEMALE BY ONE FRAGMENT. SOME SAMPLES OF OLD FAECES WERE COLLECTED BUT NOT TESTED DUE TO OLD AGE AND PROLONGED UV EXPOSURE (DENOTED BY: X). ONE SAMPLE WAS STORED IN RNALATER (*) WHEREAS ALL OTHERS WERE STORED IN THE TWO-STEP ETHANOL/SILICA GEL METHOD. NON-AMPLIFICATION OF ANY FRAGMENT INDICATED PCR FAILURE AND POSSIBLY INDICATIVE OF POOR QUALITY DNA OR INSUFFICIENT YIELD. THE MALE FRAGMENT WAS MORE DIFFICULT TO AMPLIFY DUE TO THE LARGER FRAGMENT SIZE; AMPLIFICATION FAILURE OFTEN RESULTED IN A VISIBLE SINGLE BAND, POTENTIALLY MISINTERPRETED AS A FEMALE BUT ONLY IF AN INSUFFICIENT NUMBER OF REPEATS WERE CONDUCTED. FOR THIS REASON SIX REPEATS WERE USED.	163
TABLE 6.1: A SUMMARY OF THE AIMS AND HYPOTHESES AND THE RESULTS AND IMPLICATIONS FOR THE CONSERVATION OF BANTENG, THEIR HABITAT AND THE ECOSYSTEM WHICH ARE DETAILED ACCORDING TO EACH CHAPTER IN THIS THESIS.	167

List of publications

Publications associated with this thesis

Gardner, P. C., Pudyatmoko, S., Bhumpakphan, N., Yindee, M., Ambu, L. N., & Goossens, B. (2014). Banteng. In M. Melletti & J. Burton (Eds.), *Ecology, Evolution and Behaviour of Wild Cattle: Implications for Conservation*. Cambridge University Press.

Gardner, P. C., Hedges, S., Pudyatmoko, S., Gray, T. & Timmins, (In review). *Bos javanicus*. IUCN Red List of threatened species.

Wiwit Juwita Sastramidjaja, **Penny C. Gardner**, Benoit Goossens, Laurentius N. Ambu, Erik Meijaard, Yaya Rayadin, Iman Sapari, David W. Macdonald and Susan M. Cheyne. (In prep). The Bornean banteng (tembadau) (*Bos javanicus lowi*): new sightings and distribution update. Target journal: Asian Wild Cattle Specialist Group newsletter.

Prosser, N., **Gardner, P.**, Goossens, B. In review. A Body Condition Scoring System for the Bornean Banteng *Bos javanicus lowi* and the Effect of Forest Management on these Scores in Sabah, Malaysia. Target journal: Biotropica.

Ridge, S., **Gardner, P.**, Goossens, B. In prep. Foraging behaviour and forage choices of the Bornean banteng (*Bos javanicus lowi*) in Sabah, Malaysia. Target journal: Biotropica.

List of publications not directly associated with this thesis

Ancrenaz, M., Sollmann, R., Meijaard, E., Hearn, A.J., Ross, J., Samejima, H., Loken, B., Cheyne, S.M., Stark, D.J., **Gardner, P.C.**, Goossens, B., Mohamed, A., Bohm, T., Matsuda, I., Nakabayasi, M., Lee, S.K., Bernard, H., Brodie., Wich, S., Fredriksson, G., Hanya, G., Harrison, M.E., Kanamori, T., Kretzschmar, P., Macdonald, D.W., Riger, P., Spehar, S., Ambu, L.N., Wilting, A. 2014. Coming down from the trees: Is terrestrial activity in Bornean orang-utans natural or disturbance driven? *Scientific Reports*. 4, e4024.

Nicola K. Abram; Kelly L. Abram; Marc Ancrenaz; Andrew Knight; Joseph Tzanopolis; Douglas MacMillan; Isabelle Lackman; Laurentius Ambu; Andrew Hearne; Jo Ross; Siew Te Wong; Benoit Goossens; Lucy Peter; Milena; Danica Stark; **Penny Gardner**; Robert Ong; Lian Pin Koh; Felicity Oram. In prep. The price of saving threatened biodiversity in an oil palm dominated floodplain system in Malaysian Borneo. Target journal: Conservation Biology.

Gardner, P.C., Ambu, L., Bernard, H., Goossens, B. 2014. New evidence of the rare flat-headed cat and other wild felids in Tabin Wildlife Reserve, Sabah, Malaysia. *CATnews*. 61.

Additional responsibilities arising from this thesis

Research Co-leader: The Bornean Banteng Programme (Danau Girang Field Centre): Conservation and management of the endangered wild cattle *Bos javanicus lowi* in Sabah, funded by Yayasan Sime Darby.

Professional membership: International Union for Conservation of Nature (IUCN) Species Survival Commission (SSC) Asian Wild Cattle Specialist Group (AWCSG): Species coordinator.

Co-supervisor for Cardiff University undergraduate Professional Training Year (PTY) students: Naomi Prosser, Stephanie Ridge, Katie Journeaux, Molly Ellis.

Co-supervisor for Masters student: Hong Ye Lim. Registered at Universiti Malaysia Sabah. Project title: Predictive spatial distribution and mapping of Bornean banteng (*Bos javanicus lowi*) in Sabah, Malaysia

Summary

The banteng (*Bos javanicus lowi*) is an endangered wild bovid that is endemic to the island of Borneo. Within their last stronghold, the Malaysian state of Sabah, their population is believed to be less than 500 individuals, which are threatened with extinction by habitat loss and hunting. The banteng is highly elusive and rarely seen, and their preference for dense and remote tropical forest habitat makes them a highly challenging species to study. No extensive quantitative surveys have been undertaken in Sabah, and there is little information available to underpin their conservation and management. This thesis provides the first baseline data on the Bornean banteng in Sabah using ecological and molecular techniques. In Chapter 2, I created the first extensive natural history account of the banteng, which will help further the knowledge of this species. This compilation helped identify gaps in the knowledge, which were then addressed by this thesis. In Chapter 3, I test non-invasive survey techniques and individual identification, and estimate the population size in two forest reserves. In Chapter 4, I demonstrate that logged forests undergo dramatic changes in structure and ambient temperature, and that banteng mitigate these changes by altering their behaviour to avoid thermal-stress. Chapter 5 presents new information of the population genetic structure of banteng in four forest reserves in Sabah. Using mitochondrial markers I show that the ancestral lineage of the Bornean banteng reinforces the suggestion that they should be recognised as a separate subspecies to the Burmese and Javan banteng. I also show that the banteng experienced a population expansion following their colonisation of Borneo, and that the present genetic diversity indicates the population may be managed as two geographically-distinct units. Chapter 6 summarises the main findings of this thesis and the implications for the conservation of the Bornean banteng in Sabah.

Chapter 1: General introduction

1.1 Foreword and justification

This study was initiated on the grounds that extensive habitat loss, large-scale conversion to mono-crop plantations and widespread hunting pressure threaten the Bornean banteng (*Bos javanicus lowi*) with extinction. In the 1980s the adverse effects of these issues were identified, as was the need for conservation measures (see Davies & Payne, 1982; IUCN SSC, 1982) yet four decades later and there is still an absence of basic ecological data which prohibit the design of a conservation plan. The demographic history of this species echoes that of the Sumatran rhinoceros (*Dicerorhinus sumatrensis*) in Sabah, and now the future persistence of the banteng also hangs in the balance. Baseline information on the occurrence, ecology, behaviour, demography and population genetic structure are essential to create a strategy for conservation management of this subspecies and prevent their imminent extinction. To provide much needed baseline data, I conducted an interdisciplinary study combining common non-invasive ecological sampling and non-invasive molecular methods with analyses able to process data characterised by absences, autocorrelation and sampling bias that are often prevalent in studies on low-density rare species in tropical forests. A heavy investment in fieldwork was required in order to obtain sufficient amounts of data to conduct analyses, and three out of four years were spent in dense tropical forest in Sabah looking for signs of this elusive animal. A systematic approach was taken: first was a compilation of the natural history of banteng in order to assess the research requirements and their conservation significance; I contacted all known researchers on banteng and compiled literature on all three subspecies from past and current research. This information was then used to update the banteng IUCN Red List species assessment which is currently in review. To avoid repetition on the ecology and background, Chapter 2 contains all information on the historic and present-day distribution, status and threats, and ecology of all three subspecies. This thesis is the first extensive and quantitative study of banteng in Sabah. I therefore aimed to identify appropriate and efficient non-invasive survey methods that could be replicated for long-term monitoring and could be implemented by government agencies or researchers. Using the data collected from non-invasive camera trap and sign surveys, I applied a generalised estimation equation and generalised linear model to measure the variation in detection between methods due to site conditions. Photo-identification was then conducted for all individuals and accumulation curves and non-parametric estimators were used for preliminary estimates of population size. Using all camera trap photos, I then characterised banteng activity patterns in

three forests with different post-logging ages, and with non-parametric random simulations I explored their behavioural responses to the variation in biotic conditions at the forest floor level and the structural changes sustained during timber harvesting. Finally, I used non-invasively collected faecal DNA and molecular techniques to identify population structure and to delineate potential management units that will aid conservation of the banteng in Sabah.

1.2 Biogeography of Sabah (Malaysian Borneo)

Borneo is one of the most biologically diverse places on the planet and contains some of the highest species richness throughout the Sunda Shelf; as many as 1,175 tree species are found in Borneo, which is as much as the entire temperate forests of the northern hemisphere (Corlett, 2014). Faunal diversity is estimated to include 260 species of bird, 75 species of amphibian, over 50 species of reptiles. Approximately 75 species of mammal (Garbutt & Prudente 2006), including 13 species of primate found in Borneo (Meijaard & Nijman 2003), as well as wild bearded pig (*Sus barbatus*), numerous deer species, the non-native Asian elephant (*Elephas maximus*), and two severely threatened large mammals, the Sumatran rhinoceros (*Dicerorhinus sumatrensis*) and banteng or tembadau (*Bos javanicus lowi*) (Payne et al., 1985).

Borneo is situated on the edge of Wallace's line that represents a faunal boundary dividing Asia from the Melanesia archipelago and Australia by deep sea trenches that prohibited terrestrial species dispersal. The island straddles the equator and is characterised by tropical climates year-round with humidity exceeding 95% during two distinct seasons (dry and monsoon). Borneo's position on the Eurasian plate means it does not experience severe tectonic activity unlike the neighbouring Indonesian archipelago. The island comprises three countries: Malaysia (Sarawak and Sabah), Indonesia (Kalimantan) and Brunei. This thesis focuses on the Malaysian state of Sabah, which is located just north of the equatorial border. Sabah shares terrestrial borders with Kalimantan (Indonesia) and Sarawak (Malaysia). Sabah is characterised by a diverse array of endemic fauna and flora with highly productive forests that include old-growth lowland, hill and montane dipterocarp forests, freshwater and peat swamp forest, and mangrove forests. These support the very rare, endemic and secretive large bovid, the banteng. Little is known about its ecology, behaviour, habitat preferences, population structure and evolutionary history and it is unmanaged and unmonitored within

the areas it occurs. Based on forest cover four decades ago, forest area has declined by 39.5% between 1973 and 2010; the most severe loss recorded for the whole of Borneo (Gaveau et al., 2014). Deforestation paved the way for exploitation of the fertile substrate for large-scale monoculture of staple crops which proliferate across the state, comprising oil palm (*Elaeis guineensis*) rubber (*Hevea brasiliensis*) and commercial timber production of non-native fast-growing species (*Acacia/Eucalyptus* species and hybrids) (Gaveau et al., 2014). This has resulted in a highly fragmented landscape but has also opened-up previously-remote forest, which has facilitated rampant hunting of banteng and other large rare mammals for sport, consumption and medicinal properties. Trophies dating back over 40 years are still evident in remote villages within the interior of Sabah (Figure 1.1), and evidence of present-day hunting continues to be documented by researchers today.

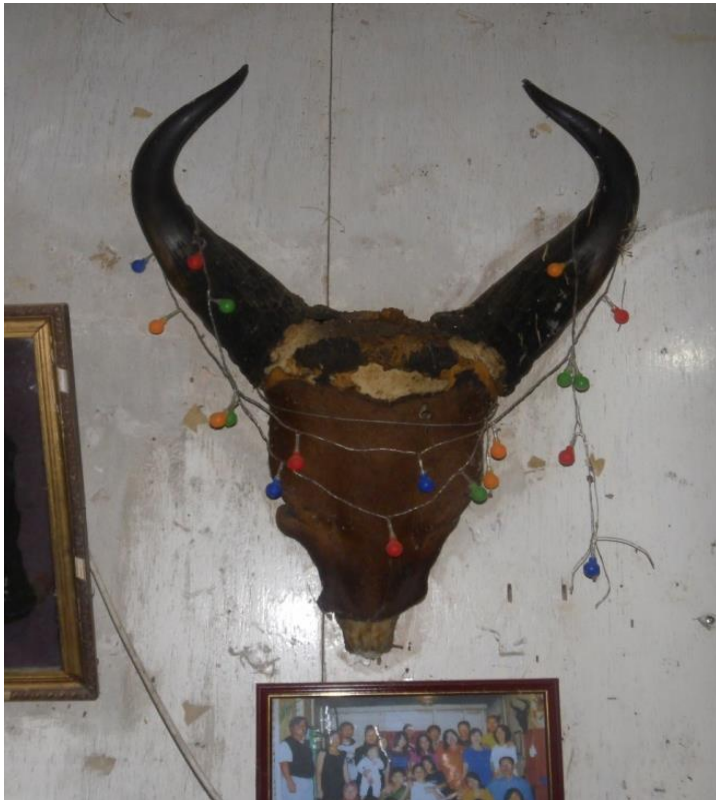

Figure 1.1: Evidence of past hunting activity of banteng in Sabah: Photograph of a trophy head of *B. j. lowi* located in a long house in Long Pasia village (interior of Sabah) which was shot over 40 years ago by the village chief in the surrounding forest. The trophy head was recorded during a state-wide survey to confirm the presence of remnant populations of banteng (© Penny C. Gardner).

Within Sabah, two protected forest reserves, known to contain banteng, were selected for this study: Tabin Wildlife Reserve and Malua Forest Reserve which are situated in the east and central regions of Sabah, respectively. In July 2013 the author commenced fieldwork for a second project documenting the state-wide distribution of banteng in Sabah, and data arising from this (i.e. camera traps and/or faecal samples) became available towards the end of 2013. Therefore, the addition of information from two other forest reserves (Ulu-Segama Malua Forest Reserve and Maliau Basin Conservation Area) supplements this thesis (Chapter 3 and Chapter 4). For clarity, each data chapter details the specific study sites used in the

methods section.

1.3 Taxonomic classification of the study species

The order Artiodactyla or even-toed ungulates of the Bovidae family consist of some of the most culturally and economically important cattle species in the world (MacEachern et al., 2009) with complex phylogenetic histories due to natural and artificial selection, namely the domestication of cattle through a few domestication events (extinct wild auroch *Bos primigenius primigenius*) some 8,000 years ago, which have given rise to numerous breed types (Gautier et al., 2010). The Bovini tribe (Bovidae family and Bovinae subfamily) comprises domestic cattle and a number of little-known wild species which are threatened

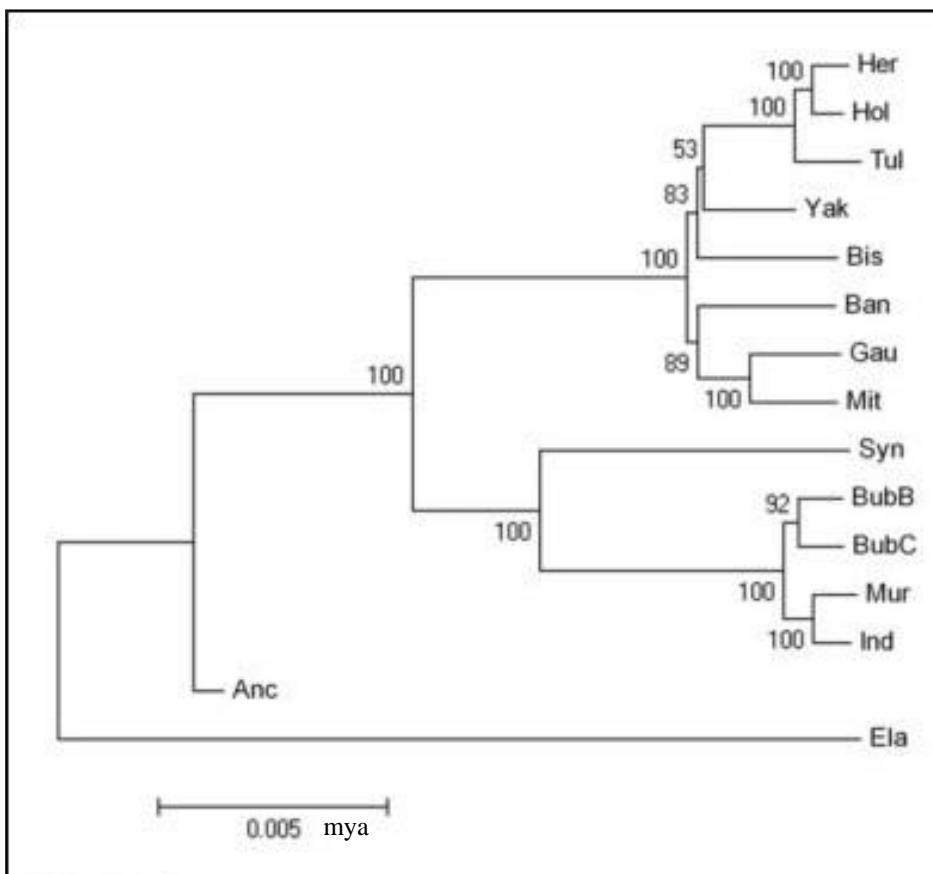

Figure 1.2: A Neighbour-Joining phylogenetic tree of *Bos* from MacEachern et al., 2009 based on mitochondrial (mtDNA) lineages from 15 genes to illustrate the evolutionary history of the Bovini genera. Branch support is indicated at nodes in percentage frequencies (%) using 5,000 bootstraps. The reconstruction suggests the banteng (*Ban*) originates from the same clade as the gaur (*Gau*) and yak (*Yak*) and therefore are more closely related. The species outgroup used to initiate the model was the African antelope eland (*Ela*). Other species included were: Anc: Ancient (Aurochs or *Bos primigenius*), Bis: Bison, BubB & BubC: Asian buffalo, Mit: Mithan, Hol: Holstein, Syn: African buffalo, Tul: Tuli, Herd: Hereford, Mur & Ind: Indian water buffalo, Note: scale bar is millions of years (mya).

with extinction (Janecek et al., 1996; MacEachern et al., 2009), including banteng (*Bos javanicus*). From previous genome-wide analysis, the banteng was identified as being most closely related to the Indian gaur (*Bos gaurus*:

found in mainland Southeast Asia) (Figure 1.2) (Rosli et al., 2011; MacEachern et

al., 2009). Indeed, analogous with gaur, banteng have starkly white lower legs with a muscular compact body but are smaller in stature than gaur. Subtle pelage differences are evident among the three banteng subspecies: *Bos javanicus javanicus*, *Bos javanicus birmanicus* and *Bos javanicus lowi* or *lowii* (hereon referred to as *B. j. lowi*) (Figure 1.3).



Figure 1.3: Photographs of banteng bulls of the three subspecies with subtle variations in pelage colour and body size: Top left: The Bornean banteng (*B. j. lowi*) with very dark pelage colouration and a stout compact body size, photographed in Malua Forest Reserve in Malaysian state of Sabah as part of this study (© Danau Girang Field Centre/Sabah Wildlife Department: P. Gardner). Top right: A banteng bull in Thailand (*B. j. birmanicus*) with a brown pelage and heavy-set facial features (© D. Kohn). Bottom: A herd of Javan banteng (*B. j. javanicus*) photographed on the Indonesian island of Java with the bulls evident by their dark brown/black pelage colour. The facial structure of the Javan banteng shows subtle differences in their elongated facial structure (© S. Pudyamtoko).

These occur in different regions that are not currently linked by land (Hassanin & Ropiquet 2007; Matsubayashi et al., 2014; Janecek et al., 1996): *B. j. javanicus* is found on the Indonesian islands of Java and Bali, *B. j. birmanicus* on mainland Southeast Asia (Cambodia, Vietnam, Laos, Thailand, Myanmar and China) and lastly *B. j. lowi* on the island of Borneo (Figure 1.4).

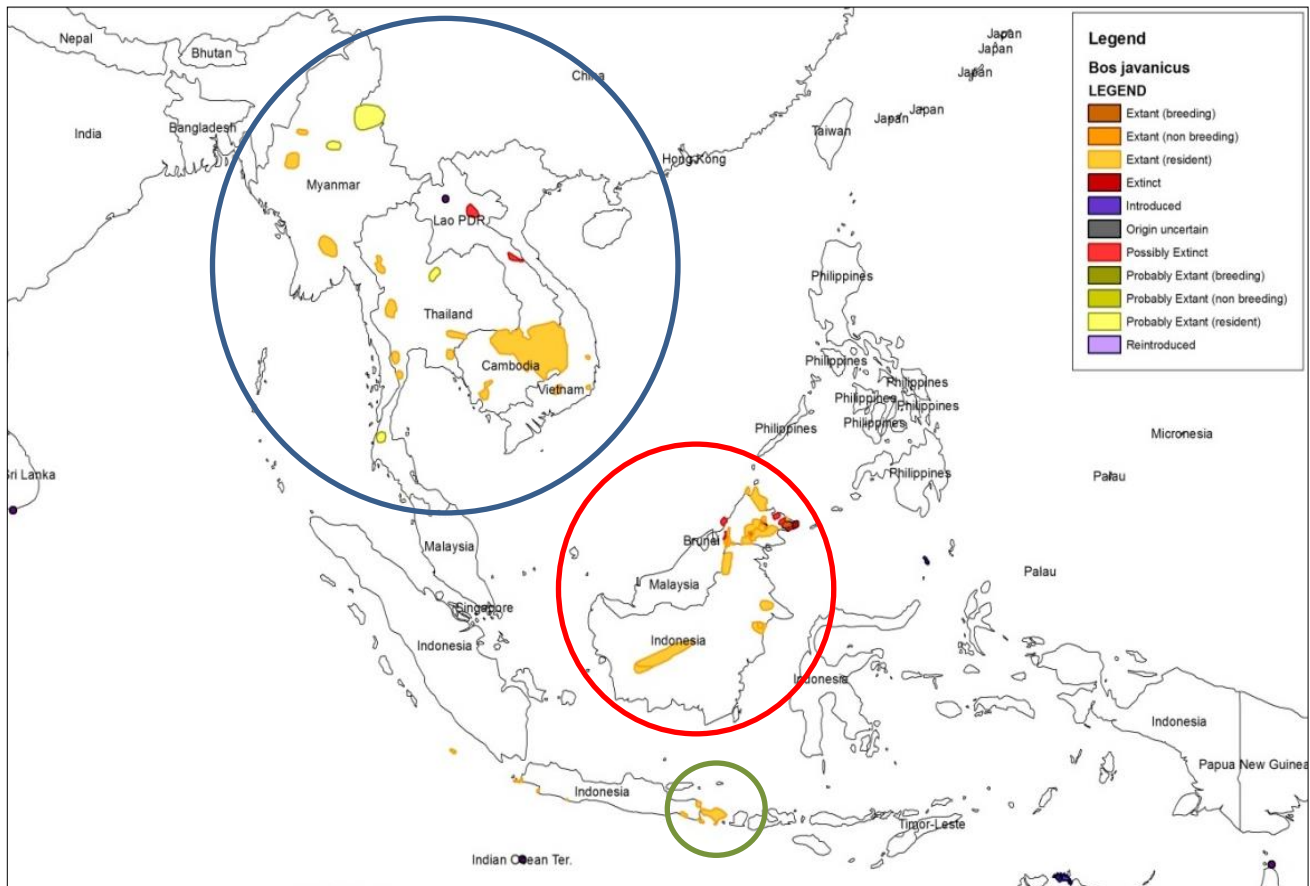

Figure 1.4: The world-wide distribution of *Bos javanicus* with areas of recent extinctions arising from land-use conversion and eradication by hunting and also confirmed remnant populations previously undocumented. This map is an updated version of the IUCN Red List of Threatened Species assessment which is currently under review, and the review may possibly endorse the change of subspecies *B. j. birmanicus* in Kalimantan (Indonesian, Borneo) to *B. j. lowi* based on a lack of evidence within the literature (Gardner et al., n.d.). Distribution of subspecies: Mainland banteng *B. j. birmanicus* (blue circle), Bornean banteng *B. j. lowi* (red circle), and Javan banteng *B. j. javanicus* (green circle)

The banteng is likely to be a monophyletic species that dispersed across the Sunda shelf (land bridges) connecting the Malayan and Indo-Malayan sub-region during the last glacial period (maximum 22,00-19,000 years ago (Yokoyama et al., 2000). Prehistoric cave paintings dating <10,000 years ago depicting zoomorphic figures, including one animal which is thought to be the banteng (Figure 1.5) (Chazine 2005; Chazine 2009), and bone fragments of wild cattle, believed to be banteng, found in a cave in Sarawak that were dated to the late-Pleistocene period (Medway 1964) suggest the banteng naturally occurs in Borneo. Wallace (1876) identified similarities in fauna between the regions mentioned above, and since this time many bio-geographers have come to the conclusion of wide faunal exchange among these islands (e.g. Lim & Sheldon 2011).



Figure 1.5: Prehistoric cave art of an animal which is thought to be the banteng, found in a cave in Kalimantan (Indonesian, Borneo) during a caving expedition by a French-Indonesia team in 1994. The paintings are thought to date >10,000 years ago which may corroborate the dispersal of the banteng across the Sunda shelf during the last glacial maximum between 22,000-19,000 years ago (Chazine 2005).

For the banteng, the genetic identities of many populations are yet to be confirmed and this has resulted in confusion over the distribution of subspecies. For example, *B. j. birmanicus* is currently listed as present in Kalimantan (see Timmins et al., 2008) however there is no molecular evidence or historical records that suggests any subspecies other than *S. j. lowi* may be present in Borneo. Further complications arise also from past introgression with domestic cattle in protected forests (e.g. Deramakot Forest Reserve in Sabah where domestic cattle were abandoned at logging camps following completion of timber harvesting (R. Corpus, pers. comm.) and the origin of the seemingly wild populations. Due to the difficulties in obtaining DNA of *B. j. lowi*, their phylogeny and relationship remain largely unexplored. The most recent attempt to identify the phylogeny of banteng in Sabah support the theory that they have genetically diverged from their ancestors over time and do indeed belong to a distinct subspecies (see Matsubayashi et al., 2014). However, the phylogeny of *B. j. lowi* and the distinction of (2) mitochondrial haplotypes was limited by the number of samples available (24) for analysis and the DNA fragment lengths used, 277bp from the mitochondrial cytochrome-*b* gene and 253bp from the mitochondrial control region, leaving scope for additional analyses and clarification to delineate *B. j. lowi*.

1.4 Ecological non-invasive population studies

1.4.1 Non-invasive sampling methods

Rapid and reliable estimations of population sizes are needed for efficient monitoring of animal populations of conservation concern so that appropriate management can be implemented (Mackenzie & Nichols 2004; Wanger et al., 2008). However, reliable information on the distributions, habitat associations and community dynamics of rare, cryptic and nocturnal species is difficult to acquire (Swan et al., 2013). Standardised field-surveys of large mammals are notoriously difficult to execute in tropical moist forests (Espartosa et al., 2011), and the choice of method has a large influence over the accuracy of population parameter estimates and the breadth of the research conclusions (Garden et al., 2007). Method choice should be therefore be an informed decision based on the relative performance of the techniques used (Espartosa et al., 2011). Ecological non-invasive sampling methods (e.g. camera trapping, hair snares, sign surveys and distance-based measures of direct observations) are important for studying population parameters of forest ungulates (e.g. sambar (*Rusa unicolor*) and red muntjac (*Muntiacus muntjak*), Chinese serow (*Capricornis milneedwardsii*), wild pig (*Sus scrofa*) and gaur (Jathanna et al., 2003; Kamler

et al., 2012; Li et al., 2013), Harvey's duiker (*Cephalophus harveyi*) (Rovero & Marshall 2009), and Sumatran rhinoceros (*R. sondaicus*) (Brook et al., 2012). Direct observations have been used to estimate density and occupancy of *B. j. birmanicus* in Cambodia (e.g. Gray et al., 2012; Gray, 2012) and to describe behavioural characteristics of *B. j. javanicus* in Java (e.g. Hoogerwerf, 1970). In theory, this method may be suitable for surveying Sabah's population however a lack of past direct sightings together with poor visibility because of dense vegetation suggests this method may be unsuitable. Camera traps have been used for estimating activity patterns and habitat preferences of *B. j. birmanicus* in Cambodia (Gray & Phan, 2011), activity patterns of *B. j. javanicus* in Java (e.g. van Schaik, 1996) and seed dispersal and use of mineral licks by *B. j. lowi* in Sabah (Lagan et al., 2007; Matsubayashi et al., 2007). A very recent camera trap study by Brodie et al., (2015) used occupancy modelling to assess the behavioural responses of large mammals to logging and edge effects. However, my analysis of the banteng images from Brodie et al., (2014) (included in Chapter 3 of this thesis) showed the same individuals were captured repeatedly at different sampling sites (termed autocorrelation), therefore violating model assumptions (explored in further detail below). Non-invasive hair sampling traps have been used to collect hair from a range of taxa such as a mesocarnivore population in Europe (Monterroso et al., 2013), red fox (*Vulpes Vulpes*) (Vine et al., 2009), otter (*Lutra lutra*) (Hájková et al., 2009), black bear (*Ursus americanus*) (Gardner et al., 2010) and deer (*Odocoileus virginianus*) (Belant et al., 2007). Adaptation of barbed wire traps used to sample deer hair (Belant et al., 2007) may be possible for the banteng although they may be ethically unsuitable due to the injury they may cause.

1.4.2 Sampling efficiency and population parameter estimation

Sampling schemes for rare species are highly challenging because there is often little information available on their ecology to inform study design. The resulting data has a tendency to be scarce and highly porous; issues that confound statistical analysis (Sollmann et al., 2013). Camera trap capture data is inherently autocorrelated over time and, whilst it is possible to greatly reduce this by adhering to strict predefined measures of independence (i.e. sampling distances representative of home range sizes and maintaining a closed sampling season), the essence of the data is binary longitudinal (i.e. repeated measures of presence/absence over time) (Akanda & Alpizar-Jara 2014). Clustered sampling units also frequently arise, particularly in wildlife studies that collect longitudinal data (i.e. repeated observations over time) using camera traps. Such data has is potentially a) non-independent

and b) correlated (Pardo & Alonso, 2014; Rotheray et al., 2008; Vaughan et al., 2007). In addition to autocorrelation, camera trap datasets, particularly of little-known tropical low-density species like the banteng, are biased by imperfect detection (Royle et al., 2005), whereby target species may be truly absent (i.e. individuals are not available for detection) (Stanley & Royle 2005) or they may be inconsistently detected due to a variety of factors such as availability at a given site at a specific time/date, abundance, climatic or site conditions, and species body-mass (see Mackenzie 2006). These datasets also tend to be zero-inflated which limit the type of analyses that can be performed.

Statistical methods commonly used to compare the success of detection by multiple survey methods to identify the diversity of taxa detected within an ecosystem include chi-squared test and Spearman rank correlation (Lyra-Jorge et al., 2008; Tobler et al., 2008). Other methods used to analyse presence/absence data, and interpolation and extrapolation of population parameters estimates include the following techniques:

1) Occupancy modelling

Occupancy modelling is an alternative method that is based on a history of binary presence or absence data and site-specific covariates (Mackenzie et al., 2002). This method is advantageous because the model provides a flexible framework enabling missing data and inclusion of covariate information that can be collected using a wide variety of survey methods (Mackenzie et al., 2010). A recent surge in studies has used occupancy modelling for estimating detection probability of survey methods whilst also estimating the probability of occupancy. Various survey methods have been used to estimate occupancy: hair snares (Monterroso et al., 2013), tracks along transects and in a grid (Guillera-Arroita et al., 2011; Vongkhamheng et al., 2013), camera traps (Monterroso et al., 2013; Thorn et al., 2009; Wong et al., 2013), and direct sightings (Vongkhamheng et al., 2013; Brown et al., 2012). Occupancy modelling has been applied to camera trap data of banteng and gaur in Cambodia (Gray 2012). However, as only one survey method was used it was not possible to identify if detection probabilities were optimal and if it was an effective method for surveying banteng. Occupancy modelling of banteng is presently hindered by a lack of ancillary information on home range size, dispersal distances and the timing of a breeding season, which are required to design a sampling scheme which does not violate occupancy assumptions. These include the assumption of closure (no emigration or immigration during the survey), independent

sampling of individuals (i.e. knowledge of the home range size to prevent sampling the same individual multiple times), and consistent detection of the target species (i.e. no false detections when absent or incorrect identification of the species) (Mackenzie et al., 2002). If these assumptions are not met, estimators may be biased and inferences may be incorrect (Mackenzie et al., 2006). For the banteng, the shortage of ancillary data is currently a hindrance, and modelling population parameters based on speculation of such basic information may result in futile surveys. Furthermore, data from surveys may be sparse and a large number of absences is highly problematic even for software designed to handle binomial data (e.g. Occupancy modelling). In such cases stratification of the data (i.e. partitioning of presence/absence data into more surveys) is essential to ensure sufficient positive values are available to run a model (D. MacKenzie, pers. comm.).

2) Capture-recapture modelling

Capture-recapture (CR) models are a more traditional method for estimating wildlife population parameters (Sollmann et al., 2013), and were developed to tackle difficulties associated with estimation of population size in mobile animals (Petit & Valiere 2006). CR is based on a binary history of presence/absence data of recognisable or marked individuals and, in the simplest model, the population size can be estimated from the ratio of marked to unmarked individuals in recapture sessions assuming that all individuals randomly mix after the first capture event (Petit & Valiere 2006). Variation in detection can be incorporated (O'Connell et al., 2011) as (e.g.) distance of each individual to the trap (Gardner et al., 2009). CR is generally not suited for individuals that cannot be identified but when marking or identification is possible, CR is advantageous for species that are rarely encountered, furthermore it can be applied in conjunction with other methods (i.e. occupancy modelling and species accumulation curves). However, the same critical assumptions previously mentioned must be adhered to when developing accurate models.

3) Generalised Estimation Equations and Generalised Linear Models (GEEGLM)

Generalised estimation equations (GEE) fitted via a generalised linear model (GLM) provides a suitable alternative to modelling autocorrelated binomial data (Rotheray et al., 2008). This is because a GEEGLM is able to account for a correlated structure among capture data whereas traditional approaches are generally limited to analysis of independent observations only (Akanda & Alpizar-Jara 2014). When transformed into an odds ratio, a GEEGLM is potentially easier to interpret than a correlation coefficient (Lipsitz et al., 1991). The application of GEEGLM models in wildlife conservation is not extensive but examples include the odds of mortality in blue shark (*Prionace glauca*) as a consequence of fishing operations, in order to evaluate conservation measures (see Coelho et al., 2013) and habitat-specificity in riparian birds to determine if trends in populations were linked with landscape changes (see Vaughan et al., 2007). GEEGLM modelling has also recently been applied to (trap) capture data to estimate heterogeneity in detection probabilities by using CR histories of individuals (see Akanda & Alpizar-Jara 2014).

4) Species Accumulation Curves (SAC)

Non-parametric individual-based accumulation curves, also known as Species Accumulation Curves (SAC), plot the expected number of detected individuals or species as a function of sampling effort, and are expressed as rarefaction accumulation (RAC) curves to determine an estimated target richness (i.e. 95%) using increments in sampling units (Dey & Chaudhuri 2013). Species-richness estimators (e.g. Chao by Chao et al., (2009)) use incidence-based data to extrapolate the posterior distributions based on random permutations of the prior distribution without replacement (Oksanen et al., 2012). Although originally intended for estimating species richness of communities, accumulation curves can be adapted to fit capture histories for individuals of a single species (e.g. weedy dragons *Phyllopteryx taeniolatus*: Martin-Smith (2011), tiger *Panthera tigris corbetti*: Azlan and Sharma (2003), and giant day gecko *Phelsuma madagascariensis grandis*: Wanger et al., (2008)). This modified approach requires individual identification and a CR history based on markings that 1) provide sufficient information to identify all individuals in the population, providing that 2) markings do not change over time (Martin-Smith 2011). This approach is useful for organisms not sampled randomly or independently, and for studies which cannot conduct exhaustive sampling (Dey & Chaudhuri 2013; Chao et al., 2009). Furthermore, for species

which are poorly understood and lack ecological data and where non-invasive molecular analysis may not be possible, this approach can provide a starting point for estimating preliminary population parameters prior to conducting more rigorous analyses, which requires information on home-range size, fecundity, and social organisation (e.g. capture-recapture models, occupancy modelling).

1.4.3 Activity budgets

The optimal fit of an organism to varying environments must involve some compromise in behaviour between mitigating this variation and tolerating it (Begon et al., 1996). The monitoring of behaviour is a way of measuring such compromise and is crucial for understanding a species (Mohapatra & Panda 2013) and also for assessing the extent of disturbance caused by habitat modification and human encroachment (Marchand et al., 2014), which in-turn can be used to ensure the protection of a species to meet conservation goals (Mohapatra & Panda 2013). For example, repeated disruptions within the habitat can have cumulative negative effects on a species bioenergetics budget, which can be detrimental to individual survival and reproductive rate (Christiansen et al., 2013; Marchand et al., 2014). For example, within tropical forests in Borneo, repeated logging has caused structural changes to the forest canopy and created large gaps unable to be traversed by species such as the arboreal ape orang-utan (*Pongo pygmaeus*). Using camera trap captures Ancrenaz et al., (2014) reported an increase in terrestrial behaviour in orang-utans, potentially increasing susceptibility to predation, human conflict and diseases. Banteng, in addition to numerous other ungulates that coexist with orang-utans, share similar habitat but at ground-level, therefore it is possible the disturbances experienced by orang-utan also cascade across the species community.

Sampling techniques used to study behaviour should be reliable, have a measure of error and be consistent (Mohapatra & Panda 2013). Owing to recent advances in GPS technology and bio-loggers it is now possible to obtain accurate information on compensatory behavioural responses to disturbances (Marchand et al., 2014) however for species that evade human presence and for which capture is not possible, these methods are largely unsuitable because they may not be easily fitted to an individual. Generally speaking, (as previously mentioned) rare species yield only sparse data, which limits the ability to obtain precise parameter estimates and to include potentially important covariates into an analytical model

(Sollmann et al., 2013). For the above reasons a considerable amount of time and effort is required to ensure statistical tests can give reasonable estimates of relevant parameters (O'Connell et al., 2011). In many instances the raw data of tropical forest mammals is used to infer activity patterns (e.g. Gray & Phan 2011; Ross et al., 2013) without statistical modelling. However, simulations of the observed data and covariates, with or without replacement of observations, is advantageous because the simulated data set can remove any underlying structure and it can be used to obtain confidence intervals around each estimate (Sollmann et al., 2013). Bootstrapping is suitable for sparse data sets on rare species such as the banteng because it can maximise the potential of a small data set and address ecological questions, which might otherwise be limited to descriptions of raw data. Bootstrapping of observed data sets has been employed in various studies of behaviour to document the effects of temperature and sun exposure on the activity budget of chimpanzees (*Pan troglodytes*) (Kosheleff & Anderson 2009), temporal avoidance of ungulate prey species (Ross et al., 2013), and the effects of seasonality and a changing environment upon activity patterns of wild ungulates (Owen-Smith & Goodall 2014; Allred et al., 2013). With well thought-out stratification of the data into groupings that best represent the species' behaviour and biology (Owen-Smith et al., 2010), it is possible to address more sophisticated questions about behaviour.

1.5 Conservation genetics

Conservation genetics encompasses the use of population genetics theory (Shafer et al., 2014) and molecular and statistical techniques to identify and reduce the risk of extinction in threatened species (Frankham et al., 2010; Beebee & Rowe 2008). Taxonomic identification of the threatened species is the first step of genetic management, and delineation of the subpopulations closely follows after (Frankham et al., 2010). Species populations can be structured by historic habitat fragmentation and restricted gene-flow, sex-biased dispersal, historic expansions in population size, and hunting which can remove genetic diversity from the gene-pool, and genetic drift (Frankham et al., 2010; Rodrigues 2012; Ferreira da Silva et al., 2014). These trends can be recognised using molecular markers from the nuclear and mitochondrial genomes.

1.5.1 Non-invasive molecular sampling

Baseline genetic information is often an essential prerequisite for developing effective conservation management plans, and in order to address these issues the collection of sufficient quantities of DNA is paramount. To study species which are rare and/or difficult to observe, such as the giant panda (*Ailuropoda melanoleuca*) in China (Zhan et al., 2007), Okapi (*Okapia johnstoni*) in the Democratic republic of Congo (Stanton et al., 2014), orang-utan (*Pongo pygmaeus abelli*) in Sumatra (Goossens et al., 2000) and Guinea baboons (*Papio papio*) in Guinea-Bissau (Ferreira da Silva et al., 2014), non-invasive samples are required (Goossens et al., 2000). In recent years non-invasive genetic sampling has been increasingly applied to the study of wild, elusive species (Zhan et al., 2010) and using DNA retrievable from various kinds of samples, namely shed hair, feathers, and faeces (Broquet et al., 2006; Frankham et al., 2010; Zhan et al., 2010). Non-invasive collection of faecal DNA has been conducted in tropical forests for notable mammalian species and has been advantageous for species with an unpredictable nature (e.g. Asian elephant; Fernando and Lande (2000), arboreal behaviour (e.g. orang-utan; Nater et al., (2011) and Goossens et al., (2000)), and where handling would have resulted in unnecessary elevated stress levels in the species (e.g. clouded leopard (*Neofelis*); Wilting et al., (2011)). However, the technical difficulties inherent to the analysis of low quantities of DNA from non-invasive samples tend to limit the efficiency of this approach (Broquet et al., 2006; Nsubuga et al., 2004). Faecal DNA is typically poor quality and suffers degradation from UV exposure, high humidity and temperature (Soto-Calderón et al., 2009). Storage methods of faecal samples have also been shown to affect amplification success of ungulate and other DNA (Soto-Calderón et al., 2009), and extraction and amplification can also be inhibited by diet content (Broquet et al., 2006). Despite these drawbacks, faecal DNA analysis can be an extremely valuable tool (Soto-Calderón et al., 2009). For the Bornean banteng, non-invasive faecal DNA is presently the only option to study population genetic structure, as prior attempts to biopsy-dart individuals for tissue samples and capture individuals for blood samples were unsuccessful. Only one molecular study of the Bornean banteng has been conducted (see Matsubayashi et al., 2014), which attempted to describe the phylogeny and genetic structure in four forest populations using faecal DNA. Whilst amplification of faecal DNA was successful, the study was hampered by low-levels of amplification success and the final dataset included only a small proportion of samples (23 successfully amplified from a total of 72 samples). Storage methods were not analogous with those found to yield high concentrations of pre and post-

extraction DNA (Nsubuga et al., 2004) and the chosen short fragment sizes reduced the amount of genetic variability available for measurement.

1.5.2 Mitochondrial (mt) DNA

Mitochondrial DNA is one of the most commonly used genetic markers for delineating animal taxa (Frankham et al., 2010) and is located within the mitochondria that are predominately maternally-inherited (Beebee & Rowe 2008). The mitochondrion possess a circular genome (Figure 1.6) which generally does not undergo recombination but contains coding genes (e.g. cytochrome-*b*) and non-coding regions (e.g. control region/d-loop) (Beebee & Rowe 2008; Frankham et al., 2010). The typical mean mutation rate in humans is 10^{-8} per site per generation but if there is unexplained variation the mutation rate of each site will deviate from this value (Eyre-Walker & Eyre-Walker 2014). mtDNA sampled from present-day individuals signifies the presence of historical matriline and can be used to infer population structure, evolutionary history and past population dynamics (Beebee & Rowe 2008). Mitochondrial DNA is also suitable for population genetic studies using non-invasively sampled DNA from rare species because there are often dozens of copies of the mtDNA genome within each mitochondrion and hundreds of mitochondria in each cell, compared to nuclear DNA (where there are only two copies within the nucleus); a consistently higher amplification success was found when using mtDNA versus nuclear DNA from faecal and hair samples from a range of carnivorous and omnivorous taxa (Broquet et al., 2006). Female population structure using mtDNA can be estimated from delineation of haplotypes that genetically differ and mapping these haplotypes (Frankham et al., 2010). The distribution of haplotypes with the geographic locations of samples can reveal barriers to dispersal or gene flow which influenced the structure of the population (e.g. in orang-utans in Borneo which were likely differentiated by river systems; Goossens et al., (2005)).

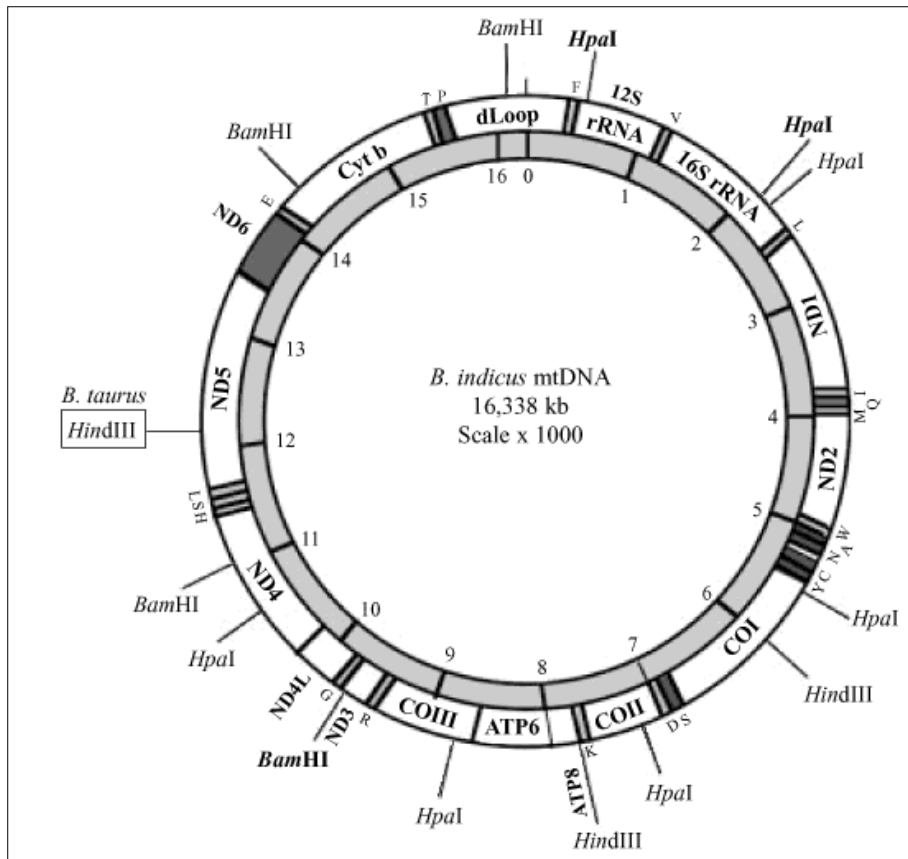

Figure 1.6: The mitochondrial circular genome (mtDNA) of *Bos indicus* which originates from countries with a warm climate (Meirelles et al., 1999). The mtDNA is found within the organelles of cells of eukaryotes, and is divided into genes that code for amino acids and synthesise proteins (cytochrome-*b*) and non-coding region (control region/d-loop). The mtDNA does not recombine but is under selection, and signatures of selection are identical to mutations which are used to define haplotypes. Note, in italics are sites found exclusively in *B. indicus* and (*HindIII*) in *B. taurus* mtDNA.

A handful of studies have attempted to delineate the phylogeny of banteng (*B. j. javanicus* and *B. j. birmanicus*) in relation to other *Bos* species using tissue samples (Hassanin & Ropiquet 2004; Hassanin & Ropiquet 2007; see MacEachern et al., 2009; Ropiquet et al., 2008; Rosli et al., 2011; Nijman et al., 2003) and also recently using non-invasively collected faecal samples (*B. j. lowi*) (see Matsubayashi et al., 2014). The latter is the only example of a molecular study including Bornean banteng, due to the difficulties in obtaining samples. The study by Matsubayashi et al., (2014) attempted to categorise the evolutionary history, phylogeny and population structure of the Bornean banteng using non-invasive mtDNA extracted from faeces and two unconnected short fragments of DNA from the cytochrome-*b* and control region. The study found evidence to support the division of banteng into three subspecies (Bornean, Javan and Burmese) and that banteng, specifically Bornean banteng are

a close relative of the gaur (*B. gaurus*). Two haplotypes were identified from each gene, but the small sample size and small fragment sizes limited the ability to detect haplotype diversity or determine the causes of genetic differentiation resulting from past events (e.g. habitat fragmentation, range expansion, restricted gene flow) (Frankham et al., 2010).

1.6 Aims and hypotheses

The principal aim of this thesis was to collect the first baseline data on the population ecology and population genetic structure of the Bornean banteng in the Malaysian state of Sabah. This information is essential for species management and will underpin the construction of the first conservation action plan for banteng which is planned for 2016. The division of this thesis is based on addressing four fundamental issues with a combination of exploration of preliminary baseline data, descriptive statistics, and quantitative data testing directional hypotheses:

1. To describe the natural history of banteng.

- a. Identify and collate old and new literature on the banteng
- b. Identify paucity in information on banteng which may be addressed by this thesis

2. Identify suitable and effective non-invasive survey methods that are appropriate for long-term monitoring and estimating population parameters.

- a. Detection success of camera traps would be superior when compared to sign surveys
- b. Detection success of sign surveys would increase in relation to survey duration, decrease as elevation increased, decrease in swamp habitat and in a closed canopy
- c. Identify individual banteng using photographic profiles
- d. Estimate population size and the effect of identification heterogeneity (i.e. the ability to identify individuals)
- e. Estimate the number of undetected individuals and additional sampling effort required to observe all individuals.
- f. Estimate realistic population sizes from observed and extrapolated estimates

3. To characterise activity patterns and identify the effect of habitat disturbance upon activity budgets and site use.

- a. Quantify diel activity of banteng to identify differences associated with different logging histories
- b. Identify diel temperature variations of three different logged forests
- c. Banteng mitigate thermal-stress by performing less energetic behaviours for longer periods in the shade during peak temperatures
- d. Investigate activity budgets and use of forest site features
- e. Compile observations of illegal activity (hunting, harvesting, and encroachment) to assess severity of threats to banteng

4. To investigate the population genetic structure of banteng

- a. Estimate ancestral lineage of Bornean banteng in relation to the rest of the *Bos* genus
- b. Identify haplotypes in four forest reserves
- c. Estimate current levels of genetic diversity
- d. Identify conservation management units of banteng in preparation for the forthcoming first management action plan

1.8 References

- Akanda, M.A.S. & Alpizar-Jara, R., 2014. Estimation of capture probabilities using generalized estimating equations and mixed effects approaches. *Ecology and Evolution*, 4(7), pp.1158–65.
- Allred, B.W., Fuhlendorf, S.D., Hovick, T.J., Dwayne Elmore, R., Engle, D.M. & Joern, A., 2013. Conservation implications of native and introduced ungulates in a changing climate. *Global Change Biology*, 19(6), pp.1875–1883.
- Ancrenaz, M., Sollmann, R., Meijaard, E., Hearn, A.J., Ross, J., Samejima, H., Loken, B., Cheyne, S.M., Stark, D.J., Gardner, P.C., Goossens, B., Mohamed, A., Bohm, T., Matsuda, I., Nakabayasi, M., Lee, S.K., Bernard, H., Brodie, J., Wich, S. et al., 2014. Coming down from the trees: Is terrestrial activity in Bornean orangutans natural or disturbance driven? *Scientific Reports*, 4, e4024.
- Beebee, T. & Rowe, G., 2008. *Molecular Ecology*, Oxford: Oxford University Press.
- Begon, M., Harper, J.L. & Townsend, C.R., 1996. *Ecology: Individuals, populations and communities* 3rd ed., Oxford, U.K: Blackwell Science.
- Belant, J.L., Seamans, T.W. & Paetkau, D., 2007. Genetic tagging free-ranging white-tailed deer using hair snares. *Ohio Journal of Science*, 107(4), pp.50–56.
- Brodie, J.F., Giordano, A.J. & Ambu, L., 2015. Differential responses of large mammals to logging and edge effects. *Mammalian Biology*, 80(1), pp.7–13.
- Brook, S.M., van Coeverden de Groot, P., Scott, C., Boag, P., Long, B., Ley, R.E., Reischer, G.H., Williams, A.C., Mahood, S.P., Hien, T.M., Polet, G., Cox, N. & Hai, B.T., 2012. Integrated and novel survey methods for rhinoceros populations confirm the extinction of *Rhinoceros sondaicus annamiticus* from Vietnam. *Biological Conservation*, 155, pp.59–67.
- Broquet, T., Ménard, N. & Petit, E., 2006. Noninvasive population genetics: a review of sample source, diet, fragment length and microsatellite motif effects on amplification success and genotyping error rates. *Conservation Genetics*, 8(1), pp.249–260.
- Brown, C.L., Hardy, A.R., Barber, J.R., Fristrup, K.M., Crooks, K.R. & Angeloni, L.M., 2012. The effect of human activities and their associated noise on ungulate behavior. *PloS One*, 7(7), e40505.
- Chao, A., Colwell, R.K., Lin, C. & Gotelli, N.J., 2009. Sufficient sampling for asymptotic minimum species richness estimators. *Ecology*, 90(4), pp.1125–1133.
- Chazine, J.M., 2009. *Borneo La memoire des grottes* 1st ed., Editions Fage.
- Chazine, J.M., 2005. Rock Art, Burials, and Habitations: Caves in East Kalimantan. *University of Hawai'i Press*, 44(1), pp.219–230.

- Christiansen, F., Rasmussen, M.H. & Lusseau, D., 2013. Inferring activity budgets in wild animals to estimate the consequences of disturbances. *Behavioral Ecology*, 24(6), pp.1415–1425.
- Coelho, R., Infante, P. & Santos, M.N., 2013. Application of Generalized Linear Models and Generalized Estimation Equations to model at-haulback mortality of blue sharks captured in a pelagic longline fishery in the Atlantic Ocean. *Fisheries Research*, 145, pp.66–75.
- Corlett, R., 2014. *The Ecology of Tropical East Asia* 2nd ed., OUP Oxford.
- Davies, G. & Payne, J., 1982. *A faunal survey of Sabah*, World Wildlife Fund - Malaysia.
- Dey, A. & Chaudhuri, P.S., 2013. Quantifying earthworm species richness in the pineapple and mixed fruit plantations of West Tripura, India - A non-parametric approach. *European Journal of Soil Biology*, 59, pp.31–35.
- Espartosa, K.D., Pinotti, B.T. & Pardini, R., 2011. Performance of camera trapping and track counts for surveying large mammals in rainforest remnants. *Biodiversity and Conservation*, 20(12), pp.2815–2829.
- Eyre-Walker, A. & Eyre-Walker, Y.C., 2014. How much of the variation in the mutation rate along the human genome can be explained? *G3: Genes, Genomes, Genetics*, 4(9), pp.1667–70.
- Fernando, P. & Lande, R., 2000. Molecular genetic and behavioral analysis of social organization in the Asian elephant (*Elephas maximus*). *Behavioral Ecology and Sociobiology*, 48(1), pp.84–91.
- Ferreira da Silva, M.J., Godinho, R., Casanova, C., Minhós, T., Sá, R. & Bruford, M.W., 2014. Assessing the impact of hunting pressure on population structure of Guinea baboons (*Papio papio*) in Guinea-Bissau. *Conservation Genetics*, 15(6), pp.1339–1355.
- Frankham, R., Ballou, J. & Briscoe, D., 2010. *Introduction To Conservation Genetics*, Cambridge: Cambridge University Press.
- Garbutt, N. & Prudente, C.J., 2006. *Wild Borneo: The wildlife and scenery of Sabah, Sarawak, Brunei and Kalimantan*, New Holland Publishers Ltd.
- Garden, J.G., McAlpine, C.A., Possingham, H.P. & Jones, D.N., 2007. Using multiple survey methods to detect terrestrial reptiles and mammals: what are the most successful and cost-efficient combinations? *Wildlife Research*, 34(3), pp.218–227.
- Gardner, B., Royle, J.A. & Wegan, M.T., 2009. Hierarchical models for estimating density from DNA mark-recapture studies. *Ecology*, 90(4), pp.1106–15.
- Gardner, B., Royle, J.A., Wegan, M.T., Rainbolt, R.E. & Curtis, P.D., 2010. Estimating black bear density using DNA data from hair snares. *Journal of Wildlife Management*, 74(2), pp.318–325.

- Gardner, P., Hedges, S., Pudyatmoko, S., Gray, T., Timmins, R., Hedges, S., Steinmetz, R., Pattanavibool, A., Burton, J., Duckworth, W., *Bos javanicus*. The IUCN Red List of Threatened Species. www.iucnredlist.org.
- Gautier, M., Laloë, D. & Moazami-Goudarzi, K., 2010. Insights into the genetic history of French cattle from dense SNP data on 47 worldwide breeds. *PLoS One*, 5(9), e13038.
- Gaveau, D.L., Sloan, S., Molidena, E., Yaen, H., Sheil, D., Abram, N.K., Ancrenaz, M., Nasi, R., Quinones, M., Wielaard, N. & Meijaard, E., 2014. Four Decades of Forest Persistence, Clearance and Logging on Borneo K. Bawa, ed. *PLoS One*, 9(7), e101654.
- Goossens, B., Chikhi, L., Jalil, M.F., Ancrenaz, M., Lackman-Ancrenaz, I., Mohamed, M., Andau, P. & Bruford, M.W., 2005. Patterns of genetic diversity and migration in increasingly fragmented and declining orang-utan (*Pongo pygmaeus*) populations from Sabah, Malaysia. *Molecular Ecology*, 14(2), pp.441–56.
- Goossens, B., Chikhi, L., Utami, S., de Ruiter, J. & Bruford, M.W., 2000. A multi-samples, multi-extracts approach for microsatellite analysis of faecal samples in an arboreal ape. *Conservation Genetics*, 1, pp.157–162.
- Gray, T.N.E., 2012. Studying large mammals with imperfect detection: Status and habitat preferences of wild cattle and large carnivores in Eastern Cambodia. *Biotropica*, 44(4), pp.531–536.
- Gray, T.N.E. & Phan, C., 2011. Habitat preferences and activity patterns of the larger mammal community in Phnom Prich Wildlife Sanctuary, Cambodia. *The Raffles Bulletin of Zoology*, 59(2), pp.311–318.
- Gray, T.N.E., Prum, S., Pin, C. & Phan, C., 2012. Distance sampling reveals Cambodia's Eastern Plains Landscape supports the largest global population of the Endangered banteng *Bos javanicus*. *Oryx*, 46(04), pp.563–566.
- Guillera-Arroita, G., Morgan, B.J.T., Ridout, M.S. & Linkie, M., 2011. Species occupancy modeling for detection data collected along a transect. *Journal of Agricultural, Biological, and Environmental Statistics*, 16(3), pp.301–317.
- Hájková, P., Zemanová, B., Roche, K. & Hájek, B., 2009. An evaluation of field and noninvasive genetic methods for estimating Eurasian otter population size. *Conservation Genetics*, 10(6), pp.1667–1681.
- Hassanin, A. & Ropiquet, A., 2004. Molecular phylogeny of the tribe Bovini (Bovidae, Bovinae) and the taxonomic status of the Kouprey, *Bos sauveli* (Urbain 1937). *Molecular Phylogenetics and Evolution*, 33(3), pp.896–907.
- Hassanin, A. & Ropiquet, A., 2007. Resolving a zoological mystery: the kouprey is a real species. *Proceedings of the Royal Society B: Biological sciences*, 274(1627), pp.2849–55.

- Hoogerwerf, A., 1970. *Ujung Kulon, The land of the last Javan Rhinoceros: With local and general data on the most important faunal species and their preservation in Indonesia*, E.J. Brill.
- IUCN SSC, 1982. *Species conservation priorities in the tropical forests of southeast Asia*, Gland, Switzerland. Available at: <https://portals.iucn.org/library/node/5838>.
- Janecek, L., Honeycutt, R., Adkins, R. & Davis, S., 1996. Mitochondrial gene sequences and the molecular systematics of the Artiodactyl subfamily Bovinae. *Molecular Phylogenetics and Evolution*, 6(1), pp.107–119.
- Jathanna, D., Karanth, K.U. & Johnsingh, a. J.T., 2003. Estimation of large herbivore densities in the tropical forests of southern India using distance sampling. *Journal of Zoology*, 261(3), pp.285–290.
- Kamler, J.F., Johnson, A., Vongkhamheng, C. & Bousa, A., 2012. The diet, prey selection, and activity of dholes (*Cuon alpinus*) in northern Laos. *Journal of Mammalogy*, 93(3), pp.627–633.
- Kosheleff, V.P. & Anderson, C.N.K., 2009. Temperature's influence on the activity budget, terrestriality, and sun exposure of chimpanzees in the Budongo Forest, Uganda. *American journal of physical anthropology*, 139(2), pp.172–81.
- Lagan, P., Mannan, S. & Matsubayashi, H., 2007. Sustainable use of tropical forests by reduced-impact logging in Deramakot Forest Reserve, Sabah, Malaysia. *Ecological Research*, 22(3), pp.414–421.
- Li, X., Buzzard, P. & Jiang, X., 2013. Habitat associations of four ungulates in mountain forests of southwest China, based on camera trapping and dung counts data. *Population Ecology*, 56(1), pp.251–256.
- Lim, H.C.. b & Sheldon, F.H., 2011. Multilocus analysis of the evolutionary dynamics of rainforest bird populations in Southeast Asia. *Molecular Ecology*, 20(16), pp.3414–3438.
- Lipsitz, S.R., Laird, N.M. & Harrington, D.P., 1991. Generalized Estimating Equations for Correlated Binary Data: Using the Odds Ratio as a Measure of Association. *Biometrika*, 78(1), p.153.
- Lyra-Jorge, M.C., Ciocheti, G., Pivello, V.R. & Meirelles, S.T., 2008. Comparing methods for sampling large-and medium-sized mammals: camera traps and track plots. *European Journal of Wildlife Research*, 54(4), pp.739–744.
- MacEachern, S., McEwan, J. & Goddard, M., 2009. Phylogenetic reconstruction and the identification of ancient polymorphism in the Bovini tribe (Bovidae, Bovinae). *BMC genomics*, 10, e177.
- Mackenzie, D.I., 2006. Modeling the Probability of Resource Use: The Effect of, and dealing with, detecting a species imperfectly. *Journal of Wildlife Management*, 70(2), pp.367–374.

- Mackenzie, D.I. & Nichols, J.D., 2004. Occupancy as a surrogate for abundance estimation. *Animal Biodiversity and Conservation*, 27(1), pp.461–467.
- Mackenzie, D.I., Nichols, J.D., Hines, J.E., Knutson, M.G. & Franklin, A.B., 2010. Estimating site occupancy, colonization, and local extinction when a species is detected imperfectly. *Ecology*, 84(8), pp.2200–2207.
- Mackenzie, D.I., Nichols, J.D., Lachman, G.B., Droege, S., Royle, A.J. & Langtimm, C.A., 2002. Estimating site occupancy rates when detection probabilities are less than one. *Ecology*, 83(8), pp.2248–2255.
- Mackenzie, D.I., Nichols, J.D., Royle, J.A., Pollock, K.H., Bailey, L.L. & Hines, J.E., 2006. *Occupancy estimation and modelling*, Academic Press.
- Marchand, P., Garel, M., Bourgoïn, G., Dubray, D., Maillard, D. & Loison, A., 2014. Impacts of tourism and hunting on a large herbivore's spatio-temporal behavior in and around a French protected area. *Biological Conservation*, 177, pp.1–11.
- Martin-Smith, K.M., 2011. Photo-identification of individual weedy seadragons *Phyllopteryx taeniolatus* and its application in estimating population dynamics. *Journal of fish biology*, 78(6), pp.1757–68.
- Matsubayashi, H., Hanzawa, K., Kono, T., Ishige, T., Gakuhari, T., Lagan, P., Sunjoto, I., Sukor, J.R.A., Sinun, W. & Ahmad, A.H., 2014. First molecular data on Bornean banteng *Bos javanicus lowi* (Cetartiodactyla, Bovidae) from Sabah, Malaysian Borneo. *Mammalia*, pp.1–9.
- Matsubayashi, H., Lagan, P. & Jum Rafiah, S., 2007. Herbal seed dispersal by the banteng in Borean tropical rainforest. *Malaysian Nature Journal*, 59(4), pp.297–303.
- Medway, L., 1964. Post-Pleistocene changes in the mammalian fauna of Borneo. *Studies in Speleology*, 1, pp.33–37.
- Meijaard, E. & Nijman, V., 2003. Primate Hotspots on Borneo: Predictive Value for. *Conservation Biology*, 17(3), pp.725–732.
- Mohapatra, R.K. & Panda, S., 2013. Behavioural sampling techniques and activity pattern of Indian Pangolin *Manis crassicaudata* (Mammalia : Manidae) in captivity. *Journal of Threatened Taxa*, 5(December), pp.5247–5255.
- Mohd-Azlan, J., 2003. Camera trapping the Indochinese tiger, *Panthera tigris corbetti*, in a secondary forest in peninsular Malaysia. *Raffles Bulletin of Zoology*, 51(2), pp.421–427.
- Monterroso, P., Rich, L.N., Serronha, A., Ferreras, P. & Alves, P.C., 2014. Efficiency of hair snares and camera traps to survey mesocarnivore populations. *European Journal of Wildlife Research*, 60(2), pp.279–289.
- Nater, A., Nietlisbach, P., Arora, N., van Schaik, C.P., van Noordwijk, M. a, Willems, E.P., Singleton, I., Wich, S. a, Goossens, B., Warren, K.S., Verschoor, E.J., Perwitasari-Farajallah, D., Pamungkas, J. & Krützen, M., 2011. Sex-biased dispersal and volcanic

- activities shaped phylogeographic patterns of extant Orangutans (genus: Pongo). *Molecular Biology and Evolution*, 28(8), pp.2275–88.
- Nijman, I.J., Otsen, M., Verkaar, E.L.C., de Ruijter, C., Hanekamp, E., Ochieng, J.W., Shamshad, S., Rege, J.E.O., Hanotte, O., Barwegen, M.W., Sulawati, T. & Lenstra, J. a, 2003. Hybridization of banteng (*Bos javanicus*) and zebu (*Bos indicus*) revealed by mitochondrial DNA, satellite DNA, AFLP and microsatellites. *Heredity*, 90(1), pp.10–6.
- Nsubuga, M., Robbins, M.M., Roeder, D., Morin, P., Boesch, C. & Vigilant, L., 2004. Factors affecting the amount of genomic DNA extracted from ape faeces and the identification of an improved sample storage method. *Molecular Ecology*, 13(7), pp.2089–94.
- O'Connell, A.F., Nichols, J.D. & Karanth, K.U., 2011. *Camera Traps in Animal Ecology: Methods and Analyses*, Tokyo: Springer.
- Oksanen, J.F., Blanchet, G., Kindt, R., Legendre, P., Minchin, P.R., O'Hara, R.B., Simpson, G.L., Solymos, P., Stevens, M. & Wagner, H., 2012. Vegan: Community Ecology Package. Available at: <http://cran.r-project.org/web/packages/vegan/index.html>.
- Owen-Smith, N., Fryxell, J.M. & Merrill, E.H., 2010. Foraging theory upscaled: the behavioural ecology of herbivore movement. *Philosophical Transactions of the Royal Society of London. Series B, Biological Sciences*, 365(1550), pp.2267–78.
- Owen-Smith, N. & Goodall, V., 2014. Coping with savanna seasonality: comparative daily activity patterns of African ungulates as revealed by GPS telemetry. *Journal of Zoology*, 293(3), pp.181–191.
- Pardo, M.C. & Alonso, R., 2014. GEEs for repeated categorical responses based on generalized residuals. *Journal of Statistical Computation and Simulation*, 84(2), pp.344–359.
- Payne, J., Francis, C.M., Phillips, S.S. & WWF-Malaysia, 1985. *A field guide to the mammals of Borneo*, Kota Kinabalu: The Sabah Society, Malaysia.
- Petit, E. & Valiere, N., 2006. Estimating population size with noninvasive capture-mark-recapture data. *Conservation Biology*, 20(4), pp.1062–1073.
- Rodrigues, T.M., 2012. *Socio-genetics and population structure of two African colobus monkeys in Cantanhez National Park, Guinea Bissau*. PhD thesis, Cardiff University.
- Ropiquet, A., Gerbault-Seureau, M., Deuve, J.L., Gilbert, C., Pagacova, E., Chai, N., Rubes, J. & Hassanin, A., 2008. Chromosome evolution in the subtribe Bovina (Mammalia, Bovidae): the karyotype of the Cambodian banteng (*Bos javanicus birmanicus*) suggests that Robertsonian translocations are related to interspecific hybridization. *Chromosome Research*, 16(8), pp.1107–18.
- Rosli, M.K.A., Zakaria, S.S., Syed-Shabthar, S.M.F., Zainal, Z.Z., Shukor, M.N., Mahani, M.C., Abas-Mazni, O. & Md-Zain, B.M., 2011. Phylogenetic relationships of Malayan

- gaur with other species of the genus *Bos* based on cytochrome b gene DNA sequences. *Genetics and Molecular Research*, 10(1), pp.482–93.
- Ross, J., Hearn, J., Johnson, P.J. & Macdonald, D.W., 2013. Activity patterns and temporal avoidance by prey in response to Sunda clouded leopard predation risk. *Journal of Zoology*, 290(2), pp.96–106.
- Rotheray, T.D., Jones, T.H., Fricker, M.D. & Boddy, L., 2008. Grazing alters network architecture during interspecific mycelial interactions. *Fungal Ecology*, 1(4), pp.124–132.
- Rovero, F. & Marshall, A.R., 2009. Camera trapping photographic rate as an index of density in forest ungulates. *Journal of Applied Ecology*, 46(5), pp.1011–1017.
- Royle, J.A., Nichols, J.D. & Kery, M., 2005. Modelling occurrence and abundance of species when detection is imperfect. *Oikos*, 2(110), pp.353–359.
- Van Schaik, C.P., 1996. Activity periods of Indonesian rain forest mammals. *Biotropica*, 28(1), pp.105–112.
- Shafer, A.B., Wolf, J.B.W., Alves, P.C., Bergström, L., Bruford, M.W., Brännström, I., Colling, G., Dalén, L., De Meester, L., Ekblom, R., Fawcett, K.D., Fior, S., Hajibabaei, M., Hill, J., Hoebel, R., Höglund, J., Jensen, E.L., Krause, J., Kristensen, T.N. et al., 2015. Genomics and the challenging translation into conservation practice. *Trends in Ecology & Evolution*, 30(2), pp.78–87.
- Sollmann, R., Tôrres, N.M., Furtado, M.M., de Almeida Jácomo, A.T., Palomares, F., Roques, S. & Silveira, L., 2013. Combining camera-trapping and noninvasive genetic data in a spatial capture–recapture framework improves density estimates for the jaguar. *Biological Conservation*, 167, pp.242–247.
- Soto-Calderón, I.D., Ntie, S., Mickala, P., Maisels, F., Wickings, E.J. & Anthony, N.M., 2009. Effects of storage type and time on DNA amplification success in tropical ungulate faeces. *Molecular Ecology Resources*, 9(2), pp.471–9.
- Stanley, T.R. & Royle, J.A., 2005. Estimating site occupancy and abundance using indirect detection indices. *Journal of Wildlife Management*, 69(3), pp.874–883.
- Stanton, D.W.G., Hart, J., Galbusera, P., Helsen, P., Shephard, J., Kümpel, N.F., Wang, J., Ewen, J.G. & Bruford, M.W., 2014. Distinct and diverse: range-wide phylogeography reveals ancient lineages and high genetic variation in the endangered okapi (*Okapia johnstoni*). *PloS One*, 9(7), e101081.
- Swan, M., Stefano, J., Christie, F., Steel, E. & York, A., 2014. Detecting mammals in heterogeneous landscapes: implications for biodiversity monitoring and management. *Biodiversity and Conservation*, 23(2), pp.343–355.
- Thorn, M., Scott, D.M., Green, M., Bateman, P.W. & Cameron, E.Z., 2009. Estimating brown hyaena occupancy using baited camera traps. *South African Journal of Wildlife Research*, 39(1), pp.1–10.

- Timmins, R.J., Duckworth, J.W., Hedges, S., Steinmetz, R. & Pattanavibool, A., 2008. *Bos javanicus*. In: IUCN 2012. IUCN Red List of threatened species. www.iucnredlist.org. Available at: www.iucnredlist.org/details/biblio/2888/0.
- Tobler, M.W., Carrillo-Percegué, S.E., Leite Pitman, R., Mares, R. & Powell, G., 2008. An evaluation of camera traps for inventorying large- and medium-sized terrestrial rainforest mammals. *Animal Conservation*, 11(3), pp.169–178.
- Vaughan, I.P., Noble, D.G. & Ormerod, S.J., 2007. Combining surveys of river habitats and river birds to appraise riverine hydromorphology. *Freshwater Biology*, 52(11), pp.2270–2284.
- Vine, S., Crowther, M., Lapidge, S., Dickman, C., Mooney, N., Piggott, M. & English, A., 2009. Comparison of methods to detect rare and cryptic species: A case study using the red fox (*Vulpes vulpes*). *Wildlife Research*, 36(5), pp.436–446.
- Vongkhamheng, C., Johnson, A. & Sunquist, M., 2013. A baseline survey of ungulate abundance and distribution in northern Lao: Implications for conservation. *Oryx*, 47(4), pp.544–552.
- Wallace, A.R., 1876. *The geographical distribution of animals*, New York: Harper and Brothers.
- Wanger, T.C., Motzke, I., Furrer, S.C., Brook, B.W. & Gruber, B., 2008. How to monitor elusive lizards: comparison of capture–recapture methods on giant day geckos (Gekkonidae, *Phelsuma madagascariensis grandis*) in the Masoala rainforest exhibit, Zurich Zoo. *Ecological Research*, 24(2), pp.345–353.
- Wiltling, A., Christiansen, P., Kitchener, A.C., Kemp, Y.J.M., Ambu, L. & Fickel, J., 2011. Geographical variation in and evolutionary history of the Sunda clouded leopard (*Neofelis diardi*) (Mammalia: Carnivora: Felidae) with the description of a new subspecies from Borneo. *Molecular Phylogenetics and Evolution*, 58(2), pp.317–28.
- Wong, W.M., Leader-Williams, N. & Linkie, M., 2013. Quantifying changes in sun bear distribution and their forest habitat in Sumatra. *Animal Conservation*, 16(2), pp.216–223.
- Yokoyama, Y., Lambeck, K. & Deckker, P. De, 2000. Timing of the Last Glacial Maximum from observed sea-level minima. *Nature*, 406(August), pp.1998–2001.
- Zhan, X., Zheng, X., Bruford, M.W., Wei, F. & Tao, Y., 2010. A new method for quantifying genotyping errors for noninvasive genetic studies. *Conservation Genetics*, 11(4), pp.1567–1571.
- Zhan, X.J., Zhang, Z.J., Wu, H., Goossens, B., Li, M., Jiang, S.W., Bruford, M.W. & Wei, F.W., 2007. Molecular analysis of dispersal in giant pandas. *Molecular Ecology*, 16(18), pp.3792–800.

Chapter 2: The natural history of banteng (*Bos javanicus*)

2.1 Abstract

The banteng (*Bos javanicus*) has been recognised by the scientific community for over 250 years. There are three subspecies, the Javan banteng, Burma banteng and the Bornean banteng, which have been recognised for over 100 years. The Bornean banteng (*Bos javanicus lowi*) is the rarest subspecies and also the least known. There is limited information available on the ecology of all three subspecies of banteng, and the few descriptions of their behaviour are located in rare books, in foreign languages, or in reports that are difficult to acquire. Furthermore, observations of their presence, use of habitat and records of banteng artefacts often go unrecorded.

This chapter aimed to provide the first compilation on the natural history of all banteng species across their range, including information on taxonomy, morphology, ecology and behaviour. I identified confusion in the taxonomic description of the Bornean banteng which was incorrectly listed as the Javan banteng on the International Union for Conservation of Nature and Natural Resources (IUCN) Red List of Threatened Species. I confirmed the decline in banteng in all countries, particularly in Borneo where the banteng is extinct in Brunei and most likely in Sarawak. In Sabah, I confirm the extinction of herds in the Dent Peninsular and illustrate the unknown status of [historic] herds identified in the 1980s.

This chapter is an extensive compilation of old and new information on the natural history of all three banteng subspecies. New and extensive information on the Bornean banteng, helped identify gaps in knowledge which are essential for conservation and management of Bornean banteng in Sabah. This information underpins the subsequent chapters.

This chapter (yellow comment on p.32 is irremovable) was published in a book detailing the ecology, evolution and behaviour of wild cattle throughout the world, and has also been used to update the IUCN Red List banteng species account, which is currently in review.

Melletti, M and J Burton, ed. 2014. *Ecology, Evolution and Behaviour of Wild Cattle: Implications for Conservation*. Cambridge: Cambridge University Press.

Gardner, P., Hedges, S., Pudyatmoko, S., Gray, T., Timmins, R., Hedges, S., Steinmetz, R., Pattanavibool, A., Burton, J., Duckworth, W. 2008. "*Bos javanicus*". In: IUCN Red List of threatened Species". In Review. www.iucnredlist.org/details/biblio/2888/0.

2.2 The natural history of banteng (*Bos javanicus*)

Part III

Species accounts

Chapter

13

Banteng *Bos javanicus* d'Alton, 1823

Penny C. Gardner, Satyawati Pudyatmoko, Naris Bhumpakphan, Marnoch Yindee, Datuk Laurentius N. Ambu and Benoit Goossens

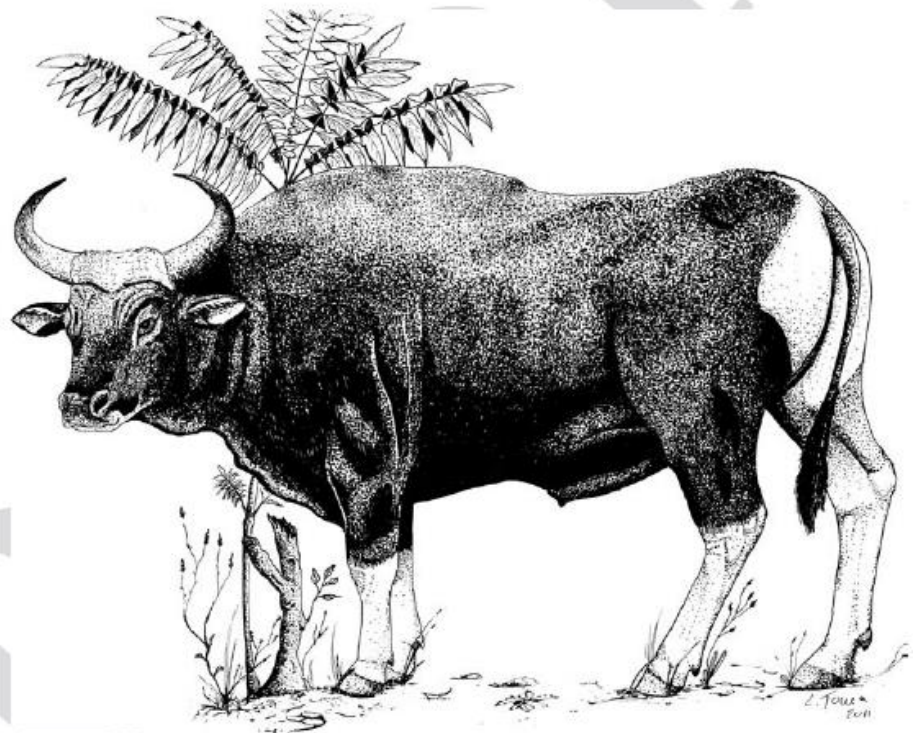

Names

Genus: *Bos* Linnaeus, 1758

Species: Banteng *Bos javanicus* d'Alton, 1823

Subspecies: Mainland banteng *Bos javanicus birmanicus* Lydekker, 1898. Java banteng *Bos javanicus javanicus* d'Alton, 1823. Bornean banteng *Bos javanicus lowi* Lydekker, 1912

Names in other languages: French: Banteng; German: Banteng; Spanish: Banteng; Italian: Banteng.

Other names: Malaysian (Sabah): Tembadau, Banting, Sapi hutan; Thai: Wau daeng วัวแดง; Laotian: Ngua Pha; Myanmar: Tsiane

Taxonomy

There is some evidence that suggests that the banteng is not a monophyletic species (see Hassanin & Ropiquet 2006); however, phylogenetic studies of this species are few and continue to be confounded by hybridization, small sample sizes (Nijman *et al.* 2003) and the inability to obtain tissue samples from all subspecies. Grzimek (1987) did not accept the separation of banteng into three subspecies as valid. He argued that interbreeding of small populations of wild banteng with domestic or feral cattle still occurred continuously. This suggestion was supported by Corbert & Hill (1992), who also did not recognize the existence of banteng subspecies. Timmins *et al.* (2008) proposed that *Bos javanicus lowi* should be included into *Bos javanicus javanicus*, yet no molecular studies have investigated the phylogeny of *B. j. lowi* due to the difficulty of obtaining tissue samples from wild individuals. Timmins *et al.* (2008) also proposed *Bos javanicus javanicus* and *Bos javanicus birmanicus* should be tentatively accepted as different subspecies. It is essential to clarify the genetic description of all subspecies through morphometric and molecular analysis prior to a merger of subspecies. For instance, four haplotypes from six faecal samples of banteng in Thai forests similar to Cambodia's banteng have been reported (Manatchaiworakul *et al.* 2011). However, these first analyses require further investigations to better understand the relationships between different banteng populations.

Until the beginning of the Quaternary, Java Island was still isolated from the Asian mainland, indicated by animals which were common dwellers of the island. The fossils found from this period demonstrate that the oldest faunal composition in Java is estimated as from 2–1. Ma (van den Berg *et al.* 2001), while the oldest fossils of early banteng (*Bibos palaesondaicus*) were discovered in Trinil HK (from 0.9 Ma to late Pleistocene) in East Java. During this period, the main habitat type in Java was open woodland. In East Java, early Banteng fossils were found in the younger stages of the fauna unit in Kedung Brubus (0.8–0.7 Ma), and in Ngandong in the late Pleistocene in Java. During the period of Kedung Brubus and Ngandong fauna unit, the environment was still dominated by open woodland, but in the next stage of fauna unit succession, namely Punung fauna unit (125–60 ka), the environment changed into moister forest. Fossils of early banteng were not found in this period, which might be due to acidic soils that decomposed banteng bones. The extinction of species might be due to dramatic climatic change. This finding suggests that early banteng were more adapted to open woodland than to rainforest (van den Berg *et al.* 2001). The oldest fossils of modern banteng (*Bos javanicus*) were found in Holocene caves in Sampung, Gua Jimbe and possibly Wajak, in East Java. These fossils were dated to approximately 10–6 ka (Whitten *et al.* 1996; van den Berg *et al.* 2001).

Subspecies and distribution

The species (*Bos javanicus*) is generally recognized as three distinct subspecies, mainly based on pronounced differences in phenotype appearance and colour (Halder 1976; Byers *et al.*

1995): *Bos javanicus birmanicus* in Myanmar, Thailand, Laos, Vietnam and Cambodia; *B. j. javanicus* in Java and Bali; and *B. j. lowi* in Borneo (Tun Yin 1967; Lekagul & McNeely 1988; Hassanin & Ropiquet 2006; Timmins *et al.* 2008). In general, the body size of *B. j. javanicus* in Java is larger than *B. j. birmanicus* in mainland Southeast Asia; *B. j. lowi* in Borneo is the smallest (Hoogerwerf 1970).

In the past, mainland banteng were found in larger distribution ranges than the other subspecies. Nowadays, mainland banteng are known to have disappeared from Bangladesh, India and South Malaysia (Medway 1969; Francis 2008). The worldwide distribution of banteng is represented in Plate 5.

Present distribution (mainland)

In Thailand, banteng can be found in 21 reserves within ten forest complexes. There are only four populations present in Huai Kha Khaeng Wildlife Sanctuary and Khaeng Krachan National Park in the west, and in Thong Pha Phum National Park and Khao Ang Ruenai Wildlife Sanctuary in the southeast part of Thailand (Bhumpakphan & McShea 2011).

In Myanmar, banteng were found in Piduung Wildlife Sanctuary (Tun Yin 1967). The species still occurs in scattered reserves in Indang forest in the north of the country (dry deciduous dipterocarp forest).

In Vietnam only five disconnected populations (estimated population 74–103 individuals) still exist. Herds in Vietnam are found in Yok Don National Park (30–40 individuals) and the Ea So Nature Reserve (23–31 individuals; Pedrono *et al.* 2009).

In Laos banteng were reported to be close to extinction, but recently herds have been observed roaming at the Phu Foi Lom mountainous area along the border of Thailand, and in both Buntharik–Yod Mon Wildlife Sanctuary and Dong Khanthung Proposed National Biodiversity Conservation Area.

In Cambodia banteng still persist in the dry forest on the northern plain of northern Cambodia along the border with Thailand. Banteng have also been reported in the northeastern plain to the east in Yok Don National Park of Vietnam.

Historical distribution (Borneo)

The historic distribution of banteng included Sarawak and Sabah (Malaysian Borneo) and Kalimantan (Indonesian Borneo). It is widely accepted that banteng previously occurred within Brunei and this has been noted many times (see Payne *et al.* 1985; National Research Council 2002; Timmins *et al.* 2008); however, no firsthand accounts of banteng encounters were found in any published book, peer-reviewed journal article or using an online search engine. Furthermore, it was suggested by Pedrono *et al.* (2009) that the banteng in Brunei were in fact *B. j. birmanicus* and not *B. j. lowi*; there is, however, no evidence to support this theory. With the exception of Sabah, no information is available on the historic distribution of banteng within Sarawak or Kalimantan. The distribution of banteng in Sabah and their population sizes were first estimated in 1982 (Davies & Payne 1982) using

Part III: Species accounts

community-based discussions. Populations of banteng were characterized according to seven categories – definitely present (post-1978); unknown (post-1978); pre-1978 records; present but rare or abundance unknown; present with intermediate abundance; present and common; and possible cattle hybrids – and mapped using a grid of 10^2 miles (Davies & Payne 1982). The total population size of banteng (not including possible hybrids) in Sabah was estimated to be between 300 and 550 in 1982 (Davies & Payne 1982). At the time of the survey the road infrastructure of Sabah was limited and remote forest access was severely restricted; this probably impeded data collection in more remote areas. After 1982 widespread timber production and logging activity increased the access to forested areas and their interior and, as a consequence, the conversion of secondary forest to vast monoculture plantations accelerated. This, together with human population expansion and encroachment of forest habitat, has probably exterminated some banteng populations identified by Davies & Payne (1982).

Present distribution (Borneo)

The present-day distribution of banteng includes Sabah, (possibly) Sarawak and Kalimantan. In eastern Sabah, surveys of banteng were conducted by P. Gardner (unpublished) in Tabin Wildlife Reserve and Malua Forest Reserve in 2011–2013 using camera traps and sign detection. From the photographic captures obtained from the camera traps, multiple herds were identified in both locations and were recognized to be breeding successfully. Supplementary information on banteng in other forest reserves was obtained from other researchers using camera traps to study a range of species since 2008, and from the Sabah Wildlife Department, the Sabah Forestry Department and Malua BioBank. Minimum population sizes were estimated from photographs of identifiable individuals, from presence of signs (tracks and dung) in areas where no photographs were obtained and from direct sightings. Minimum population size estimates were >52 individuals in Tabin Wildlife Reserve and >35 individuals in Malua Forest Reserve (Table 13.1). An estimated 100 individuals were thought to be present in Kulamba Forest Reserve (Timmins *et al.* 2008); however, it is unclear how this figure was obtained. The current presence of banteng was confirmed in a number of historic locations (also identified in 1982 by Davies & Payne (1982)), including Segaliud and Tangkulap Forest Reserves. However, current data are too deficient to estimate present-day minimum population sizes. The current distribution of banteng in Sabah (Figure 13.1) is largely confined to the east and central districts; surveys of remnant populations in the north, south and west are yet to be conducted. One historic population in the Dent Peninsular of the Lahad Datu district was confirmed as extinct in 2012 due to complete loss of habitat, which occurred in the past three decades. Confirmation of the status of the remaining historic populations is required in order to establish the complete current distribution

of banteng in Sabah. On the Sarawak/Sabah border and the northeast Sarawak/north Kalimantan border small populations of banteng may still persist (Belding Gimán, personal communication 2012). In Kalimantan six banteng populations were identified by Pudyatmoko *et al.* (2012) using information collected from various sources during 2003 to 2009; the collective minimum population size estimate was approximately 106 in 2010; however, this information was based on guesses or counts using unsystematic techniques. The present distribution of banteng in Kalimantan extends from East Kalimantan to Central Kalimantan and includes protected national parks and unprotected land, including plantations.

Descriptive notes

Body measurements: **Shoulder height:** 120–190 cm; **Head and body length:** 245–383 cm; **Tail length:** 60 cm; **Body mass:** 400–900 kg. Dental formula: I 0/3, C 0/1, P 3/3, M 3/3 ($\times 2$) = 32 (Wilson & Mittermeier 2011).

The three subspecies share many morphological characteristics, including a large white patch on the buttocks and white stockings on their lower legs (Lydekker 1913). The whitish or pale brown spot above the eye and the white band around the muzzle are not present in Bornean banteng (P. Gardner, personal observation).

The National Research Council (2002) stated that banteng in Borneo are the smallest of all three subspecies, but no guideline weights of Bornean banteng were provided to substantiate that claim. The weight of ‘average-sized bulls’ from Java and Burma was 635 kg and 825 kg for large bulls, while cows weighed 400 kg (National Research Council 2002). The estimated weight of a Bali cattle (domesticated form of banteng) bullock that was approximately three years of age from Lok Kawi Wildlife Park (Kota Kinabalu, Sabah) was 400 kg, recorded in 2012 (Sen Nathan, personal communication). The shoulder height of the same Bali cattle bullock was measured at 114 cm. The shoulder height of banteng in Java was estimated to be 160–190 cm for bulls and 140 cm for cows (National Research Council 2002), but the ages of the individuals were unknown.

Banteng are sexually dimorphic in both pelage and body shape. Mainland bulls vary from chestnut to rusty brown, while females and juveniles are chestnut. In Cambodia, 20% of the bulls are blackish, but in the Southern Peninsula of Thailand most bulls are black. On average the head measures 60 cm (Hoogerwerf 1970). The horn length varies from 25 cm to 39 cm from tip to tip and the horn girth about 16 cm to 20 cm in Java banteng for old cows (Hoogerwerf 1970).

Male calves are born with a light pelage and white buttocks (Figures 13.2–13.3). During the first month the male Bornean banteng develops white stockings and the first signs of poles or horns (P. Gardner, personal observation). After two months of age their pelage shows the first signs of darkening, beginning with the undercarriage, along the spine, the tip of the tail and facial features (P. Gardner, personal observation). Pelage

Table 13.1 Collated information on the status, location and size of remnant herds of banteng in Sabah (Borneo) documented over the past five years (2009–2013) by various sources.

Location	Population status	Minimum population size estimate	Data type	Source of information and year
Sabah (Malaysia), Borneo				
Tabin Wildlife Reserve	Present and breeding	>52	Camera trap photographs, signs and direct observations Camera trap photographs, signs and dung sample Direct observations and signs Camera trap photographs	Gardner (unpublished), 2013 IZW/BORA/SWD/SFD (unpublished), 2012 Sabah Wildlife Department (unpublished), 2011 Hearn & Ross (unpublished), 2009
Dent Peninsula (Lahad Datu district)	Extinct	Extinct	Forest converted to oil palm plantation	Gardner (unpublished), 2013
Malua Forest Reserve	Present and breeding	>35	Camera trap photographs and signs Direct observations and signs Camera trap photographs	Gardner (unpublished), 2013 Sabah Forestry Department/Malua BioBank (unpublished), 2011–2012 Hearn & Ross (unpublished), 2010
Tangkulap Forest Reserve	Present but breeding status unknown	Unknown	Camera trap photographs	Wilting (unpublished), 2009
Segaliud Forest Reserve	Present and breeding	Unknown	Camera trap photographs	Wilting (unpublished), 2010
Danum Valley Conservation Area	Present but breeding status unknown	Unknown	Personal communication	Sabah Forestry Department/Malua BioBank (unpublished), 2013
Kulamba Forest Reserve	Present but breeding status unknown	100	Unknown Direct observation	(Timmins <i>et al.</i> 2008) (Sabah Wildlife Department, personal communication)
Deramakot Forest Reserve	Present and breeding but possible hybrid	100	Unknown Camera trap photographs	(Timmins <i>et al.</i> 2008) (Samejima <i>et al.</i> 2012)
Kinabatangan Wildlife Sanctuary (Sukau)	Unknown	Unknown	Community surveys	(Davies & Payne 1982)
Tongod District	Unknown	Unknown	Community surveys	(Davies & Payne 1982)
Kudat District	Unknown	Unknown	Community surveys	(Davies & Payne 1982)
Kudat Marudu Bay Forest Reserve	Unknown	Unknown	Community surveys	(Davies & Payne 1982)
Pitas district	Unknown	Unknown	Community surveys	(Davies & Payne 1982)
Pitas district	Unknown	Unknown	Community surveys	(Davies & Payne 1982)
Sugut district	Unknown	Unknown	Community surveys	(Davies & Payne 1982)
Kpg. Mansud (Kota Klias District, Interior Division)	Unknown	Unknown	Community surveys	(Davies & Payne 1982)
Sigapon (Keningau district, Interior Division)	Unknown	Unknown	Community surveys	(Davies & Payne 1982)
Sipitang Forest Reserve (Interior Division)	Unknown	Unknown	Community surveys	(Davies & Payne 1982)
Nabawan (Interior Division)	Unknown	Unknown	Community surveys	(Davies & Payne 1982)
Tenom (Interior Division)	Unknown	Unknown	Community surveys	(Davies & Payne 1982)

Part III: Species accounts

Table 13.1 (cont.)

Location	Population status	Minimum population size estimate	Data type	Source of information and year
Maliau Basin Conservation Area	Present and breeding	>10	Camera trap photographs Direct observation	Brodie (unpublished), 2010 Amos (personal communication), 2011 Gardner (unpublished), 2013
Semporna District	Unknown	Unknown	Community surveys	(Davies & Payne 1982)
Ulu Kalumpang Forest Reserve (Kunak District)	Unknown	Unknown	Community surveys	(Davies & Payne 1982)
Tawau Hills National Park	Unknown	Unknown	Community surveys	(Davies & Payne 1982)
Tinagat Forest Reserve (Tawau District)	Unknown	Unknown	Community surveys	(Davies & Payne 1982)
Kalimantan (Indonesia), Borneo				
Lamandau Regency	Unknown	Unknown	Population distributed in some villages	(Pudyatmoko <i>et al.</i> 2012)
Kutai National Park	Unknown	1989: 48 individuals 1993: 40 individuals 2002: 34 individuals 2003: 34 individuals	Unknown	(Pudyatmoko <i>et al.</i> 2012)
KayanMentarang National Park	Unknown	2008: 72 individuals	Unknown	(Pudyatmoko <i>et al.</i> 2012)
Nunukan Regency	Unknown	No quantitative data	Unknown	(Pudyatmoko <i>et al.</i> 2012)
Malinau Regency	Unknown	No quantitative data	Unknown	(Pudyatmoko <i>et al.</i> 2012)
Berau Regency	Unknown	No quantitative data	Unknown	(Pudyatmoko <i>et al.</i> 2012)

progressively darkens, and poles rapidly develop after two months; growth (in length) is estimated (approximately) to be one inch per month until at least nine months of age (P. Gardner, personal observation). At approximately 9–10 months coat colour is dark brown and horns are approximately five inches long and noticeably wider in spread, with tips pointing outward (P. Gardner, personal observation), and at approximately two years of age males have changed coat colour to black and poles are ‘crescent shaped’ (National Research Council 2002). Over two years of age banteng bulls develop heavier forequarters and a small dewlap, the coat turns black, with a black tail and white stockings and white buttocks (Figure 13.4). The poles continue to expand in dimension until approximately ten years of age and change from all black to black with brown at the base (P. Gardner, personal observation). The shape of the poles for a mature bull can range from broad, symmetrical and slightly crescent-shaped to broad, symmetrical and tightly crescent-shaped (P. Gardner, personal observation). Pole spread of bulls was estimated to be approximately 60–75 cm (National Research

Council 2002); however, it is not clear which subspecies this measurement relates to.

Like males, female calves are also born with a light tan coat and white buttocks, and are identical in appearance to male calves (P. Gardner, personal observation). They develop poles and change pelage colour at a slower rate than males; at approximately 2–2.5 months old female calves develop white stockings and the first sign of poles (P. Gardner, personal observation). After this time their coat colour progressively darkens to brown with a dark undercarriage, black tip of the tail and slightly darker facial features, and they may or may not develop a dark-brown/black streak along the spine. At six months of age the poles of female calves are approximately 1–2 inches long and, at one year of age, poles are approximately six inches long and straight (P. Gardner, personal observation). By two years of age the poles are noticeably crescent-shaped, and unique features such as light forehead patches, imperfections on the poles and scars on the neck resulting from fly bites become more apparent (P. Gardner, personal observation).

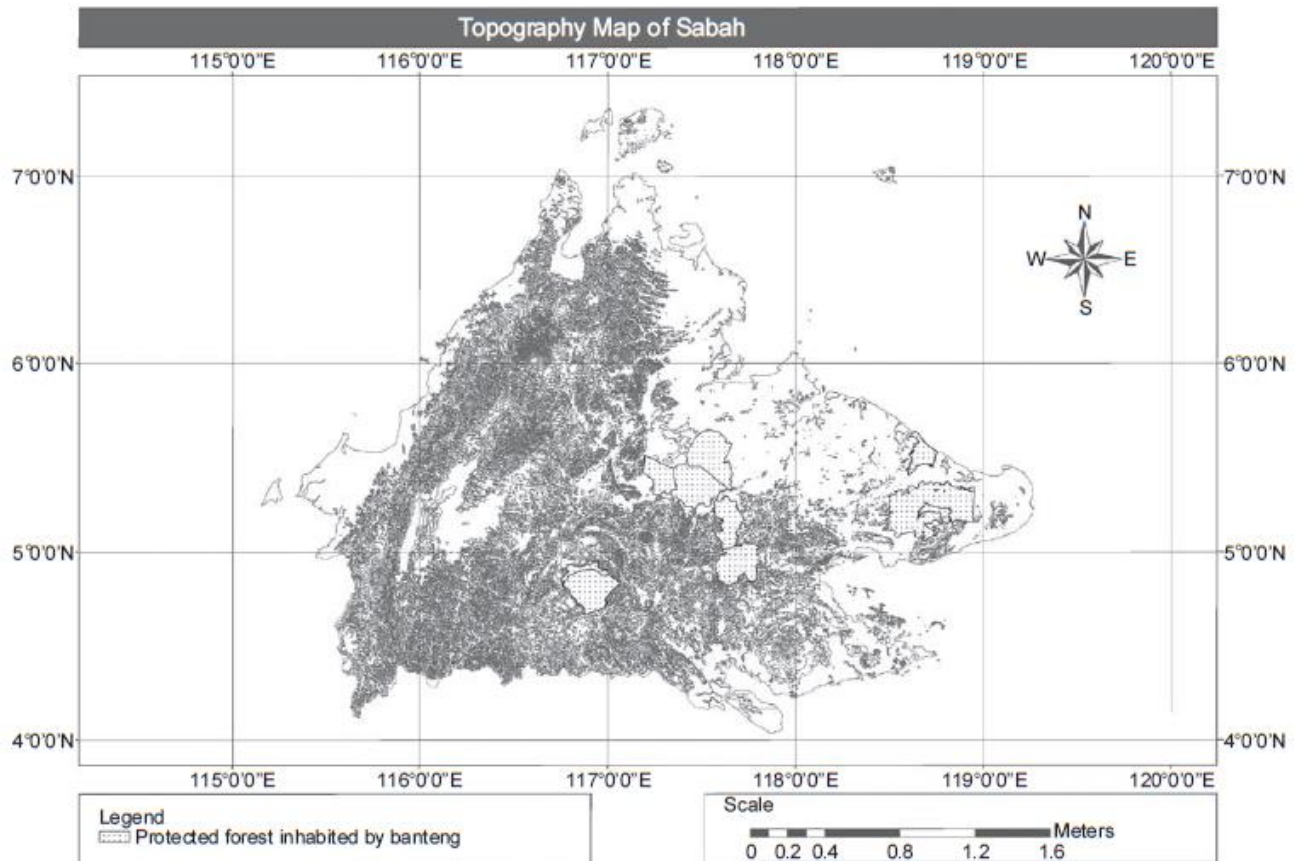

Figure 13.1 Map of Sabah (Malaysia, Borneo) depicting the protected forest areas inhabited by banteng during the past five years (2009–2013, Penny C. Gardner).



Figure 13.2 A mixed herd of banteng in Alas Purwo National Park (Java) consisting of bulls, cows, subadults and juveniles (photo by Pudyatmoko). A black and white version of this figure will appear in some formats. For the colour version, please refer to the plate section.

Part III: Species accounts



Figure 13.3 The banteng form herds with several clans (cows with calf and juvenile in Thailand); herds range from 2 to 30 individuals. Each herd is usually led by an old cow. A black and white version of this figure will appear in some formats. For the colour version, please refer to the plate section.



Figure 13.4 Mature dominant bull in Malua Forest Reserve/Malua BioBank (Borneo), captured on camera trap in 2011 (© Danau Girang Field Centre/Sabah Wildlife Department using Reconyx PC800 HyperFire Professional Semi-Covert IR camera trap). A black and white version of this figure will appear in some formats. For the colour version, please refer to the plate section.

The pelage colour of mature cows ranges from very light brown to dark brown with characteristic white rump and stockings (P. Gardner, personal observation). The poles of cows darken with age from brown to dark brown or black, with a shape that ranges from symmetrical and slightly crescent-shaped, to non-symmetrical, long and slightly inverted, and broken (P. Gardner, personal observation).

Habitat

Mainland banteng mostly inhabit dry forests in the lowland areas in Thailand (Nakhasathien *et al.* 1987; Prayurasithi 1987). The banteng population in Huai Kha Khaeng Wildlife Sanctuary, western Thailand, strictly uses the lowland valleys of 160–600 m elevation. The species at Xe Pian Biodiversity



Figure 13.5 Tropical lowland dipterocarp forest is the principal habitat type of banteng in Sabah, Borneo (photo by Penny C. Gardner). A black and white version of this figure will appear in some formats. For the colour version, please refer to the plate section.

Conservation Area in Laos use similar habitats (Steinmetz 2004). However, banteng may show some seasonal difference in habitat use.

Until the beginning of the nineteenth century banteng were still present in almost all areas of Java Island (Hoogerwerf 1970). The altitudinal range of this subspecies included coastal forest, lowland and highland forest up to 2000 m above sea level. The German botanist Junghuhn reported in the eighteenth century that banteng preferred to live in high forests in west Java. Interestingly, he had never seen banteng eastward of Mount Tengger and Mount Semeru. Hence, he never reported the occurrence of banteng in the current main habitats in Java, namely in Meru Betiri, Baluran and Alas Purwo National Park. Due to rapid human population growth and intensive development in Java, large forest areas were converted for agricultural purposes and buildings. Habitat loss and fragmentation were the main causes of population decrease and range shrinking of banteng in Java.

In Sabah (Borneo) the predominant habitat type inhabited by banteng is tropical lowland dipterocarp forest (Timmins *et al.* 2008; P. Gardner, unpublished), which occurs <300 m in elevation and comprises numerous species of *Dipterocarpacea*, including *Dipterocarpus*, *Shorea* and *Dryobalanops aromatica* (Whitemore 1990). Secondary tropical lowland dipterocarp forest that is regenerating is characterized by dense vegetation at ground level and includes species such as wild ginger, rattan and vines and lianas, which provide favourable refuge for banteng (Figure 13.5). Banteng are also found in mixed hill dipterocarp forest (P. Gardner, personal observation), seasonal freshwater swamp forest and beach forest (Davies & Payne 1982; Timmins *et al.* 2008). Banteng have not been observed in mangrove or Nipah forests.

Seasonal variation in habitat use was only observed in one instance in seasonal freshwater swamp forest in Eastern Sabah;

local villagers often observed banteng foraging in a secluded open grassland swamp during the summer months/dry season (April–September) but never during the wet/monsoon season (October–March). During the monsoon season the main river, inhabited by saltwater crocodiles, and smaller tributaries flooded the surrounding freshwater swamp forest. The combination of physical obstruction by the sheer volume of water and the quantity of sediment within the water probably decreased the conspicuousness of crocodiles. This, in turn, may have reduced site selection and habitat favourability during the wetter months.

Movements and home range

A study on banteng home range was carried out at Huai Kha Khaeng wildlife sanctuary (Thailand) by Prayurasithi (1997). He reported that herds utilized a home range of 20.0–44.0 km² in the dry season and 30.0–44.8 km² in the wet season. Individuals released from captivity formed a single herd and used a home range larger than 8 km².

The pattern of banteng movement was different from one site to another in Java. Alikodra & Sastradipraja (1983) reported that the movement of banteng in Ujung Kulon National Park was not regulated by seasons. Herds of banteng usually moved in the same pattern and used the same area regardless of the season. Regular movement in a relatively small area resulted from a small difference in resource availability in dry and wet seasons. A differential movement pattern was observed in Baluran National Park, Java (Halder 1976). Banteng were strongly but indirectly influenced by season (Halder 1976), and directly by the distribution of water, food and predators, as well as disturbance caused by human activities (Pudyatmoko 2005). Observations in Baluran National Park showed that

Part III: Species accounts

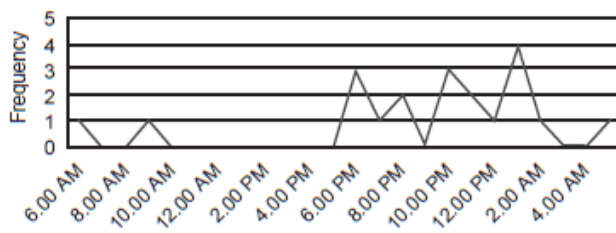

Figure 13.6 Diary of bantengs' activity recorded from camera trapping in Khao Ang Runai Wildlife Sanctuary, Thailand (Bhumpakphan & Yindee, unpublished).

in the dry season most individuals concentrate in and around Bekol, where food and water are more abundant. In the rainy season, when food and water are available everywhere, the subspecies move throughout the whole area. Banteng require a mosaic habitat within their home range. An ideal habitat should be composed by large secondary forest and grazing area with enough fresh water.

No estimates on home range size or daily travel distances are available for Borneo. Photographic recaptures of recognizable mature bulls in 2009–2013 in Malua Forest Reserve and Tabin Wildlife Reserve indicated that they travelled at least a distance of 10 km and 23 km, respectively (P. Gardner, unpublished). Attempts to capture and collar wild banteng are currently under way in Sabah by Danau Girang Field Centre and the Sabah Wildlife Department; the purpose of this is to document banteng home range size, movement patterns in relation to forest use and habitat disturbance and target areas for conservation management.

Activity patterns

In undisturbed conditions, the banteng's daily activity has a more or less fixed rhythm (Figure 13.6). During the daytime, individuals alternate active and resting periods of 2–3 hours each. Active periods predominantly involve feeding, drinking and social interactions at night. If the pressure by predators and poachers is strong they will shift their activity during the night. Halder (1976) reported that in Ujung Kulon National Park (Java) individuals were active in open areas both at night and during the day. However, he found that banteng in Baluran National Park (Java) were only active in the grassland during the night. This observation was not consistent with the later monitoring conducted by Pudyatmoko (2005). In Baluran National Park, several groups graze in the open area in the early morning until 08:00, and occasionally until 10:00. Banteng then enter the forest to avoid the hot temperatures in the open area. They appear again in the afternoon at about 15:00, and stay there until the night. In Alas Purwo National Park they behave in the same manner as those in Baluran National Park. The most active social activities take place during the morning and afternoon. In Ujung Kulon National Park, during the day individuals spend two hours grazing followed by the same amount of resting period (Halder 1976).

Initial observations of banteng in Borneo by P. Gardner (unpublished) in 2011 and 2012 indicated activity peaked at dawn and during the early morning hours of 05:00–07:00, when banteng emerged from the forest to forage and socialize. No sexual segregation of activity patterns was found. Activity was found to decrease in the later hours of the morning (>09:00) until early afternoon (15:00), when banteng were observed resting and ruminating. In the early evening and at dusk (17:00–18:00) a second peak in banteng activity occurred during which they were observed foraging and socializing. Banteng activity decreased during the night, particularly around 20:00–21:00 and in the early morning at 03:00–04:00; the reasons for this were unknown. No instances of wallowing were observed, despite the monitoring of numerous mud wallows for extended periods of time using camera traps. Furthermore, no evidence of banteng were found at the two mud volcanoes in Tabin Wildlife Reserve.

Feeding ecology

Banteng can be classified as a mix feeder that frequently forages in open grasslands, dry forest and on the edges of evergreen forests. The species sometimes also feed on bamboos, fruits and leaves. In Huai Kha Khaeng (Thailand) they utilize up to 150 different plant species (Prayurasithi 1997; Bhumpakphan & McShea 2011). Banteng are observed at salt licks and waterholes regularly (Tun Yin 1967; Lekagul & McNeely 1988; Prayurasithi 1997).

Faecal analysis and direct observations conducted in Baluran and Alas Purwo National Park (Java) in Ujung Kulon (Hoogerwerf 1970; Halder 1976; Pudyatmoko 2005; Pairah 2007) discovered that the diet consists of grass, tree leaves, herbs, shrubs, twigs and fruit, as well as bark of certain tree species. Table 13.2 lists the main grasses, herb/bush and tree species recorded in Baluran National Park, Java (Halder 1976; Pudyatmoko 2005).

Preliminary observations suggest that *B. j. lowi* in Borneo forage on grasses, herbs, soft vines and wild fruits such as guava (Myrtaceae) (P. Gardner, personal observation).

Within tropical lowland dipterocarp forest in Sabah (Borneo) the preferred foraging areas (characterized by heavy use) were found to be interior openings, because they contained an abundance of suitable grassy forage and were less disturbed by human activity. Foraging behaviour was found to vary with forest structure. Observations of a forest logged in 2009 found banteng repeatedly foraged along internal abandoned logging roads and in interior openings, and banteng were rarely sighted and infrequently detected (by dung deposits) along the main access road (P. Gardner, personal observation). In comparison, observations of an older logged forest which had regenerated over 25 years found that banteng repeatedly foraged along the main access roads (detected by dung and tracks), open river banks and occasional interior openings (P. Gardner, personal observation). It was thought that the early stages of regeneration provided temporary grass-

Table 13.2 Main grass, herb/bush and tree species recorded in Baluran National Park, Java

No.	Grass species	Herb/bush species	Tree species
1	<i>Brachiaria reptans</i>	<i>Aneilema pudiflorum</i>	<i>Sesbania sesbans</i>
2	<i>Sclerachne punctata</i>	<i>Plumbago zeylanica</i>	<i>Tamarindus indica</i>
3	<i>Themeda arguens</i>	<i>Abutilon crispum</i>	<i>Acacia nilotica</i>
4	<i>Heteropogon contortus</i>	<i>Benincasa hispida</i>	<i>Schleicera oleosa</i>
5	<i>Themeda triandra</i>	<i>Portula oleraceae</i>	<i>Grewia eriocarpa</i>
6	<i>Sclerachne punctata</i>	<i>Bidens pilosa</i>	<i>Thespesia lampas</i>
7	<i>Echinochloa colonum</i>	<i>Aeschynomene indica</i>	<i>Phyllanthus emblica</i>
8	<i>Dichantium caricosum</i>	<i>Barleria prionitis</i>	<i>Corypha utan</i>
9	<i>Brachiaria subquadrifera</i>	<i>Ipomoea obscura</i>	<i>Hibiscus tiliaceus</i>
10	<i>Eulalia amaura</i>	<i>Crotalaria mucronata</i>	<i>Azadirachta indica</i>

Source: Halder 1976; Pudyatmoko 2005.

rich interior foraging sites, which negated the need to forage along the forest edge. Post-logging regeneration provides a temporary abundance of pioneer vegetation, including scrub and grasses which appear to benefit the bantengs' body condition and their ability to breed successfully. The effects of logging activity, however, are likely to be counter-intuitive to the long-term survival of banteng as the act of deforestation, increased human presence and heavy machinery will elevate stress levels that will not only reduce banteng breeding activity, but may even cause mortality. Furthermore, it was not uncommon for those people working at logging camps to hunt banteng for meat.

Reproduction and growth

Banteng cows usually produce a single calf that is weaned at around 6–10 months. Sexual maturity occurs at 2–3 years of age in females and 5–6 years of age in males. Gestation period in *B. j. birmanicus* in Malaya was 285–300 days and oestrus recurs 6–8 weeks after parturition (Medway 1983).

In general, male Javan banteng grow faster and larger than females. The maximum body size of a female will be reached at three or four years, but the bull between five and six years (Choquenot 1993). Sex ratio at birth is 1:1 (National Research Council 1983). However, it might vary from site to site

(Hoogerwerf 1970; Choquenot 1993). In some sites, sex ratio of adult animals can change if a specific pressure operates on the population. For example, continuous observation in Baluran National Park (Java) from 1999 to 2005 showed a clear decrease of the female population. Predation by dholes was suspected to be the determining factor (Pudyatmoko 2005). Females were sexually mature at the age of two to four years, and producing a calf at three to five years. Only about 33% of males of 3.5 years had reached maturity, but bulls of more than 4.5 years were all mature. The fecundity of females peaked at 6–7 years then declined among older cows (Choquenot 1993). The proportion of pregnant cows in the Java population was more than 50% (National Research Council 1983; Hedges & Tyson 1996). In the wild, the mortality rate of immature animals was very high. In Cobourg Peninsula, Northern Australia about 26% of calves died in the first six months (Choquenot 1993). However, in captivity bulls can reach 20 years or more (Halder 1976). In the wild, cows can live until 20 years (Hoogerwerf 1970).

In Borneo cows are able to reproduce at three years of age, and young bulls begin to spend periods of time separate from the natal herd at three years of age, when they are also thought to become sexually active (P. Gardner, personal observation). Parturition did not appear to be seasonal in herds located in Tabin Wildlife Reserve and Malua Forest Reserve in Sabah (Borneo); young calves were observed throughout the year (P. Gardner, personal observation).

Behaviour

Social organization (mainland and Java banteng)

Banteng live in groups that can consist of many members, ranging from 2 to 30 individuals (Figures 13.2–13.3). Each herd is usually led by an old cow. Young bulls form a herd with two or three individuals. Adult bulls are solitary but enter a cow herd for mating (Tun Yin 1967; Lekagul & McNeely 1988).

Figure 13.2 shows a mixed herd consisting of adult cows and bulls, subadults and juveniles in Sadengan feeding ground in Alas Purwo National Park (Java). This photo (Figure 13.2) was taken during the early rainy season. Detailed observations of group structure and social behaviour of wild banteng were conducted in Baluran National Park; four types of herd were observed in this park: (1) solitary individuals, (2) small and stable herds, (3) small and temporary herds and (4) large groups which comprised several herds (Pudyatmoko 2005). Solitary animals were mostly old bulls, which were forced by younger bulls to leave the herd. Occasionally in the feeding ground in Baluran National Park an old bull tried to join a herd. It could feed with other members, but when the herd was leaving the feeding area the solitary bull separated from the group and moved in a different direction. A solitary cow was rarely observed. A stable herd was mostly composed of very young animals with their mothers. From regular observations

Part III: Species accounts

it can be concluded that most herds were not stable; banteng frequently changed their groups. A rather stable herd was a bachelor group that consisted of young bulls. The degree of sexual segregation between male and female groups was low. The reasons sexual segregation was absent was probably due to small population abundance and distribution of resources, the presence of predators and the combination of these factors (Pudyatmoko 2005). Up to 80% of the herds were mixed groups that consisted of one to ten animals. A large group composed of more than 50 individuals was very rare. An example of this kind of group was observed in the feeding ground in Baluran National Park, a large herd which consisted of five herds containing 35, 12, 14, 8 and 3 individuals. This large herd lasted only about an hour (Pudyatmoko 2005). An old cow generally is the leader in the mixed herd (Pudyatmoko 2005). She is the most alert individual while the others are grazing. She alerts the group if a potential danger is detected. In addition, this cow determines the direction of the herd's movement. The bulls have only a minor role as leader. The competition among bulls for cows was difficult to observe in wild banteng. Even in the rut season sparring between bulls was rarely seen. It might be that each individual already understands his position in the social hierarchy of the herd. A dominant bull shows his body and horn size in a lateral display. Actual fights were seen only rarely. When a bull approached a dominant male in the group then they started to push against each other with their heads. The fight lasted a very short time. The loser flees quickly. Usually, the fight is not dangerous for either bull (Pudyatmoko 2005).

Social organization (Bornean banteng)

Social organization is dynamic and herd compositions include solitary individuals, bachelor groups of mixed ages, cow and calf groups and mixed herds. Where mixed herds have been observed, a single bull appeared to maintain dominance by driving off other bulls and juvenile bulls in close proximity to the cows. On some occasions during feeding activity the cows and calves appeared to assert authority over particular mineral licks and the dominant bull displayed considerable tolerance by exhibiting gentle behaviour, particularly towards young calves. Play-fighting was regularly observed between younger bulls of the same age, but also between younger bulls and the dominant bull. At times the cows, calves and young males of the same herd visibly aggravated the dominant bull for no apparent reason.

During breeding and the early stages of a calf's life the dominant (assumed sire) bull maintains close proximity to his progeny and also drives off other bulls within the vicinity. A change in dominance of a small herd containing two calves, two cows, one heifer, one bullock and two bulls was observed in Malua Forest Reserve in 2011 by P. Gardner (personal observation); the mature dominant bull was observed fighting with the younger bull; the end result was the exclusion of the mature dominant bull. For up to five months following his

absence from the herd, the mature bull was observed visiting an open grassland site also visited by the herd, but was never again observed accompanying the herd. After this time the mature bull was never observed again and was presumed to have moved out of the area or died of natural causes.

Herd size (Bornean banteng)

Preliminary observations of banteng herd density in different canopy covers were obtained using camera trap photographs in secondary forest in 2011 and 2012. Camera traps established in continuous canopy cover captured photographs of herds with fewer than eight individuals, whereas camera traps in grassland with an open canopy captured herds of fewer than 18 individuals (P. Gardner, personal observation). Variation in herd size was attributed to two factors: (1) detection of all individuals under the canopy was imperfect due to understory vegetation and individuals walking behind the camera trap; and/or (2) herds of large numbers had to split into smaller groups under continuous canopy cover because understory vegetation was dense, but the large herds converged in open areas to socialize and forage (P. Gardner, personal observation).

Parasites and diseases

Banteng have been reported to carry disease and parasites just like other large herbivores, such as tuberculosis, brucellosis, salmonellosis, endo- and ectoparasites. However, banteng populations are exposed to the risk of disease outbreaks from domestic livestock around protected areas. Blackleg (*Clostridium chauvoii*) and mucosal disease have caused heavy losses in captive banteng in European zoos (National Research Council 1983).

The cause of poor physical condition of banteng cannot be explained merely based on malnutrition and unfavourable habitat condition. Veterinary examinations conducted on banteng in very poor condition in Ujung Kulon National Park (Java) found that these animals were infected by the parasites *Fasciola hepatica* and *F. gigantica*. For Bali cattle (the domesticated form) the most dangerous was Jembrana disease, which killed 10–60% of animals in certain localities. This disease was transmitted by cattle tick (National Research Council 1983). To avoid the transmission to wild individuals, direct contact between banteng and domestic cattle should be prevented.

Status in the wild

Worldwide status

The banteng is Endangered (IUCN 2013) in the whole geographical distribution. Small available habitat size, illegal poaching and competition with domestic livestock have negatively affected the banteng population in the last few decades. They have disappeared from many reserves in Thailand and from several countries. Therefore, management plans for both

in situ and *ex situ* conservation are required for the long-term survival of the species.

The feral population of banteng in the North Territory of Australia consists of about 6000 individuals and seems genetically similar to wild banteng. This population was founded from a small number of Bali cattle (domestic form of wild banteng; Wilson & Mittermeier 2011).

Mainland banteng

In situ and *ex situ* conservation

Meta-populations of banteng are found in many subpopulations throughout its historical range due to habitat fragmentation and habitat loss.

In 2005 the Zoological Organization of Thailand carried out banteng reintroduction with 13 captive-born individuals into Khao Khiew – Khao Chompu Wildlife Sanctuary in southeast Thailand. Over a four-year period the population increased to 34 individuals. They now form a single herd with a home range greater than 8 km². Salakphra Wildlife Sanctuary (WS) is now thought to be the main site for future reintroduction. The banteng recovery project is designed under the Management Plan for Salakphra WS in order to reintroduce captive mainland banteng from Khao Nampoo into this former banteng habitat site.

Java banteng

Up until 1970 there were 13 locations known as banteng habitat in Java. Currently, only four locations are inhabited by banteng (Pudyatmoko 2005). The nine extinct populations were previously located in: (1) Cikepuh-Cibanteng; (2) Leuweng Sancang; (3) Pangandaran; (4) Bojonglarang Jayanti; (5) Cimapag; (6) Cikamurang; (7) Kediri; (8) Malang; and (9) Blitar Cikepuh-Cibanteng and Leuweng Sancang Nature Reserves. All of these were previously considered as important habitat for banteng in Java, but the species has been extinct in these locations since 2003. According to historic records, the population size in Cikepuh-Cibanteng was estimated to be about 300 animals in 1970, and the population size in Leuweng Sancang was 200 animals in 1988. Another location with a relatively large population was Pangandaran Nature Reserve, which contained more than 100 banteng up until 1974. However, it was considered that individuals in Pangandaran were hybrids with cattle. Banteng were formerly found in teak plantations on the coast of Blitar, Kediri and Malang, but they are now most probably extinct. The same occurred in Bojonglarang-Jayanti, Cimapag and Cikamurang areas, where the species is locally extinct (Pudyatmoko 2005). The main causes of extinction in some places in Java were habitat degradation and poaching. It seems that there is a strong correlation between habitat size and extinction. All extinct banteng in Java inhabited an area of less than 10 000 ha. This trend should be better investigated for future conservation and management practices.

Currently, Java banteng are living in remnant and isolated habitats in four national parks: Ujung Kulon, Meru Betiri, Baluran and Alas Purwo. The biggest population of wild banteng occurs in Ujung Kulon National Park in a habitat of about 30 000 ha. Although the national park covers about 122 000 ha, not all areas are suitable or occupied by banteng. The highest numbers were 905 individuals recorded in 1997 (Pudyatmoko 2005). Because this park is the only part of the world with Javan rhino (*Rhinoceros sondaicus*), the highest priority of the park is the conservation of this species. Increasing numbers of banteng are considered a threat to Javan rhino, and some measures were planned to reduce the number of banteng in the park, including the capture and relocation of individuals to other areas, but these plans have not yet been carried out.

The second most important habitat for the banteng is Alas Purwo National Park. It covers an area of 43 420 ha, but not all is suitable habitat. In Alas Purwo National Park, a sharp decline in the population took place from 1992 to 1995. During this period the number of banteng decreased from 323 to 119 individuals. The cause of the population decline was unsustainable predation by dhole (Hedges & Tyson 1996). As the population of dhole declined, the population of banteng has been in the process of rapid recovery. This trend was shown by the continuously increasing number of banteng seen in Sadengan feeding ground from 2007 to 2011. Regular monitoring of the populations showed that the maximum number of individuals seen in a single observation was 21 animals in 2007, 56 in 2008, 61 in 2009, 94 in 2010 and 100 in 2011.

Contrary to this, the banteng population in Baluran National Park is decreasing at an alarming rate, indicated by a decreasing encounter rate of individuals in all areas within the national park. Regular observations showed that the number of banteng in Bekol feeding ground decreased from 101 animals in 2002 to 47 in 2003 and to zero in 2006 (Pudyatmoko 2005). However, in the same year regular surveys using concentration counts recorded 15 animals. The result of a survey in 2011 recorded 15 individuals as a minimum number. Currently, it is very difficult to see banteng at Bekol feeding ground or at waterholes. A combination of some factors such as illegal hunting, predation by dhole and degradation of habitat quality were the causes of decline (Pudyatmoko 2005).

The population size of banteng in Meru Betiri National Park was relatively stable. The number fluctuated between 125 to 150 animals. It seems that the future of the subspecies in this park is relatively secure. The management problem of banteng here is the movement of animals crossing the border of the national park and entering cacao and coffee plantations, where forage like young grass and leaves were more abundant. The conflicts between banteng and people arise because this subspecies eat cacao fruits and destroy the bark.

Outside the protected areas, banteng occupy teak, cacao and coffee plantations, especially in Banyuwangi District, east Java. In this area human-wildlife conflict frequently occurs.

Part III: Species accounts

People have poisoned banteng because they have raided crops, and there were occasions when some individuals attacked people. Due to the significant economic loss from banteng raiding cacao plantations, a plan was undertaken to capture 19 individuals, with nine being sent to a zoo and ten released in Meru Betiri National Park.

Based on the above findings, it is clear that the population and range of banteng in Java has declined significantly. Because of rapid population decline, an urgent conservation plan should be developed to save the banteng population in Baluran National Park. The decline was predicted with a population simulation using Vortex Program (Pudyatmoko 2005). In the model, the author discovered that the key factor of banteng decline was the very low proportion of young in the population. He inferred that dhole may increase the extinction risk of banteng based on the records of predation. Dhole preferred pregnant cows and juveniles to males or non-pregnant adult cows. As a result, he observed that the proportion of subadults and juveniles in the population were underrepresented, and there was a change of sex ratio towards more males in the population. Currently, the number of dhole in Baluran has decreased. Analysis of dhole scat collected during wet and dry seasons showed that no banteng remains were found. This indicated that predation on banteng has also declined (Pudyatmoko 2012).

Bornean banteng

This subspecies has been hunted to extinction in many areas of Borneo as a result of widespread use of guns since the middle of the last century (Payne *et al.* 1985). Other methods of hunting also included wire snares and homemade bomb devices. Hunting using firearms dramatically increased in the 1940s and 1950s, when net importation of shotgun cartridges to Sarawak quintupled from 444,161 to 2,149,556 (Caldecott 1988). In the following 30 years hunting activity showed no sign of slowing down as importation figures for cartridges remained constantly high at more than 1,300,000 (Caldecott 1988). It is probable that the high level of unregulated hunting activity during this time resulted in the loss of many banteng, particularly as the above figures do not account for the manufacture and re-use of illegal shotgun cartridges, which are favoured by poorer rural communities. Based on these facts, it is probable that hunting caused the extinction of banteng in Brunei; however, no information was found in the literature. Banteng are hunted for meat for subsistence, but more often on a contract-basis for celebrations such as weddings or religious public holidays. The poles of banteng are thought to be of Chinese medicinal value, but there is no information describing the type of condition they treat or the mode/method of treatment. Claims on the use of banteng byproducts are unsubstantiated at best and are held in no regard within the scientific medical community at large. Numerous banteng skulls, horns and other body parts were located in villages in Kalimantan during a survey in 1999 (Hedges & Meijaard

1999), and it is probable that there is some international trade in banteng skulls in Borneo, whereby skulls originating from Kalimantan are brought across the border and sold as trophies in Sabah.

Additional threats include extensive deforestation of banteng habitat for timber production and subsequent conversion to monocrop agricultural plantations, which has caused widespread habitat loss and fragmentation of remnant populations (Caldecott 1988). Banteng that inhabit forest which intersects with plantations are at greater risk of encroachment and disturbance from hunters/opportunistic poachers. In Sabah during 2011–2013, hunters, fishermen and harvesters were observed on many occasions within protected forest reserves. In these areas extensive trail networks had been created and were regularly maintained to facilitate illegal activity (P. Gardner, personal observation).

As a result of habitat fragmentation, the isolation of banteng populations prevents gene flow and renders them highly susceptible to inbreeding, which may result in a lack of genetic diversity and increase their susceptibility to genetic mutation and disease. Banteng that inhabit forest in close proximity to oil palm plantations are at further risk of disease transmission from domestic cattle and water buffalo, which are used to maintain scrubland within the plantation and assist harvesters with the transportation of fruit bunches. These domestic bovids are often grazed along the plantation edge and river banks which are also used by banteng; in Eastern Sabah in 2012 banteng were found to be only 100–200 metres away from domestic cattle (P. Gardner, personal observation). Such close proximity suggests disease transmission and hybridization between domestic and wild cattle to be a real threat.

In Kalimantan, banteng are vulnerable to hunting and are also at risk of disease transmission and hybridization because they inhabit areas that occur outside of conservation areas (Timmins *et al.* 2008; Pudyatmoko *et al.* 2012). These conflict areas are often used for cultivation by local villages; however, the banteng are not thought to cause damage to crops (Pudyatmoko *et al.* 2012).

Status in captivity

By the end of 2010 there were 138 banteng consisting of 43 females and 95 males in captivity centres worldwide (<http://app.isis.org/abstracts/abs.asp>). According to the Ministry of Forestry Decree of Republic Indonesia Number 58 on Strategy and Conservation Action of Banteng from 2010 to 2020, in Indonesia there were 56 banteng in conservation institutions consisting of 30 females and 26 males. The breeding centre with the largest number of individuals is Ragunan Zoo in Jakarta, with 21 animals. However, the sex ratio was far from ideal at 16 males and five females. A similar situation was found in the third breeding centre in Surabaya Zoo, which houses 12 banteng comprising seven males and five females. The situation was improved in Taman Safari Prigen with 16 individuals and a sex ratio of five males and 11 females.

Inbreeding depression was very pronounced in Ragunan Zoo. For genetic improvement of captive banteng, animal exchange among the breeding centres and the addition of new wild individuals are highly recommended.

In Thailand, mainland banteng are found in four zoological parks with a total of 32 individuals (male:female ratio 15:17). The species is also found in two wildlife breeding stations with 18 individuals, i.e. Khao Kor Wildlife Breeding Station (2:1) and Khao Nampoo Wildlife and Nature Education Station (15) in the Department of National Park and Wildlife and Plant Conservation.

Data from EEP (EAZA), ISB (WAZA) SEAZA breeding programmes are probably an underrepresentation of the total number of banteng in captive collections (see also Chapter 27).

To our knowledge, no known populations of Bornean banteng (*B. j. lowi*) exist in captivity or in semi-free-range conditions.

Acknowledgements

PG, LA and BG thank Houston Zoo (P. Riger), Sime Darby Foundation, the Malaysian Palm Oil Council, the Mohamed bin Zayed Species Conservation Fund and Woodland Park Zoo for supporting their research on the Bornean banteng in

Sabah. PG and BG thank the Sabah Biodiversity Centre for allowing them to carry out research in Sabah, and the Sabah Forestry Department, which gave them permission to work in Malua Forest Reserve and Tabin Wildlife Reserve. PC, LA and BG also extend thanks to the following organizations for their support during their work on banteng in Sabah: the NGO HUTAN, Malua BioBank, Sabah Foundation, Leibniz Institute for Zoo and Wildlife Research, Borneo Rhino Alliance, and the following individuals for allowing us to use their camera trap pictures: Andrew Hearn, Joanna Ross, Andreas Wilting, Torsten Bohm and Jedediah Brodie.

SP is indebted to many institutions for their help during his research on banteng. He would like to express his appreciation to the Ministry of Forestry, Indonesia, which permitted him to conduct field research in Baluran National Park. He wishes to thank Nagao Environmental Foundation, Japan, for the financial support for his research. For data collection in the field he would like to thank his students Sugiarto, Mohammad Eko Nurcahyono, Nur Bambang Saputra, Haruna Nur Sasongko, Ali Bosar and Teja Suryo Nugroho. Finally, he would like to thank the Faculty of Forestry, Universitas Gadjah Mada, Indonesia for permission to use the Laboratory of Wildlife Management.

2.3 References

References

- Alikodra, H. S. & Sastradipraja, D. (1983). Studi Tentang Beberapa Parameter Faal Pelestarian Satwa Banteng (*Bos javanicus*). [Study on Some Physiological Aspects of Banteng]. Research Report, Faculty of Veterinary Animal, Institute Pertanian Bogor, Indonesia.
- Bhumpakphan, N. & McShea, W. J. (2011). Ecology of gaur and banteng in the seasonally dry forests of Thailand. In *The Ecology and Conservation of Seasonally Dry Forests in Asia*. pp. 179–194. Eds. McShea, W. J., Davies, S. J. & Bhumpakphan, N. Washington, DC: Smithsonian Institution Scholarly Press.
- Byers, O., Hedges, S. & Seal, U. S. (1995). *Asian Wild Cattle Conservation Assessment and Management Plan Workshop*. Apple Valley, MN: IUCN/SSC Conservation Breeding Specialist Group.
- Caldecott, J. O. (1988). *Hunting and Wildlife Management in Sarawak*. Switzerland and Cambridge: IUCN Tropical Forest Programme.
- Choquenot, D. (1993). Growth, body condition and demography of wild banteng (*Bos javanicus*) on Couburg Peninsula, Northern Australia. *Journal of Zoology* 231: 533–542.
- Corbet, G. B. & Hill, J. E. (1992). *The Mammals of the Indomalayan Region: A Systematic Review*. Oxford: Oxford University Press.
- Davies, G. & Payne, J. (1982). *A Faunal Survey of Sabah*. Malaysia: World Wildlife Fund.
- Francis, C. M. (2008). *A Field Guide to the Mammals of Southeast Asia*. London: New Holland Publisher (UK) Ltd.
- Grzimek, B. (1987). *Grzimek Enzyklopädie Säugetiere: Register*. Zürich: Kindler Verlag AG.
- Halder, U. (1976). *Ökologie und Verhalten des Banteng (Bos javanicus) in Java*. Hamburg: Verlag Paul Parey.
- Hassanin, A. & Ropiquet, A. (2006). What is the taxonomic status of the Cambodian banteng and does it have close genetic links with the Kouprey? *Journal of Zoology* 271: 246–252.
- Hedges, S. & Meijaard, E. (1999). *Reconnaissance Survey for Banteng (Bos javanicus) and Banteng Survey Methods Training Project*. East Kalimantan: Kayan-Mentarang National Park.
- Hedges, S. & Tyson, M. (1996). Is predation by ajag a threat to the banteng population in Alas Purwo? Review of the evidence and discussion of management options. Research report. Faculty of Forestry, Universitas Gadjah Mada, Indonesia.
- Hoogerwerf, A. (1970). *Ujung Kulon, the Land of the Last Javan Rhinoceros*. Leiden: E. J. Brill.
- IUCN (2013). *IUCN Red List of Threatened Species*. Version 2013.2. www.iucnredlist.org, downloaded 22 May 2014.
- Lekagul, B. & McNeely, J. A. (1988). *Mammals of Thailand*. 2nd edition. Bangkok: Darnshutha Press.
- Lydekker, R. (1913). *Catalogue of the Ungulate Mammals in the British Museum (Natural History)*. Vol. 1: Artiodactyla, Family Bovidae, Subfamilies Bovinae to Ovibovinae (Cattle, Sheep, Goats, Chamois, Serrows, Takin, Musk-Oxen, etc.). London: British Museum (Natural History).
- Manatchaiworakul, W., Treeraditthakul, W., Kidsin, K., et al. (2011). Genetic variation study of mtDNA of Wild Bovid in Khao Ang Rue Nai Wildlife Sanctuary. Poster presentation, Wildlife Seminar of Thailand.
- Medway, L. (1983). *The Wild Mammals of Malaya (Peninsular Malaysia) and Singapore*. Oxford: Oxford University Press.
- Medway, L. (1969). *The Wild Mammals of Malaya*. Kuala Lumpur: Oxford University Press.
- Nakhasathien, S., Bhumpakphan, N. & Simcharoen, S. (1987). *Ecology of the*

Part III: Species accounts

- Wildlife in Thung Yai and Huai Kha Khaen Wildlife Sanctuaries*. Bangkok: Wildlife Conservation Division, Royal Forest Department.
- National Research Council. (1983). *Little-known Asian Animals with Promising Economic future*. Washington, DC: National Academy Press.
- National Research Council (2002). *Little-known Asian Animals with a Promising Economic Future*. New York: Books for Business.
- Nijman, I. J., Otsen, M., Verkaar, E. L., et al. (2003). Hybridization of banteng (*Bos javanicus*) and zebu (*Bos indicus*) revealed by mitochondrial DNA, satellite DNA, AFLP and microsatellites. *Heredity* 90(1): 10–16. Available at: <http://www.ncbi.nlm.nih.gov/pubmed/12522420> (accessed 13 February 2013).
- Pairah (2007). Tumpang tindih relung ekologis Banteng (*Bos javanicus*, d'Alton 1823) dan Rusa Timor (*Rusa timorensis*, Blainville 1822) di padang penggembalaan Sadengan, Taman Nasional Alas Purwo, Jawa Timur. [Ecological niche overlap between banteng and rusa timor in grassing area, Baluran National Park, East Java]. Masters thesis. Fakultas Kehutanan Universitas Gadjah Mada. (In Bahasa Indonesia)
- Payne, J., Francis, C. M. & Phillips, K. (1985). *A Field Guide to the Mammals of Borneo*. Malaysia: The Sabah Society.
- Pedrono, M., Ha Minh, T., Philippe, C. & Frederi, V. (2009). Status and distribution of the endangered banteng *Bos javanicus birmanicus* in Vietnam: a conservation tragedy. *Oryx* 43(4): 618–625.
- Prayurasithi, T. (1987). Ecology of banteng in Huai Kha Khaeng Wildlife Sanctuary. MSc thesis. Kasetsart University.
- Prayurasithi, T. (1997). Habitat partitioning between gaur and banteng in Huai Kha Khaeng Wildlife Sanctuary. PhD thesis. Minasota State University.
- Pudyatmoko, S. (2005). *Freilanduntersuchungen zur Ökologie und Habitatnutzung Wildlebender Banteng Rinder (Bos javanicus) im Baluran National Park in Ost Java, Indonesien*. Goettingen: Cuvillier Verlag.
- Pudyatmoko, S. (2012). Influence of dhole (*Cuon alpinus*) on population and distribution of banteng in Baluran National Park. Research Report. Faculty of Forestry UGM-Nagao Environmental Foundation.
- Pudyatmoko, S. et al. (2012). *National Strategy and Action Plan for Banteng (Bos javanicus) Conservation 2010–2020*. Kalimantan: Ministry of Forestry.
- Samejima, H., Ong, R., Lagan, P. & Kitayama, K. (2012). Camera-trapping rates of mammals and birds in a Bornean tropical rainforest under sustainable forest management. *Forest Ecology and Management* 270: 248–256.
- Steinmetz, R. (2004). Gaur (*Bos gaurus*) and banteng (*Bos javanicus*) in the lowland forest mosaic of Xe Pian Protected Area in Lao PDR: abundance, habitat use and conservation. *Mammalia* 68: 141–157.
- Timmins, R. J., Duckworth, J. W., Hedges, S., Steinmetz, R. & Pattanavibool, A. (2008). *Bos javanicus*. In *IUCN 2013: IUCN Red List of Threatened Species*. Version 2013.2. www.iucnredlist.org, accessed 4 March 2013.
- Tun Yin, U. (1967). *Wild Animals of Burma*. Rangoon: Rangoon Gazette.
- van den Bergh, G. D., De Vos, J. & Sondaar, P. Y. (2001). The Late Quaternary palaeogeography of mammal evolution in the Indonesian Archipelago. *Palaeogeography, Palaeoclimatology, Palaeogeology* 171: 358–408.
- Whitemore, T. C. (1990). *An Introduction to Tropical Rainforests*. 2nd edition. Oxford: Oxford University Press.
- Whitten, T., Soeriaatmadja, R. E. & Affif, S. A. (1996). *The Ecology of Java and Bali*. Singapore: Periplus Ltd.
- Wilson, D. E. & Mittermeier, R. A. (2011). *Handbook of the Mammals of the World*. Vol. 2. Hoofed Mammals. Barcelona: Lynx Edicions.

Chapter 3: Until the cows come home; effective non-invasive sampling of the rare Bornean banteng (*Bos javanicus lowi*)

3.1 Abstract

Traditional sampling methods are often unsuitable for low-density species like the Bornean banteng, and the effectiveness of non-invasive sampling methods is questionable. Estimates of population sizes derived using data from ineffective methods can be inaccurate and could result in species mis-management. I collected the first baseline data on the rare Bornean banteng in two forests, Tabin Wildlife Reserve and Malua Forest Reserve, using a comparison of non-invasive sampling methods (camera traps and sign surveys) to identify method efficiency and suitability, and to estimate additional sampling effort and preliminary population size. Detection success, influenced by biotic and abiotic conditions, was estimated using Generalised Estimation Equations [transformed to the Ratio of Odds]. All individuals were identified according to three scenarios to account for identification-heterogeneity and to estimate observed population size (N_{obs}). Accumulation curves were used to estimate the observed population size (N_{obs}), and extrapolation of N_{obs} using non-parametric estimators (Chao, jack knife and bootstrapping) provided estimated population size (N_{est}). I estimated increments in sampling units (camera stations and survey days) using Chao1, and estimated additional sampling effort required to observe 95% and 99% of N_{est} using Chao2. The presence of banteng was identified from 99 captures over 23,424 camera trap nights. Camera traps provided consistent detection in difficult environmental conditions whilst sign surveys were less efficient in an open canopy that accelerated erosion of tracks. Identification heterogeneity magnified population size estimates using non-parametric estimates. Based on realistic estimates, my surveys may have failed to detect a few individuals, with estimated population size between N_{est} 16-20 for Malua Forest Reserve and N_{est} 19-27 for Tabin Wildlife Reserve. Due their use of highly disturbed habitat, the majority of the banteng identified are highly vulnerable to eradication as a result of hunting and habitat loss.

3.2 Introduction

3.2.1 Non-invasive sampling methods

The endangered Bornean banteng (*Bos javanicus lowi*) is rarely seen in Sabah and collecting data on their presence and use of habitat is challenging due to their shy behaviour. Identifying

suitable survey methods for this large bovid should be an informed decision based on the performance and effectiveness of the technique (Espartosa et al., 2011). In tropical forests sampling methods are subject to and influenced by extreme climatic conditions and seasonality which may decrease the relative effectiveness of detection during sampling (Pedersen & Weng, 2013; Swan et al., 2013). Recently, emphasis placed upon the issue of detection probability has become commonplace in studies using non-invasive survey methods (Bailey et al., 2007; Mackenzie & Royle, 2005; Mackenzie et al., 2002; Mackenzie et al., 2010; Royle et al., 2005; Stanley & Royle, 2005). This approach has been applied to numerous species including the banteng in Cambodia (*Bos javanicus birmanicus*) (see Gray 2012). The implications of detection probability are wide-reaching; effective survey methods with higher detection probabilities will produce more robust population parameters and, in turn give rise to more accurate bio monitoring programmes which could potentially affect long-term conservation outcomes (Pinna et al., 2014; Swan et al., 2013).

A non-invasive multi-method approach is the most appropriate way to survey large ungulates that are rarely sighted (Sollmann et al., 2013; Zero et al., 2013) and suitable techniques include track plot recording in sand, camera trapping, and dung counts (Espartosa et al., 2011; Gopaldaswamy et al., 2012; Lyra-Jorge et al., 2008). The accuracy of non-invasive survey methods is questionable however (Lyra-Jorge et al., 2008), and multi-method approaches provide a good indication of method performance (see Brook et al., 2012; Kamler et al., 2012; Rönnegård et al., 2008; Thorn et al., 2009). Remote sensor camera traps are particularly useful for animals which are rarely seen (O'Connell et al., 2011) and can complement other methods such as track-plot counts, hair snares and molecular studies. Previous studies of the Burmese banteng in Cambodia (*B. j. birmanicus*) successfully utilised camera traps to estimate occupancy (Gray 2012) and direct observations to estimate population density (Gray et al., 2012) and both accounted for detection probabilities. Parallel evaluation of the suitability and performance of the different survey methods is yet to be conducted however, and the accuracy of their parameters is unsubstantiated. With respect to other taxa, a wide variety of studies have used multi-method non-invasive studies to investigate both small and large mammals including pine martens (*Martes martes*) (Rosellini et al., 2008), Eurasian otter (*Lutra lutra*) (Hájková et al., 2009), red fox (*Vulpes vulpes*) (Vine et al., 2009), Neotropical wild felids (Portella et al., 2013), brown hyaena (*Hyaena brunnea*) (Thorn et al., 2009), dhole (*Cuon alpinus*) (Kamler et al., 2012) and Javan rhinoceros (*Rhinoceros sondaicus annamiticus*) (Brook et al., 2012). The reliability of non-invasive

methods was investigated by Rönnegård et al., (2008) to derive estimates of population size of the moose (*Alces alces*) in Sweden. Density estimates calculated from hunter observations, aerial counts, pellet group count and direct observations were compared and the population structure was recreated over the past 30 years using a cohort analysis. Aerial counts provided a precise indicator of population size, whilst pellet group counts provided a more general index of population density and population trend due to annual changes in forage availability that affected defecation rates. Hunter observations were a useful indicator of demography and, depending on the size of the area covered, a useful tool for estimating long-term population trends (Rönnegård et al., 2008). Estimates of population density using mixed methods were also investigated by Trolle et al., (2008) but for the Brazilian tapir (*Tapirus terrestris*). Trolle et al., (2008) compared density estimates using a capture-recapture framework with images taken from camera traps and direct observations of tapir along five line-transects. Detection of tapir using camera traps far exceeded that of line-transects, furthermore most captures were recorded at night when direct observations would have been near impossible under a dense forest canopy. The lack of recaptures of individuals was thought to be a reflection of the short trapping period. Additional effort and sampling design adaptations included decreasing the spacing between camera traps to increase re-capture efficiency, increase the survey duration and shift placement of camera traps to tapir trails as opposed to roads, salt licks and waterholes (Trolle et al., 2008).

The use of remote sensor camera traps provides a non-invasive method of detecting and photographing a species over a continuous period without the need for human presence and direct observations. They are particularly valuable for confirming and documenting the presence of endangered animals which are rarely seen (O'Connell et al., 2011), and can be used to address many basic ecological questions relating to species diversity, behaviour, and habitat use. Due to their ability to operate for extended periods without the need for maintenance, camera traps have successfully been used to study a wide range of tropical species from the very common to the very rare and, in specific circumstances, they have also been used to identify individuals, estimate abundance and model estimates of occupancy (Karanth & Nichols 1998; De Luca & Rovero 2006; Tobler et al., 2009; Karanth et al., 2010; Espartosa et al., 2011; Tobler et al., 2008). The first application of camera traps to the study of the Javan banteng (*B. javanicus javanicus*) was by van Schaik and Griffiths (1996) in Java, who used camera traps to describe their activity patterns according to forage availability and body size. Similarly, but in more recent years, camera traps were used to document the

presence of the Burmese banteng in Cambodia, examine their activity patterns, and confirm their status and their habitat preferences (Phan & Gray 2010; Gray & Phan 2011).

As with any monitoring technique, there are drawbacks to the use of camera traps. These generally arise from failure to detect the species due to avoidance of the trap by the species or bad placement by the user, electronic failure and detection failure due to harsh weather and environmental conditions. Detection by non-invasive survey methods is confounded by an array of factors, namely a large study area which will decrease the likelihood of locating the species, and the nature of the habitat and the density of ground vegetation which will inhibit visibility and conceal movement of individuals (Espartosa et al., 2011). Also, the substrate composition, soil moisture content and degree of canopy cover which may affect the degree of indentation of footprints and the rate at which they are eroded by weathering (Espartosa et al., 2011), whilst the elevation and slope of the terrain will increase the difficulty in conducting ground surveys and may even restrict the movement of banteng. Decomposition of faeces is also likely to be accelerated in tropical forests that experience high levels of humidity and rainfall, thus the period of time available for observation is shortened. Weathering and environmental conditions will undoubtedly affect the observation process and detection of tracks, faeces and even individuals (Gopaldaswamy et al., 2012), and can lead to the under-estimation of population size and inaccurate portrayal of population trends. Conversely, over-estimation of population size may occur from repeated observations (e.g. of multiple faeces deposited by a single individual or of a single individual moving across a survey area over a period of time). Accounting for deposition and decomposition rates of faeces is an important factor for estimating population size however these can be difficult to estimate, particularly when encounters of faeces are infrequent. For these reasons sign surveys are often combined with other non-invasive techniques such as camera trapping (Mondol et al., 2009) and molecular analysis (Ruibal et al., 2010; Brook et al., 2012) to provide more robust population estimates. Reducing or accounting for the likelihood of spatial autocorrelation of individuals (e.g. [undesirable] repeated observations of an individual or group of individuals across the survey area) recorded using direct observations is essential for estimating the population size of highly mobile large mammals. For species like the banteng, the ability to identify individuals without prominent unique markings during the direct observation process is near impossible. If the individuals are not identifiable then the spacing of sampling units, be that line transects or camera traps, must reflect the ranging behaviour of the target species if parameter estimates are to be accurate. Multiple sampling

units within the home range of an individual(s) could lead to repeated sampling of individuals and result in the gross overestimation of population size.

3.2.2 Non-invasive sampling of banteng

The estimation of banteng population parameters using non-invasive survey methods has largely been undertaken in Cambodia. The population density of Cambodian banteng (*B. j. birmanicus*) was estimated by Gray et al., (2012) who used direct observations recorded using a distance-based framework along line transects in two forest reserves. A total of 110 randomly stratified transects covered a distance of 1,310 km² and were walked at dusk and dawn, during which time the requisites of each observation were recorded. Gray et al., (2012) incorporated a detection function, whereby the detection probability decreased when the distance between the herd and the transect increased (Thomas et al., 2010). Other assumptions detailed by Thomas et al., (2010) included certainty of detection, precision of distance measurements, and movement of individuals across the survey area but also responsive movement of individuals to disturbance caused by human presence required for sampling. “Distance sampling is a snapshot method”, assuming animals are frozen in place during the survey period (Thomas et al., 2010). The duration of the survey is of great importance however as it must be short enough to prevent movement of individuals between transects but long enough to complete the survey. The density estimates per km² were calculated using the cluster size of each observation and the distances between herds and transects. Gray et al., (2012) extrapolated the group density, individual density and cluster size to estimate a mean population size of 3201 ± 703 (1982-5170 95% Confidence intervals). If correct, the two forest reserves in Cambodia contain the largest global subpopulation of the Burmese banteng. This estimate also exceeds the total population size of all banteng subspecies combined. Whilst Gray et al., (2012) uses “robust sampling methodologies” the intensity of the line transects and the distance between neighbouring transects, evident from the map in Gray et al., (2012) together with the long survey period spanning the “dry seasons” probably increased the likelihood of overrepresentation of certain areas of the habitat. Banteng herds and individuals were probably repeatedly sampled because they are highly mobile animals capable of wide-ranging movement across a home range of 20-44 km² (Prayurasithi 1997, In Bhumpakphan & Mcshea 2011; Gopaldaswamy et al., 2012). Banteng in Borneo are also known to move long distances of at least 10km in dense tropical forest over a period of months (Melletti & Burton 2014), whilst daily movement can exceed 1.5km in seasonal freshwater swamp and lowland dipterocarp forest

(P. Gardner, pers. obs.). It is possible that the population density estimate was positively biased as a result of unintended repeated sampling of banteng, and the extrapolated population size was grossly overestimated. Without comparable sampling it is difficult to assess the reliability of the estimate. In such situations, multi-sampling can be advantageous because it will identify the optimal method, and ensure data is collected by one or both methods.

The endangered Bornean banteng is the least documented of all banteng subspecies, and baseline data for the population within Sabah are absent. No conservation or monitoring programme exists and there is a pressing need for data on population parameters, distribution and behaviour to empower the local wildlife and forestry government authorities. Piece-meal studies on banteng had reportedly been attempted intermittently over the past two decades however detailed information on these is not currently in circulation. From the few published studies available, banteng is largely a non-target species recorded incidentally. Comparisons between studies did not identify one consistent survey design specifically for banteng and detection success did not appear to be incorporated as an indicator of sampling efficiency. Identifying or developing a survey method for banteng, which is precise but also time and cost-effective is crucial for estimating accurate population parameters (Lyra-Jorge et al., 2008; Zero et al., 2013) and will facilitate the preparation of a state Action Plan for banteng in Sabah. To increase survey efficiency I contrasted the detection probability of two non-invasive survey methods, camera traps and sign survey, in two forests. I tested the hypotheses that the detection success of camera traps would be superior but that the detection success of sign surveys would i) increase with survey duration, ii) decrease as elevation increased and iii) be lower in swamp habitat and in a closed canopy. All individuals were identified from camera trap photos using variation in pelage, horns and scars, and classified according to three scenarios which accounted for identification heterogeneity. Random permutations of recapture histories without replacement were fitted to incidence-based accumulation curves to identify the effect of identification heterogeneity on the population size asymptotes. Population sizes were estimated using random permutations of the data without replacement using four variations of non-parametric estimators. Using the estimator with the smallest available standard error, simulated increments of ten sampling units were used to identify when the population size was near complete. Using a variant of this estimator, I extrapolated to estimate 95% and 99% of the true population size and the additional sampling effort

required to observe these. Finally, realistic minimum and maximum population sizes were estimated from the observed and extrapolated population sizes.

3.3 Methods & Study Sites

3.3.1 Study Areas

Tabin Wildlife Reserve (5° N, 118° E) is located on the Dent peninsular on the east coast of Sabah (East Malaysia), 45km east of Lahad Datu. Tabin Wildlife Reserve (Figure 3.1) encompasses 1,123.65 km² of tropical forest; 3.94 km² patch of primary (unlogged) forest surrounded by 1,119.71 km² of secondary (logged) forest. Tabin was extensively logged up until 1989 using conventional harvesting methods which created a vast network of skid trails (Sabah Forestry Department 2005) and facilitated secondary access. Vegetation regeneration success varies considerably. The presence of banteng was first documented by Davies & Payne (1982) however their precise population size remains unknown. Tabin is geographically isolated by oil palm (*Elaeis guineensis*) plantations except for a section of the north border, which connects with wetland habitat, including nipah palm (*Nypa fruticans*) and mangrove (*Rhizophora and Bruguiera*) forest. There is no evidence to suggest that banteng utilise nipah forest or oil palm plantations, and no observations were made in these habitats during the course of this study. For these reasons it is believed that the population of banteng in Tabin is geographically and genetically isolated with no emigration or immigration of banteng due to a lack of wildlife corridors connecting neighbouring reserves (Kulamba and Silabukan). The vegetation composition of Tabin varies from mixed primary and secondary tropical lowland dipterocarp forest, (seasonal and non-seasonal) freshwater lowland swamp forest and mangrove forest. Along the borders are grass-rich roadside verges and on the west border there is a large private grassland area, maintained by an oil palm plantation. Banteng are able to inhabit primary, secondary and swamp forest because they browse and graze, however they are drawn to openings and quiet roadside verges to forage on grasses and young herbs and vines, particularly after rainfall when vegetation softens (Timmins et al., 2008; Melletti & Burton 2014). The topographical gradient of Tabin is moderate to steep (maximum height is Mt Hatton, 570m) in the north-west and southern half, whereas in the north-east and east the land is significantly flatter and prone to severe flooding (Sabah Forestry Department 2005). Previous observations classified banteng as a lowland species (Davies & Payne 1982) however signs have recently been observed at elevations >1,000m in

the interior region of Sabah and would suggest otherwise (P. Gardner, pers. obs.). It is therefore likely that banteng also inhabits the hill forest within Tabin.

Malua Forest Reserve (5° N, 117° E) is located in the southeast of Sabah on the outskirts of Lahad Datu, north of Danum and acts as a buffer zone for Danum Valley Conservation Area. Banteng are known to occur in Malua and in Danum Valley (Timmins et al., 2008), and as the two forest reserves are connected (southern border of Malua with the northern border of Danum) it is highly probable that there is some level of immigration and emigration. Malua Forest Reserve is classed as secondary forest and was last logged at the end of 2007 (Ancrenaz et al., 2010) using a combination of conventional or traditional (crawler tractor), and reduced impact logging (RIL) techniques including heli-logging in higher elevations and also log-fisher logging. Malua spans 339.96 km² and is a certified FSC (Forest Stewardship Council) sustainable commercial logging forest reserve. Vegetation of Malua comprises (in order of dominance) tropical mixed lowland dipterocarp forest, upland mixed dipterocarp forest, secondary forest and freshwater swamp forest. Large areas are severely degraded with little regeneration as a result of excessive logging. Forest fires as a result of logging have also decreased plant diversity and large areas are dominated by scrub, vines, bamboo and grasses. The regeneration and increased availability of grasses, particularly in old stumping grounds (timber storage and processing sites) and along abandoned logging roads has inadvertently created a rich foraging ground for banteng. The surface temperatures in Malua are much higher than in Tabin (max. temp observed from camera trap photos of banteng 44°C and 34°C, respectively) and this is probably due to a reduction in leaf cover (Pinard, et al., 1996). High temperatures cause the banteng to retreat to dense canopy where they can avoid thermal-stress and dehydration (Chapter 4).

Overall, the differences between the two study sites are defined primarily by their locale and connectivity with neighbouring forests and not by their habitat type; in Tabin no immigration or emigration of banteng occurs because it is an isolated reserve and disconnected with other designated forest, whereas Malua connects with other forest reserves that encompass the largest continuous patch of forest in Sabah, therefore movement of banteng can and does occur between designated reserves.

3.3.2 Non-invasive multi-sampling using camera traps and sign surveys

Four grids of camera traps were situated in the north, east, south and west borders of Tabin Wildlife Reserve (Figure 3.2) and three in the south, east and north of Malua Forest Reserve

(Figure 3.3). The precise location of each grid was determined by access to the area identified on a reconnaissance expedition prior to any surveying activity. A maximum travel distance of 10km by a bull was observed in 2011 (Melletti & Burton 2014), therefore a minimum distance of 10km was maintained between grids to avoid resampling of the same herd. Two grids in Tabin Wildlife Reserve comprised 25 camera trap stations (50 camera trap units), whilst the remaining two grids in Tabin Wildlife Reserve and three grids in Malua Forest Reserve were enlarged to incorporate 36 camera trap stations (72 camera trap units). Each grid was accessed by trails that were cut specifically to connect camera trap stations. Camera trap stations were spaced at approximately 500m and locations were not selected based on any other prior knowledge or criterion, thus could be considered as randomly stratified units. Distances between camera trap stations were considerably shorter than those of other studies, 2-4km (Gray 2012) and 2km (Tobler et al., 2009) and were purposely designed to maximise the chance of detecting any individuals within the area. Grids of camera traps operated for 12 weeks minimum and were checked every four weeks. Two cameras were positioned at each station, and positioned perpendicular to a trail or signs to capture both sides of an individual. Cameras were set to operate 24 hours, capturing three images per activation (one image per second), and all photographs were digitally stamped with the time, date, and temperature. Camera traps were positioned at a height 100-150cm to ensure the sensor coincided with the body of an adult banteng.

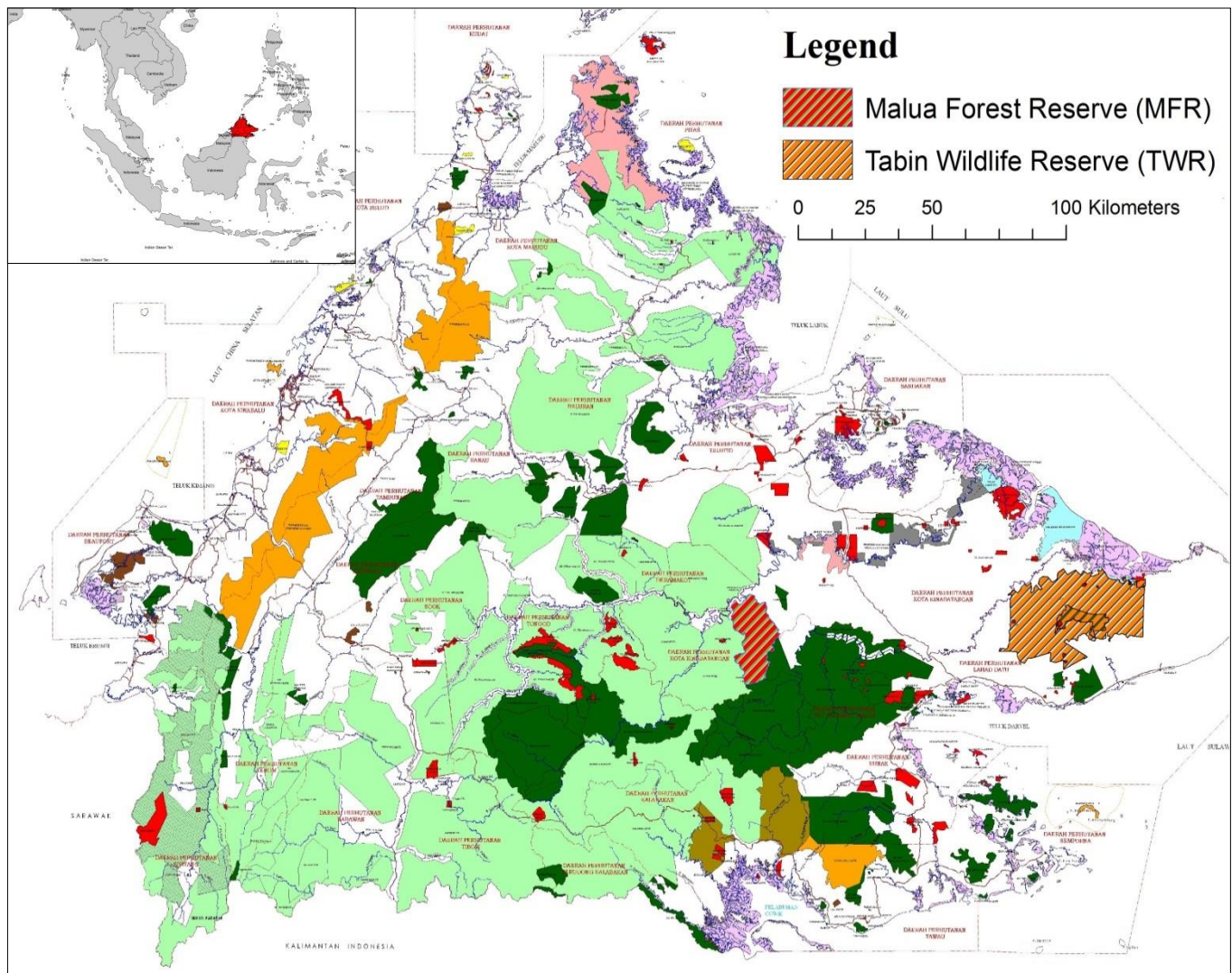

Figure 3.1: The location of Sabah (inset) and a map of Sabah with the locations of the two study sites in the central and east regions, which are categorised primarily by tropical lowland dipterocarp forest and contain banteng. In the central region of Sabah is Malua Forest Reserve, an FSC (Forest Stewardship Council) certified forest with a recent history of sustainable logging practices, and in the east is Tabin Wildlife Reserve, a fully protected wildlife Sanctuary with no logging activity since the late 1980s. Note, other colours relate to forest classification designated by the Sabah Forestry Department: Virgin jungle reserve (red), protected forest reserve (dark green), commercial forest reserve (light green), Sabah parks (orange), wildlife reserve (light blue), mangrove forest reserve (pink), and amenity forest reserve (brown).

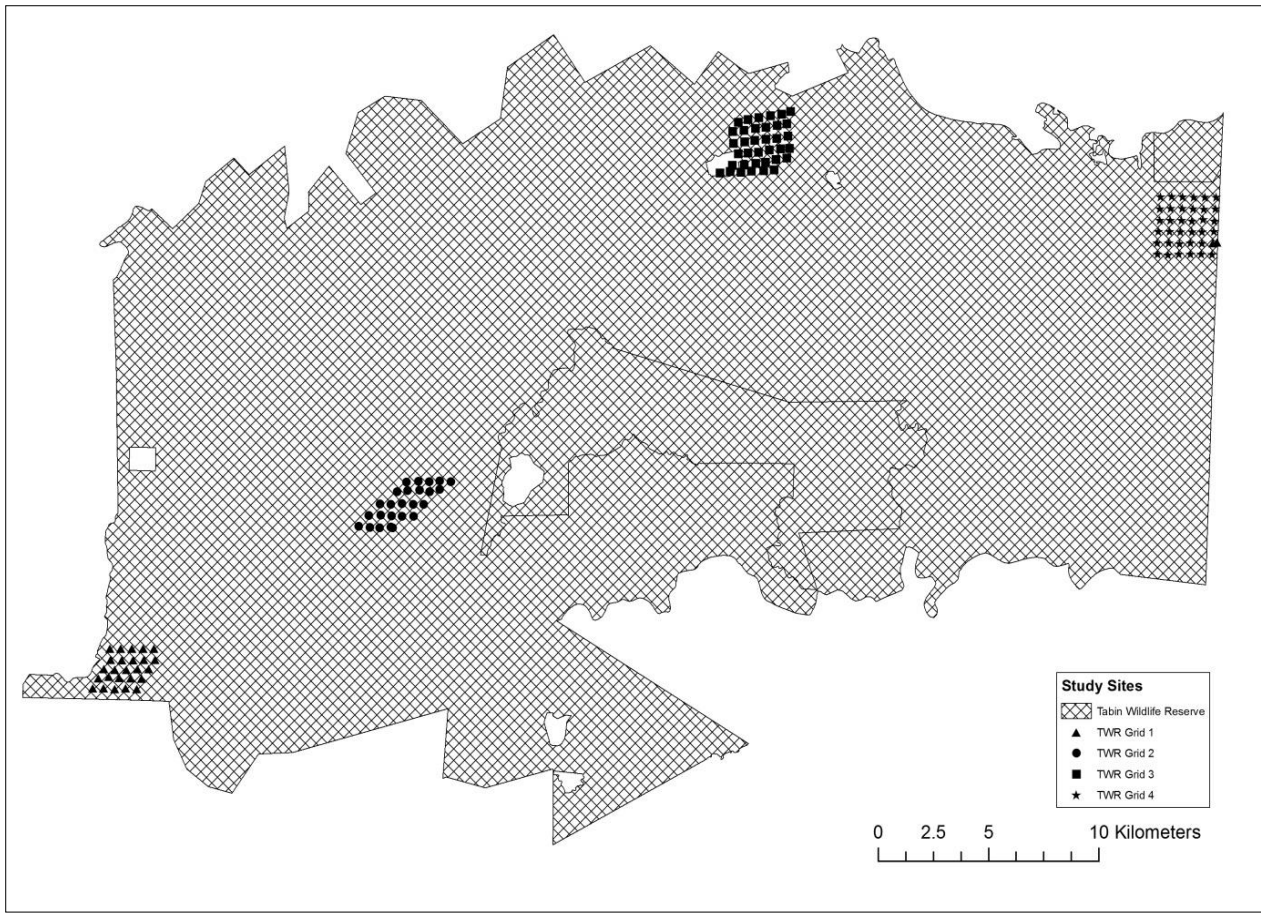

Figure 3.2: Map of the fully protected wildlife sanctuary Tabin Wildlife Reserve in the east of the Malaysian state of Sabah with secondary forest in hash and a central core classified as a forestry reserve (outlined by black) and a patch of virgin forest (white patch in centre). The map shows the positions of the four grids where camera trap and sign surveys were conducted (defined by different symbols) that were segregated by a minimum of 10km to avoid autocorrelation.

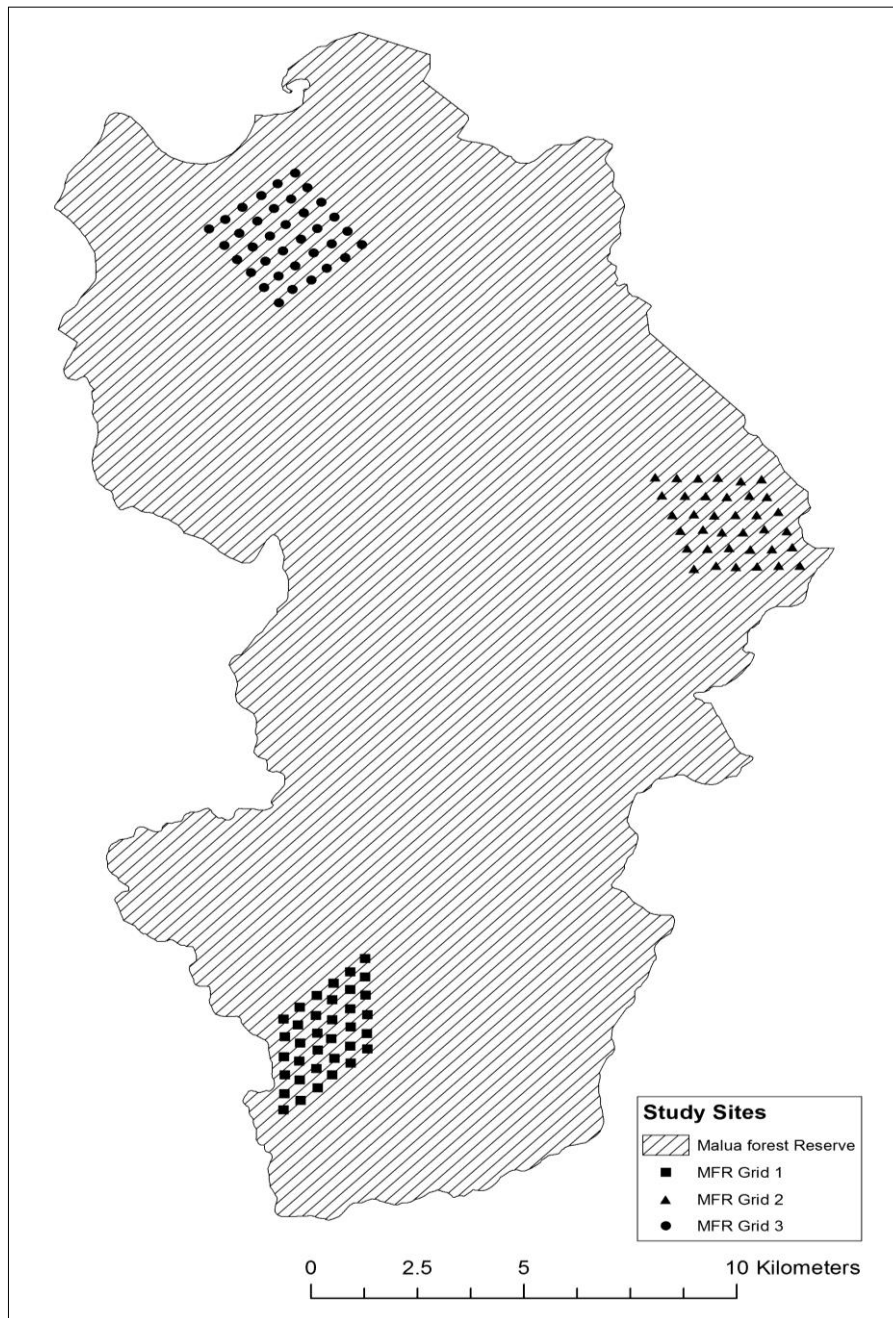

Figure 3.3: Map of Malua Forest Reserve, a commercial timber forest with FSC (Forest Stewardship Council) certification for sustainable logging practices. The forest is primarily secondary lowland dipterocarp and characterised by a vast network of abandoned logging roads. The map shows the locations of the three grids (defined by different symbols) where camera trap and sign surveys were conducted, with each grid segregated by a minimum distance of 10km.

Sign surveys for tracks and faeces were conducted every four weeks within a $\pm 5\text{m}$ radius of each camera trap station to coincide with checks of the camera traps. All signs were logged using a GPS and cross-checked with previous records to prevent pseudo-replication. Basic habitat type of each station was categorised according to flora composition of one of two forest types: lowland dipterocarp forest or seasonal freshwater swamp forest which contained characteristics of mangrove forest. Percentage leaf cover was extracted from photographs of the canopy, taken directly above each station using a Samsung WP10 waterproof all-weather 12.2MP x5.0 digital zoom compact camera on minimum optical zoom. Percentage leaf cover was estimated from monochrome photographs using the software Leaf Cover Calculator version 1.0 (MacDonald 2012).

3.3.3. Detection success and effectiveness of sampling

The most effective sampling method and the effect of survey duration and environmental conditions upon detection was estimated using a binomial Generalised Linear Model (GLM) fitted via Generalised Estimation Equations (GEE) in RGui version 3.1.0, which is appropriate for binomial datasets that are characterised by within-cluster correlation and longitudinal correlation (i.e. repetitive sampling across time) (Vaughan et al., 2007). Sign and camera trap surveys were conducted every four weeks however due to the statistical method used and to the lack of independence of consecutive surveys it was not appropriate to model each survey separately. The surveys were pooled to a single 12-week sampling period with one (presence/absence) value for each survey method (camera traps and sign surveys) at each station. This reduced the magnitude of longitudinal correlation. Due to variation in the survey dates of each grid, it was not possible to address questions about changes in detection over time. I modelled a main effect between the detection of banteng and the survey method, with an interaction between the survey method and the survey duration. A second model specified a main effect between the detection of banteng and the survey method, with interactions between the survey method and canopy cover, and habitat type. I further controlled for longitudinal correlation between stations by including the nested sampling location as a random term. Final models were selected based on backwards deletion of non-significant terms and interactions. I used an ANOVA of the Wald statistic to compute significance values of terms and interactions. GEEGLM estimates and standard errors were converted to the Odds of Ratio (OR) because they can be somewhat easier to interpret, where the odds of a species being detected using one of the two survey methods was the ratio of the probability that it was present relative to the probability that it was absent (Vaughan et al., 2007).

3.3.4 Accumulation curves

Profiles and a capture history were created for every recognisable individual using scars or other unique features (Figure 3.4). Individuals that were unidentifiable due to obscurity or lowlight were recorded at a frequency of one observation. Three scenarios were created that accounted for identification heterogeneity and were named according to success from an identification perspective (i.e. ‘Best’ had the least unknown individuals, ‘Worst’ had a small



Figure 3.4: Photograph of banteng showing scars in the ear and on the body which were used for identification purposes. An example identification of a mature banteng bull in Malua Forest Reserve in the Malaysian state of Sabah (Borneo) using scars on the body and tears in the ear circled in red. (© Danau Girang Field Centre/Sabah Wildlife Department: Penny Gardner)

proportion of unknown individuals and ‘Naïve’ contained all unknown individuals): 1) Best-case scenario (BCS): all individuals were identified and those classed as unidentified in the ‘Worst’ case scenario were assumed to be a recapture of the most closely-resembling individual and added to their capture frequency, 2) Worst-case scenario (WCS): individuals confidently identified and also individuals that were not confidently identified, which were assigned a capture frequency of one, and 3) Naïve case scenario (NCS): every observation was assumed to be a unique individual with a capture frequency of one. These were used to

test for differences between forests and sampling units (Table 3.1). All surveys were standardised to 87 nights, and rank capture frequencies were estimated for each forest using the capture histories. The observed population size for each identification scenario was calculated using incidence-based accumulation curves, which indicated the location of an asymptote when all individuals had been detected. Accumulation curves were created using the Vegan Community Ecology package (Oksanen et al., 2012) and SpecAccum (Kindt & Oksanen 2014) in RGui version 3.1.0 with ‘random’ permutations of the sampling units without replacement to find the best accumulative fit. Using the PoolAccum package and four common non-parametric estimators (Figure 3.5) I calculated expected population size (N_{est}) and the number of undetected individuals (f_0) that were not observed during the survey period.

Forest	Scenario	Sampling unit
Malua Forest Reserve	Best	Camera Traps
Malua Forest Reserve	Best	Survey Days
Malua Forest Reserve	Worst	Camera Traps
Malua Forest Reserve	Worst	Survey Days
Malua Forest Reserve	Naïve	Camera Traps
Malua Forest Reserve	Naïve	Survey Days
Tabin Wildlife Reserve	Best	Camera Traps
Tabin Wildlife Reserve	Best	Survey Days
Tabin Wildlife Reserve	Worst	Camera Traps
Tabin Wildlife Reserve	Worst	Survey Days
Tabin Wildlife Reserve	Naïve	Camera Traps
Tabin Wildlife Reserve	Naïve	Survey Days

Table 3.1: Different combinations of study sites (Forest), scenario (Best or Worst case scenario) and sampling unit used to test assumptions of accumulation curves. Scenarios were named from the perspective of identification success. Scenarios: Best: all individuals were identified and those classed as unidentified in Worst case scenario were assumed to be a recapture of the most closely-resembling individual and added to their capture frequency. Worst: individuals confidently identified and also individuals that were not confidently identified, which were assigned a capture frequency of one. Naïve: every observation was assumed to be a unique individual.

Estimator name	Equation
Chao1	$S_P = S_O + a1^2/(2*a2)$
First order Jackknife	$S_P = S_O + a1*(N-1)/N$
Second order Jackknife	$S_P = S_O + a1*(2*n-3)/n - a2*(n-2)^2/n/(n-1)$
Bootstrap	$S_P = S_O + \text{Sum} (1-p_i)^N$

Note: Theoretical assumptions included a closed community during the sampling period and sampling is 'with replacement' (individuals were recorded but not removed from the assemblage. S_P = extrapolated size, S_O = the observed number of individuals, $a1$ = the number of individuals observed once, $a2$ = the number of individuals observed more than once. p_i = the frequency of individual i , and N is the number of sites in the collection.

Figure 3.5: Four incidence-based non-parametric estimators used for estimating the population size. The incidence-based data comprised of photographic recaptures of individuals accumulated over the survey period using camera traps. The four non-parametric estimators were taken from O'Hara and Oksanen (2014).

The most efficient estimator was determined by the least deviation from the observed population size (N_{obs}) using the BCS, and used to estimate the accumulation in population size using increments in 10-day and 10-station intervals. To ascertain the number of additional sampling units required to meet the expected 95% and 99% of the true population size, forward extrapolation was conducted using the non-parametric Chao2 estimator, which is suitable for small-scale spatial aggregation of species occurrence and incidence-based data, and corrects for small sample size (Chao et al., 2009):

$$N_{est} = N_{obs} + \left(1 - \frac{1}{t}\right) + \left(\frac{a_1^2}{2a_2}\right)$$

Note: N_{est} = Estimated population size, N_{obs} = observed population size, t = number of sampling units, $a1$ = number of individuals with only one observation, $a2$ = number of individuals with more than one observation.

The number of additional sampling units (g) required to observe N_{est} was calculated from the probability that the next incidence represents a previously undetected individual in an additional sampling unit ($q0 = \frac{a_1}{T}$), where T represents the total number of incidences in t samples (see Chao et al., 2009). The additional survey effort required to observe 95% and 99% of the true population size Chao2 N_{est} was calculated in terms of the number of

additional camera traps and number of survey days. Finally, I estimated realistic minimum and maximum population sizes for each forest based on four categories of assumptions: 1) Observed: minimum and maximum population sizes were equal to the N_{obs} BCS and N_{obs} WCS, 2) Naïve (NCS): minimum population size for ‘Naïve’ was equal to the N_{obs} BCS however the maximum population size was equal to the N_{est} plus the estimated number of unobserved individuals (f_0), 3) estimated Chao1: minimum and maximum population sizes were equal to the N_{est} BCS and N_{est} WCS, and 4) Estimated chao2: minimum population size was equal to the N_{est} BCS whilst the maximum was equal to the N_{est} WCS plus f_0 .

3.4 Results

3.4.1 Detection success and sampling efficiency

Camera trap survey duration ranged between 29 to 175 nights per camera/grid/forest, with a total of 23,424 camera trap nights (all grid surveys combined) due to electronic failure and malfunction. Sign survey durations were longer and more consistent, and ranged between 89 to 175 nights with a total of 24,516 sign survey nights. A total of 213 sampling stations were used, with 39 in seasonal freshwater swamp and 192 in lowland dipterocarp forest. Station elevation ranged from zero to 405m above sea level (a.s.l), and percentage leaf canopy cover ranged from 25% to 99%. Banteng were recorded on six occasions using sign surveys, whereas camera traps recorded 29 events, with herd size ranging between 1-9 individuals equating to 99 (unidentified) individuals observed within five of the seven grids using camera traps; Tabin: grid 1 (22), grid 2 (0), grid 3 (3) and grid 4 (32), and Malua: grid 5 (27), grid 6 (0), and grid 7 (15).

Significantly more detections were recorded using camera traps ($X^2 = 20$, $p < 0.001$, model 1 Table 3.2 and OR = 1.80(-), $p < 0.001$, model 1, Table 3.3). Within-cluster correlation between the stations was low ($r^2 = 35\%$), indicating that banteng were not captured consecutively at neighbouring points in the grid, and the close proximity (500m) between the stations did not cause undue bias. Longer survey duration did not positively influence the detection success of sign surveys. A slight increase occurred in sign surveys at stations that were higher in elevation (OR = 0.99, $p < 0.05$, model 4, Table 3.3) and at stations where canopy cover was more dense (OR = 0.96, $p < 0.1$, model 4, Table 3.3). Habitat type did

Table 3.2: Analysis of variance (ANOVA) of the means for each of the four GEEGLM model terms and interactions, with the chi-squared test statistic (X^2), degrees of freedom (Df), significance value (ANOVA P value) and significance of the relationship: * <0.05, ** <0.01, *** <0.001= highly significant, N/A = no significance, ^R = Random term..

Model No.	Model description	Terms	X^2	Df	ANOVA P value	Significance
1	Banteng ~ Method + Grid ^R	Method	20	1	<0.001	***
2	Banteng ~ Method * Survey + Grid ^R	Method	20	1	<0.001	***
		Survey	1	1	N/A	N/A
		Method:Survey	0	1	N/A	N/A
3	Banteng ~ Method * Canopy + Method * Elevation + Method * Habitat + Grid ^R	Method	20	1	<0.001	***
		Canopy	12	1	<0.001	***
		Elevation	5	1	0.05	*
		Habitat	1	1	N/A	N/A
		Method:Canopy	1	1	N/A	N/A
		Method:Elevation	5	1	0.05	*
		Method:Habitat	0	1	N/A	N/A
4	Banteng ~ Method * Canopy + Method * Elevation + Grid ^R	Method	20	1	<0.001	***
		Canopy	12	1	<0.001	***
		Elevation	5	1	<0.05	*
		Method:Canopy	2	1	N/A	N/A
		Method:Elevation	5	1	<0.05	*

Table 3.3: Description of GEEGLM models transformed to the probability of Odds of Ratio (OR) estimates used to determine the detection efficiency of sign surveys and camera trap stations and the effect of environmental factors. The presence/absence of the target species (Banteng) explained by (~) the two survey methods (Method): sign surveys (Sign) and camera trap stations (Camera: used as intercept). Interactions (*) between covariates: survey duration (Survey), percentage leaf cover (Canopy), elevation in meters above sea level (Elevation), ^R = Random term. GEEGLM OR model estimates, with lower standard errors (OR Low Std. err.) and upper standard errors (OR Upp. Std. err.). Within cluster correlation was explained by the model (Correlation) and standard errors (\pm Std err.) and the significance of the relationship (P value) denoted by: N/A = no significance, ' = <0.1 marginally non-significant, * = <0.05, ** = <0.01, *** = <0.001 high significance.

Model No.	Model description	Term	OR Estimate	OR lower std err	OR upper std err	P value	Correlation \pm Std err. (%)
1	Banteng ~ Method + Grid ^R	MethodSign	0.16	0.11	0.24	***	35 \pm 0.39
2	Banteng ~ Method * Survey + Grid ^R	MethodSign	0.02	0.00	0.33	N/A	36 \pm 12
		Survey	1.08	1.05	1.11	**	
		MethodSign:Survey	1.02	0.99	1.04	N/A	
3	Banteng ~ Method * Canopy + Method * Elevation + Method * Habitat + Grid ^R	MethodSign	16.83	5.12	55.28	N/A	31 \pm 0.85
		Canopy	0.95	0.93	0.97	*	
		Elevation	0.99	0.98	1.00	N/A	
		HabitatSeasonal Swamp	0.49	0.25	0.97	N/A	
		MethodSign:Canopy	0.96	0.94	0.98	.	
		MethodSign:elevation	0.98	0.98	0.99	*	
		MethodSign:Habitat Swamp	0.58	0.19	1.74	N/A	
4	Banteng ~ Method * Canopy + Method * Elevation + Grid ^R	MethodSign	9.96	1.65	60.12	N/A	32 \pm 0.60
		Canopy	0.95	0.94	0.97	*	
		Elevation	0.99	0.99	1.00	N/A	
		MethodSign:Canopy	0.96	0.94	0.98	.	
		MethodSign:Elevation	0.99	0.98	0.99	*	

not influence detection success, and drop-removal of this term and its interaction with the survey method resulted in a final model (model 4, Table 3.3) with low correlation (32%).

3.4.2 Accumulated and extrapolated population estimates

A total of 34 profiles were created using unique markings. Ranked capture frequencies of individuals using the BCS and WCS in Malua and Tabin showed no indication of a sex-biased trap effect in either forest although I did not directly test this relationship.

When estimating the accumulation of banteng over sampling days, the accumulation of new individuals occurred primarily during the first 40 sampling days in Malua and Tabin using the BCS (Figure 3.6). After 80 days, accumulation of new individuals in both forests using the WCS was considered to be near an asymptote at which point the standard error bars began to decrease (Figure 3.7). Using camera traps, accumulation of new individuals was gradual across all 108 stations for both BCS and WCS in Malua (Figures 3.8 and 3.9). In Tabin, new individuals were accumulated quicker using fewer camera traps, approximately 60 stations.

Accumulation of banteng over time in MFR

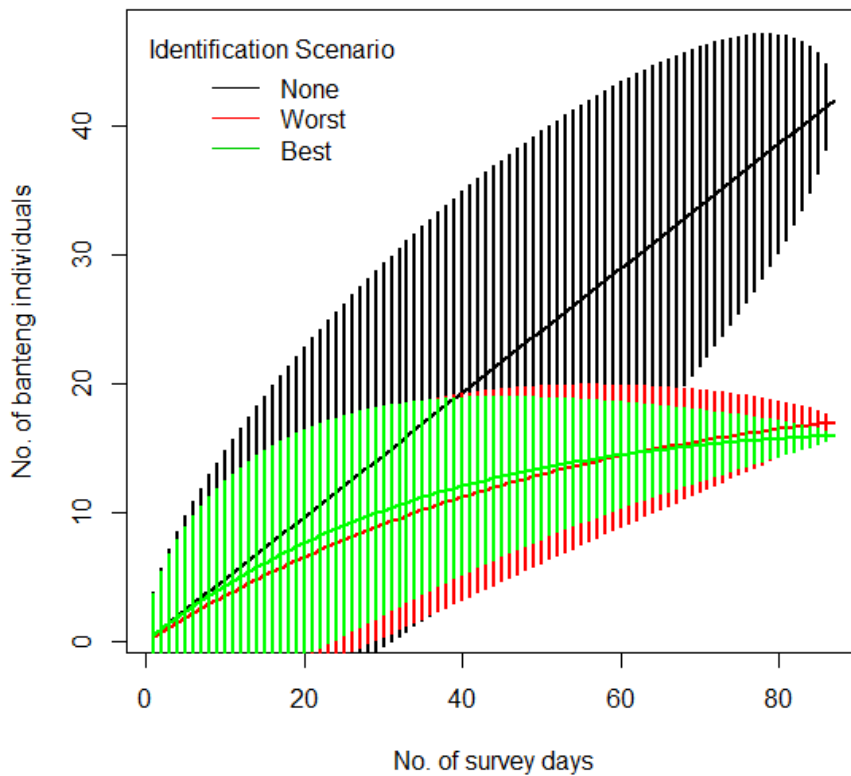

Figure 3.6: Accumulation curves of banteng over time (standardised 87 day survey across all grids) in Malua Forest Reserve (MFR) using random permutations of individuals without replacement identified according to a best case scenario (Best), a worst case scenario (Worst) and according to no identification of individuals (Naïve) with standard error bars. Note, the scale differences in the y-axis between forests due to a different number of individuals identified.

Accumulation of banteng over time in TWR

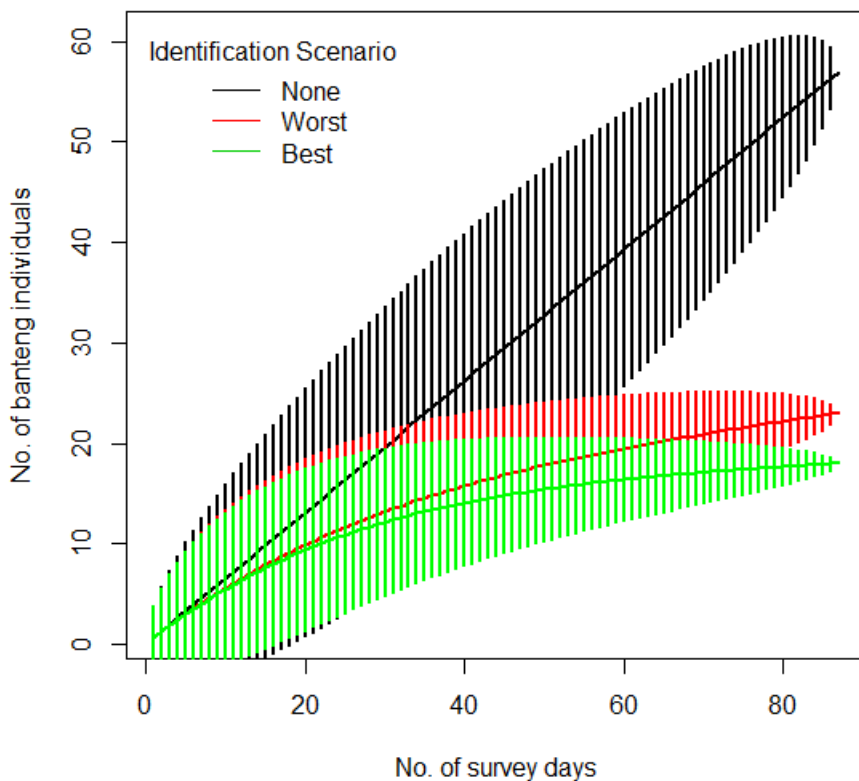

Figure 3.7: Accumulation curves of banteng over time (standardised 87 day survey across all grids) in Tabin Wildlife Reserve (TWR) using random permutations of individuals without replacement identified according to a best case scenario (Best), a worst case scenario (Worst) and according to no identification of individuals (Naïve) with standard error bars. Note, the scale differences in the y-axis between forests due to a different number of individuals identified.

Accumulation of banteng over stations in MFR

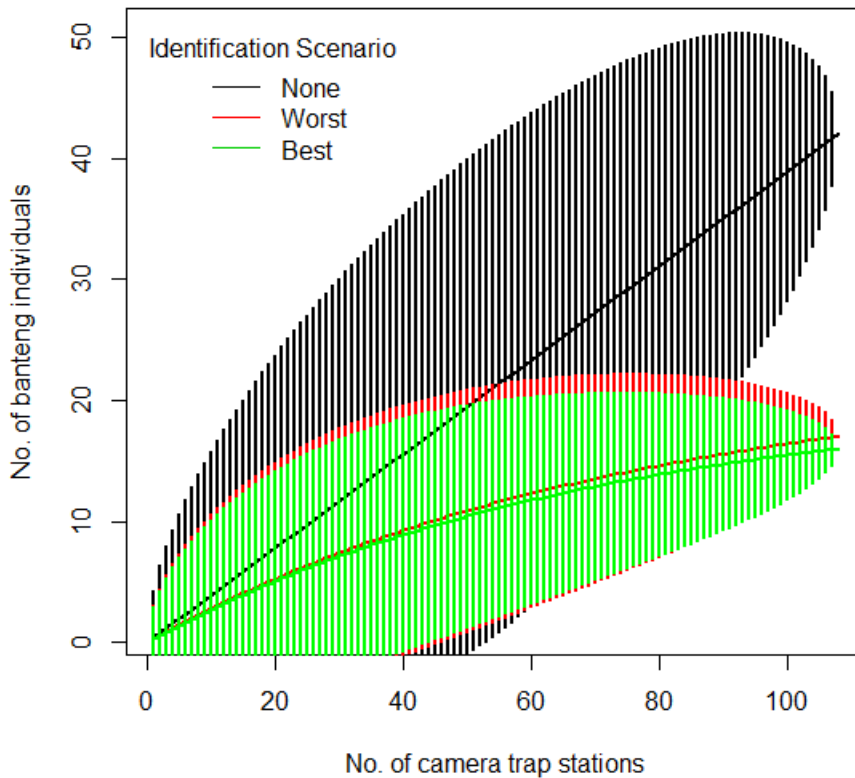

Figure 3.8: Accumulation curves of banteng across camera trap stations in Malua Forest Reserve (MFR) using random permutations of individuals without replacement identified according to a best case scenario (Best), a worst case scenario (Worst) and according to no identification of individuals (Naïve) with standard error bars. Note, the scale differences in the axes between forests due to a different number of camera trap stations used and number of individuals identified.

Accumulation of banteng over stations in TWR

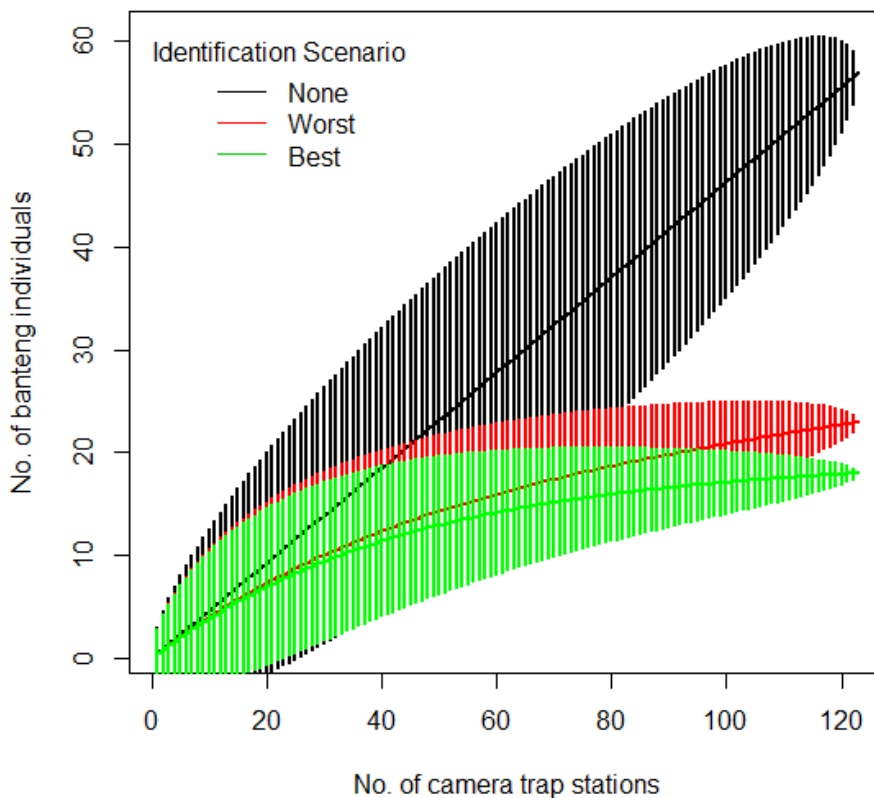

Figure 3.9: Accumulation curves of banteng across camera trap stations in Tabin Wildlife Reserve (TWR) using random permutations of individuals without replacement identified according to a best case scenario (Best), a worst case scenario (Worst) and according to no identification of individuals (Naïve) with standard error bars. Note, the scale differences in the axes between forests due to a different number of camera trap stations used and number of individuals identified.

Unidentified individuals resulted in a slight over-estimation of the extrapolated population size (Table 3.4). The best performing and most stable estimator was Chao1, which closely resembled the observed population sizes (N_{obs}). Overestimation using bootstrapping occurred in all identification scenarios. The least efficient estimators were the first and second-order Jackknife using the NCS which estimated 114 and 170 individuals in Malua and Tabin, respectively.

3.4.3 Incremental sampling

Using increments in survey days and the Chao1 estimator, 1 and 3 undetected banteng were estimated for Malua BCS and WCS, respectively, whilst 1 and 17 undetected banteng were estimated in Tabin BCS and WCS, respectively. All individuals in both forests were observed after 20 survey days (Table 3.5). Using increments in camera trap stations, 6 and 7, and 3 and 29 undetected individuals were estimated for Malua BCS and WCS, and Tabin BCS and WCS, respectively (Table 3.6). All individuals were observed in Malua using 20 stations and the BCS and WCS. In Tabin all individuals were also observed using 20 stations and the BCS, however 30 stations were required to observe all individuals when using the WCS.

Chao2 population size estimates were more conservative (Table 3.7) and were analogous with Chao1 when using complete identification (BCS), whereas partial-identification (WCS) resulted in a near two-fold increase in the total population estimate of Tabin. With no identification (NCS), extrapolation was twenty-times larger than the observed population sizes. The probability that the next incidence represented a previously undetected individual was consistently low across all forest and scenario combinations ($f_0 = < 0.17$) with the exception of the NCS. No additional sampling effort was required to observe 99% of the Chao2 estimated population sizes for Malua BCS. Approximately 40 additional camera traps or 32 survey days were required to observe 1 additional undetected individual using the WCS in Malua. In Tabin, approximately 38 additional camera traps or 27 survey days were required to observe 1 undetected individual using the BCS, and 126 camera traps or 89 survey days for 4 undetected individuals in Tabin using the WCS. Every individual represented a previously undetected individual using the NCS ($f_0 = 1$) therefore extrapolation resulted in exponential additional sampling effort and population estimates that were grossly overestimated.

Overall, it must be noted that Chao2 produced estimates of population size (N_{est}) for each forest/identification scenario that were remarkably similar despite the use of two very

different sampling methods to interpret the data, number of camera traps and the number of sampling days. These similarities may suggest that Chao2 is a reliable estimator given the observed data, and that either sampling method may give true estimates of the population sizes when identification variability is accounted for.

Table 3.4: The estimated population size using incidence-based data of banteng and four different estimators with associated standard errors (S.E): Chao1, Jackknife1 (Jack1), Jackknife2 (Jack2), bootstrapping (Boot) and the observed population size (N_{obs}) for each forest/scenario combination. The number of incidences (i.e. banteng captures) (T), the number of sampling units (i.e. the number of camera traps) (t).

Forest	Scenario	Sampling unit	T	t	N_{obs}	Chao	Chao S.E	Jack1	Jack1 S.E	Jack2	Boot	Boot S.E
Malua	Best	Survey days	42	87	16	16.9	1.46	18.96	1.71	17.07	18	2.12
	Worst	Survey days	42	87	17	19.57	2.81	22.93	3.12	22.03	20.28	2.87
	Naïve	Survey days	42	87	42	42	0	83.52	16.08	124.55	57.36	7.64
Tabin	Best	Survey days	57	87	18	20.67	3.48	21.95	3.14	22.96	20.07	2.06
	Worst	Survey days	57	87	23	39.67	14.84	32.88	5.06	39.76	27.31	2.74
	Naïve	Survey days	57	87	57	57	0	113.34	15.73	169.03	77.85	7.32
Malua	Best	Camera traps	42	108	16	22.13	6.08	22.93	6.93	25.92	19.3	3.81
	Worst	Camera traps	42	108	17	25	7.48	24.92	7.96	28.89	20.67	4.25
	Naïve	Camera traps	42	108	42	42	0	83.61	20.73	124.83	57.38	9.95
Tabin	Best	Camera traps	57	123	18	20	2.65	21.97	3.14	21.99	20.2	2.1
	Worst	Camera traps	57	123	23	53.25	28.64	33.91	4.97	42.78	27.57	2.72
	Naïve	Camera traps	57	123	57	57	0	113.54	15.32	169.61	77.88	7.19

Table 3.5: The observed population size (N_{obs}) and the estimated Chao1 population size (N_{est}) interpolated to 10-day intervals over the survey period (T) for three identification scenarios: Best (BCS), Worst (WCS) and Naïve: (NCS), and for both study sites: Malua Forest Reserve (top) and Tabin Wildlife Reserve (bottom).

Forest	Scenario	T	N_{obs}	Chao N_{est}	Chao S.E	10-day intervals																	
						10	Std Dev.	20	Std Dev.	30	Std Dev.	40	Std Dev.	50	Std Dev.	60	Std Dev.	70	Std Dev.	80	Std Dev.	(End) 87	Std Dev.
Malua	Best	87	16	17	1.46	4.3	4.9	11	13.9	19	21.5	23	23.1	24	19	21	11.4	20	10.4	18	3.1	17	0
	Worst	87	17	20	2.81	4.7	5.6	11	18.1	19	21.5	26	22.6	27	21.2	24	16.5	22	9.5	20	2.8	19.6	0
	Naïve	87	42	42	0	4.8	4.4	10	6.4	15	7.5	20	8.2	24	7.7	29	6.5	34	6.1	39	3.7	42	0
Tabin	Best	87	18	21	3.49	8.4	13.1	24	22.3	24	14.4	24	13.5	24	15.5	21	7.6	20	3.8	21	2.7	20.7	0
	Worst	87	23	40	14.84	11	15.5	27	24.9	32	23.5	31	18.8	33	18.1	35	18.7	35	13	37	8.8	39.7	0
	Naïve	87	57	57	0	6.6	5	13	6.2	19	7.1	26	6.7	34	5.9	41	6.6	47	5.8	54	3.5	57	0

Table 3.6: The observed population size (N_{obs}) and the estimated Chao1 population size (N_{est}) interpolated to 10-station intervals over the survey period (T) for three identification scenarios: Best (BCS), Worst (WCS) and Naïve (NCS), and for both study sites: Malua Forest Reserve (*top*) and Tabin Wildlife Reserve (*bottom*).

		<i>10-Station intervals</i>																													
Forest	Scenario	T	N_{obs}	N_{est}	Chao S.E	10	Std Dev.	20	Std Dev.	30	Std Dev.	40	Std Dev.	50	Std Dev.	60	Std Dev.	70	Std Dev.	80	Std Dev.	90	Std Dev.	100	Std Dev.	(End) 108	Std Dev.				
Malua	Best	108	16	22	6	4	6	10	15	18	25	27	34	27	25	26	24	25	18	25	17	24	13	22	5	22	0				
	Worst	108	17	25	7	5	17	14	28	22	31	28	32	24	23	27	26	26	22	29	25	26	19	26	12	25	0				
	Naïve	108	42	42	0	3	5	7	8	13	10	17	11	19	11	23	9	27	9	32	8	35	7	39	5	42	0				
		<i>10-Station intervals</i>																													
Forest	Scenario	T	N_{obs}	N_{est}	Chao S.E	10	Std Dev.	20	Std Dev.	30	Std Dev.	40	Std Dev.	50	Std Dev.	60	Std Dev.	70	Std Dev.	80	Std Dev.	90	Std Dev.	100	Std Dev.	110	Std Dev.	120	Std Dev.	(End) 123	Std Dev.
Tabin	Best	123	18	20	3	5	5	16	23	20	14	26	16	23	11	21	11	20	6	21	7	21	6	22	7	21	4	20	2	20	0
	Worst	123	23	53	29	4	4	15	15	25	26	31	25	32	23	29	14	33	17	34	16	38	14	42	17	45	14	52	9	53	0
	Naïve	123	57	57	0	4	4	9	6	14	7	18	7	24	7	28	7	33	7	37	7	41	6	47	5	51	4	56	2	57	0

Table 3.7: Chao2 estimation of population size (N_{est}) of banteng in Malua and Tabin using incidence-based data from both sampling units: Camera trap stations and survey days, and three identification scenarios: Best (BCS), Worst (WCS) and Naïve (NCS). The number of additional sampling units required to observe a target 95% (^{95}g) and 99% (^{99}g) of N_{est} were also calculated for both sampling units. T = number of observations of banteng, t = number of sampling units (camera trap stations or survey days), $a1$ = number of individuals observed once, $a2$ = number of individuals observed twice or more, N_{obs} = observed population size. $q0$ = the probability that the next incidence represents a previously undetected individual, $f0$ = the number of undetected individuals, $\phi = g$ must exceed 0.95 and $\dagger = g$ must exceed 0.99 due to the restriction $gN_{est} > S_{obs}$: see Chao et al (2009) for an extensive explanation on equations.

Forest	Scenario	Sampling unit	Sampling area (km ²)	T	t	a1	a2	N_{obs}	$q0$	$f0$	$^{95}N_{est}$	^{95}g	$^{99}N_{est}$	^{99}g	N_{est}
Malua	Best	CT station	27	42	108	3	13	16	0.07	0.34	15.2	0	15.84	0	16
	Worst	CT station	27	42	108	5	12	17	0.12	1.03	17.1	3.08	17.82	39.76	18
	Naïve	CT station	27	42	108	42	0	42	1	853.03	826.5	?	861.3	?	870
Tabin	Best	CT station	30.5	57	123	5	13	18	0.09	0.95	18.05	0.15	18.81	38.71	19
	Worst	CT station	30.5	57	123	10	13	23	0.17	3.81	25.65	49.59	26.73	125.91	27
	Naïve	CT station	30.5	57	123	57	0	57	1	1583.02	1558	?	1623.6	?	1640
Malua	Best	Survey day	27	42	87	3	13	16	0.07	0.34	15.2	0	15.84	0	16
	Worst	Survey day	27	42	87	5	12	17	0.12	1.03	17.1	2.45	17.82	32.08	18
	Naïve	Survey day	27	42	87	42	0	42	1	851.1	848.35	?	884.07	?	893
Tabin	Best	Survey day	30.5	57	87	5	13	18	0.09	0.95	18.05	0.05	18.81	27.47	19
	Worst	Survey day	30.5	57	87	10	13	23	0.17	3.8	25.65	35.01	26.73	89.05	27
	Naïve	Survey day	30.5	57	87	57	0	57	1	1577.65	1553.25	?	1618.65	?	1635

Table 3.8: The observed and estimated minimum and maximum population size estimates using the BCS (Min. Pop. Size^B) and WCS (Max. Pop. Size^W) within the survey areas of Malua Forest Reserve and Tabin Wildlife Reserve. The observed population size is reported before extrapolation (*) and the estimated population size after extrapolation and including undetected individuals (†).

Forest	Sampling area (km ²)	Observed*		Naïve* - †		Estimated ^{Chao1} †		Estimated ^{Chao2} †	
		Min. Pop. Size ^B	Max. Pop. Size ^W	Min. Pop. Size ^B	Max. Pop. Size ^W	Min. Pop. Size ^B	Max. Pop. Size ^W	Min. Pop. Size ^B	Max. Pop. Size ^W
Malua Forest Reserve	27	16	17	42	893	17	25	16	20
Tabin Wildlife Reserve	30.5	18	23	57	1640	20	53	19	27

Banteng were only present in two sampling grids in Malua (18km²) and three in Tabin (27.5km²) therefore I must stress that the population sizes reflect only these locations, not the entire forest reserve. The estimated population sizes were approximately one-third of the total number of photographic captures of banteng from each forest. Minimum and maximum population estimates (Table 3.8) ranged between 16-17 and 18-25 individuals in Malua, and 19-20 and 27-53 in Tabin. Extrapolation of raw frequencies of banteng captures indicated minimum and maximum estimates to be 42 and 893 in Malua, and 57 and 1640 in Tabin, respectively; these large estimates illustrate that incorrect application of extrapolation to raw frequencies results in a gross overestimation of population size that is unreliable. At present, the actual population size of banteng in Sabah is unknown. The two methods used here present the first population size estimates of banteng in two forests using quantitative methods, therefore there is no basis for comparison.

3.5 Discussion

3.5.1 Detection success and effectiveness of sampling

There is scarce information on the efficiency of survey methods for mammals inhabiting heterogeneous rainforest (Espartosa et al., 2011) and my results represent one of the first appraisals of two non-invasive techniques suitable for sampling large tropical forest mammals. My study is the first appraisal of survey methods suitable for banteng and my comparison permitted the estimation of environmental effects including elevation, habitat type and canopy cover upon detection efficiency. Overall, detection using camera traps was more consistent, whereas sign detection and longevity was highly variable depending on weather conditions and on the availability of adequate substrate (Espartosa et al., 2011). An open canopy resulted in sunspots, desiccation of the substrate and probably prevented track indentation. Conversely, gaps also directed intense rainfall causing waterlogging of the substrate and a reduction in sign longevity in open areas. Whilst sign detection was marginally lower in swamp habitat I found no evidence to support the hypothesis that sign detection was significantly negatively affected by swamp habitat. A positive increase in sign detection was found when canopy was more closed and at higher elevations, which contrasted with my two hypotheses suggesting the opposite to be true. It may be that a closed canopy preserves signs for a longer duration and increases the likelihood of detection. Furthermore, as forests at high elevations were difficult to log (until the recent development of alternative

methods) and were generally less damaged than lowland forest, their canopy cover may be denser, also promoting longevity of signs. Whilst it was not possible to draw analogies with the results of my banteng surveys and other survey techniques used in different studies due to a lack of research on this topic, I found consistencies with other studies which utilised a singular non-invasive sampling method to quantify other large mammals. A reduction in banteng detection using sign surveys was comparable with lower precision rates recorded when using dung detection of Asian elephant (*Elephas maximus*) (Hedges et al., 2013) and nest surveys of Western gorilla (*Gorilla gorilla*) (Arandjelovic et al., 2010) in comparison to DNA capture-recapture analysis. Rare species have lower encounter rates (Tobler et al., 2008) and require increased survey effort to obtain adequate precision (Walters 2010). A higher frequency of sign-surveys may have increased observations of tracks, particularly during the monsoon season when heavy rainfall causes soil erosion and flooding. However, increased human presence can negatively affect species presence (Walters 2010), and may actually decrease banteng presence.

3.5.2 Individual recognition and recapture history

Identification was time-consuming but permitted an evaluation on the effectiveness and suitability of a recapture framework for banteng, and allowed assessment of the accuracy of population size estimates, which is the first attempt for this species. I attempted to estimate population sizes and illustrate the degree of variability in population size estimates induced by identification heterogeneity at the study design level. This variability allowed us to determine realistic population sizes, and gauge the levels of inaccuracy by using estimates derived from raw frequency counts. The use of systematic uninterrupted sampling sessions of 87 days avoided excessive autocorrelation of sampling sessions but yielded sufficient data to conduct analyses, and has been identified as optimal for species that have low encounter rates (Tobler & Powell, 2013). When estimating additional survey effort I actually found my survey period to be super optimal but only when using complete identification. Over three-quarters of each forest (total) population could have been recognised using half the survey period. Potentially survey durations using identification could be reduced to a minimum of 40 days, as the majority of new individuals were captured during this time. The number of sampling units (camera stations) used in Tabin was also super optimal as, when confidently identified, the majority of new individuals were recognised using half the number of cameras. In Malua the number of camera stations was optimal, as accumulation of individuals was gradual and required all 108 units to capture all individuals.

My application of re-capture histories was not applied in the sense of a true recapture framework with stringent assumptions (e.g. developed for the program RMARK see Lake (2014)) however I believe that this is would be possible in the theoretical sense once information on breeding seasonality and ranging has been gathered. Attention must be drawn to the following points however. My preliminary analysis incurred violation of the ‘closed’ sampling season assumption, upon which traditional re-capture frameworks rely upon to obtain accurate estimates; during my study, emigration or immigration of individuals may have occurred due to the inability to account for the breeding season and due to the connectivity with forests surrounding Malua that were not surveyed. Despite this issue, I believe my sampling distances were independent and closure was partly achieved as no individual occurred within multiple grids. All captures throughout the standardised survey period were included in the analysis, as not taking re-captures into account would have resulted in a loss of information (Petit & Valiere 2006) and also reduced the ability to obtain accurate measures of accumulation. Unlike other large mammals such as felines, where photographic capture can be higher for sexes with large territories (Sollmann et al., 2013), I did not find evidence to suggest a sex-biased trap effect in banteng and, whilst females were difficult to identify, my results were not skewed towards males. If the banteng are a philopatric species and dispersal is sex-biased (e.g. male dispersal strategy as in many mammals) then it is possible that males will be recaptured more frequently but this would depend on the distribution of sampling units. If cameras were clustered in one home range area then it is probably that a high proportion of female captures would occur because they stay within the natal range. The presence of a sex-bias dispersal strategy in the banteng population could be explored in the future using molecular analysis and samples from Chapter 5.

3.5.3 Population size

I identified small accurate population sizes within the study areas of each forest with a small probability of additional undetected individuals, indicating my surveys to be near complete. These estimated population sizes were astonishingly similar despite the fact that two different methods and the number of sampling units (i.e. number of sampling days and number of camera trap nights) were used for modelling Chao2. Herd sizes were relatively small compared to one direct observation (18 individuals) and to other camera trap captures (16 individuals) not used in this chapter but included in Chapter 4. My results were consistent with average herd sizes in Java (Pudyatmoko & Djuwantoko. 2006) and Cambodia (Phan &

Gray 2010) but smaller than historic herd sizes in Thailand (25 individuals) (Bhumpakphan & Mcshea 2011). I found a patchy distribution of banteng herds across a forested landscape that was comparable in habitat type, with large tracts of remote dense lowland dipterocarp forest absent of banteng. For this reason upscaling population estimates on a linear scale with habitat size would be inappropriate.

3.5.4 Conservation and management

I advocate the use of camera traps over sign surveys for determining presence and monitoring of banteng, particularly as they are found in difficult terrain unsuitable for traditional survey methods. My methods could be applied to other forests to monitor the presence and longevity of specific individuals, particularly during human-driven disturbances such as timber harvesting. Identification of banteng presence can be used to inform anti-poaching patrols, create a conservation strategy to reduce future disturbance, and evaluate value of management practices such as nutrient supplementation/implementation of artificial salt licks. Methodology modifications to reduce financial expenditure but retain the accuracy of estimates would be required however; a shortened survey period and a strong emphasis on accurate identification. In order to conduct more common population estimation analyses, two issues must be resolved: 1) the attainment of more accurate dispersal distances and home range sizes in order to avoid autocorrelation in future sampling, and 2) basic information on the timing of reproduction to help resolve the issue of a closed sampling season. Preliminary observations on the latter were acquired from both forests, however this data was insufficient to conduct analysis. Despite these issues, this study highlights the potential to conduct population estimation on a cryptic species with individuals that are not outwardly unique (i.e. pelage patterning like the Sunda clouded leopard), and is a fundamental achievement in the acquisition of the first baseline data on the Bornean banteng. However, it also highlighted causes for concern over the longevity of this species. Where internal forest openings containing forage were not available or insufficient to support a herd, banteng were forced to travel regularly to the forest edge to forage on roadside verges. This amplified their vulnerability to hunting conducted along these roads and inside the forest fringe (Chapter 4), and the increased travel may also have diverted time and energy from other activities which can impact upon fitness, reproduction and immunity (e.g. Marchand et al., 2014). Banteng were found to occupy both protected and unprotected land due to be logged, however their presence and endangered status did not provide protection of the latter habitat to prevent conversion to plantation. If the small population of Bornean banteng are to be conserved in-

situ then occupied forest habitat should be retained, ideally with connectivity between occupied forest patches.

3.7 References

- Ancrenaz, M., Ambu, L., Sunjoto, I., Ahmad, E., Manokaran, K. & Lackman, I., 2010. Recent surveys in the forests of Ulu Segama Malua, Sabah, Malaysia, show that orang-utans (*P. p. morio*) can be maintained in slightly logged forests. *PLoS One*, 5(7), e11510.
- Arandjelovic, M., Head, J., Kühl, H., Boesch, C., Robbins, M.M., Maisels, F. & Vigilant, L., 2010. Effective non-invasive genetic monitoring of multiple wild western gorilla groups. *Biological Conservation*, 143(7), pp.1780–1791.
- Bailey, L.L., Hines, J.E., Nichols, J.D. & MacKenzie, D.I., 2007. Sampling design trade-offs in occupancy studies with imperfect detection: examples and software. *Ecological Applications*, 17(1), pp.281–90.
- Bhumpakphan, N. & McShea, W.J., 2011. Ecology of gaur and banteng in the seasonally dry Forests of Thailand. In W. J. Mc Shea, S. J. Davies, & N. Bhumpakphan, eds. *The Ecology and Conservation of Seasonally Dry Forests in Asia*. Lanham: Rowman & Littlefield, pp. 179–194.
- Brook, S.M., van Coeverden de Groot, P., Scott, C., Boag, P., Long, B., Ley, R.E., Reischer, G.H., Williams, A.C., Mahood, S.P., Hien, T.M., Polet, G., Cox, N. & Hai, B.T., 2012. Integrated and novel survey methods for rhinoceros populations confirm the extinction of *Rhinoceros sondaicus annamiticus* from Vietnam. *Biological Conservation*, 155, pp.59–67.
- Chao, A., Colwell, R.K., Lin, C. & Gotelli, N.J., 2009. Sufficient sampling for asymptotic minimum species richness estimators. *Ecology*, 90(4), pp.1125–1133.
- Davies, G. & Payne, J., 1982. *A faunal survey of Sabah*, World Wildlife Fund - Malaysia.
- Espartosa, K.D., Pinotti, B.T. & Pardini, R., 2011. Performance of camera trapping and track counts for surveying large mammals in rainforest remnants. *Biodiversity and Conservation*, 20(12), pp.2815–2829.
- Gopalaswamy, a. M., Karanth, K.U., Kumar, N.S. & Macdonald, D.W., 2012. Estimating tropical forest ungulate densities from sign surveys using abundance models of occupancy. *Animal Conservation*, 15(6), pp.669–679.
- Gray, T.N.E., 2012. Studying large mammals with imperfect detection: Status and habitat preferences of wild cattle and large carnivores in eastern Cambodia. *Biotropica*, 44(4), pp.531–536.
- Gray, T.N.E. & Phan, C., 2011. Habitat preferences and activity patterns of the larger mammal community in Phnom Prich Wildlife Sanctuary, Cambodia. *The Raffles Bulletin of Zoology*, 59(2), pp.311–318.
- Gray, T.N.E., Prum, S., Pin, C. & Phan, C., 2012. Distance sampling reveals Cambodia's eastern plains landscape supports the largest global population of the endangered banteng *Bos javanicus*. *Oryx*, 46(04), pp.563–566.

- Hájková, P., Zemanová, B., Roche, K. & Hájek, B., 2009. An evaluation of field and noninvasive genetic methods for estimating Eurasian otter population size. *Conservation Genetics*, 10(6), pp.1667–1681.
- Hedges, S.S., Johnson, A., Ahlering, M., Tyson, M. & Eggert, L.S., 2013. Accuracy, precision, and cost-effectiveness of conventional dung density and fecal DNA based survey methods to estimate Asian elephant (*Elephas maximus*) population size and structure. *Biological Conservation*, 159, pp.101–108.
- Kamler, J.F., Johnson, A., Vongkhamheng, C. & Bousa, A., 2012. The diet, prey selection, and activity of dholes (*Cuon alpinus*) in northern Laos. *Journal of Mammalogy*, 93(3), pp.627–633.
- Karanth, K.K., Nichols, J.D., Karanth, K.U., Hines, J.E. & Christensen, N.L., 2010. The shrinking ark: patterns of large mammal extinctions in India. *Proceedings of the Royal Society B: Biological sciences*, 277(1690), pp.1971–9.
- Karanth, K.U. & Nichols, J.D., 1998. Estimation of tiger densities in India using photographic captures and recaptures. *Ecology*, 79(8), pp.2852–2862.
- Kindt, R. & Oksanen, J., 2014. Species Accumulation Curves: SpecAccum. Available at: <http://cc.oulu.fi/~jarioksa/softhelp/vegan/html/specaccum.html>.
- Lake, J., 2014. Package “RMark.”, p.198. Available at: <http://www.phidot.org/software/mark/download/>
- De Luca, D.W. & Rovero, F., 2006. First records in Tanzania of the vulnerable Jackson’s mongoose *Bdeogale jacksoni* (Herpestidae). *Oryx*, 40(4), pp.468–471.
- Lyra-Jorge, M.C., Ciocheti, G., Pivello, V.R. & Meirelles, S.T., 2008. Comparing methods for sampling large-and medium-sized mammals: camera traps and track plots. *European Journal of Wildlife Research*, 54(4), pp.739–744.
- MacDonald, G., (2012). Leaf Cover Calculator. *In Prep*.
- Mackenzie, D.I., Nichols, J.D., Hines, J.E., Knutson, M.G. & Franklin, A.B., 2010. Estimating site occupancy, colonization, and local extinction when a species is detected imperfectly. *Ecology*, 84(8), pp.2200–2207.
- Mackenzie, D.I., Nichols, J.D., Lachman, G.B., Droege, S., Royle, A.J. & Langtimm, C.A., 2002. Estimating site occupancy rates when detection probabilities are less than one. *Ecology*, 83(8), pp.2248–2255.
- Mackenzie, D.I. & Royle, J.A., 2005. Designing occupancy studies: general advice and allocating survey effort. *Journal of Applied Ecology*, 42(6), pp.1105–1114.
- Marchand, P., Garel, M., Bourgoïn, G., Dubray, D., Maillard, D. & Loison, A., 2014. Impacts of tourism and hunting on a large herbivore’s spatio-temporal behavior in and around a French protected area. *Biological Conservation*, 177, pp.1–11.

- Melletti, M. & Burton, J. eds., 2014. *Ecology, Evolution And Behaviour of Wild Cattle: Implications For Conservation*, Cambridge: Cambridge University Press.
- Mondol, S., Ullas Karanth, K., Samba Kumar, N., Gopaldaswamy, A.M., Andheria, A. & Ramakrishnan, U., 2009. Evaluation of non-invasive genetic sampling methods for estimating tiger population size. *Biological Conservation*, 142(10), pp.2350–2360.
- O'Connell, A.F., Nichols, J.D. & Karanth, K.U., 2011. *Camera Traps in Animal Ecology: Methods and Analyses*, Tokyo: Springer.
- O'Hara, B. & Oksanen, J., 2014. Extrapolated species richness in a species pool. *R Documentation*. Available at: <http://cc.oulu.fi/~jarioksa/softhelp/vegan/html/specpool.html> [Accessed April 15, 2014].
- Oksanen, J.F., Blanchet, G., Kindt, R., Legendre, P., Minchin, P.R., O'Hara, R.B., Simpson, G.L., Solymos, P., Stevens, M. & Wagner, H., 2012. Vegan: Community ecology package. Available at: <http://cran.r-project.org/web/packages/vegan/index.html>.
- Pedersen, M.W. & Weng, K.C., 2013. Estimating individual animal movement from observation networks. *Methods in Ecology and Evolution*, 4(10), pp.920–929.
- Petit, E. & Valiere, N., 2006. Estimating population size with noninvasive capture-mark-recapture data. *Conservation Biology*, 20(4), pp.1062–1073.
- Phan, C. & Gray, T.N.E., 2010. Ecology and natural history of banteng in eastern Cambodia: evidence from camera trapping in Mondulkiri Protected Forest and Phnom Prich Wildlife Sanctuary. *Cambodian Journal of Natural History*, 2010(2), p.118.
- Pinard, M., Hewlett, B. & Davidson, D., 1996. Site conditions limit pioneer tree recruitment after logging of dipterocarp forests in Sabah, Malaysia. *Biotropica*, 28(1), pp.2–12.
- Pinna, M., Marini, G., Mancinelli, G. & Basset, A., 2014. Influence of sampling effort on ecological descriptors and indicators in perturbed and unperturbed conditions: A study case using benthic macroinvertebrates in Mediterranean transitional waters. *Ecological Indicators*, 37, pp.27–39.
- Portella, T.P., Bilski, D.R., Passos, F.C. & Pie, M.R., 2013. Assessing the efficacy of hair snares as a method for noninvasive sampling of Neotropical felids. *Zoologia*, 30(1), pp.49–54.
- Prayurasithi, T., 1997. *Ecology of banteng in Huai Kha Khaeng Wildlife Sanctuary*. Kasetsart University. Bangkok.
- Pudyatmoko, S. & Djuwantoko., 2006. Sex ratio, herd size and composition and sexual segregation in banteng in the Baluran National Park, Indonesia. *Journal of Biological Sciences*, 6(2), pp.370–374.
- Rönnegård, L., Sand, H., Andrén, H., Månsson, J. & Pehrson, Å., 2008. Evaluation of four methods used to estimate population density of moose *Alces alces*. *Wildlife Biology*, 14(3), pp.358–371.

- Rosellini, S., Osorio, E., Ruiz-González, A., Piñeiro, A. & Barja, I., 2008. Monitoring the small-scale distribution of sympatric European pine martens (*Martes martes*) and stone martens (*Martes foina*): a multievidence approach using faecal DNA analysis and camera-traps. *Wildlife Research*, 35(5), pp.434–440.
- Royle, J.A., Nichols, J.D. & Kery, M., 2005. Modelling occurrence and abundance of species when detection is imperfect. *Oikos*, 2(110), pp.353–359.
- Ruibal, M., Peakall, R., Claridge, A., Murray, A., & Firestone, K., 2010. Advancement to hair-sampling surveys of a medium-sized mammal: DNA-based individual identification and population estimation of a rare Australian marsupial, the spotted-tailed quoll (*Dasyurus maculatus*). *Wildlife Research*, 37(1), pp.27–38.
- Sabah Forestry Department, 2005. Class 7: Tabin Wildlife Reserve. Available at: [http://www.sabah.gov.my/htan_caims/Level 2 frame pgs/Class 7 Frames/tabin_fr.htm](http://www.sabah.gov.my/htan_caims/Level%20frame%20pgs/Class%207%20Frames/tabin_fr.htm) [Accessed May 7, 2009].
- Van Schaik, C.P., 1996. Activity periods of Indonesian rain forest mammals. *Biotropica*, 28(1), pp.105–112.
- Sollmann, R., Tôrres, N.M., Furtado, M.M., de Almeida Jácomo, A.T., Palomares, F., Roques, S. & Silveira, L., 2013. Combining camera-trapping and noninvasive genetic data in a spatial capture–recapture framework improves density estimates for the jaguar. *Biological Conservation*, 167, pp.242–247.
- Stanley, T.R. & Royle, J.A., 2005. Estimating site occupancy and abundance using indirect detection indices. *Journal of Wildlife Management*, 69(3), pp.874–883.
- Swan, M., Stefano, J., Christie, F., Steel, E. & York, A., 2014. Detecting mammals in heterogeneous landscapes: implications for biodiversity monitoring and management. *Biodiversity and Conservation*, 23(2), pp.343–355.
- Thomas, L., Buckland, S.T., Rexstad, E. a, Laake, J.L., Strindberg, S., Hedley, S.L., Bishop, J.R., Marques, T. a & Burnham, K.P., 2010. Distance software: design and analysis of distance sampling surveys for estimating population size. *The Journal of Applied Ecology*, 47(1), pp.5–14.
- Thorn, M., Scott, D.M., Green, M., Bateman, P.W. & Cameron, E.Z., 2009. Estimating brown hyaena occupancy using baited camera traps. *South African Journal of Wildlife Research*, 39(1), pp.1–10.
- Timmins, R.J., Duckworth, J.W., Hedges, S., Steinmetz, R. & Pattanavibool, A., 2008. *Bos javanicus*. In: IUCN 2012. IUCN Red List of threatened species. www.iucnredlist.org. Available at: www.iucnredlist.org/details/biblio/2888/0.
- Tobler, M.W., Carrillo-Percastegui, S.E., Leite Pitman, R., Mares, R. & Powell, G., 2008. An evaluation of camera traps for inventorying large- and medium-sized terrestrial rainforest mammals. *Animal Conservation*, 11(3), pp.169–178.

- Tobler, M.W., Carrillo-Percestequi, S.E. & Powell, G., 2009. Habitat use, activity patterns and use of mineral licks by five species of ungulate in south-eastern Peru. *Journal of Tropical Ecology*, 25(03), p.261.
- Tobler, M.W. & Powell, G.V.N., 2013. Estimating jaguar densities with camera traps: Problems with current designs and recommendations for future studies. *Biological Conservation*, 159, pp.109–118.
- Trolle, M., Noss, A.J., Cordeiro, J.L.P. & Oliveira, L.F.B., 2008. Brazilian tapir density in the Pantanal: A comparison of systematic camera-trapping and line-transect surveys. *Biotropica*, 40(2), pp.211–217.
- Vaughan, I.P., Noble, D.G. & Ormerod, S.J., 2007. Combining surveys of river habitats and river birds to appraise riverine hydromorphology. *Freshwater Biology*, 52(11), pp.2270–2284.
- Vine, S., Crowther, M., Lapidge, S., Dickman, C., Mooney, N., Piggott, M. & English, A., 2009. Comparison of methods to detect rare and cryptic species: A case study using the red fox (*Vulpes vulpes*). *Wildlife Research*, 36(5), pp.436–446.
- Walters, J., 2010. *Evaluating the suitability of wildlife monitoring methodology for tropical forest conservation a comparison of transect surveys and camera trapping*. MSc thesis, Imperial college London.
- Zero, V.H., Sundaresan, S.R., O'Brien, T.G. & Kinnaird, M.F., 2013. Monitoring an Endangered savannah ungulate, Grevy's zebra *Equus grevyi*: choosing a method for estimating population densities. *Oryx*, 47(03), pp.410–419.

Chapter 4: Activity budgets and thermal-regulation behaviour of the Bornean banteng (*Bos javanicus lowi*) in regenerating logged forests

4.1 Abstract

Key information on the activity patterns and habitat use of banteng are lacking but are essential to minimise further disturbance that may unduly stress this endangered bovid. Banteng habitat has suffered extensive degradation sustained from repeated logging since the 1960s, and this has reduced leaf cover and exposed soil. Consequently, recently logged forests may have a higher ambient temperature and be characterised by the growth of pioneer grasses and scrub. Logged forests are scarred with large canopy gaps interconnected by a network of abandoned logging roads, and these networks facilitate encroachment, causing wildlife conflicts. Extensive camera trapping was conducted in three secondary forests in Sabah to estimate the first activity patterns of the endangered Bornean banteng and to explore the expression of thermal-regulation behaviour mediated by post-logging regeneration age. I obtained the largest ever data set for the banteng, spanning >46,000 camera trap nights over six years (2008-2013). Activity in recently logged forest was bimodal whereby a lull occurred for 8hrs from late morning until late afternoon, whereas activity in old logged forest was consistent throughout the day. Activity was negatively related to temperature within all forests but was strongest in recently logged forest (r^2 : -0.68) where mean temperature exceeded 28°C for many hours, and weakest in very old logged forest (r^2 : -0.03) where mean temperature exceeded 28°C but only for 4 hrs. Energy-demanding activities (travel and foraging) in recently logged forest were conducted for long periods during cooler hours along old logging roads and in open areas, whereas resting was conducted under dense canopy during hot hours. Banteng in very old logged forest travelled throughout the day but switched to a closed canopy after sunrise. Encroachment by armed hunters seeking bush meat and/or sandalwood was frequently observed, particularly along old logging roads. Logging reduces leaf canopy cover, which essentially reflects heat and governs ambient temperatures, and also creates an extensive network of logging roads that facilitate unwanted human encroachment. Banteng expressed signs of thermo-stress and mitigated high temperatures by curtailing activity during hot hours, decreasing energetic activities, and by seeking refuge in dense canopy. As banteng forage for long periods along old logging roads they are vulnerable to being killed by hunters. Alternative measures of sustainable logging should take into account such wildlife behaviour and encroachment issues.

4.2 Introduction

The activity patterns of rare and shy large herbivores inhabiting tropical forests are little known and seldom studied (Gray & Phan 2011). The endangered Bornean banteng (*Bos javanicus lowi*) is rarely seen due to its shy nature and preference for remote habitat. They have not been extensively studied due to the complexities of gathering data on their behaviour without disturbing their natural habits. Studies conducted on Burma banteng in Cambodia (*Bos javanicus birmanicus*) and on Javan banteng in Java (*Bos javanicus javanicus*) identified their behaviour as distinctly nocturnal (Gray & Phan 2011; van Schaik 1996), particularly when subjected to human disturbance such as hunting activity (Gray & Phan 2011). When undisturbed, banteng in Java exhibit two to three hour periods of foraging alternating with periods of resting and ruminating (Timmins et al., 2008) not unlike the habits of domestic cattle which show clearly defined feeding periods followed by intervals during which they ruminate (Metz 1975). Preliminary observations of banteng suggest they become nocturnal when their habitat is disturbed by heavy vehicles (Payne et al., 1985) and, when logging activity commences, they retreat to undisturbed forest sometimes at higher elevations which are left unlogged due to the unfavourable slope (Timmins et al., 2008); P. Gardner, pers. obs.). These closed forests are a refuge from disturbances (Gray & Phan 2011).

The Bornean banteng is found in wildlife and forest reserves mainly in the east and central region of Sabah but also in isolated areas in the west (see Davies & Payne 1982), all of which have suffered degradation as a result of logging. Some forest reserves are licenced for commercial timber production (New Forests Ltd. 2008) whilst wildlife reserves are totally protected against logging. Timber extractions, and the presence and noise of heavy machinery are presumed to have adverse effects upon large-bodied mammals such as the banteng (Wong et al., 2013), at present though practically nothing is known about the extent of logging's impacts (Brodie et al., 2014; Sheil & Meijaard, 2008). Following the physical act of timber removal, secondary effects such as the change in the vegetation structure, composition and diversity, and the degree of change in the local climate upon the behaviour of banteng are also unknown but equally important for their survival. Herbivores of the lower canopy strata are thought to be more tolerant of logging than those that inhabit the upper layers of the canopy (Sheil & Meijaard 2008).

Banteng are an intermediate feeder (Timmins et al., 2008), and typically forage on herbaceous plants, soft vines, shrubs, young bamboo shoots and wild fruits such as Guava (P. Gardner, pers. obs.). Post-logging conditions such as an open canopy and disturbed soil provide favourable conditions for the growth of such pioneer species, and post-logging vegetation regeneration provides forage suitable for ungulates (Boan et al., 2011; Neumann et al., 2013).

Preliminary observation of banteng travelling and foraging within highly disturbed areas suggests they may indeed be a disturbance-tolerant species. The effects of timber removal are widespread however and other biotic and abiotic issues may confound the degree of tolerance exhibited in their behaviour. Temperature is one of the most important environmental variables governed by the tree stratum, and a reduction in tree density and continuous canopy cover directs sunlight to the forest floor and increases the ambient temperature (Bergstedt & Milberg 2001). In Sabah, the temperature within a severely logged forest (8 months prior) was 13.3°C higher than the daily average temperature within adjacent primary forest (Pinard et al., 1996). High temperatures can alter behaviour of mammals that have a high body index and large body mass, which results in high heat production and a lethal rise in core body temperature (e.g. Rowe et al., 2013). In extreme ambient air temperatures the regulation of activity is key to the dissipation of heat and maintaining fitness (Shrestha et al., 2014). Dissipation of body heat is conducted by means of wallowing and bathing, seeking refuge in shaded habitat and choosing a nocturnal habit when temperatures are cooler (Rowe et al., 2013; Shrestha et al., 2014; Allred et al., 2013). For some *Bos* species thermo-relief from a closed canopy has been identified as important (see Allred et al., 2013) because they have very narrow thermal niches (Shrestha et al., 2014). The moose (*Alces alces*) (van Beast et al., 2012), Cape, West and Central African buffalo (*Syncerus caffer*) and American bison (*Bison bison*) all practise behavioural thermo-regulation (Melletti & Burton 2014). This adjustment in activity has also been noted in wild and domesticated *Bos* species (Melletti & Burton 2014; Allred et al., 2013) and it would seem probable that the banteng would exhibit this too.

The act of logging and the removal of timber typically results in an extensive network of highly compacted gravel roads, skid-trails and badly damaged stumping grounds (also known as log-yarding areas) throughout the forest (Ancrenaz et al., 2010; Pinard et al., 1996). Stumping grounds are highly degraded from repetitive use by heavy vehicles and the damage sustained within these areas is so great that they remain prominent blots on the landscape, visible from air even years after logging activity has ceased, and require replanting in order to

be rehabilitated (Ancrenaz et al., 2010). When logging ends, old logging roads and access to internal open areas are sometimes barricaded with logs or basic gates, however this does not prevent encroachment by poachers. All ungulate species suffer from increased levels of hunting when forests are opened up by logging (Sheil & Meijaard 2008), and abandoned logging roads and skid trails are a precursor for this (Neumann et al., 2013; Gaveau et al., 2014). Open areas and abandoned logging roads carry an increased risk, and species which utilise them are more likely to encounter human-wildlife conflicts (Ancrenaz et al., 2014). Reports of poaching, particularly of banteng, are few. However, an absence of such reports does not mean that hunting activity is limited or that losses are not sustained.

Based on the success of camera traps for locating and studying banteng (Chapter 2), I continued to use them to conduct the first study on the activity patterns of the Bornean banteng. I quantified the diel activity of banteng in three forests to determine any differences in activity patterns associated with the different logging histories, and then examined the differences in temperature between forests to test whether my data supported the theory that reduced leaf cover results in higher ambient temperatures. I examined the activity budgets of three behaviour categories (travelling, grazing, and other: comprising resting, ruminating and fighting) in specific sites with different degrees of canopy cover to test the theory that a mammal with a large body mass may experience thermo-stress. I predicted that banteng would express thermo-stress by performing ‘other’ behaviour for longer periods in shaded areas during times of peak temperatures. Lastly, observations of illegal activity were compiled to assess the severity of disturbances and the overlap of habitat use which may result in a human-wildlife conflict.

4.3 Materials and Methods

4.3.1 Study Areas

Camera trap surveys were conducted from 2008-2013 in three protected forests within the east, central and south-central regions of Sabah, Malaysia Borneo (Figure 4.1). All camera traps were located in secondary forest within Malua Forest Reserve, Tabin Wildlife Reserve, and the buffer zones of Maliau Basin Conservation Area. The logging history and logging technique used within each forest varied accordingly: Malua Forest Reserve (5° N, 117° E) underwent extensive and repetitive timber harvesting from the 1960s up until the end of 2007

(Ancrenaz et al., 2010; New Forests Ltd., 2008) using a combination of conventional, traditional (crawler tractor), and reduced impact logging (RIL) techniques including heli-logging in higher elevations and also log-fisher logging. See Appendix 4.1 for a description of logging techniques. Much of Malua is heavily degraded and in the early stages of regeneration (New Forests Ltd. 2008). The buffer zones (1&2) of Maliau Basin Conservation

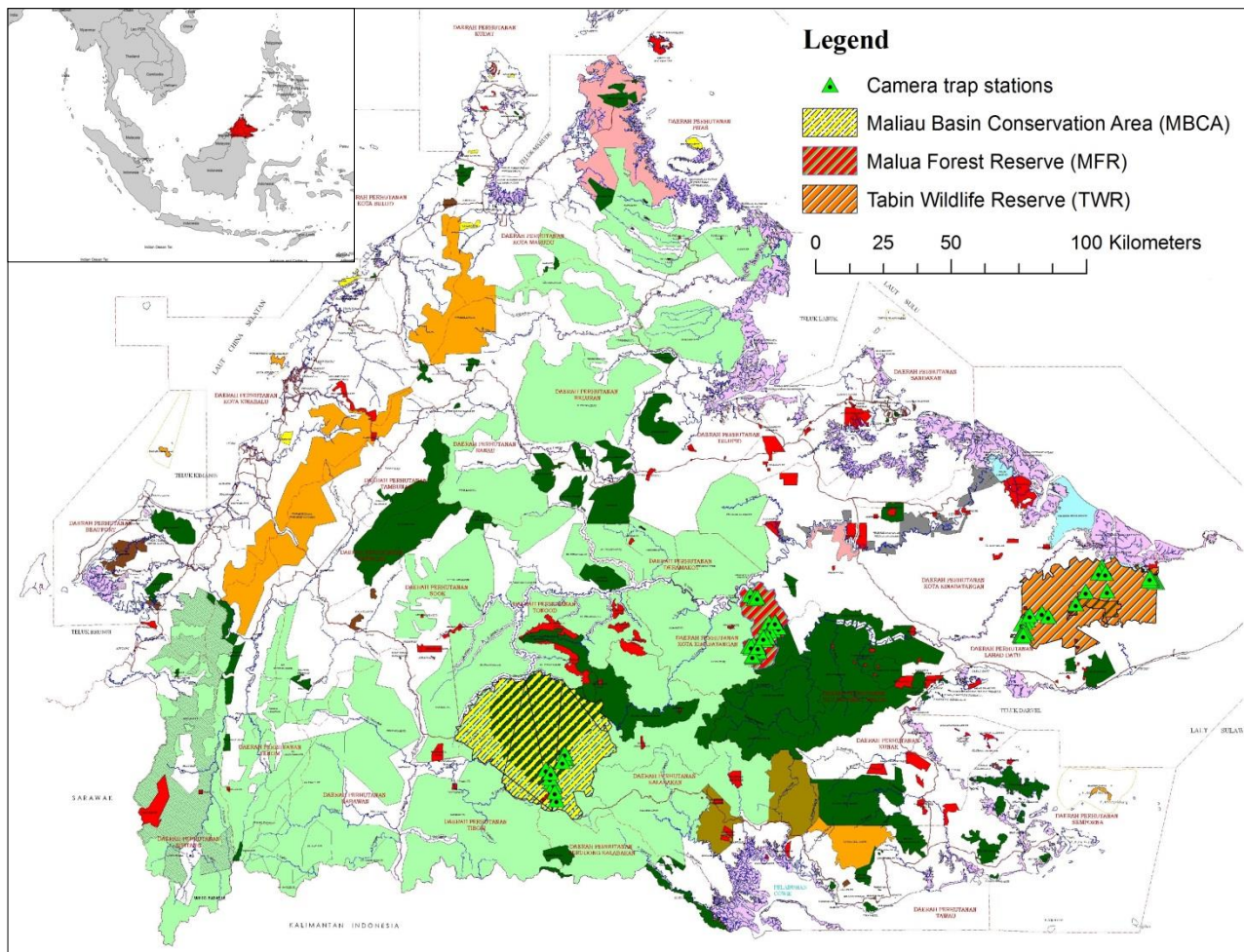

Figure 4.1: The location of Sabah (inset) on the island of Borneo, and the distribution of three forest reserves with different post-logging regeneration ages in the east (Tabin Wildlife Reserve (TWR): very old logged forest), central (Malua Forest Reserve (MFR): recently logged forest) and south-central (Maliau Basin Conservation Area (MBCA): old logged forest) regions of Sabah, Malaysia and the distribution of camera trap stations where banteng data was obtained. Note, other colours relate to forest classification designated by the Sabah Forestry Department: Virgin jungle reserve (red), protected forest reserve (dark green), commercial forest reserve (light green), Sabah parks (orange), wildlife reserve (light blue), mangrove forest reserve (pink), and amenity forest reserve (brown).

Area (4° N , 116° E) comprise secondary forest which was selectively logged in the early to mid-1990s (Brodie & Giordano, 2011), which (typically) removed only 4-10 stems per hectare and left the majority of the forest undisrupted (Gaveau et al., 2014). No further information is available on the logging history of Maliau and this is typical for much of Borneo, as confusion reigns over the true extent of deforestation for most of the island (Gaveau et al., 2014). Tabin Wildlife Reserve (5° N, 118° E) is the oldest post-logging regenerated forest of the three study sites. Tabin was extensively logged up until 1989 using conventional harvesting methods which created a vast network of skid trails (Sabah Forestry Department 2005). In areas that experienced very heavy logging and almost near-clear felling (e.g. hill sides in the west and in seasonal swamp forest within the east) there are little signs of successful regeneration and a starkly open canopy even after 25 years following the end of logging activity.

4.3.2 Field methods

Camera trap data was collated from a combination of studies targeting banteng and a range of other taxa (e.g. Sumatran rhino *Dicerorhinus sumatrensis* and all five species of Bornean wild felid). A total of 486 camera trap stations were deployed across the study sites (Table 4.1) along old logging roads, along wildlife trails with a closed canopy, and in open areas such as old stumping grounds (log preparation sites). As the survey focused upon activity budget rather than banteng occupancy, the criteria for station placement was different than in Chapter 3; images of banteng activity were required to obtain behavioural data therefore some stations were positioned where signs of banteng were found or expected, whilst other stations constituted a large grid formation (Chapter 3). Camera traps specifically for banteng and rhino were established at a height of 50-150cm due to their large body size, whereas cameras targeting wild felids ranged in height from 30-50cm; all were secured using a metal monopod in the ground or secured to trees or logs. Cameras were active over 24hrs and were triggered by a combination of heat and motion. For every trigger, three photographs were taken at one-second intervals. Camera trap models varied due to the preferences and budgets of each researcher, and it is possible that detection probability may have varied due to this factor. Models included were: the Snapshot Sniper P41 (Snapshot Sniper LLC, OK, USA), Cuddeback Capture (Non Typical Inc., WI, USA), Bushnell TrophyCam 2010 (Bushnell Corporation, KS, USA), Reconyx RM45, Reconyx HC500 & Reconyx PC800 HC500 (Reconyx Inc., WI, USA), and Panthera V3 (Panthera, New York, NY, USA). Only the Reconyx cameras had the function to record temperature; this camera trap model was used by

four out of five researchers therefore it was possible to obtain temperature with the majority of event data associated with banteng.

Table 4.1: Camera trap survey information and the number of banteng captures obtained from cameras set by the author during this study (☒) and from studies conducted by A. Hearn and J. Ross on wild felids (¥), J. Brodie on wild felids (‡), R. Bili on Sumatran rhino (†), and T. Bohm on Sumatran rhino (*) in three forests in Sabah.

Regeneration classification:	Recently logged	Old logged	Very old logged
Forest name	Malua Forest Reserve (MFR)	Maliau Basin Conservation Area (MBCA)	Tabin Wildlife Reserve (TWR)
Year logging ended	2007	1997	1989
Number of Stations ☒	145	16	130
Survey design	Grid & ad-hoc	Ad-hoc	Grid & ad-hoc
Target species	Banteng	Banteng	Banteng
Number of banteng captures ☒	282	10	27
Start of survey ☒	29/03/2011	24/05/2013	29/03/2011
End of survey ☒	19/10/2013	02/10/2013	18/10/2012
Number of CT nights ☒	13,552	884	13,979
Number of Stations ¥	38	N/A	75
Survey design	Ad-hoc	N/A	Ad-hoc
Target species	Wild felids	N/A	Wild felids
Number of banteng captures ¥	54	N/A	19
Start of survey ¥	11/07/2008	N/A	19/08/2009
End of survey ¥	11/02/2009	N/A	21/04/2010
Number of CT nights ¥	3,343	N/A	6,134
Number of Stations ‡	N/A	26	N/A
Survey design	N/A	Ad-hoc	N/A
Target species	N/A	Wild felid	N/A
Number of banteng captures ‡	N/A	13	N/A
Start of survey ‡	N/A	Jan-10	N/A
End of survey ‡	N/A	May-10	N/A
Number of CT nights ‡	N/A	2,915	N/A
Number of Stations †	10	N/A	N/A
Survey design	Ad-hoc	N/A	N/A
Target species	Sumatran rhino	N/A	N/A
Number of banteng captures †	51	N/A	N/A
Start of survey †	24/10/2009	N/A	N/A
End of survey †	24/07/2012	N/A	N/A
Number of CT nights †	2,034	N/A	N/A
Number of Stations *	N/A	N/A	46
Survey design	N/A	N/A	Ad-hoc
Target species	N/A	N/A	Sumatran rhino
Number of banteng captures *	N/A	N/A	8
Start of survey *	N/A	N/A	18/07/2012
End of survey *	N/A	N/A	16/02/2013
Number of CT nights *	N/A	N/A	4161
Number of Stations	N/A	N/A	46

Checks of the camera traps were conducted at least once a month to replenish batteries, digital storage cards, silica and to check the functionality of the camera traps.

Camera trap captures were assumed to correlate with true banteng activity patterns (Gray & Phan 2011) and autocorrelation was minimised in the study design and during data preparation using similar protocols to prior studies: independence of camera trap events/data was defined geographically and chronologically; a minimum distance of 100m was maintained between camera trap stations, and multiple events per station were discounted if they occurred within the same hour (Ramesh et al., 2012; Ross et al., 2013; Wearn et al., 2013). Where possible, all individuals were identified using a combination of scars and horn morphology (as detailed in Chapter 3), and multiple events of the same individuals during the same hour were discounted even if arising from different stations to minimise pseudo-replication (Bernard et al., 2013; Lafleur et al., 2013).

4.3.3 Statistical analysis

The data analysis comprised two parts: i) an overview of the time series activity/temperature data over 24 hours, and ii) an investigation into how hour/temperature affected the likelihood of different activities expressed by banteng and variation in site use. Acquiring data on banteng together with analysing datasets characterised by missing values and autocorrelation is exceptionally challenging (Sollmann et al., 2013), hence the use of a two-part strategy of descriptive statistics and bootstrapping of the time series using all data. Ambient temperature acquired from Reconyx camera traps provided a simple way to characterise preliminary hourly fluctuations at each site feature (e.g. logging road, and open and closed canopy). Whilst more sophisticated methods have been used to measure temperature for other behavioural studies, such as meteorological stations (Cruz et al., 2014; Lafleur et al., 2013; Oliveira-Santos et al., 2010; Thorn et al., 2009), a data logger (Fan et al., 2012), GPS collars fitted to individuals (van Beast et al., 2012), or handheld thermometers used during direct observations (Kosheleff & Anderson 2009) these were not possible for this study. Furthermore site-specific temperature fluctuations would not have been illustrated by the nearest meteorological station (> 20km away), located in primary forest with a continuous leaf cover that may result in much lower temperatures.

Diel activity and temperature

Bootstrapping is common practice in wildlife activity studies and is useful because datasets are generally small and autocorrelated (Ross et al., 2013; Wearn et al., 2013; Cragie et al., 2010; Christiansen et al., 2013). Furthermore, a simulated bootstrap dataset allows the estimation of robust and precise parameters (confidence intervals) otherwise not obtainable when data is limited and porous (Lynam et al., 2013). Here bootstrapping was used to estimate non-parametric 95% confidence limits around behaviour and temperature time series (Buckland, 1984; Fewster et al., 2000). Time series for banteng activity and temperatures were prepared by aggregating all available captures and associated temperatures into one dataset which included forests (MFR, MBCA and TWR), two-month intervals (e.g. Jun-Jul), season (wet and dry), and two-hour intervals (e.g. 00:01-02:00 hours) as explanatory variables.

Aggregating the data within two-month and two-hour intervals provided the best compromise between temporal detail (i.e. the number of two-hour periods with banteng recorded) and degree of replication. Very little is known of the seasonal effect upon behaviour (i.e. annual variation in diet composition leading to changes in foraging strategies) (Timmins et al., 2008) therefore season was initially investigated. A preliminary analysis indicated that there was no difference in timing of activity between wet (October-March) and dry (April-September) season therefore season was not included thereafter. Time series models were bootstrapped following the approach of Fewster et al., (2000). In the first stage, generalised linear models (GLMs) were fitted in R Gui 3.1.0 to relate activity or temperature to forest and hour, with an interaction between forest and hour to allow differences in daily activity among forests to be identified. A GLM with Gaussian errors and an identity link was used for temperature data whilst activity used a Poisson error distribution, and model fit was checked using plots of the residuals along with measuring over-dispersion. Fewster et al., (2000) identified 399 bootstraps as being likely to be adequate to obtain 95% confidence intervals in most applications, therefore 400 bootstraps were generated by stratifying upon forest, selecting two-month time series with replacement from each forest (Fewster et al., 2000). The GLMs were fitted and bootstrapped dataset and predictions generated. Using 400 iterations, 2.5 and 97.5 quantiles were calculated to obtain non-parametric 95% confidence intervals around the mean (Buckland 1984; Fewster et al., 2000). Significance testing was not conducted due to the issue of non-independent observations and the risk of drawing incorrect biological inferences. Stratification of mean diel hourly activity of banteng was comparable to studies of

tropical forest ungulates (by Tobler et al., 2009) including banteng in Cambodia (see Gray & Phan 2011), and felines (Azlan & Sharma 2006). Whilst I did not attempt to identify differences in activity according to sex or age categories like Ross et al., (2013) there remains considerable potential for exploring this avenue.

A relationship between leaf canopy cover and ambient temperature was identified in Sabah by Pinard et al., (1996). With this in mind, I expected higher mean temperatures within a recently logged forest, because large canopy gaps are still evident and regeneration is in the early stages, and the coolest temperatures within a very old logged forest, whereby growth over the past three decades should have resulted in advanced structural regeneration in degraded areas. I did not account directly for the method of logging (e.g. RIL) used in each forest due to the difficulty in obtaining information on each forests' logging history.

To accurately model temperature fluctuations at least one observation per hour/temperature in each forest was required for bootstrapping; without this information the model failed to produce an accurate estimate representing true hourly ambient temperatures. There were absences in hour/temperature data for forest MBCA at hour 4 (Feb.Mar) and hour 7 (Feb.Mar) therefore two observations were manually calculated using the average of the previous and subsequent hour/temperature (Zeileis et al., 2014). Unlike other studies which have explored the effect of temperature upon behaviour (see Giné et al., 2012; Kuo & Lee, 2012) I did not test for a significant relationship due to the inherent auto-correlated nature of the data. Instead, the correlation coefficient (r) between activity and the overall mean temperature of each forest was estimated to explore the direction of the relationship.

Activity budgets

Within each forest, the dataset was further stratified into activity budgets (i.e. the duration of time in minutes spent performing the following three categories of behaviour: 1) grazing, 2) travelling and 3) other: resting, ruminating and fighting. And lastly, according to three site features: 1) open canopy, 2) closed canopy or forest trail, and 3) logging road. Differences in the duration (in minutes) of activity budgets within each forest were estimated for each behavioural category expressed at each site feature. I adopted a similar procedure to that of Owen-Smith and Goodall (2010) but with more simplified behavioural categories. The addition of site categories similar to those used by van Beest et al., (2012) due to the level of thermal cover they may provide (i.e. mature forest, open mixed forest, and other (non-forest, agricultural land and open water) was deemed highly appropriate due to the extensive

modification of forest in Sabah and the unknown effects of logging practices upon wildlife behaviour. I simulated the occurrence and duration of each activity budget at each hourly interval using the bootstrapping method described above to determine if logging regeneration time and temperature influenced the duration of behaviour and the type of behaviour expressed.

4.3.4 Evidence of illegal activity

Lastly, the frequency and nature of illegal activities within each study site were estimated from a) camera trap captures, b) evidence of illegal activity (e.g. shotgun cartridges), c) direct observations, and d) reports from government staff. I present this information without analyses on the basis that there have been few documented accounts of illegal activity within protected forest reserves in Sabah, and to draw attention to this widespread activity which potentially influences analysis of behavioural data arising from camera traps.

4.4 Results

A total of 490 images of banteng were captured over a survey period of 46,892 nights. However, 23 were excluded for violation of independence. For analyses, 467 captures were included. Capture frequencies varied according to forest, and disproportionate sampling effort arose from pooling capture data from multiple researchers. Despite aggregation, the dataset remained highly sparse with absences in activity that may have be due to sampling design issues, imperfect detection or an unavailability of banteng, to name a few.

4.4.1 Activity patterns

The activity patterns of banteng in three forests differed in the occurrence and timing of activity peaks (Figure 4.2). Within the recently logged forest (MFR) activity was multimodal with two peaks during the crepuscular period when temperatures were cool; the largest peak occurred over dawn when temperatures were lowest and the second over dusk with a pronounced and drawn-out lull during the middle of the day when temperatures reached extreme high (33°C). Activity within the old logged forest (MBCA) fluctuated considerably but activity also curtailed during midday hours when temperatures were hottest. A strong peak in activity occurred during the late evening (20:01-22:00 hours) when temperatures had cooled. Activity within the very old logged forest (TWR) showed a pronounced dip early morning (02:01-04:00 hours) before a strong peak in activity over the dawn period. Activity

was elevated during the late morning and midday hours when temperatures were hot, although this period was not as hot as the midday temperatures within recently logged forest. However, unlike the other recently logged forests, the bantengs' activity in the very old logged forest (TWR) continued throughout the remainder of the day and night.

4.4.2 Ambient forest temperatures

Differences in mean hourly temperatures of all sites were evident between forests with different post-logging regeneration ages and I found strong evidence to suggest ambient temperature increases when leaf cover is reduced (Figure 4.3). Forest that was most recently logged (MFR) with approximately 7 years regeneration time and the least continuous canopy cover was, on average, the hottest forest, exhibiting a prolonged high which began mid-morning and continued to increase up to at least 32°C at 14:01-16:00 hours. Open canopy sites with considerably less leaf cover experienced extremes temperatures (36°C) during the same hour. Mean temperatures within the old logged forest (MBCA) that had >15 years of regeneration time reached a comparable overall mean temperature and open canopy temperature peak of 33°C. However, high temperatures were not sustained for long periods unlike in the recently logged forest (MFR). A long regeneration time of over 25 years within the very old logged forest (TWR) gave rise to the lowest average hourly temperatures of all three forests, with a daily average peak of 31.5°C experienced between 14:01-16:00 hours. Temperature within open canopy sites were elevated by 1.5°C and a high of 33°C occurred earlier, between 12:01-14:00 hours. Overall, the largest fluctuations in temperature were experienced in the very old logged forest (TWR: 15°C) where temperatures soared from 18°C to 33°C throughout the day, followed by the old logged forest (13°C: from 19°C to 33°C). The least fluctuation occurred in the recently logged forest (11°C) where temperatures were consistently above 22.5°C.

Correlations between bootstrapped hourly activity and temperature of each forest revealed a strongly negative relationship in the recently logged forest (MFR) whereby activity decreased with an increase in temperature (r : -0.68), a less pronounced negative relationship between activity and temperature in the old logged forest (MBCA) (r : -0.28) and a weak negative relationship between activity and temperature in the very old logged forest (TWR) (r : -0.03)

Overall, my results identified a very strong relationship between the age of logging and the ambient temperature of the forest that ultimately governs the timing of banteng behaviour. Due to a comparable habitat type and no biological differences in the banteng present in the

three forests, logging is clearly the central cause and the damage it causes has far-reaching repercussions which are evident for many years following the act of logging. These unseen consequences have not been widely documented for either traditional or RIL methods, and such measures of forest ecosystem sustainability (i.e. temperature and animal behaviour) are not part of the RIL philosophy. The severe alterations in the forest environment and banteng behaviour may suggest that RIL may not actually be sustainable for large animal populations, and the example of the banteng may provide an indication of what may be experienced by other large mammals within disturbed and degraded habitat in Sabah.

4.4.3 Activity budgets of specific behaviours

Segregation of activity into three categories and the duration of expression at each hourly interval revealed different emphasis on behaviours (e.g. more time spent foraging in recently logged forest (MFR) than in old logged forest (TWR)) within each forest, which corresponded strongly with temperature fluctuations (Figure 4.4). Energy-demanding activities such as travelling and grazing were generally conducted at hours avoiding peak temperatures, therefore suggesting banteng experience thermal-stress and try to mitigate the heat by adjusting specific behaviours. A large proportion of time was devoted to grazing within the recently logged forest (MFR) and occurred throughout all hours except during peak temperatures which occurred for an eight hour period (e.g. 08:01-16:00 hours). The proportion of time spent travelling was relatively less and generally occurred during the morning and evening hours. Less energetic behaviour (resting, ruminating and fighting) were primarily expressed during the morning hours when temperatures were still cool (e.g. 06:01-08:00 hours) and in the early afternoon (e.g. 12:01-14:00 hours) when temperatures peaked. Activity budgets within the old logged forest (MBCA) showed a large proportion of time was devoted to travel during the evening and night (e.g. 18:01-00:00 hours), and also to grazing which was conducted for longer periods during the late morning and late afternoon/evening despite high ambient temperatures. No resting, ruminating or fighting behaviour was observed, and activity during the middle of the day was confined to very short periods (<2 minutes) of travelling. Within the very old logged (TWR) the majority of activity comprised travelling at nearly all hours of the day, including hours categorised by high temperatures. Grazing was performed for relatively shorter periods primarily in the morning over dawn, late morning and late afternoon. The expression of other behaviour was confined to the evening after sundown.

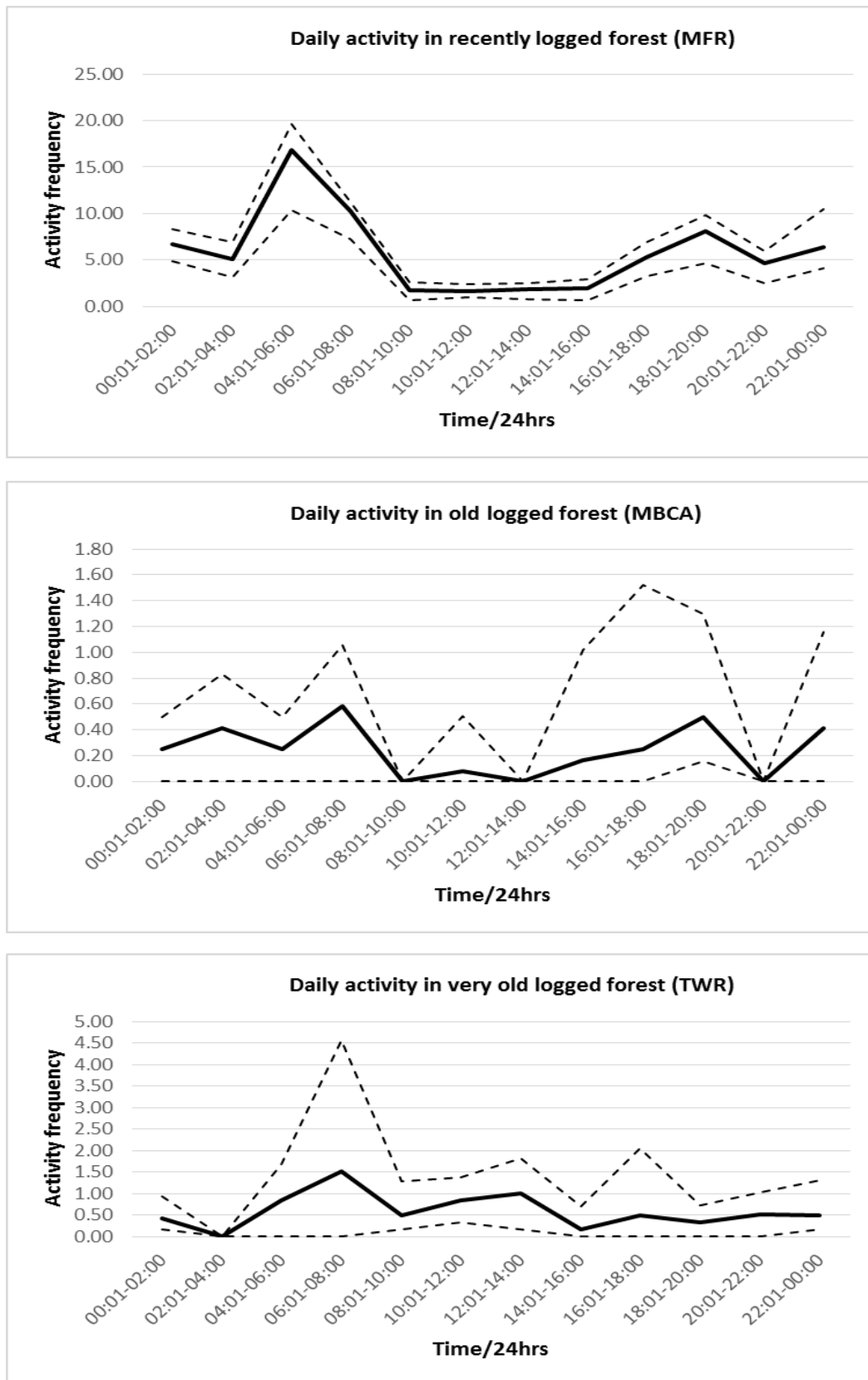

Figure 4.2: Observed frequency of activity patterns (i.e. the number of photographic captures of banteng) from camera trap event data over 24 hours in three forests with different post-logging regeneration times: recently logged forest (MFR: top), within an old logged forest (MBCA: middle), and within a very old logged forest (TWR: bottom), with non-parametric upper and lower 95% confidence intervals estimated from 2.5 and 97.5 percentiles using 400 bootstraps and a Gamma error distribution.

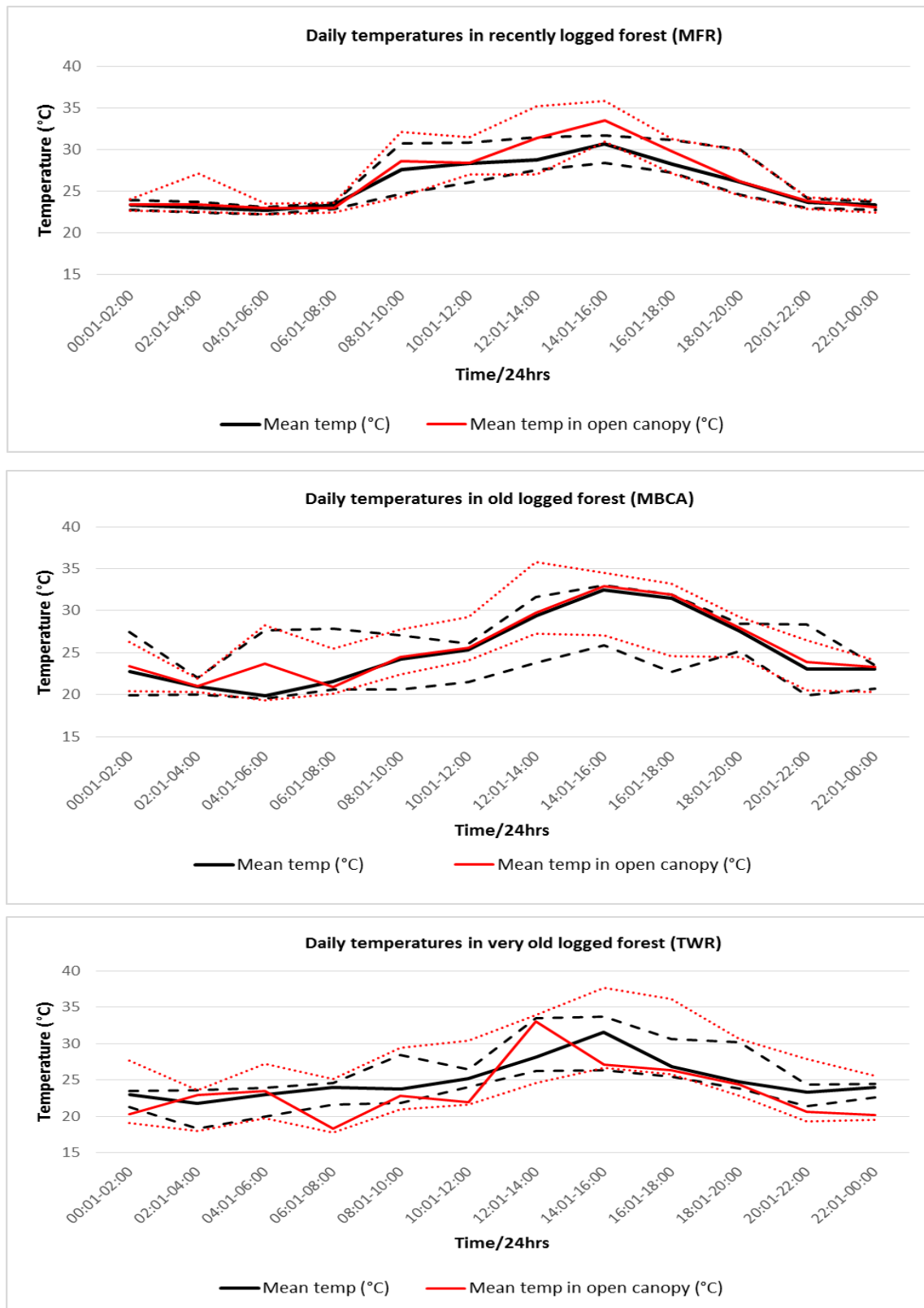

Figure 4.3: Observed mean temperature (all sites) and temperature in open canopy stations from camera trap event data over 24 hours in three forests with different post-logging regeneration times: recently logged forest (MFR: top), within an old logged forest (MBCA: middle), and within a very old logged forest (TWR: bottom), with non-parametric upper and lower 95% confidence intervals estimated from 2.5 and 97.5 percentiles using 400 bootstrap and a Gamma error distribution.

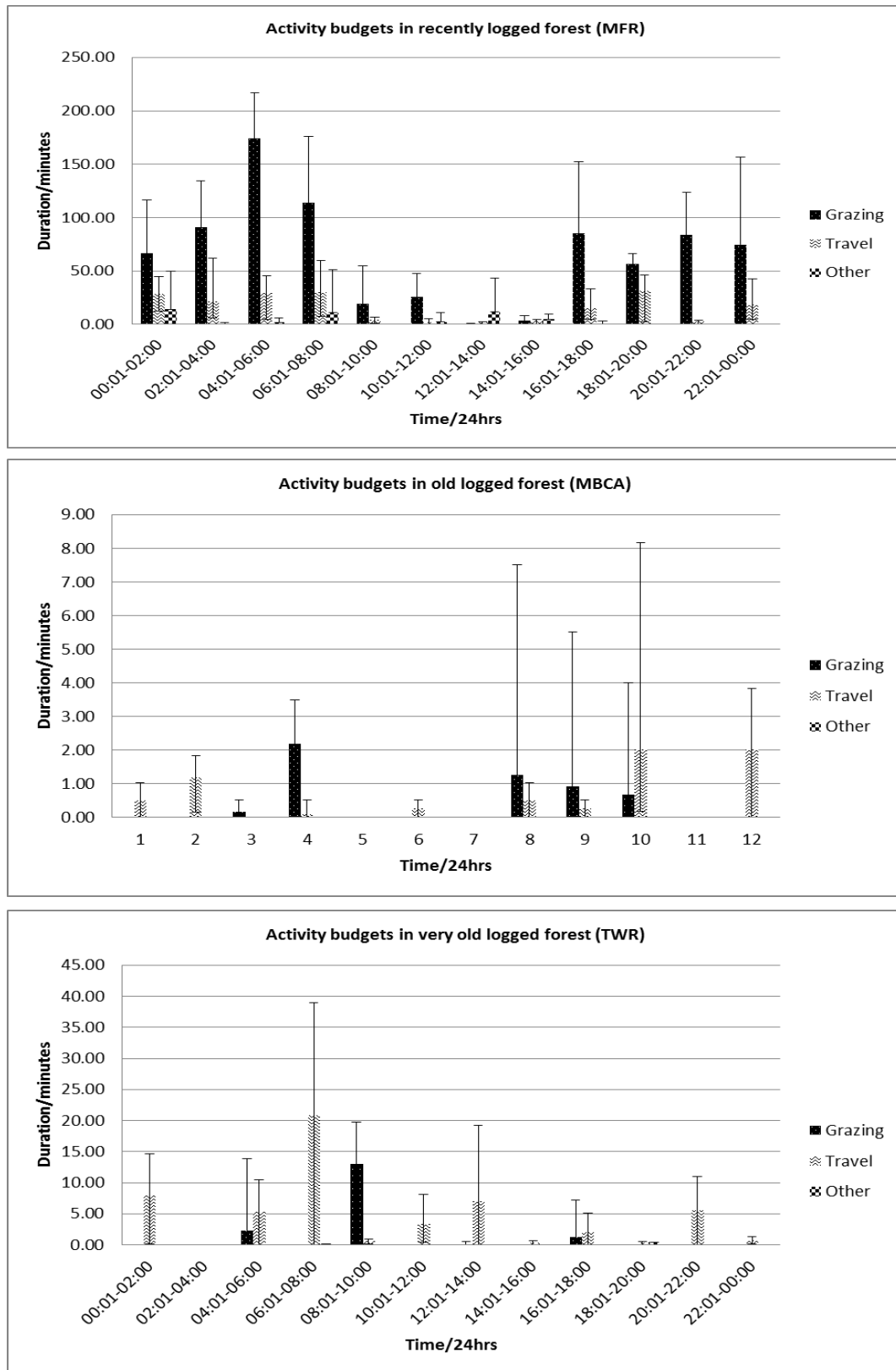

Figure 4.4: Mean duration of three activity budgets over 24 hours in three forests with different post-logging regeneration times: in a recently logged forest (MFR: *top*), within an old logged forest (MBCA: *middle*), and within a very old logged forest (TWR: *bottom*), with bootstrapped 95% confidence intervals estimated from bootstrapping with 400 iterations using a poisson error distribution. Note: Due to variation in the number of captures within each forest there are large changes in the y-axis scale.

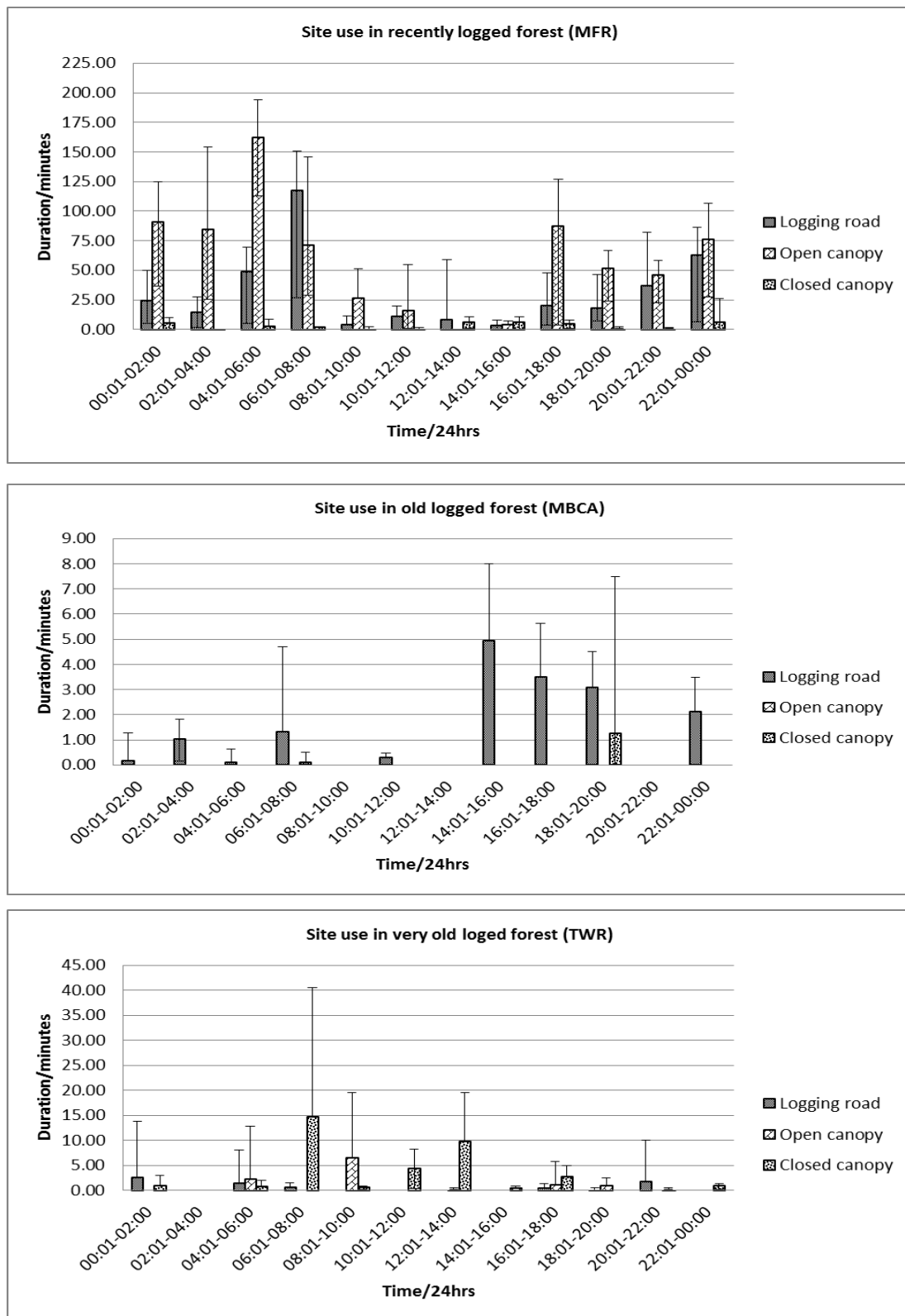

Figure 4.5: Observed durations of activity budgets (in minutes) in three different site features (abandoned logging roads, open canopy and closed canopy) in three forests with different post-logging regeneration ages with 95% confidence intervals expressed in three site features predominant within recently logged forest (MFR: *top*), old logged forest (MBCA: *middle*) and a very old logged forest (TWR: *bottom*). Note: Due to variation in the number of captures within each forest there are large changes in the y-axis scale.

4.4.4 Observations of human-driven disturbances

I found illegal activity to be widespread and diverse in nature across all forests (Appendix 4.2). Within the recently logged forest (MFR) evidence was frequently collected (23 documented events) not including 11 camera trap units which were stolen by hunters during my surveys; armed hunters caught on camera (7), sandalwood collectors (1), shotgun shells (5), part of an animal trap (1), hunter tracks (2), sack used for carrying meat (1), hunter resting spot and rubbish dump (1), gunshot sounds and unpermitted vehicle access (minimum 5 times). Officers within this forest have experienced violent reprisal from armed hunters, and controlling access is problematic as gate-staff are regularly intimidated by hunters threatening their and their families' safety.

Rates of human-driven disturbances within the old logged forest (MBCA) were higher in contrast to Brodie et al., (2014). A total of 24 events were documented during my study: armed hunters or sandalwood harvesters caught on camera (5), and unarmed sandalwood harvester caught on camera (2). Seventeen observations of illegal activity were documented first-hand; name carvings on trees by sandalwood harvesters (1), cars parked by a river used for access to conduct hunting, fishing and sandalwood harvesting (3), illegal camps along the river (10), evidence of fishing (1), storage of ice for preserving hunted meat or fish (1), and clearing of the river for boat access (1). One camera was presumed stolen.

Illegal activity documented in the very old logged forest was widespread due to the large size of the reserve and multiple access methods around the reserve. Due to this, it is expected that many instances went undocumented. Hunting of banteng was supposedly conducted by villagers from Dagat in the north of Tabin. Here, illegal logging was particularly noticeable, with numerous large rivers aided the removal of timber but also facilitated hunting and fishing activity. I documented 27 observations which included hunters armed with firearms on foot (2), suspected armed hunters using car (1), unarmed men (2), dogs (2), shotgun shells (2), unarmed fishermen (3), fishing nets and lines (2), snares (3), hunting trails (3), hunters tracks (1), sack used for carrying meat or fish (1), crossbow (1), unwarranted vehicle noise (2), illegal logging (>2). Two camera trap units were also stolen just beyond the housing complex and road leading to the core of the forest.

4.5 Discussion

4.5.1 Activity patterns

Combining data from multiple sources with variations in sampling design and camera trap models is highly contentious. However, I justified the inclusion of camera trap data from other researchers based on 1) the use of passive detection systems shared by all camera trap models used, 2) rarity of the banteng and the difficulty in obtaining behavioural data, 3) the ability to address disproportionate sampling (i.e. uneven quantities of data available for each forest arising from variation in the number of camera traps installed in each forest) and the effects of hour, season and forest within the bootstrapped model, and 4) because it maximised the potential for conducting statistical analysis and increased the robustness of model estimates. One issue not accounted for within this study was the differences in detection success arising from the different camera trap brands, which probably influenced the frequency of captures to some degree. Only passive infrared systems were used during this study, and these generally have wider detection zones than active systems (Swann et al., 2004). Camera traps in general differ in their sensitivity and ability to detect events (Swann et al., 2004); a lower camera trap placement (20cm) of six different models (none of which were used in this study) gave rise to more captures at three distances than at a higher position (120cm). As camera trap positions in this study included a lower (30cm) and higher placement (100-150cm) this may suggest that the lower placement of cameras used to record wild felids (30cm) may have been as consistent in their detection of banteng as cameras placed higher.

Disparities in sampling effort together with uneven population sizes and the difficulty in obtaining photographic captures of banteng resulted in unequal quantities of data available for each forest. Previous wildlife activity studies with uneven sampling effort and multiple study sites generally report activity patterns as percentage frequencies (e.g. Azlan & Sharma, 2006; Barrueto et al., 2014; Gray & Phan, 2011). I attempted to account for these differences whilst maximising the potential of the data and address important questions governing behaviour through bootstrapping of observations, which were collected during both the wet and dry season. My study collected and compiled the largest and most complete dataset ever recorded for the banteng, which combined multiple herds within three geographically-distinct forests in Sabah. Accumulating data from other researchers resulted in a dataset which spanned a period of six years, and together I present one of the longest camera trap studies

ever conducted for a single species within Sabah. Peaks in banteng activity varied according to post-logging regeneration age; banteng in forest that was recently logged over seven years ago (MFR) exhibited a clear bimodal pattern in contrast to peak temperatures, which was consistent with activity patterns of banteng documented in Cambodia and Java (van Schaik 1996; Phan & Gray 2010) and with the closely-related gaur (*Bos gaurus*) in India (Ramesh et al., 2012). Activity in old logged forest (MBCA) was predominately unimodal with one strong peak over late afternoon and early evening when temperatures were cooling down. In the very old logged forest (TWR) activity occurred at a higher frequency throughout the day, with a strong peak in over the early morning hours. I found banteng activity contrasted that of coexisting ungulate game species targeted by hunters for their large body mass, namely bearded pig (*Sus barbatus*) and sambar deer (*Rusa unicolour*). These species experience the same habitat disturbances as the banteng yet their behavioural patterns do not correspond (see Ross et al., 2013); the sambar deer has been described as strongly nocturnal whilst the bearded pig is either crepuscular or diurnal for male and female, respectively.

4.5.2 Effect of forest regeneration upon ambient temperatures

Post-logging regeneration of highly disturbed dipterocarp forest can take upwards of 15 years before any signs of tree establishment are evident (Pinard et al., 1996) whilst regeneration of (selectively) logged forest to pre-logged carbon storage levels takes an estimated 120 year (Pinard & Cropper 2000). Heavy and prolonged vehicle usage in stumping and log preparation areas causes soil compaction which creates unfavourable conditions for seedling recruitment, and skid trails and log preparation areas can remain visibly empty of trees for many years (Pinard et al., 1996). Post-logging forest fires can prevail in the years following timber harvesting, and this further inhibits succession and regeneration of above and below ground tree biomass (Woods 1989; Pinard & Cropper 2000; Chidumayo 2014). Conversely, intense forest fires promote growth of pioneer grasses, herbs and vines (Woods 1989) which, together with any residual vegetation, proliferates during the initial stages of succession (Pinard et al., 1996). During this period (0-8 years), I observed mean temperatures in-excess of 33°C. The highest recorded temperature for this forest in open canopy was 44°C, which corresponded with Pinard et al., (1996) who documented ambient temperatures in the same lowland dipterocarp habitat and the adjacent forest patch, Ulu-Segama Forest Reserve. Temperature is one of the most important environmental variables governed by the tree stratum; a reduction in tree density and continuous canopy cover results in an increased exposure of the forest floor to direct sunlight which increases the ambient temperature

(Bergstedt & Milberg 2001). The two highest temperatures were recorded within forest that had the least regeneration time and consequently the least leaf litter, inside an open area than was previously logged using a crawler tractor. An additional (approx.) seven years of forest regeneration did little to lower peak temperatures; however the high temperatures were not sustained for long periods in this mature forest. Overall, temperatures within the very old logged forest were, on average, the lowest and temperatures over 30°C were sustained for the least time. Morning and evening temperatures were the coolest of all forests within an open canopy, indicating leaf litter is also a positive insulator to retain heat. Elevation, climate and early logging techniques were loosely consistent throughout all forests therefore advanced leaf cover is considered the primary factor regulating temperature. My data provides evidence to support the notion of a gradient between post-logging regeneration time, leaf cover and ambient temperatures which has not been previously factored in the measure of forest sustainability, particularly in relation to the effects upon wildlife.

The obvious limitation of using temperature data originating from camera trap images of banteng was the opportunistic nature of the measurements of temperature when activity occurred rather than systematic monitoring using weather stations as used by Allred et al., (2013) and Shrestha et al., (2014), which were used to investigate thermo-mediated behaviour of ungulates. Continuous monitoring of temperature using data loggers in different site features (i.e. open canopy, closed canopy, hill tops, and dense forest) like Giné et al (2012) would have provided a more robust method of assessing differences within forests and between forests, and prevented the need for interpolating the dataset when temperature values were absent because activity ceased. An additional unanticipated temperature-related issue arose from an increase in the apparent ambient temperature when a banteng stood near the camera for a short while or when a large group congregated nearby for a prolonged period (3°C rise in one observation).

4.5.3 Thermo-regulated activity budgets

Similar to the activity of African buffalo (*Syncerus caffer*) (Owen-Smith & Goodall 2014), banteng respond strongly to the diel cycle in temperature and that the thermal stress they experienced during the middle hours of the day limited the ability to remain active. In recently logged forest where structural change was severe and leaf cover was least, banteng coped with temperature peaks by conducting energy-demanding activities such as grazing and travelling during the cool early morning hours in open canopy and along logging roads

and conversely, least energetic activities under a closed canopy during midday heat. It is likely that rumination primarily took place during the cooler periods because it is limited by ambient temperature (Soriani et al., 2013), however as the 'other' behavioural category combined three specific behaviours it was not possible to conclude this without further stratification of the dataset. In all forests, banteng curtailed energy-demanding activity during the midday period in an open canopy. However, in forest with a longer regeneration time and higher leaf cover the banteng activity was less constrained. As continual locomotion in full sun can potentially lead to a lethal rise in core body temperatures in endotherms (Rowe et al., 2013) the presence of continual canopy cover and water source is essential to mitigate heat retention but also allow activity to continue throughout the day. During this study I did not observe wallowing behaviour however it cannot be ruled out as I made no explicit effort to [exclusively] monitor rivers and waterholes. I observed banteng mitigating heat-stress by regulating site-specific behaviours and switching to closed canopy areas where they performed less energy-demanding activities like resting and social interaction during midday heat. Resting behaviour was not always characterised by sitting and dozing but by apparent aimless wandering around a localised area for some hours. For this reason it may have been possible to confuse such behaviour with travelling. It is possible that travel was underestimated due to the short periods in which a travelling banteng would appear in front of the camera. The frequent occurrence of travel in the very old logged forest, however, suggests that I obtained sufficient data to represent the different behaviours. With regards to open canopy sites, in the old logged forest (MBCA) open grassland areas were confined to the immediate area surrounding the main access road. These areas were seldom used by banteng, possibly due to increased traffic to/from the nearby field studies centre and including dawn and dusk wildlife spotting excursions for ecotourism. The presence of open areas within the very old logged forest (TWR) was highly restricted due to a predominately closed canopy cover; banteng therefore frequented the grassy borders of the main access road in the west of TWR which is parallel to the forest edge. Their use of this area was constrained to night-time and dawn when human disturbances were minimal. Despite observations of their signs, banteng were only directly observed on one occasion in a private hunting grassland area adjacent to the forest edge. This area provided an abundance of grasses sufficient to support a large herd. Internal openings within the old logged forest (TWR) were generally few and small in size with limited forage, whilst tree growth had shaded out ground vegetation along many of the old logging roads. In the recently logged forests (MFR) internal openings were more prevalent. No examples of foraging under a closed canopy were made

during this study, which corresponds with a small study on the foraging behaviour of banteng (Ridge n.d.). Within forest with longer regenerating times and high leaf cover where banteng were not observed resting for long periods in large groups. It is possible that as internal foraging sites were fewer and smaller, banteng had to invest more energy searching for forage to meet the energy requirements of their large body size. Furthermore, a dense forest may prevent banteng from travelling together in large herds; therefore they may also spend long periods of time travelling to search for mates and to maximise the opportunity to socialise.

4.5.4 Hunting of banteng and habitat encroachment

During this study, human-driven disturbances were recorded in all three forests. Hunting of large mammals was conducted on foot, by car, motorbike and boat using firearms, spear-guns, crossbows, snares, spear and dogs. Removal of road-kill was also encountered within a different forest (Ulu-Segama Forest Reserve). Illegal timber harvesting and the collection of highly-prized sandalwood were an on-going issue within the study sites. Hunting has been identified as one of the primary causes driving the decline of banteng for many decades (Davies & Payne, 1982) and forestry staff are under considerable pressure to control unwarranted encroachment by aggressive armed hunters. I did not endeavour to identify any possible fine-scale alteration in behaviour caused by hunting because generally encounters result in mortality. With the exception of locating remnant herds across the state of Sabah I believe that further research is secondary to implementing physical measures to prevent the decline of the banteng in Sabah due to hunting. Addressing the issue of unwarranted access into protected forests should be a priority. Based on local reports, at least three banteng were shot in Sabah during the course of my study in protected forests. However, I suspect this number to be much higher due to the demand for banteng meat and horn and the rampant hunting activity which persists across the state. Older reports of banteng poaching were passed on first-hand by logging contractors and local villagers, whilst second-hand reports were received from conservation workers who had witnessed banteng carcasses coming out from a protected forest. In different forests occupying the interior of Sabah, banteng trophies were occasionally shown to the author to substantiate historic hunting stories. However, these expeditions did not form part of this study. Numerous banteng artefacts have also been recorded in long-houses across the border in Kalimantan (Indonesian Borneo) by Hedges and Meijaard (1999).

4.5.5 Conservation of banteng

Banteng were recorded in areas of heavily degraded forest within two years following logging activity which is testament to the tolerance of the species. Severe structural and environmental change to forest can be detrimental for heat regulation of banteng, due to decrease in cover and increase in predation risk, and induced stress (which has not been investigated in this study). Conversely, logging can instigate growth of pioneer plant species during the early stages of regeneration, which provides important forage for banteng (Ridge n.d.) and gives rise to higher body condition scores (Prosser n.d.). Sadly, timber harvesting of prime banteng habitat continues in Sabah, and minimising the deleterious impacts is fundamental to conservation of banteng. At present, sustainability of logging is not measured in terms of disturbance to wildlife behaviour but severe disruptions to this can potentially have a knock-on effect on species longevity. Two factors which were not measured for this study but would serve as an alternative indication of logging and ecosystem sustainability are: 1) the stress-induced alteration in behaviour over a time-gradient documented from pre-logging to post-logging activity, and 2) the levels of hunting experienced before, during and after logging activity including the hunting activity by logging contractors. To prevent decimation of banteng populations, immediate achievable steps should be taken; implementation of locked barricades that are impenetrable to vehicles along logging road networks, and armed check points at forest access points are an effective prevention measures. To some extent they are being effectively implemented in some forests (e.g. New Forests Ltd. 2008). Despite this, rangers require further empowerment in the form of firearms to protect them when they patrol banteng habitat, to reinforce the no-hunting policy adopted by forest reserves across Sabah and to confiscate banteng products. Prevention of international trade in banteng trophies and biological products used for medicinal value could be facilitated by inclusion of the banteng into CITES (Convention on International Trade in Endangered Species), previously proposed almost two decades ago by Hedges (1996).

4.7 References

- Allred, B.W., Fuhlendorf, S.D., Hovick, T.J., Dwayne Elmore, R., Engle, D.M. & Joern, A., 2013. Conservation implications of native and introduced ungulates in a changing climate. *Global Change Biology*, 19(6), pp.1875–1883.
- Ancrenaz, M., Ambu, L., Sunjoto, I., Ahmad, E., Manokaran, K. & Lackman, I., 2010. Recent surveys in the forests of Ulu Segama Malua, Sabah, Malaysia, show that orangutans (*P. p. morio*) can be maintained in slightly logged forests. *PloS One*, 5(7), e11510.
- Ancrenaz, M., Sollmann, R., Meijaard, E., Hearn, A.J., Ross, J., Samejima, H., Loken, B., Cheyne, S.M., Stark, D.J., Gardner, P.C., Goossens, B., Mohamed, A., Bohm, T., Matsuda, I., Nakabayasi, M., Lee, S.K., Bernard, H., Brodie, J., Wich, S. et al., 2014. Coming down from the trees: Is terrestrial activity in Bornean orangutans natural or disturbance driven? *Nature: Scientific Reports*, 4, e4024.
- Azlan, M.J. & Sharma, D.S.K., 2006. The diversity and activity patterns of wild felids in a secondary forest in Peninsular Malaysia. *Oryx*, 40(1), p.36–41.
- Barrueto, M., Ford, A.T. & Clevenger, A., 2014. Anthropogenic effects on activity patterns of wildlife at crossing structures. *Ecosphere*, 5(3). p. 27.
- Van Beast, F.M., Van Moorter, B. & Milner, J.M., 2012. Temperature-mediated habitat use and selection by a heat-sensitive northern ungulate. *Animal Behaviour*, 84, pp.723–735.
- Bergstedt, J. & Milberg, P., 2001. The impact of logging intensity on field-layer vegetation in Swedish boreal forests. *Forest Ecology and Management*, 154(1-2), pp.105–115.
- Bernard, H., Brodie, J., Giordano, A.J., Hamid Ahmad & Sinun, W., 2013. Bornean felids in and around the Imbak Canyon Conservation Area, Sabah, Malaysia. *CATnews*, 58, pp.1–6.
- Boan, J.J., McLaren, B.E. & Malcolm, J.R., 2011. Influence of post-harvest silviculture on understory vegetation: Implications for forage in a multi-ungulate system. *Forest Ecology and Management*, 262(9), pp.1704–1712.
- Brodie, J. & Giordano, A., 2011. Small carnivores of the Maliau Basin, Sabah, Borneo, including a new locality for Hose's Civet *Diplogale hosei*. *Small Carnivore Conservation*, 44(6), pp.1–6.
- Brodie, J.F., Giordano, A.J. & Ambu, L., 2015. Differential responses of large mammals to logging and edge effects. *Mammalian Biology*, 80(1), pp.7–13.
- Buckland, S.T., 1984. Monte Carlo confidence intervals. *Biometrics*, 40, pp.811–817.
- Caterpillar, 2014. Caterpillar: D series track-type loaders. Available at: http://www.cat.com/en_US/products/new/equipment/track-loaders/medium-track-loaders/14129604.html.

- Chidumayo, E., 2014. Estimating tree biomass and changes in root biomass following clear-cutting of *Brachystegia-Julbernardia* (miombo) woodland in central Zambia. *Environmental Conservation*, 41(1), pp.54–63.
- Cruz, P., Paviolo, A., Bó, R.F., Thompson, J.J. & Di Bitetti, M.S., 2014. Daily activity patterns and habitat use of the lowland tapir (*Tapirus terrestris*) in the Atlantic Forest. *Mammalian Biology*, 79(6), pp.376–383.
- Davies, G. & Payne, J., 1982. *A faunal survey of Sabah*, World Wildlife Fund - Malaysia.
- Fan, P.-F., Fei, H.-L. & Ma, C.-Y., 2012. Behavioral responses of Cao Vit gibbon (*Nomascus nasutus*) to variations in food abundance and temperature in Bangliang, Jingxi, China. *American Journal of Primatology*, 74(7), pp.632–41.
- Fewster, R.M., Buckland, S.T., Siriwardena, G.M., R, B.S. & Wilson, J.D., 2000. Analysis of population trends for farmland birds using generalised additive models. *Ecology*, 81(7), pp.1970–1984.
- Gaveau, D.L., Sloan, S., Molidena, E., Yaen, H., Sheil, D., Abram, N.K., Ancrenaz, M., Nasi, R., Quinones, M., Wielaard, N. & Meijaard, E., 2014. Four decades of forest persistence, clearance and logging on Borneo. *PLoS One*, 9(7), e101654.
- Giné, G.A.F., Duarte, J.M.B., Motta, T.C.S. & Faria, D., 2012. Activity, movement and secretive behavior of a threatened arboreal folivore, the thin-spined porcupine, in the Atlantic forest of southern Bahia, Brazil. *Journal of Zoology*, 286(2), pp.131–139.
- Gray, T.N.E. & Phan, C., 2011. Habitat preferences and activity patterns of the larger mammal community in Phnom Prich Wildlife Sanctuary, Cambodia. *The Raffles Bulletin of Zoology*, 59(2), pp.311–318.
- Hedges, S., 1996. *Proposal for inclusion of banteng (Bos javanicus) in CITES Appendix I*.
- Hedges, S. & Meijaard, E., 1999. *Reconnaissance survey for banteng (Bos javanicus) and banteng survey methods training project, Kayan-Mentarang National Park, East Kalimantan, Indonesia*.
- Ibbotson, R., 2014a. The development of rail transportation in the logging industry. In *The history of logging in North Borneo*. Kota Kinabalu: Opus Publications, pp. 146–148.
- Ibbotson, R., 2014b. The introduction of crawler tractors to the logging industry. In *The history of logging in North Borneo*. Opus Publications, pp. 212–215.
- Kosheleff, V.P. & Anderson, C.N.K., 2009. Temperature's influence on the activity budget, terrestriality, and sun exposure of chimpanzees in the Budongo Forest, Uganda. *American Journal of Physical Anthropology*, 139(2), pp.172–81.
- Kuo, C. & Lee, L.-L., 2012. Home range and activity of the Indian giant flying squirrel (*Petaurista philippensis*) in Taiwan: influence of diet, temperature and rainfall. *Acta Theriol*, 57, pp.269–276.

- Lafleur, M., Sauther, M., Cuzzo, F., Yamashita, N., Jacky Youssouf, I.A. & Bender, R., 2013. Cathemerality in wild ring-tailed lemurs (*Lemur catta*) in the spiny forest of Tsimanampetsotsa National Park: camera trap data and preliminary behavioral observations. *Primates; journal of primatology*, pp.207–217.
- Logfisher International Sdn. Bhd., 2014. Logfisher. Available at: <http://www.logfisher.com/about.html>.
- Lynam, A.J., Jenks, K.E., Tantipisanuh, N., Chutipong, W., Ngoprasert, D., Gale, G.A., Steinmetz, R., Sukmasuang, R., Bhumpakphan, N., Grassman Jr., L.I., Cutter, P., Kitamura, S., Reed, D.H., Baker, M.C., Mcshea, W., Songsasen, N. & Leimgruber, P., 2013. Terrestrial activity patterns of wild cats from camera-trapping. *Raffles Bulletin of Zoology*, 61(1), pp.407–415.
- Melletti, M. & Burton, J. eds., 2014. *Ecology, evolution and behaviour of wild cattle: Implications for conservation*, Cambridge: Cambridge University Press.
- Metz, J.H.M., 1975. *Time patterns of feeding and rumination in domestic cattle*, Rotterdam: Veenman.
- Neumann, W., Ericsson, G., Dettki, H. & Radeloff, V.C., 2013. Behavioural response to infrastructure of wildlife adapted to natural disturbances. *Landscape and Urban Planning*, 114, pp.9–27.
- New Forests Ltd., 2008. *Malua Forest Reserve conservation management plan*, Available at: http://www.maluabank.com/downloads/Malua_CMP.pdf.
- Oliveira-Santos, L.G.R., Machado-Filho, L.C.P., Tortato, M.A. & Brusius, L., 2010. Influence of extrinsic variables on activity and habitat selection of lowland tapirs (*Tapirus terrestris*) in the coastal sand plain shrub, southern Brazil. *Mammalian Biology - Zeitschrift für Säugetierkunde*, 75(3), pp.219–226.
- Owen-Smith, N., Fryxell, J.M. & Merrill, E.H., 2010. Foraging theory upscaled: the behavioural ecology of herbivore movement. *Philosophical Transactions of the Royal Society of London. Series B, Biological Sciences*, 365(1550), pp.2267–78.
- Owen-Smith, N. & Goodall, V., 2014. Coping with savanna seasonality: comparative daily activity patterns of African ungulates as revealed by GPS telemetry. *Journal of Zoology*, 293(3), pp.181–191.
- Payne, J., Francis, C.M., Phillips, S.S. & WWF-Malaysia, 1985. *A field guide to the mammals of Borneo*, Kota Kinabalu: The Sabah Society, Malaysia.
- Phan, C. & Gray, T.N.E., 2010. Ecology and natural history of banteng in eastern Cambodia: evidence from camera trapping in Mondulkiri Protected Forest and Phnom Prich Wildlife Sanctuary. *Cambodian Journal of Natural History*, 2010(2), p.118.
- Pinard, M. & Cropper, W., 2000. Simulated effects of logging on carbon storage in dipterocarp forest. *Journal of Applied Ecology*, 27, pp.267–283.

- Pinard, M., Hewlett, B. & Davidson, D., 1996. Site conditions limit pioneer tree recruitment after logging of dipterocarp forests in Sabah, Malaysia. *Biotropica*, 28(1), pp.2–12.
- Prosser, N., *A body condition scoring system for the Bornean banteng (Bos javanicus lowi) and the effect of forest management and the wet and dry season on these scores in Sabah, Malaysia*. BSc PTY report, Cardiff University.
- Ramesh, T., Kalle, R., Sankar, K. & Qureshi, Q., 2012. Spatio-temporal partitioning among large carnivores in relation to major prey species in Western Ghats N. Bennett, ed. *Journal of Zoology*, 287(4), pp.269–275.
- Ridge, S., *Daily foraging times and foraged species of banteng in Sabah*. BSc PTY report, Cardiff University.
- Ross, J., Hearn, J., Johnson, P.J. & Macdonald, D.W., 2013. Activity patterns and temporal avoidance by prey in response to Sunda clouded leopard predation risk. *Journal of Zoology*, 290(2), pp.96–106.
- Rowe, M.F., Bakken, G.S., Ratliff, J.J. & Langman, V.A., 2013. Heat storage in Asian elephants during submaximal exercise: Behavioral regulation of thermoregulatory constraints on activity in endothermic gigantotherms. *Journal of Experimental Biology*, 216(10), pp.1774–1785.
- Sabah Forestry Department, 2005. Class 7: Tabin Wildlife Reserve. Available at: http://www.sabah.gov.my/htan_caims/Level 2 frame pgs/Class 7 Frames/tabin_fr.htm [Accessed May 7, 2009].
- Sabah Forestry Department, 2014. Sustainable management. Available at: <http://www.forest.sabah.gov.my/en/discover/sustainable-management/helicopter-logging>.
- Van Schaik, C.P., 1996. Activity periods of Indonesian rain forest mammals. *Biotropica*, 28(1), pp.105–112.
- Sheil, D. & Meijaard, E., 2008. The persistence and conservation of Borneo's mammals in lowland rain forests managed for timber: observations, overviews and opportunities. *Ecological Research*, 23(1), pp.21–34.
- Shrestha, A.K., van Wieren, S.E., van Langevelde, F., Fuller, A., Hetem, R.S., Meyer, L., de Bie, S. & Prins, H.H.T., 2014. Larger antelopes are sensitive to heat stress throughout all seasons but smaller antelopes only during summer in an African semi-arid environment. *International journal of biometeorology*, 58(1), pp.41–9.
- Sollmann, R., Tôrres, N.M., Furtado, M.M., de Almeida Jácomo, A.T., Palomares, F., Roques, S. & Silveira, L., 2013. Combining camera-trapping and noninvasive genetic data in a spatial capture–recapture framework improves density estimates for the jaguar. *Biological Conservation*, 167, pp.242–247.

- Soriani, N., Panella, G. & Calmari, L., 2013. Rumination time during the summer season and its relationships with metabolic conditions and milk production. *Journal of Dairy Science*, 96(8), pp.5081–5094.
- Swann, D.E., Hass, C.C., Dalton, D.C. & Wolf, S. a., 2004. Infrared-triggered cameras for detecting wildlife: an evaluation and review. *Wildlife Society Bulletin*, 32(2), pp.357–365.
- Thorn, M., Scott, D.M., Green, M., Bateman, P.W. & Cameron, E.Z., 2009. Estimating brown hyaena occupancy using baited camera traps. *South African Journal of Wildlife Research*, 39(1), pp.1–10.
- Timmins, R.J., Duckworth, J.W., Hedges, S., Steinmetz, R. & Pattanavibool, A., 2008. *Bos javanicus*. In: IUCN 2012. IUCN Red List of threatened species. www.iucnredlist.org. Available at: www.iucnredlist.org/details/biblio/2888/0.
- Tobler, M.W., Carrillo-Percastegui, S.E. & Powell, G., 2009. Habitat use, activity patterns and use of mineral licks by five species of ungulate in south-eastern Peru. *Journal of Tropical Ecology*, 25(03), p.261-271.
- Wearn, O.R., Rowcliffe, M.J., Carbone, C., Bernard, H. & Ewers, R.M., 2013. Assessing the status of wild felids in a highly-disturbed commercial forest reserve in Borneo and the implications for camera trap survey design. *PLoS One*, 8(11), e77598.
- Wong, W.M., Leader-Williams, N. & Linkie, M., 2013. Quantifying changes in sun bear distribution and their forest habitat in Sumatra. *Animal Conservation*, 16(2), pp.216–223.
- Woods, P., 1989. Effects of logging, drought, and fire on structure and composition of tropical forests in Sabah, Malaysia. *Biotropica*, 21(4), pp.290–298.
- Zeileis, A., Grothendieck, G., Ryan, J.A. & Andrews, F., 2014. Package “zoo.” Available at: <http://zoo.r-forge.r-project.org/>.

4.8 Appendices

Conventional logging: Conventional logging in Sabah utilizes chainsaws (Stihl 070) and bulldozers (D7F Caterpillar). Prior to harvesting, the fellers and bulldozer operators cruise the area to determine the approximate locations of trees, roads and skid trails (map scale 1: 50 000 with contour intervals of 50 m). During harvesting, a team of one or two fellers locates commercial trees. All trees above 60 cm DBH are felled except those with visible defects. Fruit trees and trees of less than 60 cm DBH are not cut. Generally, timber fellers have complete freedom over the direction and method of felling. Consequently, felling damage can be excessive in uncontrolled logging and as much as 62 percent of stems suffer total damage (Fox, 1968). However, the severe felling damage in Sabah is also caused by high felling intensity of 8-15 trees/ha above 60 cm DBH (i.e. 80-150 m³/ha). In addition, the abundance of climbers or lianas (500-900 m³/ha) significantly influences felling damage by pulling down and uprooting neighbouring trees. After a tree is felled, it is trimmed to a log length of about 6 m. Logs are then extracted to the roadside by bulldozers. The bulldozer team determines the layout of the skid trail and leaves a pattern of extravagant skid trails (Ibbotson 2014b).

Crawler tractor logging: Historic logging practices using steam were replaced in (circa) 1940 with the tracked bulldozer Caterpillar D7E & D8 which were equipped with Hyster winches and Caterpillar hydraulic, angle bulldozer blades (Ibbotson 2014a). Present day Caterpillar or crawler tractors are still equipped with tracked shoes on rollers, hydraulic buckets and dozers for lifting, digging, excavating and grading roads for timber extraction, and rear attachments which can plough or rip through the forest floor and hitch up logs for extraction (Caterpillar 2014).

Log-Fisher logging (RIL): A tracked harvester with a hydraulic bucket and grapples to dig, excavate, compact and trim slopes with a long distance cable crane and pulley enabling winching of timber from height and long range which reduces soil compaction, prevents damage to non-target stems, and decreases the width of forest floor extraction corridors (Logfisher International Sdn. Bhd. 2014).

Heli-logging (RIL): Heli-logging was first introduced to Sabah in 2004 and is conducted primarily in steep terrain where terrestrial tracked vehicles are unsuitable, to minimise damage to non-target stems, and reduce the creation of roads required for extraction of timbers (Sabah Forestry Department 2014).

Appendix 4.1: Four different methods of logging used in Sabah (Malaysia Borneo) within tropical dipterocarp forests over the past six decades up until present-day: conventional, traditional and newer Reduced Impact Logging (RIL) techniques. Generally speaking traditional logging methods are more destructive and result in heavy impactation of the substrate, which provides favourable conditions for invasive pioneer species that banteng forage upon.



Appendix 4.2: Evidence of illegal activity collected since 2011. From top, left-right: Armed hunter that was part of a group of six men which stole camera traps used for banteng surveys (MFR), illegal deforestation of timber adjacent to a large river within a totally protected wildlife reserve by a nearby village, for use for building houses (TWR), hunter from a nearby oil palm plantation hunting using a more traditional method rarely seen: a long spear with a dog (MFR), a forest barricade implemented by an oil palm plantation which shared the border with a totally protected forest reserve. Usually this gate is usually locked at night to prevent vehicle access to the forest however on this occasion it was left unlocked for illegal hunting activity – the gate was driven over by hunters in a 4x4 during an early morning car chase (TWR), a large group of armed hunters which spotted a camera trap for banteng surveys (MBCA), illegal harvesters with full bags of sandal wood transporting it out of the forest at night to avoid capture by rangers posted at the main access gate (MBCA).

Chapter 5: Population genetic structure of the Bornean banteng (*Bos javanicus lowi*)

5.1 Abstract

The Bornean banteng (*Bos javanicus lowi*) is in danger of extinction. Within the Malaysian state of Sabah which is their last stronghold, their population has contracted to less than 500 individuals. Habitat loss and hunting for bush meat and the perceived medicinal properties of their horn are driving their decline. Prior to 2014, information on their genetic diversity was non-existent, and knowledge of their ecology and behaviour was limited. Conservation action plans for banteng require information on their phylogenetic distinctiveness to justify separate management, and a description of their genetic diversity and its distribution across the landscape are imperative for developing specific management protocols. To increase the understanding of this rare species and to facilitate the creation of the first action plan for banteng, non-invasively collected biological material and a [concatenated] fragment of 1,368bp of mitochondrial DNA were used to investigate genetic diversity of banteng within four forest reserves in Sabah. The resulting data set comprises the largest sample size for wild populations of banteng and one of the longest mtDNA fragments of the Bornean banteng ever obtained, which therefore increased the accuracy of genetic diversity assessment. A total of six haplotypes were found; five haplotypes were distinguishable by one substitution and one haplotype was distinguishable by four substitutions, and a phylogenetic network was constructed to give insights into the relationships between haplotypes, revealing a star-shaped phylogeny that is consistent with a scenario of population expansion following colonisation. Statistical deviations from neutrality (i.e. a population that has not experienced expansion) also provided a signal of population expansion. The distribution of haplotypes across the landscape was not strongly structured, suggesting that banteng have not been historically constrained by topographical features. I found evidence of banteng divergence from gaur (*Bos gaurus*) circa 217 to 634 kya, and the arrival of banteng into Borneo between 55-355 kya. The current distribution of haplotypes and their frequencies suggest that the population could be managed as two separate units. Additional faecal samples currently being obtained from other banteng populations in Sabah may help identify more haplotypes and elucidate additional management units. My attempt to amplify nuclear DNA from faecal samples using microsatellite markers was unsuccessful due to low amplification. However, DNA from tissue samples (highly difficult to obtain for the Bornean banteng) may improve amplification success, and facilitate the estimation of nuclear genetic diversity and population structure.

5.2 Introduction

Habitat fragmentation and population isolation is a serious concern for the future conservation of rare mammals (Hu et al., 2010). Habitat connectivity and animal movement are essential for maintaining gene flow and genetic diversity (Hu et al., 2010) and when barriers in the landscape occur, such as land-use change (e.g. monoculture plantations: oil palm (*Elaeis guineensis*), rubber and commercial timber (*Ficus elastica*)) and also natural topographical barriers (e.g. rivers, mountains) they can inhibit gene exchange (Frankham et al., 2010). Restricted gene flow due to human activities can be highly deleterious in the long-term and can lead to greater spatial genetic structure (Hu et al., 2010), inbreeding depression, rapid loss of genetic diversity and an elevated risk of extinction (Frankham et al., 2010). Markers of the mitochondrial DNA (mtDNA) have been a favoured tool due to the mitochondria's relatively rapid pace of evolution, the non-recombining mode of inheritance (Avice 1994) and a relatively high amplification success using non-invasive samples (Goossens et al., 2005). Better quality DNA from blood and tissue samples permit whole-genome (including whole mitogenome) analysis, facilitating investigations of landscape genomics and landscape legacies (Bolliger et al., 2014; Shafer et al., 2014) however for some elusive and rare species, better quality DNA is not available. Mitochondrial DNA can help reveal past demographic events such as introgression, population expansion, and geographical determinants of isolation that have led to the present distribution of genetic lineages across the landscape (Frankham et al., 2010; Hickerson et al., 2010; Seabra et al., 2014). Such insights can enable wise conservation decisions of both habitat and target species (Hu et al., 2010; Arora et al., 2010; Nater et al., 2011).

Over recent decades Borneo's mammals have experienced severe habitat fragmentation, with intensive forest clearance and land conversion to monoculture plantations at a pace that is nearly twice as fast as the rest of the world's humid tropical forests (Gaveau et al., 2014). The significance of fragmentation for conservation of Bornean forest genetic resources of both flora and fauna taxa remains poorly understood (Ismail et al., 2014) except for the orang-utan (*Pongo*), which has been the focus of the majority of molecular studies among these taxa (Goossens et al., 2005; Goossens et al., 2006; Arora et al., 2010; Nater et al., 2011; Nietlisbach et al., 2012). Natural riparian systems have been found to be a significant barrier to gene flow in orang-utans in Sabah (Goossens et al., 2005) and recent anthropogenic fragmentation of the habitat has caused significant declines in the population size (Goossens et al., 2006; Nater et al., 2014). In addition, forest clearance furthers the risk of decline by

creating logging roads which alter wildlife behaviour and render them more susceptible to hunting for bush meat (Ancrenaz et al., 2014; Brodie et al., 2014). Hunting can also impact upon the genetic structure of wildlife populations by changing population structure and promote merging of previously differentiated populations (e.g. Ferreira da Silva et al., 2014), remove genetic diversity and cause local extinction (Edwards et al., 2014). The effect of hunting however has not been widely tested for the majority of mammal species.

For the banteng (*Bos javanicus*), habitat fragmentation, inbreeding and hunting pose a real threat to conservation of their genetic diversity and long-term persistence in the wild (Bradshaw et al., 2006; Timmins et al., 2008). The rarest banteng subspecies (*Bos javanicus lowi*) is endemic to Borneo, with the last stronghold situated in Sabah. Parallels between the case study of the Bornean banteng and the exceptionally rare Sumatran rhinoceros (*Dicerorhinus sumatrensis*) can be drawn; both rare large mammals coexist at low-density in remote inhospitable habitat for humans and have experienced heavy declines in population size over recent decades as a result of habitat loss and hunting (Goossens et al., 2013; Timmins et al., 2008). The Sumatran rhinoceros is on the brink of extinction (Goossens et al., 2013) and the Bornean banteng appears to be following the same pattern of decline; remnant populations are highly fragmented in Sabah (Melletti & Burton 2014) with a preliminary indication of low genetic diversity in the finding of only two haplotypes in the mtDNA cytochrome-*b* gene and two in the control region by Matsubayashi (2014). Unlike the Sumatran rhinoceros, there are no captive populations of Bornean banteng and obtaining samples of tissue, blood or hair is logistically difficult. So far, no high quality tissue samples are available for this taxon. For this reason, molecular studies can only be conducted using non-invasively collected DNA. Only one study has investigated the population genetic structure of Bornean banteng to date; two short mtDNA fragments (cytochrome-*b* and control region/d-loop) and non-invasively collected DNA were used to delineate the population in three forests in Sabah (see Matsubayashi et al., 2014). Four sampling sites were selected on a) the basis of possible introgression with domestic cattle and b) a geographical gradient between forest and the nearest village with cattle. Bornean banteng did not cluster with the domestic cattle *Bos indicus*, rather they were a sister group of gaur (*B. gaurus*) suggesting introgression from domestic cattle into the maternal lineage had not occurred, or was not evident in i) the samples collected, or ii) the genetic marker used. The lack of polymorphism identified in the Bornean banteng, the limited substructure and the low genetic diversity are similar to the conclusions of Bradshaw et al., (2006) who investigated the feral banteng in

Australia (*B. j. javanicus*). The short fragment sizes used by Matsubayashi et al., (2014) limited the probability of detecting substitutions, and the small sample size constrained the statistical power of phylogenetic reconstruction (Bradshaw et al., 2006; Matsubayashi et al., 2014). In view of the considerable effort required to obtain fresh faecal samples and DNA of banteng, there remains considerable opportunity to maximise the potential of the data and strengthen the inferences of the phylogenetic analysis and this was, in part, identified by Matsubayashi et al., (2014). Molecular sex determination of samples could have been conducted using sex-specific markers located on the Y-chromosome that have been previously applied to banteng (see Rivière-Dobigny et al., 2009; Syed-Shabthar et al., 2013). Microsatellite markers for inferring the origin of the nuclear genome, which is influenced by male-mediated introgression, would also have been a valuable addition for estimating hybridization and for structure (see Nijman et al., 2003). Highly polymorphic microsatellite markers for cattle recommended by the Food and Agriculture Organization of the United Nations (FAO) (2011), mapped by Ihara et al., (2004) and applied in various studies to cattle (Bradshaw et al., 2007; Handiwirawan et al., 2003; Nijman et al., 2003; Rivière-Dobigny et al., 2009) could have been used to estimate genetic diversity and resolve the identity of faecal samples that were collected with knowledge of the individual. Previous application of microsatellites to Cambodian banteng (*B. j. birmanicus*) failed due to low amplification rates (see Pedrono et al., 2009). From a conservation management perspective, Matsubayashi et al., (2014) could not address the fundamental issues of gene flow and connectivity between banteng populations in Sabah due to a lack of polymorphism in the sequences examined.

An understanding of genetic diversity and structure is prerequisite of conservation management (Frankham et al., 2010) however current information on Bornean banteng is insufficient to effectively manage the population. This study attempted to identify the ancestral lineages in relation to other *Bos* species, provide molecular diversity data for banteng in four forest reserves in Sabah by estimating current levels of mtDNA genetic diversity, define haplotypes and estimate the spatial patterns of genetic variation.

5.3 Materials and methods

5.3.1 Samples

Samples of fresh faeces (estimated 0-72 hours old based on appearance) were collected on an ad-hoc basis from four forest reserves in the Malaysian state of Sabah in north Borneo (Figure 5.1): Tabin Wildlife Reserve, Ulu-Segama Malua Forest Reserve, Malua Forest Reserve and Maliau Basin Conservation Area and buffer zones between September 2011 and October 2013. Straight-line distances between reserves are: 160 km between Tabin and Maliau, 64 km between Malua and Maliau, and 43 km between Ulu-Segama and Maliau. Following the protocol commonly used for tropical apes (Sa 2012; see Arandjelovic et al., 2010; Ferreira da Silva 2012; Rodrigues 2012), approximately 25g of faecal material was added to 15ml of 95% ethanol (Sigma-Aldrich Co. LLC) for 24 hours and then transferred to silica gel (Sigma-Aldrich Co. LLC) for long-term storage which has been found to give best genotyping success (Soto-Calderón et al., 2009; Nsubuga et al., 2004). One sample collected by another researcher on my behalf was stored in RNAlater, and was also found to give high DNA yield over the long term (Nsubuga et al., 2004) but is more costly so was less useful for this study.

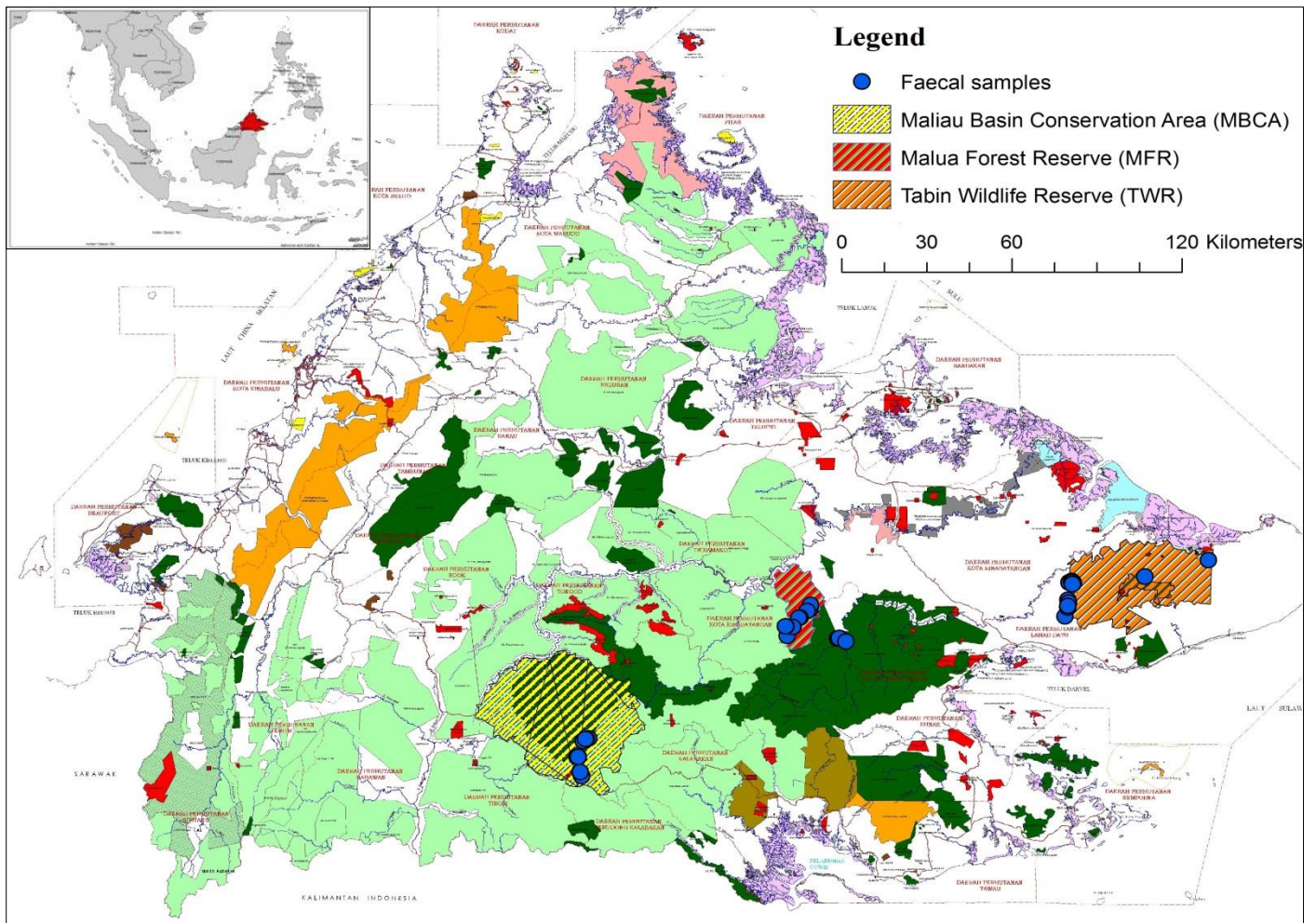

Figure 5.1: The position of Sabah, Malaysia Borneo, in Southeast Asia (*inset*) with the distribution of the forest reserves: Ulu-Segama Malua Forest Reserve, Maliau Basin Conservation Area, Malua Forest Reserve and Tabin Wildlife Reserve. Within each forest reserve are the precise locations of fresh faecal samples that were collected between years 2011-2013 and preserved using a two-step (ethanol/silica gel) method. Note, other colours relate to forest classification designated by the Sabah Forestry Department: Virgin jungle reserve (red), protected forest reserve (dark green), commercial forest reserve (light green), Sabah parks (orange), wildlife reserve (light blue), mangrove forest reserve (pink), and amenity forest reserve (brown).

5.3.2 Lab methodology

DNA extraction

DNA was extracted using the QIAGEN QIAamp® DNA Stool Kit following the manufacturer's protocol (Second Edition April 2010). Extraction steps were modified to maximise DNA yield (Appendix 5.1). Typical DNA concentrations obtained from the QIAGEN Stool Kit are typically 75-300µM.

Design of mitochondrial (mtDNA) markers

Four species-specific primer pairs were designed (Table 5.1) to amplify four overlapping fragments comprising the mitochondrial cytochrome-*b* gene, transfer RNA (tRNA) T and P, and control region/d-loop (Figure 5.2), spanning a fragment of approximately 1,500bp using 27 sequences from five *Bos* species available on GenBank (note, accession numbers can be found in Appendix 5.2). A reference sequence was created for designing primers by manually aligning and joining two sequences from *Bos javanicus* (accession number EU747735.1) and *Bos indicus* (accession number DQ887768.1) using BioEdit Sequence Alignment Editor (Hall, 1999). This was conducted due to an absence of long sequences from *Bos javanicus* on GenBank. Automatic alignment of GenBank sequences against the template was conducted by blasting sequences together using GenBank standard Nucleotide Basic Local Alignment Tool (BLAST®), which was used to identify regions with substitutions and less polymorphic regions suitable for primer design. Substitutions in suitable priming regions were coded as degenerate bases. Indices of primer quality (e.g. optimum melting temperature, GC content, stability, self-dimer and fragment length) were recorded and a simulated PCR was conducted using the software AmpfliX version 1.7.0 (Jullien 2013). For optimal sequencing success and quality, internal mtDNA primers were designed using AmpfliX. All primers were manufactured by Eurofins Genomics (Germany).

Table 5.1: Four sets of mitochondrial (mtDNA) primers designed to amplify highly degraded faecal DNA of the Bornean banteng. The primers amplify four shorter fragments in partial cytochrome-*b* gene, tRNA, and partial hypervariable Control region/d-loop. Two pairs internal primers were also designed for sequencing of PCR products as original primers resulted in poor quality sequences of fragments 2 and 4. The four fragments were concatenated using a contig in the software Sequencher 5.2.4.

Application	Gene/Region	Forward marker	Sequence 5'	Reverse marker	Sequence 3'	Amplified fragment size (bp)	T _m (°C)
PCR	Cytochrome- <i>b</i>	1F	ATCCTCACAGGCCTATTCCTAGCAA TACA	1R	GGTAAGGGTTGCTTTATCTACTGAGAA TC	395	58
PCR	Cytochrome- <i>b</i>	2F New	CATTCTGAGGAGCAACAGT	2R 02/10/14	TAGTTTGTGGGGATTGATCG	449	62
<i>Internal sequencing</i>		2F 18/11/14	GATTCTCAGTAGACARAGYAACCCDTA CC	2R 18/11/14	TGTGTTGAGTGGATTTGCG	293	
PCR	Cytochrome- <i>b</i> -tRNA	3F	CATGAATTGGAGGACAACCAGTCGA ACACC	3R	CGTGTTATGTTAGCTAGTGGTG	422	58
PCR	tRNA- Control region/d-loop	4F New	CTCATCCTAGTRCTAATACCAAC	4R Old	CGGCATGGTAATTAAGYTCGTGATCT	346	62
<i>Internal sequencing</i>		4F 18/11/14	GTAAAH CAGAGAAGGAGAACA	4R 18/11/14	TGCCAAGGACAGGTTTGACATTATGTGC	449	
<i>Total fragment size</i>						1559	

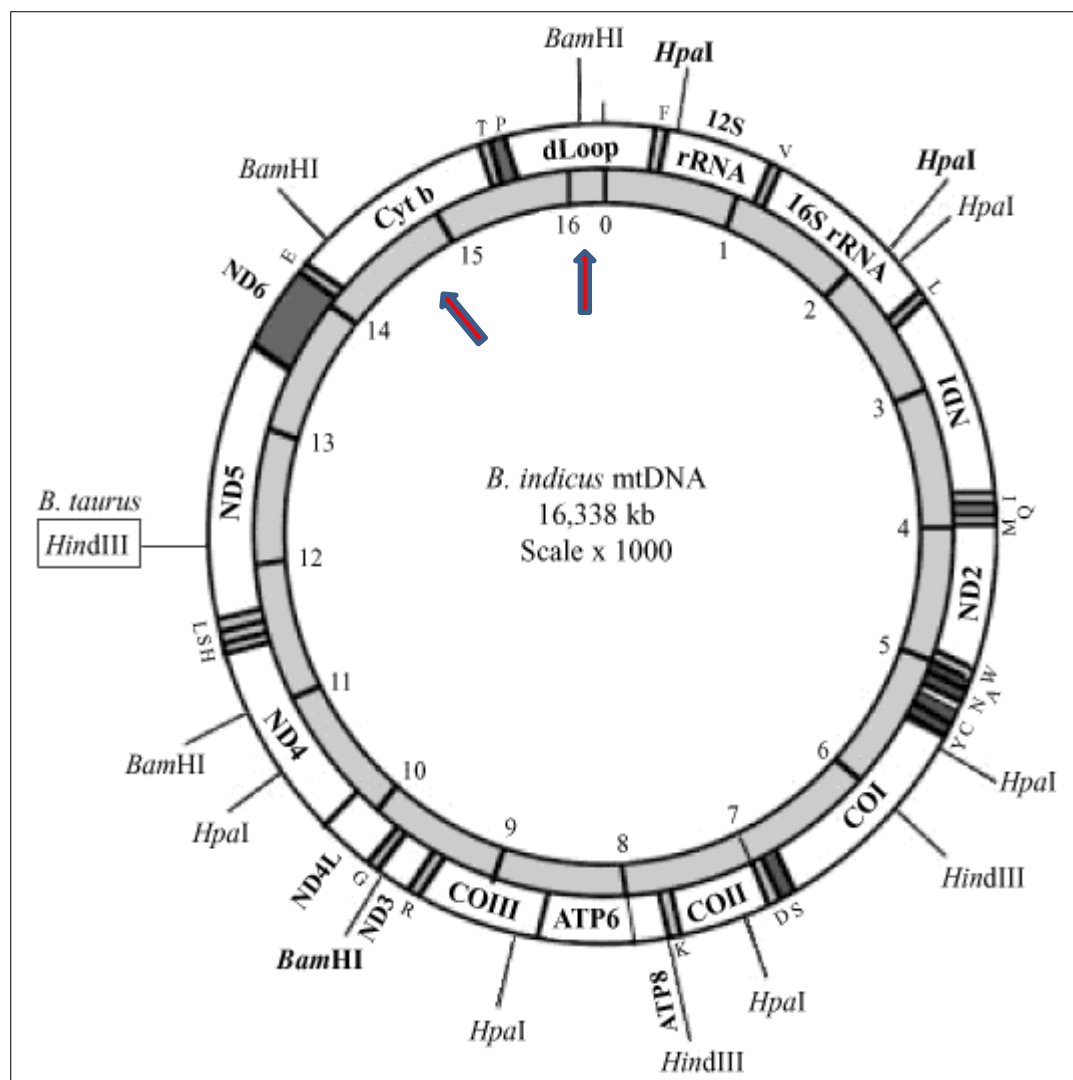

Figure 5.2: Genome-wide map of the bovine (Domestic cattle: *Bos indicus*) mitochondria showing the positions of the cytochrome-*b* gene, tRNA T and P, and control region/d-loop that were amplified in Bornean banteng in Sabah using four smaller overlapping fragments, which were used for analyses of the genetic structure and phylogeny (Meirelles et al., 1999). Note, in italics are sites found exclusively in *B. indicus* and (*HindIII*) in *B. taurus* mtDNA.

Amplification of mtDNA

DNA was amplified in 32 μ L (note, a large volume was required for forward and reverse sequencing) using QIAGEN Multiplex PCR kit® and 3 μ L of DNA extract, 0.75 μ g/ μ L of Bovine Serum Albumin (BSA), and 2 μ M of primer mix. PCR cycling conditions started with 95°C for 15 minutes followed by 94°C for 1 minute for DNA denaturation, primer annealing for 1 minute and 30 seconds at primer-specific melting temperature (T_m), followed by primer extension at 72°C for 1 minute and 30 seconds with a final extension at 72°C for 30 minutes. All PCRs were conducted using a Veriti 96 Well thermal cycler (Applied Biosystems®). Amplification success was tested using a 3% agarose gel electrophoresis at 120 volts/30 mins

that was stained with ethidium bromide fluorescence. Gels were imaged using a UVP GelDoc-It™ Imaging System. A total of four PCRs were conducted for each sample. In all PCRs at least one negative control was used; if contamination (a positive result in the negative control) was observed the PCR would be repeated. If one fragment failed to amplify then the PCR would be repeated at least four times using 4µL of DNA to allow successful amplification. PCR products were sequenced using an ABI PRISM 377 automated sequencer using Eurofins Genomics (Germany), and each fragment was sequenced in both forward and reverse direction to confirm authenticity. Eight sequences were obtained per sample. Each fragment sequence was checked by eye, aligned (with overlap) and merged using Sequencher 5.2.4 to obtain one continuous sequence for each sample. The consensus sequences were compared to the nucleotide database in GenBank using BLAST to confirm species identity.

Sexing markers

Direct observation of faecal deposition was not possible in the field therefore the sex of each faecal sample was determined using a molecular protocol. Two primers were used to determine the sex: S4BF (5'-CAAGTGCTGCAGAGGATGTGGAG-3') and S4BR (5'-GAGTGAGATTTCTGGATCATATGGCTACT-3') designed by Kageyama et al., (2004) *in* Riviere-Dobigny et al., (2009). The primers amplified two fragments: 178bp long male-specific fragment located throughout the long arm of the Y chromosome, and a 145bp long fragment which was found to amplify in both males and females (genes unknown) (Riviere-Dobigny et al., 2009). The PCR conditions were the same as for mtDNA fragment but using an annealing temperature of 58°C. Fragments were electrophoresed in 3% agarose gel as above. The PCR was replicated six times per sample to determine the sex of the sample. Success of amplification was scored according to three categories: male, female and failure to amplify.

5.3.3 Statistical analyses

Phylogeny

Phylogenetic reconstruction of the Bornean banteng and other related species included the two banteng subspecies (Javan and Burmese banteng) together with various closely related cattle species including gaur, kouprey (*B. sauveli*), aurochs (*B. primigenius*), and more distant species saola (*Pseudoryx ngtinghensis*), water buffalo (*Bubalus bubalis*) and an outgroup of a

more distance species, the domestic goat (*Capra hircus*). Sequences were retrieved from GenBank and exported as a FASTA file using BioEdit; accession numbers are available in Table 5.2. Phylogenies were created using two methods: 1) an approximation of the evolutionary distance between samples using a Neighbour-Joining (NJ) tree, and 2) a more robust Bayesian likelihood tree.

1) Neighbour joining tree

The NJ phylogeny was first inferred using a distance estimator based on nucleotide substitutions and 1,000 bootstraps (Saitou & Nei 1987), and constructed using MEGA 6 (Tamura et al., 2013). Rates of nucleotide substitutions across lineages were maintained as homogenous, and no absences in sequence data were permitted. The RelTime method and a specific time constraint approach (Hassanin & Ropiquet, 2004, 2007; Roos et al., 2008) were used to compute branch-specific relative rates (Tamura et al., 2012). One node that has only two decedents, the bison (*Bison bison bison*) and yak (*Bos grunniens*), and their divergence time (3.89 mya to 5.53 mya) (Hassanin & Ropiquet 2007; Hassanin & Ropiquet 2004) were used to parameterise the phylogeny. This approach was favoured over a standard molecular clock of 2% per mya for mammalian mtDNA (Al et al., 2004) due to the complex domestication history of *Bos* which may have influenced and accelerated evolutionary change, and also favoured over the dates of ancient artefacts because records are scant.

2) Bayesian likelihood tree

The second phylogeny was recreated using a Bayesian Likelihood tree and Markov chain Monte Carlo (MCMC) method using MrBayes (Huelsenbeck et al., 2014). 1,000,000 generations were used to estimate convergence and determine the posterior probability of the final tree given the observed data (Holder & Lewis 2003). Three molecular clock models were tested using a stepping-stone approach with 255,000 generations (including 25% burn-in period) and the log likelihood of the harmonic means were compared (1: non-clock, which does not follow regular pattern of sequence evolution, 2: strict clock, follows a consistent pattern in sequence evolution, and 3: relaxed clock, which allows evolution of branches at different rates) to identify the best model fit that was then used to date the phylogeny. A clock-constrained analysis was selected for phylogeny construction, using the relaxed clock model and Independent Gamma Rates (IGR) (continuous uncorrelated rate variation across lineages) (Huelsenbeck et al., 2014; Ronquist et al., 2012). Prior clock parameters were specified as 3.89-5.53 mya divergence between bison and yak, the same as the NJ tree, with a

uniform distribution date (i.e. the chance of divergence throughout this specified time period was equal). Tree clock priors used to age the nodes of the tree were defined as 0.01 (the number of substitutions per site per million years) between pairwise estimates of banteng and gaur (0.023-0.008 MacEachern et al., 2009) with a (95%) standard deviation of 0.005. The diagnostic parameters of the target distribution were used to validate the phylogeny, including an assessment of the Potential Scale Reduction Factor (PSRF) and the Estimated Sample Size (ESS). PSRF is a convergence diagnostic that should be close to 1.0 if the number of generations provide a good sample of the posterior distribution (Ronquist et al., 2011). ESS is the degree of independent MCMC and should ideally exceed 100 if the number of generations is adequate.

Table 5.2: Sequences extracted from the database GenBank used to construct a phylogeny of the Bornean banteng. A total of nine species of *Bos* were included along with the Javan and Burma banteng. The fragment size amplified in the Bornean banteng was trimmed to include as many different species as possible. The outgroup domestic goat *Capra hircus* is indicated by *.

Species	Common name	Breed type/Location	GenBank Accession no.	Match (%)
<i>Bos javanicus lowi_H_1</i>	Bornean banteng	Sabah, Malaysia	Not submitted	n/a
<i>Bos javanicus lowi_H_2</i>	Bornean banteng	Sabah, Malaysia	Not submitted	n/a
<i>Bos javanicus lowi_H_3</i>	Bornean banteng	Sabah, Malaysia	Not submitted	n/a
<i>Bos javanicus lowi_H_4</i>	Bornean banteng	Sabah, Malaysia	Not submitted	n/a
<i>Bos javanicus lowi_H_5</i>	Bornean banteng	Sabah, Malaysia	Not submitted	n/a
<i>Bos javanicus lowi_H_6</i>	Bornean banteng	Sabah, Malaysia	Not submitted	n/a
<i>Bos gaurus (b)</i>	Gaur	Cambodia	JN632604.1	99
<i>Bos gaurus (a)</i>	Gaur	Thailand	GU324987	98
<i>Bos sauveli</i>	Kouprey	n/a	AY689189.1	96
<i>Bos javanicus birmanicus (a)</i>	Burma Banteng	Cambodia	EF685913	95
<i>Bos javanicus birmanicus (b)</i>	Burma Banteng	Cambodia Captive/CERZA Zoo	EF685912	95
<i>Bos javanicus javanicus</i>	Javan Banteng	France	AY689188	95
<i>Bos grunniens</i>	Domestic Yak	Tibetan Area	KM233416.1	91
<i>Bos taurus</i>	Taurine cattle	Mongolia	FJ971088.1	90
<i>Bos taurus indicus</i>	Zebu	Zebu/Tibetan Plateau (Ankole-Watusi - Africa)	GU256940.1	90
<i>Bos taurus primigenius</i>	Auroch		EU747737.1	90
<i>Bison bison bison</i>	Bison	North America	JPYT01158469.1	
<i>Bubalus bubalis</i>	Water buffalo	India	AF547270.1	84
<i>Pseudoryx nghetinhensis</i>	Saola	n/a	EF536352.1	83
<i>Capra hircus</i>	Domestic goat*	n/a	NC005044	83

Comparison with Bornean Banteng from GenBank

Four short sequences of *B. j. lowi* from Sabah were recently submitted to GenBank by Matsubayashi et al., (2014) and included two haplotypes of partial cytochrome-*b* gene sequences (accession numbers AB703046 and AB703047) of fragment length 227bp and two haplotypes of partial control region/d-loop (accession numbers AB703048 and AB703049) of fragment length 253bp. Alignment of these short sequences with my sequences confirmed one new haplotype in cytochrome-*b* gene not sampled during the present study, distinguished by one substitution in position 70bp (AB703047), and one haplotype in control region/d-loop also not sampled during this study, distinguished by one substitution in position 99bp (AB703048). At this position, I observed a smaller peak in some of my samples that was analogous to the one nucleotide base used to distinguish the two haplotypes in the study by Matsubayashi et al., (2014). Analysis using these sequences was not conducted however, due to their short length which restricts the ability to detect nucleotide substitutions; these sequences were therefore not included in the final data set.

Data preparation for analysis of genetic diversity

Samples were collected blindly without knowledge of the individual, therefore there is the possibility that some individuals were sampled several times, while others might have been sampled only once. MtDNA is unable to discriminate different individuals. As part of this study, 23 microsatellite markers (Appendix 5.3) were tested to identify optimum annealing temperatures (Appendix 5.4). A protocol to multiplex 13 microsatellites was designed (see Appendix 5.5) to distinguish individuals and estimate genetic diversity using the nuclear genome; however, low amplification success prevented consistent results across samples therefore I was unable to include this work in the analyses.

It is not possible to distinguish individuals based solely on mtDNA, therefore microsatellite markers of nuclear DNA are widely used to validate the identity of each sequence. Prior to statistical analyses, multiple sequences from the same individual are removed for if they are retained they will cause error in statistical tests that are based on frequencies (i.e. pairwise genetic differences), which then gives rise to inaccurate results and misinterpretation. My data set potentially contained multiple sequences from the same individual due to the nature of sample collection. Microsatellite data was not available on this occasion, however I accounted for the above issues by analysing the data according to three scenarios:

- Scenario 1: Each sequence was treated as a separate individual according to their forest of origin (n=49).
- Scenario 2: Each sequence was treated as a separate individual according to their herd and forest of origin (n=49).
- Scenario 3: (*Reduced bias*) duplicate sequences of the same sex, haplotype, herd and forest were removed (n=21, Appendix 5.6).

The forest of origin for each sample was recorded at the time of sample location, and then checked using a boundaries map of the forests of Sabah in ArcMap 10.0 (ESRI 2014). The locations of each herd were based on GPS coordinates of photographic captures of banteng and recapture histories of individuals from camera traps (Chapter 4), and faecal samples were assigned to a herd based on their GPS location. Herds were assumed to be independent from each other as inter-herd mixing of individuals was never observed using camera traps. These scenarios essentially resulted in three different data sets that were used for analysis, which allowed me to maximise the potential of the data, account for the sampling issue, and gauge the effect of the multiple sampling of individuals upon statistical results.

Genetic diversity and population structure

Genetic diversity was estimated by nucleotide diversity (π) and haplotype diversity (H_d) using DnaSP 5.10.02 (Rozas et al., 2010). Genetic differentiation between sites was estimated using F_{ST} , based on haplotype differences between sites, estimated using Arlequin version 3.5.1.3 (Excoffier & Lischer 2011). To visualise the relationship between haplotypes, sampling locations and herds, a median-joining network was constructed using NETWORK 4.6.1.2 (Polzin & Daneshman 2004). Differences between sites in haplotypes were visualised using Quantum GIS 2.6.1 (Development Team 2012).

To investigate the population structure, I conducted two analyses of molecular variance (AMOVA) using Arlequin version 3.5.1.3 (Excoffier & Lischer 2011). The first AMOVA used scenario 2 (all sequences categorised according to herds and forests) and the second used scenario 3 (duplicates of each sex removed). AMOVA assessed how genetic variation was partitioned among forests, among herds within forests, and within herds. A correlation between genetic divergence and geographic distance was evaluated with a Mantel test conducted using Alleles in Space (AIS) 1.0 (Miller 2005). When there is a close relationship between two sequences, a Mantel test correlation coefficient (r) will be vary between 0 and 1,

and when there is no relationship it will vary between 0 and -1. Significance was assessed using 10,000 resampling permutations. To permit inferences to be made about spatial scales over which the genetic structure occurs, an autocorrelation analysis was conducted using Alleles in Space. In this analysis, the average genetic distance between individuals (A_y) was estimated per distance class, using 10 classes of 20km intervals. A_y varies between zero and one, whereby a positive value of 1 indicates all individuals genetically identical and a value close to zero indicates there is no relationship between individuals (Miller 2005).

Three statistics were used to investigate the Bornean banteng demographic history: 1) mismatch distribution, 2) Tajima's D , and 3) Fu's D , that were all conducted in Arlequin v 3.5.1.3 (Excoffier & Lischer 2011). The goodness of fit of the observed mismatch distribution to that expected under the sudden population expansion model was tested using the sum of squared deviations (SSD) and Harpending's raggedness index (HRI) and 10,000 permutations to obtain confidence intervals (Excoffier & Lischer 2011). Selective neutrality tests based on the allele frequency spectrum are used to identify signatures of selection but are also sensitive to demographic changes. I estimated Tajima's D and Fu's F_S to assess whether the observed data deviated from a demographically stable model. Significance of these tests was assessed with 10,000 bootstraps. A signature of population expansion can be identified when these two statistics present significant negative values (Wangenstein et al., 2012).

5.4 Results

5.4.1 Sampling

Eighty-six faecal samples were collected: 45 from Tabin Wildlife Reserve (TWR), six from Ulu-Segama Malua Forest Reserve (USMFR), 19 from Malua Forest Reserve (MFR) and 16 from Maliau Basin Conservation Area (MBCA). Five samples were excluded from DNA extraction and amplification due to advanced decomposition.

5.4.2 Amplification success of markers

mtDNA

Forty-nine samples were amplified (TWR: 20, USMFR: 5, MFR: 8, MBCA: 16) and successfully sequenced in all four overlapping fragments. For some herds it was only possible to collect one sample due to the availability of fresh faeces. Based on the assumption that each sequence was a different individual, I obtained 20 sequences which originated from TWR; herd 1 (12), herd 2 (6), herd 3 (1), herd 4 (1), 5 sequences from USMFR; herd 5 (5), 8 sequences from MFR; herd 6 (3), herd 7 (5), and 16 sequences from MBCA; herd 8 (16). Blast searching against the GenBank database identified a match of 99% with gaur from Cambodia (accession number JQ404408.1), which is considered the closest related *Bos* species to banteng followed by the now extinct aurochs (*B. primigenius*: accession number EU747737.1), kouprey (accession number AY689189.1), and yak (accession number KM233416.1). Following confirmation of the correct target species, sequences were trimmed to obtain a sequence length that was analogous in all samples. The consensus total fragment length was 1,368bp and this included partial cytochrome-*b* gene, complete tRNA, and partial control region/d-loop. The nucleotide composition included C (23.61%), T (16.67%), A (34.72%), G (25%).

Sex-determination

Seventy-five samples were sexed: 51 male and 24 female (Appendix 5.7). Assuming each sample was one individual, in TWR there were 25 males and 12 females; herd 1 comprised: 4 females and 20 males, herd 2 comprised: 6 females and 2 males, herd 3 comprised: 1 male, herd 4 comprised: 1 male (note, herds 3 & 4 are believed to contain more individuals but only one sample for each herd was available for collection). In USMFR herd 5 comprised: 6 males. In MFR 10 females and 6 males were determined; herd 6 comprised: 3 females and 3 males, herd 7 comprised: 6 females and 3 males. In MBCA 14 males and 2 females were determined and comprised herd 8.

5.4.3 Phylogeny of ancestral maternal lineage

Neighbour-joining (NJ) analysis

The original NJ tree found support for the phylogenetic relationships that exceeded >63% in all clades in Figure 5.3. The phylogeny identified a coalescence of all banteng lineages,

which also included gaur and kouprey that dated to approximately 1.8 mya. Bornean banteng shared a separate clade with gaur with a divergence at 310 kya. The six ancestral haplotypes of Bornean banteng diverged approximately 50 kya. My divergence time between Bornean banteng and gaur from mainland Southeast Asia was comparable with the approximate divergence time of the Bornean and Sumatran Sunda clouded leopard (*Neofelis diardi*), which was estimated around 331 kya (95% CI: 60-640 kya) (Wilting et al., 2011).

Bayesian likelihood analysis

Stepping-stone analysis and comparison of harmonic means identified strong support for a relaxed molecular clock, by a log difference exceeding 10. The effective sample size (i.e. number of independent simulations required for a robust phylogeny) (ESS: >300) gave strong support for 1,000,000 MCMC generations, that reached convergence (PSRF: 1.0-1.002) with no correlation pattern evident in the chains plot. Essentially the Bayesian analysis produced a phylogeny with the topology that was comparable with the neighbour-joining tree (Figure 5.4). The grouping of species formed two distinct clades comprising (Clade A) water buffalo (*B. bubalis*) and saola (*P. nghetinhensis*) and (Clade B) Bos and bison (*B. b. bison*). The Bayesian posterior probability for the position of nodes was relatively high for Clade A (53% \pm 0%), and very high for Clade B (72-100% \pm 1%). As with the NJ tree, the Bornean banteng shared a sister clade with gaur and had high probability (100% \pm 0%) to support its cluster. The time of divergence between Bornean banteng and gaur was estimated to be relatively recent (between 217 to 634 kya) compared to the Burma banteng (*B. j. birmanicus*) and kouprey (*B. sauveli*) (333 to 941 kya) and Javan banteng (*B. j. javanicus*) (1.479 to 2.743 mya). Divergence between the six banteng haplotypes was estimated to be between 55 to 355 kya, with a more recent divergence time between H_1 and H_2 that dated between 10 years to 70 kya.

5.4.4 Population genetic diversity and structure

Haplotypes

Six haplotypes were found. The six haplotypes were distinguished by eight polymorphic sites that occurred at the following positions in relation to the complete genome on gaur (accession number: JN632604.1): 14716, 15037, 15142, 15173, 15403, 15711 and 15715, and comprising five transitions and three transversions. Haplotypes 2, 4, 5 and 6 can be distinguished by two substitutions at positions 15172 bp and 15173 bp, one substitution at

14716 bp, one substitution at position 15711 bp, and one substitution at 15037 bp, respectively.

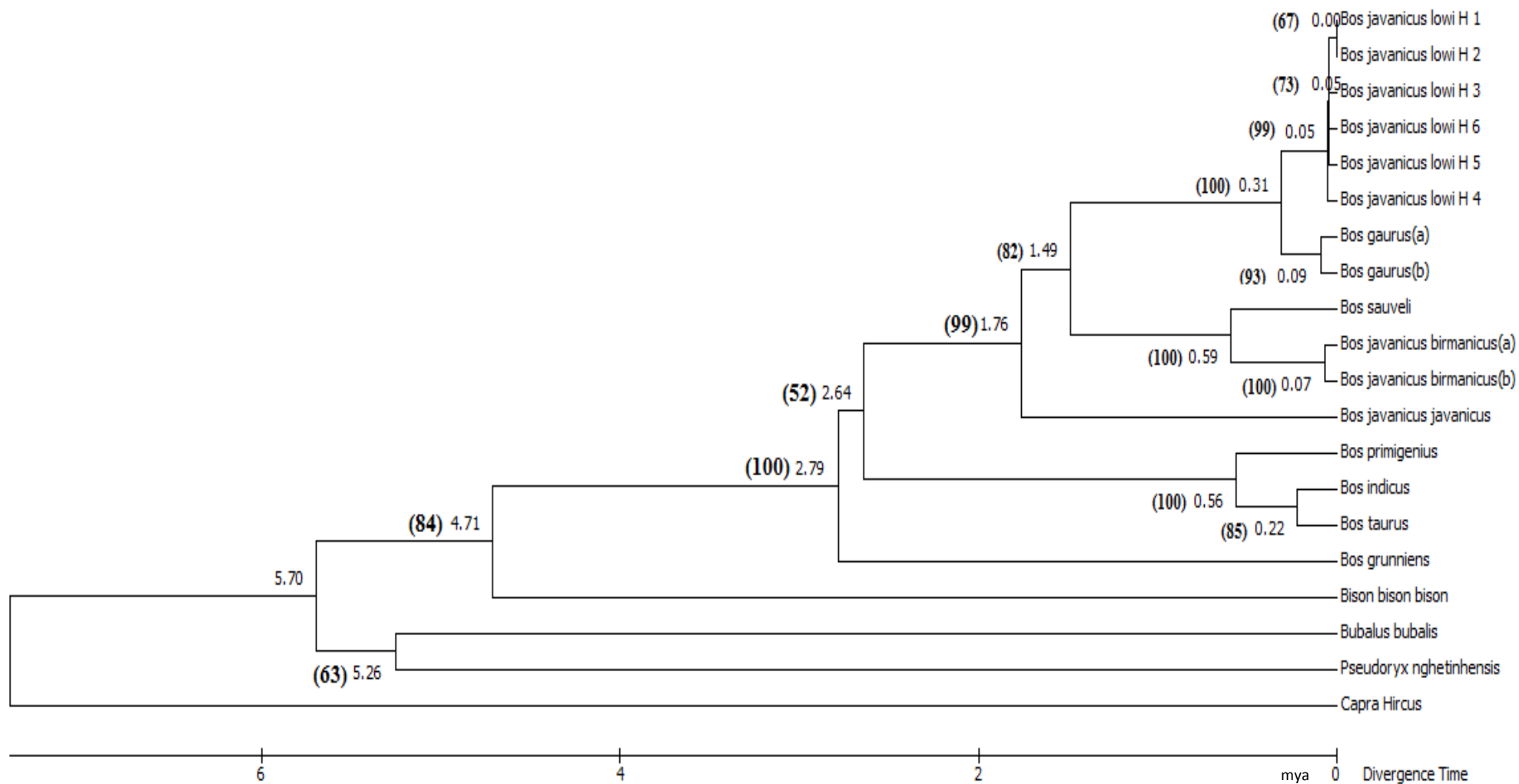

Figure 5.3: The evolutionary history of *Bos* using the Neighbour-Joining method constructed in MEGA 6.0 based on 1,000 bootstraps to estimate percentage confidence of clades (in brackets), which were high for banteng (>67%) and supported the clade position and branch length. Divergence times for all branching points in the topology (located next to the confidence of clades but not in brackets) were calculated with the RelTime method using the branch lengths contained in the inferred tree and one calibration point ranging between minimum 3.89 mya and maximum divergence time 5.53 mya between bison (*B. b. bison*) and yak (*B. grunniens*) (Hassanin & Ropiquet 2007; Hassanin & Ropiquet 2004). The analysis involved 20 nucleotide sequences, with nine species of *Bos* and all three subspecies of banteng, including the six haplotypes identified by this study and an outgroup of goat (*Capra hircus*). All positions containing gaps and missing data were eliminated. There were a total of 938 positions in the final dataset. *Bos gaurus* (a): Thailand, (b): Cambodia, *Bos javanicus javanicus* (a & b): Two haplotypes from Cambodia.

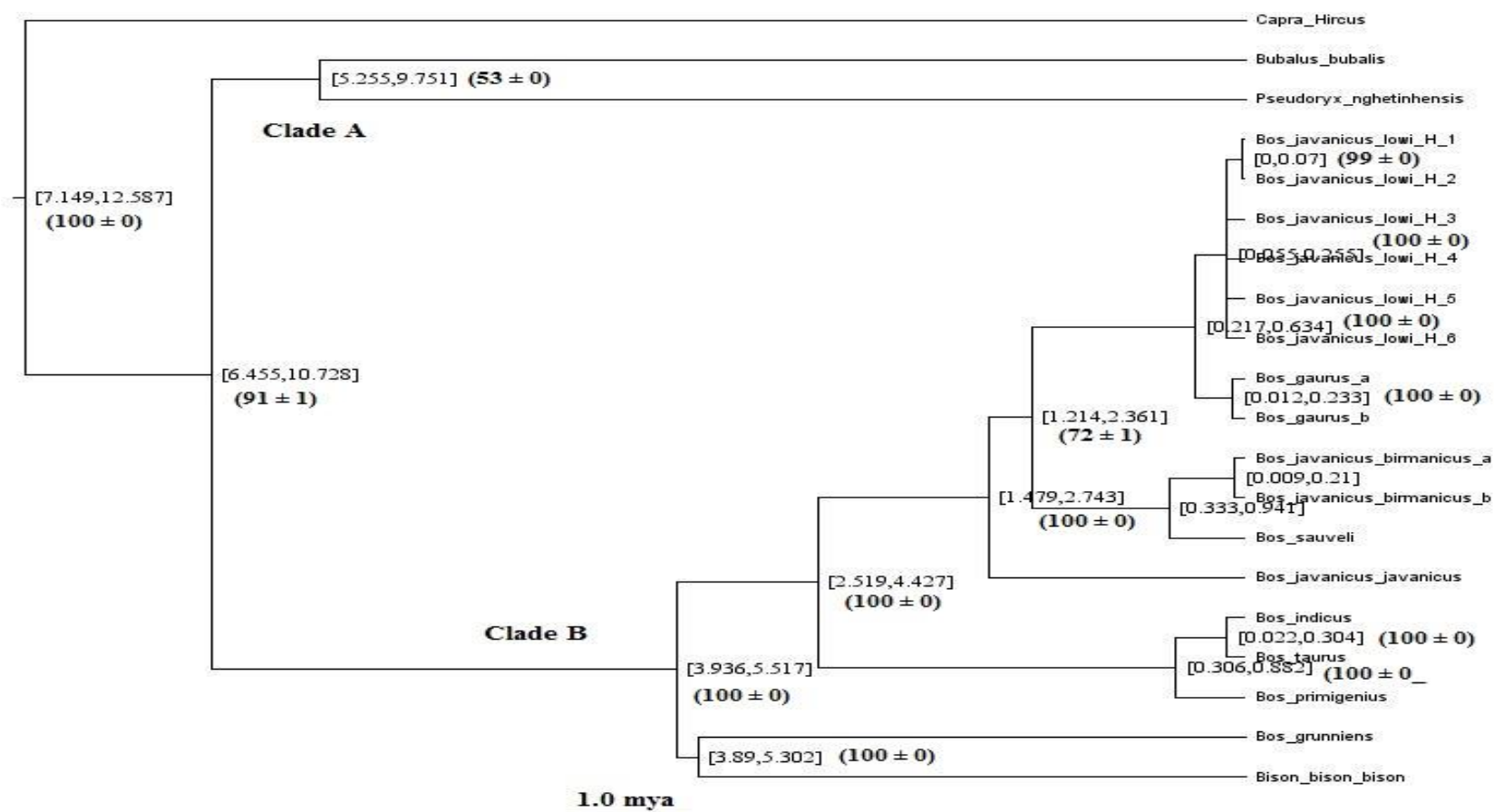

Figure 5.4: The evolutionary history of *Bos* using the Bayesian method based on 1,000,000 generations of Markov Monte Carlo chains (MCMC) constructed in MrBayes. Molecular dating of the tree was conducted using a relaxed clock assumption with tree clock priors ($0.001 \pm 95\%$ CI 0.005) and a divergence date of 3.89–5.53 mya between bison (*B. bison bison*) and yak (*B. grunniens*) (Hassanin & Ropiquet 2007; Hassanin & Ropiquet 2004) with a scale of divergence of one million years (mya). Confidence of the clusters is illustrated as percentage probabilities in brackets next to divergence times. The Bayesian posterior probability values for each of the branches was strong (72–100%) for all species, including banteng (99–100% for *B. j. lowi* nodes) and slightly lower (52%) for the outgroup water buffalo (*Bubalus bubalis*) and saola (*Pseudoryx nghetinhensis*). The analysis involved 20 nucleotide sequences, with nine species of *Bos* and all three subspecies of banteng, including the six haplotypes identified by this study and the outgroup domestic goat (*Capra hircus*). All positions containing gaps and missing data were eliminated, and a total of 938 positions were included in the final dataset. Phylogeny by David Stanton.

The median-joining network constructed to describe the relationship between the six haplotypes using all sequences obtained (Figure 5.5) had a prominent star-shaped pattern that comprised two higher frequency haplotypes (H_1 and H_3) and four rare haplotypes (H_2, H_4, H_5 and H_6) which diverged by one and four substitutions, respectively, from the most common haplotype H_1. This star-shape is typical of populations that have undergone a recent demographic expansion (Slatkin & Richard 1991). The most common haplotype (H_1) was represented by 26 sequences, and H_3 was represented by 18 sequences and were present in all four forests. The least frequent haplotypes (only seen in one sample) were H_2 and H_4 found in Tabin Wildlife Reserve, and H_5 and H_6 found in Malua Forest Reserve. A map constructed using the frequencies of haplotypes according to scenario 1 (Figure 5.6) shows a near homogenous distribution of these haplotypes across the Sabah landscape, with the exception of four low-frequency alleles, which were clustered in central Malua Forest Reserve (2) and the west border of Tabin Wildlife Reserve (2).

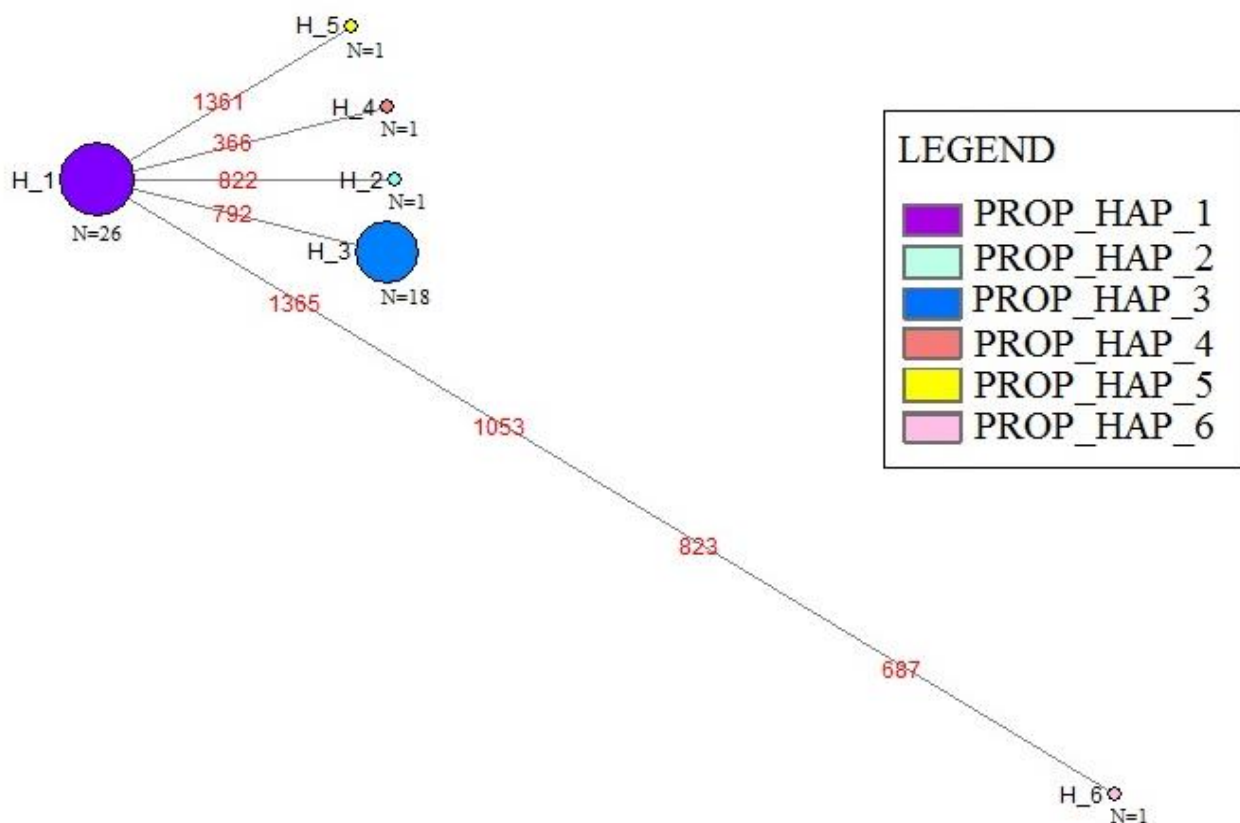

Figure 5.5: A median-joining network identified six distinct haplogroups (H_1 to H_6) in Bornean banteng in Sabah, with a prominent star-shaped phylogeny indicative of population expansion. The network was created using $n=49$ sequences and a fragment length of 1,368bp, covering mtDNA partial cytochrome-*b* gene, tRNA and partial d-loop. Sequences were from four forests in Sabah: Tabin Wildlife Reserve (TWR), Ulu-Segama Malua Forest Reserve (USMFR), Malua Forest Reserve (MFR) and Maliau Basin Conservation Area (MBCA) and the size of the haplogroup is directly proportional to the number of sequences.

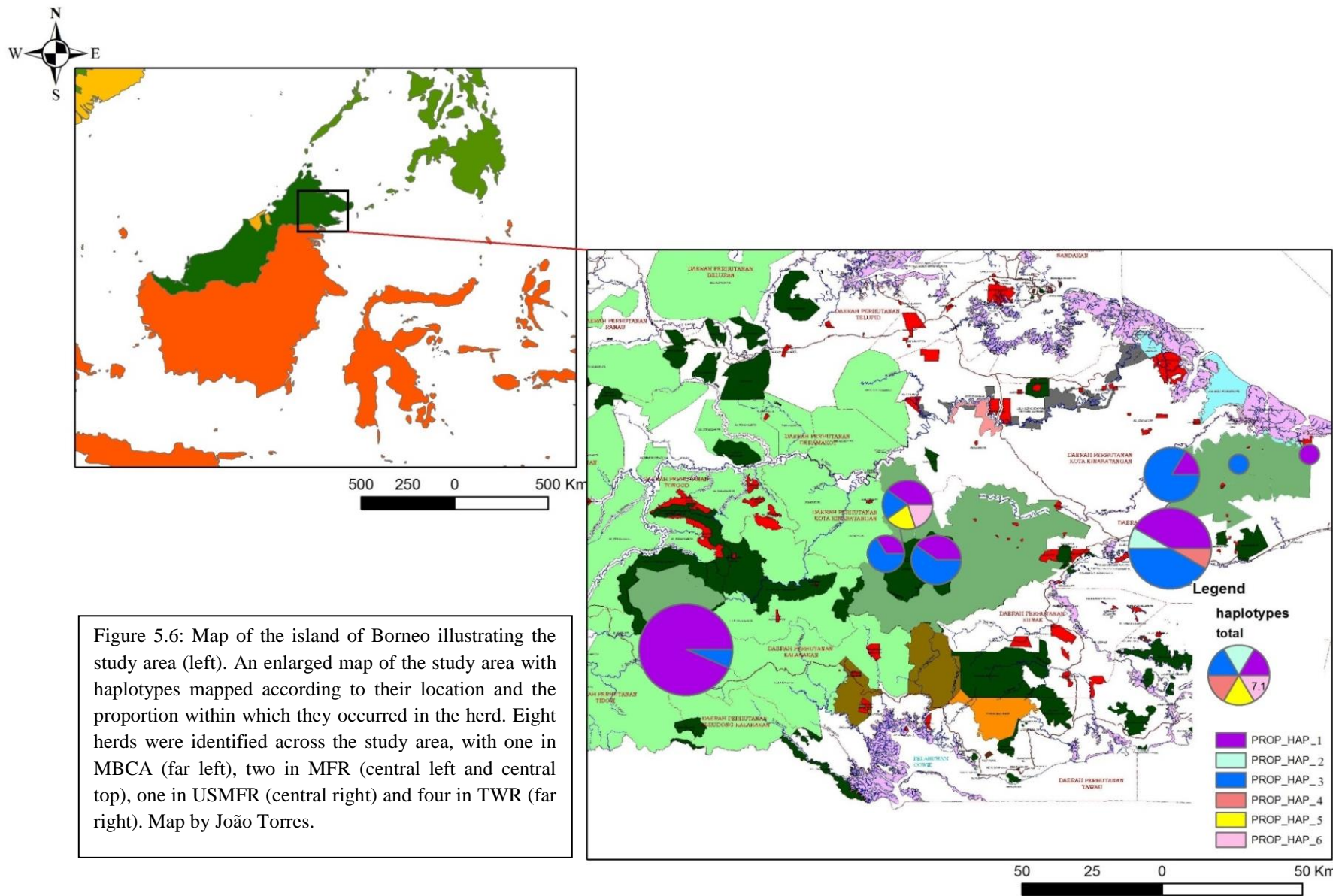

Figure 5.6: Map of the island of Borneo illustrating the study area (left). An enlarged map of the study area with haplotypes mapped according to their location and the proportion within which they occurred in the herd. Eight herds were identified across the study area, with one in MBCA (far left), two in MFR (central left and central top), one in USMFR (central right) and four in TWR (far right). Map by João Torres.

Genetic diversity accounting for sampling bias

Scenario 1: Each sequence was treated as a separate individual according to their forest of origin (n=49).

Three forests had high haplotype diversity: Malua Forest Reserve (H_d : 0.75), Tabin Wildlife Reserve (H_d : 0.60) and Ulu-Segama Malua Forest Reserve (H_d : 0.60) but low nucleotide diversity (π : 0.00054, π : 0.00122 and π : 0.00045, respectively). Maliau Basin Conservation Area had the lowest haplotype diversity (H_d : 0.13) and also very low nucleotide diversity (π : 0.00009). When forests were pooled, the haplotype diversity (H_d) for all forests (n=49) was relatively high (H_d : 0.56) however nucleotide diversity (π) remained low (π : 0.00056) (Table 5.3).

Scenario 2: Each sequence was treated as a separate individual according to their herd and forest of origin (n=49).

Sequences were assigned to one of eight herds: four in Tabin Wildlife Reserve (two on the west border, one central and one in the east border), one in Ulu-Segama Malua Forest Reserve, two in Malua Forest Reserve (one in the south and one in the central region), and one in Maliau Basin Conservation Area (a conservative estimate based on limited recapture data available at the time of analyses). Haplotype diversity and nucleotide were highest for herd 7 in Malua Forest Reserve (H_d : 0.697, π : 0.002) with a sample size of five sequences (Table 5.3), followed by herd 1 in Tabin Wildlife Reserve (H_d : 0.697, π : 0.001) using 12 sequences, and herd 6 in Malua Forest Reserve using 3 sequences (H_d : 0.667, π : <0.001). Haplotype diversity and nucleotide diversity were lowest for Maliau Basin Conservation Area (H_d : 0.133, π : <0.001) which had a sample size of 15 sequences.

Scenario 3: (Reduced bias) duplicate sequences of the same sex, haplotype, herd and forest were removed (n=21).

For herds that contained a single haplotype (herd 3 and herd 4) in the central and eastern areas of Tabin, the diversity parameters could not be estimated. Haplotype diversity was high in herds 5 in Ulu-Segama Malua Forest Reserve, 6 and 7 in Malua Forest Reserve (H_d : 1.0, π : 0.001) but only because sample sizes were small (2, 2, and 4, respectively) (Table 5.3). In Tabin, herds 1 and 2 had high haplotype diversity (H_d : 0.900 and 0.667, π : 0.001 and π : <0.001, respectively).

Table 5.3: Parameters of gene flow and genetic differentiation between sampling locations in Tabin Wildlife Reserve (TWR), Ulu-Segama Malua Forest Reserve (USMFR), Malua Forest Reserve (MFR) and Maliau Basin Conservation Area (MBCA) according to three different scenarios: 1) sequences sorted according to forest of origin, 2) Sequences sorted to herd and forest of origin, and 3) sequences sorted to herd and forest of origin with duplicate sexes removed to reduce error associated with sampling bias. Genetic diversity reported as haplotype diversity (H_d) and nucleotide diversity (π). Demographic history of banteng was tested using three statistics to investigate population expansion against hypotheses of neutral/stable population, sudden population expansion and the mismatch distribution.

Scenario	Sampling site	Sample size	No. polymorphic sites	Genetic diversity			Neutrality tests			Mismatch distribution						
				No. haplotypes	Haplotype diversity (H_d)	Nucleotide diversity	K: av. No. differences	Tajima's D	p -value	Fu's F_s	p -value	SSD	HRI	p -value		
Scenario 1: Forest of origin	TWR	20	3	4	0.600	0.000	0.721									
	USMFR	5	1	2	0.600	0.000	0.600									
	MFR	8	6	4	0.786	0.001	1.786									
	MBCA	16	1	2	0.600	0.000	0.133									
	All populations	49	8	6	0.576	0.001	0.770	-1.574	<0.05	-1.881	ns	0.027	0.195	<0.05		
Scenario 2: Herd and forest of origin	TWR	Herd 1	12	3	4	0.697	0.001	0.864								
		Herd 2	6	1	2	0.333	0.000	0.333								
		Herd 3	1	n/a	1	n/a	n/a	n/a								
		Herd 4	1	n/a	1	n/a	n/a	n/a								
	USMFR	Herd 5	5	1	2	0.600	0.000	0.600								
		Herd 6	3	1	2	0.667	0.000	0.667								
		Herd 7	5	6	4	0.900	0.002	2.400								
	MBCA	Herd 8	16	1	2	0.133	0.000	0.133								
	All populations	49	8	6	0.579	0.001	0.781	n/a	n/a	n/a	n/a	n/a	n/a	n/a	n/a	
Scenario 3: Duplicates removed	TWR	Herd 1	5	3	4	0.900	0.001	1.400								
		Herd 2	3	1	2	0.667	0.000	0.667								
		Herd 3	1	n/a	1	n/a	n/a	n/a								
		Herd 4	1	n/a	1	n/a	n/a	n/a								
	USMFR	Herd 5	2	1	2	1.000	0.001	1.000								
		Herd 6	2	1	2	1.000	0.001	1.000								
	MFR	Herd 7	4	6	4	1.000	0.001	1.400								
		Herd 8	3	1	2	0.667	0.000	0.667								
	All populations	21	8	6	0.713	0.001	1.251	-1.558	<0.05	-1.680	ns	0.020	0.147	ns		

Population structure

The analysis of molecular variance (AMOVA) revealed that when all sequences were assumed to be a different individual but were sorted according to the herd and forest of origin (scenario 2), most of the variation occurred was contained within herds (82.25%, $p < 0.05$) rather than among forests (5.28%, non-significant) or among herds within forests (12.46%, non-significant). When potential duplicate sequences were removed (scenario 3), the data set comprised a small number of individuals ($n=21$) that did not result in significant genetic variation between the three hierarchical categories, and this may be due to reduced statistical power when using few samples.

Table 5.4: Analysis of molecular variance (AMOVA) of banteng in Sabah, using two scenarios to account for bias when including repeated sampling of individuals. Degrees of freedom (d.f.), significance of relationship (p-value). Greater genetic variation (82%, $p < 0.05$) was explained within herds when including all sequences from all forests ($n=49$). Forest only explained a small amount of genetic variation in scenario 2 & 3 (5.3% and 2.2%,

Hierarchal levels	d.f	Mean sum of squares	Variance components	Percentage of variation	p-value
Scenario 2: forests (4) and herds (8)					
Among forests	3	2.871	0.02117	5.28	0.46
Among herds within forests	4	2.05	0.04994	12.46	0.38
Within herds	40	13.183	0.32958	82.25	<0.05
Total	47	18.104	0.4007		
Scenario 3: forests (4) and herds (8) with reps excluded					
Among forests	3	0.843	0.0126	2.2	0.54
Among herds within forests	4	1.333	-0.17986	-31.35	1.0
Within herds	13	9.633	0.74103	129.15	0.99
Total	20	11.81	0.57376		

Pairwise comparisons of haplotypes

Significant genetic differentiation was found between Maliau Basin Conservation Area (MBCA) and Malua Forest Reserve (MFR) (F_{ST} : 0.136, $p < 0.001$), between MBCA and Tabin Wildlife Reserve (TWR) (F_{ST} : 0.309, $p < 0.05$), and between Ulu-Segama Malua (USMFR) and MBCA (F_{ST} : 0.516, $p < 0.05$) based on pairwise genetic differences between haplotypes, 1,000 permutations and sequences grouped according with scenario 1 (Table 5.5).

When sorting sequences according to herds within each forest (scenario 2: Table 5.5), herd 2 in TWR and herd 7 in MFR are genetically differentiated (F_{ST} : 0.229, $p < 0.05$) as well as herds 1 in TWR and 8 in MBCA (F_{ST} : 0.184, $p < 0.05$), between 8 in MBCA and 6 in MFR, and lastly a strong significant difference between herd 2 in TWR and herd 8 in MBCA (F_{ST} : 0.753, $p < 0.001$). There were no significant differences between sites when duplicates of the same sex, haplotype, herd and forest were removed (scenario 3: Table 5.5).

Geographic and genetic distance

The Mantel test, for association between genetic and geographical distances for the grouping of samples in either herds or forests, resulted in a negative r coefficient (r : -0.187), albeit not significant. A second Mantel test conducted on the reduced bias (scenario 3) data set remained non-significant with no relationship between genetic distance and geographical distance of individuals when potential duplicated genotypes were removed (r : -0.0535, non-significant). Autocorrelation analysis did not identify a relationship between geographic distance and genetic distance using 10,000 random permutations (A_y: 0.691, p : 0.47). In all 10 distance classes the individuals were estimated to be genetically similar (A_y: 0.55-0.85).

Demographic history

Investigations of demographic history identified significant differences between the observed and expected (simulated) mismatch distributions under a scenario of sudden population expansion when all samples from all forests were included (SSD: 0.027, HRI: 0.195, $p < 0.05$: Figure 5.7). When all possible duplicates were removed and the test was re-ran there was no significant deviation from the sudden population expansion model (SSD: 0.02, HRI: 0.147 non-significant, Table 5.3).

Deviation from neutrality was estimated using Tajima's D statistic and scenario 1, whereby all samples were included in the analysis ($n=49$), and scenario 3 with no replicate samples

(n=21). Tajima's D statistic indicated significant deviations from neutrality (scenario 1: Tajima's D: -1.574, $p < 0.05$, and scenario 3: Tajima's D: -1.558, $p < 0.05$: Table 5.3) suggesting population expansion had occurred independently of the sequence sorting scheme.

Table 5.5: Pairwise genetic differences (F_{ST}) of banteng in Sabah between haplotypes calculated according to each forest (scenario 1: top), according to herds within each forest (scenario 2: middle) and according to forest and herd with duplicates removed (scenario 3: bottom). Significance of the pairwise relationships was tested using 1,000 permutations.

Scenario 1: forests (4)				
Forest	MFR	TWR	MBCA	USMFR
MFR	0	0	0	0
TWR	0.025	0	0	0
MBCA	0.136**	0.309**	0	0
USMFR	-0.072	-0.129	0.516*	0

Scenario 2: forests (4) and herds (8)									
Forest		Herd 1	Herd 2	Herd 3	Herd 4	Herd 5	Herd 6	Herd 7	Herd 8
	Herd 1	0	0	0	0	0	0	0	0
TWR	Herd 2	0.126	0	0	0	0	0	0	0
	Herd 3	-0.152	-1.000	0	0	0	0	0	0
	Herd 4	-0.481	0.600	1	0	0	0	0	0
	USMFR	Herd 5	-0.089	-0.067	-0.500	0	0	0	0
MFR	Herd 6	-0.132	-0.227	-1.000	0	-0.350	0	0	0
	Herd 7	0.059	0.229.	-0.333	-1.000	0.038	-0.039	0	0
MBCA	Herd 8	0.184*	0.753***	0.857	-1.000	0.516	0.616*	0.173	0

Scenario 3: (reduced bias) forests (4) and herds (8)									
Forest		Herd 1	Herd 2	Herd 3	Herd 4	Herd 5	Herd 6	Herd 7	Herd 8
	Herd 1	0							
TWR	Herd 2	-0.157	0	0	0	0	0	0	0
	Herd 3	-0.400	-1.000	0	0	0	0	0	0
	Herd 4	-0.750	0.000	1.000	0	0	0	0	0
	USMFR	Herd 5	-0.392	-0.615	-1.000	-1.000	0	0	0
MFR	Herd 6	-0.392	-0.615	-1.000	-1.000	-1.000	0	0	0
	Herd 7	-0.027	-0.060	-0.500	-1.000	-0.290	-0.290	0	0
MBCA	Herd 8	-0.240	-0.200	0.000	-1.000	-0.615	-0.615	-0.159	0

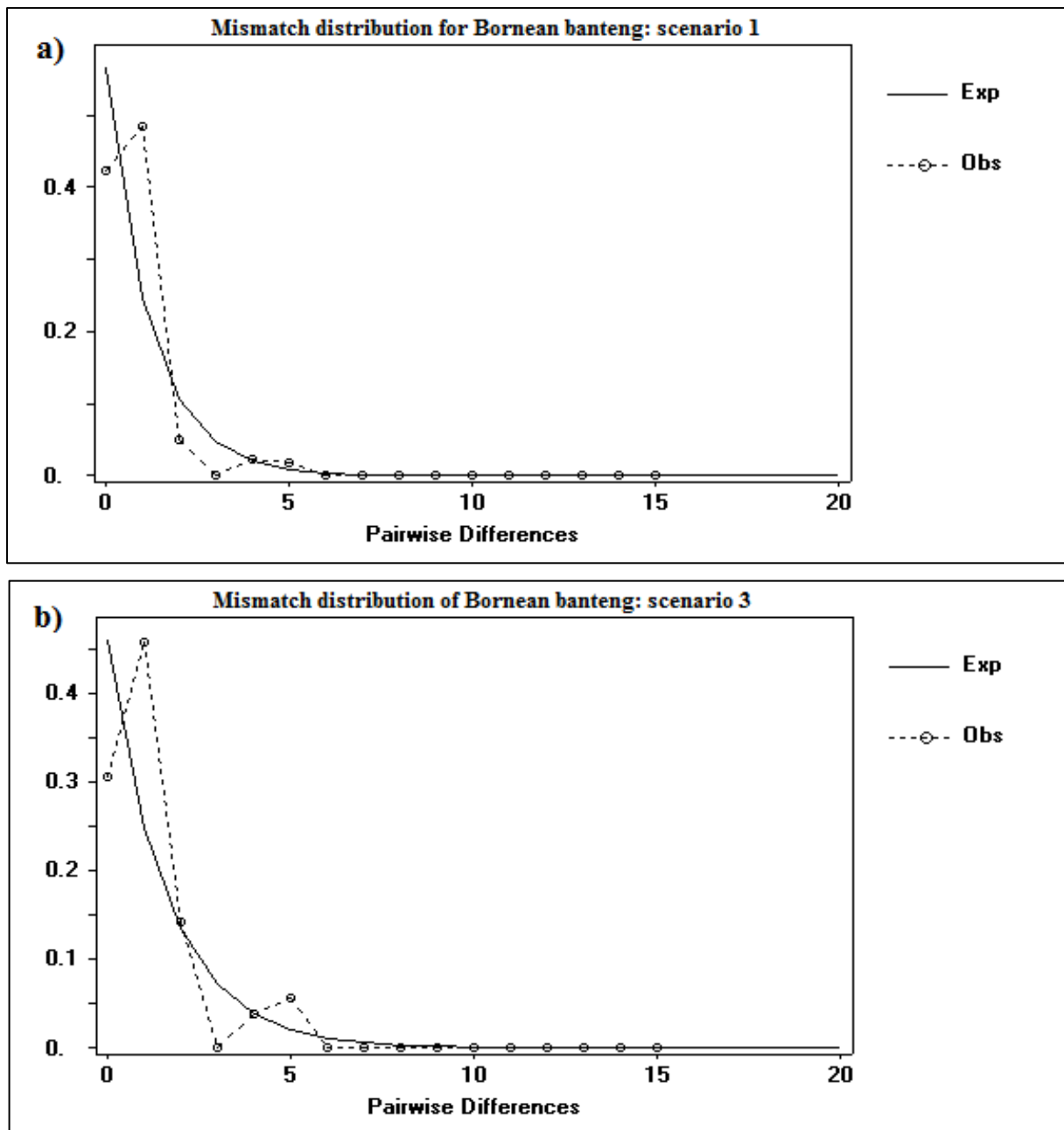

Figure 5.7: The unimodal observed mismatch distributions of the frequency of pairwise differences for two scenarios (scenario 1 and scenario 3) of the Bornean banteng: population (Obs) compared to a simulated population that had experienced expansion (Exp) using a) a significant deviation from an expansion model using all samples from all forests ($p < 0.05$), and b) conformity to an expansion model using samples sorted to herd and forest with replicates of each sex removed (SSD: 0.02, HRI: 0.147 non-significant). Note: there is variation in the y-axis scale between graphs.

The test of sudden population expansion using Fu's F and all samples (scenario 1; $n=49$) was negative but not significant (F_S : -1.881, non-significant: Table 5.3). Using the reduced bias data set with duplicate sequences (scenario 3; $n=21$) also resulted in a not significant negative F_S indicating no evidence of a sudden population expansion (F_S : -1.558, non-significant: Table 5.3).

5.5 Discussion

5.5.1 Amplification success

Amplification success for mtDNA was generally high and 49 samples were successfully sequenced with a continuous mtDNA fragment size that far exceeded many previous studies of *Bos javanicus* (Bradshaw et al., 2006; Matsubayashi et al., 2014; Nijman et al., 2003; Rosli et al., 2011). Amplification of sexing markers was high (87%) with 75 samples successfully sexed. To my knowledge, this was the first time sexing markers have been applied to the Bornean banteng.

Non-invasive sampling may have incurred multiple sampling of the same individual and biased statistics of genetic diversity based on frequencies, however we attempted to account for this by using three different scenarios/data sets, which included all individuals according to forest (scenario 1), all individuals according to herd and forest (scenario 2), and potential duplicate sequences of individuals based on sexing, mtDNA haplotype identity, and herd and forest of origin (scenario 3). This approach allowed us to maximise the potential of the data set by including all sequences, and assess the magnitude of difference between genetic diversity estimates produced using all sequences and using a restricted number of sequences.

Information on banteng nuclear genetic diversity using microsatellite markers would be a useful addition to this study because it would help determine the identity of each sequence and qualify the number of individuals found within each forest, which could then be used to obtain more robust estimates of genetic diversity. My amplification of microsatellite markers using faecal DNA demonstrates the potential for estimating nuclear genetic diversity, and the development of three multiplex panels, which will undoubtedly help to decrease the cost associated with fragment analysis. I found low-amplification success of microsatellite markers during the optimisation process like Pedrono et al., (2009), even in samples that were considered better quality (due to their freshness). This greatly hindered the development of

multiplex panels, wasted a large quantity of valuable DNA, and obscured the allelic range of each marker and the scoring of alleles. Estimates of genotyping errors, such as false alleles and allelic dropout, from replicated samples are required to ensure precision of future analysis.

5.5.2 Phylogeny

The origins of the Bornean banteng were contentious prior to 2014; no studies had acquired DNA allowing investigation of their ancestral lineage. Their endemic status was questioned and confusion reigned over the true subspecies present within Borneo (Melletti & Burton 2014), which increased the case for a merging of subspecies (Timmins et al., 2008). Evidence of ancient records of banteng in Borneo do occur in the form of prehistoric cave paintings and fragments of bones in Kalimantan (Indonesia Borneo), which date circa 10 kya (Bird et al., 2005; Chazine, 2005; Medway, 1964). This evidence suggests that the Bornean banteng is not an introduced species of domestic cattle and is indeed a truly wild bovid, which was further confirmed by the first study of their lineage (Matsubayashi et al., 2014).

My study identified gaur as a sister clade of Bornean banteng that is consistent with the findings of Matsubayashi (2014). Coalescence between Bornean banteng and the gaur occurred between 217 to 634 kya, and the arrival of banteng into Borneo probably occurred between 55-355 kya, when the population expanded producing at least six different haplotypes. I found clear portioning of the three banteng subspecies into different sister clades that suggests they should be managed as separate subspecies. Despite my use of only one calibration point for the Bayesian phylogeny, my phylogeny is consistent with the findings of other studies: my divergence time between banteng, gaur, and kouprey (1.48 to 2.74 mya) is broadly consistent with that of Hassanin and Ropiquet (2004) which suggested they shared a common ancestor at 2.6 ± 0.5 mya. Furthermore, my divergence time between banteng and *B. taurus* (2.51 to 4.43 mya) corresponds with the findings of (MacEachern et al., 2009) who estimated this to be 2.6 mya when using a relaxed molecular clock. The presence of land bridges and a savanna corridor across the Sunda shelf during low sea levels in the last glacial maximum, which was subsequently covered by forest habitat (Al et al., 2004; Bird et al., 2005; Yokoyama et al., 2000), may have provided favourable conditions for banteng migration from mainland Malaya to the Malaya archipelago, and colonisation of Borneo and Java. The island of Borneo has been separated from the Malay peninsula by water for at least 10,000 years and, like the Sumatran rhinoceros, the banteng appears to have

been isolated in Borneo for a period much longer than this (Morales et al., 1997). The divergence of Bornean banteng occurred at a similar time to the split in lineages of the Sunda clouded leopard (Wilting et al., 2011) that has the same number of haplotypes (six) as Bornean banteng (Wilting et al., 2007). The divergence of the Bornean banteng also straddles the divergence times of primates, the Bornean orang-utan (72-322 kya) (Arora et al., 2010) and silvered langur (*Trachypithecus villosus*) (500 kya) (Roos et al., 2008). Ecological constraints such as habitat type and topographical barriers such as rivers would have influenced animal dispersal across the massive contiguous Sunda shelf which may have connected Sumatra and Borneo with mainland southeast Asia during low sea levels (Voris 2000; Cannon et al., 2009). Palynological evidence suggests this shelf was probably populated by open woodland or tropical forest (Bird et al., 2005; Voris 2000; Cannon et al., 2009). The availability of such habitat may have been favourable for banteng dispersal. Furthermore, banteng were probably not hindered by river systems that intersected the exposed land bridges and probably prevented orang-utan migration to/from Borneo (Bird et al., 2005; Arora et al., 2010). With this in mind, it is perhaps not a surprise that the banteng's arrival to Borneo may have pre-dated the orang-utan. However, the overlap in divergence times between the two species may not be significantly different. The evidence gathered by this study, whilst tentative, would appear to support the theory of faunal dispersal into Borneo from the west, proposed by Wallace (1876).

The estimate of the clustering of Javan banteng within *Bos* had a strong probability (100%) even though it was based only on one sample (accession number AY689188), that was obtained from a captive individual (*B. j. javanicus*) in CERZA Zoo in France. The divergence time of the Javan banteng (1.48 -2.74 mya) was earlier than the Bornean banteng, and this finding is consistent, albeit slightly earlier, than the oldest fossil records of early banteng (*Bibos palaesondaicus*) recorded in East Java (0.7-0.9 mya) (Melletti & Burton 2014). This time period corresponds with the inter-species divergence of the Javan rhinoceros (*Rhinoceros sondaicus*) from Ujung Kulon (Java, Indonesia) and Cat Tien (Vietnam), which shared a common ancestor between 2 mya to 300 kya (Fernando et al., 2006). It is likely that additional information on the Javan banteng and also the Burma banteng will become available on GenBank in the near future; recent unpublished research by Mahidol University in Thailand has identified eight haplotypes in the Burma banteng population in Thailand with six of these present within one reserve (Huai Kha Wildlife Sanctuary) (Klinsawat, n.d). Approximately seven individuals from the Lam Pao Dam (Kalasin province) in Thailand

have been identified as of Javan origin suggesting the release of non-native banteng (Klinsawat, n.d) however this finding is based on mtDNA only.

5.5.3 Inferring demographic history

A unimodal mismatch distribution was observed. Thus, the hypothesis that the current population originated from one migrant population of banteng that arrived in Borneo circa 55-355 kya is supported by this analysis. Following this event, a demographic expansion of the population is inferred to have occurred. This is supported by the recognition of a star-like haplotype network, whereby low frequency haplotypes are connected by one substitution to the common haplotype, which could be the result of a population expansion (e.g. Seabra et al., 2014; Wangensteen et al., 2012). Further evidence of a population expansion was elucidated by Tajima's neutrality tests, which significantly deviated from a simulated population with a stable demographic history in both scenarios including the restricted data set. I did not find strong evidence in support of a sudden population expansion using Fu's F_s statistic and this may have been due to an absence of low-frequency haplotypes originating from the second common haplotype (H_3). However, the majority of the other evidence provided by statistical tests of demographic history implied a migration of banteng and a posterior population expansion. My finding of six haplotypes was the same as that of the Sunda clouded leopard (*N. diardi*) for the whole of Borneo (Wilting et al., 2007; Wilting et al., 2011). Based on the similar divergence times, 217-634 kya for the Bornean banteng and 331 kya for the Bornean clouded leopard (Wilting et al., 2011), migration of banteng into Borneo and their population expansion may have occurred at the same time as the clouded leopard.

During the colonisation event on Borneo, it appears dispersal of banteng was not constrained by topographic barriers such as major rivers and a mountain range intersecting the interior forests of Sabah. This was substantiated in the field; in late 2013 banteng were documented in steep terrain at high elevations (>1,000m above sea level) in the west of Sabah (P. Gardner, unpublished, but no faecal samples were available for molecular analysis), and also substantiated using molecular techniques; the distribution of haplotypes is fairly homogenous across the east and central Sabah landscape except for a few low-frequency haplotypes (in two forest reserves: Malua and Tabin), and the lack of evidence of a population structure using the Mantel test and spatial autocorrelation analysis. For some large mammals (i.e. Asian elephant *Elephas maximus*), dispersal across a forested landscape

intersected by large rivers is possible (Fernando et al., 2003). The haplotype diversity of the banteng and the Sunda clouded leopard exhibit the same homogenous pattern over large distances (Fernando et al., 2003; Goossens et al., n.d.; Wilting et al., 2011). This is not the case for all long-distance dispersers however, as demonstrated in the orang-utan, whereby a large river resulted in genetic differentiation and extremely low immigration rates between populations either side of a river (Goossens et al., 2005; Jalil et al., 2008).

5.5.4 Genetic diversity

From the relatively small sample size obtained of this study ($n=49$), I observed a higher number of haplotypes (six haplotypes, H_d : 0.58) than that found by Matsubayashi et al., (2014) using the same number of study sites (4). The presence of four low-frequency haplotypes not previously detected dramatically increased the known diversity of the Bornean banteng. Comparisons with the other banteng subspecies indicated the number of haplotypes in the present study is also higher than that observed in Javan banteng in Java (two haplotypes, Klinsawat, n.d.). The diversity of the Burmese banteng however is comparable, with six haplotypes present in Huai Kha Wildlife Sanctuary (Thailand), based on an mtDNA fragment size of 1,079bp including cytochrome-*b* gene and control region/d-loop (Klinsawat n.d.). It is important to reiterate that this finding is based only on mtDNA, and that to have a more complete understanding of the genetic diversity of banteng present within both Borneo and Thailand, it is essential to analyse nuclear DNA.

Comparison of Bornean banteng genetic diversity with other large Old World wildlife indicate the coexisting long-tailed macaque (*Macaca fascicularis*) exhibited high haplotype diversity with 21 unique haplotypes, with half found only on the southern side of the Kinabatangan river in Sabah (Jalil et al., 2008). Within the same location, the Kinabatangan Wildlife Sanctuary, the orang-utan exhibited a similar pattern of genetic diversity, with considerable genetic differentiation within Borneo (H_d : 0.83) (Nater et al., 2011) between opposites of a major tributary in Sabah (Goossens et al., 2005; Jalil, 2006). Conversely, the proboscis monkey (*Nasalis larvatus*) exhibits relative homogeneity across the landscape, with haplotypes shared between populations in the east and the west of Sabah that may be attributed to their ability to swim across rivers (Munshi-South & Bernard 2011). Comparisons with the rare and secretive dwarf buffalo anoa (Mountain anoa: *Bubalus quarlesi* and Lowland anoa: *B. depressicornis*) endemic to the islands of Sulawesi and Buton (Indonesia) identified as many as 16 nucleotide sites in a short fragment of cytochrome-*b*

(285bp) separating the anoa from *Bos* species (Schreiber et al., 1999). Only four haplotypes were identified in the two anoa species but with a deep divergence time of 1.25 mya which may imply that they were unlikely to have evolved in a continuous population (Schreiber et al., 1999; Burton et al., 2005). The anoa exhibits a far higher level of nucleotide substitution than interspecific differences (0.4% nucleotide substitutions) found in the banteng (Burton et al., 2005). Conversely, similarities to the Bornean banteng are evident in the Asian elephant, which probably experienced a population expansion following colonisation of Sri Lanka (H_d : 0.87, π : 0.017) (Fernando et al., 2000). Within Borneo, the Asian elephant lacks mitochondrial diversity, with only a single haplotype widely distributed throughout the lowlands of east and central Sabah (Fernando et al., 2003; Goossens et al., n.d.). Whilst the banteng exhibits higher genetic diversity than the Asian elephant, these elephants exhibit low intraspecific genetic diversity. This may be due, in part, to anthropogenic colonisation supposedly in the 1800s involving a few founder individuals, a relatively recent colonisation time and short period in which mutations could be accumulated, and/or a slow mutation rate. It may also be due to other demographic events, such as population bottlenecks, which could have removed low-frequency haplotypes. Whilst there is only a little evidence to support the prehistoric recognition and hunting of banteng in Borneo, overhunting by hunter-gathers during the late Pleistocene may have caused a population bottleneck (Nater et al., 2014; in the orang-utan). This study included samples from almost the whole range of the banteng in Sabah except the west, and although sampling was not exhaustive, a long fragment of the mtDNA comprising the cytochrome-*b* gene and control region can improve estimations of low diversity at this genetic marker. Identification of diversity by using a long concatenated sequence and selection of the hypervariable d-loop gene may have a) increased the probability of detecting nucleotide substitutions, and also b) rejected the theory by Matsubayashi et al., (2014) that the Bornean banteng mtDNA diversity is misleading for phylogenetic analyses, as my comparisons with gaur sequences available from GenBank indicated these were almost identical (99% match).

5.5.5 Conservation implications

This research identified two high frequency haplotypes that were predominant in all forests, yet four low-frequency haplotypes were only identified in Malua (2) and Tabin (2), within areas that have recently (past four decades) experienced widespread disturbance from timber harvesting and unwarranted hunting for bush meat. There is little regard for the 'totally protected' status of the banteng under the 1997 Sabah Wildlife Conservation Enactment

(Sabah Wildlife Department 1997) and the no-hunting policies within reserves. Various methods of hunting were observed, however hunting using firearms was the predominate method within the localities containing the rarer/low-frequency haplotypes. These haplotypes are susceptible to eradication and their loss would result in a genetically depauperate species. As with the Burmese banteng in Vietnam, I recommend enforcement of the legislation on wildlife hunting and trade to stem poaching of banteng (Pedrono et al., 2009). Inclusion of banteng into CITES Appendix I, previously proposed by Hedges (1996) is essential to reinforce the message that trade in banteng products is not permissible. In terms of conservation management, the central forest patch comprises Malua, Ulu-Segama and Maliau, whereas Tabin is a more isolated forest patch in eastern Sabah. mtDNA estimated genetic diversity levels indicates banteng within the central forest and Tabin can be managed as separate units for the time being, in order to maintain diversity. However, haplotype loss would amplify the need for connectivity between these two areas to facilitate gene flow.

5.5.6 Further work

The dating of the phylogeny should be considered tentative as calibration was based on a single time constraint. Increased accuracy could be explored by further calibration of multiple time constraints from the literature and also using mutation rates specific to *Bos* species to obtain confidence intervals of divergence times.

Creation of habitat corridors and ecological restoration are very important components of long-term sustainable conservation management (Bruford et al., 2010). As with the Bornean orang-utan and elephant, information on genetic diversity from the nuclear genome would allow us to gauge if habitat fragmentation is detrimental and if gene flow must be reinforced by re-establishing habitat connectivity (Bruford et al., 2010; Goossens et al., 2005; Goossens et al., n.d; for the Bornean elephant).

The resolution of genetic diversity of banteng herds requires the application of nuclear microsatellite DNA markers to confirm the number of individuals and the frequencies of sequences for each individual, to estimate the current effective population size, and to provide an index of genetic diversity of herds, the current levels of inbreeding and the population structure. Microsatellites and PCR multiplex protocols have been developed for *Bos* by the FAO (2011) and have been applied to domesticated banteng (Handiwirawan et al., 2003; Nijman et al., 2003) and feral banteng in Australia (Bradshaw et al., 2007). They have also been applied to faecal DNA from the Burmese banteng in Vietnam (Pedrono et al., 2009)

however they were unsuccessful due to low amplification. Microsatellite markers have not been used to examine the genetic diversity of the Bornean banteng, the Burmese banteng in Thailand (W. Klinsawat, pers. comm.) or, to the best of my knowledge, to the Javan banteng. During this study I attempted to amplify 13 microsatellite markers in three multiplexes however extremely poor amplification success obscured the optimisation process and prevented the scoring of alleles.

Identifying the presence of remnant banteng populations in Sabah and confirming their genetic diversity would help identify the relative haplotype diversity of the two management units. New haplotypes would be advantageous for management, and undescribed populations may be key to ensuring long-term conservation of this species. Additional sampling for faecal DNA in other forests commenced in January 2013 under a new study (*Conservation and management of the endangered wild cattle Bornean Banteng (B. j. lowi) in Sabah*) by Penny C. Gardner and Benoît Goossens, which aims to confirm remnant banteng populations across Sabah. These samples may increase the number of haplotypes and elucidate new management units, particularly in the west of Sabah where steep ridges and large fast-flowing rivers may have prevented past and present gene flow.

5.7 References

- Al, E.T., Gorog, A.J., Sinaga, M.H. & Engstrom, M.D., 2004. Vicariance or dispersal? Historical biogeography of three Sunda shelf murine rodents (*Maxomys surifer*, *Leopoldamys sabanus* and *Maxomys whiteheadi*). *Biological Journal of the Linnean Society*, 81(91), pp.91–109.
- Ancrenaz, M., Sollmann, R., Meijaard, E., Hearn, A.J., Ross, J., Samejima, H., Loken, B., Cheyne, S.M., Stark, D.J., Gardner, P.C., Goossens, B., Mohamed, A., Bohm, T., Matsuda, I., Nakabayasi, M., Lee, S.K., Bernard, H., Brodie, J., Wich, S. et al., 2014. Coming down from the trees: Is terrestrial activity in Bornean orangutans natural or disturbance driven? *Nature: Scientific Reports*, 4, e4024.
- Arandjelovic, M., Head, J., Köhl, H., Boesch, C., Robbins, M.M., Maisels, F. & Vigilant, L., 2010. Effective non-invasive genetic monitoring of multiple wild western gorilla groups. *Biological Conservation*, 143(7), pp.1780–1791.
- Arora, N., Nater, A., van Schaik, C.P., Willems, E.P., van Noordwijk, M. a, Goossens, B., Morf, N., Bastian, M., Knott, C., Morrogh-Bernard, H., Kuze, N., Kanamori, T., Pamungkas, J., Perwitasari-Farajallah, D., Verschoor, E., Warren, K. & Krützen, M., 2010. Effects of Pleistocene glaciations and rivers on the population structure of Bornean orangutans (*Pongo pygmaeus*). *Proceedings of the National Academy of Sciences of the United States of America*, 107(50), pp.21376–81.
- Avise, J.C., 1994. Mitochondrial DNA polymorphism and a connection between genetics and demography of relevance to conservation. *Conservation Biology*, 9(3), pp.686–690.
- Bird, M.I., Taylor, D. & Hunt, C., 2005. Palaeoenvironments of insular Southeast Asia during the Last Glacial Period: a savanna corridor in Sundaland? *Quaternary Science Reviews*, 24(20-21), pp.2228–2242.
- Bolliger, J., Lander, T. & Balkenhol, N., 2014. Landscape genetics since 2003: status, challenges and future directions. *Landscape Ecology*, 29(3), pp.361–366.
- Bradshaw, C.J., Isagi, Y., Kaneko, S., Bowman, D.M.J.S. & Brook, B.W., 2006. Conservation value of non-native banteng in northern Australia. *Conservation Biology*, 20(4), pp.1306–1311.
- Bradshaw, C.J., Isagi, Y., Kaneko, S., Brook, B.W., Bowman, D.M.J.S. & Frankham, R., 2007. Low genetic diversity in the bottlenecked population of endangered non-native banteng in northern Australia. *Molecular Ecology*, 16(14), pp.2998–3008.
- Brodie, J.F., Giordano, A.J. & Ambu, L., 2015. Differential responses of large mammals to logging and edge effects. *Mammalian Biology*, 80(1), pp.7–13.
- Bruford, M., Ancrenaz, M., Chikhi, L., Lackmann-Ancrenaz, I., Andau, M., Ambu, L. & Goossens, B., 2010. Projecting genetic diversity and population viability for the fragmented orang-utan population in the Kinabatangan floodplain, Sabah, Malaysia. *Endangered Species Research*, 12(3), pp.249–261.

- Burton, J.A., Hedges, S. & Mustari, A.H., 2005. The taxonomic status, distribution and conservation of the lowland anoa *Bubalus depressicornis* and mountain anoa *Bubalus quarlesi*. *Mammal Review*, 35(1), pp.25–50.
- Cannon, C.H., Morley, R.J. & Bush, A.B.G., 2009. The current refugial rainforests of Sundaland are unrepresentative of their biogeographic past and highly vulnerable to disturbance. *Proceedings of the National Academy of Sciences of the United States of America*, 106(27), pp.11188–93.
- Chazine, J.M., 2005. Rock art, burials, and habitations: Caves in East Kalimantan. *University of Hawai'i Press*, 44(1), pp.219–230.
- Development Team, 2012. Quantum GIS Geographical Information System. Available at: <http://www.qgis.org/en/site/>.
- Edwards, D.L., Garrick, R.C., Tapia, W. & Caccone, a., 2014. Cryptic structure and niche divergence within threatened Galápagos giant tortoises from southern Isabela Island. *Conservation Genetics*, 15(6), pp.1357–1369.
- ESRI, 2014. ArcGIS. Available at: <http://www.esri.com/software/arcgis>.
- Excoffier, L. & Lischer, H., 2011. Arlequin Ver 3.5: An integrated software package for population genetics data analysis, p.174.
- Fernando, P., Pfrender, M.E., Encalada, S.E. & Lande, R., 2000. Mitochondrial DNA variation, phylogeography and population structure of the Asian elephant. *Heredity*, 84(November 1999), pp.362–372.
- Fernando, P., Polet, G., Foad, N., Ng, L.S., Pastorini, J. & Melnick, D.J., 2006. Genetic diversity, phylogeny and conservation of the Javan rhinoceros (*Rhinoceros sondaicus*). *Conservation Genetics*, 7(3), pp.439–448.
- Fernando, P., Vidya, T.N.C., Payne, J., Stuewe, M., Davison, G., Alfred, R.J., Andau, P., Bosi, E., Kilbourn, A. & Melnick, D.J., 2003. DNA analysis indicates that Asian elephants are native to Borneo and are therefore a high priority for conservation. *PLoS Biology*, 1(1), e6.
- Ferreira da Silva, M.J., 2012. *Hunting pressure and the population genetic patterns and sex-mediated dispersal in the Guinea Baboon in*. PhD thesis, Cardiff University.
- Ferreira da Silva, M.J., Godinho, R., Casanova, C., Minhós, T., Sá, R. & Bruford, M.W., 2014. Assessing the impact of hunting pressure on population structure of Guinea baboons (*Papio papio*) in Guinea-Bissau. *Conservation Genetics*, 15(6), pp.1339–1355.
- Food and Agriculture Organization of the United Nations (FAO), 2011. *Molecular genetic characterization of animal genetic resources*, Rome.
- Frankham, R., Ballou, J. & Briscoe, D., 2010. *Introduction to conservation genetics*, Cambridge: Cambridge University Press.

- Gaveau, D.L., Sloan, S., Molidena, E., Yaen, H., Sheil, D., Abram, N.K., Ancrenaz, M., Nasi, R., Quinones, M., Wielaard, N. & Meijaard, E., 2014. Four Decades of Forest Persistence, Clearance and Logging on Borneo. *PLoS One*, 9(7), e101654.
- Goossens, B., Chikhi, L., Ancrenaz, M., Lackman-Ancrenaz, I., Andau, P. & Bruford, M.W., 2006. Genetic signature of anthropogenic population collapse in orang-utans. *PLoS Biology*, 4(2), e25.
- Goossens, B., Chikhi, L., Jalil, M.F., Ancrenaz, M., Lackman-Ancrenaz, I., Mohamed, M., Andau, P. & Bruford, M.W., 2005. Patterns of genetic diversity and migration in increasingly fragmented and declining orang-utan (*Pongo pygmaeus*) populations from Sabah, Malaysia. *Molecular Ecology*, 14(2), pp.441–56.
- Goossens, B., Salgado-Lynn, M., Rovie-Ryan, J.J., Ahmad, A.H., Payne, J., Zainuddin, Z.Z., Nathan, S.K.S.S. & Ambu, L.N., 2013. Genetics and the last stand of the Sumatran rhinoceros *Dicerorhinus sumatrensis*. *Oryx*, 47(03), pp.340–344.
- Goossens, B., Sharma, R., Rodrigues, C.K., Othman, N., Sakong, R., Ancrenaz, M., Ambu, L.N., Jue, N.K., O'Neill, R.J., Bruford, M.W. & Chikhi, L., n.d. Habitat fragmentation and genetic diversity in natural populations of the Bornean elephant: implications for conservation.
- Hall, T.A., 1999. BioEdit: a user-friendly biological sequence alignment editor and analysis program for Windows 95/98/NT. *Nucleic Acids Symposium Series*, 41, pp.95–98.
- Handiwirawan, E., Noor, R.R. & Schüler, L., 2003. The Use of HEL9 and INRA035 microsatellites as specific markers for Bali cattle. *Arciv Tierzucht*, 46(6), pp.503–512.
- Hassanin, A. & Ropiquet, A., 2004. Molecular phylogeny of the tribe Bovini (Bovidae, Bovinae) and the taxonomic status of the Kouprey, *Bos sauveli* (Urbain 1937). *Molecular Phylogenetics and Evolution*, 33(3), pp.896–907.
- Hassanin, A. & Ropiquet, A., 2007. Resolving a zoological mystery: the kouprey is a real species. *Proceedings of the Royal Society B: Biological sciences*, 274(1627), pp.2849–55.
- Hedges, S., 1996. *Proposal for inclusion of banteng (Bos javanicus) in CITES Appendix I. IUCN/SSC Asian Wild Cattle Specialist Group, the IUCN Wildlife trade Programme, and the Thai Government.*
- Hickerson, M.J., Carstens, B.C., Cavender-Bares, J., Crandall, K. a, Graham, C.H., Johnson, J.B., Rissler, L., Victoriano, P.F. & Yoder, a D., 2010. Phylogeography's past, present, and future: 10 years after Avise, 2000. *Molecular Phylogenetics and Evolution*, 54(1), pp.291–301.
- Holder, M. & Lewis, P.O., 2003. Phylogeny estimation: traditional and Bayesian approaches. *Nature reviews. Genetics*, 4(4), pp.275–84.
- Hu, Y., Zhan, X., Qi, D. & Wei, F., 2010. Spatial genetic structure and dispersal of giant pandas on a mountain-range scale. *Conservation Genetics*, 11(6), pp.2145–2155.

- Huelsenbeck, J., Larget, B., van der Mark, P., Ronquist, F., Simon, D. & Teslenko, M., 2014. MrBayes: Bayesian inference of phylogeny. Available at: <http://mrbayes.sourceforge.net/download.php>.
- Ihara, N., Takasuga, A., Mizoshita, K., Takeda, H., Sugimoto, M., Mizoguchi, Y., Hirano, T., Itoh, T., Watanabe, T., Reed, K.M., Snelling, W.M., Kappes, S.M., Beattie, C.W., Bennett, G.L. & Sugimoto, Y., 2004. A comprehensive genetic map of the cattle genome based on 3802 microsatellites. *Genome Research*, 14(10A), pp.1987–98.
- Ismail, S. a., Ghazoul, J., Ravikanth, G., Kushalappa, C.G., Uma Shaanker, R. & Kettle, C.J., 2014. Fragmentation Genetics of *Vateria indica*: implications for management of forest genetic resources of an endemic dipterocarp. *Conservation Genetics*, 15(3), pp.533–545.
- Jalil, F.B., 2006. *Comparative phylogeography of three primate species in the Lower Kinabatangan Wildlife Sanctuary, Sabah, Malaysia*. PhD thesis, Cardiff University.
- Jalil, M.F., Cable, J., Sinyor, J., Lackman-Ancrenaz, I., Ancrenaz, M., Bruford, M.W. & Goossens, B., 2008. Riverine effects on mitochondrial structure of Bornean orangutans (*Pongo pygmaeus*) at two spatial scales. *Molecular Ecology*, 17(12), pp.2898–909.
- Jullien, N., 2013. AmplifX. Available at: <http://crn2m.univ-mrs.fr/pub/amplifx>.
- Klinsawat, W., n.d. *The genetic diversity of Banteng populations across Thailand and its evolutionary relationship with the Javan banteng based on mtDNA*.
- MacEachern, S., McEwan, J. & Goddard, M., 2009. Phylogenetic reconstruction and the identification of ancient polymorphism in the Bovini tribe (Bovidae, Bovinae). *BMC Genomics*, 10, e177.
- Matsubayashi, H., Hanzawa, K., Kono, T., Ishige, T., Gakuhari, T., Lagan, P., Sunjoto, I., Sukor, J.R.A., Sinun, W. & Ahmad, A.H., 2014. First molecular data on Bornean banteng *Bos javanicus lowi* (Cetartiodactyla, Bovidae) from Sabah, Malaysian Borneo. *Mammalia*, 78, pp.1–9.
- Medway, L., 1964. Post-Pleistocene changes in the mammalian fauna of Borneo. *Studies in Speleology*, 1, pp.33–37.
- Meirelles, F., Rosa, A.J., Lôbo, R. & Garcia, J., 1999. Is the American zebu really *Bos indicus*? *Genetics and Molecular Biology*, 22(4), pp.543–546.
- Melletti, M. & Burton, J. eds., 2014. *Ecology, evolution and behaviour of wild Cattle: Implications For Conservation*, Cambridge: Cambridge University Press.
- Miller, M.P., 2005. Alleles in space (AIS): computer software for the joint analysis of interindividual spatial and genetic information. *The Journal of Heredity*, 96(6), pp.722–4.
- Morales, J.C., Andau, P.M., Supriatna, J., Zainuddin, Z.Z. & Melnick, D.J., 1997. Mitochondrial DNA variability and conservation genetics of the Sumatran rhinoceros. *Conservation Biology*, 11(2), pp.539–543.

- Munshi-South, J. & Bernard, H., 2011. Genetic diversity and distinctiveness of the proboscis monkeys (*Nasalis larvatus*) of the Klias Peninsula, Sabah, Malaysia. *The Journal of heredity*, 102(3), pp.342–6.
- Nater, A., Greminger, M.P., Arora, N., van Schaik, C.P., Goossens, B., Singleton, I., Verschoor, E.J., Warren, K.S. & Krützen, M., 2014. Reconstructing the demographic history of orang-utans using approximate bayesian computation. *Molecular Ecology*, 24(2), pp.310-327.
- Nater, A., Nietlisbach, P., Arora, N., van Schaik, C.P., van Noordwijk, M. a, Willems, E.P., Singleton, I., Wich, S. a, Goossens, B., Warren, K.S., Verschoor, E.J., Perwitasari-Farajallah, D., Pamungkas, J. & Krützen, M., 2011. Sex-biased dispersal and volcanic activities shaped phylogeographic patterns of extant orangutans (genus: Pongo). *Molecular Biology and Evolution*, 28(8), pp.2275–88.
- Nietlisbach, P., Arora, N., Nater, A., Goossens, B., Van Schaik, C.P. & Krützen, M., 2012. Heavily male-biased long-distance dispersal of orang-utans (genus: Pongo), as revealed by Y-chromosomal and mitochondrial genetic markers. *Molecular Ecology*, 21(13), pp.3173–86.
- Nijman, I.J., Otsen, M., Verkaar, E.L.C., de Ruijter, C., Hanekamp, E., Ochieng, J.W., Shamshad, S., Rege, J.E.O., Hanotte, O., Barwegen, M.W., Sulawati, T. & Lenstra, J. 2003. Hybridization of banteng (*Bos javanicus*) and zebu (*Bos indicus*) revealed by mitochondrial DNA, satellite DNA, AFLP and microsatellites. *Heredity*, 90(1), pp.10–6.
- Nsubuga, M., Robbins, M.M., Roeder, D., Morin, P., Boesch, C. & Vigilant, L., 2004. Factors affecting the amount of genomic DNA extracted from ape faeces and the identification of an improved sample storage method. *Molecular Ecology*, 13(7), pp.2089–94.
- Pedrono, M., Tuan, H.M., Chouteau, P. & Vallejo, F., 2009. Status and distribution of the endangered banteng *Bos javanicus birmanicus* in Vietnam: a conservation tragedy. *Oryx*, 43(04), p.618.
- Polzin, T. & Daneshman, S. V, 2004. NETWORK. Available at: <http://www.fluxus-engineering.com/sharenet.htm>.
- Rivière-Dobigny, T., Doan, L.P., Quang, N. Le, Maillard, J.-C. & Michaux, J., 2009. Species identification, molecular sexing and genotyping using non-invasive approaches in two wild bovids species: *Bos gaurus* and *Bos javanicus*. *Zoo Biology*, 28(2), pp.127–36.
- Rodrigues, T.M., 2012. *Socio-genetics and population structure of two African colobus monkeys in Cantanhez National Park , Guinea Bissau*. PhD thesis, Cardiff University.
- Ronquist, F., Huelsenbeck, J. & Teslenko, M., 2011. Draft MrBayes version 3. 2 Manual: Tutorials and Model Summaries. Available at: <http://mrbayes.sourceforge.net/manual.php>, p.105.

- Ronquist, F., Klopfstein, S., Vilhelmsen, L., Schulmeister, S., Murray, D.L. & Rasnitsyn, A.P., 2012. A total-evidence approach to dating with fossils, applied to the early radiation of the hymenoptera. *Systematic biology*, 61(6), pp.973–99.
- Roos, C., Nadler, T. & Walter, L., 2008. Mitochondrial phylogeny, taxonomy and biogeography of the silvered langur species group (*Trachypithecus cristatus*). *Molecular Phylogenetics and Evolution*, 47(2), pp.629–36.
- Rosli, M.K.A., Zakaria, S.S., Syed-Shabthar, S.M.F., Zainal, Z.Z., Shukor, M.N., Mahani, M.C., Abas-Mazni, O. & Md-Zain, B.M., 2011. Phylogenetic relationships of Malayan gaur with other species of the genus *Bos* based on cytochrome b gene DNA sequences. *Genetics and Molecular Research*, 10(1), pp.482–93.
- Rozas, J., Librado, P., Sanchez-DelBarrio, C., Messeguer, X. & Rozas, R., 2010. DnaSP: DNA sequence polymorphism. Available at: <http://www.ub.es/dnasp>.
- Sa, R.M.M., 2012. *Phylogeography, conservation genetics and parasitology of chimpanzees (Pan troglodytes verus) in Guinea-Bissau, West Africa*. PhD thesis, Universidade Nova de Lisboa.
- Sabah Wildlife Department, 1997. *Wildlife conservation enactment*, Kota Kinabalu.
- Saitou, N. & Nei, M., 1987. The neighbor-joining method: A new method for reconstructing phylogenetic trees. *Molecular Biology and Evolution*, 4, pp.406–425.
- Schreiber, A., Seibold, I., No, G. & Wink, M., 1999. Cytochrome *b* gene haplotypes characterize chromosomal lineages of anoa, the Sulawesi dwarf buffalo (Bovidae: *Bubalus* sp.). *The Journal of Heredity*, 90(1), pp.165–176.
- Seabra, S.G., Brás, P.G., Martins, J., Martins, R., Wyatt, N., Shirazi, J., Rebelo, M.T., Franco, J.C., Mateus, C., Figueiredo, E. & Paulo, O.S., 2015. Phylogeographical patterns in *Coenosia attenuata* (Diptera: Muscidae): a widespread predator of insect species associated with greenhouse crops. *Biological Journal of the Linnean Society*, 114(2), pp.308–326.
- Shafer, A.B., Wolf, J.B.W., Alves, P.C., Bergström, L., Bruford, M.W., Brännström, I., Colling, G., Dalén, L., De Meester, L., Ekblom, R., Fawcett, K.D., Fior, S., Hajibabaei, M., Hill, J., Hoesel, R., Höglund, J., Jensen, E.L., Krause, J., Kristensen, T.N. et al., 2015. Genomics and the challenging translation into conservation practice. *Trends in Ecology & Evolution*, 30(2), pp.78–87.
- Slatkin, M. & Richard, R., 1991. Pairwise comparisons of mitochondrial DNA sequences in stable and exponentially growing populations. *Genetics*, 129, pp.555–562.
- Soto-Calderón, I.D., Ntie, S., Mickala, P., Maisels, F., Wickings, E.J. & Anthony, N.M., 2009. Effects of storage type and time on DNA amplification success in tropical ungulate faeces. *Molecular Ecology Resources*, 9(2), pp.471–9.
- Stanton, D., 2014. *Phylogeography, population genetics and conservation of the okapi (Okapia & johnstoni)*. PhD thesis, Cardiff University.

- Syed-Shabthar, S.M., Rosli, M.K., Mohd-Zin, N.A., Romaino, S.M., Fazly-Ann, Z., Mahani, M.C., Abas-Mazni, O., Zainuddin, R., Yaakop, S. & Md-Zain, B., 2013. The molecular phylogenetic signature of Bali cattle revealed by maternal and paternal markers. *Molecular Biology Reports*, 40(8), pp.5165–5176.
- Tamura, K., Battistuzzi, F.U., Billing-Ross, P., Murillo, O., Filipski, A. & Kumar, S., 2012. Estimating divergence times in large molecular phylogenies. *Proceedings of the National Academy of Sciences of the United States of America*, 109(47), pp.19333–8.
- Tamura, K., Stecher, G., Peterson, D., Filipski, A. & Kumar, S., 2013. MEGA6: Molecular evolutionary genetics analysis version 6.0. *Molecular Biology and Evolution*, 30(12), pp.2725–9.
- Timmins, R.J., Duckworth, J.W., Hedges, S., Steinmetz, R. & Pattanavibool, A., 2008. *Bos javanicus*. In: IUCN 2012. IUCN Red List of threatened species. Available at: www.iucnredlist.org/details/biblio/2888/0.
- Voris, H.K., 2000. Maps of Pleistocene sea levels in Southeast Asia: shorelines, river systems and time durations. *Journal of Biogeography*, 27, pp.1153–1167.
- Wallace, A.R., 1876. *The geographical distribution of animals*, New York: Harper and Brothers.
- Wangensteen, O.S., Turon, X., Pérez-Portela, R. & Palacín, C., 2012. Natural or naturalized? Phylogeography suggests that the abundant sea urchin *Arbacia lixula* is a recent colonizer of the Mediterranean. *PloS One*, 7(9), e45067.
- Wilting, A., Buckley-Beason, V. a, Feldhaar, H., Gadau, J., O'brien, S.J. & Linsenmair, K.E., 2007. Clouded leopard phylogeny revisited: support for species recognition and population division between Borneo and Sumatra. *Frontiers in Zoology*, 4(15), pp.1–10.
- Wilting, A., Christiansen, P., Kitchener, A.C., Kemp, Y.J.M., Ambu, L. & Fickel, J., 2011. Geographical variation in and evolutionary history of the Sunda clouded leopard (*Neofelis diardi*) (Mammalia: Carnivora: Felidae) with the description of a new subspecies from Borneo. *Molecular Phylogenetics and Evolution*, 58(2), pp.317–28.
- Yokoyama, Y., Lambeck, K. & Deckker, P. De, 2000. Timing of the Last Glacial Maximum from observed sea-level minima. *Nature*, 406(August), pp.1998–2001.

5.8 Appendices

1. Label 2ml micro-centrifuge tubes and add approximately 2g of faecal material
 2. Add 1.4ml Buffer ASL to each sample and vortex continuously for 1 min
 3. Heat the suspension for 5 mins at 70°C and then leave to soak for a minimum of 48hrs
 4. Vortex sample for 20 mins and then centrifuge at full speed for 3 mins.
 5. Pipet 1.2ml of the supernatant into new 2ml micro-centrifuge tube & discard the pellet
 6. Carefully add 1 InhibitEX tablet to each sample and vortex immediately for 1 min.
 7. Incubate at room temperature for 10 min and then centrifuge sample at full speed for 10 mins.
 8. Pipet all the supernatant into the new 1.5ml micro-centrifuge tube and centrifuge the sample at full speed for 3 mins.
 9. Label new 1.5ml micro-centrifuge tubes and pipet 15µl proteinase K into a new 1.5ml micro-centrifuge tube, then pipet 200µl of supernatant into the proteinase K tube and lastly 200µl AL Buffer,
 10. Vortex for 15 seconds then incubate at 70°C for 30 mins.
 11. Centrifuge briefly to remove condensation from lid and add 200µl of cold ethanol to the lysate.
 12. Vortex for 2mins and then centrifuge for 5 seconds to remove condensation from lid.
 13. Pipet the lysate into a spin column and centrifuge at full speed for 1 min.
 14. Remove spin column and place into new 2ml collection tube, discarding the old tube containing the filtrate.
 15. Add 500µl of Buffer AW1 to the spin column and centrifuge at full speed for 1 min.
 16. Remove spin column and place in new 2ml collection tube.
 17. Add 500µl of Buffer AW2 and centrifuge at full speed for 3 mins.
 18. Place spin column into new 2ml collection tube and centrifuge at full speed for 1 min.
 19. Remove spin column and place in new 1.5ml micro-centrifuge tube
-
20. Pipet 100µl Buffer AE into membrane and incubate at room temperature for 20 mins
 21. Centrifuge at full speed for 1 min and pipet another 100µl Buffer AE into membrane
- Repeat steps 20 and 21 four times for higher volume.*
-
22. Discard spin column and store DNA in -80°C freezer

Appendix 5.1: Modified QIAGEN QIAamp® DNA extraction protocol used for optimum DNA yield from banteng faeces, collected and stored using the two-step (ethanol/silica gel) method. The final stages (20-21) were repeated for double DNA yield as PCR and amplification success of mitochondria cytochrome-*b* gene, tRNA and control region/d-loop required higher quantities of DNA.

Appendix 5.2: GenBank accession numbers and complete (Φ) and partial (\ddagger) sequences of other *Bos* species used in the alignment to design mtDNA primers. Sequences were used to identify regions with high polymorphism and more conserved regions where primers were designed. Four overlapping fragments spanning cytochrome-*b* gene, tRNA and control region/d-loop were amplified to create a long sequence from each *B. j. lowi* faecal sample.

GenBank Accession number	Species	Gene/Region		
		Cytochrome- <i>b</i>	tRNA	Control region/d-loop
EU747735.1	<i>Bos javanicus</i>	Φ	Φ	\ddagger
D34636.1	<i>Bos javanicus</i>	Φ		
D82889.1	<i>Bos javanicus</i>	Φ		
EU878389.1	<i>Bos javanicus</i>	\ddagger		
AY079131.1	<i>Bos javanicus</i>	\ddagger		
EF693809.1	<i>Bos javanicus</i>			\ddagger
AB703049.1	<i>Bos javanicus</i>			\ddagger
GU324988.1	<i>Bos gaurus</i>	Φ	Φ	Φ
DQ459331.1	<i>Bos gaurus</i>	Φ		
AF348593.2	<i>Bos gaurus</i>	\ddagger		
AB077316.1	<i>Bos gaurus</i>	\ddagger		
AF485067.1	<i>Bos gaurus</i>		\ddagger	\ddagger
DQ377061.1	<i>Bos gaurus</i>			\ddagger
HM215246.1	<i>Bos gaurus</i>			\ddagger
EF693812.1	<i>Bos sauveli</i>			\ddagger
EU747736.1	<i>Bos taurus</i>	Φ	Φ	\ddagger
D34635.1	<i>Bos taurus</i>	Φ		
HM596476.1	<i>Bos taurus</i>			\ddagger
AM279287.1	<i>Bos taurus</i>			\ddagger
U50944.1	<i>Bos taurus</i>			\ddagger
U50943.1	<i>Bos taurus</i>			\ddagger
AB003801.1	<i>Bos taurus</i>			\ddagger
EF524185.1	<i>Bos indicus</i>			Φ
AB085921.1	<i>Bos indicus</i>			Φ
DQ887768.1	<i>Bos indicus</i>			Φ
JF825058.1	<i>Bos indicus</i>			\ddagger
FM179472.1	<i>Bos indicus</i>			\ddagger

Appendix 5.3: Twenty-three microsatellite markers designed and endorsed by the Food and Agriculture Organizations (FAO) commission on genetic resources for food and agriculture (2011) that are suitable for estimating genetic diversity of wild banteng. These markers were preliminarily tested on Bornean banteng faecal DNA for the first time to my knowledge. The aim was to develop three multiplexes for alleles scoring to estimate genetic diversity using the nuclear genome to corroborate genetic diversity estimated from the mitochondrial (mtDNA) genome. This information is presented to show the potential for conducting further molecular investigations on genetic diversity, sex-biased dispersal and male population structure using nuclear DNA, and also to contrast or corroborate genetic diversity and structure estimated using mtDNA.

Locus	Chromo.	Primer sequence (5'→3')		Repeat motif	Motif type	FAO Tm (°C)	GenBank accession number	Allelic range (bp)
		Forward	Reverse					
HEL9 (D8S4)	8	CCCATTCAGTCTTCAGAGGT CACATCCATGTTCTCACCAC		tgtgtgtgtg tgtgtgtgtg tgtgtgtgtg tgtgtgtgtg	di	52-57	X65214	141-173
CSSM66 (D14S31)	14	ACACAAATCCTTTCTGCCAGCTGA AATTTAATGCACTGAGGAGCTTGG		cacacacaca cacacacaca	di	55-65	n/a	171-209
CSRM60 (D10S5)	10	AAGATGTGATCCAAGAGAGAGGCA AGGACCAGATCGTGAAAGGCATAG		acacacacac acacacacac acacacacac	di	55-65	n/a	79-115
ETH3 (D19S2)	19	GAACCTGCCTCTCCTGCATTGG ACTCTGCCTGTGGCCAAGTAGG		gtgtgtgtgt gtgtgtgtgt gtgtgtgtgt gtgtgtgtgt	di	55-65	Z22744	103-133
HEL1 (D15S10)	15	CAACAGCTATTTAACAAGGA AGGCTACAGTCCATGGGATT		cacacacaca cacacacaca	di	54-57	X65202	99-119
INRA063 (D18S5)	18	ATTTGCACAAGCTAAATCTAACC AAACCACAGAAATGCTTGGAAG		cacacacaca cacacacaca	di	55-58	X71507	167-189
HAUT27 (D26S21)	26	AACTGCTGAAATCTCCATCTTA TTTTATGTTCATTTTTGACTGG		cacacacaca cacacacaca	di	57	X89252	120-158

SPS115 (D15)	15	AAAGTGACACAACAGCTTCTCCAG AACGAGTGTCTAGTTTGGCTGTG	cacacacaca cacacacaca cacacacaca cacacataca cacacacaca	di	55-60	FJ828564	234-258
TGLA227 (D18S1)	18	CGAATTCCAAATCTGTTAATTTGCT ACAGACAGAACTCAATGAAAGCA	unknown	di	55-56	NW_005405570	75-105
INRA032 (D11S9)	11	AAACTGTATTCTCTAATAGCTAC GCAAGACATATCTCCATTCCTTT	cacacacaca tacacacaca cacacacaca*	di	55-58	X67823	160-204
ETH10 (D5S3)	5	G TTCAGGACTGGCCCTGCTAACA CCTCCAGCCACTTTCTCTTCTC	acacacacac acacacacac acacacacac	di	55-65	Z22739	207-231
TGLA122 (D21S6)	21	CCCTCCTCCAGGTAATCAGC AATCACATGGCAAATAAGTACATAC	unknown	di	55-58	n/a	136-184
BM1818 (D23S21)	23	AGCTGGGAATATAACCAAAGG AGTGCTTTCAAGGTCCATGC	tgtgtgtgtg tgtgtgtgtg tgtgtgtatg	di	56-60	G18391	248-278
BM1824 (DS1S34)	1	GAGCAAGGTGTTTTTCCAATC CATTCTCCAAGTCTCCTTG	unconfirmed	di	55-60	G18394	176-197
ETH152 (D5S1)	5	TACTCGTAGGGCAGGCTGCCTG GAGACCTCAGGGTTGGTGATCAG	unconfirmed	di	55-60	G18414	181-211
ETH225 (D9S1)	9	GATCACCTTGCCACTATTCCT ACATGACAGCCAGCTGCTACT	unconfirmed	di	55-65	Z14043	131-159

HAUT24 (D22S26)	22	CTCTCTGCCTTTGTCCCTGT AATACACTTTAGGAGAAAAATA	unconfirmed	di	52-55	X89250	104-158
HEL5 (D21S15)	21	GCAGGATCACTTGTTAGGGA AGACGTTAGTGACATTAAC	unconfirmed	di	52-57	X65204	145-171
HEL13 (D11S15)	11	TAAGGACTTGAGATAAGGAG CCATCTACCTCCATCTTAAC	unconfirmed	di	52-57	X65207	178-200
ILSTS005 (D10S25)	10	GGAAGCAATGAAATCTATAGCC TGTCTGTGAGTTTGTAAGC	unconfirmed	di	54-58	L23481	176-194
INRA037 (D10S12)	10	GATCCTGCTTATATTTAACCAC AAAATTCCATGGAGAGAGAAAC	unconfirmed	di	57-58	X71551	112-148
MM12 (D9S20)	9	CAAGACAGGTGTTTCAATCT ATCGACTCTGGGGATGATGT	unconfirmed	di	50-55	Z30343	101-145
TGLA126 (D20S1)	20	CTAATTTAGAATGAGAGAGGCTTCT TTGGTCTCTATTCTCTGAATATTCC	unconfirmed	di	55-58	n/a	115-131

Appendix 5.5: Selected microsatellite markers taken from the Food and Agriculture Organization of the United Nations (FAO) guidelines (2011). PCR annealing temperature, microsatellite marker dyes and multiplexes were developed for faecal DNA of Bornean banteng. Preliminary allele sizes were estimates from dilution series of markers.

Marker name	T _m (°C)	Preliminary min. allele size (bp)	Preliminary max. allele size (bp)	Dye	Multiplex number
CSSM66	68	94	98	FAM	1
SPS115	62	112	144	HEX	
HAUT27	57	130	132	TAM	
ETH10	55-57*	128	134	PET	
HAUT24	53	100	108	FAM	2
BM1818	58	249	255	FAM	
HEL9	60	142	146	HEX	
BM1824	62	175	177	TAM	
TGLA122	54	153	157	PET	
ETH3	62	110	118	FAM	3
HEL1	56	103	117	HEX	
INRA063	57	163	177	TAM	
CSRM60	62	91	95	PET	

Appendix 5.6: mtDNA sequences of banteng in Sabah sorted according to a combination of four forests: TWR (Tabin Wildlife Reserve), USMFR (Ulu-Segama Malua Forest Reserve), MFR (Malua Forest Reserve) and MBCA (Maliau Basin Conservation Area), eight herds and six haplotypes for each sex. Duplicate sequences of both sexes for all forest/herd/haplotype combinations were removed and/or were not available (*) which resulted in a restricted data set of 21 sequences (√) which were used to compute diversity parameters for scenario 3.

Sampling location	Herd No.	Sex	Haplotype 1	Haplotype 2	Haplotype 3	Haplotype 4	Haplotype 5	Haplotype 6
TWR	Herd 1	M	√	√	√	√	*	*
		F	*	*	√	*	*	*
	Herd 2	M	√	*	√	*	*	*
		F	*	*	√	*	*	*
	Herd 3	M	*	*	√	*	*	*
		F	*	*	*	*	*	*
	Herd 4	M	√	*	*	*	*	*
		F	*	*	*	*	*	*
USMFR	Herd 5	M	√	*	√	*	*	*
		F	*	*	*	*	*	*
MFR	Herd 6	M	*	*	√	*	*	*
		F	√	*	*	*	*	*
	Herd 7	M	*	*	*	*	*	*
		F	√	*	√	*	√	√
MBCA	Herd 8	M	√	*	√	*	*	*
		F	√	*	*	*	*	*

Appendix 5.7: Results of amplification success of molecular sex markers on the Y chromosome and percentage success of six repeats conducted for each sample, and acquisition of the full concatenated mtDNA sequence/genotype. A male was identified by amplification of two fragments and a female by one fragment. Some samples of old faeces were collected but not tested due to old age and prolonged UV exposure (denoted by: x). One sample was stored in RNAlater (*) whereas all others were stored in the two-step ethanol/silica gel method. Non-amplification of any fragment indicated PCR failure and possibly indicative of poor quality DNA or insufficient yield. The male fragment was more difficult to amplify due to the larger fragment size; amplification failure often resulted in a visible single band, potentially misinterpreted as a female but only if an insufficient number of repeats were conducted. For this reason six repeats were used.

Sample ID	Amplification success			Sex	Genotype acquired
	Failed	Male	Female		
TWR21		83.3%	16.7%	Male	Yes
TWR22		100.0%		Male	Yes
TWR23	16.7%	66.7%	16.7%	Male	Yes
TWR24		66.7%	33.3%	Male	Yes
TWR25	50.0%	50.0%		Male	No
TWR26		50.0%	50.0%	Male	No
TWR27	33.3%	33.3%	33.3%	Male	No
TWR28	83.3%	16.7%		Male	No
TWR29	66.7%		33.3%	Female	No
TWR30	50.0%	16.7%	33.3%	Male	No
TWR31	16.7%	83.3%		Male	Yes
TWR32		66.7%	33.3%	Male	Yes
TWR33	16.7%	83.3%		Male	Yes
TWR34	50.0%	16.7%	33.3%	Male	No
TWR35	83.3%		16.7%	Female	No
TWR36	100.0%			n/a	No
TWR37	33.3%		66.7%	Female	Yes
TWR38	100.0%			n/a	No
TWR39	83.3%		16.7%	Female	Yes
TWR40	83.3%		16.7%	Female	No
TWR41	50.0%		50.0%	Female	Yes
TWR42	83.3%	16.7%		Male	Yes
TWR43	16.7%	83.3%		Male	Yes
TWR SRP*	16.7%	66.7%	16.7%	Male	Yes
TWR44			100.0%	Female	Yes
USMFR1	16.7%	66.7%	16.7%	Male	Yes
USMFR2	50.0%	16.7%	33.3%	Male	Yes
USMFR3	33.3%	16.7%	50.0%	Male	Yes
USMFR4	16.7%	33.3%	50.0%	Male	Yes
USMFR5		83.3%	16.7%	Male	Yes
USMFR6	50.0%	16.7%	33.3%	Male	No

Continued.

MBCA1		50.0%	50.0%	Male	No
MBCA2		50.0%	50.0%	Male	Yes
MBCA3		66.7%	33.3%	Male	Yes
MBCA4		100.0%		Male	Yes
MBCA5			100.0%	Female	Yes
MBCA6		100.0%		Male	Yes
MBCA7		100.0%		Male	Yes
MBCA8		33.3%	66.7%	Male	Yes
MBCA9		50.0%	50.0%	Male	Yes
MBCA10		33.3%	66.7%	Male	Yes
MBCA11	16.7%		83.3%	Female	Yes
MBCA12	33.3%	66.7%		Male	Yes
MBCA13	33.3%	66.7%		Male	Yes
MBCA14		83.3%	16.7%	Male	Yes
MBCA15	50.0%	33.3%	16.7%	Male	Yes
MBCA16		100.0%	0.0%	Male	Yes
TOTAL:	1333.3%	2066.7%	1300.1%		

Chapter 6: General discussion

6.1 Overview

This study provided the first baseline data on the Bornean banteng, a taxon that is seldom encountered in the wild. I tested a range of hypotheses that were designed to address the gaps in the knowledge of the species that are essential for conservation and management of the Bornean banteng. I present the aims, hypotheses and a brief summary of my findings and the conservation implications in Table 6.1. Locating a low-density and shy species in a huge expanse of tropical rainforest, and collecting sufficient data using non-invasive techniques that were not biased by human-error was exceptionally challenging. When this study was initiated, limited information was available on the Bornean banteng; brief descriptions in identification guides, a qualitative survey, and brief references to the species in a few journal articles. Chapter 2 is the first account of the natural history of the Bornean banteng. As the banteng has not been extensively surveyed, Chapter 3 tests the efficiency of two non-invasive survey methods, and estimates preliminary population sizes by accounting for identification heterogeneity using traditional non-parametric estimators. Chapter 4 investigates the activity patterns in three secondary forests and the expression of thermo-stress in activity budgets consequential of habitat modification from extensive logging over successive decades. Chapter 5 uses non-invasively sampled mitochondrial DNA (mtDNA) to investigate the ancestral lineage of banteng in relation to other *Bos* species, and estimate population genetic structure and genetic diversity. The conclusions of this thesis outlined below make a significant contribution to the conservation of the banteng because they further the knowledge of this little-known taxon, they provide suitable methodology for future surveys and because they provide the first baseline data, which will underpin the first action plan for banteng in Sabah.

6.2 The natural history of banteng

Acquiring information on the Bornean banteng was exceptionally difficult due to limited availability of published and unpublished information that was not easily accessible. I found confusion in the taxonomic description of the Bornean banteng (*Bos javanicus lowi*), with it incorrectly listed as the Burmese or mainland banteng (*Bos javanicus birmanicus*) on the map in the IUCN Red List of Threatened Species (Timmins et al., 2008). The Bornean banteng is considered endemic to Borneo and a separate subspecies. This is based on a phylogeny of

mtDNA (Matsubayashi et al., 2014) and on palaeontological evidence in the form of prehistoric cave paintings and bone fragments (Chazine 2005; Medway 1964).

Table 6.1: A summary of the aims and hypotheses and the results and implications for the conservation of banteng, their habitat and the ecosystem which are detailed according to each chapter in this thesis.

Chapter	Aims	Hypothesis	Result	Conservation implications
Chapter 2	Describe natural history	a) Collate literature b) Identify gaps in knowledge	Extensive species account. Data absences on activity, habitat use, effect of logging, and molecular description.	Increased knowledge. Identified gaps in knowledge essential for conservation.
Chapter 3	Identify effective survey methods and estimate population size	a) Camera traps are superior to sign surveys b) Effect of environmental conditions c) Identify individuals d) Population size and effect of identification heterogeneity e) Additional sampling effort required f) Population sizes	Camera traps more effective but less consistent than signs due to malfunction. General lower success of sign surveys than camera traps. Photo-identification resulted in creation of 34 individual ID profiles. Small clustered populations. Identification increases accuracy of population size estimates. Shorter surveys are possible when 3/4 of all individuals are identified. 16-25 individuals in 18km ² within Malua and 27-53 individuals within 27km ² in Tabin.	Camera traps more suitable for future surveys. Camera traps more suitable for future surveys. Banteng individuals can be distinguished even though they do not have unique pelage. Population estimates more accurate with identification of individuals. Min. 40 days survey period when using identification. Very small population sizes that will require protection to ensure their long-term survival in the wild

Continued.				
Chapter 4	Characterise activity patterns Effect of habitat disturbance upon activity budgets and site use	a) Diel activity patterns	Activity varied with post-logging regeneration age.	Logging practices should minimise disruption to wildlife behaviour.
		b) Diel temperatures of three different logged forests	Prolonged high temperature higher in recently logged forest.	Logging dramatically alters ecosystem. High temperatures may promote forest fires. Reduced impact logging needs larger uptake.
		c) Expression of thermo-stress	Strong negative relationship between activity and temperature in recently logged forest.	Logging increased food availability but stress and possible reduction in immunity and fitness
		d) Activity budgets and forest use	Energetic activities curtailed in hot temperatures and open canopy. Travel conducted throughout day under closed canopy in very old logged forest.	Continuous canopy cover essential for reducing stress. Man-made within-forest foraging sites may be beneficial for conservation.
		e) Habitat encroachment and hunting	Fishing, sandalwood collection and hunting recorded in all forests along logging roads, rivers, and in the forest	Logged forest facilitates hunting and increases human-wildlife conflict. Banteng is vulnerable due to their use of old logging roads. Reduced impact logging should limit creation of road networks.
Chapter 5	Identify population genetic structure	a) Ancestral lineage of Bornean banteng in relation to <i>Bos</i>	Bornean banteng form separate clade with guar and are distinct from other banteng subspecies	Bornean banteng should be recognised as separate subspecies. Banteng colonised Borneo circa 341 kya.
		b) Number of haplotypes in four forest reserves	Two common and four low-frequency haplotypes. Star phylogeny suggests population expansion	Identify haplotypes of other banteng in different forests, which may increase haplotype diversity.
		c) Genetic diversity	Low genetic diversity not correlated with geographic distance. Evidence to suggest population expansion.	Low genetic diversity compared to other taxa. Further work using microsatellite markers required to assess nuclear diversity and structure.
		d) Conservation management units	Evidence suggests two management units that can be managed separately.	Low-frequency haplotypes split into two management units, which should be better protected.

Prior to widespread logging and land conversion, the Bornean banteng was previously distributed across Sabah (Davies & Payne 1982). The present study did not intend to confirm the persistence of all historic records of herds identified by Payne and Davies (1982) but I was able to present new information on their status that dates back over 40 years, by creating collaborations and by conducting surveys as part of another banteng survey (P. Gardner, unpublished). Sadly, the results suggest that the extinction of banteng has occurred in at least four of these historic locations over the past three decades; Dent Peninsula (Lahad datu), Kinabatangan Wildlife Sanctuary, Silabukan Forest Reserve, and Madai-Baturong Forest Reserve. The information presented in the subsequent chapters may, however, which aid conservation of the remaining population.

Logging of primary and secondary forest in Sabah continues in the present day. This reduces habitat availability, increases fragmentation and facilitates human access to previously remote areas. In Sabah, some sustainably-logged forest reserves that containing banteng are classified as protected against logging for a predefine period (e.g. 50 years in Malua Forest Reserve). Here, ad-hoc camera trapping is currently being used to monitor the banteng population and monitoring is conducted to prevent encroachment of human activities and disturbance. In other forest reserves (Sipitang Forest Reserve), clear-fell harvesting of timber continues to remove banteng habitat, and this may potentially isolate the banteng population in the west of Sabah. In wildlife reserves (Tabin and Kulamba) in the east of Sabah, the forest is strictly protected and they are conserved primarily for the preservation of wildlife and wildlife habitat. Here, patrols and monitoring by the Sabah Wildlife Department prevents wildlife crime. Elsewhere in Sabah, banteng are incidentally monitored and protected through non-invasive surveys for other wildlife, training of rangers in survey techniques, and/or conservation of the ecosystem which are conducted by various organisations (WWF-Malaysia, Stability of Altered Forest Ecosystems (SAFE) project, HUTAN-Kinabatangan Orang-utan Conservation Programme (HUTAN-KOCP), Yayasan Sabah Foundation, Malua BioBank Ltd, and Universiti Malaysia Sabah). The government-run Sabah Wildlife Department and Sabah Forestry Department also monitor wildlife, and conduct patrols, road blocks and enforce the no-hunting policy. Despite all these efforts, a more-focused approach is required to prevent the hunting of banteng for meat and horn which continue to threaten them with extinction.

6.3 Non-invasive survey methods and preliminary population size estimation

The use of camera traps was advantageous for detecting the Bornean banteng because they provided information on presence/absence and more insightful information on individual recognition and population demography (O'Connell et al., 2011). This method is more effective compared to sign surveys, which were arduous to conduct and sometimes unproductive. For this reason, the use of camera traps for future banteng surveys is advocated. I found the survey duration to be super optimal when three-quarters of all individuals can be identified. This may suggest that future camera trap surveys can be shorter than 90 days and may still provide a robust estimation of population size within the study area. Within Malua, I estimated a small clustered population that comprised 16-25 individuals within a survey area of 18km², whereas the population size of Tabin was slightly larger at 19-53 individuals within 27.5km². Frequent photographic recaptures of individuals of both sexes suggested that banteng travelled long distances of at least 10km, yet exhibited fidelity to foraging grounds. For this reason, future studies with a clustered sampling scheme must account for autocorrelation of individuals when estimating population sizes. This can be achieved at the study design level by increasing sampling distances and by using photographic capture-recapture of identified individuals. Additional information on home-range size and daily travel distances are essential for improving the accuracy of banteng population estimates, and this information would be useful for identifying the areas of a forest reserve that are potentially used by banteng, which are essential for conservation.

6.4 Activity patterns and thermo-regulated behaviour

Chapter 4 presents the first estimate of banteng diel activity patterns, the effect of a modified forest structure upon activity budgets, and observations of illegal activity. Collaborations with other researchers and agencies were a successful method of obtaining the largest data set on banteng so far, which spanned over 46,000 camera trap nights across six years. This data set was exceptionally challenging to analyse because it was characterised by unequal sample sizes, missing values, and temporal autocorrelation (Sollmann et al., 2013). Care was taken to reduce error by defining spatial and temporal independence of camera trap events, and by discounting data of the same individual/herd over successive hours by using photo-identification. Banteng experience higher thermo-stress in forests that were recently logged and had little time to regenerate the canopy leaf cover. Logging activity increased exposure

of the soil which gave rise to high ambient temperatures that exceeded 40°C in some instances. These temperatures may increase the risk of forest fires. Banteng mitigate temperature changes and modification of the forest by decreasing the duration spent in open canopy during hot hours and by curtailing energetic activities. Old logging roads provide an abundance of suitable forage. However, they also facilitate encroachment by armed hunters, therefore increasing the potential for human-wildlife conflict. As banteng spend long durations foraging along old logging roads they are increasingly at risk of extermination.

6.5 Population genetic diversity of Bornean banteng

Chapter 5 investigated the ancestral lineage of Bornean banteng to confirm their taxonomic delineation, and to estimate the population genetic structure and genetic diversity across the Sabah landscape using non-invasively collected faecal DNA. I present the first attempt to apply sexing markers to non-invasive faecal DNA of banteng, and I also successfully designed four pairs of mtDNA markers. These markers amplified four overlapping fragments, which were sequenced in both forward and reverse direction, and therefore increased the chance of identifying true haplotypes and increased the accuracy of genetic diversity assessment. I estimated coalescence between the Bornean banteng and gaur (*Bos gaurus*) between 217 and 634 kya, which is consistent with low sea levels and a land bridge connecting Malaya and the Malayan archipelago during the Pleistocene (Voris 2000; Cannon et al., 2009; Bird et al., 2005). This may suggest that conditions were suitable for banteng migration into Borneo. The star-like haplotype phylogeny and deviation from Tajima's neutrality test may indicate that colonisation of Borneo may have been by a few founder individuals and that a population expansion subsequently occurred. I found limited genetic structure within the Bornean banteng population, with the six haplotypes distributed fairly evenly across the landscape suggesting that rivers and steep hills were not a barrier to dispersal. Four low-frequency haplotypes were confined to two forest reserves (Malua Forest Reserve and Tabin Wildlife Reserve); Malua is connected to other forest reserves containing banteng whilst Tabin is isolated. The presence of low-frequency and potentially rare haplotypes increase the diversity of the banteng, and loss of these would result in a genetically-depauperate species. Prevention of their loss is paramount to maintaining genetic diversity and long-term survival of banteng in the wild.

Based on the assessment of genetic diversity, I suggest the banteng population could be managed as two separate units: 1) The central forest reserve, a large continuous patch of

forest comprising Malua Forest Reserve, Ulu-Segama Malua Forest Reserve and Maliau Basin Conservation Area and all the forest reserves in-between that are south of the Kinabatangan River and north of the interior highway connecting Lahad datu/Tawau/Nabawan districts. 2) Tabin Wildlife Reserve, a large patch of forest isolated predominately by palm oil plantations and a main highway from the central forest reserve.

6.6 Implications for conservation of banteng

With the knowledge that camera traps are a suitable survey method for banteng and that individuals can be identified using unique markings and scars, future surveys in other forests may be more effective. Using this information, it is now possible to estimate the present-day population size in Sabah, and identify the presence of small isolated populations and assess the requirement for heightened protection by the Sabah Wildlife Department.

Banteng are tolerant of habitat disturbance when eradication of their habitat is not complete and when they are able to seek refuge in neighbouring undisturbed forest. With this in mind, logging should be conducted in a way enabling wildlife to disperse safely away from the disturbance into other forest and is not pushed into isolated forest patches. Past logging practices have severely modified the forest, leaving behind extensive networks of logging roads that increase human-wildlife conflict and exposing the soil which increases in the ambient temperature. These environmental changes cause the banteng to alter their behaviour so that they can mitigate the detrimental effects of thermo-stress and predation. Reducing the severity of human-wildlife conflict and thermo-stress may be facilitated by capping the amount of timber extracted, limiting the length and width of logging roads created, and by limiting the use of heavy machinery causing soil impaction. Reduced impact logging supposedly accounts for these factors however it is only practised on a small scale in Sabah. I suggest two measures for a future study which may serve as an alternative indication of sustainable logging: 1) wildlife activity patterns and activity budgets over a time-gradient from pre-logging to post-logging, and 2) the levels of hunting documented before, during and after logging activity, including the hunting activity by logging contractors themselves.

Core issues hindering the conservation of banteng would appear to be: 1) a lack of basic ecological information on the banteng to underpin an action plan, 2) a lack of responsiveness to protect the species and its natural habitat when their decline was first highlighted over three decades ago, and 3) empowerment of rangers to enforce the 1997 Sabah Wildlife Conservation Enactment 1997. This study provides the first baseline data on the Bornean

banteng which will underpin an action plan for Sabah. At present, banteng are conserved by their ‘Totally Protected’ status under Schedule 2 of the 1997 Wildlife Conservation Enactment (WCE), which stipulates a maximum financial penalty of RM 50k (£9,200) and/or 5 years imprisonment for death of an animal. 49 of these penalties have been imposed since 2012 (Mohd-Azlan 2012), however to my knowledge, none were for banteng despite evidence which suggested losses of banteng had been sustained during this study. Elsewhere in southeast Asia, evidence of decline in the other banteng subspecies was substantiated by extermination of >500 banteng, and confiscation of banteng artefacts (3 pairs of horns) that were on-route to Vietnam via Cambodia (Kampong Cham) (The Wildlife Trade Monitoring Network, 1997-2014). To prevent the complete extermination of this already rare species, habitat destruction and human-driven mortality for meat and horn must be immediately curtailed. Whilst it may be unrealistic to suggest increased protection for all forests containing banteng, protection of isolated populations and forest vulnerable to hunting may be enhanced. Protection of the areas containing the low-frequency haplotypes identified in the two molecular management units is essential; the central forest reserve and Tabin Wildlife Reserve (Figure 6.1). At present genetic diversity is sufficient to manage these populations separately. However, connectivity through reforestation of wildlife corridors may be essential to link banteng populations in the future. Translocation of banteng is exceptionally difficult owing to the fact that they are rarely seen and are highly sensitive to human presence. Furthermore, at present individuals with low-frequency haplotypes cannot be visually distinguished so translocation of these is not possible. Identifying the haplotypes of other banteng in Kulamba Wildlife Sanctuary nearby to Tabin, and the banteng in Kalabakan Forest Reserve and Sapulut Forest Reserve that are adjacent to the central forest reserve may increase genetic diversity. Increased protection of the banteng population and also the low-frequency haplotypes could be facilitated but would require stakeholders to be proactive. Many reserves in Sabah comprise vast areas of dense forest that are difficult to access; generally speaking the borders are difficult to monitor as road access is limited. Due to the size of a banteng carcass, removal from the forest requires some coordination. Previously, banteng carcasses have been extracted by a group of villagers (Sipitang), by boat (Malua), by 4x4 vehicles (Malua), and by using an excavator or logging machinery (Kinabatangan/Sukau/Sipitang). Whilst hunting on foot is difficult to regulate, roads and rivers into forests are slightly easier as access points are more limited. At present, gate access is tightly controlled in Maliau with a manned checkpoint. The status of the other checkpoints into Maliau is currently unknown. In Tabin, the northwestern gate is unmanned but very

secure with access tightly controlled by the adjacent plantation and is a good example of cooperation between stakeholders, however the main southwest gate is rarely locked and hunting vehicles frequently enter through here (Figure 6.2). A small gate situated along the southwest access road is also less secure, and has been unlocked by plantation workers to facilitated hunting from a 4x4. The east border of Tabin is adjacent to a large plantation and access into this plantation is regulated by security staff, however the hunting of banteng is conducted within this plantation and banteng meat is reportedly sold at the plantation market. Gate infrastructure in Malua is more extensive, with check points situated on all sides of the reserve.

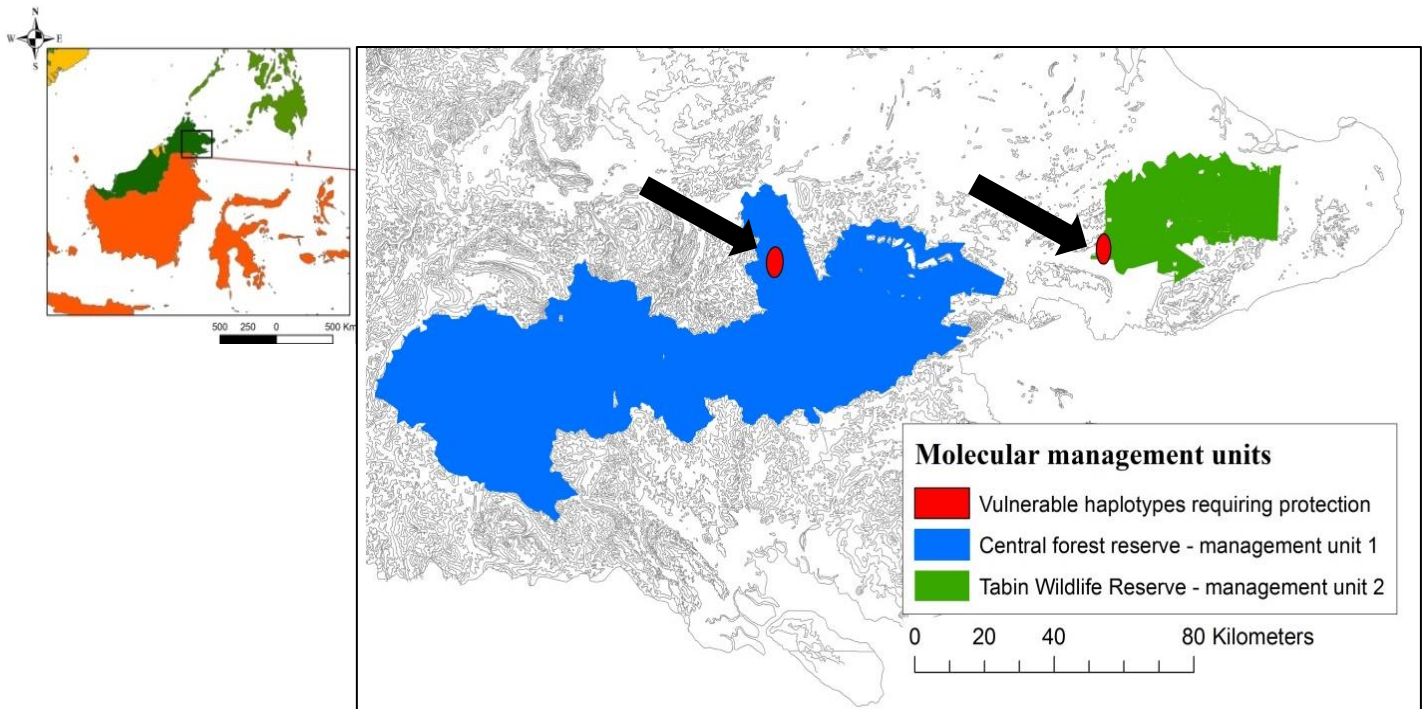

Figure 6.1: Map of Borneo (inset) and the distribution of two banteng molecular management units (right), the central forest reserve south of the Kinabatangan River, and Tabin Wildlife Reserve, based on the occurrence and locations of four low-frequency haplotypes which are vulnerable to eradication from hunting.



Figure 6.2: (Left) Photograph of the secure northwest gate into Tabin that is unmanned but maintained and tightly regulated by a palm oil plantation and is a good example of cooperation between stakeholders. (Right) Photograph of the main gate leading to the southwest border of Tabin that is left unlocked and therefore facilitates access to armed hunters using vehicles and motorbikes.

However, they are frequently left unmanned due to a limited number of staff. Intimidation of checkpoint staff and physical assaults on rangers by hunters has occurred in the past and has serious consequences for staff safety and wellbeing, morale and also for wildlife conservation. The number of rangers licenced to use firearms is few and secure facilities to store firearms are not available within check points. In 2015, a new mobile enforcement unit will circulate Sabah and will conduct random checks on markets and support forest rangers in the prevention of hunting, wildlife trade and bush meat. The following proactive measures are suggested to prevent further losses of banteng and to secure the current infrastructure:

1. The main access gate on the southwest border of Tabin is locked at dusk and reopened at dawn, with access regulated by the Sabah Wildlife department staff in Tabin. As the gate infrastructure is currently in place, minimal financial investment is required.
2. A new self-sufficient and secure checkpoint installed at the main entrance of Tabin Wildlife Reserve to regulate access and to prevent hunting. This may also help regulate the human-elephant conflict which occurs in this area when elephants disperse out of the Tabin main gate.
3. Firearms training and personal protection for rangers that work in the forest on a daily basis, secure storage for firearms, and more frequent armed patrols by existing rangers, particularly before the Muslim festival Hari-Raya when hunting for bush meat intensifies.
4. Trialling of rigorous close circuit television (CCTV) equipment at river and road checkpoints that are energy-independent units and can be accessed remotely, thereby facilitating site surveillance when rangers are deployed elsewhere.
5. Harness the intrinsic value of the banteng by exploring grassroots ecotourism initiatives particularly in locations where poverty has been identified as a major issue (e.g. Bengkoka Forest Reserve in Pitas Sabah Forestry Department, 2008) and where homestay programmes are already available (e.g. Dagat village in north Tabin), and also high-end ecotourism where bespoke accommodation and infrastructure are currently in place (e.g. Maliau Basin Conservation Area, Borneo Rainforest Lodge and Tabin Wildlife Resort). This may increase the public profile of banteng, promote *in-situ* conservation, and generate funds for conservation.

6.7 Future work

Identifying the presence of historical herds located in 1982 by Davies and Payne is essential if we are to know the remnant population size of banteng in Sabah, the extent of their present-day distribution, and their vulnerability to hunting, encroachment and deforestation. Banteng in other forests may increase the known genetic diversity within Sabah which may be managed to maintain their long-term survival in the wild. In 2012, funding was secured for a three year project which aims to confirm the remnant population of banteng in Sabah using survey methods identified by this study. To date, eight forest reserves have been surveyed with banteng confirmed in six of these. During these surveys, faecal samples are collected for future molecular work that will confirm the haplotypes and sexes of the individuals and estimate their genetic diversity. It is hoped that these new populations may increase the current genetic diversity that I identified during this study.

Using photographic identification of banteng, it would be worthwhile conducting a small-scale study using a capture-recapture framework to explore the dispersal distances and home-range size of the banteng. This information is essential for studies that use camera traps to estimate the population size because it will provide an indication of the minimum sampling distances required, it will reduce autocorrelation and it will open up the possibility of conducting more sophisticated analyses for estimating population parameters.

Future molecular work should include the amplification of banteng nuclear DNA using the microsatellite markers and three multiplexes designed by this study. Low amplification of faecal DNA using these markers was not cost effective and hampered optimisation. It may be beneficial to obtain a blood or tissue sample from a captive banteng (Javan banteng held by Edinburgh Zoo) to test these markers on good quality DNA before work using faecal DNA resumes.

6.8 References

- Bird, M.I., Taylor, D. & Hunt, C., 2005. Palaeoenvironments of insular Southeast Asia during the Last Glacial Period: a savanna corridor in Sundaland? *Quaternary Science Reviews*, 24(20-21), pp.2228–2242.
- Cannon, C.H., Morley, R.J. & Bush, A.B.G., 2009. The current refugial rainforests of Sundaland are unrepresentative of their biogeographic past and highly vulnerable to disturbance. *Proceedings of the National Academy of Sciences of the United States of America*, 106(27), pp.11188–93.
- Chazine, J.M., 2005. Rock art, burials, and habitations: Caves in East Kalimantan. *University of Hawai'i Press*, 44(1), pp.219–230.
- Davies, G. & Payne, J., 1982. *A faunal survey of Sabah*, World Wildlife Fund - Malaysia.
- Matsubayashi, H., Hanzawa, K., Kono, T., Ishige, T., Gakuhari, T., Lagan, P., Sunjoto, I., Sukor, J.R.A., Sinun, W. & Ahmad, A.H., 2014. First molecular data on Bornean banteng *Bos javanicus lowi* (Cetartiodactyla, Bovidae) from Sabah, Malaysian Borneo. *Mammalia*, 78, pp.1–9.
- Medway, L., 1964. Post-Pleistocene changes in the mammalian fauna of Borneo. *Studies in Speleology*, 1, pp.33–37.
- Mohd-Azlan, J., 2012. Wildlife conservation legislations in Malaysia: Evolution and future needs. In *Sustaining livelihood through prudent utilization and mangement of natural resources*. Institute of Biodiversity and Environmental Conservation.
- O'Connell, A.F., Nichols, J.D. & Karanth, K.U., 2011. *Camera traps in animal ecology: Methods and analyses*, Tokyo: Springer.
- Sabah Forestry Department., 2008. *Annual report 2008 - Mangkuwagu-Gana-Bengkoka*,
- Sollmann, R., Tôrres, N.M., Furtado, M.M., de Almeida Jácomo, A.T., Palomares, F., Roques, S. & Silveira, L., 2013. Combining camera-trapping and noninvasive genetic data in a spatial capture–recapture framework improves density estimates for the jaguar. *Biological Conservation*, 167, pp.242–247.
- The Wildlife Trade Monitoring Network, 1997. *TRAFFIC bulletin: Seizures and Prosecutions*, March, p.276.
- Timmins, R.J., Duckworth, J.W., Hedges, S., Steinmetz, R. & Pattanavibool, A., 2008. *Bos javanicus*. In: IUCN 2012. IUCN Red List of threatened species. www.iucnredlist.org. Available at: www.iucnredlist.org/details/biblio/2888/0.
- Voris, H.K., 2000. Maps of Pleistocene sea levels in Southeast Asia: shorelines, river systems and time durations. *Journal of Biogeography*, 27, pp.1153–1167.