



# Enhancing BIM-based data transfer to support the design of low energy buildings

Alexandra Cemesova

[sasacemesova@gmail.com](mailto:sasacemesova@gmail.com)

THIS THESIS IS SUBMITTED IN PARTIAL FULFILMENT OF THE  
REQUIREMENTS FOR THE DEGREE OF  
DOCTOR OF PHILOSOPHY (PhD)

Cardiff School of Engineering

Cardiff, Wales, UK

July 2013



## DECLARATION

This work has not been submitted in substance for any other degree or award at this or any other university or place of learning, nor is being submitted concurrently in candidature for any other degree or other award.

Signed: Alexandra Cemesova (candidate)

Date:

### STATEMENT 1

This thesis is being submitted in partial fulfilment of the requirements for the degree of PhD.

Signed: Alexandra Cemesova (candidate)

Date:

### STATEMENT 2

This thesis is the result of my own independent work/investigation, except where otherwise stated. Other sources are acknowledged by explicit references. The views expressed are my own.

Signed: Alexandra Cemesova (candidate)

Date:

### STATEMENT 3

I hereby give consent for my thesis, if accepted, to be available for photocopying and for inter-library loan, and for the title and summary to be made available to outside organisations.

Signed: Alexandra Cemesova (candidate)

Date:

## ACKNOWLEDGMENTS

*“When you really want something to happen, the whole world conspires to help you achieve it.”*

-The Alchemist, Paulo Coelho

First of all, I would like to thank my supervisors Christina Hopfe and Yacine Rezgui for giving me the opportunity to study for a PhD, and for all your encouragement and advice. I would especially like to thank Christina; without her kind words, edited manuscripts and encouragement this thesis would never have seen the light of day.

The PhD was jointly funded by the BRE Trust and EPSRC, so I would also like to thank them for their financial support. I would also like to mention Nick Tune from BRE Wales, and thank him for all his interest and help. Furthermore, I was fortunate enough to be involved in a project with BRE Wales with Andy Sutton, which was a great learning experience.

I would also like to thank my examiners, Tony Jefferson and Arto Kiviniemi, for taking the time to review this thesis.

During the last three years, I have been lucky enough to meet many professionals who were always very helpful and interested in my work. There are too many to name, but I would like to particularly mention Nick Newman from Bere:architects for all the case study information. For the participation in the mock-ups, I am indebted to Rob McLeod, Caroline Weeks, Gareth Selby, Elrond Burrell, Toby Rollason, and Andy Sutton. I would also like to give further thanks to Sylvain Robert, Jakob Beetz, Nick Nisbet, Bruno Fies, Michel Bohms, Michal Otreba, and Sylvain Marie. A thank you must also go to the IT department and the research office staff, especially Syd for fixing IES issues almost on a weekly basis.

Of course, the thesis would not have been as enjoyable without my friends and colleagues: Ian, Tom, Mike, Ioan, Catherine, Pawadee, Tom, Rhodri, Toby, Kat, Anghared, the various members of cake club, Ger, Gaia, Nikki, Iana, Ieuan, Laura...the list is endless so I am sorry if I have missed anyone. A special thank you goes to Apeksha: I am looking forward to many more films, wine and heart-warming occasions.

Furthermore, I will forever remain in debt to my loving family. Mum, Dad, and Marcus: thank you for all the moral support over the years, the packages and postcards, the fantastic places we have visited, and of course all the advice and

vitamins. I cannot thank you enough for everything, and above all for providing me with a great start to life. Marcus, you are the best brother a person could wish for. Babka, Dedko a Dedko Berto, dakujem za vsetky rady, ovocie, telefonaty...a hlavne pekne casy co sme spolu stravili. Marika, dakujem za vsetky zaujmave debaty a kolaciky. A Maria a Jana, na spolocene chvile v chorvatsku nezabudnem. A thank you also has to go to all of James' family; you have always made me feel very welcome, and I really have to say a huge thank you for all your help before and during the writing up of this thesis. I look forward to repaying you all with cheap skiing holidays in the south of France!

And finally James, thank you for putting up with me all these years. You were always there ready to give moral support and cups of tea, and no matter if I was happy, sad, angry...and well just about every mood there is. Thank you for being understanding and caring, especially on the long nights and early mornings when writing was tough. Lubim Ta.

## SUMMARY

Sustainable building rating systems and energy efficiency standards promote the design of low energy buildings. The certification process is supported by Building Performance Simulation (BPS), as it can calculate the energy consumption of buildings. However, there is a tendency for BPS not to be used until late in the design process.

Building Information Modelling (BIM) allows data related to a buildings design, construction and operation to be created and accessed by all of the project stakeholders. This data can also be retrieved by analysis tools, such as BPS. The interoperability between BIM and BPS tools however is not seamless.

The aim of this thesis is to improve the building design and energy analysis process by focusing on interoperability between tools, and to facilitate the design of low energy buildings. The research process involved the following: undertaking a literature review to identify a problematic area in interoperability, extending an existing neutral data transfer schema, designing and implementing a prototype which is based on the extension, and validating it. The schema chosen was the Industry Foundation Classes. This can describe a building throughout its lifecycle, but it lacks many concepts needed to describe an energy analysis and its results. It was therefore extended with concepts taken from a BPS tool, Passive House Planning Package, which was chosen for its low interoperability with BIM tools.

The prototype can transfer data between BIM and BPS tools, calculate the annual heat demand of a building, and inform design decision-making. The validation of the prototype was twofold; case studies and a usability test were conducted to quantitatively and qualitatively analyse the prototype. The usability testing involved a mock-up presentation and online surveys. The outcome was that the tool could save time and reduce error, enhance informed decision making and support the design of low energy buildings.

## LIST OF PUBLICATIONS

The following are conference papers in which the author is named:

- Cemesova, A., Hopfe, C.J., Rezgui, Y. 2013. An approach to facilitating data exchange between BIM environments and a low energy design tool. In: *BS2013*, 25-28th August.
- Cemesova, A., Hopfe, C.J., Rezgui, Y. 2013. Client-driven sensitivity analysis of the energy consumption of a Welsh office building using probabilistic climate projections. In: *BS2013*, 25-28th August.
- Gupta, A., Cemesova, A., Hopfe, C.J., Rezgui, Y., Sweet, T. 2013. Development of a solar PV simulation tool compatible with the Industry Foundation Classes. In: *BS2013*, 25-28th August.
- Cemesova, A., Hopfe, C.J., Rezgui, Y. PassivBIM – A new approach for low energy simulation using BIM. In: *ECPPM 2012*. Reykjavik, 25-27th July.
- Cemesova, A., Rezgui, Y., Hopfe, C.J. 2011. Possibilities and challenges created by a smart material in building performance simulation. In: *CIB W078 W102*. Sophia Antipolis, 26-28 October.

The author is currently involved in writing the following journal publications:

- Cemesova, A., Hopfe, and C.J. PassivBIM: Enhancing interoperability between BIM and low energy design.
- Gupta, A., Cemesova, A., Hopfe, C.J., Rezgui, Y., Sweet, T. A conceptual framework to support solar PV simulation using an open-BIM data exchange standard.

The author is also named in the following documents:

- Rezgui, Y., Cemesova, A., Hopfe, C. 2011. Building systems modeling and design challenges. In *Encyclopaedia of Life Support Systems (EOLSS)*, section: Technology, Information and Systems Management Resources. Developed under the Auspices of the UNESCO, EOLSS Publishers, Oxford, UK, [<http://www.eolss.net>]
- Cemesova, A., Rezgui, Y., Hopfe, C.J. 2010. Future Adaptability of Buildings. *BRE Trust Review*. BRE Press: Watford.

## TABLE OF CONTENTS

Declaration .....	iii
Acknowledgments .....	iv
Summary .....	vi
List of Publications .....	vii
Table of Contents .....	viii
List of Figures.....	xii
List of Tables.....	xvi
List of Symbols and Abbreviations .....	xvii
Chapter 1 Introduction.....	1
1.1 Problem Description.....	2
1.1.1 Sustainable building design .....	2
1.1.2 The financial and time-saving incentives of BIM.....	3
1.1.3 BIM and BPS .....	5
1.2 Motivating case example .....	6
1.2.1 Admiral Insurance Headquarters .....	6
1.3 Hypothesis, aims, and objectives.....	8
1.3.1 Hypothesis .....	8
1.3.2 Aims, objectives.....	8
1.4 Research Questions and methods.....	8
1.4.1 An analysis of interoperability between tools to support building design and assessment.....	9
1.4.2 Development of an extension to a data transfer schema .....	9
1.4.3 Implementation of the extension to the Industry Foundation Classes	10
1.4.4 Validation of the prototype .....	10
Chapter 2 Sustainable building rating systems and standards .....	12
2.1 Introduction .....	12
2.2 Sustainable building rating systems.....	13
2.2.1 BREEAM.....	13
2.2.2 LEED .....	16
2.2.3 BEAM Plus.....	18
2.2.4 CASBEE .....	19
2.3 Energy efficiency standards.....	20
2.3.1 The Passivhaus standard .....	21



2.3.2	MINERGIE .....	24
2.4	Comparisons of sustainable building rating systems and standards .....	25
2.5	Conclusions .....	29
Chapter 3	Review of BIM .....	32
3.1	Introduction .....	32
3.2	Worldwide BIM adoption .....	32
3.3	Benefits and challenges .....	36
3.4	Existing BIM authoring tools.....	39
3.5	Conclusions .....	41
Chapter 4	Interoperability between BIM and energy analysis tools.....	43
4.1	Introduction .....	43
4.2	Data standardisation and transformation efforts .....	44
4.2.1	ISO Step .....	45
4.2.2	Industry Foundation Classes (IFC) .....	46
4.2.3	IFD, COBie and OmniClass .....	55
4.2.4	Extensible Markup Language (XML) and XML Schema Definition (XSD) 56	
4.3	Addressing specific instances of data exchange .....	60
4.3.1	Plug-ins and add-ons .....	61
4.3.2	IFC- and gbXML-based data exchanges .....	62
4.4	Conclusions .....	69
Chapter 5	The PassivBIM system development.....	71
5.1	Introduction .....	71
5.2	Data transfer requirements of the PHPP annual heat demand calculation 72	
5.2.1	Variables in the annual heat demand calculation .....	72
5.2.2	Geometrical data needed for PHPP calculations.....	75
5.3	The PassivBIM system outline .....	76
5.4	IfcXmlEnergyAnalysisExtension.....	82
5.4.1	Identifying existing energy concepts in the IFC schema.....	82
5.4.2	Adding energy concepts to IFC.....	86
5.5	MsExcel Template Document .....	92
5.6	Java tool.....	93
5.6.1	EnergyApp .....	93
5.6.2	ExtractIfcGeometry .....	96
5.7	Conclusions .....	102
Chapter 6	PassivBIM validation and case studies.....	104

6.1	Introduction .....	104
6.2	Hannover Kronsberg.....	105
6.2.1	Overview of Case Study .....	105
6.2.2	Results and Discussion on the validation process.....	108
6.2.3	Results and Discussion on the decision informing function.....	111
6.3	Larch House.....	113
6.3.1	Overview of Case Study .....	113
6.3.2	Results and Discussion on the validation process.....	118
6.3.3	Results and discussion on the decision informing function .....	120
6.3.4	Results and discussion on developing PassivBIM interoperability ...	121
6.4	Conclusions .....	126
Chapter 7 Challenges in the implementation process.....		128
7.1	Introduction .....	128
7.2	Passivhaus standard related issues .....	128
7.3	AutoCAD Revit Architecture related issues .....	128
7.4	Conclusions .....	134
Chapter 8 Usability Testing .....		135
8.1	Introduction .....	135
8.2	PassivBIM Usability testing procedure.....	136
8.2.1	The selection of participants .....	137
8.2.2	The determination of the procedure and the creation of task scenarios 139	
8.2.3	The choice of performance measures .....	140
8.2.4	The preparation of the test materials and of the test environment ...	141
8.2.5	The design and analysis of the questionnaires.....	141
8.3	Results and discussion of the usability testing.....	142
8.4	Conclusions .....	151
Chapter 9 Conclusions and future work .....		153
9.1	Summary.....	153
9.2	Concluding remarks .....	155
9.3	Future challenges .....	157
9.3.1	Further testing.....	157
9.3.2	Sensitivity analysis and optimising capabilities.....	157
9.3.3	Extend import and export capabilities .....	157
9.3.4	Database of default or recommended values .....	158
9.3.5	Interface.....	158

References .....	159
Appendix A IFC extension.....	172
Appendix B Processing of IFC geometry .....	175
B.1 The placement and representation of IfcProduct .....	175
B.2 Transforming points and coordinate systems .....	177
B.3 Determining thermal envelope dimensions and orientations .....	185
B.3.1 External wall area .....	185
B.3.2 Extracting the floor area: IfcSlab.....	202
B.3.3 External window area: IfcWindow .....	204
B.3.4 External door area: IfcDoor.....	205
B.3.5 External roof area: IfcSlab and IfcRoof.....	205
B.3.6 Extracting the Treated floor area: IfcSpace and IfcWindow.....	211
Appendix C PHPP annual heat demand calculation .....	216
Appendix D Outline of PHPP worksheets.....	218
Appendix E Usability testing presentation.....	219
Appendix F Usability testing survey .....	223
Appendix G Participation information sheet for usability testing.....	226
Curriculum Vitae.....	228

## LIST OF FIGURES

Figure 1.1 Perceived ROI on overall investment in BIM (McGraw Hill Construction 2010b) .....	4
Figure 3.1 Different levels of maturity of BIM adoption (BIM Industry Working Group 2011) .....	35
Figure 3.2 The RIBA Plan of Work 2013 stages, adapted from (Sinclair 2013). .....	36
Figure 4.1 Different views of a building (Bazjanac and Kiviniemi 2007), where (a) shows an architectural view and (b) shows a thermal view. ....	44
Figure 4.2 The IFC2x3 architecture showing the main layers in the schema, and what sections they are explained in. Adapted from (Liebich et al. 2007). ..	48
Figure 4.3 An EXPRESS-G diagram of the IfcWindow entity, showing which are direct and indirect attributes. ....	49
Figure 4.4 The Nordic Energy Analysis MVD (Jiri Hietanen 2011) .....	53
Figure 4.5 The contents of an example XSD file, describing a wall element and three attributes. ....	57
Figure 4.6 The current and future use of BIM to simulate energy performance by (a) Green BIM practitioners and (b) non-Green BIM practitioners. Adapted from (McGraw Hill Construction 2010a). ....	60
Figure 4.7 IDEF0 diagram of the use of BIM and PHPP in Belgium (Versele et al. 2009). ....	65
Figure 5.1 A Gane-Sarson diagram showing a high level view of the data flow of the PassivBIM system. ....	77
Figure 5.2 UML case diagram of the interaction between architects, Passivhaus designers and the PassivBIM Java tool. ....	78
Figure 5.3 A UML sequential diagram showing the calculation of annual heat demand when the user enters non geometrical data and an IFC file is used for geometry. ....	79
Figure 5.4 A Gane-Sarson diagram outlining the data flow involved in the development of the main components of the PassivBIM System. The dotted arrows refer to the thesis section which describes these components in more detail. ....	81
Figure 5.5 An EXPRESS-G diagram of the energy analysis extension structure. ...	89
Figure 5.6 An EXPRESS-G diagram of the IfcEnergyResource data model. ....	90
Figure 5.7 An EXPRESS-G diagram of the proposed 'IfcDesignAlternative' entity. ..	90
Figure 5.8 The simplified description of the entity 'IfcBuildingEnergyItem' in an XSD file. ....	92
Figure 5.9 Example configurations of terraces composed of models of middle and end houses. ....	94
Figure 5.10 A plan view of possible local placements of walls with different orientations. ....	98
Figure 5.11 L-shaped connection between walls .....	99
Figure 5.12 The removal of the overhang in a roof slab. ....	101
Figure 6.1 The (a) south and (b) north façades of the terraced buildings in Hannover Kronsberg (Feist et al. 2001) .....	105
Figure 6.2 Floor plans of a middle house in the Hannover Kronsberg terraces. ....	106

Figure 6.3 North to South section view of the middle house in the Hannover Kronsberg terraces. ....	106
Figure 6.4 Two Hannover Kronsberg end houses joined together. ....	108
Figure 6.5 A comparison of the published and PassivBIM calculated heat transfer. ....	110
Figure 6.6 A single end house compared to two semi-detached buildings in a single IFC file ....	110
Figure 6.7 The heat demand of terraces based on middle and end house data. ....	111
Figure 6.8 Three scenarios (a), (b) and (c) show possible configurations terraced buildings. ....	112
Figure 6.9 The energy consumption of terraced buildings in the configurations from Figure 6.9 (a), (b) and (c). ....	112
Figure 6.10 Views of the Larch House, from the (a) South and (b) North (iPHA 2012b). ....	113
Figure 6.11 3D views of the Revit model of the Larch House from (a) North east and (b) south west. ....	114
Figure 6.12 Floor plans of ground floor (left) and first floor (right) of the Larch House ....	114
Figure 6.13 Larch House section view by cutting it from North to West. ....	115
Figure 6.14 A screenshot of the XML Template document. ....	117
Figure 6.15 The Larch House model with and without using IFC geometry. ....	119
Figure 6.16 The Larch House in alternative climates, and with/without IFC geometry ....	120
Figure 6.17 The correct installation for a window in the Larch House. ....	122
Figure 6.18 Screenshot of an XML file of the partly collapsed ' <i>IfcEnergyAnalysisModel</i> '. ....	125
Figure 7.1 The Larch House 3D views in (a) Revit and (b) the demo viewer. ....	130
Figure 7.2 The Larch House ground and first floor plans and north to west section view after importing a Revit generated IFC file back into Revit. ....	131
Figure 7.3 The Larch House south wall when windows are 0mm above floor level in (a) Revit and (b) demo viewer. ....	132
Figure 7.4 The effect of the ' <i>IfcWall</i> ' being generated by Revit for the south wall for the Larch House. Part (a) is the inside of the wall and (b) is the whole building. ....	133
Figure 7.5 The Larch House south wall when (a) windows inserted on the first floor are 1mm above floor level and (b) when the first floor boundary is changed to lie inside the wall. ....	134
Figure 8.1 The main steps in creating the PassivBIM usability test ....	137
Figure 8.2 (a) Question 1: Would you agree with the statement that the automation of some of the data input into PHPP could save you time? and (b) Question 2: Would you agree that a tool which could instantly calculate the PHPP energy demand of a BIM model would enhance the design process? ....	143
Figure 8.3 Comments on the second question. ....	143
Figure 8.4 (a) Question 3: Do you or your practice use any automation of data entry between BIM/CAD tools and energy analysis tools? and (b) Question 4: In your opinion, are some PHPP input calculations, such as the Treated Floor Area, open to interpretation and therefore error? ....	144

Figure 8.5 Comments on the third question. ....	144
Figure 8.6 Comments on the fourth question .....	145
Figure 8.7(a) Question 5: Could you envisage a tool such as PassivBIM being adopted in your practice? and (b) Question 6: Do you agree that a tool such as PassivBIM could save the user time and reduce error? .....	146
Figure 8.8 Comments on the fifth question. ....	146
Figure 8.9 Comments on the sixth question. ....	146
Figure 8.10 Question 7: Do you think that your workflow would benefit from streamlining data transfer from BIM to PHPP using PassivBIM? .....	147
Figure 8.11 Comments on the seventh question.....	148
Figure 8.12 Question 8: Illustrating the most important features of the tool.....	149
Figure 8.13 Comments on the ninth question. ....	150
Figure 8.14 Question 10: If the PassivBIM tool was adapted based on your feedback, would you consider its adoption? .....	151
Figure 8.15 Comments on tenths question. ....	151
Figure A.1 IFC Energy Extension - Page 1.....	172
Figure A.2 IFC Energy Extension - Page 2.....	173
Figure A.3 IFC Energy Extension - Page 3.....	174
Figure B.1 Different coordinate axis and their description if an IFC file .....	177
Figure B.2 a) Rotation of a point in a single coordinate system by 90° b) Same point in the coordinate system 'i' and 'j', where 'i' is defined as 'j' rotated by 90° around the z-axis. ....	181
Figure B.3 Translation and rotation of ' <i>IfcBuildingStorey</i> ' to ' <i>IfcElement</i> ' coordinate system. ....	183
Figure B.4 An example of code necessary to determine if a wall is external. ....	186
Figure B.5 Describing material layers to a wall which has a positive ' <i>DirectionSense</i> '. ....	187
Figure B.6 Local placement of wall coordinate system on a wall centreline. ....	187
Figure B.7 Buildings with walls drawn in clockwise and anticlockwise directions. .	188
Figure B.8 Plan view of walls and possible placements of local coordinate systems. ....	189
Figure B.9 The transformation of a homogenous point from the wall to world coordinate system for a north facing wall with a positive ' <i>DirectionSense</i> '. ....	190
Figure B.10 ' <i>SweptSolid</i> ' description in an IFC file.....	190
Figure B.11 The attributes of an ' <i>IfcExtrudedAreaSolid</i> ' and ' <i>IfcRectangleProfileDepth</i> '. ....	192
Figure B.12 Walls showing adjusted coordinates for the exterior face of a wall. ...	194
Figure B.13 The original Sutherland-Hodgman clipping algorithm.....	195
Figure B.14 The extended Sutherland-Hodgman clipping algorithm.....	196
Figure B.15 Different cases of polygon edges being clipped by a plane.....	198
Figure B.16 The external wall face and error added by extending walls.....	202
Figure B.17 An L-shaped connection of two walls. ....	203
Figure B.18 Inserting an ' <i>IfcWindow</i> ' into an ' <i>IfcWallStandardCase</i> '......	205
Figure B.19 Bottom floor being projected onto the z=0 plane of the ' <i>IfcExtrudedAreaSolid</i> ' coordinate system. ....	207
Figure B.20 The placement of an ' <i>IfcExtrudedAreaSolid</i> ' and an ' <i>IfcRectangleProfileDef</i> '. ....	208

Figure B.21 Points inside and outside of a clipping boundary $E_i$ , adapted from (Foley et al. 1996).....	209
Figure B.22 Thermal boundary location affecting the area of the roof needed. ....	210
Figure D.1 The relationships between different worksheets in PHPP. Source: CEPH material, BRE, 2013 .....	218
Figure E.1 Slides 1-4 of usability testing presentation.....	219
Figure E.2 Slides 5-8 from usability testing presentation.....	220
Figure E.3 Slides 9-12 from usability testing presentation.....	221
Figure E.4 Slides 13 from usability testing presentation.....	222
Figure F.1 Questions 7-10 from online survey.....	223
Figure F.2 Questions 5-7 from online survey.....	224
Figure F.3 Questions 1-4 from online survey.....	225
Figure G.1 Participant Information sheet page 1.....	226
Figure G.2 Participant Information sheet page 2.....	227

## LIST OF TABLES

Table 1.1 An outline of the thesis structure, and the related aims, research questions and research processes. ....	11
Table 2.1 Examples of tools which can be used for the BEAM Plus energy modelling (EMSD 2007 p.23; ASHRAE 2009b p.4) .....	19
Table 2.2 CASBEE assessment tools and when they are used in the building lifecycle (JaGBC 2013).....	20
Table 2.3 The top ten countries for Passivhaus certified buildings, data taken from (iPHA 2013b) .....	22
Table 2.4 A comparison between the Passivhaus, MINERGIE and MINERGIE-P standards. EPV values are only given for two building types. ....	29
Table 3.1 Examples of the benefits of BIM.....	37
Table 4.1 Interoperability between BPS and BIM tools, adapted from (Malin 2007) 67	
Table 5.1 Heat gain and loss variables in the PHPP annual heat demand worksheet. ....	74
Table 5.2 IFC entities related to the thermal domain. ....	85
Table 5.3 Property sets containing PHPP relevant properties. Properties in bold are relevant to PHPP. ....	85
Table 5.4 Existing structural analysis entities in the IFC, and the proposed counterparts for the energy analysis domain.....	86
Table 6.1 Thicknesses of building elements .....	107
Table 6.2 Building element areas calculated for various models in Hannover Kronsberg .....	109
Table 6.3 The construction of the Larch House .....	115
Table 6.4 Building element areas calculated for the Larch House .....	118
Table 6.5 Building elements characteristics before and after annual heat demand is limited to 15kWh/m <sup>2</sup> a for the Larch House .....	121
Table 6.6 Window details exported to the Window tab in PHPP .....	123
Table 6.7 Window details exported to the Windows tab in PHPP showing the calculated total area. ....	123
Table 6.8 Building element details exported to the Areas tab in PHPP .....	124
Table 7.1 True North angles calculated from IFC files of the Larch House.....	129
Table 8.1 The different categories of BIM users. ....	139
Table B.1 A point in two different coordinate systems .....	184



## LIST OF SYMBOLS AND ABBREVIATIONS

The following symbols and abbreviations have been used in this thesis:

AHP	Analytical Hierarchy Process
API	Application Programming Interface
AR4	Fourth Assessment Report
BIM	Building Information Modelling
BPS	Building Performance Simulation
BRE	Building Research Establishment
BREEAM	Building Research Establishment Environmental Assessment Method
bSI	buildingSMART International
CAD	Computer Aided Design
CASBEE	Comprehensive Assessment System for Built Environment Efficiency
CEPH	Certified European Passive House Designer
COBie	Construction Operations Building information exchange
CORENET	COstruction and Real Estate NETwork
CSH	Code for Sustainable Homes
DER	Dwelling Emission Rate
DTD	Document Type Declaration
DXF	Drawing eXchange Format
EG Science	EU Climate Change Expert Group
EMSD	Electrical & Mechanical Services Department
EPBD	Energy Performance of Buildings Directive
GSA	General Services Administration
GBS	Green Building Studio
gbXML	Green Building eXtensible Markup Language
GUI	Graphical User Interface
HK-BEAM / BEAM Plus	Hong Kong Building Environmental Assessment Method
IAI	International Alliance for Interoperability
IBIMA	Iran Information Modeling Association
IDF	Input Data File
IDM	Information Delivery Manual
IES<VE>	Integrated Environmental Solutions <Virtual

	Environment>
IFC	Industry Foundation Classes
IFD	International Framework for Dictionaries
IGES	Initial Graphics Exchange Specification
INP	Energy simulation input file
IPCC	Intergovernmental Panel on Climate Change
iPHA	International Passive House Association
ISO	International Standards Organisation
JaGBC	Japanese GreenBuild Council
KBSI	Knowledge Based Systems Inc.
LEED	Leadership in Energy and Environmental Design
LZCT	Low and Zero Carbon Technologies
NBIMS	National BIM Standard
NBS	National Building Specification
NIBS	National Institute of Building Sciences
OmniClass	OmniClass Construction Classification System
PHI	Passive House Institute
PHP	Passiefhuis-Platform
PHPP	Passive House Planning Package
PMP	Plate-form Maison Passive
RICS	Royal Institution of Chartered Surveyors
RIBA	Royal Institute of British Architects
ROI	Return On Investment
SAP	Standard Assessment Procedure
SBEM	Simplified Building Energy Model
SPF	STEP based Physical File
STEP	Standard for the Exchange of Product Model Data
IFC2x3 TC1	IFC2x Edition 3 Technical Corrigendum 1
USGBC	United States Green Building Council
VDC	Virtual Design and Construction
WBCSD	World Business Council for Sustainable Development
XML	eXtensible Markup Language
XSD	XML Schema Definition

A	Area
ACH	Air changes per hour
$A_w$	Window opening area
c	Specific heat capacity of air
EA	Energy and atmosphere
EPV	Energy performance value
BEE	Built environment efficiency
$f_T$	Reduction factor for reduced temperature differences
g	Degree of solar energy transmitted through glazing Normal to the irradiated surface
G	Total radiation
$G_t$	Temperature difference time integral
$H_T$	Length of the heating period
IEQ	Indoor environmental quality
L	Built environment load
$n_G$	Utilisation factor
$n_V$	Effective air exchange rate
PH	Passive House
Q	Built environment quality
$Q_F$	Free heat gains
$Q_G$	Useful heat gains
QH	Annual heat demand
$q_H$	Normalised annual heat demand
$Q_i$	Internal heat gains
$q_i$	Internal gains estimated for standard living conditions
$Q_L$	Total heat loss
$Q_s$	Solar heat gain
$Q_T$	Transmission heat loss
$Q_V$	Ventilation heat losses
r	Reduction factor
RQ1	Research question 1
RQ2	Research question 2
SAV	Surface area to volume ratio
TFA	Treated Floor Area
U	U-Value
WCS	World coordinate system



## Chapter 1 INTRODUCTION

There is now a general agreement that climate change is inevitable (CIBSE 2005; Jenkins et al. 2009; O'Neill et al. 2013) and that anthropogenic greenhouse gas emissions are part of the cause for the rising temperature and sea levels (Jenkins et al. 2009; IPCC 2007). Many effects of climate change have already been recorded (IPCC 2007). These include the global surface temperature rising and the occurrence of heat waves being more frequent. It is predicted that it is '*very likely*' (90% probable) that in the future there will be an increase in heat waves and heavy precipitation. The effects of climate change are in some cases already disastrous. In 2003, Central and Western Europe experienced the hottest heat wave since 1780. It is claimed that across 16 European countries, more than 70,000 deaths were a consequence of this event (Robine et al. 2008). The shifting of trends and characteristics has been attributed to the climate changing, and it is predicted to continue (CIBSE 2005; IPCC 2007).

The UK Government believes the concentration of greenhouse gasses in our atmosphere needs to be stabilised in order to mitigate climate change. In order to achieve this, the UK has legally bound itself to the Climate Change Act 2008. This states that the UK must reduce its emissions by at least 80% by 2050, relative to a 1990 baseline (UK Parliament 2008). The World Business Council for Sustainable Development (WBCSD) believes that 40% of the final energy used globally is due to buildings (WBCSD 2013). This highlights that the construction industry has an opportunity to contribute to lowering global emissions, as well as the responsibility to make sure it does.

In order to design sustainable buildings, many factors have to be taken into account such as the site, energy systems, and materials (Kibert 2013 p.189). Sustainable building rating systems can be used to analyse these areas qualitatively and quantitatively. The buildings are then labelled depending on their performance. An alternative approach is to design a building so it adheres to a certain standard. They can be either voluntary or obligatory. Building Performance Simulation (BPS) can be used for both rating systems and standards to support the design process. An integrated design approach can be taken by using information already available in a Building Information Modelling (BIM) model and using it for energy analysis calculations.

## 1.1 PROBLEM DESCRIPTION

### 1.1.1 SUSTAINABLE BUILDING DESIGN

In order for more sustainable buildings to be designed, the current practices in industry have to change. An attempt to encourage sustainable design was recently made by the Royal Institute of British Architects (RIBA) with the new RIBA Plan of Work 2013. The RIBA Plan of Work describes the key stages and activities in construction, such as ‘*Strategic Brief*’, ‘*Conceptual Design*’ and ‘*In Use*’. According to Angela Brady the RIBA Plan of Work can be used as a “*vehicle for mapping the ways in which sustainable design activities can be integrated into the design and construction process*” (Gething 2011). Consequently, the new Plan of Work 2013 includes sustainability checkpoints that need to be addressed at each work stage.

BPS tools can be used to support the RIBA work stages. BPS has been defined by Drury Crawley as “*a powerful tool which emulates the dynamic interaction of heat, light, mass (air and moisture) and sound within the building to predict its energy and environmental performance as it is exposed to climate, occupants, conditioning systems, and noise sources*” (Crawley 2003). Throughout all the design stages BPS tools can perform tasks outlined by the RIBA Work Stages, such as sustainability assessments (Azhar et al. 2009), checking compliance to Building Regulations Part L (Crawley et al. 2005) and predicting resilience to climate change (De Wilde and Tian 2012). The conceptual design stage is the point where design decisions taken can have a large impact on the energy efficiency of the final building design (Attia, Gratia, et al. 2012; Eastman 2009; Schlueter and Thesseling 2009; US GSA 2012). There is a tendency for BPS tools not to be used until a later design stage, or in some cases not until after the design process (Schlueter and Thesseling 2009). Another limitation to BPS use is the lack of features enabling comparisons of alternative designs (Attia, Gratia, et al. 2012).

Additionally, there are various sustainable building rating systems and standards available worldwide which are changing the way buildings are designed. Sustainable building rating systems are used to rate a building from various different aspects. They can promote the use of renewable technologies. One limitation is they have been found in some cases not to perform as predicted (Newsham et al. 2009). BPS is used in the certification process to calculate performance metrics such as the energy performance and daylight levels. It has been stated however that rating systems are aimed for the late design stage (Ding 2008). A consequence of this is that buildings performance will be evaluated to provide a rating, but not to iteratively

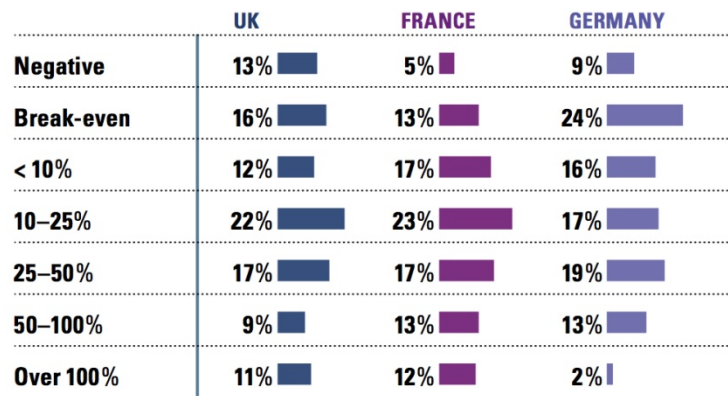
improve its energy use. Standards also rely on BPS tools, but they tend to be more specific in nature than rating systems. For example, the Passivhaus standard promotes a '*fabric first*' approach, as for example it requires buildings to be airtight, well insulated with no or limited thermal bridges, and to have triple glazed windows.

In general, there is still a great uncertainty as to what the global future emissions scenario will look like. The Intergovernmental Panel on Climate Change (IPCC) was set up in 1990 to predict future long term emission scenarios, which have been used to analyse the possible effects of climate change, and how it could be mitigated. The most recent publication on emission scenarios from the IPCC is the Fourth Assessment Report (AR4) (IPCC 2007). In this report, it is calculated that by the end of the 21<sup>st</sup> Century the temperature change could be up to 4°C in the emissions scenario '*A1FI*'. According to EU Climate Change Expert Group (EG Science) (2008) we are currently on the trajectory of the high emissions scenario. There is still time until 2020 to start cutting emissions. In short, now is the time to be designing and constructing highly energy efficient buildings, especially as buildings have a relatively long lifespan of 50-100 years (De Gracia et al. 2010).

### *1.1.2 THE FINANCIAL AND TIME-SAVING INCENTIVES OF BIM*

It is recognised that the adoption of BIM could result in many benefits, including a reduction of project cost (BIM Industry Working Group 2011). It's adoption is encouraged by the UK government, and it is requiring BIM to a certain level to be used on all its projects by 2016 (Cabinet Office 2011). Using figures from the US, it has been extrapolated that if BIM was implemented on all major projects in the UK, there could be net savings between £1- 2.5bn per year in the construction stage. Consequently, not implementing BIM sooner and at a higher level could be costing the construction industry billions of pounds.

Financial savings due to BIM have been documented worldwide. According to a SmartMarket report on the value of BIM (McGraw Hill Construction 2010b), 74% of Western European BIM users and 63% of North American BIM users reported returns on their investment in BIM. A breakdown of the perceived Return On Investment (ROI) in Western Europe is given in Figure 1.1. This shows that the average saving is in the 10-25% category, but there is a very realistic potential to have a 100% ROI. This demonstrates that companies which have not been using BIM technologies are also missing the opportunity to make a higher profit.



**Figure 1.1 Perceived ROI on overall investment in BIM (McGraw Hill Construction 2010b)**

Savings from BIM could also be viewed from the perspective of time. In 1995, the Singapore's Ministry of National Development launched the 'CO<sup>n</sup>struction and Real Estate NETwork' (CORENET). Its aim was to “achieve a quantum leap in turnaround time, productivity and quality” (Building and Construction Authority 2013). The CORENET system includes:

- An integrated submission system.
- An integrated plan checking system.
- IT standards.
- Information services.

The information system and IT standards refer to a single place online where documents can be found on: regulations, building codes, circulars and National Standards for Information Exchange in the Construction Industry. The e-submission system is used to upload all project related documents. The benefits of a central, electronic based system include that it is convenient: it allows submissions to be made and their status can be verified at any point from anywhere. The integrated plan checking system is used to review if plans comply with building regulations. This can now be done in the design phase as opposed to the approval stage, so it can save time as problems can be fixed earlier when the design is more flexible. Additionally, a designer does not have to go through the cycle of several planning applications if previous efforts are unaccepted.

The plan verifying is performed by an environment called e-PlanChecker. This includes a web interface for users so they can upload information, a viewer which



displays their model, the compliance tester and the ability to generate a report with the results (Khemlani 2005). The environment uses IFC and FORNAX technology. FORNAX had to be used to add a higher level of semantics to the IFC, as it was insufficient. The objects described by FORNAX are customisable, so any country could adapt and use the system. As a result, the environment has been adapted and used in Norway, and some pilot schemes are underway in NEW York City, Japan and Australia (Khemlani 2005).

In the UK, planning approval can take anything from 8-13 weeks to obtain, depending on the complexity of the project (Department for Communities and Local Government 2013b). This shows that automating processes using BIM technology can save time.

### *1.1.3 BIM AND BPS*

BPS tools can be used in conjunction with BIM models, to analyse performance metrics such as energy use, carbon emissions and comfort. Information necessary for the analysis such as the building geometry and properties can be extracted from the BIM model. This avoids data repetition and redundancy. For such as transaction to take place, data has to be saved in a format that is understood by the initial BIM tool and the target analysis software. Many software vendors solve this issue by simply concentrating on linking specific software. This does not however benefit the wider building simulation and design community. Efforts should instead be concentrated on developing a single neutral data transfer schema, so advances made would be beneficial to a plethora of tools.

An example of a neutral data exchange format is the Industry Foundation Classes (IFC) schema. This schema supports interoperability between different software platforms (buildingSMART 2013). The schema is large, and so a mechanism called a Model View Definition (MVD) has been developed. This enables only sections to be needed in specific data transfers. An official MVD for energy analysis is under development (Jiri Hietanen 2011), and tools such as RIUSKA and IDA ICE have been successfully tested with it (Senate Properties / Statsbygg 2011b; Senate Properties / Statsbygg 2011a). However, the MVD in question and also the IFC schema itself cannot yet describe all the concepts necessary for an energy analysis. An energy analysis data transfer needs to be able to describe input and output parameters, as well as simulation details such as length and type. A range of necessary concepts are proposed for example in the AECOO-1 Testbed project (US GSA 2009). A case for static and dynamic parameters to be stored together has

also been made by Rezgui et al. (2010). This could be one of the reasons that not all BPS tools try and become IFC compliant.

In practice, there are still many problems with interoperability in industry (Cerovsek 2011; Wilkins and Kiviniemi 2008; Grilo and Jardim-Goncalves 2010). This has been attributed to the diverse range of tools which are being used (Steel et al. 2012). Each discipline involved in the design and construction of a building has tools that they regard as critical for them to carry out their jobs (Bazjanac and Kiviniemi 2007). The task of transferring data is also not a simple case of mapping concepts between different internal data models of tools. It has been argued that there are different views of a building, and that some processing has to occur before data is suitable for a target analysis tool (Wilkins and Kiviniemi 2008). Therefore, enabling seamless data transfer between BIM and analysis tools is an active research area.

Some of the general limitations and benefits of BIM-based energy analysis have also been outlined by the US General Services Administration (GSA) in their '*BIM Guide for Energy Performance*' (US GSA 2012). This includes data transfer schemes being too flexible in how they describe objects. As a consequence, the exported shape representation of an object may differ between tools. This report also gives guidance on how building elements and spaces need to be described for a successful transfer of data, and outlines the importance of developing model-checker software. The report aims to provide best practice guidance, and similar efforts need to be undertaken by other countries.

## 1.2 MOTIVATING CASE EXAMPLE

The case study presented can be considered as motivation for the amelioration of interoperability. It relates the author's own experience of a lack of interoperability and the need to support decision making in the design process.

### 1.2.1 ADMIRAL INSURANCE HEADQUARTERS

The effect of climate change on the performance of buildings is still an active research area (De Wilde and Tian 2012; Radhi 2009; Jenkins et al. 2011; McLeod et al. 2012a; Hopfe et al. 2009; Cemesova et al. 2013). The author was involved in a TSB funded research project, in which a building's resilience to climate change was assessed (Cemesova et al. 2013; Beddoe and Sutton 2012). The building is an office block which will be the headquarters of Admiral Insurance. The study was performed in two stages. The aim of the first stage was to identify the effects of interventions to (a) the building envelope and (b) the impact of user behaviour on performance aspects such as energy consumption and thermal comfort. More

information on this stage of the research can be found in (Cemesova et al. 2013). The second stage was to provide the client with an adaptation strategy to climate change. This suggested possible scenarios in order to make the building robust for the present time, as well as for 2030, 2050 and 2080.

The research paradigm used in this work was so called '*action research*' (Oates 2006). It involved members of the multi-disciplinary design team setting up an energy analysis model of the building from building plans. One of the problems encountered was the energy model was initially set up only for building regulations compliance checking. This meant detailed information about the structural components was missing, which had to be corrected before studies on thermal mass could be performed. A range of the building properties were also left as default. As a result, meetings had to be set up with electrical and mechanical engineers to check that the model was representative of the actual building that was being planned. This included parameters such as occupancy schedules, internal gains, HVAC efficiencies and occupancy density. This shows that there is a potential for central BIM model to be used in current design practise, as it would be up to date information that would be verified by multiple domains.

The simulation work commenced during the detailed planning stage. The parameters influential to the lowering of both the current and future energy consumption were identified. These included the window specification and temperature set point of the cooling system. This information was presented to the design team. Possible current and future interventions to the building were discussed and agreed. Consequently, an adaptation strategy was defined, which included the current planned building upgrading its window specification. Eventually, the proposed change was not incorporated into the final design of the building. This trend indicated that the adaptation strategy which was designed for future years may not be followed.

This example highlights that the project team is willing to consider alternative designs based on information from BPS, but the conceptual design stage is more suitable for informing design decisions. It also shows how the current design process could benefit from integrating BIM and BPS in order to support decision making throughout the design process.

## 1.3 HYPOTHESIS, AIMS, AND OBJECTIVES

### 1.3.1 HYPOTHESIS

The hypothesis of the thesis is that **existing data transfer methods can be extended in a way to address current issues with interoperability, in order to support decision-making in sustainable building design.**

### 1.3.2 AIMS, OBJECTIVES

The aim of this thesis is to improve the building design and energy analysis process by focusing on interoperability between tools, and to facilitate the design of low energy buildings. The objectives of the thesis are therefore below:

- The first objective is to identify a problematic area in the interoperability between BIM and energy analysis tools.
- The second objective is to extend the IFC schema so it can store energy related data.
- The third objective is to implement a prototype. This should be based on the extended IFC schema which is a result of the second objective.
- The fourth objective is to present a prototype interface to the target audience. The results of this can be used to gauge the perceived need for the tool, and to determine future directions.

The main results of this thesis will be (a) an energy domain extension to the IFC schema, (b) a prototype which will be tested with case studies and (c) the analysis of the benefits and limitations of a proposed prototype, based on expert's opinions.

## 1.4 RESEARCH QUESTIONS AND METHODS

The undertaken research aims to answer the following main research questions:

**Question 1 (RQ1):** How can an *extension* to an existing data transfer schema support *building design and assessment*?

The method to answer RQ1 involves the following:

- Analysing the *interoperability* between tools used for *building design*, and tools that support *rating systems* and *standards* (Section 1.4.1).
- Developing an *extension* to the data transfer schema which addresses an *interoperability* issue (Section 1.4.2).

**Question 2 (RQ2):** How can an *extension* be used to develop a tool which supports *sustainable design*?

The method to answer RQ2 involves the following:

- Implementing the *extension* to create a prototype *tool* which can be used for *sustainable design* (Section 1.4.3).
- Validating the *prototype tool* and its proposed interface (Section 1.4.4).

All the chapter headings, summaries, relevant questions and their place in the research process are summarised in Table 1.1.

#### *1.4.1 AN ANALYSIS OF INTEROPERABILITY BETWEEN TOOLS TO SUPPORT BUILDING DESIGN AND ASSESSMENT*

In order to address RQ1, the first step involved completing a literature review which answered the following:

- What is the current state of the art in sustainable building rating systems and standards? (Chapter 2)
- How does the adoption of BIM influence building design? (Chapter 3)
- What are the challenges that need to be faced to achieve seamless interoperability between BIM and energy analysis tools? (Chapter 4)

Therefore, Chapter 2 starts by introducing sustainable building rating systems and standards. Chapter 3 follows with a description of BIM adoption, its benefits and limitations. Chapter 4 brings the two subjects together, and assesses the state of interoperability between BIM tools and those relied upon by rating systems and standards.

#### *1.4.2 DEVELOPMENT OF AN EXTENSION TO A DATA TRANSFER SCHEMA*

The IFC schema was extended with an energy analysis domain to support the transfer of energy related data (Chapter 5). The extension was based on the structure of an existing analysis domain within the schema. The energy related concepts used for the extension originate from an energy analysis tool used to design low energy buildings.

### *1.4.3 IMPLEMENTATION OF THE EXTENSION TO THE INDUSTRY FOUNDATION CLASSES*

In order to address RQ2, the extension is implemented in the form of a prototype (Chapter 5). This prototype transfers and processes data, and then calculates heat demand. Some functions which inform decision making in the design process are also included in the prototype.

### *1.4.4 VALIDATION OF THE PROTOTYPE*

The prototype was validated by analysing its ability to accurately process and transfer geometry for the purpose of energy calculations (Chapter 6), in order to answer RQ2. A case study approach is used to iteratively test and update the prototype, and eventually validate the energy calculations. The analysis is quantitative in nature. The potential of the prototype, named PassivBIM, was then validated by presenting it to the target audience and analysing their responses (Chapter 7). The responses were analysed both qualitatively and quantitatively.

After the results are discussed, conclusions from the whole thesis and recommendations for future work are given (Chapter 8).

**Table 1.1 An outline of the thesis structure, and the related aims, research questions and research processes.**

Chapter	Title	Summary	Questions to be addressed	Research Process
1	Introduction	Present hypothesis, aims and objectives, research questions, and the research methodology		Motivation and experiences.
2	Sustainable building rating systems and standards	Analyse the state in the art in the energy assessment and rating of buildings.	How can the energy efficiency of buildings be improved in the design process?	Literature review.
3	Review of Building Information Modelling	Review the current state of BIM adoption, its benefits and limitations,	Identify how the adoption of Building Information Modelling (BIM) influences building design	
4	Interoperability between BIM and energy analysis tools	Give a brief overview of data transfer efforts. Continue with a description of the current interoperability between BIM with analysis tools used by rating systems and standards.	What are the challenges that need to be faced to achieve seamless interoperability between BIM and energy analysis tools?	
5	The PassivBIM System	Identify how the IFC can be extended, and describe the implementation of the PassivBIM system prototype.	To what extent do the Industry Foundation Classes need to be enriched to support the data transfer of energy analysis concepts? How can an enriched Industry Foundation Classes Schema be used to facilitate the design of low energy buildings?	Determination of energy data transfer requirements. Design and implementation of prototype.
6	Case Studies and Validation	Describe the testing and iteratively improve the prototype.	Does the prototype accurately process and transfer geometry for the purpose of PHPP energy calculations?	Case study, quantitative data analysis
7	Usability Testing	Ascertain the possibilities of the PassivBIM from architect's and Passivhaus designer's opinions.	How is the possible application of PassivBIM perceived by potential users? What are the main limitations?	Survey, quantitative and qualitative analysis.
8	Conclusion	Summary of PassivBIM tool, findings, feedback from industry and future work.		

## Chapter 2 SUSTAINABLE BUILDING RATING SYSTEMS AND STANDARDS

Sustainable building rating systems and performance standards are introduced in section 2.1. Most referenced and widely used rating systems will be summarised in section 2.2, followed by energy efficiency standards in section 2.3. Comparisons are then made between the outlined rating systems and the standards (Section 2.4). Finally, conclusions on the main observations are summarised (Section 2.5).

### 2.1 INTRODUCTION

In the built environment, there is a range of legislation, rating systems and standards worldwide which aim at addressing the energy efficiency of buildings. Energy efficiency policies which are used in over 70 countries have been presented and evaluated in a joint project between the World Energy Council, the Agency for Environment and Energy Efficiency, and ENERDATA. It is called '*Energy Efficiency Policies and Indicators*' (World Energy Council 2008). An example of legislation is the Energy Performance of Buildings Directive (EPBD) 2002/91/EC (European Commission 2003). Part of the EPBD is that (a) the energy efficiency of new buildings should be calculated by a methodology which complies with the EPBD and (b) buildings need an Energy Performance Certificate (EPC). Rating systems (otherwise known as labelling programs) are sometimes referred to as standards (Rodrigues et al. 2012). There is however a significant difference between the two.

Sustainable building rating systems have been defined as: "*tools that examine the performance or expected performance of a 'whole building' and translate that examination into an overall assessment that allows for comparison against other buildings*" (Fowler and Rauch 2006). Rating systems can encourage the use of new technology and features (Armstrong and Henderson 2009). They are used throughout the world, and the Building Research Establishment Environmental Assessment Method (BREEAM) and Leadership in Energy and Environmental Design (LEED) are considered as the world leaders (Roderick et al. 2009). BREEAM has been used to certify over 250 000 buildings (BRE Global 2013b), whereas LEED has been used to accredit around 45 000 commercial buildings, and 19 000 residential units (USGBC 2012).

Standards are composed of highly technical guidance, which can also improve manufacturing and development (Fowler and Rauch 2006). The Passivhaus Standard is one of the fastest growing energy standards in the world, with over



40 000 buildings in existence (iPHA 2013a). Its use is not limited to just domestic or commercial buildings; it can be applied to residential, industrial, public and commercial buildings. The MINERGIE label is from Switzerland, and is targeted at France, Italy, Germany and the USA. It has been used to certify over 29 000 buildings.

According to the World Energy Council (2008) the standards and labelling programs can be complimentary to one another. The report argues that they can be used together to transform the market and slow down growing electricity demand. It has also been reasoned there are three main energy- and environment-efficient models (Carassus 2008). These are '*Energy and environment*', '*Low consumption*' and '*Energy saving and production*'. Systems such as BREEAM and LEED fall into the category of '*Energy and environment*', whilst standards such as Passivhaus and MINERGIE can be classified as '*Low consumption*'. Carassus (2008) claims the '*Energy saving and production*' category is concerned with the production of electricity through technologies such as solar photovoltaic panels. It can be argued that this third category is in some cases already addressed by standards and rating systems. For example, one of the MINERGIE standards called '*MINERGIE- A*' aims to delivery '*Nearly Zero Energy Buildings*'. Also, renewable technologies are encouraged by LEED.

## 2.2 SUSTAINABLE BUILDING RATING SYSTEMS

### 2.2.1 BREEAM

BREEAM was launched in 1990 by the Building Research Establishment (BRE) Global. It sets the standard for best practice in sustainable design. The BREEAM assessment method has also been used as a reference to develop similar schemes in countries such as the Netherlands, Spain, Norway, Germany and Sweden (BRE Global 2013b). BREEAM was also the basis of the Hong Kong Building Environmental Assessment Method (BEAM Plus). Around 370 buildings have been certified according to this new system (HKGBC 2013). The new BREEAM International New Construction standard was released in 2013. The corresponding technical manual (BRE Global 2013a) outlines the standard, and shows how the certification stages align with the RIBA work stages. The BREEAM assessment is credit based, and these are awarded in the following areas: '*management*', '*health and wellbeing*', '*energy*', '*transport*', '*water*', '*materials*', '*waste*', '*land use and ecology*', '*pollution*' and '*innovation*'. Each area is weighted, and after credits have been awarded in each area they are multiplied by this weighting factor. The resulting

section scores are summed up, and the building can be labelled using the following scores: 'Unclassified' (<30%), 'Pass' (≥30%), 'Good' (≥45%), 'Very Good' (≥55%), 'Excellent' (≥70%), or 'Outstanding' (≥85%). A sub-section of the energy area is called 'Ene 01 Energy Efficiency'. In order to gain credits for this part, an energy calculation tool compares the carbon emissions of an 'assessment' building and a 'notional' building (BRE Global 2013a). The assessment process itself has to be carried out by licensed assessors, which then produce a report. This is sent to BRE and they check its quality and then issue a BREEAM rating.

In the UK, BREEAM is split into several schemes which tackle different types of buildings. These schemes include the Code for Sustainable Homes (CSH) and BREEAM 2011 New Construction. The CSH was introduced in 2007, and is a voluntary national standard for the design and construction of homes (Department for Communities and Local Government 2013a). It rates buildings using a 1-6 star system in the following nine categories: energy/CO<sub>2</sub>, water, materials, surface water run-off, waste, pollution, health, management and well-being, and ecology. Once stars have been awarded in each category, a building is awarded a CSH level, ranging from 1-6. In some scenarios certain levels are mandatory: the CSH level 3 has been incorporated into the Building Regulations, and is required by the Homes and Community Agency for any new housing they fund. In order to achieve Level 4, the Dwelling Emission Rate (DER) must be 44% lower than the Building Regulations standard (McManus et al. 2010). The CSH has received some criticism in the past. McManus (2010) claims that the code may not be able to deliver its sustainability goals, and it may even hamper house building in the social sector where it is crucial due to the growing population.

### **Tools for BREEAM accreditation**

The energy efficiency calculation can be performed using either approved dynamic simulation models, or the Simplified Building Energy Model (SBEM).

SBEM calculates monthly energy use and carbon dioxide emissions. It complies with CEN standards, but it originates from the Dutch methodology NEN 2916:1998 (Energy Performance of Non-Residential Buildings). It has an interface which can be downloaded free of charge, iSBEM. A revised version of the tool is also available, Consultation Simple Building Energy Model (cSBEM), which takes into account the 2013 revision of the Building Regulations Part L. A variant of SBEM is also being used to assess if buildings are suitable for the Green Deal (Crown 2013). The Green Deal can be used to stagger the payment of implementing energy saving

technologies to buildings. SBEM is not intended to be used as a design tool, and cannot be used for purposes such as system sizing (Building Research Establishment Ltd. 2009).

There is a range of dynamic tools which can be used for BREEAM accreditation, which include:

- The IES<VE> tool. This is composed of many modules which perform specific tasks, such as defining model geometry or performing an energy analysis. One of these modules is called '*VE-Navigator for BREEAM 2008*', and it automates credit assessment. This module is also used by another tool in the IES family: IES TaP. This claims to streamline, manage and automate the certification process for both the BREEAM and CSH rating systems.
- DesignBuilder. This is an interface to the EnergyPlus dynamic simulation model. It can be used to gain BREEAM credits in the areas of carbon, comfort and daylighting (DOE 2013). It can also be used to perform SBEM calculations.
- AECOsim Energy Simulator. This also uses EnergyPlus. It automatically creates the baseline and budget buildings for ASHRAE Standard 90.1 (2004 and 2007) and creates energy performance data for use in AECOsim Compliance Manager for LEED 3.0 documentation (DOE 2013).
- EcoDesigner Star. This is compliant with ANSI/ASHRAE Standard 140-2007. This means it can be used to gain BREEAM credits (Graphisoft 2013a). It can also be used to directly export to iSBEM.
- Riuska. This tool has been BREEAM approved for the calculation of the '*Ene 1*' credit (Progman Oy 2013b).

A framework has been proposed by Dawood et al. (2013) where CSH and BREEAM are incorporated in the RIBA design stage. Accreditation to these assessments is part of the capabilities of a proposed tool, Sustainable Design Optimisation Tool (SDOT). The SDOT relies on building energy simulation tools to be integrated with BIM to calculate heat gain/loss and emissions. This limits the usability and applicability of the framework, as not all simulation tools are integrated with BIM. SDOT requires alternative designs from the designer(s) which can be analysed

using a Multi-Criteria-Decision-Making approach called Analytic Hierarchy Process (AHP). These designs need to be varied by:

- the building shapes and orientation,
- different type, area and orientation of windows, and
- levels of solar mass in the walls and roofing.

SDOT then uses the energy simulation output to inform the designer(s) to a “*hybrid design alternative*”. Whilst this process claims to overcome “*unstructured individual or group decision-making*”, it could inform design decisions further if it identified specific measures which have the largest impact on for example the energy consumption.

### 2.2.2 LEED

The first version of the LEED rating system was published in 2000 by the United States Green Building Council (USGBC), and it was aimed at ‘*New Construction*’. Since then 8 more rating systems have been released, with applications ranging from ‘*Homes*’ to ‘*Healthcare*’. As part of the LEED International Roundtable, around 30 countries currently advise the USGBC on the development of the system. BREEAM and LEED have also been used to develop the Green Star rating system in Australia. This has been used to certify 587 projects, of which 140 have been certified in the last year (GBCA 2013).

Similarly to BREEAM, the scheme ‘*LEED New Construction and Major Renovations*’ awards points in several areas: ‘*sustainable site*’ (26), ‘*water efficiency*’ (10), ‘*energy and atmosphere*’ (35), ‘*materials and resources*’ (14), ‘*indoor environmental quality*’ (IEQ) (15), ‘*innovation in design*’ (6) (USGBC 2013a). The largest amounts of points available are in ‘*energy and atmosphere*’ (EA). Consequently it is one of the most important areas. Its subsection ‘*EA Credit 1: Optimise Energy Performance*’ in EA can award up to 19 points. In order to achieve these, a whole building simulation has to be performed or a prescriptive compliance path has to be followed. In the whole building simulation, the proposed building is compared to a baseline building. This process differs to BREEAM, as the performance metric is energy cost savings. This can be viewed as a limitation of LEED, as a building rating can be affected by the exchange rate of for example the US dollar (Inbuilt 2010). After all the points for various credits have been summed up, the building can be labelled as either ‘*Certified*’ (40-49 points), ‘*Silver*’ (50-59 points), ‘*Gold*’ (60-79 points) and ‘*Platinum*’

(>=80 points). As for the assessment process, the project team has to compile the evidence for the assessment. They then submit it to USGBC who review it and calculate the score. No trained assessor is required, although if a member of the design team is an LEED Accredited Professional an extra credit can be attained. Overall, accredited buildings will have a better energy performance than the standard building stock, and their economic value may also increase (Schwartz and Raslan 2013).

### **Tools for LEED accreditation**

In order for a tool to be able to be used to certify the EA credit, it has to adhere to the ASHRAE Standard 90.1-2007 appendix G (known as Performance Rating Method) (USGBC 2013a). Tools which are compliant to this, or can be used to gain LEED credits are listed below:

- The IES<VE> tool. One of its modules '*VE-Navigator for ASHRAE 90.1 (LEED Energy)*' automates credit assessment. This module is also used by IES TaP, which claims to streamline, manage and automate the certification process for LEED.
- Green Building Studio. It can be used for the following credits: Daylighting 8.1 Credit, Water Efficiency Credits 1, 2 and 3, Energy and Atmosphere Credits 1 and 2. It can however only be used as guidance. It cannot be used as a compliance tool, and does not generate the necessary documentation. It is targeted to be used early in the design process (Autodesk, Inc. 2013a).
- DesignBuilder. The interface to EnergyPlus can be used for the assessment of '*IEQ Credit 8.1: Daylight and Views—Daylight assessment*' (DOE 2013). EnergyPlus is compliant with ASHRAE Standard 90.1, so it can be used to attain Energy and Atmosphere Credit 1. The newest version of DesignBuilder '*v3*' claims that this has '*more ASHRAE 90.1 and LEED options*' (DesignBuilder Software Ltd 2005).
- AECOsim Energy Simulator. This performs the energy analysis necessary and is ASHRAE 90.1 compliant (Bentley Systems, Inc. 2013). It can be used alongside the AECOsim Compliance Manager. This tool automates the LEED compliance process.
- EcoDesigner Star. This claims it can be used to gain credits for the LEED rating systems (Graphisoft 2013a).

- Ecotect. It can be used to gain the credits: '*IEQc8.1: Daylight and Views – Daylight Requirements*' and '*IEQc8.1: Daylight and Views – Daylight Documentation*' (Skripac 2011).

### 2.2.3 BEAM PLUS

Hong Kong Building Environmental Assessment Method (BEAM Plus, formerly known as HK-BEAM) was first released in 1996 by the Real Estate Developers Association of Hong Kong. It was released as two schemes; one was addressing new buildings (HK-BEAM 1/96), and the other existing office buildings (HK-BEAM 2/96). It originates from the private sector (Ma and Wang 2009), but it is now owned by the HK-BEAM Society, which is run by volunteers. The latest version was released in 2013. BEAM Plus is aimed at all types of buildings, and calculates the energy consumption of a building. The assessment is split up into the following areas: '*Site Aspects*', '*Material Aspects*', '*Energy Use*', '*Water Use*', '*Indoor Environmental Quality*' and '*Innovations and Additions*'. Credits are gained in each area, and multiplied by a weighting factor. The weighting system is based on existing schemes, surveys and the opinions of the developers. The percentage of credits gained is used to award the following labels: '*Platinum*' (75%), '*Gold*' (65%), '*Silver*' (55%) and '*Bronze*' (40%). In order to qualify for an award, there are some minimum percentage of credits that have to be achieved for '*Site Aspects*', '*Energy Use*', '*Indoor Environmental Quality*' and '*Innovations and Additions*'. The significance of this rating system is that it claims by: "*May 2012...On a per capita basis, BEAM has assessed more buildings and more square meters of space than any other similar scheme in use worldwide*" (BEAM Society 2012 p.4).

#### **Tools for BEAM Plus accreditation**

The BEAM Plus assessment process includes four main stages: registration, submission & preliminary technical screening, assessment and certification. Then assessment stage is mostly undertaken by a BEAM Assessor. Energy assessment tools which are suitable for Beam Plus are listed in Appendix II of the Electrical & Mechanical Services Department (EMSD) Performance-based Building Energy Code 2007 Edition (EMSD 2007). However, tools which comply with Appendix G2 of Appendix G Performance Rating Method (PRM) in the standard ASHRAE 90.1-2007 (ASHRAE 2009b) can also be used. Examples of tools which can be used are given in Table 2.1; this collection of tools is not expected to be exhaustive.

**Table 2.1 Examples of tools which can be used for the BEAM Plus energy modelling (EMSD 2007 p.23; ASHRAE 2009b p.4)**

Simulation Method	Detailed Programs	Proprietary programs	Simplified Programs
ASHRAE 90.1-2007	EnergyPlus, DOE-2, BLAST		
EMSD Performance-based Building Energy Code 2007	DOE-2, EnergyPlus, Environmental System Performance (research) (ESP-r), TRYNSIS (Transient Systems Simulation), Building Load Analysis and System Thermodynamics (BLAST)	Carrier Hourly Analysis Program, Environmental System Performance (research) (TRACE 700)	e-QUEST Energy-10 ENER-WIN

#### 2.2.4 CASBEE

The Comprehensive Assessment System for Built Environment Efficiency (CASBEE) rating system (JaGBC 2013) originates from Japan, and was first released in 2004. It was developed by the International Initiative for a Sustainable Built Environment, as a spreadsheet tool, namely GBTool. As a result, it is quite different to BREEAM, LEED and Green Star. CASBEE is composed of four main assessment tools, as well as a collection of tools for special cases. Each main tool is intended to be used at different stages of a buildings lifecycle. Herein CASBEE for New Construction will be described in more detail. This is a self-assessment system which allows architects and engineers to be able to ameliorate the performance of their designs. If a third party assesses the building, it can be given a label. The assessment method is divided into four areas: *'Energy Efficiency'*, *'Resource efficiency'*, *'Local environment'* and *'Indoor Environment'*. The sub categories in these areas are split into two main groups: built environment quality (Q) and built environment load (L). In order to work out a label, the scores are worked out for all the subcategories of Q and L, and weighting system is applied. The final labelling depends on the Built Environment Efficiency (BEE), which is calculated as  $Q/L$ . Its total is used to determine what class the building falls in: C ( $0 \leq BEE < 0.5$ ), B<sup>-</sup> ( $0.5 \leq BEE < 1$ ), B<sup>+</sup> ( $1 \leq BEE < 1.49$ ), A ( $1.5 \leq BEE < 3$ ), S ( $BEE > 3, Q \geq 50$ ), where class

C is poor and class S is excellent. More information about the assessment method can be found in Saunders (2008)

### Tools for CASBEE accreditation

The CASBEE accreditation is performed using the CASBEE assessment software. This comprises of a spreadsheet, which has a score sheet and a results sheet. The CASBEE tools are all aimed at a different part of a buildings lifecycle, or for specific cases. The four basic tools aimed at different stages of a buildings lifecycle are in Table 2.2.

**Table 2.2 CASBEE assessment tools and when they are used in the building lifecycle (JaGBC 2013)**

Assessment tool name	Building lifecycle stage
CASBEE for Pre-design	Pre-design (planning stage)
CASBEE for New Construction	Design Stage
CASBEE for Existing Building	Post-design (Operation) stage
CASBEE for Renovation	Post-design (Renovation) stage

There is a large range of software targeted at special cases. The tools which have been translated into English to date are:

- CASBEE for New Construction (2012 edition).
- CASBEE for Home (Detached House) (2007 edition).
- CASBEE for Urban Development (2007 edition).
- CASBEE for an Urban Area + Buildings (2007 edition).
- CASBEE for Cities (2012 edition).
- CASBEE for Market Promotion (tentative version).
- CASBEE Property Appraisal (2009 edition).

### 2.3 ENERGY EFFICIENCY STANDARDS

In an attempt to mitigate climate change, the Department for Communities and Local Government (DCLG) has set a target that all new homes should be net zero carbon from 2016 (Communities and Local Government 2006). The European Parliament shares the view that greenhouse gas emissions must be reduced, and



recommended Passivhaus as a solution: *'[The European Parliament] Calls on the Commission to propose a binding requirement that all new buildings needing to be heated and/or cooled be constructed to passive house or equivalent non-residential standards from 2011 onwards, and a requirement to use passive heating and cooling solutions from 2008'* (European Commission 2008) as part of their resolution of 31<sup>st</sup> January 2008 on the document *'Action Plan for the Energy Efficiency: Realising the Potential'*. The view that Passivhaus could be implemented as a template to deliver significantly increased levels of energy efficiency is also shared by McLeod et al. (2012b). The paper argues that the Passivhaus Standard could be used by the UK to meet its greenhouse gas reduction targets, and converge upon a harmonised European standard for zero carbon buildings. It identifies the building envelope as a key element, as it can last up to 5 times longer than appliances and Low and Zero Carbon Technologies (LZCT).

An overview of the Passivhaus standard will be given below, including some of the design principles. This will be followed by a brief overview of MINERGIE, as part of this standard has adopted some of the Passivhaus design concepts.

### 2.3.1 THE PASSIVHAUS STANDARD

The Passivhaus (sometimes called Passive House in English) (iPHA 2012a) concept was first developed by Professors Bo Adamson from Sweden and Wolfgang Feist from Germany. Passivhaus is not just an energy performance standard, but a concept that attempts to balance high thermal comfort and low overall cost. The exact definition of a Passivhaus is: *'a building, for which thermal comfort (ISO 7730) can be achieved solely by post-heating or post-cooling of the fresh air mass, which is required to achieve sufficient indoor air quality conditions (DIN 1956)– without the need for additional recirculation of air'* (Feist 2006 p.1). These buildings have an energy demand so low that a conventional boiler is unnecessary. Buildings designed to the Passivhaus standard must have a well-designed envelope, using measures such as being airtight, well insulated, and having high specification windows. The buildings also utilise internal heat sources, the sun and heat recovery. Buildings designed to this standard have been shown to consume 90% less energy compared to an average house in Central Europe (iPHA 2012a). As a result, Passivhaus buildings could be used as a solution to fuel poverty (BRE 2011). This is important for the UK, as fuel poverty has been linked to causing extra deaths during the winter in Europe (Healy 2003). It is key to note that there is also a Passivhaus standard for existing buildings called EnerPhit (Quality-Approved Energy Retrofit with Passivhaus

Components). This recognises that it is difficult to renovate a building to achieve the Passivhaus standard, and therefore it has relaxed the Passivhaus requirements.

The concept has been applied worldwide: there are Passivhaus buildings in every European country, in places such as Australia, China, Japan and South America. There is even a research station built to the standard in Antarctica. The ten countries that have the most certified Passivhaus buildings are listed in Table 2.3. It is a fast growing standard, which is being applied to a range of buildings, both in terms of size and function. An example of a large scale development is the Bahnstadt project in Germany (EGH 2012). The land which originally hosted railway premises is being turned into the largest Passivhaus estate in Europe. The 116 hectares will provide accommodation for around 5000 occupants, and equally provide approximately 7000 workplaces.

**Table 2.3 The top ten countries for Passivhaus certified buildings, data taken from (iPHA 2013b)**

<b>Country</b>	Germany	Austria	Great Britain	Denmark	Ireland
<b>Quantity</b>	3720	685	271	182	145
<b>Country</b>	Sweden	France	Italy	China	Switzerland
<b>Quantity</b>	63	50	21	21	20

Unlike rating systems, for a Passivhaus to be certified it must adhere to specific criteria. A Passivhaus can be certified if either its annual heating demand is less than 15 kWh/(m<sup>2</sup>a) or if the peak heating load is less than 10 W/m<sup>2</sup> of living space. More information on the derivation of the peak heating figure can be found in Feist (2006). In addition, the buildings specific primary energy demand may not exceed 120 kWh/(m<sup>2</sup>a). This includes the energy used for hot water and all domestic appliances. The design of a Passivhaus can be made simpler by using certified components such as the building elements or the ventilation system (iPHA 2013a), although their use is not mandatory. This relatively high design specification has been identified as a barrier to Passivhaus adoption in the past. In a Zero Carbon Hub consultation (Zero Carbon Hub 2009 p.39) 47% of the attendees had a concern with the buildability of Passivhaus buildings at a mass scale. The high airtightness and presence of a ventilation system also raised questions with regards to occupant health. McLeod et al. (2012b) argues that there are many post occupancy studies which show the quality of air is acceptable. The results of the CEPHEUS project are in agreement with this (Schnieders and Hermelink 2006). In this project, 221

housing units in 5 European countries were built and monitored. The occupant's opinions on living in Passivhaus buildings were also recorded. A high level of satisfaction was found with factors such as comfort, well-being and the ventilation system.

### **Tool for Passivhaus certification**

The Passivhaus Planning Package (PHPP) is a steady-state tool, and its energy calculations are based on the international standard EN13790. Furthermore, it can be used for other applications, such as the ventilation system design, sizing of the domestic hot water system, window specification design and the forecasting of summer comfort (Feist 2007b). As a result, the tool can be used throughout the design process. One of the requirements of a Passivhaus is that it has to be airtight. A blower door test is used to determine the air changes per hour (ACH), when the difference in pressure between inside and outside is 50 Pascals. This value of ACH then has to be entered into PHPP before the building can be certified.

The certification of a Passivhaus involves both a Certified European Passive House Designer (CEPH), and a Building Certifier. Both have to be accredited by the Passive House Institute. The certification of a Passivhaus can only be performed by one tool, namely the Passive House Planning Package (PHPP).

PHPP simulation results have been validated against measured data from completed projects and the dynamic simulation tool DYNBIL, and have been found to show a good correlation (Feist 2007b). The main aim of PHPP was initially to replace the use of data intensive dynamic tools, whilst still giving reliable results ((Feist 1994) cited by (Feist 2007b)). It was developed by identifying key input from a range of simulation tools, and then determining a simplified model of which the details can be found in (Passive House Institute 1998) cited by (Feist 2007b).

Some of the main simplifications are:

- The whole building is treated as a single thermal zone;
- Calculations are in monthly or annual time steps.

It has however been argued that PHPP is still too time consuming to be used at the feasibility (conceptual) design stage (Bothwell et al. 2011), especially when alternative adaptations to buildings are being considered. As the tool is a spreadsheet which does not provide a visual representation of the building, there is a high risk of human error when data is being entered. The tool can use a range of

climate files, which are either defined within the software or can be custom defined. However, the time-step of the data is either monthly or a yearly average. The results from the calculation of certain boundary conditions such as shading factors and the TFA can also differ between Passivhaus Certifiers.

### 2.3.2 MINERGIE

MINERGIE originates from Switzerland (MINERGIE 2013), and can be used to label buildings, products and services. It markets itself as a '*brand*', and a '*successful business model*'. In order to certify buildings, there are three standards available: the regular '*MINERGIE-Standard*', '*MINERGIE-P-Standard*' and '*MINERGIE-ECO-Standard*' (OeJ 2010). The regular standard is mainly concerned with maintaining the comfort of occupants. This is achieved by buildings having a high quality envelope and using a ventilation system. The '*MINERGIE-P-Standard*' is said to correspond to the Passivhaus standard, and demands buildings have very low energy consumption. The '*MINERGIE-ECO-Standard*' adds ecological requirements to the first two standards, such as indoor air quality and noise protection.

The certification process partly relies on the energy performance being documented, and the final energy performance value (EPV) in kWh/m<sup>2</sup> per year is tested against a limiting value. MINERGIE acknowledges that there are 12 categories of buildings, and each has different limiting values and standard input data. The certification process also demands documents such as building plans, detailed drawings and notes on U-values, thermal bridges etc. The documentation is sent to MINERGIE, and they issue a provisional certificate. On completion of the building, the final certificate is issued. In order to maintain quality assurance, random site visits may be undertaken to the building sites.

#### **Tools for MINERGIE certification**

The certification of MINERGIE-P buildings relies on different tools. There are three main tools which are necessary for the energy calculation:

- The first tool calculates the '*heating energy*'. It must be compliant with SIA-Standard 380/1-2009, which is based on the EN ISO 13790 (OeJ 2010). There is a wide range of tools which conform with this, some of which can be found on the Kanton Zurich website (Kanton Zurich 2013). An example tool is Lessosai (E4tech 2013). This is also one of the tools recommended to be used for the embodied energy and daylighting calculations required by '*ECO*' related MINERGIE standards. Other details which need to be calculated include the energy savings due to heat recovery.

- The second tool is a so-called ‘*Supporting*’ MINERGIE MsExcel spreadsheet. More specifically, the French version is ‘*Justificatif MINERGIE-P Version 2013*’. This spreadsheet includes weighting factors which adjust values such as the hot water and heating energy. It also calculates the electricity consumption of the ventilation system, and the total EPV. This is checked against limiting values set by MINERGIE for different building types.
- The third tool is used to apply for the certification and receive evaluation. It is an online tool called ‘*Platform MINERGIE*’, but it is still under development.

## 2.4 COMPARISONS OF SUSTAINABLE BUILDING RATING SYSTEMS AND STANDARDS

A range of studies compare LEED and BREEAM, which originate from both academia and industry (Inbuilt 2010; Schwartz and Raslan 2013; Saniuk 2011; Roderick et al. 2009; Bunz et al. 2006; Lee 2013). These often include other rating systems from around the world, whose use may not be as widespread.

According to a report by the consultancy Inbuilt LEED and BREEAM overlap in many areas (Inbuilt 2010 p.14). They also claim that a building which scores high in one rating system may not score as well in another. They argue that the reason is that BREEAM is more prescriptive, and relies on specific technologies or solutions being implemented. It could also be due to BREEAM having a better scientific basis behind some of the credits. The observation is supported by other studies (Lee and Burnett 2008; Saunders 2008). Lee and Burnett (2008) compared buildings assessed with the HK-BEAM, LEED and BREAM assessment methods. One of their main conclusions was in comparison to LEED and HK-BEAM, BREEAM is the most difficult assessment method under which to score energy credits. Saunders (2008) compares the rating systems: LEED, BREEAM, CASBEE and Green Star. For more information Green Star please refer to Saunders (2008). One of the main conclusions is that a high scoring building under the BREEAM assessment method will score well, but that buildings in other systems that have high scores may not score well in the BREEAM rating system. For example if a building is designed to comply with CASBEE or Green Star criteria, it is only likely to achieve a BREEAM rating of a ‘*Pass*’.

A study undertaken by Roderick et al. (2009) shows a slightly different trend. The BPS tool IES <VE> 5.9 was used to simulate an eight storey building, which contained open plan offices. Under the relevant energy sub section of LEED and

BREEAM, the building managed to achieve 0 out of 10 points and 2 out of 15 points respectively. The study also considers the Green Star rating system, which for the same building achieves 11 out of 20 points. This high rating is partly attributed to (a) the different calculation methodology, and (b) the heating, ventilation, and air-conditioning being responsible for 65% of the total energy consumption in the Green Star rating system. The former does not agree with the study by Lee and Burnett (2008), as they concluded that the difference in assessment methods does not affect assessment results. The study relied on earlier versions of the assessment methodologies, so it is possible that there is more of a difference between the new versions.

Another study focused on the effect of using different BPS tools on achieving credits in BREEAM and LEED (Schwartz and Raslan 2013). Their conclusions include that the performance of a building simulated in different tools can differ up to 35%. This did not affect the amount of points that can be awarded under the two rating systems, as they are awarded based on a difference between baseline/notional buildings and proposed buildings. This is also supported by the study undertaken by Lee and Burnett (2008). They came to the conclusion that assessment results are not affected by the use of different simulation tools. However, they also concluded that the difference in energy use assessment methods also does not affect assessment results. This has been argued in the past as not valid. Saunders (2008) contended that if rating systems are used outside of their native country, they need to be tailored to take into account the local context. For example, CASBEE was found hard to compare to the other schemes, as more than half of the criteria are associated with designing for the possibility of earthquakes and typhoons. In addition, BEAM Plus assesses peak electricity demand, in an attempt to delay the expansion of electricity generation and distribution (Lee 2013). Ozone depleting substances are banned in most countries, but not in the US. Therefore, the LEED system must cover this issue, but it may not be applicable in other countries. Examples can also be found in rating systems used around the world other than those outlined in the previous sections 2.2.1 to 2.3.2. In a review by Saniuk (2011) the rating system Estidama, which is tailored for the Middle East, places importance on water conservation. In another paper (Lee 2013), the voluntary scheme '*Evaluation Standard for Green Building*' developed by China is identified placing importance on peak electricity demand. This is due to power shortages being a real danger in China.

The Passivhaus standard cannot be easily compared to rating systems, as the criteria for and process of certification is very different. However, some sources have made general comparisons. An article in the Architects Journal claims that Passivhaus can deliver more energy efficient buildings than BREEAM and LEED (Tunnickliffe 2012). This is supported by the fact that a Passivhaus building has been shown to use up to 90% less energy, and:

- a) A building built to 'LEED for Homes' will use only 20-30% less energy (with some buildings achieving up to 60%) than a building built to building regulations (USGBC 2013b).
- b) BREEAM 'Outstanding' and 'Excellent' buildings will use 40% and 25% less energy respectively than if it was built to building regulations (Bevan 2011).

Similarly to the BREEAM scoring comparison issue with other rating systems, another observation has been made that whilst a building may lend itself to Passivhaus, it may not achieve good CSH ratings, and vice versa. In a study undertaken by Parker (2009), a conclusion was reached that a Passivhaus dwelling's energy savings are not "*realistically represented*" by its CSH ratings. The case study used is a Passivhaus building in Denby Dale, which was shown to only achieve a level 3 in CSH. Conversely, the Kingspan Lighthouse building has a CSH level 6 as it uses many renewable technologies, but it would not pass as a Passivhaus due to its high heating demand and lack of airtightness. One conclusion from the study is that to achieve a high level in CSH, renewable technologies are more important than improving the building fabric. This attitude is detrimental to lowering future emissions, as the building fabric lasts longer than renewable technologies. In the construction industry, one reaction to the findings in this study is: "*While we applaud the general approach of CSH in getting the construction industry to think about sustainability issues, we believe that it urgently needs to be revised to accommodate Passivhaus approaches more accurately*" (Green Building Store 2009).

Several comparisons can also be made between Passivhaus and MINERGIE standards. Some of the figures used as limits for Passivhaus, MINERGIE and MINERGIE-P are presented in Table 2.4. The minimum U-values between Passivhaus and the regular MINERGIE standard are very similar, with the main difference being that Passivhaus demands lower door and window U-values. In contrast, the MINERGIE standard requires a higher heat recovery efficiency value.

In terms of the heat and energy demand values, there is quite a difference between terminology and what they represent.

Passivhaus has set limits for a primary energy demand, heating load and heat demand. The primary energy demand calculation includes the space heating, domestic hot water, lighting, fans and pumps and also all of the projected appliance consumption. The heat load is a peak demand for the heating of air which must not be exceeded at any point. The heat demand is the total space heating required over the period of a year. In order to certify a Passivhaus, either the heat load or heat demand has to be met.

In the MINERGIE standard, the EPV, heating load and heating demand is limited. The MINERGIE EPV includes the space heating, hot water, and ventilation energy use. The MINERGIE-P EPV figure includes space heating, cooling, hot water, ventilation and auxiliary energy use. For the MINERGIE standards, the heating demand must be a certain percentage lower than Swiss Building Regulations (SIA380/1:2009). Alternatively, for the MINERGIE-P certification it can be limited instead by 15 kWh/m<sup>2</sup>, which is the same value used by the Passivhaus standard. The Passivhaus limits are the same for every building type, whilst the MINERGIE limits tend to differ. For example, the regular MINERGIE limit ranges for a new construction between 20-70 kWh/m<sup>2</sup>, and an individual house has the limit 38 kWh/m<sup>2</sup>. The MINERGIE-P standard shares more design parameters with Passivhaus than MINERGIE, such as the heating load, needing to limit thermal bridges and have airtight buildings. This is due to MINERGIE-P being an adaptation of the Passivhaus standard.



**Table 2.4 A comparison between the Passivhaus, MINERGIE and MINERGIE-P standards. EPV values are only given for two building types.**

Design parameters	Standards		
Building Element U Values	Passivhaus <sup>1</sup>	MINERGIE <sup>2</sup>	MINERGIE-P <sup>3</sup>
Wall	$\leq 0.15 \text{ W/m}^2\text{K}$	$\leq 0.15 \text{ W/m}^2\text{K}$	$\leq 0.15 \text{ W/m}^2\text{K}$
Roof	$\leq 0.15 \text{ W/m}^2\text{K}$	$\leq 0.15 \text{ W/m}^2\text{K}$	$\leq 0.1 \text{ W/m}^2\text{K}$
Floor	$\leq 0.15 \text{ W/m}^2\text{K}$	$\leq 0.15 \text{ W/m}^2\text{K}$	$\leq 0.1 \text{ W/m}^2\text{K}$
Windows	$\leq 0.8 \text{ W/m}^2\text{K}$	$\leq 1.0 \text{ W/m}^2\text{K}$	$\leq 0.8 \text{ W/m}^2\text{K}$
Doors	$\leq 0.8 \text{ W/m}^2\text{K}$	$\leq 1.2 \text{ W/m}^2\text{K}$	$\leq 0.15 \text{ W/m}^2\text{K}$
Heat recovery efficiency	$\geq 75\%$	$\geq 80\%$	$\geq 80\%$
Primary Energy Demand (Passivhaus) / EPV (MINERGIE)	$< 120 \text{ kWh/m}^2$ per year	Dwelling: $\leq 38 \text{ kWh/m}^2$ ; Commercial: $\leq 40 \text{ kWh/m}^2$	Dwelling: $\leq 30 \text{ kWh/m}^2$ ; Commercial: $\leq 25 \text{ kWh/m}^2$
Heating load	$< 10 \text{ W/m}^2$	-	$< 10 \text{ W/m}^2$
Heat(ing) demand	$< 15 \text{ kWh/m}^2$ per year	$< 90\%$ of $Q_{h,li}$ based on SIA380/1:2009	$< 60\%$ of $Q_{h,li}$ based on SIA380/1:2009, <b>or</b> $< 15 \text{ kWh/m}^2$ per year
Thermal bridges	Minimise	-	Minimise
Air changes	0.6/h	-	0.6/h
Airtightness	High	-	High

Notes: <sup>1</sup>(Feist et al. 2007), <sup>2</sup> (OeJ 2010), <sup>3</sup> (FaJ 2012)

## 2.5 CONCLUSIONS

This chapter outlines and compares the state of the art in sustainable building rating systems and standards, and the tools they rely on for energy analysis. The main conclusions drawn are:

- BREEAM and LEED are widely used, and have been used to develop other schemas worldwide. Hence, there are some similarities between the assessment credits. Beam Plus is also intensively used, and claims to have certified the most buildings on a per capita basis. CASBEE was developed independently from the other schemes and is quite different as a result. All

the systems use some degree of weighting system. The assessment processes tend to differ as well. Some rely on a specialist using analysis tools whilst others are aimed the building designers. (Section 2.2). *The use of rating systems is not limited to their country of origin. However in some cases, they have to be adapted to take into consideration local regulations, opinions etc. Tools which are aimed at building designers offer an opportunity to ameliorate the performance of a building, and not simply receive a rating.*

- There are a range of analysis tools which support the BREEAM, LEED, CASBEE, Beam Plus and MINERGIE. The degree to which the tools can be used ranges from being able to use it as a guide to fully automating the certification process. Most of them are also not limited to a single rating system. For example, IES<VE> and EcoDesigner Star (Beta test stage tool) are aimed at both BREEAM and LEED. (Section 2.2 and 2.3). *Tools enabling certification should intend to be versatile, and not just serve a single purpose. This gives them a chance to be used by a wider community. New tools are still being introduced which simplify the accreditation process.*
- Whilst the MINERGIE-P standard is said to correspond to the Passivhaus standard, the certification process is very different. Most significantly, there is only one tool which can be used in the Passivhaus certification process: PHPP. The MINERGIE brand in general seems more business oriented, and is actively targeting specific markets. It is also updating the way that certification currently works, integrating databases and the certification/evaluation process to be all done centrally online. There are also more types of the MINERGIE standard, focused on achieving different aims. (Section 2.3) *The Passivhaus design concept is successful, and there is a market for low energy buildings. It could be argued that the certification process could be updated.*
- There are many conflicting observations when rating systems are compared. BREEAM appears to be the most stringent rating system. However, the Passivhaus standard was identified as being able to deliver the largest reduction in energy demand. Another observation is that even though the MINERGIE-P standard is based on the Passivhaus standard, several differences exist between them. There are also quite a few differences in the terminology used to describe performance. (Section 2.4) *The use of rating*

*systems and standards is still an active research field. It is possible that the energy simulation field could benefit from the standardisation of some of its terminology. This would enable the comparisons between standards to be clearer, which could benefit potential clients when they are choosing between them.*

## Chapter 3 REVIEW OF BIM

This chapter begins by defining BIM (Section 3.1). It continues with a description of its global adoption (Section 3.2). Some of the main benefits and limitations of BIM implementation are then discussed (Section 3.3). As part of the BIM adoption process includes companies having to implement new software tools, a brief description of some of the BIM software available is given, and comments are made on their strengths and weaknesses (Section 3.4).

### 3.1 INTRODUCTION

The BIM concept has been documented since 1975, when it was called a '*Building Description System*' (Eastman 1975). The current term BIM was first used by AutoCAD (Bazjanac 2004), and was later made popular by industry analyst Jerry Laiserin (Smith and Tardif 2009). BIM has many definitions, but most agree that primarily it is a process (Eastman et al. 2011; NIBS 2007; Azhar et al. 2008; bSI 2013). The definitions vary in complexity, for example Bazjanac (2004) claims BIM is simply "*the act of creating a Building Information Model*", whilst Eastman et al. (2011) presents it as "*a modelling technology and associated processes to produce, communicate and analyse building models*". It is interesting to note that it has been used synonymously with the term Virtual Design and Construction (VDC) (Khanzode et al. 2008). VDC and BIM are both described in this paper as "*the use of parametric CAD [Computer Aided Design] models for analysis of various design, and construction problems*". It has also been noted that in India, BIM is often referred to as VDC (Nispana 2013). The non-profit organisation buildingSMART International (bSI) (formerly the International Alliance for Interoperability) supports the use of BIM worldwide (bSI 2013). Their definition of BIM is: "*a BUSINESS PROCESS for generating and leveraging building data to design, construct and operate the building during its lifecycle. BIM allows all stakeholders to have access to the same information at the same time through interoperability between technology platforms*". Throughout this thesis, BIM will correspond to this definition.

### 3.2 WORLDWIDE BIM ADOPTION

BIM adoption has been occurring worldwide over the past few decades. For example, bSI now has regional chapters in Europe, North America, Australia, Asia and the Middle East. New chapters are still being created, for example the Hong Kong chapter was inaugurated in 2013. Internationally, adoption is also encouraged by many governments. In 2008, the following countries signed a '*Statement of intent to support Building Information Modeling with Open Standards*': US, Norway,

Finland, Denmark and the Netherlands. Since then, the use of BIM is required in these countries by various sources. In the United States, the General Services Administration (GSA) requires at a minimum a spatial program BIM, and encourages more mature implementations. The GSA has also developed BIM guidelines, and encourages the use of BIM in the public sector. The Norwegian Directorate of Public Construction and property (Statsbygg) demands its use on all its buildings. The state property services agency Senate Properties in Finland has similarly requested BIM use in all of its projects. Various state clients are requesting BIM in Denmark. In the Netherlands, the Government Buildings Agency mandates BIM, which is supported by the Rgd BIMnorm standard. This standard was produced by the agency Rijksgebouwendienst. In addition, Hong Kong's Housing authority has the target of using BIM in all its projects by 2014. South Korea's Public Procurement Service also has a target BIM use. It aims to use BIM on all public projects, and all projects over \$50 million by 2016. In the UK, the government requires a certain level of BIM implemented by 2016 on its projects (Cabinet Office 2011). The different levels of BIM maturity are explained further down in this section.

In addition, the world's first BIM electronic submission system was launched by Singapore by the Building and Construction Authority in 2008. The systems purpose is to streamline the process of regulatory submission, and relies on a single building model containing all the information necessary. The idea of a single building model is also shared in the BIM Overlay to the RIBA Plan of Work (Sinclair 2012).

In the past, various surveys have been undertaken to assess the state of adoption of BIM in various countries (Kumar and Mukherjee 2009; NBS 2013; McGraw Hill Construction 2012). The percentage of industry accepting BIM varies significantly in the surveys. In India, a survey by Kumar at al. (2009) was undertaken on architectural, engineering and construction companies that showed that 47% of the participants are using or testing BIM. A survey was undertaken in North America which showed the adoption of BIM has risen from 49% in 2009 to 71% in 2012. Furthermore, the use of BIM has increased significantly over the last few years also in the UK construction industry. In a survey published by the National Building Specification (NBS) (NBS 2013):

- The percentage of industry using BIM rose from 13% in 2010 to 39% in 2012
- In 2012, 54% of industry is not using BIM but is aware of it, 77% of whom said that they would be using it in the next year.

In research, the process of BIM adoption has been described using a wide range of metrics. After surveying examples of BIM adoption in literature, Jung and Joo (2011) divide the application of BIM as either top-down and bottom-up. The top-down approach is where multi-dimensional integration is attempted. The bottom-up approach is where BIM is first adopted as a 3D visualisation tool and then multi-dimensional capabilities are adopted later. Jung and Joo (2011) observe that the top-down approach has been noted on multiple occasions as not economically feasible.

The bottom-up approach is further divided as being passive or active. The passive use is described as when BIM is used for visualisation or analysis, and the active use of for example by introducing automation into design. The bottom-up approach is also advocated by Arayici et al. (2011), who describe the adoption process of BIM in an architectural practice. They argue that the adoption of BIM relies equally on technology and people, and that the bottom-up approach results in benefits such as change in management's strategies and limiting resistance to change. They also conclude that the support of the top management is important for change to occur. People being a barrier to BIM adoption has also been identified in a study by RICS (RICS 2013). The study was undertaken at the RICS National BIM conference in London. It identified '*culture*' as the main problematic area with introducing BIM to the workplace. This area rated higher than issues such as '*training*', '*cost*' and '*legal*'. Another barrier acknowledged by 46% of the participants was a low demand for BIM from their clients.

Taylor and Bernstein (2009) suggest an entirely different way to describe BIM adoption, using four main paradigms. These paradigms were developed by qualitatively and quantitatively analysing 26 cases of BIM use in industry. In the first paradigm BIM is said to be adopted to enhance visual impact and to help develop a better understanding of the proposed building model. In the second paradigm BIM is used for the coordination of data over the project network. Some users advance to the third paradigm and experiment with changing building properties to affect performance, including: cost, thermal and lighting performance, ventilation, and evacuation in the event of a fire. The final paradigm that BIM adoption can evolve to is when it is enriched with supply chain information. In the study of Taylor and Bernstein (2009), nine companies out of the twenty-six were following this paradigm, so it is reasonable to assume that whilst this level of adoption can be achieved, the barriers to this level must be still significant.

There are many maturity levels of BIM, and the fully collaborative BIM refers to a 'Level 2' BIM (BIM Industry Working Group 2011). Figure 3.1 shows these different levels, and the progression from 2D CAD to a process which is fully open and reliant on web services for data integration. 'Level 0' describes a stage where 2D CAD is used, and data is exchanged using paper based methods. There is one main difference between the use of BIM and 2D CAD. 2D CAD describes a building with graphical entities (such as lines) which create independent 2D views (such as plans, sections and elevations). A BIM model however contains a range of information that is related to the building such as physical but also functional data (Azhar et al. 2008). 'Level 1' shows a stage where 2D or 3D CAD is used and some standards may be used for data exchange, but factors such as cost are still calculated without integration. 'Level 2' describes a stage where information is stored in BIM tools, and some integration is occurring through proprietary tools or interfaces. Aspects of multi-dimensional BIM such as cost and time may be applied to BIM models. This is the level that the Government has requested to be used on its projects by 2016. Finally, 'Level 3' describes a state where integration is seamless through IFC/IFD, and data is stored in central servers. The definitions are contradictory to a certain extent, as whilst 'Level 2' aims at full collaboration, proprietary files can still be used for data transfer. It can be argued technology such as IFC/IFD should be in 'Level 2'.

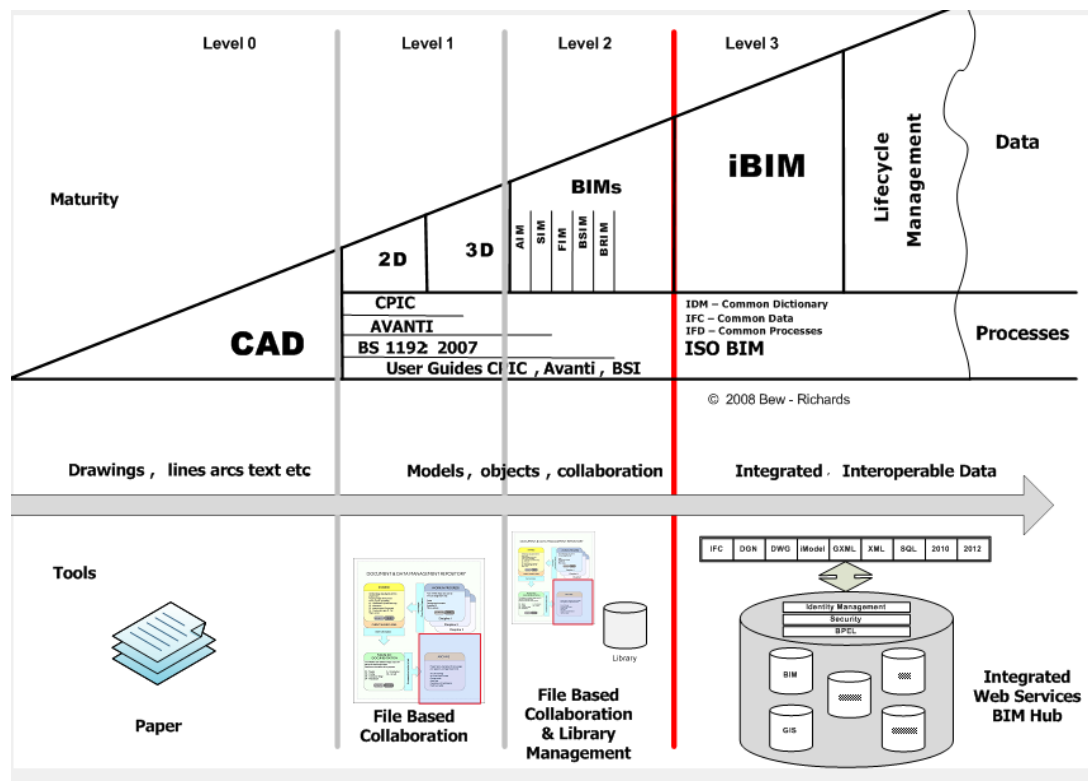
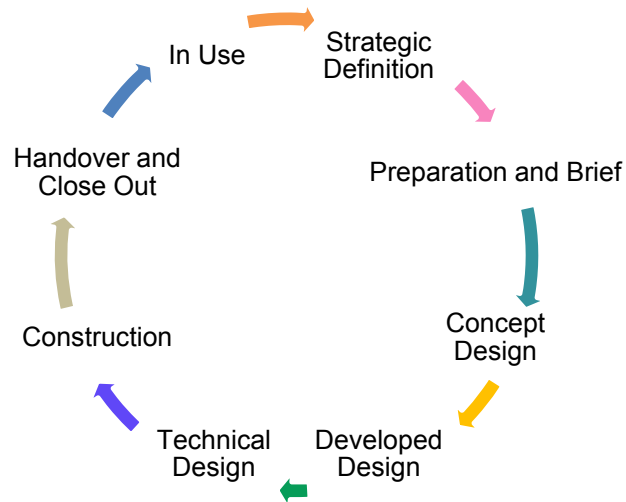


Figure 3.1 Different levels of maturity of BIM adoption (BIM Industry Working Group 2011)

BIM adoption is also supported by the recent RIBA Plan of Work 2013 (Sinclair 2013). An outline of the new tasks can be seen in Figure 3.2. The update which is relative to BIM is that the tasks to be performed under each stage now include “*UK Government information exchanges*”. It is not required in every project, but its purpose is to support the information exchanges demanded by the government.



**Figure 3.2 The RIBA Plan of Work 2013 stages, adapted from (Sinclair 2013).**

### 3.3 BENEFITS AND CHALLENGES

A key benefit of using a model that is created with BIM technology is the ability to represent the whole building lifecycle, including the construction, fabrication and procurement stages (Eastman et al. 2011). This leads to benefits in different stages of a buildings lifecycle (Forbes and Ahmed 2011; Eastman et al. 2011). Common themes are repeated in benefits published in literature, such as cost, time, quality and productivity. Examples of these can be found in Table 3.1.

BIM has also been said to promote collaboration (Singh et al. 2011; Isikdag and Underwood 2010), which will affect all of the above categories. Collaboration has been defined as involving “*the ability of the different participants to work on their part of the project using their own particular ways of working whilst being able to communicate with the other participants to bring about a common objective*” (Isikdag and Underwood 2010). Singh et al (2011) state that BIM servers can support multi-disciplinary collaboration, and they propose a framework which specifies features and technical requirements for a BIM server. It discusses for example the BIM model access and usability features, such as downloading and uploading files. One subject which is not addressed is the file format the data is shared in. As design and analysis tools can share data using different methods, the data format that a server accepts could be influential to the choice of server by potential server users.



**Table 3.1 Examples of the benefits of BIM**

<b>Category of Benefit</b>	<b>Example</b>
<b>Cost</b>	Controlled whole lifecycle costs (Forbes and Ahmed 2011)
	Decreased cost of projects (Azhar et al. 2008; Gilligan and Kunz 2007; BIM Industry Working Group 2011)
	Design changes are cheaper to undertake (BIM Industry Working Group 2011)
	Project cost is close to budget, due to reduced error (Gilligan and Kunz 2007)
	High returns on investment (Azhar et al. 2008; McGraw Hill Construction 2012)
<b>Time</b>	Clash detection in a model can identify potential problems which would otherwise be identified later and potentially cause delays (Azhar et al. 2008)
	The use of BIM enables rapid decision making in the early design process (Gilligan and Kunz 2007)
	Time taken to generate a cost estimate is reduced (Gilligan and Kunz 2007)
	Faster delivery speed (Forbes and Ahmed 2011);
	Processes are faster and more effective (CRC Construction Innovation 2007)
	An overall cost saving can be experienced in a project, as for example rework and conflicts in installations are limited and parts of the construction can be more easily prefabricated (Khanzode et al. 2008)
Design changes can be tested faster (BIM Industry Working Group 2011).	
<b>Quality</b>	Better design, customer service and production quality (CRC Construction Innovation 2007)
	Improved value in the construction handed over to the client and better performing buildings (BIM Industry Working Group 2011)
	Cost estimation accuracy increased (Gilligan and Kunz 2007)
<b>Productivity</b>	Increases labour productivity (Kaner et al. 2008; Gilligan and Kunz 2007; Forbes and Ahmed 2011);

Another study claims that BIM can benefit Project Managers (Bryde et al. 2013). They supported this statement by analysing the common benefits of BIM in 35 publically accessible case studies. The case studies were scored using specific criteria, and a point being awarded or taken away depended on the criterion being mentioned in a positive or negative way. The criteria, sorted by the most often occurring as a positive benefit to last, are as follows: cost reduction or control, time reduction or control, communication improvement, coordination improvement, quality increase or control, negative risk reduction, scope clarification, organization improvement, software issues (Bryde et al. 2013). The shortcoming of this study is that each mention of a positive or negative benefit is equal in weight. If a criterion was mentioned in both ways and yet the positive benefit was much larger, the two cancel each other out and no points are awarded.

Before BIM can be fully adopted, there are various limitations that need to be addressed regarding the technology associated with BIM (Cerovsek 2011; Azhar et al. 2008; Bryde et al. 2013; Steel et al. 2012; McGraw Hill Construction 2012). Cerovsek (2011) argues that a key issue in the Architecture, Engineering, Construction and Operations (AEC/O) industry is interoperability, especially between multiple models and tools. One of the main conclusions of the paper is that BIM schemas should be constantly improved, where an external schema is described as enabling data transfer between different tools and being built to show different views of a building. The IFC are given as an example of an external BIM schema. The viewpoint on interoperability being a key issue is in agreement with the study by Bryde et al. (2013) and a survey on North America (McGraw Hill Construction 2012). Bryde et al. (2013) identified the most common limitation of BIM as software issues. One of their conclusions on this subject is that technical issues “*are likely to be resolved over time by the IT companies supplying the packages*” (Bryde et al. 2013). Whilst this is possible to a certain extent, the solutions will be mostly proprietary and BIM companies will never directly link their product to every existing analysis tool due to the sheer volume of tools available. One solution to this is having a standard data transfer model, so data will be automatically transferable between software which is compatible with the data transfer model. This viewpoint seems to be supported by (a) the government, as the IFC are solely named in Figure 3.1 for describing data, and (b) papers such as Steel et al. (2012), where BIM model interoperability is summarised from only the viewpoint of an IFC user.

Another significant current drawback is that many BIM tools appear to focus on the 3D graphical representation of a building, yet a BIM model should not just concern

itself with physical geometry (Smith and Tardif 2009). It should also be able to facilitate other processes such as analysing a buildings thermal performance. Howell and Batcheler (2005) have found that BIM is not flexible enough to be able to test alternative design approaches using '*what if*' scenarios. These scenarios are used for purposes such as optimising a buildings performance, or testing its fire safety. They observed that another problem is the sizes and complexities of files on complex projects can pose a problem. They additionally highlight the need for better interoperability between design and analysis tools. They argue that a project team will not want to adopt a single BIM system. They will want to use a range of software they trust, that may be from various different software companies.

Other limitations or challenges which are less technology oriented have been argued by (Eastman et al. 2011) as including:

- Legal issues, such as who owns what data, and who is responsible for its accuracy. The issue of liability and responsibility is also shared by Howell and Batcheler (2005).
- Changes in practice, such as the incorporation of construction knowledge into the design stages, as the same building model can be used for both the design and construction phase. This is supported by an observation from Howell and Batcheler (2005), who state that data management will have to become more sophisticated as multiple teams may try to access the same objects on central servers.
- The implementation process of BIM, as when a company decides to finally adopt BIM its whole business process will change. The use of a consultant is recommended, to advise on aspects from how to plan BIM adoption to the fact you should start on small projects.

### 3.4 EXISTING BIM AUTHORING TOOLS

BIM models are repositories of project information that have been populated using an authoring tool. BIM authoring tools use an object-based parametric modelling system where the objects are embedded with rules that help to determine their behaviour (Eastman et al. 2011). These rules allow low-level automatic design editing, which is particularly useful for complex building models. A resultant limitation is that the BIM tools are inherently complex to use. BIM authoring tools are part of model generation platforms, which will be used for different purposes and even by different domains. When different BIM tools and platforms are combined in an

organisation the overall system is called a BIM environment. The concept of tools, platforms and environments will become more important in the later stages of BIM adoption where more emphasis is on the integration. BIM should not be viewed as '*only one of many purpose-built models*' as in a paper by Howell and Batcheler (2005), but as a process in which many purpose built models share data.

Commonly used BIM authoring tools from leading providers of BIM solutions include Autodesk Revit, Graphisoft Archicad, Bentley Architecture, Digital Project and Vectorworks (Howell and Batcheler 2005; Eastman et al. 2011). The tools chosen are architecture centric, as the focus of this thesis is to support the transfer of data between building design and analysis tools. Autodesk Revit, available in Architecture and MEP (Mechanical, Electrical and Plumbing) versions, is a proprietary data model that stores information about objects in a central project database. If any object is altered in the database, the change is reflected across the project team's models. Eastman et al. (2011) have identified this BIM platform as the market leader, but also stated that it slows down significantly for larger projects. As a tool, it has been identified to have an easy-to-use interface. Bentley Architecture from Bentley Systems is part of a range of modules, which when used together form an integrated project model. Bentley strengths are the range of modules they offer, such as Bentley Rebar. It can easily support large projects, but this forms part of its weakness. A great part of the products are partially integrated through the user interface, and so there is a steep learning curve. ArchiCAD was possibly the first commercially available BIM tool (Ibrahim and Krawczyk 2003), and has a completely different view; it regards the BIM model as a virtual building model around which many applications (e.g. ArchiCAD) orbit. ArchiCAD can also be linked to other tools from different domains using either a direct link through the Geometric Description Language or through the Industry Foundation Classes (IFC). Examples include Revit Structure from the structural domain, Revit MEP from the mechanical domain and IES <VE> from the energy analysis domain. Its strengths include having an intuitive interface, having a large object library and a rich suite of supporting applications. It has however some limitations when applied to larger projects, and in the definition of custom parametric objects (Eastman et al. 2011).

Other BIM platforms used in the design of buildings include Digital Project and Vectorworks (Eastman et al. 2011), although the use of these tools is not limited to the construction industry. Digital Project is based on a parametric tool which is also used in the aerospace and automotive industry. It includes many sophisticated tools which lead to a range of benefits, but consequently there is a steep learning curve to

the system as a whole (Eastman et al. 2011). Vectorworks also supports other sectors, for example the marine industry. Its user interface incorporates a range of tools, which are linked to the main tool either directly or through the IFC. The BIM tools can perform a range of tasks, but Eastman et al. (2011) does not consider it as a BIM environment as objects do not store parametric information such as version and a globally unique identifier. Trimble Sketchup also models a building in 3D and attaches information to objects, and is regarded by some as a building product model and part of the BIM process (Cho et al. 2011). Nevertheless, it isn't based on parametric modelling and cannot be labelled as a real 'BIM tool' (Malin 2007), but it is widely used as it has a very simple interface. An in-depth analysis of these and other BIM systems as tools, platforms, and environments is given in (Eastman et al. 2011).

After BIM models have been populated, they can be used by 'downstream' applications. These applications generally have different internal architectures usually requiring data to be manipulated before being exchanged (Bazjanac and Kiviniemi 2007). The next section will focus more on the interoperability between BIM tools and energy analysis tools.

### 3.5 CONCLUSIONS

The focus of this chapter was the adoption of BIM, and how it influences design. The main conclusions on this subject are:

- The BIM process is replacing current practice worldwide, and in some cases this is driven by governments. There are many differences between current practice and BIM. A single BIM model can be used, which contains information that can be accessed by all the project stakeholders. Models can also be electronically submitted for compliance checking. In addition, there are several different levels of BIM maturity. This suggests that even once a level of BIM is implemented, more changes may have to be implemented. (Section 3.2) *Implementing BIM will require changes to current practices in the design and construction of buildings, but many countries show that the process is possible. In addition, forward thinking software developers should be developing tools which can be also used in the later stages of BIM adoption.*
- The implementation of BIM results in many benefits related to aspects such as time, cost and quality. BIM still faces some challenges. A range of

problems with interoperability need to be addressed. The paradigm of a single BIM model does not lend itself to testing alternative designs. This can affect the final energy efficiency of a building. A single model can also result in legal issues. (Section 3.3) *By not adopting BIM, companies are missing an opportunity to deliver better designed buildings at a lower cost. Nevertheless, before BIM can be fully relied upon to replace current practice and provide seamless interoperability, some issues still have to be addressed.*

- An overview of BIM software has been given, to give a holistic view of the BIM adoption process. BIM systems do not consist of just BIM authoring tools, but they can be regarded as platforms and environments. These systems tend to have different strengths, with some tending towards user friendliness and others addressing the definition of complex custom defined objects. The choice of tools has also been shown to depend on the client based on a history of use. The market leader has been put forward as Autodesk Revit. As a tool, it has an easy-to-use interface. (Section 3.4) *BIM tools are not limited to the 3D visualisation of buildings. They can form platforms and environments that share and reuse data. One limitation of some families of BIM tools is the sharing of data tends to be within a software vendor, and does not support general neutral data transfer. However, some software vendors do recognise the importance of neutral data transfer, such as ArchiCAD and Vectorworks.*

As interoperability has been labelled as a key issue with BIM in the AEC/O industry, and it directly affects the sustainable design of buildings, it will be the main limitation addressed in this thesis, and will be examined in more detail in the next section.

## Chapter 4 INTEROPERABILITY BETWEEN BIM AND ENERGY ANALYSIS TOOLS

The previous chapter reviewed the adoption of BIM. One of the problem areas of BIM was identified as interoperability with other tools. This chapter therefore focuses on interoperability. It begins with its definition (Section 4.1), and then presents an overview of data standardisation efforts (Section 4.2). An example of such an effort is the IFC schema (Section 4.2.2). This is followed by a description of data exchanges between BIM environments and different software vendors which support rating systems and standards (Section 4.3). As a result, conclusions are made on what specific issues need to be addressed (Section 4.4).

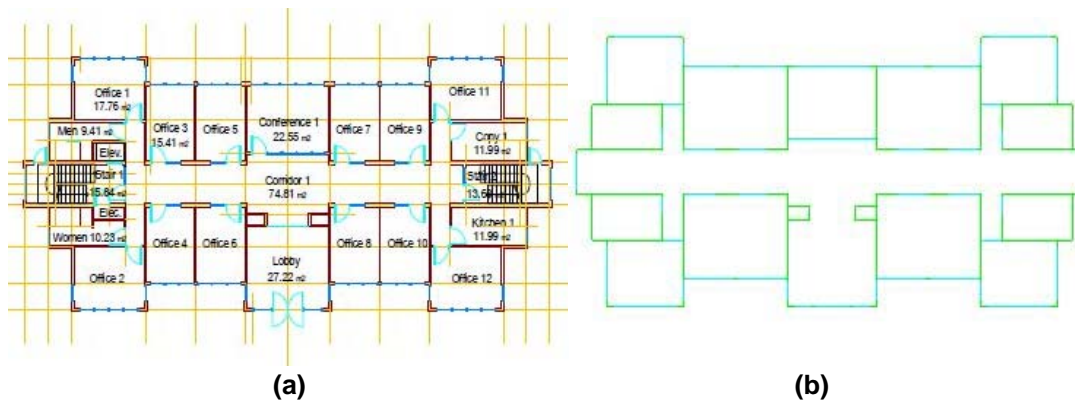
### 4.1 INTRODUCTION

During the design and construction of a building a range of tasks have to be undertaken using software tools such as BIM and BPS tools. Interoperability is “*the ability to pass data between applications, and for multiple applications to jointly contribute to the work at hand*” (Eastman et al. 2011 p.100). Interoperability should eliminate data repetition and inherent human error, and enable rapid iterations of a design. BIM platforms can transfer data to simulation tools such as energy analysis tools, by translating a BIM data model to a format needed by the analysis tool. In some cases, analysis tools can transfer data back, but usually the results are used simply to inform further design decisions. Data transfer between platforms and tools has been labelled as the “*fundamental form of interoperability*” (Eastman et al. 2011 p.101). Interoperability can occur either directly between the platforms and tools, or using a data transfer model such as IFC or the Green Building XML schema (gbXML). Other types of interoperability are tool-to-tool exchanges, for instance between different modules within a platform, and platform to platform exchanges. Interoperability between BIM tools is limited as they have been developed in isolation and have different internal models and rules applied to objects.

Before data can be exchanged between a BIM platform and energy tools it often has to be adjusted. Cormier et al. (2011), Hitchcock and Wong (2011), Bazjanac and Kiviniemi (2007) and Wilkins and Kiviniemi (2008) suggest that the initial BIM model is an architectural view of a building, and it does not correspond to a “*thermal*” view necessary for performance analysis tools. Figure 4.1 shows the visual differences between the views. Figure 4.1 (a) is the architectural view of the building, which would describe for example the details of doors and connections between walls and floors. Figure 4.1 (b) shows the thermal view, which consists of a single line

representation of the building elements such as walls and windows. Cormier et al. (2011) explain that in order to transform from one view to another:

- the geometry necessary for an energy simulation needs to be simplified, and
- details about materials have to be added.



**Figure 4.1** Different views of a building (Bazjanac and Kiviniemi 2007), where (a) shows an architectural view and (b) shows a thermal view.

The benefits of automatically or semi-automatically transforming geometry between an architectural and thermal view include saving time and error reduction (Hitchcock and Wong 2011; Bazjanac 2008). The improvement of transferring data has been identified as being more important to the design of energy efficient buildings than creating more tools or graphical interfaces (Bazjanac 2008). The improvement is necessary as current practice relies on subjective and arbitrary decisions being made by humans.

In summary, the issues relating to interoperability are twofold. Firstly, data exchanges need to be standardised so two or more tools can communicate using the same concepts. Secondly, the data being transferred may need to be processed in order to become useful to a target application. This chapter therefore continues with a summary of standardisation and transformation efforts which address such interoperability issues.

## 4.2 DATA STANDARDISATION AND TRANSFORMATION EFFORTS

Data transfer between 2D CAD tools can be dated back to the late 1970s and early 1980s (Eastman et al. 2011). One of the first attempts to establish a single public exchange format was initiated by NASA, developed by Boeing and General Electric and resulted in the '*Initial Graphics Exchange Specification*' (IGES). IGES does not separate the format of the file, and its semantic content. This has changed in the past as the separation was found to be advantageous. An example is the ISO-STEP



data modelling language EXPRESS, which is used to describe product modelling technologies and schemas such as the IFC and the CIMsteel Integration Standard, Version 2 (CIS/2). Another widespread language used as a base for schemas is the eXtensible Markup Language (XML). XML schemas can be either public or proprietary. XML schemas can be part of the document that is being exchanged, or they can be defined externally. Additionally, direct links between software have been established. They are generally robust as they have been developed specifically for the software in question. They rely on the Application Programming Interface (API) from an initial tool to write data so it can be understood by the API of the target tool. Other standardisation efforts focus on more specific scenarios in data exchange such as the International Framework for Dictionaries (IFD), the OmniClass Construction Classification System (OmniClass) and the Construction Operations Building Information Exchange (COBie).

In the following some existing data standardisation efforts will be outlined, and will examine how data is exchanged between specific BIM and energy analysis tools.

#### *4.2.1 ISO STEP*

Before the adoption of BIM, the data that needed to be transferred between applications in most cases was simply 2D and 3D geometry. Data models such as IGES and the Drawing eXchange Format (DXF) were sufficient for this task. As the need to transfer more semantic data about various different systems grew, file exchanges became too large and complex. The International Standards Organisation (ISO) decided this issue needed attention, and through a Technical Committee (TC184) and a subcommittee developed the Standard for the Exchange of Product Model Data (STEP), number ISO-10303. The EXPRESS language was one of the products from this standard, and has been used in a wide range of domains. In order to facilitate its readability for humans, a graphical version was developed: the EXPRESS-G language. The STEP standard is public, and has led to several building-related product models being developed:

- STEP Application Protocol 225 (AP225): Building Elements Using Explicit Shape Representation (STEP Tools Inc. 2013). This was in addition published as the standard ISO 10303-225:1999. It is one of many Application Protocols. These standards share their contents. For example, if one defines how geometry should be described, and the others will refer to this description. AP225 can be used to exchange the shape, properties and spatial arrangements of items such as building elements, building services. It

has been implemented by many system vendors, in countries such as Germany, Belgium, USA and Japan (Haas 2000).

- IFC: a standard which describes the whole buildings lifecycle (buildingSMART 2013). It is widely used to exchange data by most BIM authoring tools. More information is given in section 4.2.2.
- CIS/2: a standard for structural steel project information (AISC 2013). It is supported by a large range of software, such as Autodesk Revit Structure.

CIS/2 and IFC are both public, and have been labelled as likely to become the international standard for data exchange (Eastman et al. 2011). The IFC is the most widespread and comprehensive model, and it is relevant to this thesis as it can describe a range of information about the geometry and properties of building elements. This is necessary for a data exchange between design and analysis tools. Consequently, it will be described in more detail below.

#### *4.2.2 INDUSTRY FOUNDATION CLASSES (IFC)*

This section includes an overview of the IFC schema, its extensions, different views of the model and IFC-based data transfer. The chapter often refers to concepts relevant to the transfer of building element data or to the structural analysis domain. A key reason for using the structural analysis domain is it can be used as a resource, from which an explicit energy analysis domain can be developed later.

##### **4.2.2.1 Overview and architecture**

The IFC enables sharing construction and facility management data. It is developed by buildingSMART International (buildingSMART International Ltd. 2013a), earlier known as the International Alliance for Interoperability (IAI). It is registered with the ISO as ISO16739. It should be noted that IFC stands for Industry Foundation Classes, but it is occasionally referred to as '*Information for Construction*' (Nisbet 2011; Plume and Mitchell 2007). Its chronological development can be found in Laakso and Kiviniemi (2012).

The '*current release*' is IFC2x Edition 3 Technical Corrigendum 1, otherwise known as IFC2x3-TC1. A new version of the schema, IFC4, was released in March 2013. When the IFC schema is mentioned in this thesis, IFC2x3-TC1 is being referred to. This schema contains 117 '*defined types*', 653 '*entities*', 164 '*enumeration types*' and 46 '*select types*'. These concepts all hold data differently. Defined types directly describe data, for example an '*IfcRatioMeasure*' holds a REAL data type, which

could be for example '5.2'. An entity describes objects, which have attributes that refer to other entities, defined types etc. An example is *'IfcWindow'*, which has the attribute *'OverallHeight'*. This refers to a defined type *'IfcPositiveLengthMeasure'*. An entity can have both direct and indirect attributes; the latter are inherited from its supertypes. Enumeration types can hold a selection of values that are predefined by the schema. For example, *'IfcBoilerTypeEnum'* can hold *'water'*, *'steam'*, *'userdefined'* and *'undefined'*. Select types means that one concept from a range can be used to describe it. If the select type *'IfcUnit'* is an attribute, in the resulting IFC file it will be represented by an *'IfcDerivedUnit'*, *'IfcNamedUnit'* or *'IfcMonetaryUnit'*.

The IFC data model is hierarchical, object orientated, and it is composed of several sub schemas. Figure 4.2 is diagram of the IFC architecture, and shows all the different data models that form the main schema. The IFC architecture is split into four layers (IAI 1999). The lowest layer is (i) the Resource layer. This holds concepts which describe properties such as geometry, material, quantity, date, time and cost. The second is (ii) the Core layer. This contains the Kernel and Core Extensions. The third is (iii) the Interoperability layer. This contains concepts which are common in a range of industries or applications. The highest layer is (iv) the Domain layer. This contains concepts specific to individual domains or applications. The architecture is based on a *'ladder principal'*, which means concepts can reference only to other concepts in their own layer, or one that is lower. For more information please refer to the schema documentation (Liebich et al. 2007). A short summary including some of the parts which are relevant to transferring data for an analysis is given in (i) to (iv) below. The areas described in more detail are circled in Figure 4.2.

**(i) The Resource layer**

The Resource layer holds concepts which describe properties which are generic. They are used by all the layers above to assign values to attributes. There are several data models in this layer, and each one represents an *'individual business concept'* (IAI 1999). For example, the data model *'IfcMeasureResource'* contains the defined types *'IfcLabel'* and *'IfcLengthMeasure'*. The *'IfcLabel'* is can be used by the entity *'IfcRoot'* (and subsequently by all entities derived from it) to describe its *'name'* attribute. The *'IfcLengthMeasure'* can be used to describe the *'ElevationOfTerrain'* attribute of the entity *'IfcBuilding'*. Another data model is *'IfcGeometryResource'*. This contains concepts such as *'IfcPlane'* and *'IfcCircle'*.

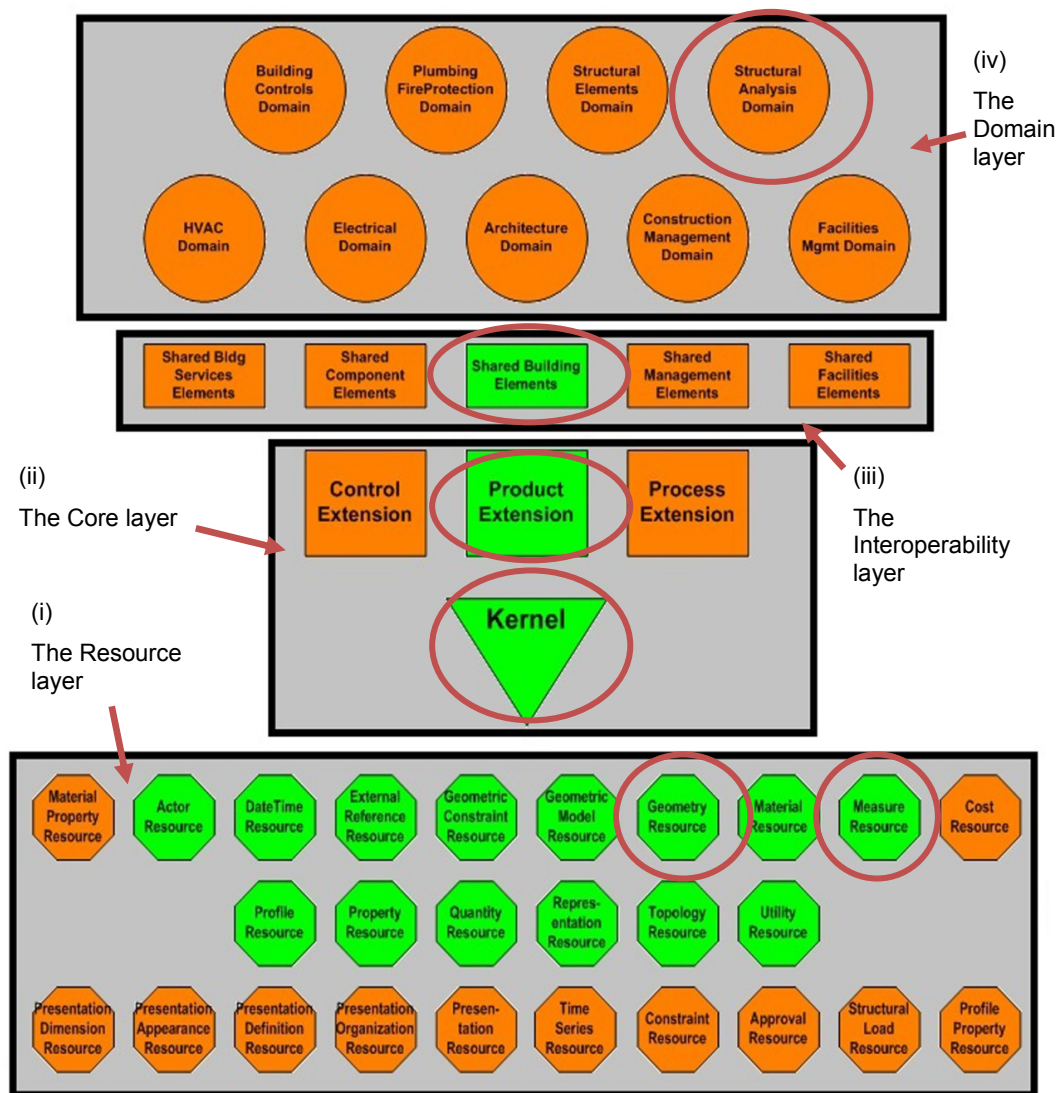


Figure 4.2 The IFC2x3 architecture showing the main layers in the schema, and what sections they are explained in. Adapted from (Liebich et al. 2007).

### (ii) The Core layer

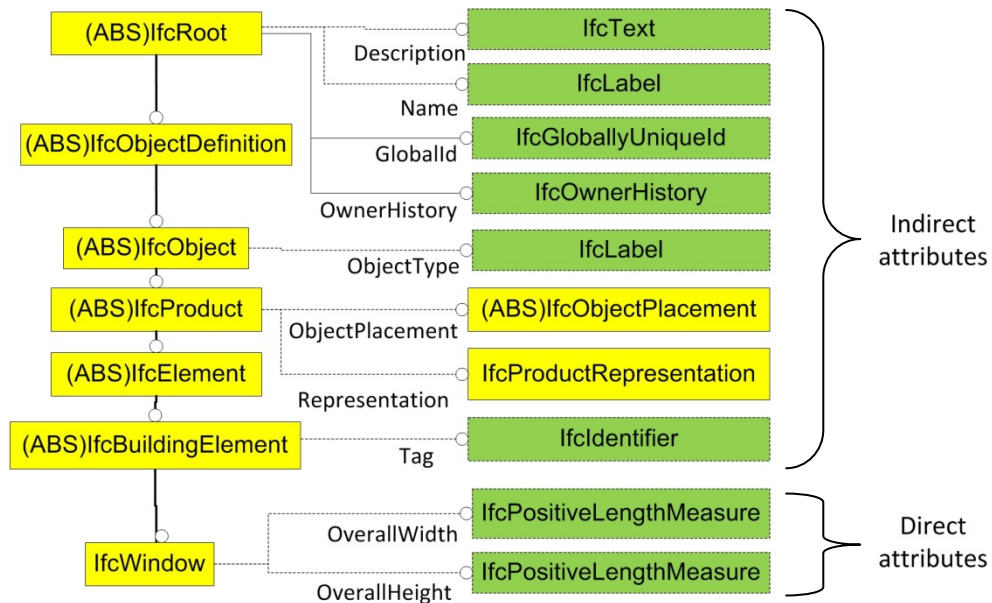
In the Core layer, the 'Kernel' shape represents the 'IfcKernel' data model, the part of the model defining the most abstract part of the IFC architecture. It contains the most abstract entity in the IFC hierarchical structure: 'IfcRoot'. General constructs such as object, property and relationship are found in this data model. These are derived from 'IfcRoot'. The abstract supertype 'IfcObject' represents all physically tangible things, for example building elements. Moreover, it can stand for work tasks, controls, resources and actors. The object is related to other objects through relationships, which are all derived from the objectified relationship 'IfcRelationship'. The properties are derived from 'IfcPropertyDefinition', and a single instance of a definition can be shared between many objects. In the hierarchical structure of the IFC, the object, property and relationship concepts are the first level of

specialisation. An example of a second level of specialisation is when the object is split into concepts such as product, process and resource.

The physical products are further specialised in the '*IfcProductExtension*' data model to basic concepts which include the spatial project structure and the element. The spatial project structure is important in geometry transformation, as it contains information on the location of entities such as site, building, building storey and space. The placement of objects can be relative to other objects, or absolute to the project world coordinate system. Spaces can be used for logical reasoning on the position of building elements, as the relationships of spaces and building elements is described by '*IfcRelSpaceBoundary*'. The specialisations of elements are necessary in transforming geometry, as they describe the generic entities '*IfcBuildingElement*' and '*IfcOpeningElement*'.

**(iii) The Interoperability layer**

The Interoperability layer contains the next level of specialisation of the building elements in the data model '*IfcSharedBuildingElements*'. This includes the entities '*IfcWall*', '*IfcWindow*', '*IfcRoof*', '*IfcSlab*', and '*IfcDoor*'. Figure 4.3 represents an EXPRESS-G diagram of the entity '*IfcWindow*', its supertypes and direct and indirect attributes. Examples of its supertypes are in the boxes located directly above '*IfcWindow*', so '*IfcBuildingElement*', '*IfcElement*', '*IfcProduct*' etc. Direct attributes are for example the '*OverallHeight*'. Indirect attributes are those inherited from its supertypes, and include '*ObjectType*'. The yellow boxes are entities, and the green boxes are defined types.



**Figure 4.3 An EXPRESS-G diagram of the IfcWindow entity, showing which are direct and indirect attributes.**

#### **(iv) The Domain layer**

The Domain layer describes entities only useful in a specific domain, for example the structural analysis domain. While structural concepts existed in the original IFC specification, there was not an explicit structural analysis domain. The original domains were only architecture, HVAC engineering and facility management. An extension for the most crucial structural analysis concepts that could be part of a structural domain was proposed by (Weise et al. 2000). The extension was kept at a minimum, in order to enable a quick release to the industry. Weise et al. (2000) argue that the structural model of a building has to be simplified in order to perform an analysis calculation. The concept '*IfcStructuralAnalysisModel*' is proposed to store the structural analysis version of the building as opposed to the original structural model. The other concepts in the structural analysis domain are concerned with describing connections and the structural representation of a model, and classes which describe action and reaction forces. The main limitation of this work is the extension "*captures a lot of information needed in proprietary structural applications for analysis*" (Weise et al. 2000 p.238), but does not validate this claim with a working model.

The work proposes the use of new property sets, which keeps the size of IFC down and supports the idea that it should be a framework. However, the use of property sets has some limitations. They are not part of the IFC EXPRESS schema itself, and so are not rigorously enforced in a specification (Fies 2012 p.5). Their use and composition has to be agreed between project participants, and they are not automatically exported from BIM applications.

#### **4.2.2.2 Extensions**

The actual extension of the IFC is an on-going process led by the results of many past and present projects (Liebich 2012). As part of this thesis involves analysing and extending the IFC, some details about previous extensions are given. Some of the extensions mentioned below are only proposed, whilst others are formally accepted. This is key, as it means work such as that undertaken in this thesis could be used as a contribution towards the development of an official extension.

The structural analysis domain was mainly developed in the '*ST-4 structural analysis domain and steel constructions*' project. It was initially proposed in 1998 but has since been revitalised. It adds structural analysis concepts to the IFC, and builds upon other projects (e.g. ST-1 and ST-2). This extension has since been developed further by Serror et al. (2008), to include an finite element model, dynamic loads and

analysis results. Their aim is to incorporate the IFC, the Standard for the Exchange of Product Model Data (STEP, ISO-10303) and CIS/2. They extended the domain and the resource layers of the IFC architecture. It has been assessed in a scenario of an earthquake occurring in a virtual city (80 buildings) to confirm its robustness and efficiency. The work of Serror et al. (2008) has been accepted as the formal 'ST-7' project, and their project is being supported by the IAI Japan Chapter. Out of all the formally accepted extension projects, it is the only project which is linked to the analysis of buildings.

A further project in the construction cost estimating domain included extending property sets and proxy elements (Zhiliang et al. 2011). It was proposed that an extension was necessary which described the physical and spatial components of road structures (Lee and Kim 2011). Neither of these papers shows case studies of how the extensions have been implemented as a validation, and to the author's knowledge the work has not been formally accepted. Another project was concerned with merging existing and popular standards together in order to form a single model. CIS/2 and IFC is being harmonised in the formally accepted ST-6 project, with expected changes applicable to the domain layer only.

An alternative to extending the IFC schema is to use existing concepts which can be used to define objects and properties that are not in the schema. This includes the entities '*IfcProxy*' which can describe objects, and '*IfcExtendedMaterialProperties*' which can be used to create user-defined properties for objects (Liebich et al. 2007). A disadvantage of using these entities is the application receiving them will in most cases be able to access them, but they will not be interpreted at a higher semantic level without some human intervention.

#### **4.2.2.3 Model View Definition (MVD)**

The IFC model is complex, as it has to describe a wide range of data exchanges that can occur in the construction industry (Howard and Björk 2008). Its richness was demonstrated by Venugopal et al. (2012), in an example where a slab could have four different representations depending on what it was used for. These are necessary for different purposes that include clash detection and precast fabrication. The ability to have different representations in an IFC file can lead to it being highly redundant, as BIM tools can map their internal objects to IFC entities and properties in various ways (Venugopal et al. 2012; Hitchcock and Wong 2011; Costa et al. 2013). Problems can occur as a result with data exchanges between different tools. This could be a problem for the transfer of geometry from BIM to energy tools, as it

has been identified that the choice of shape representations of objects can differ (Venugopal et al. 2012). Furthermore, the results from a study on expert's views on BIM show the IFC complexity can be a deterrent to potential users (Howard and Björk 2008).

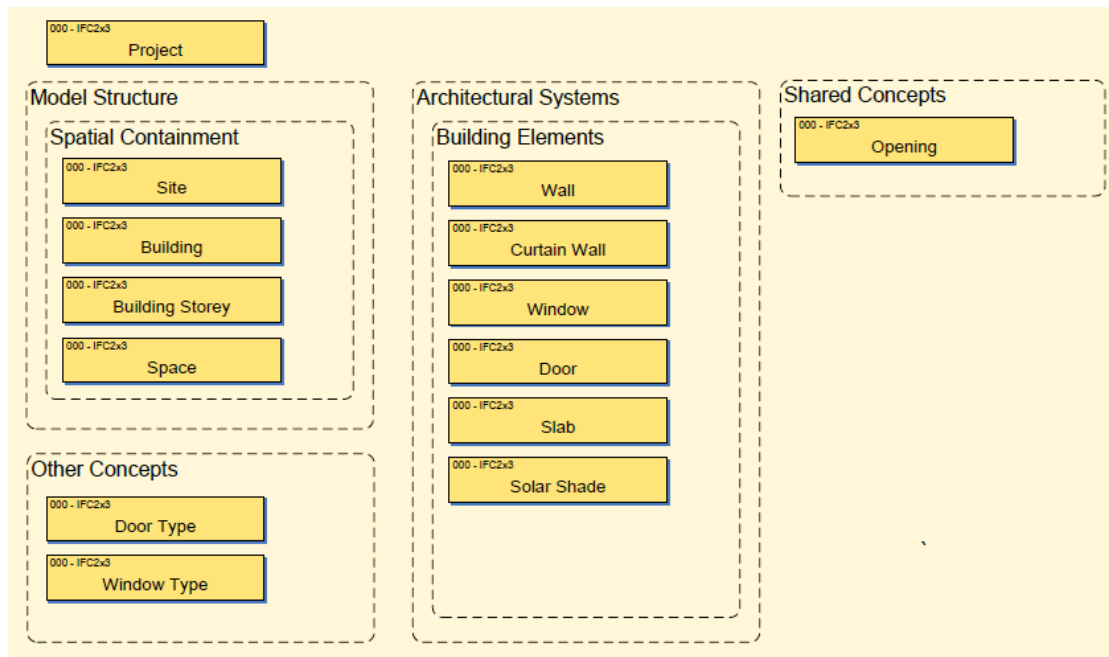
Simplicity could be achieved by using subsets of the IFC schema. This idea is supported by Eastman et al. (2011), who reasons that interoperability has evolved from simple data exchange between tools to supporting use cases defined by workflows. A Model View Definition (MVD) "*defines a subset of the IFC schema, that is needed to satisfy one or many Exchange Requirements of the AEC industry*" (buildingSMART International Ltd. 2013b). The exchange requirements must be identified using a Process Definition Standard (formally known as the Information Delivery Manual (IDM)). The buildingSMART teams have to review and accept proposals for MVD. The first MVD was the Coordination View (formerly known as the Extended Coordination View), and it is still one of the most popularly used (buildingSMART International Ltd. 2013b). Its purpose is to facilitate data transfer between architectural, structural engineering and building services tools. The IFC2x3 Structural Analysis View is another official MVD, and it covers the exchange of data between structural design and structural analysis tools.

A building performance could be analysed from many different aspects, and it has already been identified in section 1.1.1 that changes made at the conceptual design stage can have a large impact on a buildings performance. A project which addresses these issues is '*Concept Design BIM 2010*'. It is a collaboration between many countries, and involves the US GSA, Statsbygg and Senate Properties (for more information please refer to section 3.2). The project aims to enable building performance analysis at an early design stage in the following four areas: '*Spatial Program Validation*', '*Energy Performance Analysis*', '*Human Circulation and Security Analysis*', and '*Quantity Takeoff to enable Cost Estimating*'. MVD's were created for each area, which facilitate the exchange of data between BIM authoring tools and target design analysis tools.

The energy-related MVD is called the '*Nordic Energy Analysis (subset of CDB-2010)*' (BLIS Consortium and Digital Alchemy 2012). The specific organisations involved in its creation are: Statsbygg and Senate Properties, Datacubist, Digital Alchemy, Equa Simulation, and Granlund. The high level concepts identified as important in this MVD are summarised in Figure 4.4. The contents of this figure are part of a document which describes the MVD in more detail. It mentions other



concepts related to the high level ones; for example, a 'wall' entity will have attributes inherited from the 'root' entity, and it will have a 'shape representation'. The MVD does not describe all the concepts necessary for an energy analysis however, and a comprehensive list of both input and result parameters needed can be found in a report created as part of the AECOO-1 Testbed project (US GSA 2009). These research projects can be used as a starting point when analysing the IFC for pre-existing energy-analysis related entities.



**Figure 4.4 The Nordic Energy Analysis MVD (Jiri Hietanen 2011)**

It is key to note that a schema has been designed by O'Donnell et al. (2011), which aims to inform a new MVD which could enable data transfer between HVAC design and energy analysis tools. The schema is called '*SimModel*', and combines the IFC, EnergyPlus Input Data Dictionary, Open Studio IDD and gbXML. To the author's knowledge, this is one of the few research projects that could be used to extend the IFC schema with new concepts needed for energy analysis. The need for static and dynamic concepts to be stored alongside each other has been identified in (Rezgui et al. 2010), and an explicit energy domain in the IFC could enable this. Furthermore, it would provide a more rigid structure for the data transfer of energy concepts, reducing the ambiguity output of IFC files.

MVDs have been considered as another layer of specification above the IFC schema, and the process for developing a view has been described in detail in a report by the National Institute of Building Science (NIBS) called the United States National Building Information Modeling Standard (NBIMS) (NIBS 2007). The

process starts with a workgroup formation, which places creating a MVD outside the scope of this thesis. It does however present an argument that extending the IFC and therefore adding to its complexity is not problematic, as users can receive small subsets of data if they are using the MVD principle.

Other limitations of the IFC schema will be given in section 4.2.2.4, as they generally pertain to the data transfer between specific BIM and analysis tools.

#### **4.2.2.4 IFC-based data transfer and processing**

Utilising the IFC to transfer data between BIM and energy tools is an active area in literature (Welle et al. 2011; Bazjanac 2008; Costa et al. 2013; Hitchcock and Wong 2011; Cormier et al. 2011). Welle et al. (2011) combine energy and daylighting to support passive thermal multidisciplinary design optimization in a tool called ThermalOpt. The methodology starts with an IFC file being created using a BIM tool. This is converted into an intermediate text file and extra parameters which are needed are entered by the user. All the necessary information is then transformed into a relevant format by a wrapper, depending on the target analysis tool (daylighting simulation package called Radiance or EnergyPlus). Future development of this work is planned to include different types of analysis (CFD, structural analysis, space planning, and constructability), and to use knowledge based systems to lower simulation times. Cormier et al. (2011) took a different approach to linking tools, in which plug-ins were written for an IFC Viewer which enabled IFC files to be processed by simulation tools. The simulation tools used in their study are TRNSYS and EnergyPlus, and the IFC Viewer is eveBIM.

Another methodology was proposed by Bazjanac (2008). It was concerned with semi-automating building energy performance simulation and execution. It starts with populating an IFC-based BIM. The next step is to apply data transformation rules and check the model visually in order to identify and correct any potential issues. Finally, the energy simulation is run and the results are analysed. The study argued that BIM authoring tools should be able to transfer all the data which is necessary to run an energy simulation to an analysis tool, via the IFC. This includes parameters such as the length of the simulation (1 day, 6 months, etc.) and details about the ventilation system. The IFC should also be used to hold any data resulting from a simulation. This would introduce consistency, as simulations could be reproduced by other project members. The methodology was partly implemented using EnergyPlus and was found to reduce the time needed to create input files for testing by 70-80%. The main drawback to fully implementing the methodology was

that at the time there were no IFC compliant HVAC design tools. These types of tools have since then been developed and are publically available, for example MagiCAD (Progman Oy 2013a). In addition, the methodology assumes that an ‘*energy simulation*’ MVD exists, which is currently not the case. The tool developed, Geometry Simplification Tool, is used in other research by Lawrence Berkeley National Laboratory (See et al. 2011; Bazjanac et al. 2011), but is not yet publically available.

The issue not addressed by the studies above is the storage location of energy related data in the IFC, for example from simulation results. In order to promote output file uniformity, not only guidelines are important but also a rigid structure of energy concepts defining data such as heat gain and heat loss.

#### 4.2.3 IFD, COBIE AND OMNICLASS

When research efforts are being undertaken to support the digital transfer of data related to buildings, existing resources should be used. These can be either reused wholly (an extension to the IFC) or partially. Some examples of how resources are reused are given below:

- The International Framework for Dictionaries (IFD) is part of the standardisation work undertaken by buildingSMART (Bjørkhaug and Bell 2012). Objects defined in the IFC can have different names in different standards or languages. The IFD tries to map these terms to each other, to support data exchange between different tools. The standards used are international, public, and have been developed by ISO. It forms part of the core of interoperability as envisaged by buildingSMART: Digital Storage (the IFC), Process (the IDM) and Terminology (the IFD). It is different to the IFC as it does not map actual objects in a building, but it provides a meta-model of how it should be modelled uniformly. It has several limitations, for example its flexibility leads to instance models of questionable consistency (Beetz 2009), but this flexibility has led to several implementations: the Norwegian BARBi library, the Dutch LexiCon and EDIBATEC in France.
- The Construction Operations Building information exchange (COBie) project is concerned with describing the handover information between the construction team and the owner of a building (East 2013). It covers data in deliverables in all the design and construction stages. Paper based documents describing aspects of a building would have been presented to building owners in the past, describing aspects such as a list of equipment,

warranties, and replacement parts. COBie can be now used instead, and data is entered during the work stages before a building is fully built. A pilot version of the standard was released in an appendix in the US National BIM Standard (NBIMS) report (NIBS 2007); since then it was updated in 2010 to COBie2. COBie has also been implemented as part of the IFC standard.

- OmniClass Construction Classification System (otherwise known as OmniClass or OCCS) is a standard for “*organizing all construction information*” (OCCS Development Committee Secretariat 2013). It is based on ‘ISO 12006-2, *Organization of Information About Construction Works—Part 2: Framework for Classification of Information*’. It aims to join a collection of classification systems: MasterFormat, UniFormat and Electronic Product Information Cooperation. The terms are currently sorted into 15 tables, which are dedicated to construction topics such as ‘*Products*’, ‘*Tools*’ and ‘*Materials*’. It has been used to organise information by the US NBIMS (NIBS 2007). This standard is a guidance document, and establishes common concepts used in building information exchanges. It reuses existing resources, such as OmniClass, IFD and IFC. Furthermore, OmniClass contributed to the development of IFD and COBie. The IFD library has many areas of overlap with OmniClass. COBie stores data using the organisational structure of the OmniClass tables.

#### 4.2.4 EXTENSIBLE MARKUP LANGUAGE (XML) AND XML SCHEMA DEFINITION (XSD)

XML is another language used for the transfer of data. It uses predefined tags to describe the appearance of a Web page. XML tags must be custom defined by methods such as Document Type Declarations (DTD) or using external schemas. An external schema can be written in XML. It can be known as an XML Schema Definition (XSD).

A XSD consists of elements that are described by simple and complex types. Simple types can contain only text. Complex types can contain other elements, text, both or be empty. An example of an XSD is given in Figure 4.5. This shows an element called ‘*wall*’ which has a complex type, and three attributes. Each attribute is a simple element. The first is a material name, and can be a string of letters and numbers. The second is a boolean option, which enables the wall to be described as external. The third is its height, given as a number which can have a decimal point.

```

<?xml version="1.0"?>
<xs:schema xmlns:xs=http://www.w3.org/2001/XMLSchema>

<xs:element name="wall" type="wall" >
</xs:element>

<xs:complexType name="wall" >
  <xs:sequence>
    <xs:element name="materialName" type="xs:string"/>
    <xs:element name="external" type="xs:boolean"/>
    <xs:element name="height" type="xs:decimal"/>
  </xs:sequence>
</xs:complexType>
</xs:schema>

```

**Figure 4.5** The contents of an example XSD file, describing a wall element and three attributes.

Examples of schemas in the architecture, engineering and construction (AEC) industry include: ifcXML, OpenGIS, gbXML, aecXML, agcXML, BCF and CityGML (Eastman et al. 2011). The success of schemas has been attributed to their widespread adoption, and gbXML (gbXML 2012) has been labelled as one of the most ‘prevalent’ in industry alongside IFC (Dong et al. 2007). The ifcXML schema is a mapping of a subset of the IFC EXPRESS schema to an XML schema. The next sections will go into more detail into gbXML and ifcXML.

#### 4.2.4.1 Green Building XML (gbXML) schema

The gbXML schema was developed mainly to transfer data from BIM to analysis tools. It is currently supported by BIM vendors such as Autodesk, Bentley and Graphisoft. A detailed comparison between gbXML and IFC has been performed by (Dong et al. 2007). Differences found include:

- IFC can represent any geometry, whilst gbXML expresses objects as only rectangular shapes. This has been stated as ‘enough’ by Dong (2007). This is supported by the fact that most BPS tools are not compatible with complex geometry such as curved walls and roofs. It has to be simplified by segmentation (Bazjanac 2001). This process is also undertaken in some cases during the generation of IFC files. For an IFC-based transfer of data to an energy analysis tool, space boundaries are used to define the surfaces used in the calculations of heat transfer (Weise et al. 2011). Space boundaries can be defined as “*virtual objects used to calculate quantities for various forms of analysis related to spaces or rooms in buildings*” (Weise et al. 2011 p.4). There exist several levels of specialisation of boundaries. The first level simply bounds a space using building elements, whilst the others

take into consideration factors. These include a change in the wall assembly, or that the other side of a space bounding wall, there may be more than one bound space. The 2<sup>nd</sup> and 3<sup>rd</sup> level mandates that curved surfaces have to be segmented. It is recommended that a curve is split into segments at every 5-10 degrees of a curve. There may be other factors to be considered at this time, for example the location and number of skylights in a curved roof (Bazjanac 2001).

- IFC files use a '*top-down*' approach and are large and complex, whilst gbXML use a '*bottom-up*' and are less complex. The top-down approach means many elements are derived from abstract supertypes, and inherit attributes. In gbXML, all geometry information is simply described by the element '*Campus*'.

As a result, the gbXML schema is chosen to be extended with light related concepts by Dong et al. (2007). They claim prototypes based on gbXML are simpler to develop than IFC based prototypes, as gbXML is easier to understand without having to have some level of knowledge about all the elements. Whilst this may be true, the reasoning disregards one issue: it lacks consideration of the suitability of the gbXML geometry resolution for detailed daylighting analysis. The IFC geometry description is superior to gbXML, and if a detailed lighting analysis was going to be undertaken to yield photorealistic images (which tools such as Radiance can produce), the resulting images may not be satisfactory. Further research would be necessary to prove gbXML geometry is sufficiently detailed for lighting simulation. Also, in order to extend the IFC not all of the concepts need to be thoroughly understood: if a lighting extension was going to be added initially areas which are not relevant could be ignored, with a focus on solely the geometry and materials.

The gbXML schema was used to determine the interoperability between BIM based architectural models (Revit Architecture and Revit MEP) and building performance analysis tools (Energy Plus, eQUEST, Ecotect and IES<VE>) in a paper by Moon et al. (2011). The IFC and gbXML schemas are both mentioned, but only gbXML is used with no clear explanation on the choice. Moon et al. (2011) identified that interoperability is still not seamless. Each tool had limitations as to what it could import, and half of them (eQuest and EnergyPlus) initially need an interface to import the gbXML data. Problems with importing gbXML files into Ecotect and IES<VE> have also been reported by Welle et al. (2011). This highlights that even though gbXML is widely used, development is still necessary.

#### 4.2.4.2 ifcXML

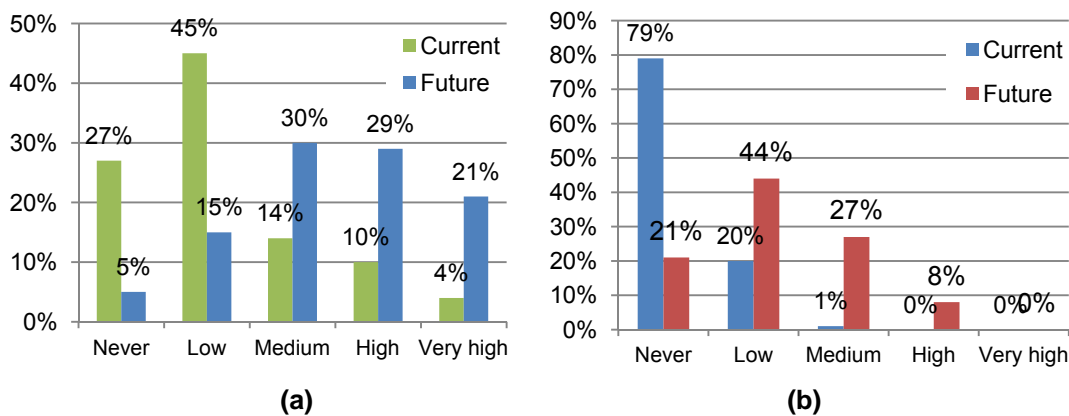
The ifcXML schema is targeted at developers and the XML community (Nisbet and Liebich 2007). The current version is based on IFC2x3 TC1, although the ifcXML release for IFC RC4 has now been made publically available. Its business motivation is to promote the use of the IFC schema to a wider audience. XML has a larger range of supporting tools and databases than EXPRESS, and it can be displayed using web browsers. Ilal and Macit (2007) claim that STEP based Physical File (SPF) tools require costly and complicated toolkits, a statement supported by Kim and Anderson (2013). They label XML tools as being more affordable and available. As ifcXML is an XML schema, it is relatively easy to extend with an external schema, avoiding the editing of the original schema. Expected application areas include mapping between the IFC model and document based representations, facilitating extraction, transmission and merging of partial models. Applications reading and writing in XML are not forecast to replace their EXPRESS counterparts, but to support them. A limitation of XML files is they can be between 2-10 times larger than its SPF equivalent (Nisbet and Liebich 2007). This is not a problem if the data being exchanged is a partial model, using for example a MVD. The ifcXML schema is generated using ISO 10303-28ed2 version of 05-04-2004, and it does not support some parts of the IFC schema such as rules, inverse relationships and derived attributes.

The ifcXML schema has been used in areas such as building automation network design, facility lifecycle information storing, acoustic simulation, querying models for spatial information and energy modelling (Karavan et al. 2005; Motamedi et al. 2011; Ilal and Macit 2007; Nepal et al. 2012; Kim and Anderson 2013). The literature reveals that the ifcXML does not yet benefit from a widespread adoption, and is rarely utilised in the BIM and energy field. It is used however by Kim and Anderson (2013), as part of a new methodology for running energy simulations from BIM-based models. The proposed process starts with exporting ifcXML files from BIM tools. Their prototype then reads and processes the files. Missing data can be entered via a graphical user interface (GUI) and an energy simulation input (INP) file is compiled for the chosen simulation tool DOE-2. The prototype can read data related to building elements and spaces to describe building geometry and thermal zones. The ifcXML files are parsed for this purpose using Ruby code. They use a typical office building in four different climates as a case study, and validate the methodology against a similar process using currently available BIM and energy simulation tools. The methodology allegedly provides '*energy simulations within*

minutes for designers to test various design configurations’, yet only geometry and thermal zone extraction has been specified so all the remaining data remains to be entered (e.g. duration of simulation, HVAC system, location, material definition etc.). The prototype is only set up to provide geometry for DOE-2, and the range of items it can read from an ifcXML file is limited. Its usability is also limited to the tools which can export ifcXML files.

### 4.3 ADDRESSING SPECIFIC INSTANCES OF DATA EXCHANGE

The literature review performed so far has highlighted that current data transfer is not seamless between BIM and analysis tools, yet some form is being adopted currently in Industry. McGraw Hill Construction (2010a) have published a report on an emerging practice Green BIM: ‘the use of BIM tools to help achieve sustainability and/or improved building performance objectives on a project’. The purpose is to assess the level and scope of Green BIM in industry, and used 182 architects and engineers, 233 contractors and 79 other industry respondents. Figure 4.6 shows that they found a ‘low’ level of BIM being implemented to simulate energy performance currently, with roughly equal hopes of achieving a ‘medium’ or ‘high’ level in the future by Green BIM practitioners.



**Figure 4.6 The current and future use of BIM to simulate energy performance by (a) Green BIM practitioners and (b) non-Green BIM practitioners. Adapted from (McGraw Hill Construction 2010a).**

Malin (2007) gives an overview of interoperability between some major BIM and BPS tools used in industry. By analysing publically available information about the capabilities of BIM and BPS tools, and an updated version including more tools is presented in Table 4.1. Most of the BPS tools have been mentioned in Chapter 2, as they can be used to certify buildings to rating systems and standards. The purpose of this table is twofold. Primarily, it is used to confirm the common transfer methods promoted by software vendors. Secondly, it is used to identify a possible route of data transfer that needs updating in order to support low energy design. The main



data transfer methods are plug-ins/add-ons, or using the IFC and gbXML schemes. The following sections (4.3.1 - 4.3.2) describe the findings in Table 4.1 in more detail. It is key to note that many of the tools in Table 4.1 can be used to provide data or even automate some part of a sustainable building rating or certification process. This means that the benefits and challenges caused by interoperability can directly or indirectly affect the design of sustainable buildings.

#### 4.3.1 PLUG-INS AND ADD-ONS

Plug-ins and add-ons are mechanisms utilised by several pairs of software. Integrated Environmental Solutions <Virtual Environment> (IES<VE>) provide a plug-in for Revit Architecture, Revit MEP and Google Sketchup (now called Trimble SketchUp) (Wheatley 2010). A study by Attia et al. (2012) shows that, out of ten popular simulation tools, the IES<VE> plug-in ranked as the preferred choice by architects but only received 5<sup>th</sup> position by engineers. The study argues interoperability should either be one '*common language like gbXML*' or computer-aided design should be fully IFC compliant. This complements the need for a single data model from section 3.5. The plug-in does have limitations that are arising from the difference in architectural and analysis views of a building and the use of gbXML itself. In order to try and address some related issues, IES<VE> have published a white paper describing modelling practices necessary to achieve cycles of analysis.

The plug-in has received attention from academia, with Crosbie et al. (2011) using it in the development of an Energy BIM. They emphasise that BIM lacks the capability to store all the information needed to perform an energy analysis. One of the aims of the project is to reduce the error produced between the predicted and actual energy use of a building. The difference has been documented as being up to 50%. The solution presented was a database of archetypal buildings and parameters which can be used as a reference. In the authors' opinion, the success of this study is very limited as the database will only cover certain building types and geographic locations.

Another plug-in named '*Solar Radiation Technology*' is reported by Gardzelewski (2009). It is used to perform an Ecotect solar analysis in Revit. However, the official workflow published in '*BIM for Advanced Daylighting*' (Skripac 2011) as part of Autodesk University 2011 does not mention such a plug-in. It runs through a process which is based on loading gbXML files into Ecotect Analysis. This could be used to assume that the plug-in is still being just tested, or that it was never developed further. This is supported by a mention of a new version of the plug-in

'Solar Radiation Technology Preview 2 for Revit 2011' mentioned on the Autodesk website (Autodesk, Inc. 2013b). A new Technology Preview is promised in that year, but there is no further evidence that it was ever released.

The CASBEE rating system is being supported by BIM using an Autodesk Revit Extension for CASBEE (Autodesk, Inc. 2013c). It will facilitate the assessment of 'Indoor Environment', 'Service Performance' and 'Energy'. Similarly, the energy calculations necessary for MINERGIE and MINERGIE-P certification can be performed from data originating from a BIM model through the tool Lessosai. The latest version '7.1' can import gbXML files which are created by Revit, Sketchup and ArchiCAD. In order to export to gbXML, Sketchup and ArchiCAD rely on the plug-ins. Sketchup can use the 'gTools' product (Greenspace Live Ltd 2012) and ArchiCAD can rely on Encina (Encina Ltd 2013).

A plug-in which could support the uptake of energy tools becoming IFC friendly is also currently under development, called 'BIM-tools' (BIM-Tools 2013). This focusses on the exportation of geometry from SketchUp into IFC files. This could enable conceptual designs to be exported to IFC compatible energy analysis tools, or to be imported by other BIM tools which in turn could send data to energy analysis tools.

#### 4.3.2 IFC- AND GBXML-BASED DATA EXCHANGES

The gbXML schema is used more often than the IFC for energy related data transfer. The preference is due to gbXML being the preferred schema by simulation tools, as can be seen in Table 4.1. BIM tools can generally generate both IFC and gbXML files. The only BIM platform that can be seen to favour gbXML is Bentley. The BIM products in this platform generate gbXML files, which are then processed by a range of analysis tools (Sokolov and Crosby 2011). These can be either Bentley tools such as AECOsim Building Designer, Bentley Hevacomp products, Bentley TAS simulator, or other non-Bentley gbXML compliant tools. IFC files can be imported by EnergyPlus, Ecotect Analysis and Riuska, whilst gbXML files can be imported by IES<VE>, Ecotect Analysis, Green Building Studio (GBS) and AECOsim Energy Simulator V8i.

Graphisoft has been actively supporting IFC development since 1996 (Graphisoft 2013b), and ArchiCAD can export both SPF and ifcXML files. It openly advertises its interoperability with a wide range of existing simulation tools (Graphisoft 2005), and its 'tight connection' to IES<VE> through gbXML (IES 2009). In addition, the newest version ArchiCAD 16 can perform hourly energy analysis. Not much information is

published by Graphisoft on the origins of the energy analysis, but a link is provided to a blog by Pickering (2012) who translates some parts from an evaluation from another Italian blog entry on their site. The blog entry explains that this new version of ArchiCAD has incorporated EcoDesigner into itself, one of their other products. It is identified that the tool plans to support the passive design of houses, but not enough information is given by Graphisoft to assert if this is a reasonable claim.

Autodesk Revit takes the opposite approach to Graphisoft. It can export data to all the simulation tools in Table 4.1 apart from PHPP, but it tends to focus its efforts on an integrated solution. Originally, it could generate a gbXML file which can be imported into GBS. This can be passed directly to Trace700, parsed to an input data file (IDF) for EnergyPlus or INP file for DOE-2 and eQuest (Scheer 2013). Part of this process has been automated by Autodesk 360 Energy Analysis tools being integrated with Autodesk Revit 2013 (combines Revit Architecture 2013, Revit Structure 2013, Revit MEP 2013) and Revit Architecture 2013 (Autodesk, Inc. 2013d). It uploads data straight to GBS, and uses the DOE2.2 engine for simulations. Another effort which attempts to integrate design and energy analysis is the Project Vasari from Autodesk (Vollaro 2013). It uses the DOE-2 simulation engine and simplified drawing capabilities from Revit to promote energy analysis in conceptual design. Embedding analysis tools into BIM tools has been done by Autodesk Revit and Ecotect (Gardzelewski 2009; Kachmar 2009), and Bentley and Hevacomp.

The process of embedding an energy tool into a pre-existing BIM tool has been undertaken by Schlueter and Thesseling (2009). In their study, Revit was extended to instantly calculate energy and exergy of a BIM model. An exergy analysis was included as it calculates how much energy is available to be used, thereby helping to evaluate the quality of an energy source. The interface to these functions was in the form of a toolbar, which can be used for additional user input and a graphical display of results. Only one type of analysis (energy) is examined, and the equations used are very simple and include many assumptions. These could all be argued as being examples of the development of interfaces, and not fixing issues with existing performance simulation tools, so '*contribute[s] relatively little to the design of more energy efficient buildings*' (Bazjanac 2008 p.5).

A general statement that can be made at this point is that detailed information on the energy analysis capabilities of tools is quite hard to find. Software vendors tend to state an overview of capabilities, but do not go into enough detail on subjects such

as what simulation engines are used for analysis and how they have validated their tools. Blogs seem to be the most easily accessible places for information and evaluations of tools. An example is a comparison of Ecotect's steady state calculation (based on the CIBSE Admittance Method) to Autodesk Vasari's whole building simulation by Malloy (2013).

PHPP's interoperability is very low compared to the other software presented in Table 4.1. Its MsExcel spreadsheet format may limit how it can be paired with BIM tools. There are however two main plug-ins available recently. The first is in the form of a SketchUp plug-in called '*designPH*'. It enables data transfer to the '*Areas*', '*Windows*' and '*Shading*' parts of PHPP (Edwards 2013). It transfers data using a file format developed by the PHI called '*PPP*'. No more information is given at the time of writing about the transfer process, or the file type. It has not been released yet to the general public. The other plug-in is called '*ph-tool*'. This is a Revit plug-in which transfers data about quantities, dimensions, orientations and area (Bjerg Arkitektur a/s 2013). There is no more information publically available on how the data is actually transferred. Furthermore, it only works for Revit Architecture 2012 and 2013, and the Autodesk Building Design Suite 2013.

Other efforts include '*workarounds*' (Duncan 2011; DesignReform 2011) a proprietary solution from ArchiCAD. Duncan (2011) focuses on exporting wall schedules from a BIM tool to PHPP, and DesignReform (2011) includes a few more building elements. These are all incomplete solutions as they only focus on exporting a section of information needed for an energy analysis. They are also time consuming, and prone to human error. It must be noted that ArchiCAD cannot be relied on for PHPP export. Version 15 has the ability to export some details to PHPP, but version 16 apparently does not have this option (Pickering 2012). However, a tool currently in the beta testing stage called EcoDesigner Star (part of the ArchiCAD 17 platform) includes an export to PHPP.

The current workflow involved with the design of a Passivhaus has been documented by Versele et al. (2009). The main processes are shown in Figure 4.7, in an IDEF0 diagram. This type of diagram can be used to show decisions, actions and activities using boxes and arrows. The boxes labelled '*A1*' to '*A6*' are the main functions. The arrows pointing to the left side of boxes are inputs, such as '*Site plan*' and '*Owner requirements*'. The arrows which start at the right side of a box are outputs, such as '*energy indicator for heating*' and '*BIM model*'. The arrows which point to the bottom of a box are mechanisms, and the arrows which point to the top

are controls. The main controls in Figure 4.7 are stated as environmental planning, the PHPP standard, consortium standards, EPBD regulations, Passiefhuis-Platform (PHP), and Plate-forme Maison Passive (PMP). PHP is a non-profit organisation which promotes the Passivhaus concept in Flanders, Belgium. PMP is the equivalent for Wallonia, Belgium. PHP and PMP advise on the Passivhaus concept, and certify Passivhaus buildings. The main actors in Figure 4.7 are a Passivhaus (PH) energy consultant, an ‘Energieprestatie en Binnenklimaat’ (EPB) reporter. EPB certification is concerned with the energy performance and indoor climate of buildings in Belgium. The diagram does not include where the engineer and architect would enter the workflow. Whilst Figure 4.7 is mostly relevant to Belgium, the pattern of tool use is similar in the UK, as BIM and PHPP have a low interoperability. What results is a process where there are a range of building models which all repeat data such as geometry and material properties. This data repetition could be avoided using data transfer.

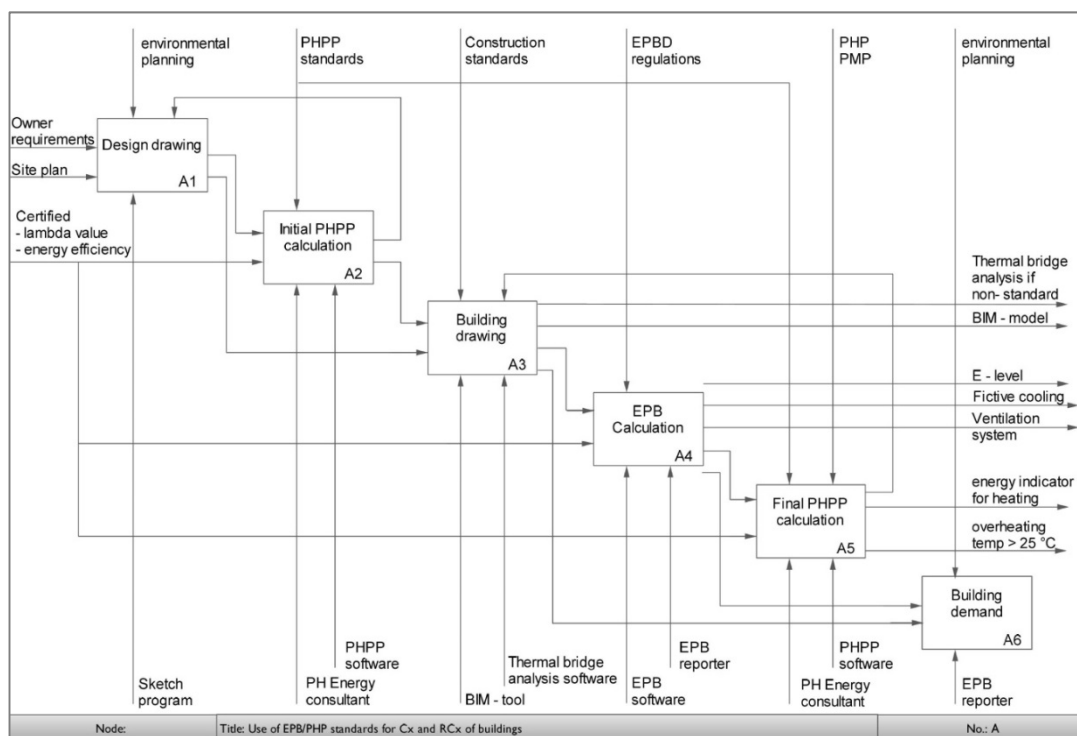


Figure 4.7 IDEF0 diagram of the use of BIM and PHPP in Belgium (Versele et al. 2009).

A reoccurring lesson from literature that must be kept in mind after the overview of potential interoperability is whilst tools claim to import/export gbXML and IFC data, in practice seamless integration is limited. Some issues with IFC and gbXML data transfer in tools have already been identified, and they are complemented by a study by Osello et al. (2011). It is one of the few examples of research which compare both IFC and gbXML data exportation. Two case studies test the data

export between the BIM tools Revit Architecture and Revit MEP, and the simulation tools Ecotect, IES<VE>, Daysim, Radiance and Trnysis17. They remark that the process of data transfer often includes either iteratively changing the architectural model or manually editing incorrectly imported geometry to achieve the desired results. Some data even has to be re-entered, and in some cases intermediate software has to be used. The gbXML schema was found to be far more capable than the IFC schema in exporting energy and lighting data. This is unsurprising, as the IFC does not have an energy or daylighting analysis domain (equivalent to the structural analysis domain), and none of the current or future formal extension projects are concerned with energy analysis. A positive outcome of the study and the on-going project is that there will be guidelines on how to prepare an architectural model for a successful exportation. One issue with this study is the tendency to only use one BIM platform. A more comprehensive study needs to be undertaken with a selection of BIM tools to make comments on the capabilities of IFC and gbXML schemas.

**Table 4.1 Interoperability between BPS and BIM tools, adapted from (Malin 2007)**

	<b>Autodesk Revit MEP and Architecture 2013</b>	<b>Graphisoft ArchiCAD</b>	<b>Bentley Architecture</b>	<b>Sketchup</b>
<b>IES &lt;VE&gt;</b>	Plug-in available from IES<VE>, based on gbXML.	ArchiCAD model can be exported to gbXML (using a third party add-on Encina) then imported to IES<VE>	IES<VE> can import Bentley generated gbXML or DXF file. The latter needs to be traced.	Plug-in available from IES<VE>, based on gbXML. Direct IES VE plug-in is one of Sketchup's toolbars. Connects to IES<VE> tools.
<b>Autodesk Ecotect Analysis</b>	Ecotect can import a Revit generated gbXML , IFC or DXF file. Ecotect solar analysis available in Revit through plug-in.	ArchiCAD model can be exported to gbXML (using a third part add-on Encina) or IFC, then imported to Ecotect.	Ecotect can import a Bentley generated IFC, gbXML or DXF file.	-
<b>Green Building Studio (GBS)</b>	Revit model generates gbXML file, imported into GBS. gbXML file passed to Trace700, IDF file passed to EnergyPlus, INP file passed to DOE-2 and eQUEST.	ArchiCAD model can be exported to gbXML (using a third party add-on Encina), then imported to GBS.	A gbXML file can be exported, and imported into GBS.	GreenspaceLive gModeller plug-in exports gbXML files which can be read by GBS. gbXML files can also be imported.
<b>EnergyPlus</b>	EnergyPlus can import a Revit generated IFC file.	EnergyPlus can import an ArchiCAD generated IFC file.	IFC file can be converted to an IDF file. GBS can be used to generate an IDF file from a gbXML file.	Building geometry for an EnergyPlus Input file can be created/edited using the OpenStudio plug-in. Results can be viewed from Sketchup.

	<b>Autodesk Revit MEP and Architecture 2013</b>	<b>Graphisoft ArchiCAD</b>	<b>Bentley Architecture</b>	<b>Sketchup</b>
<b>Passive House Planning Package (PHPP)</b>	Plug-in available for Revit which exports to PHPP. Data can be exported to xml files, then copy and pasted into spreadsheet. Work is also under development by Joerg Thone.	EcoDesigner Star tool in beta testing stage (from the ArchiCAD 17 platform) can export to PHPP.	-	Area information can be exported in CSV file, which can be linked with the appropriate PHPP spreadsheet. Sketch-up plug-in transfers data to PHPP.
<b>AECOSim Energy Simulator V8i (AES), Bentley Hevacomp, Bentley TAS Simulator</b>	Revit generated gbXML model can be imported.	Revit generated gbXML model can be imported.	Revit generated gbXML model can be imported.	Revit generated gbXML model can be imported.
<b>Riuska</b>	IFC file can be imported by Riuska, an energy tool based on the DOE 2.1 E engine	IFC file can be imported by Riuska, an energy tool based on the DOE 2.1 E engine.	IFC file can be imported by Riuska, an energy tool based on the DOE 2.1 E engine	
<b>Lessosai</b>	Revit generated gbXML model can be imported.	ArchiCAD generated gbXML model (using plug-in) can be imported.		SketchUp generated gbXML model (using plug-in) can be imported.
<b>Others</b>	Autodesk 360 Energy Analysis.  Autodesk Vasari data transferred to Revit.  CASBEE Revit Architecture Extension released.	Direct API link exists for ArchiPhysic, using a plug-in.		BIM-tools plug-in exports IFC geometry from SketchUp, still under development



#### 4.4 CONCLUSIONS

The main aim of this chapter is to examine the challenges that need to be faced to achieve seamless interoperability between BIM and energy analysis tools. The following conclusions can be made on this subject:

- Interoperability enables the exchange of data between various sources in a variety of ways. In the past, file-based exchanges transferred only geometry, such as the DXF format and direct links between tools were developed based on APIs. Exchanges have since developed to describe the exchange of products or objects using data models such as IFC and gbXML. (Section 4.2). *In order to support interoperability, further development of neutral data exchange formats should therefore be encouraged.*
- The IFC have been labelled as rich but can be redundant. MVD is a mechanism which can be used to reduce the complexity, as only part of an IFC data model is exchanged. The IFC claim to describe the whole building lifecycle, but it has had to be extended many times to allow specific data exchanges. It has also been noted that whilst it supports structural analysis, it lacks an explicit energy analysis domain. A MVD does exist which can be used in the transfer of data for an energy analysis, but the IFC still lacks many concepts necessary to describe an analysis and its results. The IFC has been extended on many occasions, but temporary user-defined objects and properties can be used when necessary concepts are not present in the current release of the IFC. (Section 4.2.2). *There is an opportunity to support the transfer of data to energy analysis tools by extending the IFC with energy analysis concepts.*
- The OmniClass classification system has been used in the development of IFD and COBie. These three standardisation efforts are also used by the US to produce the National BIM Standard. (Section 4.2.3). *Existing resources should be reused and combined in the development of new standards. As IFC and gbXML has already been combined in a research project, it would be useful to extend the IFC from a different perspective: using specific concepts from a BPS tool that has low interoperability with BIM tools.*
- The IFC schema is defined in two formats: EXPRESS and XML. The XML version was developed to encourage development, as there are more tools and a wide XML community. Additionally, it enables extending the IFC

schema without editing the original schema, which eliminates accidental change to the existing IFC definition. (Section 4.2.4.2). *Initial additions in IFC could be easier to implement and test using the XML version of the schema.*

- The main data transfer methods include creating plug-ins and embedding tools, and relying on the IFC and gbXML schemas. It was identified that the PHPP tool has very limited interoperability with BIM tools. Some efforts exist, but they all link specific BIM tools to PHPP. Similarly, CASBEE appears to have limited interoperability. (Section 4.3). *Developing existing neutral data transfer schemas will benefit more tools than concentrating on specific tool to tool exchanges. In addition, an extension to the IFC should be focussed on supporting sustainable design, and therefore the PHPP design tool is an ideal candidate to inform extension concepts. There is a need for a tool which could transfer data from any BIM tool to PHPP. There is also a need to develop a neutral solution for CASBEE, but it will not be addressed in this thesis.*

## Chapter 5 THE PASSIVBIM SYSTEM DEVELOPMENT

A brief introduction to the PassivBIM system is presented at the start of this chapter, and reasons are given for choosing to address the interoperability issues of PHPP (Section 5.1). It continues by identifying the data required for the PHPP heat demand calculation (Section 5.2). The chapter then outlines the development of the PassivBIM system (Section 5.3). The first stage was to analyse the IFC schema for existing energy concepts, and extend it based on the PHPP related data identified earlier (Section 5.4). A template document was then created which supports the transfer of data from PHPP to the final tool (Section 5.5). The second stage was to implement the extended schema into a Java tool which can read and process IFC files (Section 5.6). A more detailed account of the necessary adaptations to the IFC geometry so it is PHPP compatible can be found in Appendix B. Finally, some conclusions were made on the implementation of the PassivBIM system (Section 5.7)

### 5.1 INTRODUCTION

This chapter describes the extension of the IFC with an energy domain, and the implementation of a prototype based on the extension which will be further referred to as the '*PassivBIM*' system. The system aims to facilitate low energy design from a BIM-based environment. The overall solution is BIM tool independent, as it extracts building geometry from a neutral data transfer schema. It utilises the benefits of both the IFC SPF and the XML file format as: (a) the system can read IFC files and (b) extension is performed on the ifcXML schema. According to Figure 3.1, the tool can be classified as Level 2 as information is stored in a BIM model and tools are being integrated. As IFC are used for data exchange, the tool is partially Level 3. Before it could call itself fully Level 3 compliant, data would have to be stored on a central server. It is important to note that the PassivBIM methodology does not attempt to create a MVD. Section 4.2.2.3 identified that the development of a MVD starts with a workgroup formation, and so it is outside the scope of this thesis.

The PassivBIM approach can be easily adapted for any analysis tool. All that is necessary is the data required for its analysis calculation has to be identified. The IFC can then be again revised and extended. If the analysis is concerned with energy, then the extension proposed in this thesis could be used, and modified accordingly.

The analysis tool used in this thesis is the PHPP. It was chosen as a case study for three main reasons:

- Firstly, its interoperability with BIM tools is very low and limited to certain proprietary products. It would benefit the most from a neutral data exchange process.
- Secondly, the calculations performed by the tool are not hidden by an interface, and the main equations are even summarised in the PHPP manual. This encourages the user to understand how all the variables are related.
- Thirdly, there is only one tool that can be used for the Passivhaus certification process. This means any developments that make this tool easier to use will benefit the whole Passivhaus community.

## 5.2 DATA TRANSFER REQUIREMENTS OF THE PHPP ANNUAL HEAT DEMAND CALCULATION

Before the IFC can be revised from an energy analysis perspective, the data input and output requirements of PHPP's annual heat demand calculation must be identified. This information can then be used to revise the IFC schema. In addition, the format that the geometry needs to be in for the transmission heat loss calculations must be established. This enables the design and implementation of algorithms within PassivBIM which can process IFC geometry so it is PHPP compatible.

### 5.2.1 VARIABLES IN THE ANNUAL HEAT DEMAND CALCULATION

The version of PHPP that is used in this thesis is '*PHPP 2007*'. Since the release of this version, there have been two updated versions: '*PHPP 8 (2013)*' and '*PHPP 7 (2012)*'. The 2013 version is not yet available in English. The 2012 version only differs from '*PHPP 2007*' in minor aspects such as there is a tool for metric-IP conversions, various ventilation units can be entered, and the windows sheet has been improved. This does not affect the work undertaken in this thesis, so '*PHPP 2007*' was deemed as sufficient. From herein, when PHPP is mentioned, '*PHPP 2007*' is being referred to.

PHPP consists of an MsExcel based calculation workbook and a handbook. The workbook consists of different sheets, such as '*Areas*', '*Windows*' and '*Shading*'. Each sheet calculates values that are used for the final energy calculations, such as

the peak load and the annual heat demand which is defined in section 2.4. An overview of how the different worksheets in PHPP are related to each other can be found in Appendix D. Whilst there are several predefined climates in PHPP, there is also the option for user defined climate data which can be imported from other tools such as Meteonorm (Meteotest 2013). One study has used this mechanism to predict the future behaviour of buildings, by developing future weather climates compatible with PHPP (McLeod et al. 2012a). The values that are calculated by the annual heat demand worksheet are summarised in Table 5.1. The equations that the variables are part of can be found in Appendix C.

**Table 5.1 Heat gain and loss variables in the PHPP annual heat demand worksheet.**

Heat loads and gains	Variables necessary for the heat gain/loss calculations	Secondary calculation
<b>Transmission heat loss (<math>Q_T</math>) (kWh/a)</b>	Area (A) ( $m^2$ )  U-Value (U) ( $W/m^2K$ ) Reduction factor for reduced temperature differences ( $f_T$ ) Temperature difference time integral ( $G_t$ ) (kKh/a)	
<b>Ventilation heat losses (<math>Q_V</math>) (kWh/a)</b>	Effective air exchange rate ( $n_v$ ) (1/h) Volume of the ventilation system ( $V_v$ ) ( $m^3$ )  Specific heat capacity of air (c) ( $Wh/m^3K$ ) ( $G_t$ )	Treated Floor Area (TFA) ( $m^2$ ) Average room height (m)
<b>Total heat loss (<math>Q_L</math>) (kWh/a)</b>	$(Q_T)$ $(Q_V)$	
<b>Internal heat gains (<math>Q_I</math>) (kWh/a)</b>	'kh/d' (no units, equal to 0.024) Length of the heating period ( $H_T$ ) (d/a) Internal gains estimated for standard living conditions ( $q_i$ ) ( $W/m^2$ ) TFA (m)	
<b>Solar heat gain (<math>Q_S</math>) (kWh/a)</b>	Reduction factor (r) Degree of solar energy transmitted through glazing normal to the irradiated surface (g) Window opening area ( $A_w$ ) ( $m^2$ ) total radiation (G) ( $kWh/m^2a$ )	
<b>Free heat gains (<math>Q_F</math>) (kWh/a)</b>	$Q_I$ $Q_S$	
<b>Useful heat gains (<math>Q_G</math>) (kWh/a)</b>	$Q_F$ Utilisation factor ( $n_G$ ) (kWh/a)	$Q_L$ $Q_F$
<b>Annual heat demand (<math>Q_H</math>) (kWh/a)</b>	$Q_L$ $Q_G$	
<b>Normalised annual heat demand (<math>q_H</math>) (<math>kWh/m^2a</math>)</b>	$Q_H$ TFA	

### 5.2.2 GEOMETRICAL DATA NEEDED FOR PHPP CALCULATIONS

In order to calculate the transmission heat loss in the annual heat demand worksheet in PHPP, the area of the following has to be calculated in square meters:

- Exterior walls (facing ambient air and the ground). The external face of an ambient wall is used as a starting point, and it is then adapted. If the main insulation is above the uppermost ceiling and not in the roof rafters, only the area of a wall face up to the height of the top of the insulation counts towards the external wall area. In addition, if there is an air gap between cladding and the wall through which air can flow, the cladding is not included as part of the external wall area. Ground facing walls are not currently handled by PassivBIM, and so will not be discussed here.
- Treated Floor Area (TFA). The treated floor area is the floor area inside a thermal envelope. It is calculated according to the German Floor Area Ordinance. There are many rules in its calculation, most of which are described in by Hopfe and McLeod (2010). A revised version of this document is currently in progress.
- Windows and external doors. These are calculated by multiplying the total height and widths. The window areas also need to be associated with an orientation for the solar heat gain calculation. The orientation necessary for the final annual heat demand calculations can be: north, east, south, west and horizontal. It is key to note that initially, in the '*windows*' worksheet of PHPP the orientation is entered to the nearest degree, but PassivBIM currently does not replicate the calculations in this worksheet so this degree of accuracy is unnecessary for the prototype at this stage.
- Roof/ceiling. As with the external wall, the location of the main upper insulation has an impact on the roof. If the insulation is above the highest ceiling, the ceiling area is used as the roof area. If the insulation is in the roof, the actual roof area is calculated based on the roof panels. Any overhangs must be removed, as they are not considered as part of the thermal envelope.
- Floor slab. The floor slab area is the area of the lowest floor, and it includes the footprint of the external walls.

- Thermal bridges. Thermal bridges are generally calculated by two dimensional heat flow calculation programs (Feist 2007b), and so will not be extracted from the IFC.

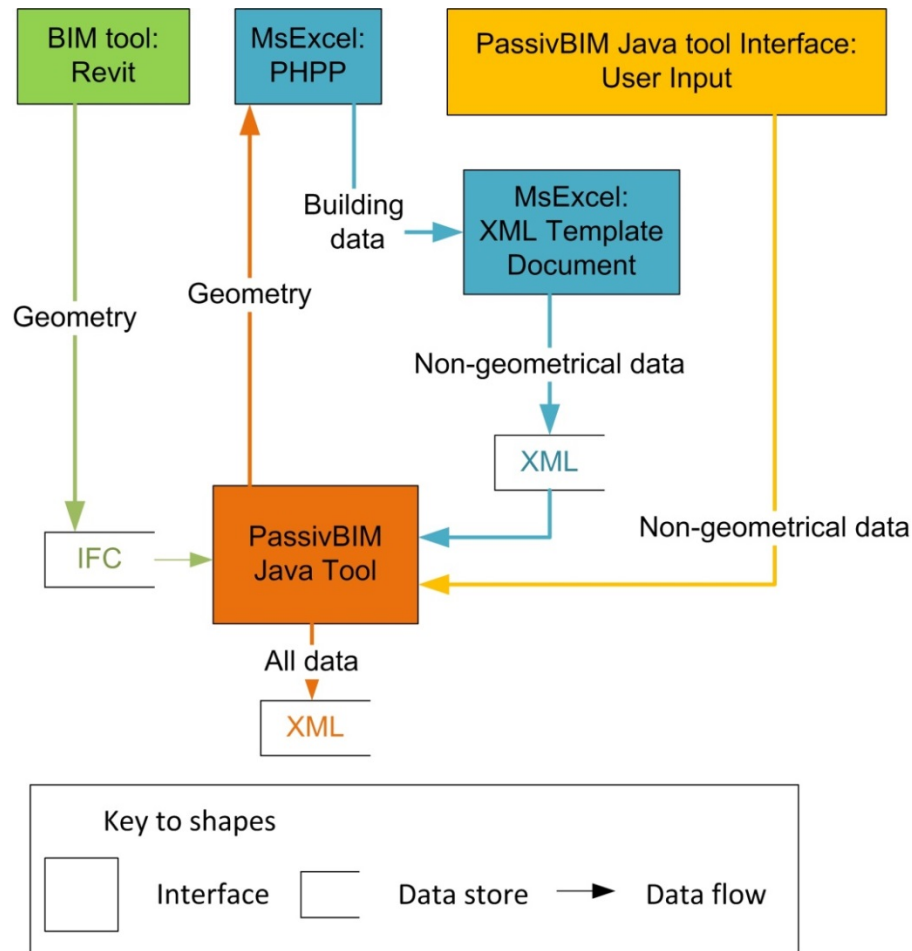
In order to calculate the annual heat demand, shading is also calculated by the '*shading*' worksheet. This involves the calculation of a shading factor which is later used to calculate the solar heat gain of windows. This factor relies on the window orientation to be accurate to the nearest degree. The calculations of the shading worksheet are not undertaken by PassivBIM, as the current prototype concentrates on only the final stages of the annual heat demand calculation, and extracting the geometry necessary for the transmission heat loss calculation.

### 5.3 THE PASSIVBIM SYSTEM OUTLINE

The workflow of designing a Passivhaus shown in Figure 4.7 (Section 4.3) presented six stages of building design (Versele et al. 2009). The PassivBIM system attempts to harmonise the first three stages (design drawing, initial PHPP calculation, building drawing) and the fifth stage (final PHPP calculation). This is implemented by storing BIM and PHPP data alongside each other and introducing an '*alternative design*' mechanism, the latter which is also proposed by O'Donnell et al. (2011).

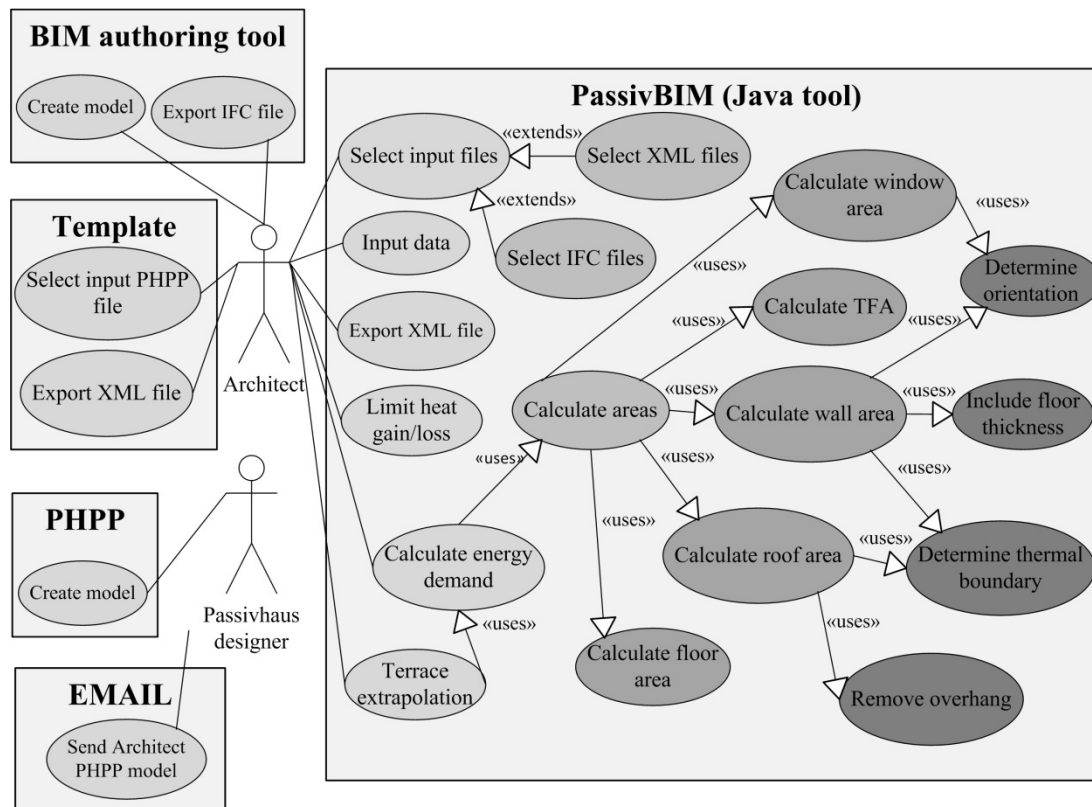
An outline of the PassivBIM system is shown in Figure 5.1. It demonstrates the flow of data in the system. The three main streams of input originate from a BIM tool, PHPP and user input. The PHPP building data is converted into an XML file so it can be read by the PassivBIM tool, and the BIM tool exports IFC files. The PassivBIM tool can then export the geometry of a building into PHPP, and create an XML file which can hold all the data being transferred around the system.





**Figure 5.1 A Gane-Sarson diagram showing a high level view of the data flow of the PassivBIM system.**

A use case diagram of the interaction between users of the PassivBIM system is presented in Figure 5.2. It includes various tools needed for the input of data, and the Java tool that processes it. The use case diagram shows that the system can be applied to the existing workflow. The main input needed by a Passivhaus designer is an initial PHPP model, which can be refined later. The main difference is that this model does not need to include area information for building elements. This model then needs to be sent to the architect, via a medium such as email. The architect can now create a building model from a BIM tool such as Autodesk Revit, and export it to an IFC file. A Template XML document is then used to select the PHPP model from the Passivhaus designer, and automatically translate it into an XML file. The architect can now use the PassivBIM Java tool to import multiple IFC and XML files, and calculate the annual heat demand. If the Architect does not want to use a PHPP model as input, non-geometrical data can be entered by hand into the PassivBIM Java tool. Several IFC and PHPP models can now be compared within PassivBIM. In addition, there are various functions which can be used to inform design decision making, for example the terrace extrapolation function.



**Figure 5.2 UML case diagram of the interaction between architects, Passivhaus designers and the PassivBIM Java tool.**

The interaction between PassivBIM and an architect can be further illustrated using a UML sequential diagram. Figure 5.3 depicts an architect using PassivBIM to calculate the annual heat demand from a BIM model. PassivBIM is split up in the diagram into the package *'OpenIfcToolkit'*, and the Java classes *'EnergyApp'* and *'ExtractIfcGeometry'*. All parts of the diagram will be explained in more depth in the remaining sections in this chapter. It is assumed that the Template XML document is not necessary in this case, but that the architect will enter all the non-geometric data needed themselves. Figure 5.3 describes the following process:

- The first message sent from the architect to Revit is a request for an IFC file, and an IFC file is exported.
- The second main request from the architect is the annual heat demand from PassivBIM.
- In order to calculate the annual heat demand, *'EnergyApp'* requests an IFC file, and then other input data such as building elements U-values and the ventilation system efficiency.

- Once the IFC file has been received by 'EnergyApp', it uses the package 'Open IFC Toolkit' (Open IFC Tools 2012) to read the IFC file and turn it into a Java class which can be read by PassivBIM.
- The 'EnergyApp' class creates an instance of the Java class 'ExtractIFCGeometry'. The 'ExtractIfcGeometry' class requests the 'ifcModel.java' class generated by the Open IFC Toolkit, and processes the geometrical information in the file into a format compatible with PHPP calculations. It passes the information back to the 'EnergyApp' and the 'ExtractIfcGeometry' class is destroyed as it is no longer necessary.
- The annual heat demand is calculated by the 'EnergyApp' class and the results are returned to the Architect.

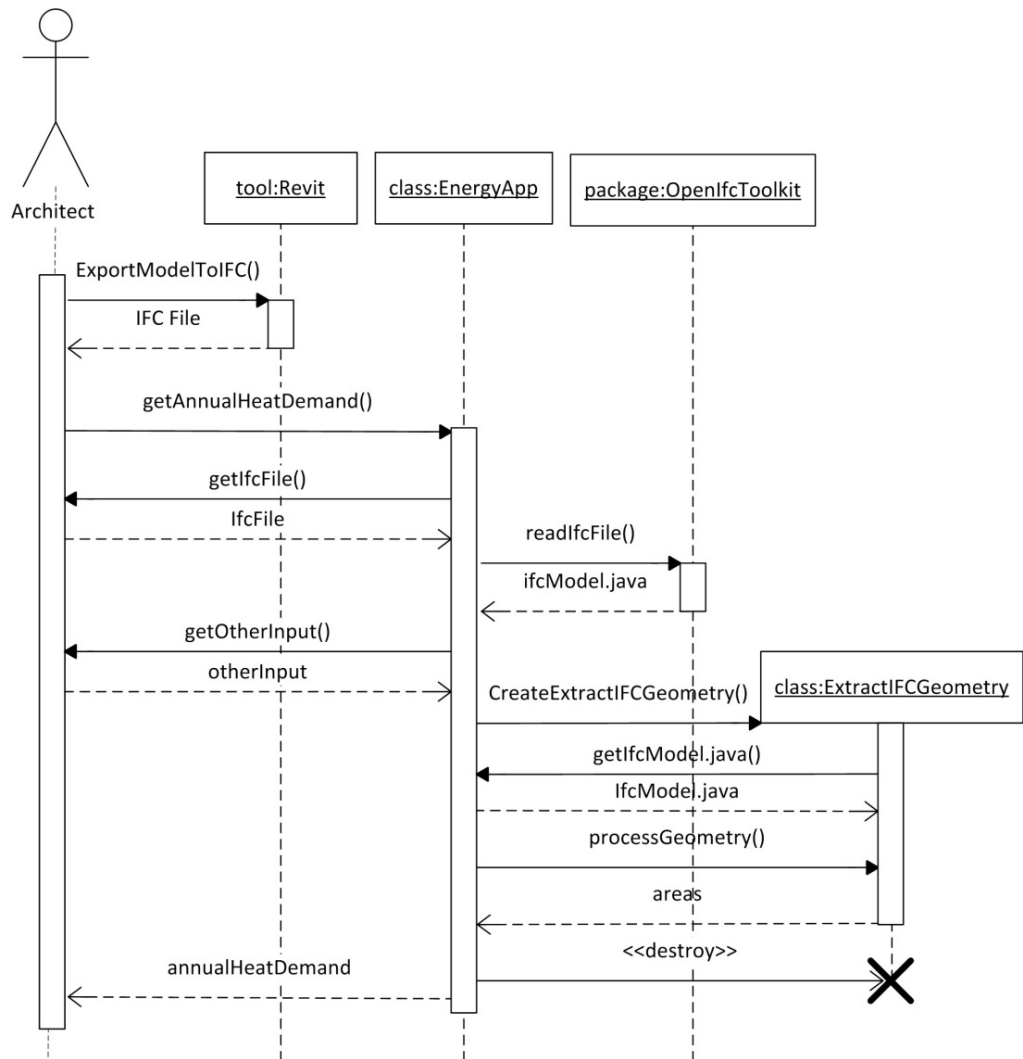


Figure 5.3 A UML sequential diagram showing the calculation of annual heat demand when the user enters non geometrical data and an IFC file is used for geometry.

The implementation of the main components of the PassivBIM system is shown in Figure 5.4, along with the thesis sections that they are described in. It is a data flow diagram of the process of creating an extended IFC schema, the PassivBIM Java tool and the XML Template. There are three main groups of processes:

- Energy concepts were taken from PHPP and inserted on top of the existing IfcXML structure to create an energy analysis extension '*IfcXmlEnergyAnalysisExtension*'.
- A simplification of the '*IfcXMLEnergyAnalysisExtension*' schema is mapped to a spreadsheet in which a macro imports data from PHPP models. This spreadsheet can be used to export PHPP data into XML files, and forms the '*XML Template document*'.
- Meanwhile, the full IFC extension '*IfcXmlEnergyAnalysisExtension*' is translated into Java classes using the data binding capabilities of Liquid XML Studio 2011. The resulting packages form the basis of the '*PassivBIM Java Tool*'. They are joined by others from the Open IFC toolkit project to enable them to read IFC files. The PassivBIM tool is now ready for an '*EnergyApp*' class and '*ExtractIFCGeometry*' class to be written, which will contain functions that will read/write files, process geometry and calculate heat demand. The next section contains more details about the individual components of the PassivBIM system which have been outlined.

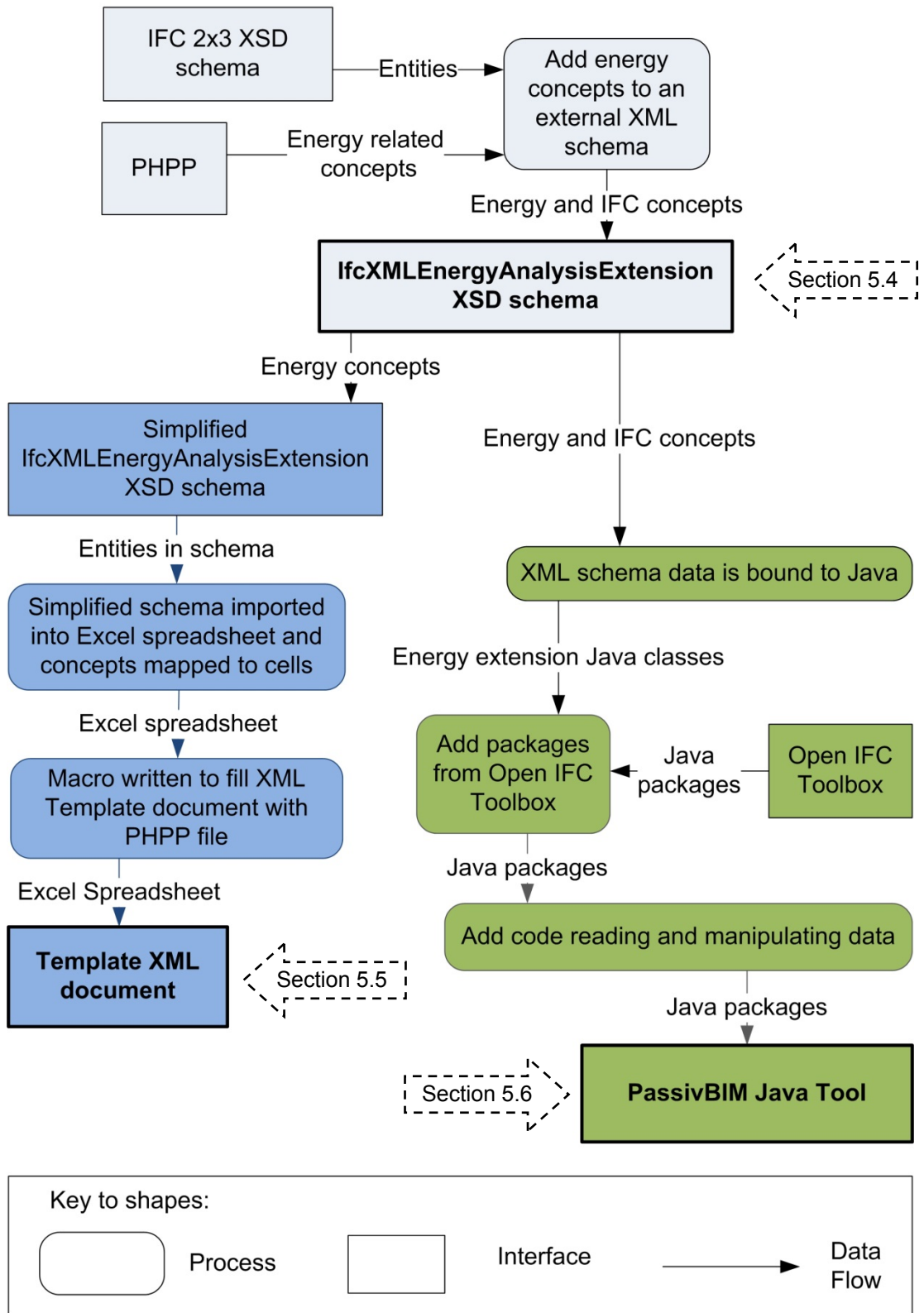


Figure 5.4 A Gane-Sarson diagram outlining the data flow involved in the development of the main components of the PassivBIM System. The dotted arrows refer to the thesis section which describes these components in more detail.

## 5.4 IFCXMLENERGYANALYSISEXTENSION

The ifcXML schema is extended in this section as opposed to the EXPRESS schema. The reason for this was twofold. It was identified in section '4.2.4.2' that there are tools available that can modify an XML schema, and a schema can be extended externally to the document containing the original schema. The schema is extended by creating an external XML schema document, and referencing the original at the beginning. This enables utilising and building on existing IFC entities without the risk of changing the original schema through human error. It also keeps the extension separate, so it could be developed more easily in the future. This is similar to using the MVD philosophy of describing exchanges using subsets of schemas. The ifcXML 2x3 TC1 version of the IFC is used as XML schemas can be used to export data from the Microsoft Excel application, which is the base of PHPP. The extension schema will have the file type of 'XSD'. At the time of the extension development, an ifcXML version of IFC4 was not available, but the Ifc2x4 RC3 change log was kept in mind in order to not use IFC entities that were predicted to be removed in the next official release.

### 5.4.1 IDENTIFYING EXISTING ENERGY CONCEPTS IN THE IFC SCHEMA

In section 5.2.1, the variables necessary for a heat demand calculation in PHPP were summarised in Table 5.1. These variables along with other trivial values (e.g. building name) in the '*annual heat demand*' spreadsheet (in PHPP) form the data that is required in a data transfer schema which aims to support PHPP. In order for the IFC schema to transfer data about the annual heat demand, the required data must exist in the IFC schema. If it does not, concepts such as entities and defined data types must be added to it. After an evaluation of the existing energy related concepts, the items below were identified as relevant to the PHPP calculations:

- '*IfcBuilding*'. This entities attributes store the buildings name, type and address.
- A whole range of '*defined types*' from the '*IfcMeasureResource*' such as '*IfcAreaMeasure*', '*IfcSpecificHeatCapacityMeasure*' etc. which can be used by concepts to hold data.
- '*IfcZone*'. Only one instance is necessary for a PHPP calculation as this tool assumes there is only one thermal zone.
- The structural analysis domain. The structure of this domain and the terminology is imitated in the proposed energy analysis domain. The main

supertypes of the structural entities are also used as an entry point for energy concepts into the IFC hierarchy, such as *'IfcSystem'*, *'IfcGroup'* and *'IfcProduct'*.

- Property sets. Two specific property sets were identified as particularly useful: *'Pset\_DoorCommon'*, *'Pset\_WallCommon'*. They include a property *'IsExternal'* which can be used to identify if walls and doors are external, and therefore if they should be included in the thermal envelope area calculation.
- The entity *'IfcSystem'* is used to represent the ventilation system. The entity *'IfcEnergyConversionDevice'* is used to represent both the sub soil heat exchanger and the heat recovery unit. The instances of these entities are linked to user-defined property sets using the relationship *'IfcRelDefinesByProperties'*. The user-defined property sets contain a single property: efficiency. The two instances of *'IfcEnergyConversionDevice'* can be linked to object type entities using the relationship *'IfcRelDefinesByType'*. Type objects enable the definition of more specific details about objects. The two specific types which are relevant are the *'IfcAirToAirHeatRecoveryType'* for the heat recovery unit, and the *'IfcHeatExchangerType'* for the sub soil heat exchanger. The common property sets describing these object types in the IFC 2x3 TC1 schema are in Table 5.3, and show that none currently describes the efficiency. These property sets are therefore not used by the PassivBIM system. It should be noted that in IFC4 there are some changes to the schema in this area. The entities *'IfcAirToAirHeatRecovery'* and *'IfcHeatExchanger'* are added to the schema. In addition, the property set *'Pset\_AirToAirHeatRecoveryPHistory'* can be applied to the entity *'IfcAirToAirHeatRecovery'* to describe the efficiency with properties such as *'TotalEffectiveness'*.
- The *'IfcShapeRepresentation'* entity and its attributes describe geometry of building elements.

Table 5.2 and Table 5.3 show relevant properties of both IFC entities and property sets. Property sets can be defined using the *'IfcPropertySet'* entity, which can be attached to another IFC entity using the relationship *'IfcRelDefinesByProperties'*. In the IFC documentation, the *'IfcExtendedMaterialProperties'* has an example set of properties intended for energy calculation (viscosity temperature derivative, moisture capacity thermal gradient, thermal conductivity temperature derivative, specific heat

temperature derivative, visible refraction index, solar refraction index and gas pressure). These do not relate to the PHPP concepts identified as required, and consequently they are ignored. The properties in bold in Table 5.2 and Table 5.3 are relevant to PHPP. The majority of the PHPP energy concepts do not exist in the IFC. PHPP concepts could be now simply added to existing entities. However, the entities are deleted in the Ifc2x4 RC3 schema and documented as property sets e.g. '*Pset\_MaterialThermal*'. The other option is to simply update and create new property sets.

The use of property sets has certain benefits and limitations. As they can be custom defined they offer flexibility (Schevers and Drogemuller 2005), and they can be implemented sooner than waiting for the possibility that they may be incorporated into a future release of the IFC. Their main limitation is they are not part of the formal EXPRESS or XML file. In order for property sets to be used, agreement has to be sought between participants exchanging information. The property sets then have to be generated alongside the main IFC file. This attaches a certain amount of risk to their use.

Another argument against simply adding property sets is some of the energy concepts are not just properties, but are activities and groups and should therefore be part of the official IFC schema. For example, the total sensible heat gain is not a simple window property such as the material thickness, but is calculated based on individual gains and so should be a subtype of the IfcGroup entity.

Property sets have also been defined in the past as providing "*valid substitutes to the definition of object/attribute/relationship sets for entities that are not yet completely ready for inclusion in the data model, have not been entirely agreed upon, or for which it has not yet been unequivocally decided where they fit in the data model*" (Bazjanac and Maile 2004). This would indicate that new additions to the IFC schema should be first introduced as property sets. This view is however not shared by the methodology outlined for proposing a new domain for the IFC by Liebich and Wix (1999). If the removal of all the entities in Table 5.2 and subsequent addition as property sets by IFC4 is kept in mind, it further seems the trend is actually the opposite: entities are removed from the schema and reintroduced as property sets. A more recent and simple definition of a property set is a "*collection of free attributes that can be assigned to objects defined within the IFC schema*" (Wix and Liebich 2009). Consequently, the approach of defining all new concepts as property sets will not be taken in this thesis.



**Table 5.2 IFC entities related to the thermal domain.**

IFC Entity	Subtype entity	Properties and data types
<b>IfcMaterialProperties</b>	IfcThermalMaterialProperties	specific heat capacity (IfcSpecificHeatCapacityMeasure), boiling point, freezing point (IfcThermodynamicTemperatureMeasure), thermal conductivity (IfcThermalConductivityMeasure)
	IfcGeneralMaterialProperties	molecular weight (IfcMolecularWeightMeasure), porosity (IfcNormalisedRatioMeasure), mass density (IfcMassDensityMeasure)
	IfcExtendedMaterialProperties	extended properties (IfcProperty), description (IfcText), name (IfcLabel)
<b>IfcPropertySetDefinition</b>	IfcSpaceThermalLoadProperties	applicable value ratio (IfcPositiveRatioMeasure), thermal load source (IfcThermalLoadSourceEnum), property source (IfcPropertySourceEnum), source description (IfcText), minimum value, maximum value (IfcPowerMeasure), thermal load time series values (IfcTimeSeries), user defined thermal load source, user defined property source (IfcLabel)
	IfcEnergyProperties	energy sequence (IfcEnergySequenceEnum), user defined energy sequence (IfcLabel)

**Table 5.3 Property sets containing PHPP relevant properties. Properties in bold are relevant to PHPP.**

PropertySet name	Applicable entities	Properties and data types
<b>Pset_SpaceThermalRequirements</b>	IfcSpace, IfcZone	<b>space temperature max.</b> , space temperature min., space temperature summer max., space temperature summer min., space temperature winter max., space temperature winter min. <b>(IfcThermodynamicTemperatureMeasure)</b> space humidity, space humidity summer, space humidity winter (IfcRatioMeasure), discontinued heating, natural ventilation (IfcBoolean) <b>natural ventilation rate, mechanical ventilation rate (IfcCountMeasure)</b> air conditioning, air conditioning central (IfcBoolean)
<b>Pset_SpaceThermalDesign</b>	IfcSpace	cooling design airflow, heating design airflow (IfcVolumetricFlowRateMeasure) <b>total sensible heat gain, total heat gain, total heat loss (IfcPowerMeasure)</b> , cooling dry bulb, heating dry bulb (IfcThermodynamicTemperatureMeasure), cooling relative humidity, heating relative humidity (IfcPositiveRatioMeasure), <b>ventilation airflow rate, exhaust airflow rate (IfcVolumetricFlowRateMeasure)</b> , ceiling RA plenum (IfcBoolean), boundary area heat loss (IfcHeatFluxDensityMeasure)
<b>Pset_AirToAirHeatRecoveryTypeCommon</b>	IfcAirToAirHeatRecoveryType	HeatTransferTypeEnum (PEnum_AirToAirHeatTransferHeatTransferType), MediaMaterial (IfcMaterial), HasDefrost (IfcBoolean), OperationalTemperatureRange (IfcThermodynamicTemperatureMeasure) PrimaryAirflowRateRange (IfcVolumetricFlowRateMeasure), SecondaryAirflowRateRange (IfcPressureMeasure), Weight (IfcMassMeasure)
<b>Pset_HeatExchangerTypeCommon</b>	IfcHeatExchangerType	Arrangement (IfcPropertyEnumeratedValue), ShellMaterial (IfcMaterial),

Due to the reasons above existing property sets will be used ('Pset\_WallCommon', 'Pset\_DoorCommon') and new property sets will only be defined for existing entities ('IfcSystem' and 'IfcEnergyConversionDevice'). All the other energy concept properties added will be as attributes to the entities which extend the IFC schema. PHPP related property sets could however be a future development. A benefit of this would be that they could be implemented by tools instantly as they would be outside the official schema.

#### 5.4.2 ADDING ENERGY CONCEPTS TO IFC

Now that the existing IFC schema has been evaluated, missing concepts can be added. They will form part of a new data model called the energy analysis domain. A methodology for adding a domain to the IFC has been proposed by Liebich and Wix (1999). It includes describing a set of assertions linked to process models, task descriptions and usage scenarios before a formal model is defined. This is usually handled by a team from the domain that is being developed, as well as a technical team, and so is out of the scope of the thesis. An alternative methodology is proposed: to use the structural analysis domain to formulate the outline of an energy domain, utilising the high level PHPP concepts identified in the previous section. The main reason for using the structural analysis domain is to attempt to maintain consistency in the IFC schema, and use similar vocabulary.

Table 5.4 shows the main structural analysis entities that have been used to create an energy counterpart, and their location in the IFC hierarchy using the supertype entity. There is some deviation from the structural analysis headings, due to the difference in nature of a structural and energy analysis.

**Table 5.4 Existing structural analysis entities in the IFC, and the proposed counterparts for the energy analysis domain**

Ref.	IFC supertype entity	IFC Structural analysis subtype entity	IFC energy analysis subtype entity
(a)	IfcProduct	IfcStructuralItem	IfcEnergyItem
(b)	IfcProduct	IfcStructuralActivity	IfcThermalActivity
(c)	IfcGroup	IfcStructuralLoadGroup IfcStructuralResultGroup	IfcThermalLoadGroup
(d)	IfcSystem	IfcStructuralAnalysisModel	IfcEnergyAnalysisModel
(e)	IfcRelConnects	IfcRelConnectsStructuralMember	IfcRelConnectsZone
(f)	IfcRelConnects	IfcRelConnectsStructuralActivity	IfcRelConnectsThermalActivity
(g)	Entity	IfcStructuralLoadResource	IfcEnergyResource

The different structural and energy items are described below using the reference letter from Table 5.4:

- a) The '*IfcStructuralItem*' entity describes structural members and their connections. The '*IfcEnergyItem*' is added to describe energy items, as they can differ to the building elements described by an IFC file. In PHPP, the external façade is regarded as one element for example, as long as it is made from the same material.
- b) The '*IfcStructuralActivity*' describes actions (forces, displacement) and reactions (supports and deformations). Energy calculations can be described as calculating the heat flow and so instances of heat gain/loss such as the solar gain from a window is proposed to be described by '*IfcThermalActivity*'. The main difference between the organisation of the structural and energy analysis domain is in the '*IfcGroup*' entity.
- c) The '*IfcStructuralLoadGroup*' defines the physical impacts of actions and the '*IfcStructuralResultGroup*' is used to group results of structural analysis calculations. In energy analysis, it could be argued that the physical impacts are the heat losses and gains, which are the results of the energy analysis so only the entity '*IfcThermalLoadGroup*' is proposed. The word '*load*' is chosen instead of '*result*'. This is due to the purpose of the entity being to hold thermal losses and gains. A '*result*' could allude to performance metrics such as carbon dioxide emissions, which is another common building performance metric (De Wilde and Tian 2011).
- d) The '*IfcStructuralAnalysisModel*' describes all the loads and results necessary in the structural analysis model, as well as the analysis type. The energy equivalent '*IfcEnergyAnalysisModel*' describes the analysis type, the energy items, activities and loads that were used to generate the model. All these are included to ensure the reproducibility of the results in the case that there are several different types/instances of energy analysis undertaken.
- e) The entity '*IfcRelConnectsStructuralMember*' defines properties which describe connections between structural members. The energy equivalent connects the ventilation heat loss activity to the zone that is used in its calculations, whilst describing properties necessary for the ventilation heat loss. The properties could be part of a property set in the future, but it is important to connect a zone to the ventilation heat loss as different software

make different assumptions about zones. For example PHPP treats the building as a single zone, whilst IES<VE> models contain most rooms defined as zones, and even virtually split some large zones.

- f) In the structural domain, activities are connected to structural items using the relationship '*IfcRelConnectsStructuralActivity*'. The energy domain equivalent is proposed as '*IfcRelConnectsThermalActivity*', but it could be argued that it is not as necessary. In the structural domain, a load can be applied to any structural element, but in the thermal domain it is obvious that for example, the solar gain is caused by the windows. It is still necessary however, to join individual instances of windows to the specific heat gain they cause.
  
- g) Liebich and Wix (1999) state that there is a downward reference style in the IFC, of which the base is the Resource Layer. Part of the IFC extension as a result involved adding energy concepts to the Resource Layer. An EXPRESS-G diagram of the proposed extension can be found in Appendix A, and a summary is shown in Figure 5.6. Similarly to the '*IfcStructuralLoadResource*' model, the entities in the '*IfcEnergyResource*' model are not subtypes of any IFC entities such as '*IfcRoom*'. In the XML schema they are inherited from the '*ENTITY*' concept. The '*IfcEnergyResource*' data model contains concepts which are used by the higher level entities in the IFC schema. This includes an abstract entity '*IfcThermalLoad*', which is used for storing a calculated annual heat demand, and the boundary conditions for the climate, material and ventilation system.

An EXPRESS-G outline of the hierarchy of the main entities in the proposed extension is in Figure 5.5. It shows that the abstract entity '*IfcThermalActivity*' is specialised to eventually describe individual heat loss and heat gains, and the '*IfcThermalLoadGroup*' is specialised to describe overall heat loss, gain and the annual heat demand.

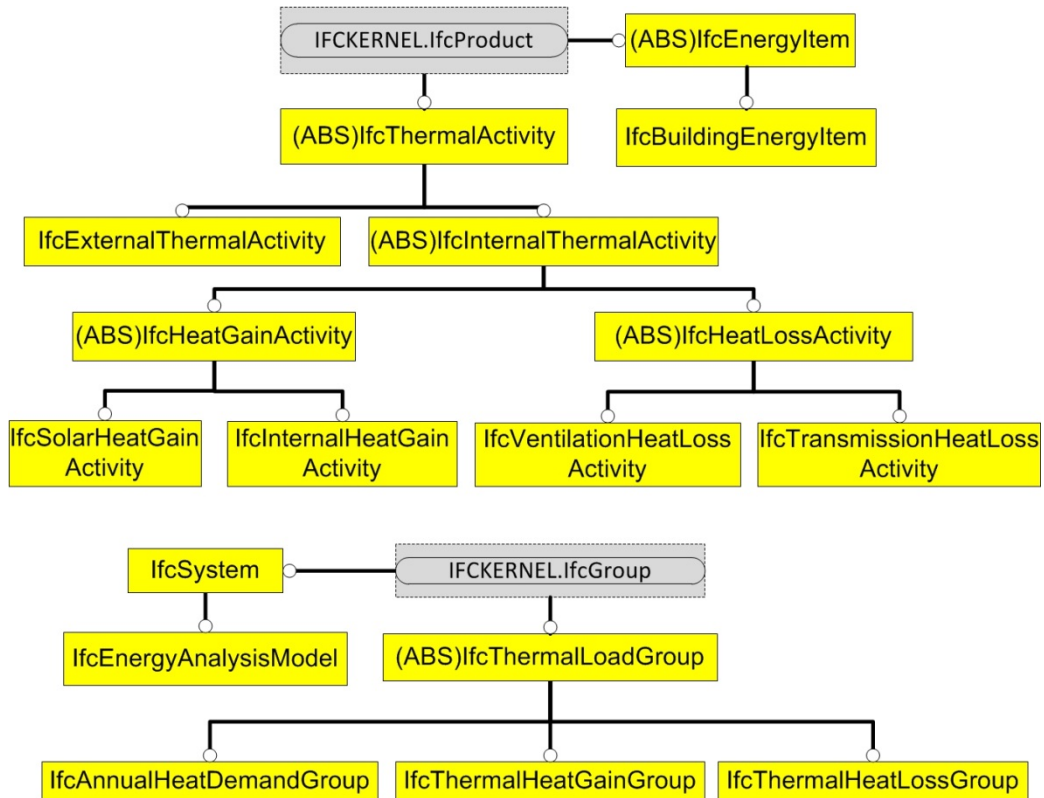


Figure 5.5 An EXPRESS-G diagram of the energy analysis extension structure.

Figure 5.6 is an overview of the proposed '*IfcEnergyResource*'. The concepts are implemented as entities and not '*defined types*', as they all refer to existing '*defined types*'. This same method is used in the Structural Load Resource. Figure 5.6 shows the thermal load can be represented either as an annual figure, or as a figure normalised by area. The actual data is to be stored by two proposed defined types to the '*IfcMeasureResource*' data model: '*IfcEnergyAnnualMeasure*' and '*IfcEnergyAnnualM2Measure*'. The boundary conditions all use existing defined types from the '*IfcMeasureResource*' to physically hold data, such as the '*IfcPositiveRatioMeasure*', '*IfcThermalTransmittanceMeasure*' and '*IfcReal*'. Many other defined types such as these are reused throughout the extension definition.

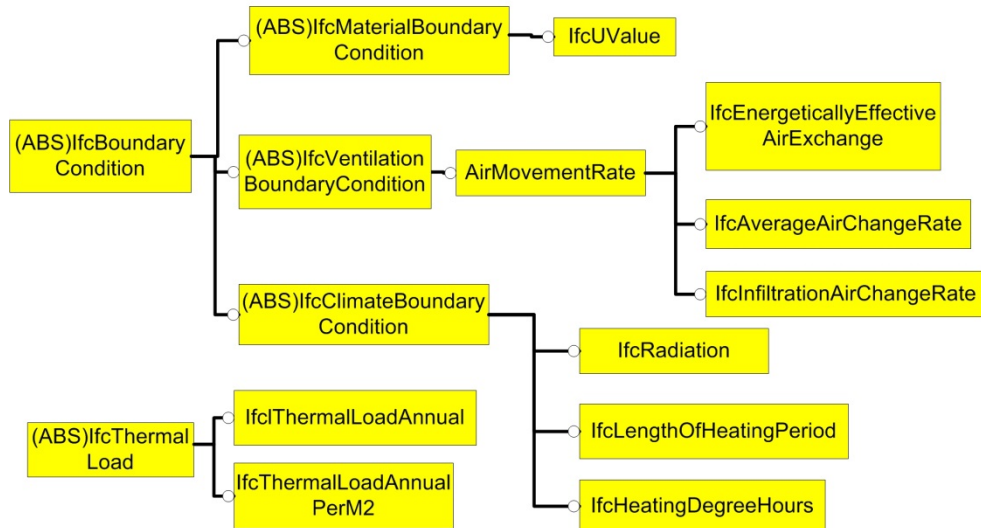


Figure 5.6 An EXPRESS-G diagram of the IfcEnergyResource data model.

In addition to the energy entities being added to the extension, a completely new concept was proposed, based on a similar idea presented by O'Donnell et al. (2011). This new concept is an abstract entity called '*IfcDesignAlternative*', and is shown in Figure 5.7 as an EXPRESS-G diagram. This entity can be substituted by either a climate '*IfcAlternativeClimate*' or a building element description '*IfcAlternativeBuildingElement*'. This allows alternative climates and building elements to be assessed without overriding existing information on an analysis of a design.

Furthermore, a relationship which connects alternative designs to the main energy analysis model has also been proposed called '*IfcRelConnectsDesignAlternative*'. This would connect an original '*IfcEnergyAnalysisModel*' to an alternative building elements and climates. The entity would also store the results of the energy analysis simulation ran with the alternative data. The outcome of this is a mechanism which enables alternative designs to be stored alongside a central model, which could be used by a team to make decisions on the design of a building based on its energy performance. For the prototype, the aim is to establish and evaluate how such an entity could be described.



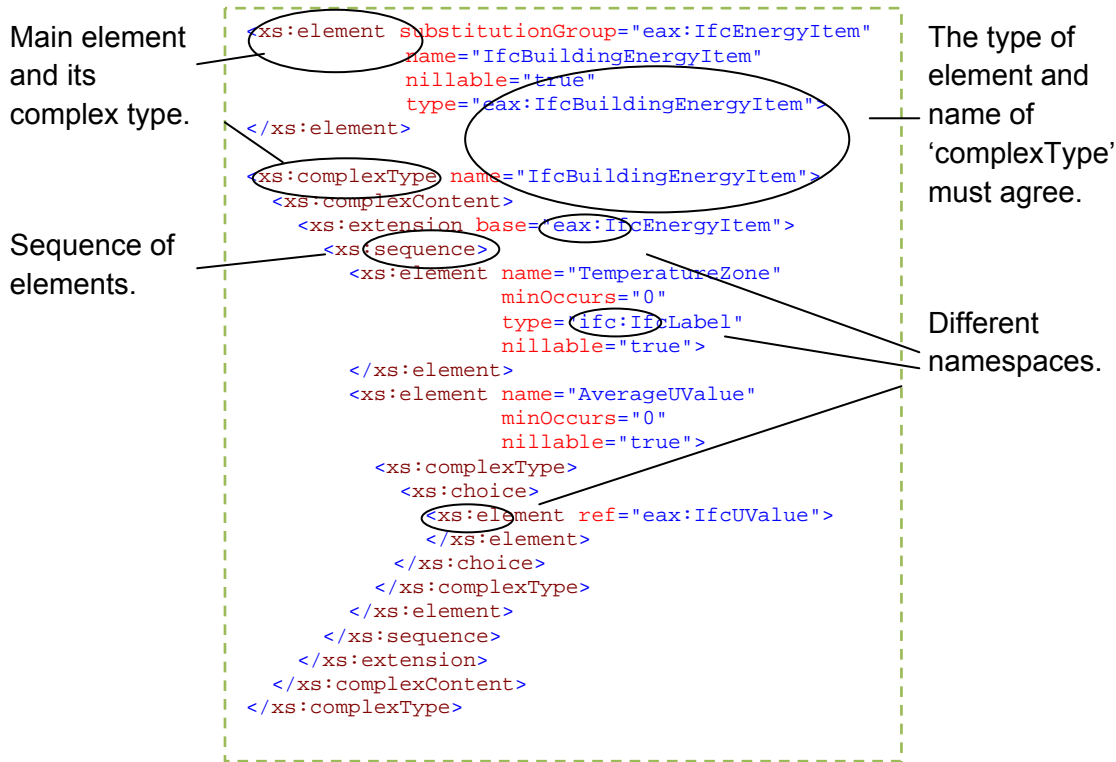
Figure 5.7 An EXPRESS-G diagram of the proposed '*IfcDesignAlternative*' entity.

A detailed EXPRESS-G diagram of the whole extension can be found in Appendix A. The energy analysis extension is formalised in an XSD file called

*'IfcXmlEnergyAnalysisExtension'*. More information on XSD files can be found in section 4.2.4. An example of a complex type representing an IFC entity *'IfcBuildingEnergyItem'* is given in Figure 5.8. First the element is described, and then its type is used to give more information. The element *'IfcBuildingEnergyItem'* has four attributes: a name, a substitution group, a type and given the capability to be nillable. The substitution group is important as it describes the supertype entity that it can take the place of. In this case, if an IFC entity refers to one of its properties being described by an *'IfcEnergyItem'*, in the IFC file the entity that could be used is either *'IfcEnergyItem'* or its subtype, *'IfcBuildingEnergyItem'*. The element type is important, as this is what connects an element to its *'complexType'*. The capability to be nillable is important; as it means this entity can be assigned an explicit null value.

A complex type is then defined for the element. For its details to be associated with an element, it must have the same name as some elements *'type'* attribute. The complex type *'IfcBuildingEnergyItem'* is also described as an extension of the type *'IfcEnergyItem'*. This entitles *'IfcBuildingEnergyItem'* to inherit attributes from it. A sequence of elements is then defined inside the complex type, these are the IFC attributes. For example, the *'IfcBuildingEnergyItem'* has an attribute in the IFC schema called *'TemperatureZone'*, which is filled by the IFC entity *'IfcLabel'*.

There are three different namespaces in the sample schema. The first is *'xs'*, this is used when names of objects defined in the XSD schema on XSD schemas. These include *'element'* and *'complexType'*. This is external to the extension schema and would be referenced to at the top of the XSD file. This mechanism enables a schema to use objects from an external schema. The second is *'ifc'*; this refers to objects such as elements and types which are defined in the original IFC schema. This XSD file is also externally defined, and a reference to it would be in the schema. The third is *'eax'*; the namespace of the energy extension schema.



**Figure 5.8** The simplified description of the entity 'IfcBuildingEnergyItem' in an XSD file.

### 5.5 MsEXCEL TEMPLATE DOCUMENT

The purpose of the MsExcel document is to allow data from PHPP documents to be exported to a file extension that can be read by the PassivBIM Java tool, the XML file type. MsExcel can export data to XML files by importing a XSD schema, mapping its contents to the spreadsheet and then using the MsExcel export functionality. A simplified version of the 'IfcXmlEnergyAnalysisExtension' is used for this process, called 'IfcXmlPHPP'. The simplification is necessary as there are compatibility issues between MsExcel and the IFC XML schema. The key limitations were:

- After importing an XML schema, MsExcel does not display abstract entities and does not allow their mapping. Inherently, this applies to all their subtypes.
- MsExcel is not able to map an element which is part of a <choice> schema construct (Microsoft Corp. 2012).

The simplified schema contains all the extension entities, a simplified version of their supertypes and an object that is the root of all the entities. The roots presence is important as schemas are imported into MsExcel based on a root entity.



'*IfcXmlPhpp*' was then imported into an MsExcel spreadsheet, and will from now be referred to as the Template XML document. Energy concepts from the imported schema were consequently mapped to specific cells in the spreadsheet. A macro was then used to open the target PHPP document, and copy input data into the Template XML document. An XML data file can be exported at this point, which will contain the data in the cells mapped to the simplified schema. This process is sufficient for a prototype as it reuses the extension schema. An alternative for the future would be to eventually incorporate code into the Java tool which would simply open an MsExcel file and extract the data it needs directly.

## 5.6 JAVA TOOL

The Java tool is composed of a range of packages which enable it to read and write XML files that are based on XML schemas, read IFC files and manipulate data. The skeleton of the tool is composed of packages that have been generated automatically from the '*IfcXmlAnalysisEnergyExtension*' schema, and the simplified '*IfcXmlPHPP*'. These enable the tool to read XML from the Template XML document, and to store data in Java classes which relate to the existing and extended IFC schema. The creation of Java classes could be done manually, but it would be time intensive and error prone as the IFC schema is very complex. Therefore, Liquid XML Studio 2011 was used instead to generate the classes. Two packages were handwritten for PassivBIM which use the generated code:

- 'ExtractIfcGeometry', which mainly reads IFC files and then manipulates the areas of building elements so they are in the format necessary for PHPP calculations.
- 'EnergyApp', which reads XML files from Template XML document or takes in user input, calculates the annual energy demand, uses the 'ExtractIfcGeometry' package to overwrite data with geometry from IFC files, and exports XML documents that conform to the extended schema '*IfcXmlAnalysisEnergyExtension*'.

More information about the two packages is given in the sections below.

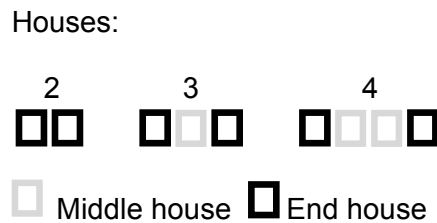
### 5.6.1 ENERGYAPP

An instantiated EnergyApp class holds information about:

- the XML document generated from PHPP,
- the energy analysis model,

- the zone,
- the heat exchangers and the ventilation system,
- the climate (external thermal activity), and
- a list of related alternative designs.

The class main method chooses between using XML, IFC or user input, and calculates the annual heat demand. It can also be used to calculate the average annual heat demand of a ranging number of row houses, by using information about a middle and end house terrace. Figure 5.9 shows examples of configurations of terrace houses. The purpose of this simple algorithm is to show how the design decisions can be informed once the initial energy analysis has been performed. A second simple algorithm to aid design decisions has been implemented, and consists of reversing the annual heat demand Equation C.1 to C.6 in Appendix C. This allows the annual heat demand to be limited to a certain figure, and consequently building parameters can be calculated. Parameters which can be calculated include the area, G-value, and U-value of building elements. More complex versions of such decision informing functions could be implemented in future. At this stage, the implementation is a test which is later presented to experts in the Passivhaus field. This is used to determine if they find this suitable to inform their decision-making.



**Figure 5.9 Example configurations of terraces composed of models of middle and end houses.**

'EnergyApp' also exports data into XML files and straight into PHPP. As the backbone of the Java tool is based on an XML schema, part of the automatically generated code for each IFC class is the function to export it to an XML file. This means that any entity and all the information attached to it through its attributes can be exported in an XML file. This could be eventually held in an XML database. The main limitation of this exportation is that an IFC file will hold all the data about a building in one file, whilst an XML file has to have a root element and it will only describe that element and its attributes. XML files can however be held in an XML

database, which could be online to enable users from different geographical areas to all access the same data.

The process of exporting to PHPP involves two main steps: the data has to be manipulated into a format ready for export, and then an application programming interface (API) transfers the data. As PHPP is an excel-based tool, Apache POI (Apache POI 2012) is used to export data from the PassivBIM Java tool to PHPP. Apache POI is an API for Java tools which enables them to access Microsoft documents. It is composed of many libraries of Java classes, one of which is the 'HSSF' library targeted at MsExcel '97. This library is utilised by PassivBIM as the PHPP spreadsheets are saved in this version. On the Apache POI website, there are guidelines how to use the library so it will not be repeated here. A general overview of the process is: the target PHPP file is read as an input stream, worksheets are referred to in the spreadsheet, cells are identified that will have data transferred to them, cells contents are updated with pre-prepared values and then cells which are reliant on other cells such as total areas are refreshed using an 'evaluator' function.

The cells which are planned to be overwritten in the 'Areas' tab are: building element description (the name of the building element); group number (some are set such as for windows and doors, others are custom); quantity; assigned to group; user determined (user determined area); area (total area of the building element); area group (if more wall types than one added, here their names will be listed). The limitation of PHPP is only three spaces are left for custom walls, so it is a possibility that files have to be checked to make sure they have a maximum of three wall types. The cells which are planned to be overwritten in the 'Windows' tab are: description, quantity, deviation from north, angle of inclination from the horizontal, orientation, width, height, number (from Areas worksheet, links what window voids which wall), installation (left, right, sill and head values entered as 0, as for the moment windows are entered as an individual object and not broken down into parts), and window area.

The data will come from a class which will hold each individual wall type name, its voided area, and a list of all the individual walls which use this wall type. The list will specifically hold the 'step line' number of each wall instance for reference (the line number it is given in a SPF), its orientation, its area without voids taken away, and a list of windows that voids it. The window list holds the name of the window, the width and its height. This class is not part of the IFC schema or the extension; it is there

purely to facilitate the exportation process. The class is automatically instantiated by PassivBIM when an IFC file is read and processed. The tool will use the data to update the wall information in a PHPP document, and then it enters the windows voiding each wall type into the 'Windows' tab so they can be linked to the right walls. This is consistent with the current workflow of PHPP.

### 5.6.2 EXTRACTIFCGEOMETRY

The first part of this section describes how IFC files are read by the 'ExtractIfcGeometry' class. This continues with a brief summary of how IFC entities describing building elements and spaces are adjusted so they are suitable for PHPP calculations. More detailed information can be found in Appendix B.

#### 5.6.2.1 Reading an IFC file

There are a range of tools which can read and process an IFC file, one of which is Open IFC Java Toolbox (Open IFC Tools 2012). This toolbox is composed of Java classes stored in packages, which can be used for processing and visualising IFC files. The two packages used in this project are:

- 'openifctools.openifcjavatoolbox.ifcModel', which contains the 'IfcModel' class which can be used to read and store data from an IFC file and
- 'openifctools.openifcjavatoolbox.ifc2x3tc1', which contains Java classes that store information from the IFC file for all the entities, defined types, enumerations and select types in the IFC 2x3 TC1 schema.

In order to use these packages, the java class 'ExtractIfcGeometry.java' is instantiated by 'EnergyApp'. Then creates the class 'IfcModel', uses it to read an IFC file and stores data using one of the predefined 'IfcModel' functions: 'readStepFile()'.

#### 5.6.2.2 Placement and representation of products

The 'IfcBuildingElement' entity is a subtype of 'IfcProduct', so it inherits the attributes 'ObjectPlacement' and 'Representation'. The representation of a product holds information about the shape of the building element. The object placement relates where that object is located. This can be relative to another objects coordinate system, or given absolutely in the World Coordinate System (WCS). For example, a building element is placed relatively to a building storey. In order to transform a point in 3D space between different coordinate systems, transformation matrices can be used. These are composed of vectors describing rotations and translations. All the

necessary rotation and translation information can be taken from entities related to the placement of a building element.

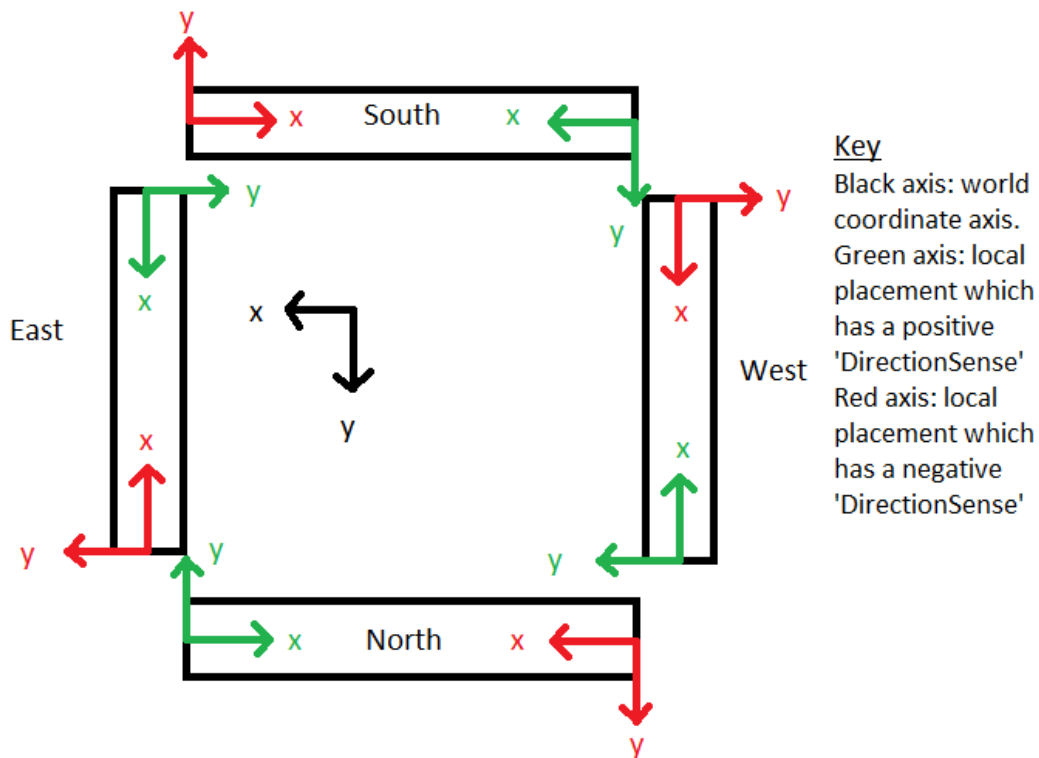
### 5.6.2.3 Processing wall geometry

The IFC can be used to describe two different types of wall type: *'IfcWall'* and *'IfcWallStandardCase'*. This latter allows: “*more intelligent data to be exchanged*” (Wawan Solihin 2010) as the *'IfcWall'* is not associated with as much parametric data. As a result, only the *'IfcWallStandardCase'* is currently supported by *'ExtractingIfcGeometry'*.

The first stage is to distinguish if a wall is external or not. This can be decided using the property set called *'Pset\_WallCommon'*. This property set has an attribute *'IsExternal'* which can be true or false. Walls and property sets are connected using the relationship *'IfcRelDefinesByProperties'*.

The next stage is to characterise the orientation of the wall. The orientation of windows is required by the solar heat gain calculation, but it is difficult to calculate as windows can be described by a plethora of objects. The standard wall is described as a single object that is extruded and possibly voided and clipped. The wall orientation is therefore calculated instead, and then applied to windows which are embedded in it. One convention is assumed for this process after examining several IFC files: wall materials are given from the internal to the external face. The list of wall materials is an attribute of the entity *'IfcMaterialLayerSet'*. This entity itself would be alluded to by an *'IfcMaterialLayerSetUsage'*, which is related to objects using the relationship *'IfcRelAssociatesMaterial'*.

The orientation of a wall can be calculated from its local placement. Figure 5.10 shows a plan view of walls with different orientations, and their possible coordinate systems. The walls face each other with their internal sides. The origin of their coordinate systems will be at one of the ends of a wall. The *'DirectionSense'* of an *'IfcMaterialLayerSet'* entity can hold the value *'positive'* or *'negative'*. It can be used to decide if the y-axis is pointing to the outside or inside of a wall. A unit vector is defined which points from the walls origin to its inner face. It is then translated to the WCS using transformation matrices. As the positive y-axis of the WCS by default points north, the orientation can now be worked out.



**Figure 5.10 A plan view of possible local placements of walls with different orientations.**

In order to extract geometrical data, the shape representation of a wall has to be analysed. The two types which can be processed by *'ExtractIfcGeometry'* are a *'SweptSolid'* and a *'Clipping'*. A *'SweptSolid'* shape can be given by the *'IfcExtrudedAreaSolid'* entity. This has the attribute *'Depth'* (the height of a wall) and *'SweptArea'*. The *'SweptArea'* instance can be the entity *'IfcRectangleProfileDepth'*. This has the attributes *'XDim'* and *'YDim'* which represent the wall length and width respectively.

A *'Clipping'* is a shape which can be said to be initially represented by a *'SweptSolid'* that is then cut by planes. This is to take into account for example the joining of a wall to a roof. In this thesis, the process of clipping starts with the identification of the vertices of the exterior face of the wall. This needs to take into account that the sides of adjoining walls may form part of its front face. Wall connections are described by the relationship *'IfcRelConnectsPathElements'*. The polygon formed by the vertices is then adjusted by an extended version of the Sutherland-Hodgman polygon clipping algorithm (Foley et al. 1996). The thickness of the lowest floor must then be added to the wall face. Finally, the location of the thermal boundary is next taken into consideration. If the thermal envelope ends at the height of the tallest floor, then the wall face has to be cut so any area above the floor height is ignored.

If the thermal boundary is in the roof, the thickness of the roof slabs must be added to the wall face.

#### 5.6.2.4 Processing floor geometry

Floors can be drawn in BIM tools to finish at both the inner or outer face. For a PHPP calculation the floor needs to finish at the outer face, so external walls are relied upon by '*ExtractIfcGeometry*' instead of the floor slab. The details on the connections between walls can be found in the relationship '*IfcRelConnectsPathElements*'. Walls are described by this as either '*RelatedElement*' or '*RelatingElement*', and can join as is depicted by Figure 5.11. They are also given a connection type, which can be represented by the values '*AtStart*' or '*AtEnd*' and relates to the position of the origin of each wall placement in relation to the connection. The vertex needed to describe the extents of the floor is deduced from these details. The first step is the '*RelatingElement*' walls origin has half on the width of the wall added to it. Then if the '*RelatingElement*' wall is '*AtEnd*', the length of the wall can be added onto the adjusted origin. This process is repeated for each connection between two external walls, and the resulting polygons area is the total floor area needed for PHPP.

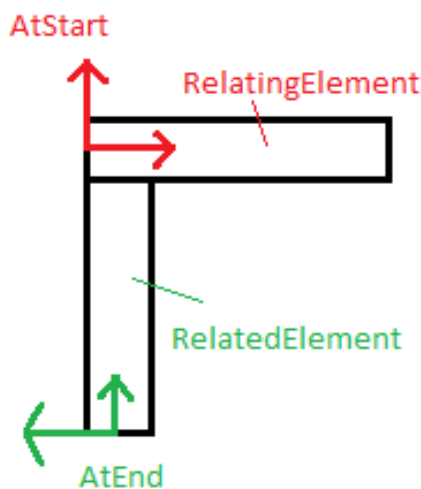


Figure 5.11 L-shaped connection between walls

#### 5.6.2.5 Processing window geometry

The processing of window geometry is twofold. The window must first be classified with an orientation, and then its area is calculated. A window is related to an opening by the relationship '*IfcRelFillsElement*'. An '*IfcOpeningElement*' creates a void in a wall with the relationship '*IfcRelVoidsElement*'. The steps that must be taken to find the orientation of a wall are given in section 5.6.2.3. The two above relationships can be used to determine what wall a window is embedded in, and

consequently what orientation it is. The area of a window is the product of two of *'IfcWindow'* attributes: *'OverallHeight'* and *'OverallWidth'*.

#### **5.6.2.6 Processing door geometry**

Doors can be either external or internal, which is documented in the property set *'Pset\_DoorCommon'*, similarly to the wall in section 5.6.2.3. The area of the external doors can be calculated from the following attributes of each *'IfcDoor'* entity: *'OverallHeight'* and *'OverallWidth'*.

#### **5.6.2.7 Processing roof geometry**

IFC roof geometry is composed of several individual slabs, linked together with the relationship *'IfcRelAggregates'*. Similarly to the wall shape representation, it can be commonly a *'SweptSolid'* or a *'Clipping'*. The prototype currently supports the *'SweptSolid'* type. The area corresponding to a roof in PHPP depends on the location of the thermal boundary. If the thermal envelope ends at the highest floor, then the area of the highest floor is required by PHPP. If the thermal envelope is the roof slabs, then their area is necessary. In this project, two main assumptions are made in order to locate the thermal boundary: (a) the entity *'IfcSpace'* is a thermal area and (b) if a space shares a boundary through the relationship *'IfcRelSpaceBoundary'* with a roof slab, the thermal boundary is in the roof.

If the roof slab area is needed, any overhangs need to be removed as is done in Figure 5.12. The lowest floor is projected onto the plane of the *'IfcExtrudedAreaSolid'* which is related to the roof slab. This is done by finding the intersection of the horizontal vectors located at the floor vertices with the  $z=0$  plane of the *'IfcExtrudedAreaSolid'* coordinate system. The floor edges then cut off the roof overhang using a second adaptation of the Sutherland-Hodgman polygon clipping algorithm (Foley et al. 1996).



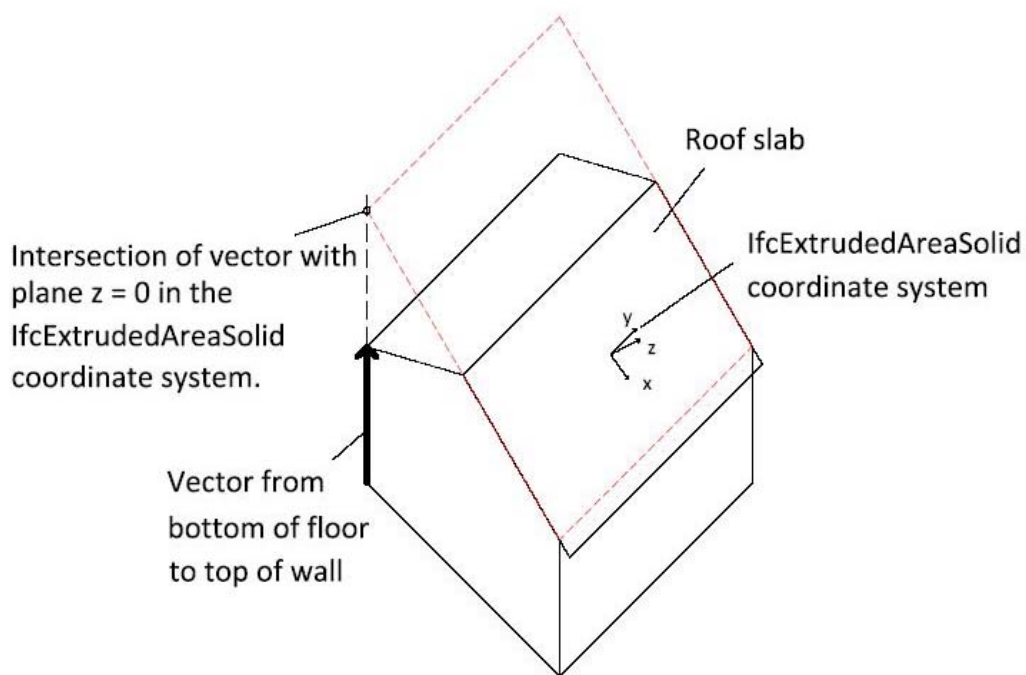


Figure 5.12 The removal of the overhang in a roof slab.

#### 5.6.2.8 Processing TFA

The TFA relies on the *'IfcWindow'* for reveal areas, and *'IfcSpace'* for floor areas. In order to qualify for the TFA, rooms must have a height of over 2m. This is checked automatically by *'ExtractIfcGeometry'*. If a room has a height of 1-2m, half of its floor area can be counted towards the TFA. This is also checked by *'ExtractIfcGeometry'*. Some areas are not allowed at all, for example the stairs. These areas must not be defined by the user in the BIM tool to result in an *'IfcSpace'* being exported. Only a certain percentage of other areas are allowed due to the nature of a space. The ratio of a space being put forward for the TFA can be altered through the *'Description'* attribute of an *'IfcSpace'*. Currently, if the value of this attribute is a decimal figure, the product of that figure and the space area counts towards the TFA. Additionally, eligible window reveals have to have a depth greater than 0.13m, and they must start at the floor height.

*'ExtractIfcGeometry'* can process *'IfcSpace'* entities which have the representation type *'SweptSolid'* or *'Brep'*. For a *'SweptSolid'*, the attributes *'Depth'*, *'XDim'* and *'YDim'* (described in section 5.6.2.3) can be called upon to calculate an area and check the height of a space. A *'Brep'* representation is composed of many faces. These are defined using three or more coordinates. Each face in a *'Brep'* is checked to see if it forms part of the floor of a space, and if the height of the space is above 2m. The floor area calculation needs to be extended in the future so parts of a representation can be eligible for the TFA. Any windows next to spaces now are

identified using the *'IfcRelSpaceBoundary'* relationship, so their reveals can be analysed. The *'IfcWindow'* shape is composed of a plethora of extruded polygons. In order to calculate a reveal, the smallest distance between the inside of a window and the first extruded shape surface needs to be established. This is done by comparing coordinates that are at the beginning and at the end of extruded polygons.

## 5.7 CONCLUSIONS

The data transfer requirements for the PHPP annual heat demand were summarised in Section 5.2. This included a description of the format of the geometry. *PHPP requirements for an energy related data transfer were identified. The issue was raised that data is expected to be in a specific format for the data exchange, which may differ to the way geometry is described in BIM-based files.*

By following the PassivBIM methodology, a tool was designed and implemented which automates the transfer of geometry between BIM tools and PHPP. The PassivBIM system is composed of three main products: an XML Template document, a Java tool and an extended IFC schema. The PassivBIM solution is BIM-tool independent, as it reads IFC and XML files, and can accept user input. Java classes generated from the extended schema form the base of the Java tool. This base was extended with functions such as the ability to process IFC geometry. (Section 5.3). *The proposed system can be used with any IFC compatible BIM tool, and so it can be called software independent. The implementation shows the methodology is viable, and it could now be used to extend the Java tool for other BPS tools and their calculations.*

The IFC schema was analysed for existing energy related concepts, focusing on non-geometrical data. It was found that although some existed in the past, they had been removed from the main schema to become property sets. As property sets are not part of the main schema, there is a possibility that there could be issues with their use. The structural analysis domain in the IFC classes was analysed, and an argument was made for an equivalent energy analysis domain. (Section 5.4.1). *The current IFC schema cannot be used to transfer all the data that is necessary for an energy analysis, and then to hold the results so they could be transferred elsewhere.*

Concepts were added to represent the analysis model, which included the properties of building items needed for energy analysis. Additions were made to the *'IfcResource'* model, as concepts from higher levels of the IFC schema can share lower level concepts, but not vice versa. All the concepts and attributes were added

to the main schema as it was argued in the last chapter that the MVD mechanism reduces problems with the size and complexity of IFC. (Section 5.4.2). *The extension enables an energy analysis to be carried out using the IFC schema. It is not meant to be comprehensive, and more concepts can be added in the future based on consultation with experts in the energy modelling field. It is also possible that as the energy domain in the IFC would expand, some parts of the extension will be more suited to a property set. These areas are possible directions for future work.*

The PassivBIM can also perform decision informing calculations, and calculate the energy demand of a building. Additionally, it then can either output information as XML documents or it can directly export geometry to the PHPP tool. (Section 5.6.1). The Java tool can also calculate the areas of building elements based on an IFC file; and adjust them so they are PHPP compatible. (Section 5.6.2). *The proposed tool supports low energy design, and the certification of Passivhaus buildings. The design informing algorithms could potentially be developed in the future to use sensitivity analysis or optimisation algorithms.*

## Chapter 6 PASSIVBIM VALIDATION AND CASE STUDIES

This chapter introduces the case studies that are used to validate and further develop PassivBIM, and outlines the main steps taken (Section 6.1). Two case studies have been used to validate and further develop PassivBIM: the Hannover Kronsberg terraced buildings (Section 6.2) and the Larch House (Section 6.3).

### 6.1 INTRODUCTION

The purpose of this Chapter is twofold. Firstly, the PassivBIM geometry extraction and annual heat demand calculation are validated using case studies of certified Passivhaus buildings. Secondly, the case studies are used to demonstrate the benefits of using PassivBIM as a decision informing tool. In addition, the use of case studies was important as it allowed the development of the geometry extraction and processing of data of real buildings into a suitable format for PHPP calculations. Both of the case studies are certified as Passivhaus. The following steps were taken:

- The data input files had to be created. This involved modelling the geometry of the case studies using Autodesk Revit, and generating IFC files. It also involved extracting data from PHPP models to XML files.
- The input files are processed by PassivBIM. The energy calculations and geometry extraction are validated using published data and hand calculations.
- The design decision-informing functions are tested. The first case study was a detached Passivhaus, and it was used to show how the building elements can be optimised to facilitate design decisions. The second case study consisted of terraced buildings, and it showcases a function which can be utilised for masterplanning. More details about the individual case studies can be found below.

This is followed by validating the interoperability of PassivBIM with PHPP, and documenting its capability to export to the XML format. These two functions are shown using the Larch House case study.

## 6.2 HANNOVER KRONSBURG

### 6.2.1 OVERVIEW OF CASE STUDY

The first study is based on buildings from an estate in Hannover Kronsberg, Germany. Their performance is validated by measured results published by Schnieders and Hermelink (2006). Figure 6.1 shows the south facades of part of the terraced buildings. The buildings at the end and in the middle of the terrace are called '*Endhaus*' and '*Mittelhaus*' respectively, but in this paper they will be referred to as the end house and middle house.

The purpose of this study is to show that PassivBIM can process: (a) terraced buildings that have party walls, (b) two buildings in a single IFC file, (c) a building with an overhang and (d) a middle and end terrace house to inform design decisions. The case study has a thermal boundary in the roof slabs, as opposed to in the top floor. It was therefore used to develop the Java tool so it can recognise this fact and consequently calculate the right areas of roof slabs, and walls. For example, the whole area of the gable end wall is calculated for the end terrace. If the thermal boundary was above the highest ceiling, only the section of the gable end located below the top of the ceiling would be used in the energy calculations. The roof also had an overhang, so it informed the development of PassivBIM to be able to subtract this from the roof area.



**Figure 6.1 The (a) south and (b) north façades of the terraced buildings in Hannover Kronsberg (Feist et al. 2001)**

Middle house and end house data can be found in a report by Feist et al. (Feist et al. 2001; Feist et al. 2005). Both of the houses have the floor plan called '*Jangster de Lux*' in the reports, but they have different external wall types. Figure 6.2 shows the ground floor, first floor and attic space plans of the Revit models for the middle house. The attic space is mainly used by the building services, so it does not form

part of the TFA. The bedrooms in the first floor occupy the space up to the roof either side of the attic. This can be seen in Figure 6.3, which shows a north to south section view of the middle house, with some dimensions given in millimetres. Most building dimensions are available in floor plans, but some internal dimensions had to be extrapolated.

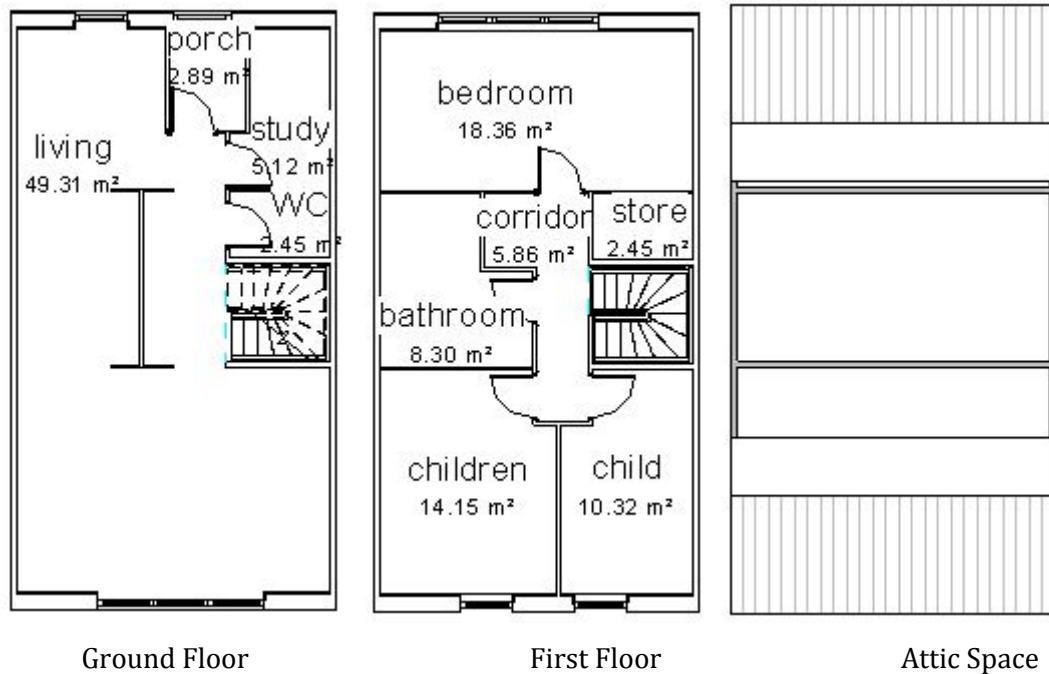


Figure 6.2 Floor plans of a middle house in the Hannover Kronsberg terraces.

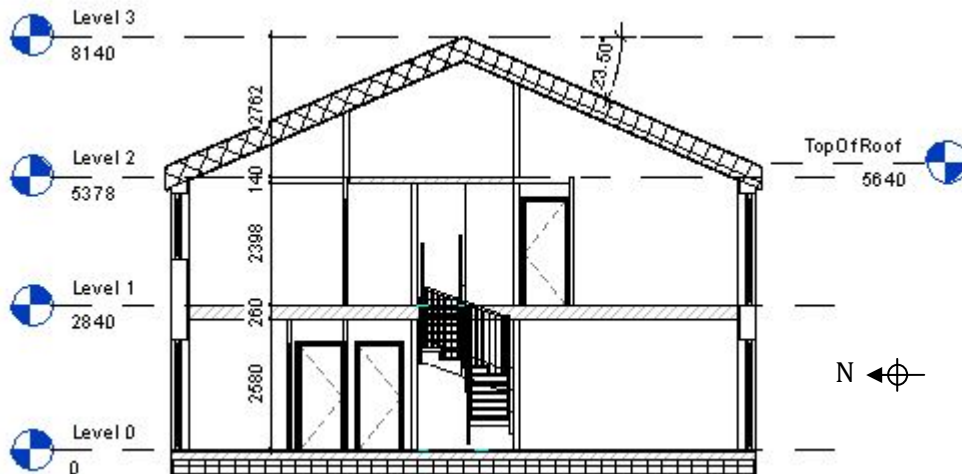


Figure 6.3 North to South section view of the middle house in the Hannover Kronsberg terraces.

The end house has identical floor plans, except either its right or left exterior wall is thicker. The thicknesses of the building elements can be found in Table 6.1. Non-geometric data from the report (Feist et al. 2001 pp.96–97) for the end house and middle house was entered into PassivBIM by hand.

**Table 6.1 Thicknesses of building elements**

Building element	Thickness (mm)
North and south wall of terrace	340
Party walls	120
Gable ends (exposed to air)	575
Ground floor slab	Middle house: 475 End house: 595
Roof	453

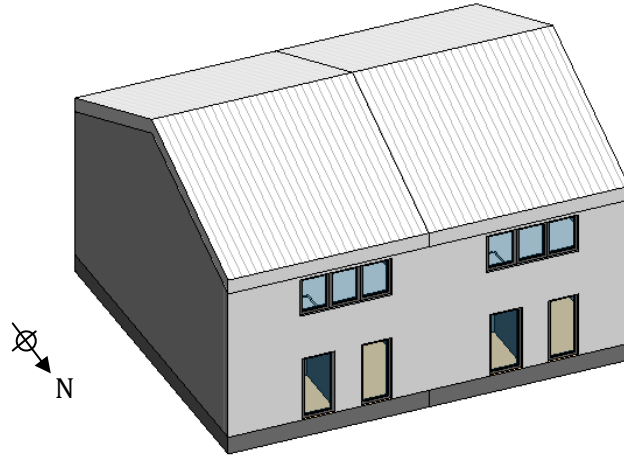
The first part of the study involved creating IFC files representing the middle and end house. There are some practices that have to be followed in order to export an IFC file for PassivBIM processing:

- All external walls must be labelled '*external*' in Revit.
- Party walls must have a '0' in the comment so PassivBIM will not include it as part of the thermal envelope calculation.
- Rooms also have to be defined with the TFA calculation in mind. More specifically, rooms which are not to be included in the TFA need to have a '0' in the comment property, and rooms which only qualify for a certain percentage due to their use need to have that percentage in their comment property.
- Stairs are not to be included, so they should not be selected as a room, or they should be given a '0' in the comment property, taking care that connecting corridors/landings are considered for TFA inclusion.

The second part of the study used an IFC file which describes two end houses side by side, with their party walls in between. The end house model was created for both the left and right end of a terrace in Revit, and the two models were 'linked' and 'exploded' into a single file. Figure 6.4 shows a 3D representation of the Revit model from which IFC files were generated. The non-geometrical data is the same as for the end house model, with the exception of the thermal bridge areas. This data is generally calculated using a dynamic thermal simulation, but as the buildings are identical, the areas were simply doubled.

In the third part of the case study, the PassivBIM Java tool is used to generate a graph that shows the average consumption of all the buildings in a range of terraced

buildings. This process starts with an end house and a middle house model. It then creates scenarios of terraces with different amount of buildings. This is explained in more detail in section 5.6.1. This can be used to assess the impact of surface area to volume ratio (SA/V) on energy demand, which is one of the passive building design concepts (Sodha et al. 1986).



**Figure 6.4 Two Hannover Kronsberg end houses joined together.**

### 6.2.2 RESULTS AND DISCUSSION ON THE VALIDATION PROCESS

The results in this section are divided into two parts. Part (i) describes the geometry extraction process, and the part (ii) describes the annual heat demand results of the various models.

#### (i) Geometry extraction and processing

The IFC files generated from Revit models were all successfully processed. The values of building element areas were confirmed by hand calculations. The amount of error is negligible, and is due to IFC giving a large number of decimal places. The total building element areas are summarised in Table 6.2 to the nearest three decimal places, and the hand verification calculation is shown for the middle house. The wall area is given in two parts for the end house, as two types of walls were identified by the PassivBIM Java tool. This is important for the transmission heat loss calculation, as different types of walls will have different material properties which will affect the transmission of heat. The roof area also confirms that the overhang has been successfully removed, and the wall areas confirm that they have been correctly sorted by the wall type. The windows and external door areas have been removed from wall areas and the gable end has been cut to the right shape by the process described in section 5.6.2.3. The TFA also shows that PassivBIM included the correct rooms and reveals of windows. This included selecting only windows which reach the floor level.

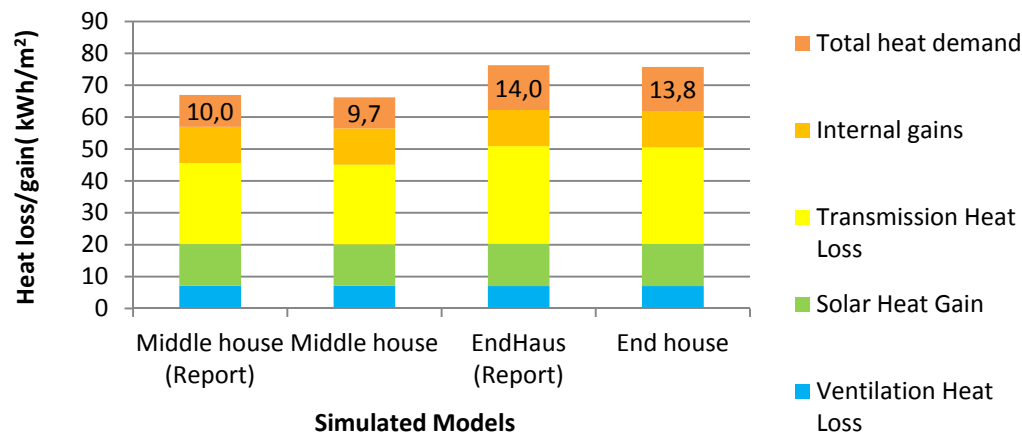


**Table 6.2 Building element areas calculated for various models in Hannover Kronsberg**

Building elements	Middle house (m <sup>2</sup> )	Hand Calculation of Middle House	End house (m <sup>2</sup> )	Two houses (m <sup>2</sup> )
External door	0	-	0	0
Floor slab	71.760	11.5m * 6.240m = 71.76 m <sup>2</sup>	76.993	153.985
North windows	8.598	(2.2m * 1m) + (2.2m * 1.1m) + 3 * (1.3m * 1.02m) = 8.598 m <sup>2</sup>	8.598	17.196
East windows	0	-	0	0
South windows	11.396	3 * (2.2 m * 1.06m) + 2 * (2.2m * 1m) = 11.396 m <sup>2</sup>	11.396	22.792
West windows	0	-	0	0
Exterior Wall N/S (Without windows/doors)	56.321	2 * [ 6.24m * (5.64m+0.475m)] - 19.994 m <sup>2</sup> = 56.321 m <sup>2</sup>	63.492	126.985
Gable end wall	-	-	86.078	172.156
Treated Floor Area	120.267	49.310 m <sup>2</sup> + 2.886 m <sup>2</sup> + 5.122 m <sup>2</sup> + 2.451 m <sup>2</sup> + 18.36 m <sup>2</sup> + 8.300 m <sup>2</sup> + 2.451 m <sup>2</sup> + 10.317 m <sup>2</sup> + 14.150 m <sup>2</sup> + 5.864 m <sup>2</sup> + (3m*0.145m) + (1.1m*0.145m) + 3 * (1.06m * 0.145m) = 120.267 m <sup>2</sup>	120.61	1
Roof	78.250	2 * (6.24 * 6.27) = 78.250 m <sup>2</sup>	83.956	167.912

### (ii) Annual heat demand calculation

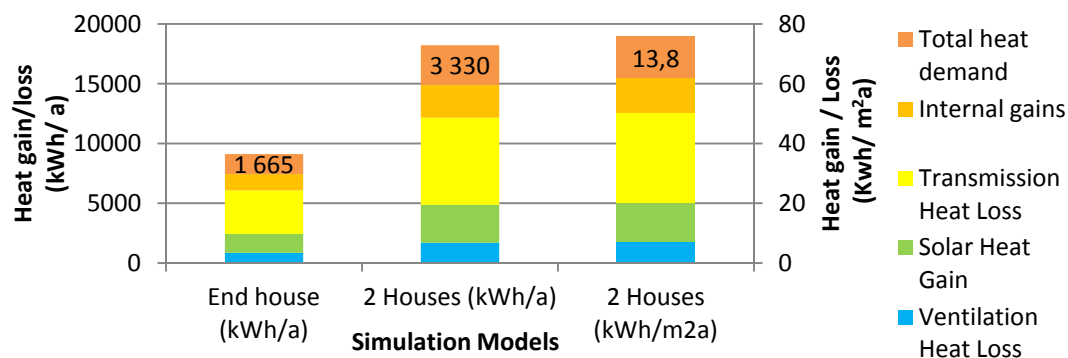
A comparison of values resulting from the annual heat demand calculation published in a report by Feist (2001) and the values calculated by PassivBIM for the middle house and end house can be seen in Figure 6.5. All the values have been normalised by the TFA which is typical in Passivhaus design. There is a high level of agreement between the simulated and published figures. The percentage difference in heat demand between the middle and end house in the report and that calculated by PassivBIM is only 2.56% and 1.3% respectively. The percentage error linked to the middle house and end house is due to differences in the Revit model geometry to the building geometry which would have been used to create the PHPP file for the report by Feist (2001). As the middle house only has two external walls opposed to the three in an end house, it has a smaller heat demand due to a smaller transmission heat loss.



**Figure 6.5 A comparison of the published and PassivBIM calculated heat transfer.**

PassivBIM can also process data for a row of terraced buildings in a single IFC file. Figure 6.6 shows the heat demand for an end house that has not been normalised by the TFA, and two end houses in one IFC file. The heat demand in 'kWh/a' of 2 houses is double that of a single end house, which means the building element areas have been correctly extracted and processed. Also, the heat demand normalised by the TFA to be in 'kWh/m²a' is the same as for a single end house in Figure 6.5, which further confirms the TFA has been correctly exported.

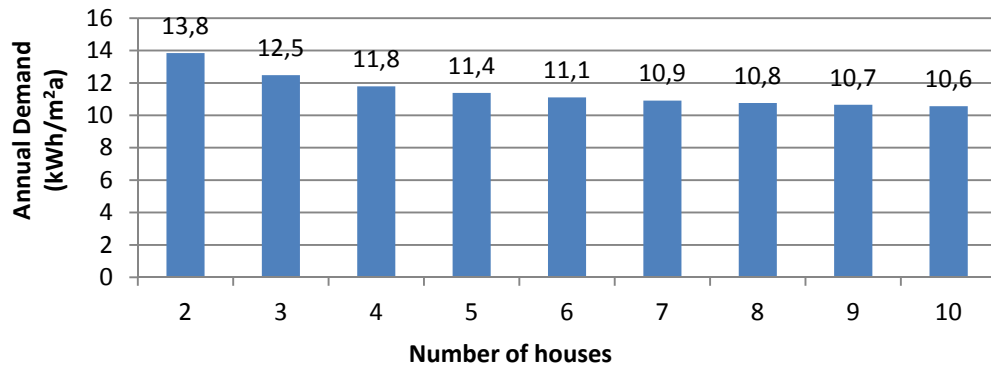
The PassivBIM tool has been validated using a case study whose annual heat demand is supported by measured data. There were some limitations in recreating a model from the data in this report. Some values had to be extrapolated from floor plans as they were not given. There were also inconsistencies between the German and English PHPP files in the reports on the terraced buildings (Feist et al. 2005; Feist et al. 2001).



**Figure 6.6 A single end house compared to two semi-detached buildings in a single IFC file**

### 6.2.3 RESULTS AND DISCUSSION ON THE DECISION INFORMING FUNCTION

The Hannover Kronsberg case study is now used to develop a function that can be used for masterplanning. It uses the data from an end house and middle house of a terrace to calculate different layouts of terraced buildings. Figure 6.7 is an example of terraces created using the Hannover Kronsberg models. It shows that the effectiveness of terracing houses decreases at around 6 houses. This is useful information to a designer who is considering using terraced houses and or semi-detached buildings on a site.



**Figure 6.7 The heat demand of terraces based on middle and end house data.**

Furthermore, this function can be used to test various configurations of terraced buildings. Figure 6.8 shows example configurations of terraced buildings. Figure 6.8 (a) shows four terraces, where one half is composed of two buildings and the other is composed of three buildings. In Figure 6.8 (b) there are just two terraces, and each has five buildings. Figure 6.8 (c) contains 4 terraces, and each contains 2 buildings. Figure 6.9 shows the heat demand of these buildings, where parts (a), (b) and (c) correspond to the terraces in Figure 6.8. This function could now be extended to (1) accept more models, so the terraces in a building could have different layouts, and (2) calculate the effect of the shading from other buildings. The results show that scenario (b) gives the lowest average energy consumption, although it could be argued it is not the most aesthetically pleasing solution. Scenario (c) shows the orientation of a building impacts buildings heat demand.

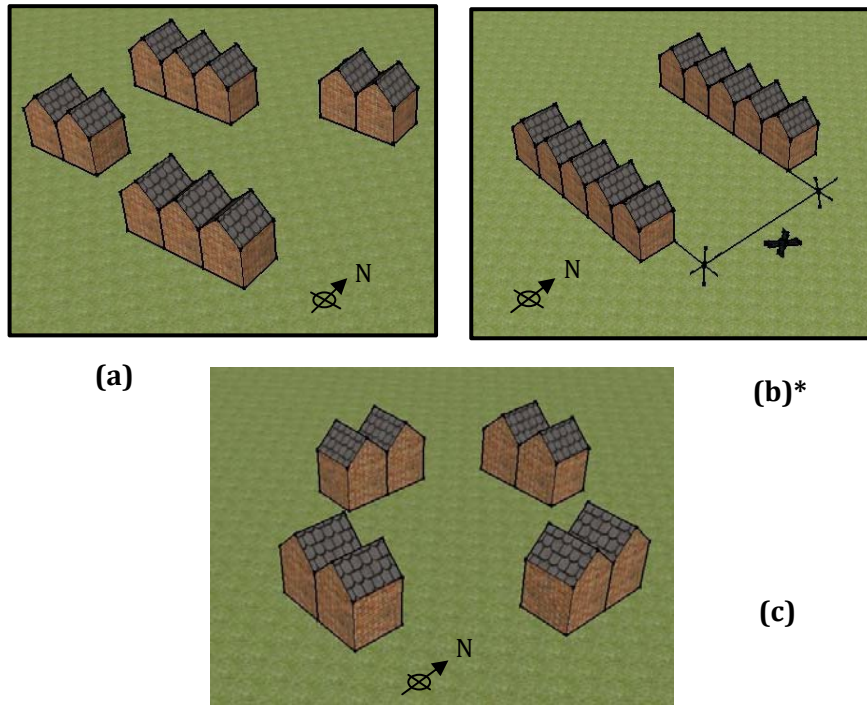
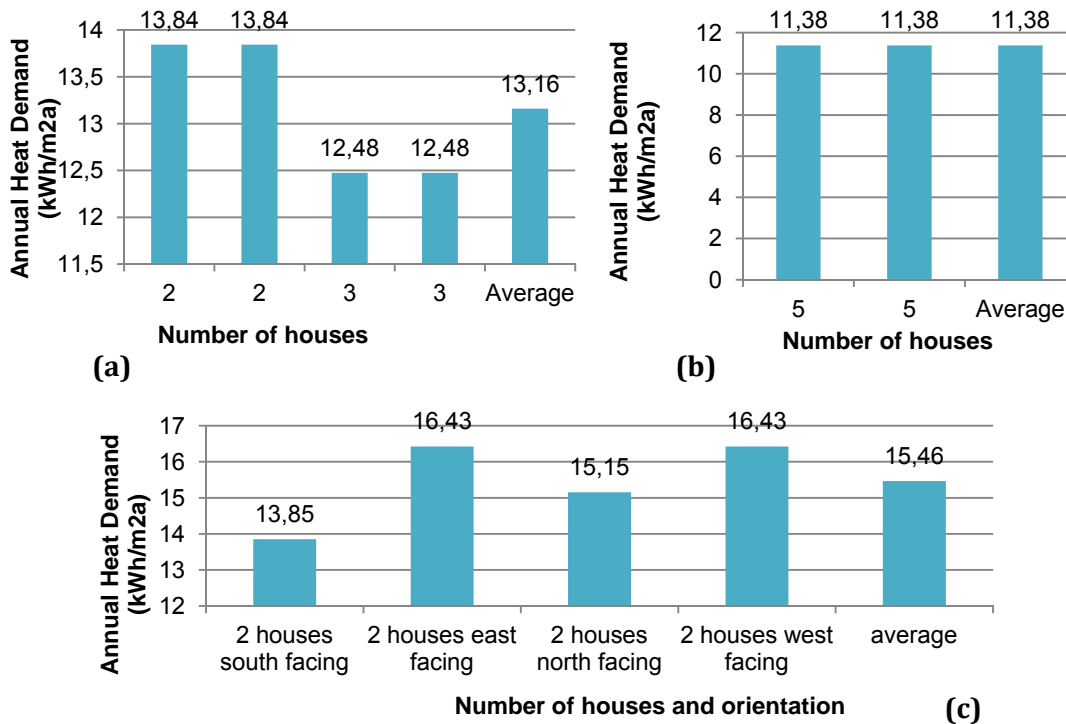


Figure 6.8 Three scenarios (a), (b) and (c) show possible configurations terraced buildings



\*Footnote: The distance 'x' in Figure 6.8(b) could cause buildings to cast shade on each other, especially in the winter. This is not taken into consideration as the 'shading' component of PHPP has not yet been implemented in PassivBIM.

Figure 6.9 The energy consumption of terraced buildings in the configurations from Figure 6.8 (a), (b) and (c).

## 6.3 LARCH HOUSE

### 6.3.1 OVERVIEW OF CASE STUDY

The second study is a Passivhaus building in Ebbw Vale, Wales, called the Larch House. Figure 6.10 shows a picture of this three bedroom detached certified Passivhaus. It was completed in July 2010, but monitored data are not yet available. It is one of the first UK examples of a low cost Passivhaus and it is used as social housing (iPHA 2012b). The building generates electricity using solar thermal and photovoltaic panels. It is also the UK's first zero carbon Passivhaus, which achieved a Level 6 in the CSH. The building is detached, and further validates the geometrical extraction of the Java tool, as it differs geometrically to the Hannover Kronsberg terraced buildings. Unlike in the Hannover Kronsberg case study, the thermal boundary is in the top floor. Consequently, the PassivBIM tool was extended to be able to calculate only the section of wall area which is located below the height of the tallest floor. The case study also involved using the XML Template document as an input device of non-geometrical data, as opposed to user input straight into PassivBIM. The validated models are used to show how design decisions could be informed by limiting the annual heat demand. More specifically, the effect of it has on building element parameters such as U-values and areas can be calculated. This is described in more detail in section 5.6.1. Geometrical data for the building originates from architectural plans so extrapolating internal dimensions is not necessary as for the other case study.



**Figure 6.10 Views of the Larch House, from the (a) South and (b) North (iPHA 2012b)**

Initially only a single Revit and IFC file are necessary for this study, additional information about weather files and non-geometrical data comes from multiple XML files. The north east and south west 3D views of the Revit model are in Figure 6.11, and the floor plans for the ground and first floor are in Figure 6.12. The room names

and areas are used in the TFA calculation. One room is omitted; this is 'Stairs50%' which has an area of 3.085m<sup>2</sup>. Only half of the area counts towards the TFA, as it refers to a cupboard which is not full height.

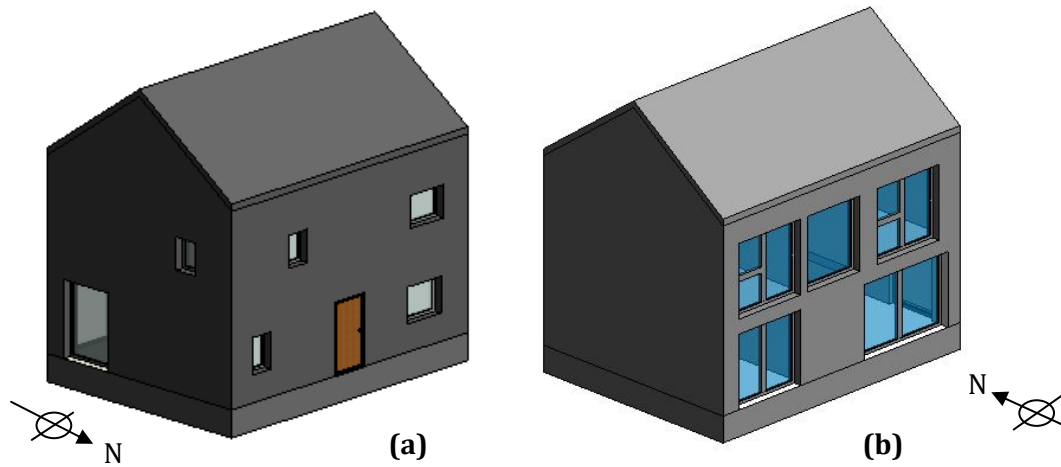


Figure 6.11 3D views of the Revit model of the Larch House from (a) North east and (b) south west.

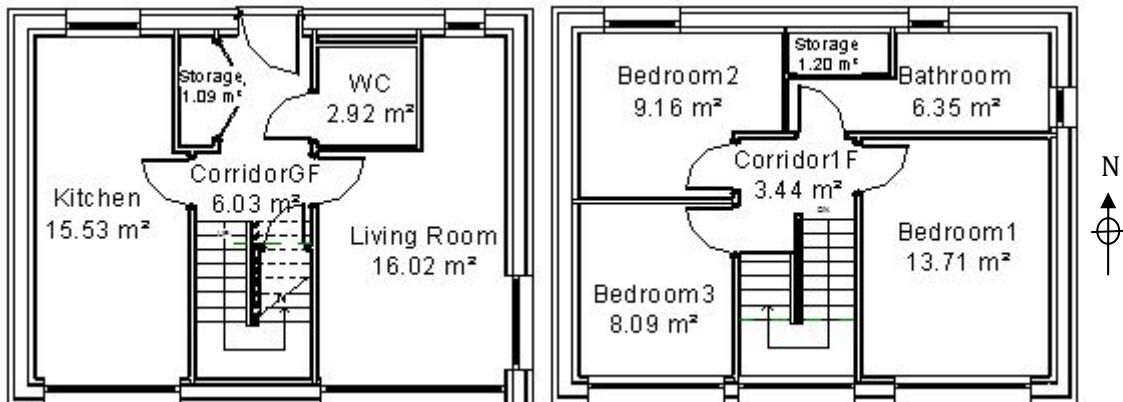
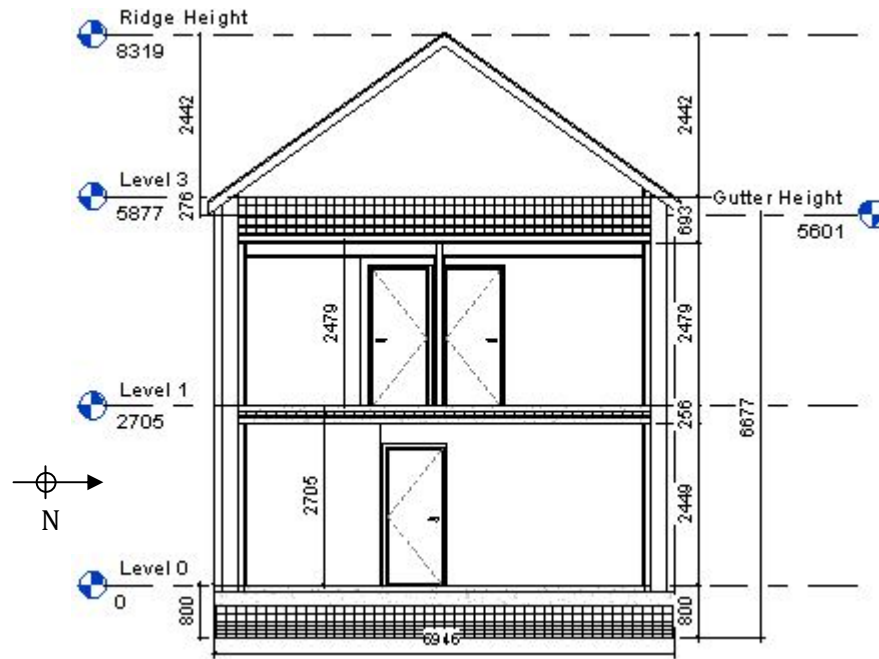


Figure 6.12 Floor plans of ground floor (left) and first floor (right) of the Larch House

The Revit model describes the connections between walls and floors in more detail than the Hannover Kronsberg file. The level of detail can be seen in a north to west section view in Figure 6.13. The dimensions are in millimetres.



**Figure 6.13 Larch House section view by cutting it from North to West**

The construction of the building is given in Table 6.3. The width of the windows and door are not given as they are not part of the main construction, they simply void it.

**Table 6.3 The construction of the Larch House**

Building element	U-Value W/(m <sup>2</sup> K)	Width (mm)
Exterior wall	0.095	473 + rainscreen
Floor	0.076	800
Ceiling above first floor	0.074	578
Windows	0.762	-
External door	0.8	-

The Welsh Larch rainscreen was not modelled in Revit. The cladding is not considered to form part of the thermal envelope as there is a ventilated air space between it and the rest of the wall. It is also only applied to two walls from the base according to the architectural plans. The decision was confirmed by it not being included in the certification PHPP model from the architects.

The external door is certified as Passivhaus, and the windows are triple glazed. All the non-geometrical data used for this case study originates from bere:architects, in the form of a PHPP model. The above can also be found information can also be found online (iPHA 2012b), but other information is not listed so will not be repeated here due to a confidentiality agreement with the client.

The initial model uses an Ebbw Vale climate file to validate the Larch House model against existing data. Two further PHPP models are set up for comparison, placing the same building under a '*London CBD*' climate, and a future climate called '*London CBD2080M50%*'. These climates were generated and validated in a study by McLeod et al. (2012), who also uses the Larch House as a case study. The future climate based on the medium emissions scenario and the year 2080. It is interesting to note that the latitudes of the weather files are similar, with Ebbw Vale having a latitude of 51.76 N and London CBD having a latitude of 51.53 N. Data was extracted from the various PHPP files using the XML Template document, which is shown in Figure 6.14. The right hand side shows the imported simplified energy extension schema. The cells with a pronounced outline are the ones which are mapped to concepts in the simplified schema. The ellipse in the top right is linked to a macro which fills the spreadsheet with data from a PHPP model.



Passive House Planning INPUT TEMPLATE

Annual Heat Demand

SOURCE

Containing folder	C:\Users\Sasa\Dropbox\		
Filename (e.g. test.xls)	LarchHouse.xls		

Fill in filename, containing folder and press here to fill template with annual heat demand data

VERIFICATION (necessary??)

Building Type			
Utilisation Pattern			
Values Used			
Planned Occupancy			

SPECIFIC ANNUAL HEAT DEMAND

Building:	Hwylus Haus		
Building Type/Use	Detached residential house		
Location:	Ebbw Vale		
Interior Temperature (°C)	20		

CLIMATE

Climate:	Gt kWh/a	Ht (d/a)	Radiation HP (kWh/(m <sup>2</sup> a))	Orientation of the Area:
Wales - Ebbw Vale (MN)	74.2644	204.5165	81.81990991	North
			147.7586373	East
			298.0458648	South
			172.7284698	West
			258.8088354	Horizontal

Clear Room Height(m) 2.5

Zone name PHPP Zone

nV<sub>system</sub> (1/h) 0.425773489

nV<sub>Res</sub> (1/h) 0.014884041

cAir (Wh/(m<sup>3</sup>K)) 0.33

XML maps in this workbook:

uos\_Map

- ns4:uos
  - ns4:IbcBuilding
    - ns4:Name
    - ns4:ObjectType
  - ns4:BuildingAddress
    - ns2:IbcPostalAddress
      - href
      - ref
      - proxy
      - edo
      - id
      - path
      - pos
    - ns2:Purpose
    - ns2:Description
    - ns2:UserDefined
    - ns2:InternalLoca
    - ns2:AddressLines
      - ns3:itemType
      - ns3:cType
      - ns3:arraySize

To map elements, drag the elements from the

Options XML Maps...

Verify Map for Export...

Tips for mapping XML

Figure 6.14 A screenshot of the XML Template document.

### 6.3.2 RESULTS AND DISCUSSION ON THE VALIDATION PROCESS

The results are split into two main sections. The geometry extracted from the Larch House model is discussed first (i). This is followed by the results from the annual heat demand calculation performed by PassivBIM (ii).

#### (i) Geometry extraction and processing

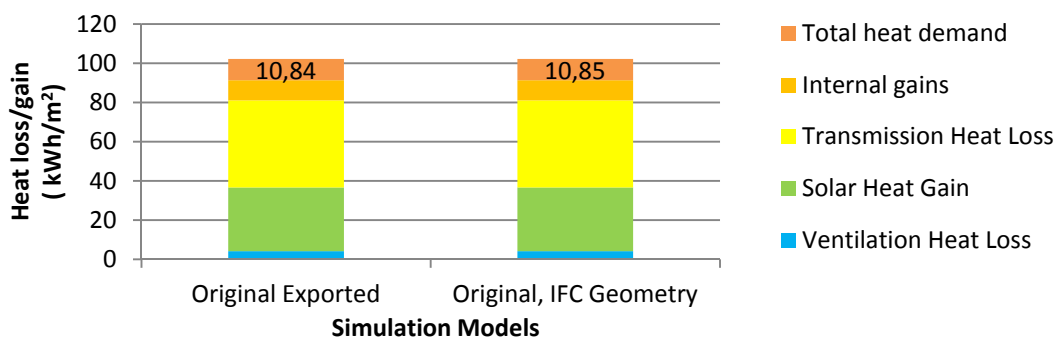
The Larch House geometry has been successfully processed, and the results are summarised in Table 6.4 along with a hand calculation which validates the PassivBIM system. The Larch House processed the building to have a thermal boundary in the ceiling above the first floor, as the floor and roof have the same value for their area. Only half of the floor area of the cupboard underneath the stairs 'Stairs50%' was added to the TFA, which is correct as its height is between 1-2m. The window on the stairs was also identified as not next to a valid room area, and not included in the TFA. The correct window reveals were also extracted from the model, and all the window orientations were identified. The next section will compare the actual heat loss and gain figures calculated using this geometry and that in the PHPP model used for certification.

**Table 6.4 Building element areas calculated for the Larch House**

Building elements	Larch House (m <sup>2</sup> )	Hand calculation of Larch House areas
External door	2.373	1.130m*2.100m =2.373 m <sup>2</sup>
Floor slab	63.875	6.946m*9.196m =63.875 m <sup>2</sup>
North windows	4.070	(0.705m*1.06m) + (0.705m*0.950m) + (1.320m * 0.950m) + (1.320m * 1.060m) =4.070 m <sup>2</sup>
East windows	4.387	(1.645m*2.260m) + (0.705m * 0.950m) =4.387 m <sup>2</sup>
South windows	28.074	(2.260m * 2.384m) + (2.260m * 2.384m) + ( 2.260m * 2.040m) + (2.260m * 2.384m) + (3.230m * 2.260m) = 28.074 m <sup>2</sup>
West windows	0	0 m <sup>2</sup>
Exterior Wall (Without windows/doors)	176.656	[(6.946m*6.677m) + (9.196m * 6.677m) ] * 2 - 2.373 m <sup>2</sup> - 28.074 m <sup>2</sup> - 4.387 m <sup>2</sup> -4.070 m <sup>2</sup> =176.656 m <sup>2</sup>
Treated Floor Area	86.687	3.085 m <sup>2</sup> *0.5 + 15.529 m <sup>2</sup> + 16.021 m <sup>2</sup> + 2.919 m <sup>2</sup> + 1.092 m <sup>2</sup> + 6.029 m <sup>2</sup> + 13.711 m <sup>2</sup> + 6.350 m <sup>2</sup> + 1.199 m <sup>2</sup> + 9.161 m <sup>2</sup> + 8.09 m <sup>2</sup> + 3.443 m <sup>2</sup> + 3*(0.133m*2.384m) + (0.133m*1.645m) + (0.133m * 3.230m) = 86.687 m <sup>2</sup>
Roof	63.875	6.946m*9.196m = 63.875 m <sup>2</sup>

## (ii) Annual heat demand calculation

The Larch House heat demand is closer to published figures than the Hannover Kronsberg buildings. The heat losses and gains between a model with all data exported from the certification PHPP model and the same model overwritten with geometry from an IFC file are shown in Figure 6.15. These models use the Ebbw Vale climate file, and the energy calculation is performed in both cases by PassivBIM.



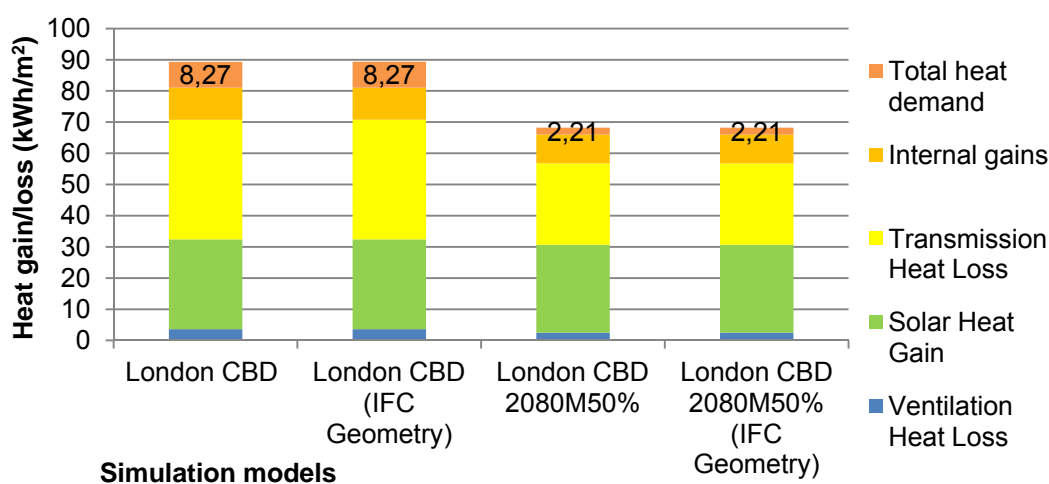
**Figure 6.15** The Larch House model with and without using IFC geometry.

The percentage difference in total heat demand in Figure 6.15 is only 0.1%, which further validates the PassivBIM geometry extraction process. The heat demand for the Larch House in the Ebbw Vale climate is lower than in the study by McLeod et al. (2012a), the Meteoronorm climate file resulted in 13.5kWh/m<sup>2</sup>a. As PHPP can also calculate the annual heat demand using both an annual and monthly method, it is possible that the published figures used the monthly method. The monthly method in the certification PHPP model gives an annual heat demand of 12.9kWh/m<sup>2</sup>a, which is closer to the published figure. The error could also be partly to do with a difference between (a) the geometry description in the PHPP model in McLeod et al. (2012a) and (b) that in the BIM model used to generate the IFC file for PassivBIM.

The data for Figure 6.15 was also used to test the *'IfcDesignAlternative'* entity. The relationship *'IfcRelConnectsDesignAlternative'* connects an energy analysis model entity and a collection of alternative designs. Each *'IfcDesignAlternative'* entity can be described by a collection of loads, and an alternative climate or building element. In order to test the entity, the *'Original Exported'* data model was used as the main *'IfcEnergyAnalysisModel'*. After the data for *'Original, IFC Geometry'* is calculated, the new building elements, their properties and the heat demand results are all connected to the main *'IfcEnergyAnalysisModel'* by the relationship

'*IfcRelConnectsDesignAlternative*'. XML files can then be exported using IFC entities as the roots of the file.

When planning a building, it is useful to verify its performance in a future climate or in an urban heat island. The effects of these two scenarios are presented in Figure 6.16. The '*London CBD*' and '*London CBD 2080M50%*' models use only data extracted from PHPP in the PassivBIM annual heat demand calculation. They are the basis of '*(IFC Geometry)*' models; their geometry is simply overwritten with PassivBIM values calculated from the Larch House IFC file. The percentage difference between the PassivBIM and published (McLeod et al. 2012a) '*London CBD*' and '*London CBD2080M50%*' models is 4.3% and 3.9% respectively. The climate files are the same as used in the report, so any error is associated with aforementioned discrepancies between PHPP models and the calculation method. The significant difference is between models with and without their geometry overwritten with geometry extracted from IFC files, and this difference is low. The percentage difference between the '*London CBD*' and '*London CBD 2080M50%*' with and without using IFC geometry is 0.06% and 0.07% respectively. This is another validation of the PassivBIM geometry extraction process. It is also another opportunity for the '*IfcDesignAlternative*' entity to be used, to hold results for Figure 6.15 and Figure 6.16.



**Figure 6.16** The Larch House in alternative climates, and with/without IFC geometry

### 6.3.3 RESULTS AND DISCUSSION ON THE DECISION INFORMING FUNCTION

Further processing can now be performed on the models to inform design decisions. As the heat demand is a steady state calculation, it can be reversed and used to calculate limits for building elements. For example, the annual heat demand can be set to 15kWh/m<sup>2</sup>a for the London 2080 model, and using the reversed equations explained in Appendix C, the results in Table 6.5 can be calculated.

**Table 6.5 Building elements characteristics before and after annual heat demand is limited to 15kWh/m<sup>2</sup>a for the Larch House**

Building element	Characteristic	Original value	Calculated after limitation
<b>Exterior Wall - Ambient</b>	area (m <sup>2</sup> )	176.629	440.516
<b>Exterior Wall - Ambient</b>	u-value (W/m <sup>2</sup> K)	0.095	0.237
<b>Windows (South)</b>	g-value	0.597	0.886
<b>Windows (South)</b>	area (m <sup>2</sup> )	28.074	is 41.647
<b>Windows(all)</b>	area (m <sup>2</sup> )	36.531	69.454
<b>Windows(all)</b>	u-value (W/m <sup>2</sup> K)	0.762	1.448
<b>Windows(all)</b>	g- value	0.527	1.395

This data could be used to test a buildings resiliency to climate change. For example, the data shows the building is resilient to climate change and will still perform to the Passivhaus standard in in 2080 as:

- The U-values do not have to be as low in the future as they are currently. This means the current building elements will deliver an even lower heat demand under a future climate.
- The area of south oriented windows could be increased by up to 40% and the heat demand would still be below 15kWh/m<sup>2</sup>a under a future climate.

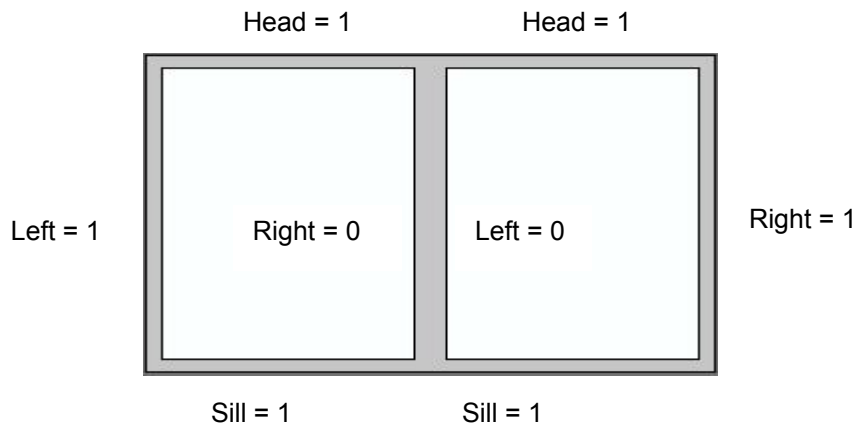
In addition, it can be used to inform design decisions. If a building was not achieving the target 15kWh/m<sup>2</sup>a, its performance could be limited using the PassivBIM tool. The designer could then check which parameters would have to be changed and to what extent in order to achieve the target. This application is simple and as a result has some limitations. For example it is expected that changing the area of the exterior wall would have an impact on the TFA, and increasing the window area will also affect the transmission. Its aim is to show that once the geometrical data is in a PHPP friendly format and is connected to energy calculations, design decisions could be easily influenced. It can be easily extended to provide more complex functions. An example is the shape optimiser proposed by Granadeiro et al. (2013).

#### *6.3.4 RESULTS AND DISCUSSION ON DEVELOPING PASSIVBIM INTEROPERABILITY*

This section is composed of two parts. Initially, the export of geometry from PassivBIM to PHPP is discussed (i). This is followed by a summary on the exportation of data to XML files (ii).

**(i) Exporting geometry to Passive House Planning Package**

The Larch House case study was used to design a proof of concept method of transferring geometric data to PHPP. Screenshots of PHPP after an exportation of building geometry using PassivBIM are shown in Table 6.6 to Table 6.8. All the data were successfully transferred. The building element areas have been loaded into the user-defined cells, and details such as names and group numbers were assigned. The window areas have been subtracted from the relevant building elements, and the cells in the spreadsheet that rely on other cells have been updated, such as the orientation. Table 6.6 and Table 6.7 indicate windows have been treated as being independent, so all the '*installation*' values in Table 6.7 are equal to '1'. It is not taken into account if they are composed of abutted windows. An example of the correct description of an abutted window in the Larch House is shown in Figure 6.17.



**Figure 6.17 The correct installation for a window in the Larch House**

The windows did not need to be to that level of detail for the previous parts of the project, so the windows were not created in enough detail to support describing them panel by panel at this point. However, it is sufficient as a proof of concept.

The information which could be exported in this way is not limited to that shown in Table 6.6 to Table 6.8. If objects which cast shade were included in the IFC file, the input into the '*Shading*' tab in PHPP could also be automated. As the link between BIM modelling and energy simulation matures, and non-geometrical properties such as U-values of building elements and efficiencies of HVAC systems are stored in the BIM model, the potential for automating data input will also increase.

Quantity	Description	Deviation from North	Angle of Inclination from the Horizontal	Orientation	Width	Height	in Area in the Areas worksheet	Nr.
		Degrees	Degrees					
1	Larch89mm:W002:W002:256306	0	90	North	0.705	0.950	Select:	
1	Larch89mm:w004:w004:255623	0	90	North	0.705	1.060	Baric Wall:LarchW	1
1	Larch89mm:w005:w005:255410	0	90	North	1.320	1.060	Baric Wall:LarchW	1
1	Larch89mm:W003:W003:256415	0	90	North	1.320	0.950	Baric Wall:LarchW	1
1	Larch89mm:W006:W006:255743	90	90	East	1.645	2.260	Baric Wall:LarchW	2
1	Larch89mm:W001:W001:256200	90	90	East	0.705	0.950	Baric Wall:LarchW	2
1	Larch89mmLRR:W007/W008:W007/W008	180	90	South	2.384	2.260	Baric Wall:LarchW	3
1	Larch89mmLRR:W007/W008:W007/W008	180	90	South	2.384	2.260	Baric Wall:LarchW	3
1	Larch89mmLR:W011:W011:257635	180	90	South	3.230	2.260	Baric Wall:LarchW	3
1	Larch89mm:W009:W009:259087	180	90	South	2.040	2.260	Baric Wall:LarchW	3
1	Larch89mmLR:W010:W010:257463	180	90	South	2.384	2.260	Baric Wall:LarchW	3

Table 6.6 Window details exported to the Window tab in PHPP

Installation				Ψ-Value		Window Area
Left 1/0	Right 1/0	Sill 1/0	Head 1/0	Ψ <sub>Spacer</sub>	Ψ <sub>Installation</sub>	
				W/(mK)	W/(mK)	m <sup>2</sup>
1	1	1	1			0.7
1	1	1	1			0.7
1	1	1	1			1.4
1	1	1	1			1.3
1	1	1	1			3.7
1	1	1	1			0.7
1	1	1	1			5.4
1	1	1	1			5.4
1	1	1	1			7.3
1	1	1	1			4.6
1	1	1	1			5.4

Table 6.7 Window details exported to the Windows tab in PHPP showing the calculated total area.

12	Basic Wall:LarchWallWest:275403		46.38	Temperature zones "A", "B","P" and "X" may be used. NOT "I"											
13	Basic Wall:LarchWallNorth:275234		57.33	Temperature zones "A", "B","P" and "X" may be used. NOT "I"											
14	Basic Wall:LarchWallEast:275284	X	41.99	Temperature zone "X". Please provide user-defined reduction factor (0 <= 75%											
Total Thermal Envelope													148.07		
WARNING: The building elements are not correctly assigned to the envelope areas. The respective building element must be selected in column 'U'.															
Area Input															
Area Nr.	Building Element Description	Group Nr.	Assigned to Group	Quantity	x	a [m]	x	b [m]	+	User-Determined [m²]	-	User Sub-	Subtraction Window Areas [m²]	) =	Area [m²]
	Treated Floor Area	1	Treated Floor Area	1	x		x		+	86.69	-			) =	86.7
	North Windows	2	North Windows												0.0
	East Windows	3	East Windows												0.0
	South Windows	4	South Windows												0.0
	West Windows	5	West Windows												0.0
	Horizontal Windows	6	Horizontal Windows												0.0
	Exterior Door	7	Exterior Door	1	x		x		+	2.37	-			) =	2.4
1	Basic Wall:LarchWallSouth:275358	8	Exterior Wall - Ambien	1	x		x		+	61.40	-		28.1	) =	33.3
2	Basic Wall:LarchWallWest:275403	12	Basic Wall:LarchWall	1	x		x		+	46.38	-		0.0	) =	46.4
3	Basic Wall:LarchWallNorth:275234	13	Basic Wall:LarchWall	1	x		x		+	61.40	-		4.1	) =	57.3
4	Basic Wall:LarchWallEast:275284	14	Basic Wall:LarchWall	1	x		x		+	46.38	-		4.4	) =	42.0
5					x		x		+		-		0.0	) =	
6					x		x		+		-		0.0	) =	
7					x		x		+		-		0.0	) =	
8					x		x		+		-		0.0	) =	
9					x		x		+		-		0.0	) =	
10					x		x		+		-		0.0	) =	
11	Floor Slab	11	Floor Slab	1	x		x		+	63.88	-		0.0	) =	
12	Roof Slab	10	Roof/Ceiling - Ambient	1	x		x		+	63.88	-		0.0	) =	

Table 6.8 Building element details exported to the Areas tab in PHPP

(ii) Exporting data to XML files

All the IFC entities that are in the extension and in the original IFC schema can be instantiated, filled with data and then exported as XML files. The 'EnergyApp' part of the PassivBIM Java tool mainly stores data in instantiations of the 'IfcEnergyAnalysisModel', 'IfcZone', 'IfcExternalThermalActivity', 'IfcRelConnectsDesignAlternative', 'IfcEnergyConversionDevice', and 'IfcSystem' and 'IfcRelDefinesByProperties'. Most of the other entities describe attributes of these entities, and so XML files of the main entities inherently include them. Therefore, only the exportation of the main entities was tested. A screenshot of the exported 'IfcEnergyAnalysisModel' entity for the Larch House is shown below in Figure 6.18. It has been partly collapsed, as the file is very long due to it describing all the building elements and heat gains and losses.



```

1  <?xml version="1.0" encoding="UTF-8"?>
2  <!--Created by Liquid XML Data Binding Libraries (www.liquid-technologies.com)
3  for BRE Institute of Sustainable Engineering - Cardiff University -->
4  <eax:IfcEnergyAnalysisModel_Nillable xmlns:ifc="http://www.iai-tech.org/ifcXML/
5  xmlns:xs="http://www.w3.org/2001/XMLSchema-instance" xmlns:eax="D:/PhppXml"
6  xmlns:AA="urn:iso.org:standard:10303:part(28):version(2):xmlschema:common">
7    <ifc:GlobalId>emptyemptyemptyempty01</ifc:GlobalId>
8    <ifc:OwnerHistory/>
9    <eax:EnergyItems>
10   <eax:IfcBuildingEnergyItem>
11     <ifc:GlobalId>emptyemptyemptyempty02</ifc:GlobalId>
12     <ifc:OwnerHistory/>
13     <ifc:Name>Building Element Assembly 1</ifc:Name>
14     <ifc:ObjectType>Exterior Wall - Ambient</ifc:ObjectType>
15     <eax:TemperatureZone>A</eax:TemperatureZone>
16     <eax:AverageUValue>
17       <eax:IfcUValue_Nillable>
18         <eax:MaterialUValue>0.0950274450485191</eax:MaterialUValue>
19       </eax:IfcUValue_Nillable>
20     </eax:AverageUValue>
21     <eax:Area>176.628848</eax:Area>
22     <eax:TemperatureFactor>1.0</eax:TemperatureFactor>
23     <eax:GValue>0.0</eax:GValue>
24     <eax:Orientation>North</eax:Orientation>
25   </eax:IfcBuildingEnergyItem>
26   <eax:IfcBuildingEnergyItem>...</eax:IfcBuildingEnergyItem>
42   <eax:IfcBuildingEnergyItem>...</eax:IfcBuildingEnergyItem>
58   <eax:IfcBuildingEnergyItem>...</eax:IfcBuildingEnergyItem>
74   <eax:IfcBuildingEnergyItem>...</eax:IfcBuildingEnergyItem>
90   <eax:IfcBuildingEnergyItem>...</eax:IfcBuildingEnergyItem>
106  <eax:IfcBuildingEnergyItem>...</eax:IfcBuildingEnergyItem>
122  <eax:IfcBuildingEnergyItem>...</eax:IfcBuildingEnergyItem>
138  <eax:IfcBuildingEnergyItem>...</eax:IfcBuildingEnergyItem>
154  <eax:IfcBuildingEnergyItem>...</eax:IfcBuildingEnergyItem>
170  <eax:IfcBuildingEnergyItem>...</eax:IfcBuildingEnergyItem>
186  <eax:IfcBuildingEnergyItem>...</eax:IfcBuildingEnergyItem>
202  <eax:IfcBuildingEnergyItem>...</eax:IfcBuildingEnergyItem>
218  <eax:IfcBuildingEnergyItem>...</eax:IfcBuildingEnergyItem>
234  <eax:IfcBuildingEnergyItem>...</eax:IfcBuildingEnergyItem>
250  <eax:IfcBuildingEnergyItem>...</eax:IfcBuildingEnergyItem>
266  <eax:IfcBuildingEnergyItem>...</eax:IfcBuildingEnergyItem>
282  </eax:EnergyItems>
283  <eax:HasThermalLoads>
284  <eax:IfcThermalHeatLossGroup>...</eax:IfcThermalHeatLossGroup>
312  <eax:IfcThermalHeatGainGroup>...</eax:IfcThermalHeatGainGroup>
379  <eax:IfcThermalHeatLossGroup>...</eax:IfcThermalHeatLossGroup>
578  <eax:IfcThermalHeatGainGroup>...</eax:IfcThermalHeatGainGroup>
597  <eax:IfcThermalHeatLossGroup>...</eax:IfcThermalHeatLossGroup>
607  <eax:IfcThermalHeatGainGroup>...</eax:IfcThermalHeatGainGroup>
624  <eax:IfcAnnualHeatDemandGroup>
625   <ifc:GlobalId>emptyemptyemptyempty37</ifc:GlobalId>
626   <ifc:OwnerHistory/>
627   <ifc:Name>AnnualHeatDemand</ifc:Name>
628   <eax:TotalLoad>
629     <eax:IfcThermalLoadAnnual>
630       <eax:EnergyLoad>940.1490092671543</eax:EnergyLoad>
631     </eax:IfcThermalLoadAnnual>
632   </eax:TotalLoad>
633 </eax:IfcAnnualHeatDemandGroup>
634 </eax:HasThermalLoads>
635 </eax:IfcEnergyAnalysisModel_Nillable>
636

```

Figure 6.18 Screenshot of an XML file of the partly collapsed 'IfcEnergyAnalysisModel'.

## 6.4 CONCLUSIONS

This chapter presents details on two case studies which were used to develop and validate the implementation of PassivBIM. Both of the case studies are existing Passivhaus buildings: one is based on a row of terraced buildings in Hannover Kronsberg and the other is based on the Larch House in Ebbw Vale, Wales. The main conclusions can be found below:

- The Hannover Kronsberg case study was concerned with (a) terraced buildings that have party walls, (b) two buildings described in a single IFC file, (c) a building with an overhang which needs to be removed and (d) how a middle and end terrace house to inform design decisions. There is also measured performance data available for the building, so it is a validated case study. (Section 6.2.1) The aims of the Larch House case study were (a) to test a detached building which has the thermal boundary in the roof, (b) to use a building for which there is more accurate geometrical information available, (c) to use the design alternative entity to link an original model and its results to an alternative model and its results, (d) to test a building under various climates and (e) to develop a simple way to inform design decisions by reversing the main annual heat demand calculation. Larch House BIM model was built according to architectural plans, and the certification PHPP model was used for all other data. (Section 6.3.1) *Different case studies were used to develop and validate a range of processing capabilities of the PassivBIM tool.*
- The Hannover Kronsberg study geometry extraction was compared to a hand calculation, and found to be accurate. The annual heat demand was compared to published figures, and the percentage error ranged between 1.3-2.56%. The error is due to the BIM model which is used to generate an IFC file having different geometry than that used to publish the official figures. Additionally, PassivBIM successfully processed a model containing more than one building. (Section 6.2.2). In addition, a design informing technique was tested, which changes the number of buildings terraced buildings. (Section 6.2.3) *PassivBIM can interpret geometry for one or more terraced buildings. It can also recognise if a thermal boundary is located in the roof.*
- The Larch House case study geometry was checked using a hand calculation. The annual heat demand calculation had a percentage error of

0.1%, which can be considered negligible. When future climate files were used, the percentage error between published figures and PassivBIM calculated heat demand rose to 3.9-4.3%. However, when just the capability of processing IFC files was analysed, the error was only 0.06-0.07%. (Section 6.3.2). The building elements optimisation function was also tested, using a future climate scenario (Section 6.3.3). The output function of the tool to XML file and straight to PHPP was also verified (Section 6.3.4). *PassivBIM can semi-automate data entry, and identify when a building has a thermal boundary in the highest ceiling. It can also output different data to a range of formats, which includes exporting alternative designs. The tool can now be extended to export to the IFC file format. These files could be stored on a central server and the tool could be labelled as a Level 3 BIM tool. It can also be extended to extract shading information, which is also required by the PHPP tool. Furthermore, it can be developed to extract geometry straight from PHPP as opposed to relying on the XML Template Document.*

## Chapter 7 CHALLENGES IN THE IMPLEMENTATION PROCESS

The purpose of this chapter is explained in section 7.1. The chapter then gives details on the issues encountered during the testing of PassivBIM, which are related to the Passivhaus standard (Section 7.2) and the BIM tool used, AutoDesk Revit Architecture (Section 7.3). Some concluding remarks are given in section 7.4.

### 7.1 INTRODUCTION

During the validation of the PassivBIM system, issues were encountered with the Passivhaus standard and Autodesk Revit Architecture 2013's IFC exportation. It is important to discuss the latter, as it was the reason why it was decided against extending PassivBIM to export building data to IFC files. In order to validate the extraction process, existing exportation processes would have to be more reliable. The main issues are briefly outlined in the following sections.

### 7.2 PASSIVHAUS STANDARD RELATED ISSUES

In order for the Passivhaus standard rules to be fully automated, the TFA rules need to be more rigorously defined. For example, the TFA calculation states that the reveal areas of full height windows can be included in the TFA. In reality, this window may be a several centimetres below or above the height of a floor, so a tolerance level needs to be agreed. The English translation on the inclusion of areas of spaces with varying heights also needs clarification. Hopfe and McLeod (2010) state that: "*Count only 50% of the TFA for any room areas > 1m but < 2m high (e.g. habitable lofts with a sloping ceiling)*". This could be interpreted as (a) if one part of a room is sloped and has a height between 1-2m high, only 50% of the whole room floor area is passed to the total TFA or (b) 50% of the area in a section of the room which is 1-2m is passed to the total TFA, and 100% of the area under the section which has a height over 2m is passed to the total TFA. In the German version of the TFA calculation, Feist (2007a) mentions '*Raumteile*', which translates as '*parts by volume*' (Gelbrich and Reinwaldt 1995). This indicates the room area can be split into parts and the appropriate rules applied, and gives a clearer definition.

### 7.3 AUTOCAD REVIT ARCHITECTURE RELATED ISSUES

Three main areas identified as problematic; (i) the '*true north*' was not generated accurately, (ii) objects from IFC files were incorrectly displayed, and (iii) a shape representation of a wall was being exported to an IFC file that has less parametric

information related to it than the standard wall case. These are explained in further detail below.

### (i) True north incorrectly defined

In terms of IFC exportation from Revit, the value for the 'true north' was not accurately exported. This parameter is used to describe the angle of a building from the 'project north' to the North Pole. By default, the 'true north' and the 'project north' are in the positive direction of the y-axis. The direction vector '(0, 1, 0)' should therefore be exported for the 'true north'. The vector exported by Revit was '(2, 0, 1)'. This was further tested with other rotations, to confirm if the first value in the coordinate was always '2', and if the second two values could be used to calculate an angle if they are assumed to be 'x' and 'y' values. The 'z' value is not needed in this scenario, as a house orientation is described in 2D (north, east, south, and west etc.). The results of the angle of the 'true north' to the 'project north' are in Table 7.1, and support the above assumption. This error is one of reasons why the 'true north' value has not been incorporated into PassivBIM to give a more correct orientation of the building at this stage.

**Table 7.1 True North angles calculated from IFC files of the Larch House**

True north angle to project north	Vector in IFC file ( $x_a, y_a, z_a$ )	Angle calculated from y and z of IFC vector ( $\text{Tan}^{-1} [y_a/z_a]$ )	Form of vector which should have been exported ( $x_b, y_b, z_b$ )
0	(2., 6.1230E-17, 1.)	0	(0., 1., 0.)
10	(2.,-0.1736,0.9848)	-9.997	(-0.1736, 0.9848, 0.)
20	(2.,-0.3420,0.9397)	-19.999	(-0.3420,0.9397, 0.)
30	(2.,-0.5000,0.8660)	-30.001	(-0.5000,0.8660, 0.)
40	(2.,-0.6428,0.7660)	-40.002	(-0.6428,0.7660, 0.)
50	(2.,-0.7660,0.6428)	-49.998	(-0.7660,0.6428, 0.)
60	(2.,-0.8660,0.5000)	-59.999	(-0.8660,0.5000, 0.)
70	(2.,-0.9397,0.3420)	-70.001	(-0.9397,0.3420, 0.)
80	(2.,-0.9848,0.1736)	-80.002	(-0.9848,0.1736, 0.)
90	(2.,-1.,-5.4056E-14)	90	(-1.,0., 0.)

### (ii) Objects incorrectly displayed

Revit generated IFC files of the Larch House were also imported back into Revit to test 'roundtrip' interoperability. This purpose of investigating this is to determine if this BIM tool could be used to validate IFC files created by PassivBIM. Roundtrip testing involves both the exportation and importation of an IFC file by the same BIM tool, so if there are any issues the roundtrip test cannot indicate from which process the error originates from. In order to determine which process issues were

connected to, each Revit generated IFC file was also opened in an IFC viewer. If problems are identified to be occurring consistently in both IFC viewing tools, the error can be said to be due to the exportation process.

The IFC viewer used was the '*demo viewer*' from the Open IFC Toolkit project (whose Java classes are used to read IFC files in the '*EnergyApp*' class in PassivBIM). The 3D view of the Larch House after Revit reads the IFC file is shown in Figure 7.1(a), and the same file imported into the '*demo viewer*' application is in Figure 7.1(b). In the Revit version, the most noticeable problems are windows have lost transparency and the walls are not cut accurately where they join the roof. Figure 7.1(b) also showed the tops of walls are cut incorrectly. This would suggest that there is an issue with the way wall and roof joins are described in the IFC file. It is key to note at this point that the IFC file was used in Chapter 6, and the geometrical description of the walls was checked manually and found to be correct. Thus, it seems that the problem may not be with the IFC file itself, but with both the importation capabilities of the IFC '*demo viewer*' and Revit. In terms of the windows, in Figure 7.1(b), the windows were displayed correctly as transparent, but apart from in the south wall they were not voiding the walls and consequently cannot be seen. As the issues highlighted so far by Revit and the '*demo viewer*' are inconsistent, it seems that the problems could be due to the exportation process, but a more extensive study would have to be undertaken to confirm this.

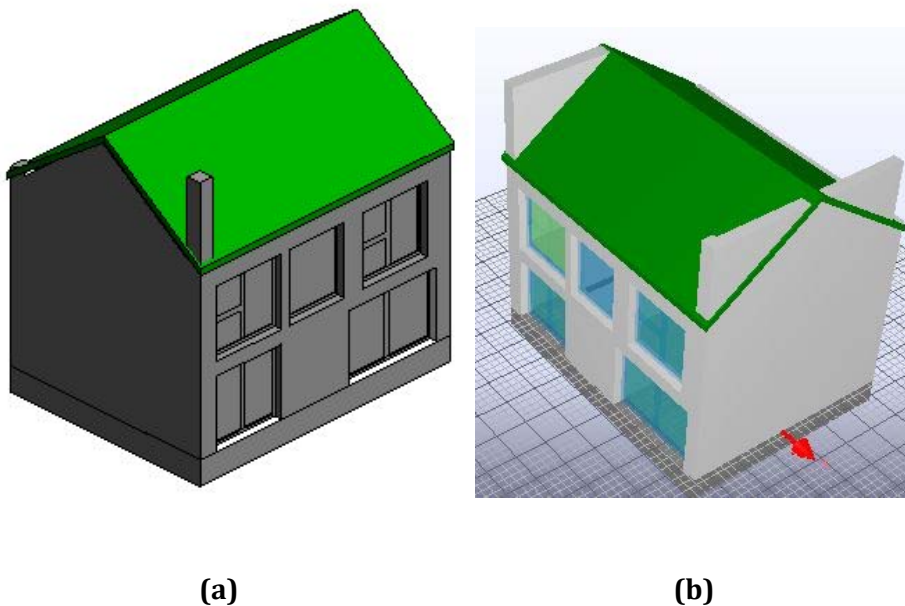
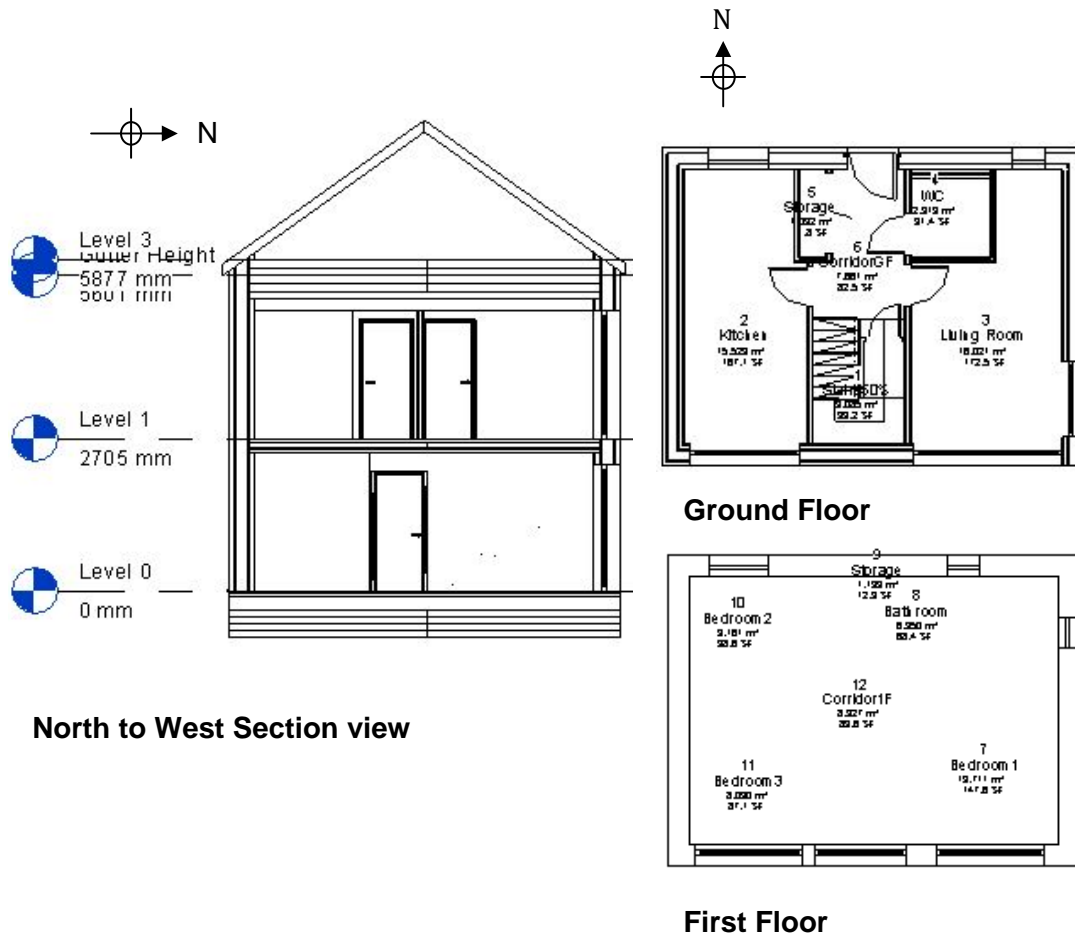


Figure 7.1 The Larch House 3D views in (a) Revit and (b) the demo viewer.



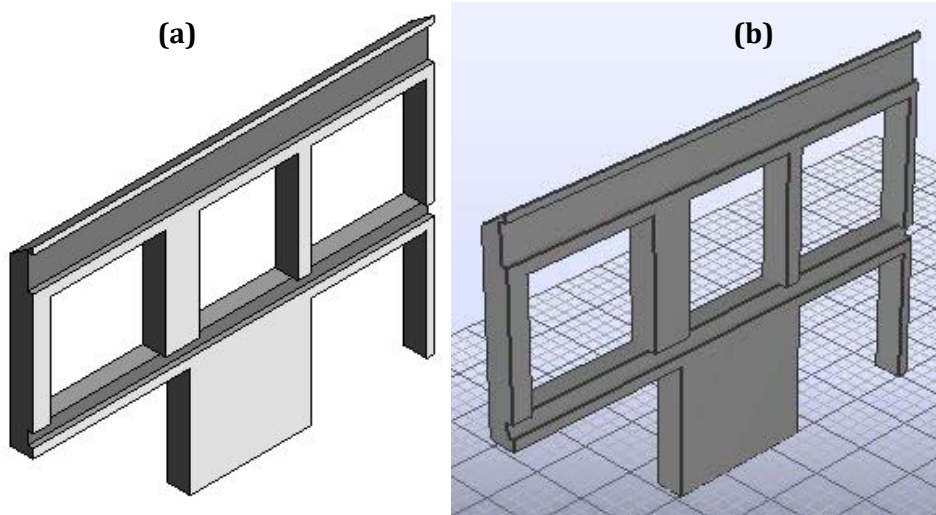
**Figure 7.2 The Larch House ground and first floor plans and north to west section view after importing a Revit generated IFC file back into Revit.**

In order to consider the situation in more detail, the Larch House floor plans and the North to South section view in Figure 7.2 was examined. Revit displays the ground floor room areas and the data related to the construction of building elements correctly. It is less successful in demonstrating their connections, the stairs and it completely fails to describe the first floor room areas. The wall to floor intersection does not show the two top layers of the floor removed by the walls. The description of the window has also suffered a severe loss of information; the plan views of the windows do not look similar, yet they are all composed of a single frame and three panes of glass.

As mentioned in section 5.6.2, the geometry extraction process of PassivBIM was designed which cuts walls with planes so the gable end can be used in external surface area calculations. The planes and initial wall geometry are all taken from the Larch House IFC file. The resulting cut shape was checked with hand calculations and the results were found to be correct, as were the room areas. This seems to further indicate that the issues lie within the importation capability of Revit. As a result, the PassivBIM prototype was not developed to export IFC files in this thesis.

**(iii) IfcWallStandardCase and IfcWall shape representations**

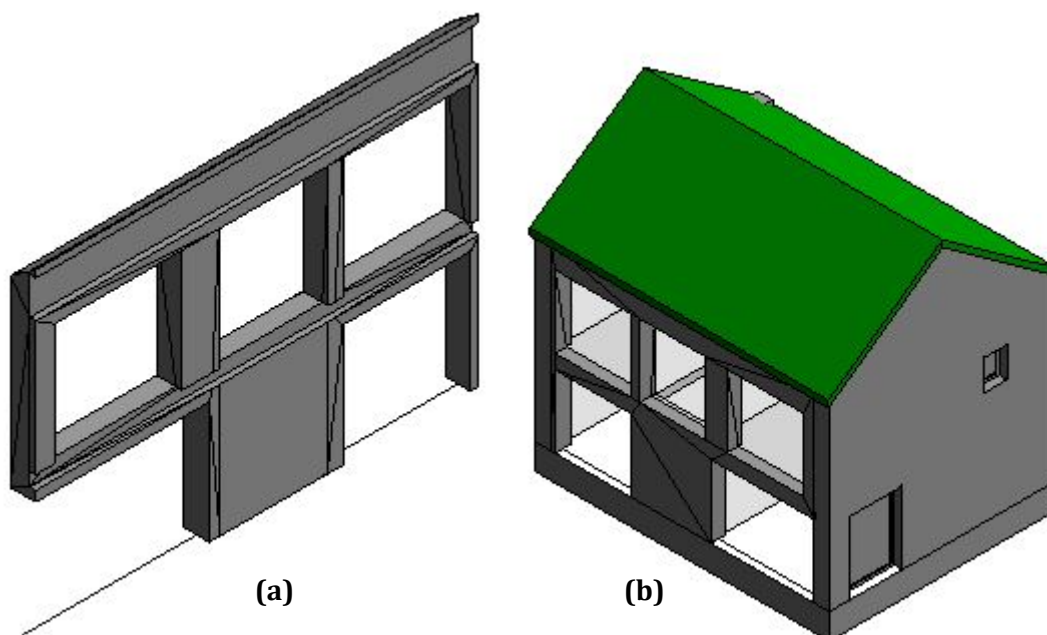
Another limitation arose when windows were inserted into a wall at the floor height on the second floor. In Figure 7.3, the inside face of the south wall of the Larch House is shown voided by floors and windows in (a) Revit and (b) the demo viewer. The three windows on the first floor are inserted at the first floor base height. The Revit and demo viewer representation of the wall is similar, however there is a problem with the IFC entity which describes the shape. When the full building model is exported to an IFC file the south wall is described with the shape representation '*IfcWall*'. This representation is not linked to as much parametric information as its subtype '*IfcWallStandardCase*'. For example, it is not related to the material layer set entity, which is required by PassivBIM for the reasoning on wall orientation.



**Figure 7.3 The Larch House south wall when windows are 0mm above floor level in (a) Revit and (b) demo viewer.**

The '*IfcWall*' representation is also incorrectly displayed by Revit, once the IFC file is imported back into Revit. Figure 7.4 demonstrates how Revit has portrayed the south wall of the Larch House as (a) just the south wall and (b) the effect on the building in the 3D view. The south wall interior and exterior faces have been split into segments. The faces are not being merged in the way that is shown by the demo viewer version in Figure 7.3 (b). The possible reasons for this are twofold. Firstly, Revit may be simply showing all the faces which describe an '*IfcWall*' shape representation, listed in the file using a '*Brep*' representation. Secondly, IFC files can store data to many decimal places, and if the separate shapes are described with negligible difference between them, Revit may not be able to merge them seamlessly. In order to determine which reason is valid, a more thorough understanding of how Revit reads and processes IFC geometry is necessary.

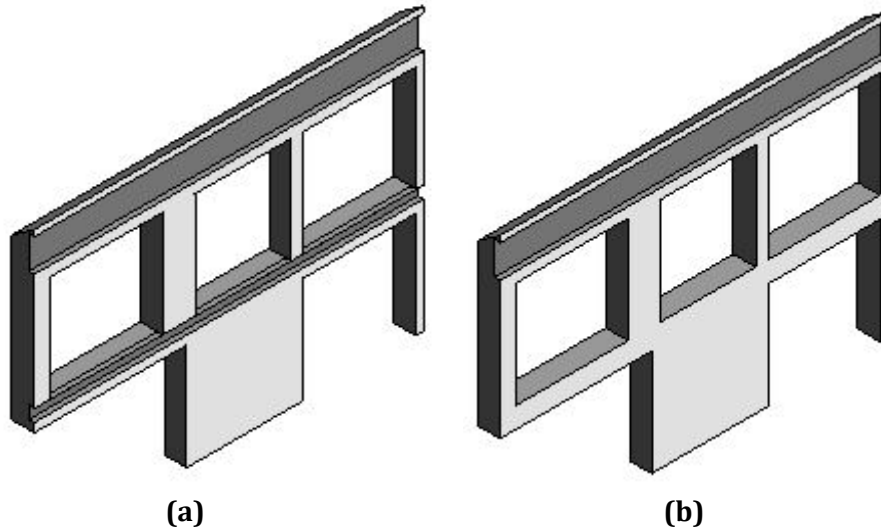




**Figure 7.4** The effect of the '*IfcWall*' being generated by Revit for the south wall for the Larch House. Part (a) is the inside of the wall and (b) is the whole building.

Two situations were found to export the Larch House south wall as an '*IfcWallStandardCase*' instead of an '*IfcWall*'. Figure 7.5(a) is an image of the south wall in Revit, but the three windows on the first floor are now 1mm above the first floor base height. The visual change is almost negligible, but the wall is now related to more parametric information. Figure 7.5(b) is a 3D view of the Larch House where the first floor boundary has been edited so it does not void the wall at the connection. This is a more contraversial solution, as it means the connection cannot be detailed between the floor and wall. Consequently, the first situation was implemented in the Larch House case study.

According to the online IFC schema documentation an '*IfcWallStandardCase*' describes walls that "have a non-changing thickness along the wall path and where the thickness parameter can be fully described by a material layer set" (Liebich et al. 2007) and an '*IfcWall*' is "used for all other occurrences of wall, particularly for walls with changing thickness along the wall path (e.g. polygonal walls), or walls with a non-rectangular cross sections (e.g. L-shaped retaining walls), and walls having an extrusion axis that is unequal to the global z-axis of the project (i.e. non-vertical walls)" (Liebich et al. 2007). By moving the windows and unjoining the floor from the wall the south wall has not (a) changed its thickness, (b) changed the cross section to not be rectangular, and (c) become non-vertical. The solutions have both simply removed the two voids being located next to each other. Arguably, the correct exportation of the south wall should be an '*IfcWallStandardCase*'.



**Figure 7.5** The Larch House south wall when (a) windows inserted on the first floor are 1mm above floor level and (b) when the first floor boundary is changed to lie inside the wall.

#### 7.4 CONCLUSIONS

A range of challenges were identified with Revit's capability to export wall geometry to an IFC file, and then to import the file back. Issues of the nature described in this chapter have to be solved before the IFC can be used to provide seamless interoperability. These problems are also part of the reason why IFC files were not considered as a suitable output format for the PassivBIM tool at this stage. It is key to note at this point that it seems in most cases the fault is with the BIM tool, and not the IFC schema. Problems with Revit's importation process are confirmed with the walls being incorrectly graphically displayed in Revit, whilst being correctly displayed in the demo viewer.

More research would have to be done to confirm the extent of the problems, but this line of research was not continued as it is outside the scope of the thesis. *Developing the IFC is not the only challenge to be addressed when aiming for seamless interoperability. There are still many challenges being faced with exporting and importing IFC files by software vendors which need to be solved. Resolving them will directly benefit PassivBIM and other similar efforts.*

## Chapter 8 USABILITY TESTING

The proceeding chapter summarised the validation of the PassivBIM system based on real life case studies. This chapter continues to analyse the system, but from the user's perspective. This chapter begins with a short introduction to usability testing (Section 8.1). This is followed by a discussion on the procedure taken to test PassivBIM (Section 8.2). The results of the testing are then presented (Section 8.3), and some conclusions are drawn on the usability of PassivBIM (Section 8.4).

### 8.1 INTRODUCTION

Designing a system which is useful to its target user is part of the '*human-centred design*' approach. The definition of human-centred design is "*an approach to interactive systems development that aims to make systems usable and useful by focusing on the users, their needs and requirements, and by applying human factors/ergonomics, and usability knowledge and techniques*" (ISO 2010 p.vi). User-centred evaluation (or usability testing) has been stated as fundamental to the human-centred design process (ISO 2010), and can be done at any point of an interactive systems lifecycle. If performed at the early design stage of a tools lifecycle, it is less costly than at the later stages. A usability test can also be used to inform future versions of a system. These are the main reasons why a usability test was undertaken in this thesis.

There are many definitions of usability. Nielson (2012) simply states that it "*assesses how easy interfaces are to use*". A similar definition is that it "*is concerned with making systems easy to learn and easy to use*" (Preece et al. 1994 p.14). Quesenbury (2001) argues that usability should not be reduced to determining if a user interface is easy to use. Instead, it should be evaluated to see if it is effective, efficient, engaging, error tolerant, and easy to learn. The components of usability are generally claimed to be: learnability, efficiency, memorability, errors, and satisfaction (Nielson 1993; Holzinger 2005). In addition, there is a definition published as part of an ISO standard. This defines usability as the "*extent to which a system, product or service can be used by specified users to achieve specified goals with effectiveness, efficiency and satisfaction in a specified context of use*" (ISO 2010 p.3).

Studies on usability tests have been undertaken in a range of fields such as medical and health care informatics (Bastien 2010), testing cleaning appliances (Sauer et al. 2010), testing web-based applications (Faulkner 2003), and website design (Torrente et al. 2013; Nielson 2012). Usability testing can be done at different stages

of software design. Quesenbery (2008) explains that exploratory research and benchmark metrics are undertaken early in a project. Diagnostic evaluation can then be completed during the design stage, and summative testing is performed at the end of a project.

## 8.2 PASSIVBIM USABILITY TESTING PROCEDURE

Usability testing can be evaluated using different methods and techniques. It has been separated into two main methods by Holzinger (2005): inspection methods and test methods. This is in agreement with the ISO standard 9241-210:2010 (ISO 2010). The standard outlines that there are two main approaches to usability testing: user-based testing and inspection-based evaluation.

The inspection-based approach can be done before or instead of a user-based test. It relies on usability experts (or evaluators) to evaluate a system, and has been labelled as simpler and quicker than the user-based approach. If carried out before user-based testing, it can make it more cost-effective. Holzinger (2005) describes the three main techniques used for an inspection-based method as heuristic evaluation, cognitive walkthrough and action analysis. The inspection-based method has been labelled as unsuitable for novel interfaces (ISO 2010).

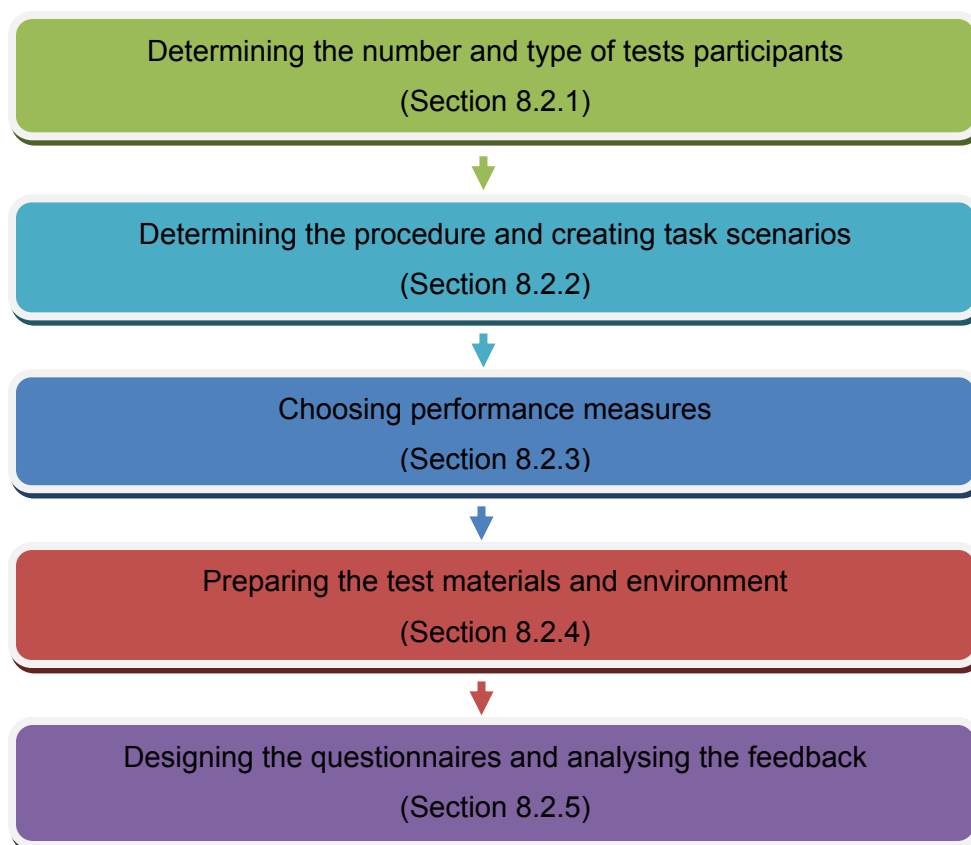
Consequently, inspection-based usability testing is undesirable for the PassivBIM system, as non-experts on sustainable design would not be able to give feedback on the design informing functions, or volunteer information on what could be added to the system to improve the process of design.

The user-based testing can be done at any point in the design stage. It relies on the participation of potential users of the system (Holzinger 2005; ISO 2010). It has been postulated that this method of testing is fundamental, and indispensable (Holzinger 2005 p.73). Holzinger (2005) describes the main techniques as thinking aloud, field observation and questionnaires. The ISO standard articulates that in user-based testing, users can be presented with either design concepts in a visual representation such as a sketch or diagram, or be presented with a working prototype. The feedback received from this type of testing will denote the designs '*acceptability*'.

The PassivBIM prototype does not have an interface at this stage, so the user-based testing of the system based on sketches is a suitable usability testing method. The concept of the prototype can be presented to target users in the form of a mock-up interface, along with some ideas for decision-informing features. The purpose of

this is to determine its acceptability and identify the user's wish list for useful future developments. A user-based test is therefore most suitable for the testing of the system. A mock-up can be described as a low fidelity prototype. The fidelity of a prototype varies from low to high depending on the software stage of development. It has been discussed by Sauer (2010) that in general, having a low fidelity does not produce inferior results. However, they do concede that more studies would have to be undertaken on prototype fidelity to be able to draw a conclusive statement.

In a review paper, Bastien (2010) argues that even though the field of usability testing is well documented, there are still many questions to answer. A similar view is shared by Jacko (2012), who outlines that even the simple question of how many participants should be in a usability study is still open for debate. These questions have to be addressed whilst designing a user test. There are several steps that can be taken in the design of a usability test (Bastien 2010). Consequently, the main steps in creating a user test for PassivBIM can be found in Figure 8.1.



**Figure 8.1 The main steps in creating the PassivBIM usability test**

### *8.2.1 THE SELECTION OF PARTICIPANTS*

The number of participants recommended to be used in usability testing varies. In general, five to eight participants are deemed as sufficient, with five being perceived

as the general rule of thumb (Dumas and Fox 2012; Nielsen 2012; Faulkner 2003). It has been argued that on occasion larger samples are needed to identify usability problems (Faulkner 2003; Spool and Schroeder 2001). Spool and Schroeder (2001) conducted a test using 49 people and four websites, in which they conclude that five participants only found 35% of the problems. Nielsen (2012) concedes that there are some exceptions to the five participant rule. These are (a) when quantitative tests are being run that are concerned with statistics rather than insights into issues, at least 20 participants are necessary, (b) card sorting requires at least 15 participants and (c) eyetracking should have at least 39 participants. However, he argues that five users are still sufficient in other cases, based on results from 38 case studies performed by the Neilson Norman Group. Importance is also placed by Nielsen on (2012) iteratively testing software throughout the software lifecycle, as opposed to a single large scale test.

As the developers of the PassivBIM system are interested in insights about the system, it was decided that six participants are sufficient in order to confirm the validity of the conceptual design. If a working prototype was being tested, a larger participation would be considered in order to make sure that the final product was of the utmost quality.

The selection of participants can depend on several factors, such as “*competence, attitude, state and personality*” (Struck 2012 p.108). They have also been separated as ‘*expert*’ and ‘*novice*’ (Faulkner 2003 p.380; Sauer et al. 2010). Using the latter terminology, 5 of the participants are experts in the field of Passivhaus design as they are accredited CEPH designers, and one is a novice. The novice is a leading architect, and as PassivBIM is also aimed at architects that may not be Passivhaus designers, their view is still valid.

The area of innovation is the use and possible integration of BIM and Passivhaus tools. It is therefore important to establish the level of BIM use of the participants. They cannot be simple sorted into ‘*experts*’ and ‘*novice*’, as there is no BIM ‘*accreditation*’. According to Hopfe et al. (2005), participants can also be categorised as: innovators, early adopters and conservative. Table 8.1 provides the definition of these categories in terms of BIM use. Consequently, the six participants of the survey can be categorised as two innovators, two early adopters, and two conservatives.

**Table 8.1 The different categories of BIM users.**

Category	BIM adoption
<b>Innovator</b>	Develops BIM tools/BIM compatible tools.
<b>Early Adopter</b>	Uses BIM regularly, and is aware of new BIM tools and standards.
<b>Conservative</b>	Uses BIM occasionally.
-	Does not use BIM at all.

### 8.2.2 THE DETERMINATION OF THE PROCEDURE AND THE CREATION OF TASK SCENARIOS

As discussed in section 8.2, the most suitable usability method is user-based testing 'questionnaire'. The specific approach consists of first presenting PassivBIM to the participant, and then directing them to a questionnaire they can fill in. During the presentation, sketches of conceptual designs for the tool will be shown to the participants. The participants do not carry out any tasks using PassivBIM, but they are shown how the system would be used on two real world case studies. The names of the buildings were made anonymous so as not to detract attention from the point of the case studies, as each had a specific purpose:

- Case study 1 related to the Larch House study from section 6.3. It showed a scenario where PHPP files and BIM-generated IFC files were used as input. Additionally, an alternative PHPP model which used a future climate file was included as input. The presentation showed typical results, and how the design optimiser functions could be used to inform design decisions (window size, building element U-values and area to volume ratio). Some possible outputs were then proposed.
- Case study 2 related to the Hannover Kronsberg study from section 6.2. It showed a scenario where a building has party walls. The input consisted of BIM-generated IFC files, user input of non-geometrical data and alternative PHPP and IFC models. The purpose of the alternative models is to be able to compare two sets of results side by side in the results part of the prototype. This section also presented a function which could be used for masterplanning.

After the presentation, the participants had the opportunity to complete a survey. Ozok (2012) outlines that the benefits of using a survey include it is cheaper to implement than organising experiments for users to attend, and it allows the

collection of data on users' satisfaction, ideas, opinions and evaluations of a system. The main limitations include the issues with validity and reliability as (a) it is impossible to measure to what extent participant responses are objective, and (b) there is an assumption that the perception of scale is similar in the respondents (for example their perception of *'likely'* or *'important'*).

The survey was available online, and was completed anonymously. These enabled participants to feel more at ease to leave both positive and negative remarks. In this way, the feedback is objectively given due to the evaluator being removed from the situation. It also avoids to a certain extent the results being influenced by the experience of the evaluator, which has been argued as influential to the results (Dumas and Fox 2012). The survey results will be recorded using an online tool called *'SurveyMonkey'* (SurveyMonkey 2013). The procedure to use this tool consists of: (a) creating a survey, (b) a web link is generated for the survey which can be sent to participants, and (c) once participants reply the results can be viewed on the website once the survey creator logs in. The results can then be exported to various formats.

### *8.2.3 THE CHOICE OF PERFORMANCE MEASURES*

Performance measures can often be used to identify usability problems. Examples of usability measures are given as time to finish a task, time spent recovering from errors, number of wrong icon choices, observations of frustrations, of confusion and satisfaction (Bastien 2010). However, these types of performance measures are not suitable for the usability test of a prototype sketch. The performance measures used instead originate from the ISO definition of usability: effectiveness, efficiency and satisfaction. These can be defined as the following:

- Effectiveness: *"accuracy and completeness with which users achieve specified goals"* (ISO 2010 p.2).
- Efficiency: *"resources expended in relation to the accuracy and completeness with which users achieve goals"* (ISO 2010 p.2).
- Satisfaction: *"freedom from discomfort and positive attitudes towards the use of the product"* (ISO 2010 p.3).



#### 8.2.4 THE PREPARATION OF THE TEST MATERIALS AND OF THE TEST ENVIRONMENT

The test material included a Microsoft PowerPoint presentation, a survey and a participant information sheet. A copy of these can be found in Appendix E, F and G respectively.

The environment of a usability test can either be in a laboratory, or the test can be done remotely. It has been agreed that remote testing provides data which is of the same standard as that produced from a usability lab (Dumas and Fox 2012; Bastien 2010; Tullis et al. 2002). There are a number of benefits to testing remotely, which include (Dumas and Fox 2012):

- Participants can easily come from a range of geographic locations.
- The chance of the participants volunteering is higher as there is no travelling involved.
- The testing may be considered more realistic as the participants are working in familiar surroundings, so they will feel more at ease.
- A usability lab is not necessary.

Due to these reasons, remote testing was used for the usability testing.

There are two main types of remote testing: synchronous where the participant and the moderator are in direct contact throughout the testing, or asynchronous where the participants work without guidance from a moderator. The two approaches have different strengths and weaknesses. It is key to note that Tullis et al. (2002) discovered that comments made by the participants of a remote test can be so rich that they can replace direct observation to a certain degree.

As a result, a combination of both has been used for this usability test. The presentation was given synchronously, as it presented the opportunity for any questions to be answered about the interface and the systems internal workings. The asynchronous method was used for the survey. It can be completed at the convenience of the participants, it has space for comments and it can be completed once they have had time to think about the presentation.

#### 8.2.5 THE DESIGN AND ANALYSIS OF THE QUESTIONNAIRES

There are three main types of surveys: 'user evaluation', 'user opinion' and 'others' (Ozok 2012). A user evaluation survey provides data on the actual system, for

example if a product meets expectations. A user opinion survey will result in more general data about a system, for example what they think of the requirements of the system. The last category refers to surveys that gather specific information, such as finding out about population's demographics. The survey undertaken in this thesis will be a combination of both the user evaluation and user opinion category. The first four questions are based on user opinion, and the last four are based on user evaluation. The purpose of this is to confirm there is a need for a system like PassivBIM, and how it could be improved.

The survey questions themselves can be open ended or scaled, and a mixture of both has been used in the PassivBIM survey. The majority of the survey responses are either 'Yes/No', and there is one purely open-ended question and one which uses a five point Likert scale (Ozok 2012). All the 'Yes/No' questions have also an open-ended component, to encourage more feedback. Nine out of ten of the survey questions result in numeric data which can be analysed quantitatively and one question is used directly as an insight for possible future work directions.

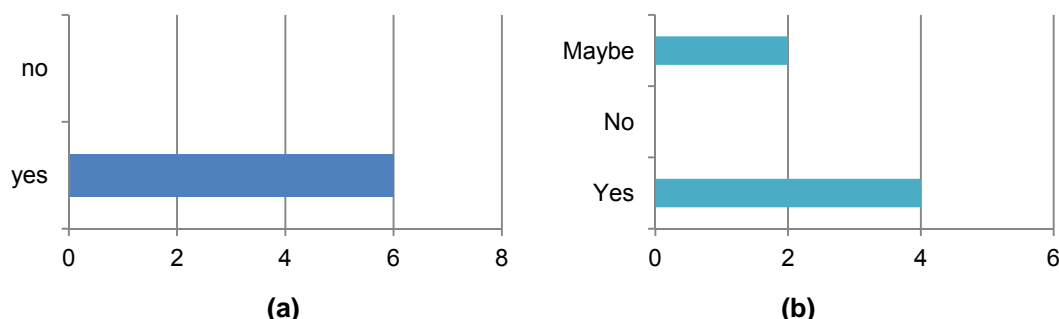
### 8.3 RESULTS AND DISCUSSION OF THE USABILITY TESTING

In general the participants gave rich feedback. However, it is key to note that there were several problems with the software used (GoToMeeting), which would have made recording the participants reactions impossible. Fortunately, the main data collection method was the survey, so this did not negatively impact the findings.

The first question in the survey is: *would you agree with the statement that the automation of some of the data input into PHPP could save you time?* The response is shown in Figure 8.2(a). It clearly shows that the automation of input into PHPP is regarded as time saving. It is therefore confirmed that there is a market for a tool which would automate data input. No extra comments were given in response to the question. ***PassivBIM has the potential to be efficient, as the automation would be time saving.***

The second question is: *would you agree that a tool which could instantly calculate the PHPP energy demand of a BIM model would enhance the design process?* The response in Figure 8.2(b) identifies an overall agreement with the statement, although there was some hesitancy with two participants stating 'maybe'. The feedback on the question explains this hesitancy, and can be found in Figure 8.3. The first comment is about BIM only being used in the later stages of design. This will not be an issue in the future, as the adoption of BIM becomes prolific over the whole building lifecycle. The second comment shows that the openness of PHPP is

appreciated, so a future prototype should (a) not hide the relationships between figures, and (b) instantly update heat demand results every time an input field changes. **These answers show that PassivBIM could be effective, as it enhances the design process through instantly calculating heat demand.**



**Figure 8.2 (a) Question 1: Would you agree with the statement that the automation of some of the data input into PHPP could save you time? and (b) Question 2: Would you agree that a tool which could instantly calculate the PHPP energy demand of a BIM model would enhance the design process?**

*Comment 1: "It would **depend on the level of modelling** required prior to the calculation - most designers only move to a BIM basis later in the design process and may need the results of the PHPP sooner than that."*

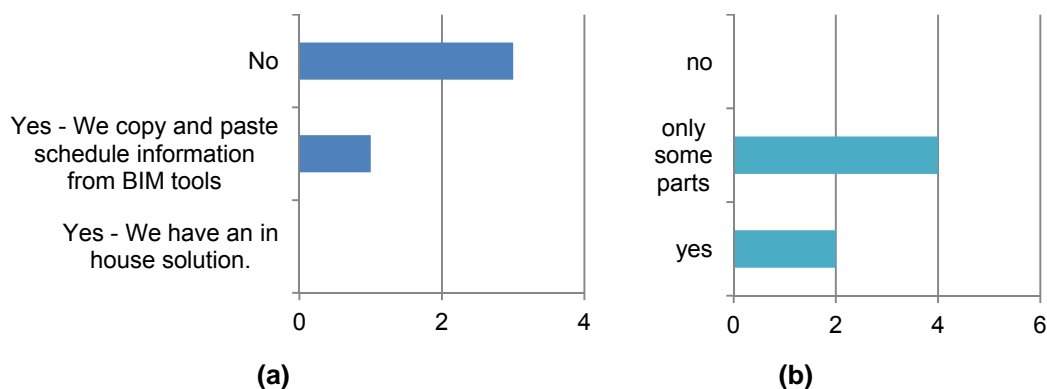
*Comment 2: "Maybe as long as the **input going in was understandable** and the **output was also understood** correctly. That is the beauty of the PHPP spreadsheet that can you can **clearly see all the relationships** between the information going in and output calculation. It is not a black box."*

**Figure 8.3 Comments on the second question.**

This is followed by the third question: *do you or your practice use any automation of data entry between BIM/CAD tools and energy analysis tools?* Figure 8.4(a) shows that the integration of BIM and energy analysis tools is still not integrated in practice by architects and Passivhaus designers. More information on the answers can be found in Figure 8.5. It can be seen that ArchiCAD users have access to 'eco designer', which enables the transfer of geometry from an ArchiCAD BIM authoring tool to PHPP. The second comment explains why one participant skipped the question: they do not use BIM. The third comment in conjunction with Figure 8.4(a) confirms a 'copy and paste' method of transferring data is mainly used at the moment. **In terms of efficiency, the answers to the third question show PassivBIM has the potential to speed up the process of sustainable design as data entry is not already automated between BIM and BPS tools.**

The fourth question was: *in your opinion, are some PHPP input calculations, such as the Treated Floor Area, open to interpretation and therefore error?* The purpose

of this question was to identify which parts of the PHPP may need to be more rigorously defined before they can be turned into computer based rules. The results are in Figure 8.4(b), and the comments are presented in Figure 8.6. From these two sources, a case can be put forward that the TFA calculation can be a source of confusion. It would need to be revised before it could be implemented in a computer system. This agrees with findings from the case study testing in Chapter 6. It must be stated at this point that no other part of PHPP is identified as problematic. Once PassivBIM would completely automate the TFW calculation, it would be highly effective.



**Figure 8.4 (a) Question 3: Do you or your practice use any automation of data entry between BIM/CAD tools and energy analysis tools? and (b) Question 4: In your opinion, are some PHPP input calculations, such as the Treated Floor Area, open to interpretation and therefore error?**

*Comment 1: "BRE don't do this work, and privately I don't do my small projects in BIM"*

*Comment 2: "We have developed our **Revit templates** to produce a certain amount of useful information for entry into PHPP."*

*Comment 3: "We have a link with **eco designer**"*

**Figure 8.5 Comments on the third question.**

The fifth question in the survey is: *could you envisage a tool such as PassivBIM being adopted in your practice?* The results are shown in Figure 8.7(a), and indicate that the participants themselves are prepared to welcome a tool such as the PassivBIM system to their workflow. The comments on the question are in Figure 8.8. They confirm that there is no serious issue identified with the adoption of PassivBIM, and it already does more than just calculate the TFA. The point is made that the tool would have to be trialled and validated. This of course would happen as part of the development of a tool; usually several versions are released for further testing once an interface is available and there is more confidence that it could handle complex geometry. **These results highlight PassivBIM is found to be satisfactory in general as participants would be happy to adopt it.**

*Comment 1: "The TFA seems to cause much confusion, even experienced personnel create different answers"*

*Comment 2: "As I understand them, yes, but it should be something that can be clarified."*

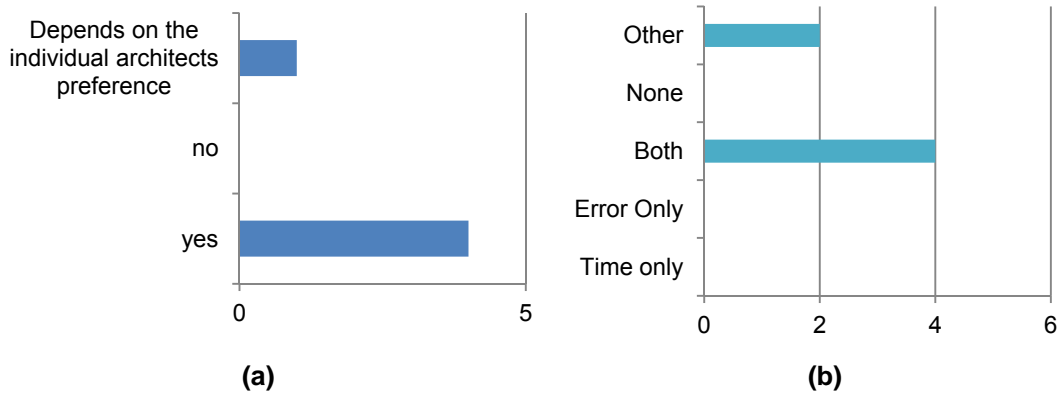
*Comment 3: "The PHI TFA definition is **under constant flux**, for example the services area previously assigned at 60% in residential building is now allowed at 100%. Basements, lofts (accessible only by loft ladders) and communal areas are complex and hence potentially subject to interpretation"*

*Comment 4: "I'm not quite sure I understand the question, TFA guidelines are pretty clear. However, when working in BIM not all areas that would be defined as a room suit each TFA category - eg parts of room that are lower than 1.5m wouldn't be defined as a separate room in BIM but need to be for PHPP."*

*Comment 5: "I can imagine that **some areas below staircases could currently cause confusion/ errors** when calculating TFA, i.e. should only count parts above 1m @ 50%, but the area under stairs could go to ground. A tool could actually help eliminate such ambiguity if it is always able to identify the correct area for consideration. Also, there could be ambiguity when considering circulation spaces and mechanical rooms. But I guess it would be up to the user to assign these in the building model and the tool will calculate the TFA accordingly. That happens with PHPP anyway at the moment, so it would certainly be no worse."*

**Figure 8.6 Comments on the fourth question**

The sixth question was: *do you agree that a tool such as PassivBIM could save the user time and reduce error?* The purpose of this is to establish if PassivBIM could be associated with time and error saving benefits. The results shown in Figure 8.7(b) confirm that this is valid, but there are some reservations. Figure 8.9 gives more details on the participant's concerns. The first two comments in Figure 8.9 reiterate that it would need to be trialled and validated, and proven to give the right results to gain users trust. The third comment is about PassivBIM being used for certification. The tool does already export building area elements to PHPP, so it could be used in the certification process, but not directly. Currently, the PHI has not been approached with the question of PassivBIM being part of the certification process, but this could be a possible future direction. **The answers to the sixth question shows PassivBIM could be efficient, as it results in a time and cost savings.**



**Figure 8.7(a) Question 5: Could you envisage a tool such as PassivBIM being adopted in your practice? and (b) Question 6: Do you agree that a tool such as PassivBIM could save the user time and reduce error?**

*Comment 1: "I can envisage BRE providing the tool to architects, yes"*

*Comment 2: "Yes with the proviso that it would need to do more than calculate the TFA and would need to be trialled and validated"*

**Figure 8.8 Comments on the fifth question.**

*Comment 1: "Potentially both if properly **triallyd and validated**"*

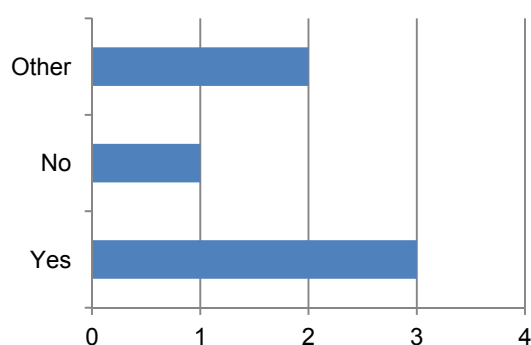
*Comment 2: "It would **definitely save some time**, however, we would need to be able to **check the accuracy** (eg wall area measurements in REVIT don't match PHPP requirements) to be really confident in using it for an actual PHPP model. I would see more use of PassivBIM for quick and rough early stage comparisons."*

*Comment 3: "Depends on what the output is - **can it actually be used for PH certification**, otherwise it would not speed up the process for us."*

**Figure 8.9 Comments on the sixth question.**

The seventh question was: *do you think that your workflow would benefit from streamlining data transfer from BIM to PHPP using PassivBIM?*. The results are in Figure 8.10, and show quite a divided opinion. Some of the reason may be that BIM is not heavily used by some of the participants, so they may not be able to express their opinion on how it would change a BIM-based workflow. It could also be due to them considering only the high level workflow in terms of the RIBA stages, which would not change simply due to a different tool being used. It is possible more clarification would be needed. The diagram of the assumed current workflow in Figure 4.6 could be used as a base, then it could be updated and simplified, and used to see if the opinions of the participants would change.

The general opinion related to question seven can be found in Figure 8.11. They clarify the reason for the divided opinion to some extent. The first comment refers to a previous answer ('yes' to the question of the automation of data input into PHPP). It therefore supports the idea that PassivBIM having a positive effect on the workflow. The second comment shows that it would need to be further developed. This comes from the participant who earlier said it would need to do more than calculate TFA. It is likely in this case that the further development refers to it automating all geometry: building elements, shading, windows etc. Additionally, they mention integrating the tool with SketchUp. The PassivBIM tool is aimed at an era where BIM will be commonly used at the conceptual design stage, so this point will not be valid in the future. Furthermore, the literature review in Chapter 4 revealed a tool already exists which exports data from SketchUp to PHPP. It does show that if PassivBIM wanted to target the current market, it may have to consider integrating itself with currently used conceptual design tools. The third comment shows the participant did not understand the question correctly as it made the point that Revit geometry is not suitable for PHPP. PassivBIM processes geometry so they are PHPP calculation ready. It is possible that this may not have been understood by others also, and that feedback would be more positive if the internal workings of the proposed system were explained in more detail. The last comment is arguably the most useful, as it shows a future direction. The focus should not be on processing geometry and entering data, but also on updating PassivBIM with some of the databases of information which are in PHPP. It is assumed the participant was alluding to for example the range of climate files available. ***The PassivBIM system could have the potential to enhance the Passivhaus design workflow, but more research would have to be done to reach a more conclusive answer.***



**Figure 8.10 Question 7: Do you think that your workflow would benefit from streamlining data transfer from BIM to PHPP using PassivBIM?**

*Comment 1: "Yes, noting q1 answer"*

*Comment 2: "Not currently as I think the tool needs further development as there are too many limitations to make its use worthwhile or time saving at this stage. **With further development it has huge potential** to streamline work flows especially if also integrated with an early stage design tool like SketchUp for example."*

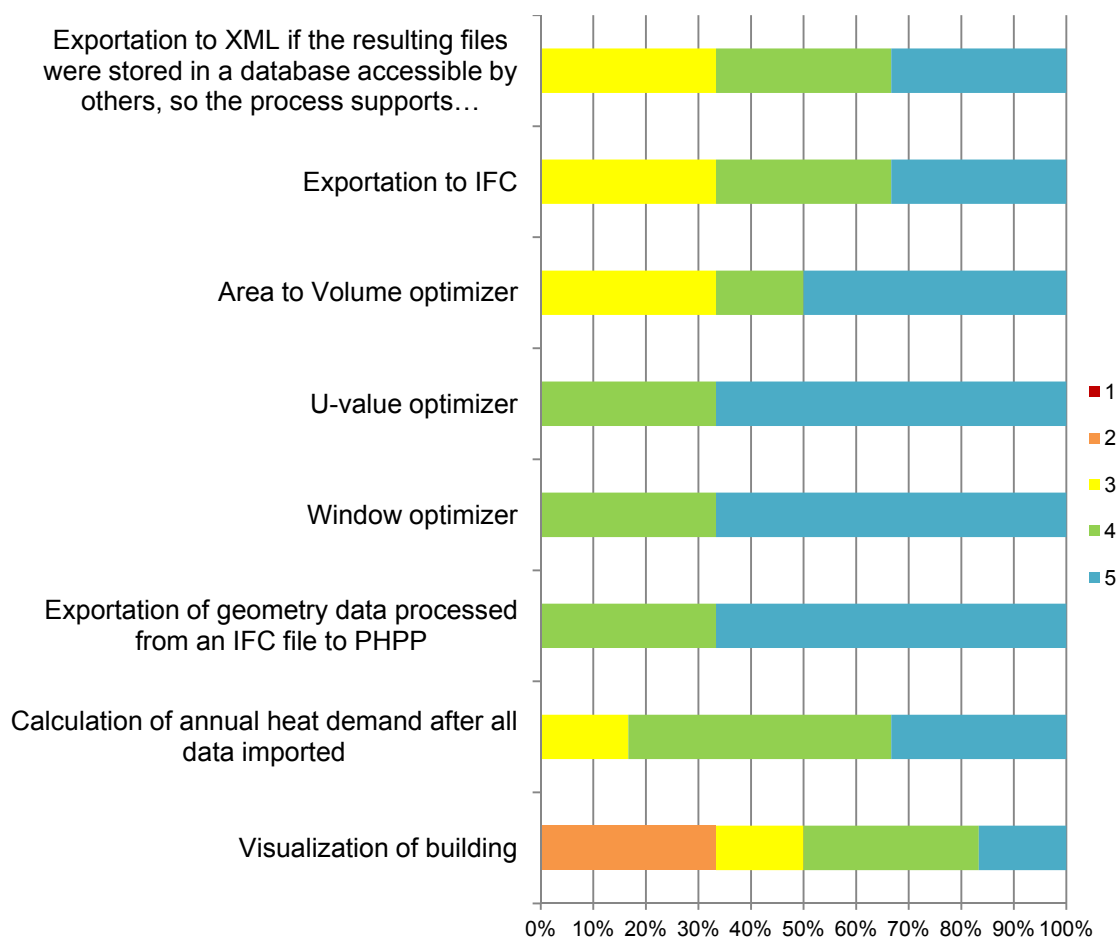
*Comment 3: "I'm **not so sure** - see my answer to the previous question. Some measurements in Revit don't suit PHPP requirements - wall areas for example."*

*Comment 4: "Maybe - haven't seen how you get the **database info in PHPP** yet. That is the key bit."*

**Figure 8.11 Comments on the seventh question.**

The eighth question involved rating various aspects of the PassivBIM system using a scale of 1-5, where 1 was not useful and 5 was very useful. The results are shown in Figure 8.12. The most useful features can be seen to be exportation of data, and the window and U-value optimiser. It also shows that exporting geometry is as important as features which inform design decision making. Visualising the building was seen on average as the least important. This is surprising as it would have been expected that at the conceptual design stage this would be rated as an important feature in order to see what affect optimising details had on the look and feel of the building. The second least important features are exporting to IFC and XML. It is possible that in the future, the exportation to IFC will be more important in the future when servers are used to store all the building project information. **The results to the eighth question demonstrate that there is a high level of satisfaction with the design informing functions.**





**Figure 8.12 Question 8: Illustrating the most important features of the tool.**

The ninth question was: *please describe any features you feel that are missing*. There is no quantitative data for question 9, as its main purpose was to objectively ascertain what the respondents viewed as the main limitations of the tool. The main views are in Figure 8.13. A general conclusion that can be made is that the optimisers were perceived very positively, but they would need further development. An idea was put forward that areas which cause the building to have a poor surface to volume ratio could be highlighted in the visualisation of the building. This concept could be extended to visually show problematic areas in building. For example, which windows cause high levels of glare or what parts of the building are more likely to overheat. A comment has also been made about the calculation of shading device geometry being difficult in PHPP. This is a limitation of PassivBIM, as it does not currently address this issue. It could however be extended with this functionality easily, as existing geometry processing algorithms could be used after being adapted to: (1) read shape and placement data of objects outside of the external walls, and (2) calculate relevant data about their relationship to the windows. ***This shows that with further development, the PassivBIM system could be an effective system which would be appreciated by users.***

*Comment 1: “Automation of optimisers and highlighting of areas which have poor surface:volume ratios (as opposed to overall).”*

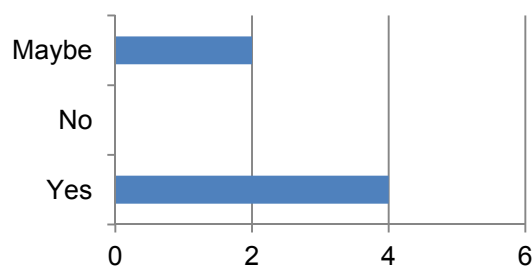
*Comment 2: “Peak load optimiser, overheating risk optimiser, hygro-thermal assessment and combined multi parametric/ multivariate and transient time series optimisation against pre-selected criteria... now that would make a useful tool!”*

*Comment 3: “Shading optimisation, orientation optimisation, Visual feedback on what data has been entered and what data has been generated by the tool from assumptions”*

*Comment 4: “How are shading devices calculated - this is the hardest bit to enter into PHPP and the bit that CAD/BIM would most be able to help”*

**Figure 8.13 Comments on the ninth question.**

The last question is: *If the PassivBIM tool was adapted based on your feedback, would you consider its adoption?* Figure 8.14 shows that the feedback was in general positive, although some participants were not completely certain. Their comments are in Figure 8.15, and present some very different viewpoints. The first comment is that ArchiCAD is used as a BIM tool, which already has the exportation to PHPP capability. In this case, there would not be as much of a reason to change to PassivBIM. Of course, PassivBIM would have the extra capability of informing design, and if it was further developed it could still be interesting to the ArchiCAD user market. The second comment is reiterating a point about more features having to be incorporated into the PassivBIM tool. The consecutive comment is more general in nature, and expresses the participant’s opinion in several areas. Firstly, the ‘*comments*’ parameter in Revit is currently used to influence the percentage of a floor area that needs to be counted towards the TFA. This is deemed as unwise by the participant, as the area could be needed for another purpose. This shows that a property set should be developed which would take over the role of providing a place for the user to signal how much area is applicable. The participant also demands that assumptions made should be clear and editable by the users of PassivBIM. At the moment, all the data is editable which goes into PassivBIM so it could be argued that no assumptions are made. Lastly, it is reiterated that PassivBIM should be open, as PHPP is. The final comment is concerned with the usability of the tool. This would be the next stage of development: users testing a working interface and using the feedback to develop a simple, easy to navigate in product. ***The results of the last question show that there are areas to be developed before the tool is fully effective, but users are satisfied with its functions.***



**Figure 8.14 Question 10: If the PassivBIM tool was adapted based on your feedback, would you consider its adoption?**

*Comment 1: "We don't really use **Revit**, but are Archicad Users".*

*Comment 2: "If it could **do all or most of the above** then it would be a viable as a commercial alpha release".*

*Comment 3: "Some other comments - - Looks great for testing options quickly using BIM & PHPP so we know it has high level of accuracy - I would suggest introducing a new shared parameter for TFA or other PHPP related fields and **avoid using the "comments" parameter** as this could easily be needed for something else resulting in a conflict - For us to trust and want to use a tool like this we need to see clearly **what assumptions are being made** (eg default PH u-values, window values, MVHR performance...?) and to be able to quickly and easily access the assumptions to alter them. This is why we like PHPP, it is **open and accessible**. - Great job so far though and best wishes for taking it further, would love to be involved in alpha/beta testing etc if you do develop it further".*

*Comment 4: "Would need to see how **usable** it was generally".*

**Figure 8.15 Comments on tenths question.**

## 8.4 CONCLUSIONS

This chapter established how the possible application of PassivBIM is regarded by potential users, and how it could benefit from future development.

Section 8.1 showed that multiple definitions of usability exist, and that it is relied on by a range of domains. Usability testing can be undertaken with either an inspection-based or user-based method. The most suitable method for PassivBIM at this stage of the software development is the user-based questionnaire. Issues such as the amount of participants were discussed. (Section 8.2). *The early stage of software development has been tested using a questionnaire. Later on in the software development, it should be tested again using alternative participants and methods.*

Based on section 8.3, the following conclusions can be made using the performance metrics identified for this approach:

- Effectiveness: The PassivBIM system enhances sustainable design by supporting BIM-based energy calculations. Additionally, it has the potential to support design decision-making and the Passivhaus certification process.
- Efficiency: PassivBIM's capability to save time was confirmed on two different levels. In the first instance, it generally automates data entry into an energy analysis tool. Secondly, it addresses the issue of the TFA calculation which is identified as problematic. It was also agreed that it could stop errors being made.
- Satisfaction: There was a general positive attitude towards PassivBIM. Participants indicated they would be happy to adopt the tool, and that in particular the design informing functions were useful. In order for participants to display full satisfaction, there are areas which need to be revised and extended. One of the first areas that could be addressed is calculating details about shading devices, as existing PassivBIM shape and placement algorithms could be reused.

## Chapter 9 CONCLUSIONS AND FUTURE WORK

The aim of this thesis is to improve the building design and energy analysis process by focusing on interoperability between tools, and to facilitate the design of low energy buildings. This was fulfilled by achieving the objectives stated in Chapter 1, and by addressing the research questions. This chapter starts with a summary of the research steps taken to fulfil the research objectives (section 9.1). Concluding remarks are then presented (section 9.2) and future work is proposed (section 9.3).

### 9.1 SUMMARY

The thesis began with an introduction to BIM and sustainable design, and identified the problems connected with both (Chapter 1). The thesis continued with Chapter 2, which gave details of sustainable building rating systems and standards, and also outlined some of the tools that they are supported by. BREEAM and LEED were identified as being widely used, and they have been used as reference models in the development of other rating systems. Overall, the Passivhaus standard is identified as being able to achieve the highest energy efficiency savings.

Chapter 3 reviewed the adoption process of BIM. It is being implemented worldwide, and there are many benefits connected to its use. They can be grouped by the following categories: cost, time, quality and productivity. One of the remaining barriers to BIM adoption is interoperability.

This was followed by Chapter 4, which focused on the interoperability issues between BIM and energy analysis tools. Many data standardisation efforts have been undertaken in the past. Two of the most commonly used schemas for transferring data between BIM and energy analysis tools are IFC and gbXML. The IFC schema can describe the whole building lifecycle, but it lacks an energy domain. It is also available in two formats, XML and EXPRESS. The XML version was developed in this study as there are more tools available which can manipulate it. The PHPP tool was identified as having low interoperability. *This fulfils the first objective, which is to perform a literature review that identifies a problematic area in the interoperability between BIM and energy analysis tools.*

In Chapter 5, the IFC schema was revised and extended with an energy analysis domain. The organisation and nomenclature of this extension was based on the structural analysis domain. The requirements for the extension originate from the PHPP annual heat demand calculation. It is key to note that any BPS tool could

have been chosen in the place of PHPP. *This chapter shows the second objective was met, which is to extend the IFC schema so it can store energy related data.*

The IFC extension was then converted into Java classes which formed the basis of a prototype tool. This tool can read IFC files which have been generated by BIM tools. It processes their geometry into a PHPP compatible format. It can also accept user input, or XML files which are generated by the XML Template document. The XML Template document is a MsExcel spreadsheet, which uses a macro to extract data from PHPP files. This macro places the data into cells which have been mapped to a simplified version of the IFC extension. A simplified version had to be used as the full extension was not compatible with MsExcel. The Java prototype was then enhanced with design informing functions, and the ability to calculate the annual heat demand. It can also export processed IFC geometry to PHPP. This whole system is referred to as PassivBIM throughout the thesis.

The PassivBIM system was validated in Chapter 6 using two case studies: Hannover Kronsberg and the Larch House. The former case study has previously been validated against measured data. Both of the case studies showed examples of how PassivBIM can inform design decision making. The main areas were building optimisation and masterplanning. *This chapter shows the third objective has been achieved, which is to implement a prototype based on the extended IFC schema.*

The potential of the PassivBIM system was then ascertained with usability testing. A presentation was given to 6 participants, and then an online questionnaire collected their views on the system. The results were analysed, and conclusions were made using the performance metrics: effectiveness, efficiency and satisfaction. *The fourth objective was therefore accomplished in this chapter. The fourth objective was to present a prototype interface to the target audience, so the results can be used to gauge the perceived need for the tool, and to determine future directions.*

As discussed in chapter one, there are several problems related to BIM and BPS. The following summarises these problems, and shows how PassivBIM addresses them:

- First, the need for sustainable design is argued (section 1.1.1). There are many issues with BPS tools, such as they are being used late in the design process, and they lack the capability to compare alternative designs. Rating systems also tend to be undertaken late in or after the design process. Due to the current level of emissions and their predicted negative effect on the

climate, it is urgently required that new buildings are highly energy efficient. *The PassivBIM system supports conceptual design and semi-automates data input.*

- The time-saving and financial incentives of BIM adoption were also outlined (section 1.1.2). By adopting the BIM process, the construction industry would benefit from cost-savings, and companies could profit from a ROI. After it has been commonly implemented, general time saving measures could be put into practise, for example automated building plan checking. *The PassivBIM tool encourages BIM adoption, and reuses data from BIM models.*
- Issues with BIM and BPS tools were also highlighted (section 1.1.3). There is a need to support a single neutral data standard, which would store both dynamic and static parameters. Additionally, existing issues with interoperability need to be addressed. *The IFC was extended with an energy analysis domain, and facilitates data transfer between BIM-based tools and PHPP.*

## 9.2 CONCLUDING REMARKS

The hypothesis of the thesis is that existing data transfer methods can be extended in a way to address current issues with interoperability, in order to support decision-making in sustainable building design. Two main research questions were developed to prove if this hypothesis is true.

The first research question posed was: how can an extension to an existing data transfer schema support building design and assessment? The following method was followed to answer this question:

- (i) Analysing the interoperability between tools used for building design, and tools that support rating systems and standards.
- (ii) Developing an extension to the data transfer schema which addresses an interoperability issue.

The literature review performed in Chapters 2 to 4 addressed part (i). Findings include that BPS tools were found to improve the sustainable design of buildings. Their use should not be limited to supporting a single standard or sustainable building rating system. If new tools are being developed, they should also aim to be

compliant with a mature level of BIM. Existing BIM-based tools were found to result in benefits such as time and cost reduction. Part (ii) was fulfilled by Chapter 5. It was found that the current IFC schema could not transfer all the data necessary for an energy analysis. The schema was therefore extended to include energy concepts from the PHPP tool. The extension was based on the existing structural analysis domain, for consistency.

The second research question proposed was: how can an extension be used to develop a tool which supports sustainable design? The method to answer this question involved the following:

- (i) Implementing the extension to create a prototype tool which can be used for sustainable design.
- (ii) Validating the prototype tool and its proposed interface.

Part (i) was covered in Chapter 5. The extension was implemented as a BIM neutral tool, which can read and write different file formats. The prototype encourages low energy design with functions which inform design decision-making. These include functions which can optimise the characteristics of building elements and facilitate masterplanning. The tool can calculate the annual heat demand necessary for PHPP. This could be extended in the future to support other energy performance standards, and sustainable building rating systems. The tool can process geometry data from an IFC file, and the remaining data can come from either a user or PHPP. Geometry is processed in order for it to be PHPP compatible. This geometry can also be exported straight to PHPP. As a result, the tool supports the process of Passivhaus certification. Part (ii), the validation of the PassivBIM prototype was documented in Chapter 6. The PassivBIM system was validated using several case studies. Three main validations took place: (a) the geometrical processing of IFC data, (b) the annual heat demand calculation, and (c) the ability to export to PHPP and XML. It was found PassivBIM can interpret the geometry from different building types (terraced and detached buildings) and interpret where the building envelope ends. It was shown it can export to both XML files, and PHPP. In addition, it can be used to compare different building designs. The tool can also claim to support Level 2 BIM maturity, and it could be upgraded to a Level 3 by adding the capability of exporting to IFC files. This was not attempted, as the main validation process would include another BIM tool reading the generated file, and it was found that existing



BIM authoring tools had issues reading files they produced themselves. As a result, the validation would not have been reliable at this stage.

Overall, it can be concluded that the hypothesis is proven correct. The PassivBIM prototype is based on an extension of the IFC schema, and addresses the low interoperability between BIM-based tools and PHPP, whilst informing decision making and supporting the Passivhaus certification process.

## 9.3 FUTURE CHALLENGES

### 9.3.1 FURTHER TESTING

The PassivBIM tool could be tested with more case studies, which would include more complex geometry and originate from different BIM tools. A range of methods can be applied to do this, such as (a) using real life case studies of other existing Passivhaus buildings, (b) using other BIM authoring tools to generate IFC files as the consistency of output files has been argued as a problem in the past, (c) eventually releasing an alpha version to the public and requesting problematic files to be sent back to the prototype developers for further analysis and (d) approaching buildingSMART and requesting access to building models that they use to certify if a software product meets the IFC standard.

### 9.3.2 SENSITIVITY ANALYSIS AND OPTIMISING CAPABILITIES

The design informing functions were met with approval from industry in the usability testing, and suggestions were given for other capabilities. These included: a peak load optimiser, overheating risk optimiser, hygro-thermal assessment and combined multi parametric/multivariate and transient time series optimisation against pre-selected data, shading optimisation, orientation optimisation. A future research question for this line of work could be: *How can sensitivity analysis and design optimisation enhance the design process of sustainable buildings under the BIM paradigm?*

The usability testing also highlighted that entering data about shading devices is very complex. This could be addressed by adapting existing PassivBIM algorithms, to be able to calculate the geometry of shading devices and their effect on the building in question.

### 9.3.3 EXTEND IMPORT AND EXPORT CAPABILITIES

In the Level 3 of BIM adoption, data will be transferred in an IFC format. The PassivBIM tool would benefit from being extended to export files that are compatible with IFC servers.

Furthermore, PHPP calculations rely on either default or custom defined climates. PassivBIM can be developed to accept some standard climate files as input, and to manipulate them into the PHPP format. Consequently, PassivBIM would be able to test the resilience of a building to climate change using externally developed future weather files.

PassivBIM could also be extended to be able to accept files from other BPS tools, or to export to other BPS tools. This would involve revising the IFC energy analysis extension, and as a result the PassivBIM tool will support other sustainable building rating systems and standards.

#### *9.3.4 DATABASE OF DEFAULT OR RECOMMENDED VALUES*

As the tool is currently aimed at the conceptual design stage, there is the opportunity to extend it to provide default values or make assumptions to decrease the amount of input necessary. This could be linked to databases of recommended values based on past completed projects, or actual products that would be updated by the PHI.

#### *9.3.5 INTERFACE*

A graphical user interface to PassivBIM would enable building designers to easily access all of PassivBIM's features. The development would include further usability tests. In addition, the tool could be made available as a plug-in, as the maturity of BIM is not at a level where IFC are commonly used to store and transfer data.

## REFERENCES

- AISC 2013. CIS/2 [Online]. Available at: <http://www.aisc.org/content.aspx?id=26044> [Accessed: 19 March 2013].
- Apache POI 2012. Apache POI - the Java API for Microsoft Documents [Online]. Available at: <http://poi.apache.org/> [Accessed: 29 May 2013].
- Arayici, Y., Coates, P., Koskela, L., Kagioglou, M., Usher, C. and O'Reilly, K. 2011. Technology adoption in the BIM implementation for lean architectural practice. *Automation in Construction* 20(2), pp. 189–195.
- Armstrong, M. and Henderson, J. 2009. Green Standards and Rating Systems: Whats the difference? [Online]. Available at: <http://bsj.iccsafe.org/december/features/green.html> [Accessed: 13 June 2013].
- ASHRAE 2009a. *ASHRAE 2009 handbook: fundamentals*. Atlanta, GA: American Society of Heating, Refrigerating and Air-Conditioning Engineers, Inc.
- ASHRAE 2009b. *ASHRAE Standard. Energy Standard for Buildings Except Low-Rise Residential Buildings. Addendum r to Standard 90.1-2007*.
- Attia, S., Gratia, E., De Herde, A. and Hensen, J. 2012. Simulation-based decision support tool for early stages of zero-energy building design. *Energy and Buildings* 49, pp. 2–15.
- Attia, S., Hensen, J., Beltrán, L. and De Herde, A. 2012. Selection criteria for building performance simulation tools: contrasting architects and engineers needs. *Journal of Building Performance Simulation* 5(3), pp. 155–169.
- Autodesk, Inc. 2013a. Autodesk Green Building Studio [Online]. Available at: <http://usa.autodesk.com/green-building-studio/> [Accessed: 13 June 2013].
- Autodesk, Inc. 2013b. Autodesk Labs Graduates [Online]. Available at: [http://labs.autodesk.com/utilities/photo\\_scene\\_editor/](http://labs.autodesk.com/utilities/photo_scene_editor/) [Accessed: 11 June 2013].
- Autodesk, Inc. 2013c. Autodesk Revit Extension for CASBEE [Online]. Available at: <http://www.autodesk.co.jp/adsk/servlet/item?siteID=1169823&id=15808964&linkID=15311579> [Accessed: 14 June 2013].
- Autodesk, Inc. 2013d. Revit for Architectural Design [Online]. Available at: <http://www.autodesk.co.uk/adsk/servlet/pc/index?siteID=452932&id=18670673> [Accessed: 23 March 2013].
- Azhar, S., Brown, J. and Farooqui, R. 2009. BIM-based Sustainability Analysis: An Evaluation of Building Performance Analysis Software. In: *Proceedings of the 45th ASC Annual International Conference*. Gainesville, Florida.
- Azhar, S., Hein, M. and Sketo, B. 2008. Building information modeling (BIM): Benefits, risks and challenges. In: *Proceedings of the 44th ASC Annual Conference*. Auburn, Alabama.
- Bastien, J.M.C. 2010. Usability testing: a review of some methodological and technical aspects of the method. *International Journal of Medical Informatics* 79(4), pp. e18–e23.
- Bazjanac, V. 2001. Acquisition of building geometry in the simulation of energy performance. In: Rio de Janeiro, Brazil.
- Bazjanac, V. 2008. IFC BIM-based methodology for semi-automated building energy performance simulation. In: *CIB W78 25th International Conference on Information Technology in Construction*. Santiago: Universidad de Talca.
- Bazjanac, V. 2004. Virtual Building Environments - Applying Information Modeling to Buildings. In A. Dikbas and R. Scherer (eds). In: *eWork and eBusiness in architecture, engineering and construction*. London: Taylor & Francis Group.

- Bazjanac, V. and Kiviniemi, A. 2007. Reduction, simplification, translation and interpretation in the exchange of model data. In: *Proceedings of the 24th CIB W78 conference*. Maribor, pp. 163–168.
- Bazjanac, V. and Maile, T. 2004. IFC HVAC interface to EnergyPlus-A case of expanded interoperability for energy simulation. In: *SimBuild 2004, IBPSA-USA National Conference Boulder*. CO, pp. 1–7.
- Bazjanac, V., Maile, T., Rose, C., O'Donnell, J., Mrazović, N., Morrissey, E. and Welle, B. 2011. An assessment of the use of building energy performance simulation in early design. In: *Building Simulation 2011: 12th Conference of International Building Performance Association*. Sydney, pp. 1579–1585.
- BEAM Society 2012. *BEAM Plus New Buildings Version 1.2*.
- Beddoe, N. and Sutton, A. 2012. TSB Research Project. Design for Future Climate - Developing an Adaptation Strategy. [Online]. Available at: <http://www.bre.co.uk/filelibrary/pdf/projects/D4FC.pdf> [Accessed: 26 June 2013].
- Beetz, J. 2009. Facilitating distributed collaboration in the AEC/FM sector using Semantic Web Technologies. Eindhoven, The Netherlands: Technische Universiteit Eindhoven.
- Bentley Systems, Inc. 2013. AECOsim Energy Simulator [Online]. Available at: <http://www.bentley.com/en-GB/Promo/AECOsim/aecosim+energy+simulator.htm> [Accessed: 13 June 2013].
- Bevan, T.L. 2011. How the new BREEAM 2011 version measures, quantifies and evaluates the key life cycle environmental impacts of new buildings at the design and construction stages. In: *CIBSE Technical Symposium*. DeMontfort University, Leicester, UK.
- BIM Industry Working Group 2011. *BIM. Management for value, cost and carbon improvement*. London.
- BIM-Tools 2013. BIM-Tools for SketchUp [Online]. Available at: <http://www.bim4sketchup.org/> [Accessed: 27 September 2013].
- Bjerg Arkitektur a/s 2013. ph-tool [Online]. Available at: <http://ph-tool.com/> [Accessed: 14 June 2013].
- Bjørkhaug, L. and Bell, H. 2012. dev.ifd-library.org [Online]. Available at: [http://dev.ifd-library.org/index.php/Main\\_Page](http://dev.ifd-library.org/index.php/Main_Page) [Accessed: 11 June 2013].
- BLIS Consortium and Digital Alchemy 2012. IFC Solutions Factory [Online]. Available at: <http://www.blis-project.org/IAI-MVD/> [Accessed: 10 September 2013].
- Bothwell, K., Saich, M. and Mallion, P. 2011. Retrofit of existing housing in the United Kingdom: the carbon reduction possibilities. In: *PLEA 2011 Conference on Passive and Low Energy Architecture*. Louvain-la-Neuve, Belgium, pp. 589–594.
- BRE 2011. Passivhaus: The Passivhaus Standard [Online]. Available at: <http://www.passivhaus.org.uk/standard.jsp?id=122> [Accessed: 5 June 2013].
- BRE Global 2013a. *BREEAM International New Construction Technical Manual*.
- BRE Global 2013b. BREEAM: the world's leading design and assessment method for sustainable buildings [Online]. Available at: <http://www.breeam.org/> [Accessed: 3 June 2013].
- Bryde, D., Broquetas, M. and Volm, J.M. 2013. The project benefits of Building Information Modelling (BIM). *International Journal of Project Management* In Press. Available at: <http://linkinghub.elsevier.com/retrieve/pii/S0263786312001779> [Accessed: 9 February 2013].
- bSI 2013. buildingSMART [Online]. Available at: <http://www.buildingsmart.org/> [Accessed: 8 June 2013].

- Building and Construction Authority 2013. CORENET [Online]. Available at: <http://www.corenet.gov.sg/> [Accessed: 16 June 2013].
- Building Research Establishment Ltd. 2009. National Calculation Method [Online]. Available at: <http://www.ncm.bre.co.uk/page.jsp?id=1> [Accessed: 11 March 2013].
- buildingSMART 2013. Industry Foundation Classes (IFC) [Online]. Available at: <http://buildingsmart.com/standards/ifc> [Accessed: 18 April 2012].
- buildingSMART International Ltd. 2013a. Home [Online]. Available at: <http://buildingsmart-tech.org/> [Accessed: 28 September 2011].
- buildingSMART International Ltd. 2013b. Model View Definition [Online]. Available at: <http://www.buildingsmart-tech.org/specifications/ifc-view-definition> [Accessed: 20 March 2013].
- Bunz, K.R., Henze, G.P. and Tiller, D.K. 2006. Survey of sustainable building design practices in North America, Europe, and Asia. *Journal of architectural engineering* 12(1), pp. 33–62.
- Cabinet Office 2011. *Government Construction Strategy*.
- Carassus, J. 2008. Energy efficient buildings: Models, innovation and market. In: *CIB W55-W65 Joint International Symposium 'Transformation through Construction'*. Dubai.
- Cemesova, A., Hopfe, C.J. and Rezgui, Y. 2013. Client-driven sensitivity analysis of the energy consumption of a welsh office building using probabilistic climate projections. In: *BS2013*. Chambéry, France.
- Cerovsek, T. 2011. A review and outlook for a 'Building Information Model' (BIM): A multi-standpoint framework for technological development. *Advanced Engineering Informatics* 25(2), pp. 224–244.
- Cho, C.S., Chen, D. and Woo, S. 2011. Building information modelling (BIM)-based design of energy efficient buildings. In: *2011 Proceedings of the 28th ISARC*. Seoul, Korea, pp. 1079–1084.
- CIBSE 2005. *TM36. Climate Change and the indoor environment: impacts and adaptation*. London: The Chartered Institution of Building Services Engineers.
- Communities and Local Government 2006. *Building a Greener Future: Towards Zero Carbon Development*.
- Cormier, A., Robert, S., Roger, P., Stephan, L. and Wurtz, E. 2011. Towards a BIM-based service oriented platform: application to building energy performance simulation. In: *Proceedings of Building Simulation 2011*. Sydney, pp. 2309–2316.
- Costa, A., Keane, M.M., Torrens, J.I. and Corry, E. 2013. Building operation and energy performance: Monitoring, analysis and optimisation toolkit. *Applied Energy* 101, pp. 310–316.
- Crawley, D.B. 2003. Presentation - ASHRAE Meeting Chicago.
- Crawley, D.B., Hand, J.W., Kummert, M. and Griffith, B.T. 2005. *Contrasting the capabilities of building energy performance simulation programs*.
- CRC Construction Innovation 2007. *Adopting BIM for facilities management*.
- Crosbie, T., Dawood, N. and Dawood, S. 2011. Improving the energy performance of the built environment: The potential of virtual collaborative life cycle tools. *Automation in Construction* 20(2).
- Crown 2013. Green Deal: energy saving for your home or business [Online]. Available at: <https://www.gov.uk/green-deal-energy-saving-measures/repayments> [Accessed: 12 March 2013].
- Davis, P. and Raianu, S. 2007. Computing areas using Green's Theorem and a Software Planimeter. *Teaching Mathematics and its Applications* 26(2), pp. 103–108.
- Dawood, S., Crosbie, T., Dawood, N. and Lord, R. 2013. Designing low carbon buildings: A framework to reduce energy consumption and embed the use of

- renewables. *Sustainable Cities and Society* In Press. Available at: <http://linkinghub.elsevier.com/retrieve/pii/S2210670713000061> [Accessed: 11 March 2013].
- Department for Communities and Local Government 2013a. Code for sustainable homes [Online]. Available at: <https://www.gov.uk/government/policies/improving-the-energy-efficiency-of-buildings-and-using-planning-to-protect-the-environment/supporting-pages/code-for-sustainable-homes> [Accessed: 12 March 2013].
- Department for Communities and Local Government 2013b. When will I get a decision? [Online]. Available at: <http://www.planningportal.gov.uk/planning/applications/decisionmaking/thedecision> [Accessed: 16 June 2013].
- DesignBuilder Software Ltd 2005. Version Features [Online]. Available at: <http://www.designbuilder.co.uk/content/view/70/112/> [Accessed: 13 June 2013].
- DesignReform 2011. Green Fund Passivhaus Series 01 - Intro to PH in Revit [Online]. Available at: <http://designreform.net/learning/2011/10/26/green-fund-passivhaus-series-01-intro-ph-revit-0> [Accessed: 17 January 2013].
- Ding, G.K.C. 2008. Sustainable construction—The role of environmental assessment tools. *Journal of Environmental Management* 86(3), pp. 451–464.
- DOE 2013. EnergyPlus Graphical User Interfaces [Online]. Available at: [http://apps1.eere.energy.gov/buildings/energyplus/ep\\_interfaces.cfm](http://apps1.eere.energy.gov/buildings/energyplus/ep_interfaces.cfm) [Accessed: 13 June 2013].
- Dong, B., Lam, K.P., Huang, Y.C. and Dobbs, G.M. 2007. A comparative study of the IFC and gbXML informational infrastructures for data exchange in computational design support environments. In: *Building Simulation 2007*. Beijing, China, pp. 1530–1537.
- Dumas, J.S. and Fox, J.E. 2012. Usability Testing. In: Jacko, J. ed. *Human-Computer Interaction Handbook: Fundamentals, Evolving Technologies, and Emerging Applications*. Third Edition. Boca Raton, FL: CRC Press, pp. 1222–1237.
- Duncan, G. 2011. Revit and PHPP: Getting BIM and Energy Modeling Software to Work Together. . Available at: <http://www.gduncan.us/?p=756> [Accessed: 17 January 2013].
- E4tech 2013. Lesosai 7.3□: certification and thermal balance calculation for buildings [Online]. Available at: <http://www.lesosai.com/en/index.cfm> [Accessed: 13 June 2013].
- East, E.W. 2013. Construction Operations Building Information Exchange (COBie) [Online]. Available at: <http://www.wbdg.org/resources/cobie.php> [Accessed: 11 June 2013].
- Eastman, C. 2009. Automated Assessment of Early Concept Designs. 79(2), pp. 52–57.
- Eastman, C. 1975. The Use of Computers Instead of Drawings. *AIA Journal* 63(3), pp. 46–50.
- Eastman, C., Teicholz, P., Sacks, R. and Liston, K. 2011. *BIM Handbook: A Guide to Building Information Modelling for Owners, Managers, Designers, Engineers, and Contractors*. Canada: John Wiley & Sons. Inc.
- Edwards 2013. 'designPH' plugin for Trimble Sketchup [Online]. Available at: [http://passipedia.passiv.de/passipedia\\_en/planning/calculating\\_energy\\_efficiency/php\\_-\\_the\\_passive\\_house\\_planning\\_package/designph\\_plugin](http://passipedia.passiv.de/passipedia_en/planning/calculating_energy_efficiency/php_-_the_passive_house_planning_package/designph_plugin) [Accessed: 14 June 2013].
- EG Science 2008. *The 2°C target*. EU Climate Change Expert Group.
- EGH 2012. Heidelberg-Bahnstadt [Online]. Available at: <http://heidelbergbahnstadt.de/en> [Accessed: 5 June 2013].

- EMSD 2007. *Performance-based Building Energy Code 2007 Edition*. Electrical & Mechanical Services Department.
- Encina Ltd 2013. Export gbXML from ArchiCAD [Online]. Available at: [http://www.encina.co.uk/gbxml\\_export.html](http://www.encina.co.uk/gbxml_export.html) [Accessed: 14 June 2013].
- European Commission 2008. Action Plan for Energy Efficiency: Realising the Potential. 2007/2106(INI). P6\_TA(2008)0033 [Online]. Available at: <http://www.europarl.europa.eu/sides/getDoc.do?pubRef=-//EP//TEXT%2BTA%2BP6-TA-2008-0033%2B0%2BDOC%2BXML%2BV0//EN> [Accessed: 12 March 2013].
- European Commission 2003. Directive 2002/91/EC of the European Parliament and of the Council of 16 December 2002 on the energy performance of buildings. *Official Journal of the European Communities*. Available at: <http://eur-lex.europa.eu/LexUriServ/LexUriServ.do?uri=OJ:L:2003:001:0065:0065:EN:PDF> [Accessed: 11 March 2013].
- FaJ 2012. *Minergie-P: Un plus dans la qualité de construction*. MINERGIE.
- Faulkner, L. 2003. Beyond the five-user assumption: Benefits of increased sample sizes in usability testing. *Behavior Research Methods, Instruments, & Computers* 35(3), pp. 379–383.
- Feist, W. 2006. Definition of Passive Houses [Online]. Available at: [http://www.passivhaustagung.de/Passive\\_House\\_E/passivehouse\\_definition.html](http://www.passivhaustagung.de/Passive_House_E/passivehouse_definition.html) [Accessed: 12 March 2013].
- Feist, W. 2007a. Passivhaus Energie bezugs fläche [Online]. Available at: [http://www.passivhaustagung.de/Passivhaus\\_D/energie\\_bezugs\\_flaeche.html](http://www.passivhaustagung.de/Passivhaus_D/energie_bezugs_flaeche.html) [Accessed: 16 April 2013].
- Feist, W. 2007b. PHPP: Far More Than Just An Energy Calculation Tool [Online]. Available at: [http://www.passivhaustagung.de/Passive\\_House\\_E/PHPP.html](http://www.passivhaustagung.de/Passive_House_E/PHPP.html) [Accessed: 3 November 2011].
- Feist, W. 1994. *Thermische Gebäudesimulation (Thermal Simulation of Buildings)*. First Edition.
- Feist, W., Peper, S., Kah, O. and von Oesen, M. 2005. *Climate Neutral Passive House Estate in Hannover-Kronsberg: Construction and Measurement Results*.
- Feist, W., Peper, S. and Oesen, M. von 2001. *CEPHEUS Projektdokumentation Nr. 18*. PassivHaus Institut.
- Feist, W., Pfluger, R., Kaufmann, B., Schnieders, J. and Kah, O. 2007. *Passive House Planning Package 2007*. Passive House Institute Darmstadt.
- Fies, B. 2012. *Deliverable 6.3 Recommendations for the integration of sustainable building assessment and benchmarking methods with BIMs*.
- Foley, J.D., van Dam, A., Feiner, S.K. and Hughes, J.F. 1996. *Computer Graphics: Principles and Practise*. Second Edition. Reading, Massachusetts: Addison-Wesley Publishing Company, Inc.
- Forbes, L.H. and Ahmed, S.M. 2011. *Modern Construction: Lean Project Delivery and Integrated Practices*. Boca Raton, FL: CRC Press.
- Fowler, K.M. and Rauch, E.M. 2006. *Sustainable building rating systems summary*. Pacific Northwest National Laboratory (PNNL), Richland, WA (US).
- Gardzelewski, J. 2009. GREEN BIM NETWORK: Ecotect within Revit [Online]. Available at: <http://greenbimnetwork.blogspot.co.uk/2009/08/ecotect-within-revit.html> [Accessed: 22 March 2013].
- GBCA 2013. Green Star Project Directory - Green Building Council Australia (GBCA) [Online]. Available at: <http://www.gbca.org.au/project-directory.asp> [Accessed: 4 June 2013].
- gbXML 2012. Green Building XML Schema [Online]. Available at: <http://www.gbxml.org/> [Accessed: 21 March 2013].

- Gelbrich, U. and Reinwaldt, G. 1995. *Dictionary of Building and Civil Engineering: English-German - Google Books*. Berlin-Paris: Verlag Alexandra Hatier GmbH.
- Gething, B. 2011. *Green Overlay to the RIBA Outline Plan of Work*.
- Gilligan, B. and Kunz, J. 2007. *VDC use in 2007: significant value, dramatic growth, and apparent business opportunity*. Stanford University: Center for Integrated Facility Engineering.
- De Gracia, A., Rincón, L., Castell, A., Jiménez, M., Boer, D., Medrano, M. and Cabeza, L.F. 2010. Life Cycle Assessment of the inclusion of phase change materials (PCM) in experimental buildings. *Energy and Buildings* 42(9), pp. 1517–1523.
- Granadeiro, V., Duarte, J.P., Correia, J.R. and Leal, V.M.S. 2013. Building envelope shape design in early stages of the design process: Integrating architectural design systems and energy simulation. *Automation in Construction* 32, pp. 196–209.
- Graphisoft 2005. *Energy analysis with ArchiCAD*.
- Graphisoft 2013a. Graphisoft EcoDesigner Star [Online]. Available at: <https://edstarbeta.graphisoft.com/#/overview> [Accessed: 12 June 2013].
- Graphisoft 2013b. IFC Support [Online]. Available at: <http://www.graphisoft.com/support/ifc/> [Accessed: 23 March 2013].
- Green Building Store 2009. Passivhaus project reveals flaws in Code [Online]. Available at: <http://www.greenbuildingstore.co.uk/news--passivhaus-code-for-sustainable-homes.html> [Accessed: 14 March 2013].
- Greenspace Live Ltd 2012. Introducing---gTools [Online]. Available at: <https://greenspacelive.com/web/gsl/products> [Accessed: 14 June 2013].
- Grilo, A. and Jardim-Goncalves, R. 2010. Value proposition on interoperability of BIM and collaborative working environments. *Automation in Construction* 19(5), pp. 522–530.
- Haas, W.R. 2000. STEP and its application in the construction industry. In: Goncalves, R., Steiger-Garcia, A., and Scherer, R. eds. *Product and process modelling in building and construction: proceedings of the third European Conference on Product and Process Modelling in the Building and Construction*. Rotterdam: A.A. Balkema.
- Healy, J. 2003. Fuel Poverty and Policy in Ireland and the European Union. *Studies in Public Policy* 12, pp. 1–169.
- Hitchcock, R.J. and Wong, J. 2011. Transforming IFC architectural view BIMS for energy simulation. In: *Proceedings of Building Simulation 2011*. Sydney, pp. 1089–1095.
- HKGBC 2013. The Hong Kong Green Building Council (HKGBC) 香港綠色建築議會 - BEAM Plus Project Directory [Online]. Available at: <http://www.hkgbc.org.hk/eng/BeamPlusDirectory.aspx> [Accessed: 4 June 2013].
- Holzinger, A. 2005. Usability engineering methods for software developers. *Communications of the ACM* 48(1), pp. 71–74.
- Hopfe, C.J., Augenbroe, F., Hensen, J., Wijsman, A. and Plokker, W. 2009. The impact of future climate scenarios on decision making in building performance simulation: a case study. In: *The 12th EuroPIA international conference*. Paris, France.
- Hopfe, C.J. and McLeod, R.S. 2010. *Passivhaus TFA - Dwellings*. PassivHausUK.
- Hopfe, C.J., Struck, C., Harputlugil, G.U., Hensen, J. and De Wilde, P. 2005. Exploration of the use of building performance simulation for conceptual design. In: *IBPSA-NVL Conference*. pp. 1–16.
- Howard, R. and Björk, B.-C. 2008. Building Information Modelling – Experts' views on standardisation and industry deployment. *Advanced Engineering Informatics* 22(2), pp. 271–280.



- Howell, I. and Batcheler, B. 2005. Building Information Modeling two years later—huge potential, some success and several limitations. *The Laiserin Letter* 22.
- IAI 1999. *IFC Object Model Architecture Guide*. International Alliance for Interoperability.
- Ibrahim, M. and Krawczyk, R. 2003. The level of knowledge of CAD objects within the building information model. In: *Association for Computer-Aided Design in Architecture Conference*. Muncie, IN, USA, pp. 173–177.
- IES 2009. New Connection Between ArchiCAD and IES [Online]. Available at: [http://www.iesve.com/news/new-connection-between-archicad-and-ies\\_1559\\_/corporate](http://www.iesve.com/news/new-connection-between-archicad-and-ies_1559_/corporate) [Accessed: 12 April 2012].
- Ilal, M.E. and Macit, S. 2007. Integration of an Acoustic Simulation Tool with CAAD Environments using ifcXML - Springer. In: *Enterprise Interoperability II*. pp. 807–810.
- Inbuilt 2010. *BREEAM versus LEED*.
- IPCC 2007. *IPCC Fourth Assessment Report: Climate Change 2007 (AR4)*.
- iPHA 2013a. International Passive House Association [Online]. Available at: [http://www.passivehouse-international.org/index.php?page\\_id=65](http://www.passivehouse-international.org/index.php?page_id=65) [Accessed: 12 March 2013].
- iPHA 2013b. Map of Certified Passive House Buildings [Online]. Available at: [http://www.passivehouse-international.org/index.php?page\\_id=288](http://www.passivehouse-international.org/index.php?page_id=288) [Accessed: 20 June 2013].
- iPHA 2012a. Passive House [Online]. Available at: [http://passiv.de/en/02\\_informations/01\\_whatisapassivehouse/01\\_whatisapassivehouse.htm](http://passiv.de/en/02_informations/01_whatisapassivehouse/01_whatisapassivehouse.htm) [Accessed: 5 June 2013].
- iPHA 2012b. Passivhaus Building Database [Online]. Available at: <http://www.passivhausprojekte.de/projekte.php?detail=1849&keyword=Larch%20House2012> [Accessed: 29 January 2013].
- Isikdag, U. and Underwood, J. 2010. Two design patterns for facilitating Building Information Model-based synchronous collaboration. *Automation in Construction* 19(5), pp. 544–553.
- ISO 2010. *BS EN ISO 9241-210:2010. Ergonomics of human-system interaction*. Geneva: International Standards Organisation.
- JaGBC 2013. CASBEE [Online]. Available at: <http://www.ibec.or.jp/CASBEE/english/> [Accessed: 4 June 2013].
- Jenkins, D., Patidar, S., Banfill, P.F.G. and Gibson, G.J. 2011. Probabilistic climate projections with dynamic building simulation: predicting overheating in dwellings. *Energy and Buildings* 43(7), pp. 1723–1731.
- Jenkins, G.J., Perry, M. and Prior, J. 2009. *The climate of the United Kingdom and recent trends*. Exeter: Met Office Hadley Centre.
- Jiri Hietanen 2011. *Nordic Energy (subset of Concept Design BIM 2010) - IFC 2x3 Binding Concepts Model*. US GSA/Statsbygg/Senate.
- Jung, Y. and Joo, M. 2011. Building Information Modelling (BIM) framework for practical implementation. *Automation in Construction* 20(2).
- Kachmar, S.J. 2009. B.I.M. TIMES: Autodesk Labs Ecotect analysis Revit Plug in [Online]. Available at: <http://bimtimes.blogspot.co.uk/2009/07/autodesk-labs-ecotect-analysis-revit.html> [Accessed: 23 March 2013].
- Kaner, I., Sacks, R., Kassian, W. and Quitt, T. 2008. Case Studies of BIM adoption for Precast Concrete Design by Mid-sized Structural Engineering Firms. *Journal of Information Technology in Construction* 13(Special Issue Case studies of BIM use), pp. 303–323.
- Kanton Zurich 2013. Liste zertifizierter EDV-Programme für SIA 380/1 (Ausgabe 2009) [Online]. Available at: [http://www.awel.zh.ch/internet/baudirektion/awel/de/energie\\_radioaktive\\_abfuelle/energienachweis/sia\\_308\\_1\\_thermischeenergieimhochbau/\\_jcr\\_conten](http://www.awel.zh.ch/internet/baudirektion/awel/de/energie_radioaktive_abfuelle/energienachweis/sia_308_1_thermischeenergieimhochbau/_jcr_conten)

- t/contentPar/downloadlist\_0/downloaditems/52\_1339421269557.spooler.download.1340787265976.xls/SIA+380-1+Liste\_d\_06\_2012.xls.
- Karavan, A., Neugebauer, M. and Kabitzsch, K. 2005. Merging building automation network design and IFC 2x construction projects. In: *22nd Conference on Information Technology in Construction. Dresden, Germany*. p. 21.
- Karlsruhe Institute of Technology 2012. Semantic Data Models [Online]. Available at: <http://www.iai.fzk.de/www-extern/index.php?id=1134&L=1> [Accessed: 3 October 2012].
- Khanzode, A., Fischer, M. and Reed, D. 2008. Benefits and lessons learned of implementing building virtual design and construction (VDC) technologies for coordination of mechanical, electrical, and plumbing (MEP) systems on a large healthcare project. *Journal of Information Technology in Construction* 13(Special Issue Case Studies of BIM use), pp. 324–342.
- Khemlani, L. 2005. CORENET e-PlanCheck: Singapore's Automated Code Checking System [Online]. Available at: <http://www.aecbytes.com/buildingthefuture/2005/CORENETePlanCheck.html> [Accessed: 16 June 2013].
- Kibert, C.J. 2013. *Sustainable Construction: Green Building Design and Delivery*. Third. Hoboken, New Jersey: John Wiley & Sons. Inc.
- Kim, H. and Anderson, K. 2013. Energy Modeling System Using Building Information Modeling (BIM) Open Standards. *Journal of Computing in Civil Engineering* 27(3). Available at: <http://ascelibrary.org/doi/abs/10.1061/%28ASCE%29CP.1943-5487.0000215> [Accessed: 22 March 2013].
- Kumar, J.V. and Mukherjee, M. 2009. Scope of Building Information Modeling (BIM) in India. *Journal of Engineering Science and Technology Review* 2(1), pp. 165–169.
- Laakso, M. and Kiviniemi, A. 2012. The IFC standard-a review of history, development, and standardization. *Journal of Information Technology in Construction*. Available at: <https://helda.helsinki.fi/handle/10138/36870> [Accessed: 9 June 2013].
- Lee, S.-H. and Kim, B.-G. 2011. IFC Extension for Road Structures and Digital Modeling. In: *The Twelfth East Asia-Pacific Conference on Structural Engineering and Construction*. Procedia Engineering, pp. 1037–1042.
- Lee, W.L. 2013. A comprehensive review of metrics of building environmental assessment schemes. *Energy and Buildings* 62, pp. 403–413.
- Lee, W.L. and Burnett, J. 2008. Benchmarking energy use assessment of HK-BEAM, BREEAM and LEED. *Building and Environment* 43(11), pp. 1882–1891.
- Liebich, T. 2012. IFC Extension Projects [Online]. Available at: [http://www.buildingsmart-tech.org/future-extensions/ifc\\_extension\\_projects](http://www.buildingsmart-tech.org/future-extensions/ifc_extension_projects) [Accessed: 20 March 2013].
- Liebich, T. 2009. IFC2x Model Implementation Guide. . Available at: <http://www.buildingsmart-tech.org/downloads/accompanying-documents/guidelines/IFC2x%20Model%20Implementation%20Guide%20V2-0b.pdf>.
- Liebich, T., Adachi, Y., Forester, J., Hyvarinen, J., Karstila, K., Reed, K., Richter, S. and Wix, J. 2007. IFC2x3 TC1 Documentation [Online]. Available at: <http://www.buildingsmart-tech.org/ifc/IFC2x3/TC1/html/index.htm> [Accessed: 25 September 2012].
- Liebich, T. and Wix, J. 1999. Highlights of the development process of industry foundation classes. In: *Proceedings of the 1999 CIB W78 Conference*. p. 18.
- Ma, Z. and Wang, S. 2009. Building energy research in Hong Kong: A review. *Renewable and Sustainable Energy Reviews* 13(8), pp. 1870–1883.

- Malin, N. 2007. Building Information Modeling and Green Design. *Environmental Building News* 16(5). Available at: <http://www.buildinggreen.com/auth/article.cfm/2007/5/1/Building-Information-Modeling-and-Green-Design/> [Accessed: 26 September 2011].
- Malloy, I. 2013. Vasari and Ecotect - Autodesk Vasari [Online]. Available at: <http://autodeskvasari.com/forum/topics/vasari-and-ecotect> [Accessed: 23 March 2013].
- McGraw Hill Construction 2010a. *Green BIM. How Building Information Modeling is Contributing to Green Design and Construction*.
- McGraw Hill Construction 2010b. *The Business Value of BIM in Europe*.
- McGraw Hill Construction 2012. The Business Value of BIM in North America. Multi-Year Trend Analysis and User Ratings (2007-2012) [Online]. Available at: <https://analyticsstore.construction.com/index.php/downloadable/download/link/id/MC41NjUzNzlwMCAxMzcxNzE0MTM5OTM0Mjk0ODA1OTI4MA,,/> [Accessed: 8 June 2013].
- McLeod, R.S., Hopfe, C.J. and Rezgui, Y. 2012a. A proposed method for generating high resolution current and future climate data for Passivhaus design. *Energy and Buildings* 55, pp. 481–493.
- McLeod, R.S., Hopfe, C.J. and Rezgui, Y. 2012b. An investigation into recent proposals for a revised definition of zero carbon homes in the UK. *Energy Policy* 46, pp. 25–35.
- McManus, A., Gaterell, M.R. and Coates, L.E. 2010. The potential of the Code for Sustainable Homes to deliver genuine ‘sustainable energy’ in the UK social housing sector. *Energy Policy* 38(4), pp. 2013–2019.
- Meteotest 2013. Meteonorm [Online]. Available at: <http://meteonorm.com/> [Accessed: 18 April 2012].
- Microsoft Corp. 2012. Export XML data [Online]. Available at: <http://office.microsoft.com/en-us/excel-help/export-xml-data-HP010206401.aspx> [Accessed: 25 April 2012].
- MINERGIE 2013. List of buildings [Online]. Available at: <http://www.minergie.ch/list-of-buildings.html> [Accessed: 2 June 2013].
- Moon, H.J., Choi, M.S., Kim, S.K. and Ryu, S.H. 2011. Case studies for the evaluation of interoperability between a BIM based architectural model and building performance analysis programs. In: *Proceedings of 12th Conference of International Building Performance Simulation Association*. pp. 1521–1526.
- Motamedi, A., Saini, R., Hammad, A. and Zhu, B. 2011. Role-based access to facilities lifecycle information on RFID tags. *Advanced Engineering Informatics* 25(3), pp. 559–568.
- NBS 2013. *NBS National BIM Report 2013*.
- Nepal, M.P., Staub-French, S., Pottinger, R. and Webster, A. 2012. Querying a building information model for construction-specific spatial information. *Advanced Engineering Informatics* 26(4), pp. 904–923.
- Newsham, G.R., Mancini, S. and Birt, B.J. 2009. Do LEED-certified buildings save energy? Yes, but.... *Energy and Buildings* 41(8), pp. 897–905.
- NIBS 2007. *United States National Building Information Modeling Standard. Version 1-Part 1: Overview, principles and Methodologies*.
- Nielsen, J. 2012. How Many Test Users in a Usability Study? [Online]. Available at: <http://www.nngroup.com/articles/how-many-test-users/> [Accessed: 23 June 2013].
- Nielson, J. 2012. Usability 101: Introduction to Usability [Online]. Available at: <http://www.nngroup.com/articles/usability-101-introduction-to-usability/> [Accessed: 22 June 2013].
- Nielson, J. 1993. *Usability Engineering*. Cambridge, MA: Academic Press.

- Nisbet, N. 2011. Standards in construction [Online]. Available at: <http://www.thenbs.com/topics/bim/articles/standardsInConstruction.asp> [Accessed: 10 June 2013].
- Nisbet, N. and Liebich, T. 2007. *ifcXML Implementation Guide*. buildingSMART International Ltd.
- Nispana 2013. Building Information Modeling - India 2013 [Online]. Available at: <http://www.bim-ind.com/> [Accessed: 8 June 2013].
- O'Donnell, J., See, R., Rose, C., Maile, T., Bazjanac, V. and Haves, P. 2011. SimModel: A domain data model for whole building energy simulation. In: *Proceedings of Building Simulation 2011*. pp. 382–389.
- O'Neill, S.J., Boykoff, M., Niemeyer, S. and Day, S.A. 2013. On the use of imagery for climate change engagement. *Global Environmental Change* 23(2), pp. 413–421.
- Oates, B. 2006. *Researching Information Systems and Computing*. London: Sage Publications.
- OCCS Development Committee Secretariat 2013. OmniClass [Online]. Available at: <http://www.omniclass.org/> [Accessed: 11 June 2013].
- OeJ 2010. *The MINERGIE -standard for buildings*. MINERGIE.
- Olive, J. 2003. *Maths: A Student's Survival Guide*. Cambridge, United Kingdom: Cambridge University Press.
- Open IFC Tools 2012. Open IFC Tools [Online]. Available at: <http://www.openifctools.org/> [Accessed: 18 April 2012].
- Osello, A., Cangialosi, G., Dalmaso, D., Di Paolo, A., Turco, M.L., Piumatti, P. and Vozzola, M. 2011. Architecture data and energy efficiency simulations: BIM and interoperability standards. In: *Proceedings of Building Simulation 2011*. Sydney, pp. 1521–1526.
- Ozok, A.A. 2012. Survey design and implementation in HCI. In: Jacko, J. ed. *The Human Computer Interaction Handbook*. Third Edition. Boca Raton, FL: CRC Press, pp. 1259–1277.
- Parker, J.M. 2009. Passivhaus in the Context of the Code for Sustainable Homes. UK: University of Huddersfield.
- Passive House Institute 1998. *Energiebilanzen mit dem Passivhaus Projektierungs Paket (Energy balances using the Passive House Planning Package)*. Darmstadt.
- PHI 2007. *Passive House Planning Package 2007*.
- Pickering, M. 2012. BIM Energy Analysis with ArchiCAD 16. . Available at: <http://emuarchitects.com/2012/05/18/bim-energy-analysis-with-archicad-16/> [Accessed: 17 January 2013].
- Plume, J. and Mitchell, J. 2007. Collaborative design using a shared IFC building model—Learning from experience. *Automation in Construction* 16(1), pp. 28–36.
- Preece, J., Rogers, Y., Sharp, H., Benyon, D., Holland, S. and Carey, T. 1994. *Human Computer Interaction*. Reading, Massachusetts: Addison Wesley.
- Progman Oy 2013a. MagiCAD [Online]. Available at: <http://www.magicad.com/en> [Accessed: 26 September 2013].
- Progman Oy 2013b. MagiCAD Comfort & Energy for energy calculations [Online]. Available at: <http://www.magicad.com/en/content/magicad-comfort-energy-energy-calculations> [Accessed: 13 June 2013].
- Quesenbery, W. 2008. Choosing the right usability technique: Getting the answers you need. In: *User Friendly*. Shenzhen, China.
- Quesenbury, W. 2001. What Does Usability Mean: Looking Beyond 'Ease of Use'. In: *Proceedings of the 48th Annual Conference, Society for Technical Communication*. Arlington, VA.

- Radhi, H. 2009. Evaluating the potential impact of global warming on the UAE residential buildings-A contribution to reduce the CO<sub>2</sub> emissions. *Building and Environment* 44(12), pp. 2451–2462.
- Rezgui, Y., Cemesova, A. and Hopfe, C.J. 2010. Building Systems Modeling and Design Challenges. *Encyclopedia of Life Support Systems*. Available at: <http://www.eolss.net/Sample-Chapters/C15/E1-32-25-00.pdf> [Accessed: 22 November 2011].
- RICS 2013. *RICS BIM Survey Results*.
- Robine, J.-M., Cheung, S.L.K., Le Roy, S., Van Oyen, H., Griffiths, C., Michel, J.-P. and Herrmann, F.R. 2008. Death toll exceeded 70,000 in Europe during the summer of 2003. *Comptes Rendus Biologies* 331(2), pp. 171–178.
- Roderick, Y., McEwan, D., Wheatley, C. and Alonso, C. 2009. Comparison of energy performance assessment between LEED, BREEAM and Green Star. In: *Eleventh International IBPSA Conference, Glasgow, Scotland, 27-30 July 2009*. pp. 1167–76.
- Rodrigues, L., Garratt, T. and Ebbs, N. 2012. Is added sustainability equal to added value? *Energy Conversion and Management* 63, pp. 203–207.
- Saniuk, I. 2011. Review of global environmental assessment methods [Online]. Available at: <http://www.bsria.co.uk/news/article/global-env-assess/> [Accessed: 3 June 2013].
- Sauer, J., Seibel, K. and Rüttinger, B. 2010. The influence of user expertise and prototype fidelity in usability tests. *Applied Ergonomics* 41(1), pp. 130–140.
- Saunders, T. 2008. A discussion document comparing international environmental assessment methods for buildings. *BRE, March*. Available at: [http://www.dgbc.nl/images/uploads/rapport\\_vergelijking.pdf](http://www.dgbc.nl/images/uploads/rapport_vergelijking.pdf) [Accessed: 4 June 2013].
- Scheer, D. 2013. Advanced Energy Analysis with Green Building Studio DOE2 and EnergyPlus support - Building Performance Analysis [Online]. Available at: <http://autodesk.typepad.com/bpa/2013/03/advanced-energy-analysis-with-green-building-studio-doe2-and-energyplus-support.html> [Accessed: 23 March 2013].
- Schevers, H. and Drogemuller, R. 2005. Converting the Industry Foundation Classes to the Web Ontology Language. In: *the First International Conference on Semantics, Knowledge, and Grid*. Beijing, China, pp. 73–75.
- Schlueter, A. and Thesseling, F. 2009. Building information model based energy/exergy performance assessment in early design stages. *Automation in Construction* 18(2), pp. 153–163.
- Schneider, P.J. and Eberly, D.H. 2003. *Geometric Tools for Computer Graphics*. San Fransisco,CA: Elsevier Science.
- Schnieders, J. and Hermelink, A. 2006. CEPHEUS results: measurements and occupants' satisfaction provide evidence for Passive Houses being an option for sustainable building. *Energy Policy* 34(2), pp. 151–171.
- Schwartz, Y. and Raslan, R. 2013. Variations in results of building energy simulation tools, and their impact on BREEAM and LEED ratings: A case study. *Energy and Buildings* 62, pp. 350–359.
- See, R., Haves, P., Sreekanthan, P., O'Donnell, J., Basarkar, M. and Settlemyre, K. 2011. Development of a user interface for the EnergyPlus whole building energy simulation program. In: *Building Simulation 2011: 12th Conference of International Building Performance Association*. Sydney, pp. 2919–2926.
- Senate Properties / Statsbygg 2011a. *NOW-001 Testing Results (IDA Indoor Climate and Energy 4 Expert edition)*.
- Senate Properties / Statsbygg 2011b. *NOW-001 Testing Results (RIUSKA)*.
- Serror, M.H., Inoue, J., Adachi, Y. and Fujino, Y. 2008. Shared computer-aided structural design model for construction industry (infrastructure). *Computer-Aided Design* 40(7), pp. 778–788.

- Sinclair, D. 2012. *BIM Overlay to the RIBA Outline Plan of Work*. RIBA.
- Sinclair, D. ed. 2013. *Riba Plan of Work 2013*. London: RIBA.
- Singh, V., Gu, N. and Wang, X. 2011. A theoretical framework of a BIM-based multi-disciplinary collaboration platform. *Automation in Construction* 20(2), pp. 134–144.
- Skripac, B. 2011. *BIM for Advanced Daylighting*. Autodesk University.
- Smith, D.K. and Tardif, M. 2009. *Building Information Modeling: a strategic implementation guide*. Hoboken, New Jersey: John Wiley & Sons. Inc.
- Sokolov, I. and Crosby, J. 2011. Utilizing gbXML with AECOsim Building Designer and speedikon.
- Spool, J. and Schroeder, W. 2001. Testing web sites: Five users is nowhere near enough. In: *CHI'01 extended abstracts on Human factors in computing systems*. pp. 285–286.
- Steel, J., Drogemuller, R. and Toth, B. 2012. Model interoperability in building information modelling. *Software and Systems Modelling* 11(1), pp. 99–109.
- STEP Tools Inc. 2013. AP 225 -- Building Elements [Online]. Available at: [http://www.steptools.com/support/stdev\\_docs/express/ap225/](http://www.steptools.com/support/stdev_docs/express/ap225/) [Accessed: 19 March 2013].
- Struck, C. 2012. Uncertainty propagation and sensitivity analysis techniques in building performance simulation to support conceptual building and system design. Technische Universiteit Eindhoven.
- SurveyMonkey 2013. SurveyMonkey [Online]. Available at: [http://www.surveymonkey.com/mp/lp/createsurveys/?utm\\_network=g&utm\\_term=survey+monkey&utm\\_campaign=e&gclid=CIPv89jf7bcCFdHMTAod1CwA0A&pmt=e&utm\\_source=adwords&mkwid=sJnar23mb&utm\\_medium=ppc&source=SearchNetwork&cmpid=brand&pcrid=31972368716&kw=survey+monkey](http://www.surveymonkey.com/mp/lp/createsurveys/?utm_network=g&utm_term=survey+monkey&utm_campaign=e&gclid=CIPv89jf7bcCFdHMTAod1CwA0A&pmt=e&utm_source=adwords&mkwid=sJnar23mb&utm_medium=ppc&source=SearchNetwork&cmpid=brand&pcrid=31972368716&kw=survey+monkey) [Accessed: 18 June 2013].
- Taylor, J.E. and Bernstein, P.G. 2009. Paradigm Trajectories of Building Information Modelling Practice in Project Networks. *Journal of Management in Engineering* 25(2), pp. 69–76.
- Torrente, M.C.S., Prieto, A.B.M., Gutiérrez, D.A. and de Sagastegui, M.E.A. 2013. Sirius: A heuristic-based framework for measuring web usability adapted to the type of website. *Journal of Systems and Software* 86(3), pp. 649–663.
- Tullis, T., Fleischman, S., McNulty, M., Cianchette, C. and Bergel, M. 2002. An empirical comparison of lab and remote usability testing of web sites. In: *Usability Professionals Association Conference*.
- Tunncliffe, H. 2012. Going global: The universal appeal of Passivhaus [Online]. Available at: <http://www.architectsjournal.co.uk/home/isover-portal/going-global-the-universal-appeal-of-passivhaus/8625779.article> [Accessed: 2 June 2013].
- UK Parliament 2008. *Climate Change Act 2008*. The Stationary Office Limited.
- US GSA 2009. *AECOO-1 Testbed Information Delivery Manual (IDM) for Building Performance and Energy Analysis (BPEA) Thread*. Open Geospatial Consortium Inc.
- US GSA 2012. *GSA BIM Guide Series 5*.
- USGBC 2013a. *LEED 2009 for New Construction and Major Renovations*.
- USGBC 2013b. LEED for Homes [Online]. Available at: <http://www.usgbc.org/leed/homes> [Accessed: 5 June 2013].
- USGBC 2012. *Press Release: U.S. green building council announces the LEED program to recognise energy credits from BREEAM*. Washington, DC.
- Venugopal, M., Eastman, C., Sacks, R. and Teizer, J. 2012. Semantics of model views for information exchanges using the industry foundation class schema. *Advanced Engineering Informatics* 26(2), pp. 411–428.
- Versele, A., Breesch, H., Klein, R., Biesbroeck, B., Wauman, K., Langmans, J., Mlecnik, E. and Van Loon, S. 2009. Flowcharts and data models in

- commissioning Passive House concepts. In: *PassiveHouse Symposium 2009*. Brussels, Belgium.
- Vollaro, T. 2013. Autodesk Vasari [Online]. Available at: <http://autodeskvasari.com/VasariBeta2> [Accessed: 23 March 2013].
- Wawan Solihin 2010. *Modeling for IFC with AutoCAD Architecture*. Autodesk.
- WBCSD 2013. Transforming the Market: Energy Efficiency in Buildings [Online]. Available at: <http://www.wbcd.org/transformingthemarketeeb.aspx> [Accessed: 15 June 2013].
- Weise, M., Katranuschkov, P. and Scherer, R.J. 2000. A proposed extension of the IFC project model for structural systems. In: *Product and process modelling in building and construction: proceedings of the third European Conference on Product and Process Modelling in the Building and Related Industries, Lisbon, Portugal*. pp. 229–238.
- Weise, M., Liebich, T., See, R., Bazjanac, V., Laine, T. and Welle, B. 2011. *Implementation Guide: Space Boundaries for Energy Analysis*. US General Services Administration and Open Geospatial Consortium.
- Welle, B., Haymaker, J. and Rogers, Z. 2011. *ThermalOpt: A methodology for BIM-based Passive Thermal Multidisciplinary Design Optimization*. Centre for Integrated Facility Engineering.
- Wheatley, C. 2010. In Practice: linking Revit to IES [Online]. Available at: <http://blog.iesve.com/index.php/2010/03/24/in-practice-linking-revit-to-ies/> [Accessed: 23 March 2013].
- De Wilde, P. and Tian, W. 2012. Management of thermal performance risks in buildings subject to climate change. *Building and Environment* 55, pp. 167–177.
- De Wilde, P. and Tian, W. 2011. Towards probabilistic performance metrics for climate change impact studies. *Energy and Buildings* (43), pp. 3013–3018.
- Wilkins, C. and Kiviniemi, A. 2008. Engineering-centric BIM. *ASHRAE Journal* 50(12), pp. 44–48.
- Wing, E. 2009. *Revit Architecture 2010*. Indianapolis, Indiana: Wiley Publishing, Inc.
- Wix, J. and Liebich, T. 2009. Using constraints to validate and check building information models. In: *eWork and eBusiness in Architecture, Engineering and construction*. Nice, France, pp. 467–476.
- World Energy Council 2008. *Energy efficiency policies around the world: review and evaluation*. London: World Energy Council.
- Zero Carbon Hub 2009. *Defining A Fabric Energy Efficiency Standard for zero carbon homes*. Task Group Recommendations.
- Zhiliang, M., Zhenhua, W., Wu, S. and Zhe, L. 2011. Application and extension of the IFC standard in construction cost estimating for tendering in China. *Automation in Construction* 20(2).

## Appendix A IFC EXTENSION

Below is an EXPRESS-G diagram documenting the energy extension of the IFC. Items in grey are pre-existing concepts, and items in white are the extension.

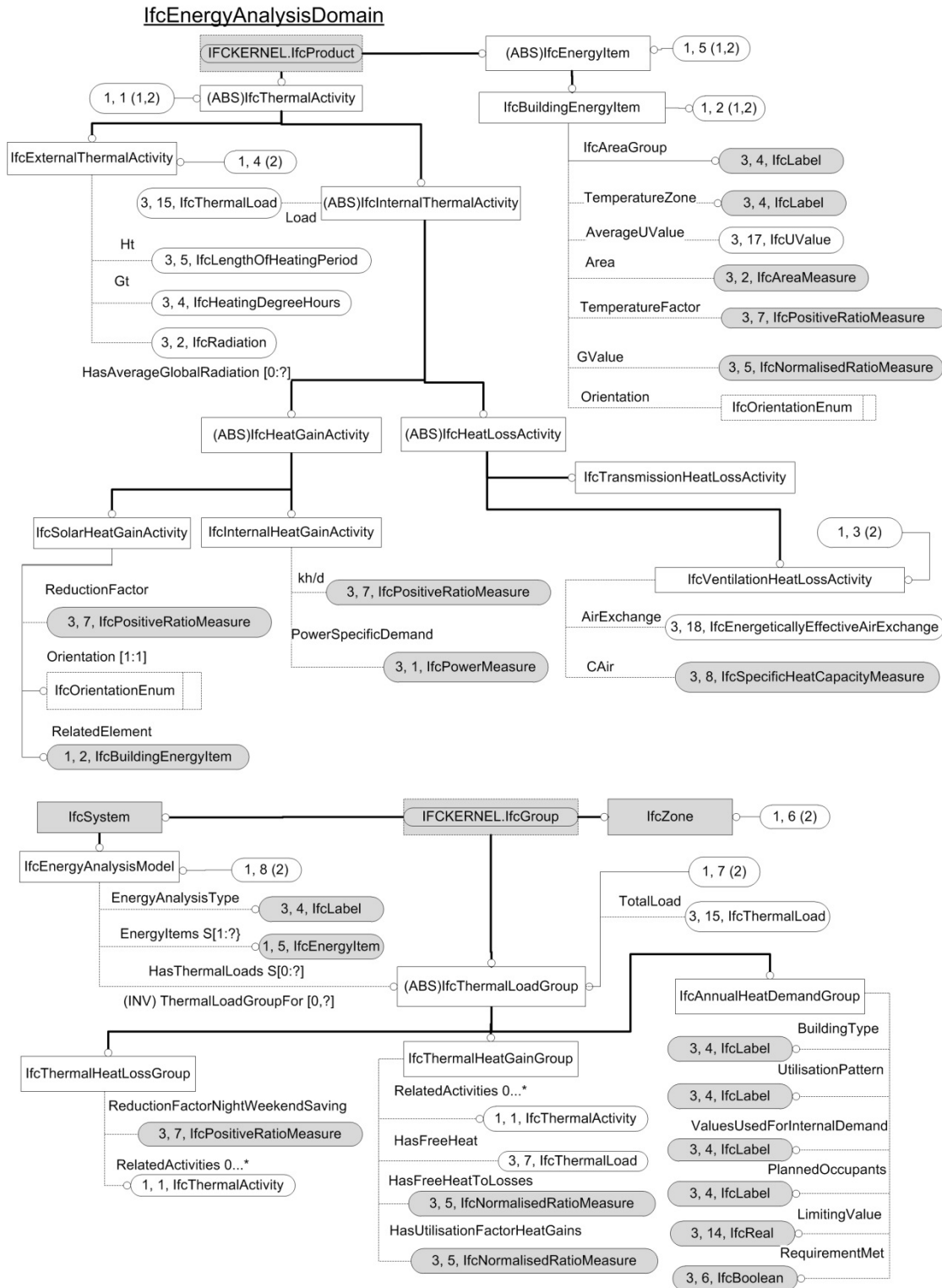


Figure A.1 IFC Energy Extension - Page 1



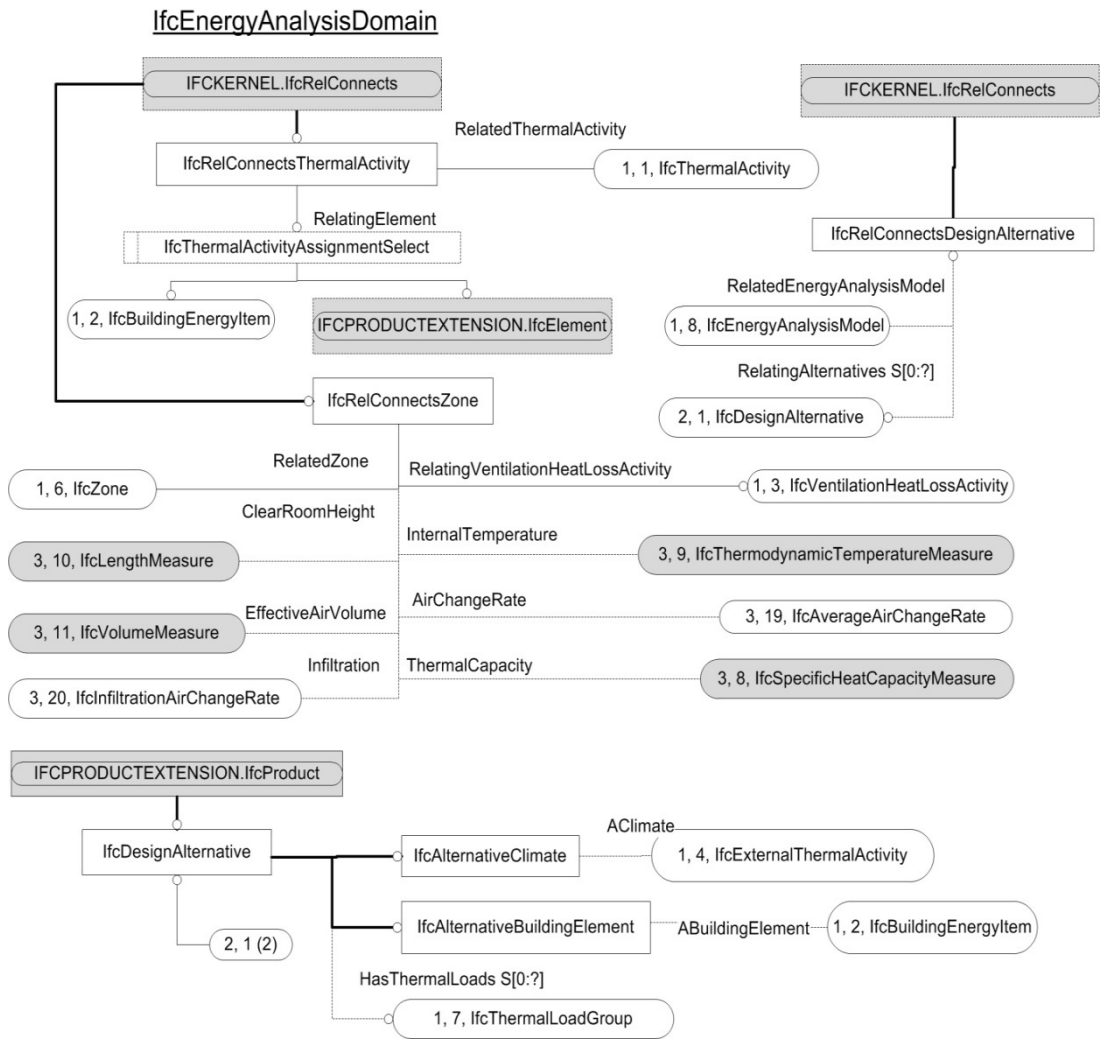


Figure A.2 IFC Energy Extension - Page 2

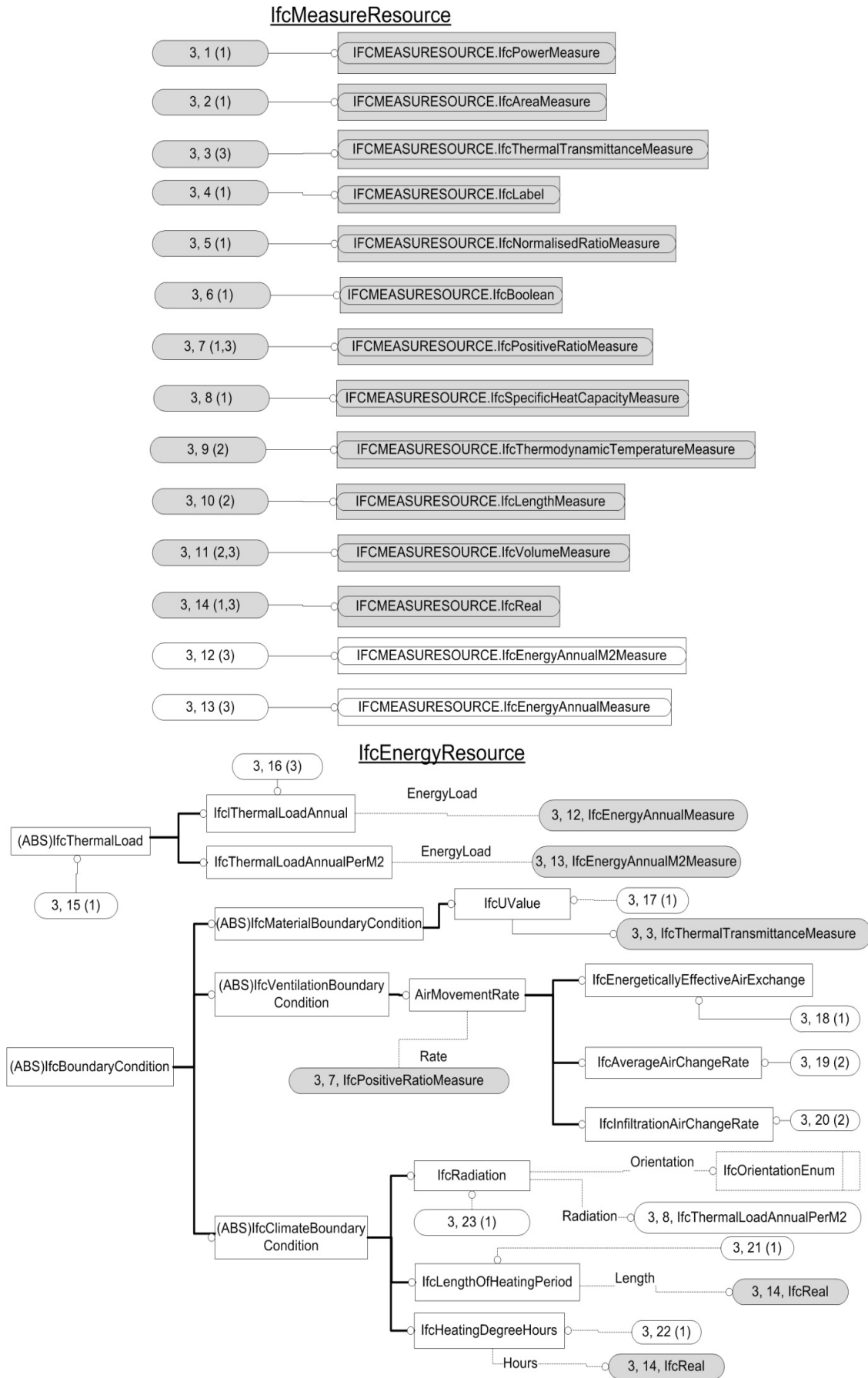


Figure A.3 IFC Energy Extension - Page 3

## Appendix B PROCESSING OF IFC GEOMETRY

### B.1 THE PLACEMENT AND REPRESENTATION OF IFCPRODUCT

The geometrical data needed to be extracted from an IFC file consists of building element areas and window orientations. In the IFC schema, data about building elements can be found in the *'IfcBuildingElement'* entity. This data is stored by both direct attributes and inherited attributes. The inherited attributes needed to calculate areas and orientations originate from its supertype, *'IfcProduct'*. These attributes describe where an object is placed and what its geometry is, and are called *'ObjectPlacement'* and *'Representation'* respectively.

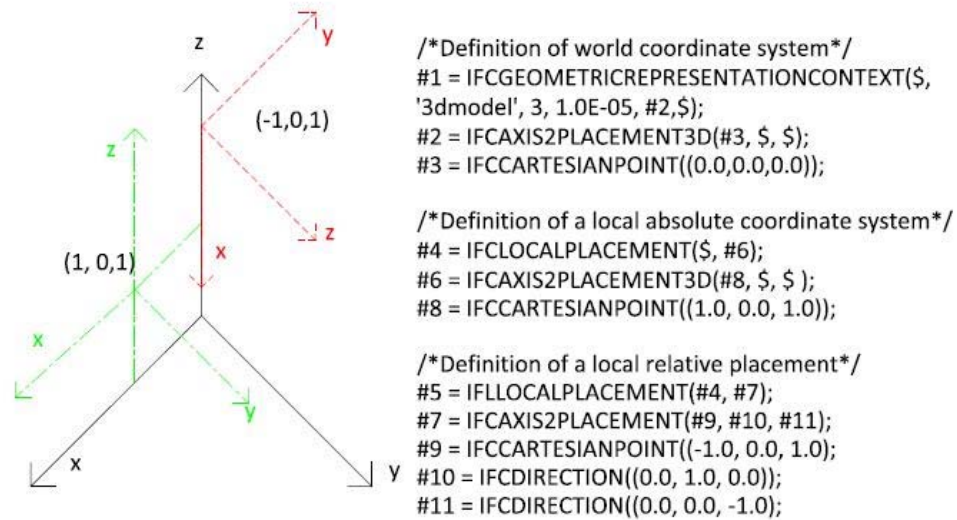
The *'Representation'* attribute can be filled by an *'IfcProductRepresentation'* and its subtypes. One of its subtypes is the *'IfcProductDefinitionShape'* and it is used to describe the geometric shape of an *'IfcProduct'*. It can contain many different types of shape representations. These are described by the entity *'IfcShapeRepresentation'*. For a building element such as a wall, these could range from a wall path *'Curve2D'* to a wall body *'SweptSolid'*. A wall body description generally describes the extruded shape and if/how it is clipped, and areas can be calculated from this. A wall path is just the centreline of a wall. These areas still have to be adjusted in some cases in order to represent the full external thermal envelope. An example of this is the insulation could be in either the roof, or above the highest ceiling. This would change what area of the described wall is in the thermal envelope. The areas of building elements can also be taken straight from quantity sets. However, the use of quantity sets is avoided in this project as:

- They are not part of the main IFC schema specification and therefore their definition could change at any point.
- They are not automatically generated in tools such as Revit so could be missing.
- They are just areas for the whole wall, whilst PHPP needs the thermal envelope external area. If the thermal envelope ends at the top of the highest floor, the walls representation attribute would have to be relied upon anyway to provide information on the walls geometry and where the ceiling cuts the wall.

The key reason for using information from the *'Placement'* attribute is it contains data which can be used to determine the orientation of a building element. The *'ObjectPlacement'* attribute can be filled by the abstract entity *'IfcObjectPlacement'* and all its subtypes. One of the common subtypes of the *'IfcObjectPlacement'* is the *'IfcLocalPlacement'*. The latter has two attributes, *'PlacementRelTo'* and *'RelativePlacement'*. In an IFC project, there is one world coordinate system, and many local coordinate systems. The *'PlacementRelTo'* can be absolute, or relative to another local placement. Some entities placements are constrained by rules (Liebich 2009):

- *'IfcSite'* is placed absolutely within the world coordinate system (WCS).
- *'IfcBuilding'* is placed relative to the *'IfcSite'*.
- *'IfcBuildingStorey'* is placed relative to the *'IfcBuilding'*.
- *'IfcElement'* is placed relative to either the local placement of a container such as the *'IfcBuildingStorey'*, or to another *'IfcElement'* to which it has a relationship.

The *'RelativePlacement'* attribute is filled by the select type *'IfcAxisToPlacement'*. When related to 3D objects, the *'IfcAxis2Placement3D'* entity is selected. This entity has three attributes, *'Location'*, *'Axis'* and *'RefDirection'*. It relates the transformation of the coordinate system from a relative placement to a point, which will be the origin of a new coordinate system. This transformation is composed of two parts: a translation and rotation. The *'Location'* attribute is filled by the entity *'IfcCartesianPoint'*, and forms the translation part of the transformation. It describes the location of a point which is the origin to the new coordinate system. The *'Axis'* attribute describes the direction of the z-axis of this new coordinate system, and the *'RefDirection'* describes the direction of the x-axis of the new coordinate system. Figure B.1 shows a selection of coordinate systems and an example of code which would describe those coordinate systems. The entity labelled '#2' is an absolute placement to the WCS: it has a location which is a Cartesian point, but no axis or *'RefDirection'*. The entity labelled '#7' does have the latter, and so is a local placement.



**Figure B.1 Different coordinate axis and their description if an IFC file**

The directions of the z- and x-axis are given in the form of 3D vectors, and the y-axis direction vector can be calculated based on the z- and x-axis using the principle of a cross product. The x, y and z vectors can be used to for the rotation part of the transformation. In order to transform points between the various coordinate systems, matrices can be used. The derivation of the transformation matrices which are used to switch between coordinate systems are described in the following section.

## B.2 TRANSFORMING POINTS AND COORDINATE SYSTEMS

Points in a 2D coordinate system can be translated into new positions by translation, rotation and scaling (Foley et al. 1996). The IFC file does not scale objects, so it will be ignored from this point on. The right hand coordinate axis convention is used in the IFC files, so will be used here as well.

When transforming a point  $P(x,y)$  using translation from an original position to a new position which will be point  $P'(x',y')$ , the points and translation amounts  $d_x$  and  $d_y$  in the x- and y-axis respectively can be described as column vectors

$$P = \begin{bmatrix} x \\ y \end{bmatrix}; \quad P' = \begin{bmatrix} x' \\ y' \end{bmatrix}; \quad T = \begin{bmatrix} d_x \\ d_y \end{bmatrix}. \quad \text{(Equation B.1)}$$

As a translation transformation simply adds  $d_x$  to the original x coordinate and  $d_y$  to the original y coordinate, translation of a 2D coordinate can be expressed as

$$P' = P + T \quad \text{(Equation B.2)}$$

According to Foley et al. (1996), the rotation of points by an angle 'θ' about the origin can be expressed as:

$$x' = x * \cos\theta - y * \sin\theta ; y' = x * \sin\theta + y * \cos\theta. \quad \text{(Equation B.3)}$$

This can be expressed in a matrix form as:

$$\begin{bmatrix} x' \\ y' \end{bmatrix} = \begin{bmatrix} \cos\theta & -\sin\theta \\ \sin\theta & \cos\theta \end{bmatrix} * \begin{bmatrix} x \\ y \end{bmatrix} \text{ or } P' = R * P, \quad \text{(Equation B.4)}$$

where R is the rotation matrix. The convention of positive angles being anticlockwise around an axis is used in this thesis.

In order to combine these transformations into a single matrix, the transformations ideally would be all consistent, i.e. all use multiplication as the operator. In order to be able to have both transformations performed by multiplication, points have to be in the form of homogenous coordinates (Foley et al. 1996). A homogenous coordinate adds an extra coordinate to a point, so the 2D point (x,y) becomes (x,y,W), and (x',y') becomes (x',y',W'). If W is non-zero, the other coordinates can be divided by it. A point therefore has several homogenous coordinate representations, for example (4, 6, 2) and (2,3,1) is the same point. This is called a homogenized coordinate. This can be written formally as:

$$(x, y, W) = (x/W, y/W, 1) \quad \text{(Equation B.5)}$$

When x and y are divided by W, x/W and y/W are called the '*Cartesian coordinates of the homogenous point*' (Foley et al. 1996). If all the homogenous representations of a point were plotted in a 3D space they would become a line. When a point is homogenized to (x/W, y/W, 1), it is simply being projected on the plane W=1 in a three dimensional space. If W is equal to 0, it is called a point at infinity and cannot be represented on this plane.

As 2D points are now in the form of 3x1 vectors, transformation matrices must be expanded to have three rows and columns. This can be done using the concept of an identity matrix, and the translations  $x' = x + d_x$ ,  $y' = y + d_y$  and  $z' = z + d_z$  can now be described using matrices as:

$$\begin{bmatrix} x' \\ y' \\ 1 \end{bmatrix} = \begin{bmatrix} 1 & 0 & d_x \\ 0 & 1 & d_y \\ 0 & 0 & 1 \end{bmatrix} * \begin{bmatrix} x \\ y \\ 1 \end{bmatrix}, \quad \text{which can also be expressed as } P' = T(dx,dy) * P. \quad \text{(Equation B.6)}$$

The transformation matrix which describes rotation R is also expanded to become a 3x3 matrix, and the transformation of one point to another can be described as:

$$\begin{bmatrix} x' \\ y' \\ 1 \end{bmatrix} = \begin{bmatrix} \cos\theta & -\sin\theta & 0 \\ \sin\theta & \cos\theta & 0 \\ 0 & 0 & 1 \end{bmatrix} * \begin{bmatrix} x \\ y \\ 1 \end{bmatrix}, \text{ which is the same as } P'=R(\theta)*P. \quad \text{(Equation B.7)}$$

2D transformations can be combined in a single transformation matrix. This process is called composition. The order of the composition is important, as it changes the outcome of the matrix. If a point is being translated and then rotated, the combined transformation matrix will have the form:

$$T(dx, dy) * R(\theta) = \begin{bmatrix} \cos\theta & -\sin\theta & d_x \\ \sin\theta & \cos\theta & d_y \\ 0 & 0 & 1 \end{bmatrix}. \quad \text{(Equation B.8)}$$

The rotations in the matrix (upper left) in Equation B.8 are can be said to be a 2x2 submatrix. If the two rows (or columns) of this submatrix are understood to be vectors, they can be proved to a) be unit vectors, b) be perpendicular to each other. The directions of the two vectors describe what direction the new x- and y-axis will be once they are rotated (Foley et al. 1996). A transformation matrix with these properties is called a special orthogonal. It is used to describe rigid body transformations as it preserves lengths and angles.

The principles above can also be extended to a 3D coordinate system. In order to be able to combine the transformations for three element points, homogenized coordinates have to be used. The point (x,y,z) becomes (x,y,z,W) and its homogenized form is (x/W, y/W, z/W, 1). The translation and rotation matrices will become 4x4 matrices to maintain compatibility with the homogenized coordinates, and the transformations are all consistent again. The transformation matrix M composed of any number of translations and rotations will always have the form:

$$M = \begin{bmatrix} r_{11} & r_{12} & r_{13} & d_x \\ r_{21} & r_{22} & r_{23} & d_y \\ r_{31} & r_{32} & r_{33} & d_z \\ 0 & 0 & 0 & 1 \end{bmatrix} \quad \text{and points will be translated} \\ \text{using the equation } P' = M*P \quad \text{(Equation B.9)}$$

The main difference is that there will be three rotation matrices available, as rotations can now occur around the x-, y- and z-axis. The 4x4 matrix which rotates a point around the z-axis  $R_z(\theta)$  is based on the matrix  $R(\theta)$  in Equation B.7 and becomes:

$$R_z(\theta) = \begin{bmatrix} \cos\theta & -\sin\theta & 0 & 0 \\ \sin\theta & \cos\theta & 0 & 0 \\ 0 & 0 & 1 & 0 \\ 0 & 0 & 0 & 1 \end{bmatrix} \quad \text{(Equation B.10)}$$

This means that the 3D version of Equation B.7 which rotates point P to P' becomes:

$$\begin{bmatrix} x' \\ y' \\ z' \\ 1 \end{bmatrix} = \begin{bmatrix} \cos\theta & -\sin\theta & 0 & 0 \\ \sin\theta & \cos\theta & 0 & 0 \\ 0 & 0 & 1 & 0 \\ 0 & 0 & 0 & 1 \end{bmatrix} * \begin{bmatrix} x \\ y \\ z \\ 1 \end{bmatrix} \quad \text{or} \quad P' = R_z(\theta) * P \quad \text{(Equation B.11)}$$

More details about the remaining rotation matrices can be found in (Foley et al. 1996), and they will not be explained here further. This is due to the IFC file giving the rotations in a format so they can be slotted into Equation B.9. Therefore, they are not used to create matrices around a single axis, like the rotation matrix in Equation B.10.

So far, the matrices above translate the position of a point in a single coordinate system. It is also possible to transform a point between two different coordinate systems. This occurs in IFC files, as objects are placed in a local coordinate system. The matrix used for this is the inverse to that used to manipulate a point in a single coordinate system. Figure B.2(a) shows a rotation of a homogenized point P(1,0,0,1) in a single coordinate system by 90 degrees around the z-axis. Using Equation B.11 this can be written as:

$$\begin{aligned} \begin{bmatrix} x' \\ y' \\ z' \\ 1 \end{bmatrix} &= \begin{bmatrix} \cos 90 & -\sin 90 & 0 & 0 \\ \sin 90 & \cos 90 & 0 & 0 \\ 0 & 0 & 1 & 0 \\ 0 & 0 & 0 & 1 \end{bmatrix} * \begin{bmatrix} 1 \\ 0 \\ 0 \\ 1 \end{bmatrix} = \begin{bmatrix} 0 & -1 & 0 & 0 \\ 1 & 0 & 0 & 0 \\ 0 & 0 & 1 & 0 \\ 0 & 0 & 0 & 1 \end{bmatrix} * \begin{bmatrix} 1 \\ 0 \\ 0 \\ 1 \end{bmatrix} \\ &= \begin{bmatrix} 0 \\ 1 \\ 0 \\ 1 \end{bmatrix} \end{aligned} \quad \text{(Equation B.12)}$$

Figure B.2 b) shows a rotation around the z-axis by 90° of coordinate system 'j' to become coordinate system 'i'. The notation for point P and P' from Equation B.11 becomes  $P_j$  and  $P_i$  respectively. The transformation is the same as in Equation B.12 (90 degrees around the z-axis), but representing a coordinate axis transformation. The matrix is therefore the inverse to Equation B.12, which can also be represented as a negative angle:

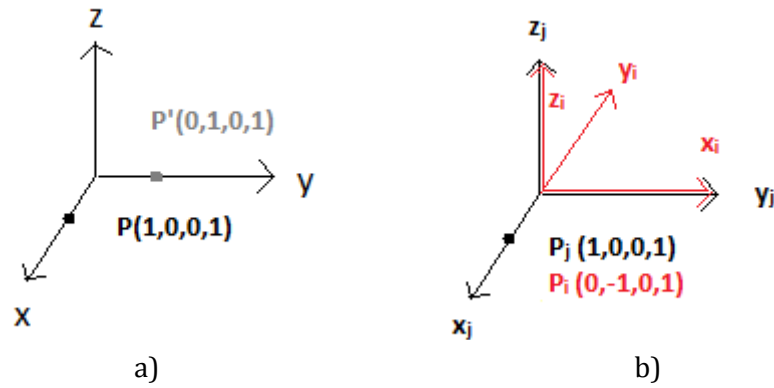


$$\begin{bmatrix} x_i \\ y_i \\ z_i \\ 1 \end{bmatrix} = \begin{bmatrix} \cos(-90) & -\sin(-90) & 0 & 0 \\ \sin(-90) & \cos(-90) & 0 & 0 \\ 0 & 0 & 1 & 0 \\ 0 & 0 & 0 & 1 \end{bmatrix} * \begin{bmatrix} 1 \\ 0 \\ 0 \\ 1 \end{bmatrix}$$

(Equation B.13)

$$= \begin{bmatrix} 0 & 1 & 0 & 0 \\ -1 & 0 & 0 & 0 \\ 0 & 0 & 1 & 0 \\ 0 & 0 & 0 & 1 \end{bmatrix} * \begin{bmatrix} 1 \\ 0 \\ 0 \\ 1 \end{bmatrix} = \begin{bmatrix} 0 \\ -1 \\ 0 \\ 1 \end{bmatrix}$$

It is important to note at this point that in Equation B.13, the matrices can be defined using either an angle of rotation around an axis or simply by vectors in the upper 3x3 submatrix.



**Figure B.2 a) Rotation of a point in a single coordinate system by 90° b) Same point in the coordinate system 'i' and 'j', where 'i' is defined as 'j' rotated by 90° around the z-axis.**

If a point is being transformed from coordinate system 'j' to coordinate system 'i', the matrix notation is  $M_{i \leftarrow j}$ . Therefore,  $P' = M * P$  from Equation B.9 can be written as:

$$P^{(i)} = M_{i \leftarrow j} * P^{(j)}. \quad \text{(Equation B.14)}$$

If transformations are being described between more than two coordinate systems, they can be composed into a single matrix. A matrix transforming points from coordinate system 'k' to 'j' and then to 'i' is represented as:

$$M_{i \leftarrow k} = M_{i \leftarrow j} * M_{j \leftarrow k}. \quad \text{(Equation B.15)}$$

Transformations can also be reversed by using the inverse of a matrix. The matrix which moves points from the coordinate system 'j' to 'i' is the inverse of the matrix which moves points from the coordinate system 'i' to 'j':

$$M_{i \leftarrow j} = M_{j \leftarrow i}^{-1} \quad \text{(Equation B.16)}$$

The geometry of an object in an IFC file is generally described relative to its local placement. This can be relative to other objects. For example, the wall geometry description will be based on in the wall coordinate system, which is relative to the building storey coordinate system, which is relative to the building coordinate system. The matrix which transforms points from the wall coordinate system to the building coordinate system would be composed following Equation B.15, and can be written as:

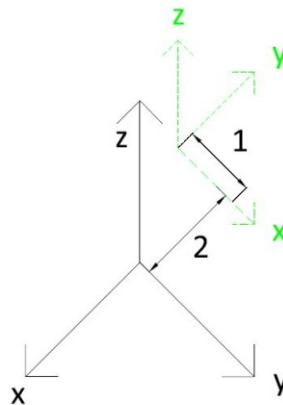
$$M_{building \leftarrow wall} = M_{building \leftarrow building\ storey} * M_{building\ storey \leftarrow wall} \quad \text{Equation B.17}$$

The matrix  $M_{building \leftarrow building\ storey}$  transforms coordinates from the building coordinate axes to the building storey coordinate axes. Similarly,  $M_{building\ storey \leftarrow wall}$  transforms coordinates from the wall coordinate system to the building storey coordinate system.

As mentioned briefly in the section B.1, the placement of an object which is relative to another coordinate system depends on the data in '*IfcAxis2Placement3D*' attributes. In order to construct a transformation matrix these attributes have to be found in an IFC file and processed to form a matrix in the form of Equation B.9. The '*Location*', attribute refers to an '*IfcCartesianPoint*', which will contain the translation amounts dx, dy and dz. These amounts can be inserted into the transformation matrix in Equation B.9, and the rest is left as an identity matrix. The '*Axis*' and '*RefDirection*' are represented by the entity '*IfcDirection*', and contain vectors which give the direction of the objects z- and x-axis respectively, in terms of the relative coordinate system. If the data was to be inserted into the transformation matrix in Equation B.9, '*Axis*' is  $r_{31}$ ,  $r_{32}$  and  $r_{33}$  and '*RefDirection*' is  $r_{11}$ ,  $r_{12}$  and  $r_{13}$ . The rest would be left as an identity matrix. However, in order to compose these two matrices into a single transformation, they have to be adjusted slightly.

A typical matrix generated in this project transforms points from '*IfcElement*' subtype coordinate systems to the '*IfcBuildingStorey*' coordinate system. Subtypes of the '*IfcElement*' are commonly used as it is an abstract entity so will never actually appear in an IFC file. In this case, translations could be used as they are stated in the IFC file. This is as they describe the transformation of a point from the '*IfcElement*' coordinate system to the '*IfcBuildingStorey*' system. For the rotations, the cross product of the z- and x-axis would have to be calculated first in order to

determine the direction vector for the y-axis. Then the x, y and z vectors would be slotted into the matrix in Equation B.9, with the y vector filling  $r_{21}$ ,  $r_{22}$  and  $r_{23}$ . The rotation matrix however transforms points from the '*IfcBuildingStorey*' coordinate system to the '*IfcElement*' coordinate system, so the inverse needs to be calculated. Now, the translation matrix is multiplied with the (inverted) rotation matrix to give a final transformation matrix which can transform points in the '*IfcElement*' coordinate system to the '*IfcBuildingStorey*' coordinate system. Figure B.3 shows an example of this where the '*IfcBuildingStorey*' coordinate system is translated by  $T(-2, -1, 0)$  and rotated by  $90^\circ$  around the z-axis to become the '*IfcElement*' coordinate system.



**Figure B.3** Translation and rotation of '*IfcBuildingStorey*' to '*IfcElement*' coordinate system.

The matrix which would transform points from '*IfcElement*' (IfcE) to '*IfcBuildingStorey*' (IfcBS) coordinate system is:

$$M_{IfcBS \leftarrow IfcE} = T(-2, -1, 0) * R_z(90)$$

$$= \begin{bmatrix} 1 & 0 & 0 & -2 \\ 0 & 1 & 0 & -1 \\ 0 & 0 & 1 & 0 \\ 0 & 0 & 0 & 1 \end{bmatrix} * \begin{bmatrix} \cos(90) & -\sin(90) & 0 & 0 \\ \sin(90) & \cos(90) & 0 & 0 \\ 0 & 0 & 1 & 0 \\ 0 & 0 & 0 & 1 \end{bmatrix}$$

(Equation B.18)

$$= \begin{bmatrix} \cos 90 & -\sin 90 & 0 & -2 \\ \sin 90 & \cos 90 & 0 & -1 \\ 0 & 0 & 1 & 0 \\ 0 & 0 & 0 & 1 \end{bmatrix}$$

$$= \begin{bmatrix} 0 & -1 & 0 & -2 \\ 1 & 0 & 0 & -1 \\ 0 & 0 & 1 & 0 \\ 0 & 0 & 0 & 1 \end{bmatrix}$$

Table B.1 holds values of the same point in both the IfcE and IfcBS coordinate systems, calculated using Equation B.14.

**Table B.1 A point in two different coordinate systems**

$P_{IfcBS}$	$P_{IfcE}$
(-2,-1,0)	(0,0,0)
(-2,0,0)	(1,0,0)
(-3,-1,0)	(0,1,0)
(X, Y, Z)	(y'-2, x'-1, z')

The value held in '*IfcCartesianPoint*' for the '*Location*' attribute of '*IfcAxisToPlacement*' would be (-2, -1, 0). This can also be written as ( $d_x$ ,  $d_y$ ,  $d_z$ ), and can be used directly to create the translation matrix in Equation B.18. This is done inserting the translation amounts  $d_x$ ,  $d_y$  and  $d_z$  into Equation B.9 to form the translation matrix:

$$T_{IfcBS \leftarrow IfcE} = \begin{bmatrix} 1 & 0 & 0 & d_x \\ 0 & 1 & 0 & d_y \\ 0 & 0 & 1 & d_z \\ 0 & 0 & 0 & 1 \end{bmatrix} = \begin{bmatrix} 1 & 0 & 0 & -2 \\ 0 & 1 & 0 & -1 \\ 0 & 0 & 1 & 0 \\ 0 & 0 & 0 & 1 \end{bmatrix}. \quad \text{(Equation B.19)}$$

The value of the '*Axis*' attribute of *IfcAxis2Placement* is (0,0,1) and for the '*RefDirection*' is (0,1,0). Using the notation from Equation B.9, these can also be written as ( $r_{31}$ ,  $r_{32}$ ,  $r_{33}$ ) and ( $r_{11}$ ,  $r_{12}$ ,  $r_{13}$ ) respectively. Using the principle of a cross product, the vector for the y-axis can be calculated as (-1, 0, 0). Using notation from Equation B.9, this is ( $r_{21}$ ,  $r_{22}$ ,  $r_{23}$ ). The initial rotation matrix can be built by inserting the rotation amounts into Equation B.9, and then inverting it:

$$R_{IfcBS \leftarrow IfcE} = \begin{bmatrix} r_{11} & r_{12} & r_{13} & 0 \\ r_{21} & r_{22} & r_{23} & 0 \\ r_{31} & r_{32} & r_{33} & 0 \\ 0 & 0 & 0 & 1 \end{bmatrix} = R_{IfcBS \leftarrow IfcE}^{-1} = \quad \text{(Equation B.20)}$$

$$\begin{bmatrix} 0 & 1 & 0 & 0 \\ -1 & 0 & 0 & 0 \\ 0 & 0 & 1 & 0 \\ 0 & 0 & 0 & 1 \end{bmatrix}^{-1} = \begin{bmatrix} 0 & -1 & 0 & 0 \\ 1 & 0 & 0 & 0 \\ 0 & 0 & 1 & 0 \\ 0 & 0 & 0 & 1 \end{bmatrix}.$$

Multiplying the resulting matrix in Equation B.19 by the matrix in Equation B.20 will give the same matrix as supplied by Equation B.18.

The matrix obtained in Equation B.20 will transform points from one coordinate system to another. In some cases in an IFC file, there may be a chain of relative placements. For example, all '*IfcElements*' is placed in the coordinate system of an '*IfcBuildingStorey*', which is placed in the coordinate system of an '*IfcBuilding*' etc. The process to derive a transformation matrix has to be done on each occurrence of '*IfcLocalPlacement*'. Each '*IfcLocalPlacement*' will firstly mention what it is further relatively placed to, and refer to a '*IfcAxisToPlacement3D*'.

### B.3 DETERMINING THERMAL ENVELOPE DIMENSIONS AND ORIENTATIONS

The equations and processes developed in the last section can be used in the following to determine external areas and orientations of different building elements. This section describes the process of extracting data for each element individually, as they tend to vary significantly.

#### B.3.1 EXTERNAL WALL AREA

In an IFC file, a wall can be either an *'IfcWall'* or an *'IfcWallStandardCase'* entity. The *'IfcWallStandardCase'* is more useful, as it holds more parametric information than the *'IfcWall'* (Wawan Solihin 2010). The *'IfcWall'* entity is mainly used for a wall which has a changing thickness along the wall path, and therefore has a different shape representation than the *'IfcWallStandardCase'*. It can be a *'SeptSolid'* which has a polygonal footprint, or a *'Brep'*. In the example given by (Liebich 2009), in its simplest form the *'Brep'* is a list of faces which are defined by coordinates. An *'IfcWallStandardCase'* is “*more desirable as a wall representation since it allows more parametric description of the wall that allows more intelligent data to be exchanged*” (Wawan Solihin 2010). An example of what is lost is the *'IfcMaterialLayerSetUsage'*, which is used for the determination of an orientation in this project. An *'IfcWall'* is also not handled by some existing tools, such as the IFCViewer of Karlsruhe Institute of Technology (Karlsruhe Institute of Technology 2012). Therefore, this type of wall is currently ignored by *'ExtractIfcGeometry'*.

The *'IfcWallStandardCase'* entity is processed by determining if it is external or internal, reasoning about its orientation and then calculating its area. The last part is dependent on the walls representation type.

##### B.3.1.1 Is it External?

An IFC model may contain internal and external walls. Only the exterior walls describe the thermal envelope, so the first step is to determine which walls are applicable. The *'IfcPropertySet'* entity has an attribute *'Name'* equal to *'Pset\_WallCommon'*, and it can be used for this purpose. One this property sets attributes refers to an *'IfcPropertySingleValue'* called *'IsExternal'*, which hold the value *'true'* or *'false'*. Whilst this is not a direct or inherited attribute to the *'IfcWall'* entity, it is mentioned in the IFC specification so it is assumed that most IFC files would include this property set.

The entity *'IfcRelDefinesByProperties'* links the property set *'Pset\_WallCommon'* to an instance of a wall. The entity *IfcRelDefinesByProperties* has the attributes *'RelatedObjects'*, and *'RelatingPropertyDefinition'*. The *'RelatedObjects'* attribute to

refers to a wall instance, and the *'RelatingPropertyDefinition'* attribute refers to property sets which describe the walls properties. Figure B.4 is an example of lines in an IFC file which would be processed to determine if a wall is external. It shows an *'IfcWallStandardCase'* instance with the id #20, and the property set *'IfcPropertySet'* with an id #21 and the *'Name'* attribute *'Pset\_WallCommon'*. These two entities are related by the entity *IfcRelDefinesByProperties* which has an id of #26. The *'IfcPropertySet'* has four entities in its *'HasProperties'* attribute, one of which is an *'IfcPropertySingleValue'* which has the *'Name'* attribute *'IsExternal'*.

```

...
#20= IFCWALLSTANDARDCASE ( '25$t42e8L7vQB9k3Wqe2Qb' , #52, 'Wall', $, 'Wall', #18, #19, '2' );
#21= IFCPROPERTYSINGLEVALUE( 'Reference' , $, IFCIDENTIFIER( 'LarchWallExternal' ), $ );
#22= IFCPROPERTYSINGLEVALUE( 'LoadBearing' , $, IFCBOOLEAN( .F. ), $ );
#23= IFCPROPERTYSINGLEVALUE( 'ExtendToStructure' , $, IFCBOOLEAN( .T. ), $ );
#24= IFCPROPERTYSINGLEVALUE( 'IsExternal' , $, IFCBOOLEAN( .T. ), $ );
#25=
IFCPROPERTYSET( '25$t42e8L7vQB9k3aqe2Qb' , #52, 'Pset_WallCommon' , $, ( #21, #22, #23, #24 );
#26= IFCRELDEFINESBYPROPERTIES( '32CCa7yhT2UA06gMRWfxbc' , #52, $, $, ( #20 ), #25 );
...

```

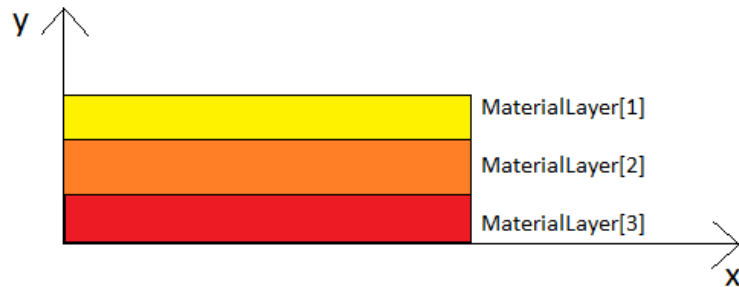
**Figure B.4 An example of code necessary to determine if a wall is external.**

### B.3.1.2 Determining orientation

The orientation of a wall is not directly needed for the external thermal envelope calculations, but the orientation of a window is. It is however simpler to ascertain the wall orientation than that of a window as the material layers of a wall can be used, whilst a window is composed of many polygons. As the window representation formally embeds into walls, a wall can be analysed in its place.

Objects such as walls are related to a material using the relationship *'IfcRelAssociatesMaterial'*. This entities attributes include the inherited attribute *'RelatedObjects'* and a direct attribute *'RelatingMaterial'*. The former describes a set of objects which are related to the latter. Objects such as walls can be described using layers of materials, and for the *'ExtractingIFCGeometry'* java file it is assumed that all *'IfcWallStandardCase'* entities are related to the entity *'IfcMaterialLayerSetUsage'*. This entities attributes are: *'ForLayerSet'*, *'DirectionSense'*, *'LayerSetDirection'* and *'OffsetFromReferenceLine'*. The *'ForLayerSet'* refers to an *'IfcMaterialLayerSet'* which contains the materials that build up the wall. For this project, based on observation of IFC files it is assumed that the convention for defining materials is from the external to the internal face. The *'LayerSetDirection'* denotes which direction the material layers should be built up. For a wall which has been extruded vertically, this direction is perpendicular to the direction of the extrusion, so the *'AXIS2'* (i.e. y-axis). The *'DirectionSense'*

denotes if individual material layers are assigned to the wall in the positive or negative y direction. Figure B.5 shows an example of a positive '*DirectionSense*'.

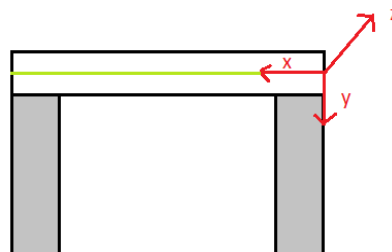


**Figure B.5 Describing material layers to a wall which has a positive '*DirectionSense*'.**

The '*OffsetFromReferenceLine*' is the offset of the material layers from a reference line. The offset is the distance between a reference line and the x-axis shown in Figure B.5. From observation of IFC files generated by Revit Architecture, and the IFC implementation Guide (Liebich 2009) the reference line is generally the wall path. Other observations include:

- the wall path is the centreline of the wall,
- the placement of the local axis of an '*IfcWall*' is at one end of a wall's centreline,
- the x-axis of the local placement coordinate system is always aligned with the wall centreline.

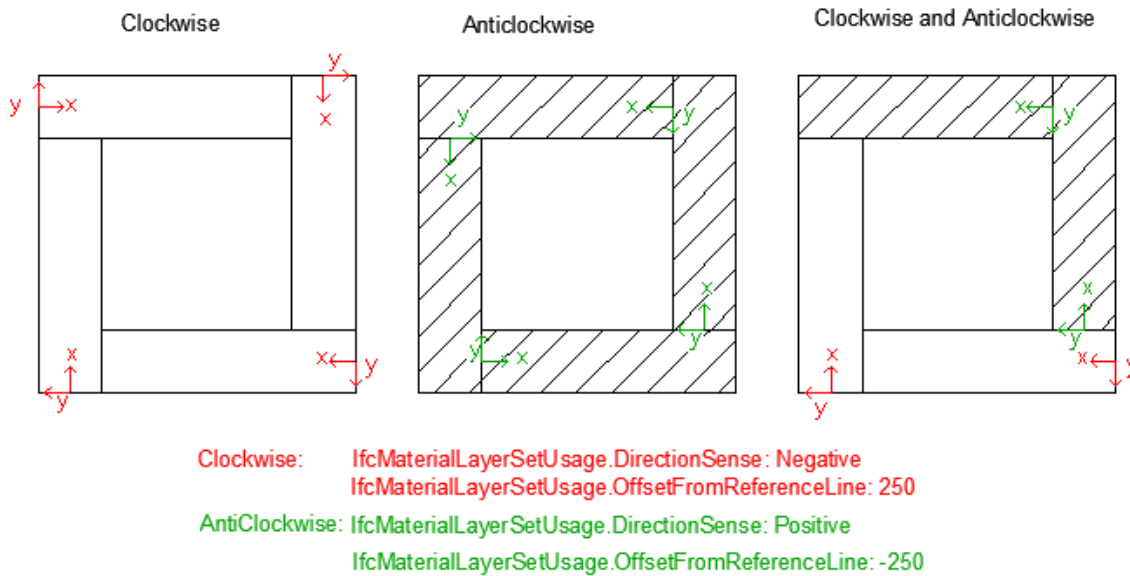
Figure B.6 shows an example to illustrate these observations. It shows three walls, and the location of the central walls local axis placement. Assuming the central wall has a thickness of 290mm, the '*IfcMaterialLayerSetUsage*' for this central wall would give it a positive '*DirectionSense*', an offset of -145mm and the '*LayerSetDirection*' would be '*AXIS2*'.



**Figure B.6 Local placement of wall coordinate system on a wall centreline.**

The attributes in '*IfcMaterialLayerSet*' are dependent on the direction a wall is placed in a BIM tool. Figure B.7 shows three buildings in plan view, each with the same four walls but drawn in different directions. The building on the left has all the

walls sketched in a clockwise direction, and the placement of each wall is to the left shown by a red axis. The building in the middle has all the walls drawn in an anticlockwise direction denoted as hatched, and the placement of the walls starts at the right end of the walls shown as a green axis. The building on the right has its top and right wall placed in an anticlockwise direction, and the bottom and left wall in a clockwise direction. The placements agree as described in the previous two examples. The *'DirectionSense'* and *'OffsetFromReferenceLine'* is shown at the bottom for both types of wall. The top two attributes are for the clockwise axis, and the bottom are for the anticlockwise.

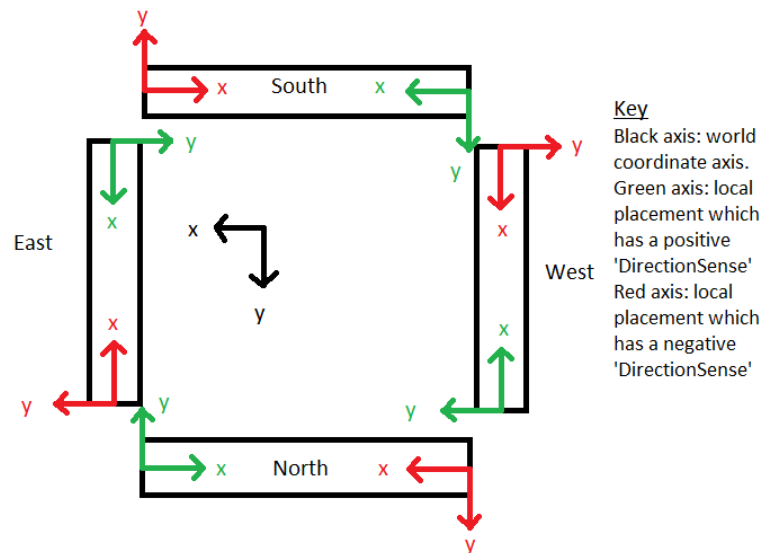


**Figure B.7 Buildings with walls drawn in clockwise and anticlockwise directions.**

It is important to note that these observations are used to draw figures in this section only, but they do not affect the way the *'ExtractingIFCGeometry'* works. In order to determine the orientation of an *'IfcWallStandardCase'*, solely its local placement and the *'DirectionSense'* in a related *'IfcMaterialLayerSet'* are needed.

Figure B.8 shows possible locations of coordinate systems for north, east, south and west facing walls in a plan view. For this example the WCS is shown to have an origin in the centre of the walls, but in IFC files this origin could be located anywhere. It depends on how the building is drawn, and where the WCS is placed by the user in the BIM model. The north direction of the project depends on the WCS and the entity *'IfcGeometricRepresentationContext'*. This entity has an optional direct attribute *'TrueNorth'*. If this direction is not given, it is assumed that North is in the positive y-axis of the WCS. One instance of the *'IfcGeometricRepresentationContext'* entity is mandatory for an IFC file.





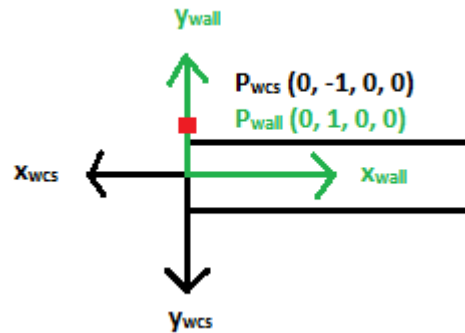
**Figure B.8 Plan view of walls and possible placements of local coordinate systems.**

The method for generating transformation matrices for objects developed in the last section can now be used to ascertain the orientation of a wall. A matrix which transforms points from the wall coordinate system from the WCS is used to transform a homogenous coordinate. The homogenous coordinate needs to be affected by rotations only, so the walls origin stays aligned to the WCS origin. This allows the following method to work for any wall, regardless to where the WCS is situated. For the homogenous coordinate to be unaffected by translations, its  $W$  coordinate has to remain as '0'. If the '*DirectionSense*' of the walls material is positive, the homogenous coordinate to be used is  $(0,1,0,0)$ . If it is negative, the homogenous coordinate is  $(0,-1,0,0)$ . The homogenous coordinate is now a unit vector whose direction is towards the internal face of the wall. Once it is converted from the wall coordinate system to the world coordinate system, it can be used to determine the orientation of the wall as the transformed coordinate will be a unit vector of the form:

- $(0,-1,0,0)$  which denotes the wall as facing North,
- $(-1,0,0,0)$  which denotes the wall as facing East,
- $(0,1,0,0)$  which denotes the wall as facing South,
- $(1,0,0,0)$  which denotes the wall as facing West.

Figure B.9 shows where the homogenous point is placed before and after a transformation, which is labelled as  $P_{wall}$  and  $P_{wcs}$  respectively. The wall is north facing, and has a positive '*DirectionSense*'. This method could be extended for

walls which are at an angle, by analysing if the transformed homogenous coordinate has positive or negative x and y values instead of positive or negative '1' value.



**Figure B.9** The transformation of a homogenous point from the wall to world coordinate system for a north facing wall with a positive '*DirectionSense*'.

### B.3.1.3 Extracting Wall Geometry

As mentioned in section B.1, each '*IfcProduct*' subtype will refer to an '*IfcShapeRepresentation*'. This has an attribute '*RepresentationType*' which for an '*IfcWallStandardCase*' will commonly be '*SweptSolid*' or '*Clipping*'. These two types of walls can be handled by the '*ExtractingIFCGeometry*' class. After wall dimensions have been determined, the external dimensions of the thermal envelope can be calculated. '*SweptSolid*' geometry involves extruding or rotating an area. As the case studies do not include a rotated '*SweptSolid*', an algorithm to process it was initially developed but work on it was abandoned as none of the test case studies implement this shape type. This is due to the roof always altering the top of the wall, so it will be represented as a clipped polygon. For completeness, section B.3.1.3.1 summarises how geometry information can be extracted from a '*SweptSolid*'. This is important as a '*Clipping*' shape is based on a '*SweptSolid*'. This is followed by a summary of how the '*Clipping*' shape representation is analysed and manipulated.

#### B.3.1.3.1 External dimensions of a '*SweptSolid*'

Figure B.10 shows part of an IFC file which describes a '*SweptSolid*'.

```
#89= IFCSHAPEREPRESENTATION(#44, 'Body', 'SweptSolid', (#80));
#80= IFCEXTRUDEDAREASOLID(#78, #79, #15, 8000.);
#78= IFCRECTANGLEPROFILEDEF(.AREA., $, #77, 10000., 290.);
#79= IFCAXIS2PLACEMENT3D(#3, $, $);
#15= IFCDIRECTION((0., 0., 1.));
#3= IFCCARTESIANPOINT((0., 0., 0.));
#77= IFCAXIS2PLACEMENT2D(#75, #21);
#75= IFCCARTESIANPOINT((5000., 0.));
#21= IFCDIRECTION((-1., 0.));
```

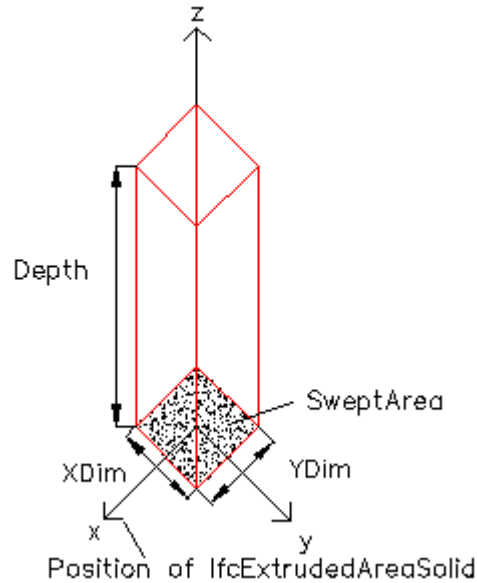
**Figure B.10** '*SweptSolid*' description in an IFC file.

For a *'SweptSolid'* (Liebich 2009):

- The last attribute of *'IfcShapeRepresentation'* is called *'Items'* and it can refer to one *'IfcRepresentationItem'* subtype entity.
- This item is an *'IfcExtrudedAreaSolid'* entity, which will be extruded vertically.

*'IfcExtrudedAreaSolid'* has the attributes *'SweptArea'*, *'Position'*, *'ExtrudedDirection'* and *'Depth'*. The *'Depth'* is the extrusion depth of the wall height, and the *'SweptArea'* refers to the area that is being extruded. The *'SweptArea'* is commonly filled by an *'IfcRectangleProfileDef'* entity, which has the attributes *'XDim'* and *'YDim'*. The *'XDim'* describes the walls length and the *'YDim'* describes its width. All these attributes are shown in Figure B.11. As mentioned above, the *'ExtrudedDirection'* for a wall has to be the z-axis.

The external area of a *'SweptSolid'* wall is calculated by multiplying the value of the *'Depth'* and *'XDim'*. This area is not the final exterior area of a wall. As Figure B.7 shows, where two walls join (a) the side face of one wall may be part of the external face of another wall, or (b) the end face of a wall may simply join the internal face of the other wall. How walls connect to other walls is described by *'IfcRelConnectsPathElements'*, and more information on this entity can be found in the next section, B.3.1.3.2. If this wall is connected to other walls, and is a *'RelatedElement'* such as in Figure B.12, the side area of the *'RelatingElement'* walls has to be added to this area before it gives a true representation of the external surface area at that elevation. If the connected *'RelatingElement'* is a *'SweptSolid'*, then the walls *'Depth'* and *'YDim'* are used to calculate this missing area.



**Figure B.11** The attributes of an *'IfcExtrudedAreaSolid'* and *'IfcRectangleProfileDepth'*.

#### B.3.1.3.2 External dimensions of a 'Clipping'

If the *'IfcWallStandardCase'* is described as a *'Clipping'* by the *'IfcShapeRepresentation'*, the geometry is “given as a Boolean difference of the extruded solid and one or more half space solids (*'IfcHalfSpaceSolid'* or subtypes)” (Liebich 2009). As with the *'SweptSolid'*, the restriction on *'IfcShapeRepresentation'* is that its *'Items'* attribute will in fact only point towards a single item.

One way of interpreting the data given is as follows: the geometrical shape is determined by initially clipping an *'IfcExtrudedAreaSolid'* with a surface, and then clipping the resulting shape with other surfaces. The restriction to this surface is that it has to be a plane. The entity which holds the information on which plane should be used next and what shape it will alter is the *'IfcBooleanClippingResult'*. This entity has the attributes *'Operator'*, *'FirstOperand'* and *'SecondOperand'*. The *'FirstOperand'* holds an *'IfcExtrudedAreaSolid'* for the first modification. For later adjustments it contains an *'IfcBooleanClippingResult'*. For bounded planes used for straight walls, the *'SecondOperand'* direct attention to an *'IfcPolygonalBoundedHalfSpace'*. This has the attributes *'BaseSurface'* and *'AgreementFlag'*, and also designates the shape which is to be cut by the *'BaseSurface'* using the attribute *'PolygonalBoundary'*. The *'BaseSurface'* alludes to an *'IfcPlane'*. The *'BaseSurface'* has one attribute, which refers to an *'IfcAxisToPlacement3D'*. The *'AgreementFlag'* is Boolean, and stipulates if the shape described by *'IfcPolygonalBoundedHalfSpace'* below or above the *'BaseSurface'* should be subtracted. If the *'AgreementFlag'* is equal to *'false'*, everything below the x-y axis of the plane is subtracted. If it is *'true'*, everything

above the x-y axis of the plane is subtracted. The remaining shape representation is taken away from the shape described by the *'FirstOperand'* if the attribute *'Operator'* of the *'IfcBooleanClippingResult'* entity contains the value *'Difference'*.

The process in this project to determine the coordinates of the vertices of a wall area is as follows:

- The *'IfcBooleanClippingResult'* that is referred to by the *'IfcShapeRepresentation'* is examined.
- Information is extracted about the *'IfcAxis2Placement3D'* of the *'BaseSurface'* from the *'SecondOperand'*.
- If *'FirstOperand'* is also an *'IfcBooleanClippingResult'* itself, repeat Step 2 for this new *'IfcBooleanClippingResult'*. Keep repeating until the new *'FirstOperand'* equals an *'IfcExtrudedAreaSolid'*.
- Extract information about the walls from the attributes *'Depth'*, *'XDim'* and *'OffsetToReferenceLine'* (see section B.3.1.3.1).

Now that the height, length and offset from the reference line have been determined, the vertices of the external face of a wall can be calculated. This is based on the assumption made earlier, that the *'IfcMaterialLayerSet'* defines materials from the external to the internal face. In order to work out an area, the vertices of the unclipped wall must be established. These will represent a polygon, which can be clipped using the information from *'BaseSurface'* and *'AgreementFlag'*.

The vertices of the wall are calculated in the wall coordinate system and in the homogenous form so they can be manipulated between the wall and clipping plane coordinate systems. The vertices are in an anticlockwise direction, start from origin of the walls local placement but are located *'OffsetToReferenceLine'* away in order to be at the external face:

- (0, OffsetToReferenceLine, 0, 1)
- (0, OffsetToReferenceLine, Depth, 1)
- (XDim, OffsetToReferenceLine, Depth, 1)
- (XDim, OffsetToReferenceLine, 0, 1).

Before these vertices can be used to represent an external face which is ready for clipping, they may have to be adjusted to take into account the sides of connecting walls. The connections of walls are described by the *'IfcRelConnectsPathElements'* entity, which is described in more detail in the section B.3.2 *'Extracting the area of a floor are: IfcSlab'*. Similarly to the *'SweptSolid'* type wall, all the *'RelatedElement'* attributes of the *'IfcRelConnectsPathElements'* relationship are checked to see if they allude to the wall in the process of being clipped. If one is found it means the wall in questions external face needs to have the side face of a RELATING wall added to it. When a *'RelatedElement'* is found, the *'RelatingElement'* is checked to see if it is an external or internal wall. If it is external, this second walls height *'Depth'* and width *'YDim'* are extracted. The location of these attributes will depend on if the wall is a *'SweptSolid'* or *'Clipping'*. If the *'RelatedConnectionType'* attribute of *'IfcRelConnectsPathElements'* content is equal to *'AtStart'*, the connection is located at the start of the wall path. This usually coincides with the walls local placement origin. This means that the initial two vertices have to have the width of the *'RelatingElement'* wall taken away from their x coordinates. If it is equal to *'AtEnd'*, the connection is at the end of the wall path, which means that the last two coordinates have to have the width of the wall added to their x coordinates. Figure B.12 shows a wall *'W3'* which is a *'RelatedElement'* at both the start and end of its wall path. The initial points *'P1'* and *'P4'* can be seen on the exterior face of the wall, as well as the adjusted points which take into account the connecting walls. Points *'P2'* and *'P3'* would be located above points *'P1'* and *'P4'*, but they would be located at a height of the unclipped wall.

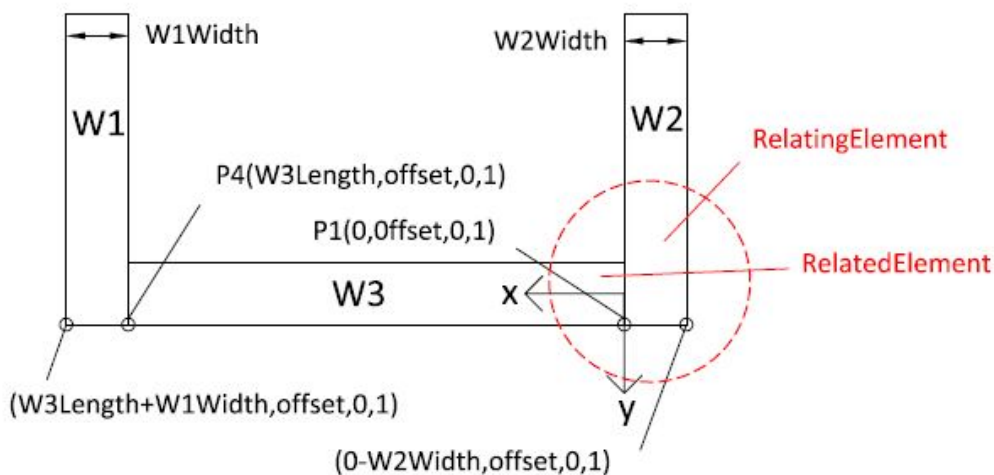
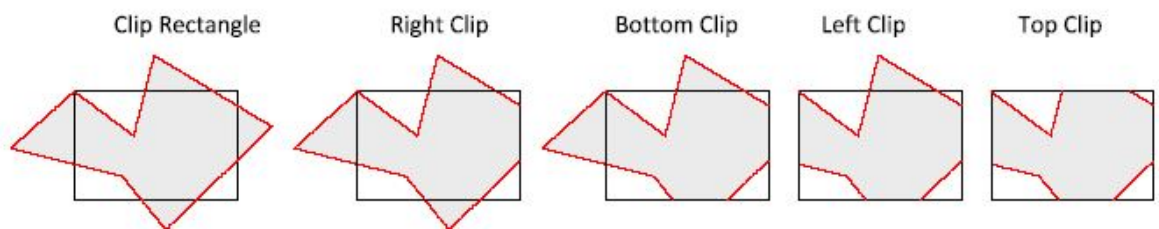


Figure B.12 Walls showing adjusted coordinates for the exterior face of a wall.

The polygon representing the wall is now ready to be clipped by planes. The *'ExtractingIFCGeometry'* class extends the Sutherland-Hodgman polygon clipping algorithm described by (Foley et al. 1996). The original algorithm alters the shape of a 2D polygon using the four sides of a rectangle, in the steps shown in Figure B.13. The polygon is in the form of a list of vertices, and the edge of the rectangle which is cutting the shape of the polygon is a 2D line. The list of vertices is adjusted four times, once for each side of the rectangle. Vertices *'outside'* of the rectangle are discarded, and new vertices are found based on the intersection of the lines created by the edge of the rectangle and vertices which define the sides of the polygon.



**Figure B.13** The original Sutherland-Hodgman clipping algorithm steps.

In the *'ExtractingIFCGeometry'* class, the structure of the algorithm is similar to the original, but the functions are created so the polygon is a) described in 3D space, b) the cutting is performed by a plane instead of a 2D line and c) the polygon is clipped by many planes, as opposed to the four sides of a rectangle shown in Figure B.13. An outline of the algorithm used by the *'ExtractingIFCGeometry'* class to modify polygons with planes is shown in Figure B.14. This process is repeated for every plane related to an *'IfcBooleanClippingResult'*. The *'InVertexArray'* is initially equal to the vertices of the exterior wall face in the wall coordinate system, as established earlier. After the process in Figure B.14 has finished, the *'InVertexArray'* is filled with the vertices stored in the *'OutVertexArray'*, in preparation of another clipping.

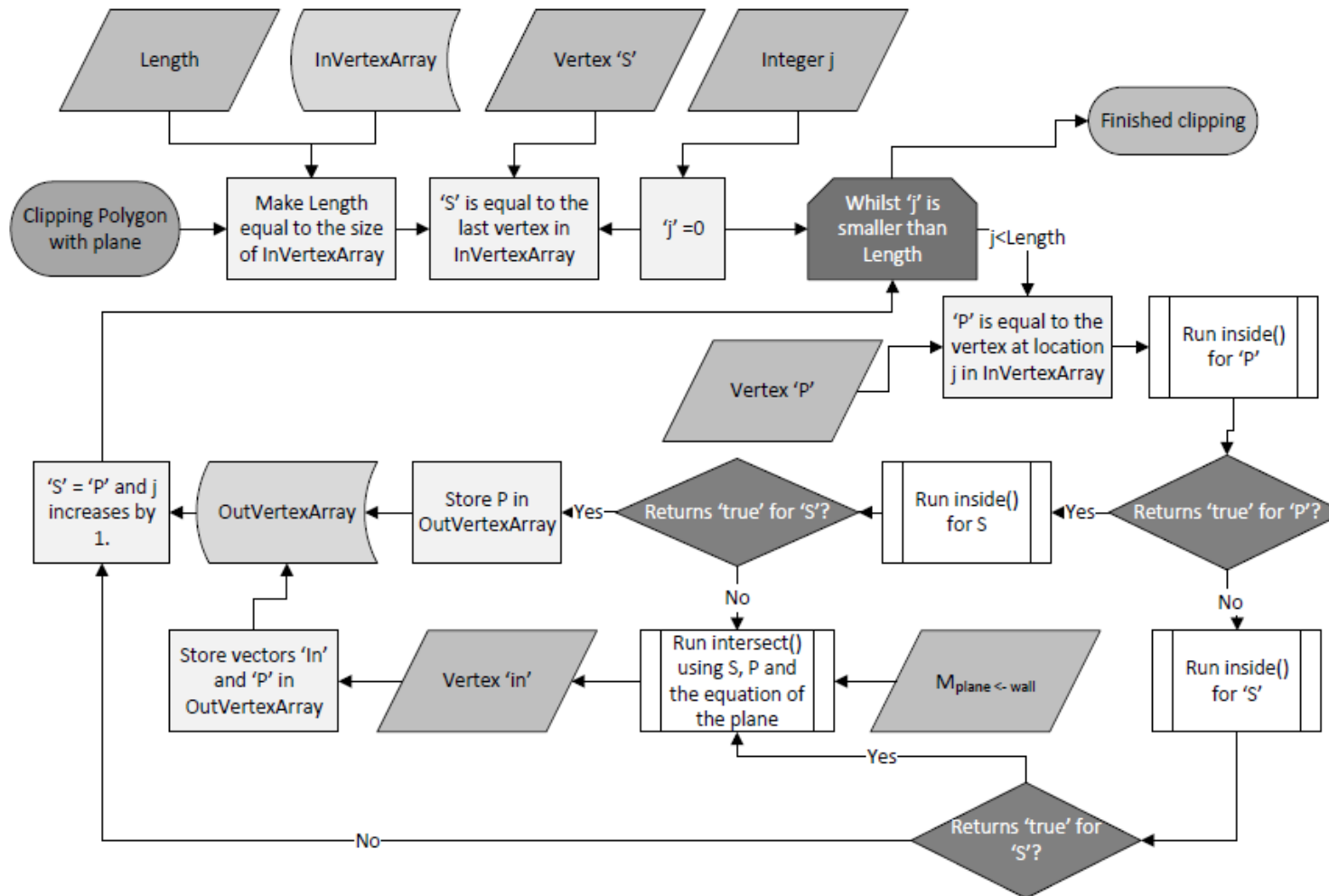
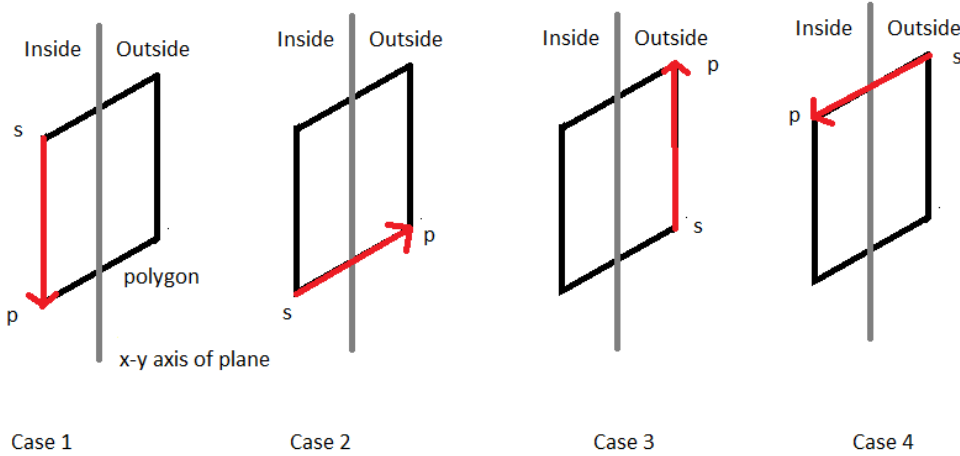


Figure B.14 The extended Sutherland-Hodgman clipping algorithm.



The algorithm starts with the last and first vectors, and tests which side of the plane the vertices are located. This is done by the function *'inside()'*. This function first transforms vertices from the wall coordinate system to the plane coordinate system. The matrix which performs these transformations is calculated based on the *'IfcAxis2Placement3D'* entity related to the plane. The process of composing a transformation matrix is detailed in section B.2. It must be kept in mind however that the plane coordinate system is placed relatively to the wall coordinate system. In the example in section B.2 *'Transforming points and coordinate systems'*, a matrix is composed for transforming *from* a coordinate system *'A'* to one that *'A'* is placed relative to. The element to plane coordinate system transformation is in the opposite direction, as the transformation is *to* a coordinate system *'B'* *from* one that *'B'* is placed relative to. The matrix for this type of transformation can be created in two ways from IFC data. In the last section a matrix transforming *from* a coordinate system *'A'* to one that *'A'* is placed relative to was created by multiplying matrices in Equation B.19 and Equation B.20. The opposite transformation can be described by inverting the final transformation matrix. An alternative way is to not invert the rotation matrix as is done in Equation B.20, but instead invert the translation matrix which is in Equation B.19.

When vertices are transformed to the plane coordinate system, the *'inside()'* function tests if they are *'inside'* or *'outside'*. A vertex is labelled as inside if the *'z'* coordinate is negative and *'AgreementFlag'* of the *'IfcPlane'* is *'false'*, or if the *'z'* coordinate is positive and *'AgreementFlag'* is *'true'*. A vertex is otherwise regarded as *'outside'*. Pairs of vertices are examined at the same time, in order to calculate if the side of a polygon is (a) inside the plane, (b) outside the plane or (c) if it needs to be modified. The vertices of the polygon after it is cut by a plane are stored in *'OutVertexArray'*. Figure B.15 shows the four different cases that the algorithm processes. In Case 1, both the vertices are inside, and the resulting action is *'P'* would be stored in *'OutVertexArray'*. In Case 2, *'S'* is inside and *'P'* is outside. Consequently neither *'S'* nor *'P'* is output to *'OutVertexArray'*, but instead the intersection of the plane and line *'SP'* would be output. In Case 3, both vertices are outside the plane and nothing is output at all. In Case 4, *'S'* is outside and *'P'* is inside. In this case, a vertex describing the intersection would be output to *'OutVertexArray'* and its value would overwrite vertex *'P'*. This process of deciding which vertex to output is described also in the data flow diagram in Figure B.14. This diagram shows that the intersection is calculated by a separate function called *'intersection()'*.



**Figure B.15** Different cases of polygon edges being clipped by a plane.

The *'intersection()'* function is based on the method of calculating the intersection of a line and plane in which can be found in Schneider and Eberly (2003). The equation for a line is based on the vertices 'S' and 'P', and the equation of a plane is based on data from its *'IfcAxis2Placement3D'* entity. A linear component *'L(t)'* such as a line segment can be defined using its point of origin *P* and direction  $\vec{d}$  as:

$$L(t) = P + t\vec{d} \quad \text{which can be equal to a point Q.} \quad \text{(Equation B.21)}$$

The Vertex *S* is used directly for *P*, and  $\vec{d}$  is equal to  $\overrightarrow{SP}$ . The unit normal of the cutting plane can be described in the form of  $\hat{n} = [a \ b \ c]$ . If the distance from the plane to the origin is called '*d*', the equation of a plane '*ρ*' can be defined as:

$$ax + by + cz + d = 0 \quad \text{(Equation B.22)}$$

An *'IfcPlane'* has one attribute called '*Position*', which can be filled by an *'IfcAxis2Placement3D'*. The unit normal of a plane in the WCS can be found in the '*Axis*' attribute of this *'IfcAxis2Placement3D'* entity. The distance of a plane to the origin can be worked out using the dot product of a point '*X*' on a plane '*ρ*' and its unit normal  $\hat{n}$  (Olive 2003). The *'intersection()'* function uses the local placement of the plane for the '*X*' value. This is defined by the '*Location*' attribute of the aforementioned *'IfcAxis2Placement3D'* entity. The intersection point '*Q*' of a plane and a line has to satisfy Equation B.21, so an intersection can be worked out by substituting Equation B.21 into Equation B.22 to form:

$$a(P_x + d_x t) + b(P_y + d_y t) + c(P_z + d_z t) + d = 0 \quad \text{(Equation B.23)}$$

This can be rearranged so it can be solved for parameter '*t*':

$$t = \frac{-(\hat{n} \cdot P + d)}{\hat{n} \cdot \vec{d}}. \quad \text{(Equation B.24)}$$

The parameter ‘t’ can now be substituted back into Equation B.21 to find the intersection point ‘Q’.

Once the extended Sutherland-Hodgman algorithm in Figure B.14 has been followed for all the clipping planes given in an IFC file, the ‘OutVertexArray’ will contain the vertices of the final clipped external wall face. This is the extents of the face which would be seen if the wall was viewed in an IFC visualization tool. The wall still needs to be adjusted to contain the side area of the lowest floor it touches. If the highest floor is the top thermal boundary of the building, then the wall also needs to be cropped or extended to this height.

#### B.3.1.3.3 *Adjustments for thermal boundary dimensions*

In the IFC schema, floors, stair landings and roofs are represented with the entity ‘IfcSlab’ (Liebich 2009). The entities ‘IfcSlab’ and ‘IfcWallStandardCase’ are both related to many spaces described each by an ‘IfcSpace’ through the relationship ‘IfcRelSpaceBoundary’. A list of all the ‘IfcSlab’ entities which are connected to the same spaces as a wall can be used to determine which walls are connected to which floors and roofs. Walls can then be adjusted to include floor and roof depths if it is necessary. Adjusting vertices of walls held in the outVertexArray is done by: identifying the floors and walls related to a wall, calculating the highest and lowest floor face, adjusting any wall vertices with a z coordinate equal to zero to the value of the lowest floor face, identifying the location of the thermal boundary, adjusting any wall vertices of walls with thermal boundaries in the roof which have the z coordinate above zero to include the depth of the roof, and adjusting any wall vertices of walls with thermal boundaries in the top floor so only the wall area below the highest floor face is counted towards the PHPP wall area. These steps are described below in more detail.

First, the wall areas are adjusted to include the floor located underneath it. The ‘IfcModel’ is iterated through to find all the ‘IfcSlab’ entities which have a ‘PredefinedType’ of ‘FLOOR’ and located next to the wall is question. As the standard body representation type of an ‘IfcSlab’ is a ‘SweptSolid’ (Liebich 2009), this is the type of slab processed by ‘ExtractingIFCGeometry’. This representation type of ‘IfcSlab’ will have its geometry described by an ‘IfcExtrudedAreaSolid’, and will be extruded in a direction perpendicular to the x-y plane of its ‘IfcExtrudedAreaSolid.Position’. There is no convention stating if a floor should be

extruded highest to lowest face or vice versa. The highest and lowest faces of a floor are therefore both considered when deciding which face gives an ultimately highest and lowest height. The process of calculating the heights starts by creating transformation matrices for each '*IfcSlab*' which relate to the floor extrusion start and finish, and multiplying them with the homogenous point (0,0,0,1). The x coordinates of the transformed points will give the highest or lowest heights of floors related to the wall being examined, in the WCS.

The initial transformation matrix will be used to generate the distance from the WCS origin to the beginning of the extrusion. It transforms points from the '*IfcExtrudedAreaSolid*' coordinate system to the WCS. This matrix is created by composing the matrices for the following transformations:

$$M_{WCS \leftarrow IfcExtrudedAreaSolid} \quad \text{(Equation B.25)}$$

$$= M_{WCS \leftarrow IfcSlab} * M_{IfcSlab \leftarrow IfcExtrudedAreaSolid}$$

The matrix  $M_{WCS \leftarrow IfcSlab}$  is created using the method in section B.2 'Transforming points and coordinate systems'. The matrix  $M_{IfcSlab \leftarrow IfcExtrudedAreaSolid}$  is created using the same method but with a slight adjustment. Instead of using several '*IfcLocalPlacement*' entities which are related to '*IfcAxisToPlacement3D*' entities, it is created using just the '*Position*' attribute of '*IfcExtrudedAreaSolid*'. This is already an '*IfcAxis2Placement3D*' entity with data on translations and rotations, and no relative placements are necessary to consider. The resulting transformation matrix is saved in a separate list, called '*slabHeights*'.

The second transformation matrix will be used to generate the distance from the WCS origin to the end of the extrusion. This starts with the matrix  $M_{WCS \leftarrow IfcExtrudedAreaSolid}$  and then multiplies it by a translation matrix which moves the coordinate system in the extrusion direction by the extrusion depth. The extrusion depth is stored in '*IfcExtrudedAreaSolid.Depth*', and the direction is a vector stored in '*IfcExtrudedAreaSolid.ExtrusionDirection*'. The depth is used as a scalar, and multiplies the direction vector to give a vector in the form of (dx, dy, dz). The coordinates dx, dy and dz are then used to generate a translation matrix  $T_{ExtrusionEnd}$  in the form of Equation B.19. The composed matrix  $M_{WCS \leftarrow IfcExtrudedAreaSolid} * T_{ExtrusionEnd}$  is also stored in the list '*slabHeights*'.

Once all the slabs related to the wall have been processed, the matrices in '*slabHeights*' are ready to be multiplied by with the homogenous point (0,0,0,1). The highest and lowest 'z' coordinates of the resulting points in '*slabHeights*' can now be

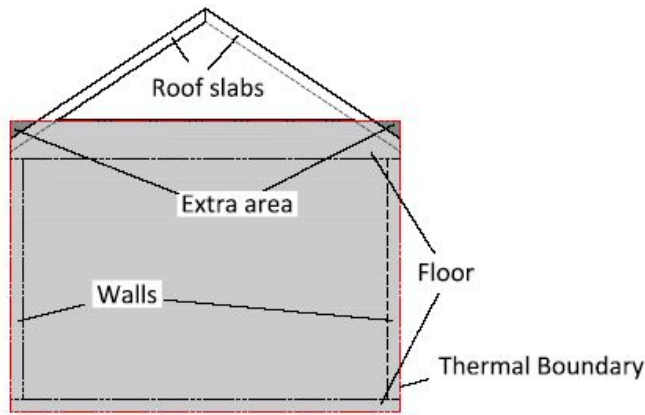
used to update walls where the thermal boundary is in the roof. As the points in *'slabHeights'* are currently in the WCS, and the wall vertices in *'OutVertexArray'* mentioned previously are in the wall coordinate system, the vertices in *'OutVertexArray'* have to be transformed from the wall coordinate system to the WCS. This is done by multiplying the transformation matrix  $M_{WCS \leftarrow IfcWallStandardCase}$  (which can be derived using the section B.2 Transforming points and coordinate systems) by each vertex held in *'OutVertexArray'* to give a vertex in the wall coordinate system.

For the addition of a slab depth to a wall, the transformed vertices in *'OutVertexArray'* which have a 'z' coordinate equal to '0', are overwritten to hold the lowest floor 'z' coordinate. The polygon has now been either extended to the lowest face of the floor, or left as it is. The main assumption in this process is that the vertices defining a walls floor start at the WCS  $z=0$  plane, a process which is described by Wing (2009). This process would have to be extended in order to work for walls on a sloped surface.

The next step checks if the roof or the floor it sits on is the thermal boundary. This changes how much of the wall area is counted towards the *'exterior wall area'* in PHPP. The relationship *'IfcRelSpaceBoundary'* relates spaces and elements, so it can be used to determine if spaces related to walls are also related to roofs. If this relation is found, it is assumed that the thermal boundary is in the roof.

If the thermal boundary is in the roof, *outVertexArray* must be updated by adding the depth of the roof to the wall vertices that are above ground level. This is done by identifying which roofs are related to the wall in question, then extracting the roof thickness from the *'IfcSlab'* which describes the roof geometry. At this point the *'SweptSolid'* representation type of roofs is the only type supported. The vertices which have a 'z' coordinate above zero can be increased with the roof depth.

If the thermal boundary is in the top floor, any 'z' coordinate of vertex of the wall which is above zero is changed to the 'z' coordinate of the highest floor face which it is related to. This disregards any part of a wall which is outside of the thermal boundary, and assumes that walls do not finish below the thermal boundary. This assumption is fair to make as in most cases if a wall finished before a thermal boundary it would seem there was a hole in the building. Another issue is the top of the insulation may be cut into by the roof as is shown in Figure B.16. This shows the resulting thermal envelope is complete, but it is not quite exact.



**Figure B.16** The external wall face and error added by extending walls.

The final area of the polygon described by ‘*OutVertexArray*’ can be calculated using the following equation based on Green’s Theorem, adapted from (Davis and Raianu 2007):

$$\text{Polygon Area} = \frac{1}{2} * \sum_{i=1}^{n-1} (b_i + b_{i+1}) * (a_{i+1} - a_i) \quad \text{(Equation B.26)}$$

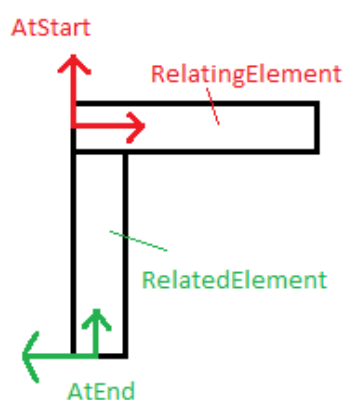
For walls oriented to the south and north, ‘*a*’ is set to the *x* coordinate of ‘*OutVertexArray*’, and ‘*b*’ is set to the ‘*z*’ coordinate. For east and west oriented walls, ‘*a*’ is set to the ‘*y*’ coordinate of ‘*OutVertexArray*’, and ‘*b*’ is set to the ‘*z*’ coordinate.

Once a wall area is calculated, it is saved depending on the wall type. The entity ‘*IfcWallStandardCase*’ has an attribute ‘*ObjectType*’, which is where a walls name from AutoDesk Revit is saved. A list is created by PassivBIM of each new wall type encountered, and the wall area is updated when each new wall instance is analysed. Before the wall area is added to the area in the list, any related windows and door areas are taken away from it. The windows and doors are related to the wall through the ‘*IfcRelVoidsElement*’ relationship. The geometry of the windows and walls are calculated using the methods described in sections B.3.4 ‘External door area: *IfcDoor*’ and B.3.6 ‘Extracting the Treated floor area: *IfcSpace* and *IfcWindow*’. The area can now be used for PHPP transmission heat loss calculations.

### B.3.2 EXTRACTING THE FLOOR AREA: *IfcSLAB*

In AutoCAD Revit Architecture, when a floor is being drawn it can be snapped to either the external or internal face of walls. PHPP calculations use only dimensions of the floor to the exterior edge of the wall (section 5.2.2). In order to avoid the area being too small due to the wall base area not being counted, the floor slab vertices

are assigned a selection of floor vertices. Only certain vertices from certain walls from an IFC file are suitable, as some walls are represented shorter than the exterior facade width in order to avoid overlapping. The detail of how walls meet is described by the *'IfcRelConnectsPathElements'* entity. This has the attributes *'RelatingElement'*, *'RelatedElement'*, *'RelatedConnectionType'* and *'RelatingConnectionType'*. The first two describe elements such as walls, and the last two describe if it is the start or end of the wall path. *'RelatedConnectionType'* and *'RelatingConnectionType'* can be filled by an *'IfcConnectionTypeEnum'*, which can be either *'AtStart'*, *'AtEnd'* or *'AtPath'*. The start of a wall path is generally at the local placement of a wall, based on examples in Liebich (2009) and Liebich et al. (2007). An example of an L-shaped connection between two walls is given in Figure B.17. This shows walls where the *'RelatingElement'* has the *'RelatingConnectionType'* of *'AtStart'* and the *'RelatedElement'* has the *'RelatedConnectionType'* of *'AtEnd'*.



**Figure B.17 An L-shaped connection of two walls.**

In order to establish all the vertices at ground level of a building, all the *'IfcRelConnectsPathElements'* which describe two external walls must be found. The *'RelatedElement'* and *'RelatingElement'* is noted from the first *'IfcRelConnectsPathElements'*. Then the transformation matrix from the wall to the WCS of the *'RelatingElement'* is calculated, and its length and offset from the reference line is extracted as described in the previous section. The offset is assumed to be the distance from the wall body path to the external face of a wall. This is based on:

- the offset description in the IFC 2x3 TC1 Schema description: “*Offset of the material layer set base line (MlsBase) from reference geometry*” (buildingSMART 2013),

- and the material layers have been assumed to be given from the exterior to interior face in this project.

In order to calculate the coordinates of a vertex, the distance from the origin of the wall placement to the vertex has to be determined in both the x- and y-axis direction. The initial value of the vertex is assumed as (0, 0, 0, 1), the origin of the wall placement. Each connection has the attribute '*RelatingConnectionType*'. For an '*AtStart*' relating wall, the offset value has to be added to the y coordinate: (0, offset, 0, 1). For the vertex of an '*AtEnd*' relating wall the offset is added to the y vertex coordinate, and the length of the wall is added to the x vertex coordinate: (length, offset, 0, 1). The resulting vertex coordinates are then multiplied by the relevant wall transformation matrices to become a point in the WCS.

Once this point is found, all the remaining '*IfcRelConnectsPathElements*' must be examined to extract another vertex. The area of the floor can then be worked out as a 2D polygon, but the vertices must be in the right order. To guarantee this, when an '*IfcRelConnectsPathElements*' is analysed, the '*RelatingElement*' wall step line number is remembered. It is used to find another '*IfcRelConnectsPathElements*' which has a '*RelatingElement*' or '*RelatedElement*' which has a wall with the same step line number. This will be the right vertex as it is at the other end of one of the same wall. In this '*IfcRelConnectsPathElements*', a new wall will be referred to and the next '*IfcRelConnectsPathElements*' should be one which has a '*RelatingElement*' or '*RelatedElement*' with the step line number of this new wall. This process should be repeated until there are no more '*IfcRelConnectsPathElements*'.

The resulting x and y coordinates of the vertices form a planar 2D polygon, whose area can be calculated using Equation B.26, and setting  $a = x$  and  $b = y$ .

### B.3.3 EXTERNAL WINDOW AREA: *IfcWindow*

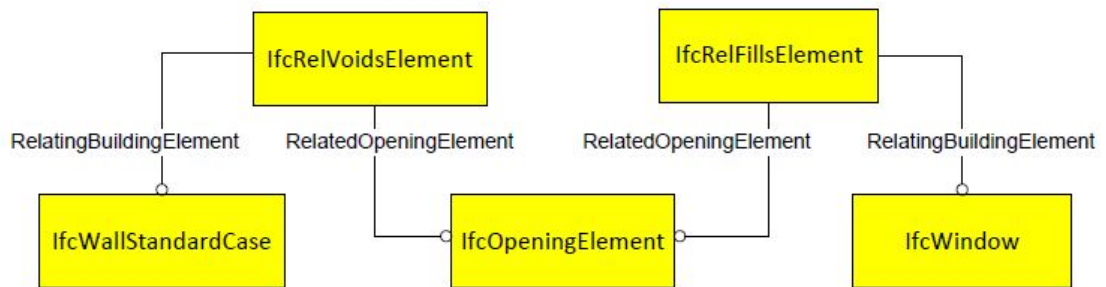
In PHPP, the orientation of a window is important as the windows area is used in heat gain calculations. Therefore, an '*IfcWindow*' must first be classified by orientation, and then its area can be calculated and stored according to this. The total window area for a specific orientation is used later by the heat demand calculation to calculate solar heat gain.

#### B.3.3.1 Orientation

A windows orientation is the same as the orientation of the wall it is located in. The process of determining the orientation of a wall has already been explained in



section B.3.1.2 “*Determining orientation*”. In the IFC schema, windows are joined to an opening by the ‘*IfcRelFillsElement*’ which has the attributes ‘*RelatedOpeningElement*’ and ‘*RelatedBuildingElement*’. The ‘*RelatedBuildingElement*’ refers to ‘*IfcElement*’ subtypes, which in the case of a window is the ‘*IfcWindow*’ entity. The ‘*RelatedOpeningElement*’ refers to the ‘*IfcOpeningElement*’ and its subtypes. The ‘*IfcOpeningElement*’ is connected to an ‘*IfcElement*’ through the relationship ‘*IfcRelVoidsElement*’. The insertion of a window into a wall is shown in Figure B.18.



**Figure B.18** Inserting an ‘*IfcWindow*’ into an ‘*IfcWallStandardCase*’.

### B.3.3.2 Dimensions

Now that the orientation of a window has been defined, its area can be calculated by multiplying together the following direct attributes of ‘*IfcWindow*’: ‘*OverallHeight*’ and ‘*OverallWidth*’.

#### B.3.4 EXTERNAL DOOR AREA: *IFCDOOR*

Before the area of a door is calculated, it has to be determined if the door is external or internal. This can be done with the same method that is in section B.3.1.1 “*Is it External?*” for a wall. The only exception is the attribute ‘*name*’ of the ‘*IfcPropertySet*’ is equal to ‘*Pset\_DoorCommon*’ instead of ‘*Pset\_WallCommon*’.

The ‘*IfcDoor*’ entity has two direct attributes ‘*OverallHeight*’ and ‘*OverallWidth*’, which are multiplied together to get the external door area necessary for PHPP. This area also needs to be extracted from the total external wall area.

#### B.3.5 EXTERNAL ROOF AREA: *IFCSLAB* AND *IFCROOF*

In a BIM tool such as Revit, a roof is represented as an extruded polygon shape (Wing 2009). In an IFC file, information about a roof is held in ‘*IfcRoof*’ entities. Information on roof dimensions could also be taken from property sets. These tend to include the areas of overhangs, which are outside of the thermal envelope and therefore not suitable for the total roof area for PHPP. An ‘*IfcRoof*’ entity is an aggregation of ‘*IfcSlab*’ entities, so geometrical information about a roof must be

gained from the *'IfcSlab'* entity. This entity is also used to represent floors and stair landings. The slabs which describe a roof are related to it through the *'IfcRelAggregates'* entity with the roof as a *'RelatingObject'* and the slabs as *'RelatedObjects'*.

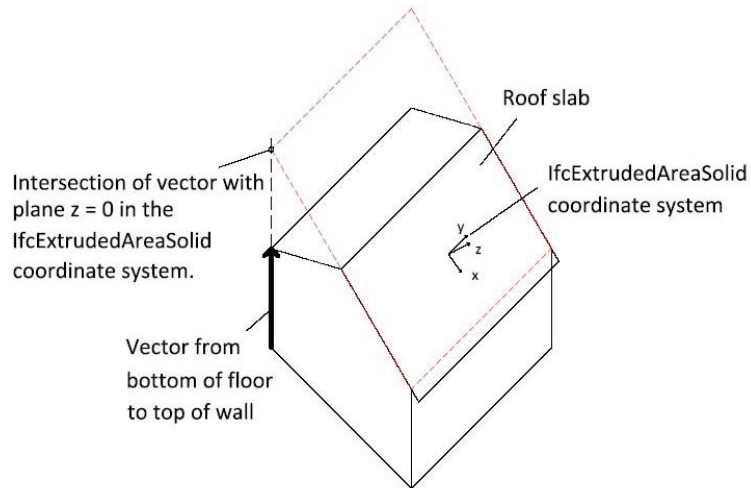
*'IfcSlab'* entities have *'Placement'* and *'Representation'* attributes, and the area of a roof can be calculated from the *'Representation'* entity. An *'IfcSlab'* can have the *'Representation'* of an *'IfcExtrudedAreaSolid'* for standard slabs or an *'IfcBooleanClippingResult'* for slabs with cut edges (Liebich 2009). *'ExtractIfcGeometry'* currently only deals with an *'IfcExtrudedAreaSolid'* representation, but it could be easily extended for an *'IfcBooleanClippingResult'* representation based on the methodology used for a wall.

For the PHPP calculation, the area of the roof needed is based on the location of the thermal envelope. If the thermal envelope is the actual roof of the building, then the slabs that represent the roof in an IFC file are used to calculate the PHPP roof area. They have to be adjusted not to include any overhangs. If the thermal envelope is in the highest floor, then the PHPP roof area is taken as the area projected by the roof without overhangs onto a horizontal plane in the WCS.

An overhang can be removed by cutting the lower (internal) faces of slabs with a projected outline of the bottom floor using the Sutherland-Hodgman clipping algorithm. This can be seen in Figure B.19. This works with the assumption that any part of a buildings envelope extruding past the top of external walls will be an overhang. The current method would not work for non vertical walls, but it could be extended to use the vertices of top floors instead in order to overcome this.

Each roof slab is analysed separately. The first step is to project the lowest floor slab onto the  $z=0$  plane in the *'IfcExtrudedAreaSolid'* coordinate system. This coordinate system is described by the attribute *'Placement'* of the *'IfcExtrudedAreaSolid'* entity. The slab is projected by intersecting the  $z=0$  plane and vectors created from floor vertices (labelled "*Vector from bottom of floor to top of wall*" in Figure B.19). The vectors are created from (a) the vertices from the floor slab calculation and (b) the same vertices but with the wall height in the  $z$  coordinate. All vertices are in the WCS. The vectors must now be intersected with the  $z=0$  plane in the *'IfcExtrudedAreaSolid'* coordinate system. The intersection is performed using the *'intersect()'* function from the extended Sutherland-Hodgman algorithm described in section B.3.1.3.2 "*External dimensions of a 'Clipping'*". The input for this function will be twofold: (a) the vectors pointing from the floor vertices in a

horizontal direction, and (b) the transformation matrix  $M_{IfcExtrudedAreaSolid \leftarrow WCS}$ . The matrix can be generated using the method developed in section B.2 ‘Transforming points and coordinate systems’. The transformation matrix is necessary as the normal of the plane and its local placement can be extracted from it. These are then used by the ‘*intersect()*’ function.

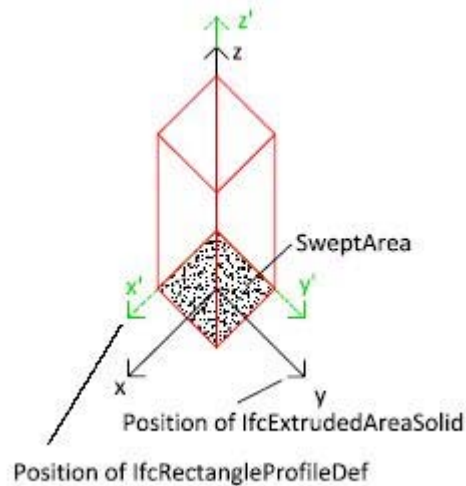


**Figure B.19 Bottom floor being projected onto the  $z=0$  plane of the ‘*IfcExtrudedAreaSolid*’ coordinate system.**

Once calculated, the intersection will be in the WCS. It needs to be converted to the ‘*IfcExtrudedAreaSolid*’ coordinate system, which can also be performed using the matrix  $M_{IfcExtrudedAreaSolid \leftarrow WCS}$ .

The second stage is to determine the vertices of the roof slab. The outline of the roof slab can be extracted from the entity alluded to by the attribute ‘*SweptArea*’ (of the roof ‘*IfcExtrudedAreaSolid*’ entity). Currently, only an ‘*IfcRectangleProfileDef*’ entity in this attribute can be processed by the ‘*ExtractIfcGeometry*’ class, but it could be extended to include other profile definitions. The ‘*IfcRectangleProfileDef*’ has attributes ‘*XDim*’ and ‘*YDim*’, which hold the length and width of each slab. These can be seen in Figure B.11. These dimensions are in the ‘*IfcRectangleProfileDef*’ coordinate system, and need to be adjusted to be in the ‘*IfcExtrudedAreaSolid*’ coordinate system. The attribute ‘*Position*’ of the ‘*IfcRectangleProfileDef*’ entity is used to transform ‘*XDim*’ and ‘*YDim*’. The ‘*Position*’ attribute holds an ‘*IfcAxis2Placement2D*’ entity, which gives the direction vector in the form of (Xx, Xy) of the ‘*IfcRectangleProfileDef*’ positive x-axis direction. As the positive y-axis direction is at 90 degrees to the x-axis, Equation B.4 can be used to determine the positive y direction as a vector in the form of (-Xy, Xx).

The converted '*XDim*' and '*YDim*' values can now be used to describe the slab shape. The '*IfcRectangleProfileDef*' entity placement is centric to the '*IfcExtrudedAreaSolid*' placement, as can be seen in Figure B.20. Therefore, slabs vertices can be described as: (*XDim* /2, *YDim* /2,0), (-*XDim* /2, *YDim* /2,0), (-*XDim* /2, -*YDim* /2,0), (*XDim* /2, -*YDim* /2,0). These slab dimensions are now ready for the third stage: the roof slab to be cut by the projected floor slab outline by another adaption of the Sutherland-Hodgman algorithm.



**Figure B.20** The placement of an '*IfcExtrudedAreaSolid*' and an '*IfcRectangleProfileDef*'.

This second adaption of the Sutherland-Hodgman algorithm is composed of the main program, and calls the functions '*inside()*', '*output()*' and '*intersection()*'. The main part of the program starts by checking the orientation of the polygon described by the projected floor slab. This should be anticlockwise, so the '*inside()*' function can later check if a vertex is inside a clip boundary or not. The orientation is checked by calculating the signed area of a polygon (Schneider and Eberly 2003), using Equation B.26. If the area is positive the polygon is anticlockwise, and if it is negative it is clockwise and needs to be reversed.

The main function then continues in a very similar way to Figure B.14, except that the clipping is performed in 2D as in Figure B.13. This is due to all the clip boundary and slab vertices involved lying on the  $z=0$  plane of the '*IfcExtrudedAreaSolid*' coordinate system. The clip boundary is simply the first two vertices from the projected floor '*a*' and '*b*'. Next the first and last vertices from the polygon become the '*S*' and '*P*' in Figure B.14. The main function then checks if the polygon vertices are inside or outside as in Figure B.15. Depending on the location of the points, the main function calls the '*intersection()*' and '*output()*' functions as described in Figure

B.14. The function continues to cycle through the roof slab polygon vertices. Once all the polygon vertices have been analysed, the next clip boundary is put together and the process repeats until there are no more clip boundaries.

The *'inside()'* function checks if a point is located on a line, or to its left (inside) or right (outside). Figure B.21 shows the side of a polygon being clipped by an edge *'E<sub>i</sub>'*. The polygon side can be called line *'P(t)'*, and  $P_0$  and  $P_1$  are the start and end points of that line. According to Foley et al. (1996) the parametric equation of *'P(t)'* can be expressed as:

$$P(t) = P_0 + (P_1 - P_0)t \quad \text{where } t=0 \text{ at } P_0 \text{ and } t = 1 \text{ at } P_1 \quad \text{(Equation B.27)}$$

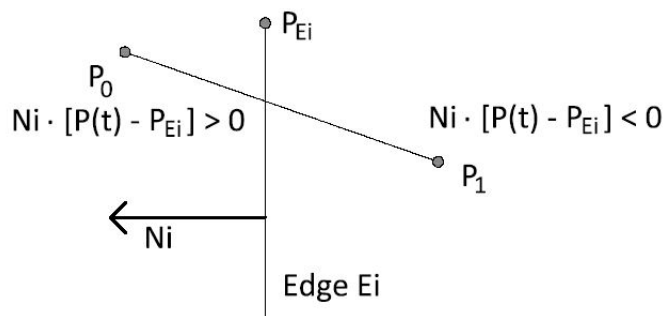
Additionally, Figure B.21 shows the normal *'N<sub>i</sub>'* of clipping edge *'E<sub>i</sub>'*, its, and a point on the edge *'P<sub>E<sub>i</sub></sub>'*. *'N<sub>i</sub>'* is at 90 degrees to the clip boundary, so it can be calculated using Equation B.4. A vector from *'P<sub>E<sub>i</sub></sub>'* to any hypothetical point on the line  $P(t)$  has the form:

$$P(t) - P_{E_i} \quad \text{(Equation B.28)}$$

In order to check if that hypothetical point is on the left or right side of edge *'E<sub>i</sub>'*, the following dot product is calculated:

$$N_i \bullet [P(t) - P_{E_i}] \quad \text{(Equation B.29)}$$

If the answer is equal to zero, the point is located on the edge *'E<sub>i</sub>'*. If the answer is greater than zero, the point is on the left side the clip boundary. If the dot product is smaller than zero, it is on the right side the clip boundary.



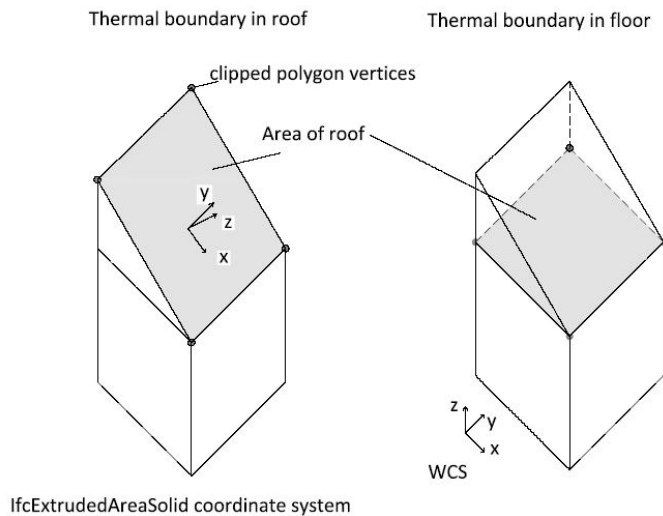
**Figure B.21** Points inside and outside of a clipping boundary  $E_i$ , adapted from (Foley et al. 1996).

The *'intersect()'* function uses Equation B.27 to determine a point of intersection between a clip edge and vertices of the slab polygon. If these vertices are  $P_0$  and  $P_1$  in Figure B.21, it can be seen that the intersection is where  $N_i \cdot [P(t) - P_{E_i}] = 0$ . The

line ' $P(t)$ ' from Equation B.27 is substituted into  $N_i \cdot [P(t) - P_{Ei}] = 0$ , and the result is rearranged to give:

$$t = \frac{N_i \cdot [P_0 - P_{Ei}]}{-N_i \cdot D} \text{ where } D = P_1 - P_0. \quad \text{(Equation B.30)}$$

Once calculated, the value of ' $t$ ' can be substituted back into Equation B.27 to give the point of intersection. The resulting points of intersection and points from the polygon which are inside the clip boundary are stored in a list, as they form the shape of the roof slab without an overhang. This list can now be processed depending on the location of the thermal boundary. If the thermal boundary is the roof slabs themselves, the area of a slab is calculated from the slab polygon using Equation B.26 using its  $x$  and  $y$  coordinates. This is due to the  $z$  coordinates all being equal to zero as the vertices are defined in the roofs local placement coordinate system. If the thermal boundary is in the top floor, the slab polygon vertices are transformed to the WCS, and the area is worked out using Equation B.26 using its  $x$  and  $y$  coordinates, as they will give the area under a slab on a horizontal plane where  $z = 0$  in the WCS. These two scenarios are illustrated in Figure B.22.



**Figure B.22 Thermal boundary location affecting the area of the roof needed.**

The thermal boundary location can be determined from the entity '*IfcRelSpaceBoundary*'. This describes the relationship between '*IfcElement*' and '*IfcSpace*' entities. Spaces are assumed to be thermal zones in this project. Therefore, if the roof being analysed is found to share a boundary with an '*IfcSpace*', it is assumed that the thermal boundary is in the roof. Otherwise, it is assumed that the thermal boundary is in the highest floor slab. As the method in this section is used to analyse every roof in an IFC file, the tool can handle different roofs in the same model.

### B.3.6 EXTRACTING THE TREATED FLOOR AREA: IFCSPACE AND IFCWINDOW

The TFA is calculated based on the area of spaces and window reveals. The '*ExtractingIFCGeometry*' has implemented some of the rules which describe if a space should be counted as TFA. The user still has the responsibility of defining spaces so they are suitable for the TFA calculation. An example is stairs and landings/corridors need to be drawn as separate spaces, as the landing/corridor area is eligible to be included in the TFA area, but the staircase area is not.

#### B.3.6.1 TFA from IfcSpace

In the IFC2x3-TC1 schema, an '*IfcSpace*' is defined as an '*area or volume bounded actually or theoretically*'. This makes it a suitable candidate for describing the geometry necessary for TFA calculations as both the area and height of a space is given. Tools such as Revit Architecture let the user define the volumes of '*rooms*', which are exported to an IFC file as separate '*IfcSpace*' entities.

The '*ExtractingIFCGeometry*' class cycles through all available '*IfcSpace*' entities in an IFC file. The entity '*IfcSpace*' is a subtype of '*IfcProduct*', so it inherits the '*Representation*' and '*ObjectPlacement*' attributes, where the shape representation entity '*IfcShapeRepresentation*' is related to a space with the '*Representation*' attribute. In order to describe an '*IfcSpace*' in 3D, representations of the type '*SweptSolid*' and '*Clipping*' can be used. More information about these entities has been given in the Section B.3.1.3 Extracting Wall Geometry. The '*ExtractingIfcGeometry*' class currently handles only the '*IfcShapeRepresentation*' entity, which has a '*RepresentationType*' of '*SweptSolid*' and '*Brep*'. It could be however easily extended to handle the '*Clipping*' representation type, using the principles for extracting geometry for a wall.

The process involves calculating a temporary area which then needs to be further processed using rules. For a '*SweptSolid*' representation type, one of the '*IfcShapeRepresentation.Items*' is an '*IfcExtrudedAreaSolid*' (Liebich 2009). This has the attribute '*SweptArea*', which relates to an '*IfcProfileDef*' entity. Three subtypes of this entity are '*IfcRectangleProfileDef*', '*IfcArbitraryClosedProfileDef*' and '*IfcArbitraryProfileDefWithVoids*'. If the entity '*IfcRectangleProfileDef*' is stated, a temporary area can be calculated by multiplying its attributes '*XDim*' and '*YDim*'. If the entity '*IfcArbitraryClosedProfileDef*' is used instead, the process is more complicated. This entities attribute '*OuterCurve*' contains the boundaries of the swept solid, which refer to the abstract entity '*IfcCurve*'. A standard subtype used in its place is the '*IfcPolyline*', which holds a list of '*IfcCartesianPoint*' entities. Once

these points are extracted, a temporary area can be calculated using Equation B.26. If the entity '*IfcArbitraryProfileDefWithVoids*' is stated, the outer curve area is calculated using the same method as for the '*IfcArbitraryClosedProfileDef*', but there is also an inner curve attribute ('*IfcArbitraryClosedProfileDef.InnerCurves*') whose area has to be calculated and taken away from the outer curve. The inner curve can be described by a set of '*IfcPolyline*' entities, similarly to the outer curve. The inner curve areas are therefore calculated individually using the method described above, and taken away from the outer curve area.

A '*Brep*' representation type will result in the '*IfcShapeRepresentation.Items*' attribute to hold either an '*IfcFacetedBrep*' or an '*IfcFacetedBrepWithVoids*' entity (Liebich 2009). Only the former is currently processed by PassivBIM. The '*IfcFacetedBrep*' describes a shape where all faces are planar and the edges are straight lines. The '*IfcFacetedBrep*' has the attribute '*Outer*' which is described by the entity '*IfcClosedShell*'. This has an attribute '*CfsFaces*' which holds a set of '*IfcFace*' entities. '*IfcFace*' has the attribute '*Bounds*', which holds a set of '*IfcFaceBound*' entities or its subtypes. One of the common subtypes is '*IfcFaceOuterBound*', which has the attribute '*Bound*'. The '*Bound*' attribute holds an '*IfcLoop*' or one of its subtypes. A common subtype is '*IfcPolyloop*' which has the attribute '*Polygon*'. '*Polygon*' can hold a list of three or more '*IfcCartesianPoint*' entities. These points are analysed against two conditions to determine if the room area represented by the '*Brep*' shape should be part of the TFA. First, all the coordinates describing an individual '*IfcPolyloop*' are tested to see if their z coordinates are equal to 0. This is to identify faces which describe the bottom area of a shape. Secondly, the z-coordinates are tested to see if any are above 0, but below 1000. This rule assumes that the units of the project are in millimetres, and would need to be updated in the future to test the units of the project. The purpose of this rule is if part of a room is below 1m, that part of a room area should not be counted towards the TFA. At the moment, if PassivBIM finds any part of the room between 0-1000mm, the whole room area is rejected for inclusion in the TFA calculation. This is currently a limitation, and needs to be further developed. Finally, if an '*IfcPolyloop*' has faces on the z=0 plane and all the coordinates of the faces are above 1500 millimetres, the area can be added to the main temporary area.

Now that a total temporary area has been calculated for a space, it needs to be adjusted based on the following rules for calculating the TFA (Hopfe and McLeod 2010):



- 100% of the area of a habitable space is included in the TFA calculation if it is higher than 2m.
- 60% of the area of a space such as the basement or technical room can be included in the TFA
- 50% of the area of a space can be included if its height is between 1 and 2m.
- Do not include areas such as the elevator and stairs.
- Window reveals are only included if their depth is greater than 0.13m and the reveal extends all the way to the floor level

For the *'Brep'*, the first and third rule has already been checked. For the *'SweptSolid'*, applying the first and third rule includes checking the height of the space by examining the *'Depth'* attribute of the associated *'IfcExtrudedAreaSolid'*. For the other two rules, the percentage cannot be extracted from the geometry so the *'Description'* attribute of *'IfcSpace'* has been used to decide if an area should be reduced to 60% or not included at all. This attribute is optional, and can be filled with data in Revit Architecture using the *'comment'* box when a *'room'* has been selected. A better solution would be if *'IfcSpace'* was extended with an attribute which could be used to hold this data directly. For the last rule, the area has to be calculated from the *'IfcWindow'* entity, so it can be added to the temporary area and then adjusted to comply with the other rules.

#### **B.3.6.2 TFA from IfcWindow**

As part of the reveal calculation, all the windows are assessed to see if they are next to the thermal space being analysed, if they extend to a floor and if the reveal is greater than 0.13m. Testing to see if a window reveal extends to the floor level starts by collecting a list of *'IfcBuildingStorey'* entities and establishing their height above ground level. This is done by transforming the homogenous coordinate (0,0,0,1) from all the *'IfcBuildingStorey'* coordinate systems to the WCS, and extracting the z coordinate. The placement of the window now needs to be checked against these heights. The homogenous coordinate representing the origin of each window coordinate system (0,0,0,1) is transformed for each window into the WCS, and the z coordinate is checked against all the building storey heights. At the moment this method works with tolerance of 1cm, but this can be updated with a more precise figure from the PHI in the future.

A window is next tested to confirm if it is next to the thermal space being examined. This information can be extracted from the '*IfcRelSpaceboundary*' entity. Its attribute '*RelatedBuildingElement*' holds building elements, and '*RelatingSpace*' holds spaces. If a relationship is found between the window and space that are being examined, its reveal depth can be tested.

The '*IfcWindow*' entity is placed differently to building elements such as walls, as it has to fill a void. This void is created by an '*IfcOpeningElement*' entity. The window fills the opening element using the relationship '*IfcRelFillsElement*'. As a result, the window placement is usually placed relatively to an opening elements coordinate system. An '*IfcWindow*' is a complex shape, as it is not a just a polygon which has been extruded or clipped but may be composed of many different objects. One of the '*RepresentationType*' attributes of a windows '*IfcShapeRepresentation*' entity can be '*MappedRepresentation*'. An '*IfcShapeRepresentation*' of this type is recommended to refer to an '*IfcMappedItem*' (Liebich 2009). This entity has the attributes '*MappingSource*' and '*MappedRepresentation*'. If the '*MappedRepresentation*' holds an '*IfcShapeRepresentation*' with the representation type of '*SweptSolid*', the '*IfcShapeRepresentation*' will hold '*IfcExtrudedAreaSolid*' entities in the '*Items*' attribute. In summary, this type of window is a collection of shapes which have been extruded in some direction. If the y coordinates of each objects placement before and after the extrusion are compared in the '*IfcOpening*' coordinate system, it is assumed that the smallest value is the window reveal. There is no convention to the placement of the '*IfcOpeningElement*', but it is mentioned that a preferable style is to have e.g. the opening z-axis pointing in the same direction as the wall z-axis (Liebich 2009). After examining Revit generated IFC files, it can be said that openings have all three axis pointing in the same direction as the walls they are placed in, so the y coordinate is suitable. The depth of a window is designated along the y-axis.

This process of calculating the smallest y coordinate is as follows:

- A Transformation matrix  $M_{IfcOpeningElement \leftarrow IfcExtrudedAreaSolid}$  is generated. This is the product of a)  $M_{IfcOpeningElement \leftarrow IfcWindow}$ , which is calculated using the '*Position*' attribute of the '*IfcWindow*' and b)  $M_{IfcWindow \leftarrow IfcExtrudedAreaSolid}$ , which is calculated using the '*Position*' attribute of an '*IfcExtrudedAreaSolid*' entity.

- The coordinate marking the location of the start of the polygon extrusion 'SE' is the origin of its placement. It needs to be in the form of a homogenous coordinate so it can be transformed between coordinate systems later, so it has the value of (0, 0, 0, 1).
- The coordinate describing the location of the end of the extrusion 'EE' is the origin of the polygon, with the product of the extrusion length and direction added to it. This coordinate 'EE' will also need to be in the form of a homogenous coordinate. The extrusion depth and direction is extracted from the attributes 'Depth' and 'ExtrudedDirection' of the 'IfcExtrudedAreaSolid' entity which is related to the polygon.
- The points 'EE' and 'SE' are transformed into the opening element coordinate system, and stored in a list. This is so the distance between the outside edge of the opening (and also the wall) to the point 'EE' and 'SE' can be calculated.
- After all the 'IfcExtrudedAreaSolid' entities which describe the window shape representation have been processed, the smallest y coordinate of all the points is the reveal length.

The window reveal area is now calculated by multiplying the 'OverallWidth' attribute of 'IfcWindow' with the reveal length.

This concludes the steps taken by 'ExtractIfcGeometry' to extract geometry from an IFC file.

## Appendix C PHPP ANNUAL HEAT DEMAND

### CALCULATION

The main annual energy demand calculation is based on EN 13790, and involves balancing heat gains (internal and solar) to heat losses (ventilation and transmission). The process for the annual calculation is described in the PHPP 2007 handbook (PHI 2007). In this calculation, the transmission heat losses  $Q_T$  are calculated by Equation C.1 where 'A' and 'U' are the building element area and U-value respectively, ' $f_T$ ' is the reduction factor for reduced temperature differences and  $G_t$  is the temperature difference time integral.

$$Q_T = A * U * f_T * G_t \quad \text{(Equation C.1)}$$

The values of 'A' and 'U' are calculated for each building element. The area is calculated based on geometry data, and the U-value is calculated after the user enters construction materials. The value of ' $G_t$ ' is calculated based on climate data, and a value for ' $f_T$ ' is chosen based on individual building elements temperature zones. These temperature zones are standard for specific building elements, for example the 'North Windows' has the temperature zones 'A'.

The ventilation heat losses ' $Q_V$ ' are calculated using Equation C.2, where ' $n_V$ ' is the effective air exchange rate, ' $V_V$ ' is the volume of the ventilation system and 'c' is the specific heat capacity of air.

$$Q_V = n_V * V_V * c * G_T \quad \text{(Equation C.2)}$$

The value of ' $n_V$ ' is calculated based on the average air exchange of the ventilation system. ' $V_V$ ' is the product of the Treated Floor Area ' $A_{TFA}$ ' and the average room height and 'c' is equal to 0.33Wh/(m<sup>3</sup>K).

The total heat losses are calculated by adding ' $Q_T$ ' and ' $Q_V$ '. The next step is to calculate the heat gains. The internal heat gains ' $Q_I$ ' are calculated as:

$$Q_I = \frac{kh}{d} * H_T * q_I * A_{TFA} \quad \text{(Equation C.3)}$$

Where ' $kh/d$ ' is equal to 0.024, ' $H_T$ ' is the length of the heating period, and ' $q_I$ ' is the internal gains estimated for standard living conditions. These conditions and the appropriate heat gain value are given in Table C.1 (PHI 2007).

**Table C.1 Internal heat gains based on living conditions of buildings.**

Standard living condition	Internal heat gain $Q_i$ (W/m <sup>2</sup> )
Single family home, multifamily home, terraced houses	2.1
Assisted living facilities	4.1
Office and administration buildings	3.5
Schools	2.8

Another heat gain is due to solar heat gain ' $Q_S$ '. It is calculated using Equation C.4, and uses a reduction factor ' $r$ ' which depends on the window area to frame, shading, dirt and the tilted incidence angle of radiation through the window. It also uses the value ' $g$ ', which is the degree of solar energy transmitted through glazing normal to the irradiated surface. It also uses the value ' $A_w$ ', which is the window opening area and the total radiation ' $G$ '.

$$Q_S = r * g * A_w * G \quad \text{(Equation C.4)}$$

The free heat gains ' $Q_F$ ' can now be worked out, which is the sum of ' $Q_i$ ' and ' $Q_S$ '. From this and ' $Q_L$ ' the free heat utilisation factor ' $n_G$ ' can be worked out, using Equation C.5.

$$n_G = \frac{1 - \left(\frac{Q_F}{Q_L}\right)^5}{1 - \left(\frac{Q_F}{Q_L}\right)^6} \quad \text{(Equation C.5)}$$

From this, the useful heat gains ' $Q_G$ ' can be calculated, as the product of ' $Q_F$ ' and ' $n_G$ '. Finally, the annual heat demand ' $Q_H$ ' can be calculated using Equation C.6. Dividing this by the ' $A_{TFA}$ ' gives the specific annual heat demand ' $q_H$ '.

$$Q_H = Q_L - Q_G \quad \text{(Equation C.6)}$$

The upper limit for ' $q_H$ ' equation is 15kWh/(m<sup>2</sup>a), but a Passivhaus can also be alternatively certified using the peak load as criteria. The ' $Q_H$ ' can also be calculated using a monthly method, which uses all the energy concepts from above but also needs the thermal storage capacity, which is entered by the user.

## Appendix D OUTLINE OF PHPP WORKSHEETS

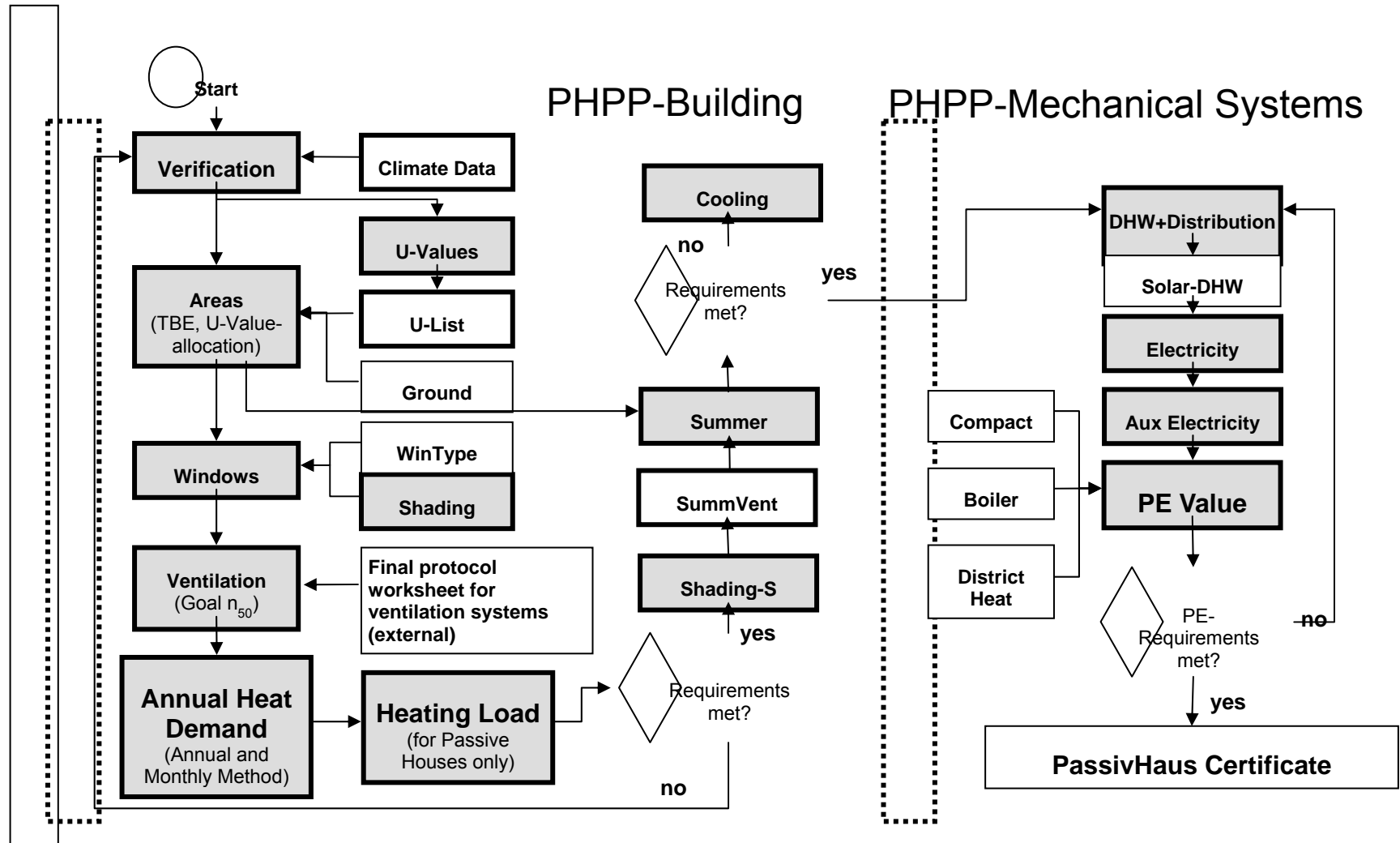


Figure D.1 The relationships between different worksheets in PHPP. Source: CEPH material, BRE, 2013

## Appendix E USABILITY TESTING PRESENTATION





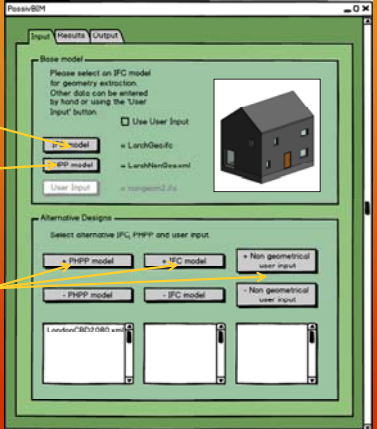
<p><b>PassivBIM: Usability Testing</b> Ph.D. student: Alexandra Cemesova Supervisors: Dr. Hopfe and Prof. Rezgui</p> <p> </p> <p>2/13</p>	<p><b>Contents</b></p> <ul style="list-style-type: none"><li>○ Study 1<ul style="list-style-type: none"><li>○ Revit</li><li>○ Mock-up Interface - Input</li><li>○ Mock-up Interface - Results</li><li>○ Mock-up Interface - Output</li></ul></li><li>○ Study 2<ul style="list-style-type: none"><li>○ Revit</li><li>○ Mock-up Interface - Input</li><li>○ Mock-up Interface - Results</li><li>○ Mock-up Interface - Output</li></ul></li></ul> <p>2/13</p>
<p><b>Study 1</b> IFC and PHPP input, informing design</p> <p>3/13</p>	<p><b>Revit</b></p> <ul style="list-style-type: none"><li>○ Revit model is created :<ul style="list-style-type: none"><li>○ Rooms defined for TFA</li><li>○ External walls labelled as such</li></ul></li><li>○ IFC file is exported</li></ul> <p> </p> <p>4/13</p>

Figure E.1 Slides 1-4 of usability testing presentation.

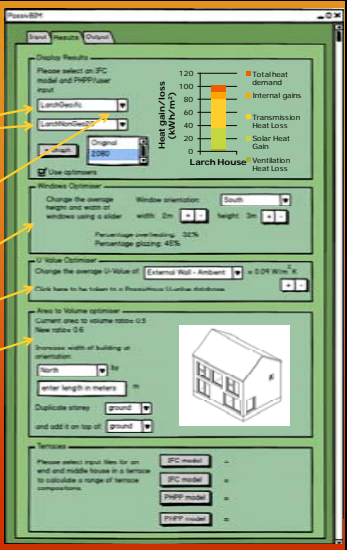
### Mock-up Interface (Input)



- Geometry, choose IFC model
- Non-geometric data: PHPP model
- For alternative designs, enter XML, IFC or user input

5/13

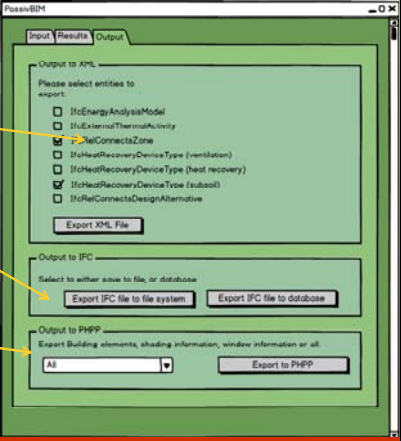
### Mock-up Interface (Results)



- Select IFC and XML file
- Add graph to list of results
- Optimise:
  - window areas
  - U values
  - Area to volume

6/13

### Mock-up Interface (Output)



- Certain entities can be exported to an XML file.
- IFC file can be generated
- Information can be exported straight to PHPP

7/13

### Case Study 2

User input and masterplanning

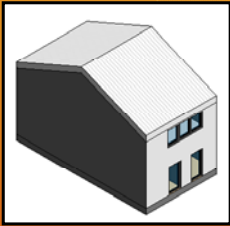
8/13

Figure E.2 Slides 5-8 from usability testing presentation.



### Revit

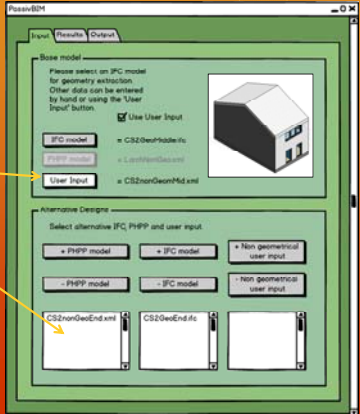
- 2 Models:
  - Middle house (2 party walls)
  - End house (1 party wall)
- Areas created for TFA
- External walls labelled as external
- Party walls labelled as external, but comment = '0'



9/13

### Mock-up interface (Input)

- Non-geometrical data input using 'user Input' button.
- Alternative IFC models



10/13

### Mock-up Interface (Results)

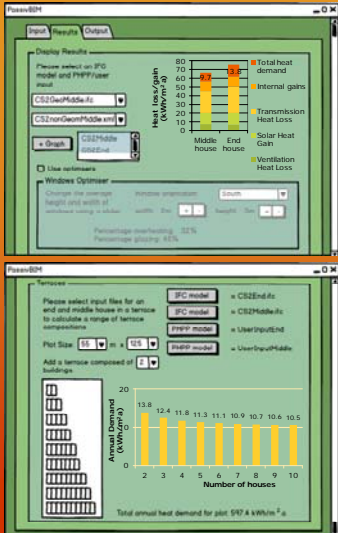
- Results displayed for 2 cases
- Terraces can be predicted from middle house and end house:

Building composition:

234

End house


 Middle house



11/13

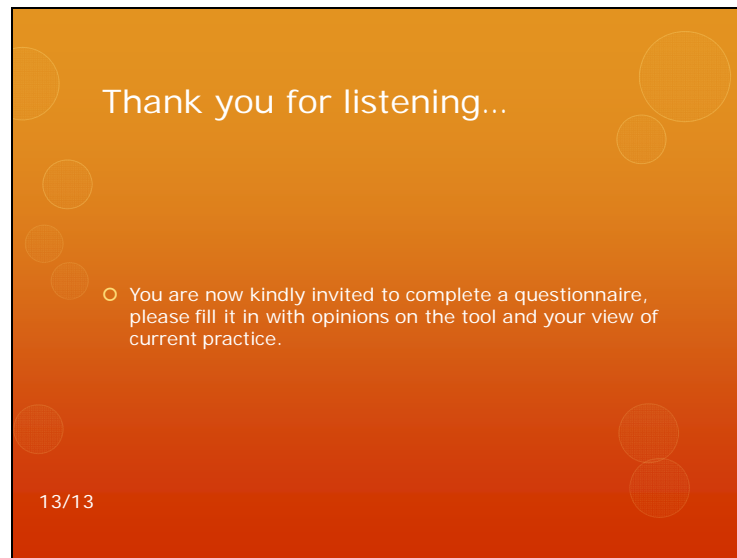
### Mock-up Interface (Output)

- Same as Case Study 1



12/13

Figure E.3 Slides 9-12 from usability testing presentation.



**Figure E.4 Slides 13 from usability testing presentation.**

## Appendix F USABILITY TESTING SURVEY

### BIM, PHPP and the PassivBIM tool

#### General questions

**1. Would you agree with the statement that the automation of some of the data input into PHPP could save you time?**

Yes

No

Other (please specify)

**2. Would you agree that a tool which could instantly calculate the PHPP energy demand of a BIM model would enhance the design process?**

Yes

No

Maybe

If you stated 'No' or 'Maybe' please elaborate below:

**3. Do you or your practice use any automation of data entry between BIM /CAD tools and energy analysis tools?**

Yes - We have an in house solution.

Yes - We copy and paste schedule information from BIM tools

No

Other (please specify)

**4. In your opinion, are some PHPP input calculations, such as the Treated Floor Area, open to interpretation and therefore error?**

Yes

Only some parts

No

If you specified 'Yes', or 'Only some parts' please give examples below.

Next

Figure F.1 Questions 1-4 from online survey

## BIM, PHPP and the PassivBIM tool

### PassivBIM Feedback

**5. Could you envisage a tool such as PassivBIM being adopted in your practice?**

- Yes
- No
- Depends on the individual architects preference

Other

**6. Do you agree that a tool such as PassivBIM could save the user time and reduce error?**

- Time only
- Error only
- Both
- None
- Other

Other (please specify)

**7. Do you think that your workflow would benefit from streamlining data transfer from BIM to PHPP using PassivBIM?**

- Yes
- No
- Other

Other (please specify)

Figure F.2 Questions 5-7 from online survey

**8. Please rate the following features of PassivBIM using a scale of 1-5 (where 1 is not useful and 5 is very useful):**

	1	2	3	4	5
Visualization of building	<input type="radio"/>	<input type="radio"/>	<input type="radio"/>	<input type="radio"/>	<input type="radio"/>
Calculation of annual heat demand after all data imported	<input type="radio"/>	<input type="radio"/>	<input type="radio"/>	<input type="radio"/>	<input type="radio"/>
Exportation of geometry data processed from an IFC file to PHPP	<input type="radio"/>	<input type="radio"/>	<input type="radio"/>	<input type="radio"/>	<input type="radio"/>
Window optimizer	<input type="radio"/>	<input type="radio"/>	<input type="radio"/>	<input type="radio"/>	<input type="radio"/>
U-value optimizer	<input type="radio"/>	<input type="radio"/>	<input type="radio"/>	<input type="radio"/>	<input type="radio"/>
Area to Volume optimizer	<input type="radio"/>	<input type="radio"/>	<input type="radio"/>	<input type="radio"/>	<input type="radio"/>
Exportation to IFC	<input type="radio"/>	<input type="radio"/>	<input type="radio"/>	<input type="radio"/>	<input type="radio"/>
Exportation to XML if the resulting files were stored in a database accessible by others, so the process supports collaboration	<input type="radio"/>	<input type="radio"/>	<input type="radio"/>	<input type="radio"/>	<input type="radio"/>

**9. Please describe any features you feel that are missing.**

**10. If the PassivBIM tool was adapted based on your feedback, would you consider it's adoption?**

- Yes
- No
- Maybe

If maybe please specify why

**Figure F.3 Questions 8-10 from online survey**

## Appendix G PARTICIPATION INFORMATION SHEET FOR USABILITY TESTING

---

### *Participant Information Sheet*

---

#### **Study Title: Presentation on a mock-up of the PassivBIM system**

---

You are being invited to take part in a research study. Before you decide it is important for you to understand why the research is being done and what it will involve. Please take time to read the following information carefully and discuss it with others if you wish. Ask me if there is anything that is not clear or if you would like more information. Take time to decide whether or not you wish to take part.

Thank you for reading this.

#### **What is the purpose of the study?**

---

There are still issues with interoperability between Building Information Modelling (BIM) authoring tools and Building Performance Simulation (BPS). A system called PassivBIM has been developed which facilitates the transfer of data from BIM tools to BPS. The BPS tool in question is the Passive House Planning Package (PHPP). This tool is used to certify buildings to the Passivhaus standard.

The aim of this study is to establish the usability of the prototype PassivBIM system. The study should take 15-20 minutes in total.

#### **Why have I been chosen?**

---

The study is aimed at leading architects and certified Passivhaus designers. The aim is to have between 4-8 participants in total.

#### **Do I have to take part?**

---

It is up to you to decide whether or not to take part. If you do decide to take part you will be given this information sheet to keep and be asked to sign a consent form. If you decide to take part you are still free to withdraw at any time and without giving a reason.

#### **What will happen to me if I take part?**

---

This is the only part of the research you will be involved in, so after the presentation and some questions you will not be contacted again.

#### **What about confidentiality?**

---

The feedback will be stored in MsWord documents with no data linking it back to you.

**Figure G.1 Participant Information sheet page 1**

### **What do I have to do?**

---

I will present the user interface of the PassivBIM system, and some typical inputs and outputs using two existing Passivhaus buildings. You are then warmly invited to give feedback on the capabilities of the prototype.

### **Are there any risks?**

---

There are no risks.

### **What will happen to the results of the research study?**

---

The PassivBIM is part of a Ph.D., and a summary will be published in the thesis in the next half a year. You will be able to access the results by downloading a copy of the Thesis from Cardiff University. Your name will not be included in the Thesis.

### **Who is organising and funding the research?**

---

The research is organised by a Ph.D student Alexandra Cemesova, and she is funded by EPSRC and BRE Trust.

### **Contact for Further Information**

---

For further information, please contact Alexandra Cemesova at: [cemesovaa@cardiff.ac.uk](mailto:cemesovaa@cardiff.ac.uk).

Participant Information Sheet

Version 1

18/2/2013

**Figure G.2 Participant Information sheet page 2**

## CURRICULUM VITAE

Alexandra Cemesova was born on the 16<sup>th</sup> January 1989 in Bratislava, Slovakia, She graduated 2010 with a First Class Honours degree in Architectural Engineering at Cardiff University. During the degree, she received the following awards:

- **David Lenczner Prize** for the 'best overall performance in Architectural Engineering', in 2010.
- **Norman Thomas Design Prize** for 'the best design work', in 2009.
- **Edmund Nuttall Prize** for 'the best group work in structural design', in 2009.

During her Ph.D. studies, she was also awarded the David Douglas Award, for an academic paper and a presentation given to the Board of Directors of the South Wales Institute of Engineers in 2013.