

Affordable building system from locally grown softwoods Ty Unnos (house in a night)

prototypes: system and componentry, Smithsonian Pavilion, Classroom & 'passiv' longhouse



Affordable building system from locally grown softwoods - Ty Unnos (house in a night)

prototypes: system and componentry, Smithsonian Pavilion, Classroom & 'passiv' longhouse

a. **Year of output:** 2008-2012

b. **Type of output**

vii. Building system developed and tested through prototypes (componentry and 3 completed buildings)

c. **Title of the output:**

Ty Unnos : The development of a low-impact, affordable building system from locally grown softwood.

Funders/Clients

Countryside Council for Wales (CCW), Forestry Commission Wales funded feasibility study £15k

Technology Strategy Board funded Low Impact building Systems £250k

Welsh Government funded Ty Unnos proto-typical Pavilion

for the Smithsonian, Washington 2010 £75k

Blaenau Gwent District Council funded Environmental Resource Classroom, Ebbw Vale £315k

Blaenau Gwent District Council funded Ty Unnos 'passiv' longhouse, Ebbw Vale £250k

I. Each of the following is required **where applicable** to the output:

a. **Co-authors:** Coombs.S. Thomas. R

b. **Interdisciplinary research**

The panel should note that this is the product of interdisciplinary work involving a range industrial partners.

c. **The research group**

Design Research Unit of the Welsh School of Architecture (DRUw)

e. **Request to 'double weight' the output:** for outputs of extended scale and scope, the submitting institution may request that the sub-panel weights the output as two (see paragraphs 123-126).

Aims and objectives

The primary aim of this research, broadly entitled Ty Unnos - 'House in one night', was to design, fabricate and prototype and mainstream a solution for the use of homegrown Sitka spruce in affordable housing determined by the following factors:

To convert a locally grown, low value crop with poor structural and dimensional characteristics into a high value construction system that meets the technical, sustainable and architectural demands for contemporary timber systems.

This is set in the context of the need for such a system and the potential ecological benefits to the indigenous forest and the rural economy and the nature and form of the contemporary rural dwelling.

Methodology

The research has been conducted through a series of prototypes, produced over a four year period, primarily in a number of significant stages that progressively develop and demonstrate the system.

The development of the architectural concept to fully integrated system through four exemplar prototypes:-

- Integrated componentry
- Pavilion representing Wales, for the Smithsonian Folklife Festival in Washington DC;
- Environmental Resource Classroom in Ebbw Vale, Blaeanau Gwent, Wales for the use of the Gwent Wildlife Trust.
- A low energy, 'passiv longhouse' in Ebbw Vale. Blaenau Gwent, Wales.

Dissemination

This has taken place in three main ways as follows:-

- through demonstration - the physical presence of the proto-types themselves at national and international exposition – The Smithsonian Folk Festival, Washington, USA , The Royal Welsh Show, Gwent Wildlife Trust, The BRE Welsh Future Homes Exhibition at Ebbw Vale.
- through publication in the form of conference papers, architectural journals and Best Practice Papers produced by national organisations.
- through architectural competition, design and innovation awards such as RIBA Awards, Eisteddfod, Cardiff University Innovation Awards and CIOB Research Awards for Architecture.
- through RIBA Presidents Awards for Outstanding University based Research 2013

Authorship

Wayne Forster DRUw (Principal Investigator)
Steve Coombs DRUw (Design Research Associate)
Rob Thomas DRUw (PhD Researcher)

In collaboration with the following industrial partners
Coed Cymru
Kenton Jones
Cowley Timber
Burroughs

Statement of Significance

Tŷ Unnos Awards

Timber Research and Development Association (TRADA) 75th anniversary research competition winner 2008.

Cardiff University Innovation Award 2009.

Chartered Institute of Building International Award for Architecture and Surveying 2009

Royal Academy Summer Exhibition Award: Ebbw Vale Environmental Resources Centre (ERC)

Tŷ Unnos Pavilion display at the Smithsonian Folklife Festival featuring Welsh life Washington DC 2009

National Eisteddfod for Wales Wrexham Plaque of merit for Architecture for the ERC at Ebbw Vale 2011

TRADA Wood Awards ERC entry short list 2010.

InnovaWood European Forest and Timber Network 'Laureate Prize' for Ebbw Vale Visitor Centre 2011.

Technology Strategy Board Driving Innovation: Home grown Welsh eco house. Case Study. Ebbw Vale Visitor Centre, TSB 2010.

ACE Engineering Excellence Awards: Tŷ Unnos – A Home grown Timber Solution: Research Studies and Consulting 2012

ERC Shortlisted for an RIBA Award 2011

RIBA President's Awards for Outstanding University-located Research 2013 Commended

Statements of Support

"Tŷ Unnos deserves wider attention to increase both the affordability and range of the product and to demonstrate an exciting response from rural Wales to the key challenge climate change poses to our times."

Jane Davidson - Minister for Environment Sustainability and Housing Welsh Assembly Government 2007 – 2011. Director, INSPIRE, University of Wales, Trinity Saint David 2012.

"I am delighted to have been involved in the approval process for the innovative project".

Hugh Mansfield Williams TRADA

The judges commended this research for being ahead of its time and with significant levels of rigour, integrity and value. This accessible work was admirable in the researchers' adherence to the research aims, while accommodating the briefs and needs of the project sponsors.

RIBA President's Awards for Outstanding University-located Research 2013

1.1 Introduction

1.1.1 Context

The research meets a number of needs – how to exploit a technically poor low value resource to make a complete sustainable and low impact building system, whilst enhancing the ecology of the forest and promoting the rural economy and providing architectural exemplars for the contemporary rural dwelling.

Sitka spruce was planted, following clear felling over 50 years ago, to produce pit props for the thriving mining industry in Welsh plantations because of its liking for a mild and wet climate and its ability to establish in peaty upland soils. There are now 150,000 hectares of coniferous plantations which produce around a million tonnes of softwood per annum.

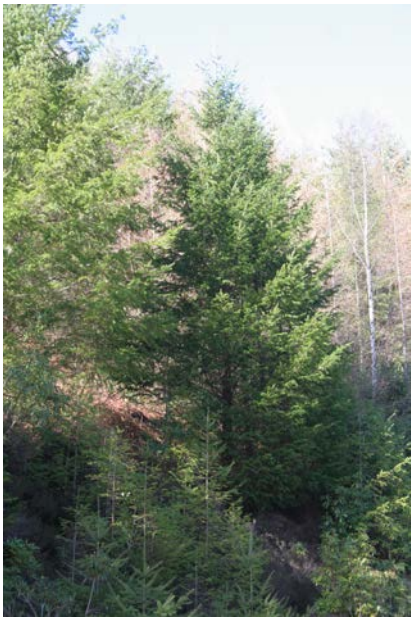

Welsh Sitka Spruce trees



Welsh forest management



1.1.2 Affordable housing and the rural dwelling

A need has been identified in the UK and Wales in particular for affordable rural housing. If there is a distinctive architecture of Wales it is the vernacular dwelling in the landscape. The traditional skills of siting, orientation, form and stringent use of local materials has been lost in favour of a range of generic placeless developments.



'Better homes for people of Wales'



This has been paralleled by increasing environmental requirements of construction materials, components and whole building performance. As a result of improved energy performance through the lifetime of a building the carbon footprints and embodied energy of materials is of increasing importance.

At present all of the modern timber frame manufacturers in Wales (and the UK) use imported softwoods because of the greater stability and superior strength of slow grown softwood from cooler and drier climates. If a system was to

useful it would need to stabilise the main structural components and eliminate the need for conventional trussed rafters. This would require a radical departure from existing practice.

1.1.3 Timber prefabrication

As a result of the Latham (1994) and Egan (1995) reports and government initiatives such as IMI and MMC there has been an increased drive towards off-site construction in UK housing as a means to improve cost, quality and time. This and the absence of a sophisticated timber frame industry prompted the importation of Scandinavian, German, Austrian and Polish systems.

While the various panel systems in Europe are an efficient and innovative solution they rely on 'high-tech', highly capitalized factories and machinery dedicated to the European crop. There are many variants of this system, but the more advanced structurally insulated panels (SIP) offer the option of creating a watertight shell, often erected in 2-3 days, prior to the installation of services and external claddings.

Currently, the Welsh MMC supply chain is immature compared to that in the rest of the UK. Many of the Welsh MMC manufacturers are receiving larger orders from hotel and fast food retailers outside Wales than from construction and housing companies within Wales. With the correct input, many of the current MMC suppliers have the potential to develop more focussed and advanced construction systems.

1.2 Research aims and objectives

In 2007, a partnership led by Coed Cymru with the Design Research Unit Wales at the Welsh School of Architecture, the School of the Environment and Natural Resources, University of Wales, Bangor and Cowley Timberwork Ltd funded by the Countryside Council for Wales (CCW) and the Wales Forest Business Partnership was established to undertake a feasibility study with a focus on domestic scale architecture. This was further enhanced in 2009 with significant funding from the Technology Strategy Board for a further 2 years of research, development and prototyping, to establish an affordable housing construction system and supplemented by funding from Blaenau Gwent District Council for two buildings on the former steel works at Ebbw Vale – an Environmental Resource Classroom for Gwent Wildlife Trust and a Visitor Centre for the Welsh Future homes Exposition on the same site. This was won by DRUw following an open Design Competition.

1.2.1 Research aim

The primary aim of the study, broadly entitled Ty Unnos - 'House in one night', was to design, fabricate and prototype a solution for the use of homegrown Sitka spruce in an elegant architectural solution for affordable housing determined by the following architectural and technological factors:

- the use of standardised sizes and sections of Sitka spruce and other softwoods available from the local sawmills;
- to use low-tech engineering methods that complimented the available skills and plant to reduce costs and enable quick mobilisation; and
- to focus on a domestic scale superstructure system.
- to produce a system that promoted high architectural design solutions and low carbon performance
- to provide architectural exemplars for the contemporary rural house based on principles of Tradition and Innovation.

1.2.2 Research method

The research was to be conducted as a series of prototypes primarily through a number of significant projects:-

- The development of the construction system through prototyping components at scale model and 1:1, as well as structural testing and small scale test structures;

The construction of a temporary pavilion, for the Smithsonian Folklife Festival in Washington DC;
The design, fabrication and construction of an Environmental Resource Classroom in Ebbw Vale; and
The design, fabrication and construction of a demonstration, low energy, contemporary longhouse in Ebbw Vale.

Each prototype had its own set of test criteria that developed progressively from the previous study.

1.3 Precedent and feasibility

Precedent studies revealed three different architectural approaches that combined similar technical constraints and architectural ambitions whilst complimenting the properties of Sitka spruce and the available skills and technology:

The General Panel System by Konrad Wachsmann and Walter Gropius, used repetitive and standardised elements to provide flexibility in design;

The Segal Method by Walter Segal used sets of standard length and section timber for the simple, unskilled construction of self-build houses;

The 'Espansiva' system by Jørn Utzon modularised a complete house into post and beam foundations and portal frames, infill floor, wall and roof panels and finishes.

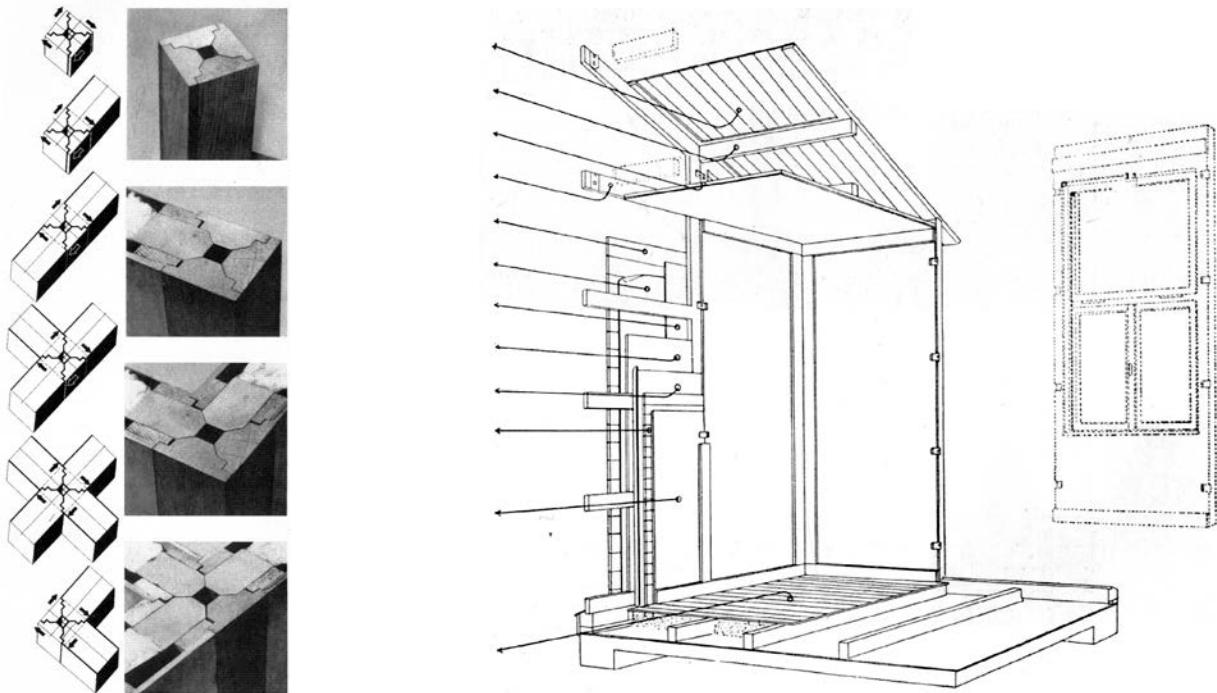

The General Panel System by Konrad Wachsmann and Walter Gropius

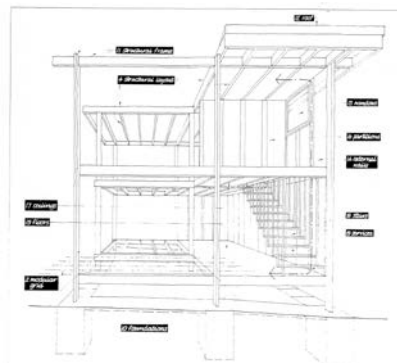
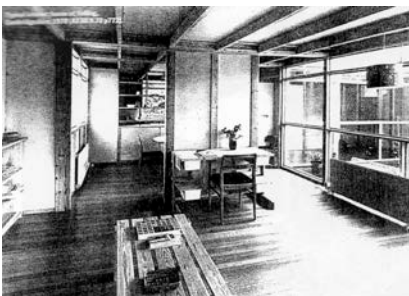

Segal Method by Walter Segal

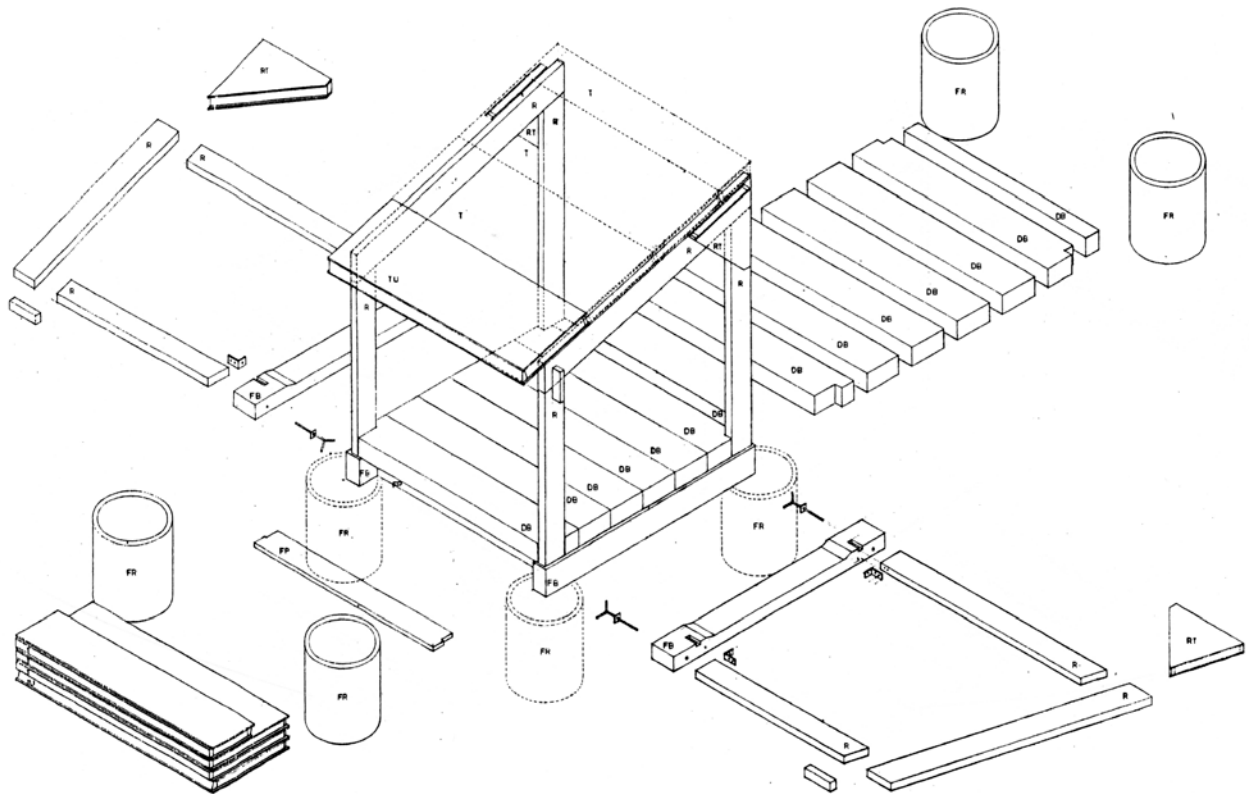

'Espansiva' system by Jørn Utzon

It was the latter of these that proved most influential in the formation of 4 module proportions similar to the framing of traditional Welsh cruck-framed houses. Each corresponded to both the 4 standard sizes of timber available at local sawmills and the functions of a house based on a 600mm grid:

Spatial modules could then be combined in a variety of ways to form different house types while using the same sections of post and beam with standard roof pitches of flat, 17.5, 25 or 35 degrees. DRUw undertook a design workshop using the 'Espansiva' principles with Mogens Prip-Buus, an associate of Utzon's who had worked on the original system.

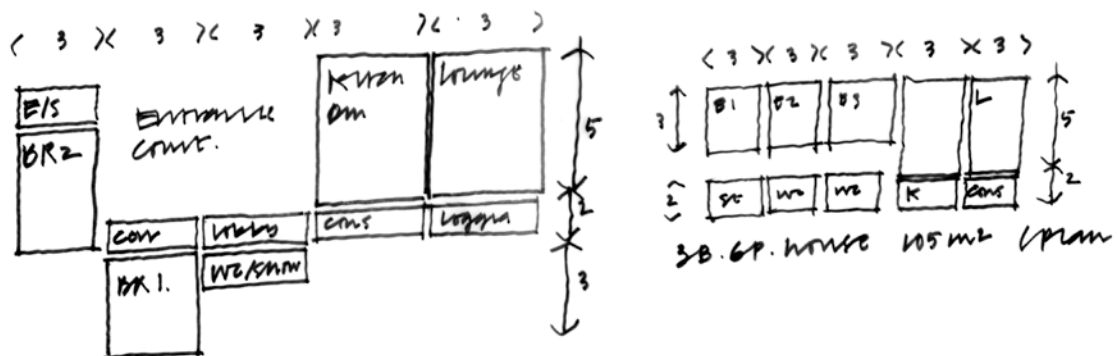

Spatial configuration of rooms based on module sizes

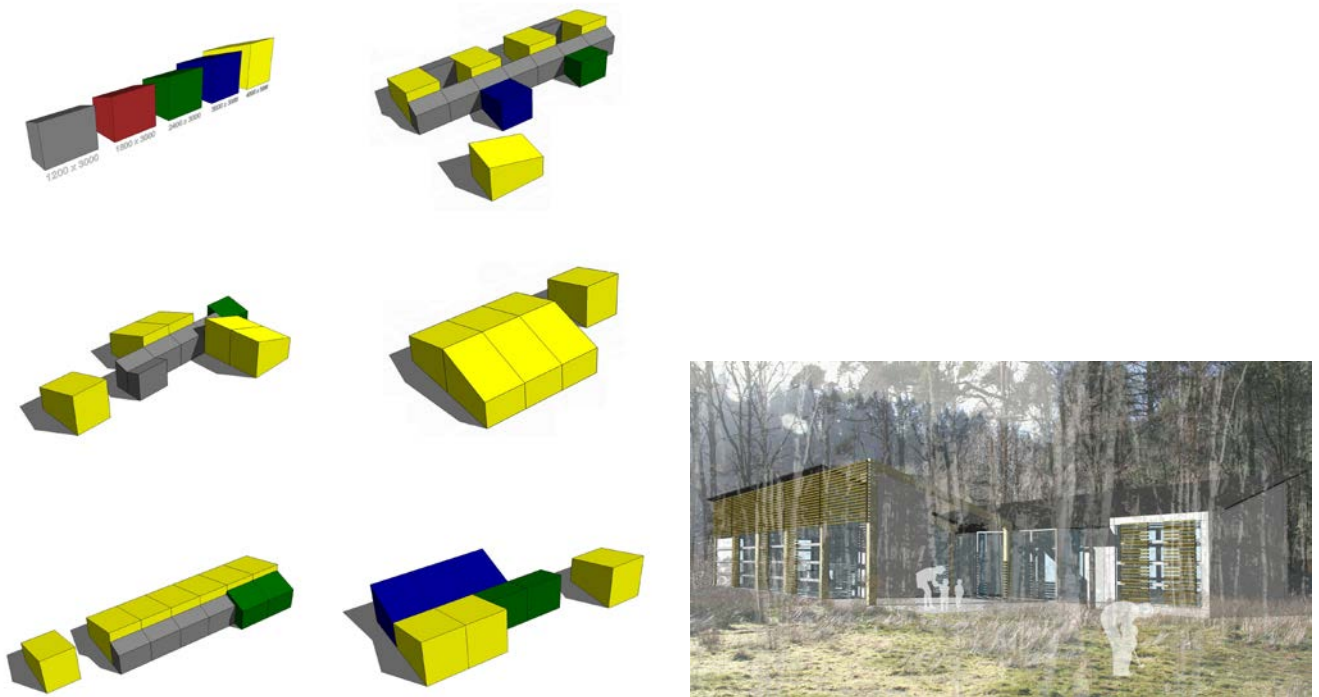

Left: Volumetric module arrangements arranged to form a variety of house types

Right: Concept image of a rural house type, based on early spatial and component studies

1.4 Prototype I: the system

The initial thoughts regarding the timber components were based closely on the precedent studies and therefore to develop:

- repetitive and modular based components;
- a spatially flexible timber post and beam system with infill panels;
- components that were lightweight and simple to construct on-site; and
- provide flexibility in design and future re-use.

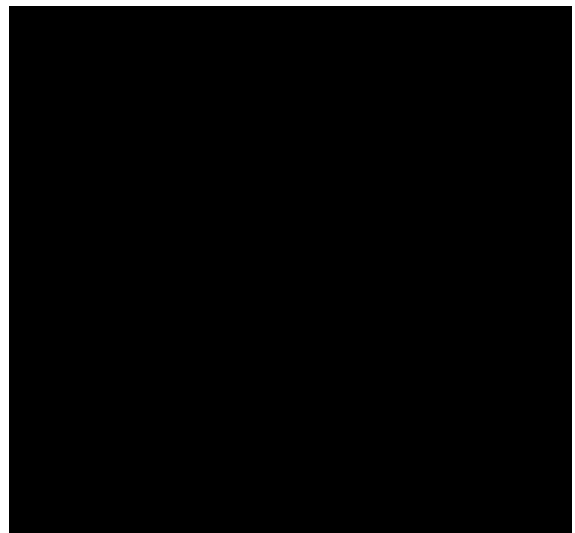
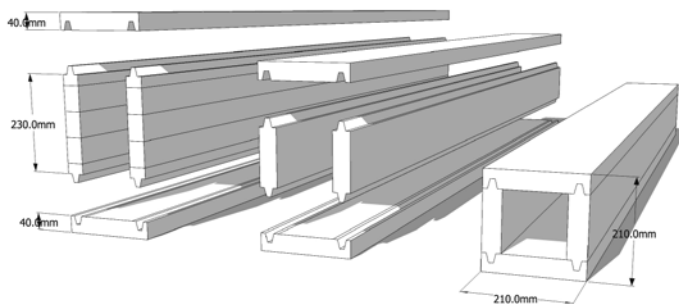

1.4.1 Componentry

The preferred option, influenced by the Espansiva spatial precedent, was to fabricate box section post and beams to generate 'portal' frames. The wall thickness and therefore post size was to be determined more by the required U-values, than by structural loading, and by the qualities of sustainable insulation with 200mm typically giving $0.2W/m^2K$ or better. The box section would use less wood fibre and less labour to fabricate while insulation within the section would reduce the cold bridging effect of solid timber. In the majority of locations a 220mm square box, comprising 2no. 50mm x 225mm (2" x 9"), C16 grade plus 2no. 50mm x 175mm (2" x 7"), was proposed. However, for more highly stressed locations, such as floors and larger spans a 220mm x 280mm box could be used so the whole structural frame could still be built from 50mm x 225mm, ordinary quality spruce.



Box beam fabrication process/ sequence: raw material, assembly and prototype press

The initial press prepared to manufacture these prototype box sections demonstrated how simple the manufacturing process is and how easy it would be for other parties to replicate with very low capitalization.

The press was fabricated using galvanised steel rectangular hollow sections, softwood, a laminate kitchen worktop and expandable firefighter's water hose.

As portal frames, the box section post and beams would provide all the structural rigidity a house requires. This has been achieved through the use of end grain jointing between elements. 6no. M12 or 4no M16 studs are resin bonded into the end grain of a spruce box section. These studs are then passed through an adjoining component and secured with washers and nuts to provide the fixing between all structural elements.



Portal frame and end grain bolts

The infill for walls, floor and roof, embrace much the same philosophy. Cassettes or boxes using the same 50mm x 225mm re-sawn to 25mm boards, for all faces, can be made long enough to span in either direction – influenced by standard sized openings for doors and windows.

While this elemental method was a good starting point using 100% homegrown softwood and created a lightweight and strong structure, both model and 1:1 prototyping revealed

- an increased number of individual components rather than repetitive elements;
- more complex details required to reduce the potential for air leakage and thermal bridging; and
- while the box section infill components were individually structurally good, as a whole they were over engineered and working independently to one-another.

1.4.2 Infill panel development

The system conceived as box section components providing the infill for floor, walls and roof, by simply stacking and spanning between the structural portals, was refined through the development of a larger panel system working on a 600mm component dimension.

A number of systems were considered but the use of a whole Sitka spruce infill panel also has the advantages of a greater flexibility in panel span, and can provide internal finishes if appropriate. Initial research suggests that all three systems would have an insulation zone of between 200 and 250mm and achieve U-values approaching 0.15W/m²K.

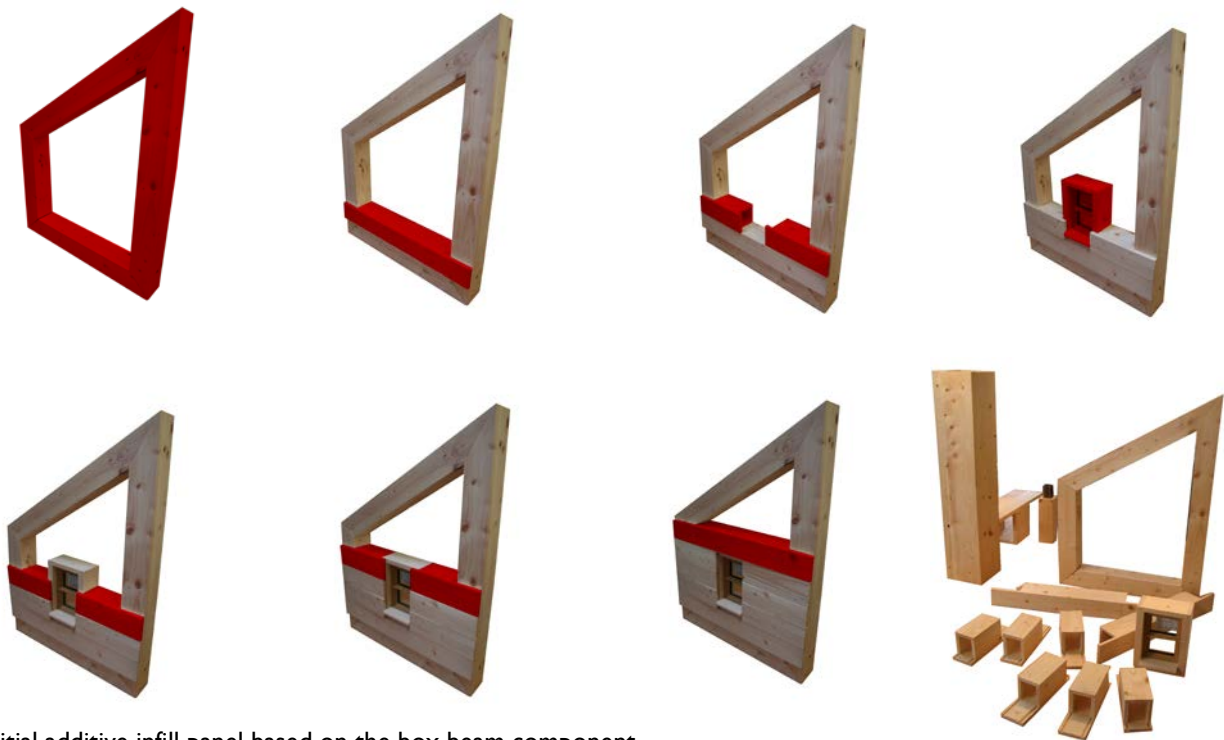

Initial additive infill panel based on the box beam component

1.4.3 Structural engineering

Structural engineering tests based on the architectural principles for the system were conducted initially by Cowley Timberwork Ltd and followed by Burroughs and Glamorgan University to consider the engineering implications of the system including two options for jointing the box beams, one based on internal steel sleeves the other using laminated hardwood cores.

The detailing of the frame was influenced by the following considerations:

Recent Post & Beam projects have shown the practical benefits in detailing of square columns slightly exceeding the wall;
45mm Spruce to C16 grade is readily available up to 220mm wide;
Pad footings (at column bases only) provide quick and easy foundations suitable for challenging rural sites; and
Frame spacing is governed by spatial requirements.



Beam testing at Cowley timberwork.

Cowley Timberwork undertook structural testing on the Ty Unnos box section in early 2008, firstly on a simple beam and then in the form of a portal frame. Tests on the box section beam were very promising with consistently high loadings being met with great efficiency.

1.5 Prototype 2: Smithsonian

1.5.1 Introduction

This exhibition pavilion was designed for the Welsh Assembly to be part of the Welsh representation at the Smithsonian Folklife Festival in Washington DC in 2009. It was designed to exhibit both Ty Unnos through itself and the history of Welsh forestry and management.



Initial plan study for the Smithsonian pavilion based on a 2 bed house-type

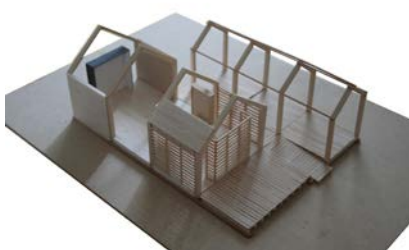
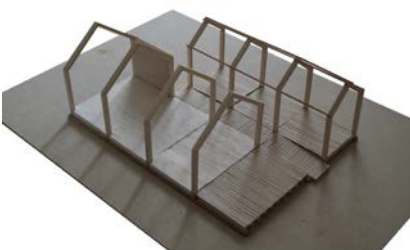

Initial study model for the Smithsonian pavilion, based on the plan above

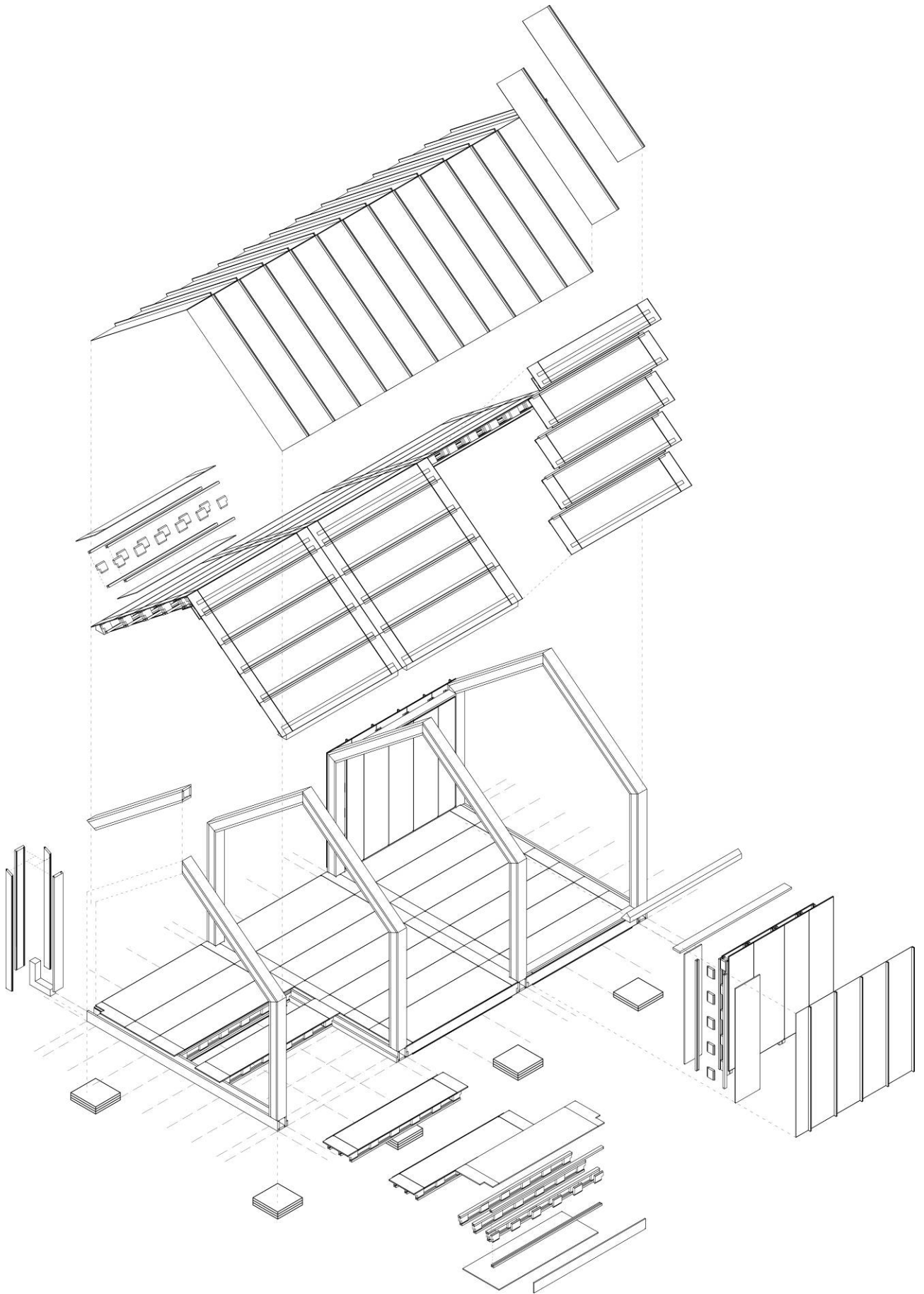

Exploded axonometric of the Smithsonian pavilion, as built

1.5.2 Objectives

This structure was designed specifically around the principles of the early design concepts and house types to test the structural, spatial and material performance of the components in a non-weathertight, un-insulated exhibition pavilion to be fabricated and erected in Chirk, Wales before being dismantled, packed into a shipping container and shipped to Washington DC for re-erection by a team in USA guided by two of the original team.

The principle aims for this structure were primarily focused on the first use of the Ty Unnos system and as such were to:

- test at 1:1 the use of all box section components in a publicly accessible enclosure;
- use Sitka spruce 'ladder' beams with t&g spruce boards as well as some with OSB/3 for infill wall panels;
- test the use and tolerances of internal hardwood junction sleeves for all portal connections; and
- test the construction sequence for ease of construction, component weights and practicality.



Construction sequence and finished pavilion on site in Washington DC

1.5.3 Outcomes

Whilst the principles of the system were proved under 'real' manufacture, transport and erection conditions a number of technical problems were revealed:-

- Successful, first publicly accessible Ty Unnos structure;
- Successful low-tech erection of frame and panels (no crane needed);
- Ladder beam panels appear to work but further testing required;
- OSB panels proved far more reliable than the t&g covered panels;

- the hardwood insert connector tolerances were not accurate enough - the frame settled over time due to timber movement and allowable tolerance. (future connectors like this would be designed with a smaller angle to compensate for and resist the settlement);
- Structure was easily assembled, dismantled, stored and rebuilt etc;
- the spatial module sizes leant themselves well to the application of other material finishes - such as the Urban Colourcoat roof and wall cladding;
- Level threshold detail and ramp access details highlighted as a potential concern for future projects

1.6 Prototype 3: ERC

1.6.1 Introduction

The opportunity to design and build an Environmental Resource Classroom in Ebbw Vale provided the first opportunity to utilise the Ty Unnos components in a fully functioning, weathertight building. The classroom was designed for Blaenau Gwent County Borough Council and Gwent Wildlife Trust and was built between November 2009 and May 2010 as a study into simple, modular construction techniques in a post-industrial landscape.

The 140sqm Environmental Resource Classroom was to be run by Gwent Wildlife Trust, to allow local school children and community explore the heritage and ecology of the former steelworks site. The centre provides: Wildlife courses for people of all ages; Specialist courses for school children linked to the foundation and key stages; A focal point and meeting place for community environmental activities and conservation volunteering. Blaenau Gwent County Borough Council's vision for the project was to:

- Create a high quality educational and cultural facility that celebrates the synergy between heritage, built and natural environments;
- Promote sustainable building and demonstrate renewable energy use; and
- promote the use of the Ty Unnos system in conjunction with other local materials and suppliers.

The classroom is located to respond to the geometry of the former pumphouse and filtration tanks, which have become a haven for wildlife since the closure of the steelworks. The design has been informed by the immediate context of wildlife and materials which informed the following concepts:

Simplicity - A rational, layered building that expresses construction and environmental strategies.

Zoning - exploit two key axes:

Environment - be a didactic demonstration of passive and active design measures such as passive ventilation; air to air heat pumps; solar hot water; solar control; collection of rainwater; and exposed M&E linking all the systems together.

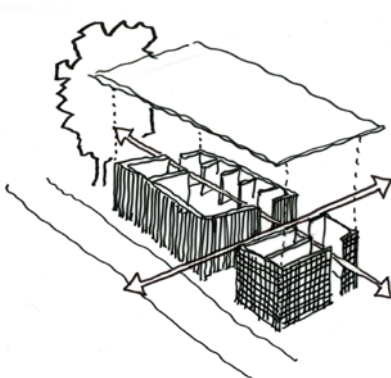

Simplicity

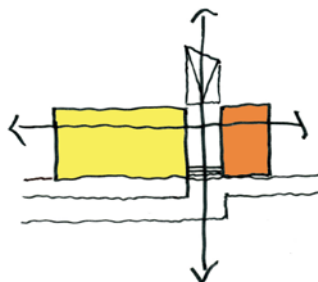

Zoning

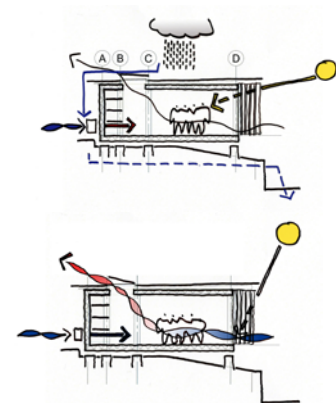

Environment

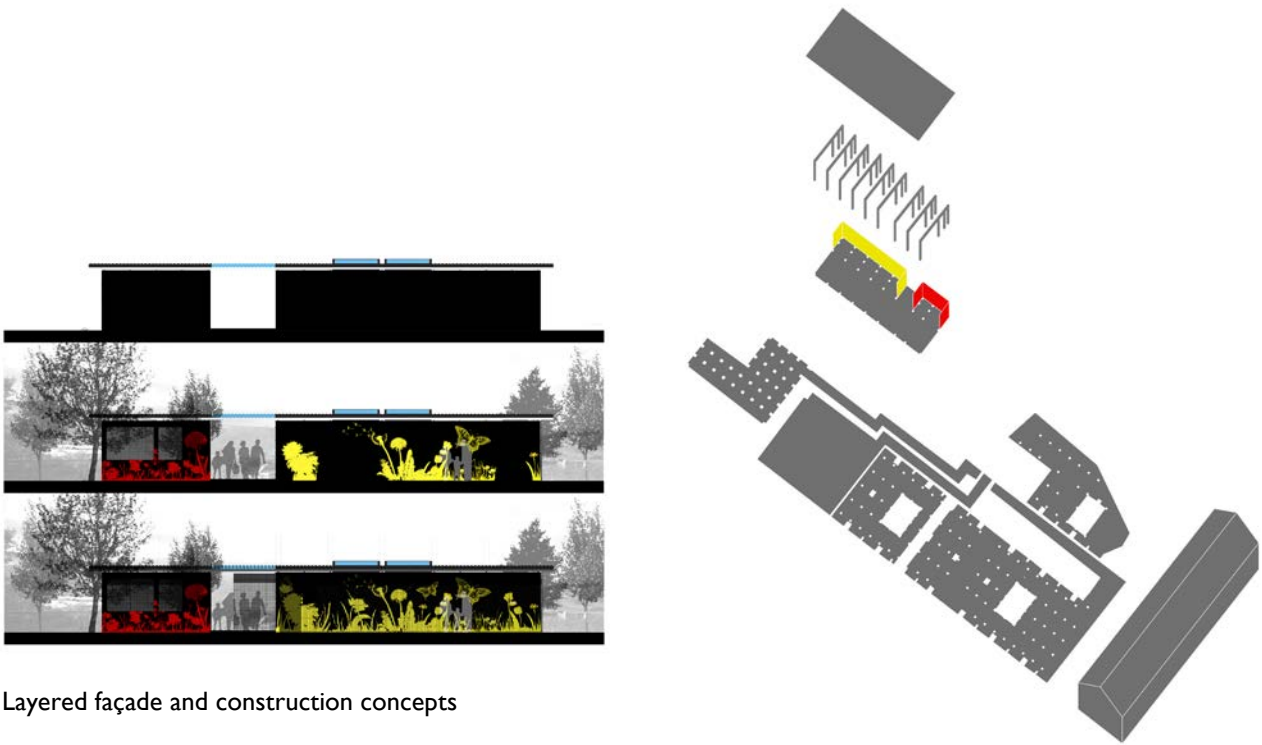

Layered façade and construction concepts



Perspective view across ponds of proposed classroom

1.6.2 Objectives

While not a domestic building the scale of this single classroom project lent itself to the domestic scale components being developed and therefore provided an appropriate prototype for the system. The aims for the development of the Sitka spruce construction system in the design and fabrication of this prototype were:

- to use the standard sized box section components as a simple frame for ground floor, posts and roof with end grain bolting for all frame connections;
 - to use Structurally Insulated Panels (SIPs) as the infill for floor, walls and roof that would provide all the necessary racking resistance for the frame;
 - to expose the timber surfaces as the final internal finish;
 - to use laminated Welsh oak windows as part of the overall modular system; and
 - use charred Welsh low value softwood as an external rainscreen to demonstrate a growing integration of the system componentry.
- To achieve low energy and carbon performance primarily through a 'fabric first approach' to the building system.

1.6.3 General construction

The ERC uses the standard timber sizes available from local sawmills that are fabricated into 270 x 210mm box beams using low tech presses and standard milling machinery. This prototype comprises 9no. 7.2m long portal frames at 2.4m centres with 2.4m x 1.2m birch and spruce plywood Structurally Insulated Panels (SIPs) between for floor, walls, doors and roof. These panels are coated with Envirograf, an intumescent fire retardant, and kept exposed as the internal finish for walls and ceiling.

Prefabricated off-site, the box section and SIPs superstructure was assembled in 10 days by a team of 4 carpenters. To improve efficiency and minimise environmental impact a layered, elemental construction approach was adopted. From inside to out: Ty Unnos frame, plywood SIPs with surface mounted services, EPDM rubber membrane, aluminium composite graphic panels, charred softwood or galvanised steel grating and rainscreen roof. Each component was specified to facilitate easy man-handling on-site and a quick erection programme to minimise any damage to the exposed internal timber surfaces.

The Ty Unnos posts, beams and panels were fabricated by Cowley Timberwork who pre-coded each element prior to delivery to match the construction methodology. The components were delivered to site in reverse construction sequence and stored in the correct order adjacent to the site to minimise travel distance.

- 1- 2100x2100mm Plateau rooflight
- 2- Sinusoidal galvanised steel roof sheeting
- 3- 140mm galvanised steel C section with timber batten insert
- 4- 140mm galvanised steel C section
- 5- Timber deck to create falls
- 6- 270x210mm Sitka Spruce Ty Unnos beam
- 7- 225mm Structurally Insulated Panel with 15mm spruce plywood either side
- 8- 270x210mm Sitka Spruce Ty Unnos post
- 9- Resitrix membrane
- 10- 4mm composite steel sheet with printed murals
- 11- Birch plywood storage unit
- 12- Precast concrete retaining wall unit, screeded to create falls
- 13- 55x55mm Type N Elefant grating
- 14- 225mm Structurally insulated panel with 15mm spruce plywood on either side
- 15- 270x225mm Sitka Spruce Ty Unnos beam
- 16- 254 galvanised UC

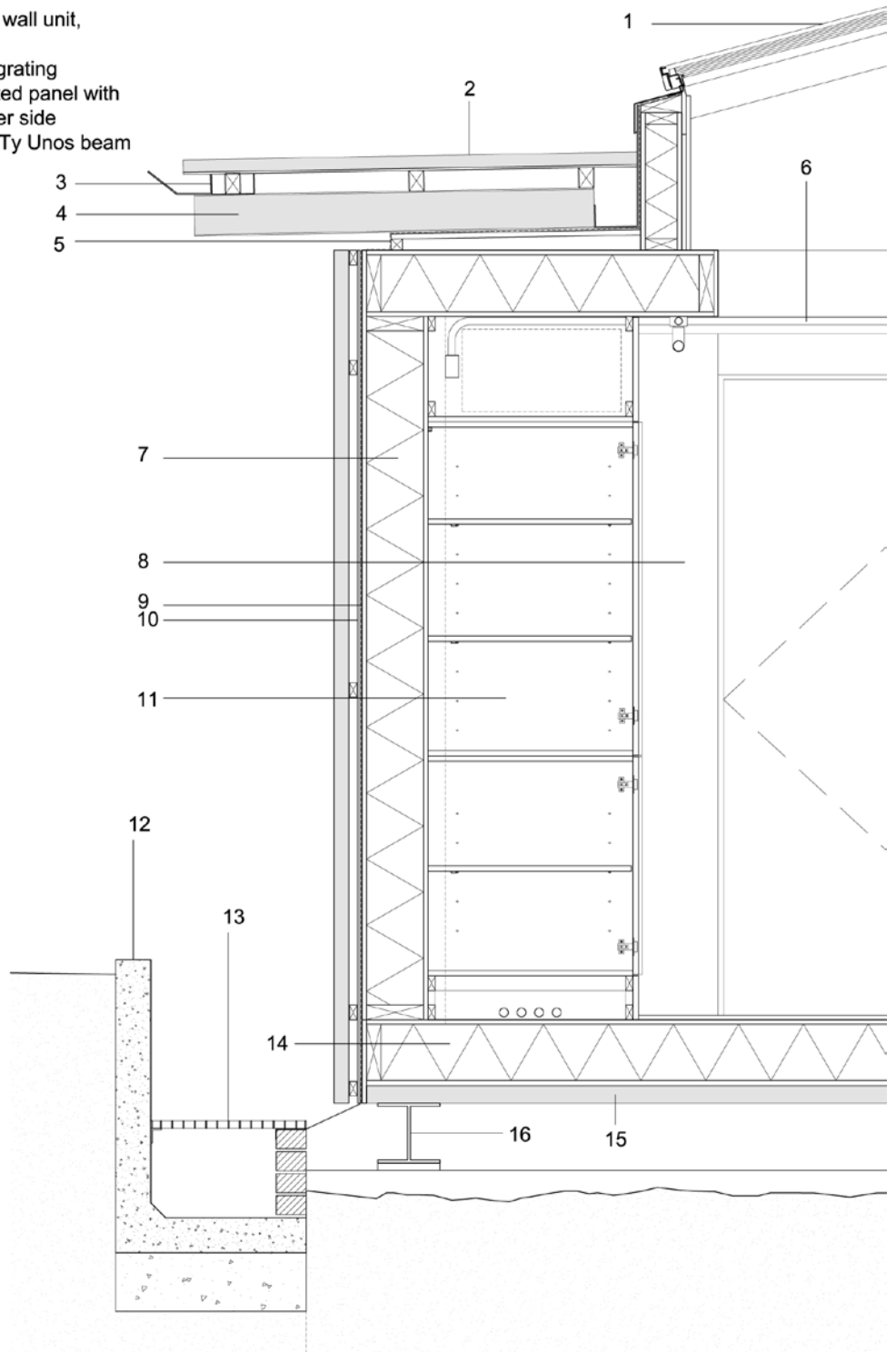

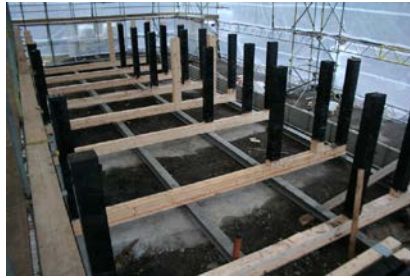

Construction sequence of the ERC, highlighting the layered and additive approach to construction, from site, to off-site fabrication and erection of box section frame and exposed SIPs infill panels for floor, walls and roof.

1.6.4 Outcomes

- The completed system was not manufactured locally;
- The choice of end-grain bolting was successful and aided the simple, no crane, construction process (frames and panels erected in 10 days);
- The manufacturing of the end-grain bolts is not that low-tech - is this repeatable in Wales a less equipped workshops?
- The standard -sizes of box post and beam were used , although Cowleys decided to increase floor and roof beam length to 7.2m for ease of construction and transportation, but the beams were supported at the 4.8m point by foundation and box section post;
- The level threshold detail was dealt with by using the natural fall to the site, but a large cutting was required to allow for underfloor ventilation - this still needs refinement for future projects;
- The principle of a simple layered construction worked very well, but were there too many layers? (graphics added extra requirement)
- Exposing internal finishes creates a difficult time consuming and costly construction process (especially when built in the winter) to avoid weather damage;
- fire protection combined with hard wearing varnish for internal finish worked well;
- While services were exposed in this building, the construction highlighted potential problems with services integration on other types of building;
- SIPs panels were very lightweight and a complimentary Ty Unnos component for floor, walls and roof, but how sustainable - EPS? and where would they be manufactured in Wales?
- oak laminated windows successfully re-implemented previous research into Welsh wood windows using small sections and lengths of local hardwoods. (Coed Cymru and Coed Derwen)
- charred timber used very low quality softwood. the building has been up for 3 years now and the cladding is still protected by its charred finish. How long will this last? how would this be specified and produced on future projects? can it easily be replaced if or when it does fail?

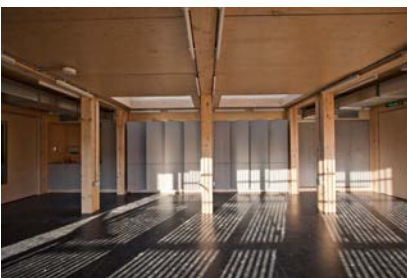

Completed ERC

1.7 Prototype 4: Ty Unnos longhouse

1.7.1 Introduction

Following funding won through a Technology Strategy Board (TSB) competition for the low impact building systems launched in 2009 a fully developed and regulatory compliant 2 bedroom house was designed and built as the focal point for testing the complete integrated system using a local supply chain. The building was opened by the Welsh Minister for the Environment in August 2010.

The commission was won through an open design competition conducted by the Welsh Future Homes project partners.

The Welsh Future Homes project is a unique development of three affordable and highly sustainable houses and a visitor centre located on the site of the old steel works at Ebbw Vale, Wales. The development is the result of a partnership between BRE Wales, the Welsh Assembly Government, Blaenau Gwent Council and United Welsh Housing Association. The overall aim of the project has been to stimulate the development a low carbon built environment in Wales but also to kick-start a 'green' economy in the country.

The 'mini community' comprised of three other sustainable homes. All of the houses have cost between £1,200 – £1,600 m² to build (average cost of social housing Code 3 is £1,200m²). Funding for the project came from the Heads of the Valleys Programme and Blaenau Gwent Council.



Original competition design for a 3bed 5person house type

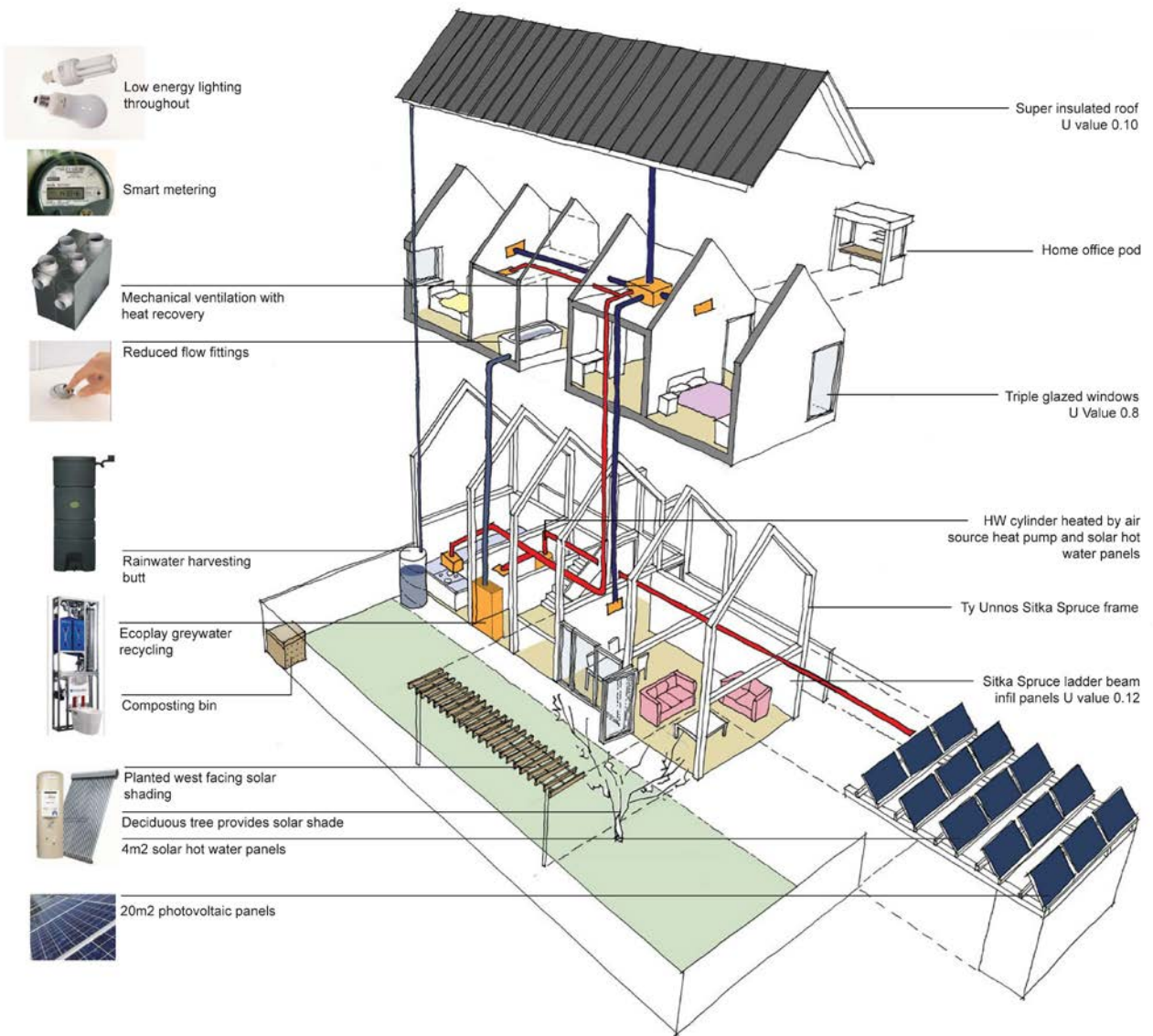

Environmental performance diagram for the initial competition entry



Model of the 2 bed 4 person house type as re-designed and built

1.7.2 Objectives

This was the third and final prototype to test the now refined Sitka spruce components. The primary focus was on the construction of an affordable dwelling using a completely integrated system entirely from the local supply chain :

- An affordable house meeting Welsh Government Design Quality standards
 - a raft foundation and minimum 150mm requirement of timber structure above ground level;
 - a 2-storey structure with loft;
 - infill panels with ground to roof OSB racking resistance;
 - softwood and steel inner connecting sleeves with steel brackets and plates;
 - Welsh chestnut low energy windows; and
 - green Welsh chestnut cladding.
- Longhouse principles of form and space



Construction detail photographs highlighting raised ground floor slab, post and beam connectors and the layered envelope to improve thermal performance

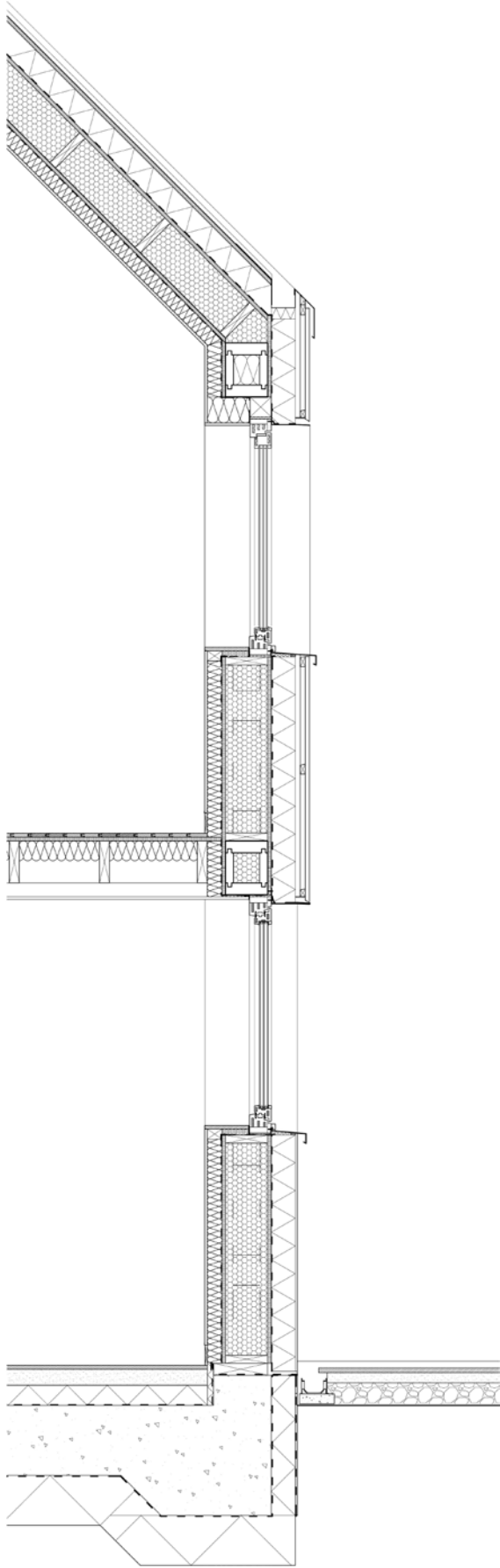

Complete external wall section

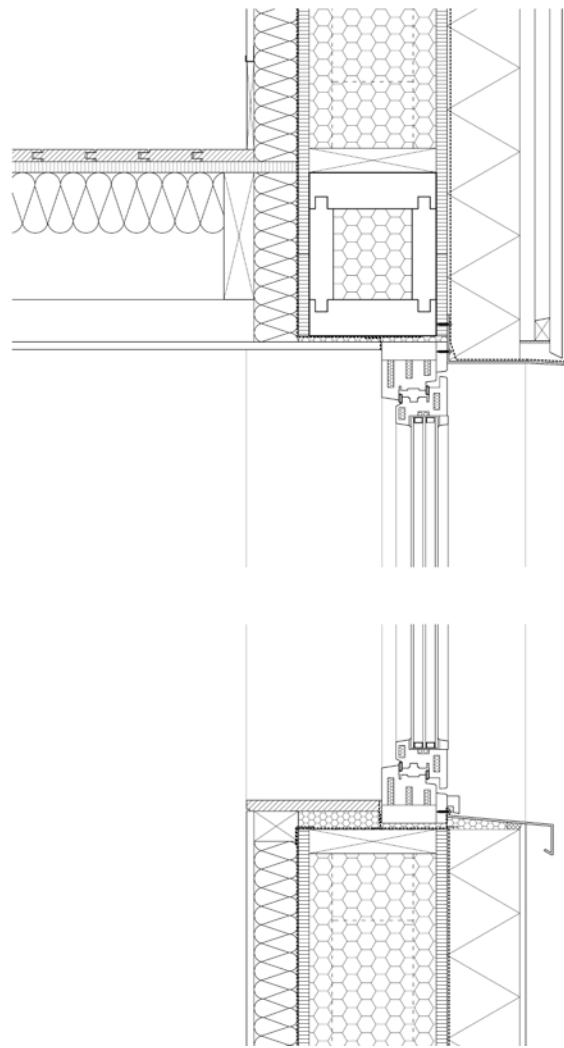

Section through wall to minimise air leakage and thermal bridging

1.7.3 Outcomes

Results show that local, under utilised, low value Sitka spruce can be used in the design of contemporary and sustainable domestic scale architecture in Wales. Through re-engineering the timber, a series of modular responses have been made that shows potential to use homegrown Sitka spruce and other softwoods, as an alternative to importing Scandinavian or North American timbers.

More specifically in the design of small span and domestic scale buildings.

However, some limitations need to be overcome to reduce cost, improve tolerances and flexibility and refine details.

- a modular glue-laminated post and beam structure, maximising the use of readily available, standard lengths and sections of Sitka spruce;
- a modular panel system based on spruce or other softwoods that can provide flexibility in use and adaptation in the future through wall, window and door positions;
- without the need to defect cut any spruce for laminating;
- using basic mechanical fixings such as brackets, plates and screws, to maximise the potential to disassemble the structure later.
- Sustainable (social, economic and environmental)



Completed Ty Unnos longhouse

- First 2-storey Ty Unnos structure - successful;
- built on a raft rather than pad or strip foundations - worked well, but excessive amount of concrete and slightly awkward kerb details to create 150mm Building Regs requirement;
- frame erected in 2 days, complete structure with infill panels erected in a week;
- prefabrication of roof beams already as a 'truss' greatly helped construction;
- softwood and steel insert connectors developed from hardwood connectors on Smithsonian worked well seemingly with very little settlement, but not good with thermal bridging or filling box beams with insulation at each junction;
- low energy aspects pushed the system to its limits;
- thermal bridging not very good due to repetitive box section posts and beams;
- Is the frame needed? a lot of components and timber required for little gain - the infill solid stud and OSB panels were effectively closed panels - just use these?

- The beams between frames between each room prohibited services running with in the floor zones across the house
- The OSB bracing from ground floor to eaves requirements were time consuming and prohibited service penetrations;
- the 70mm difference between box section size and infill panel lent itself well to creating a service void that avoided punching through the air tightness membrane - but only per room, path blocked at each post or beam location;
- Develop the ladder beam further to replace solid stud and reduce weight and thermal bridging effect;

Significant Appendices

Appendix I

Forster, Wayne, and others, 'Ty Unnos (House in a night): An affordable rural housing system using homegrown sitka spruce', *PLEA 2008 – 25th Conference on Passive and Low Energy Architecture, Dublin, 22nd to 24th October 2008*

Forster, Wayne, and others, 'Sustainable Sitka Spruce Housing: Ty Unnos', *NOCMAT 2009, Non conventional Materials and Technologies, BRE Centre for Innovative Construction Materials, University of Bath*

Appendix II

Birch, Amanda. 'Environmental Resource Centre', *Building Design*, 9th July 2010, pp.16-17;

'Wood Champions: The Innovators', *Chartered Forester*, Autumn 2008

Technology Strategy Board, TSB Case Study: Ty Unnos longhouse
<http://www.innovateuk.org/content/case-study/home-grown-welsh-eco-house.ashx>

Design Commission for Wales Case Study: Environmental Research Centre
http://dcfw.org/casestudies/view/environmental_resource_centre/