



I S A V

**Journal of Theoretical and Applied
Vibration and Acoustics**

journal homepage: <http://tava.isav.ir>



Study on transferred impulse and response of steel plate walls under various impulsive loading considering mesh size effects

Seyed Mehdi Zahrai^{a*}, Saeid Lotfi^b

^a Professor School of Civil Engineering, University of Tehran, Tehran, Iran

^b Research Assistant School of Civil Engineering, University of Tehran, Tehran, Iran

ARTICLE INFO

Article history:

Received 23 January 2018

Received in revised form
5 May 2018

Accepted 26 June 2018

Available online 30 June 2018

Keywords:

Impulsive loading

Mesh sizes

Maximum displacement

Steel plate wall (SPW)

Transferred impulse

Energy dissipation

Von Mises stress

ABSTRACT

The behavior of steel plate walls (SPWs) under various impulsive loadings and the effects of different mesh sizes are investigated in this paper. With the aim of accurately inspecting SPWs, a series of analyses with 250 models with different plate geometric assumptions and different blast impulsive loadings are performed to study the SPWs' out-of-plane behavior. The mild steel material specifications are adopted for SPWs with different thickness and stiffener arrangement and ABAQUS software is utilized for the Finite Element analysis. Results of transferred impulse, maximum displacement and Von Mises stress of SPWs show that SPWs with thickness of 5 mm are the best choice against various impulsive loadings in comparison with SPWs with thickness of 20 mm. In fact, the SPWs having the thickness of 5 mm show better performance as a result of more energy dissipation against various impulsive loadings. Finally, the Von Mises stress contours investigated for some models show 28% more stress in P5 SPW than that in P20 SPW. Also, it can be concluded that various sizes of mesh have no remarkable effect on unstiffened SPW while effect of different mesh sizes is more significant with increasing the number of stiffeners.

© 2018 Iranian Society of Acoustics and Vibration, All rights reserved.

1. Introduction

Since blast is able to cause structural failure, taking walls as the elements exposed to blast loads into account is the best way of dissipating the effects of blast impulsive loading. The amount of the transferred impulse to the main structure is among the key parameters in investigating ductile

* Corresponding author:

E-mail address: mzahrai@ut.ac.ir (S.M. Zahrai)

behavior and energy dissipation of steel walls. The transferred impulse can be related to the maximum displacements imposed to the SPWs.

The ductility and blast loading have been studied in various systems. The effect of different arrangements and the rigidity of stiffeners on energy absorption and the buckling modes of steel plate were first inspected by Takahashi et al.[1] in an analytical-experimental study. Simulating large vehicle bombs, Salim et al. studied the performance of blast-retrofit wall systems under static and dynamic field tests. Having presented the analytical modelling and experimental evaluation of steel-stud wall systems under blast loads, they introduced steel-stud walls with proper anchoring as an effective solution for construction of blast resistant walls in either new or retrofit construction. They furthermore proved that the steel studs' ductility and strength alone contribute to resisting the blast load and absorbing the energy from the explosion [2]. In addition, the steel stiffened plates' nonlinear dynamic response was investigated under blast loadings by Tavakoli and Kiakojouri. They stated that adding more stiffeners greatly reduces the plastic deformation energy[3].

Linzell et al. analyzed the steel beam to column joints behavior through the analysis of limited elements against the blast loading and concluded that the strengthened joint enjoys a lower degree of displacement as well as stress and is more appropriate against blast in comparison with not strengthened joints[4]. Hrynyk and Myers examined the URM arching walls out-of-plane behavior with modern blast retrofits. The walls were tested in the laboratory under static conditions and evaluated through several criteria: energy absorption, out-of-plane load resistance, out-of-plane deformability, and the reduction of masonry debris scatter upon collapse. They noted that the retrofit systems decreased or curbed the masonry debris scatter upon collapse[5].

Azevedo et al. investigated the behavior of plates under various impulsive loading. They checked the precision of action after replacing the rectangle-like impact with real blast loading. Furthermore, after they had studied different forms of impact loading, they came to conclusion that the response of structure influenced by these impacts is equal under special circumstance[6]. Snyman investigated the geometrically similar scaling of steel plates under different blast loading experiments. The estimated deflection of the mid-point of the plate was utilized to be compared to the geometrical scale factor which indicated the material properties importance while trying to illustrate "similarity" in the mid-point deflection [7]. Overall performance of a steel plate shear wall subjected to in-plane and out-of-plane blast load was also studied by Moghimi and Driver via numerical methods. The blast loads consisted of shock waves which had appropriate duration for designing petrochemical facilities. The blast resistance was assessed with regard to not only the aggregate absorbed strain energy but also maximum structural displacement[8].

After conducting experiments on steel shear wall system, Moghimi and Driver concluded that wall system is able to highly dissipate energy. Also, steel structures are more flexible compared to concrete structures and more efficient[9]. Al-Thairy examined the reformed approach for the one degree of freedom analysis of steel plates under blast loading[10].

Following the experimental research on stiffened steel plates under blast loading, Zheng et al. stated that the final deformation of stiffened steel plates is more sensitive to thickness of plate than size of stiffeners attached to the plate[11]. Zhang et al. investigated the dynamic response of foam-filled corrugated core sandwich panels exposed to air blast loading. They stated that

compared to the unfilled panels, the panels with back side filling strategy did not show better blast performance. The panels which had front side filling and fully filling strategies appeared to possess desirable blast resistance satisfactorily to block severe fracture under high intensity blast loading. As a result of a comparison between the empty panel and the foam-filled panel with nearly same areal density, it was shown that allocating part mass of front face sheet to foam fillers decreased the front face deflection by 16.5% [12]. Nguyen and Tran explored the dynamic response of vertical wall structures under blast loading and stated that the amount and distance of explosive material had some influence on their dynamic response [13].

ASCE (2011) has a thorough review on the features of metal panel walls for the design of blast resistant buildings and investigates the resistance and ductility of metal panel walls with different thickness as well as configurations qualitatively [14]. According to ASCE (2011) design recommendations, it is possible that the triangular equivalent blast loading be applied instead of reflected overpressure time-history. Hence, in the present study, twenty-five different types of equivalent blast loading are considered.

In this paper, the amount of transferred impulse from different SPWs to main structure and maximum displacements as well as Von Mises stress of SPWs under various blast impulsive loadings are investigated through both material and geometric nonlinearities. In addition, the relationship between maximum displacement and transferred impulse is discussed. In order to investigate the ductility of SPWs, the contours of Von Mises stress, the amount of output impulse and maximum displacement of SPWs are studied considering the effects of various mesh sizes. To achieve extensive results, this research has investigated 250 various models.

2. Parameters of impulsive loading

During a blast, energy is released violently, producing a high-intensity shock front. The shock front expands outward from the explosion surface. A highly impulsive loading consists of a relatively high pressure applied quickly, while a static loading consists of a pressure slowly rising to its peak value over a long period of time [14]. Impulsive loading following a blast is generally prescribed by two parameters of reflected pressure P_r and time duration of loading t_d . The amounts of these parameters depend on the weight and distance of explosion from the structure. In this research, 25 types of triangular impulsive loadings are considered in the analysis investigating the different models of SPWs. The first loading is considered with the peak of 75 kPa and the duration of 10, 20, 30, 40 and 50 msec, the second loading peaks at 150 kPa with the same durations and other loadings have the peak of 225, 300 and 375 kPa with the same durations.

3. Model of steel plate wall

As depicted in the Fig. 1, the SPW with out-of-plane behavior is the first structural element to which the blast impulsive loading is applied. This SPW which has various stiffener arrangement as well as plate thickness is studied under blast impulsive loading. In case of a SPW connection to the structural columns, a large portion of blast loading transmits to the columns and columns are lost due to reduction of buckling resistant. Consequently, progressive collapse may occur. Therefore, it is suggested that only two horizontal edges in top and bottom of the SPW be connected to adjacent structural elements.

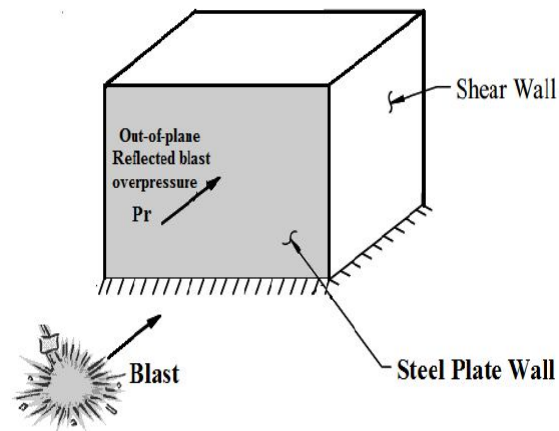

Fig. 1. SPW utilized in present study.

4. Material and geometry of models

In this research, ABAQUS is used for finite element analysis of steel plates. The Cowper-Symond is utilized for considering strain rate dependency[15]. The damping effect has been considered via Rayleigh damping coefficients in all types[16]. In this study, ST37 steel with modulus of elasticity of 210 GPa, density of 7800 kg/m³ and Poisson's ratio of 0.3 is applied. The yield and ultimate stresses of steel are 240 and 370 MPa, respectively. In order to achieve a suitable design, the analysis of plates is conducted with regard to various stiffener arrangements and plate thicknesses. Dynamic response of SPW depends on the plate width and thickness. The geometries of models having different stiffener arrangements are depicted in Fig. 2 with related meshing in these models. The sizes of mesh elements were considered 0.03, 0.06 and 0.12 m in this study. All dimensions of plates are three by three and the distance of stiffeners and their edges is equal.

Regarding the labelling of models shown in Fig. 2, the thickness of steel plates and stiffeners is equal in all models which means if the thickness of plate is 5 or 10 mm, the thickness of stiffeners will be 5 or 10 mm. In this labelling, the number coming after letter P indicates the thickness of plates and stiffeners in mm. If the model has a stiffener, letter S is used and the number of stiffeners is equal to the number that follows letter S. The number mentioned after stiffener represents the height of stiffeners in mm. For example, the plate of P5 S5 100 is a kind of plate whose plate and stiffener thickness is 5 mm with 5 stiffeners which are 100 mm high. The shell element in ABAQUS software was used to model the SPWs. Additionally, the explicit analysis is used for the nonlinear dynamic analysis.

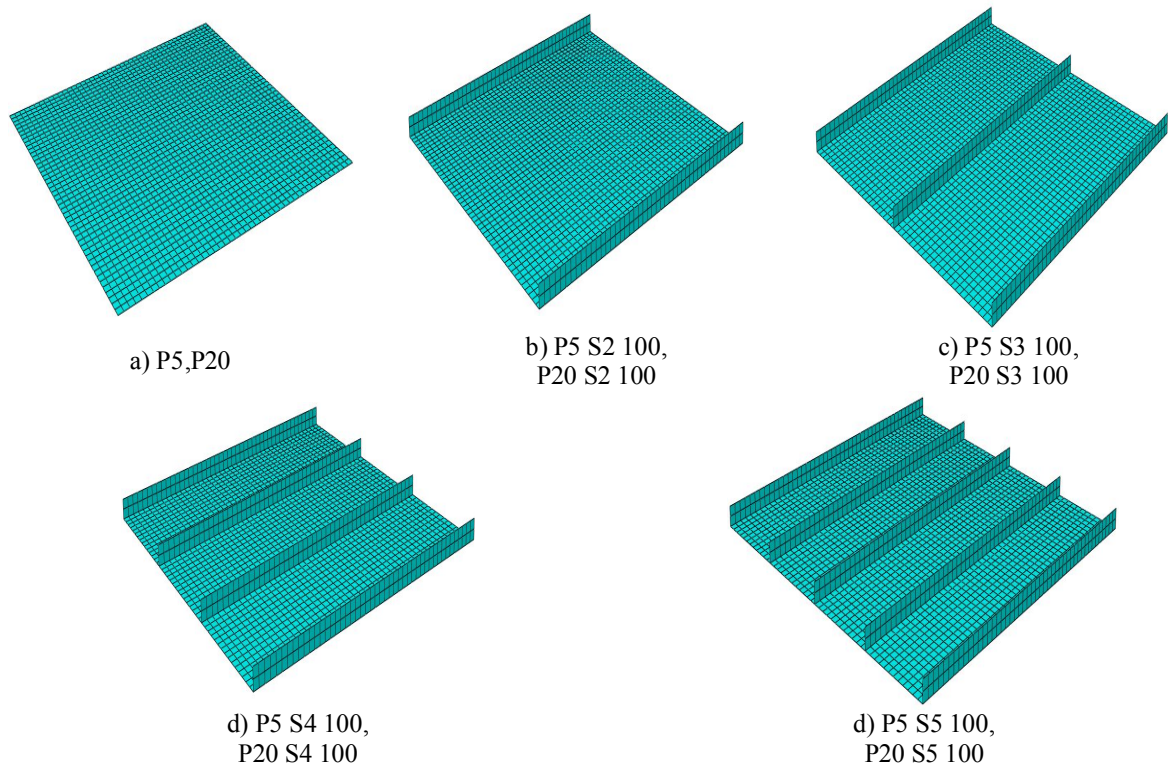

Fig. 2. Stiffener arrangements of SPWs with structured mesh.

5. Verification

In order to verify the numerical models in this paper, some analyses of V shaped plates under blast loads are taken into account. Markose and Rao[17] investigated the effectiveness of different V-shaped plates for finding its response under different plate angles, mass and eccentricity of the TNT charge. Fig. 3 shows the V-shaped plate they used for simulation. It was stated that the two edges of the plate were fixed to the vehicle. The solid elements in ABAQUS were also used to simulate the plates against blast loading. The material examined for the V-plate was mild steel with plate thickness of 16.66 mm, $E=203$ GPa, $\nu=0.3$ and $\rho=7850$ kg/m³. The Johnson Cook (JC) damage model (Johnson and Cook 1983) was used for the simulations employing high strain rate. A total of two explosive charges 14 and 17 kg were detonated at 0.41 m standoff distance directly under the hull.

The results of this study as well as Markose and Rao's[17] are compared in Fig. 4. This figure depicts the surface deflection of 145° plate for increasing the explosive mass.

As observed in Fig. 4, there is a fairly appropriate correlation between results of this study and those by Markose and Rao[17].

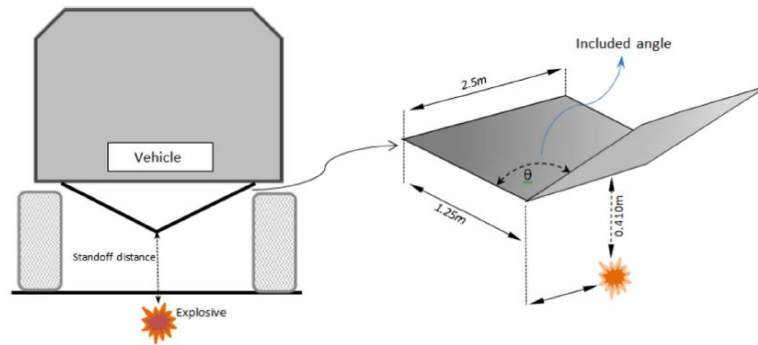

Fig 3. The V-shaped plate [17]

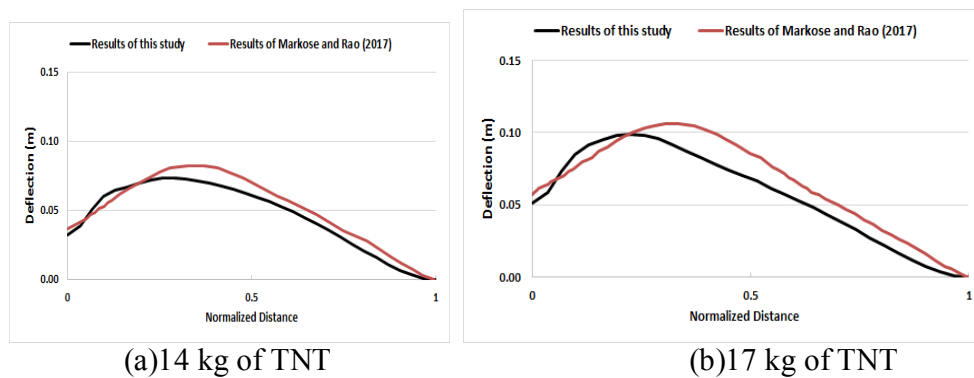

Fig 4. Deflections of 145° plate in this study compared to those of Markose and Rao[17].

6. Steel plate wall (SPW) loading

As shown in Fig. 5, in order to simplify the blast resistant design procedure, the generalized blast wave profiles are usually linearized. Fig. 5 represents a typical shock load and its linearized triangular step-type load. P_r is the reflected blast overpressure and t_d is the positive-phase duration, or the duration of the linearized triangular step-type load. A number of impulsive loadings with reflected blast overpressures of 75, 150, 225 and 300 and 375 kPa and durations of 10, 20, 30, 40, and 50 msec for all plates are utilized as illustrated in Fig 5. In fact, the time durations of 10, 20, 30, 40 and 50 msec are considered for every reflected pressure.

It is noteworthy that with regard to all SPWs shown in Fig. 2 and twenty-five different blast impulsive loadings applied to all plates, 250 different models have been utilized in this paper in order to study the precise behavior of SPWs against the various blast impulsive loadings.

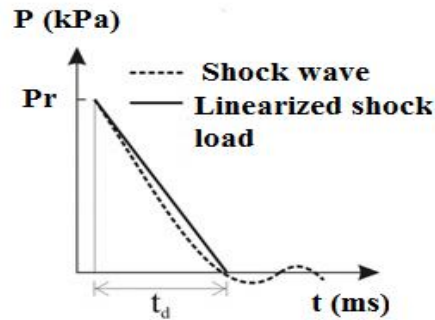

Fig 5. Blast impulsive loading considered in this study [4].

7. Amount of transferred impulse to main structure

In this section, the amounts of transferred impulse from SPW to main structure are stated. Figs. 6 to 10 show the transferred impulse from SPW to main structure. In these figures, output impulse is the transferred impulse from SPW to the main structure. In these graphs, output impulses of SPWs under blast loads are studied. It is clear in all loadings of 75, 150, 225, 300 and 375 kPa in Fig. 6 that the more duration of blast continues, the more output impulse of steel plates increases. It is obvious in Fig. 6 that with increasing the reflected pressure of blast loading and the duration of blast loading, output impulse of P5 and P20 increases. In this figure, it is observed that the largest output impulse in P5 and P20 steel plates is related to the loading with reflected pressure of 375 kPa and 50 msec duration and the lowest output impulse is related to blast loading with the reflected pressure of 75 kPa and 10 msec duration.

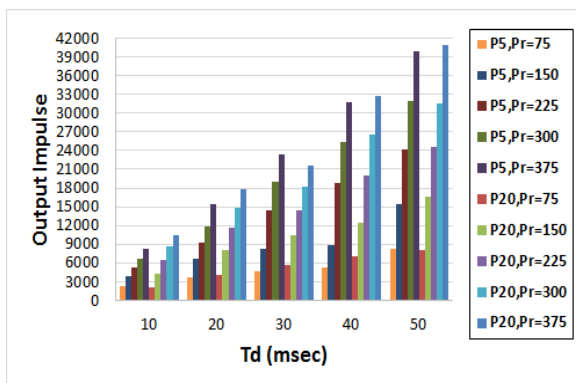

Fig. 6. Output impulse of P5 and P20 SPWs under various blast loads.

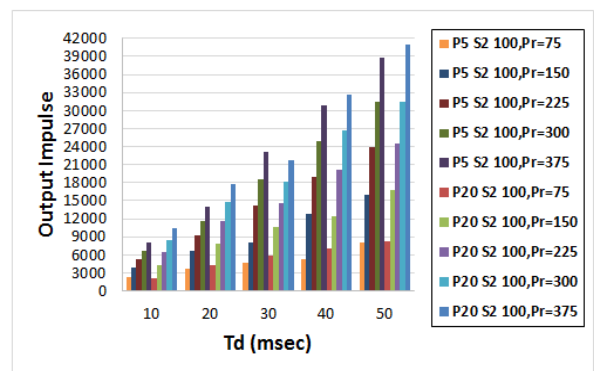

Fig. 7. Output impulse of P5 S2 100 and P20 S2 100 SPWs under various blast loads.

It is obvious that the increase in thickness of SPWs from 5 to 20 mm leads to more increase in output impulse in many graphs. According to Fig. 6, in general, the more the thickness of SPWs increases the more impulse transfers to main structure so the P5 SPW is better than P20 due to inducing less output impulse. This increase can be related to ductility of SPWs. With increasing

the thickness of steel plate, this plate will be more rigid leading to ductility decrease. With decreasing ductility, the amount of dissipated energy will be decreased. So, more impulse will be transferred to main structure in the 20 mm steel plate.

Similar to Fig. 6, Fig. 7 shows that the increase in duration of blast loading in all 75, 150, 225, 300 and 375 kPa increases output impulse of SPWs. Also, it is clear that with increasing the reflected pressure, output impulse of all SPWs increases. Also, increasing the thickness of steel plates from 5 to 20 mm causes an increase in output impulse in models.

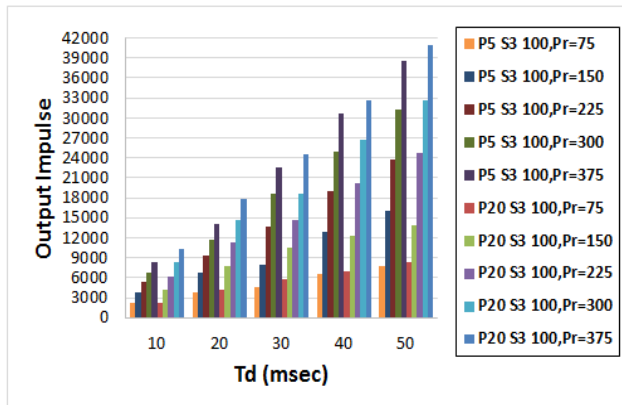

Fig. 8. Output impulse of P5 S3 100 and P20 S3 100 SPWs under various blast loads.

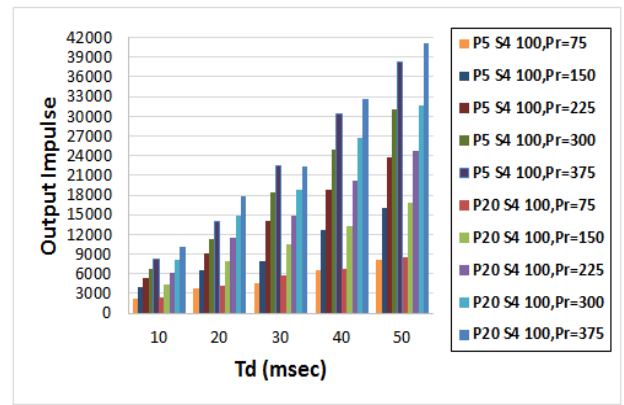

Fig. 9. Output impulse of P5 S4 100 and P20 S4 100 SPWs under various blast loads.

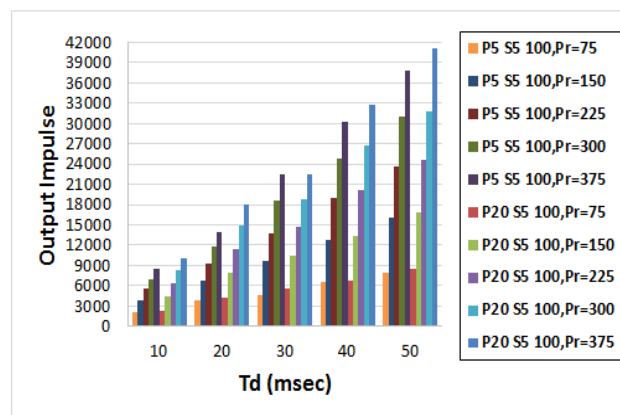

Fig. 10. Output impulse of P5 S5 100 and P20 S5 100 SPWs under various blast loads.

According to what mentioned about Figs. 6 and 7, the more the reflected pressure and time duration increase the more impulse transfers from SPW to the main structure. This process is true for Figs. 8 to 10. Figs. 8, 9 and 10 are related to steel walls of P5 S3 100, P5 S4 100 and P5 S5 100 respectively. Figs. 6 to 8 show that increasing the time duration or reflected pressure of steel walls causes increase in the output impulse. Also with increasing the thickness of plate from 5 to 20 mm, the output impulse increases. In fact the time duration and reflected pressure have significant effect on transferred impulse to main structure. Increasing the thickness of SPWs from 5 to 20 mm in many models causes increase in output impulse. In fact, the SPWs with

thickness of 5 mm has better performance due to more decrease in transferred impulse against blast impulsive loading. As it is clear in Figs. 6 to 10, the number of stiffeners has less effect on reduction of transmitted impulse to main structure. In general, investigation of the Figs. 6 to 10 show that 5 mm SPWs dissipate more impulse compared to 20 mm SPWs.

8. Maximum displacement of various steel plate walls

In this section, maximum displacements of P5, P20, P5 S5 100 and P20 S5 100 SPWs are studied in details under blast impulsive loadings. The curves of maximum displacement of the SPWs are taken from contours of deformation using ABAQUS program. Figs. 11 and 12 show the location of maximum displacement in the P5 and P5 S5 100 steel walls with reflected pressure of 375 kPa and time duration of 50 msec. As it is obvious from these figures, the maximum deformation takes place in the middle of vertical edges of steel plates. Also, it is clear that adding stiffener can control deformations in critical area of panel surface.

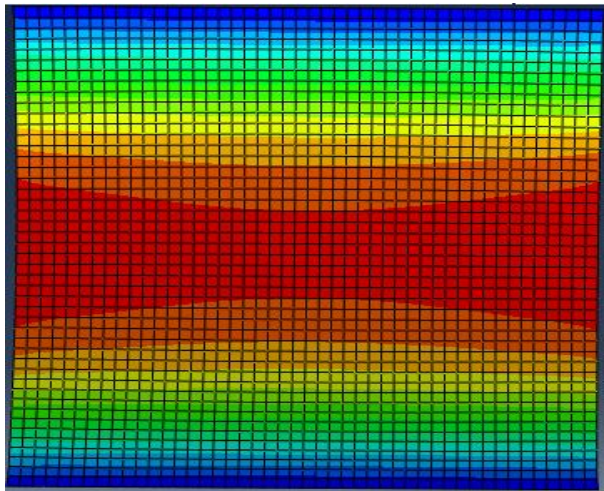

Fig. 11. The location of maximum displacement in P5 SPW with reflected pressure of 375 kPa and time duration of 50 msec.

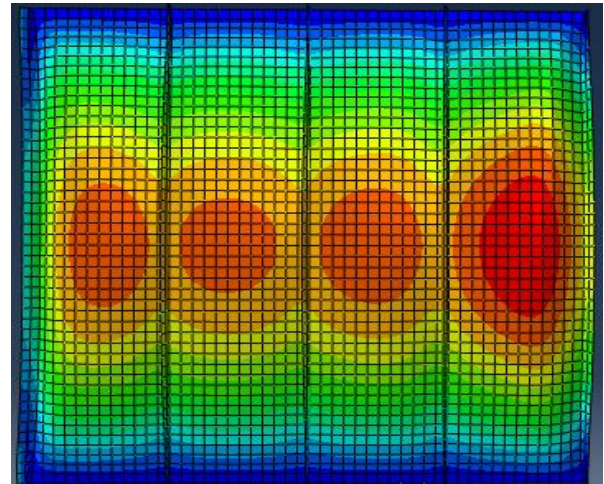

Fig. 12. The location of maximum displacement in P5 S5 100 SPW with reflected pressure of 375 kPa and time duration of 50 msec.

In the following, graphs of maximum displacement of SPWs under various blast loads are studied. It is clear in Fig. 13 that in all reflected pressures, the more duration of blast continues, the more maximum displacement of P5 plate increases. The maximum displacement of SPWs with the increase in the blast duration can be observed in all loadings of 75, 150, 225, 300 and 375 kPa. The most maximum displacement of P5 infill panel is related to blast loading with the reflected pressure of 375 kPa in 50 msec duration and the minimum one is related to blast loading with the reflected pressure of 75 kPa in 10 msec duration.

As shown in Fig. 13, with increasing the duration of blast loading and the reflected pressure of blast loading, maximum displacement of P20 SPW increases. Like the curves of P5 SPWs, it is observed in Fig. 13 that maximum displacement of P20 SPWs related to loading with reflected pressure of 375 kPa and 50 msec duration and the minimum displacement is related to blast loading with the reflected pressure of 75 kPa in 10 msec duration.

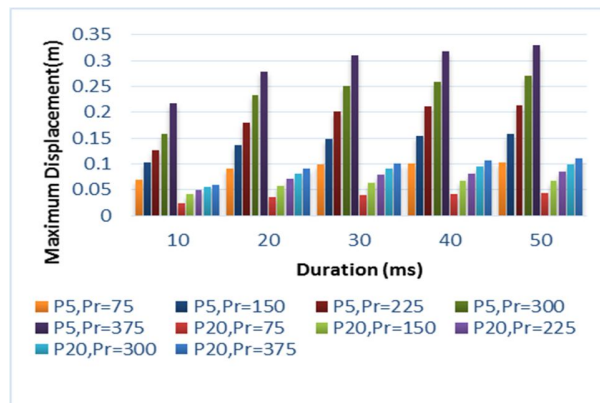

Fig. 13. Maximum displacements of P5 and P20 SPWs under various impulsive loads.

Regarding the comparison of graphs in Fig. 13 related to the SPWs with 5 and 20 mm thickness, it is obvious that the increase in thickness of plate walls from 5 to 20 mm leads to more decrease in maximum displacement. In fact, it can be obtained that the increase in the elastic stiffness of SPWs due to increase in the thickness of plate results in its maximum displacement. Also, it can be concluded that the increase in the thickness of plate decreases the maximum displacement of SPWs.

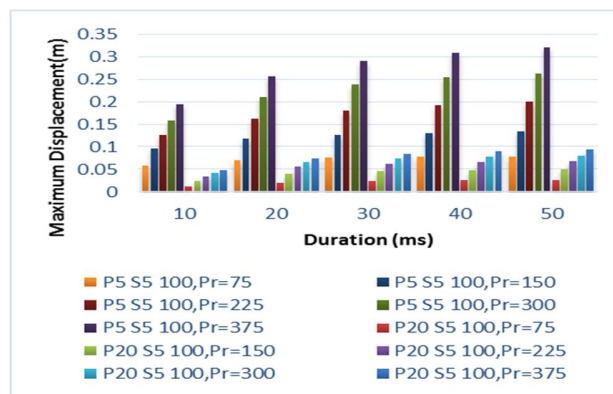

Fig. 14. Maximum displacement of P5 S5 100 and P20 S5 100 SPWs under various impulsive loads.

Fig. 14 shows the maximum displacement of SPWs of P5 S5 100 and P20 S5 100 under various blast impulsive loads. Regarding the comparison of graphs in Figs. 14, it can be stated that the thickness of the SPWs significantly impact on the behavior of steel wall in a way that the increase of SPW thickness from 5 mm to 20 mm, results in decreasing the maximum displacement. The reduction in maximum displacement of SPW affected by the increase in the thickness of plate is evident. Figs. 13 and 14 show that the stiffener arrangement has no remarkable impact on displacement of SPWs. In other words, it can be concluded that the maximum displacements of SPWs are more sensitive to thickness of plate than stiffener arrangement and change in thickness of plate has more influence on change in maximum displacement. A similar trend was reported by experimental and numerical investigations by Zheng et al. [11]. He stated that the final deformation of stiffened steel plates is more sensitive to

thickness of plate than stiffeners attached to the plate. After studying Figs. 13 and 14, it can be concluded that the duration and the reflected pressure of blast impulsive loading have a direct effect on maximum displacement of SPWs. In other words, it can be indicated that as duration of blast from 10 to 50 msec or as the reflected pressure from 75 to 375 kPa in each graph of 13 and 14 increases, the maximum displacement of SPWs increases. Having studied the effect of blast loading on the walls, it can be stated that as the duration and the reflected pressure of blast loading increases, it has more effect on maximum displacement of steel plate in which the thickness of SPWs plays an important role in decreasing the displacement. According to what mentioned from Figs. 6 to 10 and 13 to 14, it can be stated that increasing the thickness of plate from 5 to 20 mm causes to decrease maximum displacements of the SPWs and causes to increase the output impulse of the SPWs. In fact the more maximum displacement, the less output impulse. This case is related to ductility of steel plates. In 5 mm SPWs, the maximum displacement is more than the 20 mm SPWs. On the other hand, the amount of transferred impulse to main structure from the 5 mm SPWs is less than the 20 mm SPWs. This shows that the energy dissipation of the 5 mm SPWs is more than that of the 20 mm plate walls and this kind of SPW has pivotal role on the ductility.

To clarify these cases, the contours of Von Mises stress for SPWs of P5 and P20 under the most severe blast impulsive loading used in this research, with reflected pressure of 375 kPa and various time durations of 10, 20, 30, 40 and 50 msec are shown in Figs. 15-24.

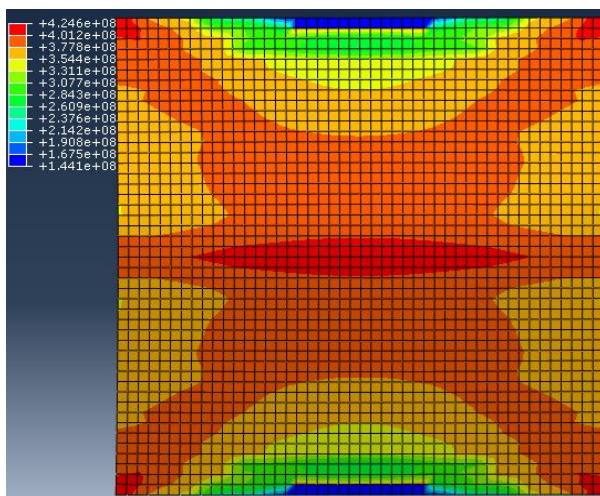

Fig. 15. Contours of von Mises stress of P5 SPW under reflected pressure of 375 kPa and time duration of 10 msec.

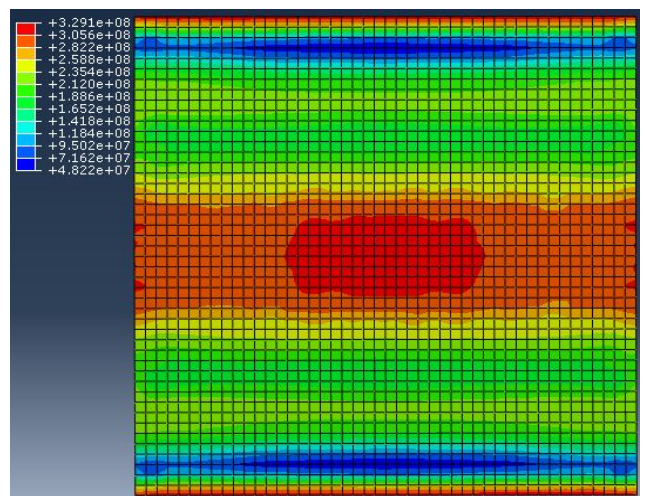

Fig. 16. Contours of von Mises stress of P20 SPW under reflected pressure of 375 kPa and time duration of 10 msec.

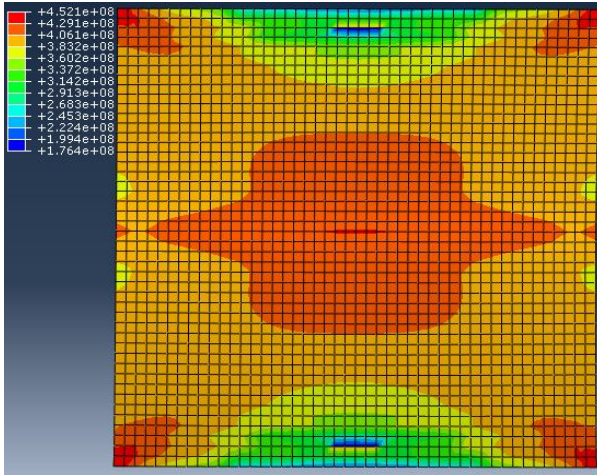

Fig. 17. Contours of von Mises stress of P5 SPW under reflected pressure of 375 kPa and time duration of 20 msec.

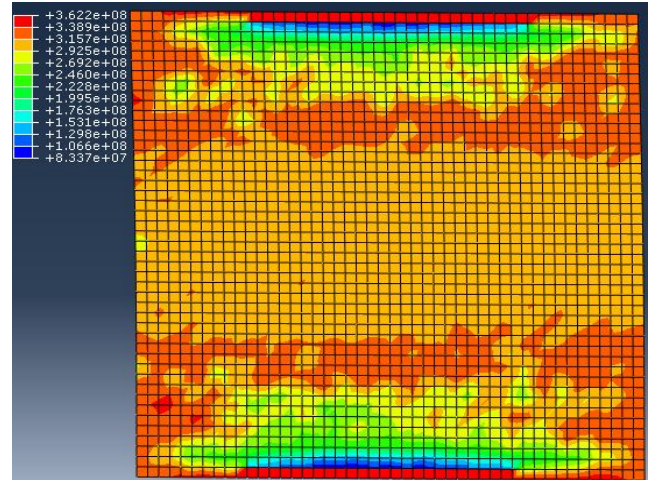

Fig. 18. Contours of von Mises stress of P20 SPW under reflected pressure of 375 kPa and time duration of 20 msec.

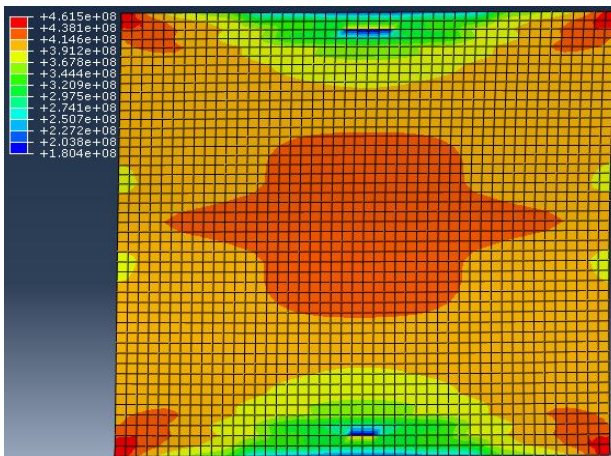

Fig. 19. Contours of von Mises stress of P5 SPW under reflected pressure of 375 kPa and time duration of 30 msec.

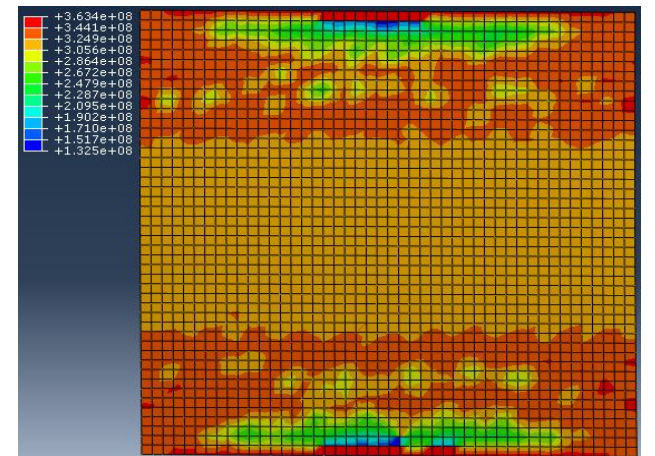

Fig. 20. Contours of von Mises stress of P20 SPW under reflected pressure of 375 kPa and time duration of 30 msec.

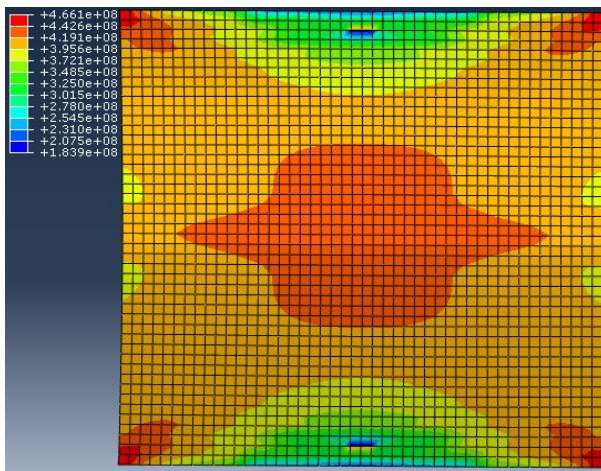

Fig. 21. Contours of von Mises stress of P5 SPW under reflected pressure of 375 kPa and time duration of 40 msec.

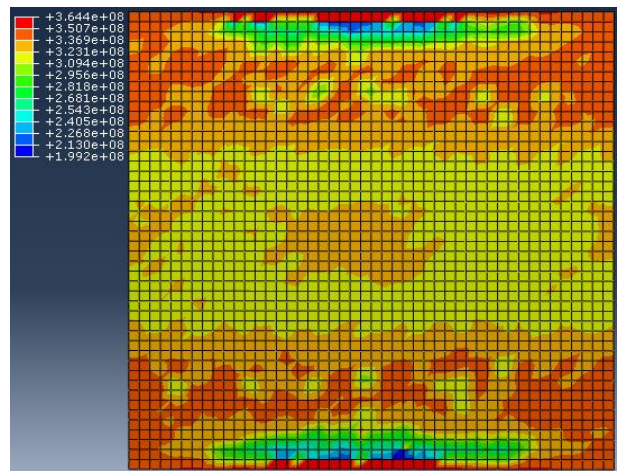

Fig. 22. Contours of von Mises stress of P20 SPW under reflected pressure of 375 kPa and time duration of 40 msec.

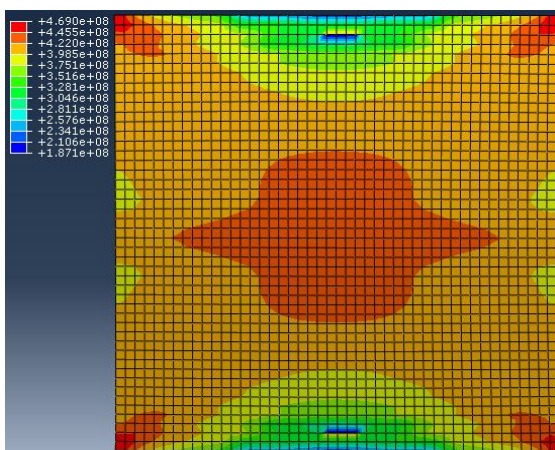

Fig. 23. Contours of von Mises stress of P5 SPW under reflected pressure of 375 kPa and time duration of 50 msec.

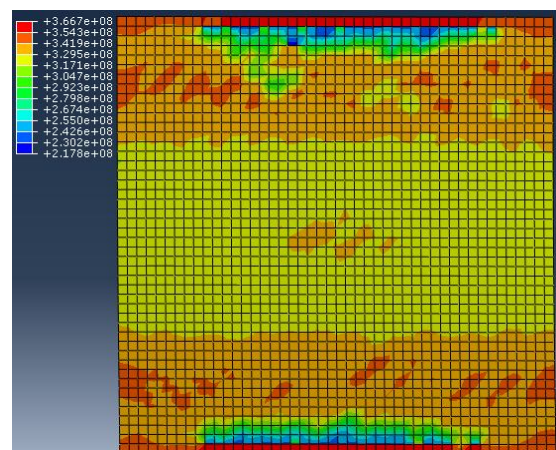

Fig. 24. Contours of von Mises stress of P20 SPW under reflected pressure of 375 kPa and time duration of 50 msec.

In Figs. 15 to 24, maximum Von Mises stresses are displayed in order to facilitate the comparison between all contours. Based on these contours, P5 SPW shows more Von Mises stress compared to P20 SPW in all time durations. For example, Von Mises stress in the P5 SPW under impulsive loading of 375 kPa and duration of 10 msec is about 28% more than that of P5 SPW. So, P5 PSW is more ductile against this kind of impulsive loading. Moreover, it has more suitable performance compared to P20 SPW. This trend is repeated in other figures. To exemplify, for the most severe impulsive loading with reflected pressure of 375 kPa and duration of 50 msec in Figs. 23 and 24, it is clear that Von Mises stress of P5 SPW is about 22% more than that of P20 SPW. According to what mentioned above, the behavior of SPWs under various blast impulsive loadings and related transferred impulse, maximum displacement and Von Mises stress were studied adequately. Investigation of transferred impulse, maximum

displacement and Von Mises Stress of SPWs shows that P5 SPW is better choice against blast impulsive loading in comparison with P20 SPW.

9. Effect of mesh size on midpoint displacement

Mesh size is one of the important parameters in the numerical simulation of blast impulsive loading. In order to investigate the effect of mesh size in this study, different sizes of mesh are used. The mesh sizes used in this study are 0.03, 0.06 and 0.12 m according to what assumed by Kadid [18]. Figs. 25 to 29 show the midpoint displacement of various SPWs with different mesh sizes under impulsive loading with reflected pressure of 75 kPa and time duration of 10 msec. In order to study mesh size effect, displacement at midpoint, one point in the center of plates, was considered.

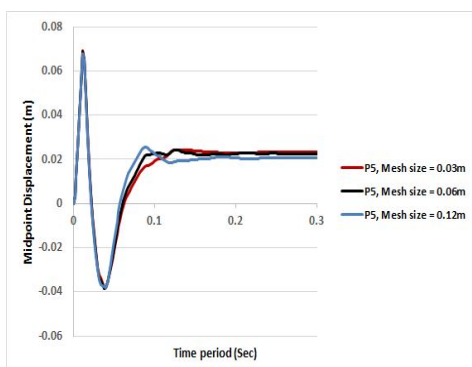

Fig. 25. P5 SPW with mesh sizes of 0.03, 0.06 and 0.12 m.

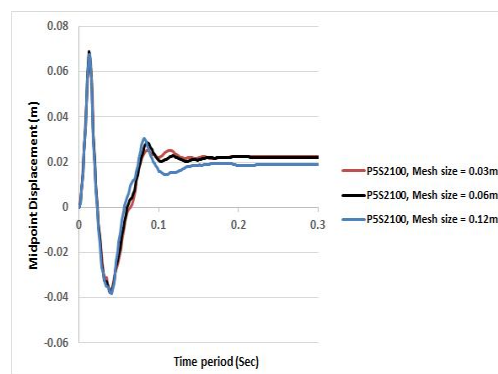

Fig. 26. P5 S2 100 SPW with mesh sizes of 0.03, 0.06 and 0.12 m.

Figs. 25 and 26 show the midpoint displacement of P5 and P5 S2 100 SPWs with different mesh sizes. It is obvious that in SPWs without any stiffener, mesh size does not have remarkable effect on the midpoint displacements. This trend is approximately repeated in Fig. 26 where effect of 0.12 meter mesh is a little more than other meshes. Mesh with size of 0.12 meter has decreased midpoint displacement of P5 S2 100. With increasing the number of stiffeners from 2 to 3, the previous trend changes and the peak of graphs in Fig. 27 decreases. Change in the peak of graphs is due to increase the number of stiffeners. In Fig. 27, the largest midpoint displacement is related to mesh with 0.12 meter size.

Figs. 28 and 29 are related to P5 S4 100 and P5 S5 100 with considering different mesh sizes. As it is clear in Figs. 28 and 29, increasing the number of stiffeners affect the midpoint displacement of various SPWs. This case shows when blast with reflected pressure of 75 kPa and duration of 10 msec occurs, midpoint displacement of P5 S5 100 SPW is in positive direction and peak of all graphs tend to residual displacement. Concerning Figs. 25 to 29, it is observed that in general, with increasing the number of stiffeners in SPW peaks of midpoint displacement decrease. Figs. 25 to 29 show that the more the number of stiffeners increases, the more the mesh size affects the midpoint displacement. This case is obvious from Figs. 28 and 29 related to P5 S4 100 and P5 S5 100. In Figs. 28 and 29, the largest midpoint displacement is related to 0.12 meters mesh size. Also, the lowest midpoint displacement is related to 0.03 meters mesh size. These figures show that increasing the mesh size causes increasing the midpoint displacement of SPWs.

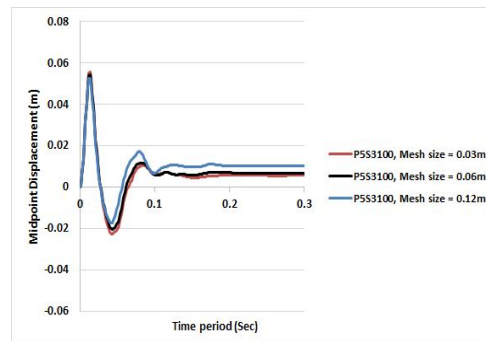

Fig. 27. P5 S3 100 SPW with mesh sizes of 0.03, 0.06 and 0.12 m.

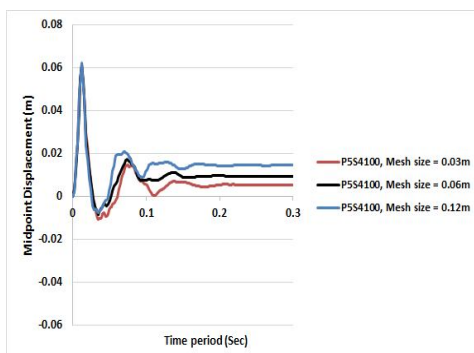

Fig. 28. P5 S4 100 SPW with mesh sizes of 0.03, 0.06 and 0.12 m.

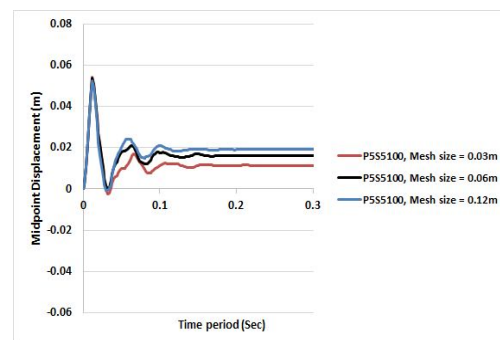

Fig. 29. P5 S5 100 SPW with mesh sizes of 0.03, 0.06 and 0.12 m.

Figs. 28 to 29 show that the more the number of stiffeners the more the effect of mesh size is obvious. In other words, effect of mesh sizes on the unstiffened SPWs is insignificant but in the SPWs with more number of stiffeners, effect of mesh size is more obvious. This trend was also stated by Tavakoli and Kiakojoori [3]. They investigated the effects of different meshes (0.04, 0.08 and 0.12m) on steel plates. They concluded that the results are not sensitive to the mesh size for unstiffened plate. However, for other models (stiffened plates), it can be observed that the influence of meshing can be important.

10. Conclusion

In this paper, the amount of transferred impulse from SPWs to main structure, maximum displacement and Von Mises stress of various SPWs with different stiffener arrangements and plate thickness were studied under various impulsive loadings. Also, effect of mesh size was investigated. Two main blast loading features including time duration and reflected pressure have direct impacts on maximum displacement and transferred impulse of SPWs. In fact, with increasing the reflected pressure of blast impulsive loading and the time duration of blast loading, output impulse of P5 and P20 SPWs increases. As blast load rises from 75 kPa and duration of 10 msec to 375 kPa and duration of 50 msec, it can be noticed that the stiffener arrangement slightly affects the maximum displacement and output impulse of SPWs. However, the SPW thickness meaningfully affects the SPW maximum displacement and its output impulse.

Finally, maximum displacement of SPW and its transferred impulse to main structure is found to be more sensitive to change in the thickness of plate rather than change in the number of stiffeners. As the thickness of SPWs increases from 5 to 20 mm in models, the amount of transferred impulse to main structure increases while maximum displacement decreases. Investigation of transferred impulse, maximum displacement and Von Mises Stress of SPWs show that SPWs with thickness of 5 mm show a better performance because more energy is dissipated against different blast impulsive loadings. In other words, these SPWs are the best choice against blast impulsive loading in comparison with P20 SPW. Also, the contours of Von Mises stress for some models were investigated in this study. Results showed that Von Mises stress in the SPW of P5 is by 28% more than that of SPW of P20. Regarding the effect of mesh size, it can be concluded that various sizes of mesh have no significant effect on unstiffened SPW. But with increasing the number of stiffener, effect of different mesh sizes is more realized.

Reference

- [1] Y. Takahashi, Y. Takemoto, T. Takeda, M. Takagi, Experimental study on thin steel shear walls and particular bracings under alternative horizontal load, in: Preliminary Report, IABSE, Symp. On Resistance and Ultimate Deformability of Structures Acted on by Well-defined Repeated Loads, Lisbon, Portugal, 1973.
- [2] H. Salim, R. Dinan, P.T. Townsend, Analysis and experimental evaluation of in-fill steel-stud wall systems under blast loading, *Journal of structural engineering*, 131 (2005) 1216-1225.
- [3] H.R. Tavakoli, F. Kiakojoori, Numerical dynamic analysis of stiffened plates under blast loading, *Latin American Journal of Solids and Structures*, 11 (2014) 185-199.
- [4] T. Sabuwala, D. Linzell, T. Krauthammer, Finite element analysis of steel beam to column connections subjected to blast loads, *International Journal of Impact Engineering*, 31 (2005) 861-876.
- [5] T.D. Hrynyk, J.J. Myers, Out-of-plane behavior of URM arching walls with modern blast retrofits: Experimental results and analytical model, *Journal of structural engineering*, 134 (2008) 1589-1597.
- [6] R.L. Azevedo, M. Alves, A numerical investigation on the visco-plastic response of structures to different pulse loading shapes, *Engineering Structures*, 30 (2008) 258-267.
- [7] I.M. Snyman, Impulsive loading events and similarity scaling, *Engineering Structures*, 32 (2010) 886-896.
- [8] H. Moghimi, R.G. Driver, Computational analysis of steel plate shear walls under accidental blast loading, in: Proc., 2nd Specialty Conference on Disaster Mitigation, Winnipeg, Manitoba, 2010.
- [9] H. Moghimi, R.G. Driver, Performance assessment of steel plate shear walls under accidental blast loads, *Journal of Constructional Steel Research*, 106 (2015) 44-56.
- [10] H. Al-Thairy, A modified single degree of freedom method for the analysis of building steel columns subjected to explosion induced blast load, *International Journal of Impact Engineering*, 94 (2016) 120-133.
- [11] C. Zheng, X.S. Kong, W.G. Wu, F. Liu, The elastic-plastic dynamic response of stiffened plates under confined blast load, *International Journal of Impact Engineering*, 95 (2016) 141-153.
- [12] P. Zhang, Y. Cheng, J.J. Liu, Y.N. Li, C.L. Zhang, H. Hou, C. Wang, Experimental study on the dynamic response of foam-filled corrugated core sandwich panels subjected to air blast loading, *Composites Part B: Engineering*, 105 (2016) 67-81.
- [13] T.P. Nguyen, M.T. Tran, Response of vertical wall structures under blast loading by dynamic analysis, *Procedia Engineering*, 14 (2011) 3308-3316.
- [14] ASCE, Design of blast-resistant buildings in petrochemical facilities, ASCE Publications, Petrochemical Committee, Task Committee on Blast Resistant Design. New York, NY: American Society of Civil Engineers., 2011.
- [15] J.M. Biggs, B. Testa, Introduction to structural dynamics, McGraw-Hill New York, 1964.
- [16] R.W. Clough, J. Penzien, Dynamics of structures, vol. 2, in, McGraw-Hill New York, 1993.
- [17] A. Markose, C.L. Rao, Mechanical response of V shaped plates under blast loading, *Thin-Walled Structures*, 115 (2017) 12-20.
- [18] A. Kadid, Stiffened plates subjected to uniform blast loading, *Journal of Civil Engineering and Management*, 14 (2008) 155-161.