

DIRECT SEQUENTIAL SYSTEM ASSEMBLAGE

by
Daniel M. Sandomire
Bachelor of Arts in Architectural Studies
University of Washington
Seattle, Washington
June 1994

SUBMITTED TO THE DEPARTMENT OF ARCHITECTURE
IN PARTIAL FULFILLMENT OF THE REQUIREMENTS FOR
THE DEGREE OF
MASTER OF ARCHITECTURE
AT THE
MASSACHUSETTS INSTITUTE OF TECHNOLOGY
FEBRUARY 1997

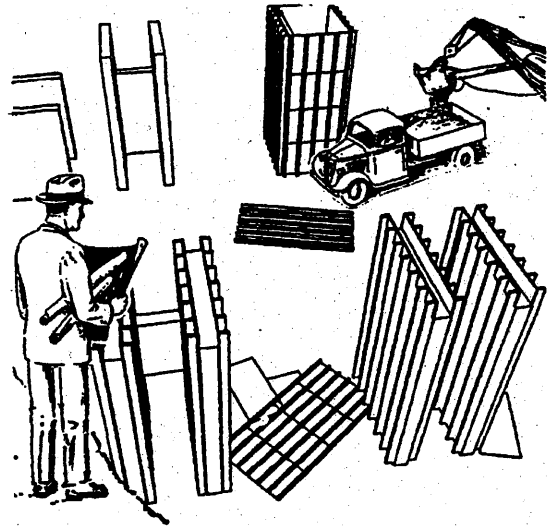

© DANIEL M. SANDOMIRE 1996. All rights reserved.
The author hereby grants to M.I.T. permission to reproduce and to distribute publicly paper
and electronic copies of this thesis document in whole or in part.

Signature of the Author

Daniel Sandomire
Department of Architecture
January 15, 1997

Certified by

Maurice Smith
Professor of Architecture Emeritus
Thesis Advisor

Accepted by

Andrew Scott
Chairman
Departmental Committee on
Graduate Students

MASSACHUSETTS INSTITUTE OF TECHNOLOGY

MAR 26 1997

LIBRARIES

READERS

Halasz, Imre: Professor in Architecture Emeritus.

Hubbard, Bill: Visiting Associate Professor In Architecture.

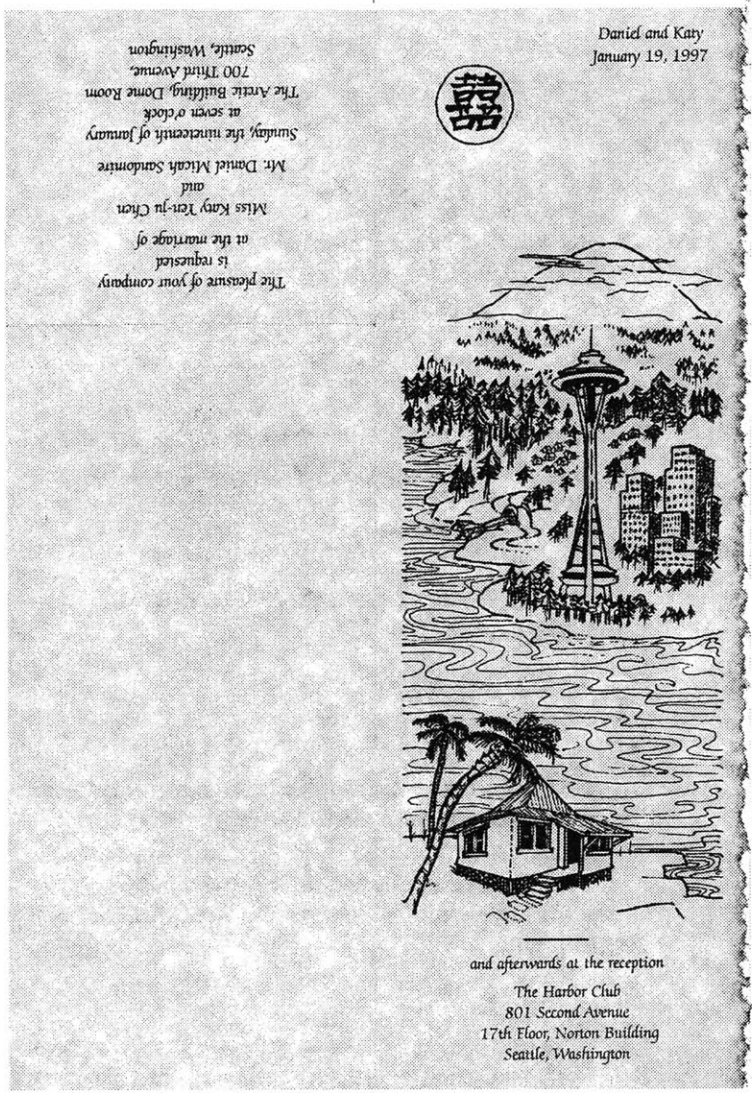

Daniel and Katy
January 19, 1997

The pleasure of your company
is requested
at the marriage of
Miss Katy Yen-ju Chen
and
Mr. Daniel Michah Sandomire
Sunday, the nineteenth of January
at seven o'clock
The Arctic Building, Dome Room
700 Third Avenue,
Seattle, Washington

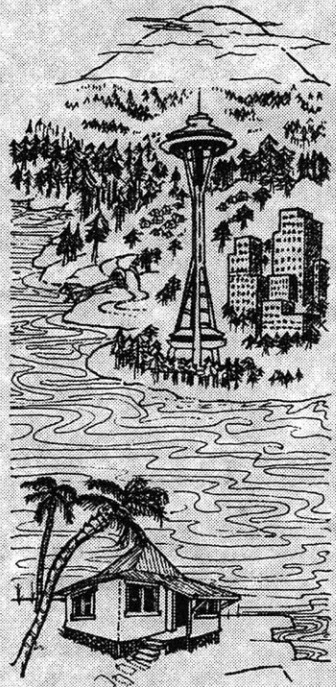

and afterwards at the reception
The Harbor Club
801 Second Avenue
17th Floor, Norton Building
Seattle, Washington

Forward...

This brief note is, in fact, the most important message this document bears. This thesis remains as a marker of my education, an indicator of where my investigations left the school and propelled me forward. To my friends here at M.I.T. - I look forward to working with you. To my professors - I thank you for what you have taught, and look forward to teaching it to others. And to my family - both the family I grew up with and the family I am now making - I thank you for your patience and support, and look forward now to being with you.

Daniel Sandomire
Cambridge
January, 1997

DIRECT SEQUENTIAL SYSTEM ASSEMBLAGE

by
Daniel M. Sandomire
Bachelor of Arts in Architectural Studies
University of Washington
Seattle, Washington
June 1994

SUBMITTED TO THE DEPARTMENT OF ARCHITECTURE
IN PARTIAL FULFILLMENT OF THE REQUIREMENTS FOR
THE DEGREE OF
MASTER OF ARCHITECTURE
AT THE
MASSACHUSETTS INSTITUTE OF TECHNOLOGY
FEBRUARY 1997.

ABSTRACT

Decisions made during the building process have the opportunity to both inform the next set of decisions and provide unexpected and possibly positive features in the final project. Thus, working beyond the minimum definition at each size will provide a more rich environment for the next...

This thesis proposes to investigate those decisions both analytically and synthetically. In volume one, construction phases are established and a set of physical system options is assigned to each. The next task of the thesis is to assemble these systems in multiple, thus discovering both the intrinsic behaviors of the system as well as its means of exchange with other systems. These parallel systems investigations will then provide the background for the final task of this thesis: volume two, a practical application of the methodology in an architectural project.

THESIS ADVISOR:

Maurice Smith
Professor in Architecture
Emeritus

TABLE OF CONTENTS

01	Title.
03	Abstract.
04	Forward.
05	Table of Contents.
06	Introduction.
11	Building References.
23	System Catalog.
54	Parallel Systems Investigations.
63	Conclusion.
64	Appendix of Potential Exercises.
78	Illustration Credits.
79	Bibliography.

“You have first of all to side with your own spirit, and your own taste. Then you take the time, and have the courage, to express all your thoughts on the subject at hand (not just keeping the expressions that seem brilliant or distinctive). Finally you have to say everything simply, not striving for charm, but conviction.”

- *“Memorandum,”* by Francis Ponge, Proems.

INTRODUCTION

Historically, the act of building is informed by its immediate physical context and the behavior of the physical elements at work. Reflective and self referential, a traditional process would be adapted to the particular situation in which the builder found himself. Buildings grew out of a dialogue between intended uses and the physical means to achieve that use. Both the process and the products were directly and physically associative.

Enter into this the modern agenda. Commodity exchange reduced everything to numbers, efficiently and relentlessly. Buildings became abstract problems for which solutions could be engineered. Engineering replaces building. Economic constraints promote the design of the minimum. Structures are sized to exact calculated dimensions. The end goal resultant is minimal and predictably so. Options - if they are even available - are so limited as to make them a joke as well. Modifications within the buildings after the construction are difficult if not impossible, especially since these sorts of buildings are regulated by people other than those living there. The building becomes an extension of the governing powers - actual physical control as well as political and social.

One of the most shocking examples of this attitude is found in the conception of Total Architecture. This is the belief that there are building and assembly systems that will be complete and satisfy all the requirements a habitation could have. The elements of a system, touted as being statically integrated and monolithic, add up to just that: a static, integrated, and monolithic building. This mind set pursues red herrings such as universal connections. Each development this attitude makes for itself is one more step away from the issues of built form. Total Architecture is complete unto itself: closed and unresponsive to the rest of the world (*see figure 1*).

Direct Sequential Systems Assemblage is a proposition that works within the modern construction industry and provides the associative presence that traditional building technologies do. Rather than strive for a Total Architecture, the systems employed are open and incomplete. Each

system is able to survive on its own, and is intensified by the presence of the next. And the two systems exchange through the one true "universal connector" - space. Advocating the continuity of light and landscape at every size, systems are deployed both generically and specifically. By achieving a recognizable norm at the larger size, but with attention and consideration of the particulars involved in the smaller sizes, the resultant building benefits both from the economy afforded by prefabricated systems as well as the arms-length habitable qualities of the construction.

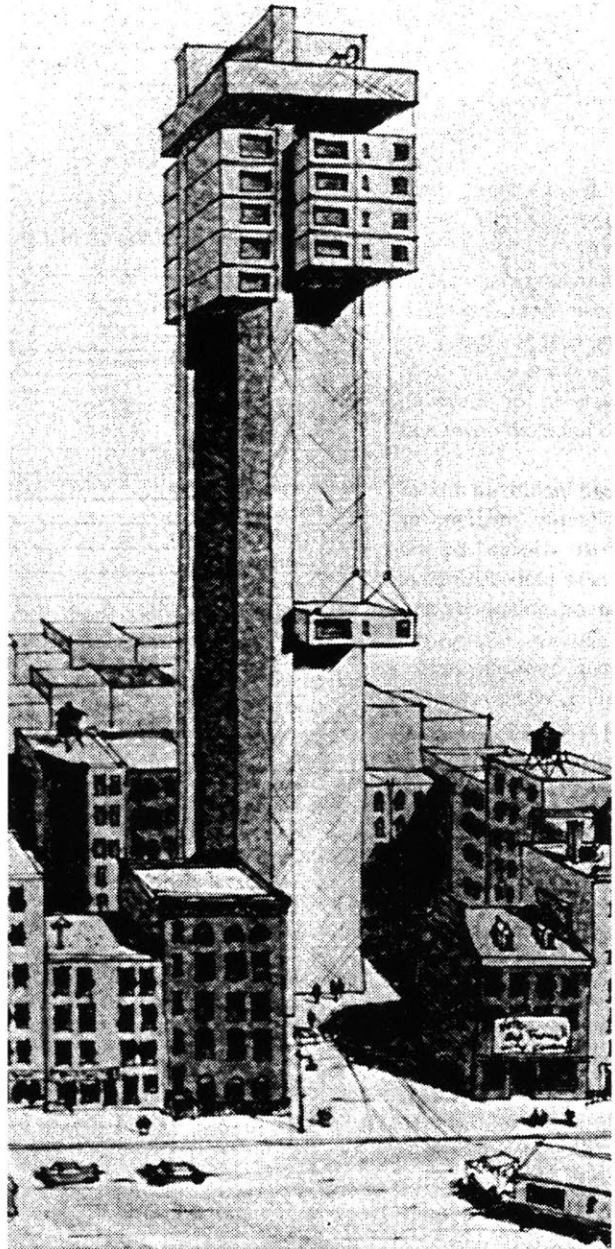

Figure 1. *The enemy.*

It was in the building boom following World War II that a new systems - building began to develop. The modernist agenda clearly called for a "new" building. New technologies, new methods, and a new lifestyle could all be - in fact, would all be - achieved with the new modern means now available. This heroic view of themselves as builders and inventors propelled man architects and engineers of the day into the pursuit of the minimum - which is exactly what they got.



Figure 8.1. Dwelling with low surface to volume ratio.

Minimum to some meant minimum surface area, which in turn meant minimum territorial definition. Or perhaps the minimal seeking builder sold off the glass in order to save on prefabrication and transportation costs. In the end, a lot was sold. Too much.

The engineering approach is to take a problem apart (this operation is usually performed by a systems engineer). The disassembled parts are then sent to engineers who specialize the the preselected area. Integration is investigated by a series of categorizations. In order to synthesize the project, a complete dissection is called for. This engineering approach may provide for individual component design success, but does not necessarily yield a whole - or holistic - project (see figure 8). One easy answer to this quandary is to do away with the aspect of integration, and promote independent systems instead.

One problem with integration it technical concentration and mechanical failure. The Arab World Center is the best example of this - each tiny motor in the solar active screen baked itself, and cannot be accessed for repair. A number of different factors of enclosure - sun shading, wind buffer, water seal - were smashed together into a tiny, almost biological, singular system.



Figure 8.2. Here a communications engineer and structural engineer got together and solved all their problems with one fell swoop.

Rather than take the approach of component integration, what if the systems themselves were physically independent, but added up to an integrated - or holistic - total. By treating each phase as an intensification improving an existing "landscape," the building will be better adapted to its site and context. More spatial variation and more territorial definition are also a result. Each system, surviving on its own will provide a positive and associative presence for the inhabitant. This, I believe, is a much more positive and practical use of appropriate technologies.

The challenge of our day is not to house the masses - this has been solved. Policy can now take care of that. But the real challenge is to provide reasonable, habitable and dignified buildings. Shelter, we can now see, is not just against climatic elements. There are issues of cultural context, social standing, public and private - and so on. The sooner the builders of our time embrace these issues and take them to their hearts, the sooner we can all begin investigating the more positive aspects a systems approach has to offer: variety through options.

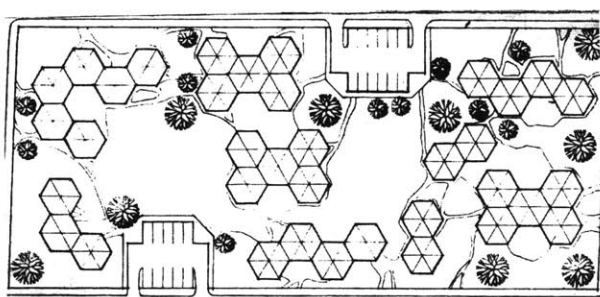
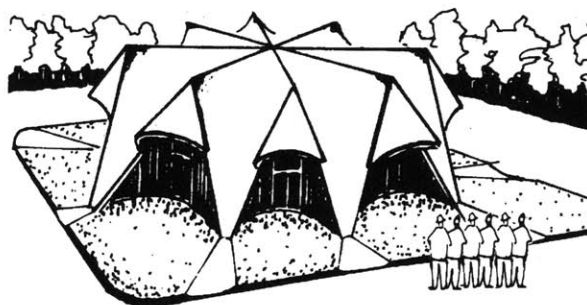
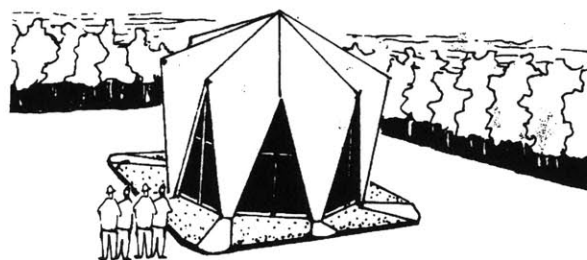

Figure 9.2: Where the single element becomes the universal spatial generator. Note the cellular growth of the scale figures.



Figure 9.1: Where the single element becomes the universal spatial generator.

BUILT-WORK REFERENCES

This section covers built references dealing with sequence in construction. It has been established that building is a reaction to, or intensification of, a site. The built site, while not deterministic in future operations, certainly will influence the more worthwhile options available. Accepting this hierarchy dictates that an additive attitude will yield understandable and recognizable form.

The following five examples help to illustrate some forces behind and benefits of phased, or sequenced construction and additive assemblage. The reasons vary from the most basic requirements of shelter to cost - benefit analysis, to formal investigations and so on.

The first example looks at traditional building development in rural Afghanistan. This historic record shows explicitly the existence and reasoning of a long standing tradition of sequential assemblage. The next example is a modern high density project in an urban setting. It proves that sequenced construction can be profitable and desirable for tenants. Following this is a survey of Greek village building systems from a typological approach. It begins to show how a generic building system can have a number of optional particularities. These particularities, when added up over the whole of the town give a richness and spatial variety unforeseen in the original individual building element.

CASE STUDY #1 qawwal: from tent to hut

In the book Traditional Architecture of Afghanistan, one of the observations the author documented is the sequence of dwelling evolution for migrant worker - or Qawwal - dwellings.

Following the crops, and working on other people's land, the Qawwal live in traditional tents: easy to pack up and move on for the next season. As it develops, some of the Qawwal decide to stay near a particular town for whatever reason - odd jobs or more work - and establish themselves. The following is an excerpted from Traditional Architecture of Afghanistan, p. 55:

DWELLING EVOLUTION

First the pup tent is set up in the manner in which it was designed. If the stay in the city is for as little as overnight of a few days, this stage suffices. If the stay appears to be extending, because of available work in nearby fields or the possibility of securing a job, a small mud wall, often no more than 25 centimeters high, is built around the edge of the tent. Little by little, the wall grows higher, until the tent becomes a roof. Eventually the tent roof is taken off and replaced with a simple wooden pole and mud roof: a hut has emerged. Soon these huts combine to form the miscellaneous rooms of a house surrounding a small court for privacy and cooking.

At the end of the seasonal stay, most of the migrant workers abandon their half-tent, half-hut, but those who remain build more complete housing units other parts of the site. This activity could indicate the beginning of a squatter problem.

The same constructional sequence can be seen on the outskirts of Kabul and in other areas where migrant workers appear to have settled for a considerable part of the year. Their camps are sometimes no more than rows of white tents, half-tent, half-hut combination, depending upon the duration of their stay.

Sequence, in this example, is most strongly a factor of convenience and commitment. A simple, primary system - the pup tent - is deployed quickly on the site. This allows the user to quickly inhabit the site and make choices from there. The option to build is made gradually: building takes time and money, and is not a light decision. Once the commitment is made, the option to continue or not is still available, each phase being stable and habitable by itself.

This self stability - territorial, physical, and habitable, is an important factor. The physical presence of the user necessitates an attitude for the building that most built projections don't have: these decision are extremely informed, and very *real*. When the designer suspends his disbelief, he will find himself in all sorts of troubles. Despite the huge limitations it sets, direct responsibility to every issue of the site is crucial.

The fact that the systems employed are traditional, or generic, is also key. Once built, the hut will remain for the next inhabitant, or generation to add to.



Figure 12. Hut-tent dwelling in Afghanistan.

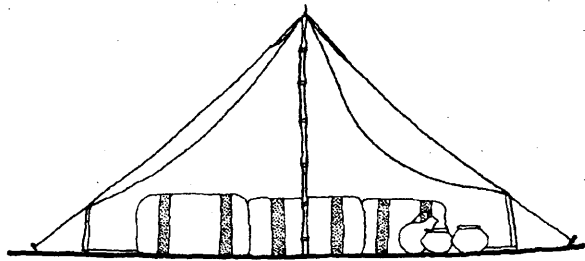

Pup tent.

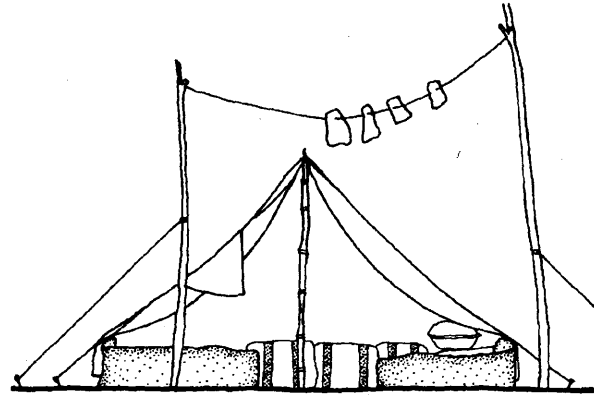

Low perimeter wall.

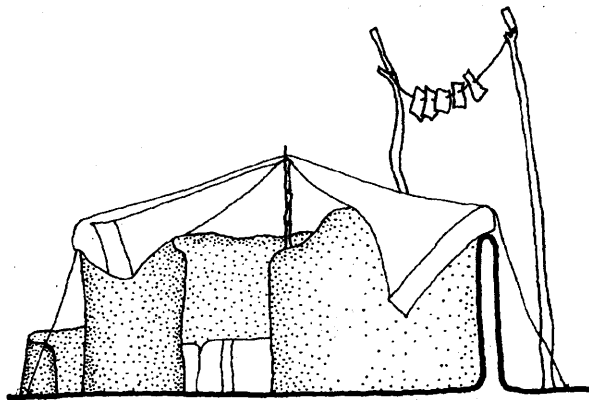

Roof.

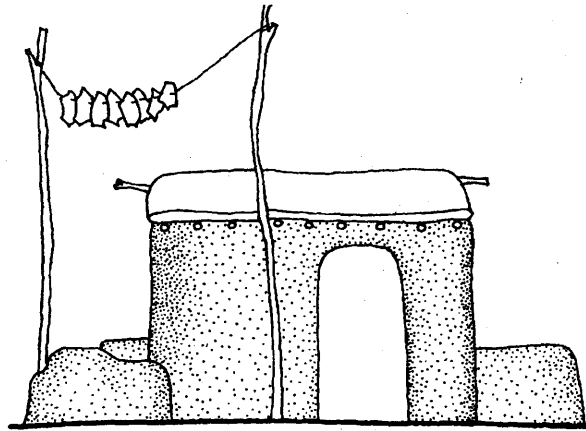

Mushrooming wall.

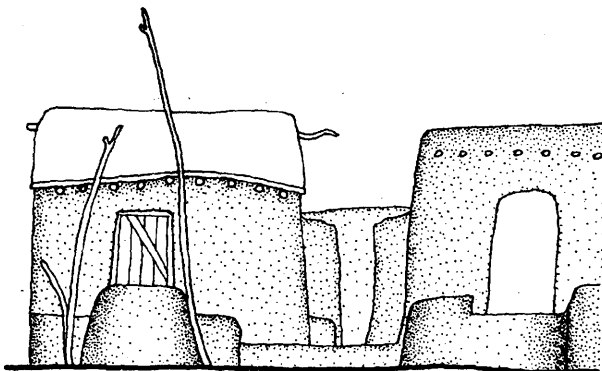

House.

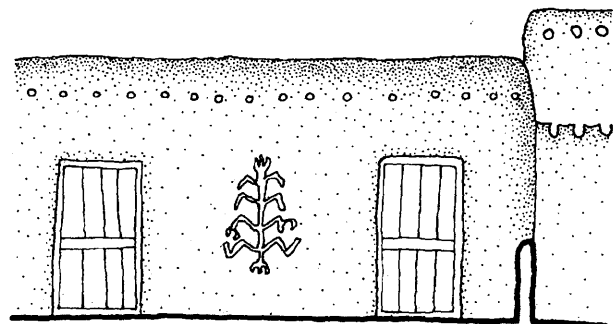

Complex of huts.

Figure 13. Dwelling Evolution of the Qawwal.

CASE STUDY # 2

next 21, osaka, japan

“1>Outline of the NEXT21

Next 21 is an experimental housing scheme which aims to provide a stage for continuing experiments to find viable solutions to the housing requirements for the next century.

The project was sponsored by Osaka Gas Co. and construction was completed in October 1993.

The project team first of all envisaged an overall building form which would be long lasting and remain a consistent part of the townscape whilst allowing for perpetual alterations to individual houses. A different architect was commissioned to design each of the 18 housing units in order that the development as a whole would represent a wide spectrum of proposals for urban living.”

-from “Next 21 Housing Report”



Figure 14. Next 21 Housing Project.

The Next 21 proposal used phased construction to allow different designers to act at different times. This creates great volumetric variety considering its standardized, repetitious frame.

The figure to the right shows the generic support system: a skeletal frame, repeated on the site. The individual cells begin to describe a building volume, but there is some slack between most bays. This allows of the secondary system to cantilever past the first, allowing for some exchange between the two systems.

This slack is necessary to definitively set the sequences apart. Otherwise, the very first move on the site will determine the next, and so on (up to the next 21, one might gather). An end-result goal will be achieved.

In a similar scenario, if the first design team had told the subsequent teams exactly where the enclosure had to be, spatial options would be severely limited. With the spatial options so limited, the only impact a designer can have is cosmetic. This is the case in most commercial development, and gives rise to such delirious fantasies that one can observe in malls or much work done by the interior decorating profession.

The Building System

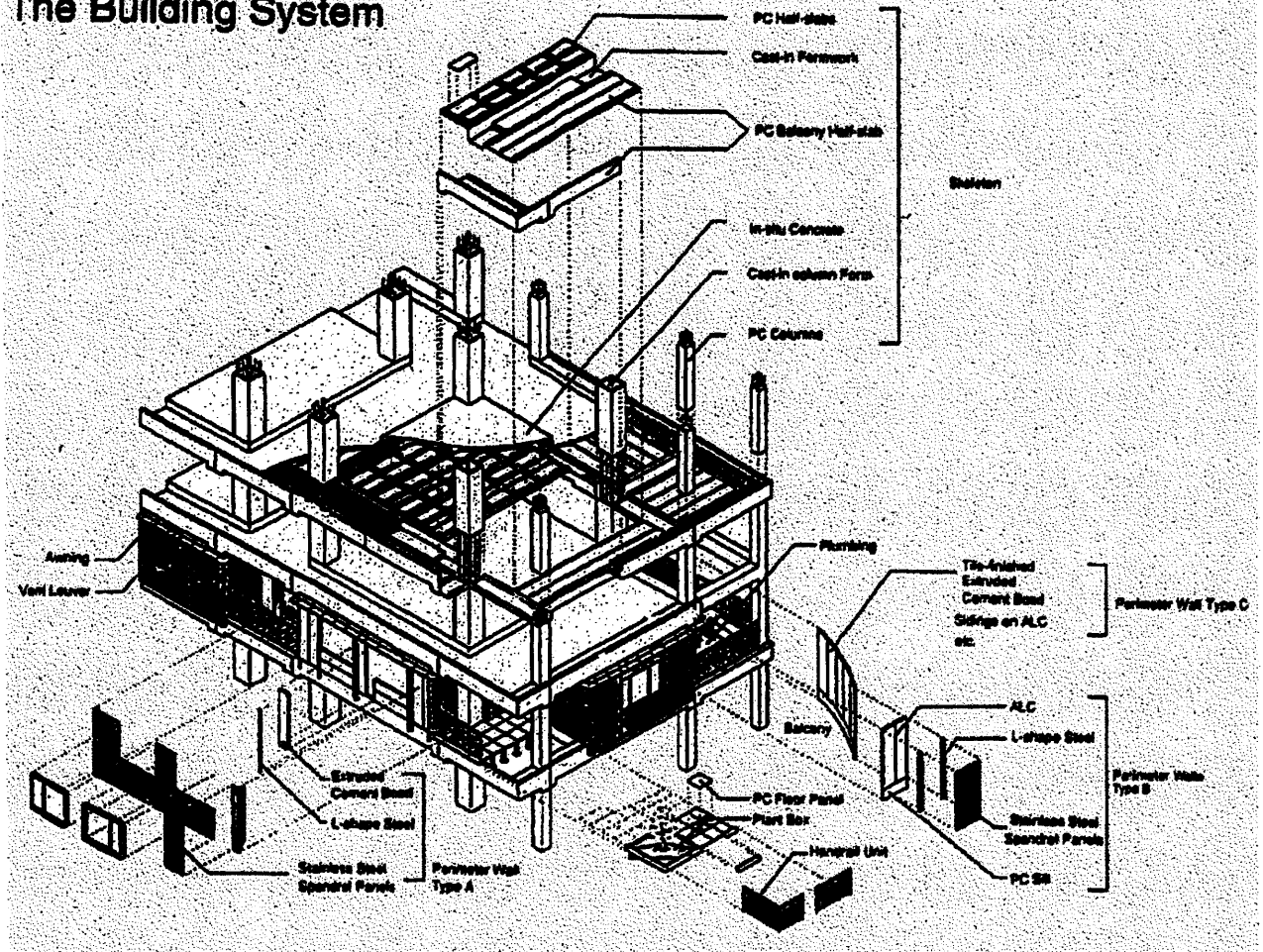

Figure 15.1 Next 21 Building Component Diagram

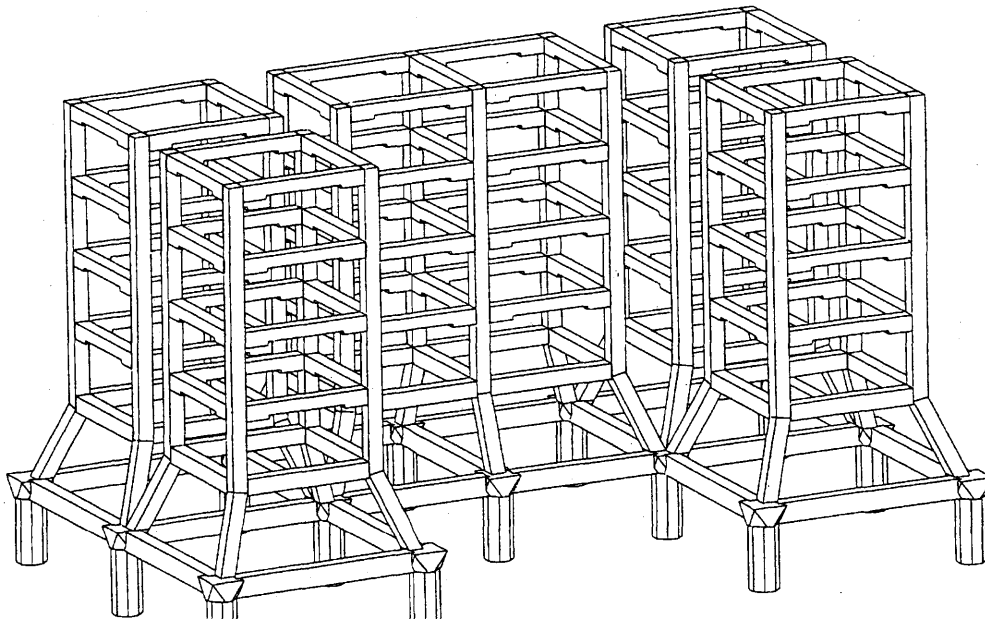
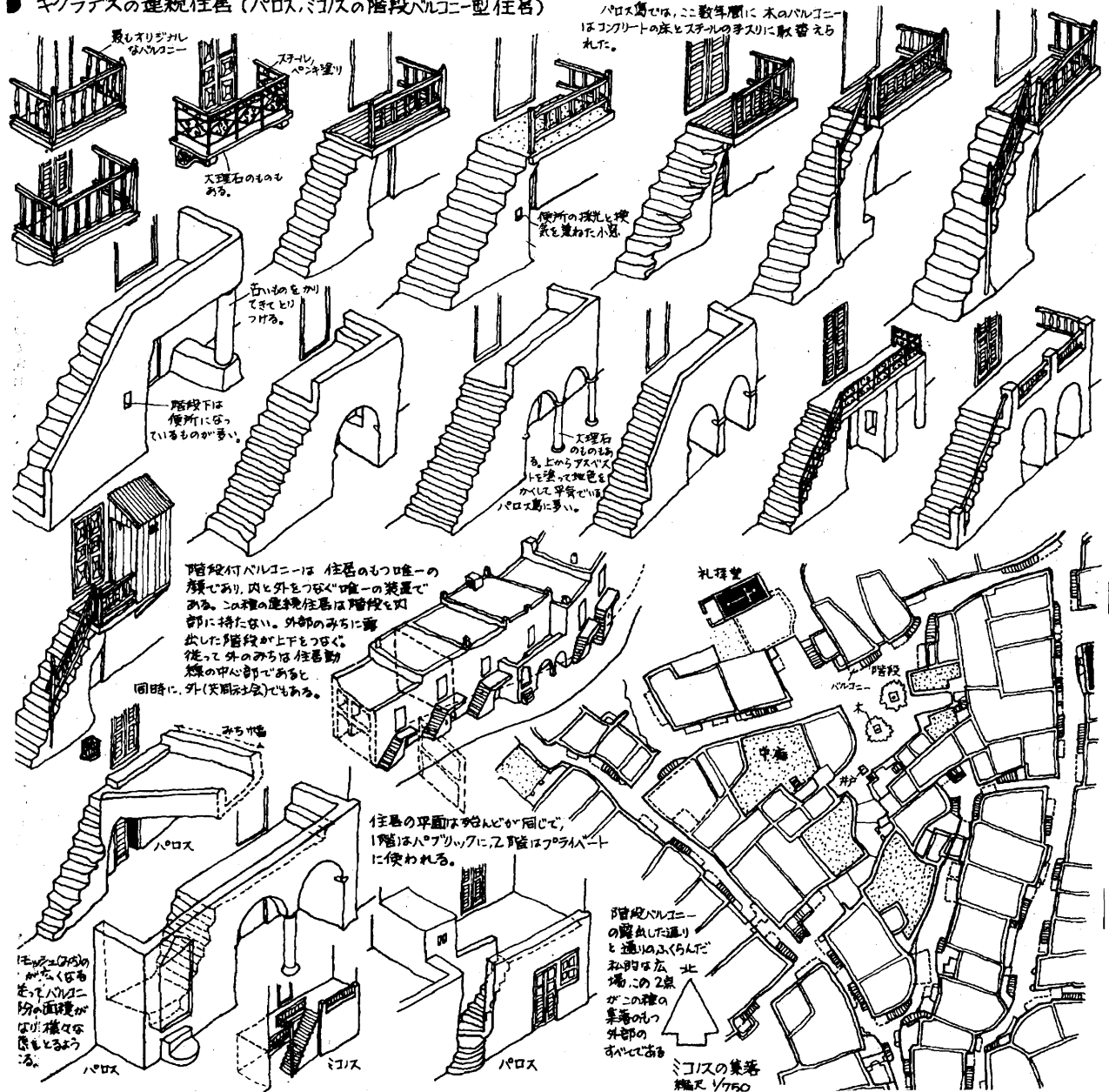

Figure 15.2. Primary support system for Next 21.

CASE STUDY # 3 greek village catalog

In this 1973 study published in SD2, the architects made direct physical observations of a Greek village. By looking at everything, and cataloging the elements by their use/form, the study successfully demonstrates several important understandings: generic attributes, specific (or particular) options within that generic, and additive formal behavior.

● キクラデスの連続住居 (パロス, ミソスの階段バルコニー型住居)



By cataloging the various elements in this example (figure 16), a whole range within the stair element is documented. The generic behavior of a staircase running parallel to a wall provides a covered entrance below, and a landing above. These buildings they begin to transform into balconies, bridges, gain some cover, or add up to an arcade. Each staircase of this type - when applied to a different option - adds up to a larger field reading, Not all the same, but a range of members of the same family.

Figure 16. Catalog of staircase options.

In looking at the additive nature of room - sized cells, the study here in figure 17 looks at some particulars which separate each cell's behavior from the next. The exchange between public and private - both vertically and horizontally - establishes the basis of the various types. Deploying the different types additively creates even more possibilities. For example, Type A + Type B creates a new Type => the whole is greater than the sum of the parts. And the field reading allows the individual parts surviving to also include the reading of that whole.

● キクラデスの住居 (アプロー子の類型)

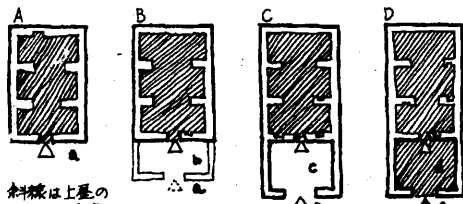

斜線は上屋のあることを示す。

上記の6つのパターンは住居(独立家屋)を任意に集めて住居の内と外をつなぐ部分の性格によって環境化したものである。ここでは住居内に入る際の動的な経路形式とその環境のみが考慮されており、その内容やスケールについては一切考慮されていない。従って住居内の平面形式についても内部以上の意味はない。

4つの要素の様々な組合せのほかで、キクラデスの独立家屋(陽家と壁を共有しない)の持つ統合形式はA~Fの6種類に限られる。AからFに至る階位は内と外とのより直接的な結合から複雑な結合に至る図式的な過程を示している。Aは独立した家屋においては一般的ではなく、荒地に孤立する家屋以外には殆ど見られない。Bは最も最もで普遍的に見られる形式である。図1は概ね内側から40~50cm程度の低いもので、履かせるスケールに合わせてある。Cは既述の住居の集った地域で見られる形式で、隣壁の内部Cはパティオやコートの特徴を要する。Dは住居へ入る入口の部分が完全に囲われた外部を要する。Eは半円形のパティオやコートをもつものが多い。FはD形式の前部にコートをもつものである。E、Fの場合は殆ど2階建てである。AからFへと移行するにつれて内部が複雑化するが、それに合わせてa~dによって形成された縦横の領域は洗いや戸、窓、花壇などによって動的な色彩を帯びてくる。そして、C以下の形式では屋上の生活もこの縦横領域(内と外とのあいだ)が程よいようになる。C、Fを除く他の形式は屋上から縦横領域に視線が及ぶのが一般的であり、その意味に依り開放型であると考えられる。他方C、Fは比較的住居が密集した場所に見られることもあり、パティオへ入る部分にゲートが設けられる場合が多い。2階建て住居では1階部分はB~Fの形式をとり得るが2階部分は殆どB形式に限られている。この場合、2階部分のaはパティオあるいはバルコニーであり、必ずこのパティオあるいはバルコニーへ繋がる階段が外部に露出し、決して住居内部にとり込まれることはない。材料や建て方の一足先のキクラデスの住居に於いては、内部空間の表現や内容及び住居動線の差異はほぼ認められず、むしろ内部と外部とのあいだとなる縦横領域に住居の意味や見聞上の差異が集中している。

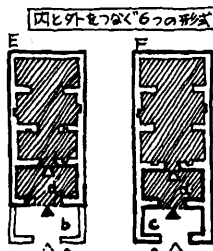

住居の内と外をつなぐ部分の要素として、a~dの4つがあげられる。aは全くの外部、bは住居の使用領域を示す程度の低い仕切り、cは外からの視線を遮る高い壁、dは上屋のかかった囲われた外部

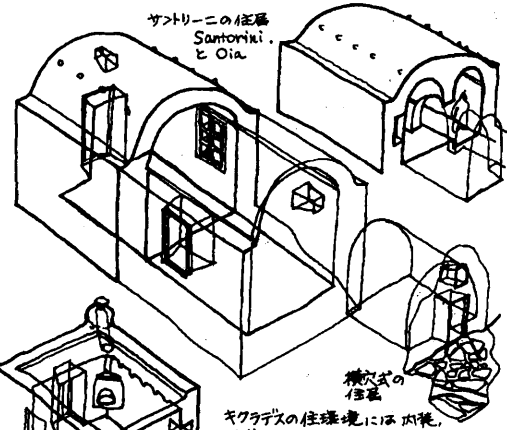

キクラデスの住居環境には内装、外装といった使用材料を区別する概念はない。石を積み上げて壁を上げ、内外の区別が自然なアースを壁に委ねてしまっている。従って外部が外部に露出し、内部と外部のスペースが無意識のうちに融け合っている。

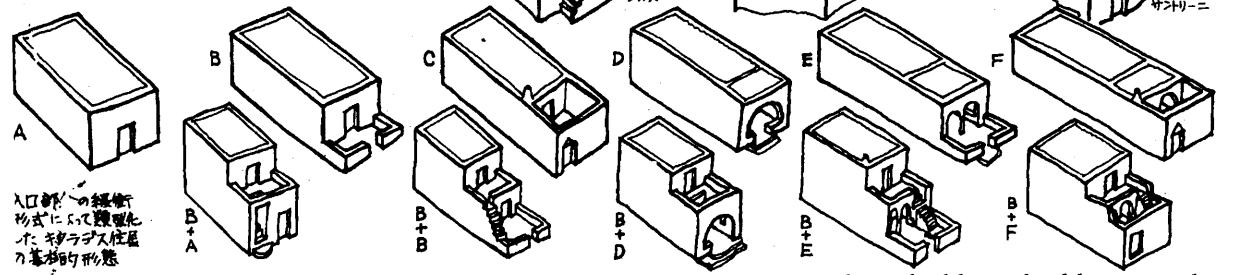
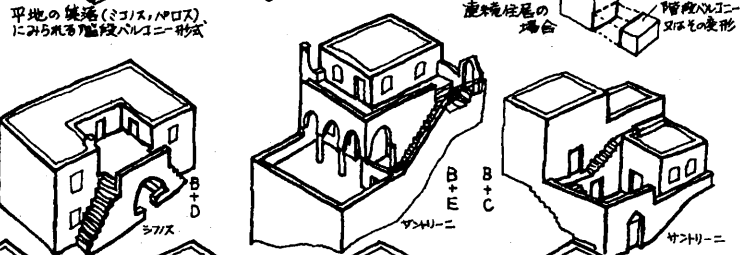
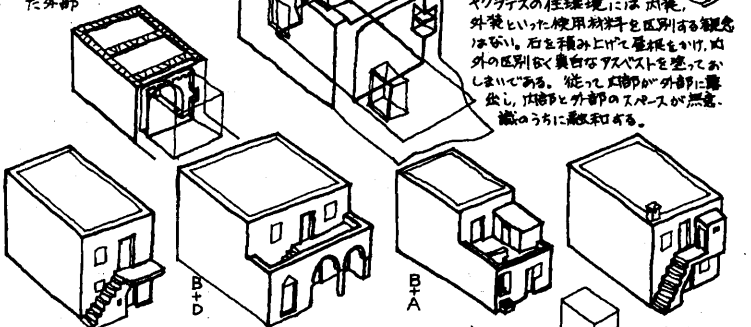
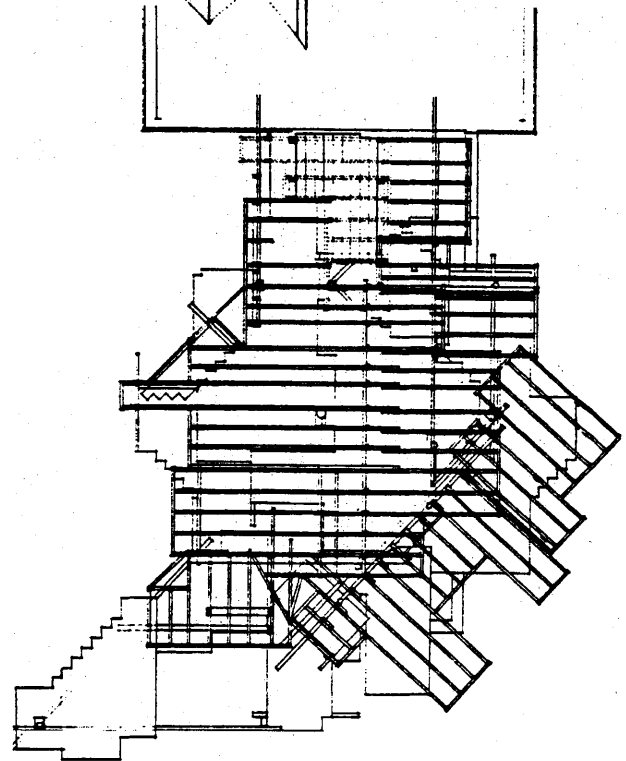
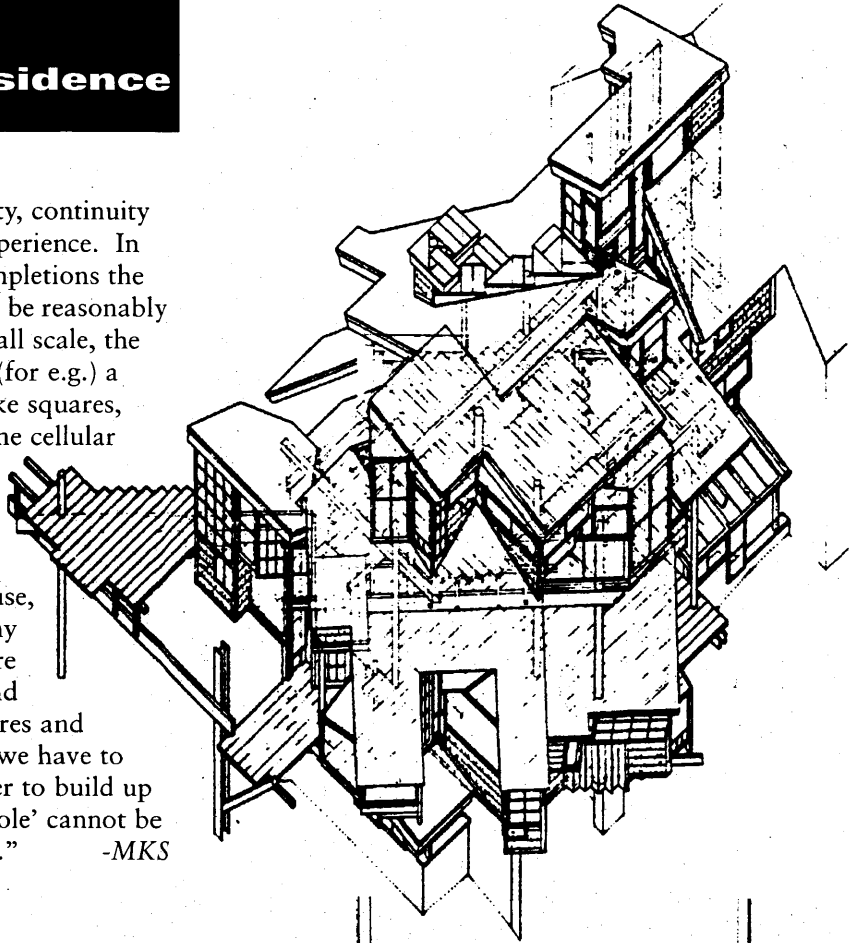
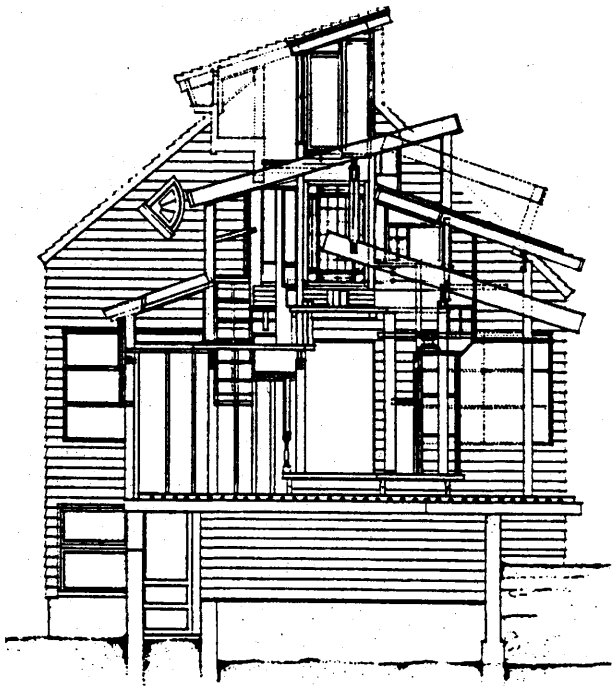

Figure 17. Catalog of additive building size elements

CASE STUDY # 4 harvard mass. residence

“We’re trying to design for continuity, continuity of life and optional continuity of experience. In this demand for multiple partial completions the strength of finite definition can only be reasonably used for stopping ‘points’... At a small scale, the same principle applies. If we make (for e.g.) a house of recognizable geometries, like squares, requiring movement directly from one cellular definition to another, we would impose sequential discontinuity. So <complete> geometries like squares are most sympathetically used to make <ends> or <stops.> In this house, there’s consistent incompleteness of any geometry *except* in the details. There are thresholds, building materials and surface (tiles, etc.) that contain squares and occasional windows, but in general we have to move about to see additively in order to build up an associative completion. The ‘whole’ cannot be experienced from any one position...” -MKS



Figures 18.1, 18.2, + 18.3. Harvard house addition plan, section, and axonometric.



Figures 19.1 + 19.2. Photographs of the addition at Harvard, Mass.

CASE STUDY # 5 deployable structures

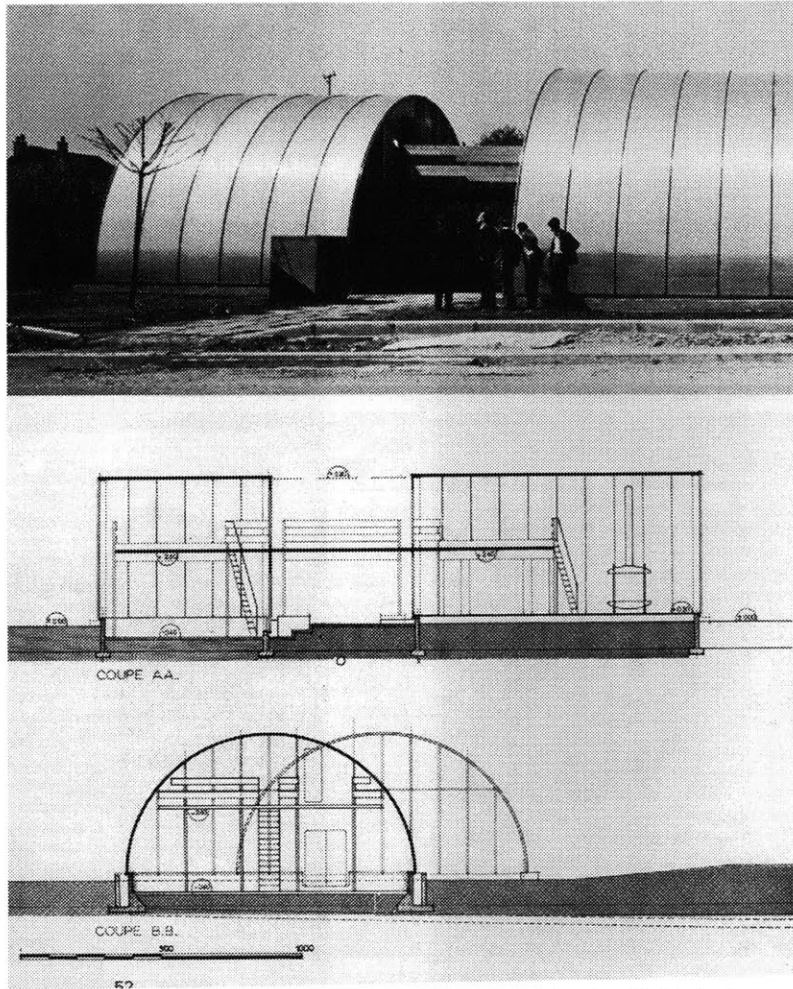

Figure 20.1 Youth Center, Paris, 1952, J. Prouvé

In this work, Jean Prouvé demonstrates phased installation of independent structural systems. The first deployment is a perimeter wall foundation with a floating slab. These ground forms make up the new landscape for the next system. This second move is an aluminum - polystyrene - wood composite sandwich barrel vault. The interior frame system of steel tube and wood gives territorial definition to the extruded volume.

By deploying a large, enclosing structure quickly on the site, habitation is greatly facilitated and accelerated. Using prefabricated elements also means less time for construction and fewer site

conditioned moves. This quonset hut, as a generic volume, allows for the flexibility of having a mezzanine - or not - as shown in coupé BB. Rather than deploy the entire compound as a single extrusion, there is a segmented displacement. This allows for light in the center, and exchange between the inside and outside. And it is at this point also, where the second system survives on its own - building the continuity from one privacy to the next.

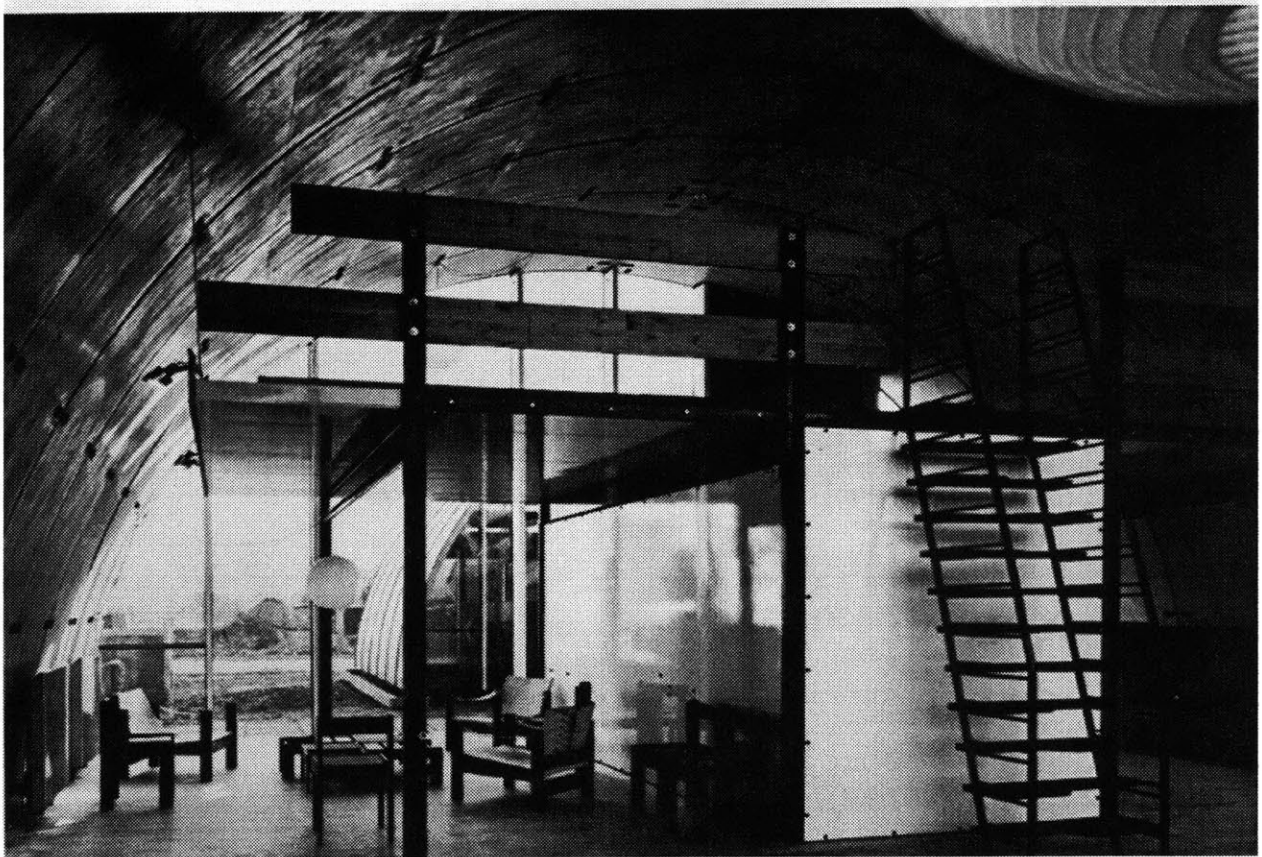
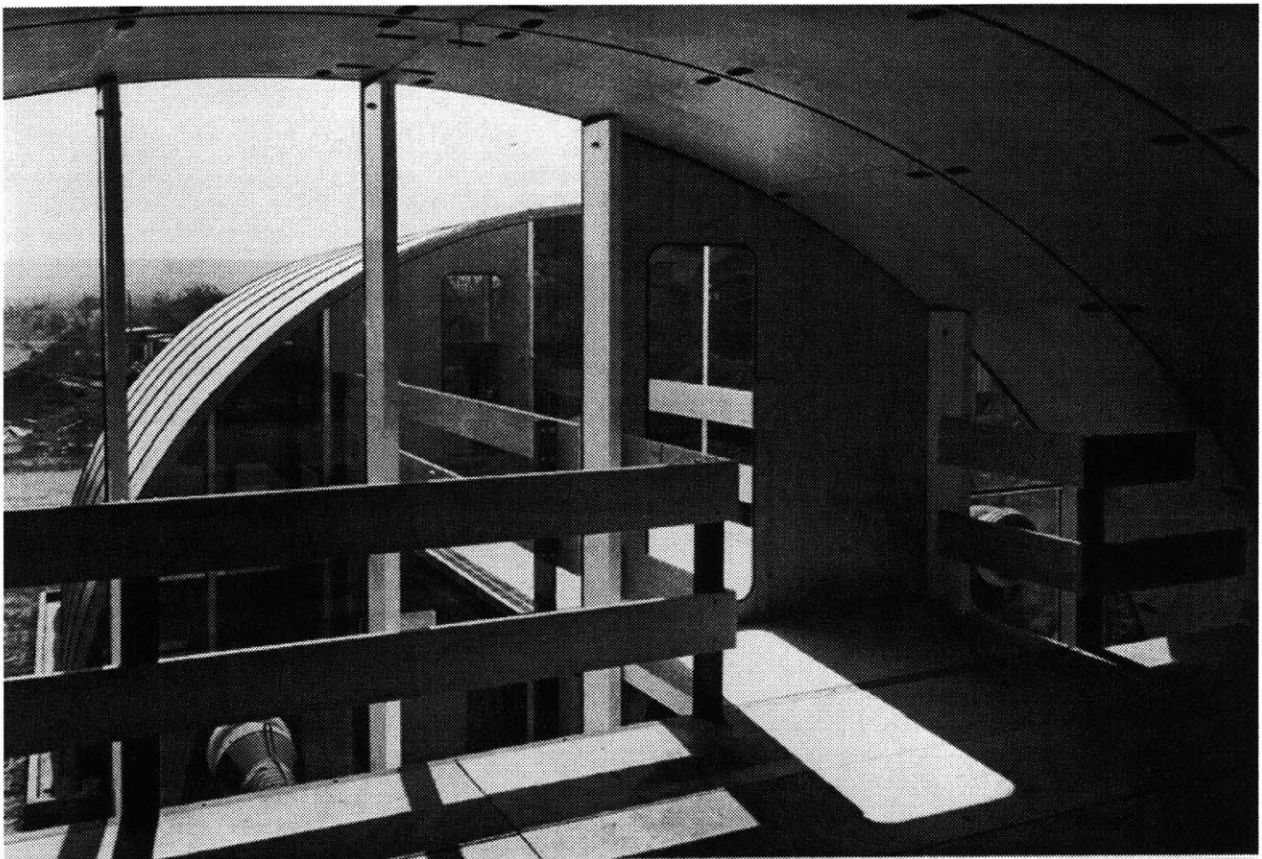

Figure 21.1 + 21.2. Youth Center, Paris, 1952, J. Prouvé



SYSTEM CATALOG physical assemblages

In order to begin to organize a construction sequentially, one must develop the phases involved in the building process. After consideration of the previous building references, the following phase was established:

1. Foundation Systems, which included all site preparation work and foundations.
2. Support Systems, the beginning of a vertical definition in the project
3. Frame Systems will regularize the support system and break it down into smaller sizes.
4. Floor Systems will provide immediate use terraces at all levels.
5. Roof Systems will begin to define the enclosed form and weather protection the building affords.
6. Screen Systems will supply the final arm's length habitable definition for most use applications.

This done, there are several traditions for categorizing building systems at work in the practice. Sweets catalog is the dominant system currently, supplying brochures directly from the manufacturer and dividing them into component categories.

FOUNDATION SYSTEMS:

Vane Foundation
Grade Beams.
Floating Slab.

SUPPORT SYSTEMS:

Precast Concrete Frame.
Folded Wall.
Territorial Plane.

FRAME SYSTEMS:

Vierendeel Truss.
Steel Bent.

FLOOR SYSTEMS:

Hollow Core Slab.
Bar Joist.

ROOF SYSTEMS:

Umbrella Roof.
Space Frame.
Truss Roof

ENCLOSURE SYSTEMS:

Smith Self-stable Screen.
Shotcrete Panel.
Extended Panel.

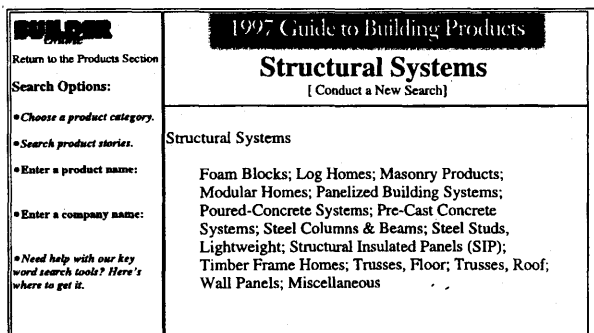

To the left is a newer manner of organizing the building systems. This webpage will give direct links to various manufacturers (subscribers). The systems are categorized by, I believe, the manufacturers themselves, and the results of those choices are not very useful to the builder wishing to keep options available and clear at all times.

Figure 23.

TECHNICAL DATA SHEET

grade beams

GENERAL:

Large beam running in the major direction rest on piles. These gain stability from crossing beams. The bottom of the cross beam is V-shaped to cut through moving earth in a frost upheave.

MATERIALS:

Precast piles and channel retaining walls. Sitecast grade beams with steel blades.

INSTALLATION:

Piles delivered to the site and driven through to bedrock, then topped with a in-situ concrete beam. Grade change is achieved with a precast concrete channel spanning vertically between cast in place beams, acting as a retaining wall and virtual formwork.

DIMENSIONS:

Pile	1' diameter; various lengths
Channel	8" x 8' slab, 1' x 2' beam various lengths
Grade Beam	3' wide x 5' deep; any length
Cross Beam	2' wide x 5' deep; up to 40' 3/8" thick blade

GROUNDLINE

PRECAST PILE

GRADE BEAM

PRECAST CHANNEL

CROSS BEAM

STEEL BLADE

BEDROCK

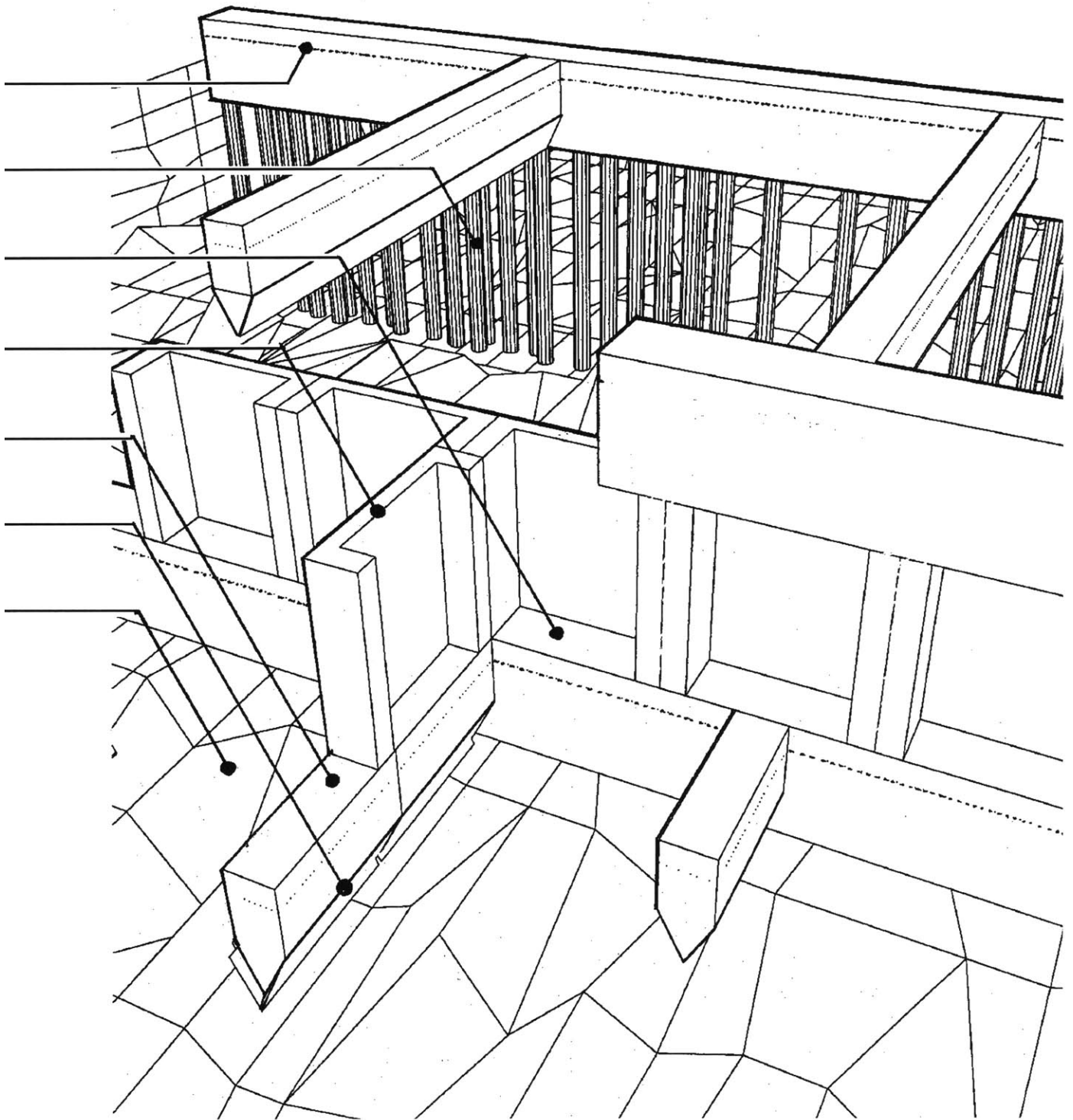

TECHNICAL DATA SHEET

floating slab

GENERAL:

The floating slab is cast in place, reinforced concrete. It distributes its load evenly over the soil, and contains the soil so it is not displaced. Deployed in 20' widths they have 2'+ gaps between for services and access.

MATERIALS:

Cast in place concrete sitting on a bed of gravel. The formwork is reusable and made from wooden panels.

INSTALLATION:

The area for the slab is excavated and shored up. The formwork is set and a bed of gravel dumped between the bays. Steel is then placed directly over the gravel and the concrete is delivered to the site.

DIMENSIONS:

Slab	12" deep; 20' wide; 48' long
Beam	2' wide x 5' deep.

RETAINING WALL

SLAB

SHRINKAGE STEEL

REINFORCING STEEL

GRAVEL

WOOD FORMWORK

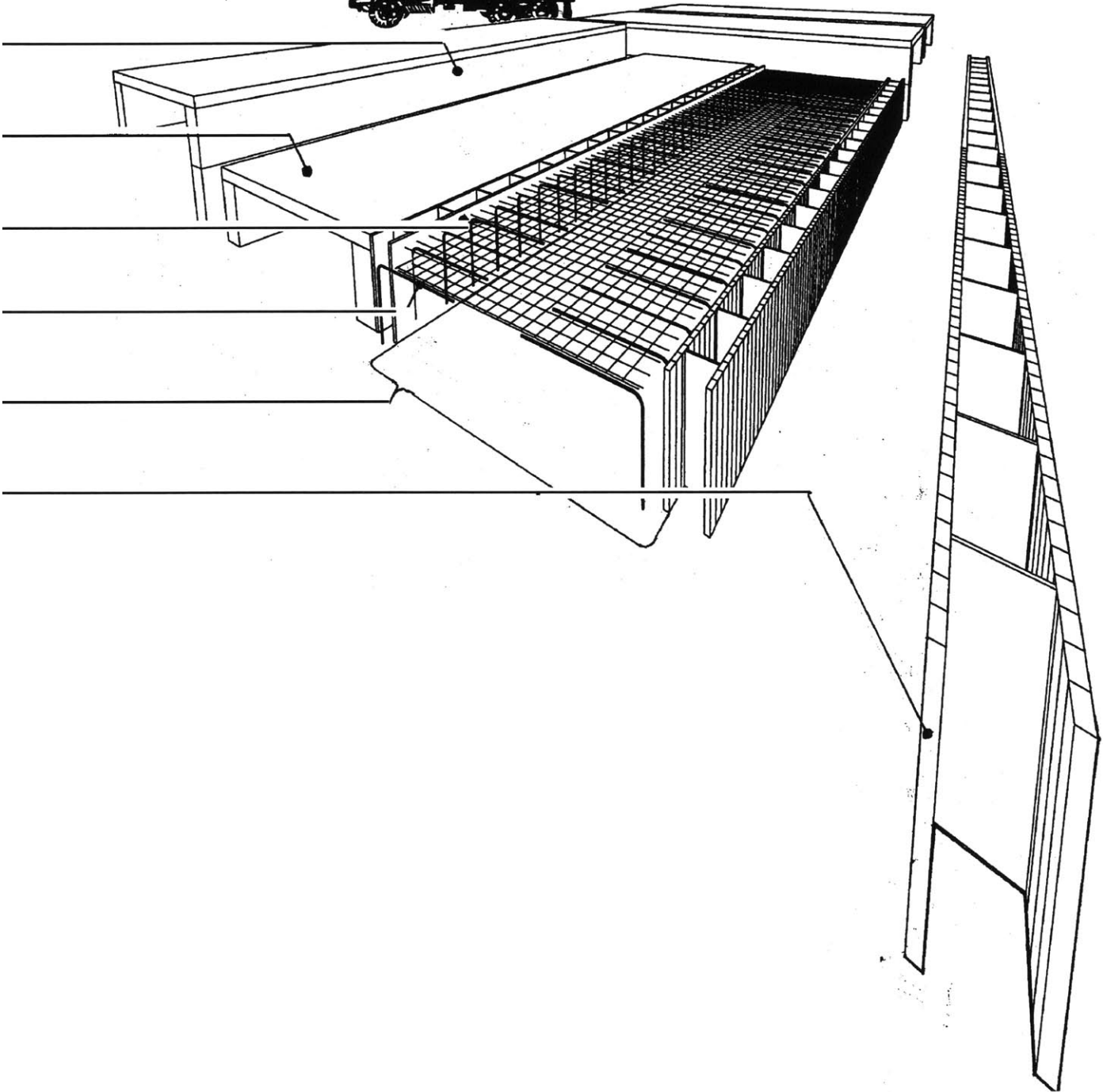

TECHNICAL DATA SHEET

vane foundation

GENERAL:

Vanes are precast concrete columns set into cast in place concrete foundation footings. A Beam branches off from the vane creating a vertical and three dimensional foundation support. The ground surrounding the vane can be operated on independently from the assembly and can be either left as exposed earth or covered with floor element options.

MATERIALS:

The footing is cast in place concrete, which may come up beyond ground level. The vane and the beam are precast prestressed concrete and are available in a variety of options.

INSTALLATION:

Excavation as required for the soil conditions takes place first, followed by the concrete footing with imbedded plates for the precast vanes. The vanes are positioned by crane and bolted into place. The beams are then attached to the vanes, and the entire assembly is complete.

DIMENSIONS:

Footing:	6' x 8' pad, varying depth
Vane	1' thick; 8' wide; 24' tall
Beam	1' wide x 4' deep; 24' long

BEAM CAP

VANE

FOOT

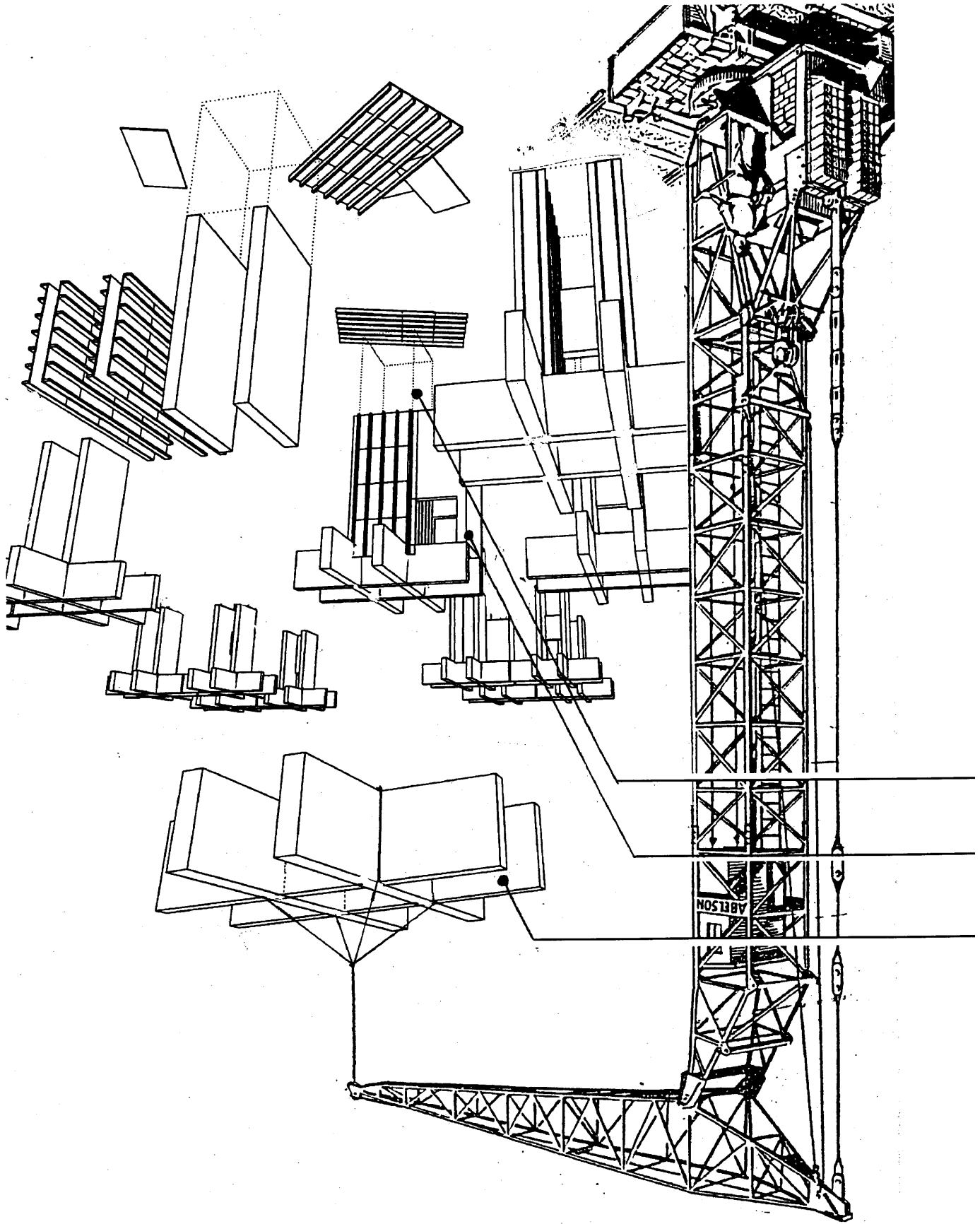

TECHNICAL DATA SHEET

precast concrete frame

GENERAL:

The floating slab is cast in place, reinforced concrete. It distributes its load evenly over the soil, and contains the soil so it is not displaced. Deployed in 20' widths they have 2'+ gaps between for services and access.

MATERIALS:

Cast in place concrete sitting on a bed of gravel. The formwork is reusable and made from wooden panels.

INSTALLATION:

The area for the slab is excavated and shored up. The formwork is set and a bed of gravel dumped between the bays. Steel is then placed directly over the gravel and the concrete is delivered to the site.

DIMENSIONS:

Double T 4' Wide, 2' deep;
spanning up to 40'
rising 3 floors without bracing

NOTES:

This building system was used in Imre Halasz's Design Studio at M.I.T. in the Spring of 1996, as shown in figure 30.

COLUMN ASSEMBLY

WALL ASSEMBLY

CHANNEL BEAM

FLOOR ASSEMBLY

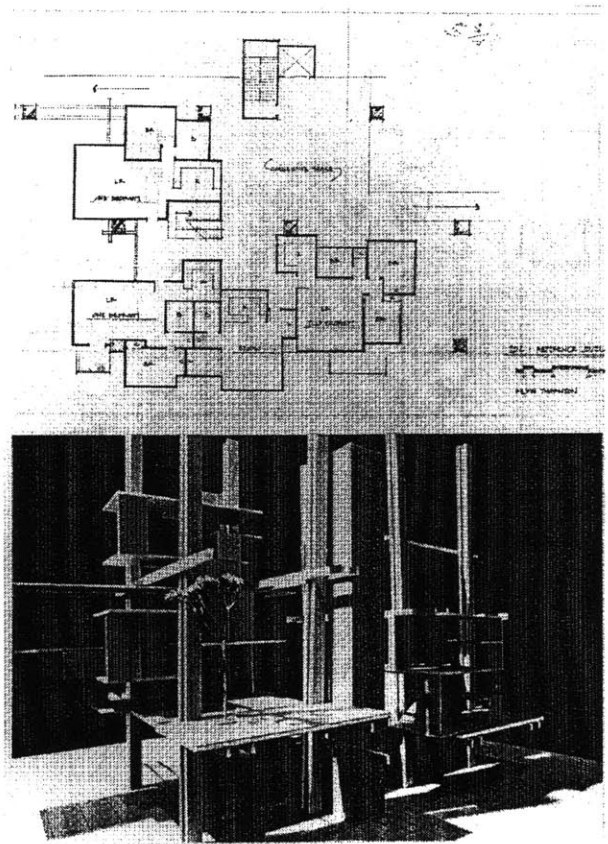
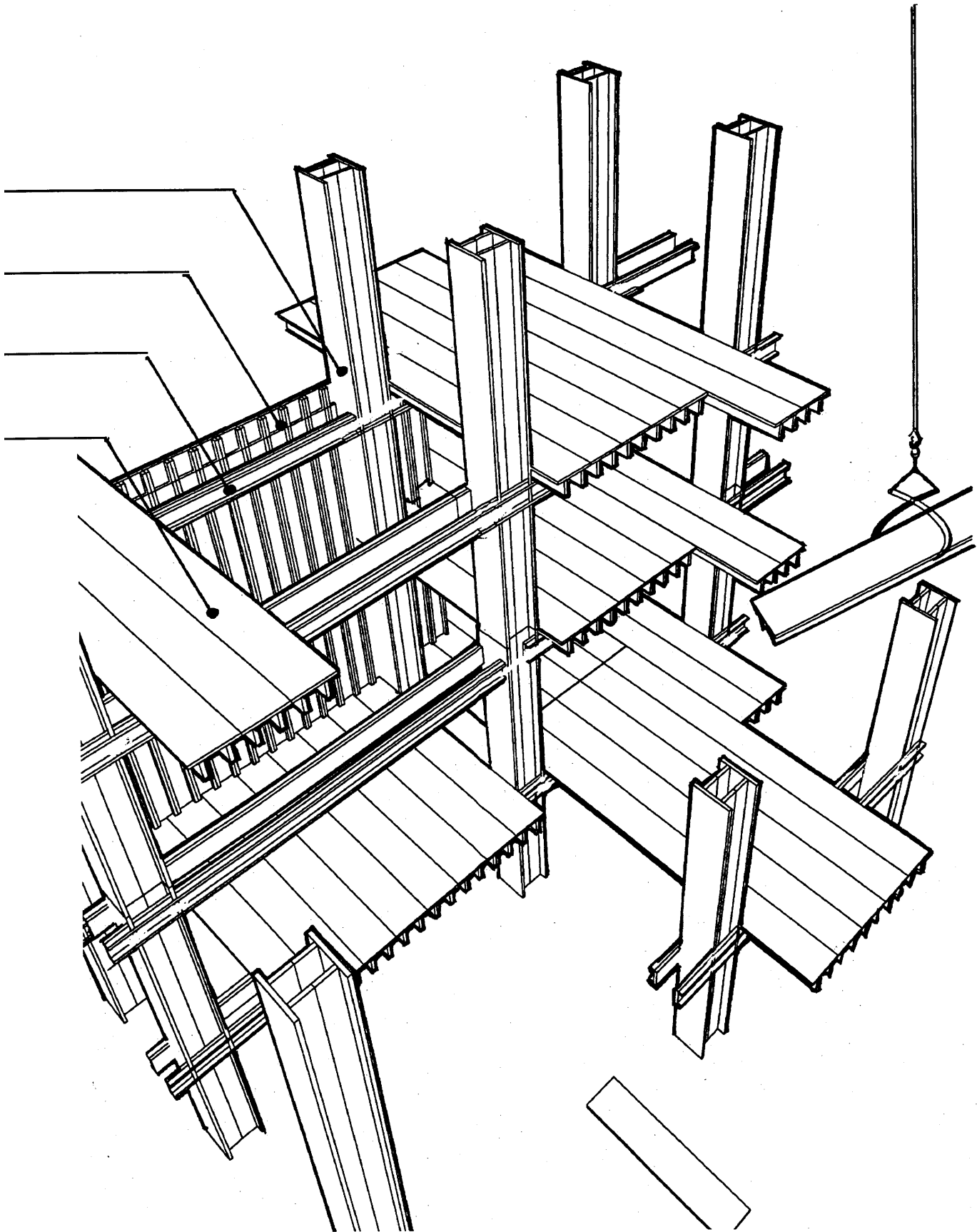

Figure 30.



TECHNICAL DATA SHEET

folded wall

GENERAL:

A continuous surface built of prefabricated panels and beams. Deployed in pairs for stability and stabilized with crossing beams. The walls may have openings in them, and cantilever is possible.

MATERIALS:

Panels come in various sizes, and are precast and prestressed concrete. Weld plates of steel edge each corner of the panels, and each panel is pierced for ease of movement and fabrication.

INSTALLATION:

Delivered to the site, the panels are placed by crane into position. They are then welded in to position in the field. The panels are alternated with beams to build vertical spacing and to bridge the seams. The entire assembly is then rodded and grouted through regular spaced holes.

DIMENSIONS:

Panels	1' thick x 4' deep; 8', 12', 16' and 36' lengths
Beams	1' x 1' in the lengths above

PANEL

BEAM

WELD PLATE

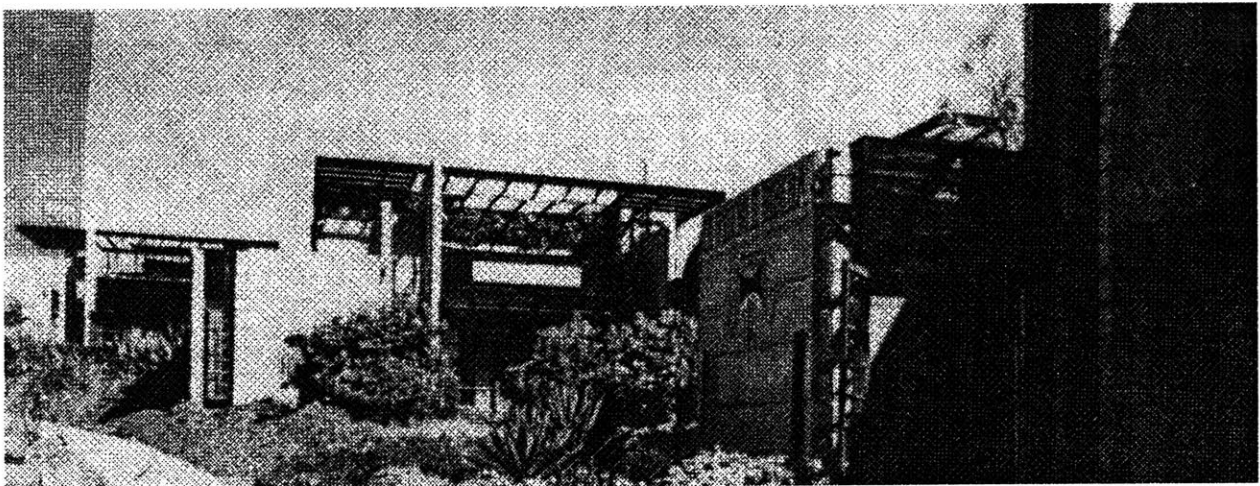
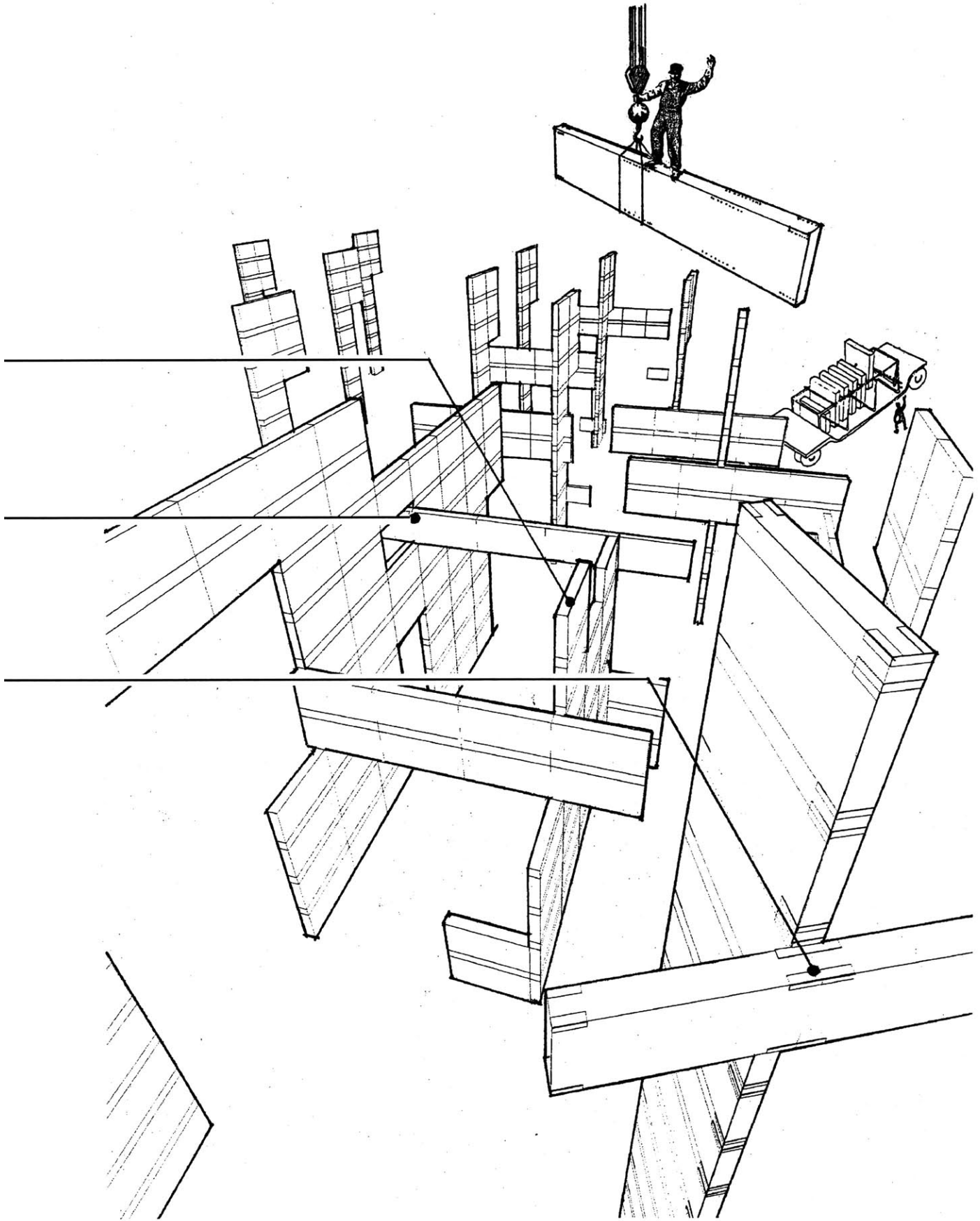

Figure 32. Pueblo Ribera, R. M. Schindler



TECHNICAL DATA SHEET

territorial plane

GENERAL:

A steel frame gathering its rigidity from bolted connections of triangulated members. Lateral stability is achieved through roof purlins and diagonal cable bracing. Typical of warehouse construction, steel bent buildings are quickly erected.

MATERIALS

Cast in place concrete, using an integrated reinforcing/ reusable formwork system (see below).

INSTALLATION:

Erected atop a foundation, the

DIMENSIONS

Bents	1' W sections; 20' high [tallest]; 40' span [greatest]
Purlins	1/4" folded plate steel; 6" wide X 8" tall
Bays	12' wide, 8' slack.

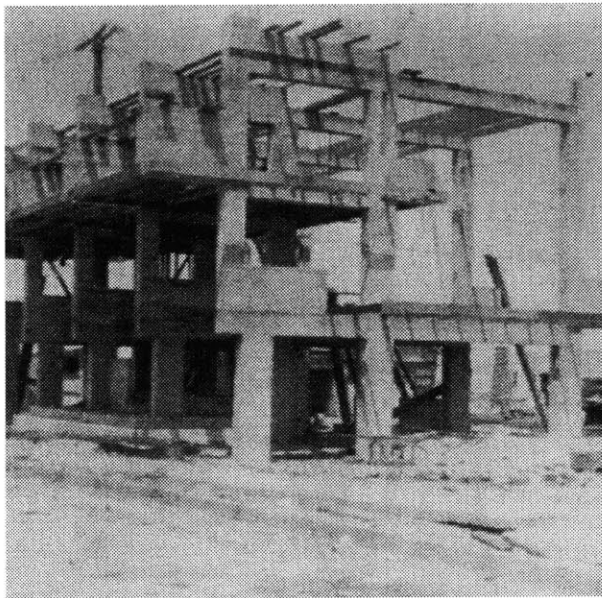

Figure 34.1. Lovell Beach House, R.M. Schindler

PURLIN

WIDE FLANGE

CABLE

CROSS MEMBER

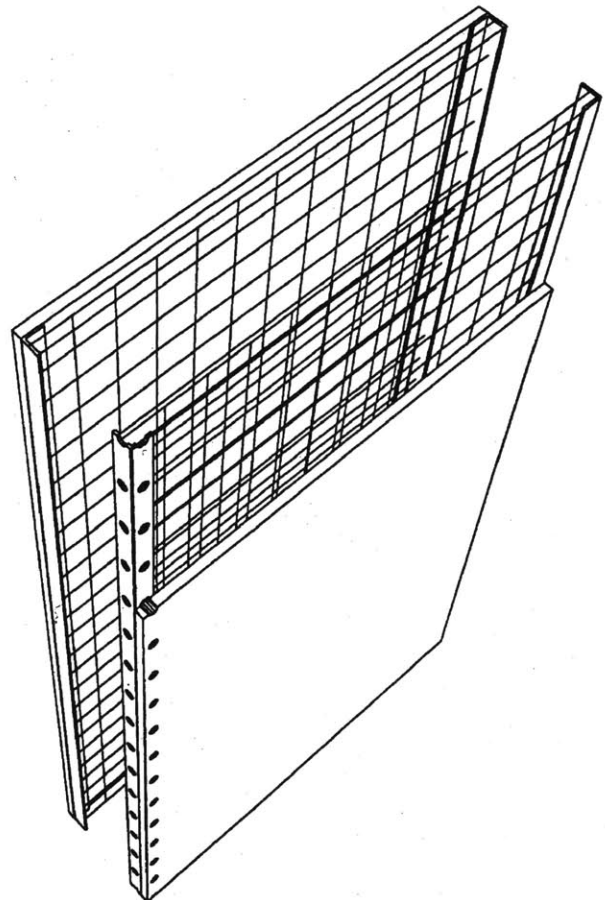
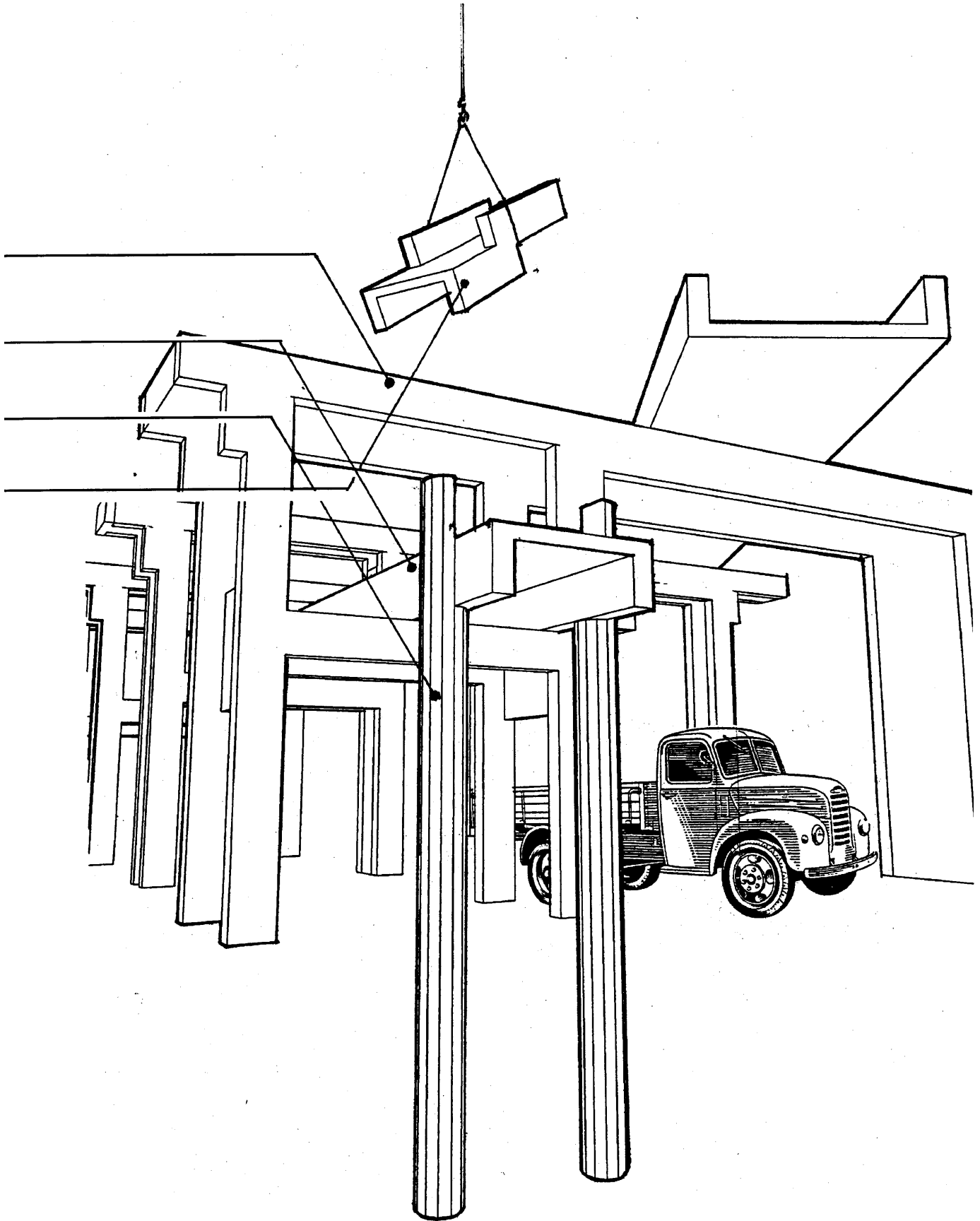

Figure 34.2 Integral formwork and reinforcing.



TECHNICAL DATA SHEET vierendeel truss

GENERAL:

The vierendeel truss has no diagonal members, allowing for door openings and throughout the span of it. Supported from either the top or bottom chord, it is capable of taking up the vertical slack exchange between two different systems.

MATERIALS:

Made of steel tubs sections, the chords of the trusses are added together to form a U section. This U then sandwiches the vertical struts which are welded in place. The trusses are propped up with similarly dimensioned tube sections, paired together and spaced to sandwich around the truss.

INSTALLATION

Vierendeels are prefabricated and placed with a crane. The trusses are deployed in pairs or singly, and field welded to each other.

DIMENSIONS:

Truss	4"X12" chords + struts; 4"X4" spacers; lengths up to 60'; depths up to 8'
Column	4"X12" members; 4"X12" spacers, heights up to 40'

TRUSS ASSEMBLY

COLUMN ASSEMBLY

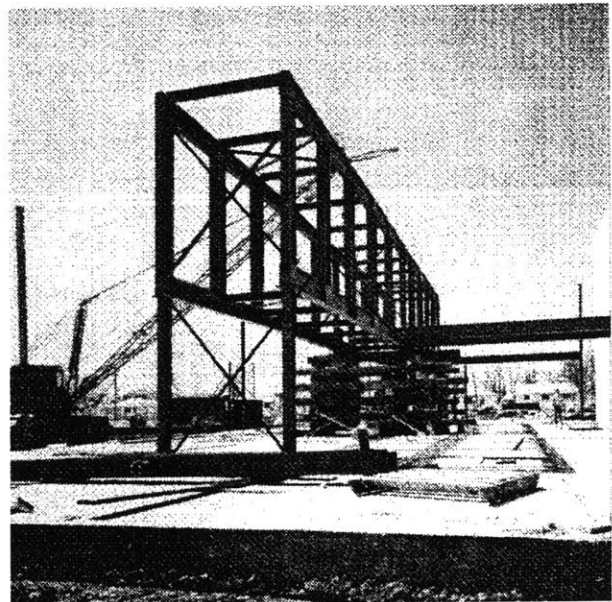
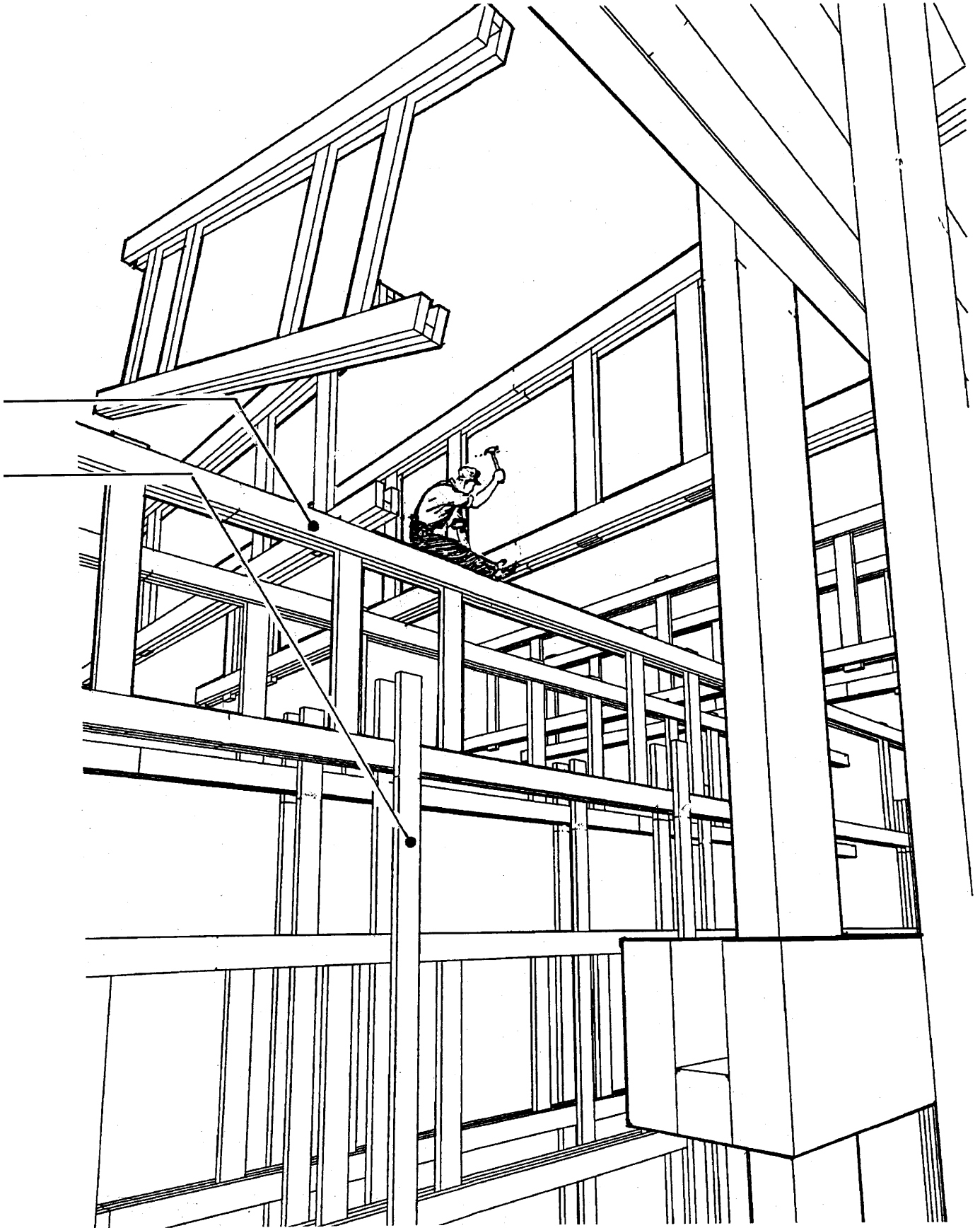

Figure 36. High School Addition, Dominion Bridge Co.



TECHNICAL DATA SHEET

steel bent

GENERAL:

A steel frame gathering its rigidity from bolted connections of triangulated members. Lateral stability is achieved through roof purlins and diagonal cable bracing. Typical of warehouse construction, steel bent buildings are quickly erected.

MATERIALS:

Wide-flange steel sections make up the primary definition, and folded steel plate purlins run counter to that direction, and high strength steel cables are the final element.

INSTALLATION:

Bents are prefabricated and placed with a crane. The bents are deployed in bays, field bolted across the short direction. These bays are in turn stayed by cables and continuous purlins and sheathing.

DIMENSIONS:

Bents	1' W sections; 20' high [tallest]; 40' span [greatest]
Purlins	1/4" folded plate steel; 6" wide X 8" tall
Bays	12' wide, 8' slack

PURLIN

WIDE FLANGE

CABLE

CROSS MEMBER

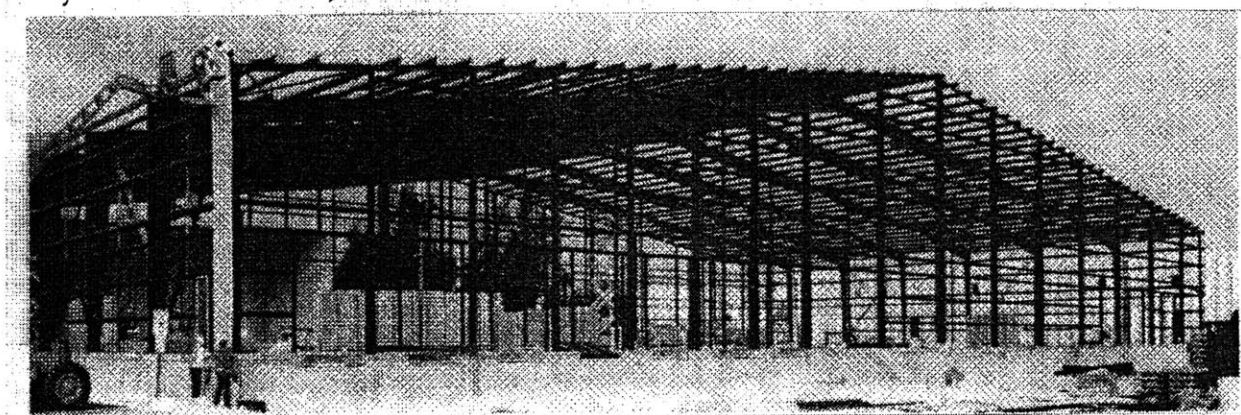
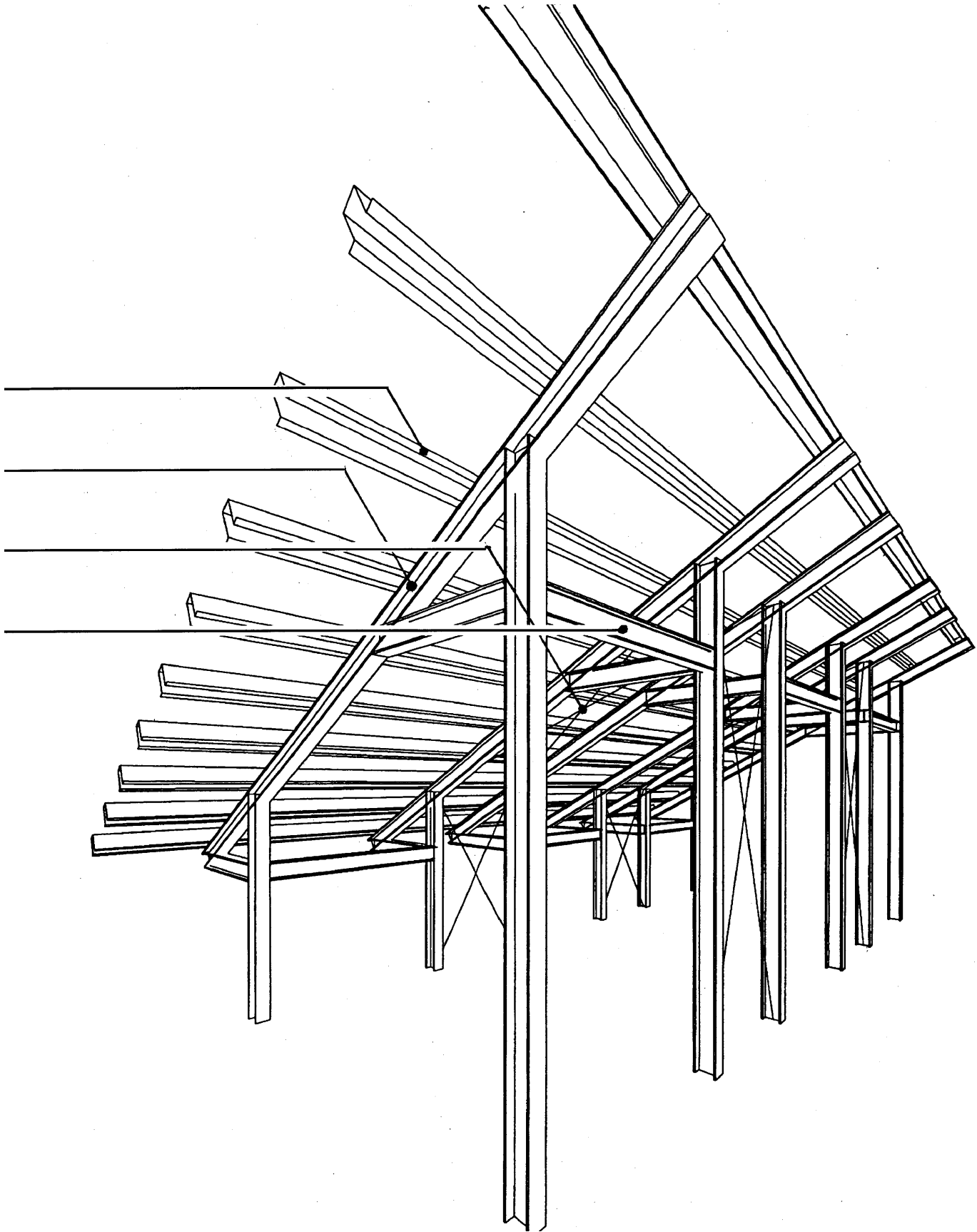

Figure 38. Dean Steel Buildings, Inc..



TECHNICAL DATA SHEET hollow core slab

GENERAL:

Floor slab element with a fire resistance of three hours.

MATERIALS:

The floor assembly is made of precast prestressed concrete slabs with a sitecast concrete topping and steel decking which can span between the slabs to allow floor penetration.

INSTALLATION:

Delivered to the site on flatbed trucks and then hoisted into position by a crane. The topcoat is cast on site after the floors are set and the openings roughed out.

DIMENSIONS:

Slab	4' widths; 6" deep; spanning up to 32'; maximum cantilever 2'.
Steel Deck	3" corrugation spanning 4'

HOLLOW CORE SLAB

TOP COAT

STEEL DECK

SUPPORT

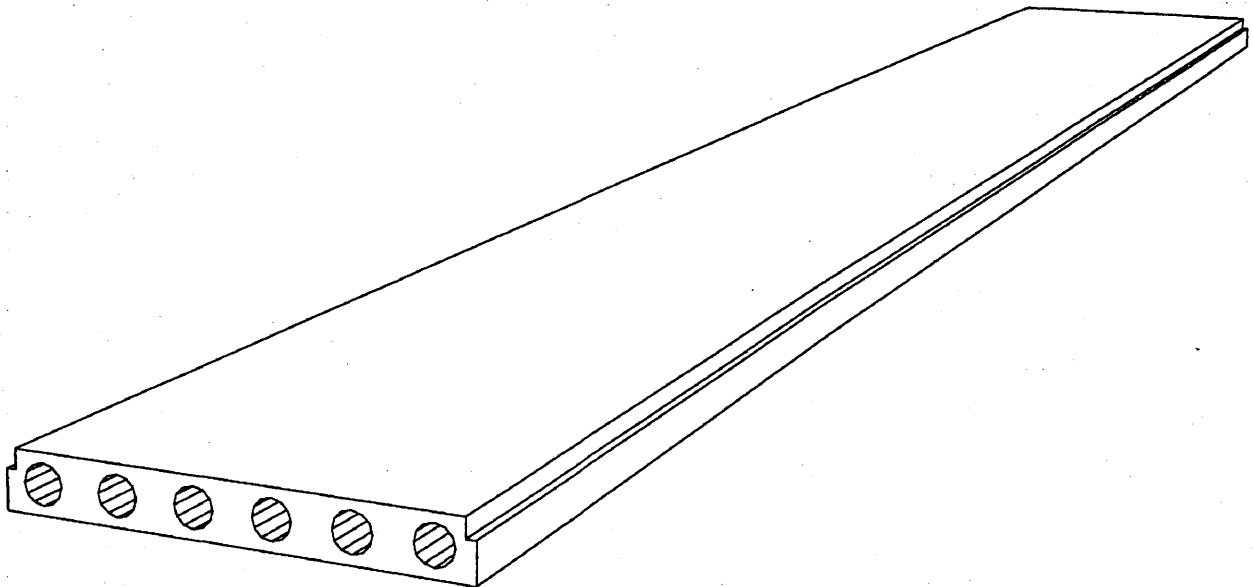
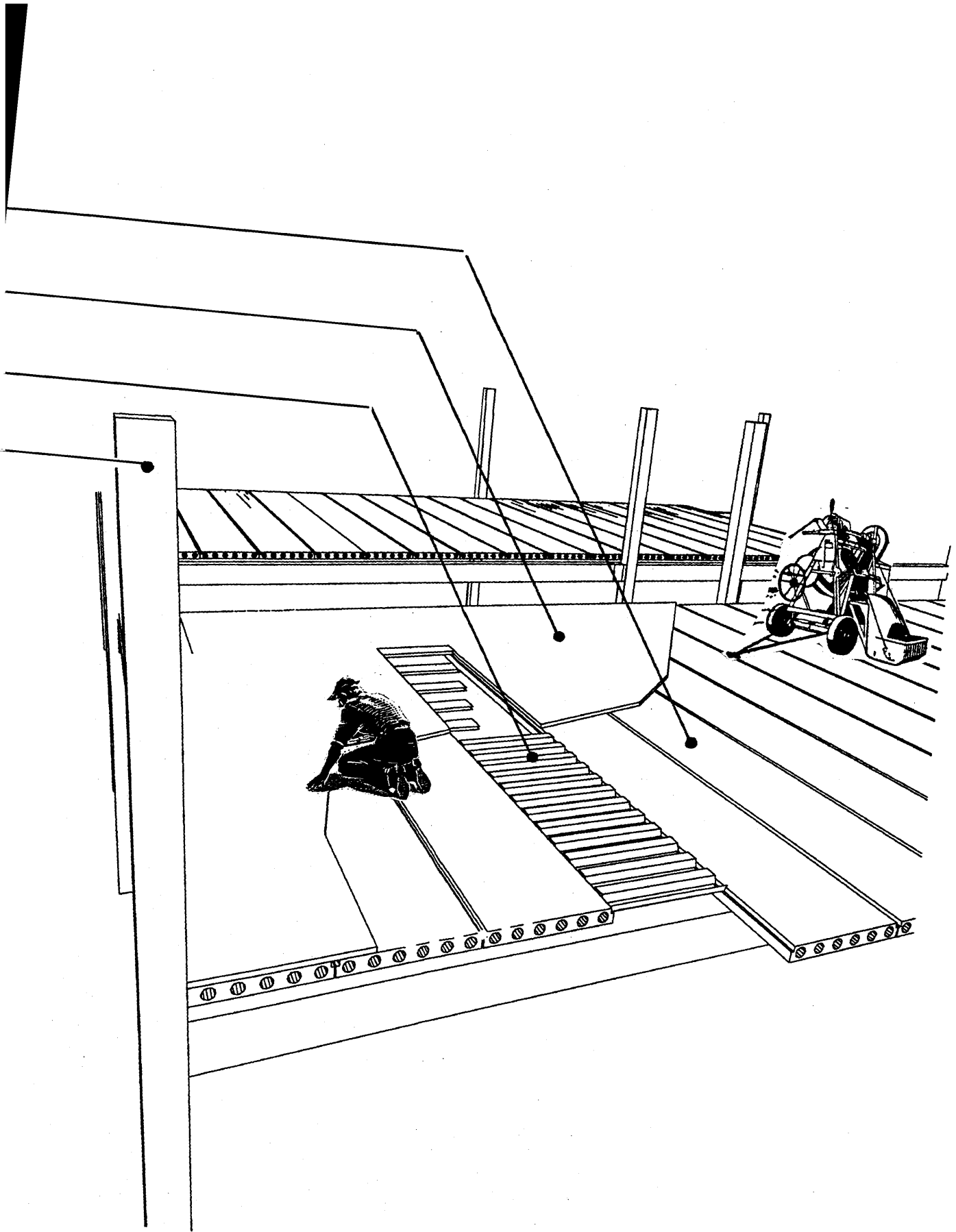

Figure 40. Hollow Core Slab Plank



TECHNICAL DATA SHEET

bar joist

GENERAL:

A lightweight floor truss element acting as either a floor or roof. Supported on either end, cantilever is allowed by the transformation of the open web to a solid transfer plate.

MATERIALS:

This open web steel joist is comprised of double angle sectioned top and bottom chords welded to a continuous folded steel rod. Steel bridging and corrugated decking provide lateral support. A top coat of concrete adds to the overall strength and provides a finished floor surface.

INSTALLATION:

Prefabricated and delivered to the site, the bar joists are anchored to the supporting members and bridged across. Openings are framed with channel sections supported by adjacent joists, and the interrupted bar joists rest on those headers, as in conventional framing techniques. The assembly is sheathed with decking and given a coat of concrete.

DIMENSIONS:

Bar Joist	20" deep, 32' span; set at 3' edge to edge
Deck	3" deep [corrugation; 4' x 12' panels
Top Coat	2" deep sitecast concrete

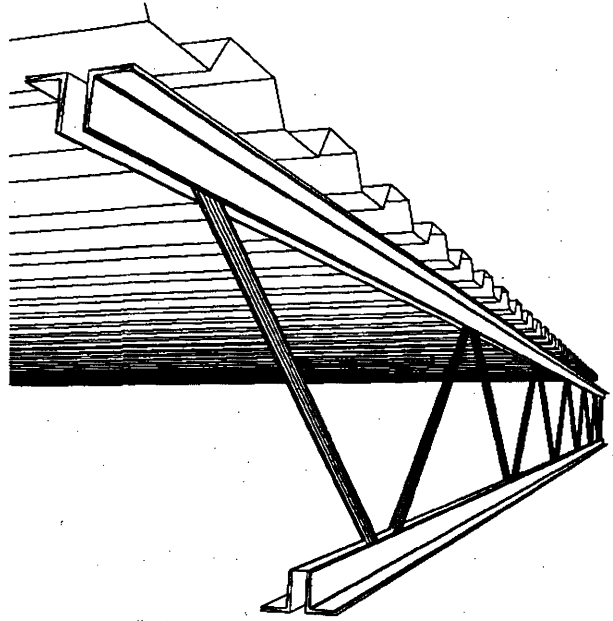

BAR JOIST

TOP COAT

TRANSFER PLATE

STEEL DECKING

BRIDGING

CHANNEL HEADER

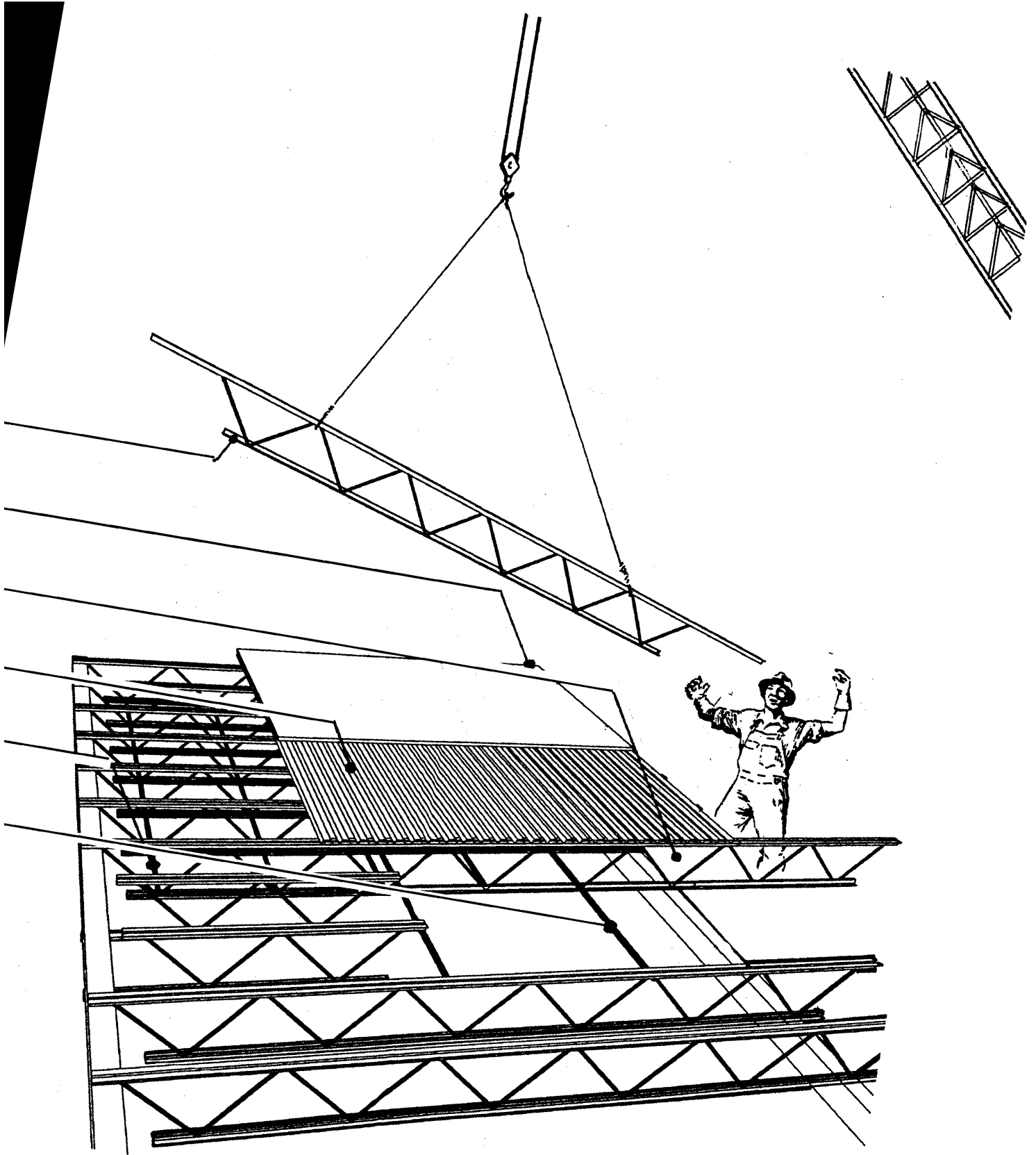

TECHNICAL DATA SHEET

umbrella roof

GENERAL:

The umbrella roof is a derivative of a tree structure. The cellular and lightweight nature of the system make it ideal for outdoor coverings, working well both in rain and bright sunlight. Varying the size and offsetting the cells allows for different arrangements of the roof, either with openings, or adding up to a larger-sized assembly.

MATERIALS:

Columns are steel pipe sections, and the structure of the cell is comprised of wood members with steel ties. The roof membrane is polypropylene, a woven, weather resistant material which can come in a variety of colors. Vierendeel trusses are made of wood with steel straps.

INSTALLATION:

Pipes are placed on footings, and temporarily shored up while the wooden cell is lifted in and hung. The cells are then strapped together for stability. Vierendeel trusses act as a continuous linear transfer, and allow for horizontal displacement as well.

DIMENSIONS:

Cell A	20' bay; 2x10 members
Cell B	16' bay; 2x10 members
Cell C	12' bay; 2x10 members
Column	8" diameter
	varying lengths up to 40'
Vierendeel	5' deep; 2x10 members

REFERENCE:

Handloom Pavilion- Delhi, Correa, 1958

ROOF MEMBRANE

VIERENDEEL TRUSS

WOODEN CELL

STEEL PIPE



Figure 44. Handloom Pavilion - Delhi - C. Correa

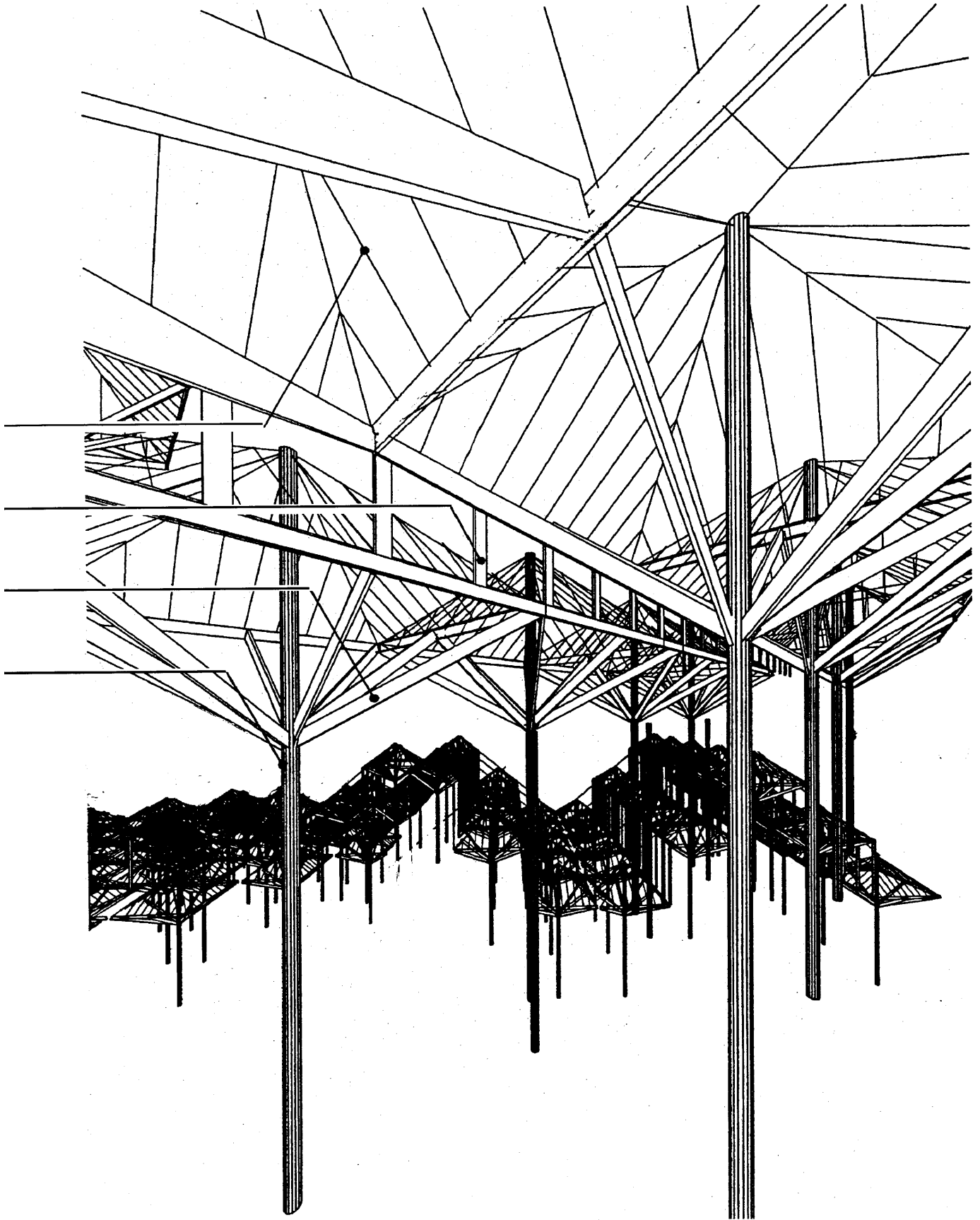

TECHNICAL DATA SHEET

space frame

GENERAL:

A lightweight and inherently rigid structure, the space frame is capable of large spans and is highly compatible with building services and utilities. The system is classified as noncombustible construction, and may be exposed when 20' above the floor. The module is a skewed offset equilateral triangle,

MATERIALS:

Steel Unistrut© members act

INSTALLATION:

Large modules are fabricated in the shop and transferred to the site. The roof is then assembled on the ground, and lifted in to place by crane. This reduces in-place and field connections to a minimum.

DIMENSIONS:

Unistrut2" square section;

lengths up to 5'

Gusset

1/4" plate metal;

8" diameter, folded

Assembly

spans up to 60' for 3' depth

UNISTRUT© CHORDS

GUSSET PLATE

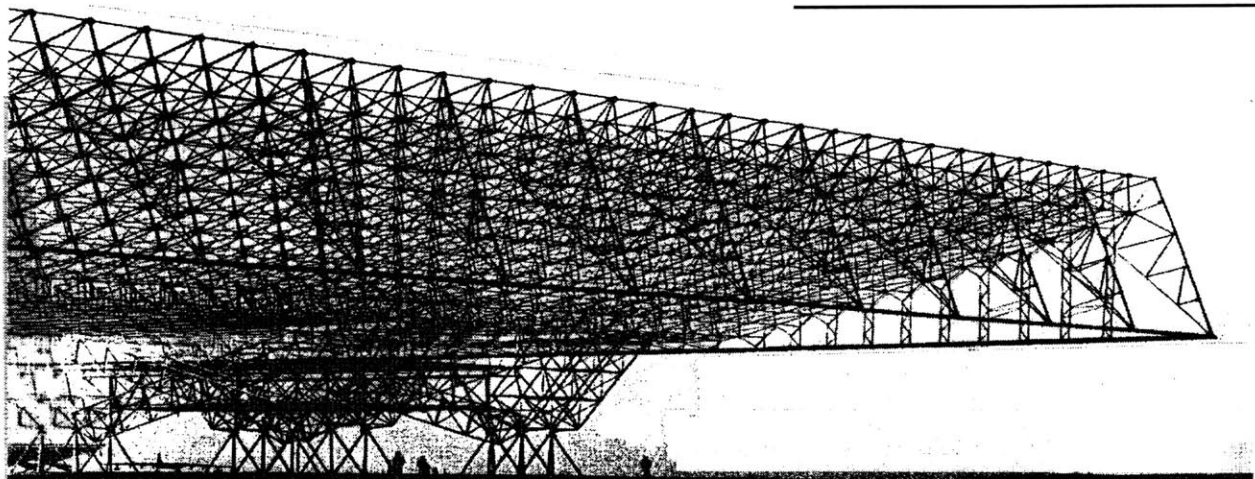
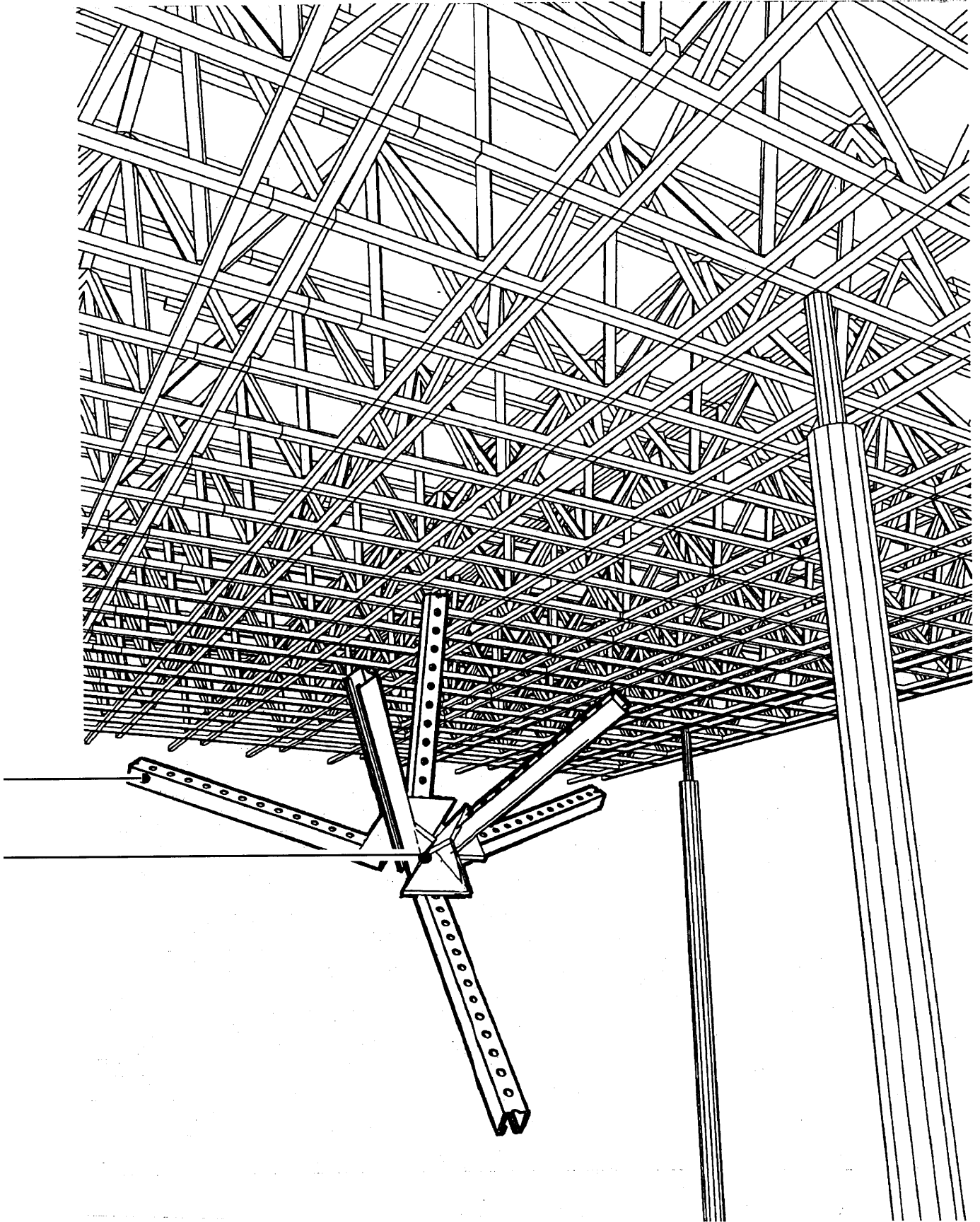

Figure 46. Project for US Air force Hangar, K. Wachsman, 1950.



TECHNICAL DATA SHEET

smith self-stable screen

GENERAL:

This screen is a revised generic 'platform' frame system.

MATERIALS:

Each screen is 2"x6" studded at 2', 3' and slack. Studs are let into plates which are 'beamed' by second plate face lagged at screen heads and feet. Studs are 'dwanged' at half height to reduce vertical unrestrained cantilever. Each screen is therefore able to receive loads from the subsequent action anywhere along its length, free from 'setting out' or material center lines, etc.

Such 'earned' territory offers many options for positioning shear panels, glazings, secondary screens, etc. [-from the Comic Book- MKS]

INSTALLATION:

Screens are similarly "T" restrained at junctions: affording light at the corner, and maximal openness at bay returns. Screens are prefabricated to order in the shop, and are delivered to the site, glazed and insulated.

DIMENSIONS:

Members: 2"x6" wood studs;
 lengths up to 16'
Assemblies: 8'x[4', 12', 16']

REFERENCE:

STUD

"T" RESTRAINT

DWANG

FACE PLATE

PLATE

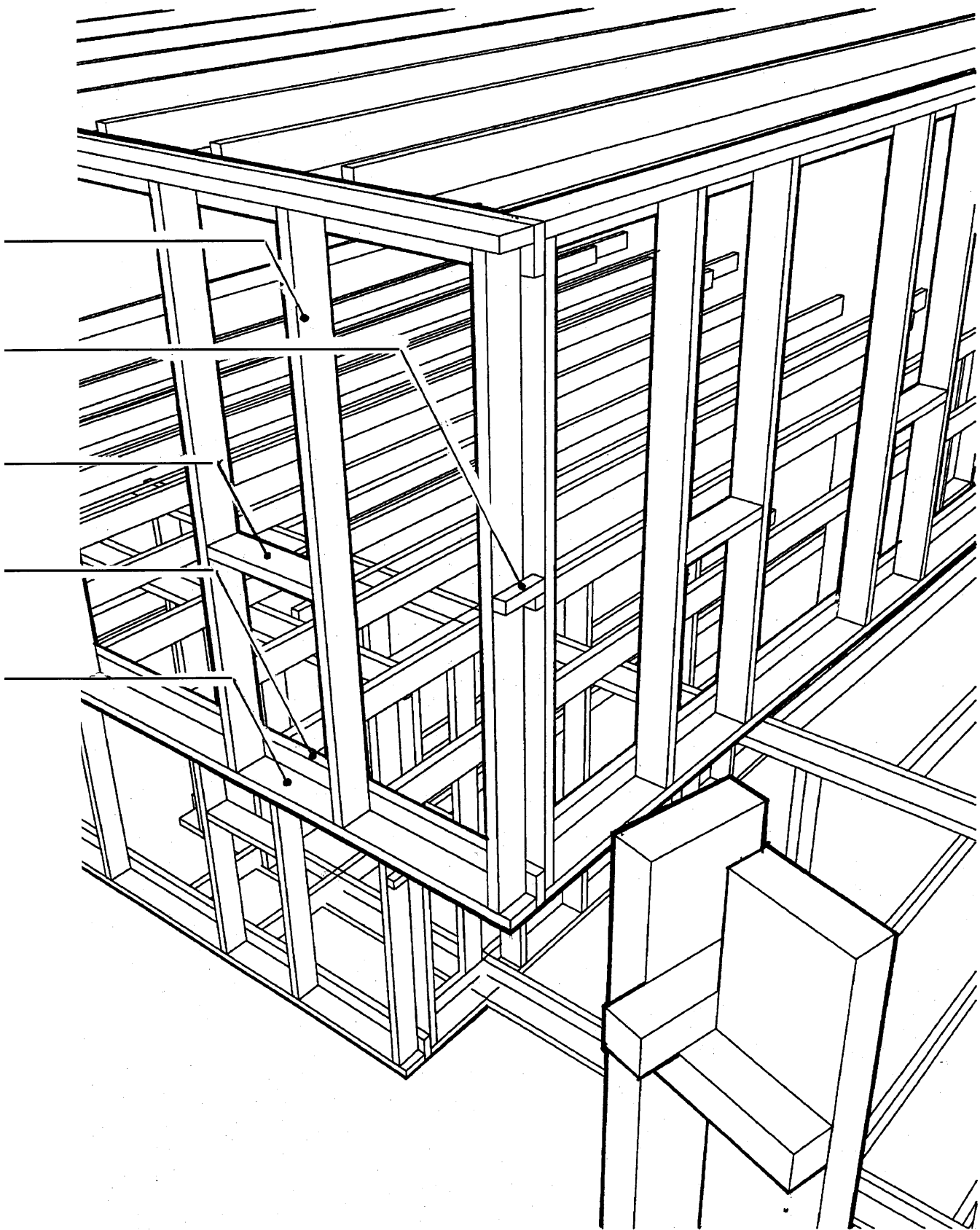

TECHNICAL DATA SHEET

shotcrete panel

GENERAL:

The shop-fabricated panels consist of welded wire trusses and a foam plastic core to which field-applied plaster is placed on each side. An insulated foam/ integral formwork building panel system capable of acting as wall, floor, roof, or spandrel beam.

MATERIALS:

Polystyrene core and galvanized steel trusses, fabricated in the factory with site applied shotcrete or plaster.

INSTALLATION:

Panels are delivered to the site by a light truck. Since they are easily moved by a single worker, they are erected and cut to size quickly. After the floor's worth is assembled, the gunnite crew comes in and sprays.

DIMENSIONS:

Foam	2.5" thick
Shotcrete	2" thick
Total Wall	6.5" thick
Panel	4' wide; 6' - 14' tall

INSULATING FOAM

MESH REINFORCING

SHOTCRETE

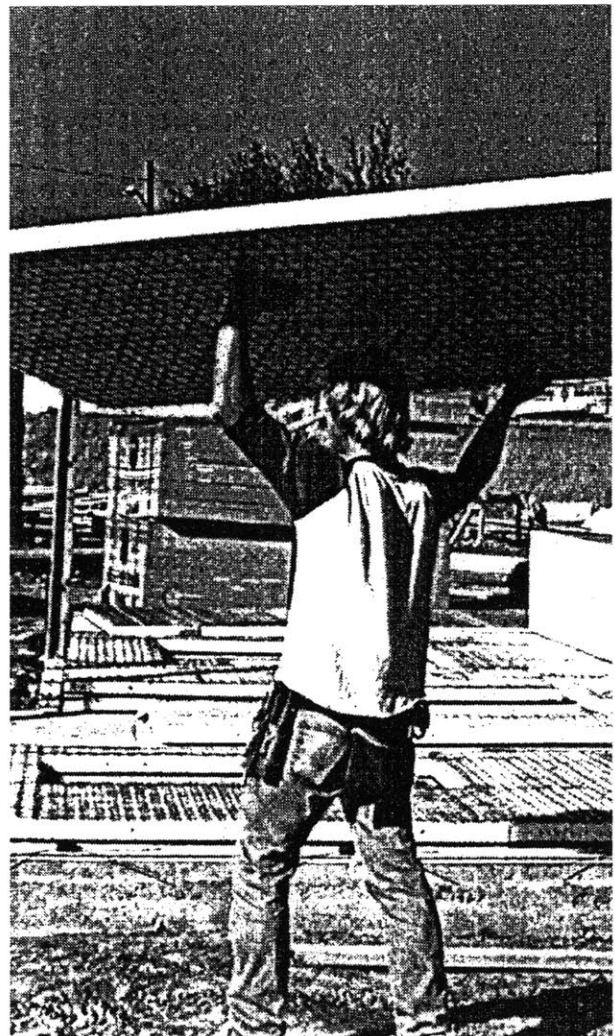
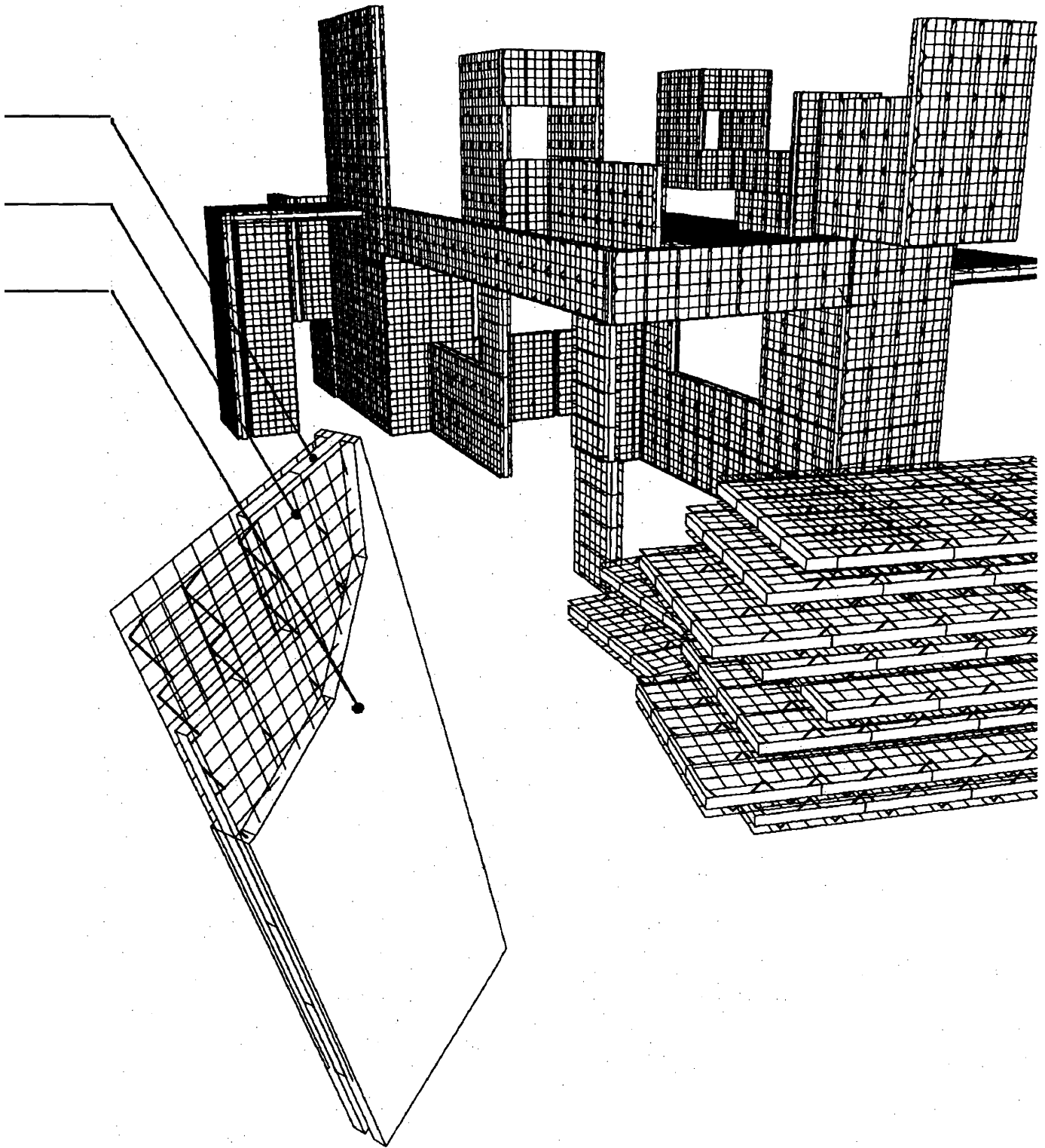

Figure 50. Covintec's Therm-Impac™ Panel.



TECHNICAL DATA SHEET **extended panel**

GENERAL:

Prefabricated wood stud panel assemblies which may act as roof, floor, enclosure, screen and stair. The panels are self stable when deployed in pairs, which allows for lateral displacements independent of the total form.

MATERIALS:

Panels are built of wood members- studs and plywood-in their nominal dimensions. Panels are built in the factory with glazing, insulation, and weather protection. Additional materials compatible to this system are glazing, metal sheathing, and glass block.

INSTALLATION:

Prefabricated and stocked in a warehouse, the panels are delivered to the site on a flatbed truck. Panel erection can take place with a small crew and a block and tackle. Slack between panels can be filled in with glass block spacers and caulked. The additional height of the glass block allows it to be flush to finish surface intensification.

DIMENSIONS:

Panels 8' wide, 8',12',16' or 20' long;
 1/2" plywood;
 2" x 6" wood studs

REFERENCE:

Panel Assemblage for Housing:
Some Form and Construction Explorations for
Small Buildings.

David Borenstein, M. Arch. Thesis, M.I.T. 1984

EXTENDED PANEL

SCREEN PANEL

ROOF PANEL

FLOOR PANEL

LIGHT CONNECTION

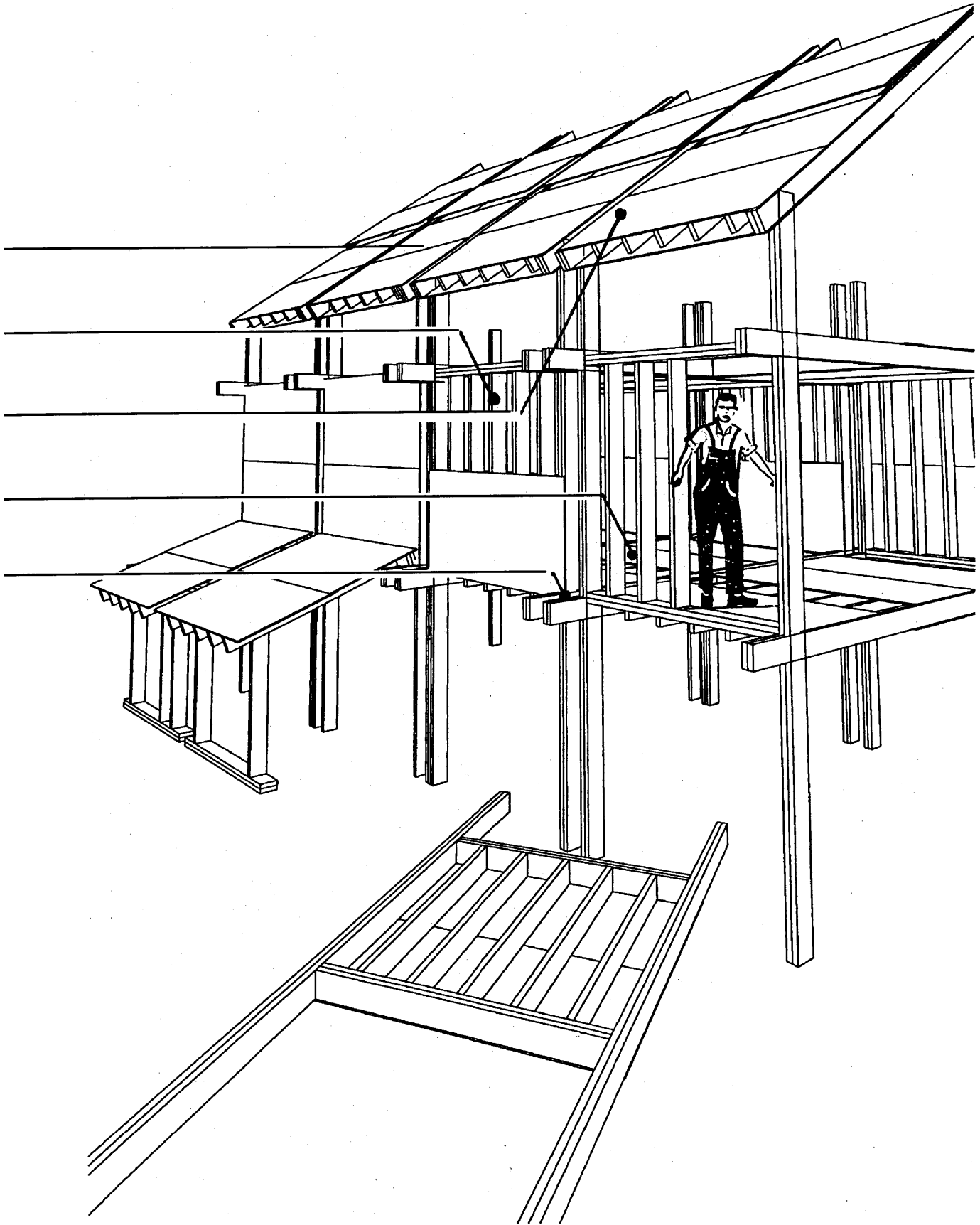

PARALLEL SYSTEMS INVESTIGATION

Now that the physical systems have been categorized and cataloged, one can begin to deploy them, or put them to work. The attitude behind this exercise is threefold.

The first is to explore the intrinsic attributes of the system in specific, as opposed to the generic descriptions cataloged. This specific, or built, deployment will necessarily address issues of use, site, and so on. This will be addressed more fully in the next section on site and program. The second is to compare the options at each phase against each other and the various combinations of the different systems. The third task is to discover the means of exchange between the systems. This final lesson will yield the most convincing evidence as to the benefits that direct, sequential system assemblage has to offer.

In order to achieve this parallel approach, decisions would have to be phased independently of and parallel to each other. This is discussed further in Appendix 1 in the original thesis proposal submission. In that proposal is a diagram about the phased decisions. The branching behavior of the chart traces the decision tree that lead to each conclusion, or result. This would then allow the results to be compared and contrasted. This section of the thesis explores one partial system assemblage, illustrated here in a phased manner.

The designer brings the formal order to the elements involved in the project. This organizing system is much the same as any other system: the more open it is, the more options are available. It has rules, logic, and once set in place will generate possibilities. One potential exercise (*see Appendix 1*) could be to include these formal systems as phases in the assemblage, which could then be evaluated to see how they impact the project in the end as well as during the design phase.

The following chart traces this basic behavior:

PROJECTIONS

alternatives	A	B	C	D	E
decisions	*		*	*	
designs (3)	A		C	D	
alternatives	1	2	3	4	5
decisions		*		*	*
designs (9)		A2/C2 D2		A4/C4 D4	A5/C5 D5
alternatives	a	b	c	d	e
decisions	*	*	*		
designs (27)	A2a/A4a A2b/A4b A2c/A4c D2a/D4a D2b/D4b D2c/D4c	A2b/A4b A2c/A4c A2d/A4d D2b/D4b D2c/D4c D2d/D4d	A2c/A4c A2d/A4d A2e/A4e D2c/D4c D2d/D4d D2e/D4e		

PROJECT

The second course of the thesis will be an application of this methodology to an architectural project. The design process will be both artificially accelerated and hampered by strict scheduling and unexpected contingencies. Here, the various alternatives will be selected and played against the forces of the site and program (contingencies) and at later times in the development of the building pursued parallel to each other.

The site is located on the edge of Honolulu's downtown, where the city begins to transform into an industrial area [surprisingly close to a residential neighborhood].

The program will be for a mixed use of retail, office, and residential. The exact amount of each will be variably assigned during the course of the project, but I anticipate the total of approximately 75,000 square feet.

Scheduling will be phased to simulate the actual construction of the project (accelerated to meet the pace and

Figure 54. Thesis proposal.

SITE + PROGRAM

It's a small world (*see figure 55.1*), and technology is shrinking it every day. The same means which allow us to make these building systems also allow us to move them virtually anywhere on the planet. The attitude of this thesis is that building is taking place all over the world, and this method can be part of all of it. In order to focus on the deployment of the systems, a site had to be chosen which would specifically not interfere. It had to be urban - to deal with the densities involved, and to provide necessary siteline constraints. It also had to be consistent in order to test the systems in a controlled manner. The site chosen was the 45th parallel north, plus or minus.

This could include cities such as Seattle, Minneapolis, Toronto, Boston, Torino, Budapest, Tashkent, Beijing, or Hokkaido. These cities all have the density of urban fabric required. For issues related to cultural regionalism, readers are directed to Alberto Cabré's 1997 M. Arch. Thesis at M.I.T.

The site itself is diagrammed below, in an urban fabric not unlike Boston's South End. Major commercial streets run in the long direction, and smaller streets connect on offset regularity. The lots are divided perpendicularly to the street, with buildings on the street side and yards and alleys in the center of the street, in an H pattern. The site of the proposal occurs in the southern end of a block (*see figure 55.2*).

Program - the actual use of the building - would be determined by *how the people used it*. In other words, use = form. No particular program was chosen - just small scale domestic uses were implied in the form making decisions. In other words, housing, dormitories, small scale commercial (i.e. bookshop, laundromat), or perhaps a small school. Or any mixture of the above (that would be more positive). Following this, it is not a basketball arena, an airplane hangar, or a defensible fortress. It was imagined at one point that program could take a role in the decision making process, and this is discussed in Appendix 1 under the original proposal.



Figure 55.1.

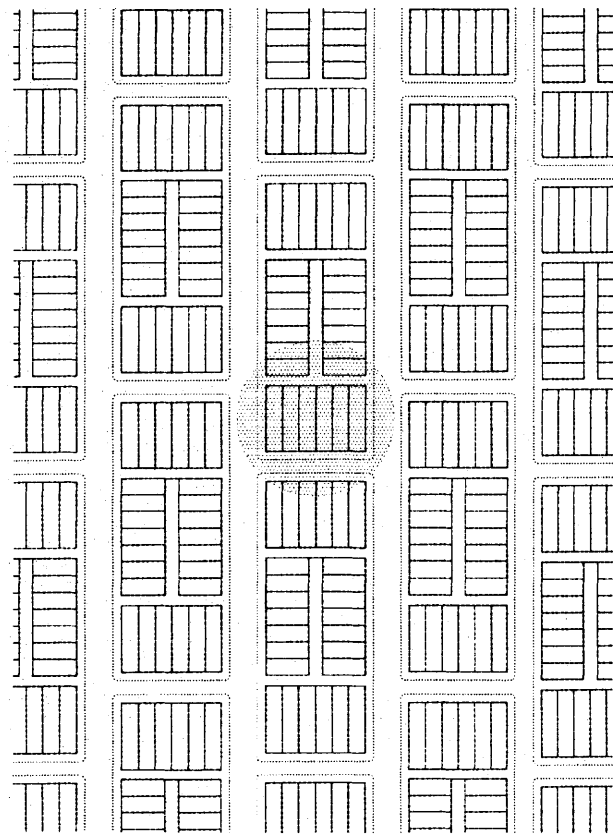

Figure 55.2 Parcel "X."

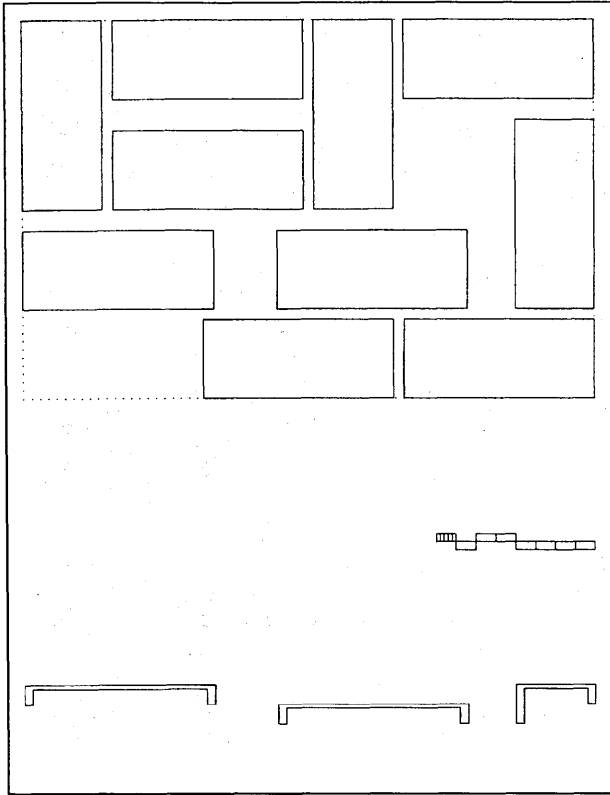

Figure 56.1 Floating slab deployment: plan +

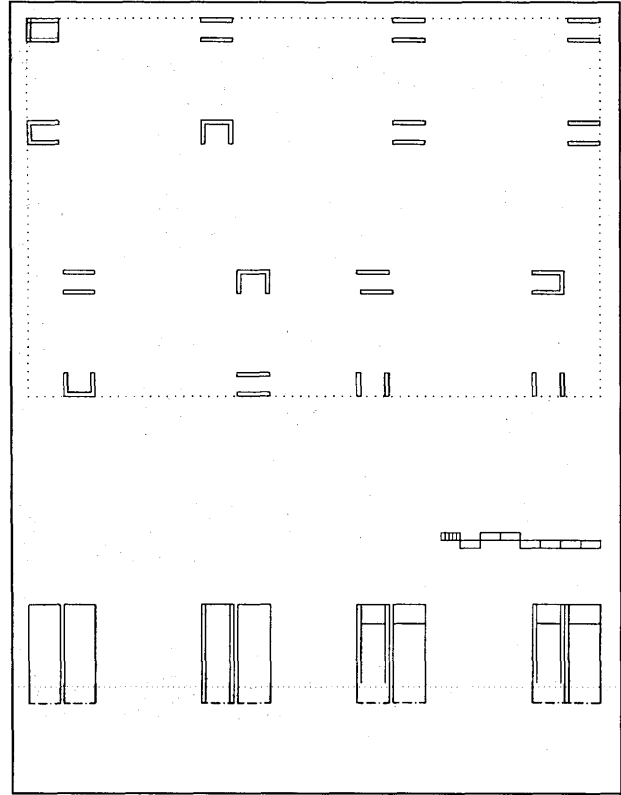

Figure 56.2. Vane deployment: plan + section.

The general attitude toward the site is to continue the direction established by the major public streets and to bring as much light into the site as possible while still achieving a reasonable density.

When looking at the diagram of the block behavior in this context, there appears to be a large amount of light along the center and parallel to the main street movement. This light mushrooms at the end (or dog bones) in concordance to the H shape of the alleys.

The second main feature (for this investigation's attitude toward the site) is that the shape of the corner becomes an offset cross. In order to make the most of this cruciform shape spatially, the corner of the site (in these deployments) has been largely unbuilt, and left at the level of the public access. Thus the form of the building will begin to take the shape of the form of the light.

These three figures (56.1, 56.2, 56.3) show various deployments of the first three system options at the foundation phase. It was decided to pursue the grade beam for this exercise, as shown next.

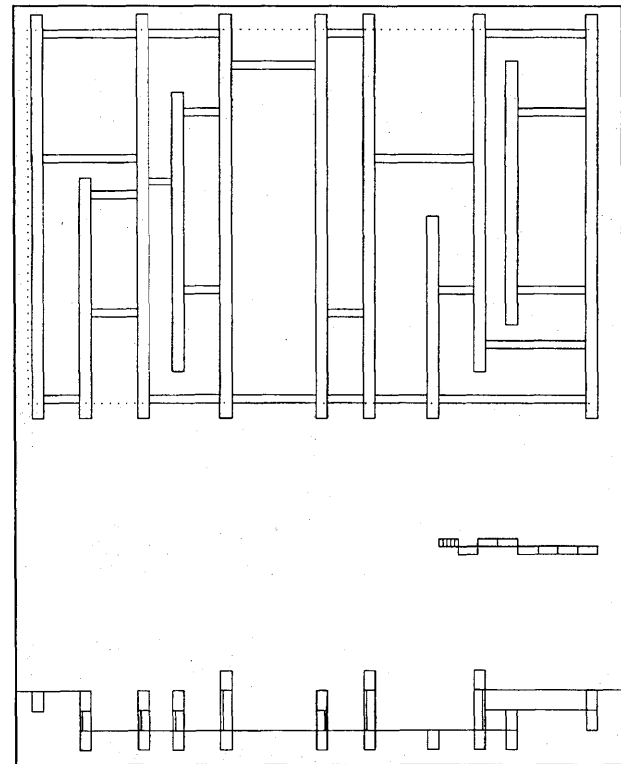

Figure 56.3. Beam deployment: plan + section.

In these two deployment schemes, a vertical support system has been added to the existing grade beam foundation. The frame deployment to the right shows a taller, less dense structure, with longer spans and more multi story definition. It will also yield more habitable floor levels at this early phase. The frames are deployed in bays which, when added up, grow in the direction counter to the public access, but parallel to the sites longitude. This defines the first level of privacy from the street level to the upper, residential (?) zones.

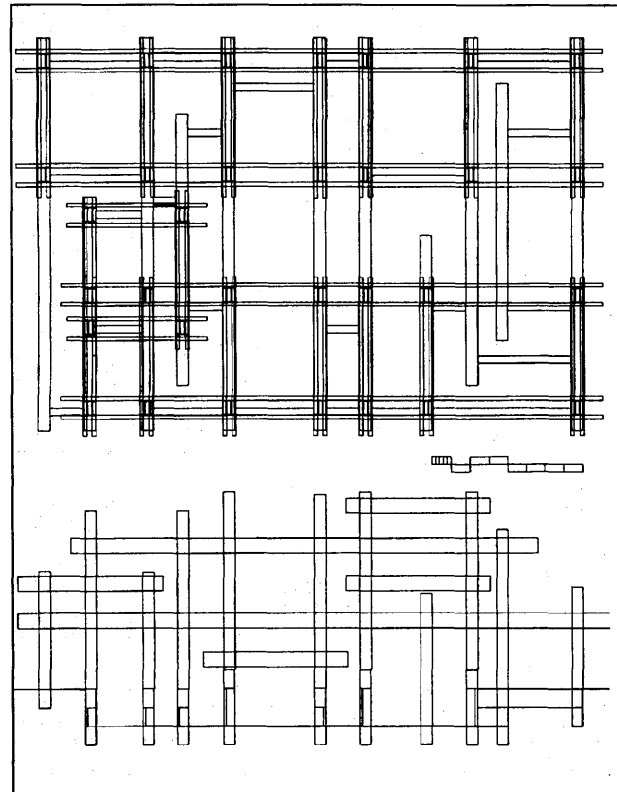

Figure 57.1. Frame deployment: plan + section.

This deployment of the folded wall begins to articulate the difference between the two systems approach and inhabitation of the site. Creating more vertical separation due to its construction behavior, the folded wall must fight to gain continuity in the normal direction. This continuity is key to a habitable access level in the direction of the private offices (?) in the upper levels. Also, due to its weight and stacked nature, it is not able to climb as high as the prestressed, precast concrete system illustrated above.

However, it does gain more definition of the smaller sized use forms due to the smaller size of its elements, and it was chosen to be pursued at the large scale model investigation for the remainder of this section. (circled in figure 57.2)

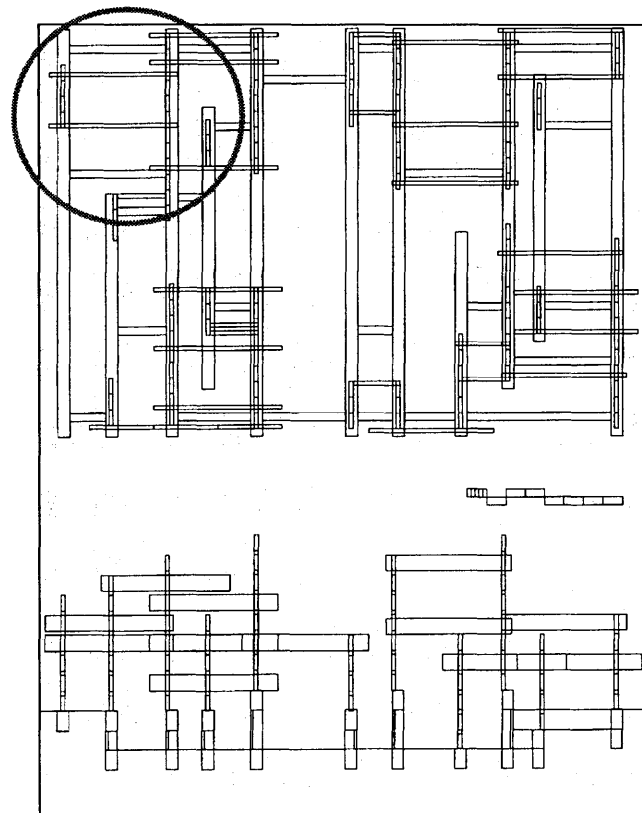

Figure 57.2. Wall deployment: plan + section.

PARALLEL SYSTEMS phase 1: foundation

The ground breaking phase would seem to be the most crucial decision, and have the most impact on the final project. That attitude is, however, exactly what the thesis is fighting. The whole point is to not have a committed and deterministic end result in mind. So the first moves on the site (as shown on the previous page) are to build the existing forces perceived. The grade beams move in the major direction and the foundation steps down in section to form a basement level toward the center of the site.

This deployment itself is a form of exchange between the public and private areas of the site. By allowing the one to move past the line of the next, an engagement is built and an entrance becomes evident..

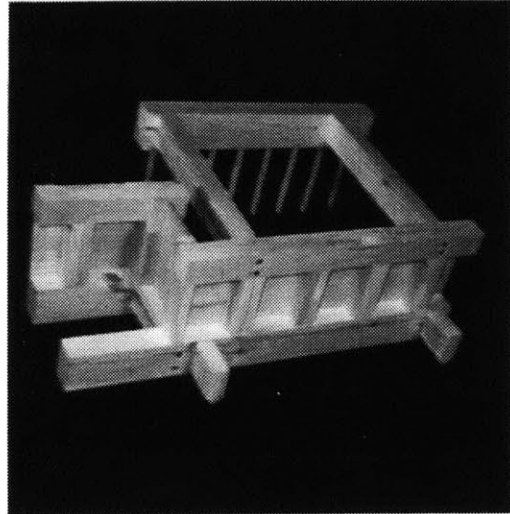

Figure 51.1 Grade beam foundation system

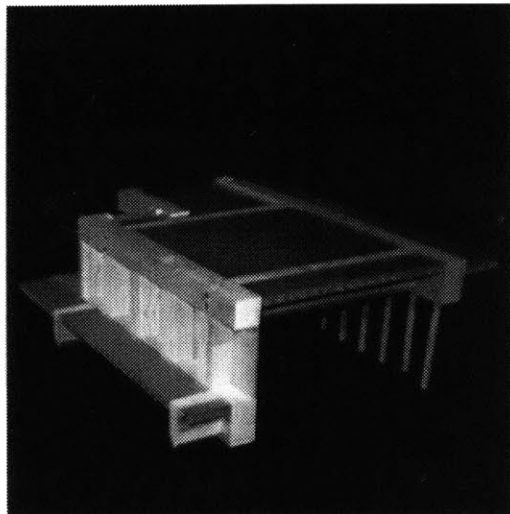

Figure 51.2 Grade beam foundation system

PARALLEL SYSTEMS phase 2: supports

This next system - the support wall - was imagined to be built in layers from the public edge toward the private center. They become more dense and taller toward what might become the separation between privacies in the back. Stabilizing beams are set into the staggered building elements to which they run normal. At some places the walls add up to just that: partitions capable of holding structure. At other times, the omission of a panel element, or the space between tow elements, can become fenestration or allow access. And still other times, the form of the wall begins to approach a vane or column behavior - when many small elements stack one atop the next.

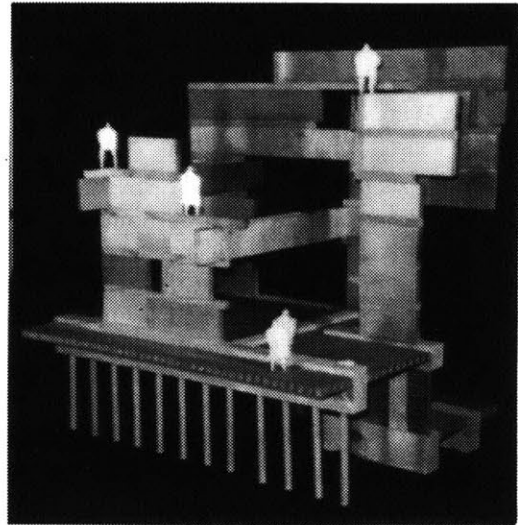

Figure 59.1 Wall plate support added

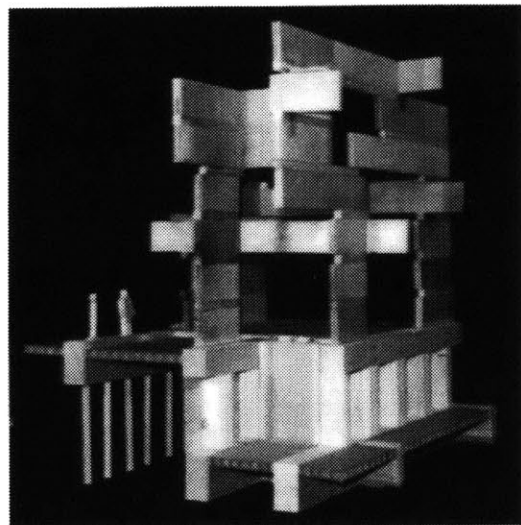

Figure 59.2 Wall plate support added

PARALLEL SYSTEMS phase 3: frame

Pieces of the vierendeel are sized at the same size of the first system. This one foot module of allows for the one system to easily fit in the space of the absence of the other. Phased in this way, however, it means that the truss can optionally occupy the staggered opportunity the folded wall system provides.

Able span upwards of 80' easily, the trusses are one floor deep, and it was envisioned that their deployment would begin to sketch in where floors might rest in the future. By deploying the trusses normal to each other in section (stacked like cordwood) an ongoing territorial reading is still present: these frames do not become virtual walls in either plan or section.

The prop used can be fit out on the site. It drops directly onto either the grade beam or the support, substituting for a wall or extruding from the grade beam. This flexibility is necessary to allow the systems to survive independently of the others.

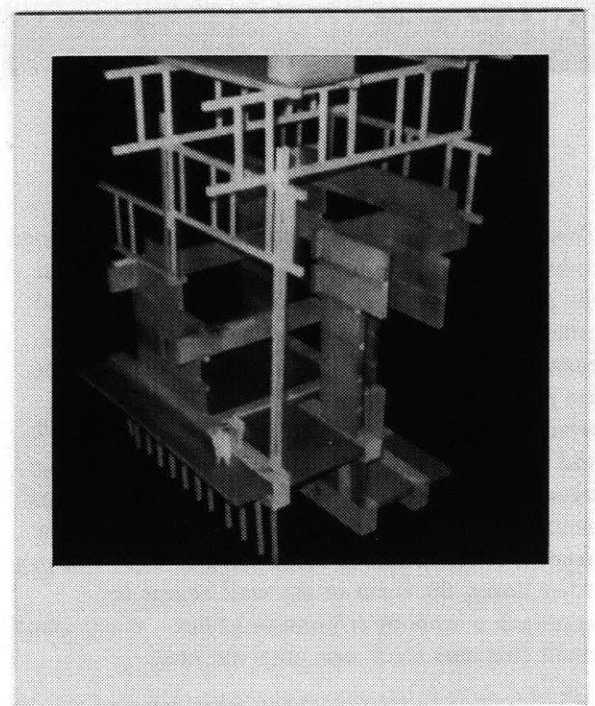

Figure 60.1 Vierendeel frame and prop system added.

PARALLEL SYSTEMS phase 4: floor

Floors are added in this phase, and the beginning of a habitable, three dimensional territory appears. This building component - for it is not truly a building system - fights as best it can to not act as a membrane stretched across existing definition. Rather than wholly seal up the preceding actions, they sit atop, or aloof to those actions. Suspended or resting on spacers (built light connections), the floors are slim enough to fit into the systems wither great tolerance.

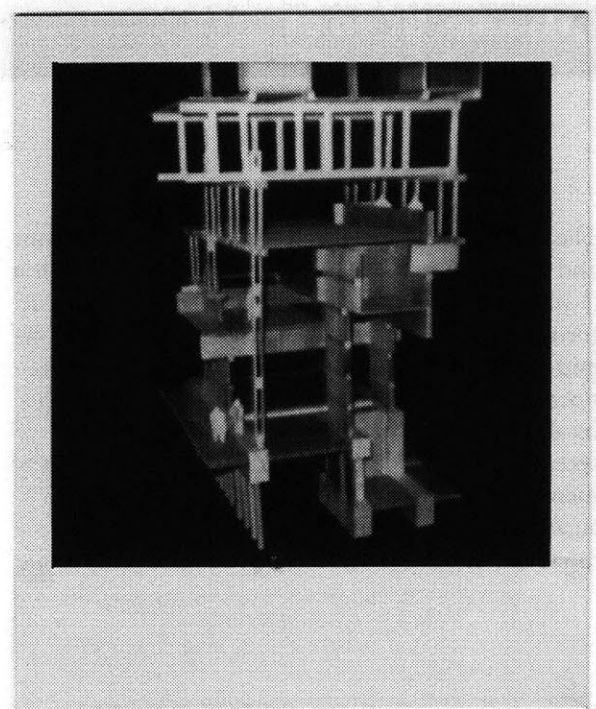

Figure 61.1 Hollow core slabs added

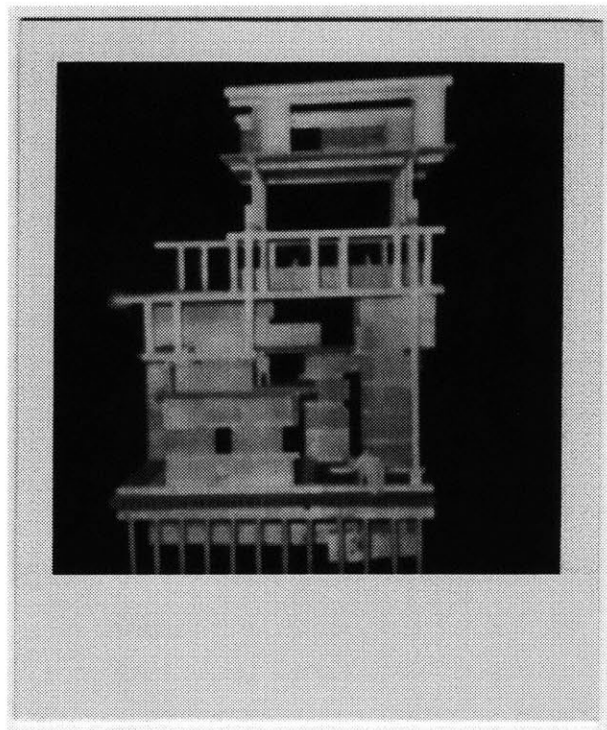

Figure 61.2 Hollow core slabs added.

PARALLEL SYSTEMS **phase 5: roof**

The truss roof spans at the top of the highest floor, and ends this sequence of investigation. Though it is still a long way from being a building, the basic form has taken shape, and further intensifications and built projections are greatly facilitated. This operation will be made more complex - and rich - by the addition of enclosure systems, stairs, screens, doors, balconies, bridges, etcetera. Not to mention mechanical and plumbing systems. Or surfacing actions and other evidence of inhabitation.

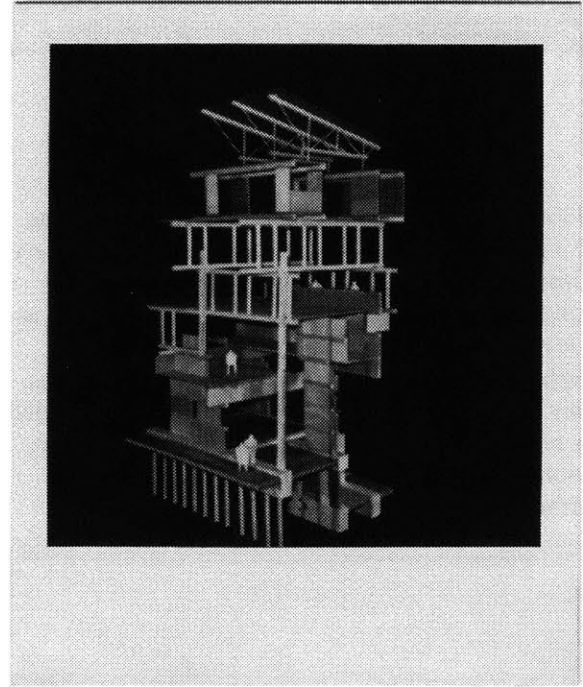
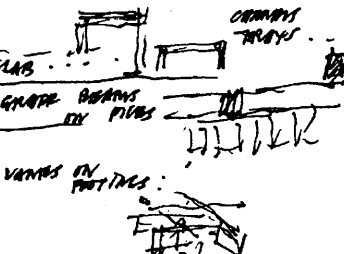
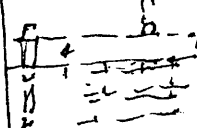
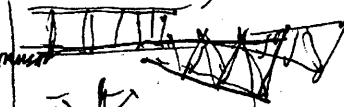
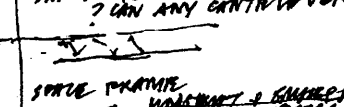
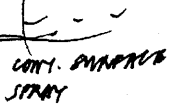

Figure 62 Roof truss added.

CONCLUSIONS

DRAWING SEQUENTIAL SYSTEM ASSIGNMENT	DRAWING SEQUENTIAL / NAME BY DESIGN	DESIGN FUNDAMENTALS # 4
<p>NEXT & REAL SITE (UNION) :</p> <p>NEED CRITERIA :</p> <p>FORMA : ? WHY SERIOUS WHAT YOU DID ?</p> <p>CF. AREA :</p>	<p>TECHNIQUE :</p> <p>① : GROUND SYSTEMS :</p>	 <p>SLAB</p> <p>GRATE BEAMS ON PIERS</p> <p>VIEWS ON FOOTINGS</p>
<p>NEED CRITERIA :</p> <p>FORMA : ? WHY SERIOUS WHAT YOU DID ?</p> <p>CF. AREA :</p>	<p>② : FRAMES :</p> <p>③ : ROOF :</p>	<p>PIERS FINISHED BUT DOUBLE CUT IN WALL + CONTINUM</p>  <p>PRESENT DOUBLE CUT (PI) V. IN PLACE...</p>
<p>NEED CRITERIA :</p> <p>FORMA : ? WHY SERIOUS WHAT YOU DID ?</p> <p>CF. AREA :</p>	<p>④ : FRAMES :</p> <p>⑤ : ROOF :</p>	<p>VIBRATIONS THROUGH STEEL</p>  <p>TRUSS</p> <p>PROB. STIFFENING</p> <p>PROB. STIFFENING</p>
<p>NEED CRITERIA :</p> <p>FORMA : ? WHY SERIOUS WHAT YOU DID ?</p> <p>CF. AREA :</p>	<p>⑥ : FRAMES :</p> <p>⑦ : ROOF :</p>	<p>PROB. STIFFENING</p> <p>PROB. STIFFENING</p> <p>BAR OFFER ? CAN ANY CONTRAIVER</p>  <p>SOME FRAME HOLDING + SUSPECT EXTEND BOARD</p>
<p>NEED CRITERIA :</p> <p>FORMA : ? WHY SERIOUS WHAT YOU DID ?</p> <p>CF. AREA :</p>	<p>⑧ : FRAMES :</p> <p>⑨ : ROOF :</p>	<p>SMITH PLANE CORNER TESS</p>  <p>SMITH PLANE CORNER TESS</p>
<p>NEED CRITERIA :</p> <p>FORMA : ? WHY SERIOUS WHAT YOU DID ?</p> <p>CF. AREA :</p>	<p>⑩ : FRAMES :</p> <p>⑪ : ROOF :</p>	<p>CONT. SHAPES KOLD STRAY</p>

DIRECT SEQUENTIAL SYSTEM ASSEMBLAGE

Daniel M. Sandomire
Bachelor of Arts in Architectural Studies
University of Washington
Seattle, Washington
June 1994

SUBMITTED TO THE DEPARTMENT OF ARCHITECTURE
IN PARTIAL FULFILLMENT OF THE REQUIREMENTS FOR
THE DEGREE OF
MONSTER OF ARCHITECTURE
AT THE
MASSACHUSETTS INSTITUTE OF TECHNOLOGY
FEBRUARY, 1997

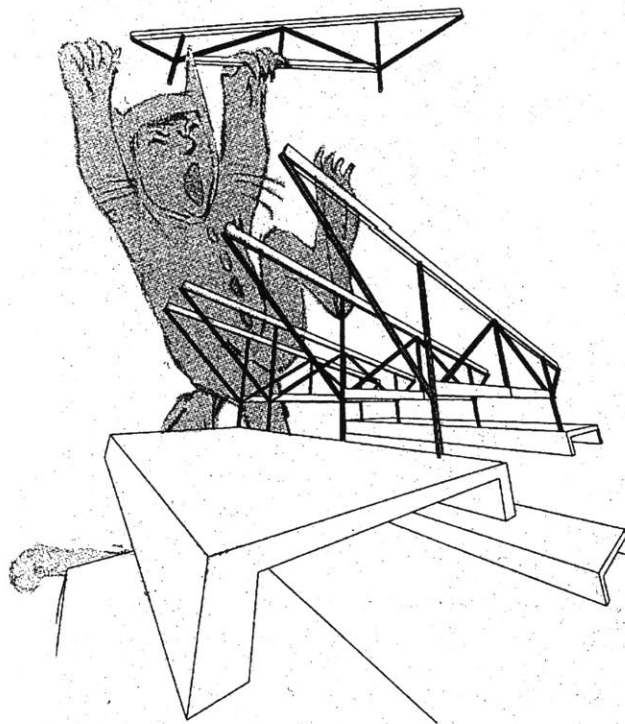

THESIS SUPERVISOR:

Maurice Sendak
Professor, with Merit.

APPENDIX 1: alternative exercises

One of the greatest tasks the thesis undertakes is the development of the thesis itself. The directions and paths the thesis investigation took are themselves clues as to the nature of the problem, and are recorded here with some discussion as to the directions perceived at the time and critical reflection after the fact.

Which brings us back to the quote that began this thesis by Francis Ponge, in which he discusses how to write:

“You have first of all to side with your own spirit, and your own taste. Then you take the time, and have the courage, to express all your thoughts on the subject at hand (not just keeping the expressions that seem brilliant or distinctive). Finally you have to say everything simply, not striving for charm, but conviction.”

What is recorded here is the process and attitude that generated and criticized the work of the semester. The exercises are left here as partially explored potentials, with notes as to possible directions they might take, and what benefits those directions might yield. They are as follows:

1. Concentration Proposal + Intent of Study
2. Thesis Proposal (partial)
3. Built Attitude Statement
4. Reference Transformation
5. Reference Collage
6. Rural Site Assemblage
7. Parcel “X”
8. Support Frame Infill.
9. Whole Site Assemblage

Daniel Sandomir
September 1995

Concentration Proposal

The designer's place in the production of architecture is a rapidly changing one. It is evolving from the role of the gentleman architect to that of a bystander. The architect (as we are studying in school) is nearly obsolete.

I recognize there is a huge gap between what is taught in school and what is actually practiced, but I have always held faith that I would not fall victim to the plundering developer, the mediocre contractor and the almighty buck. And in my concentration proposal I hope to gain some tools for that endeavor.

The earlier one enters the building process, the more influence one has. Often the architect is the last to hear about the building, and handed a tight budget and schedule. In today's construction field, fast track buildings are becoming the norm- buildings built without complete plans, not completely financed, and dozens of other factors up in the air. With all this confusion, developers and contractors stick with tried and true methods of construction, resulting in a box which they hope to sell as soon as possible.

An architect knowledgeable with the building process can step in and introduce money saving proposals and good design solutions to a building as it develops in this milieu. At least, that is my hypothesis...

My thesis proposal would be a simulation of a fast track building process, making it a game of budget, scheduling and design. I have compiled the following list of classes which would help me set up the rules of the game, and suggest solutions and directions to take.

Class List

1.413	Construction Technology and the Building Development Process
1.46	Strategic Management in the Design and Construction Value Chain
4.276J	Design Research Seminar: Architectural Programming
11.303I	Design for Urban Development
11.304J	Site and Urban Systems Planning
GSD1212	Planning and Design of Landscapes

Daniel Sandomir

THINK QUICK!

WORKING
TITLE

Direct Sequential System Assemblage

Daniel H. Sandomir

Merica K. Smith, Advisor

Andrew M. Scott, Thesis Prep. Coordinator

ABSTRACT :

Decisions made during the construction process have the opportunity to both inform the next set of decisions and provide unexpected and possibly positive features in the final project. Each decision responds to, but is not controlled by its specific environment, as well as contributes to the environment for future decisions. Thus, working beyond the minimum definition at each size will provide a more rich environment for the next...

This thesis proposes to investigate those decisions both analytically and synthetically. The first task will experiment with ordering and making decisions hierarchically (ranked) and subdivisionally (in terms of building systems and organization systems). These parallel systems investigations will then provide the background for the second task of this thesis: a practical application of the methodology in an architectural project.

BACKGROUND :

This thesis is structured to be a bridge between my academic experience and my professional future. An investigation charting several possible paths a designer might make will inform the decisions I will make. Often, it is making decisions, not coming up with solutions, that is the designer's greatest challenge. My thesis is about making those decisions, quickly and severally.

DECISIONS

One way to make decisions, which has created the demand for the design profession, is to delegate them to another. For some decisions, I intend to do just that. I will set up the environment within which other designers will work. This will simulate both the multiplicity of decisions and the organization of them. It will also test the framework in which I make decisions.

DECISIONS

Another way to make decisions is by chance- the equivalent of throwing a dart. I will use this process in two different ways. The first will be to simulate those contingencies which are beyond the control of the designer, such as a construction catastrophe. The second way will be to make this random choice conjunctively with other decisions, keeping my own decision making in check by forcing me to work with ideas that I might otherwise not have made.

DECISIONS

The traditional model of design is a cyclic process: the designer makes a decision, reflects on that, and follows it with another. At some point of completion, the designer then uses that experience to inform the next iteration of the entire process- starting over again, having learned something. This is often described as intuitive, inspired, and internal. Every time I draw and redraw an idea, I will be using this process.

DECISIONS

Another method in making decisions is to find as many alternatives as possible, and then choose from among those which one will most probably yield the best future for the next set of decisions. The next set reacts against [not informs] the previous actions. The decision tree is explicitly hierarchical linear and external. When employing this method, I will be able to schedule, catalog, and compare decisions.

FRAME
WORK

The first course of the thesis will be to explore and compare alternatives as specific options. These experiments are structured to accomplish the following:

1) force the issue of using a single system at any one time rather than hybrids. The 'pure' system, once deployed, could then be evaluated and compared to other systems. This happens at each tier, and allows for the tracing back of what first lead to those decisions. The criteria for judgement is finding which systems work well with which others, and how specific deployments can be made to offer more hospitality to future intensifications.

2) explicitly avoid singular (goal-oriented) design. This plural, parallel approach forces discoveries, and having to deal with a series of choices I might not otherwise have made. I might find that among five alternatives for a primary system, there would be three chosen and deployed. The next round would have another five alternatives for a secondary system, and three of these would be chosen and deployed in the existing context of each of the three previously established contexts. This results in a set of nine different designs, or landscapes, in which to continue with the three in five process- resulting in a total of twenty seven. I expect that in keeping these decisions truly independent, some branches would necessarily die: a bearing wall above a pier foundation would be one potential impossibility.

length of the semester]. Such scheduled factors would be: services, sewers, roads, foundations, and the various built systems employed.

Contingencies will take place (drawn from a hat) such as: the discovery of ancient artifacts which halt construction in one area of the site; a major building system will suddenly become very inexpensive (thus encouraging the use of it); the actual program will be determined specifically after the building has started; and custom fitouts of shops and units in the form of a school-wide weekend charrette- barring that, incorporation of precedent studies.

PROJECTIONS

The following chart traces this basic behavior:

alternatives	A	B	C	D	E
decisions	*		*	*	
designs [3]	A		C	D	
alternatives	1	2	3	4	5
decisions		*		*	*
designs [9]		A2;C2 D2		A4;C4 D4	A5;C5 D5
alternatives	a	b	c	d	e
decisions	*	*	*		
designs [27]	A2a;A4a A5a;C2a C4a;C5a D2a;D4a D5a	A2b;A4b A5b;C2b C4b;C5b D2b;D4b D5b	A3c;A6c A5c;C3c C4c;C5c D2c;D4c D5c		

PROJECT

The second course of the thesis will be an application of this methodology to an architectural project. The design process will be both artificially accelerated and hampered by strict scheduling and unexpected contingencies. Here, the various alternatives will be selected and played against the forces of the site and program (contingencies) and at later times in the development of the building pursued parallel to each other.

The site is located on the edge of Honolulu's downtown, where the city begins to transform into an industrial area (surprisingly close to a residential neighborhood).

The program will be for a mixed use of retail, office, and residential. The exact amount of each will be variably assigned during the course of the project, but I anticipate the total of approximately 75,000 square feet.

Scheduling will be phased to simulate the actual construction of the project (accelerated to meet the pace and

SCHEDULE

April - May: Thesis preparation; developing the building vocabulary in the Form Language Workshop.

June - July: Site Research; continue developing the building vocabulary; begin parallel systems investigations.

August: Parallel systems investigations continue; meet with advisor to discuss the results.

September: Fall Semester begins.

Weeks 1-3: Parallel systems investigations continue.

Week 4: Conclude parallel systems investigations. Documentation and Analysis.

Week 5: Architectural Project begins. Site plan, services and parking. Contingency No. 1 determined.

Week 6: Structural foundations deployed. Contingency No. 2 determined.

Week 7: Primary/ Large structure deployed.

Week 8: Secondary systems deployed. Program determined.

Week 9: Enclosure Systems deployed. School wide charrette held for custom fit-out simulation.

Week 10: Thesis content review.

Weeks 11-14: Documentation & Final Presentation.

EXERCISE 68: built attitude statement

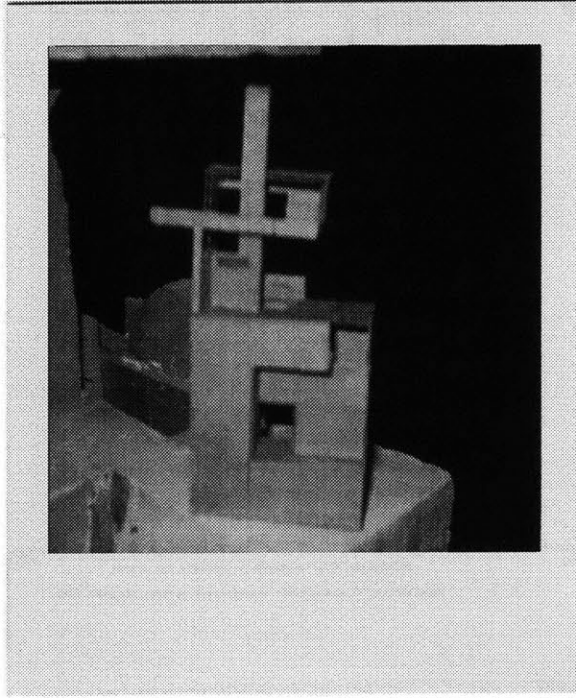

Figure 68.1.

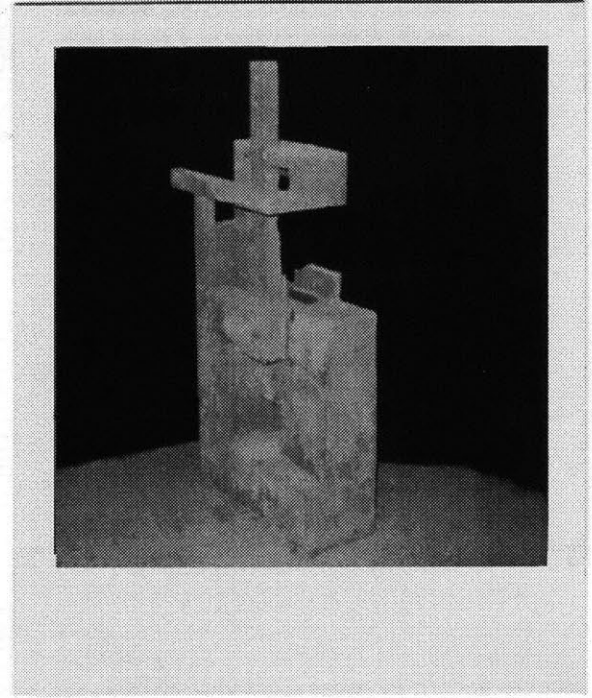

Figure 68.2.

This exercise began with three intentions.

The first was as an exercise in which each decision made was recorded, independent of perceived importance. In this way, the decisions could be ranked and it could then be determined which decisions had the most impact on the final outcome.

The second intention was to explore formal transformation within a single material system. As evidenced in the above photographs, the concrete starts on the ground as a solid with removals. These removals gain in size until the object is mostly a folded plate system, always returning on itself. Each of these key shaped plates rotating adds up to a volume definition until they exhibit frame behavior in the end.

The final intention was to evoke some of the material qualities and spatial variation I felt was important to my attitude. By having a direct association with a physical system, I believe that

the decisions made down the road would be richly informed and better for it. This sculpture/building simulation could become both an abstraction and formalization of a built event.

This investigation intended to continue with a secondary system of precast concrete beams and columns, and then on to different material systems such as steel, wood, and so on. Each system would move more and more toward screen behavior, until the smallest system added up to a virtual continuous surface, such as the ground form which started it all.

EXERCISE 69: referenced collage

This series of exercises began with my investigations of case studies. It became apparent to me that if the first system was not supposed to control the final product, there should be no reason to be overly concerned about it. As long as there was a physical associative presence and a generic order in operation, reasonable decisions could be based on nearly any landscape situation.

The decision to take references of reasonable building systems deployments was made as an effort to jumpstart the process. The first reference-Charles Correa's Loom Pavilion was chosen for its clearly articulated continuous surface ground form. All subsequent systems were removed from the project, along with any notion of program. The next system placed was Otto Steidle's half story haunched frame. This, once deployed at a larger definition than the original ground form, was then inhabited with a third system of wood beams and canvas roofs.

If one were to continue this exercise, it would be necessary to first choose the range of references, and having this in mind, deploy them in successive passes.

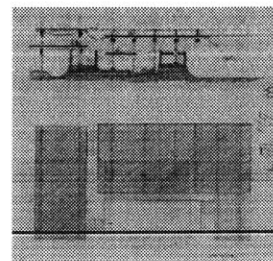
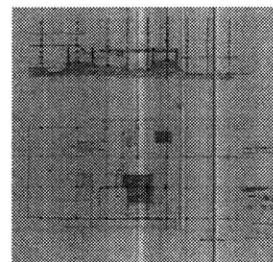
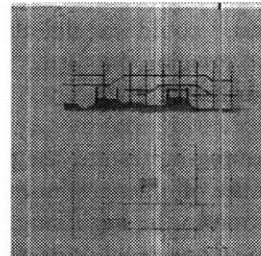
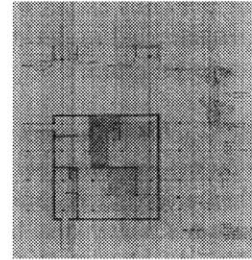
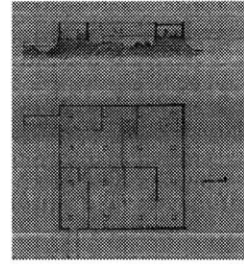

EXERCISE 70: referenced transformed

Based on a struggle in making decisions experienced in the previous exercise (reference collage), this approach tried to develop a response mechanism based on program.

Schindler's Lovell Beach House was stripped to its concrete pierced planes (an unstable cantilever condition) and then a second system was chosen: a suspended floor from a heavy steel beam which in turn would stabilize the planes. Prior to their deployment, a program was assigned to me by Bill Scholtens: small school.

With this in mind, I could imagine the use of the building - and so imagine the form. The building developed in four hours.

Despite the encouraging results, the path was abandoned because of a general uneasiness with its unearned definition in the beginning. The next attempts show a strong reaction to this feeling.

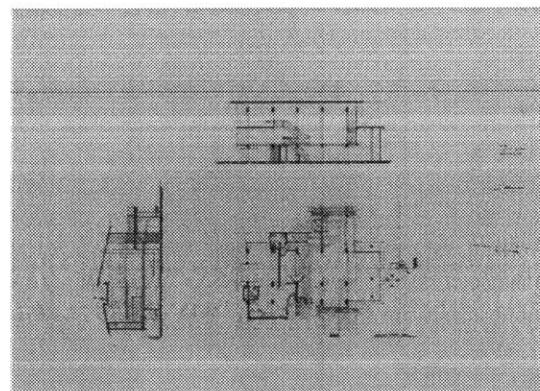
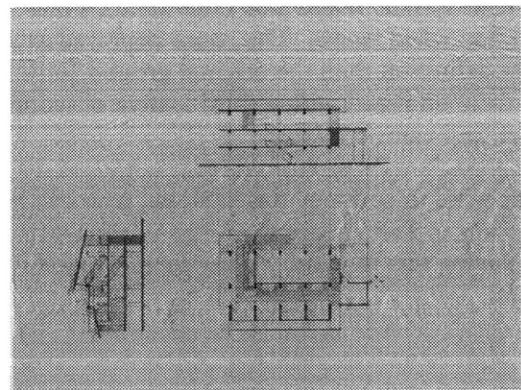
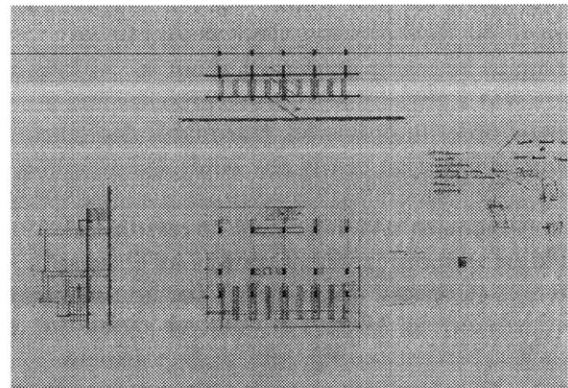
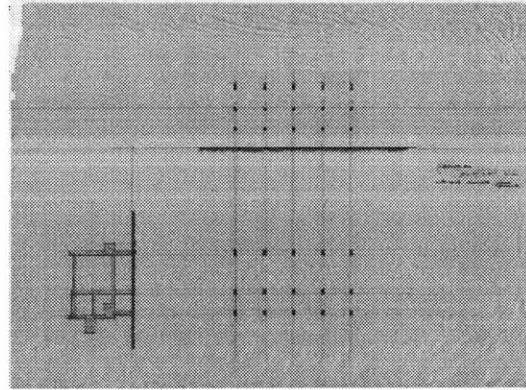

EXERCISE 71: parcel "x"

Parcel "X" began with a generic site - the end of a block in Boston's South End neighborhood. Similar to the built attitude statement, decisions were made in an intuitive, sculptural manner. And this was exactly the problem.

Having no real system for decisions from the beginning, the project developed slowly as it tried to figure itself out. Each decision growing only out of the decision just prior to it. In the end, what developed was interesting spatially as a partial building, but devoid of any convincing and understandable generic behavior. As a result of this approach, each decision is entirely idiosyncratic and ad-hoc.

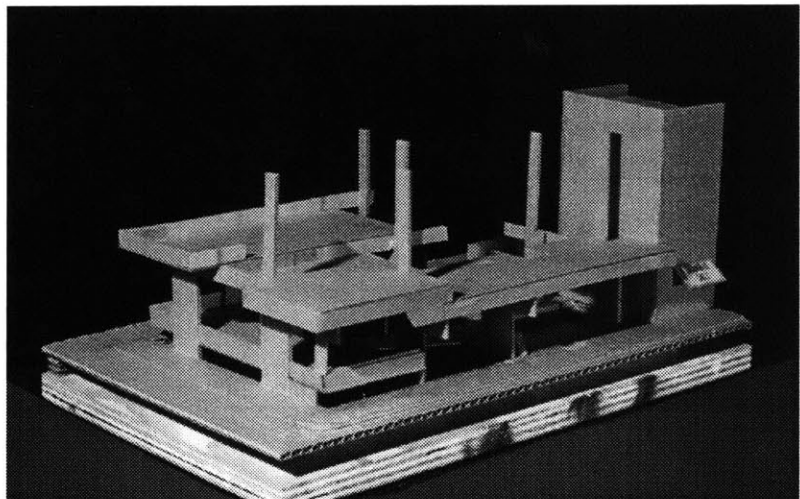
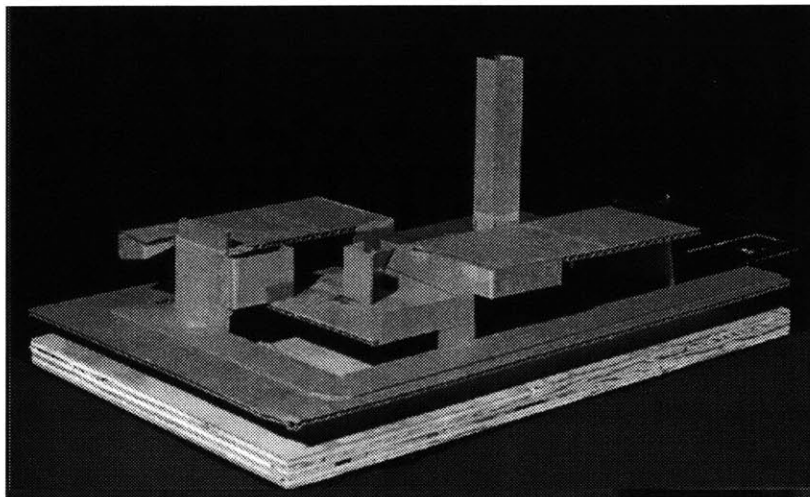
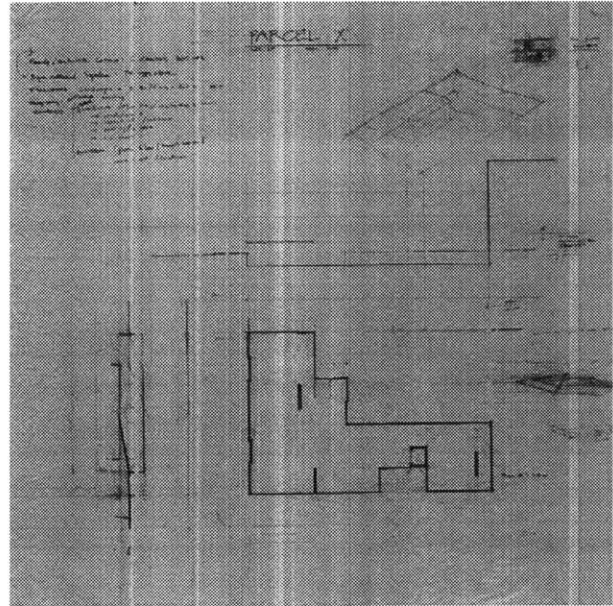

EXERCISE 72: rural site

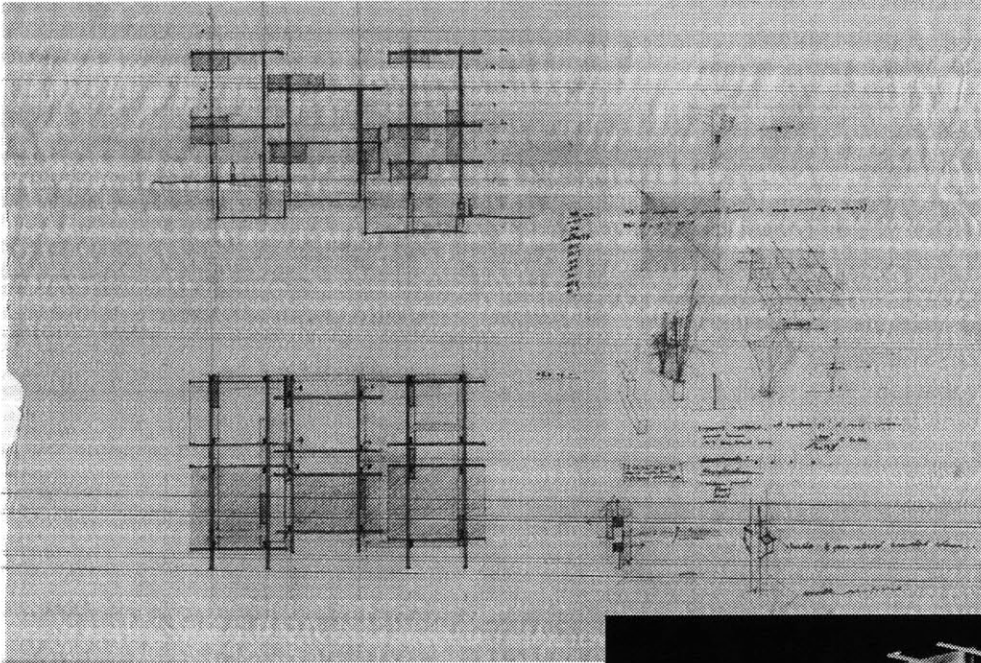

Discussions within Imre Halasz's thesis group (consisting of Steve Bull, Miguel Del Rio, Bill Scholtens, Dierdre Terzian, and myself) prompted this exploration into a site without violent urban constraints. The site became, in a way, the first design element: a gently sloping ground plane with southern exposure and as much land as was wanted...

The first impulse was the wrong one (if I may be so bold). Basically, the cut was made into the site as though it were an urban project. A hole into which a building might "fit." Then, using a dimensional system of rooms, and building sizes, foundation walls were brought up into space.

Upon this system a frame was set-bridging over walls and bearing on them. And as the walls passed the footing columns, exchange between the systems could be observed.

This exchange was minimal, but encouraging. In general, the two building languages were surviving on their own and in dialogue with the other. As the walls had preceded the frame, it was certainly

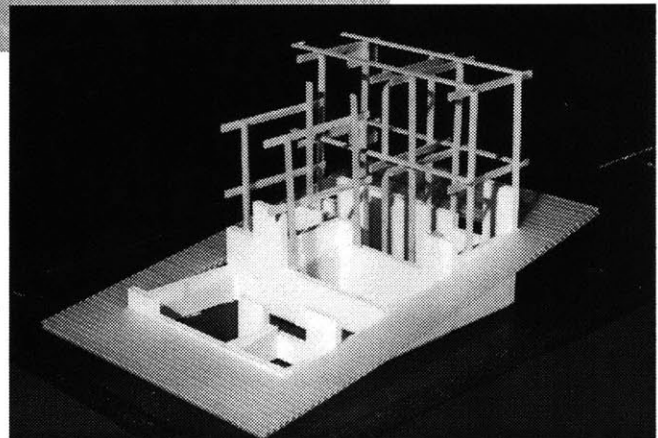

independent, but is just a certainly anticipated the next system. When the frame came along, it was restricted by the decisions made in the first deployment, but it could act at multiples of the original size, and at a different rhythm, allowing it to act independently as well.

The attribute most lacking was a full range of exchange possibilities. These two building systems were nearly interchangeable at times. This substitution attitude in the system deployment was one of the largest stumbling blocks this semester.

EXERCISE 73: support frame

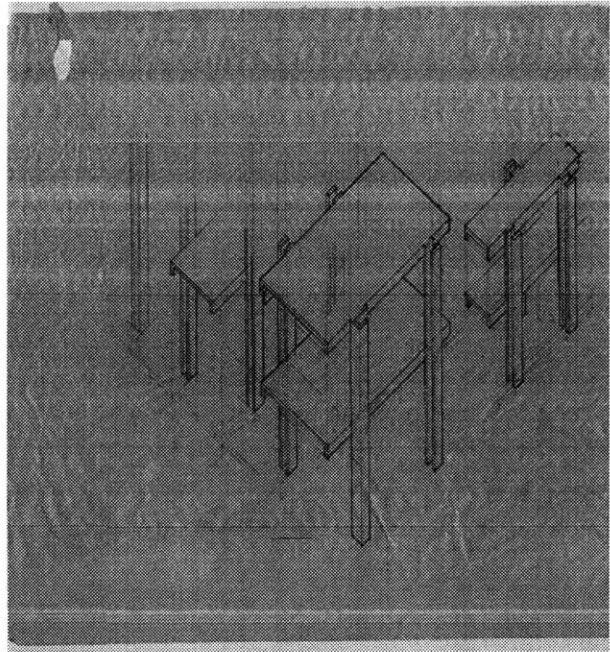
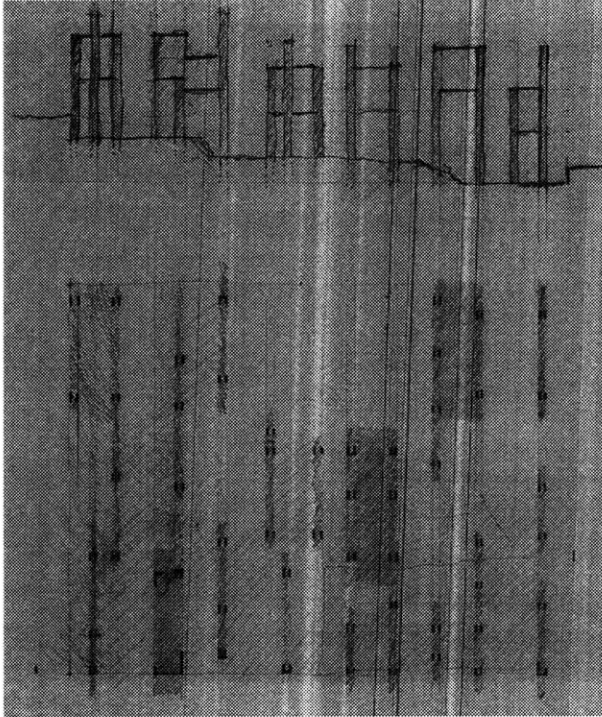

This approach developed after a discussion with Bill Hubbard. It was felt at the time that rather than move in a direction of advocating systems and physical, territorial definition, I should actually begin to pursue in specific a program, or developed program element. By using a support-type structure, any program could be accommodated and the structure would have the option of either being present or not.

Selling off the physical systems gave a lot of room to breathe, but almost too much. Rather than being trapped in the manner of the parcel "x," there was almost too much pressure here to be graphic in the application of the design. It quickly moved to a point where I actually sketched out the facade of the building. Absolutely selling any process or development along the way. An end result building was being drawn on my very board.

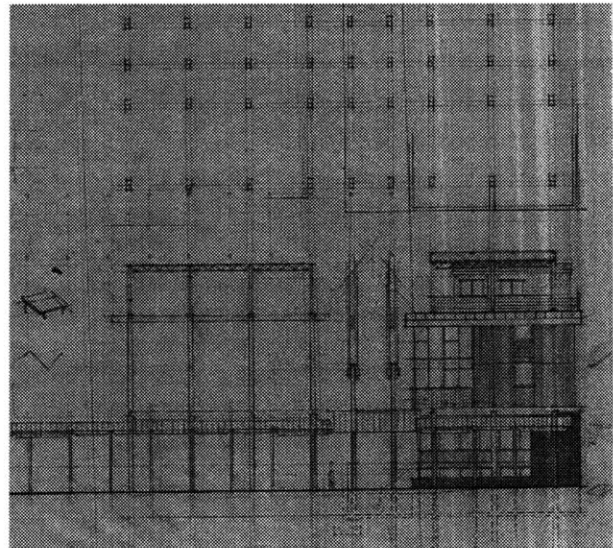

**EXERCISE 74:
whole - site assemblage**

This next series of exercises attempted to deploy the systems at the entire site size. Using modeling methods that closely followed the system behavior, the trials shown over the next three pages illustrate the collage of two to three systems in the process.

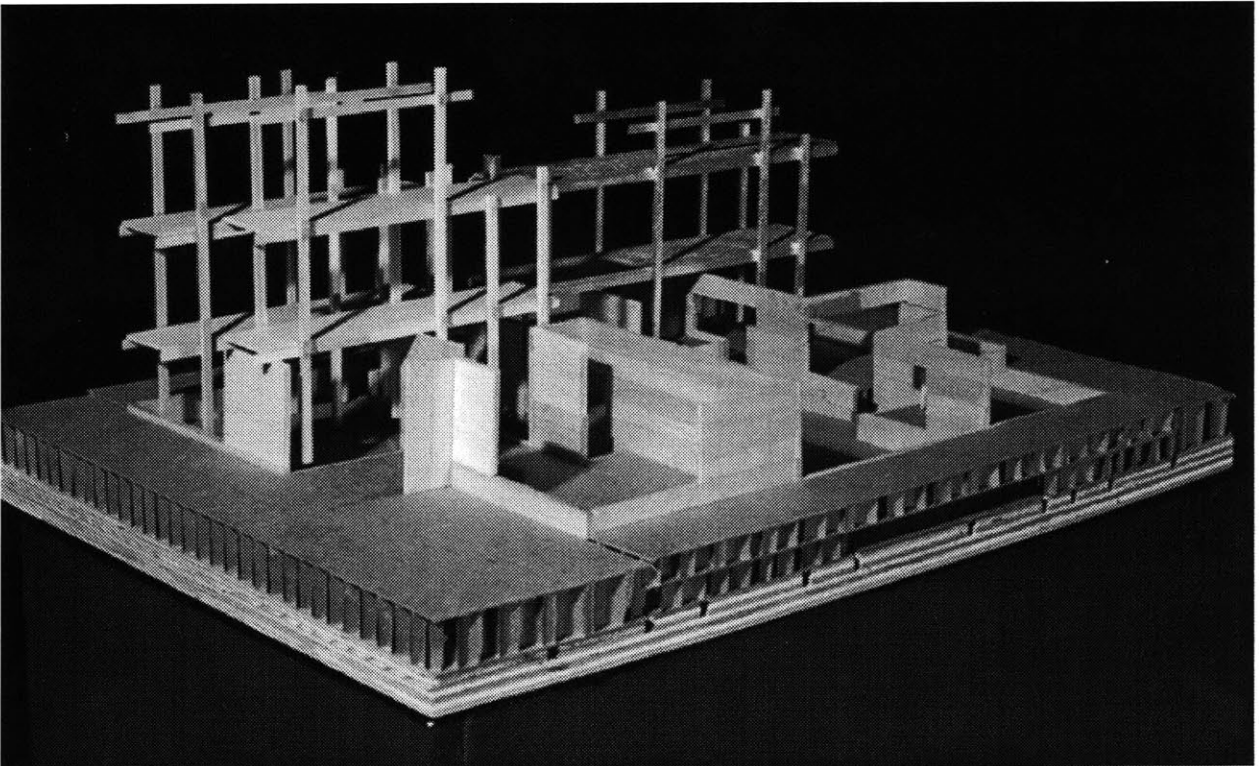
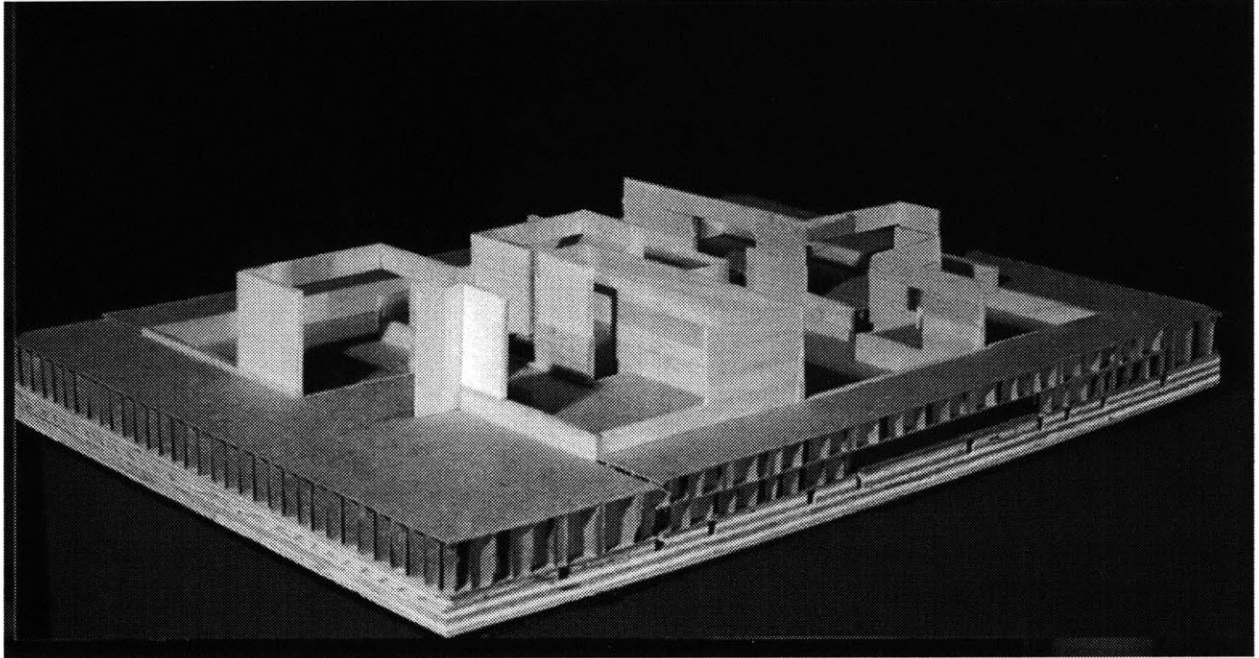

Once the base for the model was determined (still using the generic site description), the preliminary ground forms were deployed at the building size. In doing this, the larger continuities of the landscape and public direction were reinforced and still options at the next set of decisions.

Following this, a system of support - a vertical system was deployed. This system gave optional privacy and three dimensional territory. This set of sequenced developments yielded strong variety throughout the building field.

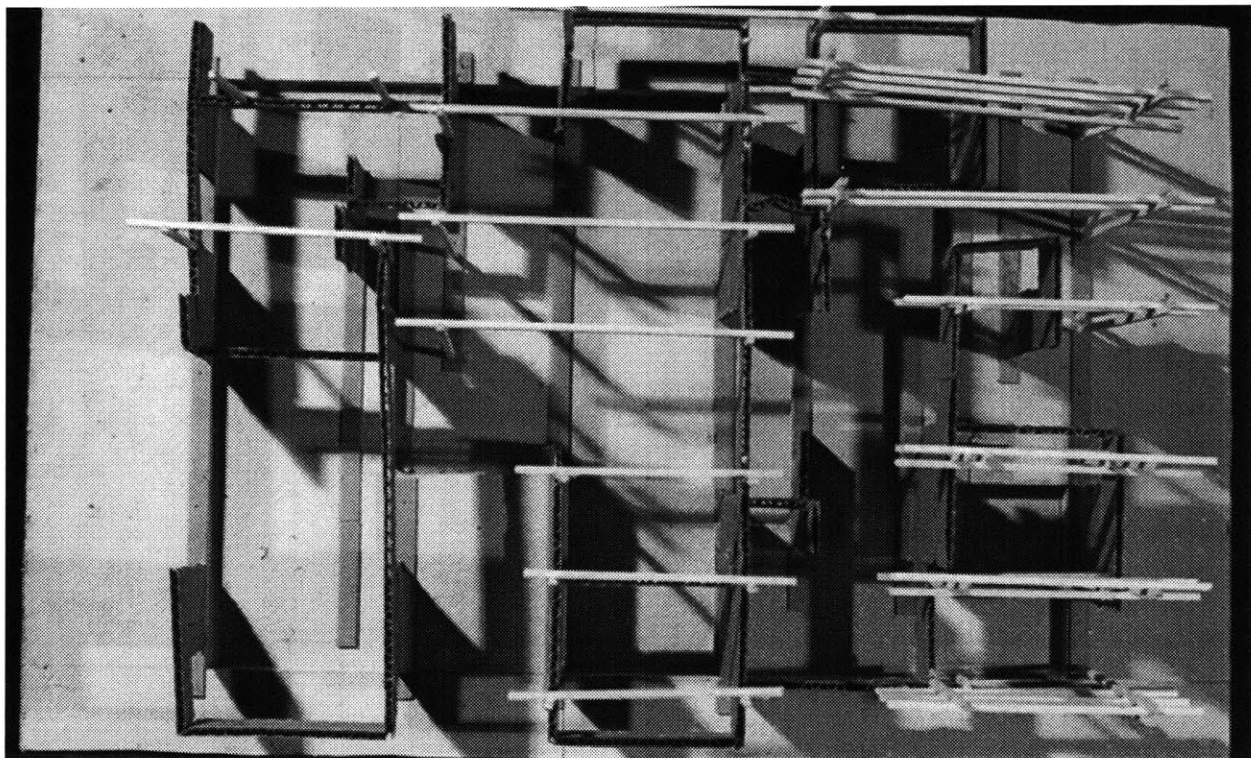
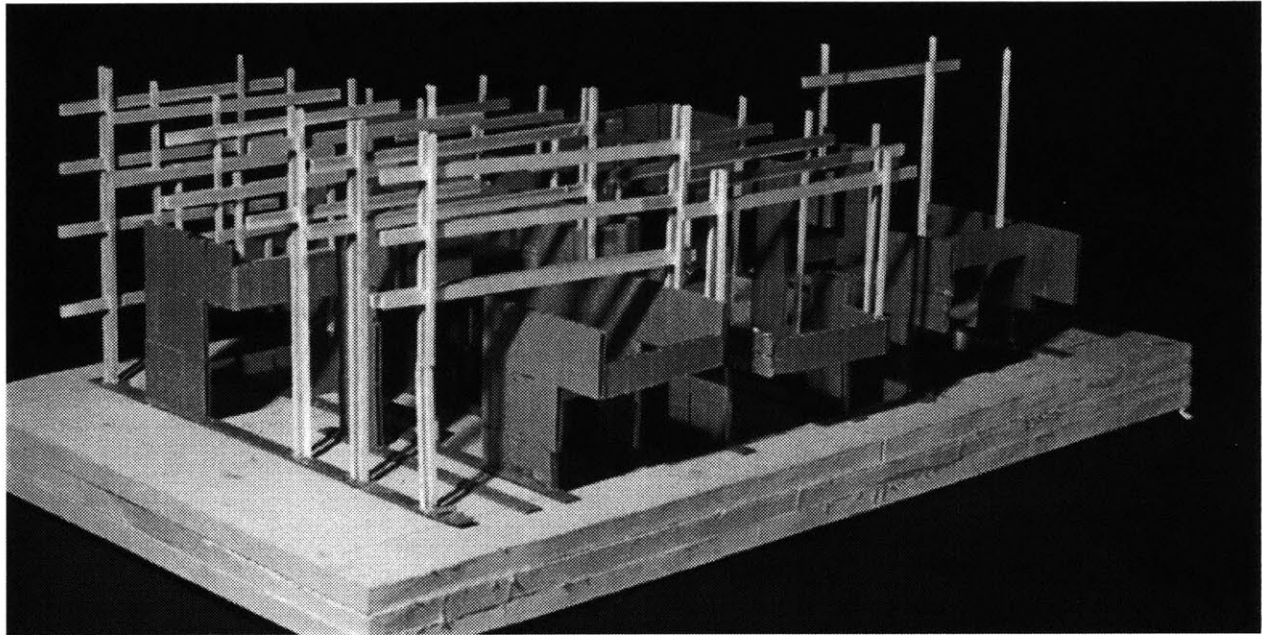

When the third system - either a frame or a screen- was introduced, problems with the scale became an issue. The behavior of the system simply required more attention than it was getting. Deployments became diagrams of decisions, and could not be referred to in specific for the next set of decisions. Floors became impossible. The addition of them became merely a membrane

covering the balloons of framed territory defined. Walls were much the same, and roofs had to be deployed so independently (in this diagrammatic manner) that they became hats, practically. Exchange - habitable (light, level, space) was impossible.

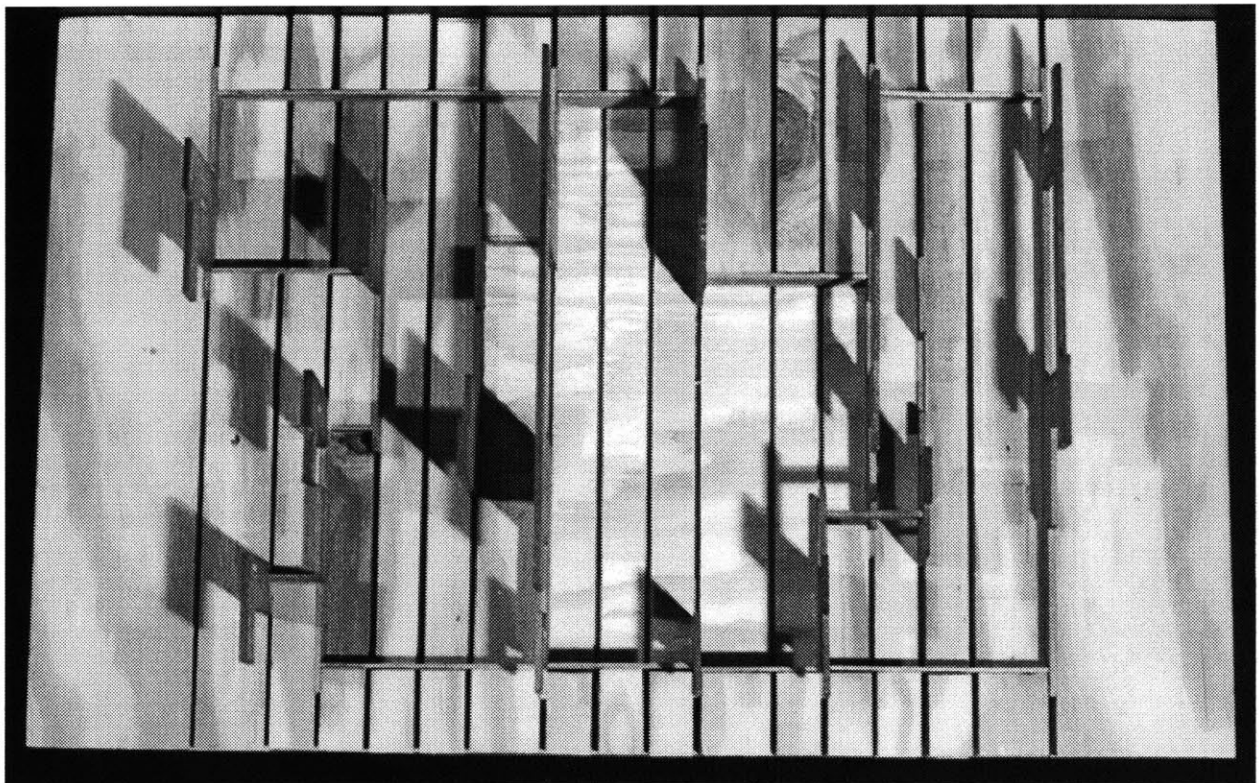
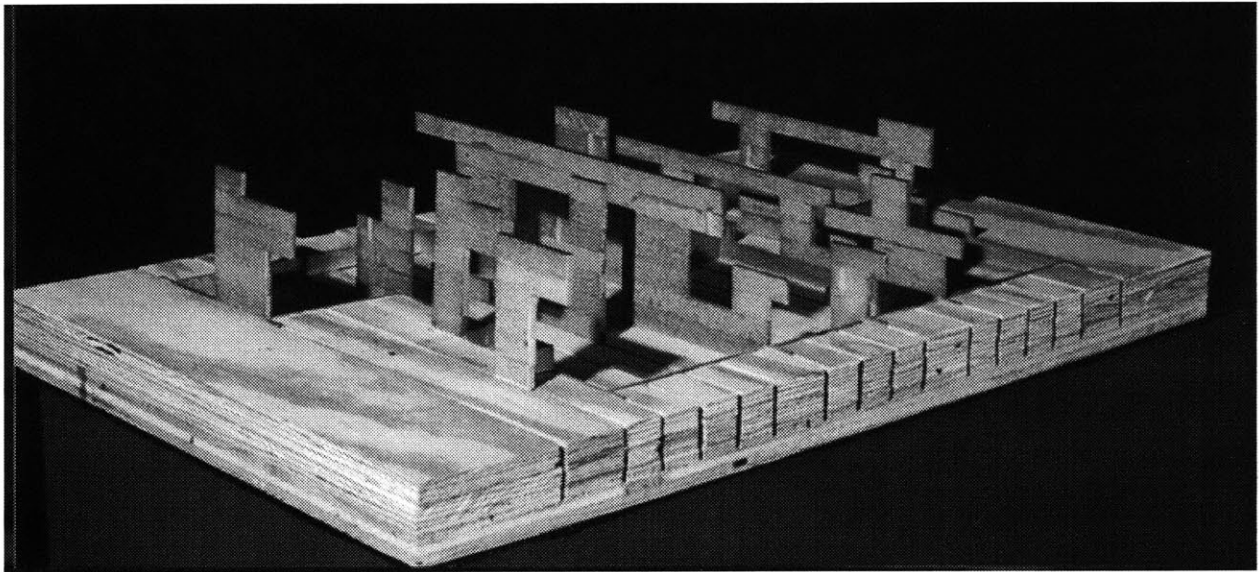

The decision to move to a larger scale and work on only a portion of the site followed this series. Systems had been cataloged. Decisions about site established, and a manner in which to work were all present. The partial large scale parallel system investigation followed this.

So I reach the same conclusion many of my colleagues have. More time is necessary to explore this avenue, but I feel confident that my preliminary investigations here under M.I.T.'s guidance will well equip me for that continuity.

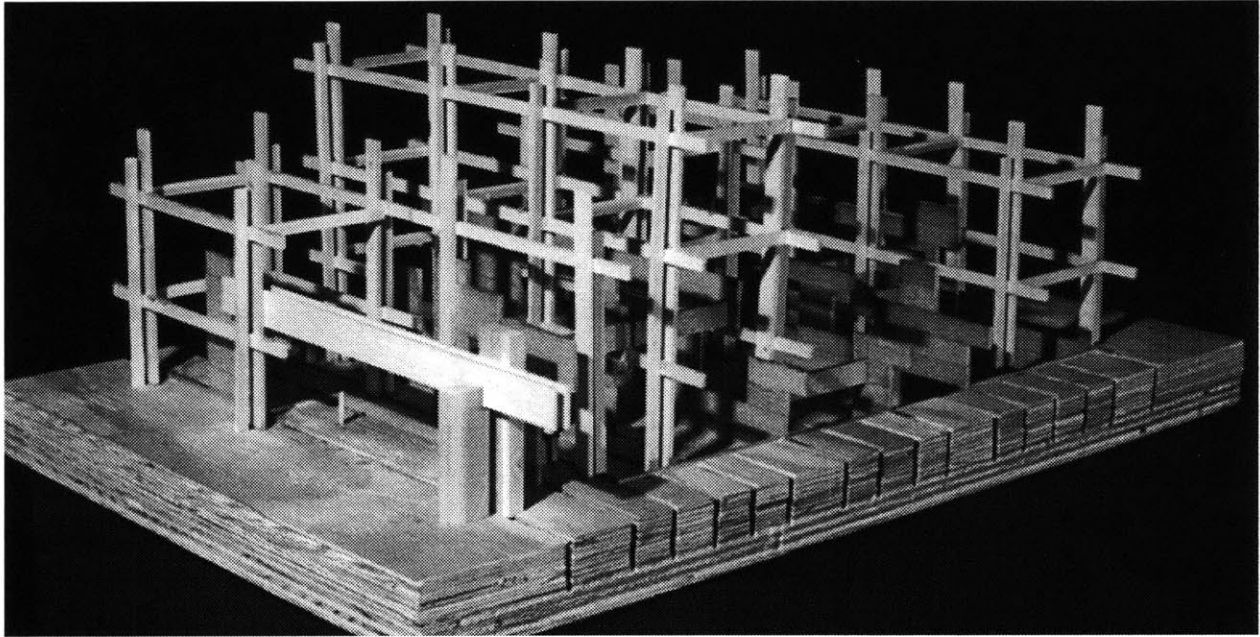

ILLUSTRATION SOURCES

All illustrations, unless otherwise noted, are by the author.

- Figure 1. Operation Breakthrough, p 17.
- Figure 8.1 Operation Breakthrough, p 230
- Figure 8.2 Schools: A system Approach, p 12
- Figure 9.1 Operation Breakthrough, p 26
- Figure 9.2 Operation Breakthrough, p 27.
- Figure 12 Traditional Architecture, p 54
- Figure 13 Traditional Architecture, p 55
- Figure 14 Next 21, p 8
- Figure 15.1 Next 21, p 9
- Figure 15.2 Next 21, p 9
- Figure 16 SD2 - February 1973, p 44
- Figure 17 SD2 - February 1973, p 45
- Figure 18.1 MKS Comic Book
- Figure 18.2 MKS Comic Book
- Figure 18.3 MKS Comic Book
- Figure 20 Prefabrication, p 152
- Figure 21.1 Prefabrication, p 175
- Figure 21.2 Prefabrication, p175
- Figure 23 <http://builderonline.com/builder/products>
- Figure 30 Aggregations, p 26
- Figure 32 R.M. Schindler, p 64
- Figure 34.1 R.M. Schindler, p 18
- Figure 36 Details for Modern Construction, p 127
- Figure 38 Dean Steel, Co. Pamphlet
- Figure 44 Charles Correa, p19
- Figure 46 Wachsman, et. al.
- Figure 50 Covintec, Inc. Pamphlet
- Page 63 MKS Final Review Notes.
- Figure 64 Iluustrators, p139
- Figure 79 Modern Steel in Euorpe, p 86
- Figure 80.1 Flexibility in Supports, p119
- Figure 80.2 Prefabrication, p 36
- Figure 81.1 Systems Building, p 27
- Figure 81.2 Large Panel Buildings, p 48
- Figure 81.3 Formwork for Modern Construction, p 66
- Figure 82 Montované Stavby, p 98
- Figure 83 Pu Pu Hot Pot, Fall 1995

BIBLIOGRAPHY with annotations

The following books, buildings, and articles have been enormously informative and helped my investigations this semester.

ALLEN, EDWARD. *Fundamentals of Building Construction: Materials and Methods - 2nd Edition*. New York: John Wiley & Sons, Inc., 1990. This reference book is a good tool for quick checks to standard detailing as well as an informative introduction to modern construction methods.

BÄCHER, MAX. *Walter M. Förderer, Architecture - Sculpture*. Switzerland: Editions du Griffon, 1975. Swiss architect Walter Förderer's work provides an understandable and richly varied example of a continuous surface vocabulary working primarily with cast in place concrete. The book contains full documentation of the building and design process, from sketches and models to working drawings and construction photographs, along with explanatory notes and criticism.

BORENSTEIN, DAVID. *Panel Assemblage for Housing: Some Form and Construction Explorations for Small Buildings*. M. Arch. Thesis: M.I.T. Department of Architecture, 1984. This thesis examines the consequences of building homes in a factory and explores viable construction alternatives using factory - made panels. The exploration considers panelized systems of dwelling construction and its ability to adapt to a variety of site conditions while providing a wide range of spatial options to the inhabitants (from the author's abstract).

BOWCENTUM/ ROTTERDAM. *Modern Steel Construction in Europe*. New York: Elsevier Publishing Co., 1963. A thorough discussion about steel construction in terms of material qualities and assembly techniques for a range of building systems through various sized - from bridges to structural frames to stairs and enclosure.

CABRÉ, ALBERTO. *Light and Culture: A Marketplace in the Old City of San Juan, Puerto Rico*. M. Arch. Thesis: M.I.T. Department of Architecture, 1997. This thesis is based on the author's awareness of trends toward globalization. He contends that these new building and new materials can be appropriate to a specific site if they react to and respect the environment: both physical and cultural.

DEPARTMENT OF HOUSING AND URBAN DEVELOPMENT. *Housing Systems Proposals for Operation Breakthrough*. Washington D.C.: U.S. Government Printing Office, 1970. A document listing different building system proposals for housing from hundreds of companies across the U.S. . The range includes everything from whole apartment modules to panelized building systems to individual material connection developments.

HALASZ, IMRE. *Aggregations: An Alternative Architectural Approach*. M.I.T. Architecture Design Studio. M.I.T. Department of Architecture, 1986. This booklet is a compilation from Professor in architecture Imre Halasz Spring, 1986 Design Studio. The studio examined using a large

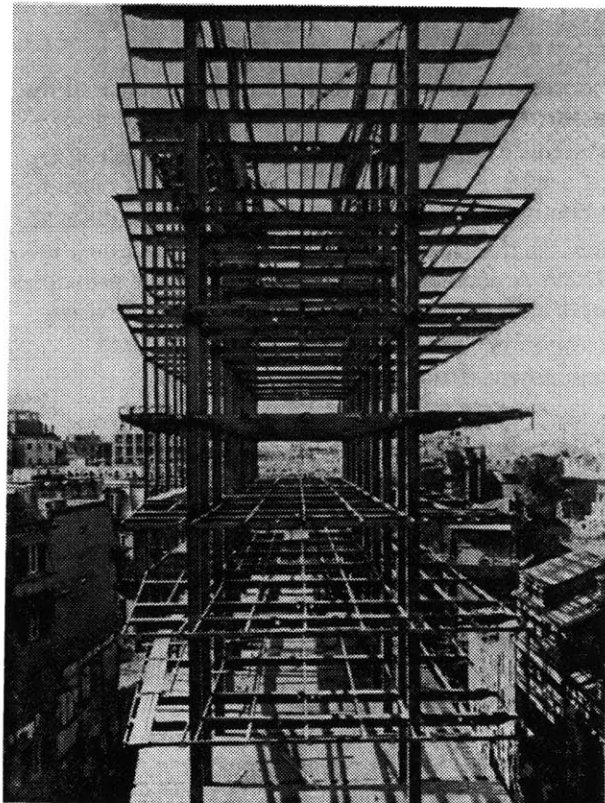

Figure 79. from *Modern Steel Construction in Europe*.

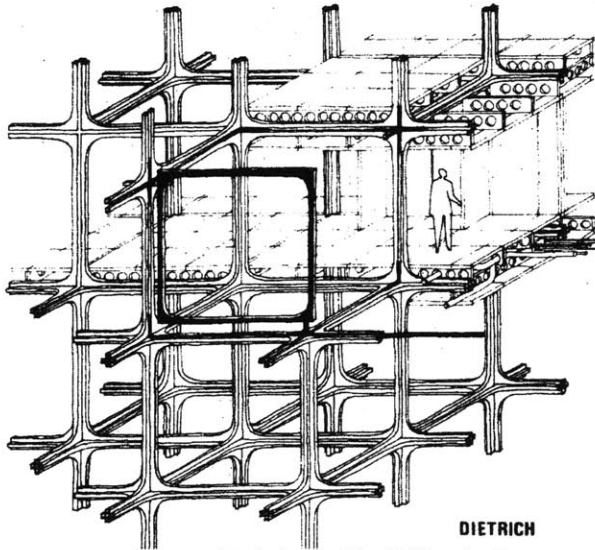

Figure 80.1 from *Flexibility in Supports*.

scale system to define Independent Development Zones (IDZs). These IDZs are then inhabited individually to varied and customized apartments. Issues of hierarchy - both spatial and structural - and organization of public and private are explicitly addressed.

HALLET, STANLEY. *Traditional Architecture of Afghanistan*. New York: Garland Publishing, Inc., 1980. The observations of Afghanistan houses in this book give a detailed sequence of the construction, showing how direct sequential systems assemblage has been employed in history.

HARRIS, FRANK. *Modern Construction Equipment and Methods*. New York: John Wiley & Sons, Inc., 1989. A detailed overview presenting the principles in deciding on methods of construction, devising temporary works, and selecting appropriate equipment (from the author's preface).

KHAN, HASAN -UDDIN. *Charles Correa*. Singapore: Concept Media Pte. Ltd., 1984. The professional work of Indian architect Charles Correa is documented in this book. Of particular interest is his use of building systems as independent and complementary elements of space. This is due in part to the specific climate's forgiveness of incomplete enclosure, but also to his ability to think about building in this way.

NUNNALLY, S. W.. *Managing Construction Equipment*. Englewood Cliffs, N.J.: Prentice - Hall, 1977. A good source of large equipment excavation techniques and illustrations.

OXMAN, ROBERT. *Flexibility in Supports: An Analysis of the Effect of Selected Physical Design Variables Upon the Flexibility of Support Type Housing Systems*. Ph. D. Dissertation: Israel Institute of Technology - Senate of the Technion, 1977. A survey of "support" type systems in housing practice with discussion as to strategies each employs. This doctoral thesis is an excellent catalog of distinct physical systems and directions being taken at its time.

PROUVÉ, JEAN. *Prefabrication: Structures and Elements*. New York: Praeger, 1971. Prouvé was one of the most proactive component prefabrication designers of his time, and his influence is found in much of the work done today by architects such as Norman Foster and Nicholas Grimshaw. One of the most important lessons, however, has been lost in that technological blitz: the prefabricated deployable structure. His school rooms and youth centers are both excellent examples of his "Jointed Frame Types."

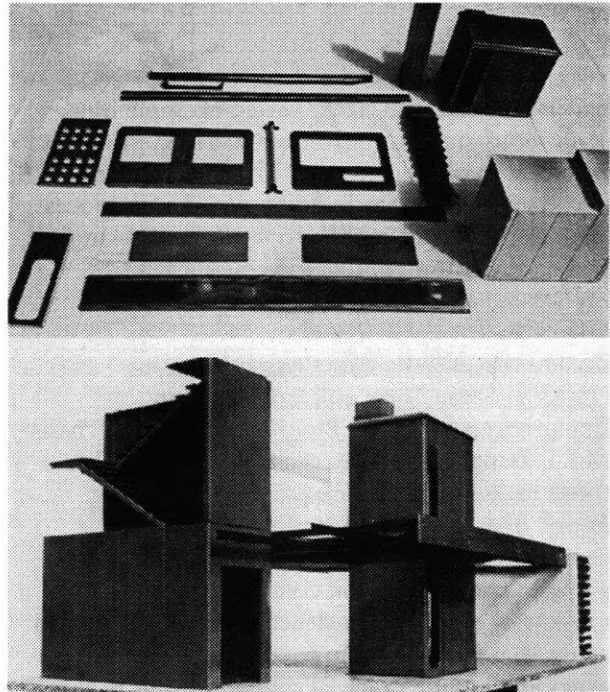

Figure 80.2 from Jean Prouvé.

SARNITZ, AUGUST. *R.M. Schindler, Architect*. Munich: Edition Christian Brandstätter, 1986. *German*. This book contains the widest range of illustrations and photographs of Schindler's work. The design and development of Schindler's systems, both building and organizational, can be clearly read.

SARNITZ, AUGUST. Rudolph M. Schindler, Theory and Design. M.S. Arch. Thesis: M.I.T. Department of Architecture, 1982. Sarnitz's thesis at M.I.T. compiles a history of Schindler's life and work, providing anecdotal and contextual information in the development of Schindler's theory.

SCHMID, THOMAS AND TESTA, CARLO. Systems Building: An International Survey of Methods. New York: Praeger, 1969. Written Much in the same vein as Operation Breakthrough (which it preceded), this book attempts to organize its systems by the connections and modules of the system components - moving toward what it refers to as "Total Architecture," and ending up with architects working for large scale industry as a component within the system. Whereas most system building construction discussions are exciting and evocative, this is almost depressing in its relentless, cellular repetition. It is included as an outstanding example of the enemy.

Sebestyén, Gyula. Large -Panel Buildings. Budapest: Akadémiai Kiadó, 1965. This book was a good source of sealing connections for prefabricated panels. The major focus of the books is in butted and clean - cornered connections, but the same principles can be easily applied to generate reasonable, territorial connections.

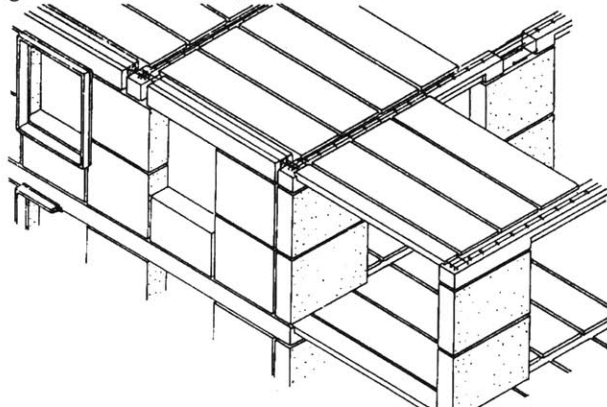

Figure 81.2 from Large-Panel Buildings.

SMITH, MAURICE. Fragments. M. Arch. Comic Book: M.I.T. Department of Architecture, 1995. A collection of published and unpublished notes, this handbook presents the work M.I.T. Professor in Architecture Emeritus Maurice Smith's practice and teaching. Obscurely self - referential and incomplete it remains, alas, the sole source of information from the pre-eminent architectural educator of the 20th century.

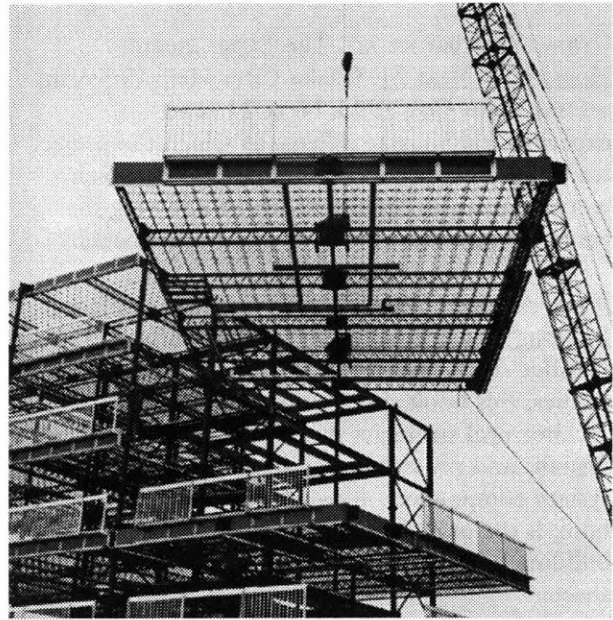

Figure 81.1 from Systems Building.

SVARC, BOHUMIL. Montované Stavby. Prague: Státní Nakladatelství Technické Literatury, 1960. Czechoslovakian. An excellent graphic library of various connections and steel placement for precast concrete building assembly.

SNOW, FREDERICK. Formwork for Modern Structures. London: Chapman and Hall, Ltd., 1965. This collection of treatises - the product of the Formwork Development Group - is an extensive encyclopedia of concrete formwork, both cast in place and precast. Of particular interest are the chapters dealing with column formwork and sliding formwork

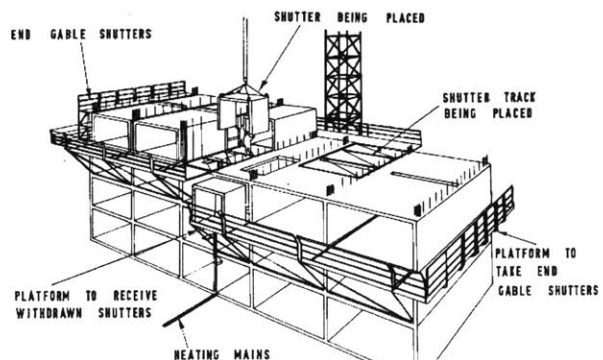
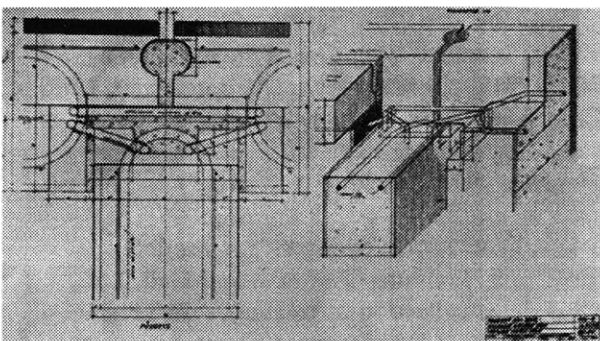

Figure 81.3 from Formwork for Modern Structures.

STUPRÉ (SOCIETY FOR STUDIES ON THE USE OF PRECAST CONCRETE). Konstruktion - Atlas: Precast Concrete Connection Details. Düsseldorf: Beton Verlag GmbH, 1978. This report on precast concrete connection has an exhaustive catalog of details and recommendations for building erection.

UTIDA, YOSITIKA ET. AL.. The Experimental Housing of Next 21. Osaka City: Meiji University + Osaka Gas Co., 1993. Next 21 is an experimental housing scheme in which the project team first built an overall building form which would remain as consistent whilst allowing for perpetual alterations to individual apartments.

WASS, ALONZO. Manual of Structural Details for Building Construction. Englewood Cliffs, N.J.: Prentice -Hall, Inc., 1968. Running through case studies, this book specifically addresses architectural strategies in choosing building systems and provides fully notated drawings of the system components. Also of great value in this book is the organization and formatting of building system catalogs and “technical data sheets.”



Obr. 171. Stěněnk tži panelu

Figure 82.1 from Montované Stavby.



5778-43

Specifications:

QuarkXPress 3.32
Adobe Photoshop 3.0.5

Sabon, 10 point
Universe, 12 point