

# **Matrix Hybridization in the Interlayer for Carbon Fiber Reinforced Composites**

**V. M. Drakonakis<sup>1,2,3</sup>, C. N. Velisaris<sup>1</sup> and J. C. Seferis<sup>1,\*</sup>, C. C. Doumanidis<sup>2</sup>, B. L. Wardle<sup>3</sup>,  
G. C. Papanicolaou<sup>4</sup>**

**1.** Polymeric Composites Laboratory, GloCal / F.R.E.E.D.O.M.,

3131 Western Ave M526, 98121, Seattle, WA, USA.

**2.** Mechanical and Manufacturing Engineering Dept., University of Cyprus,

75 Kallipoleos Avenue, P.O.Box 20537, Nicosia, 1678, Cyprus

**3.** Astronautics and Aeronautics Dept, Massachusetts Institute of Technology,

Bldg. 33-314, MIT, 77 Massachusetts Avenue, Cambridge, MA 02139-4307, USA

**4.** Mechanical Engineering and Aeronautics Dept., University of Patras,

Patras 26500, Greece.

\*To whom correspondence should be addressed

# Matrix Hybridization in the Interlayer for Carbon Fiber Reinforced Composites

V. M. Drakonakis<sup>1,2,3</sup>, C. N. Velisaris<sup>1</sup> and J. C. Seferis<sup>1,\*</sup>, C. C. Doumanidis<sup>2</sup>, B. L. Wardle<sup>3</sup>,  
G. C. Papanicolaou<sup>4</sup>

1.Polymeric Composites Laboratory, GloCal / F.R.E.E.D.O.M., Seattle, Washington, USA –  
2.Mechanical and Manufacturing Engineering Dept., University of Cyprus, Nicosia, Cyprus – 3.  
Astronautics and Aeronautics Dept, Massachusetts Institute of Technology, Cambridge,  
Massachusetts, USA – 4.Mechanical Engineering and Aeronautics Dept., University of Patras,  
Patras, Greece

## ABSTRACT

Polymeric composites have gone through a level of maturity beyond the laboratory stage with the development of the Boeing 787, the structure of which contains more than 50% composites. Nonetheless, a basic understanding of the material used in its primary structure has not been extensively investigated. For instance, micromechanical models are inadequate as they always assume an evenly distributed homogeneous matrix, without following classic lamination theory, which assumes constant stress through the laminate thickness. Our program now in its third year at the Polymeric Composites Laboratory in Seattle, supported by industry as well as government agencies, and in collaboration with several universities on a global scale, is developing such concepts for understanding and improving matrices in layered configurations. This effort focuses on the development of interlayer systems used as enablers to improve certain properties of the composite, such as fracture-toughness and crack-propagation inhibition.

KEY WORDS: Laminating, Matrices, Carbon-Fiber-Reinforced Polymers (CFRP), Interlayer, Hybrid

\*To whom correspondence should be addressed

# 1. INTRODUCTION

Both thermosets and thermoplastics are considered as potential materials used in matrices for advanced polymeric composites. Thermosetting systems are generally more preferable than thermoplastic ones, due to their advantageous processing which consists of prepreg tack and lower viscosity during the process [1]. Nevertheless, the thermosets used as matrices in polymeric composites were not able to provide the appropriate toughness capabilities in order to fulfill primary-structure applications requirements. The need for expanding the use of polymeric composites to commercial-aircraft primary structures has led to the toughening of thermosetting-resin systems as one of the most important objectives and has motivated essential research efforts. Many of those efforts are responsible for the development of a successful toughening technique suitable for primary structure applications that is based on layering concepts to form final multilayer laminate structures [2, 3].

This research focuses on the relationship investigation between multilayer structures and various thermosetting matrices in order to produce tougher polymeric composites with layering concepts. Overall, this work provides an understanding of the composites toughening by the application of layering concepts.

Ply delamination is the most serious damage within the laminate structure occurring when a composite material is tested for impact. Delamination causes increased degradation in the resulting composite mechanical properties [4]. In an attempt to impede delamination occurring during impact, a successful toughening technique for thermosetting-matrix composite systems, commercialized and qualified for use in primary structures, was developed [2, 3]. This toughening technique establishes an engineering approach to the toughness issue by using layering concepts for toughening the highly stressed interlaminar regions within the composite. Laminating is attained by using a tough resin-rich layer between the plies of the composite structure which eventually results to a multilayer laminate structure. These lamination

techniques can be implemented as heterogeneous or homogeneous modification, as schematically presented in Figure 1 [5], [14].

## **2. PROCESSING OF MULTILAYER STRUCTURED LAMINATES**

As extensively mentioned above, the need to exploit the benefits of thermosetting polymer-matrix composites in primary commercial airplane structures has led to the development of tougher multilayer thermosetting structures [2, 3].

This work focuses on the modeling of the interlayer-toughening concept with a second impregnation phase, hosted in three different resins. This second impregnation phase can be accomplished either through the development of a model multilayer composite structure containing a heterogeneous resin interlayer with rigid modifier particles or with a second-pass of resin only, developing a model multilayer structure containing a homogeneous resin interlayer.

In general, manufacturing of conventional high-quality composites consists of three main steps: prepreg processing, lay-up and autoclave processing. Making an effort to get a clear view of the multilayer structured composite process; its development is compared to the development of a conventional structure at each processing step as presented in Figure 2.

### **2.1 DOUBLE-PASS IMPREGNATION**

The difference between conventional prepreg and multilayer prepreg structures, either homogeneous or heterogeneous is shown schematically in Figure 2. The conventional prepreg has equally distributed reinforcing fibers within a matrix resin. Ideally, the prepreg has a constant thickness and the fibers have completely been wetted by the matrix resin. On the contrary, multilayer prepreg is generated by using a third component, the interleaf or the interlayer, which must be placed between each ply. Specific packing of the fibers must be performed to the toughened prepreg in order to accumulate the same resin as a conventional prepreg. The tighter fiber-packing accumulates less resin between fibers and allows for excess

resin to remain on the prepreg surfaces. Acquiring a fully impregnated structure with low resin content within fibers is another difficulty of the prepreg processing.

In processing of this multilayer prepreg structure, different techniques can be used depending on the kind of multilayer (heterogeneous or homogeneous).

### ***2.1.1 Heterogeneous Multilayer Structure***

There are two techniques that can be used in performing heterogeneous multilayer structures: sprinkling modifier particles on the prepreg surface or premixing modifier particles with resin to be applied during the prepreg process [8-10]. Consequently, a two-step prepreg process was developed, referred to as double impregnation, which was utilized to develop a model multilayer prepreg. In this double-pass impregnation step, the modifier particles were premixed with the same matrix resin that was applied during the first-pass impregnation step [6].

The purpose of conventional prepregging is to impregnate collimated fiber tows with a desired amount of matrix resin at elevated temperature and pressure in order to create a uniform, partially reacted lamina structure [2, 3]. Prepregging is a continuous process that consists of four basic operations. Firstly, the matrix-resin-film is created, then the coating, after that the impregnation zone, where heat and pressure are applied to the ply, and finally the prepreg, which is collected on a take-up reel [12, 13].

In heterogeneous structure, the modifier particle diameter is the factor that controls the amount of resin that will be applied during each impregnation step. The maximum diameter of the modifier particles can also be calculated, however more details on the calculation of the modifier particle diameter are given in the autoclave process, which is one of the following units. During the second impregnation, the thickness of the resin film is equal to the average modifier-particle diameter and thus, an almost monolayer particle distribution is obtained on the prepreg surfaces. Therefore, if the final prepreg fiber areal weight and resin content desired are known, the amount of resin that may be applied during the first impregnation can be given via [5]:

$$W_{r1st} = \frac{\left(\frac{A_f}{(1-W_r)} - A_f\right) - 2D_p P_r}{A_f + \left(\frac{A_f}{(1-W_r)} - A_f\right) - 2D_p P_r} \quad (1)$$

Where

$W_{r1st}$  = first-pass weight fraction resin

$W_r$  = final desired weight fraction resin

$A_f$  = areal weight, fibers [g/m<sup>2</sup>]

$D_p$  = average diameter of modifier particles [m]

$P_r$  = density of resin [g/m<sup>3</sup>]

### **2.1.2 Homogeneous Multilayer Structure**

As far as the double-pass impregnation in the homogeneous multilayer structure is concerned, a first-pass resin-starved step should be applied for pressing and packing the fiber bed. During the second-pass impregnation, the full thickness of the resin interlayer is applied creating a prepreg with overall normal desired resin content. However, the application of the interlayer is not the same as in the heterogeneous structure. In the heterogeneous structure the modifier particles of both surfaces of two different laminas that touch are intermingled and compressed with the final thickness of the interlayer equal to the diameter of the modifier particles. On the contrary, in a homogeneous prepreg structure applying an additional interlayer and then laminating will result in surplus overall resin content, thus reducing strength and stiffness.

As it is obvious from Figure 3, if the full thickness is applied to both sides of the fiber bed, more resin than the desired will be accumulated in the final matrix system. There are two possible methods of applying the interlayer and avoiding accumulation of more than the desired

resin. First, by applying half the thickness of the resin in the second-pass of the impregnation, a multilayer structure is achieved with the desired thickness of the interlayer without having more than the planned resin in the final matrix system. The second way of applying the interlayer is to enable it through one-sided impregnation. However, this may complicate the lay-up. Both techniques are schematically shown in Figure 4.

The amount of resin that may be applied during each impregnation step will be controlled by the maximum-thickness interlayer which can be determined. Its determination, however, will be given in detail in the section of autoclave processing, which follows further below. If the final prepreg fiber areal weight and resin content desired are known, the amount of resin that may be applied during the first impregnation can be given by the formula (1) [5], if the  $D_p$  is replaced by the maximum-thickness of the interlayer ( $T_i$ ).

Although heterogeneous multilayer structure can be used in composites in order to give a higher toughness between each ply, the homogeneous structure can be described as not so efficient for toughness improvement in composites. However, it can offer great toughness and high tack in hybrid materials, where a metal or other foil can be used instead of a single ply. The use of either a metal foil or any other ply as a single laminate to a composite material can be adjusted in a multilayer structure through homogeneous interlayers, by implementing to each ply the impregnation and setting the interlayer thickness, either half from both sides or full from one side. The layered structure can be further processed by traditional lay-up and autoclaving.

## **2.2 LAY – UP**

Lay – up follows the impregnation steps, where the desired shape is given and the anisotropic nature of each ply is taken into consideration. During the lay – up, prepreg tack is the overriding factor in prepreg performance. Prepreg must have the appropriate tack to consolidate each ply together; over-tacking may easily damage the prepreg in case a ply must be removed. Comparing the lay – up of a multilayer prepreg to a conventional one, a major

difference can easily be observed as it is presented in Figure 2. In a conventional prepreg lay – up, only a small amount of resin will separate the two plies. On the contrary, the toughened prepreg lay – up will contain two heterogeneous or two half homogeneous layers between each ply with one layer being supplied by each prepreg ply surface. The amount of resin located between the plies will directly affect the resulting prepreg tack. It is important for the multilayer prepreg structure that resin is accumulated on the prepreg surface [5]. If all the matrix resin has penetrated into the fiber bed, either modifier particles or nothing – depending if it is heterogeneous or homogeneous structure – will remain on the prepreg surface, which could create low-tack prepregs [11].

### **2.3 AUTOCLAVE PROCESSING**

The last step in composite manufacture is the autoclave. During this step, heat and pressure are applied in order to cure the laminate with a homeomorphous fiber distribution. In the case of a multilayer structured composite, on how the autoclave affects the resin distribution can be in detail described by Figure 2. The curing of a conventional composite causes resin flux, which develops a homeomorphous fiber with no distinct interface between the plies. On the contrary, the curing of the multilayer composite, although it also causes resin flux, it forms distinct layers as the modifier particles in the heterogeneous case and the second resin film in the homogeneous case are unable to penetrate into the fiber bed – due to the first-pass impregnation – and they are trapped between each ply. Eventually, the morphology contains layers of reinforcing fibers embedded in a matrix resin separated by resin – rich layers with a thickness that can be calculated. In the heterogeneous case, this interlayer contains twice the concentration of modifier particles that were initially placed on the prepreg surfaces. On the other hand, in the homogeneous case the desired resin is accumulated by placing only half of the resin thickness to each surface or full of it to one of the prepreg surfaces during the second impregnation step.



At this point, it should be mentioned that there are limitations of the maximum-thickness interlayer that can be used in processing. It is vital for manufacture to be able to calculate the thickness of the interlayer so that the resin content in total remains constant as in a single pass of a conventional prepreg. The maximum-thickness interlayer can be calculated as a function of the fiber areal weight, the final resin content and the maximum fiber-packing arrangement. As the fiber-packing becomes closer, the amount of resin required within each ply decreases and the amount of resin available for the interlaminar region increases. For the assumption that the maximum fiber-packing arrangement is assumed to be between a square array and a hexagonal-packed structure, as shown in Figure 5, the maximum-thickness interlayer can be given via [5]:

$$T_l = \frac{A_f \left( \left( 1 + \left( \frac{V_r}{V_f} \right) \right) \pi - 2(1 + \cos(\theta)) \right)}{p_f \pi} \quad (2)$$

Where

$A_f$  = fiber areal, weight [g/m<sup>2</sup>]

$T_l$  = maximum-thickness interlayer [m]

$V_r$  = resin volume fraction

$V_f$  = fibers volume fraction

$p_f$  = fiber density [g/m<sup>3</sup>]

$\theta$  = shift angle as defined in Figure 6 (for maximum effect  $\theta = 30^\circ$ )

As far as the heterogeneous case is concerned, the thickness  $T_l$  can be replaced by the maximum modifier particles diameter  $D_{pmax}$  [5]. Thus, the maximum modifier particle diameter

that can be used in the interlayer is defined. As for the homogeneous case, the maximum-thickness interlayer derives directly by formula (2).

### **3. TOUGHENING MECHANISMS OF MULTILAYER STRUCTURED LAMINATES**

Initial approaches to improve the toughness of thermosetting-resin systems comprised the blending of elastomers and/or thermoplastics to create a complete multiphase morphology. Firstly, significant improvements in toughness, by blending elastomers with epoxy, were demonstrated by McGarry and co-workers [16, 17]. In this approach, the final morphology of the cured resin consisted of continuous epoxy-rich phase surrounding discrete second-phase particles.

Toughness improvements up to a certain order of magnitude were acquired and ascribed to the second-phase particles fortifying the epoxies ability to yield and flow locally. Consequently, research carried on even further toughness improvements through the blending of elastomers with thermosetting matrices [18 – 21]. These investigations focused on the toughness improvement mechanisms in the elastomers-modified thermosetting systems.

Furthermore, toughness improvements are achieved by increasing the energy amount released during crack propagation. The need to meet the mechanical and temperature performance requirements of advanced polymer composites, researches changed over to the use of multipurpose epoxies blended with advanced thermoplastics such as polysulfones, polyethersulfones, and polyetherimides [22 – 25].

Regarding heterogeneous multilayer toughened laminates, modifier particles are constrained between the prepreg plies and are not derived by phase separation. Modifier particles consist of a separate phase throughout the entire laminate processing, even though their surface interaction may play a significant role in toughness enhancing. Additionally, due to their thermoplastic nature, modifier particles crystallize upon thermal processing over their glass

transition temperature and thus, they possess a relatively high modulus. Apart from observing fracture-toughness improvement, this work also focuses on investigating the fracture surfaces of model heterogeneous multilayer laminates in order to comprehend their toughening mechanisms from the matrix point of view.

#### **4. EXPERIMENTAL**

In order to investigate the role of the host resin matrix to the multilayer structure, three different model thermosetting-resin systems were utilized in the present study.

- First, an epoxy-based resin system was tested which was composed by: 60% tetraglycidyl-diaminodiphenylmethane (TGDDM) commonly known as MY – 720, 40% diglycidylether of bisphenol A (DGEBA) commonly known as Epon 828, 10 parts per hundred parts epoxy (phr) polyethersulfone (PES) commonly known as Victrex 5003P, and 42 phr diaminodiphenylsulfone (DDS) curing agent as HT 976 Hardener. The described materials are now available by Huntsman. The epoxy model system is presented in figure 6.
- Second, a dicyanate-based resin system was tested which was composed by: AROCY M-20 dicyanate and 5% by weight P1800 polysulfone. Polysulfone was blended with the dicyanate matrix system before the catalyst was added at 160 °C for 45 minutes and was soluble in the uncured dicyanate resin. The AROCY M-20 dicyanate system possesses room temperature viscosity of about 2E4 Poise, which creates a very difficult prepreg processing due to high tack of final prepreg. Polysulfone was mixed with dicyanate resin system for elevating its viscosity and enhance the prepreg handling characteristics. The described materials are now available by Huntsman. Chemistry of the dicyanate model system is presented in figure 6.

- Finally, a bismaleimide (BMI)-based resin system keramid 70023 was examined. The BMI resin systems were easily processable with a minimum viscosity of approximately 2 Poise. The BMI materials are now available by Huntsman.

The epoxy, dicyanate and BMI resin systems were chosen due to the fact that they represent the temperature and the toughness capabilities width for the most of the thermosetting-resin systems. Typically, BMI is more brittle than epoxy which is more brittle than dicyanate. As far as the heterogeneous structure is concerned, in all resin systems, a model system of semi-crystalline Nylon 6 modifier particles, now available from Toray, was used. The Nylon 6 modifier particles had an average particle diameter of 20  $\mu\text{m}$  or 40  $\mu\text{m}$ . The modifier particles were mixed with the base resin systems and applied during the impregnation processing (double-pass impregnation). Regarding the homogeneous structure, the use of a homogeneous interlayer in order to lay up even plies of different material is under investigation.

#### **4.1 PROCESSING**

The prepreg samples during the process had a fiber areal weight of 255  $\text{g}/\text{m}^2$  and final resin contents of 35% resin by weight. The reinforcing carbon fibers for all prepreps came in 12K tows Toray T800HB. The areal weights of the modifier particles that were applied during the second impregnation to the prepreg surfaces were measured with an acetone extraction procedure. According to this procedure, the resin films produced during the second impregnation process were washed with acetone through a vacuum-filtration apparatus. The base resin was soluble in the acetone and passed through the filter paper, while the modifier particles were not soluble in the acetone and was filtered out. Filter paper's weight increase was close to the particles weight applied to the prepreg surfaces. Then the modifier particle areal weight can be given by dividing it by the length and width of the resin film via [5]:

$$A_p = \frac{W_p}{L_f W_f} \quad (3)$$

Where:

$A_p$  = modifier particle areal, weight [g/m<sup>2</sup>]

$W_p$  = modifier particle weight in resin film [g]

$L_f$  = resin film, length [m]

$W_f$  = resin film, width [m]

## 4.2 FRACTURE-TOUGHNESS TESTING

In order to perform the fracture-toughness testing, a screw-operated Instron mechanical testing machine, Model 4505, was utilized. Mode I interlaminar fracture-toughness testing was through Double Cantilever Beam (DCB) samples and Mode II interlaminar fracture-toughness testing was through End Notch Flexure (ENF) specimens. Both DCB and ENF samples are schematically shown in figure 7.

The Mode I fracture-toughness was calculated with linear-elastic fracture mechanics using an area method via [6]:

$$G_{IC} = \frac{\Delta A}{w \Delta a} \quad (4)$$

Where:

$G_{IC}$  = Mode I critical strain energy-release rate [J/m<sup>2</sup>]

$\Delta A$  = difference in area under adjacent load/displacement curves [J]

$w$  = width of fracture sample [m]

$\Delta a$  = increase in crack length [m]

The Mode II fracture-toughness was calculated from elastic beam theory via [6]:

$$G_{IIc} = \frac{9a^2 P^2 C}{2w(3a^3 + 2L^3)} \quad (5)$$

Where:

$G_{IIc}$  = Mode II energy-release rate [ $J/m^2$ ]

$a$  = crack length [m]

$P$  = maximum load [N]

$C$  = sample compliance [ $Pa^{-1}$ ]

$w$  = sample width [m]

$L$  = distance between central load and support [m]

## 5. RESULTS AND DISCUSSION

### 5.2 MODE I AND MODE II TESTING

Figure 8 presents the comparison of Mode I interlaminar fracture-toughness between the dicyanate and epoxy model systems. The BMI model system  $G_{IC}$  results are not included due to a very high void content in the samples and poor fracture-toughness results. The comparison of the epoxy and the dicyanate system structured laminates with the 0% modifier particles in the interlayer gives a  $G_{IC}$  of  $300 J/m^2$  compared to  $550 J/m^2$ , respectively. After the multilayer structure creation, the dicyanate system shows a slight decrease in  $G_{IC}$  values similar to the results observed with the epoxy resin system. Furthermore, the dicyanate results show that the multilayer structure creation produces no improvement in the Mode I interlaminar fracture-toughness.

Figure 9 presents the comparison of Mode II interlaminar fracture-toughness in the three resin model systems. Conventional structure laminate results demonstrate that the dicyanate is the toughest resin system and BMI is the most brittle with  $G_{IIc}$  unmodified values of 800, 500 and 250 J/m<sup>2</sup> dicyanate, epoxy and BMI respectively. All three systems show dramatic improvements in  $G_{IIc}$  with a maximum occurring for each system that shift towards higher concentrations as the host resin toughness increases. When crack propagation moves from the interlaminar region to the intralaminar region, a maximum  $G_{IIc}$  occurs.

## 5.1 INTERLAYER TOUGHNESS MECHANISMS

Mode II interlaminar fracture surfaces of heterogeneous multilayer toughened laminates were evaluated by scanning electron microscopy (SEM). The big difference of Mode II compared to Mode I fracture surfaces can be easily observed in traditional thermosetting matrices by the large difference in fracture surface roughness due to hackle formation, which are formed by the shear stresses acting on the resin system (figure 10 (B)). The toughening mechanisms observed in this work are also presented schematically in figure 10 (A).

Determining a baseline Mode II fracture surface, an unmodified epoxy laminate with a conventional final morphology was examined in SEM. Figure 11 (A) and (B) presents the fracture surfaces in both low and high magnification respectively. The rough surface acquired by the Mode II testing is demonstrated in the low-magnification figure, while the high-magnification figure clearly demonstrates the hackle formation. In Mode II, as resin toughness increases hackle spacing decreases. The Mode II fracture surface of an epoxy multilayer laminate with 25% modifier particles by volume is presented in figure 12 (A) and (B) in both low and high magnification respectively. As the magnification increases, hackles can be observed, however the surface is partly dominated by a considerable amount of highly deformed matrix. At low-magnification, holes also appear in the resin system, where modifier particles may have debonded during the fracture testing. The additional deformation in the resin system must occur

due to the modifier particles incorporation and it appears to be yielding of the actual modifier particles.

The epoxy heterogeneous multilayer laminates at a higher volume content of modifier particles (44%) are presented in figure 13 in different magnifications. The matrix resin presents an overall rougher morphology. Nevertheless, at higher magnifications (figure 13 (B)), the larger amount of matrix deformation occurring between the hackles with the modifier particles concentration increase is easier to be detected. This deformation occurs at the modifier particle surface suggesting good bonding between the particles and the matrix system forming a modifier particle yielding and debonding failure mechanism. Further magnification increase (figure 13 (C)), demonstrates the rough modifier particle surface between hackles.

In dicyanate laminates fracture surfaces examination by SEM, a similar morphology to the epoxy fracture surfaces is observed with one clear difference, phase separation of polysulfone. This polysulfone phase separation can be seen in figure 14 (A) where round modules are observed in the base resin system. This phase separation occurred while curing and it has been previously observed in dicyanate matrix systems by Shimp and co-workers [26]. In terms of fracture morphology, the modifier particle surface deformation can be seen in figure 14 (B). Similarly with the epoxy matrix system, this fracture-toughness suggests that the same failure mechanisms occur with modifier particle yielding and debonding.

Compared to the other two matrix systems, BMI heterogeneous multilayer laminates exhibited significant differences. Figure 15 (A) and (B) present BMI Mode II fracture surfaces at low and high magnification respectively. At low-magnification a very little hackle formation is observed in spite of the large number of holes seen in the matrix. Higher magnification examination (figure 15 (B)) verifies that there is a large number of holes where modifier particles had been located. Toughness improvements in BMI system seem to only be due to crack-deflection, which increases the crack path distance. Modifier particles did impose crack propagation, although there was weak adhesion to the resin system.



### 5.3 TOUGHNESS IMPROVEMENT

The comparison of ENF results for the three model systems demonstrates that the host resin base toughness plays an important factor in the final layered structure toughness. Dicyanate, which is the toughest resin system, has the toughest multilayer laminate. BMI, which has the least tough resin system, has the least tough multilayer laminate. By plotting the ENF results as a percent  $G_{IIC}$  improvement in Figure 16, it is interesting to mention that all three systems present similar improvements in toughness. BMI produced a maximum improvement of 80%, epoxy produced an improvement of 118% and dicyanate produced a maximum improvement of almost 100%. BMI  $G_{IIC}$  improvement may be slightly lower and this could be attributed to voids in the fracture samples.

Despite the fact that the toughness improvements of the three systems are similar, the maxima do not occur at the same modifier particles content levels. The BMI maximum occurs at 21% modifier particles, the epoxy maximum occurs at 36% modifier particles and the dicyanate maximum occurs at 42% as presented in Figure 16. Consequently, the more brittle the resin system the lower the maximum concentration of modifier particles required to obtain similar toughness improvement.

Observing the similar percent in  $G_{IIC}$  improvements for all host resin systems, it can be seen that there is a maximum ratio of interlaminar fracture-toughness to intralaminar fracture-toughness that cannot be exceeded. If the interlaminar fracture-toughness is too high, crack propagation moves from a high toughness interlaminar region to a low toughness intralaminar region. Therefore, if the conventional Mode II fracture-toughness of a thermosetting matrix composite is known, the maximum toughness capability of that system can be predicted by defining a toughness capability ratio via [7]:

$$T_c = \frac{G_{IICml}}{G_{IICcon}} = 2 \quad (6)$$

Where:

$T_c$  = toughness capability

$G_{IIc_{ml}}$  = maximum  $G_{IIc}$  of multilayer laminate

$G_{IIc_{con}}$  =  $G_{IIc}$  of conventional laminate

This toughness capability of 2 may only be valid for the modifier particles used in this work. Higher toughness capability ratios may be obtained through the optimization of modifier particle shape, size distribution and interaction with the host resin matrix. Homogeneous multilayer structures have also to be tested and compared with the modifier particles results.

## 6. CONCLUSIONS

The toughness of heterogeneous multilayer laminates is strongly dependent on the host resin matrix resin. The larger base resin toughness corresponds to the toughest final laminate. Nevertheless, the percentage increase of  $G_{IIc}$  due to the creation of the multilayer structure is independent of the base resin toughness. The maximum toughness improvements for all systems examined was approximately 100%.

Furthermore, the observed toughness improvements correlate directly to the location of crack propagation during testing. If crack propagation occurs in the interlaminar region, toughness improvements can be expected. But if the crack moves into the intralaminar region, toughness degrades. Consequently, the amount of toughness improvement must be balanced between interlaminar and intralaminar fracture-toughness.

Examination of Mode II interlaminar fracture surfaces of the heterogeneous model structured laminates were evaluated with SEM. The non-modified laminate presented typical Mode II hackled surface. In the epoxy and dicyanate matrix systems, the incorporation of the modifier particles led to rougher fracture surfaces among hackles that can be ascribed to particles yielding and debonding. On the other hand, in BMI laminates, weak bonding between

the modifier particles resulted in the presence of empty holes in the fracture surface. Therefore, the modifier particles only served to deflect the fracture path. Summarizing, the toughening mechanisms in the multilayer systems, crack deflection, particle stretching and debonding were observed. The interaction of the modifier particles with the host matrix system and their importance in the failure mechanisms were demonstrated.

Finally, this work has demonstrated that even though the multilayer structured laminates provide Mode II interlaminar fracture-toughness improvements, their mechanical testing behavior is extremely different than conventional composite structures. Continuous understanding of the fundamental differences in process, structure and properties between multilayer and conventional prepregs is essential for improved utilization in load-bearing structural applications of composites.

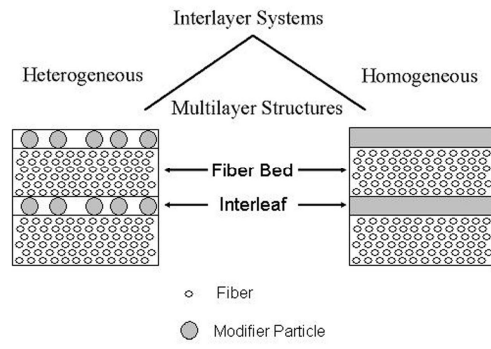
## **7. ACKNOWLEDGEMENTS**

Support for this work was provided in part by the Air Force Office of Scientific Research (AFOSR) and partnerships through the BEDR Global Group Network of profit and not-profit organizations at the Polymeric Composites Laboratory formerly at the University of Washington and now part of GloCal / F.R.E.E.D.O.M. in Seattle, Washington.

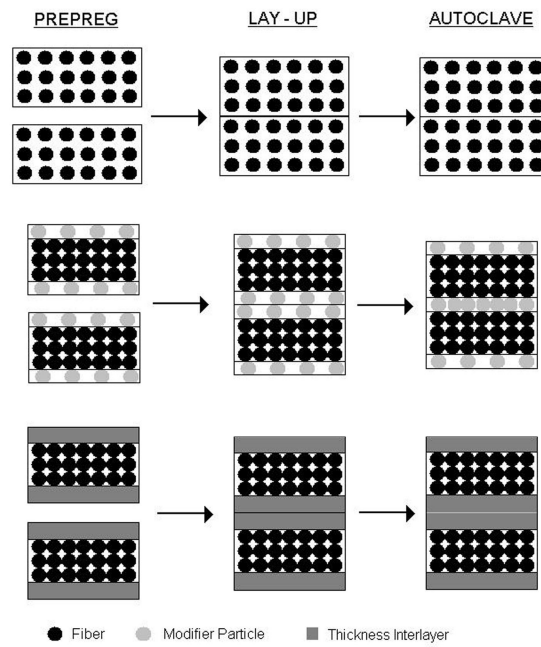
## 8. REFERENCES

- 1) *Engineered Materials Handbook* Volume 1: Composites, published by ASM International, (1987).
- 2) J. D. Boyd, *U.S. Patent* 5,037,689 (1991).
- 3) T. Folda, J. D. Boyd, H. Tesch, T. Weber, H. G. Recker, *U.S. Patent* 5,242,748 (1993).
- 4) K. R. Hirschbuehler, *SAMPE Quarterly*, **17**, (1), pp. 46-49 (1985).
- 5) M. A. Hoisington and J. C. Seferis, *SAMPE Quarterly*, **24**, (2), pp 10-20, (1993).
- 6) M. A. Hoisington, and J. C. Seferis, *Proceedings of 6th Technical Conference of American Society for Composites*, pp 53-62 (1991).
- 7) M. A. Hoisington, Ph.D. Dissertation, Department of Chemical Engineering, University of Washington: Seattle, (pp 2, 51, 94), (1992).
- 8) N. Odagiri, S. A. Suzue, H. Kishi, T. Nakae, A. Matsuzaki, *European Patent* 0,274,899 (A2) (1988).
- 9) N. Odagiri, S. Suzue, A. Matsuzaki, H. Kishi, T. Nakae, *U.S. Patent* 5,789,073 (1998).
- 10) J. E. Brown, N. Natsume, N. Odagiri, J. J. Hawkey, B. S. Hayes, *U.S. Patent* 7,208,228 (2007).
- 11) J. W. Putnam, B. S. Hayes, J. C. Seferis, *Journal of Advanced Materials*, **27**, (4), pp. 47-57, (1996).
- 12) B. S. Hayes, J. C. Seferis, E. Anderson and J. Angal, *Journal of Advanced Materials* **28** (4), pp. 20-25 (1997).
- 13) S. Zeng , M. A. Hoisington and J. C. Seferis, *Polymer Composites*, **14**, (6), pp. 458-466 (1993).
- 14) E. N. Gilbert, B. S. Hayes, J. C. Seferis, *Composites Part A: Applied science and Manufacturing*, **34**, (3), pp. 245-252, (2003).

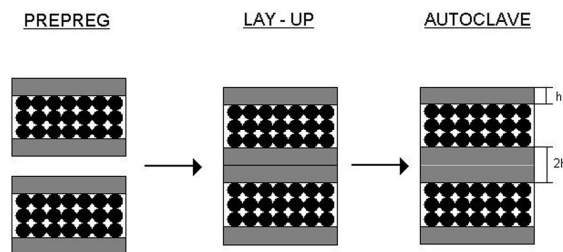
- 15) W. X. Wang, , Y. Takao, T. Matsubara and H. S. Kim, *Composites Science and Technology*, **62**, (6), pp. 767-774, (2002).
- 16) J. N. Sultan, R. C. Laible, F. J. McGarry, *Applied Polymer Symposium*, **16**, pp. 127-136 (1971).
- 17) J. N. Sultan and F. N. McGarry, *Polymer Engineering and Science*, **14**, (4), pp. 282-287 (1974).
- 18) A. F. Yee and R. A. Pearson, *Journal of Materials Science*, **21**, (7), pp. 2462-2474 (1986).
- 19) R. A. Pearson and A. F. Yee, *Journal of Materials Science*, **21**, (7), pp. 2475-2488 (1986).
- 20) A. C. Garg and Y. W. Mai, *Composites Science and Technology*, **31**, (3) pp. 179-223 (1988).
- 21) R. A. Pearson and A. F. Yee, *Journal of Materials Science*, **24**, (7) pp. 2571-2580 (1989).
- 22) L. Jayle, C. B. Bucknall, I. K. Partridge, J. N. Hay, A. Fernyhough, I. Nozue, *Polymer*, **37**, (10), pp. 1897-1905 (1996).
- 23) B. S. Hayes, J. C. Seferis, *Journal of Composite Materials* **36**, (3), pp. 299-312 (2002).
- 24) R. W. Hillermeier, J. C. Seferis, *Composites Part A: Applied Science and Manufacturing* **32**, (5), pp. 721-729 (2001).
- 25) C. B. Bucknall and A. H. Gilbert, *Polymer*, **30**, (2) pp. 213-217 (1989).
- 26) D. A. Shimp, J. R. Christenson and S. J. Ising, *34<sup>th</sup> International SAMPE Symposium*, pp. 222-233, (1989).



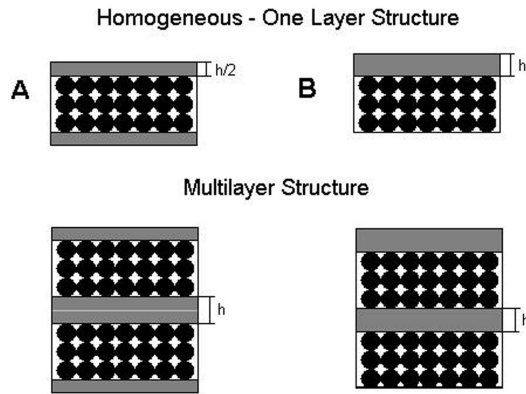
**Figure 1: Heterogeneous and Homogeneous Approaches to the Layer Toughening Concept [4]**



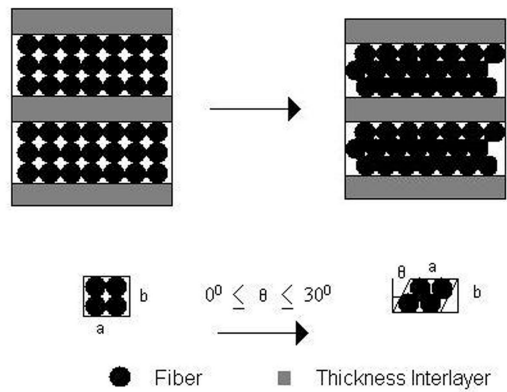
**Figure 2: Development of Conventional and Multilayer Structured Composites [4]**



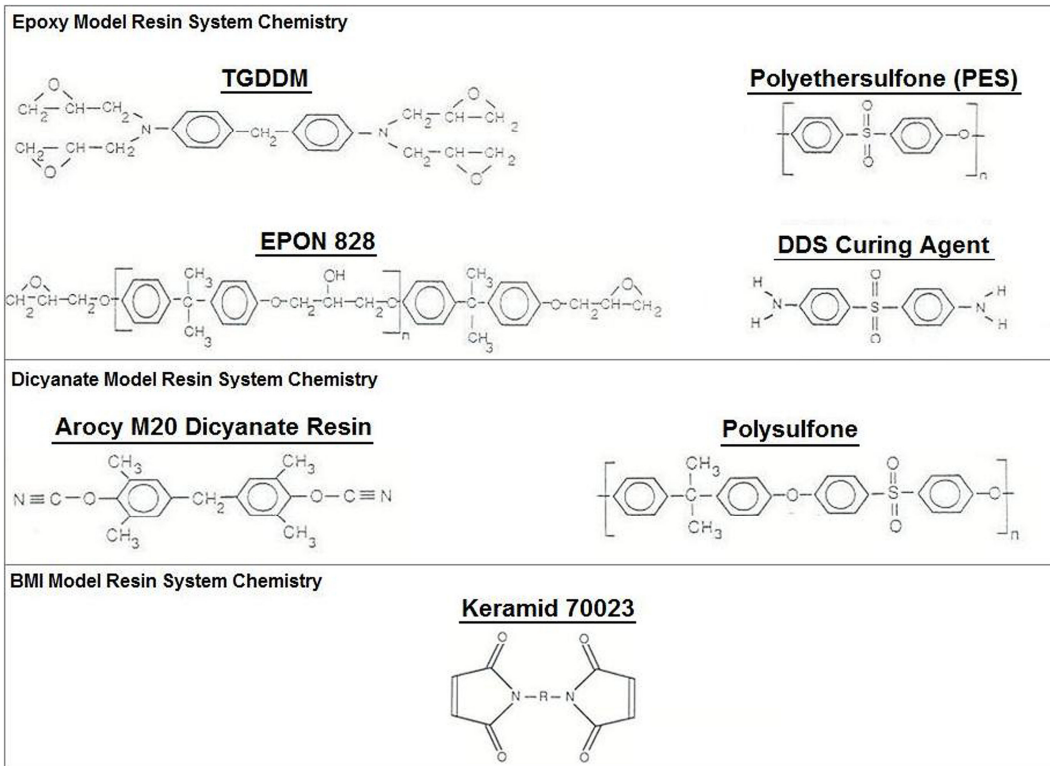
**Figure 3: Second-pass of impregnation**



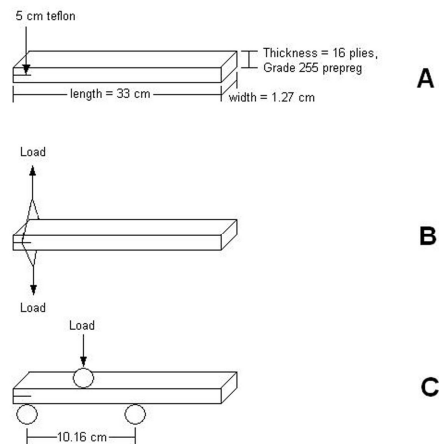
**Figure 4: Two different ways for applying the homogeneous interlayer: (A) Applying half the thickness of the resin in the second-pass of the impregnation, (B) Applying full the thickness of the resin only on one side of the fiber bed in the second-pass of the impregnation.**



**Figure 5: Schematic of Fiber-Packing Arrangements with the homogeneous interlayer implemented. Maximum packing achieved at  $\theta = 30^\circ$  [4]**

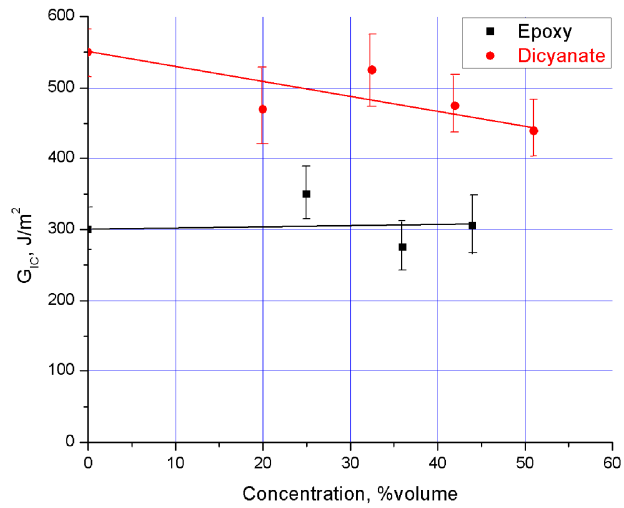


**Figure 6: Epoxy, Dicyanate and BMI Model Resin Systems**

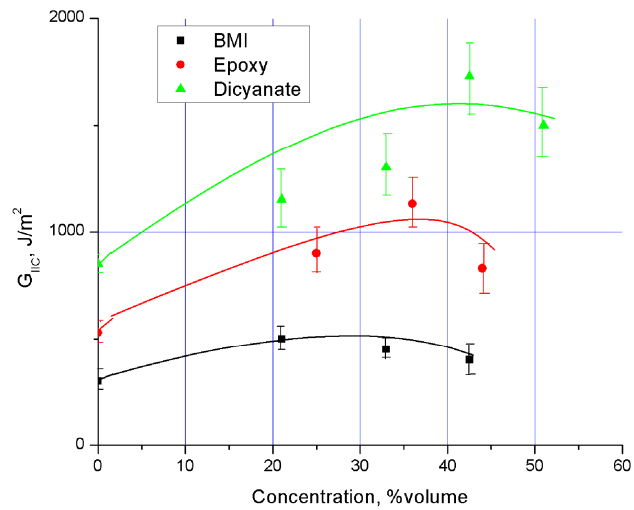


**Figure 7: Fracture-Toughness Configurations: A) Specimen dimensions, B) Double Cantilever Beam Testing and C) End Notch Flexure Testing [5]**





**Figure 8: Mode I Interlaminar Fracture-Toughness ( $G_{IC}$ ) Comparison of Epoxy and Dicyanate - Based Model Systems as a function of Modifier Particle Concentration in Interlayer**



**Figure 9: Mode II Interlaminar Toughness ( $G_{IIc}$ ) Comparison of Epoxy, Dicyanate and BMI -Based Model Systems as a function of Modifier Particle Concentration in Interlayer**

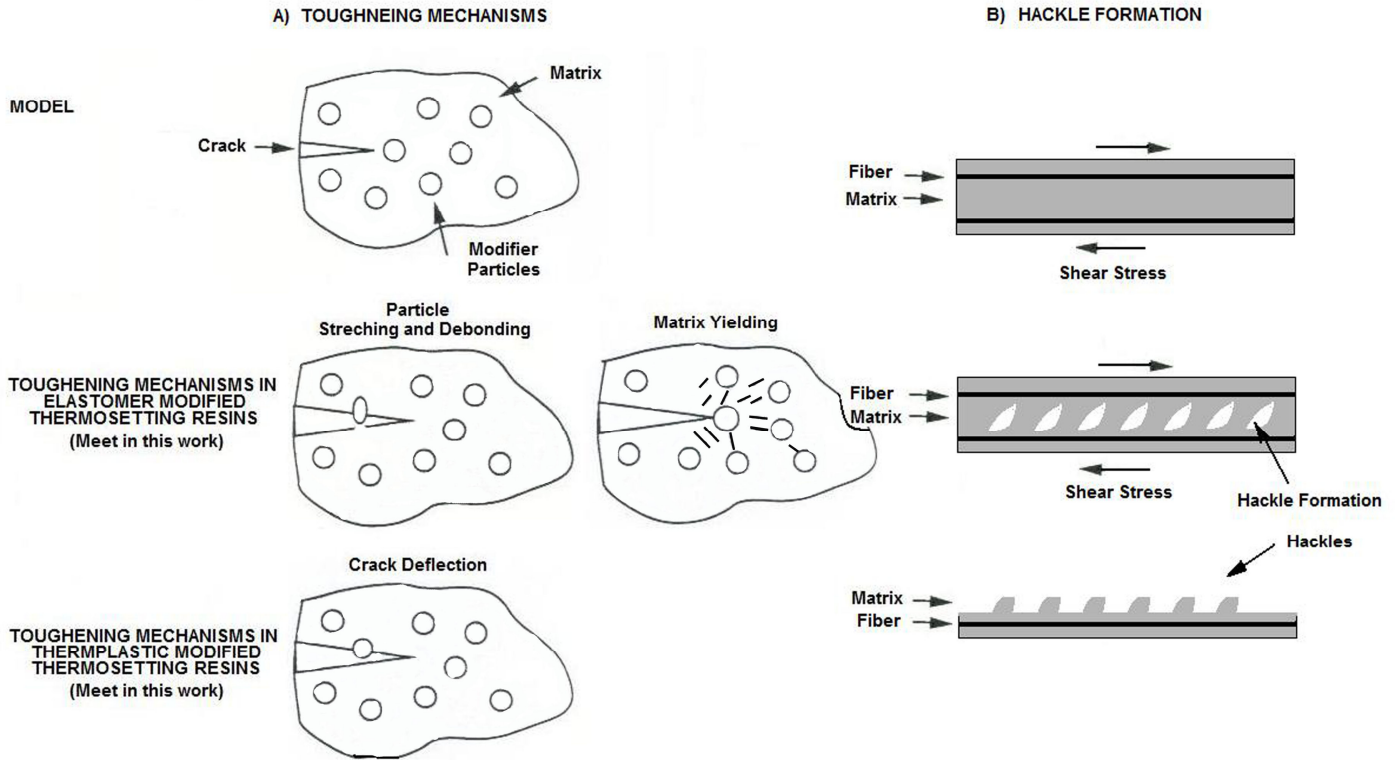


Figure 10: A) Toughening Mechanisms observed in present work, B) Hackle Formation

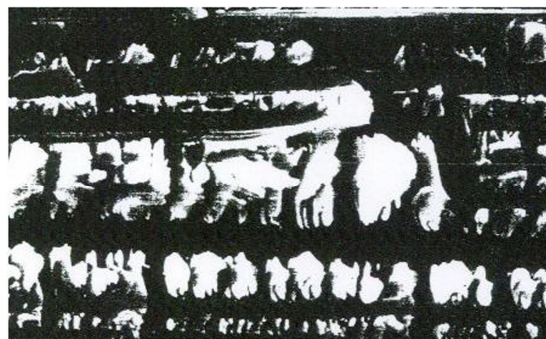
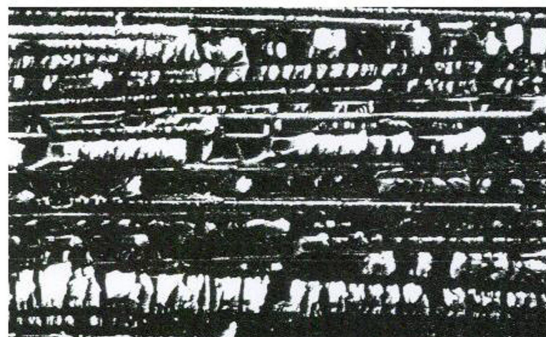


Figure 11: SEM of Mode II Fracture Surfaces of Conventional Epoxy Laminates at A) Low and B) High Magnifications

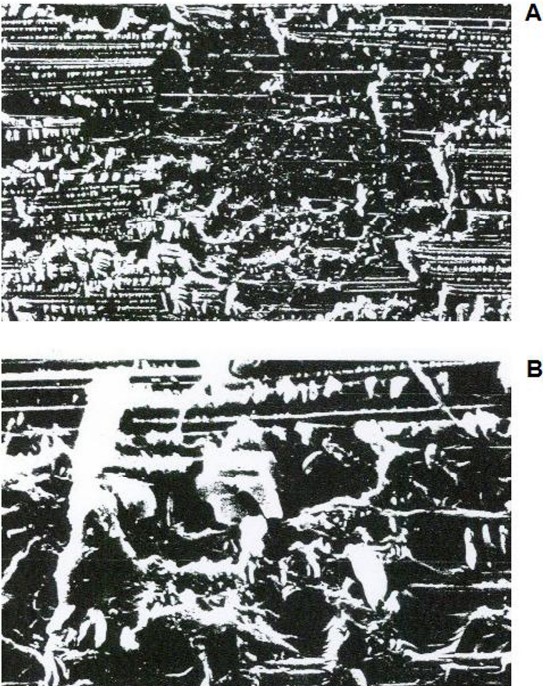
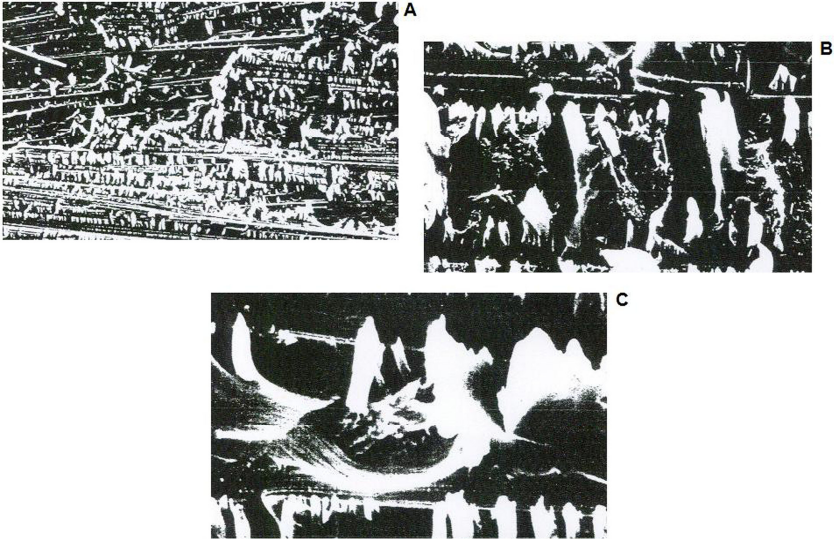
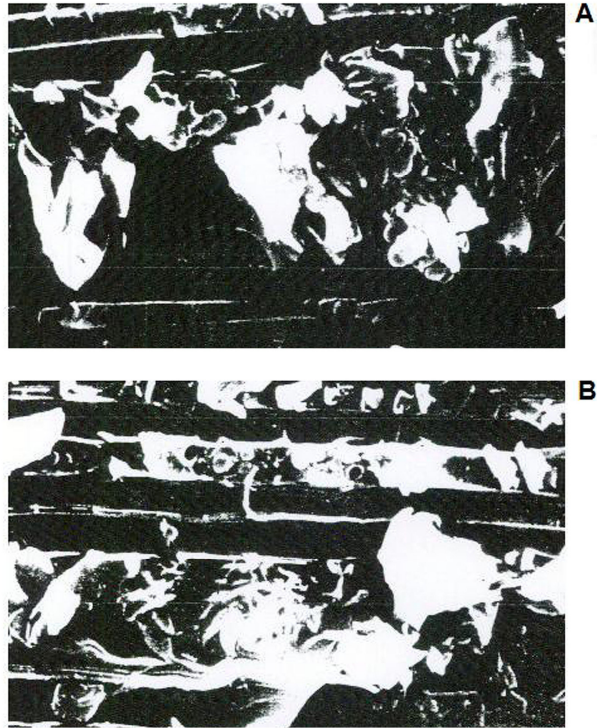


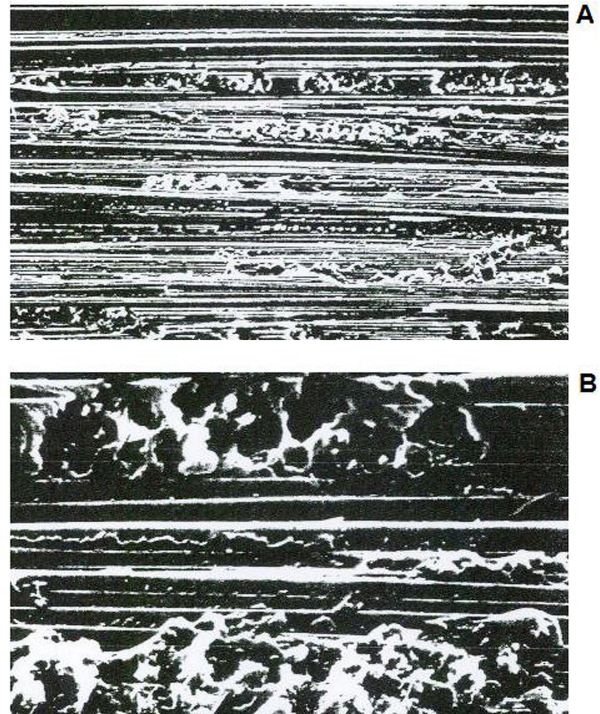
Figure 12: SEM of Mode II Fracture Surfaces of Model Epoxy Laminate with 25% Modifier Particles at A) Low (x200) and B) High (x750) Magnifications



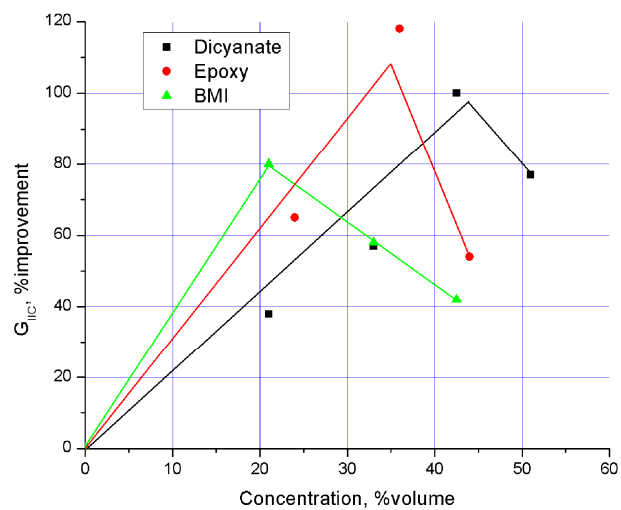
**Figure 13: SEM of Mode II Fracture Surfaces of Model Epoxy Laminate with 44% Modifier Particles at A) Low (x200), B) High (x1000) and C) Higher (x3000) Magnifications**



**Figure 14: SEM of Mode II Fracture Surfaces of Model Dicyanate Laminate with 33% Modifier Particles at A) and B) at Same Magnification**



**Figure 15: SEM of Mode II Fracture Surfaces of Model BMI Laminate with 21% Modifier Particles at A) Low (x150) and B) High (x750) Magnifications**



**Figure 16: Percent Mode II Interlaminar Fracture-Toughness Improvement of Epoxy, Dicyanate and BMI Model Systems as a function of Modifier Particle Concentration in Interlayer**