

BE-ing Default: The Morphosyntax of Auxiliaries

by

Bronwyn Alma Moore Bjorkman

B.A., Linguistics and Philosophy, McGill University, 2006

Submitted to the Department of Linguistics and Philosophy
in partial fulfillment of the requirements for the degree of

Doctor of Philosophy

at the

MASSACHUSETTS INSTITUTE OF TECHNOLOGY

September 2011

© Massachusetts Institute of Technology 2011. All rights reserved.

Author
Department of Linguistics and Philosophy
September 2, 2011

Certified by.....
Sabine Iatridou
Professor of Linguistics
Thesis Supervisor

Accepted by.....
David Pesetsky
Professor of Linguistics
Chair of the Linguistics Program

BE-ing Default: The Morphosyntax of Auxiliaries

by

Bronwyn Alma Moore Bjorkman

Submitted to the Department of Linguistics and Philosophy
on September 2, 2011, in partial fulfillment of the
requirements for the degree of
Doctor of Philosophy

Abstract

This dissertation is concerned with the broad question of why auxiliary verbs occur in natural language. Much previous work has assumed that the occurrence of auxiliary verbs is morphologically or syntactically *arbitrary*. I argue instead that auxiliary verbs, particularly BE, arise as a result of general properties morphological and syntactic systems of verbal inflection.

More specifically, I propose that the existence of auxiliary BE reflects the fact that the inflectional system can fail to unite inflectional material with a main verb. I argue the reasons for this failure are *structural*: inflectional information combines with the main verb via Agree (Chomsky, 1998), a process constrained by relativized locality. Certain inflectional contexts *isolate* inflectional features from the verb because other targets for inflectional Agree intervene between them, resulting in these features being *stranded*. Stranded features are morphologically realized separately from the main verb; if they are affixal, this triggers the insertion of a totally default verb (BE) within the morphological component. Framing this approach to inflection in terms of Agree, however, requires modification of Chomsky's original formulation, so that inflectional feature values can be passed *downward* (or fail to be passed downward) from functional heads onto the main verb. I argue for a "reverse" formulation of Agree similar to that adopted in a number of recent papers (Baker 2008, Zeijlstra 2010, Wurmbrand 2011, a.o.)

The resulting framework for verbal inflection predicts that different patterns of auxiliary use arise cross-linguistically due to differences in which inflectional features are able to Agree locally with the main verb. I argue that this variation can be traced two factors independently known to differ cross-linguistically: inflectional feature *markedness*, determining which features are visible to Agree, and the distribution of head movement, able to move the verb into local relationships with higher functional heads.

Subsequent chapters extend this general approach into a variety of related domains: the alternation between HAVE and BE in auxiliary selection, the conflict between this analysis of BE and the traditional analysis of DO-support as a process that rescues stranded inflection, and the interaction of verbal inflection and auxiliaries with counterfactual inflection marking.

Thesis Supervisor: Sabine Iatridou

Title: Professor of Linguistics

*In memory of my Nana,
Gertrude Theora "Sully" Moore.*

*Whence auxiliaries?
If they are stranded features,
many things follow.*

Acknowledgements

It's difficult to believe that the time has arrived to write the acknowledgements for my dissertation. In many ways I feel I have been in graduate school for scarcely any time at all; in others it's hard to remember what it was like *not* to be a Ph.D student.

Many people have contributed to my development as a linguist and, directly or indirectly, to this dissertation. I feel certain I will fail to mention some of them, but will do my best to be comprehensive.

To begin, I would like to thank the members of my committee. The first of these thanks belongs to my advisor Sabine Iatridou, whose guidance throughout my five years at MIT has been invaluable, and who has contributed enormously to who I have become as a linguist and a researcher. She has been a source of not only academic and professional guidance, but of emotional support as well. Her confidence in me has encouraged me to accomplish more than I might have done otherwise.

David Pesetsky has also been a source of advice and guidance not only while I have been writing this dissertation, but throughout my graduate career. I deeply appreciate the ways in which he has helped me to clarify my thoughts about particular projects and phenomena, and to be more precise when developing those thoughts into technical implementations, without ever insisting on any particular theoretical approach.

Though the last to join my committee, Norvin Richards played a central role in the development of the ideas ultimately expressed in this dissertation. He has been generous with his time and his advice, and I have appreciated very much his willingness to talk at length about the relation between topics discussed here and his own work; though none of that discussion ultimately made it into what I have written here, it has continued to profoundly influence the way I think about clausal structure.

I have benefitted enormously from the advice and knowledge of many other members of the linguistics faculty at MIT, permanent and visiting, besides those who served directly on my dissertation committee. I would like to particularly express my thanks and appreciation to Adam Albright, Elena Anagnostopoulou, Michel DeGraff, Kai von Stechow, Edward Flemming, Michael Kenstowicz, Shigeru Miyagawa, Donca Steriade, and Hedde Zeijlstra.

As wonderful as the faculty here has been, there is much more to the linguistics program at MIT than its faculty. I have been extremely lucky to find myself part of a community of graduate students filled with clever and intellectually curious people. Let me first acknowledge my fellow members of ling-06: Alya Asarina, Luka Crnic, Patrick Grosz, Omer Preminger, Kirill Shklovsky, and Tue Trinh. If I had not found myself surrounded by engaged, intelligent, and assertive people in my first year, I cannot imagine having found the experience as congenial as I did. I would also like to particularly mention Claire Halpert, Hrayr Khanjian, Patrick Jones, and Jen Michaels, all of whom have enormously improved my time in Cambridge and at MIT in all kinds of ways.

As much as I have enjoyed my time at MIT, it was during my undergraduate degree at McGill that I was first introduced to generative linguistics. Both Glyne Piggott and Lisa Travis provided invaluable mentorship to me as an undergraduate student, and both shaped the ways I think about language and linguistic theory, influencing the linguist I would turn out to be. Looking back yet further, I have been continually aware while writing this dissertation that I can trace some of its roots to two teachers I met earlier in my education. Allyson deJong taught the French class in which I first consciously noticed the compositional interaction of aspect and tense (an interaction that remains central to many of my research

projects), and Margaret Willis not only instilled in me an appreciation for rhetoric and composition that I hope never to lose, but was also one of the few teachers to teach the fundamentals of English grammar, which was part of my motivation to take introductory linguistics in my first year at McGill.

Finally, I would like to thank the many members of my family on whose support I have relied in the last five years. Foremost among them is my husband Mark, who has borne the brunt of my impatience and frustration at various points over the years, as I have dealt, rarely graciously, with the stresses that are part of any graduate program. For his love and patience I am extremely grateful. Though geographically distant, the rest of my family has also been a source of emotional support throughout my academic career. I would especially like to express my appreciation for my mother, whose unwavering faith in my abilities has carried me through those times when I doubted, however briefly, that I could accomplish what I had set out to do. I am so pleased to have lived up to her faith in me.

Contents

1	Overview	17
2	The Morphosyntax of Auxiliary BE	21
2.1	Two patterns of auxiliary use	21
2.1.1	Additive auxiliary patterns	23
2.1.2	Overflow auxiliary patterns	25
2.2	Accounting for the overflow pattern: “default” auxiliaries	28
2.2.1	Inadequacy of additive accounts	29
2.2.2	Morphology-driven selection: further issues	33
2.2.3	Towards an account of the overflow pattern: stranded inflection	35
2.3	Verbal inflection, stranded features, and auxiliary BE	38
2.3.1	Verbal inflection and Agree	40
2.3.2	Unspecified heads, visibility, and “markedness”	50
2.3.3	Interim summary	54
2.3.4	Illustration: English and Arabic	55
2.3.4.1	English	56
2.3.4.2	Arabic	63
2.3.5	Head movement	69
2.3.5.1	Illustration: Latin	71
2.3.6	The morphological realization of stranded features as auxiliaries	77
2.3.7	Summary	82
2.4	Further Illustration	86
2.4.1	Kinande	87
2.4.2	Basque	89

2.4.3	Finnish	93
2.4.4	Developments from Latin: French and Romanian	95
2.4.4.1	French	96
2.4.4.2	Romanian	100
2.5	Implications of downward feature valuation	103
2.5.1	Against Lowering and Raising	104
2.5.2	Implications of reverse Agree	109
2.6	Previous default approaches to auxiliaries	114
2.7	Conclusion	121
3	Auxiliary HAVE: auxiliary selection and related issues	125
3.1	Introduction	125
3.2	HAVE as BE +	127
3.3	Structure of the perfect	133
3.3.1	A dedicated projection for the perfect	134
3.3.2	Locating prepositional content in the perfect	137
3.3.3	There is no independent P^0 in perfects	139
3.3.4	Prepositional features on Perf^0	141
3.4	Prepositional HAVE and auxiliary selection	144
3.4.1	Uniform HAVE and uniform BE languages	145
3.4.2	Alternations based on argument structure	147
3.4.3	Interlude: reverse Agree	154
3.4.4	Person/Number Driven Alternations	156
3.4.5	Interim summary	159
3.4.6	Remaining challenges: clitics, tense, and modality	162
3.5	Other accounts of auxiliary selection	165
3.5.1	Incorporation and auxiliary HAVE	165
3.5.2	HAVE and Case	171
3.5.3	Semantic approaches to auxiliary selection	175
3.6	Conclusion	178
4	DO-support	179
4.1	Introduction	179

4.2	English <i>do</i> -support as a “rescue” operation	180
4.3	DO cross-linguistically	183
4.3.1	Danish, Norwegian, and Swedish	184
4.3.2	Monnese	188
4.3.3	Breton	191
4.3.4	Summary: a (partial) cross-linguistic profile of <i>Do</i> -support	193
4.4	Towards a theory of DO-support	195
4.5	Previous analyses of DO	201
4.6	Conclusion	206
5	Verbal inflection and the left periphery: Counterfactuals	207
5.1	Introduction	207
5.2	Counterfactual inflection	208
5.2.1	C^0 , T^0 , and counterfactual inflection	215
5.3	Conditional Inversion	217
5.3.1	Conditional inversion and counterfactuals	218
5.3.2	A syntactic account of conditional inversion in counterfactuals	221
5.3.3	Limited conditional inversion in English	226
5.3.4	Conditional inversion: summary	230
5.4	Auxiliaries used to support “fake” tense and aspect	230
5.5	Conclusion	234
6	Conclusion	237

List of Abbreviations

ABS	absolutive
ACC	accusative
ADE	adessive
AOR	aurist
CL	class marker (Bantu agreement)
COND	conditional
CONT	continuative
DAT	dative
DEF	definite
DET	determiner
ERG	ergative
F	feminine
FUT	future
GEN	genitive
HAB	habitual
IMP	imperative
IMPF	imperfective
INCP	inceptive
INF	infinitive
M	masculine
MOD	modal
NEG	negative marker
NOM	nominative
PTCP	participle
PASS	passive
PAST	past
PERF	perfect
PFV	perfective
PL	plural
PRES	present
PROG	progressive
SG	singular

Chapter 1

Overview

This dissertation is concerned with the broad question of why auxiliary verbs occur in natural language. The first (and longest) chapter is focused on auxiliary BE; subsequent chapters turn to similarly default auxiliaries HAVE and DO.

From one perspective, the answer pursued here is an uncontroversial one. I argue that the morphosyntax of some languages is such that they require an additional verb in some contexts, and that in the absence of further requirements languages choose a default or contentless verb for this role. The view that BE, particularly copular BE, expresses tense in sentences whose predicate (a noun or adjective) cannot be temporally inflected goes back to Aristotle.¹

From another perspective, however, the analysis of auxiliaries advanced in this dissertation is more radical. Generative linguistics has almost universally assumed that auxiliary verbs interact with the inflectional system much as main verbs do, as syntactic heads that may combine with or be assigned inflectional and agreement morphology. Such approaches are schematically represented in (1), where X^0 stands in for functional inflectional categories such as Asp(ect)^0 , Voice^0 , etc. Auxiliary BE may occur either as the head of X^0 itself, or as the head that *selects* X^0 :²

¹*De Interpretatione* 16b6-19, discussed in Ackrill (1963) and Moro (1997).

²This head is identified here as a dedicated auxiliary category Aux^0 ; it has also been commonly identified as V^0 .

(1)

a.

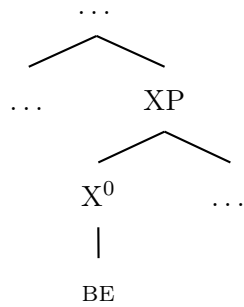

b.

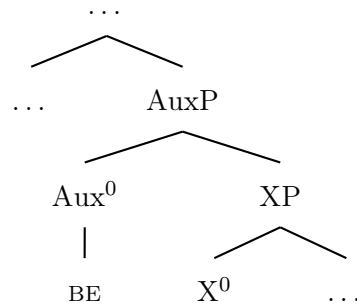

I will refer to this as the *selectional approach* to auxiliary distribution: by assuming that auxiliary BE is projected in the syntax, this view implicitly requires that auxiliaries are *selected for* by other syntactic elements.

In contrast to this standard view, I argue in this dissertation that auxiliary verbs (particularly auxiliary BE) are fundamentally unlike main verbs in that they reflect *failures* of the inflectional system: BE is not directly selected for, but is instead inserted to support inflectional material that was unable to combine with a main verb.

Chapter 2 focuses on what the prototypical default auxiliary verb BE. This chapter demonstrates that such an approach to auxiliary BE is not only conceptually appealing – allowing uniform representations of clause structure across languages with different auxiliary patterns – but it is also empirically necessary. Section 2.1 describes a particular pattern of auxiliary use, which I call the *overflow pattern*, that can only be adequately described by a “rescue strategy” account of auxiliary BE. The majority of the chapter is dedicated for formalizing an approach to verbal inflection that can account for the overflow pattern of auxiliary use. I frame the analysis in terms of Agree, proposing that in some configurations inflectional features can fail to Agree with the main verb. In such contexts, the morphological component inserts BE to allow the verb to be realized. Crucially, however, I argue that Chomsky’s (1998) definition of Agree must be modified, in order to allow features that are both valued and interpretable on inflectional heads to value uninterpretable counterparts lower down in the clause. The general analysis of verbal inflection and auxiliary use is able to attribute variation in auxiliary distribution across languages to two factors independently known to differ cross-linguistically: which features are syntactically specified, and thus visible to Agree (relating to traditional notions of “markedness”), and the presence or absence of head movement between particular positions in the inflectional domain.

Subsequent chapters extend this general approach to auxiliaries and verbal inflection into a variety of related domains, including the use of HAVE and DO as auxiliaries (with a focus on *Do*-support and auxiliary selection), the behaviour of auxiliaries in reduced relative clauses and under VP Ellipsis, and the interaction of verbal inflection and auxiliaries with counterfactuality.

Chapter 3 addresses auxiliary HAVE and its use as a perfect auxiliary. The focus of the chapter is auxiliary selection, the alternation between HAVE and BE as perfect auxiliaries both within and across languages. Following Freeze (1992) and Kayne (1993), I argue in favour of the view that auxiliary HAVE results from the presence of an additional prepositional element in the position that would otherwise have auxiliary BE inserted. In contrast to these earlier accounts, which proposed that HAVE results from incorporation of a prepositional element to BE, I argue that this additional element *originates* in the position of the auxiliary. Auxiliary selection thus arises from the variable ability of that position to *divest* itself of prepositional features. In the course of developing this analysis, I argue that the general approach to verbal inflection and auxiliaries outlined in chapter 2 has both empirical and conceptual advantages over other accounts that have been proposed. In particular, the “reverse” directionality of Agree plays a key role in several areas.

Chapter 4 investigates the use of DO as a “support” auxiliary not only in English but in the mainland Scandinavian languages, the Northern Italian dialect Monnese, and Breton. The motivation for this investigation is the potential conflict between the analysis of BE advanced in chapter 2 and traditional analyses of DO-support: both involve the “last resort” insertion of a default verb in order to morphologically realize stranded inflectional information. I demonstrate that the typological profile of DO-support is incompatible with its traditional analysis, and sketch an alternative analysis in which DO is not inserted as a rescue verb of some kind, but instead realizes an instance of v^0 that is linearized non-adjacent to the lexical verb.

Chapter 5, finally, extends the framework of chapter 2 to the domain of counterfactual inflectional. Counterfactual clauses in many languages are marked by “repurposed” inflectional morphology: in particular, many languages mark counterfactuals with past inflection, in the absence of any past tense interpretation (Steele, 1975; James, 1982; Iatridou, 2000, a.o.). Arguing that this repurposed past inflection is associated with positions in the left periphery, rather than with T^0 , I demonstrate that two little-discussed constructions closely

associated with counterfactuality – conditional inversion and counterfactual auxiliaries – fall out as part of a typology predicted by the system of verbal inflection developed in chapter 2.

Chapter 2

The Morphosyntax of Auxiliary BE

2.1 Two patterns of auxiliary use

As mentioned in the introduction, the approach to auxiliaries pursued in this dissertation is empirically motivated by a pattern of auxiliary use I will refer to as the *overflow pattern*. In the overflow pattern, auxiliaries appear only in certain *combinations* of inflectional categories. The Latin perfect passive provides an example of this pattern: no auxiliary occurs in the simple perfect (1a) or the simple passive (1b), but one is required when the categories co-occur in the perfect passive (1c):

- (1) a. amavi
love.1SG.PERF
'I loved, I have loved.'
- b. amor
love.1SG.PASS
'I am loved.'
- c. amatus **sum**
love.PERF.PASS be.1SG.PRES
'I was loved, I have been loved.'

This contrasts with what I will call the *additive pattern*, in which categories that occur with an auxiliary *always* occur with an auxiliary. English auxiliaries are an example of this second pattern of auxiliary use: the progressive (*was reading*) and the passive (*was read*) both require an auxiliary verb independently, and two auxiliaries are used in the perfect passive (*was being read*).

We can schematically represent the two patterns as in (2) and (3), where F and G represent potential inflectional categories such as *past*, *progressive*, *passive*, etc.:

(2) *Additive Pattern:*

$$\begin{aligned} F &\rightarrow BE \\ G &\rightarrow BE \\ F + G &\rightarrow BE + BE \end{aligned}$$

(3) *Overflow Pattern:*

$$\begin{aligned} F &\nrightarrow BE \\ G &\nrightarrow BE \\ F + G &\rightarrow BE \end{aligned}$$

The next two sections exemplify these two patterns with data from a range of languages. Once the patterns themselves have been described, section 2.2 turns to the issues raised by the overflow pattern for common assumptions about the syntax of auxiliaries. I will argue that the overflow pattern argues very strongly in favour of an account in which auxiliaries represent a *repair* strategy for structures in which inflectional features have failed to combine with the main verb.

The data presented here involve auxiliary BE used to express contrasts in the “middle” functional structure of the clause, the domain in which primarily temporal information is represented, above the “expanded *vP*” domain in which argument structural information is widely assumed to be encoded and manipulated (Pylkkänen, 2008, a.o.). Most of the auxiliary patterns we will see in this chapter will be firmly situated in this temporal domain, involving the interaction of tense with various aspectual values; some, however, will interact with “lower” categories such as voice (passive vs. active), and others with potentially “high” categories such as modality.

Before we proceed, note that the labels *additive* and *overflow* apply to particular auxiliary patterns, rather than to any language as a whole. In the course of this chapter we will encounter some languages that have additive patterns with respect to some categories, but overflow patterns with respect to others.

2.1.1 Additive auxiliary patterns

This section begins by briefly reviewing the additive pattern, familiar from widely-studied languages of modern Europe. It is illustrated in this section with data from English, Basque, and Finnish.

As mentioned above, in the additive pattern certain inflectional categories always occur with an auxiliary, regardless of the other categories represented in the clause (finiteness, aspectual value, etc.).¹When multiple auxiliary-taking categories co-occur, multiple auxiliaries appear in a single clause.

In English, for example, the progressive and passive both display an additive pattern with auxiliary *be*. As we see in (4) and (5), both these categories require an auxiliary regardless of their wider syntactic context: an auxiliary form of *be* occurs in both finite and non-finite contexts, as well as below the perfect non-*be* auxiliary *have*:²

(4) *English progressive uniformly requires be:*

- a. *Finite:* The children **were** eating the cake.
- b. *Non-finite:* The children want to **be** eating the cake.
- c. *Perfect:* The children have **been** eating the cake.

(5) *English passive uniformly requires be:*

- a. *Finite:* The cake **was** eaten.
- b. *Non-finite:* The cake seemed to **be** eaten.
- c. *Perfect:* The cake has **been** eaten.

Finally, when these two categories co-occur in the progressive passive, we see two auxiliaries:

(6) *English progressive passive occurs with two be's:*

¹This description of the additive pattern is a slight simplification, applying primarily to full clauses, particularly finite clauses. In English, for example, auxiliary *be* does *not* always occur in absolute or reduced relative clauses, despite the fact that the passive and the progressive both demonstrate additive patterns of auxiliary use in main clauses.

²The perfect auxiliary *have* also conforms to an additive pattern in English. The use of HAVE as an auxiliary will be taken up in chapter 3, where a parallel analysis to the one proposed here for BE will be advanced. The analysis of HAVE auxiliaries will draw on the extensive literature, beginning with Freeze (1992) and Kayne (1993), proposing that both main-verb and auxiliary forms of HAVE verbs are syntactically derived from the structure of a verb BE. This view of HAVE, particularly auxiliary HAVE, is particularly compatible with the approach to auxiliaries that will be developed here, where they are *post-syntactic* realizations of abstract functional structure.

- a. *Finite*: The cake **was being** eaten.
- b. *Non-finite*: The cake seemed to **be being** eaten.
- c. *Perfect*: The cake had **been being** eaten.

Similar cases can be found throughout the Germanic and Romance language families, several of which will be discussed further in section 2.4.

We find additive patterns widely attested beyond the Indo-European family as well, however. Consider, for example, the auxiliary pattern found in Basque. In Basque, both perfective and imperfective aspect are marked by suffixes on the main verb, while tense is marked on an auxiliary (Laka, 1993; Arregi, 2000). The present perfective and past imperfective are illustrated in (7) (examples drawn from Arregi (2000)).³

- (7) a. *Basque present perfective*:
- Jon-ek liburu irakurr-i **da**.
 Jon-ERG book read-PFV AUX.PRES
 “Jon has read the book.”
- b. *Basque past imperfective*
- Jon asarra-tzen **sa-n**.
 Jon get.angry-IMPF AUX-PAST
 “Jon used to get angry.”

We find another additive pattern in the Finnish perfect, which is formed with a present or past tense form of the verb *olla* ‘to be’ followed by a participial form of the main verb. This is illustrated for present and past perfects in (8a-b).

- (8) a. Lapset **ovat** syö-neet kakku.
 The.children be.PRES eat-PTCP the.cake
Present Perfect
- “The children have eaten the cake.”
- b. Lapset **olivat** syö-neet kakku. *Past Perfect*
 The.children be.PAST eat-PTCP the.cake

³Basque auxiliaries alternate between intransitive ‘BE’ (*izan*) and transitive ‘HAVE’ forms (**edun/*ezan*) forms. Following Arregi (2004), I assume that this differs from classical cases of auxiliary selection in being determined by the agreement morphology marked on the verb, rather than by strict considerations of structural transitivity; as Arregi shows, *any* second agreement marking on the verb triggers the use of the ‘HAVE’ auxiliary, while in Romance and Germanic it is the presence of local internal and external arguments only that is involved in the calculation of transitive auxiliary alternations.

It should also be noted that a small set of verbs in Basque do allow synthetic past and present forms (Arregi, 2000; de Rijk, 2007). This fact will be taken up in section 2.4.2.

“The children had eaten the cake.”

In all three languages discussed here, certain inflectional categories reliably co-occur with an auxiliary. This is the hallmark of the additive auxiliary pattern.

2.1.2 Overflow auxiliary patterns

The overflow pattern exhibits a very different surface profile from the additive pattern. In the cases we will see below, *individual* categories have simple, non-periphrastic forms, but certain *combinations* of inflectional categories trigger the occurrence of an auxiliary BE.

Concrete examples illustrating the overflow pattern are given below from Kinande, Latin, and Arabic.

Kinande is a Bantu language, and it exhibits an overflow interaction between tense and aspect which is typical for the language family: simple forms exist that express either tense or aspect alone, but clauses that express both require a tense-marked auxiliary followed by an aspectually-marked main verb.

Kinande marks four “distances” of past tense, as we see illustrated in (9).⁴ These past tense forms have default perfective interpretations.

- (9) a. tu-kábi-húma
1PL-PAST1⁵-hit
“We hit (just now).”
- b. tú-lya-humá
1PL-PAST2-hit
“We hit (earlier today).”
- c. tw-á-húma
1PL-PAST3-hit + "tone patten A"
“We hit (recently).”
- d. tw-a-huma
1PL-PAST3-hit + "tone pattern B"
“We hit (long ago).”

⁴The Kinande data in this chapter are due to Patrick Jones (p.c.), with some additions from my own elicitation in the Spring of 2008.

⁵The glosses provided for past tense forms here are much simplified. Many of the inflectional prefixes of the Kinande verbal system do not straightforwardly map onto specific temporal interpretations; instead there is often a one-to-many mapping of morphemes and contexts of occurrence. In addition to this, certain inflectional patterns are distinguished not by segmental morphemes, but instead by their tonal patterns. The tonal patterns of Kinande verbs have traditionally been analyzed as highly complex, for example by Hyman and Valinande (1985). Jones (2011) argues convincingly, however, that our view of the system can be vastly

The present tense is unmarked, as is common throughout Bantu languages (Nurse, 2008). In the unmarked present, a variety of aspectual distinctions can be marked on simple verb forms. (10) illustrates the imperfective, the progressive, the inceptive, and the continuative:

- (10) a. tu-ká-húma
 1PL-IMPF-hit
 “We hit (habitually or progressively).”
- b. tu-nému-húma
 1PL-PROG-hit
 “We are hitting.”
- c. tu-limu-húma
 1PL-INCP-hit
 “We are starting to hit.”
- d. tu-kiná-humá
 1PL-CONT-hit
 “We are still hitting.”

Simple forms are not, however, able to express *both* tense and aspect. A past tense aspectual form requires a tensed auxiliary followed by an aspectually-inflected main verb, as shown by (11a) for the recent past progressive, and (11b) for the remote past imperfective:

- (11) a. tw-á-bya i-tu-nému-húma
 1PL-PAST3-be +toneA LNK-1PL-PROG-hit
Recent Past + Progressive
 ‘We were (recently, not today) hitting.’
- b. tw-a-bya i-tu-ká-húma
 1PL-PAST3-be +toneB LNK-1PL-IMPF-hit
 “We hit (habitually or progressively, long ago).”

In this overflow pattern, inflection that is for some reason unable to be expressed on the main verb might be said to “spill over” onto a default auxiliary form.

simplified by dividing the class of inflectional prefixes into two categories: those behave morphophonologically like full verb stems, and thus disrupt tonal assignment to the “main” verb stem, and those that do not. These complexities will be largely set aside here, though some details will be revisited in section 2.4.1 in the full analysis of the Kinande pattern.

The glosses in this example also abstract away from a morphophonological contrast in the verb stem: the final vowel of the stem in all all these forms is an *inflectional final suffix* or *final vowel* morpheme, which can be separated from the verb root by a series of derivational suffixes. There is, moreover, some possibility that the form glossed here as the “immediate past” is in fact a perfect of recent events. The remaining three tense forms, however, are not subject to this possibility.

We find a formally similar interaction between the perfect and the passive in Latin. Simple verb forms exist for both the perfect and the passive in isolation, as illustrated in (12a-b).

The passive perfect, by contrast, requires an auxiliary followed by a perfect passive participle, as shown in (12c).⁶

- (12) a. Puellae crustulum **consumpserunt**.⁷ *Perfect*
 girl-PL.NOM small.pastry-ACC eat-PL.PFV
 “The girls ate the little pastry.”
- b. Crustulum **consumitur**. *Passive*
 small.pastry-NOM eat-PRES.PASS
 “The little pastry is (being) eaten.”
- c. Crustulum **consumptum est**. *Perfect + Passive*
 small.pastry-NOM eat-PASS.PTCP **be**.3SG.PRES
 “The little pastry was / has been eaten.”

The use of the auxiliary in (12c) is strongly reminiscent of the Kinande cases in (11). Once again we find that the main verb seems to be able to morphologically express a certain number of inflectional categories (one in Kinande, two in Latin), but that an auxiliary is required to express any inflectional categories beyond that number.

A third clear example of an overflow pattern can be found in Arabic, genetically unrelated to either Kinande or Latin. The examples here are drawn from Standard Arabic, but the same pattern is instantiated across many contemporary varieties. As in Kinande, we find an overflow interaction between tense and aspect.

Both imperfective and past tense can be expressed on simple verbs, as shown in (13a-b), with present tense and perfective interpretations, respectively.

To express a past imperfective, however, it is necessary to use a past tense auxiliary followed by an aspectually-inflected main verb, as shown in (13c):

- (13) a. darasa
 study.PAST.PFV.3SGM
 “He studied.” (Benmamoun, 2000, 27, 23a)

⁶This is true not only of the perfect of passives, but also of the perfect form of deponent verbs, i.e. verbs that are syntactically active but morphologically passive (Embick, 2000). The issue of deponents will be taken up in the analysis of Latin in section 2.3.5.1.

⁷Thank you to Jennifer Faulkner and Elena Innes for help producing these Latin examples.

- b. ya-drusu
3M-IMPF.study
“He studies.” (Benmamoun, 2000, 28, 24a)
- c. kaana ya-drusu
be.PAST.3SGM 3M-IMPF.study
“He was studying / He used to study.” (Benmamoun, 2000, 29, 26a)

This is precisely parallel to the pattern observed in Kinande, with the exception that Kinande has a wider range of aspectual and past tense forms that interact in the same way. Once again it appears that the verb is able to “support” only one instance of verbal (non- φ) inflection, with any additional categories requiring the addition of an auxiliary BE.

2.2 Accounting for the overflow pattern: “default” auxiliaries

The representations provided to auxiliary BE in the literature – whether adopted implicitly or explicitly – accommodate additive patterns of auxiliary use fairly naturally. What we will see in this section, however, is that they do *not* naturally accommodate the overflow pattern. Instead the overflow pattern argues strongly in favour of a model of auxiliaries in which they occur in response to the *syntactic* failure of inflection to combine with the main verb.

This section is structured as follows. Section 2.2.1 reviews the selectional approaches to auxiliary distribution first introduced in the introduction. These approaches have been advanced in the context of additive patterns of auxiliary use, and I demonstrate that, so long as they are framed in exclusively syntactic terms, they encounter grave difficulties once we attempt to extend them to overflow patterns of auxiliary use.

Section 2.2.2 turns to what we might describe as *hybrid* accounts: versions of the selectional approaches that propose that syntactic selection is driven by morphological properties of participial main verbs. I argue that, regardless of the morphological framework adopted, all such accounts require the same *descriptive* generalization of the contexts in which auxiliary verbs occur: that the occurrence of auxiliary BE is triggered in response to restrictions on the “amount” of inflection that can be expressed on the main verb.

This leads to the conclusion of section 2.2.3, which is that the conditions governing the distribution of auxiliary verbs are indeed best expressed in syntactic terms, but not in terms of syntactic *selection*. I argue that auxiliary verbs are the byproduct of conditions

of syntactic *locality* on the expression of verbal inflection on the main verb. This basic motivation is developed into a broader theory of verbal inflection in section 2.3.

2.2.1 Inadequacy of additive accounts

As mentioned above, the position adopted in much of the syntactic literature, often implicitly, is that auxiliary BE corresponds straightforwardly to a syntactic head, in one of the ways schematically represented in (14), repeated from (1) in chapter 1.

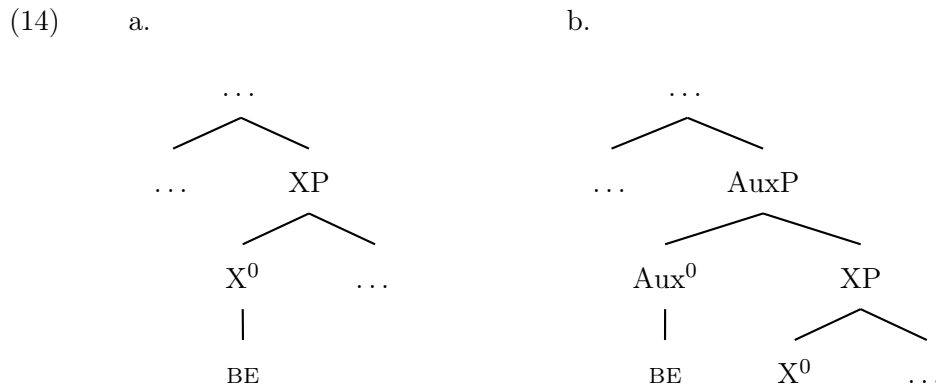

Additive patterns of auxiliary use, which have been the focus of syntactic work on auxiliary verbs, can be naturally accounted for by such accounts. I demonstrate in this section, however, that *overflow* patterns of auxiliary use are fundamentally incompatible with either of the schemas in (14). Any successful account of the overflow pattern, I argue below, must instead analyze auxiliaries as being inserted to support inflectional material that was unable to be realized on the main verb: that is, in response to something akin to the Stray Affix Filter (Lasnik, 1981).⁸

The earliest syntactic approaches to auxiliary verbs predate the association of inflectional categories such as aspect or voice with dedicated functional projections. Auxiliaries such as BE were thus assumed to head either general category AUX or one of a series of nested VPs. footnoteThese proposals also tend to pre-date the widespread integration syntax with compositional approaches to semantics. The meaning of the progressive or the perfect,

⁸Since at least Chomsky (1957), it has been widely assumed that DO – not BE – is a verb inserted in response to something like the Stray Affix Filter. Adopting the logic of the Stray Affix Filter for auxiliary BE might therefore appear to be in conflict with the existence of DO-support. I return to the topic of DO-support in chapter 4, where I demonstrate that a more careful examination of DO-support, especially in languages other than English, demonstrates that DO-support is *not*, in fact, triggered by the inability of inflectional material to find a host on the main verb. As a result, the conflict between my analysis of BE and the facts of DO-support is only apparent.

for example, would be “expressed” by an auxiliary verb in combination with a present or past participle: for the most part, the question of how this structure might give rise to a particular interpretation did not arise. The earliest example of this approach in modern generative syntax can be found in the classic analysis of the English auxiliary system from Chomsky’s (1957) *Syntactic Structures*, which proposed a single AUX constituent which could be rewritten as a sequence of modal and auxiliary verbs, introduced together with the affixes they required of their complements, a position taken up in work such as Steele (1978) and Akmajian et al. (1979). An alternative position, proposed by Ross (1967, 1969), was that auxiliary verbs headed a sequence of nested VPs, not being categorically distinct from main verbs.⁹ The nested-VP view of auxiliary-containing clauses can also be found in Huddleston (1974), Emonds (1978), Pollock (1989), and Roberts (1998), among many others.¹⁰

An increasing body of work in syntax and semantics, however, has argued for the view that inflectional categories (aspect, modality, voice, etc.) are associated with a sequence of dedicated functional projections. This view was introduced with regard to aspect by Tenny (1987). A highly articulated view of clausal structure is similarly developed in the work of Cinque (1999). This basic view of clausal architecture is now firmly established in work on the semantics of inflectional categories, and in much related work on their syntax.¹¹

The association of inflectional categories with functional heads has implications for the syntactic representation of auxiliary verbs. As illustrated in (15), repeated from (1) in the introduction, an auxiliary BE can itself be the head of an auxiliary-taking category, as in (15a); or BE can head a projection separate from the auxiliary-taking category, as in (15b):

⁹Ross’s actual position was that auxiliary verbs take full clausal complements, which are collapsed into a single clause in the course of a derivation. This view of auxiliary structures as multi-clausal can still be found in some contemporary work. Baker (2008), for example, proposes essentially this view of auxiliary verb constructions in Bantu languages.

¹⁰Representing an early attempt to integrate this general syntactic approach with a compositional semantic theory, Partee (1977) argues that English *be* is ambiguous between its ordinary copular use (also responsible for passive *be*) and a progressive *be* that gives rise to progressive aspectual interpretations and imposes selectional requirements on its subject.

¹¹It is not possible to give a complete survey of the work that has established this framework. Influential work establishing the success of this approach, however, includes Tenny (1987, 1994); Smith (1991); Klein (1994); Giorgi and Pianesi (1997); Kusumoto (1999); Demirdache and Uribe-Etxebarria (2000); among many others.

(15)

a.

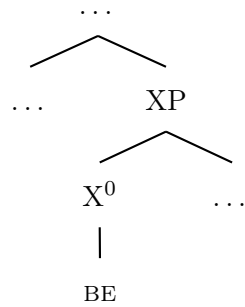

b.

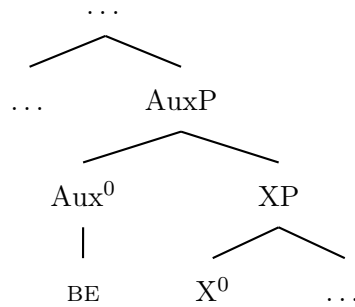

A structure such as (15a) is adopted by both Tenny (1987) and Cinque (1999). Tenny argued for the syntactic representation of a category Asp^0 , headed in English by the aspectual auxiliaries *have* and *be*, directly in line with the view in (15a). The same general approach can be found in Cinque (1999), where it fits nicely together with the view that more ‘contentful’ auxiliary verbs (particularly motion-verb-derived auxiliaries) also head functional aspectual projections. Jaeggli and Hyams (1993) also explicitly argue for this view of clausal structure.

Structures such as (15b), in which BE heads an independent projection that selects (or is selected by) an inflectional projection, are widely adopted in work that assumes either a vacuous or a general copular semantics for BE itself, as in Rothstein (1999, 2004). A structure roughly along the lines of (15b) is also assumed in Kayne’s (1993) analysis of auxiliary selection, which proposes the presence of a dedicated BeP in the syntax of perfect constructions, and can be inferred in Chomsky (1993), who proposes that auxiliary verbs BE and HAVE delete by LF as they are semantically vacuous. This is also the view advanced by Dechaine (1993, 1995), who interleaves auxiliaries heading VPs with functional projections such as AspP, TP, etc. An approach such as (15b), where auxiliary BE co-occurs with but is non-identical to an inflectional functional category, is also implicit in much work on the semantic interpretation of aspectual participles, including Iatridou et al. (2003), Pancheva (2003), and Embick (2004), among many others. This body of work investigates the semantic interpretation of participles, observing that aspectual or passive interpretations are available to participles in the absence of auxiliary verbs. This is the case, for example, in reduced relative constructions such as (16), which maintain progressive and passive interpretations despite lacking an (overt) auxiliary (Iatridou et al., 2003):

- (16) a. The children **eating** the cake are noisy.
 b. The cake **eaten** by the children was made of ice-cream.

The existence of such constructions raises questions for a syntactic approach such as (15a), where the auxiliary is *identified* with the functional head that contributes a particular inflectional interpretation.

What *unifies* these approaches to auxiliary verbs is the assumption that auxiliary verbs are *selected for* in certain inflectional contexts. As stated at the beginning of this section, this view of auxiliary verbs provides a natural account of the additive pattern – an unsurprising result, given the almost exclusive focus on languages exhibiting the additive pattern in work on auxiliary verb constructions. In the additive pattern, recall, certain inflectional categories always co-occur with an auxiliary. This relationship can easily be expressed in selectional terms: the additive pattern is one in which certain inflectional categories *select* an auxiliary verb.

The overflow pattern of auxiliary selection, by contrast, resists explanation in purely selectional terms. Recall that in section 2.1.2, we saw that Kinande, Latin, and Arabic all use auxiliary BE only in the *combination* of inflectional categories: in both Kinande and Arabic BE appears when past tense and certain aspects co-occur, while in Latin BE appears when the perfect and passive co-occur.

In these languages, there is no *single* functional projection that selects an auxiliary: instead BE would be selected by the *combination* of (particular values of) T^0 and Asp^0 , or Asp^0 and $Voice^0$. We could express this schematically as in (17):

- (17) * [AuxP [XP]]
 * [AuxP [YP]]
 ✓ [AuxP [XP [YP]]]

The selectional relationship expressed by (17), however, is non-local. Categorical selection is widely assumed to be a strictly *local* relationship (as expressed by the Projection Principle of Chomsky, 1986b). The overflow pattern of auxiliary use thus appears to be fundamentally incompatible with a purely selectional approach to auxiliary BE.¹²

¹²Even if selection is strictly local, it would in principle be possible to re-create a relationship analogous to (17) via *indirect* selection. Consider the overflow pattern in Latin, in which an auxiliary occurs only when the perfect and the passive co-occur. It could be that though neither Asp^0 nor $Voice^0$ select Aux^0

As alluded to in section 2.1.2, the overflow pattern suggests an alternative to a purely selectional account: that auxiliary BE occurs to realize inflectional information that for some reason cannot be realized on the main verb.

Indeed, it has often been suggested even in the context of the additive pattern that the syntactic selection of auxiliaries is not an arbitrary syntactic fact, but instead reflects *morphological* properties of the participial main verb. I argue in section 2.2.2 that any such morphological justification for auxiliary verbs leads not to the view that auxiliaries are syntactically *selected*, but they occur as a *repair* to structures in which inflection is not realizable on the main verb.

2.2.2 Morphology-driven selection: further issues

I have just argued that an account of auxiliary distribution in terms of blunt syntactic selection cannot be extended to the overflow pattern in any kind of principled way. A common view in traditional grammars, however, is that auxiliary verbs occur in response to the *deverbal* nature of participial main verbs. This traditional view has sometimes been carried over into selectional accounts, offered as an *explanation* or *justification* of the fact that auxiliary BE is syntactically selected by certain functional heads.

In this section I demonstrate that this move is insufficient to save the selectional approach to auxiliary verbs, independently of the specific approach to the morphosyntactic interface one adopts. Two main approaches to the morphosyntactic interface can be found in the literature. The first assumes that morphology provides the *input* to the syntactic derivation, i.e. that syntax manipulates already-inflected words. This is known as the *lexicist* approach (Chomsky, 1993, a.o.). The second proposes that morphology interprets the *output* of a syntactic component that manipulates abstract lexical and functional elements. Such approaches are collectively known as *post-syntactic* or *interpretive* morphological models, and include Distributed Morphology (Halle and Marantz, 1993, 1994; Harley and Noyer, 1999; Noyer, 1997) and Nanosyntax (Starke, 2010).

To influence the syntactic selection of auxiliaries, the deverbal status of participles must be visible to the syntactic computation. The two morphosyntactic approaches just men-

independently, Voice^0 occurs not with standard-variety Asp^0 but with Asp'^0 , and that Asp'^0 *does* select Aux^0 .

Note, however, that the required selectional relationship between Voice^0 and Asp^0 (and between other pairs of heads in other languages) holds not just between the two categories, but between particular *values* of those categories: Voice^0 would *not* require Asp'^0 when the latter expresses imperfective aspect.

tioned result in this information being visible in different ways, but in both cases the hypothesis that auxiliaries occur because of the deverbal status of participles cannot be maintained, and we are led to the conclusion that auxiliaries must occur either to realize the inflectional features of higher functional heads.

Within a lexicalist approach, the participle is already deverbal when it is first merged into the syntactic derivation. This deverbal participle must enter into a relationship with the appropriate functional head (or heads) to “check” its inflectional features, and it is this functional head that is in a selectional relationship with an auxiliary verb.¹³ If the selection of auxiliary verbs is motivated to supply the participle with a categorial verb, however, the lexicalist hypothesis cannot account for the existence of participial auxiliaries.

This can be seen in relation to the concrete English example in (18):

(18) The book was being read.

The hypothesis we are considering is that the occurrence of auxiliaries can be *explained* by the deverbal status of participles. The English passive thus occurs with an auxiliary because the past participle, *read* in (18), is not a verb. In a sentence with multiple auxiliaries, however, the passive auxiliary *also* occurs in a participial form; yet on the lexicalist view we are considering, a participle such as *being* is never a verb, for syntactic purposes. Its occurrence in (18) therefore *cannot* be explained as satisfying the need of the participle *read* to be supplied with a verb. This argument is independent of the fact that, syntactically, participial verbs act like *verbs*, not adjectives or nouns. They are modified by verbal adverbs, and take accusative objects, neither of which is possible for adjectives or nouns.

What the passive auxiliary in (18) does provide is a position in which progressive morphology is expressed; the same can be said of the progressive auxiliary, which provides a position for finite morphology.

Much the same conclusion arises if one adopts a post-syntactic morphological approach. On such an approach, the non-verbal status of participles must result from a deverbalizing head within the syntactic component itself. Unlike the lexicalist account just reviewed, participial auxiliaries do not present an immediate problem for this approach: an auxiliary verb can satisfy a selectional requirement for a verb, and then subsequently combine with

¹³It is not clear that this selection can be *tied* to the deverbal status of the participle: there is no reason why a functional head could not select a main verb, but still itself be selected by an auxiliary verb.

a further deverbalizing head. We could propose, for example, that the progressive and the passive in English both require the presence of an auxiliary because both create deverbal participles from their verbal complements.

Where this account encounters serious difficulty is with the overflow pattern. We are considering the hypothesis that certain structures trigger the occurrence of auxiliary verbs because they involve a functional head that *deverbalizes* its complement (resulting in a participial verb). The viability of this proposal depends on the ability to identify a single functional head that deverbalizes the verb above which it occurs.

In the overflow pattern, however, there is no single head that could be assigned this deverbalizing function: there is no head that, regardless of the context in which it occurs, transforms an ordinary verb into a participle. Instead, it is only the *combination* of certain functional heads that results in a participle being used.

If we adopt an interpretive model of morphology, however, there is a different way to describe the contexts in which auxiliary BE and participles occur: contexts in which the verb combines only with a limited number of inflectional functional heads, with the residue being left to be realized by auxiliaries.¹⁴

2.2.3 Towards an account of the overflow pattern: stranded inflection

In this section I have argued that the widely-assumed position that auxiliary verbs occur simply because certain functional heads select for them, and that variation among languages is the result of arbitrary selectional or morphological differences, cannot be sustained in the face of the overflow pattern. The fundamental reason for this is that selection is, broadly speaking, a matter of the syntactic properties of single functional heads, and the profile of the overflow pattern is that auxiliaries arise due to the combination of *multiple* functional heads in a single clause. I have argued moreover that one of the common *morphological* justifications for auxiliary BE's occurrence – that it provides a verb in the presence of a deverbal participial predicate – encounters difficulties no matter the morphological framework

¹⁴This restriction can also be expressed within a lexicalist model of morphosyntax: that the pre-syntactic morphological component can only “fit” so much inflectional morphology on a main verb, so that additional morphology must be expressed on auxiliary verbs. This account would require a morphological theory that explains why there are limits on the inflectional morphology expressed on main verbs, and why these limits differ in different languages. In section 2.3 I propose a general model of verbal inflection that reduces these questions to independently known parameters of syntactic variation, concerned with the locality of Agree.

adopted.¹⁵

I have alluded several times to another possible “morphological” motive for BE’s occurrence: it occurs not to supply the clause with an otherwise-lacking verb, but to realize inflection that is, for some reason, *not* expressed on the main verb. This perspective is suggested especially strongly by the overflow pattern of auxiliary use, where we see auxiliary BE occurring exactly when we attempt to express more than a certain number of inflectional categories in a single clause.

Why might inflection not be expressed on the main verb? In principle, this could be an arbitrary morphological fact: it could be that the morphological systems of some languages lack the capacity to express certain combinations of inflection on a single verb.

It is a striking fact, however, that in auxiliary constructions, “higher” functional categories (i.e. tense) are expressed on auxiliaries, while “lower” categories (i.e. aspect or voice) are expressed on the main verb. This is *despite* the fact that we could easily imagine a different state of affairs, in which aspectual contrasts were marked on auxiliary BE and tense on the main verb. Though imaginable, such systems do not appear to exist. This suggests that *structural* factors must play a role in shaping the distribution of inflection on auxiliaries and main verb.

If structural factors must play some role, we can ask whether they can provide a complete account of the distribution of auxiliary BE. I argue throughout the remainder of this chapter that they can, once we consider the structural underpinnings of the system of verbal inflection.

Consider the contrast between the additive pattern in English, repeated in (19), and the overflow pattern of Latin, repeated in (20). The inflectional contrasts they exhibit are essentially parallel: a contrast in voice (active vs. passive), and one in aspect.

- (19) a. The children **were** eating the cake.
b. The cake **was** eaten.
c. The cake **was being** eaten.

- (20) a. Puellae crustulum **consumpserunt.** *Perfect*
girl-PL.NOM small.pastry-ACC eat-PL.PFV
“The girls ate the little pastry.”

¹⁵There are other versions of this hypothesis that have been advanced in the literature, notably by Dechaine (1993, 1995), Schütze (2003), Cowper (2010). I argue more directly against these alternatives in section 2.6, towards the end of this chapter.

- b. Crustulum **consumitur.** *Passive*
 small.pastry-NOM eat-PRES.PASS
 “The little pastry is (being) eaten.”
- c. Crustulum **consumptum est.** *Perfect + Passive*
 small.pastry-NOM eat-PASS.PTCP **be.**3SG.PRES
 “The little pastry was / has been eaten.”

The inflectional categories expressed in (19) and (20) would be associated with a sequence of functional projections; following much work in clausal syntax, the functional head associated with passive (which I label Voice^0) is lower than the functional head associated with aspect.

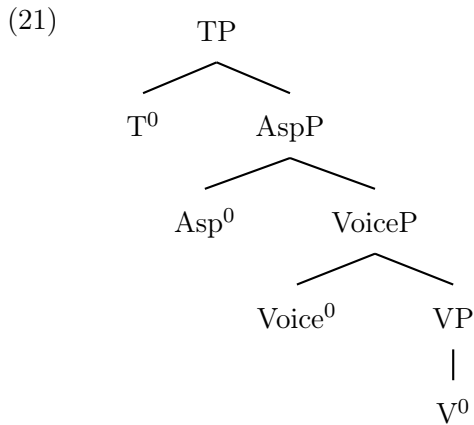

It is clear that the apparently morphological contrast between English and Latin can be expressed instead in structural terms. It is not simply the case that the English verb inflects for one category while the Latin verb inflects for two. Instead the *locality* of functional heads to the verb is crucial: the English verb inflects for a single *most local* functional category (Asp^0 in the progressive, Voice^0 in both the passive and the progressive passive), while the Latin verb inflects for *two* (T^0 and Asp^0 in the perfect, T^0 and Voice^0 in the passive, and Asp^0 and Voice^0 in the perfect passive).¹⁶ The inability of some inflection to combine with a main verb is a *structural* fact: complex inflectional syntax, I argue, can cause inflectional features to be “stranded”, preventing them from ever combining with a structurally distant main verb. Auxiliary BE is then the result of some version of the Stray Affix Filter (Lasnik, 1981), occurring to realize inflection that would otherwise be morphologically “stranded”.¹⁷

¹⁶This assumes that Voice^0 does not interfere in active sentences, for example, a point I return to in section 2.3.2.

¹⁷Indeed, this is essentially what Embick (2000) argues regarding the Latin perfect passive, and what Arregi (2000) proposes regarding Basque additive auxiliaries. Neither of these accounts can be generalized

The question now becomes what syntactic properties result in these different locality conditions on inflection in these two types of languages. In contrast to arbitrary differences of morphology or selection, this predicts that variation in auxiliary patterns will correlate with other independently observable syntactic variation across languages.

Much of the remainder of this chapter is occupied by arguing for a particular implementation of this approach to auxiliary verbs. In the next section I begin by arguing for a syntactic architecture for verbal inflection that can express this approach to auxiliaries.

2.3 Verbal inflection, stranded features, and auxiliary BE

In section 2.2 I argued that the view that auxiliaries arise due to straightforward syntactic selection is incompatible with the existence of the overflow pattern of auxiliary use. I argued that the profile of the overflow pattern suggests instead that auxiliary BE occurs to realize inflection *unable* to be realized on the main verb. In section 2.2.3 I further argued that the “inability” of some inflection to be realized on the main verb must be at least partially *structural*: that the mechanisms manipulating verbal inflection are such that, in some configurations, inflection is unable to combine with the main verb and must be realized instead by the default auxiliary BE.

This section develops a model of verbal inflection that implements the idea that verbal inflection can fail to combine with the main verb. Such a model requires, minimally, the three properties listed in (22):

- (22)
- a. Inflectional information must be associated with a *separate* position from the main verb.
 - b. The mechanism that relates inflectional information to the main verb must be able to *fail*.
 - c. There must be a “repair” mechanism that inserts an auxiliary verb to realize inflection that has failed to combine with the verb.

None of these are controversial, considered independently. (22a) is simply the view, reviewed already in section 2.2.1, that inflectional information is associated with dedicated

beyond those individual languages, however; the details of these accounts are discussed in sections 2.3.5.1 and 2.4.2, respectively.

functional projections such as T^0 and Asp^0 . (22b) is similarly uncontroversial: all mechanisms for creating or licensing inflected heads (head movement, Lowering, Agree, etc.) apply only in certain structural configurations, and are capable of failure.

Even (22c) is widely assumed to be true, though in the context of DO-support rather than auxiliary BE. The goal of the section 2.2, however, was to demonstrate that the overflow pattern of auxiliary use mandates an approach to auxiliary BE in these terms.¹⁸

Indeed, this general outline for a system of verbal inflection bears a certain resemblance to the classic Affix Hopping analysis proposed by Chomsky (1957): Affix Hopping proposes that inflectional morphology is generated above the verb, and that the Lowering of these affixes onto the main can be disrupted (can fail) due to the presence of intervening syntactic objects, in which case this “stranded” inflection must be realized by a default element (DO). For a number of reasons, however, I do not adopt an Affix Hopping analysis of verbal inflection here. As a syntactic process it is somewhat strange: the downward movement it invokes violates otherwise-general principles such as the Empty Category Principle, and does not have any obvious counterpart in phrasal movement. Quite besides this, however, the goal of this chapter is to propose a *general* theory of verbal inflection, unifying the distribution of auxiliary BE across languages: Affix Hopping is at odds with this project, because it assumes that the main verb remains *in situ*, which is certainly not a general property of languages with auxiliary verb constructions. The same problem would arise for an approach that assumes that verbs combine with inflectional information by head movement: just as not all languages have a verb *in situ*, they do not all have verb movement. The challenges facing movement-based approaches to verbal inflection such as Affix Hopping and head movement will be discussed in more detail in section 2.5.1.

In this section I argue that the “downward” relationship between inflection and the main verb should be framed not in terms of *movement* but in terms of *Agree* between functional heads and the main verb. Agree was proposed by Chomsky (1998) as a relationship between the abstract features of syntactic heads. As we will see in subsequent sections, independently-established limitations on Agree, in particular its *locality* requirements, map well onto the locality requirements found in the inflectional system.

¹⁸Chapter 4 demonstrates that a careful examination of DO-support, particularly in languages other than English, reveals that DO is *not* well explained as a default verb that realizes stranded inflectional material, in contrast to its analysis since Chomsky (1957). This removes what otherwise might be an obstacle to adopting this analysis for auxiliary BE.

I will argue, however, that Agree must allow “downward” transmission of feature values, contra Chomsky (1998, et seq.), in order to capture the idea that inflectional information is *introduced* on functional heads, but *realized* on the main verb. This requires a re-formulation of Agree, reversing its directionality, and consequently this chapter contributes to an increasing body of work that argues for such an alternative view of Agree (Baker, 2008; Zeijlstra, 2010; Wurmbrand, 2011, a.o.). This approach to Agree is presented in more detail in section 2.3.1.

Two forces will mitigate the locality of Agree, and give rise to variation among languages in their distribution of auxiliary BE. The first is differences among languages in which features are identified as *marked*, and thus *specified* for the purposes of the syntactic computational system. The second is the different distributions of *head movement* among languages, which is able to move the verb into a local relationship with functional heads to which its base-position was non-local.

The broader implication of this analysis is its *unification* of patterns of verbal inflection across languages, arguing that differences in auxiliary patterns arise not from arbitrary morphological properties of different languages, but from independently observable syntactic variation.

2.3.1 Verbal inflection and Agree

The syntactic analysis of this dissertation is expressed in what is broadly known as the *minimalist* framework, developed in work by Chomsky (1993, 1998, et seq.). As originally expressed, minimalism aims to account for syntactic processes in terms of *interface conditions*: where possible, it aims to reduce syntax to the properties of individual heads, and to the need of each structure to be associated with both a *pronunciation* and a *meaning*.

Within the minimalist approach, the operation that establishes relationships between syntactic objects is Agree (Chomsky, 1998). In its original formulation, Agree is triggered by the presence of *unvalued* syntactic features on a head or phrase. Chomsky (1998) argues that unvalued features are necessarily uninterpretable, and thus would violate a requirement of Full Interpretation at the interface with semantics. Because of this, he proposes, when unvalued features are Merged they search their complement for valued (and hence, for him, interpretable) features of the same type. An Agree relationship is established between the searching features (the *Probe*) and the closest c-commanded valued counterpart (the *Goal*).

The central cases motivating the formulation of Agree historically involved the relationship between functional projections in the clausal spine, such as T^0 and C^0 , and *nominal* constituents, such as subjects and *Wh*-elements. Chomsky argues that morphological subject agreement on the tensed verb, for example, results from Agree between the subject DP and T^0 for φ -features, triggered by unvalued φ -features on T^0 . In turn, this Agree relationship allows the subject to license abstract (nominative) Case features, and provides the basis for movement of the subject to SpecTP.

The cases we are interested in here, however, do not involve interaction between the clausal spine and nominal arguments, but instead the relationships established among the heads of which the clausal spine is composed. As a result, we are not interested in the manipulation of nominal agreement φ -features, which will remain entirely orthogonal to issues discussed here, but in inflectional features marking categories such as tense, aspect, mood, and voice.

Implementing an Agree-based system of verbal inflection is not totally straightforward: as several authors have acknowledged (including Adger, 2003, Pesetsky and Torrego, 2007, and Wurmbrand, 2011), verbal inflection raises questions about the basic *directionality* of Agree. As stated above, Chomsky (1998) argues that only unvalued/uninterpretable features can act as Probes. With respect to verbal inflection, this would require that inflectional features on positions such as T^0 or Asp^0 be unvalued and uninterpretable, in order to allow them to establish Agree relationships with lower heads such as V^0 .

The theoretical role of projections such as T^0 or Asp^0 , however, is to introduce inflectional information, and provide the locus of its semantic interpretation. If tense features were both valued and interpretable on V^0 , this would seem to contradict the existence of these functional heads. Something more must therefore be said about how Agree manipulates verbal inflection, if we are to preserve the view that inflection is associated with a sequence of functional projections above the verb.

One possible response to this problem of directionality, and the one I will ultimately implement in this dissertation, is to simply *reverse* the relationship established by Agree. An increasing number of authors have identified cases in which syntactic features seem to be interpreted “higher” than they are morphologically realized, cases that similarly cannot be captured by Chomsky’s formulation of Agree. This has led to various proposals of “reverse” Agree, in which feature values can be passed *downward* from the positions in which features

are semantically interpreted. This has been argued for verbal inflectional features by Adger (2003) and Wurmbrand (2011), for φ -agreement by Baker (2008) and Merchant (2011), and for negative concord by Zeijlstra (2008, 2010) and Haegeman and Lohndal (2010).

Following this work, we can define a “reverse” Agree operation as follows:

(23) *Agree*

Agree is a relationship between two features such that an unvalued feature [F:_] receives the value of a feature [F:val] of the same type iff:

- a. A head α containing [F:_] is c-commanded by a head β containing [F:val].
- b. There is no head γ containing a matching feature [F:(val)], such that γ c-commands α and β c-commands γ .

There are other moves we might make in response to the problem posed by verbal inflection for Chomsky’s original formulation of Agree. I will discuss two of these, forming the most obvious alternatives to the “reverse” definition of Agree in (23), shortly below. First, however, let us say a bit more about the way in which an Agree-based model of verbal inflection would satisfy the three requirements outlined at the beginning of this section, in particular the requirement that inflectional information (features) can *fail* to combine with the main verb.

To illustrate how the definition of Agree proposed in (23) applies to verbal inflection, consider the way tense inflection would combine with the main verb in a simple clause, taking examples from the familiar inflectional system of English:

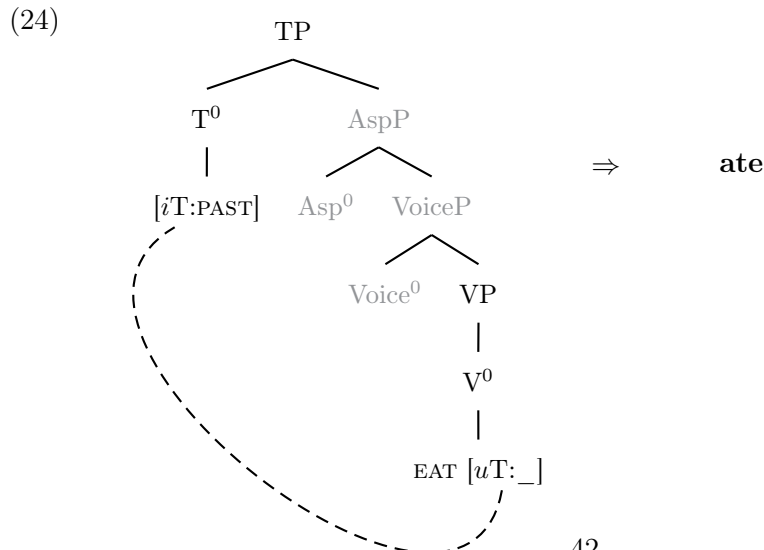

As previously discussed, the addition of another inflectional category in the progressive results in the occurrence of an auxiliary verb, reflecting the additive pattern of auxiliary use in English:

(25) The children **were eating** the cake.

Recall that in section 2.2.3 I argued that a structural account of auxiliary distribution should be stated in terms of *locality* requirements on the combination of inflection with the main verb. The auxiliary *were* in (25) would consequently reflect stranded T^0 inflection.

Agree is constrained by some form of Relativized Minimality (Rizzi, 1990, et seq.), reflected by the clause in (24b). This effect of this relativized locality in the derivation in (26) is that T^0 is required to Agree with Asp^0 rather than directly with the verb:

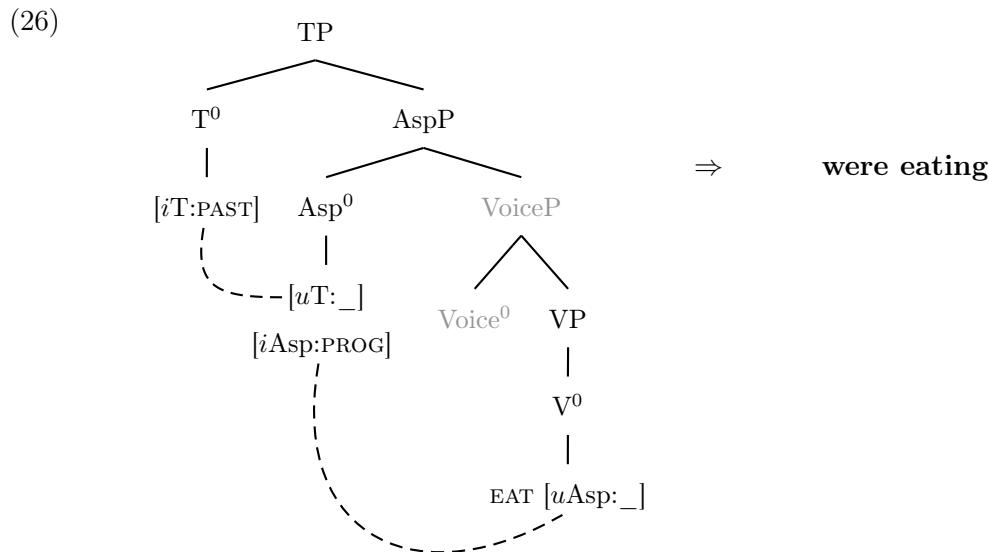

A fundamental property of Agree, however, is that it is potentially *long-distance*: relativized locality allows an Agree relation can be established at an arbitrary distance, so long as the actual target is the closest *potential* target within a c-command domain.¹⁹ We must ask, therefore, why the $[uT:_]$ feature in (26) occurs on Asp^0 rather than V^0 . Nothing proposed so far rules out a derivation such as (27) instead:

¹⁹The locality of Agree is widely taken to be constrained by the theory of phases (Chomsky, 2001, 2005), but Agree can still establish relationships between heads that are in a c-command relationship, but in which one does not immediately dominate the other.

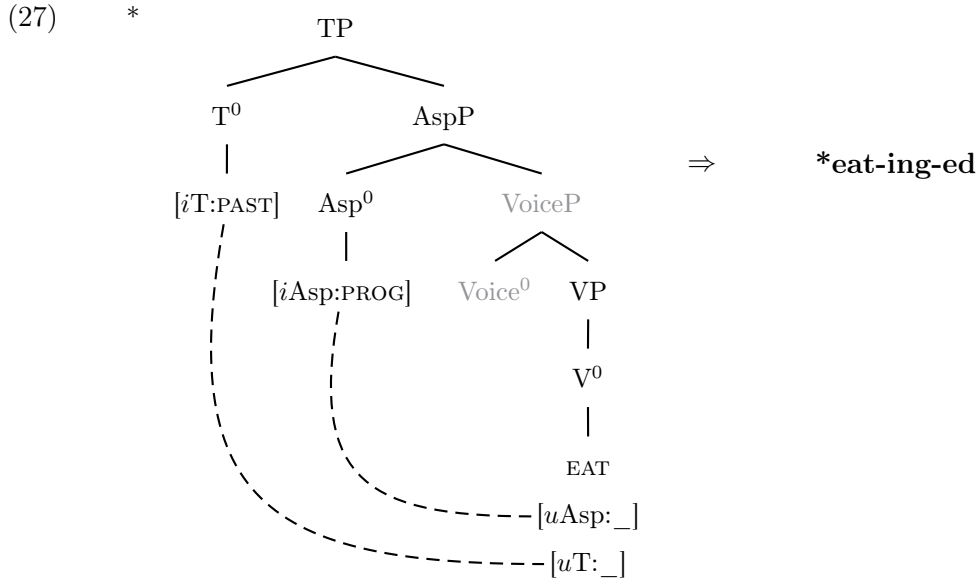

What we want to say, to rule out derivations such as (27), is that Asp^0 acts as an *intervenor* between T^0 and V^0 . For it to intervene, however, it still has to be merged with the right *kind* of features to be a target of Agree with T^0 . In other structures, we would similarly have to ensure that passive $Voice^0$ (which also triggers auxiliary insertion in English) bore a $[uT: _]$ feature so that it would intervene between T^0 and V^0 , but that the same passive $Voice^0$ bore $[uAsp: _]$ in the progressive passive, so that it would in turn intervene between Asp^0 and V^0 .

In general, we would need an articulated theory of where inflectional features could be merged, in order to ensure that each inflectional head would bear the right features to be a target of the head immediately above it. In many respects this would involve *replicating* clausal structure in the theory of where unvalued features are merged.²⁰

An approach that vastly simplifies the proposal that inflectional heads all act as intervenors for the purposes of inflectional Agree is that all inflectional features are of a single *type*. I adopt here the proposal of Adger (2003) that there is a general feature $[INFL: val]$, which can have values $[INFL: PAST]$, $[INFL: PRES]$, $[INFL: IMPF]$, $[INFL: PASS]$, etc.

We can now state the distribution of targets of inflectional Agree relatively simply: verbs are merged with an unvalued inflectional feature ($[uINFL: _]$), and any head with a valued inflectional feature **also** carries $[uINFL: _]$.²¹

²⁰This issue would also arise in an Agree-based framework where auxiliaries are projected in the syntax: why does the presence of inflectional features on Asp^0 prevent features of T^0 from being realized on V^0 ?

²¹The exception is that the highest inflectional head in a clause, generally T^0 , must bear only a valued

The operation of reverse Agree, together with this generalized approach to inflectional features, is illustrated in (28), where dashed lines indicate Agree relations.

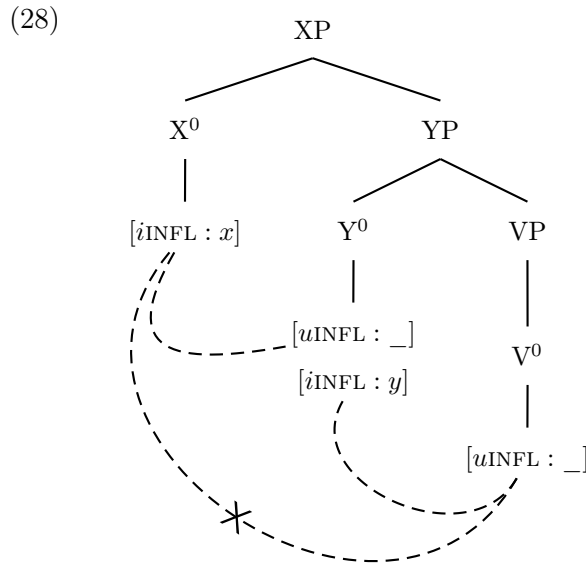

The fact that the inflectional feature of X^0 does not Agree with a target on V^0 , I propose, represents a context in which inflectional features are “stranded” and trigger the insertion of an auxiliary verb. I turn to the mechanism of this insertion in section 2.3.6, where I argue that it is the *morphological* component that requires the insertion of auxiliary BE in such contexts.

I have so far focused on defining reverse Agree in a way that can capture the locality required of a system of verbal inflection in which auxiliaries result from stranded inflectional features. This locality, framed in terms of relativized minimality, is independent of the directionality of Agree, however.²² I have argued that Chomsky’s original formulation of Agree, which requires that feature values originate in a low clausal position, is incompatible with the view that inflectional information is *interpreted* in positions higher than the main verb. One possible response to that incompatibility is reversing the direction in which feature valuation takes place, as outlined above.

inflectional feature. Alternatively we could suggest that unvalued inflectional features do not actually result in a derivational crash, but instead act only as *triggers* for Agree when it is possible.

²²In fact, the application of a relativized-minimality form of locality to verbal inflection is independent of an Agree-based mechanism altogether. In place of “reverse” Agree, we could easily define a new operation that enforced relativized minimality without involving any feature *valuation* (integral to Agree itself). This new mechanism could, for example, *assign* feature values introduced on a higher functional head to a lower head, provided that (a) the lower head is an appropriate target for the features to be transferred, and (b) there is no *closer* potential target for the features to be transferred to. Such a mechanism would move a feature-based approach to verbal inflection closer to the traditional analyses of Affix Hopping or Lowering.

There are at least two alternatives that attempt, in different ways, to reconcile the directionality of Agree proposed in Chomsky (1998) with the view that inflectional information is associated with functional heads above the verb. The first of these is the proposal the downward transmission of inflectional features accompanies, and is dependent on, an Agree relation triggered by other unvalued features of the inflectional functional head. The second is developed in Pesetsky and Torrego (2007), who develop an account of verbal inflection in which inflectional features are *interpreted* on functional heads but *valued* on the main verb (building on their earlier work). The remainder of this section discusses these alternatives, but ultimately argues that a reverse form of Agree presents a more natural approach to auxiliaries and to verbal inflection more generally. More general arguments in favour of reverse Agree, and discussion of its broader implications, is left until section 2.5.

Let us begin by discussing the proposal that the valuation of a verb’s inflectional features is *dependent* on Agree for some other feature. This is an extension of current accounts of Case valuation as resulting from φ -agreement: heads such as T^0 and v^0 are merged with unvalued φ -features, which cause them to probe downwards for a nominal argument. The unvalued Case features of nominal arguments are in turn valued as a *reflex* of this Agree relation.

Similarly, the presence of an unvalued and uninterpretable feature [$uF: _$] on a functional head X^0 could probe and establish an Agree relation with a corresponding feature on V^0 , as in (29) (where the Agree relationship is indicated by the dashed line). On the *basis* of this Agree relationship, V^0 ’s unvalued inflectional feature could be valued by the valued and interpretable inflectional feature of X^0 :²³

It is the second of these requirements that imposes a relativized form of locality. It is this kind of locality that will play a key role in the account of auxiliary verbs developed in this chapter.

It is only theoretical parsimony that militates in favour of reformulating Agree, rather than proliferating syntactic mechanisms, particularly syntactic mechanisms that share most of their properties (manipulating abstract features, being subject to the same forms of locality, etc.). Were there strong empirical or conceptual arguments against the application of Agree in the inflectional domain, we would be justified in proposing a new operation, but I present no such arguments in this chapter. Indeed, from one perspective this section can be viewed as an extended argument that novel syntactic mechanisms are *not* required to account for verbal inflection and auxiliaries, particularly given the growing literature arguing in favour of “reverse” Agree. It is nonetheless possible that further investigation in these domains will reveal arguments against a valuation-based mechanism such as Agree.

²³On most accounts, this is not exactly how Case valuation occurs. Instead of Case being valued by corresponding features of T^0 , v^0 , etc., uninterpretable Case features are valued simply as an indication that a DP has Agreed with a Case-licensing head. The exception to this is work such as Pesetsky and Torrego (2002, et seq.), who propose that Case is actually the reflex of inflectional feature values on DP arguments.

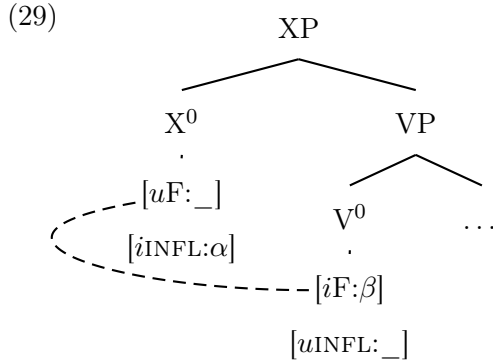

Cowper (2010), for example, proposes that inflectional heads bear uninterpretable subcategorization features, which establish an Agree relation with the verb, providing the basis for downward transmission of inflectional features.

This proposal does not create problems in cases where a single inflectional head, such as T^0 , Agrees directly with V^0 . A problem does arise, however, when two intermediate inflectional projections Agree with one another. Consider (31), a sub-structure of an English progressive passive such as (30):

(30) A board game is being played (right now).

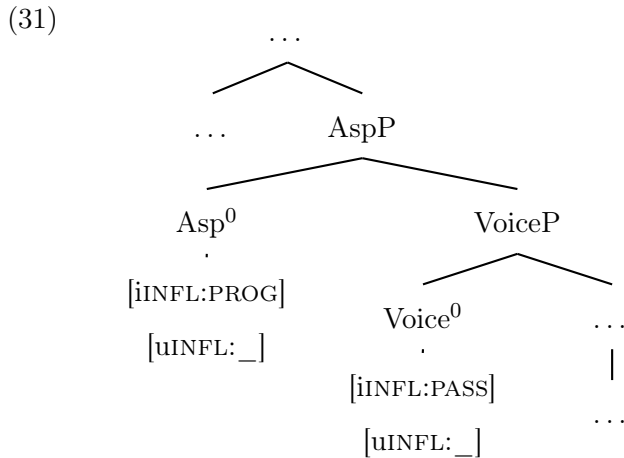

The intermediate projections Asp^0 and $Voice^0$ in a structure such as (31) both have both valued and unvalued inflectional features, reflecting the fact that $Voice^0$ prevents Asp^0 from Agreeing directly with the main verb (and Asp^0 similarly prevents T^0 from Agreeing with lower heads). This assumes that $Voice^0$ can be the target for inflectional Agreement with Asp^0 .

Assume, however, that the $[iINFL: PASS]$ feature has already Agreed with an equivalent

feature on V^0 . Now Asp^0 Probes, triggered either by its own unvalued INFL feature or by some other unvalued feature as in the tree in (29). If the establishment of any Agree relationship between two positions allows valuation to proceed in both directions, however, then the once, then once an Agree relation is established between Asp^0 and $Voice^0$, should result in Asp^0 's own unvalued INFL feature being valued as [INFL:PASS]. In fact, we do not seem to ever find this kind of “upward” transmission of inflectional values among the inflectional functional heads in a clause.

Allowing downward transfer of inflectional feature values to be *dependent* on an Agree relationship established by some other unvalued feature of an inflectional functional head thus encounters problems in clauses with sequences of such heads – i.e. clauses in which stranded features will give rise to auxiliary verbs.

The second possible modification of Agree represents more of a departure from Chomsky's original formulation. This modification is proposed by Pesetsky and Torrego (2002, 2006, 2007), who distinguish the interpretability of features from their valuation. Pesetsky and Torrego claim that features can act as Probes when they are unvalued, independently of whether they are interpretable or uninterpretable. This allows Agree to be triggered by *unvalued but interpretable* features. They also propose that Agree results in feature identification: when two distinct features Agree, they are *identified* and become two instances of a single feature.

In the context of verbal inflection, this allows them to propose that T^0 has tense features that are *interpretable* but *unvalued*. *Valued* tense features will be merged on V^0 , where they are *uninterpretable*. Agreement of the two feature instances results in their identification.

Pesetsky and Torrego apply this proposal only to the interaction of a single functional head – T^0 – with an inflected main verb. This approach is motivated, to a certain extent, by a *lexicalist* approach to morphology: if lexical items are inflected prior to the syntactic derivation, it is natural to propose that an inflected verb such as *ate* has (uninterpretable) past tense features that must be licensed by a relationship with T^0 , just as it is natural (on a lexicalist approach) to propose that an inflected verb such as *eats* has uninterpretable third-person and singular ϕ -features that must be licensed by a relationship with the subject (mediated by T^0).

In a post-syntactic approach to morphology like the one adopted in this dissertation, however, Pesetsky and Torrego's approach is less natural: on such an approach, the mor-

phological system cannot be responsible for the presence of uninterpretable past tense features on the verb, because the morphological system merely *interprets* the output of syntax. Proposing that an abstract lexical root EAT is merged to the syntactic derivation with uninterpretable past features, which will ultimately Agree with T^0 and result in the verb being spelled out as *ate*, contradicts the spirit of an interpretive morphology, by pre-determining what the inflectional results of the syntactic derivation would have to be.

The complexity of the pre-determination required by Pesetsky and Torrego's system becomes clearer once we extend their proposals to cases in which multiple inflectional heads interact. Consider a clause with interacting heads T^0 , Asp^0 , and V^0 . Pesetsky and Torrego's system assumes that the inflectional *values* of T^0 and Asp^0 are merged in lower positions, on Asp^0 and V^0 respectively. It is crucial that these inflectional features be merged in the correct positions, in order for Asp^0 to end up with aspectual features, and for T^0 to end up with tense features, or else the derivation will crash. A more elegant theory would be one in which no conspiracy of factors is necessary for inflectional features to be successfully associated with the positions in which they are interpreted.

Were we to instead adopt a lexicalist approach to morphology, these conceptual objections to Pesetsky and Torrego's approach would be substantially lessened. However, the post-syntactic approach to morphology adopted in this dissertation is the most naturally compatible with the view that auxiliary verbs are morphological "repairs", the approach I have argued is required by the overflow pattern of auxiliary use. This motivates the choice of reverse Agree in place of the Pesetsky and Torrego system, and the analysis proposed in this dissertation will be framed in those terms. In sections 2.3.2 and 3.4.3, however, we will see some additional points at which the Pesetsky and Torrego system faces challenges that do not apply to reverse Agree.

A final conceptual advantage of reverse Agree is that it reflects the intuitions of earlier approaches to inflectional morphology such as Affix Hopping or head movement: that inflectional information originates higher than the main verb, and must somehow combine with the main verb from that position. Below I illustrate how this basic approach applies to the familiar additive pattern of English verbal inflection.

2.3.2 Unspecified heads, visibility, and “markedness”

In the discussion of relativized minimality and the ability of all inflectional heads to act as intervenors for inflectional Agree, I assumed without comment that certain values of inflectional functional heads – non-progressive Asp^0 , and active Voice^0 – were not specified for inflectional features, and consequently did not act as intervenors. In the absence of this implicit assumption, we would predict that the only features that should ever be expressed on an *in situ* verb would be those of the most local functional head, Voice^0 for example.

This section articulates more carefully the sense in which certain values of certain features are *non-visible* for the purposes of Agree, simply because these feature values are not syntactically specified. Heads with such features may be involved in the composition of semantic meaning – conceivably they could also be pronounced – but will not be targetable by Agree.²⁴

The intended concept of *visibility* is closely related to the long-standing literature on markedness, originating in the structuralist approach to phonology of the Prague school (particularly the work of Trubestkoy) and extended to morphological, syntactic, and semantic feature oppositions in the work of Jakobson (1939, et seq.). Markedness theory assumes not only that language is built on a series of (generally binary) oppositions, but that these oppositions are intrinsically *asymmetric* (Jakobson, 1939, among others), with one member of an opposition being specified, or *marked*, while the other is indicated only by the absence of that distinctive specification, i.e. *unmarked*. Applied to feature visibility, we can say that the visible value of a feature would be marked by the presence of a feature, while the invisible value would simply be the absence of that feature.

This simple idea of abstract specification and non-specification, however, is abandoned in many discussions of morphological markedness, including in the domain of aspect and other inflectional categories.

Going back to work by Jakobson, work on markedness has often argued – or at least assumed – that morphological and semantic markedness go hand in hand (Jakobson, 1939, Greenberg, 1966, Olsen, 1997, among others; though cf. Comrie, 1976, 114, Dahl, 1985, 19). Part of the reason for this may be that morphological markedness is easy to identify:

²⁴At present, our concern is only with the (in)visibility of *inflectional* features. Because (in)visibility is a property of *features*, rather than of heads themselves, it is possible in principle that a head could be visible for the purposes of some Agreement relations, but invisible for the purposes of others.

a category is marked with respect to another if it has some additional overt morphological element. Semantic markedness, by contrast, is more abstract: it has been presumed that an unmarked category will have a more general meaning than a marked one, and that the meaning of the unmarked category will *encompass* the marked category (Jakobson, 1939; Greenberg, 1966). To use an example from the domain of aspectual semantics, in languages that have both a progressive and a general imperfective, the progressive is generally more morphologically marked than the imperfective, and it is also the case that the meaning of the imperfective *includes* the meaning of the progressive (Comrie, 1976).

What is missing in work that assumes that all featurally “unmarked” categories must be morphologically unmarked is a recognition of the idea that *default* or *elsewhere* morphemes can be non-zero. In any morphological system that includes the concept of an *elsewhere* form, there is no reason to expect that unmarked features would result in null morphology. Indeed, there are a variety of cases in certain inflectional morphology seems to occur for reasons of morphological (or morphophonological) well-formedness, precisely in the *absence* of features that would mandate more specific inflection. Representative examples include masculine agreement morphology apparently in the absence of masculine *features* being syntactically specified (see, for example, (Merchant, in progress)); the appearance in many languages of masculine singular agreement morphology on verbs that fail to agree with a nominal argument (Preminger, 2009); the default “final vowel” morpheme in the verbal morphology of many Bantu languages, which occurs across a non-homogeneous set of environments in which more specific morphemes are not required (Nurse, 2003, 2008). The Distributed Morphology approach I adopt in section 2.3.6 permits this form of “elsewhere” inflection in the absence of any specified inflectional features.

This concept of default or elsewhere morphology allows featurally unmarked categories to nonetheless occur with characteristic morphology – morphology that is characteristic of the *absence* of more specific features. Morphology associated with an unmarked or default category should surface in contexts in which we do not expect *any* specification for a particular opposition: for example, we might expect to find default aspectual morphology in contexts where (syntactically speaking) there is no source for aspectual features.²⁵

This intersects with a different criterion of markedness, that of *neutralization*. As Comrie

²⁵This appears to be the case in counterfactual clauses, for example, where many languages employ apparently default imperfective morphology that is nonetheless compatible with perfective interpretations (Iatridou, 2000, 2009).

(1976) observes, neutralization was key to structuralist definitions of markedness in phonology: in contexts where an opposition is neutralized (never realized), and no contextual factors appear to determine which sound occurs, the sound that occurs was defined to be the unmarked member of the opposition. In the case of voicing contrasts in German, for example, the contrast between voiced and unvoiced stops is not maintained word-finally. In such contexts, it is the unvoiced member of the pair that is preserved, and so unvoiced stops would be unmarked relative to their voiced counterparts.

Independently of this original application in phonological contexts, in the context of inflectional features we can propose that the default member of an opposition – the member that is not reliant on positively specified syntactic features, i.e. the one that is invisible – is the one that appears in contexts where the contrast is not maintained.

In the case of aspect, one such context is the aspect that occurs on aspectual auxiliaries themselves. That is, the aspect realized on aspectual auxiliaries can be said to be unmarked. This criterion will be useful in subsequent sections in identifying the unmarked member of an aspectual opposition. In Romance languages, for example, the perfective auxiliary itself occurs in a simple present form, which in isolation would be interpreted imperfectively, while the past perfective auxiliary is used is the imperfective past form. This lends support to the view that imperfective morphology does not depend on the presence of specifically imperfective syntax or features, and thus to the view that the imperfective is a default aspectual value, and that [INFL:IMPF] features are not syntactically visible.²⁶

Crucially, however, languages do differ in which members of an opposition they treat as marked and unmarked, though strong cross-linguistic trends can be found. Thus, with regards to aspect, we find perfective-default and imperfective-default languages, though with regards to tense most languages appear to be present-default. Evidence for the default status of imperfective or perfective aspect arises in environments such as those just discussed, such as the aspectual inflection observed on aspectual auxiliaries themselves.

Returning to the intersection of feature (non-)specification and Agreement, we expect that heads without specified inflectional features will *not* act as intervenors, and will allow Agreement to occur across them, as schematized in (32):

²⁶In several Romance languages (including Spanish, French, and Italian), past perfective (pluperfect) auxiliaries do occur in their past perfective forms in adverbial adjunct clauses. Given the availability of these forms, it is particularly striking that auxiliaries always occur in imperfective forms in main clause contexts.

(32)

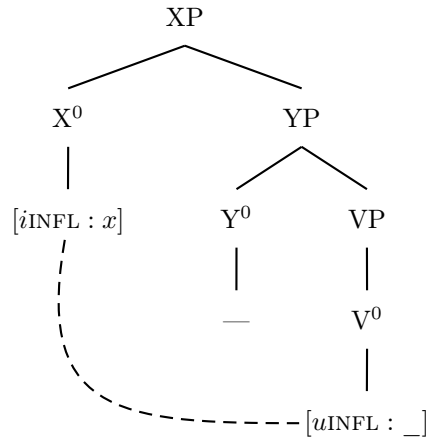

A head without specified inflectional features will never act as an intervenor for Agree, simply because it contains no information that could potentially be a Goal of Agree.

The view that certain inflectional values are “unmarked” provides another argument against the view that inflectional feature *values* are introduced below inflectional functional heads themselves, as required by Pesetsky and Torrego’s system. Key to Pesetsky and Torrego’s proposal is the idea that functional heads “learn” their values by establishing a relationship with a lower head: T^0 , for example, is only past or present by virtue of the value introduced on the main verb. Consider, however, how an *unmarked* inflectional value would be represented in this system. It would have to be the case that unmarked Asp^0 was the result of a default interpretation mechanism, when Asp^0 has failed to Agree with another position from which it acquires a marked aspectual value. This requires, first of all, that unvalued but interpretable features are not derivationally problematic, but can be supplied with default interpretations. It *also* requires, however, that inflectional features are *not* all of the same general type. The reason is that if “unmarked” Asp^0 bears a general unvalued feature $[INFL: _]$, it will always receive a value from any lower inflectionally valued head, intervening between that lower head and higher functional heads such as T^0 . Unmarked aspect thus could not simply be the result of the failure to value an interpretable feature on Asp^0 , it would have to involve not providing Asp^0 with an interpretable feature in the first place. In effect, therefore, *unmarked* values would be introduced on their associated functional heads (though by the failure to merge any inflectional feature in that position), while *marked* values would be determined only by Agree in the course of the derivation.

This problem could be resolved by the proposal that inflectional features are *not* all of the same type, but this would run into the same problems reviewed in section 2.3.1.

Consequently, the idea that some inflectional values are featurally unspecified, though semantically interpreted, indirectly argues in favour of the view that inflectional feature values are introduced on their associated functional projections, an approach implemented here via reverse Agree.

2.3.3 Interim summary

In section 2.2 I observed that auxiliary BE appears to occur in order to realize features that are *structurally distant* from the main verb. I argued that the overflow pattern of auxiliary use strongly suggests that auxiliary BE occurs to realize inflection that was structurally unable to combine with the main verb: i.e. “stranded” inflection.

Implementing this proposal requires a model of verbal inflection in which it is possible for inflectional features to fail to combine with the main verb, for reasons *other* than the presence of intervening verbs – i.e. syntactically selected auxiliaries. In this section I have proposed that verbal inflection is generally manipulated via Agree, but a form of “reverse” Agree, whose definition is repeated from (23) in (33):

(33) *Agree*

Agree is a relationship between two features such that an unvalued feature [F:_] receives the value of a feature [F:val] of the same type iff:

- a. A head α containing [F:_] is c-commanded by a head β containing [F:val].
- b. There is no head γ containing a matching feature [F:(val)], such that γ c-commands α and β c-commands γ .

By proposing that all inflectional features are different *values* of a single feature *type*, the relativized locality of Agree will prevent inflectional functional heads from establishing an Agree relationship directly with the verb across another inflectional functional head, as illustrated in (34), repeated from (28):

(34)

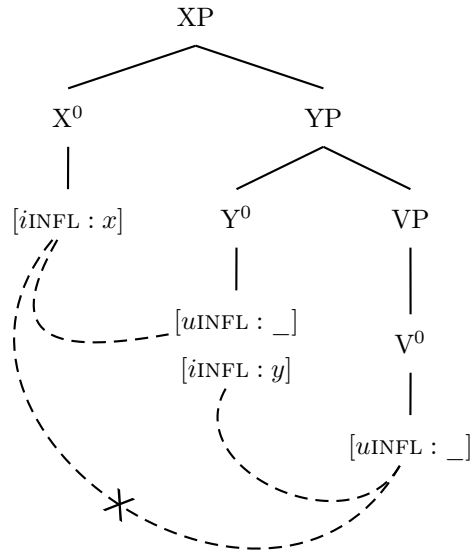

If the intervening head Y^0 in (34) were *not* specified for inflectional features, however, it would not disrupt Agree between X^0 and V^0 . I argued in section 2.3.2 that unmarked or default feature values are unmarked in exactly this way, and that languages *differ* in which feature values they specify and which they do not.

In the next section I illustrate how the system proposed so far is sufficient to account for the familiar additive pattern of English, and the relatively simple overflow pattern of Arabic.²⁷

2.3.4 Illustration: English and Arabic

The model of verbal inflection developed so far is able to account for patterns of auxiliary BE in several of the languages mentioned in section 2.1. This section illustrates the model more concretely by showing how it applies to the patterns of English and Arabic.

The relatively familiar pattern of auxiliary use in English is the first topic, before turning to the overflow pattern found in Arabic. I show that the same system that correctly generates the additive pattern of English generates the overflow patterns of Arabic without further modification, once we adopt the independently-justified assumption that Arabic (in contrast to English) not only has unmarked (and thus featurally unspecified) values for aspect, but also an unmarked value for tense.

²⁷The account of Latin requires explication of how head movement interacts with the system of verbal inflection, and is delayed until section 2.3.5.1. Discussion of Kinande, Finnish, and Basque, the other languages discussed in section 2.1, is delayed until section 2.4, where their inflectional systems can be discussed at greater length.

2.3.4.1 English

English exhibits an additive pattern of auxiliary use. Recall that the additive pattern of auxiliary use is one in which certain categories appear to uniformly “come with” an auxiliary. The relevant cases in English involve the progressive and the passive. Both these inflectional categories require a *be* auxiliary independently, and the combination of both in the progressive passive triggers the occurrence of two auxiliaries:

- (35) a. The children **were** eating the cake.
 b. The cake **was** eaten.
 c. The cake **was being** eaten.

Within the framework developed here, all that is necessary to account for this pattern of auxiliary use is to assume that English has only one marked value for Asp^0 (progressive aspect: [INFL:PROG]) and only one for Voice^0 (passive: [INFL:PASS]), but that it marks *both* present and past tense ([INFL:PRES] and [INFL:PAST]). Non-progressive Asp^0 and active Voice^0 will be unspecified for inflectional features, and therefore non-visible for purposes of Agree.

When neither Asp^0 nor Voice^0 contains specified inflectional features, T^0 will be able to Agree directly with V^0 . This is represented by the tree in (36):

- (36) The children ate the cake.

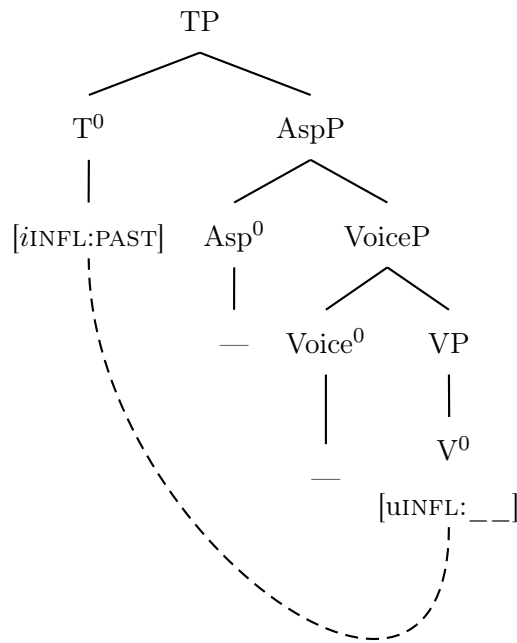

The [INFL:PAST] feature originating on T^0 Agrees with V^0 . It must be morphologically interpreted in that lower position, because the English verb remains *in situ*. This can be generalized to all cases in which inflectional features Agree with a lower position, as in (37):

(37) *Morphological realization of inflectional features*

In a sequence of inflectional features $[F_1], [F_2], \dots, [F_n]$ are related by Agree, such that each feature $[F_i]$ c-commands $[F_{i+1}]$, it is the last feature in the sequence (the structurally lowest) that is morphologically realized.²⁸

Now we turn to the appearance of single auxiliaries in the progressive and the passive. In the progressive V^0 Agrees with Asp^0 , across the non-visible $Voice^0$, but remains *in situ*. T^0 then Agrees with Asp^0 , but is unable to Agree with the main verb, for reasons of locality.²⁹

In the simple passive, V^0 similarly Agrees with $Voice^0$ but does not move. T^0 is able to Agree with $Voice^0$ across the intervening non-visible Asp^0 , but does not Agree directly with V^0 .

(38) a. **were eating** (Progressive)

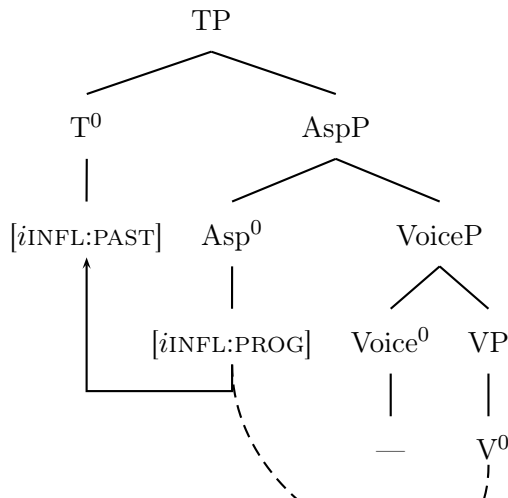

²⁸This chapter has focused on cases in which only *two* inflectional features are involved in a chain of Agree relationships, for which a condition on pronunciation could be stated more simply. Consider, however, the distribution of φ -features that ultimately Agree with a clausal subject: on standard accounts, uninterpretable φ -features must occur on both T^0 and V^0 (in clauses with a finite main verb), yet they are pronounced only on V^0 (like tense inflection). As a result, we cannot express the morphological realization of features either as a pair-wise condition (i.e. *pronounced on the lower of two positions that Agree*), nor can we say that features are morphologically interpreted whenever they are not semantically interpreted (otherwise subject φ -features would be pronounced not only on V^0 but also on T^0).

²⁹An empirical argument for (37), involving the relative positions of non-finite progressive and passive auxiliaries, appears in section 2.3.6.

b. **was eaten** (Passive)

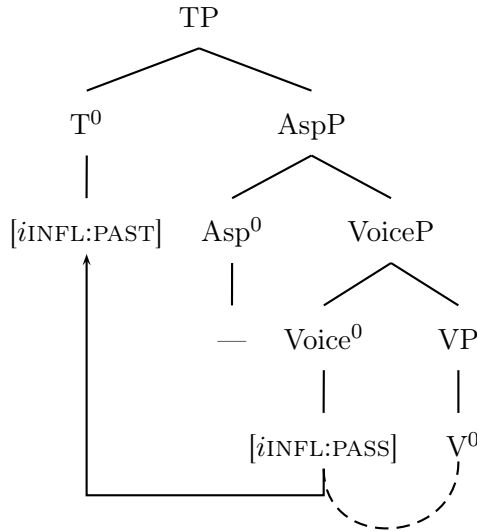

In both these structures the $[i\text{INFL:PAST}]$ feature of T^0 is stranded: it does not occur on a head that contains V^0 . I have proposed that such stranded features trigger the insertion of an auxiliary BE. The details of this insertion are the topic of section 2.3.6.

For now, the principle in (37) suffices to state the position in which features are morphologically realized, and thus the position in which a default auxiliary BE would be inserted. Due to this principle, we would expect the $[i\text{INFL:PAST}]$ feature of T^0 in both (38a) and (38b) to be morphologically realized – via the insertion of an auxiliary BE – in Asp^0 or Voice^0 , respectively. Tensed auxiliaries in English occur in a uniformly higher position, however, following Emonds (1978) and much subsequent work. I therefore assume that both Asp^0 and Voice^0 move to T^0 in English, and consequently that any stranded features on these heads are likewise realized in T^0 .³⁰

The progressive passive, in contrast to these examples, involves *two* instances of BE. The system as developed so far predicts two instances of stranded inflectional features. As the lowest inflectional head in the system, Voice^0 is able to Agree directly with V^0 , but as elsewhere V^0 will remain *in situ*. Asp^0 then Agrees with Voice^0 but not V^0 ; the $[u\text{INFL:PROG}]$ feature resulting on Voice^0 is *stranded*, and will trigger realization as *being*. T^0 in turn Agrees with and attracts Asp^0 ; $[i\text{INFL:PAST}]$ features are realized as auxiliary

³⁰As explicated further in section 2.3.5, I assume that head movement, like phrasal movement in Chomsky (1998), is dependent on an independently-established Agree relationship between two positions. Accordingly, the generalization for English would be that Agree between T^0 and either of Asp^0 or Voice^0 is accompanied by head movement. The apparently low position of tensed *main* verbs in English, by contrast, results from V^0 remaining *in situ* in all environments. The interaction of head movement with inflectional Agree is discussed at further length in section 2.3.5, with attention to cases in which head movement interacts with the locality condition on Agree.

was in the position of T^0 :

(39) **was being eaten** (Progressive Passive)

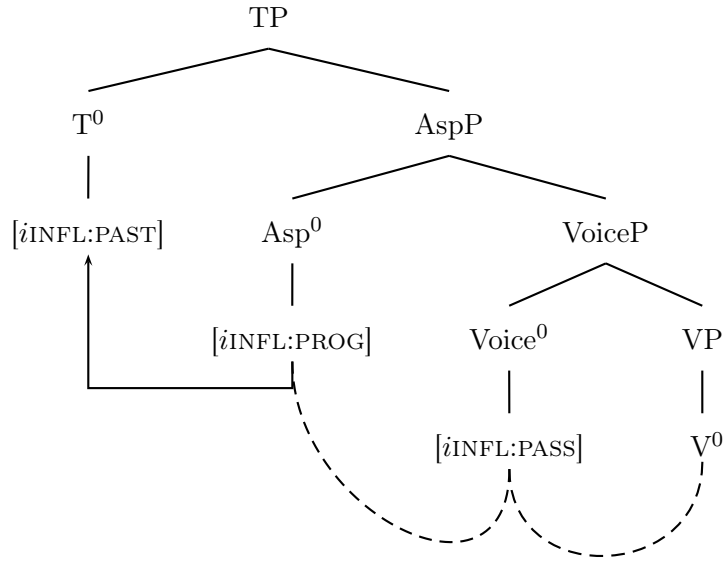

Something must now be said about the fact that these auxiliaries appear in infinitive clauses with *to*, below modal verbs, and also in imperative clauses. In these contexts there are no present or past tense features assigned by T^0 , and so we might expect the ‘highest’ auxiliary not to occur.

In order to account for the fact that auxiliaries do in fact appear in these contexts, I must assume that non-finite inflectional features, which in English result in a uniformly ‘bare’ realization, are in fact assigned in these contexts; this view may receive support from the fact that verb stems do show specific non-finite morphology in such contexts in languages other than English. In the Romance languages, for example, non-finite verbs are marked by an overt infinitival suffix, rather than corresponding to a bare uninflected form.³¹ Assuming that a modal such as *will* is merged in T^0 , we would therefore find a representation such as (40):³²

(40) **will be being eaten** (Future Progressive Passive)

³¹As we will see in sections 2.4.1 and 2.3.4.2, cases of T^0 that do not assign *any* inflectional features give rise to the overflow patterns of Kinande and Arabic.

³²The base position of modals is somewhat tangential to this analysis. Here I have adopted the traditional assumption that they are generated in T^0 . An increasing number of authors propose that modals are generated in some other position, or that epistemic and deontic modals are distinguished by their syntactic position. The analysis proposed here would not be affected by such proposals, so long as English modals originate higher than other inflectional functional heads.

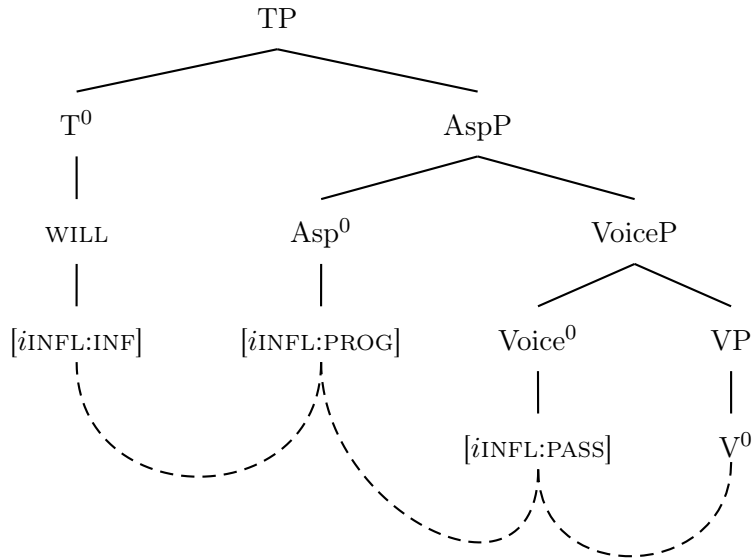

It is possible that different inflectional features are assigned, for example, in imperative contexts, though in English there is no direct morphological evidence for such a distinction. What a tree such as (40) represents, however, is the possibility that inflectional features are assigned by heads that themselves will be spelled out with over phonological content.

A complication introduced by a feature such as [INFL:INF] is that it is not obvious that they are in fact interpreted in the position of the modal or non-finite *to*. This raises the question of whether a better name for these features can be found, or whether it is possible for inflectional features not to be interpreted in *any* of their positions of occurrence.³³

The proposed system is also able to capture certain relatively recent changes in the auxiliary patterns of English. The two-auxiliary progressive passive discussed above is a comparatively recent innovation in English. Until roughly the beginning of the 17th century, the meaning of the progressive passive appears to have instead been expressed by the *passival* (Visser, 1969, §1872-1881), in which auxiliary *be* was immediately followed by a present participle, but the argument structure is that of a passive:

- (41) a. The cake was eating.
 b. the baize... was actually forming into a curtain by the house-maids.³⁴
 c. A man whose tooth was pulling out.

³³One possibility, if inflectional features represent a kind of *licensing* relationship between heads in the clausal spine, is that it is indeed possible for there to be inflectional features with no interpretable counterparts, much as it has been proposed that abstract Case features are never themselves interpretable.

³⁴1814 Jane Austen, *Mansfield Park* (London, 1897), 116, cited by Visser (1969, §1180))

The loss of the passival, and the rise of the progressive passive, is the topic of recent work by Cowper and Currie Hall (2011). They argue that this change is linked to the contemporary loss of the resultative *be*-perfect in English, which occurred at roughly the same time. The *be*-perfect was also attested with non-passive (primarily unaccusative) predicates as in (42):

(42) The coach is arrived.

Cowper and Hall argue that Early Modern English lacked specifically passive morphology, but instead had two possible values of Asp^0 : resultative and progressive. Each of these aspectual values could embed either an active or a passive structure. What caused the loss of the resultative *be*-perfect, as well as the loss of the passival, was a re-analysis of resultative *-en* morphology as specifically *passive* morphology, with the result that the two aspectual values (resultative and progressive) could no longer be analyzed as being potentially active or passive.

(43) Inflectional Contrasts: Early vs. Contemporary Modern English

	Early ME	Contemporary ME
Aspect:	Resultative (<i>-en</i>)	Progressive (<i>-ing</i>)
	Progressive (<i>-ing</i>)	
Voice:	<i>not morphologically marked</i>	Passive (<i>-en</i>)

Framed in terms of the analysis developed here, what we can say is that prior to the change posited by Cowper and Hall, English had no inflectional features associated with Voice^0 , and that this projection was therefore non-visible for the purposes of inflectional Agree. By contrast, this stage of English had *two* possible inflectional values for Asp^0 (in addition to unspecified Asp^0), either of which could select either active or passive Voice^0 . This assumes that a *semantic* distinction in Voice^0 is possible in the absence of any *inflectional* contrast:

(44) a. Early Modern English Passival: *The cake was eating* (= was being eaten)

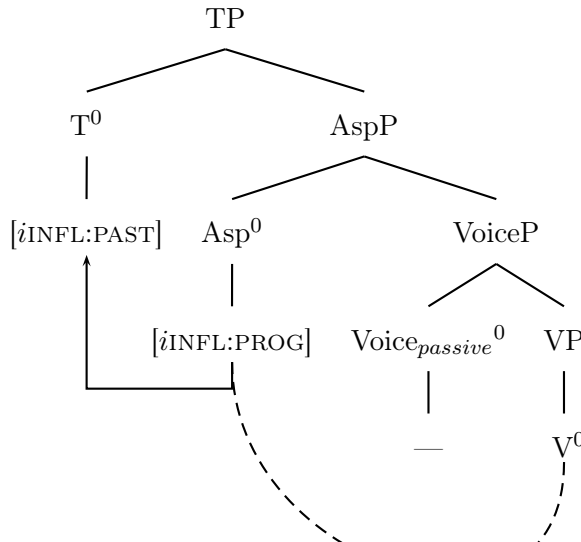

b. Early Modern English “Passive” (Resultative): *The cake was eaten*

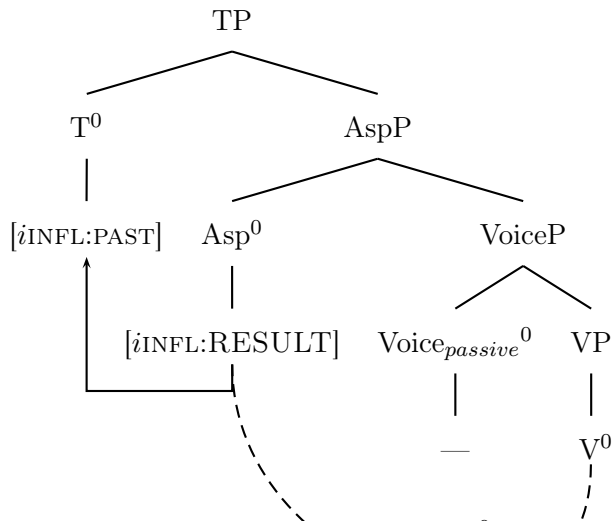

From this stage, the *-en* of the resultative Asp^0 was re-analyzed as representing a new inflectional feature $[\text{iINFL:PASS}]$ located in $\text{Voice}^0_{\text{passive}}$, while the resultative meanings expressed by *-en* would have been collapsed to the separate *have*-perfect (which I assume is associated with a higher Perf^0 projection).

The introduction of visible inflectional features in Voice^0 would have automatically led to a multiple-auxiliary structure in the progressive passive, as progressive Asp^0 would no longer Agree directly with V^0 across the (featurally) inert intervening passive Voice^0 . The analysis developed here is thus directly compatible with Cowper and Hall’s analysis of this historical shift.

Any selectional account of auxiliary use, by contrast, would require two changes to have gone hand-in-hand in the development from the passival to the progressive passive: not only

the featureal re-analysis of the past participle morphology, but also the change to Voice^0 and Asp^0 *both* selecting an auxiliary verb.

To conclude, the discussion of English in this section has been intended to illustrate that the system as developed is able to describe the attested auxiliary pattern in a language with an additive pattern of auxiliary use. This does not represent an empirical advantage of the framework, however, as languages with an English-type pattern have been the focus of all work on auxiliary verbs. The next section turns to the overflow pattern of Arabic, for which a default-auxiliaries approach is, as argued in section 2.2, empirically necessary.

2.3.4.2 Arabic

In Arabic, in contrast to English, we find an overflow pattern of auxiliary use. The examples provided in this section are drawn from Standard Arabic, but the same patterns can be found across many other varieties. In (45), repeated from (13), we see that there are simple (non-auxiliary-using) imperfective and past forms, but the past imperfective requires an auxiliary verb:

- (45)
- a. darasa
study.PAST.PFV.3SGM
“He studied.”
 - b. ya-drusu
3M-IMPF.study
“He studies.”
 - c. kaana ya-drusu
be.PAST.3SGM 3M-IMPF.study
“He was studying / He used to study.”

I propose that the absence of an auxiliary in either (45a) or (45b) is due to the fact that in both the simple past and the present imperfective there is only one functional head specified for inflectional features. That is to say, both present T^0 and perfective Asp^0 are unspecified, and therefore contain no features that could either be stranded, giving rise to an auxiliary, or block other features from Agreeing directly with V^0 .

The tree in (46) illustrates the proposed derivation for a simple past form: I have just proposed that in such a sentence T^0 is specified as [INFL:PAST], but perfective Asp^0 is *not* specified for inflectional features, i.e. that perfective is a default aspect in Arabic.

(46) Simple Past (first attempt)

darasa
study.PAST.PFV.3SGM

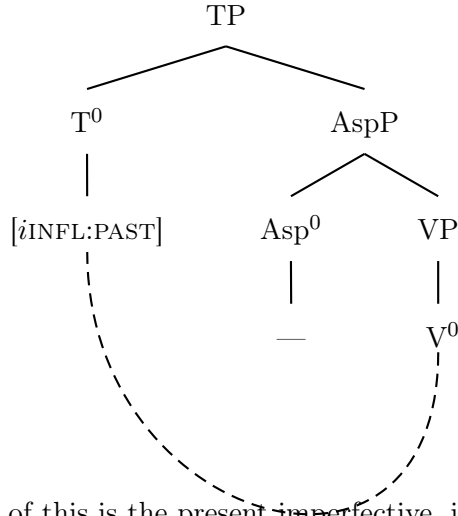

The reverse of this is the present imperfective, illustrated in (47). I propose that T^0 is not specified for present tense inflectional features, but that imperfective Asp^0 is specified as $[iINFL:IMPF]$. This imperfective inflectional feature Agrees directly with V^0 .³⁵

(47) Present Imperfective

ya-drusu
3M-IMPF.study

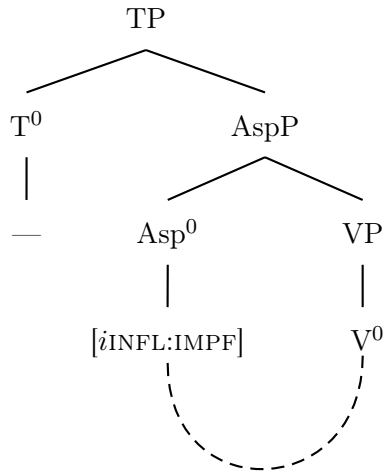

³⁵Benmamoun (2000) argues on several grounds that present tense is not specified across several varieties of Arabic. He observes that verbs are not required to combine with negation in the present tense in Egyptian Arabic (52), and that Standard Arabic allows an independent negative “auxiliary” only in the present (53). He also observes that the verb is able to remain comparatively low in present tense sentences, which he attributes to the failure of a specified T^0 to attract V^0 . A related point is that the present-tense copula in Arabic is null, while the past tense copula is a form of BE: this suggests that in clauses without a verbal predicate, there are no stranded inflectional features in the present tense.

In the past imperfective, by contrast, both T^0 and Asp^0 are specified for inflectional features. V^0 will be accessible for Agree with Asp^0 , but not with T^0 ; as a result, the the $[iNFL:PAST]$ features of T^0 will be stranded, as illustrated by the tree in (48):

(48) Past Imperfective

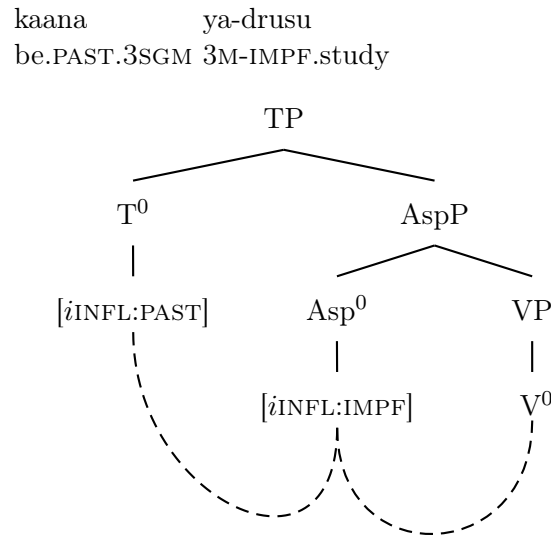

What the derivations described so far do not account for, however, is the occurrence of head movement in the inflectional domain. VSO word orders are widely available across varieties of Arabic, and are often attributed to verb movement to T^0 in the presence of a VP/*v*P-internal subject (Carnie and Guilfoyle, 2000, citing Mohammed 1988 and Fassi Fehri 1989).

In the (simple) past perfective, where I have proposed that Asp^0 is non-visible, head movement can occur based on the Agree relationship between T^0 and V^0 . This does not interact with further Agreement for inflectional features.

(49) Simple Past (final)

darasa
study.PAST.PFV.3SGM

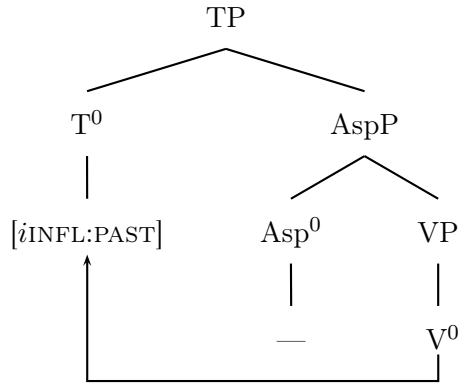

In the (default present) imperfective, shown in (47), T^0 has no visible features and therefore cannot attract V^0 via Agree. Moreover, the stranding of T^0 's [PAST] feature in (48) relies on V^0 *not* being attracted by Asp^0 ; consistency requires that Asp^0 not attract V^0 in the simple imperfective either. Deriving the occurrence of auxiliaries in Arabic thus requires that V^0 is lower in the simple imperfective than it is in the past.

There is independent evidence that the imperfective verb in Arabic occupies a low structural position. Benmamoun (1999, 2000) argues that the simple imperfective verb is lower than a past-inflected verb, citing its position relative to negation and low subjects.

Negation in Standard Arabic can be expressed either by an particle *laa* (which has a past allomorph *lam*), or by an inflected negative *laysa*. The particle *laa* occurs with verbal predicates only: it is compatible with the verb in (50a) and the copula in (50b), but not with the zero-copular present tense (50c):

- (50) a. *laa ya-lʔabu*
 NEG 3M-play
 “He does not play.” (Benmamoun, 2000, 53, 5a)
- b. *lam ya-kun muʔalliman*
 NEG.PAST 3M-be teacher
 “He was not a teacher.” (Benmamoun, 2000, 54, 7c)
- c. **laa muʔalliman*
 NEG teacher
 intended: “He is not a teacher.” (Benmamoun, 2000, 54, 7b)

The negative *laysa*, by contrast, occurs only with non-verbal predicates, *or* in the present imperfective. It is incompatible with the past tense (Benmamoun, 2000, 105, citing Fassi

Fehri 1993).

- (51) a. *laysa ya-lʕabu*
NEG.3SGM 3M-play
“He does not play.” (Benmamoun, 2000, 53, 5a)
- b. *laysa muʕalliman*
NEG.3SGM teacher
“He is not a teacher.” (Benmamoun, 2000, 53, 5b)
- (i) **laysa laʕiba*
NEG.3SGM play.PAST.PFV.3SGM
intended: “He did not play.” (Benmamoun, 2000, 53, 6)

Benmamoun proposes that these negative expressions are both associated with a Neg^0 head below T^0 , but that they differ in whether they combine with the verb via head movement. In support of this, he observes that *laysa* can be separated from the verb by an intervening subject, as in (52a), but that *laa* cannot be:

- (52) a. *laysa xaalid ya-ktubu š-šifr*
NEG.3SGM Khalid 3M-write the-poetry
“Khalid does not write poetry.”³⁶
- b. **lam ʔ-ʔullaab-u ya-ḏab-uu*
NEG.PAST the-students-NOM 3M-go-M.PL
intended: “the students didn’t go”³⁷

This suggests that the imperfective present verb, which is compatible with *laysa*, remains lower than Neg^0 , and is *not* required to move to T^0 .³⁸

The second piece of evidence for the low clausal position of the imperfective verb is its position with respect to the subject. Arabic languages are well known for allowing VSO word order. As mentioned above, this word order is widely attributed to a relatively high position for the verb (T^0) combined with a subject that remains low – within VP/*v*P (Carnie and Guilfoyle, 2000).

Interestingly, post-verbal subjects are reported to be required in some cases with past perfective verbs, but dispreferred with present imperfectives. Benmamoun provides the ex-

³⁶Benmamoun (2000, 102, 24b), citing Moutaouakil (1993, 85).

³⁷Benmamoun (2000, 97, 12a), citing Moutaouakil (1993).

³⁸Benmamoun discusses similar facts from Egyptian Arabic, where negation is *required* to occur as a verbal affix *ma-* in the past tense, but can occur as an independent particle *miš* in the present imperfective.

ample of idiomatic expressions, providing examples from Moroccan Arabic: in (53a), with perfective morphology on the verb, the idiomatic subject must be post-verbal, while in (53b), with imperfective morphology, the subject is pre-verbal.³⁹

- (53) a. baraka llahu fii-k
 bless.PAST.3SGM God in-you
 “May God bless you.”
- b. llah y-barik fii-k
 God 3M-bless.IMPF in-you
 “May God bless you.”
- (Benmamoun, 2000, 57, 18a-b)

More so than the negation facts discussed above, these facts suggest that the imperfective verb in Arabic is quite low in the clause, below even the base position of the subject. This supports the view that this verb remains below not only Neg^0 , but below Asp^0 as well, a conclusion that allows imperfective Asp^0 to block Agree between T^0 and V^0 in the past imperfective.

I have argued that head movement in the inflectional domain would have the potential to interact with the locality of Agree: if V^0 were to move to Asp^0 , it would be local to T^0 in the past imperfective, the specified [INFL:PAST] features of T^0 would not be stranded, and no auxiliary verb would occur. Consequently, the appearance of an auxiliary verb in the past imperfective requires that the verb remain structurally lower than Asp^0 . This converges with Benmamoun’s arguments that the imperfective verb is also structurally lower than the base position of the subject (i.e. within VP/vP).

This predicts that there will be languages in which the presence of head movement mitigates what would otherwise be a requirement for an auxiliary verb. I turn to this possibility in the next section: first clarifying this sections assumptions and proposals regarding head movement and verbal inflection, and then showing how head movement is centrally implicated in the inflectional system of Latin.

³⁹Benmamoun reports that the judgements extend to other languages, and that the same (non-absolute) preference for pre-verbal subjects in the present imperfective extends to colloquial speech in Moroccan Arabic. Sam Alxatib (p.c.) reports that the word order preference holds for the present imperfective in Palestinian Arabic also.

2.3.5 Head movement

In the discussions of English and Arabic, head movement has been *secondary* to Agree in the manipulation of verbal inflection. This is in contrast to many approaches, which assume that (in at least some languages) head movement (verb raising) is the central mechanism responsible for combining verbs with inflectional morphology.⁴⁰ I have nonetheless proposed that head movement is centrally involved in the verbal system, in that head movement can bring the verb into a local relationship with higher functional heads whose features would otherwise be stranded. In principle this would allow a verb to show more than one inflectional feature contrast (to be inflected for *both* tense and aspect, for example).

I propose, however, that head movement, like phrasal movement, is dependent on a pre-existing Agree relationship between two heads. This extends the role Chomsky (1998) assigns to Agree with respect to *phrasal* movement, particularly subject movement to Spec-TP and *Wh*-movement to Spec-CP. He proposes that when an Agree Probe has an “EPP” feature, the Goal is required to move to the specifier of the Probe’s head.⁴¹

If Agreement between some inflectional head Y^0 and V^0 is accompanied by head movement, the result will be that V^0 will be accessible to Agree with a yet higher inflectional head X^0 :

⁴⁰I discuss the incompatibility of movement-based analyses of verbal inflection with a non-selectional approach to auxiliary verbs in section 2.5.

⁴¹This is much in the spirit of Matushansky (2006), who argues for the identification of head movement and phrasal movement, though I depart from Matushansky in assuming that head movement does not necessarily follow from Agreement for the categorial/selectional features responsible for subcategorization. I also do not assume that head movement, like phrasal movement, is to the Spec of the *c*-commanding head, though it is possible that Matushansky’s formalism could be applied to the system developed here with few changes. The assumption that head movement follows upon featural Agree is also much in the spirit of Roberts (2010), though Roberts somewhat alters the traditional understanding of head movement.

The assumption that head movement is predicated on Agree is in fact contra Chomsky (1998), who proposes that head movement occurs post-syntactically on the branch to PF. Chomsky adopts this position on the grounds that head movement violates the Extension Condition and lacks semantic effects. Based on much subsequent work that has argued that head movement often *does* have semantic effects (Lechner, 2006; Matushansky, 2006; Hartman, 2010; Iatridou and Zeijlstra, 2010, among others), I adopt the view that head movement is, or at least can be, syntax-internal. If it is syntax-internal, we would expect that head movement would share with phrasal movement the requirement of being *triggered*.

(54)

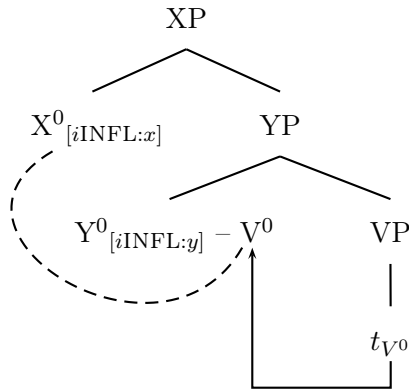

The fact that head movement occurs only as a consequence of Agree, however, has the consequence that head movement will never target a head without visible features, and may in fact skip over such heads (contra the Head Movement Constraint, Travis, 1984).

Now, something we know independently about the differences between languages is that they differ in the surface positions of their verbs. We attribute this to differences between languages in terms of where they allow or require head movement. For example, English lacks generalized verb movement to T^0 , but has T^0 -to- C^0 movement (in questions and other environments). French, by contrast, has both V^0 -to- T^0 and (more limited) T^0 -to- C^0 movement, while the mainland Scandinavian languages have obligatory verb movement to C^0 in main clauses (presumed to proceed via V^0 -to- T^0 movement due to the Head Movement Constraint), but clearly lack independent V^0 -to- T^0 movement in non-V2 clauses, where the verb remains to the *right* of negation and low adverbs.

Given these differences among languages, we know that languages themselves cannot be described as either having or lacking verb movement. Instead head movement is specific to the relationship between two heads. On the assumption that head movement, like phrasal movement, depends on the prior establishment of an Agree relation, we can also say that head movement depends on the relationship between particular *features* of heads.

I therefore assume that a language could have V^0 -to- T^0 movement, when T^0 and V^0 Agree directly (i.e. when all intervening heads lack visible features), but could at the same time *lack* V^0 -to- Voice^0 and Voice^0 -to- Asp^0 and V^0 -to- Asp^0 movement. This fine resolution for the presence or absence of verb movement in individual languages will form a crucial element of our account of particular auxiliary systems.⁴²

⁴²In the same way, the presence of head movement *throughout* the inflectional domain would prevent any

The absence of head movement between two specific functional heads – Voice⁰ and Asp⁰ – will be central to the account of Latin in the next section.

2.3.5.1 Illustration: Latin

The overflow pattern of Latin provides an example of a language in which head movement prevents features from being stranded in some environments, but the *absence* of head movement between two particular functional heads nonetheless gives rise to an overflow auxiliary BE.

Recall from (12), repeated in (55), that the relevant pattern in Latin involves the interaction of three heads: T⁰, Asp⁰, and Voice⁰. In the cases under discussion, Latin uses an auxiliary only in the combination of the perfect and the passive, as in (55c).

- (55)
- | | | |
|----|---|--------------------------|
| a. | Puellae crustulum consumpserunt. | <i>Perfect</i> |
| | girl-PL.NOM small.pastry-ACC eat-PL.PFV | |
| | “The girls ate the little pastry.” | |
| b. | Crustulum consumitur. | <i>Passive</i> |
| | small.pastry-NOM eat-PRES.PASS | |
| | “The little pastry is (being) eaten.” | |
| c. | Crustulum consumptum est. | <i>Perfect + Passive</i> |
| | small.pastry-NOM eat-PASS.PTCP be.3SG.PRES | |
| | “The little pastry was / has been eaten.” | |

I propose that in Latin, like English but unlike Arabic, both present and past values of T⁰ are specified,⁴³ and thus visible, and that *perfective*, rather than *imperfective*, is the specified value of Asp⁰. Uncontroversially, I assume that active values of Voice⁰ are unspecified.

In contrast to the other languages discussed so far, the main verb in Latin is marked for *two* specified inflectional categories in all of the cases in (55). If the verb were to remain *in situ*, this would be impossible: the lower of the inflectional functional heads in each case would block Agree between V⁰ and the higher inflectional head.

Head movement provides a means of overcoming this problem of locality. I propose that both Asp⁰ and Voice⁰ attract V⁰. In both the simple perfect and the simple passive, V⁰ Agrees with the closest c-commanding head, either Asp⁰ or Voice⁰. By assumption, this

inflectional features from being stranded, resulting in a highly agglutinative language.

⁴³Converging evidence for the fact that both present and past tense are specified is the fact that Latin has both present and past tense copular forms of BE, in contrast to a language such as Arabic where there is no verbal copula in the present tense.

Agreement is accompanied by head movement. As a result, V^0 is accessible to Agreement from T^0 , and no features are stranded.

- (56) a. **consumpserunt** (Perfect)
eat-PL.PFV

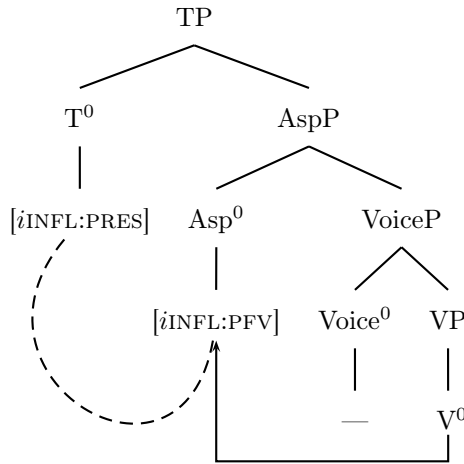

- b. **consumitur** (Passive)
eat-PRES.PASS

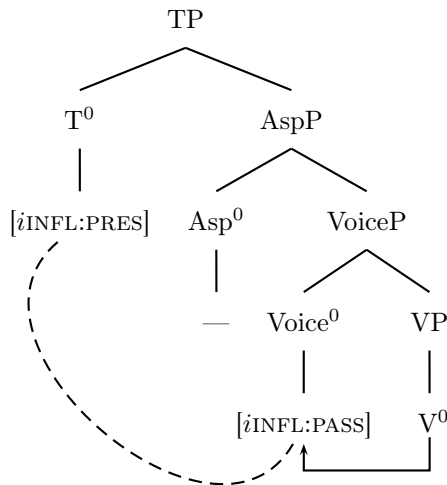

In the perfect passive, where *both* $Voice^0$ and Asp^0 contain syntactically visible features, their interaction becomes visible. This is the case in which the *absence* of head movement can give rise to an overflow pattern: I propose that there is *no* head movement between $Voice^0$ and Asp^0 .

In the relevant examples, V^0 will Agree with and (as in the simple passive) move to $Voice^0$. In this position it will be accessible to Agreement with one higher head: here this head will be Asp^0 . By assumption, however, no movement occurs between these two

positions. As a result, V^0 will remain in Voice^0 , where it is inaccessible for Agree with T^0 . The tense features of T^0 will thus be stranded, requiring realization with an auxiliary form of BE: *est*.

- (57) **consumptum est** (Perfect Passive)
 eat-PASS.PTCP **be.3SG.PRES**

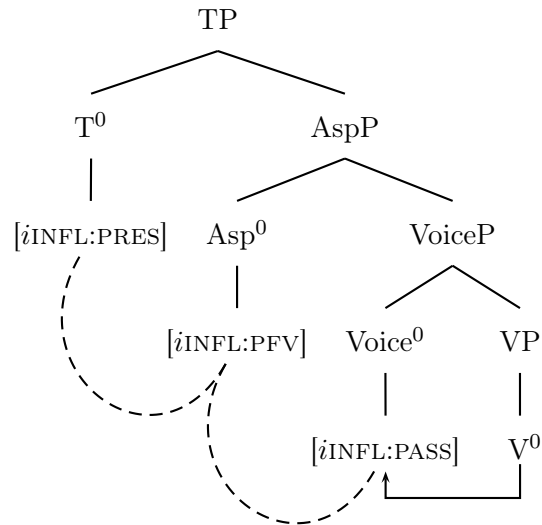

This proposal shares many features with the analysis of Latin presented by Embick (2000). Embick argues for Latin, as I argued more generally in section 2.2, that the appearance of an auxiliary in the perfect passive could not be the result of basic structural differences between the perfect active on the one hand, and the perfect passive on the other. One of his central arguments for this position is the fact that the auxiliary-based perfect passive in Latin does not arise only with clauses that are semantically and syntactically passive. The overflow auxiliary also appears in perfect forms of *deponents*, verbs that occur with passive morphology even in syntactically and semantically *active* contexts. An example is given in (58) using the deponent verb *hortor* ‘to exhort’ (forms drawn from Embick, 2000, 191):

- (58) a. hort-or
 exhort-‘PASS’
 ‘I exhort.’
 b. hort-ātus sum
 exhort-PASS.PTCP **be.1SG.PRES**
 ‘I (have) exhorted.’
 c. *hort-āvī
 exhort-SG.PFV

Embick argues against a selectional syntactic approach to auxiliary verbs – especially one in which the participial verb is viewed as a predicate adjective, and the auxiliary as a copula – on the grounds that deponent verbs are only *morphologically* passive. He proposes that deponents are verbs whose roots are merged with an arbitrary morphological [PASSIVE] feature. Embick argues convincingly that the fact that deponents trigger a periphrastic perfect passive means that their [PASSIVE] feature is syntactically visible; for him, this morphological feature, like a syntactic [PASSIVE] feature, prevents T^0 from attracting perfective Asp^0 .

In general outline, this is essentially the proposal advanced in this chapter regarding auxiliary BE cross linguistically. The primary difference is the assumed mechanism for stranding, which triggers the insertion of an auxiliary verb: Embick (2000) assumes that auxiliary BE occurs in the perfect passive because V^0 fails to *move* to T^0 , rather than being inaccessible to *feature transmission* (i.e. Agree) from T^0 .

The proposal that auxiliaries are triggered in Latin by the failure of verb movement to T^0 obviously cannot be generalized to languages, such as English, in which lexical verbs *never* move to T^0 . By allowing a uniform treatment of BE across different languages, the Agree-based approach to stranding proposed in this chapter is to be preferred.

Embick’s analysis also requires a somewhat baroque condition banning verb movement in precisely the perfect passive. He proposes that head movement between Asp^0 and T^0 is contingent on the *passive* features potentially contained within Asp^0 . Specifically, he proposed that T^0 fails to attract perfective⁴⁴ Asp^0 when Asp^0 also contains passive features.

This condition on head movement between Asp^0 and T^0 is highly stipulative. Though the analysis proposed here does not provide an *explanation* for the distribution of head movement, the condition is greatly simplified: there is *never* head movement between $Voice^0$ and Asp^0 on this account, and it is the presence of intervening visible features in Asp^0 that strands T^0 ’s features.

What Embick’s analysis does highlight is the need to incorporate deponent verbs into the analysis of Latin’s overflow auxiliary pattern. Because deponents are not syntactically

⁴⁴The reference to passive *features*, rather than a passive *head*, is necessary to account for the fact that deponents behave like passives as far as requiring an overflow auxiliary in the perfect.

Embick does not make use of unspecified, and therefore syntactically ignored, feature values. As a result, his analysis must further stipulate that imperfective Asp^0 *is* attracted by T^0 .

passive, we cannot attribute their morphology to a syntactically active head with passive features (for me, Voice^0), as Embick observes. Because Voice^0 is not the source of deponent passive features, it will not Agree with the verb, or trigger movement from V^0 to Voice^0 .

If Voice^0 is not syntactically specified in deponents, and it is the relationship between Voice^0 and Asp^0 that gives rise to an auxiliary in perfect passives, we might expect the derivation to proceed as it does in ordinary perfect actives: Asp^0 would Agree with the verb, triggering V^0 to Asp^0 movement, and this movement would bring the verb into a local relationship with T^0 , preventing the latter's features from being stranded.

Accounting for the presence of an auxiliary in deponent perfects within the analysis proposed so far thus requires abandoning either the view that Voice^0 is not syntactically specified in deponents, or that it is interaction of Voice^0 and Asp^0 , as heads, that gives rise to auxiliaries in the perfect passive. Embick argues convincingly that the prior option is not feasible: deponents are simply not syntactic passives, in any sense. This is the reason he proposes that it is the presence of passive *features*, rather than a passive *head*, that prevents perfective Asp^0 from moving to T^0 .

A similar move is possible in the Agree-based approach argued for here. Agree as defined is a relationship that holds directly between *features*, not between *heads*. It is reasonable to assume that head movement is therefore conditioned not directly by the label of the *head* on which the target is found, but instead by the *features* of the target. An *in situ* verb with [INFL:PASS] features would therefore look just like a verb sitting in Voice^0 with [INFL:PASS] features, as far as Agree-based head movement is concerned. If the two objects look the same for the purposes of head movement, they are expected to pattern together with respect to whether verb movement to Asp^0 occurs.

(59) **Deponent Perfect:**

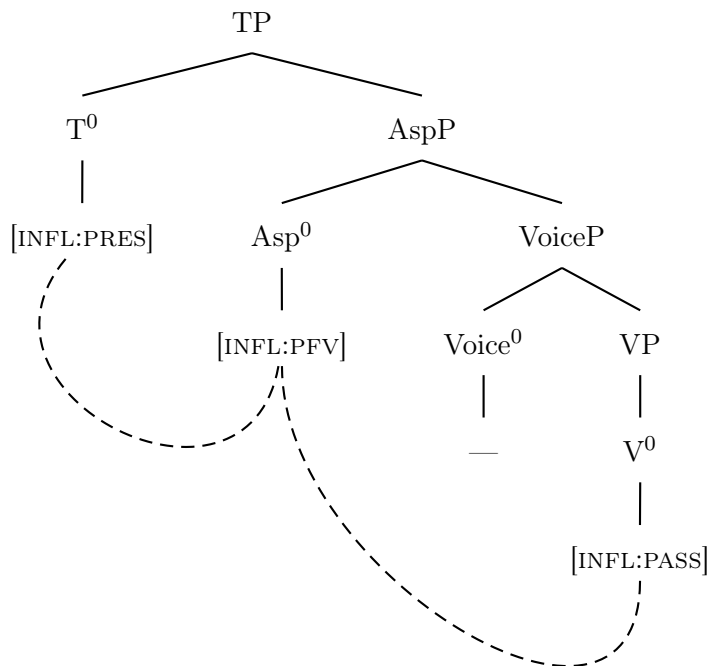

Just as in the non-deponent perfect, Asp^0 Agrees in (59) directly with the *in situ* verb. Because of the $[\text{INFL:PASS}]$ feature on V^0 , however, this Agree relationship is not accompanied by head movement: from the perspective of featural Agree the verb “looks like” it is located in Voice^0 , and Asp^0 does not attract Voice^0 .⁴⁵

To conclude, in Latin, as in Arabic, the absence of head movement between two positions (V^0 and Asp^0 in Arabic, Voice^0 and Asp^0 in Latin) gives rise to an overflow pattern of auxiliary use when it strands inflectional features of a higher functional head. Unlike in Arabic, however, the *presence* of head movement throughout the remainder of the inflectional domain in Latin allows the verb to Agree with more than one higher inflectional head.⁴⁶

Throughout the last several sections, it has been implicitly assumed that features that are syntactically stranded trigger the insertion of an auxiliary BE. The next section turns to the morphological mechanisms underlying this insertion.

⁴⁵Embick (2000) raises the issue of whether the deponent “passive” feature is a syntactic feature, or merely a morphological one: he concludes that as it influences a syntactic process (head movement) it must be a syntactic feature. A similar question arises in this context, with respect to the nature of the $[\text{INFL:PASS}]$ feature with which deponents are merged. It is clear that the feature is not interpretable, as deponents have neither the semantics of the passive nor any other unifying semantic property. This leaves two possibilities, as far as I am aware: either the feature is *uninterpretable*, in which case deponents provide evidence that uninterpretable features are not in fact fatal to a derivation in the absence of Agree, or the feature is a dedicated *morphological* feature, neither “interpretable” nor “uninterpretable”. If this latter possibility is correct, then we might imagine that all inflectional features are of this type; interpretability in the inflectional domain is a semantic property of *heads*, while features are simply the elements of morphological exponence.

⁴⁶Developments from Latin into the modern Romance languages are discussed in section 2.4.4.

2.3.6 The morphological realization of stranded features as auxiliaries

This section has so far been concerned with the syntactic underpinnings of verbal inflection. I have outlined an Agree-based approach in which certain inflectional features can *fail* to combine with a main verb, without basing that failure on the presence of intervening (syntactically specified) auxiliary verbs. The importance of this move is that it allows us to formulate a view of auxiliary verbs in which they are a response to, rather than the cause of, “high” inflectional morphology not being realized on the main verb.

The purpose of this section is to articulate more precisely why inflectional features that do not Agree with the main verb should be realized by a “default” auxiliary BE, rather than in some other manner. Simply stated, I propose that auxiliary BE satisfies a *morphological* requirement on the realization of inflectional features: though a structure is *syntactically* well-formed even if inflectional features are not located on the main verb, those stranded features cannot be spelled out unless they are provided with some verbal stem.

I assume the post-syntactic morphological framework of Distributed Morphology (DM: Halle and Marantz, 1993, 1994; Harley and Noyer, 1999; Noyer, 1997). At the core of DM is the proposal that lexical items – words and morphemes with phonological content – are not directly manipulated in the syntactic component. Instead syntactic derivations manipulate only abstract syntactic objects: lexical *roots* (associated with complex “encyclopedic” information), and formal morphosyntactic *features*.⁴⁷

A post-syntactic morphological component *interprets* the output of syntax. Two basic kinds of operations are available in this component: local modifications of the syntactic representation;⁴⁸ and the insertion of (underspecified) *vocabulary items* on the basis of the roots and features occurring together in particular positions, in a competition known as Vocabulary Insertion (VI). VI involves a series of disjunctively-ordered insertion rules in competition with one another; a position will be realized by a particular vocabulary item if the position’s features are a *superset* of the features included in the context of insertion for that vocabulary item.

⁴⁷The goal of this dissertation is not to argue specifically for a DM approach to morphology, but for the more general point that auxiliary BE occurs as a “last resort” to morphologically realize stranded inflectional features. In principle, this could be expressed in a lexicalist framework: such an account would resemble the account of DO-support proposed by Chomsky (1991), who argued that stranded features require the *syntactic* insertion of a “default” verbal head at a lower position in the clause. Criticisms that have been leveled against that account of DO-support would also apply to a similar account of auxiliary BE, however: for example, the last-resort insertion of an auxiliary verb would appear to violate the Extension Condition.

⁴⁸The morphological component may modify syntactic representations by Impoverishment, Merger, Fusion,

As an example, (60) shows a set of VI rules that would generate the inflectional morphology of (regular) English verbs.

- (60) a. /-s/ ↔ [uINFL:PRES],[3SG]
 b. /-ing/ ↔ [uINFL:PROG]
 c. /-d/ ↔ [uINFL:PAST]
 d. /-en/ ↔ [uINFL:PERF]
 e. /-en/ ↔ [uINFL:PASS]⁴⁹
 f. -∅ ↔ *elsewhere*

It is (semantically) uninterpretable instances of features that condition VI in (60). This reflects the directionality of Agree proposed in section 2.3.1, together with the condition that inflectional features are pronounced in the *lowest* position in a sequence of positions related by Agree. This was stated as a principle in (37), repeated in (61):

(61) *Morphological realization of inflectional features*

In a sequence of inflectional features [F₁], [F₂], . . . , [F_n] are related by Agree, such that each feature [F_i] c-commands [F_{i+1}], it is the last feature in the sequence (the structurally lowest) that is morphologically realized.

This principle importantly assumes that the morphological requirement that results in auxiliary verbs is a property of the target of Agree, rather than the original source of the features. In other words, auxiliary insertion occurs in response to a deficiency of the target, rather than the source. Support for this view, at least regarding English, comes from the position of non-finite auxiliaries relative to mid-clausal elements such as adverbs and floated quantifiers. These elements occur uniformly higher than passive *be*, but optionally lower

or Fission. Impoverishment is an operation that deletes certain features from the representation, generally in the context of other features. Impoverishment was first proposed as a mechanism by Bonet (1991), and is also extensively discussed in Noyer (1997). Morphological merger, discussed most extensively by Embick and Noyer (2001), is essentially the morphological counterpart of syntactic Lowering or Affix Hopping: it adjoins a head to the head of its complement, under conditions of (structural) adjacency. Fusion takes two terminal nodes within a single head and combines them into one node (position of exponence); Fission is the reverse of this, splitting a single node into two positions of morphological exponence.

The morphological component may also be modified after Vocabulary Insertion by so-called *readjustment rules* Halle (1990); Halle and Marantz (1993), which are responsible for morphophonological allomorphy of root morphemes.

⁴⁹It is possible that English verbal inflection would be more perspicuously accounted for by merging [INFL:PERF] and [INFL:PASS] into a single feature [INFL:PTCP]. I leave this issue to one side here, as it will not affect the details of the general morphological mechanism of BE-insertion.

than progressive *be*.

(62) and (63) illustrate this contrast with respect to sentence-level adverbs Jackendoff (1972). As seen for the adverb *fortunately* in (62), such adverbs must occur to the left of passive *be*, indicating that they occur in a structurally higher position. In contrast, (63) illustrates that the same adverb can occur to the *right* of progressive *be*, suggesting that this instance of *be* is located higher in the clause than its passive counterpart.⁵⁰

- (62) a. The cake has (fortunately) been (*fortunately) eaten.
b. The cake will (fortunately) be (*fortunately) eaten.
c. The cake seemed to (fortunately) be (*fortunately) eaten.
- (63) a. The children have (fortunately) been (?fortunately) eating the cake.
b. The children will (fortunately) be (?fortunately) eating the cake.
c. The children seemed to (fortunately) be (?fortunately) eating the cake.

The same contrast can be detected in the possible positions of floated quantifiers, which cannot occur below a certain level in the clause (Kitagawa, 1986; Sportiche, 1988, et seq.). As (64) shows, such floated quantifiers cannot occur to the right of passive *be*, but can occur to the right of progressive *be*, once again suggesting that progressive *be* is located in a higher structural position.

- (64) a. The cakes have (all) been (*all) eaten.
b. The children have (all) been (?all) eating the cake.

In all of these cases, however, the structural *origin* of the features realized by passive and progressive *be* is parallel. This suggests that *be* is merged not in the position from which stranded features *originate*, but in the position to which they are *assigned*; i.e. the position in which they are uninterpretable.⁵¹

Having discussed the position in which inflectional features are realized, let us now turn more directly to the mechanics of how stranded inflectional features might trigger BE-insertion. It is characteristic of all the vocabulary items in (60) – and of inflectional morphology generally – that they are specified as *affixes*, unable to occur as independent

⁵⁰A similar point is made by Dechaine (1993, 334-7).

⁵¹Of course, if head movement occurs, these two positions will be linearly indistinguishable, because interpretable and uninterpretable instances of a feature will be contained in a single head.

words, though at least *-ing* would be *phonologically* capable of being an English word. When inflectional features occur in the same position as a lexical verb, the affixal status of these vocabulary items is not problematic, because the categorized lexical verb (which I will notate as V^0) is itself realized as a verb stem.

Throughout this chapter I have argued that there are instances of inflectional features that do *not* occur on lexical verbs, and that these are realized by the default auxiliary BE. The question now is now the insertion of BE is triggered, if a head contains only inflectional features.

I propose that inflectional features require the presence of a V^0 constituent in order to be morphologically well formed.⁵² This follows Halle and Marantz (1993), who assume that all English inflectional affixes realize an independent head Tns, which “requires a V to make a well-formed [Morphological Structure] word” (137). If this well-formedness condition is not met, an empty V node “without any features other than its category identification” is inserted into the structure.⁵³

This does not entirely resolve the question of *how* the insertion of an empty verbal node is triggered. The Agree-based model of verbal inflection pursued in this chapter assigns inflectional features directly to V^0 or to a higher functional head. This contrasts with Halle and Marantz’s assumption, just mentioned, that all inflectional features in a language like English are generated as an independent head Tns, which combines with a verb by either lowering or raising.⁵⁴

If inflectional features occur directly on a head, but trigger their own set of VI rules, they must undergo a form of *fission* from their host, in order to be spelled out as independent

⁵¹DM generally assumes that lexical roots are acategorial, and that categorization is accomplished by means of categories such as little-*v*, little-*n*, little-*a*, etc. Whether a verbal categorizing head should be identified with a head v^0 that introduces the external argument of a verb, or a head v^0 that determines the eventiveness of a predicate, is not entirely clear, and remains a topic of open research. I remain agnostic on this issue, and will continue to use the category label V^0 to refer to an already-categorized element.

⁵²The requirement that inflectional features be realized on V^0 is what motivates the insertion of BE. If this morphological condition were not active in a language, “stranded” inflectional features would pose neither a syntactic nor a morphological problem, and no auxiliary would be inserted. I would suggest that this is the case for the systems of inflectional *particles* found in some languages, for example the languages of the Kwa family in West Africa (Aboh, 2009).

⁵³Halle and Marantz make this proposal not in the context of auxiliary verbs, which they do not discuss at all, but in the context of a (fairly traditional) analysis of DO-support. They therefore propose that this empty V node is realized by default as the verb *do*. In chapter 4, however, I argue against a last-resort insertion analysis of DO of the kind advanced by Halle and Marantz, on the grounds that it encounters serious problems when applied to DO-support phenomena outside English.

⁵⁴It is not clear what the source of this Tns head is in the case of participial features, but Halle and Marantz leave the issue of auxiliary verbs entirely aside, focusing the interaction of tense features with the verb.

vocabulary items. Broadly speaking, fission in DM is the process that allows more than one vocabulary item to be inserted to realize a single syntactic position.

For Halle and Marantz (1993) fission literally ‘splits’ a morphosyntactic terminal into two terminals, as in (65). Each of the resulting terminals X and Y will be the locus of Vocabulary insertion, resulting in two Vocabulary items being inserted where only one would have been otherwise.⁵⁵

$$(65) \quad [X \ \alpha + \beta] \longrightarrow [X \ \alpha] + [Y \ \beta]$$

When inflectional features occur directly on V^0 , exactly this kind of fissioning must take place, creating a new node that is the locus of insertion for inflectional affixes:

$$(66) \quad [V \ uINFL:\alpha] \longrightarrow V^0 + [Infl \ uINFL:\alpha]$$

In cases where the verb has undergone head movement, inflectional features may already be instantiated on a separate head, and fission will not be necessary. This would potentially be the case for tense features located on an Asp^0 head to which V^0 had moved:

$$(67) \quad V^0 + [Asp \ uINFL:PAST]$$

In (67), the $[uINFL:PAST]$ feature on Asp^0 does not need to undergo fission, because it is already on a head that is the sister of a V^0 . Any inflectional features on V^0 itself, however, would have to undergo fission as in (66).

The question is what happens a head such as Asp^0 in (67) occurs *without* a sister head V^0 . What we want is that an empty V^0 position is created as a sister to the inflectional features of Asp^0 , which will then be realized by the least-marked verb BE. Following Halle and Marantz, we could propose that there is a repair strategy that *inserts* such an empty V^0 in the relevant structural configurations.

It is not necessary to propose this kind of independent insertion operation, however. Instead we can make use of the *fission* operation, which already provides a constrained mechanism for insertion. Consider the rule in (66). As stated, it is a rule that fissions

⁵⁵For Noyer (1997), by contrast, fission is a more abstract process, whereby multiple VI rules can apply to a single position of exponence, so long as that position has features that have not been “discharged” by a VI rule. The notion of “feature discharging” requires that vocabulary items *primarily* express some features, and *secondarily* express others; Features are discharged by Vocabulary items that primarily express them.

inflectional features from a node of category V^0 . We could understand it instead, however, as a rule that fissions verbal lexical information (V^0) from a head with inflectional features. Understood through such a lens, the rule can be generalized to take any terminal node with inflectional features and output a V^0 node with a sister Infl node containing those inflectional features:

$$(68) \quad [X \ u\text{INFL}:\alpha] \longrightarrow V^0 + [\text{Infl} \ u\text{INFL}:\alpha]$$

where there is no V^0 already sister of X^0 .

If X^0 is of category V^0 , (68) will operate exactly as (66) did. If X^0 is of some other category, however, a V^0 node will be inserted (or X^0 will be re-categorised).⁵⁶ By assumption, a contentless V^0 will be realized as BE, which is the *default* or *elsewhere* verb.

This section has proposed a morphological mechanism that inserts an auxiliary BE in response to the presence of “stranded” inflectional features – features that are not syntactically associated with a verb. The crucial property of this account is that BE is not inserted due to deficiencies of the *syntactic* representation, but instead in response to morphological requirements of the affixes inserted on the basis of inflectional features.

2.3.7 Summary

Early in this chapter, we saw that auxiliary patterns fall into two basic types: the additive pattern, exemplified by languages like English, where auxiliary verbs always occur in certain inflectional environments; and the overflow pattern, exemplified by languages like Kinande and Latin, where auxiliary verbs arise only when certain inflectional categories are *combined*.

I argued that the overflow pattern demonstrates that auxiliary verbs are a response to structural *complexity* in the inflectional domain. The best analysis of the overflow pattern, and the one that allows *unification* with the additive pattern, is one in which auxiliaries realize *stranded* inflectional material, inflection that was unable to combine with a main verb in the course of the derivation.

This approach to auxiliary verb constructions called for a model of verbal inflection with three basic components: the uncontroversial view that inflectional information is associated with a *separate* position from the lexical verb – i.e. with dedicated functional positions such as T^0 and Asp^0 ; the possibility that inflectional material may *fail* to combine with a verb;

⁵⁶Another alternative might be to merge a node V^0 to X .

and a morphological mechanism for realizing these stranded features with a default verb – i.e. BE.

This resulted in a system with certain formal similarities to Chomsky’s (1957) Affix Hopping account of the English inflectional system, and its subsequent developments. In the Affix Hopping system, inflectional material in the form of discrete affixes move *downward* in the tree; if this movement does not unite them with a verb (including syntactically-represented auxiliary verbs), a default verb is supplied via *Do*-support.

Here I have maintained the view that inflectional material is assigned *downward* in the syntax, though as *features* rather than distinct affixes, and I have proposed that BE auxiliaries, not *Do*-support, are the default realization of stranded inflectional material.

The idea that inflectional information is transmitted *downward* is a key departure from much current work in syntactic theory. Since at least Chomsky (1998), it has been widely assumed that feature values can be communicated only *up* the tree, given a definition of Agree in which unvalued and uninterpretable Probes, upon merger, search their complement for a valued counterpart Goal.

The definition of Agree adopted here, repeated from (23) in (69), departs from Chomsky’s formulation by allowing Agree relationships in which a *valued* feature c-commands the *unvalued* feature to which it contributes its value. As observed above, this joins an increasing body of work that argues for exactly this kind of *downward* transmission of featural information via Agree (Baker, 2008; Haegeman and Lohndal, 2010; Zeijlstra, 2010; Merchant, 2011; Wurmbrand, 2011).

(69) *Agree*

Agree is a relationship between two features such that an unvalued feature [F:_] receives the value of a feature [F:val] of the same type iff:

- a. A head α containing [F:_] is c-commanded by a head β containing [F:val].
- b. There is no head γ containing a matching feature [F:(val)], such that γ c-commands α and β c-commands γ .

Though framed in terms of Agree, this mechanism is also intended to maintain the *locality* of an Affix Hopping style transformation. It is relativized minimality that enforces the restriction that two heads cannot Agree for inflectional features across an intervening

head that is *also* specified for verbal inflectional features, as in (69b):⁵⁷

The tree in (70), repeated from (29) schematizes the “downward” transmission of features via the Agree operation adopted here:

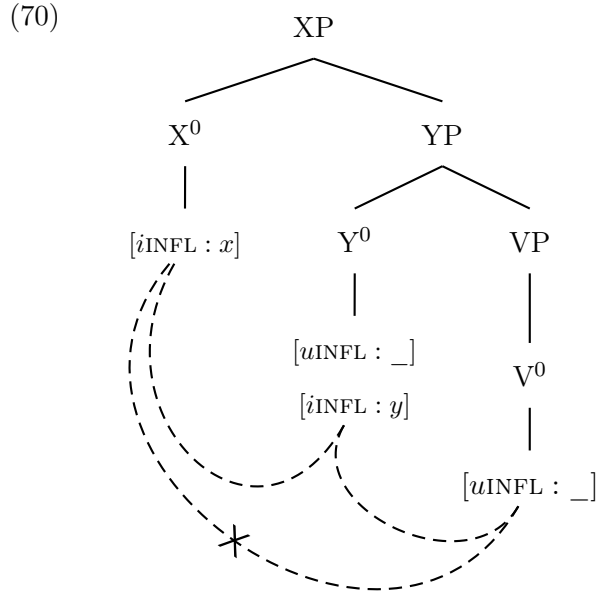

The enforced locality of Agree is what makes it possible for inflectional features to fail to combine with the main verb: in (70), for example, the $[i\text{INFL}:x]$ feature of X^0 is forced by relativized minimality to Agree with the unvalued inflectional feature of Y^0 , and cannot directly Agree with any features of V^0 . As a result, the feature on X^0 is *stranded*.

I then showed that the locality of Agree can appear to be circumvented in one of two ways, creating the illusion that inflectional information ought to have been stranded but was not. First, if the intervening head Y^0 in a structure such as (70) is *not* specified for inflectional features, the head will not be visible for Agree and will thus be “skippable”, as in (71), repeated from (32). I argued that non-specified functional heads should be associated with *default* feature values, linking this to the literature on featureal and morphological unmarkedness.

⁵⁷This requires the assumption that inflectional features are merely different values of a single feature *type* (Adger, 2003).

(71)

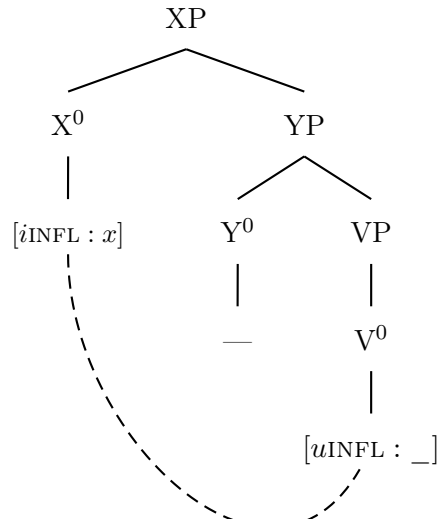

Second, *head movement* may bring the verb into the domain of Agreement from higher inflectional heads. I proposed that head movement, like phrasal movement, is dependent on a pre-existing Agree relationship, and that languages vary in which head-to-head Agree relationships are accompanied by movement. This extends already-assumed variation among languages – whether they instantiate V⁰-to- T⁰ or T⁰-to- C⁰, for example – into a more finely detailed inflectional domain: the question is not only whether V⁰ moves to T⁰ (which it may do directly when no intervening functional heads have specified inflectional features), but whether V⁰ moves to Voice⁰ or Asp⁰ when *those* heads are specified for inflectional features. This was illustrated by the tree in (54), repeated in (72):

(72)

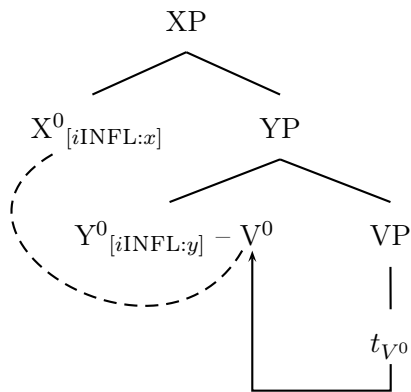

In both of these structures, features that occur on a head that does not immediately dominate VP are nonetheless able to Agree with a head that contains a V⁰.

Finally, we come to the third component of this approach to verbal inflection: a morphological mechanism for realizing stranded features via a default auxiliary verb. I formulated

this mechanism within the framework of DM.

I have proposed that features are stranded when they are morphologically interpreted in a position that does not contain V^0 , if the features' own morphological realization requires an adjacent verb. In all the cases we are concerned with here, this is the position to which they have been assigned, not the one in which they originated: that is, it is the originally unvalued features that are morphologically spelled out.

I proposed that a generalized process of fission creates a $V^0 + \text{INFL}$ sequence from any head that contains either inflectional features or a categorized verb root. In the absence of any content for this V^0 (canonically the presence of a lexical root) it is spelled out by an *elsewhere* verb: this least-marked verb, a verb with no properties other than its categorial specification, is BE.

Taken together, this provides a system of verbal inflection in which variation among auxiliary patterns results from two separate factors: the instances of head movement a language instantiates, and the features that a language identifies as default, and hence unspecified/non-visible. I have argued that its main components – downward assignment of inflectional features, the possibility that such assignment may fail, and the morphological repair via auxiliary BE– are necessary to account for the overflow pattern, and hence required for a unified approach to the additive pattern.

2.4 Further Illustration

This section further illustrates the system developed in section 2.3, looking at auxiliary patterns in a number of further languages. What we will see is that the specific patterns of auxiliary use will in every case be able to be accounted for by two parameters of variation: which feature values a language chooses to mark (i.e., which feature values are visible to Agree), and where (if anywhere) head movement accompanies Agreement between two heads.

The section begins with a discussion of the languages introduced in section 2.1 that have not already been discussed in section 2.3: Kinande, Basque, and Finnish. Kinande, discussed immediately below, is interesting because its overflow pattern is essentially the same as Arabic's, but involves many more possible contrasts in both tense and aspect. In section 2.4.2, the additive pattern of Basque is shown to be one in which auxiliaries are uniformly required to host tense information when *either* perfective or imperfective aspect,

but a small set of verbs that allow simple tensed forms (with no auxiliary) illustrate the effect of the default (unspecified) aspect. Finnish, discussed in section 2.4.3, is simpler still, with additive auxiliary BE occurring in the perfect, but Finnish presents an interesting case of a dedicated *negative* auxiliary.

Section 2.4.4 turns to the modern Romance languages, illustrating how relatively minor changes to the inflectional system found in Latin could give rise to quite different patterns of auxiliary use. The focus is on the additive pattern of modern French and the partially overflow pattern of modern Romanian.

2.4.1 Kinande

Kinande presents a simple first illustration of how Agree and feature visibility can interact to produce an overflow pattern of auxiliary use. First of all, recall the pattern of auxiliary use found in Kinande, repeated in (73) from (9)–(11). Past tense forms, with default perfective interpretation, involve a simple inflected verb, as do aspectual forms in the default present tense. This is illustrated in (73a-b) for the recent past and the progressive.

When both past tense and aspect are expressed at once, however, tense is expressed on an auxiliary while aspectual marking appears on the main verb, as we see in (73c):

- (73) a. tw-**á**-húma *Recent Past*
 1PL-PAST-hit
 ‘We hit (recently, not today)’
- b. tu-**nému**-húma *Progressive*
 1PL-PROG-hit
 ‘We are hitting’
- c. tw-**á**-**bya** i-tu-**nému**-húma *Recent Past + Progressive*
 1PL-PAST-**be** LNK-1PL-PROG-hit
 ‘We were (recently, not today) hitting.’

Articulated in syntactic terms, this pattern involves the interaction of Asp^0 and T^0 . To account for the inflectional patterns illustrated in (73), it will be necessary to assume that V^0 moves to neither of these positions, but remains in some lower projection.⁵⁸ Head movement will thus play no role in the pattern of auxiliary use in Kinande.

⁵⁸This follows much previous work on Bantu syntax, which argues that verbs move (approximately) to a mid-clausal position at the edge of an expanded *vP* domain but below inflectional projections. This accounts for the fact that verbs in Kinande, as in other Bantu languages, can be inflected for a large number of derivational or argument-structural categories, including applicative, causative, reciprocal, and

What will play a role is the non-visibility of certain inflectional *values* of Asp⁰ and T⁰. We have seen that many values of both of these heads can be morphologically marked in Kinande. What are never marked are *present* tense and *perfective* aspect; the latter is furthermore the default interpretation of all past forms. This situation is common throughout Bantu languages (Nurse, 2008).

(74) *Non-specified feature values in Kinande*

- a. present is an unmarked (non-specified) value of T⁰
- b. perfective is an unmarked (non-specified) value of Asp⁰

Because these values are not specified as features in the syntax, present T⁰ and perfective Asp⁰ will be *non-visible* for the purposes of Agree.

On the assumption that present T⁰ and perfective Asp⁰ have no specified features, both (74a) and (74b) will involve only a single active inflectional head, which will Agree with V⁰ in both cases, leaving no stranded features.

- (75) a. **tu-nému-húma** (Progressive) b. **tw-á-húma** (Recent Past)
 1PL-PROG-hit 1PL-PAST-hit

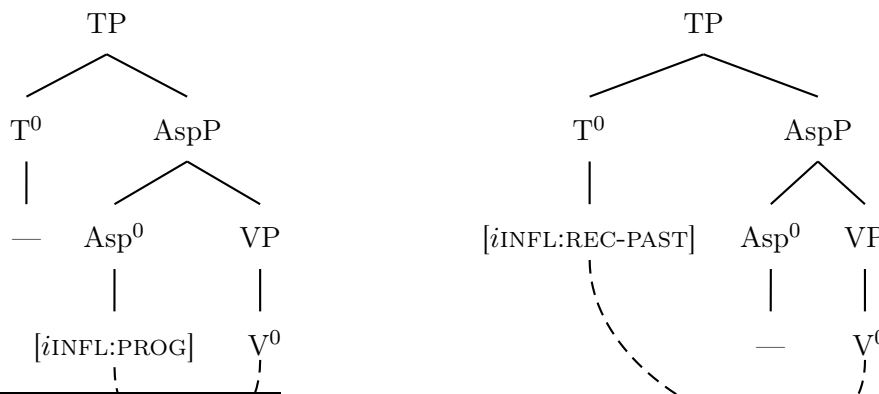

passive ‘extension’ suffixes. They also can stack a small number of non-temporal prefixes, including an iterative reduplicative prefix and a (possibly cliticized) object marker. This is illustrated in (i) (note that the causative marker *-is-y-* is discontinuous):

- (i) eri-ba-huka=huk-is-er-an-y-a
 INF-OBJ.3PL-RED=carry--CAUS-APPL-RECIP--CAUS-a
 “to make them carry for one another over and over”

Following work such as Baker (1985), I assume that this sequence of inflection is able to be built up because the verb moves through a series of (low) functional projections. Verbs in Kinande may thus move to Appl⁰ and Voice⁰ projections, among others, without moving to Asp⁰ or T⁰. Trees in this section vastly simplify this clausal structure by representing the verb as occurring *in situ* within the VP, for the sake of expository simplicity.

In the past progressive, by contrast, both T^0 and Asp^0 will have visible features. Asp^0 will Agree with V^0 , but (by assumption) V^0 will not move to Asp^0 . When T^0 Probes, the closest c-commanded potential Goal will be Asp^0 , and so locality will prevent it from continuing to search for and Agree with V^0 :

- (76) **tw-á-bya i-tu-nému-húma** (Past Progressive)
 1PL-PAST-BE LNK-1PL-PROG-hit

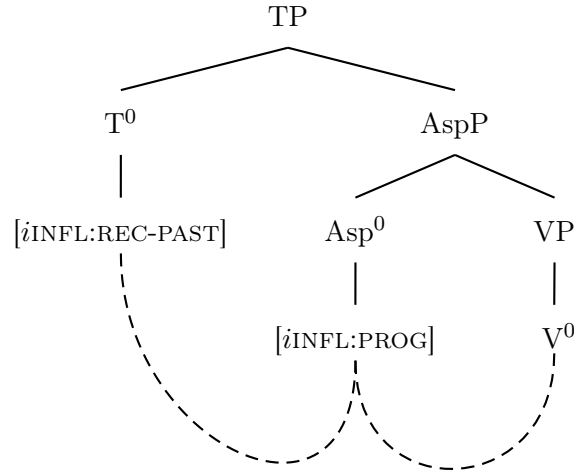

The features of T^0 in (76) are stranded, because they have not established an Agree relation with V^0 ; at the point of morphological realization, they will therefore be realized on an auxiliary.

The overflow pattern of auxiliary use arises in this case because each of two interacting heads has only *one* syntactically specified value. If Kinande had visible present tense features, an additive pattern would result.

2.4.2 Basque

Recall from (7), repeated in (77), that Basque obligatorily uses auxiliaries for any combination of tense and aspect:

- (77) a. Jon-ek liburu irakurr-i **dau.**
 Jon-ERG book read-PFV AUX.PRES
 “Jon has read the book.”
- b. Jon asarra-tzen **sa-n.**
 Jon get.angry-IMPF AUX-PAST
 “Jon used to get angry.”

Basque represents a simpler instantiation of an additive pattern of auxiliary use than English, with interactions arising only between T^0 and Asp^0 , parallel to Kinande and Arabic. The different pattern of auxiliary use arises, however, from Basque *lacking* unspecified values for either T^0 or Asp^0 (whereas both Kinande and Arabic had unspecified present tense and perfective aspect values).

The analysis of this pattern will posit that Basque, like Kinande, involves no head movement and only two interacting heads.

Take the present perfective in (77a) as an example. As illustrated by the tree in (78), Asp^0 Agrees with V^0 , but V^0 remains *in situ*. T^0 subsequently Agrees with Asp^0 , and is unable to Agree directly with V^0 . As a result, the tense features of T^0 are stranded, and must be realized by an auxiliary whose form is determined, following Arregi (2004), by the agreement inflection it also realizes, whose presence is orthogonal to our discussion here:

- (78) **irakurri dau.** (Present Perfective)
 read-PFV AUX.PRES

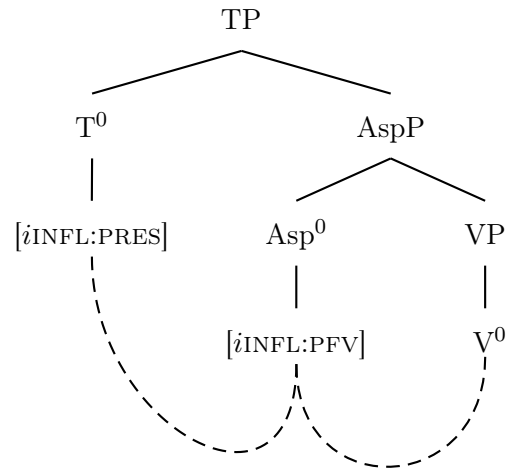

The additive pattern in Basque – specifically, the fact that *all* tensed clauses discussed so far require an auxiliary verb, is a consequence of the fact that both T^0 and Asp^0 are specified for inflectional features. If there were a version of either of these heads with a truly default/unmarked value, and thus no specified inflectional features, no features would be stranded, and we would not predict the occurrence of an auxiliary verb.

I argue that the “synthetic” verbs of Basque represent exactly such a case, in which a totally default Asp^0 lacks inflectional features, and consequently the features of T^0 are able to Agree directly with the main verb.

In addition to the auxiliary pattern represented in (77), Basque also has a small set of “synthetic” verbs that *do* possess simple present and past tense forms (alongside the periphrastic aspectual forms accounted for already). This set of verbs varies between dialects; representative examples occur in (79):

- (79) a. Jon-ek ingles-a daki.
 Jon-ERGEnglish-ABS.SGknows.PRES
 “Jon knows English.” (Arregi, 2000, 20a)
- b. Au tren-a aringainge ru.)
 this train-ABS.SGfast go.PRES
 “This train goes fast (i.e. is able to go fast).” (Arregi, 2000, 21a)

Arregi (2000) observes that these simple tense forms correspond to *non-habitual imperfective* meanings. The periphrastic imperfective, involving an auxiliary, is required to express habitual meanings for these synthetic verbs:

- (80) a. Jon-ek erantzun-ak jaki-txen dau.
 Jon-ERGanswer-ABS.PLknow-IMPFAUX.PRES
 “Jon usually knows the answers.” (Arregi, 2000, 20b))
- b. Au tren-a aringainge ju-ten da.
 this train-ABS.SGfast go-IMPFAUX.PRES
 “This train goes fast (i.e. generally/habitually goes fast).” (Arregi, 2000, 21b))

For non-synthetic verbs, which lack simple tensed forms, the periphrastic imperfective is systematically ambiguous between habitual and non-habitual interpretations. Arregi notes furthermore that periphrastic imperfective forms ordinarily have futurate interpretations, as in (81):

- (81) Athletic-ak bixar jolas-ten dau. (=24) in Arregi 2000)
 Athletic-ERGtomorrow play-IMPFAUX.PRES
 “The Athletic is playing tomorrow.”

Verbs with simple tensed forms, by contrast, have futurate interpretations *only* in their non-auxiliary uses; periphrastic forms lack the futurate interpretation:

- (82) a. Jon Bilbo-a ru bixar. (=23a) in Arregi 2000)
 Jon Bilbao-ALLATIVE goes tomorrow
 “Jon is going to Bilbao tomorrow.”

- b. *Jon Bilbo-a ju-ten da bixar. (= (23b) in
 Jon Bilbao-ALLATIVE go-IMPFAUX.PREStomorrow
 Arregi 2000)

The non-habitual, non-progressive imperfective of the simple tensed forms of synthetic verbs represent a *default* imperfective interpretation. Arregi argues that they represent the totally default aspectual value in Basque, and that what sets synthetic verbs apart is that they lack an Asp^0 projection altogether.

Arregi's analysis of auxiliaries in Basque resembles Embick's (2000) proposals regarding Latin: both assume that auxiliaries result from the failure of V^0 to move all the way to T^0 . Having claimed that Asp^0 is *absent* in the simple tenses, Arregi proposes that V^0 is no longer prevented from composing with T^0 , and so that no auxiliary is required to support the stranded T^0 .

The framework I have adopted here follows much semantic work in assuming that a head such as Asp^0 is always projected in clauses with an aspectual interpretation: though the simple tensed synthetic forms have *default* aspectual interpretations, this is not the same as having *no* aspectual interpretation. Arregi's proposal can be adapted to this framework, however: rather than saying that the synthetic verbs are lexically distinguished by being able to select T^0 directly, rather than having to select Asp^0 , we can say that this small set of verbs in Basque is lexically distinguished by being able to select an instance of Asp^0 that is default in the sense of not being specified for inflectional features.

Because this Asp^0 does not carry any inflectional features, it will not intervene for the purposes of Agree between T^0 and V^0 :

(83) Synthetic Simple Present

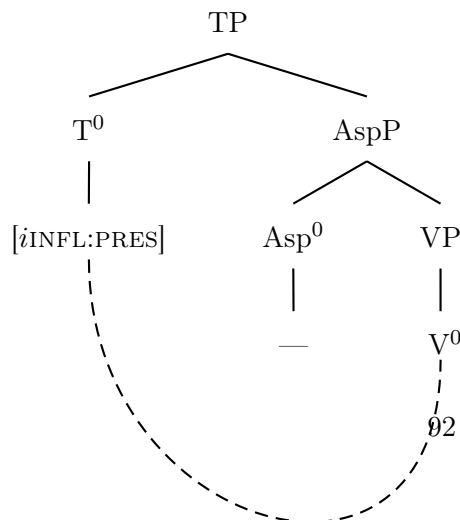

The features of T^0 will consequently not be stranded, and no auxiliary will be inserted by the morphological component.

In conclusion, the synthetic verbs of Basque illustrate a case in which a truly default value for an inflectional head results in the *absence* of an auxiliary verb, supporting the position argued for in this chapter, that auxiliaries occur as a result of structural and featural complexity in the inflectional domain.⁵⁹

2.4.3 Finnish

Finnish was introduced in section 2.1.1 as an example of the additive pattern. As (84), repeated from (8), shows, Finnish uses the auxiliary *olla* ‘to be’ to form the perfect, just as many familiar Indo-European languages do.

- (84) a. Lapset **ovat** syö-neet kakku.
 The.children be.PRES.3PL eat-PTCP.PLthe.cake
 “The children have eaten the cake.”
- b. Lapset **olivat** syö-neet kakku.
 The.children be.PAST.3PL eat-PTCP.PLthe.cake
 “The children had eaten the cake.”

This pattern can be accounted for if Finnish, like English but unlike Basque, has visible feature specifications for all values of T^0 , but only for perfect values of Asp^0 . A further assumption is required that V^0 does not move to Asp^0 when Asp^0 is specified.

- (85) **ovat** **syö-neet** (Present Perfect)
 be.PRES.3PL eat-PTCP.PL

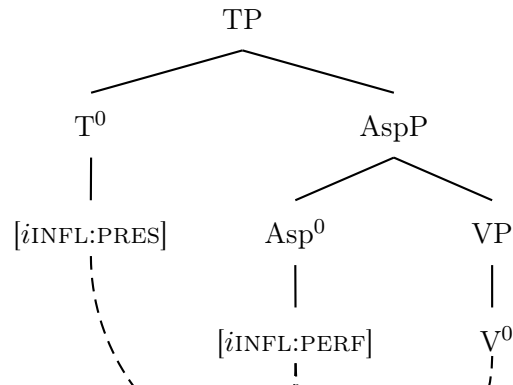

⁵⁹Much the same pattern of auxiliary use can be found in Hindi, where both imperfective and perfective marking on the main verb require the presence of an auxiliary to host tense information. As in Basque, however, Hindi allows “aspectless” verbs to bear tense inflection directly, removing the need for an auxiliary verb. Unlike Basque, however, this option is available to all verbs in Hindi.

Nothing further is necessary to account for the auxiliary pattern of the Finnish perfect.

A different facet of Finnish auxiliary use is interesting in the current context, however, which is the use of a dedicated negative auxiliary *ei* to express clausal negation, exemplified in (86). This verb has a defective paradigm, expressing agreement inflection but having only present-tense forms. The periphrastic perfect just discussed is used to express negative anterior meanings, with auxiliary *olla* occurring in a participial form below negative *ei* (Sulkala and Karjalainen, 1992, 115).⁶⁰

- (86) a. **En** tule kotiin
NEG-1SG come home-ILL
“I won’t come home(illative).”
- b. Lapset **eivät** ole-et syö-neet kakkua
The.children NEG.3PL be-PTCP.PL eat-PTCP.PL
“The children haven’t eaten the cake.”

A question that arises is whether clausal negation in Finnish is fundamentally structurally or categorically different from clausal negation in languages without a dedicated negative auxiliary. It need not be, of course: the negative auxiliary *ei* can be a head of Neg^0 that happens to be morphologically a verb. If the negative head in Estonian is specified for inflectional features, it will *intervene* for purposes of Agree between T^0 and V^0 , as in (87).⁶¹

- (87) Simple Negative (= (87a))

⁶⁰A main verb following *ei* occurs in a special negative form, according to Sulkala and Karjalainen (1992, 115). This special negative form historically had a final [k], which apparently triggers phonetic lengthening of the following phoneme in spoken Finnish. The form of a main verb following *ei* is described as the weak grade of the inflectional stem by Karlsson (1999, 70).

⁶¹I have identified the inflectional feature of Neg^0 as [INFL:NEG]; given its morphological exponence, it may instead be a more general [INFL:PTCP] feature, but this is not directly relevant to the discussion here.

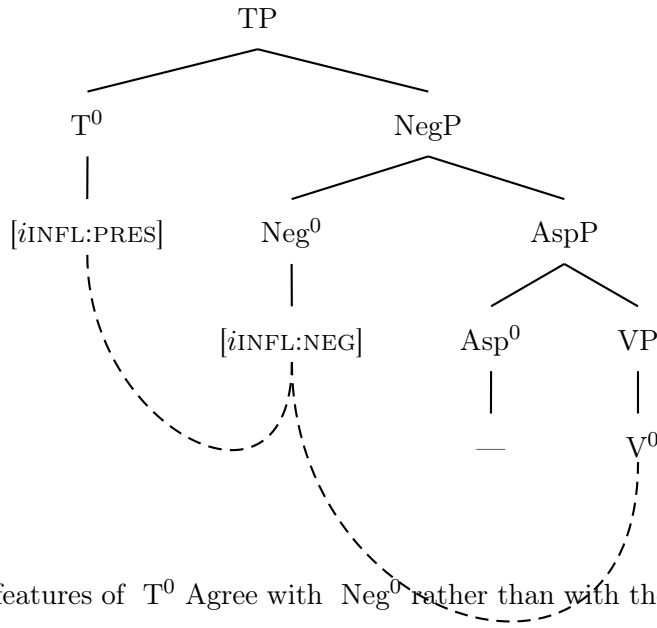

The features of T^0 Agree with Neg^0 rather than with the lexical verb. I would propose that these features are stranded, but that their presence on the negative head triggers the insertion of a *more specified* auxiliary than the totally-default auxiliary *olla*.⁶² The negative auxiliary in Finnish is then the first case discussed in this dissertation in which the presence of features other than those that are morphologically stranded triggers the insertion of a less default auxiliary than BE. This account extends in principle to all auxiliary verbs; chapter 3 develops this into an account of auxiliary HAVE.

2.4.4 Developments from Latin: French and Romanian

In contrast to the overflow pattern of Latin, discussed above in section 2.3.5.1, for the most part the modern Romance languages exhibit straightforwardly additive patterns of auxiliary use. Discussing the additive pattern of French, I show that the French system of auxiliary use can be described as a minimal modification of Latin's, identical but for the absence of two instances of head movement in the inflectional domain.

I then turn to an interesting issue in the use of auxiliaries in the Romanian perfect. Romanian has developed a periphrastic (auxiliary-based) form for the simple perfect, but *not* for the pluperfect. This appears to contradict section 2.3, which predicts that auxiliaries occur always in *more* featurally or structurally complex contexts: on all reasonable assumptions regarding feature specification in Romanian, the pluperfect is *more* featurally complex

⁶²The Standard Arabic markers of negation *laa* and *laysa* discussed in section 2.3.4.2 can be considered in a similar light, as an indication that negative features are treated as part of the language's inflectional feature system.

than the perfect, and yet only the latter allows an auxiliary. I argue that this apparent contradiction can be resolved once we consider the broader context of Romanian inflectional morphology, in which a contrast between realis and irrealis forms is centrally implicated.

2.4.4.1 French

This section aims to demonstrate that the auxiliary patterns of modern Romance languages – exemplified here by French – can be accounted for by only very minor modifications to the system proposed for Latin in section 2.3.5.1.

Where Latin had simple verbal forms for both the perfect and the passive (though not the perfect passive), the modern Romance languages have developed additive auxiliary patterns for these categories.⁶³ The basic interaction between the passive and the perfect can be illustrated with reference to French. The basic indicative paradigm we are concerned with is illustrated in (88). For the purposes of the comparison with Latin, I set aside the fact that the perfect auxiliary in French alternates between HAVE (*avoir*) and BE (*être*); chapter 3 discusses the relationship between HAVE and BE in the perfect at much greater length.⁶⁴

- (88) a. Je lis le livre
 I read.PRES the book
 ‘I read/am reading the book’ (present imperfective)
- b. Je liris le livre
 I read.1SG.IMPF.PAST the book
 ‘I was reading/used to read the book’ (past imperfective)
- c. J’ai lu le livre
 I-HAVE.1SG.PRES read.PTCP the book
 ‘I read/have read the book’ (past perfect(ive))
- d. Le livre est lu (par les enfants)
 the book BE.3SG.PRES read.PTCP (by the children)
 ‘The book is (being) read (by the children)’ (present imperfective passive)
- e. Le livre était lu
 the book BE.3SG.IMPF.PAST read.PTCP
 ‘The book was (being) read.’ (past imperfective passive)

⁶³This is true not only of French, but also Spanish, Italian, Portuguese, and (for the passive and the present perfect) Romanian.

⁶⁴All of the modern Romance languages have developed HAVE auxiliaries in at least a subpart of the perfect paradigms under discussion here. In chapter 3 I argue that HAVE results from the presence of additional syntactic information in a position that would otherwise be realized by the totally-default auxiliary BE (following Freeze 1992 and Kayne 1993).

- f. Le livre a été lu
 the book HAVE.3SG.PRES BE.PTCP read.PTCP
 ‘The book was read.’ (past perfective passive)

The relevant points of interest are that the passive auxiliary (*être*) occurs in all passive forms (88d-f), and the past perfective (*passé composé*) auxiliary (either *avoir* or *être*) occurs in all non-imperfective past forms (88c,f). Both auxiliaries co-occur in the perfective passive, in (88f). This contrasts with the pattern seen in Latin, where a (single) auxiliary occurs only in the counterpart of (88f).

Section 2.3.5.1 argued that the overflow perfect passive auxiliary in Latin arises due to the fact that the main verb generally moves to intermediate inflectional projections (i.e. Asp^0 and Voice^0), and thus can Agree with more than one inflectional head, but that the system crucially *lacks* movement between Voice^0 and Asp^0 themselves.

The additive pattern in French can be accounted for by a minimally different system, which simply *lacks* some of the instances of head movement available in Latin: specifically, the verb in French will generally remain *in situ*, moving only when Agreeing directly with T^0 . Movement to T^0 is assumed in order to account for the position of tensed verbs in French discussed in Emonds (1978), Pollock (1989), and much subsequent work.

As in Latin, the inflectional heads of relevance are T^0 , Asp^0 , and Voice^0 . Also as in Latin, perfective Asp^0 and passive Voice^0 will have specified feature values ([*i*INFL:PFV] and [*i*INFL:PASS], respectively), while imperfective Asp^0 and active Voice^0 will be featurally non-specified and therefore non-visible to Agree.⁶⁵

In the imperfective active, where no auxiliaries occur, T^0 will therefore be the only head with visible inflectional features. T^0 will thus be able to Agree directly with V^0 , and this Agree relation will be accompanied by head movement:

- (89) Je lis/lirais le livre
 I read.1SG.PRES/IMPF.PAST the book

⁶⁵I assume that the overt past imperfective affixes that occur in (88) are in fact *default* morphology, rather than the expression of particular syntactic values.

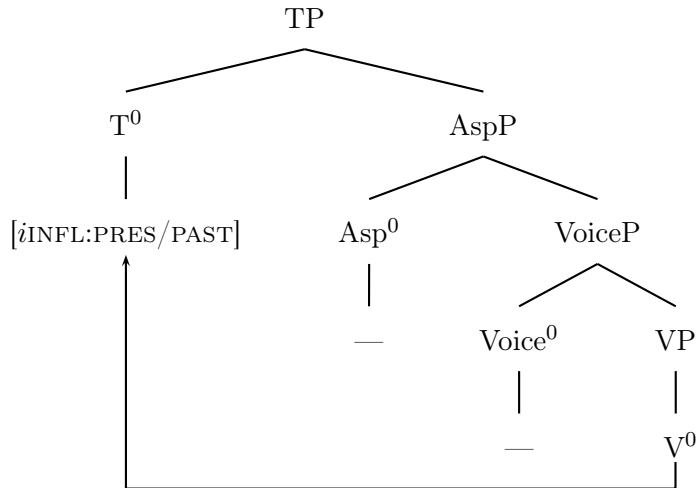

T⁰ will also attract Asp⁰ and Voice⁰ on the basis of Agree, accounting for the high position of finite perfective and passive auxiliaries. In short, Agreement between T⁰ and any other head in the inflectional domain will be accompanied by head movement.

As in English, however, neither Asp⁰ nor Voice⁰ themselves will attract the main verb on the basis of Agree. This gives rise to auxiliaries whenever one of these heads contains visible features, because such features block T⁰ from being able to Agree directly with V⁰. This is illustrated in (90) for a past passive: Voice⁰ Agrees with V⁰ but remains *in situ*. T⁰ is able to Agree with Voice⁰ across Asp⁰, because Asp⁰ contains no visible features, but T⁰ is not able to Agree with V⁰. Voice⁰ moves to T⁰, where the stranded [INFL:PAST] features trigger realization as *était* (the imperfective morphology being the default form).

- (90) Le livre **était** lu
 The book BE.PAST read.PTCP (past passive)

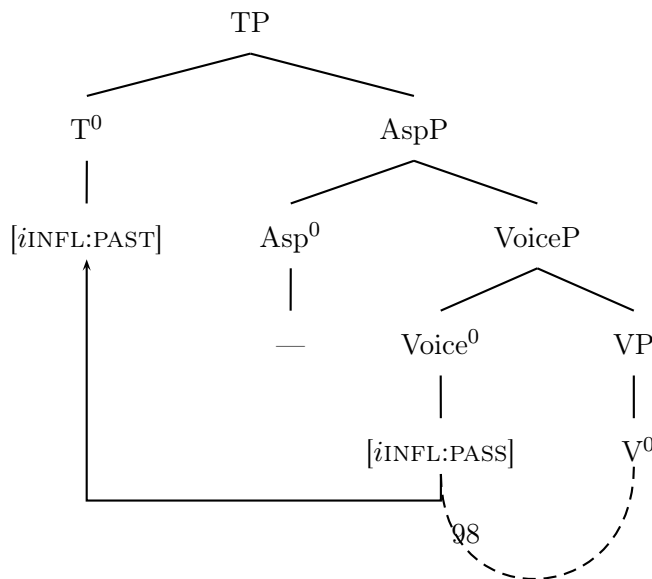

The perfective structure in (91) is generated in a precisely parallel fashion, except that it is perfective Asp⁰ that is visible, and active Voice⁰ that remains unspecified and thus non-visible:

- (91) J'ai lu le livre
 I-HAVE.PRES read.PTCP the book (perfective)

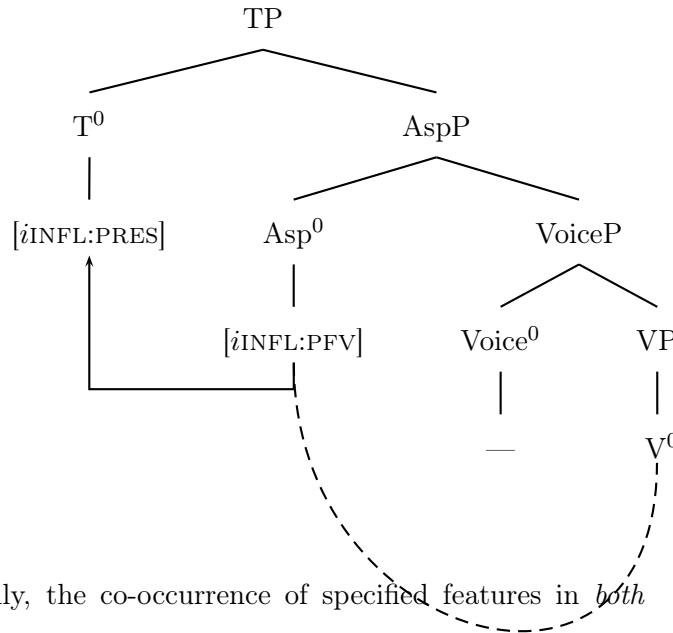

Finally, the co-occurrence of specified features in *both* Asp⁰ and Voice⁰, as in the perfective passive, gives rise to *two* auxiliaries, exactly as in English. Here the absence of movement from V⁰ to Voice⁰ is accompanied by the absence of movement from Voice⁰ to Asp⁰ (which was the one instance of head movement missing in the Latin inflectional system):

- (92) Le livre a été lu
 The book HAVE.PRES BE.PTCP read.PTCP (perfective passive)

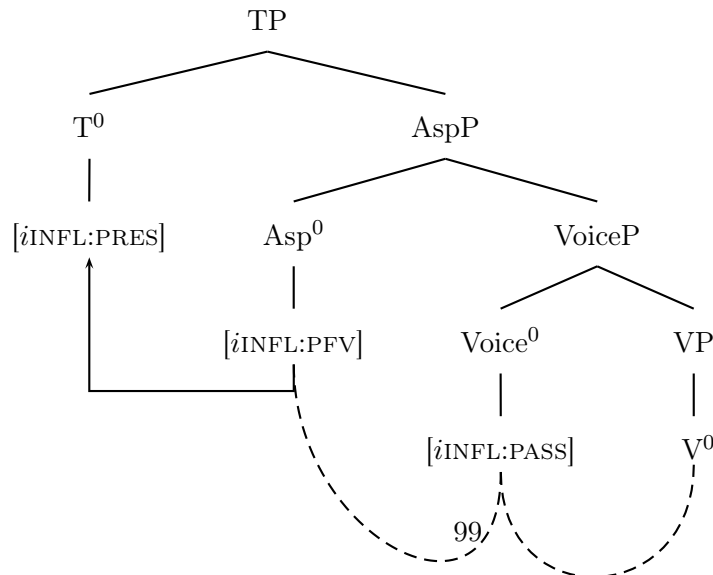

It is of interest to note that archaic and literary forms of French use the synthetic *passé simple* in place of the periphrastic *passé composé* discussed above.

This suggests that earlier stages of French retained the V^0 -to- Asp^0 movement posited for Latin, when Asp^0 contained syntactically active [INFL:PFV] features.

In conclusion, note that the French system of auxiliary verbs, which on the surface looks remarkably different from the prior system of Latin, is in fact only minimally different from it: the differences amount, on this account, entirely to the *loss* of two instances of head movement that did exist in Latin: V^0 -to- $Voice^0$ and V^0 -to- Asp^0 . Because $Voice^0$ and Asp^0 continued to be associated (via Agree) with higher inflectional heads which assign overt morphological content, the fact that they do not attract V^0 results in those higher inflectional features being *stranded*.

2.4.4.2 Romanian

In contrast to some other modern Romance languages, Romanian has retained the simple perfect paradigm of Latin until relatively recently. Examples of this perfect form, which also has past perfective interpretations, appear in (93):

- (93) a. **Perfect:**
 eu citii
 I read-PERF.1SG
 “I read / have read.”
- b. **Pluperfect:**
 eu citisem
 I read-PLUPF.1SG
 “I had read.”

Contemporary Romanian increasingly replaces the simple perfect of (93a) with an auxiliary form, the compound perfect of (94a), in which tense is realized on a form of the auxiliary BE (*a fi*), which is followed by a participial form of the main verb. What is striking about this development in Romanian, however, is that the pluperfect does *not* allow a parallel compound form (Donca Steriade, p.c.):

- (94) a. **Compound Perfect:**
 eu am citit
 I have.1SG.PRES read.PTCP

“I have read.”

b. ***Compound Pluperfect:**

*eu aveam citit
I have.1SG.PST read.PTCP

The impossibility of (94b) is unexpected. On a selectional account of auxiliaries it would be particularly puzzling: if the perfect in Romanian were to select an auxiliary HAVE, we would expect that the ability to say *I **have** read* would automatically lead to the compositional availability of *I **had** read*.

The framework for inflection and auxiliary verbs developed in this chapter does not immediately render it less puzzling. To allow for an auxiliary in the perfect, but not in the pluperfect, it must be the case that present tense features of T^0 are stranded in the perfect, but past tense features of T^0 are never stranded in the pluperfect. Because the clause structure *below* T^0 would be identical in both cases (consisting of Asp^0 bearing perfect features and a lower lexical verb), the difference would have to be in the specification of present and past features of T^0 : we would have to say that past tense is *not* specified for inflectional features, while present tense is. This, however, reverses the universal markedness relationship between present and past tense (of which, to my knowledge, present is *always* the unmarked member), and there is no corroborating evidence internal to Romanian that would support this conclusion.

I would like to suggest that a solution is available if we consider the possible stranding of *higher* inflectional features. The verbal system of Romanian is notable for the central role of the contrast between *realis* and *irrealis* verbal forms: it has a wide range of non-indicative forms, generally marked by auxiliaries, and the contrast between *realis* and *irrealis* is responsible for an alternation between HAVE and BE as the perfect auxiliary (Avram and Hill, 2007).

What is unusual about this distinction in Romanian, however, is that the indicative forms appear to be comparatively *marked*: among languages with a HAVE/BE alternation conditioned by the *irrealis* status of the clause, Romanian is alone in using BE in *irrealis* contexts and HAVE in *realis* contexts (Avram and Hill, 2007; McFadden, 2007). Further to this, the form of BE that occurs in *irrealis* contexts does not inflect for either tense or person and number; instead it is an invariable form *fi*.

On the basis of this, I would suggest that the stranded features that give rise to an auxiliary in the perfect in Romanian are not the features of T^0 , but instead the features of a head $Mood^0$, the locus of the indicative/subjunctive contrast located between C^0 and T^0 (following Rivero, 1994, Zanuttini, 1997, Han, 2000, among many others).

Any inflectional features in $Mood^0$ – which I label here as $[INFL:INDIC]$ – will be stranded in the absence of verb movement to T^0 . The occurrence of an auxiliary in the compound perfect would thus reflect the *failure* of present tense T^0 to attract the verb in Asp^0 :

(95) Compound perfect: *am citit*

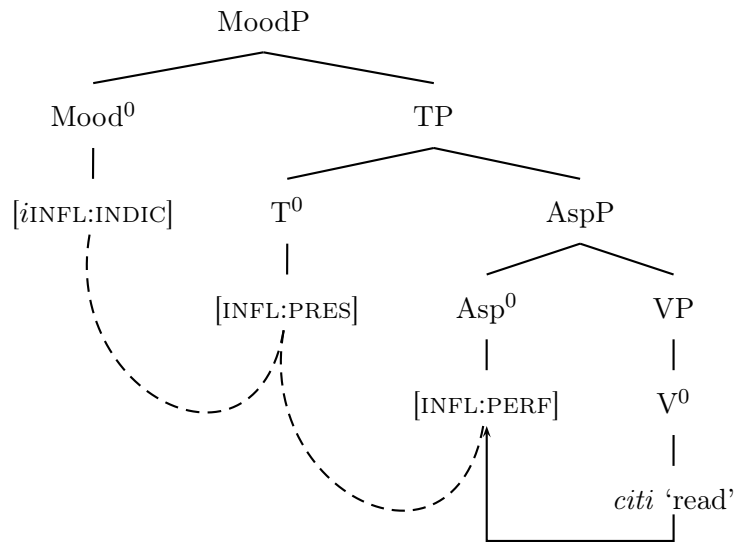

The absence of an auxiliary in the pluperfect can be accounted for by proposing that past T^0 , by contrast, *always* attracts Asp^0 . Because the verb is as high as T^0 , it is directly accessible for Agree with $Mood^0$, and no features are stranded:

(96) Pluperfect: *citisem*

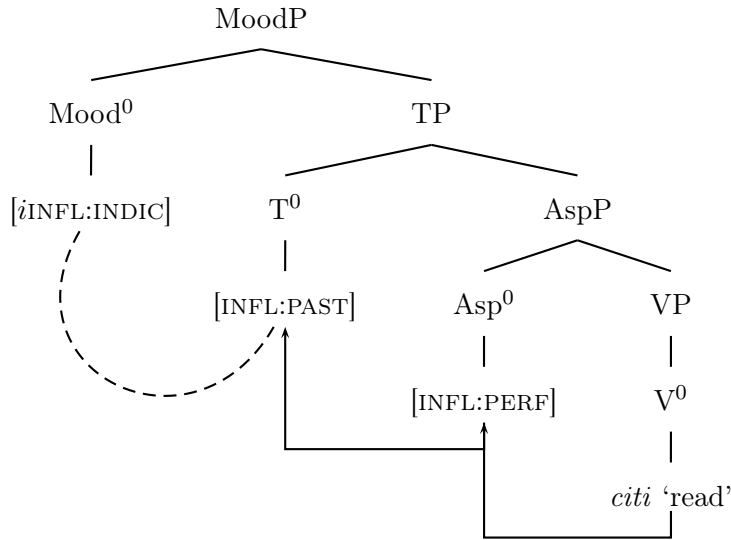

The interest of this proposed analysis of Romanian is that it rests not only on the strandability of features higher than T^0 , but also on the parameterization of head movement not only to the identity of the target of Agree, but also the features of the attracting head itself.

2.5 Implications of downward feature valuation

Section 2.3.1 proposed a form of Agree whose directionality is the reverse of that argued for by Chomsky (1998). This reverse Agree allows inflectional feature values to be transferred downward in a syntactic structure (for example from an inflectional functional head such as Asp^0 onto the main verb). I have argued that the facts of verbal inflection and of auxiliary patterns requires this downward transmission of inflectional information, for both conceptual and empirical reasons.

This formulation of Agree nonetheless raises a number of issues, particularly once we consider domains in which Chomsky's original formulation of Agree has been widely applied. This section begins by further justifying the modified form of Agree proposed in section 2.3.1, by showing that other classic operations proposed in the domain of verbal inflection (Raising and Lowering) encounter empirical and conceptual problems in structures with more than one verb and in auxiliary constructions. After that review, I turn to the problems the reverse definition of Agree raises, particularly with regards to one of the original motivations for Chomsky's definition of Agree, morphological agreement with post-verbal subjects.

2.5.1 Against Lowering and Raising

At the beginning of section 2.3 I argued that a system of verbal inflection that could account for the overflow pattern of auxiliary use required that inflectional information be introduced in a position independent of V^0 , from which position it could *fail* to combine with the verb. I observed that this dovetails with the semantic approaches in which inflectional interpretations are associated with a sequence of dedicated functional heads.

It is also in accord with two approaches to verbal inflection that pre-date Agree: Raising, i.e. head movement (Emonds, 1978; Pollock, 1989; Chomsky, 1993), and Lowering (Chomsky, 1957; Jaeggli and Hyams, 1993; Bobaljik, 1995; Embick and Noyer, 2001). These are schematized in (97), contrasted with Agree.

(97) Three major approaches to verbal inflection

a. Lowering

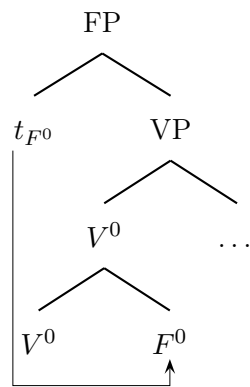

b. Raising

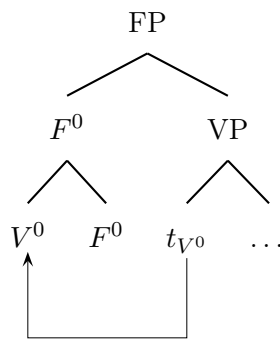

c. Agree

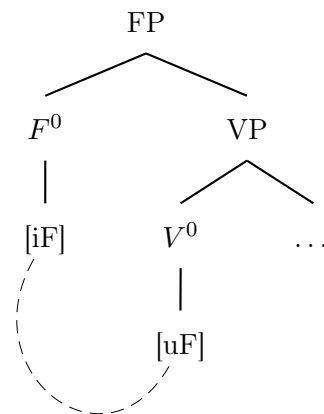

Classic Lowering and Raising approaches to inflection assume that inflectional affixes are literally generated as the heads of their associated functional projections, and that they compose with V^0 by movement. Because of this, neither can provide a cross-linguistically unified theory of verbal inflection; indeed, the syntactic literature has often assumed a great deal of cross-linguistic variation in the domain of verbal inflection.

The diversity of analyses of verbal inflection can be seen by comparing English and French. While inflection in English has often been argued to result from a *Lowering* operation, largely to explain the low position of the verb together with the phenomenon of DO-support, verbal inflection in French is often taken to result from head-movement or Agree followed by head movement. Because these languages use different mechanisms to

compose inflection with the main verb, the analysis proposes, their verbs end up in different surface positions.

English and French, however, have similar patterns of auxiliary use: both show additive patterns for auxiliaries in both the passive and the perfect.⁶⁶

- (98) a. *English: additive auxiliaries in passive and perfect*
- (i) The cake was eaten.
 - (ii) The children have eaten the cake.
 - (iii) The cake has been eaten.
- b. *French: additive auxiliaries in passive and perfect*
- (i) Le gâteau était mangé.
 - (ii) Les enfants ont mangé le gâteau.
 - (iii) Le gâteau a été mangé.

If verb position reflected the syntax of inflection, and the syntax of inflection determined auxiliary patterns, we would not expect to see such surface similarities between French and English. The fact we do argues in favour of developing a different, more cross-linguistically uniform, approach to verbal inflection.

The view that auxiliaries result from the failure of inflection to combine with the main verb, however, is not itself incompatible with the possibility that different languages use different mechanisms to combine verbs with higher inflectional information. However, the fact that both Raising and Lowering assume that inflection corresponds to functional heads, and combine with the verb via movement of some kind, raises a number of problems.

The first problem is the existence of clauses in which two verbs surface with the same inflectional content. Serial verb constructions in some languages provide an example of this, as the following examples cited in (Aikhenvald and Dixon, 2007) demonstrate:

- (99) a. Koṇḍa (Steever, 1988, 71–73)
- | | |
|------------------------|---------------------|
| vā-n-a | sū-n-ap |
| come-NONPAST-1PL.exc | see-NONPAST-1PL.exc |
| ‘We will come and see’ | |
- b. Lango (Noonan, 1992, 211–12)

⁶⁶The issue of HAVE in the English perfect and alternation between *avoir* ‘have’ and *être* ‘be’ in the French perfect is set aside for the purposes of this comparison, but will be taken up again in the discussion of auxiliary selection in chapter 3.

ácwé áló rwót
 1sg-fat-HAB 1sg-exceed-HAB king
 ‘I am fatter than the king’ (lit. I-fat I-exceed king)

c. Saramaccan (Byrne, 1990, 152)

a (bi) féfi dí wósu (bi) kabá
 he TENSE paint the house TENSE finish
 ‘He had painted the house already.’

In all of these cases the same inflectional morphology occurs on two verbs in a series. If that morphology originates as a functional head, and combines with the verb via movement (of itself or of the verb), we face the mystery of how the functional head is *doubled* in the process. By contrast, if inflectional information consists of abstract features, manipulated by Agree, the presence of the same inflection in multiple positions can be understood as an instance of Multiple Agree.⁶⁷

Another example of this is the *go get* construction (Zwicky, 1969; Shopen, 1971; Carden and Pesetsky, 1977), in which the verbs *go* or *come* can be immediately followed by another verb (*They’ll come see us tomorrow.*, *She can go hang for all I care!*). As Shopen (1971), Carden and Pesetsky (1977), and Pullum (1990) variously show, the English *go get* construction requires both verbs to appear in the *same* zero-inflected form. In other languages this requirement of inflectional identity is clearer, because the *go get* construction occurs in environments with non-zero inflection:

(100) Modern Greek

- a. **ela** **htipise** ti bala
 come.IMP.SG kick.IMP.SG the ball
 ‘Come kick the ball.’
- b. **pigene** **stasu** eki grigora
 go.IMP.SG stand.IMP.SG there quickly
 ‘Go stand there quickly.’

(101) Modern Hebrew

⁶⁷Takano (2004) argues that the appearance of the same inflection on two coordinated verbs in English provides a similar argument in favour of an Agree-based approach to (English) inflection. He argues that any movement analysis of inflection would predict that inflection would occur in only *one* of two conjuncts – as is in fact the case in Japanese. The interaction of movement and coordination is notoriously complex, however: ATB extraction involves the movement of two elements (at least on traditional analyses), but they are pronounced as one outside the site of coordination. We might imagine that a reverse of this process could “split” an inflectional head that Lowers onto the verb.

- a. **lex kra / tikra** efer
go.IMP.M read.IMP.M/ read.2SG.FUT.M book
'Go read the book.'
- b. **ševi šti** kafe iti
sit.IMP-F drink.IMP-F coffee with.me
'Sit [and] drink coffee with me.'

(102) Marsalese (Cardinaletti and Giusti, 2001)

- a. **Vaju a pigghiu** u pani.
go1SG to fetch1SG the bread
'I go and fetch the bread.'⁶⁸
- b. A **petra vene** a **ruzzulla** assutta.
the stone come3SG to roll3SG here
'The stone comes rolling down here.'

As I argue in Bjorkman (to appear), the examples from the *go get* construction are incompatible with the view that inflection corresponds to syntactic heads, and combines with the verb via movement.

In addition to these general challenges for Raising and Lowering approaches to verbal inflection, there are additional problems specific to auxiliary verb constructions.

I have argued that, regardless of the mechanism that combines inflection and the verb, auxiliary BE occurs as a repair, in response to stranded inflection. Once we arrive at the view that that auxiliary BE is not syntactically represented, problems arise for both Raising and Lowering in clauses that would have multiple auxiliary verbs.

Consider Lowering first: if Lowering involves actual syntactic displacement of a head, then once an affix Lowers, there is no longer any position for higher affixes to Lower to in turn. In the English progressive passive, for example, once Voice⁰ lowers onto V⁰, there would be no position for Asp⁰ to lower onto in turn:

(103)

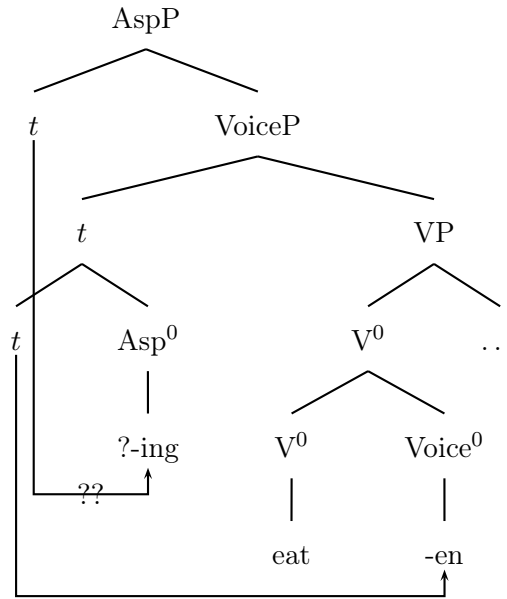

We might imagine that this is exactly the context in which Asp^0 would be stranded, if it remains *in situ* as a consequence of not having any target to Lower onto. If this were the case, however, Asp^0 itself would be in a position to combine with T^0 (by Lowering or Raising), and would then have the heads [Asp^0 - T^0] and [V^0 - Voice^0]; such a structure would give rise to only one auxiliary, rather than the actually attested (in English) two: *was being eaten*.⁶⁹

A similar problem arises in the case of Raising: if auxiliaries do not correspond to independently-merged heads in the syntactic derivation, then we will encounter the paradox of attempting to raise *to* some inflectional projection while also raising the raised-to projection *on its own* to some yet-higher position.

Different problems arise for another variety of the Lowering approach to verbal inflection, framed as a morphological rather than syntactic process within DM: Merger under adjacency (specifically, structural adjacency: Embick and Noyer, 2001). The mechanism of Fission could allow inflectional affixes to split off from their associated functional head prior. If this Fission occurs *prior* to the inflectional affixes undergoing Merger (Lowering) to a lower position, this would be behind the original head as a target for Merger (Lowering) from a yet higher position, resolving the conflict illustrated in (103).

Merger, however, is a process constrained by structural locality: an element can Merge only with the head of its immediate complement. Because Merger is a post-syntactic op-

⁶⁹Were it possible to Lower onto an empty category, this problem would be resolved, but at the expense of remaining entirely faithful to the idea of an “empty category”.

eration, this presents a problem in English in contexts in a head such as Asp^0 or Voice^0 moves to T^0 across negation. As stated in section 2.3.5, I assume that head movement is not post-syntactic, but occurs in the narrow syntax (Lechner, 2006; Matushansky, 2006, et seq.). A head such as Asp^0 would thus move to T^0 , across negation, prior to morphological Merger taking place. In this case, however, the presence of Neg^0 below T^0 and above V^0 should prevent participial morphology from Merging with the main verb, just as it has been claimed to do in the environments of DO-support. This post-syntactic Merger approach to inflection could be rescued by proposing that auxiliary verbs are projected, but the arguments against that approach still stand.

In conclusion, both classical syntactic approaches to Lowering and more recent morphological implementations in terms of Merger are incompatible with the view that auxiliaries are not syntactically represented in the syntax, the position motivated in section 2.2 by the existence of the overflow pattern of auxiliary use.

2.5.2 Implications of reverse Agree

We have now seen additional evidence, empirical and conceptual, in favour of the view that verbal inflection is syntactically manipulated in the form of abstract inflectional features, rather than as discrete heads. The operation responsible for the manipulation of abstract features in current syntactic theory is Agree.

Unlike Raising and Lowering, Agree (as originally formulated by Chomsky (1998)) is not compatible with the view that inflectional information originates higher than the verb. I proposed in section 2.3.1 that the best resolution to this problem is that the directionality of Agree be reversed. The definition of Agree I proposed is repeated from (23) in (104):

(104) *Agree*

Agree is a relationship between two features such that an unvalued feature $[\text{F}:_]$ receives the value of a feature $[\text{F}:\text{val}]$ of the same type iff:

- a. A head α containing $[\text{F}:_]$ is c-commanded by a head β containing $[\text{F}:\text{val}]$.
- b. There is no head γ containing a matching feature $[\text{F}:(\text{val})]$, such that γ c-commands α and β c-commands γ .

This formulation of Agree allows inflectional feature values to be passed *downward* from

a functional head onto the verb, or onto other functional heads. It resembles independent proposals advanced by Adger (2003), Baker (2008), Zeijlstra (2008, 2010), Haegeman and Lohndal (2010), Merchant (2011), and Wurmbrand (2011), addressing various empirical domains. The reader is referred to these sources for specific arguments in favour of reverse Agree, over other possible modifications of the Agree framework, in a variety of empirical domains.

Reversing the directionality of Agree does, however, raise a number of questions. The remainder of this section discusses some of these, in an effort to clarify some of the issues that do face the adoption of a reverse Agree account of verbal inflection.

Chomsky's original formulation of Agree – as triggered by the presence of unvalued features on the *higher* of two heads, rather than the lower – was motivated at least partially by the existence of morphological φ -agreement with post-verbal subjects, such as in existential *there*-constructions in English as in (105).⁷⁰

- (105) a. There **is** a book on the table.
b. There **are** three books on the table.

Chomsky proposed that subject agreement is triggered by the presence of unvalued φ -features on T^0 , and that it is this Agree relationship that is responsible for movement of the subject into Spec-TP in languages with an EPP requirement. This constituted a departure from earlier work, in which agreement was argued to occur (at least in some cases) *only* in a Spec-Head configuration, with the source of φ -features c-commanding the position of agreement morphology (Kayne, 1989, et seq.).

On the face of it, these subject agreement facts cannot be described by the formulation of Agree advanced in this chapter. As a first move, we might ask whether Agree is required to be either downward or upward, or whether both are possible. Both Baker (2008) and Merchant (2011) propose that Agree may differ cross-linguistically in ways that affect its directionality. Cross-linguistic variation in the directionality of Agree is insufficient to resolve the conflict we are faced with here: the apparently different directionality of Agree arises even if we confine our attention only to English.

It also cannot be the case that the directionality of Agree is entirely unconstrained: if

⁷⁰Similar facts have been described in a range of other languages, perhaps most famously morphological agreement with post-verbal nominative arguments in Icelandic.

valuation of any unvalued feature could come either from a lower or a higher head, then the same problems would arise in the inflectional domain that were discussed in section 2.3.1 as a problem for allowing upwards feature valuation to be dependent on a Chomsky-style Agree relation. If feature values could be passed in either direction, then any sequence of two functional heads would be expected to be able to “trade” inflectional feature values. It is not simply that verbal inflection requires downwards feature transmission, in other words, it appears to totally exclude upwards feature transmission.

This leaves us with the possibility that the directionality of Agree is simply different in different domains, either because it is parameterized, or because there are in fact multiple “Agree” operations that interact with different types of features. For example, we might expand the definition of Agree from (23) as in (106):

(106) *Agree (variable directionality)*

Agree is a relationship between two features such that an unvalued feature [F:_] receives the value of a feature [F:val] of the same type iff:

- a. One of the following two conditions holds (choice determined by the identity of the feature type F):
 - (i) A head α containing [F:_] is c-commanded by a head β containing [F:val].
 - (ii) A head α containing [F:_] c-commands a head β containing [F:val].
- b. There is no head γ containing a matching feature [F:(val)], such that γ c-commands α and β c-commands γ .

With such a definition of Agree, we could simply stipulate that INFL-features are subject to the requirement in (106a-i), while φ -features are subject to the requirement in (106a-ii).

While such a redefinition of Agree is possible, it results in a less restrictive theory of syntax. With that in mind, I would like to discuss some facts that cast doubt on Chomsky’s (1998) claim that φ -agreement with post-verbal subjects is in some sense a “core” case on which an operation such as Agree should be defined.

In fact, there are a number of phenomena suggesting that morphological agreement is *impoverished* with post-verbal subjects. In the English existential *there* construction, for example, it has long been noted that (for some speakers) the verb *be* can fail to agree with

a following plural subject, as in (107a). Perhaps a stronger judgement is the fact that *coordinated* subjects in the same position strongly prefer *be* to agree with the first conjunct, as shown in (107b-c). When the subject is pre-verbal, by contrast, plural agreement is mandatory with both plural and coordinated DPs, as shown in (108):

- (107) a. %There's some books on the desk.⁷¹
 b. There { is / are } a book and some pencils on the desk.
 c. There { *is / are } some pencils and a book on the desk.⁷²

In Standard Arabic, similarly, ϕ -agreement with post-verbal subjects is impoverished (Fassi Fehri, 1993, a.o.). While verbs in Arabic show morphological number agreement with pre-verbal subjects (108b), this morphology is missing when the subject is post-verbal (108a):

- (108) a. qadim-a (/ *qadim-uu) al-ʔawlaadu.
 came-3SG.M came-3PL.M the-boys-3PL.M
 "The boys came."
 b. ʔal-ʔawlaadu qadim-uu (/ *qadim-a)
 the-boys-3PL.M came-3PL.M came-3SG.M
 "The boys came." (Harbert and Bahloul, 2002, 45, 1)

Outside the domain of subject agreement, ϕ -agreement with participles in French is restricted to underlying objects, but nonetheless is possible only when the underlying object has moved to a position that c-commands the agreeing participle (Kayne, 1989). Participles show agreement for gender and number with the derived subjects of unaccusative and passive verbs (109), and with pre-verbal object clitics and (in some dialects) moved *Wh*-elements (including relative pronouns) (110).

- (109) a. Les filles sont arrivées.
 the girls are arrived.F.PL
 "The girls (have) arrived."
 b. Les chaises sont arrangées.
 the chairs are arranged.F.PL
 "The chairs are arranged."

⁷¹The acceptability of this sentence is considerably reduced if *be* is not reduced.

⁷²The reduced form 's would be grammatical here, as in the (a) example.

- (110) a. Les filles **les** ont lus
the girls them have read.M.PL
“The girls (have) read them.”
- b. La maison que les filles ont peint(e).
the house that the girls have painted.F
“The house that the girls (have) painted.”

Even given the restriction that French participles show φ -agreement only with their internal argument, if Agree involved a φ -unvalued participial verb probing *downward* to find valued φ -features, we would expect to find the same participial agreement in (111), where the objects are *in situ*, as in (110), where they moved. It is impossible, however, for the participles in (111) to show agreement with their objects:

- (111) a. Les filles ont lu(*s) les livres.
the girls have read.(*PL) the books
“The girls (have) read the books.”
- b. Les filles ont peint(*e) la maison.
the girls have painted.(*F) the house
“The girls (have) painted the house.”

On a Reverse Agree account, by contrast, we expect that Agreement can be established only when the element with valued features c-commands its target, as it does in (110) though not in (111).

Even given the restriction that French participles show φ -agreement only with their internal argument, if Agree involved a φ -unvalued participial verb probing *downward* to find valued φ -features, we would expect to find the same participial agreement in (112), where the objects are *in situ*, as in (111), where they moved. It is impossible, however, for the participles in (112) to show agreement with their objects:

- (112) a. Les filles ont lu(*s) les livres.
the girls have read.(*PL) the books
“The girls (have) read the books.”
- b. Les filles ont peint(*e) la maison.
the girls have painted.(*F) the house
“The girls (have) painted the house.”

On a Reverse Agree account, by contrast, we expect that Agreement can be established

only when the element with valued features c-commands its target, as it does in (111) though not in (112).

These various restrictions on φ -agreement with arguments that follow the agreed-with element argue in favour of a generalized reverse Agree approach, and against the proposal the Agree for φ -features has the directionality proposed by Chomsky, while Agree for INFL-features has the directionality proposed here.

This topic requires much further investigation, though the intricacies of φ -agreement with subjects are beyond the scope of this dissertation. A question that immediately arises, if Agree always transfers feature values down the tree, is how even defective φ -agreement is possible with post-verbal subjects. One possibility is that this defective or partial valuation is indeed able to be *dependent* on a reciprocal “downwards” assignment of features. In the case of Agreement with low subjects, the obvious candidate for this licensing of Case features on the subject by T^0 . This would simply reverse the dependency proposed by Chomsky (1998), in which unvalued Case features on a low subject are valued parasitically on the basis of a φ Probe from T^0 .

In conclusion, the directionality required for Agree in the domain of verbal inflection has yet to be fully reconciled with the directionality widely assumed since Chomsky’s original formulation of Agree. I have suggested that the direction in which feature valuation occurs may be parameterized to different feature types, but also that even in the domain of φ -features there is evidence that upward feature valuation is not the basic case of Agree.

2.6 Previous default approaches to auxiliaries

The basic argument of this chapter has been that auxiliary BE must be analyzed as a “last resort” repair strategy, inserted in response to inflectional material that failed to combine with the lexical verb. The primary empirical motivation for this approach has come from the overflow pattern of auxiliary use, which resists a selectional account of auxiliary distribution, as I argued in section 2.2.

Though this approach to auxiliary BE is not widely adopted in the literature, there have been a small number of worked-out proposals developed along these lines. In this section I review several of these previous proposals, concentrating on the respects in which they differ from the system articulated in this chapter. The central problem all of them face is

an inability to generalize beyond the additive pattern of auxiliary use, and to some extent beyond English.

These default approaches to auxiliary BE can be divided into two main camps. The first argues that BE is inserted in response to a *syntactic* requirement that a verb occur in certain contexts: Dechaine (1993, 1995) and Cowper (2010) advance theories of this type. The second proposes that BE occurs (in at least some instances) for purely morphological reasons: the system I have developed in this section belongs in this category, as do the proposals of Schütze (2003) and, to a lesser extent, Dik (1983, 1987).

Both Dechaine (1993, 1995) and Cowper (2010) propose that BE occurs to satisfy categorial selection (c-selection) requirements of functional heads, in environments that lack a verb (giving rise to copular or predicational BE) or in which the main verb has already satisfied the selectional requirements of some lower head.

For Dechaine, a VP headed by BE is projected above a non-verbal category to satisfy the the projection of a VP headed by BE is required to satisfy the c-selectional requirements of a higher head. In (113), for example, VP₁ is projected because Asp⁰ c-selects for a verb (which the nominal predicate cannot provide), while VP₂ is projected because T⁰ also c-selects for a verb:

(113) Sal was being a fool. (Dechaine, 1993, 332, 103b)

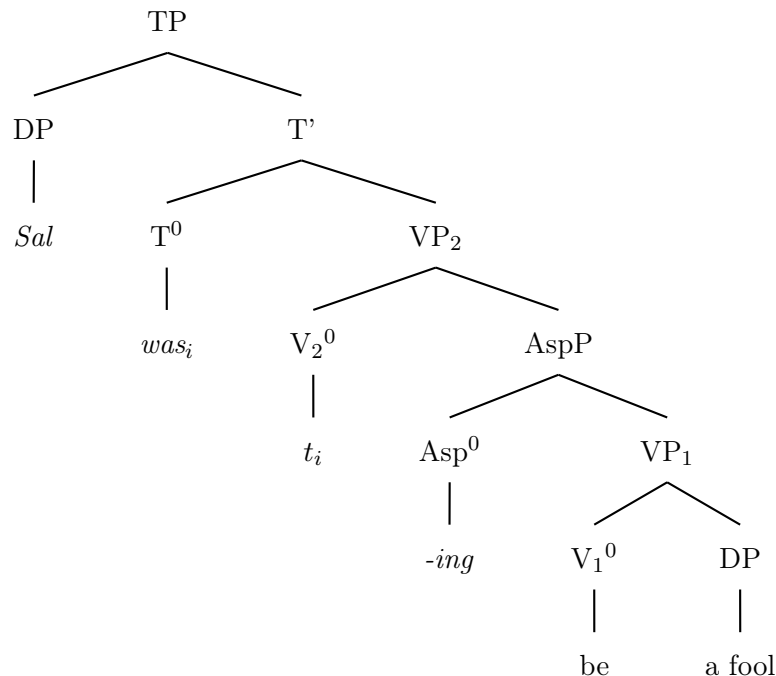

The presence of auxiliary BE is determined, for Dechaine, by a combination of two factors: the requirement that some head X^0 have a verbal complement, together with the fact that phrase that would otherwise be the complement of X^0 is *not* verbal. For this reason, this approach is incompatible with the overflow pattern of auxiliary use: accounting for the overflow pattern would require that *individual* functional heads “counted” as verbal for the purposes of c-selection, but that *combinations* of those heads no longer did and required the insertion of an auxiliary VP.

For Cowper (2010), by contrast, BE does not project its own phrase, but is instead merged directly to the head whose c-selectional requirement for a verb is not satisfied. Following previous work, including Collins (2002) and Adger (2003), Cowper assumes that c-selection is driven by the presence of uninterpretable categorial features on newly merged heads, and satisfied by Agree between the selecting head and a lower head of the appropriate category. Because this view of c-selection is based on Agree, it is possible for a head’s selectional requirements to be satisfied by a head lower than its immediate complement, so long as the lower head is still accessible to Agree.

In the inflectional domain, Cowper proposes that V^0 is merged bearing a set of uninterpretable (but valued) inflectional features, while all higher functional heads in the clausal spine are merged with an uninterpretable categorial V feature ([uV]).⁷³ These subcategorization [uV] features must be checked immediately upon merger, but multiple functional heads can check their selectional feature against V^0 , so long as V^0 retains unchecked inflectional features of its own (i.e. so long as it remains syntactically ‘active’ in the sense of Chomsky (1995)). The uninterpretable inflectional features on V^0 are valued as a reflex of Agree relationship established as the result of a higher head’s c-selection feature.

If V^0 is merged with uninterpretable tense features, then it will remain active until it Agrees with T^0 , and will be able to check the c-selection [uV] features of all intermediate inflectional functional heads.

⁷³The clausal hierarchy and set of inflectional features Cowper assumes are both non-standard: drawing on her previous work (Cowper, 1999, 2003, 2005), she assumes that TAM features are organized into a structured hierarchy, and that the features of this hierarchy are distributed through the following clausal projections:

- (i) Mod⁰ T⁰ Event⁰ *v*⁰ V⁰

Broadly speaking, *v*P is the projection associated with the creation of passives, while EventP is associated with the progressive. The English perfect, for Cowper, involves the iteration of TP: a present perfect is a past-under-present, while a past perfect is a past-under-past (as in Prior (1967)).

If the uninterpretable features on V^0 are checked by any functional head below T^0 , however, subsequently merged heads will be unable to check any [uV] features. Without some other recourse, this would result in uninterpretable features remaining unchecked, and the structure would crash at LF. Cowper proposes, however, that the grammar has a mechanism to “rescue” such stranded inflectional heads. This process is BE-support: if a head is unable to check its uninterpretable category feature immediately upon Merge, it may merge a *default* item to meet its requirement:⁷⁴

(114) **Stranded on Merge:** A head is stranded on Merge, or Merge-stranded, if it has an uninterpretable category feature that cannot be immediately checked. (Cowper, 2010, (5))

(115) BE-support: The verb *be* is inserted immediately to support a merge-stranded Infl head. If the head is affixal, *be* is adjoined to the head. If the head is not affixal, *be* is merged immediately below the head.⁷⁵ (Cowper, 2010, (37))

If augmented by a theory of which uninterpretable inflectional features can co-occur on V^0 , this approach could account for the overflow system. Indeed, the approach must generally be augmented by an independent theory of the features that can be merged on V^0 : without such a theory, it would be possible to merge V^0 with only uninterpretable tense features in a progressive perfect clause: V^0 would remain syntactically active until T^0 was merged, and so the c-selectional requirements of the heads associated with progressive and passive interpretations would be satisfied. Cowper’s proposal also suffers from the same drawbacks identified in section 2.3.1 for any framework in which inflectional feature values are introduced on the main verb.

A further consequence of the system is that auxiliaries are generated at least one head “higher up” than we would expect. All finite auxiliaries, as we have seen, are generated in T^0 , rather than moving there from a lower position, and lower auxiliary verbs are generated

⁷⁴We might wonder if this repair mechanism should be generalized to other environments. In principle, it seems that there would be nothing stopping other categories from fixing their subcategorization requirements in this way.

⁷⁵Cowper extends this proposal to *have*, proposing that what distinguishes auxiliary *have* from *be* is its context of insertion: *have* is inserted to support an instance of T^0 that immediately dominates another instance of T^0 . This context of insertion depends on the view that the English perfect is an “embedded” past tense (Prior, 1967, et seq.). In chapter 3 I argue instead for the Freeze-Kayne analysis of HAVE, which proposes that HAVE reflects the presence of additional syntactic material in the position that otherwise would have been realized as BE.

higher than expected as well: the passive auxiliary, for example, would be generated in any one of a number of higher functional heads, whichever was the first to have its selectional feature stranded.

The important consequence of this is that auxiliary verbs are generated in a *different* syntactic positions depending on the inflectional environment in which they occur. This contradicts evidence from adverb and floated-quantifier positions already reviewed in section 2.3.6. These data are repeated and augmented in (116)- (118), showing that passive *be* and progressive *be* occur in systematically different positions with respect to sentence-level adverbs and floated quantifiers.

- (116) a. The cake is (fortunately) being (*fortunately) eaten.
 b. The cake has (fortunately) been (*fortunately) eaten.
 c. The cake will (fortunately) be (*fortunately) eaten.
 d. The cake seemed to (fortunately) be (*fortunately) eaten.
- (117) a. (progressive *be* cannot occur under the progressive)
 b. The children have (fortunately) been (?fortunately) eating the cake.
 c. The children will (fortunately) be (?fortunately) eating the cake.
 d. The children seemed to (fortunately) be (?fortunately) eating the cake.
- (118) a. The cakes have (all) been (*all) eaten.
 b. The children have (all) been (?all) eating the cake.

Looking beyond English, the fact that tensed auxiliaries are merged directly to T^0 makes it unclear how this proposal could extend to languages without V^0 to T^0 movement for auxiliaries. In the Scandinavian languages, for example, there is evidence from the position of the verb with respect to negation that the main verb remains very low in the clause (in non-V2 tensed clauses). The same word-order facts holds for auxiliary BE. To deal with such cases it would be necessary for Cowper to propose that Merge-stranded T^0 is able to merge a supportive *be* quite low down in the clause, below negation; alternatively, she must propose that negation is a *higher* projection in the tree than TP, and that tensed verbs obligatorily raise from T^0 , past NegP, into a yet higher projection.

In conclusion, while Cowper's rules of BE-support and HAVE-support express the *core* of the intuition that auxiliaries are default elements, the details of the implementation miss

some of the cross-linguistic explanatory power of the analysis developed in this chapter.

An approach more in line with the analysis developed here, though still largely English-centric, is Schütze (2003); Dik (1983, 1987) argues for a related position, though without proposing any concrete mechanism for BE's occurrence. Schütze proposes that English *be* is inserted by the morphological component to fulfill one of two requirements.

(119) The requirement that every clause contain an element of category V^0 .

(120) The requirement that certain inflectional material be spelled out on something of category V^0 .

The second of these conditions resembles my claim in this chapter, articulated most explicitly in section 2.3.6, that certain inflectional elements are morphologically required to be realized on verbs. The first of these conditions in (119), however, is quite different: unlike Cowper or Dechaine, Schütze does not advance an entirely unified analysis of *be*-insertion, though the *defaultness* of the verb *be* is unified as a morphological generalization.

Schütze uses the condition in (119) to account for the fact that auxiliaries appear under modal verbs and infinitival *to*, which for him do not assign inflectional features or affixes that would trigger the morphological need for a verb expressed by (120). Like Cowper, Schütze assumes that modals are associated with a category other than T^0 . This projection is located *below* T^0 for Schütze, and contains not only the “standard” modals but also *do* and non-finite *to*. Elements of this category (Mod^0) do not count as V^0 s for the purposes of the condition in (119). and neither do participles (which Schütze analyzes as heading Part^0 phrases).

Thus, in the sentence in (121), the lexical verb, though non-finite, is not a participle and so satisfies the V^0 -requirement in (119):

(121) The water will evaporate.

In (122a-b), by contrast, there is no lexical verb present in either case, because neither a modal nor a participle counts as a verb:

(122) a. The water evaporating.
b. The water will evaporating.

Schütze proposes that the syntax requires that sentences such as those in (122) contain a V^0 projection above any participles (and below ModP, if present), because neither a modal nor a participle counts as a verb for the purposes of (119). When a V^0 does not contain a lexical verb, the morphological component (which Schütze frames in DM terms) inserts a verb with no properties other than its verb-hood: *be*:

- (123) a. The water [V^0] evaporating. → The water **is** evaporating.
 b. The water will [V^0] evaporating. → The water will **be** evaporating.

For Schütze *be* is not inserted in these contexts to support otherwise-unexpressed inflectional material, because he assumes that in cases such as (123b) there is no morphology assigned by the modal elements that would be expressed by the bare form of *be*.

The requirement in (119) therefore accounts for bare forms of *be*, and is one motivation for the occurrence of tensed *be*.

(120), by contrast, is independent of the need for clauses to contain some verbal projection. It is used to account for the occurrence of participial forms of *be*, and provides another motivation for the occurrence of tensed *be*. Schütze assumes that participial morphology combines with verbs via (short) head-movement. For some reason, however, verbs are stopped from raising further than one participial head – presumably this is an English-specific requirement, as we have seen languages in which verbs do combine with more than one inflectional element.

In a sentence with multiple participial heads (say Passive and Progressive), the higher heads will not combine with a lexical verb. When they reach the stage of morphological realization, Schütze assumes that they spell out with a contentless V^0 “slot”. This contentless V^0 is realized by the morphological component as *be*, for the same reason that the syntactically motivated empty V^0 head was motivated.

What Schütze means by “a contentless V^0 ” is not entirely straightforward, because while it’s clear that he assumes that slot would be filled by the lexical verb, he proposes no mechanism to insert this position in the absence of a verb. At the same time, if a lexical verb counts as something of category V^0 , when it is satisfying the morphological requirements of participial morphology, we would assume that it would be able to satisfy the V^0 requirement on clauses. As it doesn’t, the nature of the V^0 requirement requires clarification.

Another question is at what derivational stage the requirement that every clause contain an instance of V^0 is enforced, and how this requirement can be evaluated without allowing a participial main verb to “count” as an instance of V^0 . It can’t be that something verbal needs to combine with T^0 , because Schütze uses the V^0 requirement to account for untensed auxiliaries below modals (including *to*), in which there is no direct relationship between T^0 and V^0 .

Schütze’s proposal shares with the analysis pursued here the idea that it is the morphological component that inserts *be* in the environments of its occurrence. It diverges, however, in proposing a non-unified analysis of *be*’s environments of occurrence, particularly in proposing that a tensed or sub-modal *be* heads a non-lexical VP, inserted to supply a clause with a verbal projection.

What is missing in Schütze’s analysis, however, is a path forward in accounting for cross-linguistic variability in the distribution of auxiliaries. For example there are languages with auxiliary verbs that don’t require an (overt) verb in every clause: of the languages discussed in this chapter, for example, Latin, Standard Arabic, Kinande, and Basque all allow (and in some contexts require) a null copula. On Schütze’s analysis, this would be unexpected, given that at least some of these are languages in which auxiliary verbs do appear in non-finite contexts.

In summary, a number of previous proposals exist that endeavour to articulate an approach to auxiliary BE that shares the basic intuition with which this chapter started: that auxiliary verbs occur as a kind of “last-resort” response to certain types of inflectional complexity. These previous proposals differ in a number of key ways from the framework I have developed here; for the most part they suffer from being too English specific, and do not offer the *cross-linguistic* unification of auxiliary strategies that has been the goal of this chapter.

2.7 Conclusion

This chapter began by introducing a contrast between two patterns in which auxiliary BE occurs. On the one hand is the *additive* pattern, familiar from the modern Western European languages, in which auxiliary verbs always co-occur with certain inflectional categories. On the other hand is the *overflow* pattern, less widely discussed and rarely identified as impor-

tantly distinct from the additive pattern, in which BE occurs only in certain *combinations* of inflectional categories.

I argued in section 2.2 that the overflow pattern is simply incompatible with the standard approaches to auxiliary verbs one finds in the literature, particularly with purely syntactic selectional accounts. Instead the overflow pattern strongly motivates the view that auxiliary verbs occur in order to realize “extra” inflectional morphology that for some reason was unable to combine with the main verb; and such an approach to auxiliary BE would, moreover, extend straightforwardly to the additive pattern as well.

At the beginning of section 2.3 I listed the requirements this approach to auxiliary verbs places on the formal account of verbal inflection. These requirements are modest: first, that inflection is introduced separately from the main verb; second, that inflection can fail to combine with the main verb; and third, that inflection that fails to combine with the main verb triggers the occurrence of a default verb BE. Though none of these are controversial on their own, the remainder of section 2.3 argued that, when we consider the complete landscape of auxiliary constructions and verbal inflection, we arrive at some perhaps unexpected conclusions.

I adopted an Agree-based system of verbal inflection, in which inflectional information originates as features on associated functional projections. Together with the proposal that inflectional Agree is strictly limited by relativized minimality, due to all inflectional features belonging to a single feature type, this fulfills the first two requirements for the proposed system: inflectional features are introduced separately from the verb, and can be prevented by Relativized Minimality from combining with the verb. The strict locality of Agree, however, is mitigated by two forces: the possibility of some heads not being specified for inflectional features (when their value is default or unmarked), and the availability of head movement, which can move a verb into a local structural relationship with higher functional heads.

The implementation of this system, however, required a non-standard proposal regarding the directionality of Agree: I argued that Agree must be able to transfer inflectional feature values *downward* in the syntactic tree, rather than only upward, as required by its original definition in Chomsky (1998). Implications of this “backwards” formulation of Agree were discussed in section 2.5: in particular, it appears to be in conflict with the availability of upward ϕ -feature valuation, for example between T^0 and post-verbal subjects. I suggested

that the directionality of Agree could be parameterized, but that there is some evidence to suggest that upward φ -feature valuation is often impoverished in ways not seen with downward feature valuation.

The next chapter extends this framework of verbal inflection and auxiliary insertion to auxiliary HAVE, focusing on its interaction with BE in cases of auxiliary selection.

Chapter 3

Auxiliary HAVE: auxiliary selection and related issues

3.1 Introduction

In chapter 2 I argued that auxiliary BE is a morphological reflex of structures in which a certain form of *locality* fails to obtain between inflectional features and the main verb. I contrasted this account with the view that BE is syntactically selected in certain inflectional environments, or that it occurs to accommodate purely morphological restrictions on the number or kind of affixes that can occur on a single verbal stem.

The reason that BE is able to fill this role, I proposed, is that it is a *maximally default* verb: a verb with no properties other than its verb-hood.

This chapter begins to broaden this theory of auxiliary verb insertion. I argue that auxiliaries other than BE are minimally-specified verbs that nonetheless have more highly specified contexts of insertion than BE. Thus, while BE is an *elsewhere* auxiliary, other auxiliary verbs may be inserted in particular categorical or featureal contexts.

This chapter applies this hypothesis to the specific case of auxiliary HAVE:

$$(1) \quad V^0 + [F] \leftrightarrow \text{HAVE} \\ \quad \quad \quad V^0 \leftrightarrow \text{BE}$$

The particular interest of auxiliary HAVE is that there is an extensive literature proposing essentially the analysis in (1), in the context of *auxiliary selection* (Kayne, 1993, et seq.).

In this chapter I argue that this approach is best framed not only within a realizational morphological system, but within the general theory of verbal inflection developed in chapter 2, in which auxiliary verbs correspond to the abstract inflectional features of functional heads.

Auxiliary selection refers to the alternation between BE and HAVE auxiliaries in the perfect; the focus of this chapter is thus on the use of HAVE as a perfect auxiliary.¹ Examples of the English perfect and past perfect appear in (2):

- (2) a. I have read that book twice.
b. I had (already) read the book (when the movie version came out).

While some languages use a uniform HAVE auxiliary in the perfect (such as English, Portuguese, and Spanish), and others use a uniform BE auxiliary (including Finnish, as we saw in the last chapter, and many Slavic languages), many Germanic and Romance languages show *alternation* between HAVE and BE, controlled by a range of syntactic factors.²

In this chapter I argue that the approach to verbal inflection and auxiliaries outlined in chapter 2 can provide an account of auxiliary HAVE in the perfect, and of auxiliary selection, that has both empirical and conceptual advantages over other accounts that have been proposed.

Like Kayne (1993) (and Freeze (1992) for “main verb” HAVE), I will argue that HAVE results from the occurrence of a prepositional element in a position that would otherwise have been realized as BE. Unlike Kayne (1993), however, I propose that this prepositional element *is generated* in that position, and auxiliary selection arises from the (variable) ability of that position to *divest* itself of prepositional features though Agree with a lower element in the clause.

This move is made possible, as we will see later in this chapter, by the proposal that

¹Beyond its core possessive meanings, HAVE does occur outside the perfect. For example, in English *have* also occurs as a causative verb (*She had him make dinner*) and as a universal modal; the HAVE verb *habere* in Latin developed into a future auxiliary as well as a perfect auxiliary in a number of the early Romance languages.

²It is worth noting that the “perfects” under discussion do not form an entirely unified semantic class: while some languages distinguish a true perfect from a simple past perfective, the “perfect” in other languages is ambiguous between these two interpretations. The French *passé composé*, for example, expresses both simple perfective and present perfect interpretations, though the *passé simple* remains in literary use; similarly, in some dialects of German the perfect has supplanted the simple past to express past perfective meanings. This issue does not arise for *past* perfects (pluperfects), however, which in all languages appear to require a clearly perfect interpretation.

auxiliary verbs are not syntactically projected, but instead realize stranded inflectional features. As a result, it is possible to propose that such stranded features may be located on heads that contain *other* features or properties that influence the realization of the auxiliary, for example as HAVE rather than BE. The proposal that featural information can be passed *downward* through the clause, via a mechanism such as “reverse” Agree, will also play a central role, allowing the prepositional feature associated with the perfect to be realized in the position of the auxiliary whenever it has failed to establish a relationship with some lower element in the clause.

Section 3.2 begins by reviewing the cross-linguistic patterns that support the prepositional analysis of HAVE, primarily in the domain of “lexical” uses of HAVE expressing possession, but including prepositional or oblique perfect constructions in some languages.

On the basis of this review, section 3.3 argues for a syntactic representation for perfect constructions in which prepositional features occur on Perf⁰, the head associated with the semantics of the perfect. This proposal is applied in section 3.4 to account for a range of auxiliary selection patterns, particularly argument structure and person/number driven alternations. Section 3.5 compares this account with previous proposals in the literature; section 3.6 concludes.

3.2 HAVE as BE +

As stated in the introduction, this chapter pursues a decompositional analysis of HAVE. This view of auxiliary HAVE is a natural extension of the analysis developed in chapter 2 for BE: both these auxiliaries are default elements inserted to realize stranded inflection, but while BE is an absolutely default verb, HAVE is more highly specified and consequently occurs in more restricted set of environments.

The strongest initial motivation for the incorporation analysis of HAVE comes from correspondences between constructions with HAVE and constructions with BE plus an oblique or prepositional element. These correspondences hold across languages. The majority can be found in the domain of possessive constructions, where languages fall into two basic categories: languages with a lexical verb HAVE, and languages that express possession with a combination of BE and a locatively-marked possessor. As we will see, however, there are limited examples of prepositionally-expressed perfect constructions, primarily from the Celtic

languages.³

The analysis of HAVE as BE plus some additional element is often traced back to Benveniste (1968), who made the observation that *have* has developed *diachronically* from *be* in many languages. Looking at their so-called “main verb” uses, Freeze (1992) was the first to propose that HAVE and BE are *derivationally* related. Freeze argues that existential, locative, and possessive structures all arise from the same underlying (locative) structure, and HAVE results from the incorporation of an oblique or locative element (P⁰) into the position of the copula BE.

A derivational account of the relationship between HAVE and BE as auxiliaries, particularly in languages with auxiliary selection, can be traced to Kayne (1993), who (like Freeze) begins with an analysis of possessive HAVE. Kayne proposes that both possessive and perfect structures involve a (syntactically represented) BE head and an abstract nominal or prepositional head. For Kayne, HAVE results when this abstract nominal/prepositional head incorporates to the position of BE.

A very broad review of the use of BE and HAVE in the marking of possession occurs in Freeze (1992). Freeze’s observations are built around what he refers to as the “locative paradigm”: systematic relationships across languages between locative, existential, and possessive constructions. Existential and possessive constructions in many languages are structurally parallel, both being in a sense the *inverse* of the locative.

The Russian example in (3) provides a typical example. The locative in (3a), the existential in (3b), and the possessive in (3c) all occur with copular BE in Russian. They are structurally distinguished only by the fact that the locative has a prepositional/oblique *predicate*, while the existential and possessive both have a prepositional/oblique *subject*:

- (3) a. kniga byla na stole.
book.NOM.FEM was on table.LOC
Locative: "The book was on the table."
b. na stole byla kniga.
on table.LOC was book.NOM.FEM
Existential: "There was a book on the table."
c. u menja byla sestra.
at 1sg.GEN was sister.NOM
Possessive: "I had a sister."

³Prepositional and locative expressions are more commonly found marking imperfective aspect, particularly the progressive (Bybee et al., 1994).

Freeze gives analogous paradigms for Finnish, Tagalog, Yucatec, and Hindi, among others, and argues that the parallels among the members of the locative paradigm in these languages argues in favour of a single underlying structure for all three, as in (4):

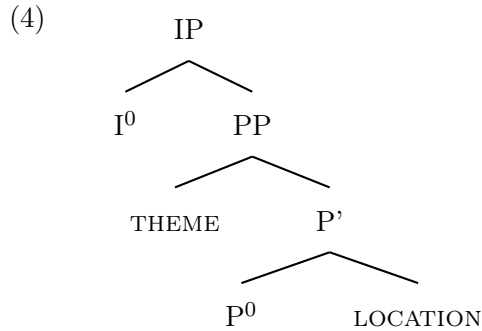

The difference between locatives on the one hand, and existentials and possessives on the other, is whether the THEME argument raises to Spec-IP (in locatives), or whether the LOCATION argument does (in existentials and possessives). Freeze proposes the locative argument moves to Spec-IP if it is [+human].⁴

Freeze extends the analysis of possessives as locatives with a [+human] location to HAVE possessives. While the [+human] status of the possessor has no syntactic consequences for a language like Russian, in other languages we find BE with a locative subject in existentials, but a HAVE verb in possessives. The Austrian German example in (5) is typical:

- (5) a. Der Kuchen ist im KÜhlschrank.
 the cake is in.the.DAT fridge
 Locative: "The cake is in the fridge."
 b. Im KÜhlschrank ist ein Kuchen.
 in.the.DAT fridge is a cake
 Existential: "There is a cake in the fridge."
 c. Ich hab ein Auto.
 I have a car.
 Possessive: "I have (own) a car."

⁴It is not clear that the correct analysis of the existential/possessive contrast should rest on a [+human] feature: *have* allows non-human subjects (*The book has fifteen chapters.*), while existentials seem to allow human locations (*There's someone with her.*). The details of the derivational contrast between HAVE-possessives and BE-existentials, however, are beyond the scope of this dissertation; for expository purposes I follow Freeze in referring to [+human] as the relevant distinguishing feature.

Another point relevant here is that for Freeze it is the P' constituent that moves to Spec-IP in existentials and possessives, leaving the THEME argument *in situ* while preserving oblique/locative marking on the surface subject. The reader is referred to Freeze's paper for discussion of the details of this analysis – what is relevant to us here is only the fact that is cross-linguistically common to express possession by BE together with oblique/locative marking.

It is the systematic cross-linguistic correspondence between HAVE possessives and oblique copular structures that, for Freeze, argues in favour of a derivational relationship between HAVE and BE. Beyond this correspondence, Freeze observes that non-human (or non-animate) subjects of HAVE are interpreted *locatively*, as in *the table has books on it*.

Another parallel between HAVE possessives and locative BE existentials is that both show evidence of the definiteness effect (Milsark, 1977, et seq.). Iatridou (1996) observes that objects of HAVE possessives exhibit a similar definiteness restriction to the one classically observed for the theme argument in existentials, as in (6a): when the object of possessive HAVE is definite, the sentence is interpreted not as true possession, but as a kind of temporary association (6b-c):

- (6) a. There is a/*the car in the driveway.
 b. I have a car. (*have = own*)
 c. I have the car. (*have ≠ own*)

To account for these typological and interpretive parallels between HAVE and locative existential structures, and for the fact that HAVE verbs are in complementary distribution with oblique marking on the subject possessor, Freeze proposes that HAVE results from the incorporation of the locative P⁰ head to the copula BE, triggered by the [+human] property of the locative argument (i.e. the possessor).

Kayne makes similar proposals for possessive HAVE based on Szabolcsi's (1983) analysis of possessive constructions in Hungarian. Hungarian possessive constructions use the copula BE, rather than a possessive verb HAVE, and according to Szabolcsi they are represented as a single possessed DP argument (\approx *the student's book*), out of which the possessor DP may move (if definite), or must move (if indefinite). These are analogous to possessive structures in K'ekchi' (Maya) discussed by Freeze:

- (7) Freeze (1992, 589, ex. 81)

wan iš-soʔsol-č'ič' li išq
 COP [+LOC] 3SG.GEN-dragon.fly-metal the woman
 'The woman has a helicopter.' (lit. 'The woman's helicopter is)

For Kayne, the object that incorporates to copular BE, yielding HAVE, is thus not a locative preposition, but instead an abstract D⁰ "empty prepositional" D⁰ (p. 7) to Be⁰.⁵It

is the incorporation of D^0 to Be^0 that results in the copula being realized as HAVE rather than BE, analogously to Freeze’s claim that incorporation of P^0 to Be^0 produces a HAVE verb.

The distributional relationship between HAVE and BE +oblique structures in the domain of possession motivated Kayne’s extension of this analysis to instances of auxiliary HAVE. We find the same kind of cross-linguistic alternations, however – albeit to a more limited extent – in the domain of perfect constructions themselves.

The most widely known examples of this type come from the Celtic languages, where the perfect (and aspectual categories more broadly) is formed by a copular verb BE followed by an aspectual particle generally homophonous with or related to a preposition. The following example from Scottish Gaelic is drawn from (Reed, 2011), example (10):

- (8) Tha mi air litir a sgrìobhadh
 be.PRES 1SG ON letter TRAN write.VERBAL.NOUN
 ‘I have written a letter.’

Similarly, Lindström and Tragel (2010) show that Estonian, though lacking a verb HAVE, has developed a perfect construction that mirrors its possessive construction. Estonian possessives are of the first type discussed by Freeze: they involve an oblique-marked subject (adessive case-marked) with copular BE:

- (9) Mu-l on uus auto.
 I-ADE be.3SG new car
 ‘I have a new car.’ (ex. (2), p. 374)

A new perfect construction has apparently developed in Estonian that is parallel to this possessive construction, illustrated in (10).

- (10) Mu-l on auto pes-tud.
 I-ADE be.3SG car wash-PASS.PTCP
 ‘My car is/has been washed.’/‘I have washed the car.’ (ex. (1) p. 372)

⁵Incorporation of the “empty prepositional” D^0 to Be^0 is motivated, according to Kayne, in order to allow movement of the surface subject out of the possessed DP (which is in turn required in order for the subject DP to be Case-licensed). Subject extraction must occur via Spec-DP, however, which is an A-bar position, and onwards to the specifier of the copula (Spec-BeP), which is an A-position. This would be an instance of *improper movement* (Chomsky, 1986a,b), and so impossible. Kayne proposes that incorporation of D^0 to Be^0 resolves this issue by allowing Spec-DP to ‘inherit’ Spec-BeP’s status as an A-position. This incorporation, however, results in the surface appearance of HAVE.

Mu-l on juba maga-tud.
 I-ADE be.3SG already sleep-PASS.PTCP
 ‘I have already slept.’ (ex. (22), p. 381)

Lindström and Tragel propose that this construction first developed with transitive predicates, with the participle interpreted attributively (i.e. *I have a washed car*), but show that it has been extended to intransitive verbs as in (11b), where such an analysis is not available.⁶

These cross-linguistic patterns provide evidence for the view that hypothesis that HAVE corresponds in some way to structures in which BE is accompanied by some form of oblique or prepositional marking, not only in its main verb possessive uses, but also in HAVE perfects.

The locative paradigms discussed by Freeze provide compelling evidence that the possessive uses of “lexical” HAVE may result from the *addition* of prepositional material to the position that would otherwise have been realized by BE.

If we understand the trigger for HAVE’s insertion as being the presence of certain *features*, however, we can imagine an alternative scenario: prepositional features could *originate* on the head that will be realized by HAVE, rather than being transferred to that position (whether via incorporation or Agree) in the course of the syntactic derivation.

In what follows, I will argue that this is the correct way to understand *perfect* HAVE: I propose that the head semantically responsible for the perfect (Perf⁰) is introduced into the derivation with prepositional features. If morphologically interpreted in that position, these features will trigger the selection of a default verb HAVE, in place of the totally-default BE, assuming a language *has* a HAVE verb.

Auxiliary selection, on this account, reflects variable circumstances in which these features are *not* morphologically interpreted in the same position as stranded inflectional features, and so do not influence the choice of auxiliary (resulting in the re-emergence of default BE).

Before turning to developing this theory in more detail, section 3.3 lays out the structural assumptions regarding the perfect that will underly this approach. We return to this analysis and its success in the domain of auxiliary selection in section 3.4.

⁶The same diachronic progression has been proposed for HAVE perfects in Romance and Germanic, which are proposed to have originated with stative resultative uses of the past (passive) participle.

3.3 Structure of the perfect

As discussed in section 3.2, the typological relationship between HAVE and BE with oblique or locative marking argues in favour of the proposal that HAVE is itself locative or prepositional in some respect, as proposed by Freeze (1992) and Kayne (1993).

Estonian and the Celtic languages, moreover, present direct evidence that perfects are associated with locative or prepositional content, because locative marking is overt in these languages.

If there is some locative or prepositional element associated with the perfect, however, the question arises of how and where it is represented. This section argues that it should be represented as a prepositional *feature* on the head associated with the perfect, Perf^0 . This diverges from Kayne's proposal (and Freeze's of possessive HAVE) that the perfect contains a separate preposition *head*, that incorporates to a perfect auxiliary BE, yielding perfect HAVE.

The argument for this proposal proceeds in three main parts. First, I establish the motivation for the view, widely adopted in the semantic literature, that the perfect is associated with a dedicated projection, mediating between aspect and tense (and thus syntactically located between Asp^0 and T^0).

Second, I argue that the prepositional element associated with the perfect must be in a very local relationship with this Perf^0 head: even if it is represented as a separate head, it must nonetheless be in a *selectional* relationship with Perf^0 , in order to capture the association between HAVE (or the specific locative marking seen in Celtic and Estonian) and the perfect.

Finally, I argue that this prepositional element must be implicated in the *semantics* of the perfect, again in order to explain the occurrence of this specific prepositional content in the perfect but not in other inflectional contexts. At this point, I argue, no justification remains for distinguishing the head that introduces the prepositional content of the perfect from Perf^0 itself, and consequently it is most natural to represent this prepositional content as a property (i.e. feature) of Perf^0 .

The arguments of chapter 2 apply here, eliminating the possibility that there is a separate, semantically vacuous, projection containing the auxiliary itself, and that HAVE results from the incorporation of Perf^0 itself to this separate auxiliary head.

Taking these points together, I argue against a bipartite representation of the perfect. As a consequence, HAVE cannot result from *incorporation* (which would require at least two positions associated with the perfect), but must involve features that are introduced on the perfect head itself. I argue in section 3.3.4 that this is in line with the use of various locative or prepositional elements to express a range of temporal and aspectual relationships across languages.

3.3.1 A dedicated projection for the perfect

In this section I discuss the arguments in favour of associating the perfect with a dedicated head, for the purposes of semantic and syntactic composition. This was assumed without comment in chapter 2, where perfects in a number of languages were associated with a projection Asp^0 . The perfect auxiliary, I argued, results when inflectional features (originating higher in the clause) are stranded in this position. This basic approach to clausal architecture will be maintained here, but we will see reasons to associate the perfect with an independent syntactic head, distinct from Asp^0 .

Also in chapter 2, section 2.2.1 discussed in general terms the fact that this departs sharply from traditional approaches to auxiliary constructions. The syntactic literature on the perfect is no exception. Particularly in discussions of auxiliary selection, syntactic accounts have tended to take a traditional view of auxiliary-participle constructions, in which a copular verb BE basically takes a nominal or adjectival complement (i.e. the participle). The question of how such a syntax gives rise to the *interpretation* of the perfect is touched on only in passing, if at all.

Kayne (1993), for example, assumes the following clausal structure for perfects, where the embedded DP structure provides the basis of the incorporation yielding HAVE as well as reflecting the ‘nominal’ character of the participle:⁷

- (11) Kayne (1993): Sequence of heads in the Perfect
 $\text{Be}^0 \gg \text{D}^0 / \text{P}^0 \gg \text{AgrS}^0 \gg \text{T}^0 \gg \text{AgrO}^0 \gg \text{V}^0$

Similarly, Den Dikken (1994) assumes that perfects arise in structures with a participial verb and an auxiliary projected either above or below AgrO^0 , but does not comment on

⁷The nominal character of the participle cannot be entirely attributed to the DP layer, however, as Kayne proposes that BE perfects arise in unaccusatives in French and Italian due to the *absence* of this layer.

how this gives rise to perfect interpretations.

The association of the perfect with a dedicated aspectual position is more in line with semantic discussions of the perfect, though these in turn have tended to sidestep the syntactic question of where the auxiliary appears in perfect constructions.

The view that perfects are associated with a dedicated projection Perf⁰ – distinct from other temporal or aspectual projections – follows work by Iatridou et al. (2003), Pancheva (2003), and Pancheva and von Stechow (2004), among others. This is in contrast to approaches that group perfects with other inflectional categories: tense, viewpoint aspect, or Aktionsart. Many traditional descriptions categorize the perfect as a tense; an influential analysis by Prior (1967) proposed that it has exactly the semantics of the simple past, and corresponds to a past-under-present or a past-under-past (in the pluperfect). The perfect has also often been grouped together with *perfective* and *imperfective* aspects as a kind of viewpoint aspect (Giorgi and Pianesi, 1997; von Stechow, 2001), or with resultative Aktionsart or “low aspect” Parsons (1990); Klein (1992, 1994).

A separation between the perfect and viewpoint aspect is motivated, however, by the fact that many languages can express a perfective/imperfective contrast in the perfect (Iatridou et al., 2003; Pancheva, 2003).

(12) *Bulgarian: imperfective/perfective contrast in the perfect*⁸(Pancheva, 2003, 296, ex. 33b-c)

- a. Ivan e strojal pjasâčna kula
 Ivan be-3SG.PRES build-IMPF.M.SG sand castle
 “Ivan has been building a sandcastle.”
- b. Ivan e postroil pjasâčna kula
 Ivan be-3SG.PRES build-PFV.M.SG sand castle
 “Ivan has built a sandcastle.”

(13) *English: perfective/progressive contrast in the perfect*

⁸In addition to perfective and imperfective, Bulgarian has a third “neutral” aspect that can also co-occur with the perfect:

- (i) Ivan e stroil pjasâčna kula
 Ivan be-3SG.PRES build-NEUT.M.SG sand castle
 “Ivan has been building a sandcastle.” (Pancheva, 2003, 296, ex. 33a)

- a. I have written a letter.
- b. I have been writing a letter.

The contribution of the perfect in cases such as these is to *mediate* between tense and aspect. On the view that aspect relates the time of an event to an abstract reference time, while tense relates that reference time to the time of utterance (Reichenbach, 1947, et seq.), it has been claimed that the perfect introduces a time (Pancheva and von Stechow, 2004) or time span (Iatridou et al., 2003) that intervenes in the relationship between the time of utterance and the reference time.⁹

The identification of the perfect with viewpoint aspect – in particular perfective – is understandable, given that in many languages the periphrastic “perfect” is ambiguous between perfect¹⁰ and simple past perfective interpretations. Many of these languages have a non-periphrastic dedicated past perfective form that has fallen into disuse, having been supplanted by the “perfect” inflectional pattern. The ambiguity of the French *passé composé* is illustrated in (14). In some southern varieties of German the perfect has similarly supplanted the simple past to express past perfective meanings.

- (14) Nous avons mangé le dîner
 we have.1PL.PRESeat.PTCPthe dinner
 “We ate dinner.” “We have eaten dinner.”

The past perfect, however, maintains a “true” perfect interpretation in all languages:

- (15) Nous avions mangé le dîner
 we have.1PL.PASTeat.PTCPthe dinner
 “We had eaten dinner.”

The fact that the perfect is able to express simple past meanings in some languages can be attributed to the fact that the perfect can be used to express the anteriority of an event, even in languages with a robust perfect/simple past distinction. The details of semantic

⁹This perfect time span can be constrained by perfect-oriented adverbials such as *since* clauses (Iatridou et al., 2003; Fintel and Iatridou, 2002), which introduce its “left boundary”, with tense (present, past, or future) setting its right boundary.

¹⁰Within the perfect there is furthermore a wide range of possible interpretations, and different subsets of these possible perfect interpretations are available in different languages. See Alexiadou et al., 2003 and references cited therein for a discussion of the range of interpretations available to perfect constructions.

variation in perfect and non-perfect past perfective interpretations is outside the scope of this chapter, which focuses on the syntactic properties of the auxiliary-participle structure used to express the perfect in many languages. Here it is sufficient to adopt the view that perfect structures involve a projection Perf^0 that occurs in the clausal spine as in (16), intervening between T^0 and Asp^0 :

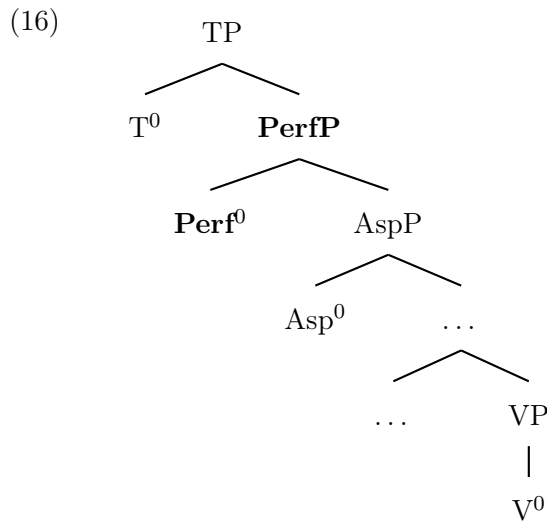

A considerable literature exists discussing cross-linguistic variation in the interpretations available to the perfect, much of it touching on the nature of the *pastness* expressed by the perfect and its variation among languages: see, among others, Prior (1967), McCawley (1971), Dowty (1979), McCoard (1978), Mittwoch (1988), Smith (1991), Klein (1992), Vlach (1993), Giorgi and Pianesi (1997), Parsons (1990), Musan (2001), Fintel and Iatridou (2002), Alexiadou et al. (2003), Iatridou et al. (2003), Pancheva (2003), Pancheva and von Stechow (2004) and Stowell (2008). Within the context of this literature, the semantics of a dedicated head Perf^0 (possibly different in different languages) is a topic deserving further investigation in future work. What nonetheless appears to be well-motivated, however, is the *existence* of this dedicated head in the perfect.

3.3.2 Locating prepositional content in the perfect

Having reviewed the arguments for a dedicated projection Perf^0 in the perfect, we can now ask what its relationship is to the *prepositional* content associated with the perfect. As we saw in section 3.2, the reason to posit some prepositional content in the perfect is not only the use of HAVE as the perfect auxiliary, but also the appearance of *locative* marking in

perfects in the Celtic languages and in Estonian.

Kayne originally proposed that the prepositional content of the perfect is a D^0/P^0 head that is immediately below a copular projection BeP, and that the (variable) incorporation of D^0/P^0 to BE yields HAVE; Iatridou et al. (2003) also propose that perfect structures are bipartite, but argue that a (semantically) vacuous copular projection embeds a nominal head X^0 that yields participial agreement on the verb (or else incorporates to BE, yielding HAVE).

Neither of these approaches assumes the presence of a distinct head Perf^0 ; at the same time, the semantic work motivating the existence of a syntactic Perf^0 projection has tended to ignore the question of where auxiliaries occur. It is often assumed that semantically vacuous auxiliary phrases can be introduced in the syntax in order to derive periphrastic perfect structures.

Chapter 2 argued at length against the existence of syntactically projected auxiliary phrases. Not only are they (often by definition) semantically unmotivated, it was shown that they introduce serious syntactic problems when we consider certain patterns of auxiliary use, i.e. the *overflow* pattern.¹¹

We can nonetheless recast approaches such as Kayne’s and Iatridou et al.’s as claiming that the element that incorporates to BE, yielding HAVE – an element section 3.2 argued is prepositional in nature – is located *high* in the clausal structure, in the part of the clausal structure associated with the perfect.

Other authors have proposed, quite differently, that the element that yields HAVE rather than BE originates low in the clause, separately from the position in which Perf^0 occurs.

¹¹The Latin perfect-passive paradigm in (i) (repeated from (12)) is an example of the overflow pattern: no auxiliary occurs in either the simple perfect or the simple passive, but an auxiliary is required in the perfect passive:

- | | | |
|----|---|--------------------------|
| a. | Puellae crustulum consumpserunt. | <i>Perfect</i> |
| | girl-PL.NOM small.pastry-ACC eat-PL.PFV | |
| | “The girls ate the little pastry.” | |
| b. | Crustulum consumitur. | <i>Passive</i> |
| | small.pastry-NOM eat-PRES.PASS | |
| | “The little pastry is (being) eaten.” | |
| c. | Crustulum consumptum est. | <i>Perfect + Passive</i> |
| | small.pastry-NOM eat-PASS.PTCP be.3SG.PRES | |
| | “The little pastry was / has been eaten.” | |

Discussing examples like this, I showed that postulating an AuxP in overflow contexts such as (16c) is not only problematic, but also unnecessary. I argued that the auxiliary in such examples should instead be understood as a default realization of stranded tense features on an aspectual head, there identified as Asp^0 but which we can now (more accurately) label Perf^0 .

Hoekstra (1999), for example, proposes that it is the position associated with transitivity – for him, the introduction of an external argument – that yields HAVE rather than BE; we can associate this with *vP*, which is a projection not only lower than Perf^0 , but also clearly lower than Asp^0 . In a similar vein, Coon and Preminger (2011) propose that the preposition that incorporates to the auxiliary, resulting in HAVE, is generated in the lower parts of the clause.¹²

What unifies these two proposals is the idea that HAVE is the result of some kind of *long distance* relationship between the position of the auxiliary and a prepositional or transitive element in the lower parts of the clause.

The problem with this *non-local* proposal is that it raises the question of why the specific prepositional element that yields HAVE, or that we see overtly in Estonian and Gaelic, occurs only in the perfect, and not in other syntactic contexts. To account for the fact that this prepositional content occurs *only* in perfects (or in possessive contexts), it must be *selected* by the perfect – or indeed, be in some yet closer syntactic relationship, as I will suggest below.

To put this another way, we know that HAVE occurs as an auxiliary in the perfect, but not as an auxiliary in other inflectional contexts, such as the imperfective, the progressive, or the passive. Given the hypothesis, argued for in section 3.2, that HAVE results from the added presence of prepositional material in the position realized by the auxiliary, it must be the case that this prepositional material is introduced as part of the structure of the perfect itself – if it occurred independently in the clause, we would expect it to potentially influence the realization of other BE auxiliaries in the same way it influences the realization of the auxiliary HAVE.

This is an argument in favour of a local relationship between some prepositional element and the head Perf^0 , roughly as originally proposed by Kayne, and against later proposals that have associated this prepositional material with the lower parts of the clause.

3.3.3 There is no independent P^0 in perfects

So far we have established that there is a dedicated head Perf^0 that is involved in the semantic composition of the perfect, and that this head is in a *local* relationship with some

¹²Coon and Preminger’s proposal is part of a broader theory of ergative splits. It is discussed at slightly greater length later in the chapter.

prepositional element that can cause the perfect auxiliary to be realized as HAVE rather than BE, or that can be realized as an aspectual particle (in Celtic languages) or as locative marking on the subject (in Estonian).

The argument that there is some prepositional content in the perfect, however, does not require that there is a separately instantiated prepositional head. We could imagine instead, for example, that the prepositional element that results in auxiliary HAVE is simply a *feature* of the head Perf^0 itself. In this section I argue in favour of this perspective on the prepositional element involved in the perfect; as we will see in subsequent sections, this allows a novel approach to the issue of auxiliary selection, one that interfaces well with the proposals of chapter 2.

If the perfect *were* to contain a distinct head P^0 , we can ask what the *interpretive* contribution of that head could be. There are basically two possibilities: either it is semantically vacuous, or it is involved in the composition of perfect interpretations, together with Perf^0 .

If it were semantically vacuous, however, we would once again face the question of why it occurs in the perfect, but not in other inflectional contexts. One possibility would be that it makes some *syntactic* contribution, a contribution required by the perfect but not other inflectional categories. There is no evidence, however, for any uniform syntactic deficiency in the perfect that would call for the presence of a semantically vacuous prepositional head.¹³

If the prepositional content associated with the perfect is somehow semantically *contentful*, however, it becomes unclear that we want to associate it with an independent syntactic head P^0 . Consider: if the head P^0 is involved in the semantic composition of the perfect, in what sense could it be making a *separate* contribution from Perf^0 itself? There is no evidence that the semantic composition of the perfect involves the interaction of two distinct heads. Thus, if the prepositional content of the perfect is involved in the *meaning* of the perfect, it is natural to propose that it should be *identified* with Perf^0 .

More specifically, I propose that the prepositional element that results in auxiliary HAVE originates as a prepositional *feature* ([P]) on the head Perf^0 . Thus, this prepositional element is not manipulated in the syntax like a head, by movement operations such as incorporation,

¹³It has been proposed that the syntactic content of the element yielding HAVE is to provide Case for the object, given the *detransitivization* of the participial verb (Hoekstra, 1994, 1999; Den Dikken, 1994). This proposal rests on the observation that the perfect and the passive share a participial form. This analysis does not extend to languages in which auxiliary selection is *independent* of transitivity, however, such as the Italian dialects in which the choice between HAVE and BE is determined by the person and number of the subject. Nor does it extend to languages such as Estonian, where the participial form is not in fact the same in the perfect and the passive.

but instead like a feature, by abstract operations such as Agree.

3.3.4 Prepositional features on Perf⁰

In the previous section, I argued that the prepositional content expressed in the perfect by HAVE or by the locative marking in Estonian and Celtic perfects is best understood as a prepositional feature located on Perf⁰ itself. All other options, I proposed, require a *bipartite* structure for the perfect that is unjustified.

This conclusion might appear at first to be strange or counter-intuitive: I am proposing that there are locative features on a temporal/aspectual head.

We know, however, that tense and aspect categories are frequently expressed, across diverse languages, by locative elements such as prepositions, or by grammaticalized auxiliaries that were originally verbs of location, motion, or position, such as *go*, *come*, *sit*, *stay*, etc (Bybee et al., 1994; Demirdache and Uribe-Etxebarria, 2000; Anderson, 2006, p. 341-5). Given this, the proposal that aspectual heads in general, and Perf⁰ in particular, are associated with formal features *shared* by prepositional or locative vocabulary items is neither strange nor counter-intuitive.

While the prepositional content of Perf⁰ resembles the preposition involved in possession, for example, the prepositional content associated with imperfective or progressive aspect might share more in common with other locative elements, accounting for its association with auxiliaries grammaticalized from verbs meaning SIT or STAY (Bybee et al., 1994; Anderson, 2006, p. 341-5), and a category such as inceptive aspect might be associated with locative/prepositional features that account for its being associated with locative auxiliaries such as COME.¹⁴

Essentially, HAVE is a verb expressing an abstract prepositional meaning. In possessive constructions, this may be, as Freeze proposes, the result of incorporation of a separate preposition; in the perfect, however, I argue that it is a result of abstract prepositional

¹⁴This association is more abstractly appealed to by Demirdache and Uribe-Etxebarria (2000), building on Hale (1986) and the temporal semantics of Klein (1994, et seq.). Demirdache and Uribe-Etxebarria propose that tense and aspectual meanings are fundamentally *prepositional*: they express a relationship between a *figure* and a *ground*. For tense, the figure is the utterance time and the ground is the reference time; for aspect, the reference time is the figure and the event time is the ground. While they do not propose a prepositional element in the *syntax* of temporal relations, they similarly appeal to the widespread use of locative items to express temporal relationships in support of their approach.

If such semantic-lexical correspondences exist, they must be mediated by the syntactic representation: aspectual heads must have properties – which is to say *features* – in common with prepositional or locative items.

features associated with Perf^0 itself.

As suggested in this discussion, this general approach to the relationship between temporal expressions and locative expressions has the potential advantage of beginning to explain why auxiliary HAVE does not occur in other aspectual/inflectional contexts: HAVE occurs only in the perfect because only the perfect has prepositional content analogous to possessive structures. Other aspectual categories are associated with different prepositional relations, so we find different locative categories expressed by their auxiliaries (if at all). If HAVE resulted instead from the incorporation of a (semantically vacuous) prepositional head, as in Kayne (1993), or of a head responsible for participial agreement, as in Iatridou et al. (2003), there would be no reason at all for that same head not to occur in other inflectional contexts, expanding the distribution of HAVE auxiliaries. This explanation is only explanatory, however, to the extent that a common core prepositional content can be identified for both perfect and possessive constructions.¹⁵

Of the two, the prepositional content of possessive HAVE is easier to identify, being more often overtly expressed. The locative content possessive constructions discussed by Freeze is generally highly abstract, involving oblique (genitive or dative) marking on the possessor, or a preposition such as *at*. Though English HAVE is not overtly prepositional, HAVE does alternate with the preposition *with* in nominal contexts, as shown in (17); Levinson (2011) discusses this use of *with* in relation to a possessive construction in Icelandic involving the cognate preposition *með*.¹⁶

- (17) a. The place that has 200 flavours of ice cream (is my favourite.)
b. The place with 200 flavours of ice cream. . .
c. *The place that is with 200 flavours of ice cream. . .

The question that now arises is whether perfect HAVE can *also* be identified with an

¹⁵This issue arises equally for accounts in which perfect HAVE results from the incorporation of a separate prepositional head: the question is what possessive and perfect constructions have in common such as they, but not other auxiliary-based constructions, involve a common prepositional content. One answer that has been pursued elsewhere is that both possessive and perfect structures require an abstract prepositional head in order to Case-license their objects, and that it is this Case-licensing preposition that incorporates to BE to yield HAVE (Hoekstra, 1994, 1999; Den Dikken, 1994; Mahajan, 1994, 1997). I argue against the view that HAVE is a Case-assigning alternate of BE in section 3.5; for now it is adequate to observe that when HAVE does not occur, and we see BE with some locative or oblique element in its place, the locative or oblique element appears to have content beyond simple Case-assignment.

¹⁶Levinson argues that the prepositional content that incorporates to BE resulting in HAVE is not actually identical to any overt locative preposition, but is instead a purely abstract preposition P_{poss} .

abstract prepositional content analogous to AT or WITH. Given the anterior interpretations widely available to the perfect, we might expect the perfect to instead be associated with a preposition such as AFTER: in fact, a preposition or particle equivalent to *after* occurs in BE perfects in the Celtic languages (e.g. Welsh, Roberts, 2005; Scottish Gaelic, Ramchand, 1993; Irish, McCloskey and Hale, 1984), and some English dialects (Kallen, 1990; Cottell, 2003). As we have already seen in section 3.2, however, Celtic languages also form perfects with a particle related to the preposition ON. Similarly, we saw that Estonian forms both possessive and perfect constructions with *adessive* case marking on the subject, adessive being the locative case meaning approximately ON.

A preposition meaning ON is at least more similar to AT or WITH (all three indicating close physical proximity or adjacency) than any of these are similar to AFTER. It is perhaps not entirely clear how any of these prepositions would give rise to a perfect interpretation, but that they *can* is clear from the facts in Celtic and Estonian.¹⁷

The proposal that HAVE reflects the prepositional nature of Perf⁰, rather than an independent head P⁰, takes one step towards explaining why BE perfects are not, in most languages, accompanied by an overt prepositional element: the prepositional content of the perfect does not correspond to a separate head, and so would not automatically be spelled out as such in the absence of incorporation to BE.¹⁸ If HAVE reflects the prepositional nature of Perf⁰, however, this raises the question of how BE ever comes to be used as the perfect auxiliary.

In at least some cases it may be that a language lacks a verb HAVE that realizes these features: we will see that this is plausibly the case for some languages with uniform BE perfects, which any “lexical” verb HAVE expressing possession.

In auxiliary selection languages, however, we know that HAVE is available as the perfect auxiliary. I claim that auxiliary BE occurs in these languages when Perf⁰ has divested itself

¹⁷A potentially fruitful avenue of investigation is to consider the prepositional meaning of the perfect not as asserting the *anteriority* of an event, but as asserting that the event is *contained within* a time span established by perfect semantics, in concert with adverbial clauses (Fintel and Iatridou, 2002; Iatridou et al., 2003; Pancheva, 2003; Pancheva and von Stechow, 2004). This is a development of the *extended now* analysis of the perfect (McCoard, 1978; Dowty, 1979, a.o.). This kind of containment relationship is more compatible with the locative content of possessives (AT or WITH), and with the actual occurrence of elements meaning ON in Gaelic and Estonian perfects, than with the anterior AFTER prepositional content assumed for the perfect by Demirdache and Uribe-Etxebarria (2000).

¹⁸The fact that we do see locative marking surfacing in some perfect constructions suggests that these abstract features *can* be spelled out independently; the point is that unlike existential or possessive constructions with BE, which *always* have some locative element, BE perfects generally lack independent locative marking.

of the need to morphologically realize its [P] features.

When will this be the case? Recall that in chapter 2 I argued that inflectional features are morphologically interpreted only the *lowest* position in which they occur, reflecting the fact that features of inflectional functional heads come to be pronounced in lower positions, particularly on the main verb.¹⁹ The condition was formally stated in (37) in chapter 2, and is repeated in (18):

(18) *Morphological realization of inflectional features*

In a sequence of inflectional features $[F_1], [F_2], \dots, [F_n]$ are related by Agree, such that each feature $[F_i]$ c-commands $[F_{i+1}]$, it is the last feature in the sequence (the structurally lowest) that is morphologically realized.

This same principle can be applied to account for the occurrence of BE as a perfect auxiliary. I will claim that when the [P] features of Perf^0 Agree with a lower head – the participial verb – they no longer influence the morphological realization of Perf^0 , and the absolutely default auxiliary BE will realize any stranded features in that position.²⁰

In other words, the alternation between HAVE and BE as auxiliaries in the perfect results from variation in whether the [P] element of Perf^0 can Agree with some lower position in the clause. If it does, it will no longer be morphologically realized on Perf^0 , and so Perf^0 will be realized as BE rather than as HAVE.

3.4 Prepositional HAVE and auxiliary selection

In the last section, I proposed that the use of auxiliary HAVE in the perfect reflects the presence of a prepositional feature [P] on Perf^0 , which in turn reflects the prepositional nature of the perfect (and all other tense/aspect categories; Demirdache and Uribe-Etxebarria, 2000).

The use of BE in the perfect arises in two ways: either a language lacks HAVE entirely, and so [P] cannot influence the choice of auxiliary; or [P] Agrees with some lower position, and so is not morphologically realized on Perf^0 (due to general principles governing the realization of features in the inflectional domain).

¹⁹An important motivating point was the fact that subject ϕ -features are not stranded on T^0 , though they are uninterpretable in that position, when they also occur (via Agree) on the main verb.

²⁰Leaving aside the fact that neither BE nor HAVE is actually present at the level at which these [P] features are manipulated, we can adopt the slogan that HAVE is not BE-plus-X, rather BE is HAVE-minus-X. Hoekstra (1994) frames his analysis in similar terms, though he views the plus-or-minus element as *transitivity* features.

Auxiliary selection languages, I argue, are those in which this latter strategy is *variably* available: that is, there are some contexts in which [P] is not able to Agree with any lower position, and so influences the morphological realization of Perf⁰, resulting in auxiliary HAVE.

To preview the analysis developed below, I propose that [P] attempts to Agree with the same target as Perf⁰'s other features (specifically the inflectional feature [INFL:PERF]). When it does so, we find auxiliary BE. Not being an inflectional feature, however, [P] is subject to a wider range of potential intervenors: when [P] is prevented from agreeing with the inflectional complement, it remains on Perf⁰ and triggers auxiliary HAVE (assuming that a possessive verb HAVE exists in the language).

The next several sections apply this approach to the most prominent of the patterns of auxiliary selection that have been described in the literature.

3.4.1 Uniform HAVE and uniform BE languages

A range of factors contribute to the alternation between BE and HAVE as perfect auxiliaries. In the simplest cases, we find languages that show no such alternation internally, using either a uniform HAVE or uniform BE auxiliary.

English and Spanish are examples of languages that use HAVE throughout their perfect paradigms, illustrated in (19) and (20). Other uniform HAVE languages include Swedish, Portuguese, and some Catalan and Italo-Romance dialects (McFadden, 2007).

- (19) a. She **has** arrived.
 b. They **had** laughed.
 c. The students **have** read the book.

- (20) a. (Ella) ha llegado
 she HAVE.3SG.PRES arrive.PTCP
 "She has arrived."
 b. (Se) habían reído
 they HAVE.3PL.PAST laugh.PTCP
 "They had laughed."
 c. Los estudiantes han leído el libro
 the.PLstudents HAVE.3PL.PRES read.PTCPthe book
 "The students have read the book."

On the other hand we find uniform BE auxiliaries in languages such as Bulgarian, in (21), and Finnish, with data we previously saw in 2.4.3 repeated in (22):²¹ Other uniform BE languages cited in McFadden (2007) include: Scottish Gaelic (Ramchand, 1993), Welsh (Roberts, 2005), a number of Italian dialects (Tuttle, 1986), Slavic languages other than Bulgarian, and some dialects of English (Hiberno-English: Kallen, 1990, Cottell, 2003; Shetland English: Melchers, 1992; Newfoundland English: Clarke, 2004).

- (21) a. Maria **e** pristignala sega.
 Maria be-3SG.PRES arrive-PFV.F.SGnow.
 ‘Maria has arrived now.’
- b. Ivan **e** postroil pjasâčna kula.
 Ivan be-3SG.PRES build-PFV.M.SGsand castle
 ‘Ivan has built a sand castle.’
- (22) a. Lapset **ovat** syö-neet kakku.
 The.children be.PRES eat-PTCP the.cake
 ‘The children have eaten the cake.’
- b. Lapset **olivat** syö-neet kakku.
 The.children be.PAST eat-PTCP the.cake
 ‘The children had eaten the cake.’

As mentioned above, many languages with uniform BE auxiliaries in the perfect lack a “lexical” equivalent of HAVE as well, and instead express possession with the verb BE and an oblique subject (McFadden, 2007). This is the case for some Slavic languages with uniform BE perfects (for example Russian), and the Celtic languages noted above, as well as for Finnish (Sulkala and Karjalainen, 1992).

A uniform analysis is therefore available for these languages and uniform HAVE perfects: in both it is possible to say that the prepositional feature [P] of Perf⁰ remains there throughout the derivation, and is consequently morphologically interpreted in that position. In languages with a verb HAVE, this feature will cause HAVE to morphologically pre-empt BE as the selected auxiliary. In languages without HAVE, by contrast, BE will remain the only candidate for realizing stranded inflectional features.

Other languages with uniform BE perfects, however, do possess a HAVE verb, and so this cannot be the entire story. This is the case, for example, for the dialects of Italian and English with uniform BE, as well as for Bulgarian. We will return to the issue of Italian

²¹The Bulgarian examples are drawn from Pancheva (2003, pp. 296-7), examples (36c) and (33c) respectively.

dialects with a uniform BE auxiliary when discussing those varieties that display auxiliary selection.²²

3.4.2 Alternations based on argument structure

Auxiliary selection has been most widely studied in Germanic and Romance languages. In standard varieties of French, Italian, German, and Dutch, auxiliary selection generally tracks *argument structure*: transitive and unergative predicates select HAVE, while unaccusative (and passive) predicates select BE. The following examples illustrate this basic pattern for French, Italian, and German:

(23) *French*

- a. Elle **est** arrivée.
She BE.3SG arrive.PTCP.F
“She arrived / has arrived.”
- b. Elle **a** joué dehors.
She HAVE.3SG play.PTCP outside.
“She played / has played outside.”
- c. Elle **a** trouvé cet livre
She HAVE.3SG found.PTCP that book
“She found / has found that book.”

(24) *Italian*

- a. **È** andata
BE.3SG gone.PTCP.F
“She has gone.”
- b. **Ha** suonato.
HAVE.3SG play.PTCP

²²Shetland and Hiberno-English, interestingly, pattern with the Celtic languages in expressing the perfect by a uniform BE that *co-occurs* with a prepositional aspectual particle: examples occur in (i) (the Gaelic example is repeated from (8), from Reed 2011):

- (i) Tha mi air litir a sgrìobhadh
be.PRES 1SG AIR letter TRAN write.VERBAL.NOUN
“I have written a letter.”

- (ii) I’m after hearing the news. (Hiberno-English, Cottell, 2003, ex. 7c)

Cottell (2003) shows that Hiberno-English uses HAVE in the experiential and resultative perfects, BE + preposition in the perfect of recent past, and BE alone in the universal perfect. This suggests that these perfects may have subtly different prepositional representations, and that in a particular language only some of these are sufficiently similar to the locative preposition occurring in possessives to trigger insertion of HAVE.

“S/he has played.”

- c. **Ha** trovato quel libro
HAVE.3SG find.PTCP that book
“S/he has found that book.”

(25) *German*

- a. Sie **ist** angekommen.
She BE.3SG arrive.PTCP
“She has arrived.”
- b. Sie **hat** auf dem Hof gespielt.
She HAVE.3SG in the yard play.PTCP
“She has played in the yard.”
- c. Sie **hat** das Buch gefunden
She HAVE.3SG the book find.PTCP
“She has found that book.”

If auxiliary BE in the perfect arises because a feature [P] on Perf⁰ has successfully Agreed with a lower projection, then in these languages this Agree relationship must be possible in unaccusatives and passives, but not in transitives or unergatives. To begin to answer why this might be the case, we can start by asking what the *target* of Agree is in these cases.

One possibility is that the target of Agree is the same as the target of the other inflectional features of Perf⁰: the main verb.²³ To account for the argument-structural alternations described above, [P] must successfully Agree in unaccusatives and passives, but not in transitives and unergatives. This suggests that some element *intervenes* between [P] and V⁰ in the latter case, though not in the former.

We can ask what syntactic element occurs in transitive and unergatives, but in neither unaccusatives nor passives. The obvious answer is the external argument itself, whose presence or absence defines the two categories under discussion – indeed, whose presence has

²³Possible support for this is the fact that in the Celtic languages, where we see overt prepositional aspectual particles, the particle is adjacent to the main verb, potentially distant from the auxiliary. This is shown for the Irish progressive particle in (i):

- (i) **Tá** na leanaí **ag** dul abhaile.
be.PRES the children PROG go-VN home
“The children are going home.”

(Cottell, 2003, ex. 10)

This linear position of the prepositional particle is inconsistent with its being pronounced in a clausal Asp⁰ or Perf⁰ position. We could therefore hypothesize that this represents a case in which [P] has indeed Agreed with V⁰, and is morphologically realized in that lower position ([P] first potentially having fissioned into a separate head).

been argued to be *diagnosed* by the HAVE-auxiliary. The VP-internal subject hypothesis holds that the base position of the subject is in Spec-VP (or Spec-*v*P), below the hypothesized position of Perf⁰. I therefore propose that the subject acts as a defective intervenor for [P]’s Agreement with V⁰: it disrupts the relationship, without itself being a possible target of successful Agreement for [P].

This is represented schematically in (26):²⁴

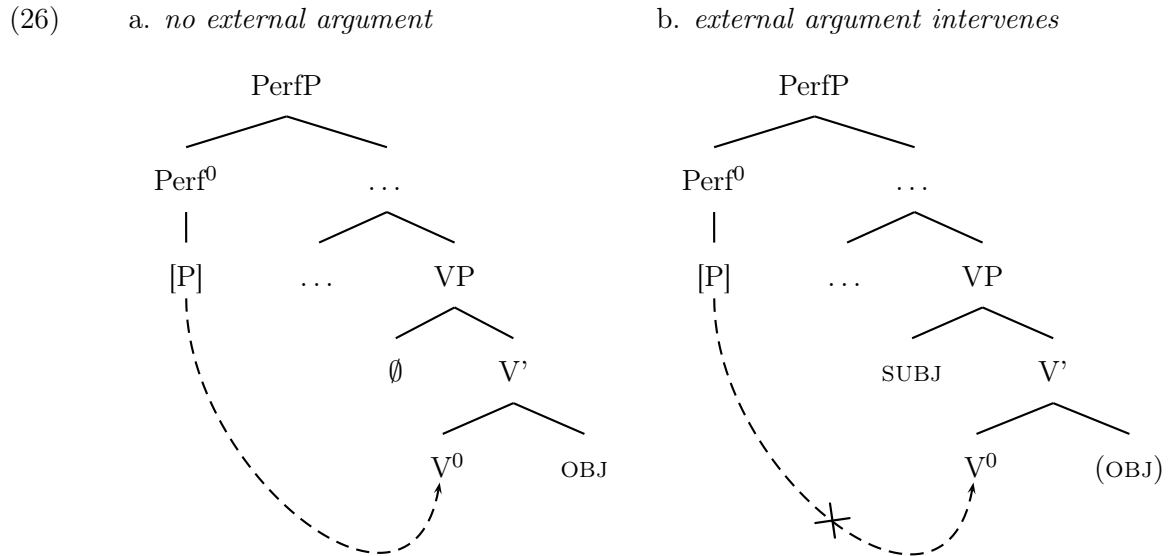

The relevant factor on for argument-structure-driven auxiliary selection on this account is quite simply whether a DP argument intervenes between Perf⁰ and V⁰. When no such argument intervenes – as is the case in unaccusative structures – the feature [P] of Perf⁰ is able to Agree with V⁰, and consequently Perf⁰ itself is able to be realized as BE rather than HAVE.²⁵

This extends straightforwardly to the patterns of auxiliary selection found in *restructuring* environments. As noted by Rizzi (1978) and Burzio (1986) for Italian, and Hoekstra (1984) for Dutch, restructuring predicates in these languages select an auxiliary determined by the *embedded infinitive*, rather than the embedding verb.

²⁴For simplicity of representation, the projections intervening between Perf⁰ and V⁰ are omitted. The subject is introduced in Spec-VP rather than in Spec-*v*P, in order to abstract away from widely-assumed V⁰-to-*v*⁰ movement.

²⁵The prepositional feature [P] does not have any obvious morphological consequence for the main verb, excepting the proposal that in Celtic languages it undergoes fission to be pronounced as a separate particle. Consider, however, that the influence [P] has on the realization of the perfect auxiliary is in triggering the insertion of HAVE over the *totally default* auxiliary BE. In a position containing a lexical root, a verb less default than either HAVE or BE will be inserted in any case, and we might not expect [P] to have any influence on its selection.

(27) illustrates the interaction of restructuring and auxiliary selection in standard Italian (examples from Rizzi, 1982). (27a) shows that the verb *volere* selects HAVE when it takes a nominal complement. (27b) shows that (unsurprisingly) it also selects HAVE when it takes an unergative infinitival complement. (27c), however, shows that when the complement of *volere* is unaccusative, the perfect auxiliary is optionally BE:

- (27) a. Piero ha/*è voluto questo libro
 Piero has/*is wanted that book
 “Peter has wanted that book.”
- b. Piero ha/*è voluto telefonare
 Piero has/*is wanted telephone
 “Peter has wanted to telephone.” (unergative complement = HAVE)
- c. Piero ha/è wanted come with us
 Piero has/is wanted come with us
 “Peter has wanted to come with us.”

The optionality of BE in (27c) is due to ambiguity in whether restructuring has taken place; the following example shows that when the presence or absence of *clitic climbing* disambiguates between restructuring and non-restructuring parses, auxiliary selection must track the embedded verb when restructuring has taken place:

- (28) a. Maria ha/*è dovuto venir-ci molte volte
 Maria has/*is must come-here many times
 “Maria must have come here many times.”
- b. Maria *ci-ha/c’è dovuta venire molte volte
 Maria here-is must come many times
 “Maria must have come here many times.”

Hoekstra (1984) demonstrates that parallel facts arise with restructuring modal verbs in Dutch.

If we adopt the account of restructuring argued for by Wurmbrand (2003), these facts have a simple explanation within the approach to auxiliary selection adopted here. Wurmbrand proposes that restructuring verbs are those optionally able to take a bare VP complement: if an external argument is projected, it must be projected in the Spec-*vP* above the restructuring verb, as the embedded verb does project its own *vP*. Similarly, an unaccusative embedded verb will have the sole clausal argument generated as its complement, resulting in an overall unaccusative structure for the clause.

In other words, Wurmbrand’s analysis of restructuring proposes that the restructuring verb *inherits* the argument structure of the verb it embeds. In particular, whether or not the restructuring verb projects an external argument DP is determined by the embedded verb, and I have proposed that it is the presence or absence of such an external argument that determines whether auxiliary HAVE is selected, by intervening between Perf⁰ and the verb for Agree of a prepositional feature [P].

A more difficult topic is variation within and among languages in the behaviour of apparently unaccusative or unergative verbs with respect to auxiliary selection. Indeed, though auxiliary selection was early identified as one of the diagnostics of unaccusativity (Perlmutter, 1978; Perlmutter and Postal, 1984), it has long been known that it does not match up perfectly with other unaccusativity diagnostics (leading to ‘unaccusativity mismatches’; Levin 1985, et seq.), though languages differ as to which verb select unexpected auxiliaries.

In French, for example, a number of apparently unaccusative verbs – including verbs of motion such as *courir* ‘to run’ and *marcher* ‘to walk’, and the copular verb *être* itself – occur with auxiliary HAVE (*avoir*). This same pattern occurs in other languages; in Dutch, equivalent verbs of motion occur with either *hebben* ‘have’ or *zijn* ‘be’, this alternation apparently depending on their *agentivity* and *telicity*: the greater the agentivity the greater the chance of selecting HAVE, while the greater the telicity the greater the chance of selecting BE (Levin and Hovav, 1995).²⁶ This can even result in alternation in auxiliary selection for a single verb, as in (29):

- (29) a. Jan **heeft** gelopen
 John has walked
 “John has walked.” (Lieber and Baayen, 1997, 807, ex. 16a)
- b. Jan **is** naar de school gelopen
 John is to the school walked.
 “John has walked to the school.” (Lieber and Baayen, 1997, 809, ex. 19b)
- c. Jan **heeft** in de school gelopen
 John has in the school walked
 “John has walked in the school.” (Lieber and Baayen, 1997, 809, ex. 19b)

²⁶Dutch also has a small number of apparently *transitive* verbs that occur with auxiliary BE: *passeren* ‘pass’, *vergeten* ‘forget’, and *volgen* ‘follow’ (Lieber and Baayen, 1997; Hoekstra, 1999). Hoekstra (1984) argues that despite having two arguments, these are nonetheless *unaccusative* verbs in Dutch, in the sense that they lack an external argument (both arguments being generated VP-internally).

Work on the cross-linguistic lexical-semantic correlates of auxiliary selection confirms the impression that BE selection is linked to telicity (and possibly also agentivity), within the domain of unaccusative verbs (Sorace, 2000, 2004; Lieber and Baayen, 1997; Legendre, 2007b; Randall, 2007).

A question arises of how a syntactic approach to auxiliary selection can account for these kinds of alternations, based on lexical semantic properties of the predicate. One possibility is that arguments of atelic or agentive verbs are less likely to be merged as internal arguments: in other words, these factors do not influence auxiliary selection directly, but instead determine whether a verb is in fact syntactically represented as unaccusative. This appears to be the position adopted by Hoekstra (1999), as well as by Randall (2007) and, to some extent, Legendre (2007b). The latter two accounts propose that telicity is (somewhat gradiently) implicated in the linking of arguments to particular syntactic positions. If such approaches are on the right track, the interaction of telicity and auxiliary selection does not in fact fall within the domain of theories of auxiliary selection, but instead is implicated in more general theories of argument structure linking.²⁷

A final point of variation among languages with auxiliary selection driven by argument structure is the auxiliary that occurs with BE itself. In some languages BE unexpectedly selects a HAVE auxiliary in the perfect (as in French and Dutch, among others), while in others BE selects BE.

On the view that BE itself is a lexical verb, with an argument structure like other verbs, the first of these two patterns is particularly surprising: if BE has an argument structure, it is unaccusative, and so should select BE as a perfect auxiliary, rather than HAVE. Within the theory of auxiliaries advanced in this dissertation, however, this variation can be described as arising from different conditions on the locality of [P]'s Agree relation.

²⁷Suppose that the syntactic unaccusativity of predicates is *not* variable in this way. We then want to ask what an account of telicity-based auxiliary selection might look like, within the syntactic account of auxiliary selection proposed here.

One possibility is that the unaccusative predicates that select a HAVE auxiliary are those in which the underlying object has moved to a position before Perf⁰ itself is merged. Of telic and atelic predicates, it is *telic* predicates that more plausibly involve object movement, however: it has been proposed that telic predicates are *delimited* by their internal arguments (Tenny, 1987), and that this delimitedness is the result of the object DP moving to occupy the specifier of a Tel(icity) Phrase located in the *v*P domain of the clause (Borer, 2005, a.o).

We might therefore want to look not at telicity but at *agentivity* as the motivation for object movement that gives rise to HAVE-selection: if agentive uses of unaccusative verbs require their sole arguments to raise to Spec-*v*P, that argument would intervene between Perf⁰ and the verb, leading to [P] being stranded on Perf⁰ and the auxiliary being realized as HAVE.

The argument of chapter 2, that BE is not actually a verb projected in the syntax, is the key component in both cases. Consider, first of all, languages in which BE uniformly selects HAVE: in all such cases, the next inflectional head below Perf^0 does not contain any V^0 for [P] to Agree with. As a result, [P] will remain on Perf^0 , and we expect to find HAVE auxiliaries selected by BE. The second case is languages in which BE selects the perfect auxiliary BE. Once again, because BE doesn't actually occur in the syntax, it cannot be BE itself that determines the choice of the perfect auxiliary; we can propose that these languages differ from those in which BE selects the perfect auxiliary HAVE in that an inflectional head does *not* act as an intervenor between [P] and the main predicate, and so auxiliary selection is determined by the predicates argument structure rather than the verb BE itself.²⁸

Last of all, though our focus here is on the alternation between BE and HAVE, Washio (2004) argues convincingly that an alternation between two different auxiliary verbs in Old Japanese perfects – *-nu* ‘to go away’ and *-tu* ‘to throw away’ – is entirely parallel to familiar HAVE/BE selection in perfects in European languages. The ‘intransitive’ auxiliary *-nu* occurs with unaccusative and passive verbs, while the ‘transitive’ *-tu* occurs with unergative and transitive verbs. Most strikingly, Washio (2004) shows that apparent “exceptions” to these patterns parallel exactly the “exceptions” discussed above for Dutch: otherwise unaccusative verbs select *-tu* in Old Japanese when they are used *agentively* (i.e. unergatively); and a small class of transitive verbs select *-nu*, verbs with the same meanings as some of the transitive verbs in Dutch that exceptionally select *zijn*, including *sugi-* ‘pass’ and *wasure-* ‘forget’ (Washio, 2004, p.220-1).

The existence of auxiliary selection with verbs other than BE and HAVE argues for a *generalizable* theory of auxiliary selection like the one pursued here: if HAVE reflects the presence of additional prepositional material on a head that would otherwise have been realized as BE, as I argue here, then it is straightforward to propose that in some other language, Perf^0 itself might trigger the insertion of a more specified verb – such as *-nu* ‘go away’ – which in turn has a counterpart – *-tu* ‘throw away’ – that expresses similar prepositional content to HAVE.

²⁸Postma (1993) suggests that BE selects a perfect auxiliary BE only if its participial form is suppletive, while it selects HAVE otherwise. If generally true, this is not the kind of generalization that can be captured within the framework advanced here, where morphological information about BE is not present at any stage of the syntactic derivation.

3.4.3 Interlude: reverse Agree

In chapter 2 it was shown that auxiliary verb constructions provide evidence for the view that verbal inflectional features are generated *above* the positions in which they are realized: as a result, these features can be *stranded* from the verb, triggering insertion of auxiliaries. This was implemented by reversing the directionality proposed for Agree by Chomsky (1998): this reverse Agree approach plays a central role in this chapter’s account of auxiliary selection, in allowing the feature [P] to be *generated* in a high position, where it can be semantically motivated, but potentially transferred downward to the main verb via Agree.²⁹

Perfect constructions provide another important argument in favour of reverse Agree. These are the participial agreement facts found in some Romance languages. These have already been discussed in section 2.5.2 of chapter 2, but they are discussed at slightly greater length here due to their widespread discussion in the literature on auxiliary selection.

As we have seen, participles in French and standard Italian show ϕ -agreement with objects, but only with objects that *move* to a position c-commanding the verb, either as the derived subjects of passives and unaccusatives, or (in French) as pre-verbal object clitics or moved *Wh*-elements. This is illustrated for French in (30) and (31):

- (30) a. Les filles sont arrivées.
the girls are arrived.F.PL
“The girls (have) arrived.”
b. Les chaises sont arrangées.
the chairs are arranged.F.PL
“The chairs are arranged.”
- (31) a. Les filles **les** ont lus
the girls them have read.M.PL

²⁹This provides another argument against an approach such as Pesetsky and Torrego (2002, 2006, 2007), where Agree requires a higher head to bear an unvalued (but potentially interpretable) feature, that establishes a relationship with a lower valued feature. It is crucial for the account of auxiliary selection developed here that when Agree for [P] is blocked, the valued feature [P] remains in the *higher* of the two positions that would have been related. This requires that the valued feature [P] *originates* in this higher position, but that Agree is nonetheless possible.

To reframe this account in Pesetsky and Torrego’s terms would lose the motivation for the account. To preserve the idea that HAVE results in the presence of an intervening element – the external argument – we would have to say that it results when the [P] feature of Perf^0 *fails* to be valued by Agree, and that BE results when it successfully establishes an Agree relationship with the main verb. This loses the argued parallelism between perfect HAVE and possessive HAVE, as both resulting from the presence of specific (i.e. valued) prepositional features in the position of the auxiliary. The analysis of auxiliary selection proposed here, if ultimately correct, argues in favour of the view that abstract inflectional information – i.e. features – can originate *higher* than the position in which it is ultimately pronounced. On an Agree-based approach to feature manipulation, this requires a form of reverse Agree.

- “The girls (have) read them.”
- b. La maison que les filles ont peint(e).
 the house that the girls have painted.F
 “The house that the girls (have) painted.”

In the formulation of Agree adopted here, valued inflectional features establish relationships with lower projections that are unvalued for those features. Traditional Agree, by contrast, holds that valuation proceeds syntactically “upwards”, with uninterpretable unvalued Probes establishing relationships with lower valued counterparts. These two views of Agree differ greatly in their applicability to Romance participial agreement.

Even given the restriction that French participles show φ -agreement only with their internal argument, if Agree involved a φ -unvalued participial verb probing *downward* to find valued φ -features, we would expect to find the same participial agreement in (32), where the objects are *in situ*, as in (31), where they moved. It is impossible, however, for the participles in (32) to show agreement with their objects:

- (32) a. Les filles ont lu(*s) les livres.
 the girls have read.(*PL) the books
 “The girls (have) read the books.”
- b. Les filles ont peint(*e) la maison.
 the girls have painted.(*F) the house
 “The girls (have) painted the house.”

On a reverse Agree account, by contrast, we expect that Agreement can be established only when the element with valued features c-commands its target, as it does in (31) though not in (32). The Romance participial agreement facts thus argue in favour of a Reverse Agree approach.³⁰

The question remains, of course, of why participles in these Romance varieties should be able to Agree only with their objects: in principle, a c-commanding subject should also be able to establish an Agree relationship with the participle. Indeed, in Slavic languages such

³⁰ A number of authors have argued for a direct relationship between participial agreement and auxiliary selection, observing that in many standard Romance varieties we find participial agreement always and only on verbs that select a BE auxiliary; Den Dikken (1994) and Iatridou et al. (2003) propose in different ways that auxiliary HAVE and participial agreement morphology should be in complementary distribution. Besides the French facts in (32), however, in a number of Italian dialects we find selection of BE and HAVE determined by the person and number of the surface subject, but participial agreement still controlled only by fronted objects (Tuttle, 1986; Manzini and Savoia, 1998): that is, these languages have the participial agreement pattern of standard Italian, but select auxiliary BE on the basis of entirely orthogonal factors.

as Bulgarian, the uniform BE perfect is accompanied by uniform participial agreement with the subject, including underived subjects; and in some Italian dialects where BE-selection is determined by the person and number of the subject, rather than by argument structure, participles with BE also agree with their underived subjects (Tuttle, 1986).

Given this, it appears that participial agreement in French (and Standard Italian) is subject to more stringent locality requirements than we find generally for participial agreement. Kayne (1989) proposed that participial agreement is possible only in a Spec-Head configuration in these languages, linking participial agreement to verb movement to AgrO. Without adopting that particular view, we can tentatively propose that agreement directly with V^0 in these languages is highly limited: internal arguments that move out of VP pass through a position from which they can Agree with the verb, but external arguments are generated in too high a position to establish that relationship.

3.4.4 Person/Number Driven Alternations

Besides languages in which auxiliary selection is controlled by argument structure, we also find a number of languages – primarily Italian dialects – in which auxiliary selection is determined by the person and number of the subject. As we will see, these cases also admit of an analysis in which HAVE-BE alternations arise due to whether or not a [P] feature on Perf^0 is able to Agree with V^0 .

In person/number driven alternations, auxiliary HAVE is generally associated with third person subjects, while BE is associated with first and second persons: Tuttle (1986) cites this pattern as occurring in Piedmontese, and the dialects of Cori, Roiate/Zagarolo, and L’Aquila/Avezzano/Pescara; Turri (1973, cited by Kayne, 1993) reports the same for Novara; Manzini and Savoia (1998) give full paradigms showing this pattern for Amandola, S. Benedetto del Tronto, Bellante, Pescocostanzo, and Sonnino. The following paradigm from Pescocostanzo is typical:

(33) Manzini and Savoia (1998, from example (23), p. 124)

- a. 'sɔ rla'vartə la 'makina
be.1SG wash.PTCP the car
 “I have washed the car.”
- b. 'ʃi rla'vartə la 'makina
be.2SG wash.PTCP the car

- “You (sg.) have washed the car.”
- c. 'a rla'va:tə la 'makina
have.3SG wash.PTCP the car
 “He has washed the car.”
- d. 'semmə rla'va:tə la 'makina
be.1PL wash.PTCP the car
 “We have washed the car.”
- e. 'se:tə rla'va:tə la 'makina
be.2PL wash.PTCP the car
 “You (pl.) have washed the car.”
- f. 'ianə rla'va:tə la 'makina
have.3PL wash.PTCP the car
 “They have washed the car.”

In the Italian dialect described by Chiominto (1984), HAVE’s distribution is yet further restricted: it occurs only in the third person *plural*, while BE occurs in all other person/number combinations. McFadden (2007) reviews a range of other attested patterns, including: BE only with first person subjects (Girona Catalan); BE in the second-person singular and HAVE elsewhere (Introdacqua); BE in the second person, HAVE in the third, but variation in the first (Castro dei Volsci); and even BE in the *third* singular and HAVE elsewhere (Aliano: Manzini and Savoia, 2007; Legendre, 2007a).

In accounting for the canonical argument-driven cases of auxiliary selection, I proposed that the prepositional feature [P] of Perf^0 targeted the verb, but that DP arguments could intervene for the purposes of this Agree relationship. To account for person/number splits in these Italian dialects, I propose that the feature [P] of Perf^0 is able to target a higher projection than the verb: a head that Agrees with DP arguments specified for a [Participant] feature in the person/number feature hierarchy.

As a first step toward accounting for person/number splits in auxiliary selection, I propose that in some languages [P] can target DP arguments directly, instead of the verb.

Evidence for this can be found in the already-discussed perfect construction from Estonian, repeated from (10) in (34). Here we see that the subject of the perfect is always marked with locative adessive case, regardless of whether the predicate is transitive (34a) or unaccusative (34b):

- (34) Mu-l on auto pes-tud.
 I-ADE be.3SG car wash-PASS.PTCP

‘My car is/has been washed.’/‘I have washed the car.’ (ex. (1) p. 372)

Mu-l on juba maga-tud.
 I-ADE be.3SG already sleep-PASS.PTCP
 ‘I have already slept.’ Lindström and Trigel (2010, 381, ex. 22)

We can account for this pattern of case marking in Estonian perfects by saying that the prepositional feature of Perf⁰ Agrees not with the verb but with a DP argument, resulting in the occurrence of auxiliary BE together with auxiliary BE.

Turning to the Italian dialects with person/number splits, I propose that [P] in these languages also targets nominal arguments, rather than targeting the verb directly. These languages differ from Estonian, I propose, both in not having the elaborate system of locative case marking that allows the [P] feature to be overtly realized on the subject of perfect clauses, but also in *relativizing* the possible targets of [P] to those with more highly marked person/number features.

This rests on the proposal that person/number features are organized into hierarchies, or geometries (Ritter and Harley, 1998; Béjar, 2000; Harley and Ritter, 2002), which provides a fine-grained representation of the markedness relationships between various ϕ -feature specifications. Here I adopt the geometry proposed by Béjar (2000) (the person subpart of which is adopted in Béjar and Rezac, 2009), which appears in (35):³¹

(35) Béjar (2000, 49, ex. 5)

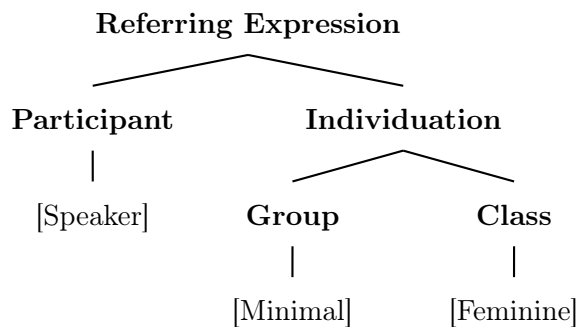

Languages with person/number-splits in auxiliary selection, then, result from [P] being able to Agree only with more DP subjects that bear particular – more highly marked – person/number combinations. In Pescocostanzo, for example, I propose that [P] potentially Agrees only with a DP specified for [Participant], as in the geometry in (35), allowing it to

³¹This geometry also contains specification for gender features, which are not relevant here.

Agree with both first and second person subjects, but not with third-person subjects. In order to *prevent* [P] from Agreeing with first- or second-person *objects*, in the presence of a third-person subject, I propose that just as all DP subjects act as defective intervenors for Agree between [P] and the verb in languages with argument-structure-based selection, third-person DP subjects act as defective intervenors for Agree between [P] and a more highly marked object.

In Girona Catalan, where BE occurs only with *first* person subjects, a similar situation arise, except that agreement with this person/number sensitive head must be relativized to both [Participant] and [Speaker]. As a result, only first person subjects are possible targets of Agree with [P]. Similarly, the cross-dialectal association of HAVE with plurals and BE with singulars suggests that in these varieties singular is the marked number: as a result, it can be specified as a relativized target of [P].

The variation between first and second persons as the core environment of BE selection suggests that there may be variation in the hierarchical representation of these persons, with some languages treating first person as more highly specified, and others treating second person as more highly specified. This reflects cross-linguistic variation in other domains regarding the relevant ordering of first and second on person hierarchies: this is widely discussed in the literature on person splits in ergativity Silverstein (1986, et seq.).

3.4.5 Interim summary

The analysis of auxiliary selection proposed here begins from the proposal that the inflectional functional projection Perf^0 carries some *prepositional* feature [P], in addition to its inflectional feature [INFL:PERF]. This [P] feature syntactically reflects the prepositional *semantics* that Demirdache and Uribe-Etxebarria (2000) propose for tense and aspect distinctions.

The prepositional meaning of the perfect, I propose, is related to the prepositional meaning implicated by Freeze (1992) in *possessive* structures with HAVE. The feature [P] thus triggers insertion of auxiliary HAVE, over auxiliary BE, if it is morphologically interpreted on Perf^0 . This is always the case in languages with a uniform HAVE perfect.

I argued that we can understand auxiliary selection as reflecting a language's variable ability to express [P] in a position other than Perf^0 , by having [P] Agree with a lower element in the clause. Variation among different patterns of auxiliary selection result from

variation in what element [P] targets.

Argument-structure-driven alternations, I proposed, result from [P] targeting the main verb, together with the ability of DP subjects to block this relationship. In transitive and unergative clauses it is therefore the base-generated external argument itself that prevents [P] from establishing an Agree relationship with the verb.

Person/number-driven alternations, by contrast, result from essentially the reverse situation: P^0 targets a nominal external argument, but it relativized to a subset of (more highly marked) φ -features. I argued that Estonian represents a case in which we see [P] targeting a DP argument without such relativization, resulting in visible oblique marking on perfect subjects due to the highly articulated system of case assignment in the language.

The resulting picture of auxiliary selection is a unified one, in which auxiliary selection across the two types of languages operates in essentially the same way, but for the target with which [P] seeks to Agree. Further support for this comes from a *mixed* pattern of auxiliary selection found in a small number of Italian dialects, including Abruzze (Manzini and Savoia, 2007, citing Loporcaro, 1999; Kayne, 1993, citing Loporcaro, 1989), where the perfect auxiliary is uniformly BE in the first or second person, but is determined by the argument structure of the predicate in the third person.

(36) Colledimacina (Abruzzi) (Manzini and Savoia, 2007, 206-7, ex. 22)

- a. so mə'nurtə
 be.PRES.1SG come
 "I have come."
- b. ʎə so ca'martə
 him be.PRES.1SG called
 "I have called him."
- c. e mə'nurtə
 be.PRES.3SG come
 "He has come."
- d. ʎə a ca'martə
 him **have.PRES.1SG** come
 "He has called him."

This complex pattern of auxiliary selection can be accounted for quite simply within the framework argued for here, if the [P] feature in Abruzze targets *either* DP arguments (relativized to more highly marked subjects bearing a [Participant] feature) *or* the verb.

In any sentence with a first- or second-person external argument, this argument will be a potential target for [P], as in (37a). In any sentence without an external argument, the verb will be a potential target for [P], as in (37b). In clauses with a third-person external argument, however, this DP will act as an intervenor between [P] and the verb (just as all external arguments do in languages with argument structural selection), while not itself being a potential Agree target, as in (37c):

- (37) a. *external argument is [Participant]: [P] Agrees with subject*

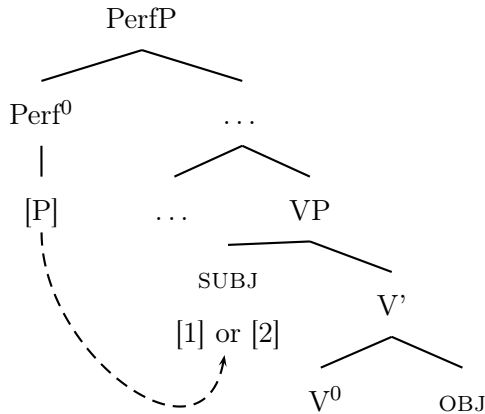

- b. *no external argument: [P] Agrees with verb*

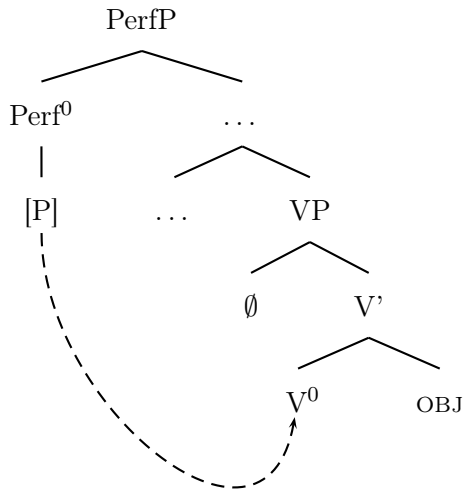

- c. *external argument is not specified for [Participant]: [P] cannot Agree*

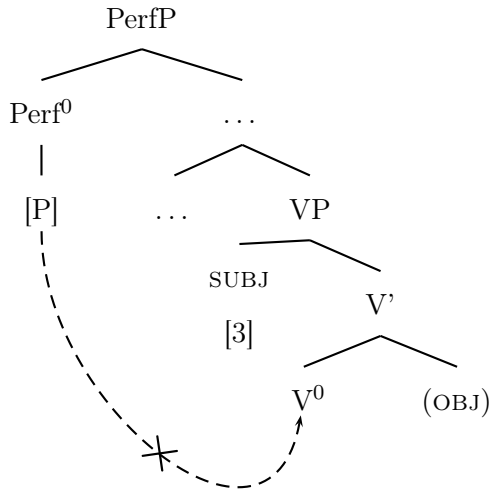

In all these cases the appearance of auxiliary BE reflects the success of Agreement between a prepositional feature [P] on Perf⁰ and some other element; the range of possible targets for that Agreement, moreover, has been justified by the range of positions in which we find overt prepositional or locative marking in perfects: as a verb-adjacent particle in the Celtic languages, and as locative case marking on the external argument in Estonian.

Having laid out how this theory accounts for two major patterns of auxiliary selection, we now turn to some residual cases that have proven challenging for all approaches to auxiliary selection.

3.4.6 Remaining challenges: clitics, tense, and modality

There is a residue of phenomena in auxiliary selection that are not obviously accounted for by the analysis presented in this chapter. This section reviews some of these, including clitic interactions substantially different from those discussed for French and standard Italian, and auxiliary selection determined by non-argumental factors such as tense and modality.

First, the clitic interactions. Kayne (1993) describes two patterns of interaction between clitic use and auxiliary selection that cannot obviously be accounted for here. The first comes from the Italian variety Martinisicuro: citing Masrangellao Latini (1981), Kayne (1993) observes that clitics in this language are able to precede HAVE auxiliaries but not BE auxiliaries. The choice between these two auxiliaries is determined by the person and number of the subject.

- (38) a. Sil-lu ditte.
 BE.2SG-it say.PTCP

“You (sg.) have (=are) said it.”

- b. (A) l’à ditte
 (SUBJ.CL) it-HAVE.3SG say.PTCP
 “He has said it.”

If clitics are associated with a specific position in the clause, and HAVE and BE occur in the same clausal position, then the enclitic/proclitic alternation in (38) has no obvious account. Adopting an incorporation analysis of HAVE, with a separate head P^0 undergoing incorporation to Be^0 , Kayne proposes that the contrast in (38) arises because clitics move out of the participial domain via P^0 , much he proposed that clitics can only extract from non-finite clauses via C^0 (Kayne, 1989). Because clitics must move through P^0 , they can only appear before the auxiliary if P^0 itself adjoins to the auxiliary; doing so yields HAVE, as in (38b).

Kayne’s analysis is not available here. Several other possible analyses, however, are consistent with what has been said elsewhere in this dissertation. First, it is possible that HAVE and BE do indeed occur in different syntactic positions in Martiniscuro. This could be the case if T^0 does not attract an instance of $Perf^0$ that bears the [P] feature, but does attract $Perf^0$ alone. If the position in which clitics occur *interven*es between T^0 and $Perf^0$, this would account for the contrast in (38). Alternatively, it could be that the presence of [P] on $Perf^0$ makes $Perf^0$ a potential target for cliticization, which it may not otherwise be in this language. The choice between these analyses would require a broader investigation of cliticization and clause structure in Martiniscuro than is possible here.

The other interaction between cliticization and auxiliary selection involves the use of clitic *triggering* the selection of an auxiliary. Kayne reports that in Novara (an Italian dialect described by Turri 1973), auxiliary selection is normally determined by the person and number of the subject, with first and second person selecting BE and third person selecting HAVE. What distinguishes Novara, however, is that a HAVE auxiliary is also required whenever the object is expressed as a pre-auxiliary clitic (examples (39) and (40), Kayne, 1993, p. 14, translations added):

- (39) a. Mi i son mià parlà
 Me I am not spoken.
 “I have not spoken.”

- b. Mi i t'ò mài parlà
 Me I you_{dat}-have never spoken
 "I have never spoken to you."

This pattern could be accounted within the framework I have advanced here if the object clitic were located *higher* than the external argument at the point at which Perf⁰ is merged and [P] attempts to Agree with the external argument. In such a configuration, a dative clitic might act as a defective intervenor regardless of its own person/number features, preventing [P] from Agreeing with a first- or second-person subject and resulting in a uniform HAVE auxiliary. Once again, resolving this issue requires a more in depth study of the language in question than is possible here: whether the clitic moves successive-cyclically, and whether the relevant clitics are always dative, are both unclear from Kayne's discussion.

In a very different vein, tense and modality are also known to influence auxiliary selection. Several Italian dialects show variation between the perfect and the pluperfect in auxiliary selection: Ledgeway (2000) gives the following examples from the Procidano dialect of Neapolitan:

(40) Ledgeway (2000, example (4), p. 186)

- a. hó visto a Ciro / arrevèto
 have.PRES.1SG see.PTCP PA Ciro / arrive.PTCP
 "I have seen Ciro / arrived." (present perfect)
- b. fove visto a Ciro / arrevèto
 be.PAST.1SG see.PTCP PA Ciro / arrive.PTCP
 "I had seen Ciro / arrived." (past perfect)

Several languages are also known to show a difference between realis and irrealis contexts in auxiliary selection: most commonly, BE is selected in realis contexts, while HAVE occurs in irrealis contexts (Neapolitan: Ledgeway 2003; Germanic: Johannisson 1958), though Avram and Hill (2007) show that Romanian selects BE in *irrealis* contexts and HAVE elsewhere.³²

(41) Avram and Hill (2007, examples (2) and (3b), p. 48)

- a. Maria a plecat.
 Maria has left

³²See also McFadden and Alexiadou (2005, 2008), who argue that the development of a uniform HAVE perfect in English proceeded in part due to a ban on auxiliary BE in counterfactual (=irrealis) contexts.

- “Maria has left.”
- b. Ar fi plecat.
 would.3SG be left
 “S/he would have left.”

This chapter has argued that, in the core cases of argument structure and person/number determined alternations, auxiliary selection is linked to the interaction of the participial verb and its arguments, in the form of participial agreement. From this perspective, tense and modality driven alternations are unexpected.

I have also argued, however, that auxiliary selection happens in the first place because of the prepositional nature of the perfect. The fact that other temporal categories – in particular tense, which is also interpretively similar to the perfect in some contexts – are also prepositional might lead us to expect interactions with them in the expression of HAVE. I propose that this is the direction in which we would want to look in extending this account to tense and modality driven alternations.

3.5 Other accounts of auxiliary selection

Throughout this chapter, aspects of the proposed analysis of HAVE has been related to previous proposals in the literature, particularly Kayne (1993). With the complete analysis more or less in place, a more direct comparison is possible.

Analyses of auxiliary selection can be divided into three main categories: incorporation driven accounts, in which HAVE results from incorporation to BE (Kayne, 1993; Mahajan, 1994, 1997; Iatridou et al., 2003, a.o.); Case driven accounts, in which HAVE is the transitive counterpart of BE, with the ability to license accusative Case (Hoekstra, 1994, 1999; Den Dikken, 1994, a.o.); and semantic accounts, where the two auxiliaries are gradually linked to properties of the lexical semantics of individual verbs Sorace (2000); Randall (2007); Legendre (2007b, a.o.). We begin in section 3.5.1

3.5.1 Incorporation and auxiliary HAVE

Previous incorporation-based analyses of auxiliary selection have been frequently mentioned throughout this chapter, in many cases motivating key details of the proposal developed here. This section provides the opportunity to review these previous approaches more holistically.

The original incorporation analysis of auxiliary selection occurs in Kayne (1993). As mentioned above, Kayne’s incorporation-based analysis of auxiliary selection has remained widely influential in the literature on auxiliary selection. Its formalization, however, relies crucially on no-longer-current syntactic assumptions, and cannot be straightforwardly reformulated in any other syntactic framework.

Kayne’s analysis of the perfect is developed from his analysis of possessive structures, discussed above in section 3.2. The resulting clause structure involves the sequence of heads in (42), where the embedded DP structure corresponds to the participial verb (reflecting its ‘nominal’ character):³³

- (42) Kayne (1993): Sequence of heads in the Perfect
 $Be^0 \gg D^0/P^0 \gg AgrS^0 \gg T^0 \gg AgrO^0 V^0$

Auxiliary HAVE will occur when the D^0/P^0 head moves and adjoins to Be^0 . This movement is motivated (as in Kayne’s analysis of possessive HAVE) by what would be improper movement from Spec-DP to Spec-BeP (because Spec-DP is an A-bar position, while Spec-BeP is an A-position). Incorporation of D^0/P^0 to Be^0 allows Spec-DP to ‘inherit’ the properties of an A-position.

In languages like English and Spanish, where HAVE occurs throughout the perfect paradigm, this movement always occurs. It is illustrated in (43) for English:

- (43) Alice has written a book.

³³Kayne assumes that essentially an entire finite clausal structure is projected below D^0/P^0 : a VP dominated by two Agr projections with an intervening T^0 head, following the proposals of Pollock (1989) and Chomsky (1993). These projections correspond to the participial verb, and though they are largely peripheral to the analysis of HAVE itself, they will play a central role in determining the occurrence of auxiliary BE in the perfect – i.e. the instances in which D^0/P^0 *fails* to incorporate to Be^0 .

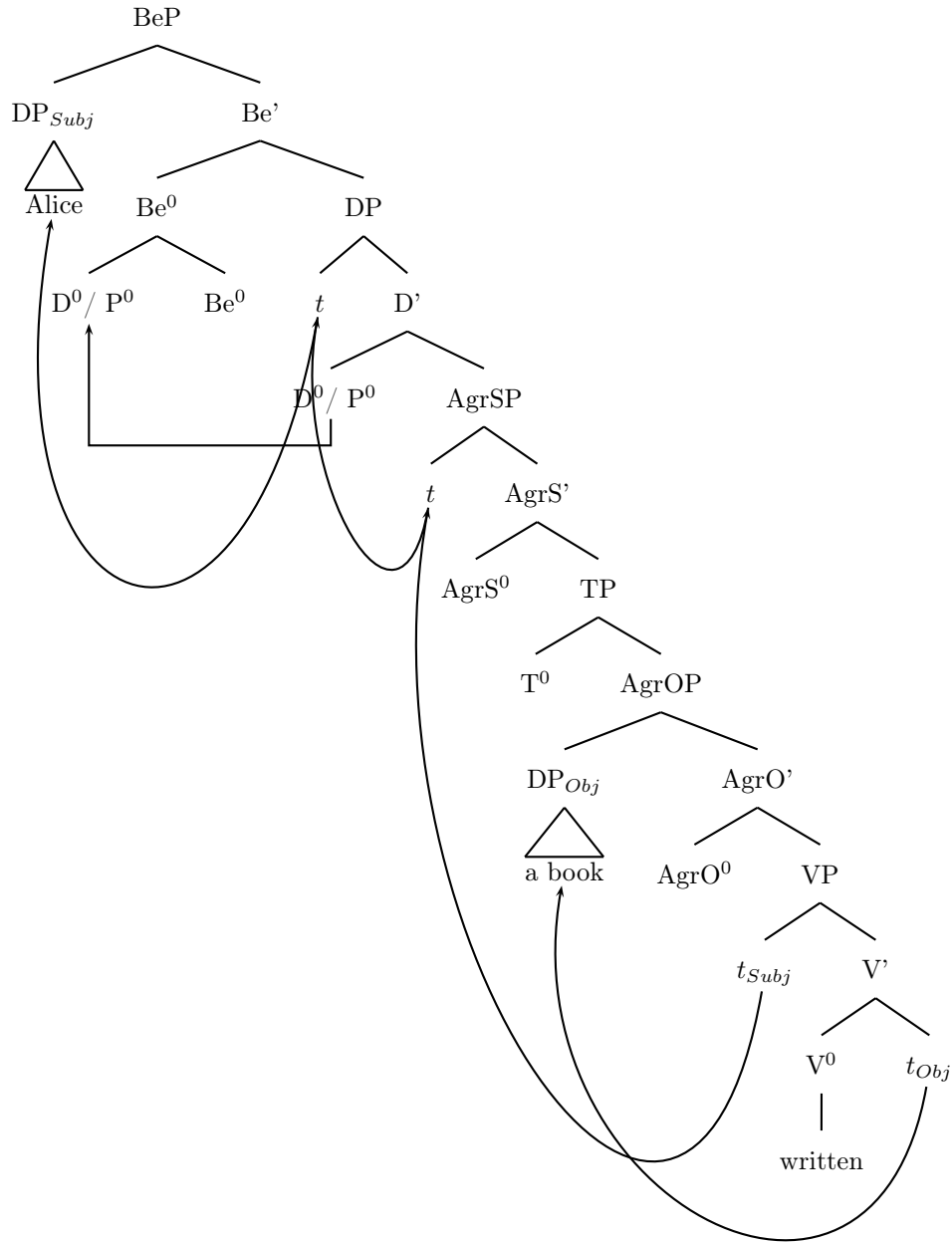

Auxiliary BE occurs, for Kayne, when D^0/P^0 does *not* incorporate to Be^0 . This can happen for one of two reasons: either D^0/P^0 is not projected, or Spec-DP's A-bar status is instead obviated by $AgrS^0$ moving to D^0/P^0 .

Kayne uses the latter strategy – movement of $AgrS^0$ – to account for person/number driven auxiliary selection, as well as languages with uniform auxiliary BE. He proposes that $AgrS^0$ can move to D^0/P^0 only when it has been ‘activated’ by an “appropriate set of person/number features” (p.14) having moved through its specifier. In languages with a uniform BE auxiliary, any subject is able to activate $AgrS^0$ in this way. In languages

where BE occurs only with first and second person subjects, by contrast, Kayne proposes that third-person features, being somehow defective or unspecified, fail to ‘activate’ AgrS⁰. In these latter languages, it is only when a first or second person subject moves through Spec-AgrS, therefore, that AgrS⁰ itself can move to D⁰/P⁰.

In languages with argument-structure-driven alternations, such as French, Standard Italian, German, and Dutch, and in languages with uniform HAVE such as English and Spanish, AgrS⁰ is *never* ‘activated’, and thus never prevents the incorporation that yields HAVE.

Kayne provides a very different account of alternations determined by argument structure. These, according to Kayne, result from representational differences between HAVE-selecting verbs (transitives and unergatives) and BE-selecting verbs (unaccusatives). Specifically, Kayne proposes that these languages (unlike other languages) do not project AgrS⁰ in the absence of an external argument, and the absence of AgrS⁰ allows them to also omit D⁰/P⁰ (for reasons that are not explored).

In the absence of D⁰/P⁰ there is no possibility of its incorporating to Be⁰, and so the auxiliary will always be realized as BE:

- (44) Elle **est** arrivée.
 She BE.3SG arrived.
 “She arrived / has arrived.”

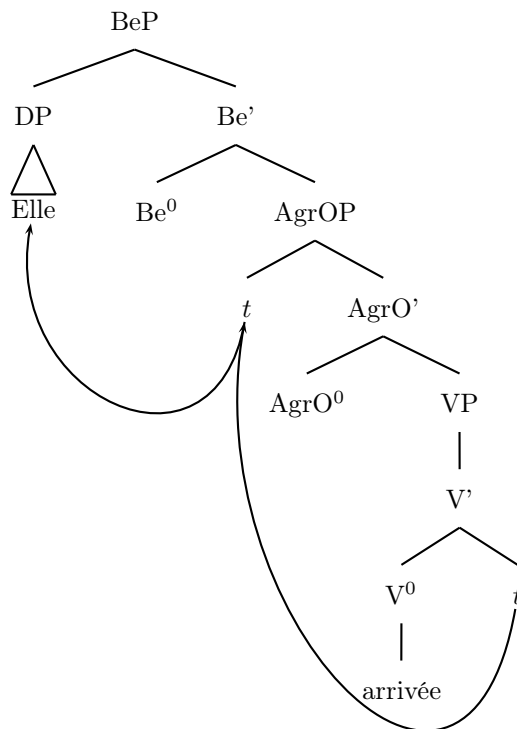

Despite its insights, there are numerous disadvantages to this proposal. The first, from the perspective of today, is that it relies on theoretical machinery that has no direct counterpart in current minimalist syntactic theory. In particular, the incorporation of D^0/P^0 to Be^0 is motivated by the definition of A- versus A-bar positions, and of improper movement, combined with the hypothesis that head movement provides a repair strategy for improper movement. None of these assumptions can be translated into current frameworks: the assumption that the A- versus A-bar status of Spec-XP can be altered by moving the associated head X^0 is particularly curious.

Kayne's approach is also subject to the criticisms that generally apply to bi-partite representations for the perfect, which were developed at more length in section 3.3. In short, it is unclear what semantic content should be associated with the D^0/P^0 head: if it is responsible for the semantics of the perfect itself, then the arguments of chapter 2 apply against the projection of the separate head Be^0 .

An approach developed from Kayne's, but showing interesting differences, can be found in an appendix to Iatridou et al. (2003). These authors propose that perfect constructions involve an abstract nominal head (X^0) immediately below the projection occupied by the perfect auxiliary. This head X^0 is responsible for participial agreement, though only when the participial verb raises to it. When the participial verb remains *in situ*, however, X^0 instead raises to the position of the auxiliary, transforming BE into HAVE along the lines proposed by Kayne:

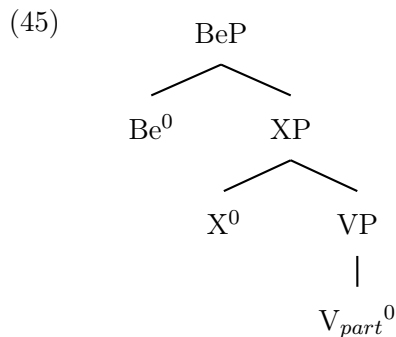

As observed throughout this chapter, the close association between auxiliary BE and participial agreement on the verb breaks down when we look beyond the standard languages, especially in those dialects of Italian that show person/number splits in the perfect. Even in the standard varieties discussed by Iatridou et al., moreover, the same participle that

occurs in the perfect occurs in the passive, and shows participial agreement. To extend this analysis of participial agreement, it would be necessary to propose that a separate head (X^0) occurs in passive structures, and is responsible for participial morphology (and passive interpretations). In order to account for the fact that HAVE never occurs as a passive auxiliary, however, we would have to stipulate that X^0 does *not* incorporate to Be^0 in the passive as it does in the perfect. It is not clear what explanation could be provided for this fact.³⁴

Another interesting development of Kayne's proposal is briefly developed by Coon and Preminger (2011), in the context of a broader theory of ergative splits. Coon and Preminger begin from the observation that splits in auxiliary selection track many of the same properties as splits in ergative case alignment (for which see also Mahajan 1994, 1997 and Manzini and Savoia 1998, among many others): both auxiliary selection and ergative case systems are, in at least some core cases, concerned with argument structural properties of the clause; many ergative splits result in ergative alignment appearing only in perfect or perfective aspects; both auxiliary selection and ergative splits are often sensitive to the person and number of the subject.

Coon and Preminger's account of person splits in ergative alignment involves the proposal that clauses may be bifurcated into two domains for case assignment or competition by a ParticipantP: a phrase headed by the φ -features of the subject. Only visible φ -features can head a ParticipantP – features lower down a (largely) universal person-number hierarchy are less likely to be represented in a particular language.

Auxiliary selection is unified with ergative splits, in this system, by the proposal that ParticipantP also prevents incorporation of Kayne's D^0/P^0 head into the position of a perfect(ive) auxiliary *be*, as in (46):

³⁴Focusing on the distribution of participial agreement, Iatridou et al. do not discuss mechanics of auxiliary selection itself.

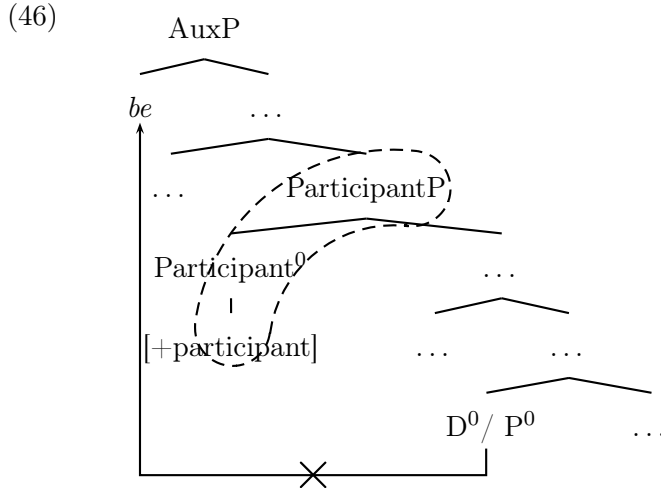

This theory is not further spelled out by Coon and Preminger; in particular, they do not extend their account to auxiliary selection splits conditioned by factors other than the person and number of the subject (or languages without such splits entirely). We might imagine a possible extension, however, if P^0 is associated with the projection that introduces the external argument of a clause, i.e. vP .

The long-distance relationship between P^0 and Aux^0 in (46), however, once again introduces the question of why it is the *perfect* that shows auxiliary selection, and not any other inflectional head above the proposed ParticipantP.

This is one of the key advantages of the proposal developed in this chapter: while maintaining the insights of the incorporation approaches to auxiliary selection – namely, that HAVE is in some sense a *more specified* auxiliary than BE– the fact that $Perf^0$ itself is the source of prepositional semantics and features provides a long-missing explanation of why auxiliary selection with HAVE should be a feature of the perfect, and not of other inflectional categories.

The catalyst for this move is the view that there is no syntactic object BE in perfect (or indeed in any) structures. As a result, we are forced away from the position that it is incorporation to such a head that yields HAVE. Instead, HAVE is simply a more contextually specific (though still default) verb.

3.5.2 HAVE and Case

This section reviews a number of proposals that link the occurrence of auxiliary HAVE to the licensing of an internal argument. In a sense, the division between this section and

the previous one is somewhat artificial: the claim that HAVE licenses accusative Case is not incompatible with the view that HAVE results from incorporation of P^0 into BE (see, for example, Harley, 1995, p. 128). What distinguishes them, however, is the explicit proposal that this abstract head is responsible for licensing the internal argument.

Hoekstra (1984, 1994, 1999), for example, does argue for a relationship between auxiliary HAVE and BE that is related to their “main verb” uses, but unlike Kayne does not frame this relationship as derivational. Focusing on argument-structural HAVE-BE alternations, Hoekstra argues that HAVE is the *transitive* counterpart of auxiliary BE, able to license accusative Case.

This analysis is motivated by the observation that all of the languages that show auxiliary selection use the same participial form of the verb in both the perfect and the passive. On the basis of this correlation, Hoekstra (1984) proposes the “past” participle in these languages is a derived predicate that has been *detransitivized*: for Hoekstra the core property of transitive predicates for Hoekstra is that they have an *external argument*.³⁵ Unaccusative predicates therefore have their argument structure unchanged by the participial derivation, but transitive predicates “lose” their external argument. Both can combine with a default inflectional auxiliary form of BE, but the results will be different in each case: for unaccusatives, this can form a periphrastic perfect(ive), but for transitives the result will be a periphrastic passive.

To form a periphrastic perfect, according to Hoekstra, transitive participles must be “re-transitivized”. This triggers the use of auxiliary HAVE: unlike BE, HAVE brings with it an AgrO projection, which is able to assign accusative Case to the object, and is able to introduce an external argument (linked in some way to the thematic subject of the detransitivized participle).

Hoekstra (1999) suggests that BE may be nothing more than a default expression of inflectional information – in line with the analysis pursued in detail in this dissertation – but maintains that HAVE is more than this: HAVE, according to Hoekstra, occurs in structures with an additional “transitivity feature (TF)”.³⁶ The projection responsible for transitivity for Hoekstra (1994) is AgrO; Schoorlemmer (2007) observes that we might identify it in a

³⁵As a result of this view of transitivity, unergative predicates count as “transitive” for Hoekstra.

³⁶Hoekstra analogizes this transitivity feature to the incorporated element proposed by Kayne (1993) and others. Kayne, however, does not suggest that his D^0/P^0 projection is responsible for Case licensing the internal argument: that role is filled by the embedded AgrO projection.

modern framework with *v*P.

The primary drawback of of Hoekstra’s account of auxiliary selection is that it can be applied only to languages with argument structure driven alternations. It has nothing to say about the Romance dialects where auxiliary selection is determined by the person and number of the subject (despite the same participle occurring in the passive and in the perfect), and also nothing to say about languages like Greek, which employ a uniform HAVE auxiliary despite using a participial form that is *not* used in the passive (the passive in Greek is synthetic).

A similar criticism can be applied to Den Dikken (1994). Den Dikken’s analysis is somewhat similar to Hoekstra’s: he proposes that auxiliary HAVE occurs in contexts where the auxiliary must be able to license accusative Case. His account differs in that it is framed primarily to account for patterns of participle agreement in languages with and without auxiliary selection.

Den Dikken proposes that there are in principle two possible structures for periphrastic perfect constructions. In (47) (= (3), Den Dikken, 1994, p. 66), the auxiliary V^0 occurs below an AgrO projection, while in (48) (= (4), Den Dikken, 1994, p. 66), AgrO *intervenes* between the auxiliary and the main VP:

(47) [IP Spec₁ [I' I [AgrOP Spec₂ [AgrO' **AgrO** [VP₁ SU [V' **V_{aux}** [VP₂ [V' V_{ptcp} OB]]]]]]]]]]

(48) [IP Spec₁ [I' I [VP₁ [V' **V_{aux}** [AgrOP Spec₂ [AgrO' AgrO [VP₂ SU [V' **V_{ptcp}** OB]]]]]]]]]]

Like Hoekstra, Den Dikken proposes that participles are uniformly *detransitivized* predicates, and that a HAVE auxiliary is used when additional Case features are required for a fully transitive structure. Such HAVE auxiliaries will occur in structures such as (48a), with the low V_{aux} , while BE auxiliaries will occur in structures corresponding to (48b), with the low V_{aux} .

Following Baker et al. (1989), who propose that passive participles have a pronominal subject argument introduced in Spec-AgrO, Den Dikken proposes that *all* participial structures have such a covert subject introduced in this position.³⁷ Though the pronominal subject is covert, it must be Case licensed.

³⁷For Baker et al. (1989), this introduced subject is actually the participial morphology; adopting the lexicalist minimalist assumptions of Chomsky (1993), Den Dikken assumes that the participial verb is constructed pre-syntactically, and that the pronominal subject argument is covert.

In languages like French and Italian – languages with auxiliary selection – Den Dikken proposes that the covert subject can be assigned Case by the participial verb when that verb has no internal argument,³⁸ because all verbs have Case features (contra Burzio’s generalization). For this Case assignment to be possible, however, it is necessary that the participial verb incorporate directly to AgrO, something that will only arise in a structure such as (48b). With the Case requirements of these arguments satisfied, there is no need for an auxiliary with Case features of its own, and the auxiliary verb will be BE (were HAVE to occur, its Case features would fail to be checked). The overt external argument, introduced in the specifier of the auxiliary verb, will receive Case in Spec-IP. Den Dikken proposes that such structures are responsible, moreover, for the presence of agreement on the participle, which requires head movement of the participle to AgrO.

In these same languages, when the participial verb is transitive, it must assign Case to its true object. The only source for Case for the covert subject in Spec-AgrO would then be an auxiliary verb. V_{aux} in such structures must occur below AgrO, and must be the Case-assigning HAVE. Such structures do not have the participial verb moving to AgrO, and so lack participial agreement.

To account for languages with a uniform HAVE auxiliary in the perfect, languages such as Spanish and Portuguese (and English), Den Dikken proposes that these languages have participles that are truly deverbal; as adjectives, they are *never* able to assign Case to an unexpressed argument, and so must always employ a HAVE auxiliary.³⁹ This accounts for the total absence of participial agreement in these languages.

Finally, to account for languages with a uniform BE auxiliary in the perfect (such as the dialects of Italian discussed by Kayne (1993), and the Slavic languages with periphrastic perfects), Den Dikken appeals to the existence of *long head movement* in these languages. This allows the participle to move to AgrO across an intervening auxiliary verb, checking the Case of the covert subject and thus allowing the auxiliary to be BE.

Like Hoekstra’s, Den Dikken’s account does not suggest any obvious extension to languages in which auxiliary selection is determined by the person and number of the subject. It is also very much bound up in a theory that includes the postulation of Agr projections,

³⁸Den Dikken assumes that unergative intransitives have a covert cognate object, along the lines of Hale and Keyser (1993).

³⁹In support of this view, Den Dikken cites the absence of bare participial adjuncts in such languages. Bare perfect participle adjuncts are possible in Italian, though not in French.

and in which participial agreement occurs in a strictly Spec-Head relationship.⁴⁰

Both are moreover committed to the view that the perfect auxiliary occurs in a relatively low clausal position: the fact that HAVE licenses an internal argument is captured, for both Hoekstra and Den Dikken, by the fact that it introduces – i.e. selects, or is selected by – AgrO (or perhaps v^0 , in more recent frameworks).

This puts the perfect auxiliary HAVE in a very low clausal position, much lower than the proposed aspectual projection Perf⁰ with which it is associated in this chapter. It is difficult to see how such a low position for auxiliary HAVE can be reconciled with the fact that HAVE appears to be associated with a relatively *high* clausal position, both semantically (based on its compositional meaning) and syntactically (it occurs above most other auxiliaries).

In conclusion, we have seen that approaches that link auxiliary selection to argument licensing and transitivity have been successfully applied to languages in which selection is determined by argument structure (if selection occurs at all). Despite the appeal of such accounts – particularly given their ability to account for the use of a single participial form in both perfect and passive clauses – they face two major difficulties. The first is that they do not extend to languages in which auxiliary selection is determined by other factors, either the person/number alternations that have been accounted for in this chapter, or the tense or modality driven alternations mentioned in section 3.4.6. The second is that they rely on a syntactically close connection between the perfect auxiliary HAVE and the projection responsible for accusative Case and the external argument; this close relationship is entirely at odds with independent evidence regarding the relative syntactic positions of those elements. These drawbacks are shared neither with the incorporation approaches discussed above, nor with the approach to auxiliary selection advanced in this chapter.

3.5.3 Semantic approaches to auxiliary selection

Finally we come to a very different family of approaches to auxiliary selection, those that argue that syntactic considerations are inadequate to account for HAVE-BE alternations, and that semantic factors must be considered instead.

Sorace (2000, 2004) is perhaps the best known of such accounts. Sorace proposes that two semantic factors are primarily responsible for auxiliary selection: *agentivity* and *telicity*.

⁴⁰It is not entirely clear how Den Dikken accounts for participial agreement with external arguments, in languages where this occurs, given that participles never occupy an Agr position in whose specifier the subject occurs.

These two factors divide predicates into a range of categories, which can be arranged on a scale as in (49). This scale is the *Auxiliary Selection Hierarchy* (ASH). Predicates higher on ASH are more telic and less agentive, and are more likely to select BE; predicates lower on ASH are less telic and more agentive, and are more likely to select HAVE.

- (49) Auxiliary Selection Hierarchy (Sorace, 2000, p. 863)
- | | |
|--------------------------------------|--------------------------------|
| CHANGE OF LOCATION | selects BE (least variation) |
| CHANGE OF STATE | |
| CONTINUATION OF A PRE-EXISTING STATE | |
| EXISTENCE OF STATE | |
| UNCONTROLLED PROCESS | |
| CONTROLLED PROCESS (MOTIONAL) | |
| CONTROLLED PROCESS (NON-MOTIONAL) | selects HAVE (least variation) |

Sorace proposes that individual languages may choose different points on the ASH continuum as the dividing point between HAVE and BE selection, but that the ranking itself is constant. The ASH applies only to intransitive predicates.

Lieber and Baayen (1997) represents an earlier account in the same vein, though limited to Dutch and relating auxiliary selection to a single bivalent feature: \pm Inferrable Eventual Position or State. This feature expresses a notion closely related to telicity, and Lieber and Baayen propose that verbs that are [+IEPS] in Dutch uniformly select a BE auxiliary, while those that are [-IEPS] select a HAVE auxiliary.⁴¹

Unlike Sorace or Lieber and Baayen, Legendre (2007b) proposes that a relatively large number of semantic features are involved in defining a class of unaccusative BE-selecting verbs. Analogously to the ASH, however, the majority of these features are arranged into a fixed ordering of implicational relationships: features lower on the hierarchy are implicated by features higher on the hierarchy. The hierarchy is as in (50) (Legendre, 2007b, p. 1524):

- (50) [+inherent displacement] » [+inhomogeneity] » [+telicity] » [+directed change] »
 [+state] » [-inherent volitionality]

⁴¹Washio (2004) adopts Lieber and Baayen's [\pm IEPS] feature in his analysis of Auxiliary selection in Old Japanese. See Hoekstra (1999) for extensive criticism of Lieber and Baayen's account of Dutch.

One feature is involved in determining auxiliary selection that is not included in the hierarchy: this is [+internal motion], which selects a small class of BE-selecting verbs of motion in some languages.

The actual mapping of verbs into either unaccusative or unergative representations is accomplished for Legendre by an OT-style competition on the basis of constraints preferring to map the sole arguments of verbs satisfying these features as external arguments, and a constraint that disfavors forming perfect constructions with unaccusative predicates. Auxiliary selection in turn is determined by competition between a constraint disfavouring HAVE auxiliaries, and a constraint favouring HAVE when a verb has an external argument.

Randall (2007) proposes a semantic approach to auxiliary selection that is framed in response to Sorace's ASH. Randall argues that *telicity* is the sole factor implicated in auxiliary selection, not telicity combined with agentivity as claimed by Sorace. Randall adopts a view of Conceptual Linking in which semantic representations are mapped by a series of rules onto argument structural (syntactic) representations.

The main challenge for semantic accounts of auxiliary selection is in proposing a *mechanism* for auxiliary choice. Of the views surveyed here, only Legendre articulates a mechanism for *translating* the semantic hierarchy into auxiliary choice, and even that mechanism is parasitic on the competition that assigns unaccusative or unergative representations to particular verbs. Rather than providing an account of auxiliary selection, these semantic approaches instead provide a lexical-semantic account of *unaccusativity*.

As with the transitivity based semantic accounts, moreover, the semantic approaches do not provide any obvious extension that would enable them to account for auxiliary selection patterns that are not based on argument structure.

In conclusion, the semantic accounts of auxiliary selection reviewed in this section are fundamentally incomplete: with one exception, each requires a *subsequent* account of why HAVE is selected with transitives and unergatives, and BE with unaccusatives. Indeed, any of the proposals in this section could in principle be consistent with the syntactic proposal articulated in this chapter, or with the syntactic proposals advanced previously in the literature: it may turn out that the variability in auxiliary selection among certain classes of intransitive verbs is due to cross-linguistic variation in how verb classes are mapped to particular syntactic structures.

3.6 Conclusion

This chapter has extended the auxiliary verb analysis of chapter 2, which focused only on auxiliary BE, to the domain of auxiliary HAVE. Following Freeze (1992) and Kayne (1993), I have proposed that HAVE occurs in environments in which *prepositional* material occurs in a position that otherwise would have been realized by the totally-default verb BE.

I proposed that in the case of the perfect auxiliary HAVE, this prepositional material takes the form of a feature [P] that is *generated* on the perfect aspectual head Perf^0 : this links the occurrence of HAVE in the perfect to the occurrence of more clearly locative or motional auxiliary verbs in other temporal and aspectual contexts. This allowed a novel approach to auxiliary selection, in which the alternation between HAVE and BE results not from incorporation of a separate head P^0 or D^0 to BE, but instead from the [P] feature being morphologically separated from Perf^0 in the course of the derivation. This separation occurs only when [P] Agrees with another (lower) position in the clause: I argued that [P] can target either the clausal subject or the main verb itself, with non-target DPs acting as (defective) intervenors in all cases. This range of possible targets for [P] is supported by the distribution of clearly locative marking in perfects in Celtic languages and Estonian: in the Celtic languages we find locative marking in the form of verb-adjacent particles (morphologically related to prepositions), and in Estonian we find locative (adessive) marking on the subject DP.

Chapter 4

DO-support

4.1 Introduction

Chapter 2 of this dissertation argued that auxiliary BE reflects a morphological strategy to realize inflectional features that are *stranded* by being *insufficiently local* to a main verb. As I observed in the course of that discussion, this is very much in the spirit of the Stray Affix Filter, articulated by Lasnik (1981), which bans representations in which inflectional affixes have not been (syntactically) provided with a lexical host.

This approach to auxiliary BE is potentially in conflict with previously-advanced theories of English *do*-support. It was partially to account for the distribution of *do*-support that the Stray Affix Filter was originally proposed by Lasnik: since at least Chomsky (1957) it has been proposed that *do*-support occurs as a “last resort” strategy to “rescue” affixes that are unable to combine with the main verb, a view that has remained in the mainstream of work on *do*-support (Bobaljik, 1995; Chomsky, 1991; Embick and Noyer, 2001, a.o.).

This chapter demonstrates that this conflict is only apparent, because the logic of the Stray Affix Filter is in fact *ill suited* to account for *do*-support. I argue that once we consider DO-support¹ processes in languages other than English, it becomes clear that DO is *not* generally inserted as a “last resort” means of repairing stranded inflectional information. The empirical focus of the chapter is DO-support in the Scandinavian languages (Källgren and Prince, 1989; Lødrup, 1990; Houser et al., 2006, 2010; Platzack, 2008), in the Northern Italian dialect Monnese (Benincà and Poletto, 2004), and in Breton (Jouitteau, 2005, 2010). Like English, all of these languages use DO to realize finite inflection in some syntactic environments. Unlike in English, however, all of these are languages in which we have reason

to think that T^0 would be able to establish an inflectional relationship with the verb, even in the environments of DO-support. Scandinavian shows that we find DO-support even when inflection *does* combine with the main verb, while Monnese and Breton demonstrate that DO-support occurs even when V^0 -to- T^0 movement is otherwise available. The occurrence of DO therefore cannot be attributed to the failure of T^0 and V^0 to combine.

I propose that DO, unlike BE, corresponds not to stranded inflectional features but to a syntactically distinct verbal head, which I identify with the verbalizing/eventivizing head v^0 . This follows previous work on DO-support (Embick and Noyer, 2001; Platzack, 2008, a.o.), as well as on “light verb” uses of DO that has associated it with v^0 . I argue that DO-support environments can be uniformly understood as environments in which v^0 is required to be pronounced in a position separate from its lexical verb complement: DO is the default realization of this stranded v^0 head.

The chapter begins with a brief review of the well-known facts of English *do*-support, and an overview of “last resort” analyses of the phenomenon. Section 4.3 then turns to DO-support in other languages, demonstrating that they are not compatible with the last-resort analyses that has been developed for English (Chomsky, 1957; Lasnik, 1981, 1995; Bobaljik, 1995; Embick and Noyer, 2001; Cowper, 2010). Section 4.5 argues that other approaches to DO advanced in the literature are similarly unable to account for the full cross-linguistic picture. Section 4.4 sketches an alternative approach to DO-support in which it reflects the prioritization of a T^0 - v^0 relationship over a v^0 - V^0 relationship.

4.2 English *do*-support as a “rescue” operation

English *do*-support has been discussed in the generative literature since Chomsky (1957), and has played a central role in motivating theories of English inflection, as well as approaches to “last-resort” repair strategies (Chomsky, 1957, 1991; Lasnik, 1981; Pollock, 1989; Bobaljik, 1995; Embick and Noyer, 2001, among many others).

The canonical environments of *do*-support are exemplified in (1). These include clausal negation or emphasis, V^0 -to- C^0 movement in polar questions and non-subject *Wh*-questions, VP ellipsis, and VP displacement.

¹This chapter continues the typographic convention of marking lexical items from individual languages in italics (e.g. *do*), and using the English verb in small caps to refer to equivalent verbs across languages (e.g. DO).

- (1) a. The children didn't read the book. (negation)
 b. The children DID read the book. (emphasis)
 c. Did the children read the book? (polar question)
 d. What did the children read? (non-subject *Wh*-question)
 e. These children read the book, and those ones did too. (VP ellipsis)
 f. I told them to read the book, and read the book they did. (VP displacement)

The most widely accepted view since Chomsky (1957) has held that the environments in (1) are unified by the fact that they disrupt the *Lowering* relationship between T^0 and V^0 . This disruption is due to an intervening polarity head (1a-b), to movement of T^0 itself to C^0 (1c-d), or by deletion or movement of V^0 (1e-f) (Chomsky, 1957; Jaeggli and Hyams, 1993; Bobaljik, 1995; Embick and Noyer, 2001).

This kind of approach has closely linked *do*-support to the absence of V^0 -to- T^0 movement in English. Support for this approach has been drawn from the fact that the rise of obligatory *do*-support coincided with the loss of obligatory verb movement in English (Kroch, 1985; Roberts, 1985; Han and Kroch, 2000, based on the quantitative study by Ellegård, 1953). Building on the work of Emonds (1964), Pollock (1989) similarly supposes that *do*-support is contingent on the failure of main verbs to move out of the VP in English. Within English, the link between *do*-support and the lack of movement to T^0 has been further supported by the fact that *do* is *blocked* by the occurrence of an auxiliary or modal, verbs that do appear to occur in T^0 :

- (2) a. *The children didn't will read the book. (✓ *won't*)
 b. *Did the children have read the book? (✓ *have the children...*)
 c. *The children were reading the book, and the teacher was doing too. (✓ *was too*)

Further supporting the correlation between *do*-insertion and the lack of V^0 -to- T^0 movement, there is evidence that *be* and *have* remain below T^0 in imperative clauses. In exactly this environment, they require *do* when they co-occur with negation in negative imperatives (Lasnik, 1981; Potsdam, 1998):²

- (3) a. Don't have eaten the cake before the party!

²Speakers vary on the base acceptability of imperatives with perfect *have* and progressive *be*, but all speakers who accept these examples require *do* in negative imperatives.

(cf. * *Haven't eaten the cake before the party!*)

b. Don't be late!

(cf. * *Be not late!*)

It is on the basis of these kinds of patterns that *do*-support has been regarded as motivated by “stranded” affixes in T^0 , inserted to repair an otherwise-ill-formed structure when Lowering is blocked. On such approaches, *do* is inserted directly in T^0 to provide affixes with a morphological host.

The “last resort” nature of *do*-support – the fact that it can apply only when Lowering is impossible – was captured in early accounts by its being ordered late in the derivation, after Lowering had failed to apply. For Chomsky (1957), this ordering is stipulated. Lasnik (1981) proposes that *do*-support applies after other rules because its conditioning trigger – the Stray Affix Filter – is very general, and general processes apply after more specific processes in language generally.³

Within Distributed Morphology, the late application of *do*-support has been captured by locating it in the (post-syntactic) morphological component. Halle and Marantz (1993) propose that *do* occurs to satisfy a morphological well-formedness condition of the English Tns node. If no verb is adjoined to Tns, a V node with “no features other than its category identification” (137) is inserted, and this node is realized by the “least marked” verb *do*. Bobaljik (1995) adopts a basically identical account, proposing that *do* is inserted in T^0 whenever T^0 is not morphologically adjacent to V^0 , adjacency being interrupted by an intervening subject (in subject-aux inversion), clausal negation, or the absence of V^0 under ellipsis, though not by intervening adverbs.⁴

What all of these approaches to *do*-support have in common is that they assume that *do* occurs in order to morphologically realized stranded inflectional in T^0 . They are conse-

³In recent work, Chomsky has proposed that *do*-support is a “last resort” mechanism in quite a different sense. Chomsky (1991) proposes that *do*, when it occurs, is inserted *below* T^0 , rather than as a within-derivation “repair” of stranded affixes in T^0 . The sense in which *do*-support is “last resort” is re-framed in terms of transderivational economy calculations: Chomsky proposes that this kind of insertion is somehow “costly”, and that a derivation in which it occurs will always be less economical than one with Lowering. It is only when Lowering is impossible, then, that the derivation with *do*-support will be possible.

In discussion of expletive *there* insertion, however, Chomsky (1995) suggests that comparison is possible only between derivations with *identical* numerations. Assuming that the inserted *do* constitutes a separate lexical item in the original numeration, the transderivational-economy approach to *do*-support’s “last resort” character appears insupportable.

⁴Embick and Noyer (2001) further develop an analysis of *do*-support framed in terms of structural, rather than linear, adjacency. This account is discussed in further detail in section 4.5.

quently fundamentally incompatible with the central argument of chapter 2, that auxiliary BE occurs cross-linguistically to realize stranded inflection.

With this in mind, in the next section I turn to DO-support outside English. We will see that its cross-linguistic profile is incompatible with the view that DO is inserted to support stranded inflection, in T^0 or elsewhere. This resolves the (apparent) conflict between DO-support and the analysis of BE argued for in chapter 2, in favour of the latter.

4.3 DO cross-linguistically

Much of the best-known literature on DO-support has discussed only English data (Chomsky, 1957, 1991; Pesetsky, 1989; Bobaljik, 1995; Embick and Noyer, 2001; Schütze, 2004; Bruening, 2010, among many others), perhaps creating the impression that it is a phenomenon that occurs only in English.

Contrary to this impression, however, analogues of *do*-support have been described for many languages (though it is true that none of them use DO in *exactly* the same environments as English). These languages include Breton (Jouitteau, 2005, 2010), Central and Western varieties of Basque (Rebuschi, 1983; Ortiz de Urbina, 1989; Haddican, 2007a), Catalan (Llinas i Grau, 1991), Korean (Hagstrom, 1995, 1996), Monnese (Benincà and Poletto, 2004), and the mainland Scandinavian languages (Källgren and Prince, 1989; Lødrup, 1990; Houser et al., 2006, 2010; Platzack, 2008; Ørsnes, 2011), among others.⁵

This section compares DO-support patterns found in the Scandinavian languages, Monnese, and Breton. The significance of these languages is that they each provide evidence that DO-support occurs in environments in which T^0 would otherwise be able to establish an inflectional relationship with the verb. In the mainland Scandinavian languages, DO occurs despite the availability of verb movement to a position higher than T^0 , and can even *co-occur* with a finitely inflected main verb (resulting in inflection doubling). In Monnese, meanwhile, DO-support appears to *bleed* V^0 -to- T^0 movement that would have otherwise have united the verb with finite inflection. In Breton, finally, DO arises despite the verb having moved through T^0 .

Comparison across these languages constrains the possible analyses of DO-support. The most significant point, in the wider context of this dissertation, is that DO-support cannot be

⁵All these languages require finite inflection to be expressed on DO in some syntactic environments. The list does not include languages in which DO is in free variation with a simple inflected verb.

linked specifically to the absence of V^0 -to- T^0 movement, as has been argued for English, nor can it be a last-resort process that occurs very late in the derivation, in response to stranded inflectional features. Any such approach would require DO-support to be able to “undo” prior instances of movement, particularly head movement. On the basis of the observations in this section, I argue in section 4.4 that DO-support reflects not stranded inflectional features, but rather an instance of v^0 that is required to be pronounced separately from the lexical verb.

4.3.1 Danish, Norwegian, and Swedish

This section describes patterns of DO-support in the mainland Scandinavian languages. The focus is on data from Danish, though largely parallel facts have been described for Norwegian and Swedish. Where the languages differ substantially, it is noted below.

Danish DO-support arises in a *subset* of the environments triggering English *do*-support, according to the description of Houser et al. (2006) and Houser et al. (2010). The DO verb in Danish *gøre*, which has the same lexical meaning as English *do*. As a finite auxiliary *gøre* bears finite inflection when the VP has been *displaced* or *elided*: the relevant environments are VP topicalization, VP ellipsis, and VP pronominalization. Illustrative examples are given in (4) (= Houser et al., 2006, p.1–2, ex. 6–8).

- (4) a. Jasper lovede at vaske bilen og [_{VP} vaske bilen] **gjorde**
 Jasper promise.PAST to wash car.DEF and wash car.DEF GØRE.PAST
 han (så sandelig).
 he so truly
 “Jasper promised to wash the car and wash the car, he did (indeed).”
- b. Mona vaskede ikke bilen men Jasper **gjorde**
 Mona wash.PAST not car.DEF but Jasper GØRE.PAST
 “Mona didn’t wash the car, but Jasper did.”
- c. Mona vaskede ikke bilen men det **gjorde** Jasper
 Mona wash.PAST not car.DEF but DET GØRE.PAST Jasper
 “Mona didn’t wash the car, but Jasper did (that).”

These facts are substantially similar to the English use of *do*-support in VP topicalization and VP ellipsis. Unlike English, however, Danish does *not* employ *gøre* in the context of clausal negation, emphasis, or V^0 -to- C^0 movement in questions, as illustrated by (5) (= Houser et al., 2006, p. 2, ex. 9–11).

- (5) a. Jasper vaskede ikke bilen.
 Jasper wash.PAST not car.DEF
 “Jasper didn’t wash the car.”
- b. (Jo,) Jasper vaskede faktisk bilen.
 yes Jasper wash.PAST actually car.DEF
 “Actually, Jasper did wash the car.”
- c. Vaskede Jasper bilen?
 wash.PAST Jasper car.DEF
 “Did Jasper wash the car?”

As in English, DO-support in Danish is categorical: it is obligatory in the environments of (4), and obligatorily absent elsewhere, as in (5). Danish, however, is a verb-second language in which the finite verb occupies a relatively high position: as the sentences in (5) demonstrate, the verb (obligatorily) occurs *before* negation, and is able to invert in questions. The occurrence of *gøre* in the sentences in (4) must therefore indicate that verb movement out of the VP is either *prevented* or *undone*.

Also as in English, Danish DO-support is *not* triggered in the presence of auxiliary verbs, including passive *blive* ‘become’, perfect *have* ‘have’, or modals, which are themselves stranded by both VP topicalization and VP ellipsis, as demonstrated for the modal *kunne* ‘can’ in (6):⁶

- (6) a. CONTEXT: “There are slow, empty days and what can one write about then?”
 [VP Undersøge noget] **kan** man jo altid ...
 investigate something **can** one ADV always
 “One can always investigate something” (Houser et al., 2006, 5, ex. 23a)
- b. Jeg har prøvet at male det [...] men jeg **kan** ikke.
 I have tried to paint it but I **can** not
 “I have tried to paint it...but I can’t.” (Houser et al., 2006, 7, ex. 28a)

Houser et al. (2006) report that VP topicalization is limited to matrix clauses (or to verb-second embedded clauses). VP ellipsis and pronominalization, however, are both possible in embedded contexts, and are interesting for insight they provide into the *position* of *gøre* in Danish. In non-verb-second contexts, the main verb in Danish occurs *after* negation and VP-level adverbs, which has been taken as evidence that the verb remains within the VP.

If *gøre* were merged to T⁰ prevent finite affixes from being stranded, we would therefore

⁶Houser et al. (2006) obtain these examples from corpora.

expect its position to *contrast* with that of main verbs in embedded contexts. Instead, *gøre* occurs *after* negation and VP adverbs in embedded clauses, just as main verbs do:⁷

- (7) At antyde at truslerne eksisterer,
to suggest that threats.DEF exist
- a. når de rent faktisk ikke **gør** _–, vil...
when they purely factually not **do.PRES**, will...
- b. *når de **gør** rent faktisk ikke \hat{T} , vil...
when they **do.PRES** purely factually not will...
- c. når de rent faktisk ikke **eksisterer**, vil...
when they purely factually not exist will...
- d. når de rent faktisk ikke **har** eksisteret i flere år, vil...
when they purely factually not have existed in several years will
“To suggest that the threats exist, when they in fact don’t, will...”
- (Houser et al., 2006, 16–17, ex. 47)

As observed by Platzack (2008) and Houser et al. (2010), that these facts argue strongly that *gøre* is merged *lower* than T^0 (and perhaps that English *do* is as well), against the common view that support DO is merged directly to T^0 as a last-resort repair.⁸

The facts in Norwegian, as described by Lødrup (1990), and in Swedish, as described by Källgren and Prince (1989) and Platzack (2008), are substantially parallel to the facts just described for Danish. A brief review is provided here.

In Norwegian the inserted verb in Norwegian is *gjøre*, cognate of *gøre*, and its use in VP

⁷The low position of *gøre* is further supported by the fact that it can optionally occur below other auxiliaries, as in (i) (=Houser et al., 2010, p. 9, ex. 9), where *gøre* takes a participial form under perfect *have*.

- (i) Hun [dukkede op] ligeså uanmeldt, som han selv ofte havde gjort det.
she emerge.PAST up as unannounced as he self often have.PAST do.PTCP DET
“She emerged as unannounced as he himself had often done.”

An extended discussion of non-finite *gøre* appears in Ørsnes (2011). The example in (i) resembles the fact that English *do* can occur under perfect *have* in certain varieties of British English (Thoms, 2010, 16, ex. 25):

- (ii) a. Rab might bribe Bill, and Morag might do, too.
b. Rab might have bribed Bill, and Morag might have done, too.

Authors have disagreed regarding whether (ii) should be analyzed together with DO-support more generally, and whether it provides evidence for a low position of *do* in English (Haddican, 2007b; Baltin, 2010; Thoms, 2010).

⁸In spite of the data in (7), Houser et al. (2006) maintain that *gøre* is merged directly to T^0 , and do not provide any explanation of embedded word orders in Danish.

topicalization is illustrated in (8):

- (8) Spille golf gjør jeg aldr
play.INF gold do.PRES I never
“Play golf I never do.” (Lødrup, 1990, 3, ex. 1)

Lødrup observes that sentences such as (8) alternate with sentences such as (9), in which *both* *gjøre* and the main verb show finite inflection, though apparently this option is dispreferred by speakers:⁹

- (9) Spiller golf gjør jeg aldr
play.PRES gold do.PRES I never
“Play golf I never do.” (Lødrup, 1990, 3, ex. 1)

In Swedish, by contrast, “doubled” finite inflection as in (9) is *required* (Källgren and Prince, 1989; Platzack, 2008).¹⁰ The cognate of *do/gøre/gjøre* in Swedish is *göra*. It occurs in VP topicalization as in (10) and VP pronominalization as in (11). VP ellipsis is unavailable in Swedish, as indicated by the non-omissability of *det* in (11).

- (10) och körde / *köra bilen gjorde han.
and drive.PAST / *drive car.DEF do.PAST he
“...and drive the car he did.” (Platzack, 2008, 1, 5b)

- (11) Maria körde inte bilen men Johan gjorde *(det).
Mary drive.PAST not car.DEF but Johan do.PAST it
“Mary didn’t drive the car but Johan did.” (Platzack, 2008, 2, ex. 7a)

As in the case of Danish, DO-support in Norwegian and Swedish shows a somewhat surprising interaction with V⁰-to-T⁰ movement. In all of these languages, we might have expected verb movement in matrix clauses to *bleed* DO-support in these languages; an interesting comparison in this respect is so-called “V⁰-stranding VP ellipsis”, where V⁰-to-T⁰ movement has been argued to allow the main verb to *escape* the ellipsis site (Doron, 1999; McCloskey, 1991; Goldberg, 2005, a.o.). The question arises of why verb movement does not similarly bleed ellipsis or topicalization of VP in the mainland Scandinavian languages.¹¹

⁹Lødrup claims this construction with finite inflection is also available in Danish, though similarly dispreferred. The availability of doubled inflection in Danish is confirmed by Houser et al. (2006, 2010).

¹⁰Platzack (2008) observes that Swedish has been claimed to have the option of using the main verb in its non-finite form, but reports that he and other Swedish speakers find that option ungrammatical.

¹¹Houser et al. (2006) suggest that head movement is *differently timed* in Scandinavian languages, com-

Given that the Scandinavian languages lack independent V^0 -to- T^0 movement – the verb moves all the way to C^0 in matrix clauses, but remains *in situ* in embedded clauses – we might hypothesize, however, that the VP is moved or elided before the verb moved out of the VP, i.e. before the merger of C^0 .

It is nonetheless clear that DO is not merged directly to T^0 in these languages, as is clear from its position *after* negation in embedded clauses. This was shown for Danish above, and is demonstrated for Swedish in (12).

- (12) Maria gillar mjölk medan Johan inte **gör** det.
 Mary like.PRES milk while Johan not **do.PRES** it
 “Mary likes milk while Johan does not.” (Platzack, 2008, 4, ex. 11b)

If *göra* (=DO) were inserted in (12) to directly support T^0 , it should occur to the *left* of negation. Instead it occurs in the position that would be occupied by the finite verb in the absence of ellipsis. Together with the fact that DO can occur below other auxiliary verbs, this motivates both Platzack (2008) and Houser et al. (2010) to conclude that DO-support in Scandinavian languages does *not* occur in T^0 , but instead in a lower position.

Finally, the fact that doubled inflection is available in these languages, and obligatory in Swedish, is especially striking, as it demonstrates that DO-support in these languages does *not* reflect the inability of T^0 to establish some kind of inflectional relationship with the main verb.

In summary, DO-support in Scandinavian, though resembling *do*-insertion in English, casts doubt on the view that DO is merged to support an instance of T^0 that has been unable to establish an inflectional relationship with the lexical verb. In the next section we see that the same is true of DO-support in Monnese, where DO-support appears to “undo” V^0 -to- T^0 movement.

4.3.2 Monnese

Monnese is a Lombardian dialect of Northern Italy, whose DO-support pattern is described by Benincà and Poletto (2004). Like the Scandinavian languages, Monnese is a language with DO-support despite the general availability of verb movement to a high clausal position.

The inserted verb in Monnese is *fa*; as a main verb its uses are parallel to *do/gøre/gjøre/göra*.

 pared with languages with V^0 -stranding ellipsis.

The environments in which *fa* is inserted are again a subset of those triggering *do*-support in English, though a different subset than seen in the Scandinavian languages: *fa* occurs in matrix interrogatives in Monnese, in clauses that lack a finite auxiliary or modal, undergoing V⁰-to-C⁰ movement in place of the finite verb. As (13) demonstrates, the main verb occurs in a non-finite form.

- (13) a. *fa-l majà?*
 does-he eat?
 “Does he eat?”
- b. *ke fa-l majà?*
 what does-he eat?
 “What does he eat?”
- c. *à-l majà?*
 has-he eaten?
 “Has he eaten?”
- d. *ke à-l majà?*
 what has-he eaten?
 “What has he eaten?”

(Benincà and Poletto, 2004, 52, ex. 1a-b,e-f)

Benincà and Poletto demonstrate that verb movement to C⁰ can be detected in these examples by the inversion of the subject clitic and the auxiliary. Monnese is a language with a system of subject proclitics in ordinary declarative clauses; these appear as *enclitics* in matrix interrogatives (Benincà and Poletto, 2004, p. 62).

As in other languages, the auxiliary verbs BE and HAVE do *not* trigger DO-support, but are able to invert with the subject.¹²

As Benincà and Poletto observe, *fa*-insertion in Monnese is particularly interesting for its interaction with V⁰-to-T⁰ movement. Like other Romance languages, Monnese shows evidence that main verbs move out of the VP in declaratives: finite verbs occur before the adverbs used by Pollock (1989) to diagnose verb movement in French, as well as before the marker of sentential negation *mìa*:

¹²As in varieties of British English, this is also true not only of BE in its “main verb” use, but also of “main verb” HAVE. Benincà and Poletto report that other auxiliaries and modal verbs (syntactically main verbs in Monnese, as in other Romance varieties) show mixed behaviour: *olé* ‘want/wish’ and *vej da* ‘have to’ can move to C⁰ and consequently never trigger DO-support; *podé* and *rüà-j*, both meaning ‘can/may’, never move to C⁰ and so both require DO-support; and two other verbs, *nda* ‘go’ and *fa* ‘do’ show mixed behaviour and optionally trigger DO-support (Benincà and Poletto, 2004, 72-3). These facts can be seen as related to the variation in “main verb” HAVE’s behaviour across dialects of English.

- (14) a. l tSàkola semper
 he speaks always
 “He always speaks.”
- b. l ñarèl l parla zà
 the baby he speaks already
 “The baby already talks.”
- c. l va maj
 he goes never
 “He never goes.”
- d. l tSàkola mìà
 he speaks not
 “He does not speak..” (Benincà and Poletto, 2004, 59-60, ex. 7a,c,e, 8)

If *both* auxiliaries and main verbs occupy T^0 in Monnese, the question arises of why one, but not the other, accompanies T^0 onwards to C^0 in questions.¹³

Furthermore, Benincà and Poletto point out that even if main verbs are idiosyncratically unable to raise from T^0 to C^0 , it cannot be the case that *fa* is merged directly in C^0 to support some stranded interrogative features. If this were the case, we would expect V^0 itself to nonetheless raise as far as T^0 , leaving *fa* to originate in C^0 , *above* the position of finite inflection. That this is not the case is shown by the ungrammaticality of examples such as (15a), which would be analogous to the English question in (15b):

- (15) a. *Fà t cumpret?
 do_{root} you buy.2SG
 “Do you buy?”
- b. *Do he buys? (Benincà and Poletto, 2004, 85-6, ex. 35)

This would also not explain the fact that the main verb reverts to a position *below* negation when DO-support has occurred, in contrast to (14):

- (16) a. Fe-t to-la o fe-t mìà to-la?
 do.you take.it or do-you not take.it
 “Do you take it or do you not take it?”
- b. Fe-t mìà majal ’l pom?
 do-you not eat.INF the apple?

¹³One possibility is that auxiliary verbs actually move to a *slightly* higher head in finite declarative clauses, though both move before negation and clausal adverbs. This would not resolve the further issues pointed out immediately below, namely that inverted *fa* bears finite inflection while the main verb reverts to the low clausal position belonging to infinitive verbs, “undoing” V^0 -to- T^0 movement.

“Do you not eat the apple?”

(Cecilia Poletto, p.c.)

The ungrammaticality of (15a), together with (16), indicates that, in environments of V^0 -to- C^0 movement, the main verb is *prevented* from combining with finite inflection in T^0 ; *fa* must be inserted no higher than the position of finite inflection (here assumed to be T^0) and subsequently move to C^0 .

In summary, Monnese appears to allow DO-support to *bleed* verb movement to T^0 in environments that would otherwise permit it. Like the Scandinavian languages, it demonstrates that DO-support must be motivated by something other than

4.3.3 Breton

Breton, as described by Joutteau (2010), exhibits a pattern of DO-support similar to the cases we have seen so far: in certain syntactic environments finite inflection is realized on a verb equivalent to English *do*, which does not itself contribute to the semantic interpretation of the clause.

Breton is language with V2 word-order Joutteau (2005).¹⁴ As in other V2 languages, in finite clauses the finite verb must be preceded by another constituent; this constituent receives a topicalized interpretation. This is illustrated in (17) (=Joutteau, 2010, 4, ex. 14b):¹⁵

- (17) [D' ar jardin] ez an _ .
P DET garden R go.1SG
“I am going INTO THE GARDEN.”

Breton differs from other V2 languages, however, in its default strategy for filling the pre-verbal position. In the Germanic languages, for example, this position is filled by the subject in information-structure-neutral contexts. In Breton, by contrast, such clauses provide the context for DO-support: the pre-finite position is occupied by a non-finite form of the main verb, while tense and agreement inflection occurs on the "dummy" verb *ober* (=do) in the canonical “second” position. This is exemplified by (18) (=Joutteau, 2010, 4, ex. 10a'). In contrast to (17), Joutteau reports that (18) communicates a neutral information-structure.

¹⁴Joutteau (2005) argues that Breton is a “linear” V2 language, in the sense that the verb must be preceded by some constituent, but that constituent can occur in any of a number of left-peripheral positions.

¹⁵The finite verb itself is always preceded by a pre-verbal particle glossed as R (the ‘*rannig-verb*'). This is analyzed by Joutteau (2005) as expressing a *finiteness head* above T^0 .

- (18) a'. Mont a ran d' ar jardin.
 go.INF R do.1SG P DET garden
 "I am going into the garden."

Jouitteau (2005, 2010) proposes that the non-finite clause-initial verb in (18) is generated by *excorporation* V^0 from T^0 (contra restrictions on excorporation proposed by Baker (1988)), to satisfy Breton's V2 requirement as a last-resort operation. Jouitteau (2010) argues against the view that sentences like (18) involve VP topicalization (analogous to that seen in above for the Scandinavian languages), on the grounds that the fronted verb is not interpreted as a topicalized or focused element.¹⁶

Neither auxiliary nor main verb BE (*bezañ/bout*, nor compound verbs formed from it, permit *ober*-support in Breton, but it is otherwise fully productive (Jouitteau, 2010, 7).¹⁷

If Jouitteau is correct that *ober* insertion occurs *despite* verb movement to T^0 , then Breton in a sense provides a mirror-image of *fa*-insertion in Monnese. In Monnese, finite inflection moves to C^0 to satisfy the requirements on question formation, apparently stranding V^0 . In Breton, by contrast, it is V^0 that moves into the left periphery, apparently stranding finite inflection, which must itself remain *in situ* in order to satisfy the verb-second requirements of the language.

Alternatively, even if we do not adopt Jouitteau's analysis of infinitival fronting in Breton as a case of excorporation, but instead assume that it involves some form of V(P)-topicalization, *ober*-support in Breton must *prevent* or *undo* verb movement to T^0 in order to allow it to move to the pre-tense position, satisfying V2. This has been a recurring theme of DO-support phenomena across the languages discussed here.

¹⁶In support of the view that sentences such as (18) do not involve V- or VP-topicalization, Jouitteau shows that *ober*-support contrasts with a (lexically restricted) process of verb *doubling*, illustrated by (i):

- (i) Redek a redan bemdez
 run.INF R run.1SG every.day
 "I run every day." (Jouitteau, 2010, 12, ex. 42)

For verbs that also allow *ober*-support, verb doubling *contrasts* with *ober*-support in being associated with a hard-to-define focus-like information structure (Jouitteau, 2010, 14-15).

¹⁷Jouitteau observes, however, that though the verb BE cannot trigger *ober*-support, it does allow verb doubling *without* the special information structure otherwise conveyed by verb doubling. This appears to also be the case for those dialects of Breton that *lack* *ober*-support altogether.

4.3.4 Summary: a (partial) cross-linguistic profile of *Do*-support

The previous four sections have reviewed DO-support phenomena in English, the mainland Scandinavian languages, the Northern Italian dialect Monnese, and Breton. In all of these languages, finite inflection is realized on DO in environments where there is reason to believe that a relationship between T^0 and the main verb is disrupted. In all these languages auxiliary verbs prevent DO-support from being necessary (with exceptions such as *do*-support in English imperatives), while in dialects of both English and Danish DO is sometimes available in the *complement* of auxiliaries (i.e. in cases of ellipsis).

What these languages do *not* present, at least at first glance, is a unified context in which DO-support is triggered. That is, the sense in which the relationship between T^0 and the main verb is “disrupted” remains opaque.

As mentioned in the introduction to this section, however, they do demonstrate that DO-support cannot be a derivationally last-resort mechanism, which occurs to repair structures in violation of something like the Stray Affix Filter. The reason for this is that all the languages discussed in this section provide evidence that V^0 and T^0 should be able to establish an inflectional relationship in the environments of DO-support: if the *sole motivation* for DO-support is the “stranding” of inflection in T^0 , V^0 -to- T^0 movement, or any other inflectional relationship between T^0 and V^0 , should bleed DO-support. Applying a last-resort logic to DO-support thus requires either that V^0 -to- T^0 movement can be entirely “undone” late in the derivation, should it prove inconvenient, or that a form of “look ahead” prevents such movement from taking place in certain clauses.

We saw in Danish, for example, that the DO verb *gøre* occurs when the VP is elided or topicalized. As a verb-second language, however, Danish exhibits verb movement to a relatively high clausal position, certainly to a position outside the main VP. We would therefore expect V^0 to escape the VP prior to the latter being moved or elided: as was mentioned in section 4.3.1, verb movement to T^0 has been argued to have exactly this effect in languages with verb-stranding VP ellipsis (Doron, 1999; McCloskey, 1991; Goldberg, 2005).

Houser et al. (2006) propose that the failure of head movement to escape VP ellipsis or topicalization in Danish may be due to the *timing* of head movement in the language, adopting Chomsky’s (2000) proposal that head movement, unlike phrasal movement, occurs

at PF. They acknowledge, however, that this raises the the question of why Danish differs from languages in which verb movement is timed *before* topicalization or ellipsis: the timing of head movement in the derivation is not an appealing point for parametric variation.

Besides this, however, such an account cannot carry over to Monnese, where verb movement to T^0 unexpectedly fails to feed movement from T^0 to C^0 . As Benincà and Poletto (2004) show, main verbs in Monnese raise as far as T^0 , but cannot move onwards to C^0 . Here a solution cannot be found in the relative timing of head movement, as V^0 -to- T^0 and V^0 -to- C^0 movement are *both* instances of head movement, and so would necessarily occur within the same module.

The timing issue is still more problematic in Monnese, however, as discussed in section 4.3.2. If DO were merged to fulfill a requirement of C^0 , in the absence of grammatical V^0 -to- C^0 movement, then we might expect a *non-finite* form of DO to occur. Instead, however, Monnese *fa* is inflected for the tense and agreement features associated with T^0 , while the main verb reverts to the low clausal position associated with infinitive verbs. On standard approaches to DO-support, this seems to force us to one of two undesirable conclusions: either V^0 -to- T^0 movement can be “undone” after C^0 is merged, to avoid illicit movement of V^0 all the way to C^0 , or there is “look ahead” in the derivation, so that V^0 -to- T^0 movement is conditioned by whether V^0 -to- C^0 movement would subsequently be required.

A similar point is made by the facts from Breton. Jouisseau (2005, 2010) demonstrates that an infinitival verb occurs in sentence-initial position (leaving inflection to be realized on T^0) as a “last-resort” operation used to fulfill the requirement for verb-second word order. If DO-support arises due to a failure of V^0 -to- T^0 movement, however, then again this movement would have to be “undone”, or the derivation would need to precognitively avoid this otherwise-mandatory instance of movement.

To summarize, these languages all appear to argue against the view that DO-support is a last-resort insertion process.¹⁸ If DO were *inserted* or *selected* in these languages, this insertion would have to be performed before there were any need for DO to occur – i.e. before V^0 -to- T^0 movement took place. Other analyses of DO-support that have been advanced on the basis of the English facts similarly fail to extend to these languages in which DO-support seems to bleed V^0 -to- T^0 movement (rather than the other way around). I turn to a more

¹⁸To my knowledge, this conclusion is not contradicted by DO-support processes in any of the other languages listed at the beginning of this section.

thorough summary of these failures in section 4.5, before sketching a more successful analysis in section 4.4.

4.4 Towards a theory of DO-support

As seen so far in this chapter, the analysis of DO-support as a last-resort insertion process, triggered by the failure of the syntactic component to provide affixes in T^0 with a lexical host, encounters significant problems once we look beyond the core distribution of *do*-support in standard varieties of English. This resolves the apparent conflict identified at the beginning of this chapter, between DO-support and the analysis of auxiliary BE proposed in chapter 2.

This leaves the question, however, of how DO-support *should* be analyzed. This section sketches an approach consistent both with the general framework of verbal inflection developed in this dissertation, and with the cross-linguistic profile of DO-support described above in section 4.3. I propose that rather than DO occurring to repair a T^0 that was *unable* to establish an inflectional relationship with the main verb, the occurrence of DO (instead of BE) instead crucially *depends* on T^0 having established a relationship with a verbal head.

More specifically, I propose that DO corresponds to an instance of v^0 that is not spelled out together with a lexical verb. This reflects the view that “main verb” DO, in its uses as a light verb, is similarly a realization of v^0 that does not contain a distinct lexical root, a view previously applied to DO-support by a number of authors (Embick and Noyer, 2001; Hagstrom, 1996, 1995; Haddican, 2007a; Platzack, 2008). This *unifies* support and light verb uses of DO. This approach suggests that the task of analyzing DO-support is to explain why the main verb and v^0 are pronounced separately from one another in exactly the environments of DO-support.

I suggest in this section that DO-support generally reflects a *conflict* on two requirements on the position in which v^0 is realized. On the one hand, I propose, there is a condition imposed by T^0 requiring v^0 to remain in some particular relationship with it. On the other hand, there are conditions on the realization of the main verb itself, which may conflict with this required relationship between v^0 and T^0 .

A possible response to this conflict, I propose, is to pronounce v^0 and V^0 in separate positions, resulting in DO-support. Another possible response, I will suggest, is *verb doubling*,

which we see across languages in some of the same environments that trigger the DO-support processes discussed here.

Let us begin by considering the nature of the linearization requirement imposed by T^0 . In their discussion of DO-support in English, Embick and Noyer argue that the occurrence of DO reflects the locality requirement articulated in (19):

- (19) T^0 must be in an immediately local relationship with v^0 . (Embick and Noyer, 2001, 586, ex. 74)

“Immediately local” means that T^0 must either have a vP complement or must be contained within the same head as v^0 . Whenever the relationship of immediate locality between T^0 and v^0 is disrupted, by an intervenor such as negation, or by movement of T^0 (to C^0) or vP (in topicalization), an expletive v^0 is merged directly to T^0 , resulting in the appearance of DO.

In order to account for the fact that auxiliary verbs and modals do not trigger DO-support, however, Embick and Noyer are forced to propose that *be* and *have*, and the modal auxiliaries, are all instances of v^0 . Besides being difficult to justify on independent grounds, this is clearly incompatible with the proposals of chapters 2 and 3, which argued against the identification of auxiliary verbs with dedicated syntactic verbal heads.

What does unify HAVE and BE with v^0 in finite contexts, however, is that all are in an inflectional Agree relationship with T^0 . I therefore propose that we should adapt Embick and Noyer’s proposal in (19), reformulating it as a locality requirement between T^0 and a head with which it Agrees, as in (20):

- (20) T^0 must be immediately local to any inflectional head X^0 with which it has an Agree relationship.

In structures in which auxiliaries occur, the condition in (20) does not impose any requirement on v^0 , because T^0 Agrees with (and has its inflectional features stranded in) higher inflectional functional heads. When T^0 Agrees directly with the verb – or rather, with v^0 – (20) will impose a requirement on the position in which v^0 occurs.¹⁹

¹⁹It is, of course, possible that heads other than T^0 could impose locality requirements on the head with which they Agree. For example, we might propose to account for the occurrence of DO under other auxiliaries, in the Scandinavian languages and in varieties of British English, as resulting from Perf^0 or

As stated above, it is only when this condition is in conflict with another principle that we would expect v^0 and V^0 to be pronounced in different positions.

The example of Breton provides a relatively straightforward example of this, if we accept Joutteau's analysis of the facts. Joutteau proposes that the last-resort mechanism for satisfying verb-second in Breton involves attracting the closest non-tense element to the pre-tense position. This forces *excorporation* of V^0 from T^0 . A condition such as (20), requiring that T^0 remain adjacent to a head with which it has Agreed, would prevent v^0 itself from excorporating together with the main verb; the requirements of V2, by contrast, require that the verb itself be pronounced clause-initially. This results in a separation of v^0 from V^0 , and the default light verb DO being inserted in T^0 .

The nature of the conflicting requirement on V^0 's position is somewhat more obscure in the other languages discussed in this chapter. At the most general level, we might say that the main verb in all of these languages is required to maintain some relationship with its base position within the VP:

(21) V^0 must remain in some relation \mathfrak{R} with the VP it heads:

In English we might say that the main verb must actually remain in its base position; in Monnese it appears to be able to move no further away than T^0 ; in Scandinavian, it must undergo displacement (movement or ellipsis) together with the VP. For reference, we can state these conditions in (22):

- (22) a. Scandinavian: \mathfrak{R} = if VP is displaced (by movement or ellipsis), V^0 must likewise be displaced.
 b. Monnese: \mathfrak{R} = within the same phase (no movement to C^0)
 c. English: \mathfrak{R} = structurally adjacent (no movement beyond v^0)

The environments of DO-support are those in which the required local relationship between v^0 and T^0 is in conflict with these requirements on the main verb, *so long as v^0 and V^0 are pronounced together*. The core of this proposal is that DO-support resolves this conflict by sacrificing the unity of v^0 and V^0 , resulting in v^0 being pronounced as a default DO.

another functional head imposing a locality requirement on $[^0 v]$ much like the one imposed by T^0 .

As suggested above, another possible response would be to pronounce the verb in two positions. This has been proposed as the analysis of *verb doubling* phenomena in a number of languages.

Such analyses are framed within the copy theory of movement (Chomsky, 1993, et seq.). The copy theory of movement suggests that movement results in the moved element being doubled, and occurring in two separate syntactic positions: the appearance of movement is the result of a *morphophonological* choice to spell out the *higher* instance of a moved element, a decision made at the point of linearization.

Landau (2006) applies this to verb doubling in Hebrew V(P) topicalization, illustrated in (23). Hebrew is a language with V⁰-to-T⁰ movement, but in V(P) topicalization the fronted VP contains a non-finite form of the lexical verb, while the same verb bears finite inflection in the main clause. Landau proposes that this lexical doubling results from two separate spell-out requirements *overriding* the generalization that only one member of a movement chain being overtly realized:

- (23) a. lirkod, Gil lo yirkod ba-xayim.
 INF-dance Gil not FUT-dance in-the-life
 “As for dancing, Gil will never dance.”
- b. liknot et ha-praxim, hi kanta.
 INF-buy ACC the-flowers she buy.PAST
 “As for buying the flowers, she bought.”
- c. liknot, hi kanta et ha-praxim.
 INF-buy she buy.PAST ACC the-flowers
 “As for buying, she bought the flowers.” (Landau, 2006, 37, ex. 7, 8ab)

Landau observes that verb doubling in topicalization constructions also occurs in Haitian, Vata, Yoruba, Korean, Brazilian Portuguese, Yiddish, and Russian (Landau, 2006, 37, fn 7).²⁰ An example from Yiddish is given in (24):

- (24) a. leynen leyent er dos bukh yetst
 read-INF reads he the book now
 “As for reading, he’s reading the book now.” (Källgren and Prince, 1989, ex. 2b)

²⁰Jouitteau (2010) also mentions verb doubling structures Gungbe, Yoruba, and Spanish. Peterson (2001) describe a particularly interesting set of verb-doubling environments across the Nakh-Dagestanian languages, where verb doubling appears to be triggered to provide pre-verbal enclitics with a morphologically appropriate host.

- b. veys-n veys-t er gornit
 know-INFknow3SG he nothing
 “As for knowing, he knows nothing.” (Källgren and Prince, 1989, ex. 15a)

Because these languages pronounce the verb in two positions, it is clear that movement of the verb out of VP has not been “undone”, merely supplemented by a second copy of the verb. I suggest that these verb doubling structures result from the same *syntax* as DO-support in VP topicalization.²¹

In support of this parallel, recall that in the Scandinavian languages exhibit a different form of “doubling” in VP topicalization constructions: instead of doubling the verb, however, they allow (or, in Swedish, require) inflection to be expressed on both DO and the lexical verb:

- (25) och körde / *köra bilen gjorde han.
 and drive.PAST / *drive car.DEF do.PAST he
 “. . . and drive the car he did.” (Swedish, Platzack, 2008, 1, 5b)

As mentioned several times above, the Scandinavian inflection doubling cases illustrate very clearly that DO does not occur simply because the inflectional features of T^0 cannot find a host on V^0 .

What I would like to suggest is that verb doubling and DO-support represent two different responses to the conflict between the requirement of T^0 that it remain local to the head with which it Agrees (v^0 , in the contexts of DO-support), and a requirement of V^0 that it remain associated with its base position.

In verb doubling languages, the solution is to pronounce both v^0 and V^0 in two positions, preserving their association with one another at the *expense* of pronouncing more than one copy of both those heads. In DO-support languages, the solution is to pronounce v^0 in the position required by T^0 , but V^0 in its base position within the VP, satisfying the two conflicting requirements instead at the expense of the association between v^0 and V^0 . Keeping the verb doubling facts in mind, the DO-support facts basically involve pronouncing V^0 alone in the *tail*, rather than the head, of its movement chain, within the VP, leaving v^0 to be pronounced alone, or at the head of its own movement chain (in languages with further

²¹Trinh (2011) argues that the availability of verb doubling is the result of the basic word order (head final vs. head initial) of a language, together with a condition on copy deletion (the Edge Condition on Copy Deletion). In this case, DO-support can be understood as a resolution of conflicting requirements of T^0 and V^0 in the *absence* of the availability of verb doubling.

verb movement). The default realization of an independent v^0 , without lexical content, is the light verb DO, and so we get DO-support.²²

There remains a question regarding a language such as Monnese, however. As we have seen, DO-support in Monnese is triggered by the inability of the verb to be realized higher than T^0 . We have also seen, however, that when T^0 moves to C^0 in Monnese, and DO-support applies, it is not simply the case that the non-finite verb remains in T^0 . Instead it occurs in the lower clausal position characteristic of infinitive verbs, below negation. The relevant example is repeated in (26) from (26):

- (26) a. Fe-t to-la o fe-t mia to-la?
do.you take.it or do-you not take.it
“Do you take it or do you not take it?”
- b. Fe-t mia majal 'l pom?
do-you not eat.INF the apple?
“Do you not eat the apple?” (Cecilia Poletto, p.c.)

In addition to saying that the v^0 is pronounced separately from V^0 in Monnese, therefore, we have to explain why the result of this is not the infinitival verb remaining in T^0 .

I propose that if a head X^0 moves as far as another head Y^0 , but does *not* move together with Y^0 to a further position Z^0 , then X^0 will not be pronounced in the *head* of its movement chain but in its *tail*. As a result, a condition that prevents V^0 from being realized in C^0 would result in its being pronounced in its base position. The adjacency requirement on T^0 , however, requires that the functional head with which it Agreed remain adjacent to it, preventing v^0 from similarly lowering, to remain together with V^0 . Thus we have v^0 pronounced independently, again as the default light verb DO.

The nature of the locality requirements enforced by T^0 and V^0 has received only an initial cursory treatment in this section, and deserves a great deal of further attention. Most problematic is the nature of the locality requirement between V^0 and its base position: in particular, in both English and Monnese there appears to be a restriction on moving the verb more than a certain arbitrary distance from the VP. It remains unclear what the nature of this restriction is, exactly.

One possibility is presented by Richards (in prep.), who articulates a framework of

²²In principle, V^0 -stranding VP ellipsis could also be a case of “doubling”, only one in which the lower copy is elided with the VP. At least two languages with V^0 -stranding VP ellipsis – Brazillian Portuguese and Hebrew – also have verb doubling.

syntactic movement couched in terms of *prosodic contiguity* relationships. Developing previous work on *Wh*-movement (Richards, 2010), Richards claims that all syntactic movement is constrained by two types of contiguity requirements: two syntactic elements must be prosodically contiguous if they *Agree*, or if they are in a *selectional* relationship. The range of movement permitted and required by this system is determined by the ways in which a language projects prosodic phrase boundaries.

Agree-based contiguity could provide a natural way in which to express the requirement that T^0 remain in a local relationship with the head with which it Agrees. Selectional contiguity, by contrast, might provide a means of explaining why V^0 itself can move a certain distance from its thematic position within the VP, but not further.

4.5 Previous analyses of DO

In the previous section I outlined a view of DO-support according to which DO results from a conflict in locality requirements that forces v^0 to be realized in a separate position from the main verb. One advantage of such an approach is that it accords with the evidence that DO is, or can be, associated with a low clausal position. As we saw in embedded clauses in Scandinavian, for example, DO occurs below adverbs and clausal negation. Similarly, in Scandinavian and in varieties of British English, DO can occur *below* other auxiliaries. Finally, in the context of constituent negation in English, DO occurs below the clausal adverbs, as shown in (27):

(27) They always don't go. (Don't they?)²³

²³Tag questions like the one in (27) must in general reverse the polarity of the clauses to which they are appended, as in (i):

- (i) a. They always go, don't they?
- b. They don't always go, do they?

The fact that (27) involves constituent (non-polarity) negation is thus confirmed by the fact that must take a negative tag question.

It should be noted that previous authors have claimed that DO-support is incompatible with constituent negation. Embick and Noyer (2001), attributing the observation to Tony Kroch, claim that the incompatibility of DO-support with clausal negation argues in favour of their distributed analysis of DO-support: they propose that DO is required whenever T^0 is prevented from lowering to V^0 , as it is by both constituent and clausal negation, but that only clausal negation creates the structural context in which an expletive v^0 is actually merged to T^0 . The availability of *low* DO-support with constituent negation, however, contradicts the empirical basis of this claim.

Often for the reason that DO can be associated with low clausal positions, several other authors have proposed that DO is the overt counterpart of v^0 . What these accounts have lacked is an explanation for why v^0 and V^0 are pronounced separately in exactly the environments of DO-support.

Discussing DO-support in the Scandinavian languages, Platzack (2008) proposes that DO does not correspond to an *additional* v^0 head, but instead to the same v^0 projected in clauses without DO-support. He proposes that DO-support arises when v^0 and the main verb (the lexical root) are not combined via head movement. If DO corresponds to the relatively low head v^0 , this accounts both for the fact that it bleeds V^0 -to- T^0 movement (assuming the Head Movement Constraint, Travis, 1984), and for the fact that DO occurs after negation in embedded clauses in Scandinavian languages. It is unclear from Platzack’s discussion, however, why DO-support would be *required* in the environments in which it occurs.²⁴

Houser et al. (2010) make a proposal similar to Platzack’s, but propose that DO occurs not in v^0 but instead in a low Aux^0 position. Adopting a pronominal resumption analysis of both VP topicalization and of ellipsis, they propose that the distribution of DO in the Scandinavian languages, particularly Danish, results from the fact that auxiliary DO subcategorizes for a *pronominal* VP.²⁵

Houser et al.’s analysis resembles a proposal by Haddican (2007a) regarding DO-support in Basque and Korean. Both these languages employ DO-support in *verb focus* constructions: Haddican proposes that the lexical verb in these languages must be *nominalized* in order to be focused, and that DO realizes v^0 in the presence of a nominalized verb.

The proposal that DO selects a nominal or pronominal complement, however, faces immediate challenges. Within the Scandinavian languages, it is unclear that the approach of

²⁴The view that DO corresponds to v^0 is also advanced by Baltin (2010), in the context of the British English use of *do* below other auxiliaries in VP ellipsis.

²⁵The view that DO corresponds to a low auxiliary is also formulated by Roberts (1998). Bruening (2010), developing proposals of Baker (1991), advances a somewhat similar proposal for English, arguing that *do* occupies something analogous to a low auxiliary position. Bruening’s analysis, however, frames *do*-support as an irreducibly language-particular grammatical process. He begins with the observation that the same environments that trigger *do*-support in English are also incompatible with locative inversion, regardless of whether *do*-support actually applies: locative inversion is incompatible with clausal negation, V^0 -to- C^0 movement, etc., even in the presence of a non-*do* auxiliary verb. On the basis of this incompatibility, Bruening argues that there must be some syntactic property or features that unifies the environments in which *Do*-support applies, which also unifies the environments from which locative inversion is banned.

He proposes that this unifying property is that these environments all subcategorize for “special purpose” ([SP]) VPs, a concept adopted from Baker (1991). The [SP] equivalent of a VP containing a modal or auxiliary is simply identical to the non-[SP] VP, while the [SP] equivalent of a VP *without* a modal or auxiliary must be headed by *do*; in effect, *do* is a last-resort mechanism for creating an [SP] VP.

Houser et al. can account for cases of inflection *doubling*, obligatory in Swedish and optional (though dispreferred) in the other languages, which seem to require that the displaced VP *originate* in the complement of T^0 , from which position V^0 can establish an inflectional relationship with T^0 .

In languages such as English, Monnese, and Breton, moreover, there is no evidence in favour of the view that V^0 is prevented from combining with v^0 because it has been *nominalized*.

A different kind of analysis that nonetheless hinges on a low origin for DO is the analysis of Chomsky (1991), which is somewhat ambiguous on the question of whether English *do* is the overt allomorph of another head or a separate auxiliary. This analysis differs in important respects from earlier “repair” analyses of *do*-insertion in English, and argues that the choice of an *overt* element DO arises for economy reasons.

The role of *do*-support in the English inflectional system has in general played a central role in discussions of *economy* in natural language, addressing a two-fold question: why does *do*-support occur at all in the environments where it does, and why does it *not* occur elsewhere, both in other environments and other languages.

It is in this context that Chomsky (1991) discusses *do*-support. In this paper, Chomsky proposes that the “last resort” properties of *do*-support are due *not* to its being ordered comparatively late in the derivation, as in the repair analyses reviewed in section 4.2, but instead to its status as a *language-particular* process: Chomsky proposes that general principles of Universal Grammar are employed wherever possible, being less “costly” than language-specific rules.²⁶

The reason that the costly process of *do*-support is required at all is due to the lack of V^0 -to- T^0 movement, for Chomsky. Following (Pollock, 1989), he proposes that English main verbs are unable to raise to combine with inflectional material in T^0 (I^0 for both Chomsky and Pollock) because the intervening Agr^0 is morphologically impoverished and consequently “opaque” to ϑ -role assignment. Because Agr^0 is opaque, inflection in English must Lower from T^0 to V^0 . Lowering, however, leaves an unbound trace, violating the Empty Category Principle (ECP) and so requires subsequent re-raising of the V^0 - Agr^0 - T^0 complex at LF, where the opacity of Agr^0 is no longer problematic.

²⁶This proposal is developed at further length by Pesetsky (1989).

The impossibility of overt raising of the verb through Agr^0 makes this two-step derivation necessary. In a language like French where Agr^0 is *not* opaque (following Pollock), the shorter one-step derivation with overt movement is *mandated* by economy principles.

Now we arrive at the questions of *do*-support. Chomsky (1995) begins by considering *Do*-support in questions. He assumes an underlying structure as in (28), where Q^0 is an interrogative instance of C^0 :

(28) Q^0 John I^0 Agr^0 write books.

Chomsky further proposes that Q^0 is affixal, and must therefore be supported by Surface Structure by head movement to it. To prevent the lowering of I^0 and Agr^0 that would render such head movement impossible, Chomsky proposes that English inserts the “dummy element” *do* as part of a “language-specific process” (Chomsky, 1995, p. 139). *Do* is inserted below the position of Agr^0 (possibly the base position of modal verbs), and then raises to Agr^0 , I^0 , and finally to Q^0 , satisfying the latter’s requirements as an affix.

Similarly, in negative sentences, insertion of *do* resolves the problem of re-raising past negation at LF. The story is slightly more complex in its details, however: negation involves a head that intervenes between Agr^0 and I^0 . This head is occupied, and movement from Agr^0 to I^0 passes over it. This would create a violation of the ECP at LF, but Agr^0 , not being semantically interpreted, can be deleted at LF – or rather, the trace in Agr^0 can be so deleted. This deletion leaves an empty category [*e*] behind, which no longer would violate the ECP, as that is a condition only restricting the distribution of traces (as in Chomsky, 1986a).²⁷

Deletion of the trace in Agr^0 , however, can only rescue movement over negation when that movement is overt, as in French and with English auxiliaries. When surface movement involves the *lowering* of Agr^0 , the trace of this lowering is also deleted at LF, before re-raising of the verbal complex. This verbal complex then moves to I^0 , stopping in the intervening position [*e*] and leaving a trace there. This trace, being substantive (V^0) and interpretable, cannot itself be deleted, and so this movement violates the ECP.

This problem is resolved by inserting non-contentful *do* below Agr^0 and raising it overtly, as in questions.²⁸ If we assume, however, that a new head cannot be inserted

²⁷The movement would nonetheless violate the HMC, but Chomsky argues that the HMC has only the status of a descriptive generalization, being reducible (where correct) to the ECP.

²⁸As far as I am aware, this analysis provides no direct account of the presence of *do* in VP ellipsis.

counter-cyclically, the successful derivation must be one in which *do* was part of the original numeration, and was merged low in the clause before such merger was derivationally necessary.

This raises the question of why *do*-support is not *always* possible in (non-emphatic) declaratives. By themselves, principles of economy predict that it should be: insertion of *do* followed by movement of *do* involves two derivational steps, the same as lowering of I^0 and Agr^0 followed by their re-raising.

Chomsky proposes that it is *do*-support's status as a language particular process that makes any derivation that implements it less economical than one that does not. What is meant by calling it a "process", however, is not entirely clear: Chomsky's account of *do* essentially amounts to the inclusion of an additional semantically contentless auxiliary or head in the original numeration. Unless the selection of such a head from the lexicon carries some special derivational burden, it is not clear how the language-particular status of *do*-support would bear on the economy of a derivation.²⁹

The proposal of the previous section, however, offers another way in which we can view the appearance of an overt default element DO as dispreferred, or less economical. Rather than assuming that DO reflects a separate default head, available only in some languages or some circumstances, I proposed that the application of DO-support always requires the violation of an otherwise general preference to pronounce v^0 and V^0 in the same position, much as verb doubling constructions require a violation of the otherwise general preference to pronounce only one copy of a moved constituent. This provides a way of reformulating the idea that DO-support is dispreferred because it is a language-particular process: as in other cases in which general principles come into conflict, languages make individual choices about which principles to prioritize over others.

²⁹Furthermore, we have seen that DO-support processes occur in a number of languages, calling into question whether it is in fact meaningful to call it a "language particular" process in the first place.

In fact, Chomsky acknowledges in a footnote that *do*-support may be the reflex of more general "parameter-setting operations" (Chomsky, 1991, fn. 20). This admission, however, undermines the account of why *do*-support is restricted to the environments in which it is required: Chomsky's only proposal on this count is that *do*-support imposes special burdens on economy because it is *not* a general principle of Universal Grammar.

4.6 Conclusion

The central aim of this chapter has been to address the apparent conflict between the analysis of auxiliary verbs, particularly BE, developed in chapter 2, and the approach to English *do*-support widely accepted since Chomsky (1957). The apparent conflict stems from the fact that both propose that a different “default” item (BE in one case, DO in the other) is a “last resort” repair mechanism triggered by the presence of stranded inflectional material.

Though DO-support has often been discussed as a language-particular process of English, I showed in section 4.3 that analogous phenomena have been described in a wide range of typologically diverse languages. Looking beyond English, moreover, the hypothesis that DO-support is a repair for stranded inflection, in T^0 or elsewhere, becomes untenable. Monnese, Breton, and the mainland Scandinavian languages all employ DO-support despite the availability of verb movement to T^0 . On the basis of a review of these languages, I argued in section 4.3 that DO cannot be understood as a verb of last resort. This resolves the apparent challenge posed by standard analyses of DO-support for the more general analysis of auxiliary BE developed in chapter 2.

Section 4.4 sketched a development of proposals previously advanced in the literature that DO corresponds in some way to a low functional head, specifically v^0 . I argued that DO, rather than reflecting the *failure* of T^0 to establish a morphological relationship with the verb, is in fact a morphological *reflex* of a relationship between them, arising in environments where the requirement that T^0 and v^0 be adjacent is in conflict with the requirement that V^0 be realized within the VP. Though much work remains to be done regarding the details of this proposal, it represents a potentially cross-linguistically unified approach to DO-support that is compatible with the general approach to verbal inflection advanced in this dissertation.

This approach was contrasted with a number of alternative analyses of DO-support in section 4.5. Several of these have in common the proposal that DO corresponds to a low functional head, either an auxiliary verb or an overt instance v^0 . What is missing from such accounts, I argued, is an explanation of *why* that low functional head is present, or fails to combine with the main verb, in all and only the environments of DO-support.

Chapter 5

Verbal inflection and the left periphery: Counterfactuals

5.1 Introduction

In chapter 2 I proposed that a functional head F^0 specified for verbal inflectional features will have one of three possible effects on a syntactic derivation. In the simplest case, the features will Agree with a lower verb and be morphologically interpreted in the lower position. It is also possible for that Agree relation to trigger head movement, however, in which case both the verb and the inflectional features would be interpreted in the position of F^0 itself. Finally, it is possible that the features of F^0 are *unable* to Agree with a verb, in which case they will be *stranded* and will trigger morphological insertion of an auxiliary verb.

This range of possibilities is predicted to apply to any functional head bearing inflectional features. In this chapter I apply it to *counterfactual* inflection, which has been argued to be associated with the left periphery (Arregui, 2004, 2009; Ritter and Wiltschko, 2010, a.o.).

I argue that this approach provides accounts of two little-discussed phenomena linked to counterfactuality: conditional inversion and counterfactual auxiliaries.

Conditional inversion is exemplified by the contrast in (1). In (1b), the antecedent is marked by inversion of the subject and auxiliary, rather than by the complementizer *if*.

- (1) a. If it had rained, the ground would be wet.
b. Had it rained, the ground would be wet.

Building on the association between conditional inversion and counterfactuality (Iatridou and Embick, 1994), I propose that conditional inversion represents a case of head movement triggered by inflectional Agreement with an element in the left periphery.

Counterfactual auxiliaries are found in dialects of Arabic, exemplified in (2b). In this clause counterfactual inflection is expressed on an auxiliary, allowing non-counterfactual inflection to persist on the main verb:

- (2) a. katb-at
write-3SG.F
“She wrote.”
- b. kaanat katb-at
be.PAST.3SG.F write-SG.F
“She would have written.” *Palestinian Arabic* (Karawani and Zeijlstra, 2010, 2, ex. 1,6)

In contrast to conditional inversion, I argue that counterfactual auxiliaries arise due to *stranding* of counterfactual past features.

This chapter begins in section 5.2 with a review of the properties of counterfactual inflection, confirming its identity with temporal inflectional marking and reviewing the arguments that it is associated with left-peripheral positions. This provides the basis for the expectation that counterfactual marking strategies will mirror the patterns of verbal inflection and auxiliary use discussed in chapter 2. Section 5.3.1 develops a detailed account of conditional inversion in terms of inflectional-agreement-driven head movement, and section 5.4 develops the stranding analysis of counterfactual auxiliaries.

5.2 Counterfactual inflection

As stated in the introduction, the central argument of this chapter is that the theory of verbal inflection and auxiliary verbs proposed in chapter 2 automatically extends to several phenomena related to the use of “temporal” inflectional morphology to mark counterfactuals. This is particularly significant given that conditional inversion and counterfactual auxiliaries have previously been treated as somewhat exceptional phenomena: the ability to integrate them into the predicted typology of inflectional patterns represents an empirical success of the current account.

Grammatically counterfactual clauses convey that the proposition they express is contrary-to-fact. The focus of this chapter is on counterfactual *conditionals*, which express implicational relationships that are presumed not to hold in the actual world.¹

This section begins by reviewing the properties of temporal inflection used to mark counterfactuals.

It is widely known that many languages use past tense morphology to mark counterfactual clauses, particularly counterfactual conditional antecedents (Hale, 1969; Steele, 1975; James, 1982; Palmer, 1986; Fleischman, 1989; Iatridou, 2000; Van Linden and Verstraete, 2008, a.o.), including all the languages described in the previous section. Iatridou (2000) refers to this past morphology as “fake” in the sense that it does not contribute past tense meaning: counterfactual antecedents with “fake” past are compatible with present- and future-oriented adverbs (3), unlike “real” past-tense clauses (4).

- (3) a. If they **were** outside **right now**, they would have gotten frostbite.
 b. If the students **left tomorrow**, they might miss the snowstorm.²
- (4) a. *They were outside right now.
 b. *The students left tomorrow.

The following examples illustrate the occurrence of counterfactual “past” in Greek, Zulu, and Russian:

- (5) An **peθene** o arx̄iyos θa ton θavame stin korifi tu vunu
 if die.**PAST**.**IMPF** the chief FUT him bury.**PAST**.**IMPF** on.the top the mountain
 “If the chief died, we would bury him on the top of the mountain.” (Iatridou, 2000, 236, ex. 14)
- (6) ukuba be-ngi-zo-phuma kusasa be-ngi-zo-fika
 if **IMPF**.**PAST**-1SG-FUT-leave tomorrow **IMPF**.**PAST**-1SG-FUT-arrive
 ngo-Lwesihlanu
 on.Friday
 “If I left tomorrow, I would arrive on Friday.” (Halpert, under review, 3, ex. 7c)

¹Counterfactuality is also associated with clauses expressing *desires* or *wishes*, such as optative clauses and the complements to verbs such as *wish*.

²Technically this is not a counterfactual, but a “future less vivid” (FLV) conditional, a term adopted by Iatridou (2000) from grammars of classical Greek (fn. 5). FLV conditionals share the morphological properties of counterfactuals; Iatridou proposes that they express an implicature that the antecedent is comparatively *unlikely* in the actual world.

- (7) Esli by Dzon umer, my poxoroni-l-i by ego na gor-e.
 if SUBJ J. die.PFV.PAST we bury.PFV.PAST.PLSUBJ he.ACC on mountain-LOC
 “If John died, we would bury him on the mountain.” (Sergei Tatevosov, p.c.)

This fake past morphology is an alternative to dedicated counterfactual morphology. Hungarian, for example, marks counterfactual clauses with a dedicated morpheme *-na*, as shown in (8) (=Iatridou, 2009, 1, ex. 1-2, citing Aniko Csirmaz p.c.):

- (8) a. *Non-counterfactual conditional*
 ha holnap el-indul, a jo:vő hétre oda-ér
 if tomorrow away-leave the following week.onto there-reach
 “If he leaves tomorrow, he will get there next week”
- b. *Counterfactual conditional*
 ha holnap el-indulna, a jo:vő hétre oda-érne
 if tomorrow away-leave-**CF** the following week.onto there-reach-**CF**
 “If he left tomorrow, he would get there next week.”

Other “fake” inflection appears to occur in counterfactuals. The most widely discussed of these is imperfective aspect marking (Iatridou, 2000; Arregui, 2004; Ippolito, 2004), though it is less widely discussed and less well understood than past inflection in counterfactuals. In most languages with imperfective marking in counterfactuals, this morphology “comes along” with past tense marking: counterfactuals are not simply marked by *past* but by *past imperfective*, even when a perfective interpretation is pragmatically required. This is illustrated by the Greek example in (9) (=Iatridou, 2000, 236, ex. 14), where the predicate *die* must be interpreted perfectly despite the occurrence of the *imperfective* stem.

- (9) a. [An **peθene** o arxivos] tha ton θavame stin korifi tu
 if die.PAST.IMPF the chief FUT him bury.PAST.IMPF on.the top the
 vunu
 mountain
 “If the chief died, we would bury him on the top of the mountain.”

A slightly different pattern occurs in Hindi, where the habitual suffix *-taa* is used as a counterfactual marker without an accompanying (overt) past marker Bhatt (1997). As Bhatt demonstrates, *-taa* occurs not only in counterfactual antecedents without any habitual interpretation, but also *doubly* occurs in habitual counterfactuals (10) (=Bhatt, 1997, 2, ex. 6).

- (10) a. agar Ram phal khaa-taa
 if Ram fruit ate-HAB
 “If Ram ate the fruit (CF)...”
- b. agar Ram-ne phal khaa-yaa ho-taa
 if Ram-ERG fruit ate-PFV be-HAB
 “If Ram had eaten the fruit (CF)...” (Perfective CF)
- c. agar Ram phal khaa-taa ho-taa
 if Ram fruit ate-HAB be-HAB
 “If Ram had been eating fruit habitually (CF)...” (Habitual CF)

Bhatt argues, however, that the habitual marker *-taa* is actually associated with covert past tense features. If this is the case then Hindi can be assimilated to languages where imperfective always *co-occurs* with past in counterfactuals.

There is no consensus in the literature on the motivation for “past” inflection in counterfactuals, though a number of proposals have been made seeking to *unify* the occurrence of the same morphology in past and counterfactual contexts.

One way in which they have been unified is through the proposal that the “past” of counterfactuals is, contrary to appearances, a true temporal past; Ippolito (2002) and Arregui (2009) both propose that past morphology in counterfactuals reflects a past tense *semantics* that is involved in the generation of counterfactual meanings.

A more widely adopted view has been that there is a more *abstract* relationship between past and counterfactuality. Early work proposed that past marking was *metaphorically* extended to indicate a more abstract notion of remoteness Isard (1974); Fleischman (1989, a.o.). A similar intuition has been captured in more recent work by proposing that temporal past and modal counterfactuality express a single more abstract *feature*. Iatridou (2000) proposes that both involve an “exclusion” feature in T^0 signifying remoteness, which is generally interpreted as involving remoteness of *times*, but which can also be interpreted as involving remoteness of *worlds*.

Along similar lines, Ritter and Wiltschko (2009, 2010) propose that T^0 generally expresses an abstract [\pm coincidence] feature (following proposals by Demirdache and Uribe-Etxebarria, 2000), which *anchors* the clause by some deictic property of situations. In familiar European languages clauses are anchored via *times*, but Ritter and Wiltschko propose that Halkomelem Salish indexes clauses by *location*, and that Blackfoot (Algonquian) indexes clauses via event *participants*. Ritter and Wiltschko extend this to counterfactual

“past”, proposing that counterfactual C^0 can value an uninterpretable [-coincidence] feature on T^0 .

A number of proposals have also been made concerning the occurrence of imperfective morphology in counterfactuals. Iatridou (2000, 2009) claims that imperfective is a *default* aspect; Arregui (2004) claims that it reflects incompatibility between counterfactuals and *perfective*; Ippolito (2004) claims that imperfective has a modal use that reflects indirect evidence on the part of a speaker. Observing that some languages (including Arabic) require *perfective* aspect in counterfactuals, rather than imperfective, Bjorkman and Halpert (in prep) propose that the occurrence of imperfective in counterfactuals is an illusion arising from a default imperfective interpretation of an aspectually-unspecified past morpheme in these languages.

Regardless of differences in implementation, the unification of temporal and counterfactual uses of the same inflectional markers is well-established. Within a feature-based approach to inflection, this unification can be formalized by proposing that past tense and counterfactual modality can be expressed by one and the same *feature*. For the purposes of this chapter I adapt the terminology of Ritter and Wiltschko to the feature system adopted in chapter 2 and refer to this feature as [INFL:NON-COIN] (i.e. *non-coincidence*).

In spite of the disagreements about the *nature* of counterfactual “past”, there is more general agreement that counterfactual “past” features are associated with a different – and structurally *higher* – position than temporal past features (Aygen, 2004; Arregui, 2009; Ritter and Wiltschko, 2010; Bjorkman, 2011b).

In several cases, the association between conditional inversion and counterfactuals has been cited as evidence for a left-peripheral position for counterfactual features: Ritter and Wiltschko (2010), for example, appeal to the link between conditional inversion and counterfactuals in English as evidence for their proposal that uninterpretable “past” (non-coincidence) on T^0 can be valued by a counterfactual instance of T^0 . This link will be the focus of section 5.3 in this chapter; however, as one of the goals of this chapter is to provide an analysis of conditional inversion, partly on the basis of the structural position of counterfactual features, evidence for this structural position must be found in some other domain, in order to avoid circularity of reasoning.

Empirical support for the association of counterfactual “past” with a higher structural position than tense inflection can be found in the relative order of “past” and conditional

suffixes in Turkish conditionals (Aygen, 2004). As we will see below, a single affix appears in both temporal past and counterfactual contexts, but in counterfactual contexts it occurs in an arguably *higher* structural position.

Conditional antecedents in Turkish are marked by a conditional suffix on the main verb $(-y)sa$. Turkish also has a past tense marker $(y)di$. These morphemes co-occur in both non-counterfactual conditional antecedents with a temporally past interpretation, and in counterfactual antecedents regardless of temporal interpretation.

In temporally-past non-counterfactual antecedents, the past morpheme occurs to the *left* of the conditional marker, as shown in (11):

(11) Indicative: **V-PAST-COND**

Dün gece Can erken yat-**di-ysa** sabah erken kalk-abil-ir.
 Last night John early sleep-PAST-COND morning early get.up-MOD-PAST
 “If John went to bed early last night, he can get up early this morning.” (Ulutas, 2006, 3, ex. 6a)

In counterfactual antecedents, by contrast, the order is reversed: the past morpheme occurs to the *right* of the conditional morpheme, as we see in (12):

(12) Counterfactual: **V-COND-PAST**

Dün gece Can erken yat-**sa-ydı** sabah erken kalk-ar-di.
 Last night John early sleep-COND-PAST morning early get-up-AOR-PAST
 “If John had gone to bed early last night, he would have got up early in the morning.” (Ulutas, 2006, 3, ex. 6b)

As Aygen observes, the change in the relative order of morphemes in the antecedent clauses of (11) and (12) can be reasonably argued to result from a change in the syntactic structure underlying the morphemes. If we assume that the past morpheme is associated with T^0 when it is interpreted temporally, as in (11), then the Mirror Principle (Baker, 1985) leads us to the conclusion that when the same suffix occurs further to the right it occupies a head higher than T^0 , somewhere in the T^0 domain.

Turkish thus provides direct evidence, independent of conditional inversion, that counterfactual “past” is associated with a higher structural position than temporal information; that is to say, that it is associated with a left-peripheral position.

Generalizing this conclusion beyond Turkish not only provides the framework for accounting for conditional inversion and counterfactual auxiliaries, as we will see in the next section, but also provides a structural basis for different interpretations of [INFL:NON-COIN]. When in T^0 , this feature is interpreted temporally as past tense; when in the left periphery it is interpreted modally as counterfactual.

Semantic proposals developed by Ippolito (2002) and Arregui (2009) argue on quite a different basis that counterfactual “past” is associated with a higher structural position than temporal past. So far in this chapter I have assumed that the correct semantic analysis of counterfactual “past” inflection does not involve *temporal* pastness, following earlier authors who have noted that “past” inflection in counterfactuals is compatible with non-past interpretations. Both Ippolito and Arregui, however, argue that counterfactual interpretations result from *temporal* past semantics being interpreted with wider scope than modality: this wide scope causes temporal past to restrict the time with respect to which the modal is interpreted (rather than the time at which the event took place). In other words, the wide-scope past tense semantics identifies a point in time with respect to which the counterfactual would have been a possible future.

This approach to the semantics of counterfactuals is in principle compatible with the core syntactic proposals of this chapter, which will require simply that counterfactual “past” correspond to syntactically visible features in the left periphery. Should these proposals ultimately prove to be correct, they would therefore provide independent support for the association between counterfactual “past” features and a high structural position. In this chapter, however, I will remain partly agnostic regarding the correct *semantic* analysis of counterfactual “past”; this prevents Ippolito and Arregui’s proposals from constituting a strong argument in this domain.

Regardless of the precise semantic characterization of counterfactual “past”, finally, its association with a position in the C^0 domain would be compatible with general proposals linking modal interpretations and modal morphology with positions above T^0 : this is particularly true of work on the subjunctive (Farkas, 1993; Portner, 1997; Giorgi and Pianesi, 1997, 2004; Giorgi, 2009; Giannakidou, 2009; Roussou, 2009, 2010, among many others).

5.2.1 C⁰, T⁰, and counterfactual inflection

The previous section reviewed evidence that counterfactual inflection is associated with the left periphery but morphologically realized in a lower position, on the finite verb of a clause. Once again, then, we have encountered a domain of verbal inflection in which inflectional features appear to be associated with a higher position than they are eventually pronounced in. This provides yet further support for the “backwards” Agree approach proposed in chapter 2.

Counterfactual inflection *differs* from other types of inflection, however, in that it is “repurposed”: it is morphologically identical to inflection that marks *temporal* contrasts in non-counterfactual contexts. I have adopted the proposal that this morphological identity is due to counterfactual and temporal inflection resulting from the same syntactic feature, [INFL:NON-COIN], occurring in different structural positions.

If counterfactual [INFL:NON-COIN] originates on C⁰, however, it must somehow combine with the finite verb of the clause. In English, for example, “past” inflection can occur on an *in situ* verb (to the right of the adverb *actually*):

- (13) If the students actually **knew** the answer, they wouldn’t have to guess.

On the most straightforward application of the proposals in chapter 2, the occurrence of counterfactual “past” on V⁰ in a sentence such as (13) requires that none of the heads between C⁰ and V⁰ be specified for other inflectional features, as schematized in (14); if any were specified, they would intervene for the purposes of the Agree relationship, stranding the features in T⁰:

(14)

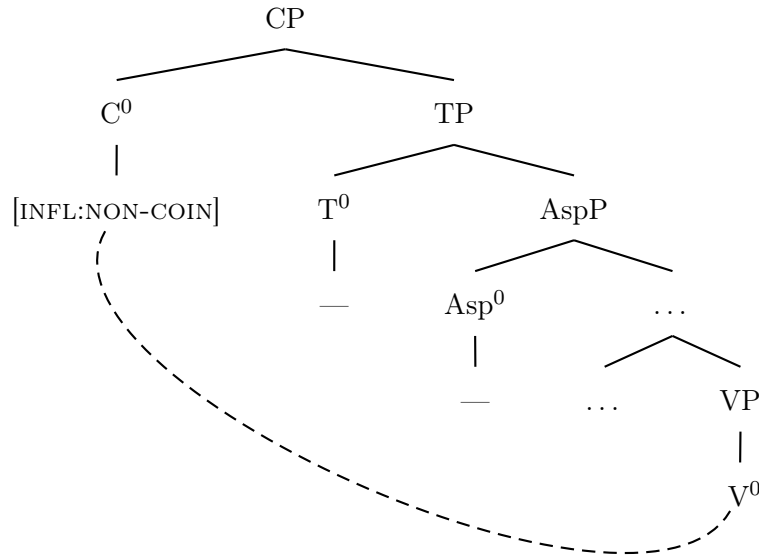

This structure assumes that T^0 is featurally unspecified in counterfactuals, allowing it to be bypassed by Agree. If this were the case, however, we would expect that T^0 would also be inactive for purposes of *head movement*, given the assumption that head movement, like phrasal movement, is triggered by Agree. Auxiliaries in counterfactual antecedents, however, occur in the same linear position (with respect to negation and adverbs) that they do in non-counterfactuals, suggesting that they move to the same position (i.e. to T^0):

- (15) a. If the students were actually studying ...
b. If it were not raining ...

This suggests that T^0 is syntactically visible in counterfactuals, interacting with Agree and head movement. Why, then, would it not intervene between C^0 and V^0 in a structure such as (15)?

I propose that the explanation is due to the fact that T^0 and C^0 are specified for the *same* features. As a result, Agree between T^0 and C^0 does not merely *assign* C^0 's feature to T^0 , but *overwrites* T^0 's feature value. This overwriting is a form of feature identification, and as a result the altered feature value is passed along to any other head T^0 itself has Agreed with – in particular, to an *in situ* V^0 . Feature identification is shown in (16) by subscripting:

(16)

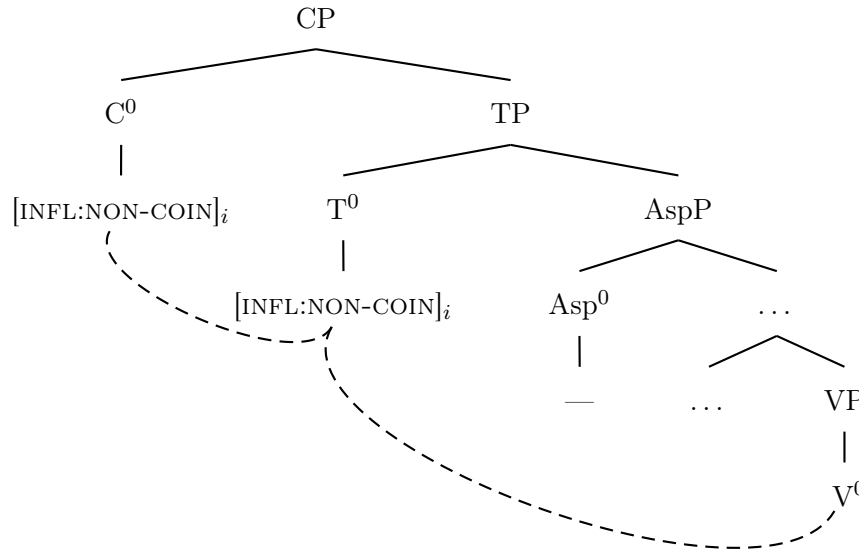

Applying the framework of chapter 2 to counterfactual inflection makes two further predictions. First, we predict that Agree between T^0 and C^0 should, in at least some languages, be accompanied by head movement between those positions. Second, we predict that if the features of C^0 are prevented from being realized on a verb, they will trigger insertion of an auxiliary.

The remainder of this chapter seeks to establish that both of these predictions are borne out, the first by conditional inversion and the second by counterfactual auxiliaries.

5.3 Conditional Inversion

As stated in the introduction to this chapter, conditional inversion is the marking of conditional antecedents by movement of the verb to the left periphery, in the absence of a dedicated marker such as *if*. It is illustrated in (17) for English, in (18) for German, and in (19) for Russian.

(17) English

- a. **If** I **had** known, I would have acted differently.
- b. **Had** I known, I would have acted differently.

(18) German (Iatridou and Embick, 1994, 190, ex. 2)

- a. **Wenn** Hans **kommt** dann geht Susanne.
if Hans comes then goes Susan

- b. **Kommt** Hans dann geht Susanne.
comes Hans then goes Susanne.
“If Hans comes, Susan goes.”

(19) Russian (Alya Asarina, p.c.)

- a. **Esli** by my **vyexali** vchera, my by uzhe priexali.
if BY we left yesterday, we BY already arrived
- b. **Vyexali** by my vchera, my by uzhe priexali.
left BY we yesterday, we BY already arrived
“If we had left yesterday, we would already have arrived.”

The complementary distribution between an overt complementizer and inversion has been taken as evidence that conditional inversion involves verb movement to (or through) C^0 since at least Den Besten (1983, fn. 3) (this is also proposed in Holmberg, 1986).

Relatively little work has been done on conditional inversion outside the verb-second Germanic languages, but Iatridou and Embick (1994) demonstrate a typological link between conditional inversion and counterfactuals.

I argue in this section that the existence of this link motivates an account of conditional inversion within the framework of verbal inflection developed in chapter 2. That system proposes that head movement is predicated on a pre-existing Agree relationship: a head X^0 cannot move to a head Y^0 unless X^0 and Y^0 Agree for some feature [F]. This extended to head movement Chomsky’s (1998) proposals regarding *phrasal* movement.

Applying this requirement to conditional inversion, we predict that conditional inversion should be possible only when C^0 and T^0 Agree for inflectional features.

This section proceeds as follows. First I review the evidence for a typological link between conditional inversion and counterfactuals, beginning from Iatridou and Embick’s (1994) observations. This link is connected to the presence of an Agree relationship between T^0 and C^0 in counterfactuals, as argued in section 5.2. This is put together into an account of conditional inversion in section 5.3.2.

5.3.1 Conditional inversion and counterfactuals

It is Iatridou and Embick (1994) who proposed the cross-linguistic association between conditional inversion and counterfactuals. They observe that all languages that allow conditional inversion at all allow it in counterfactual conditionals, while only a subset allow it

in indicative antecedents as well. Indeed, it appears to be only the verb-second Germanic languages that conclusively permit conditional inversion in indicative antecedents.

The distribution of conditional inversion is summarized in (20), adapted from Table 1 in Iatridou and Embick (1994). Estonian and Breton have been added to the review.

(20) *Crosslinguistic availability of conditional inversion*

	Counterfactuals	Indicatives
English	+	-
German	+	+
Dutch	+	+
Yiddish	+	+
Icelandic	+	+
Swedish	+	+
Old English	+	+
Middle English	+	+
Italian	+	-
French	(+) ³	-
European Portugese	+	-
Romanian	+	-
Russian	+	(-) ⁴
Bulgarian	+	-
Breton	+	(-)
Estonian	+	-

The following examples exemplify counterfactual conditional inversion in a number of these languages:

(21) *English*

- a. Were it raining, I would take an umbrella. (Counterfactual)

²This table does not include languages that lack conditional inversion altogether. The original table occurs in Iatridou and Embick (1994), p. 191.

³French conditional inversion is possible only with pronominal (clitic) subjects. Of interest, however, is the fact that this clitic-based inversion in French is possible only in counterfactuals, which supports the generalization proposed by Iatridou and Embick. Iatridou and Embick nonetheless indicate French inversion as (-) because it is restricted to clitics; I have chosen instead to mark it as (+).

⁴Iatridou and Embick give a tentative positive for the availability of conditional inversion in Russian indicative antecedents. My own consultations with Russian speakers, however, have suggested that this is not possible.

b. *Is it raining, I'll take an umbrella. (Indicative)

(22) *Italian*

Fosse Gianni arrivato in tempo, avremmo potuto uscire
be.PAST..SUBJ Gianni arrive.PTCP in time, we could go.out.INF
“Had John arrived in time, we could have gone out.” Munaro (2005, 75, ex.
5b)

(23) *Portuguese*

Tivesse eu menos dez anos (e) ter-me-ia apaixonado
have.PAST..SUBJ I less ten years (and) have-me-would fall.in.love.PTCP
“If I were ten years younger, I would have fallen in love.” (Rafael Nonato, p.c.)

(24) *Russian*

Vyexali by my vchera, my by uzhe priexali.
leave.PAST BY we yesterday, we BY already arrive.PAST
“Had we left yesterday, we would have already arrived.” (Alya Asarina, p.c.)

In addition to the languages discussed by Iatridou and Embick, patterns of conditional inversion in Breton, discussed by (Schafer, 1995), and Estonian, discussed by (Külmoja, 2005), appear to be similarly restricted to counterfactual contexts.

(25) *Breton* (Schafer, 1995, 145, ex. 15)

- a. Yann a chomje er get, m' am bije goulet gantan.
Yann PART stay.COND at home if PART have.COND.1SG asked with.him
“Yann would stay home if I had asked him.”
- b. Henez a vije da labourat du-man, am
that one PART be.COND to work house-this
bije goulet gantan.
PART have.COND.1SG asked with.him
“That one would work with our family, had I asked him.”

(26) *Estonian*⁵

- a. Kui Juhan oleks saanud linda-de-st head hinda, ta
If J be.COND get-PTCP flax-PL-ELAATIVE good-PART price-PART, he
oleks ostnud hobuse.
be.COND buy.PTCP horse.GEN
“If Juhan had gotten a good price for the flax, he would have bought a horse.”
- b. Oleks Juhan saanud linda-de-st head hinda, ta
be.COND J get-PTCP flax-PL-ELAATIVE good-PART price-PART, he

oleks ostnud hobuse.
be.COND buy.PTCP horse.GEN
“Had Juhan gotten a good price...”

Munaro (2002) also demonstrates that conditional inversion in a number of Northern Italian dialects is restricted to counterfactual antecedents.

Iatridou and Embick also observe that even in the Germanic languages, where conditional inversion is possible in both indicative and counterfactual antecedents, indicative inversion is often more restricted. In German, Dutch, and Swedish, inverted indicative antecedents must *precede* their consequent, while inverted counterfactual antecedents may either precede or follow their consequent, as shown in the following table:

These data all point toward a connection between conditional inversion and counterfactuals. In this chapter I will argue that the reason for this connection is an association between counterfactual inflection and the left periphery: the inflectional relationship between a left peripheral position and the verb provides the *basis* for movement of the verb. It is because indicative conditionals are *not* generally associated with dedicated inflection that they have a more restricted paradigm of inversion; I will propose that it is only languages with independently-available movement of the verb to C^0 in indicative clauses (e.g. V2 languages) that will allow conditional inversion in indicative clauses.

5.3.2 A syntactic account of conditional inversion in counterfactuals

The previous three sections have established that conditional inversion is associated with counterfactuals, that counterfactuals in the relevant languages are marked by “repurposed” inflectional morphology, and that there are reasons to believe that counterfactual inflectional morphology is associated with the clausal left periphery, i.e. the position to which the verb inverts in conditional inversion.

In this section I develop the proposal that the reason counterfactuals and conditional inversion are linked is that counterfactual clauses, unlike their indicative counterparts, automatically provide an Agree relationship between the left periphery and the verb, and this Agree relationship can form the basis of head movement from T^0 and C^0 .

First, let us establish that this kind of syntax-internal motivation for conditional inversion is necessary. Since at least Den Besten (1983) it has generally been accepted that conditional

⁵Thank you to Mark Norris and Mervi Kalmus for these Estonian examples.

inversion is somehow motivated by the absence of an overt complementizer in C^0 . We might understand this as some kind of interface requirement: either a phonological (PF) requirement that C^0 be filled, or some kind of semantic (LF) requirement for the creation of the semantics of a conditional antecedent.⁶

Any such interface motivation for movement, however, would apply equally in the case of indicative and counterfactual antecedents. That is, if conditional inversion occurs only to fill a C^0 head that does not contain a complementizer, then we would never expect to find the kind of systematic typological asymmetries between counterfactual and indicative antecedents described in the previous section. This relates more generally to a question about whether interface requirements can *ever* directly motivate syntactic processes, or whether they depend on syntax-internal mechanisms. I adopt the view that even movement required by an interface does not come ‘for free’, as it were. An example of this requirement in another domain can be found in Szabolcsi (2004), who argues that positive polarity items are semantically required to outscope negation, but can only move to do so when *independently* able to move.

It therefore appears that a motivation, whether phonological or semantic, for verb movement to C^0 is insufficient on its own to cause that movement to happen. Some additional syntax-internal trigger for the movement is also required. The evidence of the previous section suggests that such a trigger is more widely available in counterfactual than in indicative antecedents.

I have argued that one of the things that differentiates counterfactuals from indicatives

⁶It does not appear to be the case in languages with conditional inversion that there is a general PF requirement that C^0 be filled: English, for example, allows null complementizers in embedded clauses. A semantic requirement for conditional inversion, in the absence of a complementizer *if*, is more promising. This requires a non-vacuous semantics for *if*, contra the modal restriction analysis of conditionals (Kratzer, 1986, et seq.), where *if* marks which of two propositions acts as the restrictor of a modal, but does not change the denotation of that proposition.

Alternative analyses of conditionals have proposed that *if* makes a semantic contribution. One proposal of interest here is that conditional antecedents are (plural) definite descriptions of *worlds* (Schein, 2003; Schlenker, 2004; Bhatt and Pancheva, 2006). Schlenker (2004) specifically proposes that *if* is the equivalent of the definite determiner *the*, but applied to worlds rather than individuals. This raises the question of how a definite description of worlds could be created in the absence of the “determiner” *if*. Looking to the nominal domain provides one possible answer: in the absence of a determiner such as *the* it is possible to create definite descriptions via *movement*: these are *free relatives* (i.e. *the book I want to read* \approx *what I want to read*).

Suppose that conditional inversion represents the equivalent for definite descriptions of worlds: movement of a world argument itself, i.e. *head movement* from T^0 to C^0 , could create the required abstraction relation for a relativized structure. In the absence of *if*, then, conditional inversion creates a relativized structure interpretable as the definite description required for a conditional antecedent.⁷

is the presence of dedicated inflectional features in the left periphery. This immediately suggests that conditional inversion can be accounted for within the same framework developed in chapter 2. In that chapter I argued that verbal inflection is manipulated by Agree relationships between heads in the clausal spine: consequently, inflectional Agree is anticipated to be a possible trigger for head movement, much as Chomsky (1998, et seq.) proposes that phrasal movement depends on Agree between the moved phrase and the head to whose specifier the phrase moves.

Within such a framework, we in fact predict that inflectional features located in higher functional heads are also able to trigger head movement. The association between conditional inversion and *counterfactual* antecedents automatically follows from the fact that counterfactuals are associated with left-peripheral inflectional features. Indicative antecedents do not exhibit inversion precisely because they are not associated with dedicated inflectional morphology in the left periphery.

The exception will be indicative antecedents in languages with an independent mechanism allowing movement of the verb into the left periphery. Note in this context that the languages with indicative conditional inversion are the non-English Germanic languages, which are all *verb-second*. Whatever the analysis of verb-second phenomena, it must involve a general mechanism for verb movement to C^0 , which is reasonably available not only to main clauses but also to indicative antecedents.

The basic analysis of conditional inversion is thus as follows. In both inverted and non-inverted counterfactuals, a [INFL:NON-COIN] feature in C^0 Agrees with T^0 . If the complementizer *if* occurs in C^0 , however, this Agree relationship cannot be accompanied by movement. The result is that the finite verb occurs in its base position, but appears with (counterfactual) past inflection:

(27) *If you had . . .*

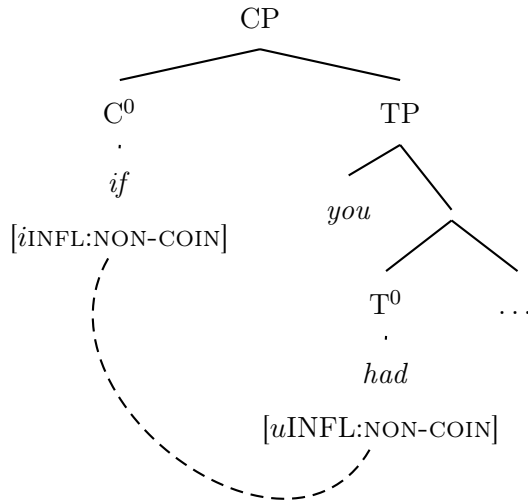

Complementizers such as *if* are not obligatory (in at least some languages), however, as the existence of conditional inversion demonstrates. In the absence of *if*, then, Agree between T⁰ and C⁰ can be accompanied by head movement, as illustrated in (28):

(28) *Had you ...*

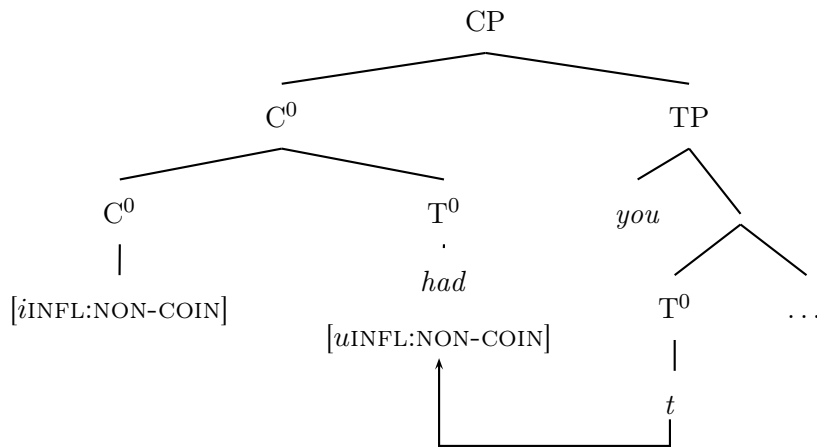

In this section I have argued that it is the presence of counterfactual inflectional features in the left periphery that provides the syntax-internal motivation for conditional inversion, accounting for the typological association between conditional inversion and counterfactuals.

Further evidence that conditional inversion involves an Agree relation with the left periphery comes from a further typological link between conditional inversion and *subjunctive* morphology.

In previous sections we have seen the typological correlation between conditional in-

version and *counterfactuals*, as originally described by Iatridou and Embick (1994). An interesting property is that all the languages with conditional inversion in counterfactuals are languages in which counterfactual antecedents are marked not merely by “past” but by *subjunctive* past. While several of the languages that lack conditional inversion altogether do use the past subjunctive in counterfactuals, two of them (Greek and French) lack a morphologically distinct past subjunctive paradigm.⁸

Iatridou and Embick (1994) do observe a link between subjunctive morphology and conditional inversion in Icelandic. As previously mentioned, the verb-second Germanic languages do not restrict conditional inversion to counterfactuals. In Icelandic, however, non-counterfactual conditionals allow conditional inversion only with (present) subjunctive morphology, as shown in (29) (=Iatridou and Embick, 1994, 192, ex. 7). The present subjunctive is *not* possible in uninverted conditionals.

- (29) a. Ef hann hefur faridh, eg kom
 if he has.PRES.IND gone, I come
 “If he has gone, I will come.”
- (i) Hafi hann faridh, eg kom
 has.PRES.SUBJ he gone, I come
 “If he has gone, I will come.”
- (ii) *Hefur hann faridh, ...
 has.PRES.IND he gone
- (iii) *Ef hann hafi faridh, ...
 if he has.PRES.SUBJ gone

The syntax and semantics of the subjunctive mood remain a widely debated issue, particularly as regards the selection of the subjunctive in complement clauses of certain embedding verbs (see, for example, Farkas, 1993; Portner, 1997; Giorgi and Pianesi, 1997, 2004; Giorgi, 2009; Giannakidou, 2009; Roussou, 2009, 2010; among many others), and also in imperatives (Rivero, 1994; Zanuttini, 1997; Han, 2000).⁹

Though this literature has rarely focused on the source of the subjunctive in conditional clauses, a broad consensus has emerged that the subjunctive is associated in some way with

⁸Greek marks counterfactual antecedents with the imperfective past, while French employs the imperfective past in conditional antecedents. It could be argued that French does exhibit counterfactual inversion, though it is limited to clauses with pronominal (clitic) subjects. Interestingly, however, French *stylistic* inversion has also been noted to be associated with subjunctive mood in embedded contexts, supporting the association between subjunctive mood and movement into the left periphery (Kayne and Pollock, 1978, et seq.).

⁹Many languages form *negative* imperatives via the subjunctive mood.

the left periphery. The co-occurrence of subjunctive morphology with environments that support verb movement into the left periphery supports the view that such movement is predicated on a pre-existing Agree relationship.

In conclusion, the typological correlation between counterfactual clauses and conditional inversion suggests that some property unique to the structure of counterfactuals is able to provide a required syntactic *trigger* for conditional inversion. I have suggested that what counterfactuals provide is an Agree relationship between the left periphery and T^0 , which is established by counterfactual inflectional features. This relationship is available to all past- or subjunctive-marked counterfactuals.

The restricted distribution of conditional inversion outside out counterfactuals, I suggest, is due to the absence of specifically indicative inflection in conditional antecedents. The lack of specifically indicative inflection reflects the absence of an Agree relationship between the left periphery and T^0 , and consequently the absence of a trigger for movement of T^0 to C^0 . Conditional inversion in indicative antecedents is predicted to be available, as a consequence, only in languages that have *general* verb movement to C^0 in indicative clauses. This generally-available movement can apply in conditional antecedents, satisfying the requirement (whether semantic or phonological) that C^0 be filled in the absence of an overt complementizer. This is the case in the V2 Germanic languages.

5.3.3 Limited conditional inversion in English

This section turns to the distribution of conditional inversion in English, which is more restricted than seen in the other languages discussed so far. As Pesetsky (1989) was the first to observe, contemporary English restricts conditional inversion not only to counterfactuals, but to three counterfactual auxiliaries: *had*, “non-obligational” *were* and *should*. This can be seen in (30): (30a-d) are all grammatical as either inverted or non-inverted counterfactuals, while (30e-g) are possible only in non-inverted forms:

- (30) a. (i) If I had known the answer, I would have told you.
(ii) Had I known the answer, I would have told you.
- b. (i) If anyone were to find out, Peter would be embarrassed.
(ii) Were anyone to find out, Peter would be embarrassed.
- c. (i) If anyone were home, the lights would be on.

- (ii) Were anyone home, the lights would be on.
- d. (i) If the alarm should go off, the building would be evacuated.
- (ii) Should the alarm go off, the building would be evacuated.
- e. (i) If I could scale this wall like Spiderman, I wouldn't need a ladder.
- (ii) *Could I scale this wall like Spiderman, I wouldn't need a ladder.
- f. (i) If we were (supposed) to wait for them, they would have said something.
- (ii) *Were we (supposed) to wait for them, they would have said something.
- g. (i) If someone would turn off the light, we could start the movie.
- (ii) *Would someone turn off the light, we could start the movie.

Of particular interest is the fact, observed by Pesetsky, that *do*-insertion is not triggered by conditional inversion, unlike other cases of V⁰-to-C⁰ movement:

- (31) a. If I knew the answer, I would tell you.
- b. *Did I know the answer, I would tell you.

The ungrammaticality of examples such as (31b) is a relatively recent development in English. Visser (1969, §1437) cites the following two examples from the first half of the twentieth century:

- (32) a. As [Bohun] lay there he thought of what he would do **did** Markovitch really go off his head.
(1919, Sir Hugh S. Walpole, *Secret City* 404)
- b. There are other articles, to which, **did** time permit, we might draw attention.
(1931 Curme, *Syntax* 327)

Of the English auxiliaries that occur in conditional inversion, *were* is a subjunctive form that contrasts morphologically with the indicative past *was*. For some speakers subjunctive *were* is not required in uninverted conditionals, leading to variation as in (33):

- (33) a. If anyone were/was to find out, Peter would be embarrassed.
- b. If anyone were/was home, the lights would be on.

Despite the variation in (33), however, subjunctive *were* is non-optional in conditional inversion for at least some speakers, as shown by the impossibility of (34a-b):¹⁰

- (34) a. *Was anyone to find out, Peter would be embarrassed.
b. *Was anyone home, the lights would be on.

This suggests that conditional inversion in English is dependent on the occurrence of counterfactual subjunctive morphology, at least in the case of *be*.

Similarly, Pesetsky observes that the *should* that occurs in conditional inversion (in contrast to deontic *should*) appears to be in complementary distribution with *would*: this *should* occurs *only* in the antecedent of conditionals, an environment in which *would* cannot occur. This is illustrated by (35) (=Pesetsky, 1989, 7, ex. 18):

- (35) a. If there should be a riot, it would be bad for the cause.
b. *If there would be a riot, it would be bad for the cause.
c. *If there should be a riot, it should be bad for the cause.
d. *If there would be a riot, it should be bad for the cause.

Of the three auxiliaries that invert in English counterfactuals, there is thus evidence that two of them – *were* and *should* – are overtly subjunctive. An available analysis of conditional inversion in English is that it rests not merely on an inflectional Agree relationship between the left periphery and T^0 , but specifically on an Agree relationship for inflectional *subjunctive* features. As proposed at the end of the last section, such features would potentially be

¹⁰A Google search for “was I you, I’d” does turn up some examples of conditional inversion with non-modal *was*:

- (i) a. Was I you, I’d leave the heater issue for last.
www.thetruthaboutcars.com/2011/02/down-on-the-mile-high-street-1966-dodge-a100/
b. Was I you, I’d be more interested in whether the barrel is chromed lined, than who made the upper.
www.ar15.com/archive/topic.html?b=3&f=118&t=440696

It is possible that these examples represent a relatively fixed expression, however: only one result (repeated verbatim on several websites) appears for the similar search “was I him, I’d”, and no results appear for “was I her, I’d”.

¹⁰Elizabeth Cowper (p.c.) observes that a number of frozen expressions in English also exhibit inversion with a frozen present subjunctive *be*:

- (ii) a. **Be** he alive or **be** he dead, I’ll grind his bones to make my bread. (Jack and the Beanstalk)
b. **Be** he ever so rich. . .

associated with a projection Mood⁰.¹¹

This provides a potential handle on how English conditional inversion might come to be restricted to such a greater extent than general T⁰ to C⁰ movement is. In questions, for example, all elements that can occur in T⁰ can invert to C⁰.

Observing that deontic *were (to)* (*The children were to call the police if anything went wrong.*) and *should* (*You should do the right thing.*) fail to invert, Pesetsky proposes that conditional inversion is limited in English to auxiliaries that do not assign ϑ -roles.¹² Within the framework of chapter 2, we can frame the restriction in a different way: the auxiliary verbs that invert are those whose content is limited to their formal inflectional features.

The contrast between inversion in questions and inversion in conditionals poses a problem for Pesetsky: arguing that certain auxiliaries are unable (whether for reasons of ϑ -opacity or because they consist of more than abstract inflectional features) to occur in C⁰ appears to incorrectly predict that inversion in *questions* should show the same lexical restrictions.

If, as I have suggested here, the projection Mood⁰ is centrally implicated in the availability of conditional inversion in English, with movement of the verb triggered by Agree for inflectional subjunctive features, this conflict does not necessarily arise. Specifically, I propose that it is Mood⁰, rather than C⁰, that imposes the restriction found in English conditional inversion. This head is not involved at all, however, in verb movement in questions; as a result we do not find a lexical restriction to semantically vacuous auxiliaries in questions.

¹¹Indeed, it appears that subjunctive, rather than counterfactual past, provides a better description of the environments of conditional inversion in English. Modal *should* does not appear to be restricted to past-marked counterfactuals, despite the fact that it is historically the “past” (preterite) form of *shall*.

This is demonstrated by (i) and (ii). English is a language in which counterfactual “past” marking is required to occur in *both* the antecedent and the consequent of a conditional, when it occurs at all. The absence of counterfactual “past” in the consequent clauses of (i) therefore shows that *should* does not count as “past” in the antecedent. Despite this, *should* is able to invert in both (ib) and (iib).

- (i) a. If there { is / should be } a riot, it will be bad for the cause.
b. Should there be a riot, it will be bad for the cause.
- (ii) a. If the line { breaks / should break }, it will have to be replaced.
b. Should the line break, it will have to be replaced.

Given the gradual loss of *shall* in contemporary English, there is very little morphological evidence that *should* is a preterite form, so its failure to trigger matching “past” inflection in the consequents in (i) and (ii) is not entirely surprising. What is surprising is that the occurrence of *should* nonetheless seems to convey the “reduced possibility” interpretation that is characteristic of past-marked future-less-vivid conditionals, in spite of the absence of any actual “past” inflection.

¹²Pesetsky links this to the proposal by Pollock (1989) that main verbs do not raise to Agr⁰ because English Agr⁰ is ϑ -opaque.

Finally, Pesetsky raised the question of why, if the auxiliaries that invert in English are those that contribute purely abstract modal or temporal information, “auxiliary” *do* cannot invert. In chapter 4, however, I argued against the traditional analysis of *do* as a semantically vacuous realization of stranded inflectional features. I proposed instead that it reflects the realization of v^0 in a position separate from the main verb. In this case, the failure of *do* to participate in conditional inversion is suddenly convergent with the failure of “theta-assigning” modals to invert: it is not a semantically vacuous auxiliary, but instead the overt realization of a contentful syntactic head.

5.3.4 Conditional inversion: summary

In summary, conditional inversion illustrates a case of head movement to a position in the left-periphery that is nonetheless motivated and conditioned by the same factors involved in head movement lower in the clause, between heads such as Voice^0 , Asp^0 , and T^0 . The link between conditional inversion and counterfactuals results from the existence of “fake” inflectional features in the left-periphery of counterfactuals. As we will see in the next section, we find yet further parallels in that inflectional features can also be *stranded* in the left periphery, leading to patterns of *counterfactual auxiliaries*.

5.4 Auxiliaries used to support “fake” tense and aspect

In all of the cases discussed so far in this chapter, counterfactual “past” inflection appears to prevent the expression of true temporal tense. In English, for example, “past” marking in counterfactuals such as (36) is compatible with both past- and future-oriented adverbs.

- (36) If you read the news (yesterday/tomorrow), you would know what was going on in the world.

It is only by using the pluperfect, as in (37), that interpretations can be restricted to past times.

- (37) If you had read the news (yesterday/*tomorrow), you would know what was going on in the world.

In section 5.2.1 it was proposed that the temporal features of T^0 are overwritten due to their formal identity to the counterfactual features in C^0 : languages such as English do not allow two separate instantiations of the same feature “type” in a single clause. In a subset of languages, counterfactual and temporal versions of the same inflection can co-occur in a single clause, due to the availability of an auxiliary strategy.

In Hindi, for example, counterfactual clauses are marked by a suffix *-taa*, which normally marks habitual aspect. The habitual use of *-taa* is shown in (38):

- (38) Ram phal khaa-taa hai/thaa
 Ram fruit eat-HAB be.PRES/be.PAST
 “Ram eats/used to eat fruit.”

Aspect in Hindi is marked on the main verb, while tense is marked on a finite auxiliary form of BE. The sole exception is the past perfective, which consists of a single inflected verb, as in (39). The traditional approach to such forms is that they involve simple *past* inflection, which receives a default perfective interpretation.

- (39) Ram-ne Sita-ko dekh-aa
 Ram-ERG Sita-ABS see-PFV
 “Ram saw Sita.”

As we already saw in (10), repeated in (40), counterfactual *-taa* occurs directly on the verb in an aspectually unspecified counterfactual, but on an additional auxiliary BE when another aspectual marker occurs on the main verb (Bhatt, 1997).

- (40) a. Present CF – Unspecified (“fake” habitual only)
 agar Ram phal khaa-taa
 if Ram fruit ate-HAB
 “If Ram ate the fruit (CF)...”
- b. Past CF – Perfective (real perfective + “fake” habitual)
 agar Ram-ne phal khaa-yaa ho-taa
 if Ram-ERG fruit ate-PFV be-HAB
 “If Ram had eaten the fruit (CF)...”
- c. Past CF – Habitual (real habitual + “fake” habitual)
 agar Ram phal khaa-taa ho-taa
 if Ram fruit ate-HAB be-HAB

“If Ram had been eating fruit habitually (CF)...”

- d. Past CF – Progressive (real progressive + “fake” habitual)

agar Ram phal khaa rahaa to-taa
if Ram fruit ate PROG be-HAB
“If Ram had been eating the fruit (CF)...”

Of particular interest is the fact that counterfactual *-taa* can co-occur with habitual *-taa*, as in (40c).

In all of these cases, however, habitual *-taa* occurs in place of tense marking: it replaces the past perfective marking in the “unspecified” counterfactual in (40a), and the counterfactual auxiliary occurs in place of the temporal auxiliary in (40b-d). Hindi is thus consistent with an analysis in which counterfactual morphology “overwrites” the temporal specification of T^0 .

A more interesting case can be found in certain varieties of Arabic, illustrated here by Palestinian Arabic.¹³ As in many of the other languages reviewed here, counterfactuals in Arabic are marked by “past” inflection. This can be seen in (41a), where a present-oriented adverb co-occurs with counterfactual “past” morphology on the main verb.¹⁴ In (41b), however, we see that it is possible to express two “layers” of past: temporal past tense is expressed on the main verb, while counterfactual “past” occurs on an auxiliary verb.

- (41) a. Present CF – Perfective (“fake” past only)

iza t̤ileʕ halaʔ. . .
if leave.PAST.PFV now
“If he left now. . .” (Halpert and Karawani, 2011, p, ex))

- b. Past CF – Perfective (real + “fake” past)

iza kanno t̤ileʕ bakkeer. . .
if be.PST leave.PAST.PFV early
“If he had left early. . .” (Halpert and Karawani, 2011, p, ex))

Imperfective aspect involves another “layer” of auxiliary marking. As we saw in 2.3.4.2, the imperfective in Palestinian Arabic has a default present interpretation, and a past-marked auxiliary BE is required for the past imperfective, as shown in (42) (repeated from (13)):

¹³Similar facts appear to obtain in other varieties; see, for example, the discussion of counterfactual auxiliaries in Brustad (2000).

¹⁴I argued in 2.3.4.2 that the Arabic simple past is syntactically marked only for tense, receiving a default perfective interpretation, and that present tense is syntactically unspecified.

- (42) a. b-tuktob
 B-write.IMPF
 ‘She usually writes.’
- b. **kaanat** tuktub
 be.PST write.IMPF
 ‘She used to write.’

I argued in 2.3.4.2 that an imperfective main verb remains below Asp^0 , and is consequently unable to Agree with T^0 for past tense features. It is thus also unable to Agree with C^0 for *counterfactual* past features, and so we find counterfactual past marked on an auxiliary in (43a). In the *past* imperfective counterfactual in (43b), we again find two ‘layers’ of past tense morphology: unlike in the perfective, however, neither of these pasts is marked on the main verb, and both are realized on separate auxiliaries:

- (43) a. Present CF – Imperfective (“fake” past on auxiliary)
- iza kanno b-yitlaʕ bakkeer kul yom...
 if be.PST B-leave.IMPF early every day
 ‘If he were in the habit of leaving early every day...’ (Halpert and Karawani, 2011, p, ex))
- b. Past CF – Imperfective (real + “fake” past = two auxiliaries)
- iza kanno kaan b-yitlaʕ bakkeer kul yom...
 if be.PST be.PST B-leave.IMPF early every day
 ‘If he were in the habit of leaving early every day...’ (Halpert and Karawani, 2011, p, ex))

The fact that two separate instances of “past” – one temporal, one modal – can be stranded in examples such as (43b) requires that Arabic permit two separate instances of [INFL:NON-COIN] to coexist in a single clause.

Given the view that counterfactual inflection is associated with a *different structural position* than temporal inflection, the use of auxiliaries can be easily captured in the framework proposed in chapter 2. They will arise when inflectional features that occur in C^0 are *stranded*; features are *stranded* when they are unable to Agree directly with V^0 .

- (44) *Stranded counterfactual inflection:*

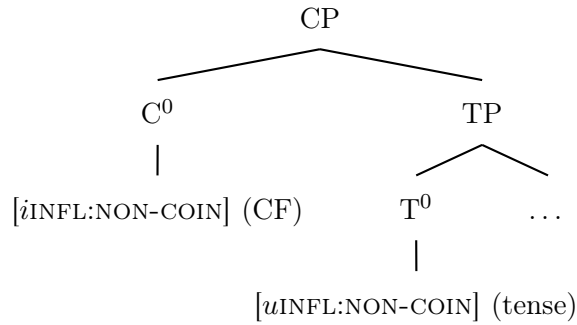

Just as Asp^0 intervenes between T^0 and V^0 in a past imperfective such as (42), then, it will intervene between C^0 and V^0 in a present imperfective counterfactual such as (44b). Similarly, in the past imperfective counterfactual in (44b), T^0 's own features will be stranded on Asp^0 , while C^0 's features will be stranded on T^0 .

In summary, counterfactual auxiliaries fall out automatically as part of the expected typology of counterfactual marking, once we adopt a view of verbal inflection like the one developed in chapter 2 together with the view that counterfactual inflectional features are represented in a structurally different position than their temporal counterparts. Like temporal inflectional features lower in the clause, they can be “stranded” in certain environments, triggering the occurrence of an auxiliary BE.

In languages like English, these features can target – and overwrite – corresponding features on lower heads, resulting in *ambiguity*; the semantics of temporal past may persist, but it is not reflected in surface inflectional morphology.

In languages like Arabic, by contrast, the presence of an already-valued instance of the same feature is *not* a possible target for Agree. As a result, Agree fails, and the inflectional features remain stranded in C^0 .

5.5 Conclusion

The goal of this chapter has been to extend the account of verbal inflection developed in chapter 2 to the patterns of verbal inflection found in counterfactuals.

Counterfactuals are associated with “fake” or “repurposed” inflectional morphology in a wide range of languages. Adopting proposals that this inflection is associated with a higher structural position than its temporal counterparts (Aygen, 2004; Arregui, 2009; Ritter and Wiltschko, 2010; Bjorkman, 2011b), I argued that two phenomena associated with

counterfactuals fall out as a result of the same mechanisms used to derive variation among auxiliary verb constructions in chapter 2. Conditional inversion is the parallel of Agree-triggered verb movement within the inflectional domain, while counterfactual auxiliaries represent the “stranding” of counterfactual inflectional features.

Chapter 6

Conclusion

The central goal of this dissertation has been to argue for an approach to verbal inflection that accommodates a range of auxiliary patterns found in natural language.

The empirical starting point of the dissertation was the division of auxiliary strategies into two basic types: the additive pattern on the one hand, and the overflow pattern on the other. As I argued in chapter 2, it is the overflow pattern, where auxiliary verbs arise only in certain *combinations* of inflectional categories, that requires a syntactic reanalysis of the representation of auxiliary verbs

I argued that the overflow pattern demonstrates that auxiliary verbs occur as a response to stranded inflectional information, inflection that has failed to combine with the main verb. This requires an approach to verbal inflection with three basic components: first, that inflection is introduced separately from the main verb; second, that inflection can fail to combine with the main verb; and third, that inflection that fails to combine with the main verb triggers the occurrence of a default verb BE.

I proposed that these requirements are best implemented in an Agree-based system of verbal inflection, allowing inflection to be manipulated in the form of abstract *features* rather than by head movement. This captures the insight that the manipulation of verbal inflection is constrained by relativized minimality, accounting for how structural factors can prevent inflection from uniting with the main verb. Verbal inflection, however, strongly favours a *reverse* implementation of Agree, in which inflectional information (feature values) can be transferred *downward*, as proposed by an increasing number of authors (Adger, 2003; Baker, 2008; Zeijlstra, 2008, 2010; Haegeman and Lohndal, 2010; Merchant, 2011; Wurmbrand,

2011, a.o.). This formulation of Agree has a number of broader implications, some of which were discussed in section 2.5. In particular, it raises questions in the domain of φ -agreement, which has been widely discussed as a core case of *upward* valuation of features.

Subsequent chapters discussed the implications for this general approach to verbal inflection in a number of domains. Chapter 3 extended the system into the domain of auxiliary HAVE and the phenomenon of auxiliary selection. The existence of alternations between HAVE and BE can be naturally captured, I argued, on the view that auxiliaries other than BE result from the presence of additional featural information in the position in which inflectional features are stranded. I followed Freeze (1992) and Kayne (1993) in proposing that HAVE results from the presence of *prepositional* material in a position that would otherwise have been realized as BE. I argued, however, that perfect HAVE results from a prepositional *feature* that is generated on the perfect aspectual head (Perf^0), linking the use of HAVE in the perfect to the use of verbs of motion or position as temporal and aspectual auxiliaries more generally.

The association of the perfect with a prepositional feature allowed a novel account of auxiliary selection, in which auxiliary HAVE results from the *failure* of this prepositional feature to Agree with some lower element in the clause. This relied on the reverse Agree approach to feature manipulation proposed in chapter 2

Chapter 4 addressed the apparent conflict between the idea that auxiliary BE is a morphological repair for stranded inflectional features, and the similar analyses of DO-support that have been widely accepted since Chomsky (1957). If those analyses of DO-support are correct, we face the question of what determines the insertion of BE in some cases (leading to auxiliary verb constructions), and DO in others. I argued that a broader typological picture of DO-support argues against the view that DO is inserted as a last-resort morphological repair, however, resolving the apparent conflict between the existence of DO-support and the proposed analysis of auxiliary BE. I sketched an alternative analysis of DO-support in which DO realizes v^0 when the latter is not pronounced in the same position as the lexical verb, in response to conflicting linearization requirements imposed by T^0 and the verb.

Finally, chapter 5 extended the Agree-based approach to verbal inflection and auxiliaries into the domain of counterfactuals. I argued that two constructions that have often been discussed as curiosities of counterfactual clauses – conditional inversion and the use of auxiliary verbs to host counterfactual inflection – fall out as a natural consequence of the

system of verbal inflection developed in chapter 2, if we adopt the view that counterfactual inflection is associated with the left periphery.

The overall conclusion of this dissertation is that the view that auxiliary verbs are simply a morphological response to “failures” of the inflectional system – failures in the sense that the syntax does not satisfy the *morphological* requirements of inflectional features – motivates an overall approach to verbal inflection that provides valuable insight in a number of empirical domains. In principle, this should extend more broadly to auxiliary constructions, as discussed in passing at several points in chapter 3 in particular.

Throughout this dissertation it has also been key that inflectional information, in the form of abstract feature values, can be transferred *downward* in the course of the syntactic derivation. This has been implemented in terms of reverse Agree. The availability of such an operation has widespread implications for syntactic theory, some of which have been discussed here. Much work remains to be done investigating the general empirical consequences of this approach.

Bibliography

- Aboh, Enoch O. 2009. Aspects of the Syntax of Kwa: a comparative view. Lecture Notes, African Linguistics School 2009.
- Ackrill, J.L. 1963. *Aristotle's Categories and De interpretatione*. Oxford University Press, USA.
- Adger, David. 2003. *Core Syntax*. Oxford University Press New York.
- Aikhenvald, Alexandra Y., and R. M. W. Dixon. 2007. *Serial verb constructions: a cross-linguistic typology*. Oxford University Press.
- Akmajian, Adrian, Susan M. Steele, and Thomas Wasow. 1979. The category aux in universal grammar. *Linguistic Inquiry* 10:1–64.
- Alexiadou, Artemis, Monika Rathert, and Arnim von Stechow. 2003. Introduction: the modules of perfect constructions. In *Perfect explorations*, vii–xxxviii. Berlin: Mouton de Gruyter.
- Anderson, Gregory D. S. 2006. *Auxiliary verb constructions*. Oxford University Press, USA.
- Arregi, Karlos. 2000. Tense in Basque. Ms. MIT.
- Arregi, Karlos. 2004. The have/be alternation in Basque. Ms. University of Illinois at Urbana Champaign.
- Arregui, Ana. 2004. On the accessibility of possible worlds: the role of tense and aspect. Doctoral Dissertation, University of Massachusetts at Amherst.
- Arregui, Ana. 2009. On similarity in counterfactuals. *Linguistics and Philosophy* 32:245–278.
- Avram, Larisa, and Virginia Hill. 2007. An irrealis be auxiliary in Romanian. In *Split auxiliary systems: a cross-linguistic perspective*, ed. Raúl Aranovich, 47–64. John Benjamins Publishing Company.
- Aygen, Gülşat. 2004. T-to-C and overt marking of Counterfactuals: Syntactic and Semantic Implications. *Harvard Working Papers in Linguistics* 10:1–18.
- Baker, C. L. 1991. The syntax of English not: The limits of core grammar. *Linguistic Inquiry* 22:387–429.
- Baker, Mark. 1985. The mirror principle and morphosyntactic explanation. *Linguistic Inquiry* 16:373–415.

- Baker, Mark, Kyle Johnson, and Ian Roberts. 1989. Passive arguments raised. *Linguistic inquiry* 20:219–251.
- Baker, Mark C. 1988. *Incorporation: A theory of grammatical function changing*. University of Chicago Press.
- Baker, Mark C. 2008. *The syntax of agreement and concord*. Cambridge University Press.
- Baltin, Mark. 2010. Deletion versus pro-forms: An overly simple dichotomy? Ms. New York University, May 2010.
- Béjar, Susana. 2000. Structural markedness in formal features: Deriving interpretability. *Revue québécoise de linguistique* 28:47–72.
- Béjar, Susana, and Milan Rezac. 2009. Cyclic agree. *Linguistic Inquiry* 40:35–73.
- Benincà, Paola, and Cecilia Poletto. 2004. A case of *Do*-support in romance. *Natural Language & Linguistic Theory* 22:51–94.
- Benmamoun, Elabbas. 1999. Arabic morphology: The central role of the imperfective. *Lingua* 108:175–201.
- Benmamoun, Elabbas. 2000. *The feature structure of functional categories: A comparative study of Arabic dialects*. Oxford University Press.
- Benveniste, E. 1968. *Mutations of linguistic categories*. University of Texas Press.
- Bhatt, Rajesh. 1997. Counterfactual morphology in modern indo-aryan languages: Semantic and typological issues. Ms., University of Pennsylvania, Philadelphia, and MIT, Cambridge, MA.
- Bhatt, Rajesh, and Roumyana Pancheva. 2006. Conditionals. In *The Blackwell Companion to Syntax*, ed. Martin Everaert and Henk van Riemsdijk, volume 1, 638–687. Blackwell.
- Bjorkman, Bronwyn M. 2011a. The crosslinguistic defaultness of *be*. In *Proceedings of WCCFL 29: Papers from the Poster Session*, Coyote Working Papers in Linguistics.
- Bjorkman, Bronwyn M. 2011b. The syntax of inverted conditional antecedents. Presentation, *LSA* 2011.
- Bjorkman, Bronwyn M. to appear. Go get, come see: motion verbs, morphological restrictions, and syncretism.
- Bjorkman, Bronwyn M., and Claire Halpert. in prep. In search of (im)perfection: the illusion of counterfactual aspect. Ms. MIT.
- Bobaljik, Jonathan. 1995. Morphosyntax: The syntax of verbal inflection. Doctoral Dissertation, Massachusetts Institute of Technology.
- Bonet, Eulalia. 1991. Morphology after syntax: Pronominal clitics in Romance. Doctoral Dissertation, MIT.
- Borer, Hagit. 2005. *The normal course of events (structuring sense, vol. ii)*. Oxford University Press, Oxford.

- Bruening, Benjamin. 2010. Language-particular syntactic rules and constraints: English locative inversion and *do*-support. *Language* 86:43–84.
- Brustad, Kristen E. 2000. *The syntax of spoken arabic: A comparative study of moroccan, egyptian, syrian, and kuwaiti dialects*. Georgetown University Press.
- Burzio, Luigi. 1986. *Italian syntax: A government-binding approach*. Studies in Natural Language and Linguistic Theory. Springer.
- Bybee, Joan L., Revere D. Perkins, and William Pagliuca. 1994. *The evolution of grammar*. University of Chicago Press.
- Byrne, Francis. 1990. Grammatical relations in a radical creole: Verb complementation in Saramaccan. .
- Carden, Guy, and David Pesetsky. 1977. Double-verb constructions, markedness, and a fake co-ordination. In *Papers from the thirteenth regional meeting of the CLS*, volume 13, 82–92. Chicago, Illinois: CLS.
- Cardinaletti, Anna, and Giuliana Giusti. 2001. "Semi-lexical" motion verbs in Romance and Germanic. In *Semi-lexical categories: The function of content words and the content of function words*, ed. Norbert Corver and Henk C. van Riemsdijk, 371–414. Walter de Gruyter.
- Carnie, Andrew, and Eithne Guilfoyle. 2000. *The syntax of verb initial languages*. USA: Oxford University Press.
- Chiominto, C. 1984. *Lo parla forte della pora ggente*. Roma: Bulzoni.
- Chomsky, Noam. 1957. *Syntactic structures*. The Hague, Mouton.
- Chomsky, Noam. 1986a. *Barriers*. The MIT Press.
- Chomsky, Noam. 1986b. *Knowledge of language: Its nature, origin, and use*. Praeger Publishers.
- Chomsky, Noam. 1991. Some notes on economy of derivation and representation. In *Principles and parameters in comparative grammar*, ed. Robert Freidin, 417–454. Cambridge, MA: MIT Press.
- Chomsky, Noam. 1993. A minimalist program for linguistic theory. In *The View from Building 20: Essays in Linguistics in Honor of Sylvain Bromberger*, ed. Ken Hale and Samuel J. Keyser, 1–52. MIT Press.
- Chomsky, Noam. 1995. *The minimalist program*. Cambridge, MA: MIT Press.
- Chomsky, Noam. 1998. Minimalist inquiries: the framework. *MIT Occasional Papers in Linguistics* 15.
- Chomsky, Noam. 2000. Minimalist inquiries: the framework. In *Step by step: Essays on minimalist syntax in honour of Howard Lasnik*, ed. Roger Martin, David Michaels, and Juan Uriagereka, 89–155. MIT Press.

- Chomsky, Noam. 2001. Derivation by phase. In *Ken Hale: A Life in Language*, ed. Michael Kenstowicz. Cambridge, MA: MIT Press.
- Chomsky, Noam. 2005. On phases. Manuscript, MIT.
- Cinque, Guglielmo. 1999. *Adverbs and functional heads: A cross-linguistic perspective*. Oxford University Press, USA.
- Clarke, S. 2004. Newfoundland english: morphology and syntax. In *A handbook of varieties of english: a multimedia reference tool. morphology and syntax*, ed. B. Kortmann, volume 2, 303. Walter de Gruyter.
- Collins, Chris. 2002. Eliminating labels. In *Derivation and explanation in the minimalist program*, 42–64. Wiley Online Library.
- Comrie, Bernard. 1976. *Aspect: an introduction to the study of verbal aspect and related problems*. Cambridge Textbooks in Linguistics. Cambridge: Cambridge University Press.
- Coon, Jessica, and Omer Preminger. 2011. Towards a unified account of person splits. WCCFL 29.
- Cottell, M. Siobhán. 2003. The syntax of perfective aspect in Hiberno-English. *Belfast working papers in language and linguistics* 16:1–23.
- Cowper, Elizabeth A. 1999. Feature geometry and verbal inflection. *Toronto Working Papers in Linguistics* 17:82–98.
- Cowper, Elizabeth A. 2003. Tense, mood and aspect: A feature-geometric approach. Ms. University of Toronto Online: www.chass.utoronto.ca/cowper/Cowper.TMA2003.pdf.
- Cowper, Elizabeth A. 2005. The geometry of interpretable features: Infl in English and Spanish. *Language* 81:10–46.
- Cowper, Elizabeth A. 2010. Auxiliary Verb Insertion. Handout from ACL/CLA Conference.
- Cowper, Elizabeth A., and Daniel Currie Hall. 2011. Three problems, one solution. Talk given at the 2011 CLA meeting.
- Dahl, Östen. 1985. *Tense and aspect systems*. Oxford: Basil Blackwell.
- Dechaine, Rose-Marie. 1993. Predicates across categories: Towards a category-neutral syntax. Doctoral Dissertation, University of Massachusetts at Amherst.
- Dechaine, Rose-Marie. 1995. One *be*. *Linguistics in the Netherlands* 12:73–88.
- Demirdache, Hamida, and Miryam Uribe-Etxebarria. 2000. The primitives of temporal relations. In *Step by step: Essays on minimalist syntax in honor of Howard Lasnik*, ed. Roger Martin, David Michaels, and Juan Uriagereka. Cambridge, MA: MIT Press.
- Den Besten, Hans. 1983. On the interaction of root transformations and lexical deletive rules. In *On the formal syntax of the Westgermania*, 47–131.
- Den Dikken, Marcel. 1994. Auxiliaries and participles. In *Proceedings of NELS 24*, volume 1, 65–79.

- Dik, Simon. 1983. Auxiliary and copula *be* in a Functional Grammar of English. In *Linguistic categories: auxiliaries and related puzzles*, ed. Frank Heny and Barry Richards, 121–143. Dordrecht: Reidel.
- Dik, Simon. 1987. Copula auxiliarization: how and why? In *Historical development of auxiliaries*, ed. Martin Harris and Paolo Ramat, number 35 in Trends in Linguistics, 53–84. Mouton de Gruyter.
- Doron, Edit. 1999. V-movement and VP-ellipsis. Ms. Hebrew University of Jerusalem.
- Dowty, D. R. 1979. *Word meaning and montague grammar*. Dordrecht: Reidel.
- Ellegård, Alvar. 1953. *The Auxiliary Do: the Establishment and Regulation of its Use in English*, volume 2 of *Gothenburg Studies in English*.. Stockholm, Almqvist, Wiksell: Göteborg.
- Embick, David. 2000. Features, syntax, and categories in the Latin perfect. *Linguistic Inquiry* 31:185–230.
- Embick, David. 2004. On the structure of resultative participles in English. *Linguistic Inquiry* 35:355–392.
- Embick, David, and Rolf Noyer. 2001. Movement operations after syntax. *Linguistic Inquiry* 32:555–595.
- Emonds, Joseph E. 1964. Root and structure-preserving transformations. Doctoral Dissertation, Massachusetts Institute of Technology.
- Emonds, Joseph E. 1978. The verbal complex V'-V in french. *Linguistic Inquiry* 21:49–77.
- Farkas, Donka F. 1993. On the semantics of subjunctive complements. In *Romance languages and modern linguistic theory*, ed. Paul Hirschbühler, 69–105. John Benjamins.
- Fassi Fehri, Abdelkader. 1993. *Issues in the structure of arabic clauses and words*. Dordrecht: Kluwer Academic Publishers.
- Fintel, Kai von, and Sabine Iatridou. 2002. Since *since*. Ms. MIT.
- Fleischman, Suzanne. 1989. Temporal distance: A basic linguistic metaphor. *Studies in language* 13:1–50.
- Freeze, Ray. 1992. Existentials and other locatives. *Language* 68:553–595.
- Giannakidou, Anastasia. 2009. The dependency of the subjunctive revisited: temporal semantics and polarity. *Lingua* 119:1883–1908.
- Giorgi, Alessandra. 2009. Toward a syntax of the subjunctive mood. *Lingua* 119:1837–1858.
- Giorgi, Alessandra, and Fabio Pianesi. 1997. *Tense and aspect: From semantics to morphology*. Oxford University Press, USA.
- Giorgi, Alessandra, and Fabio Pianesi. 2004. Complementizer deletion in italian. In *The Structure of CP and IP. The Cartography of Syntactic Structures*, ed. Luigi Rizzi, volume 2, 190–210. Oxford University Press.

- Goldberg, Lotus M. 2005. Verb-stranding VP ellipsis: A cross-linguistic study. Doctoral Dissertation, McGill University.
- Llinas i Grau, Mireria. 1991. The affix-like status of certain verbal elements. *Catalan Working Papers in Linguistics (CWPL)* 129:129–147.
- Greenberg, Joseph H. 1966. *Language universals: With special reference to feature hierarchies*. The Hague: Mouton & Co.
- Haddican, Bill. 2007a. On *egin*: *do*-support and VP focus in Central and Western Basque. *Natural Language & Linguistic Theory* 25:735–764.
- Haddican, Bill. 2007b. The structural deficiency of verbal pro-forms. *Linguistic inquiry* 38:539–547.
- Haegeman, Liliane, and Terje Lohndal. 2010. Negative concord and (multiple) agree: a case study of West Flemish. *Linguistic Inquiry* 41:181–211.
- Hagstrom, Paul. 1995. Negation, focus, and *do*-support in Korean. *Ms., MIT*.
- Hagstrom, Paul. 1996. *Do*-support in Korean: Evidence for an interpretive morphology. In *Proceedings of SICOOG*.
- Hale, Kenneth. 1969. Papago /čim/. *International Journal of American Linguistics* 35:203.
- Hale, Kenneth. 1986. Notes on world view and semantic categories: Some Walpiri examples. In *Features and Projections*, ed. Muysken and Henk van Riemsdijk, 233–254. Dordrecht: Foris.
- Hale, Kenneth, and Samuel J. Keyser. 1993. On argument structure and the lexical expression of syntactic relations. In *The view from building 20*, 53–109. Cambridge, MA: the MIT Press.
- Halle, Morris. 1990. An approach to morphology. In *Proceedings of NELS 20*. University of Massachusetts, Amherst: GLSA.
- Halle, Morris, and Alec Marantz. 1993. Distributed Morphology and the pieces of inflection. In *The View from Building 20: Essays in Linguistics in Honor of Sylvain Bromberger*, ed. Ken Hale and Samuel J. Keyser. Cambridge, MA: MIT Press.
- Halle, Morris, and Alec Marantz. 1994. Some key features of Distributed Morphology. *MIT Working Papers in Linguistics* 21:275–288.
- Halpert, Claire. under review. Zulu counterfactuals in and out of conditionals. In *Selected proceedings of ACAL 41*. Cascadilla Proceedings Project.
- Halpert, Claire, and Hadil Karawani. 2011. Aspect in counterfactuals from A(rabic) to Z(ulu). Handout, WCCFL 29. University of Arizona, April 22–24, 2011.
- Han, Chung-hye. 2000. *The Structure and Interpretation of Imperatives: Mood and Force in Universal Grammar*. Routledge.
- Han, Chung-hye, and Antony Kroch. 2000. The rise of *do*-support in English: implications for clause structure. In *Proceedings of NELS 30*.

- Harbert, W., and M. Bahloul. 2002. Postverbal subjects in arabic and the theory of agreement. In *Themes in arabic and hebrew syntax*, ed. Jamal Ouhalla and Ur Shlonsky, volume 53 of *Studies in Natural Language and Linguistic Theory*, 45–70. Springer.
- Harley, Heidi. 1995. Subjects, events and licensing. Doctoral Dissertation, Massachusetts Institute of Technology.
- Harley, Heidi, and Rolf Noyer. 1999. Distributed morphology. *Glott International* 4:3–9.
- Harley, Heidi, and Elizabeth Ritter. 2002. Person and number in pronouns: A feature-geometric analysis. *Language* 78:482–526.
- Hartman, Jeremy. 2010. The semantic uniformity of traces. *Linguistic Inquiry* 42.
- Hoekstra, Teun. 1984. *Transitivity: Grammatical relations in government-binding theory*. Dordrecht, Holland; Cinnaminson, NJ, USA: Foris Publications.
- Hoekstra, Teun. 1994. Have as be plus or minus. *Paths towards Universal Grammar: Studies in Honor of Richard Kayne* 199–215.
- Hoekstra, Teun. 1999. Auxiliary selection in Dutch. *Natural Language & Linguistic Theory* 17:67–84.
- Holmberg, A. 1986. Word order and syntactic features in the Scandinavian languages and English. Ms. University of Stockholm, Department of General Linguistics.
- Houser, Michael J., Line Mikkelsen, Ange Strom-Weber, and Maziar Toosarvandani. 2006. Gøre-Support in Danish. Ms, UC Berkeley.
- Houser, Michael J., Line Mikkelsen, and Maziar Toosarvandani. 2010. A defective auxiliary in danish. *Unpublished manuscript, UC Berkeley* .
- Huddleston, Rodney. 1974. Further remarks on the analysis of auxiliaries as main verbs. *Foundations of language* 11:215–229.
- Hyman, Larry M., and Nzama Valinande. 1985. Globality in the Kinande tone system. In *African linguistics*, ed. Didier L. Goyvaerts, volume 6, 239–260. John Benjamins.
- Iatridou, Sabine. 1996. To have and have not. In *Proceedings of WCCFL XIV*. WCCFL.
- Iatridou, Sabine. 2000. The grammatical ingredients of counterfactuality. *Linguistic Inquiry* 31:231–270.
- Iatridou, Sabine. 2009. Some thoughts about the imperfective in counterfactuals. Handout.
- Iatridou, Sabine, Elena Anagnostopoulou, and Roumyana Izvorski. 2003. Observations about the form and meaning of the Perfect. In *Perfect explorations*, ed. Artemis Alexiadou, Monika Rathert, and Arnim von Stechow, volume 2 of *Interface Explorations*, 153–204. Berlin: Mouton de Gruyter.
- Iatridou, Sabine, and David Embick. 1994. Conditional inversion. In *Proceedings of NELS*, volume 24, 189–203.
- Iatridou, Sabine, and Hedde Zeijlstra. 2010. Modals, negation, and polarity. Sinn und Bedeutung 15, Universität des Saarlandes, Saarbrücken, September 9-11.

- Ippolito, Michela. 2002. On the Semantic Composition of Subjunctive Conditionals. Ms. MIT/Tübingen University.
- Ippolito, Michela. 2004. Imperfect modality. In *The syntax of time*, ed. Jacqueline Guéron and Jacqueline Lecarme, number 37 in Current Studies in Linguistics, 359–387. MIT Press.
- Isard, S.D. 1974. What would you have done if...? *Theoretical Linguistics* 1:233–256.
- Jackendoff, Ray S. 1972. *Semantic Interpretation in Generative Grammar*. Cambridge, MA: MIT Press.
- Jaeggli, Osvaldo, and Nina M. Hyams. 1993. On the independence and interdependence of syntactic and morphological properties: English Aspectual *come* and *go*. *Natural Language & Linguistic Theory* 11:313–346.
- Jakobson, Roman. 1939. Signe zéro. In *Mélanges de linguistique offerts à Charles Bally*, 143–152. Georg et Cie. S.A.
- James, Deborah. 1982. Past tense and the hypothetical: A cross-linguistic study. *Studies in language* 6:375–403.
- Jones, Patrick. 2011. Quite simply, everything is complex. Talk given at the 42nd Annual Conference of African Linguistics at the University of Maryland.
- Jouitteau, Mélanie. 2005. La syntaxe comparée du breton. Doctoral Dissertation, Université de Naoned / Nantes.
- Jouitteau, Mélanie. 2010. Post-syntactic excorporation in realizational morphology: Evidence from Breton. LingBuzz/001169, September 2010.
- Kallen, Jeffery L. 1990. The Hiberno-English perfect: grammaticalisation revisited. *Irish university review* 120–136.
- Källgren, G., and E. F. Prince. 1989. Swedish VP-topicalization and Yiddish verb-topicalization. *Nordic Journal of Linguistics* 12:47–58.
- Karawani, Hadil, and Hedde Zeijlstra. 2010. The semantic contribution of the past morpheme in palestinian counterfactuals. Handout, Workshop on Tense and Aspect in Generative Grammar. Lisbon, Portugal, July 1–2, 2010.
- Karlsson, Fred. 1999. *Finnish: an essential grammar*. Routledge.
- Kayne, Richard S. 1989. Null subjects and clitic climbing. In *The null subject parameter*, ed. O. Jaeggli and K. J. Safir, 239–261. Dordrecht: Kluwer Academic Publishers.
- Kayne, Richard S. 1993. Toward a modular theory of auxiliary selection. *Studia Linguistica* 47:3–31.
- Kayne, Richard S., and Jean-Yves Pollock. 1978. Stylistic inversion, successive cyclicity, and Move NP in French. *Linguistic inquiry* 595–621.

- Kitagawa, Yoshihisa. 1986. Subjects in Japanese and English. Doctoral Dissertation, University of Massachusetts at Amherst.
- Klein, W. 1992. The present perfect puzzle. *Language* 525–552.
- Klein, W. 1994. *Time in language*. Routledge.
- Kratzer, Angelika. 1986. Conditionals. In *Papers from the Parasession on Pragmatics and Grammatical Theory, Twenty-Second Regional Meeting of the Chicago Linguistics Society*, volume 2, 1–15. Chicago: University of Chicago.
- Kroch, Antony S. 1985. Function and grammar in the history of English: Periphrastic *do*. *The Ubiquity of metaphor: metaphor in language and thought* 29:133.
- Külmoja, Irina P. 2005. Conditional constructions in Estonian. In *Typology of conditional constructions*, ed. Victor S. Xrakovskij, number 25 in LINCOS Studies in Theoretical Linguistics, chapter 11, 390–415. LINCOS Europa.
- Kusumoto, K. 1999. Tense in embedded contexts. Doctoral Dissertation, University of Massachusetts.
- Laka, Itziar. 1993. The structure of inflection: A case study in X⁰ syntax. In *Generative studies in basque linguistics*, ed. J. I. Hualde and J. Ortiz de Urbina, 21–70. Amsterdam: John Benjamins.
- Landau, Idan. 2006. Chain resolution in hebrew v(p)-fronting. *Syntax* 9:32–66.
- Lasnik, Howard. 1981. Restricting the theory of transformations: A case study. In *Explanation in linguistics: The logical problem of language acquisition*, ed. Norbert Hornstein and David Lightfoot, 152–173. London: Longman.
- Lasnik, Howard. 1995. Verbal morphology: Syntactic structures meets the Minimalist Program. In *Evolution and revolution in linguistic theory: Essays in honor of Carlos Otero*, ed. Héctor Campos and Paula Kempchinsky, 251–275. Washington, D.C.: Georgetown University Press.
- Lechner, Winfried. 2006. An interpretive effect of head movement. *Phases of interpretation* 45–71.
- Ledgeway, Adam. 2000. *A comparative syntax of the dialects of Southern Italy*. Number 33 in Publications of the Philological Society. Blackwell Publishers.
- Legendre, Géraldine. 2007a. A formal typology of person-based auxiliary selection in italo-romance. In *Syntactic Variation: The dialects of Italy*, ed. Roberts D’Alessandro, Adam Ledgeway, and Ian Roberts, 186–200. Cambridge University Press.
- Legendre, Géraldine. 2007b. On the typology of auxiliary selection. *Lingua* 117:1522–1540.
- Levin, Beth, and Malka Rappaport Hovav. 1995. *Unaccusativity: At the Syntax-Lexical Semantics Interface*. MIT Press.
- Levin, L. 1985. Operations on lexical forms: Unaccusative rules in Germanic languages. Doctoral Dissertation, MIT.

- Levinson, Lisa. 2011. Possessive with in germanic: Have and the role of p. *Syntax* .
- Lieber, Rochelle, and Harald Baayen. 1997. A semantic principle of auxiliary selection in dutch. *Natural Language & Linguistic Theory* 15:789–845.
- Lindström, Liina, and Ilona Tragel. 2010. The possessive perfect construction in estonian. *Folia Linguistica* 44:371–400.
- Lødrup, Helge. 1990. VP-Topicalization and the verb *gjøre* in Norwegian. *Working Papers in Scandinavian Syntax* 45:3–12.
- Mahajan, Anoop. 1994. The ergativity parameter: *have-be* alternation, word order and split ergativity. In *Proceedings of NELS*, volume 24, 317–331.
- Mahajan, Anoop. 1997. Universal grammar and the typology of ergative languages. *Studies on Universal Grammar and typological variation* 35–57.
- Manzini, M. Rita, and Leonardo M. Savoia. 2007. *A unification of morphology and syntax: investigations into romance and albanian dialects*. Taylor & Francis.
- Manzini, Maria Rita, and Leonardo M. Savoia. 1998. Clitics and auxiliary choice in italian dialects: Their relevance for the person ergativity split. *Recherches linguistiques de Vincennes* 115–138.
- Masrangellao Latini, G. 1981. Note di morfologia dialettale. *Quaderni di filologia et lingue romane* 3:241–249.
- Matushansky, Ora. 2006. Head movement in linguistic theory. *Linguistic Inquiry* 37:69–109.
- McCawley, James D. 1971. Tense and time reference in english. In *Studies in linguistic semantics*, ed. Charles J. Fillmore and D. Terrence Langendoen, 97–114. Holt, Rinehart and Winston.
- McCloskey, Jim. 1991. Clause structure, ellipsis and proper government in irish. *Lingua* 85:259–302.
- McCloskey, Jim, and Kenneth Hale. 1984. On the syntax of person-number inflection in Modern Irish. *Natural Language & Linguistic Theory* 1:487–533.
- McCoard, R. W. 1978. *The english perfect: tense-choice and pragmatic inferences*. Amsterdam: North-Holland Press.
- McFadden, Thomas. 2007. Auxiliary selection. *Language and Linguistics Compass* 1:674–708.
- McFadden, Thomas, and Artemis Alexiadou. 2005. Counterfactuals and be in the history of English. In *Proceedings of the 24th West Coast Conference on Formal Linguistics*, ed. John Alderete et al., 272–280. Somerville, MA: Cascadilla Proceedings Project.
- McFadden, Thomas, and Artemis Alexiadou. 2008. Counterfactuals and the loss of be in the history of English. *U. Penn Working Papers in Linguistics* 10:2–14.
- Melchers, G. 1992. Dus no heard da last odis – on the use of *be* as a perfective auxiliary in shetland dialect. In *History of englishes: new methods and interpretations in historical linguistics*, ed. Matti Rissanen et al., 602–610. Berlin: Mouton de Gruyter.

- Merchant, Jason. 2011. Aleut case matters. In *Pragmatics and autolexical grammar: In honor of Jerry Sadock*, ed. Etsuyo Yuasa Yuasa, Tista Bagchi, and Katharine P. Beals, 382–411. Amsterdam: John Benjamins.
- Merchant, Jason. in progress. Not all genders are created equal: Evidence from nominal ellipsis in Greek. *Lingua* .
- Milsark, Gary. 1977. Toward an explanation of certain peculiarities of the existential construction in english. *Linguistic Analysis* 3:1–30.
- Mittwoch, A. 1988. Aspects of english aspect: on the interaction of perfect, progressive and durational phrases. *Linguistics and philosophy* 11:203–254.
- Moro, A. 1997. *The raising of predicates*. Cambridge University Press New York.
- Munaro, Nicola. 2002. Splitting up subject clitic-verb inversion. In *Romance languages and linguistic theory 2000*, ed. Claire Beyssade, Reineke Bok-Bennema, Frank Drijkoningen, and Paola Monachesi, volume 232 of *Amsterdam Studies in the Theory and History of Linguistic Science*, 233–252. John Benjamins Publishing Company.
- Munaro, Nicola. 2005. Computational puzzles of conditional clause preposing. In *UG and external systems: language, brain and computation*, ed. Anna Maria Di Sciullo, volume 75 of *Linguistik Aktuell/Linguistics Today*, 73–94. John Benjamins Publishing Company.
- Musan, Renate. 2001. The present perfect in german: Outline of its semantic composition. *Natural Language & Linguistic Theory* 19:355–401.
- Noonan, Michael P. 1992. *A grammar of Lango*. Walter de Gruyter.
- Noyer, Rolf. 1997. *Features, positions and affixes in autonomous morphological structure*. New York: Garland Publishing.
- Nurse, D. 2003. Aspect and tense in bantu languages. In *The bantu languages*. Routledge.
- Nurse, Derek. 2008. *Tense and aspect in Bantu*. USA: Oxford University Press.
- Olsen, Mari B. 1997. *A semantic and pragmatic model of lexical and grammatical aspect*. New York: Garland Publishing.
- Ørsnes, Bjarne. 2011. Non-finite *do*-support in Danish. In *Papers from CSSP 2009*, ed. O. Bonami and P. Cabredo Hofherr, number 8 in Empirical Issues in Syntax and Semantics, 409–434.
- Palmer, Frank R. 1986. *Mood and Modality*. Cambridge Textbooks in Linguistics. Cambridge University Press Cambridge.
- Pancheva, Roumyana. 2003. The aspectual makeup of perfect participles and the interpretations of the perfect. In *Perfect explorations*, ed. Artemis Alexiadou, Monika Rathert, and Arnim von Stechow, 277–306. Berlin: Mouton de Gruyter.
- Pancheva, Roumyana, and Arnim von Stechow. 2004. On the present perfect puzzle. In *Proceedings of NELS 34*, 469–484.

- Parsons, T. 1990. *Events in the semantics of English: A study in subatomic semantics*. MIT Press.
- Partee, Barbara H. 1977. John is easy to please. In *Linguistic structures processing*, ed. A. Zampolli. Holland, Amsterdam.
- Perlmutter, David M. 1978. Impersonal passives and the unaccusative hypothesis. In *Proceedings of the fourth annual meeting of the Berkeley Linguistics Society*, volume 4, 157–89. Berkeley: University of California.
- Perlmutter, David M., and Paul M. Postal. 1984. The 1-advancement exclusiveness law. *Studies in relational grammar* 2:125.
- Pesetsky, David. 1989. Language-particular processes and the Earliness Principle. Ms. MIT.
- Pesetsky, David, and Esther Torrego. 2002. Tense, Case, and the nature of syntactic categories. In *The syntax of time*, ed. Jacqueline Guéron and Jacqueline Lecarme. Cambridge, MA: MIT Press.
- Pesetsky, David, and Esther Torrego. 2006. Probes, goals and syntactic categories. In *Proceedings of the 7th Annual Conference on Psycholinguistics.*, ed. Y. Otsu. Keio University, Japan.
- Pesetsky, David, and Esther Torrego. 2007. The syntax of valuation and the interpretability of features. In *Phrasal and clausal architecture: Syntactic derivation and interpretation. In honor of Joseph E. Emonds*, ed. S. Karimi, V. Samiian, and W. Wilkins, 262–294. Amsterdam: Benjamins.
- Peterson, David A. 2001. Ingush ?a: The Elusive Type 5 Clitic? *Language* 77:144–155.
- Platzack, Christer. 2008. Cross linguistic variation in the realm of support verbs. *Ling-Buzz*/000766.
- Pollock, Jean-Yves. 1989. Verb movement, universal grammar, and the structure of IP. *Linguistic Inquiry* 20:365–424.
- Portner, Paul. 1997. The semantics of mood, complementation, and conversational force. *Natural Language Semantics* 5:167–212.
- Postma, G. 1993. The syntax of the morphological defectivity of be. *HIL manuscripts* 3:31–67.
- Potsdam, Eric. 1998. *Syntactic issues in the English imperative*. Outstanding Dissertations in Linguistics. New York: Garland Publishing.
- Preminger, Omer. 2009. Breaking agreements: Distinguishing agreement and clitic doubling by their failures. *Linguistic Inquiry* 40:619–666.
- Prior, Arthur N. 1967. *Past, present and future*. Oxford, Clarendon.
- Pullum, Geoffrey K. 1990. Constraints on Intransitive Quasi-Serial Verb Constructions in Modern Colloquial English. *Ohio State Working Papers in Linguistics* 39:218–239.
- Pylkkänen, Liina. 2008. *Introducing arguments*. Cambridge, MA: MIT Press.

- Ramchand, Gillian. 1993. *Aspect and argument structure in modern scottish gaelic*. Stanford University.
- Randall, Janet H. 2007. Parameterized auxiliary selection: A fine-grained interaction of features and linking rules. In *Split auxiliary systems: a cross-linguistic perspective*, ed. Raúl Aranovich, 207–235. John Benjamins Publishing Company.
- Rebuschi, G. 1983. A note on focalization in Basque. *Journal of Basque Studies* 4:29–42.
- Reed, Sylvia L. 2011. Multiple perfects in Scottish Gaelic. In *Proceedings of WCCFL XXIX*.
- Reichenbach, Hans. 1947. *Elements of symbolic logic*. Macmillan.
- Richards, Norvin. 2010. *Uttering Trees*. Cambridge, MA: The MIT Press.
- Richards, Norvin. in prep. Tbd. Ms. MIT.
- de Rijk, R. P. G. 2007. *Standard Basque: A progressive grammar*. Cambridge, MA: MIT Press.
- Ritter, Elizabeth, and Heidi Harley. 1998. Sorting out you, me and the rest of the world: A feature-geometric analysis of person and number. Talk presented at GLOW.
- Ritter, Elizabeth, and Martina Wiltschko. 2009. Varieties of INFL: Tense, location, and person. In *Alternatives to Cartography*, ed. Hans Broekhuis, Jeroen van Craenenbroeck, and Henk van Riemsdijk. Berlin, New York: Mouton de Gruyter.
- Ritter, Elizabeth, and Martina Wiltschko. 2010. The composition of INFL: An exploration of tense, tenseless languages and tenseless constructions. *LingBuzz/001078*, July 2010.
- Rivero, María Luisa. 1994. Clause structure and v-movement in the languages of the balkans. *Natural Language & Linguistic Theory* 12:63–120.
- Rizzi, Luigi. 1978. A restructuring rule in Italian syntax. In *Recent transformational studies in European languages*, ed. Samuel J. Keyser, 113–158. Cambridge: MIT Press.
- Rizzi, Luigi. 1982. *Issues in Italian syntax*. Walter de Gruyter.
- Rizzi, Luigi. 1990. *Relativized minimality*. MIT Press.
- Roberts, Ian. 1985. Agreement parameters and the development of english modal auxiliaries. *Natural Language & Linguistic Theory* 3:21–58.
- Roberts, Ian. 1998. Have/be raising, Move F, and procrastinate. *Linguistic Inquiry* 29:113–125.
- Roberts, Ian. 2010. *Agreement and head movement: clitics, incorporation, and defective goals*. The MIT Press.
- Roberts, I.G. 2005. *Principles and parameters in a vso language: A case study in welsh*. Oxford University Press, USA.
- Ross, John Robert. 1967. Constraints on variables in syntax. Doctoral Dissertation, MIT.

- Ross, John Robert. 1969. Auxiliaries as main verbs. *Studies in Philosophical Linguistics* 1:77–102.
- Rothstein, Susan. 1999. Fine-grained structure in the eventuality domain: The semantics of predicative adjective phrases and be. *Natural Language Semantics* 7:347–420.
- Rothstein, Susan. 2004. *Predicates and their subjects*. Springer.
- Roussou, Anna. 2009. In the mood for control. *Lingua* 119:1811–1836.
- Roussou, Anna. 2010. Selecting complementizers. *Lingua* 120:582–603.
- Schafer, Robin. 1995. Negation and verb second in Breton. *Natural Language & Linguistic Theory* 13:135–172.
- Schein, Barry. 2003. Adverbial, descriptive reciprocals. *Philosophical Perspectives* 17:333–367.
- Schlenker, Phillippe. 2004. Conditionals as definite descriptions. *Research on Language & Computation* 2:417–462.
- Schoorlemmer, Erik. 2007. Agree and existential constructions. In *Romance linguistics 2006: selected papers from the 36th Linguistic Symposium on Romance Languages (LSRL), New Brunswick, March 31-April 2, 2006*, 275–288.
- Schütze, Carson T. 2003. When is a verb not a verb? *Nordlyd* 31:400–415.
- Schütze, Carson T. 2004. Synchronic and diachronic microvariation in English *do*. *Lingua* 114:495–516.
- Shopen, Tim. 1971. Caught in the act: An intermediate stage in a would-be historical process providing syntactic evidence for the psychological reality of paradigms. In *Papers from the Seventh Regional Meeting of the CLS*, 254–63. Chicago, Illinois: CLS.
- Silverstein, M. 1986. Hierarchy of features and ergativity. In *Features and projections*, ed. Pieter Muysken and Henk C. van Riemsdijk, volume 25, 163. Walter de Gruyter.
- Smith, Carlota S. 1991. *The parameter of aspect*. Kluwer Academic Press.
- Sorace, Antonella. 2000. Gradients in auxiliary selection with intransitive verbs. *Language* 76:859–890.
- Sorace, Antonella. 2004. Gradience at the lexicon-syntax interface: evidence from auxiliary selection and implications for unaccusativity. In *The unaccusativity puzzle*, ed. Artemis Alexiadou, Elena Anagnostopoulou, and Martin Everaert, 243–268. Oxford University Press, Oxford.
- Sportiche, Dominique. 1988. A theory of floating quantifiers and its corollaries for constituent structure. *Linguistic inquiry* 19:425–449.
- Starke, Michal. 2010. Nanosyntax: A short primer to a new approach to language. *Nordlyd* 36.
- von Stechow, Arnim. 2001. The janus face of aspect. Ms. University of Tübingen.

- Steele, Susan. 1975. Past and irrealis: Just what does it all mean? *International Journal of American Linguistics* 41:200–217.
- Steele, Susan. 1978. *The category aux as a language universal*.
- Steever, Sanford B. 1988. *The serial verb formation in the Dravidian languages*. Motilal Banarsidass Publishers.
- Stowell, Tim. 2008. Where is the past in the perfect. In *Tiempos compuestos y formas verbales complejas*, ed. Ángeles Carrasco Gutierrez, *Linguística Iberoamericana*, 103–118. Madrid, Vervuet.
- Sulkala, Helena, and Merja Karjalainen. 1992. *Finnish*. London: Routledge.
- Szabolcsi, Anna. 1983. The possessor that ran away from home. *The Linguistic Review* 3:89–102.
- Szabolcsi, Anna. 2004. Positive polarity – negative polarity. *Natural Language & Linguistic Theory* 22:409–452.
- Takano, Yuji. 2004. Coordination of verbs and two types of verbal inflection. *Linguistic Inquiry* 35:168–178.
- Tenny, Carol L. 1987. Grammaticalizing aspect and affectedness. Doctoral Dissertation, MIT.
- Tenny, Carol L. 1994. *Aspectual roles and the syntax-semantics interface*. Kluwer Academic Publishers.
- Thoms, Gary. 2010. 'verb floating' and VPE: towards a movement theory of ellipsis licensing. *LingBuzz/001092*, August 2010.
- Torrego, Esther. 2002. Aspect in the prepositional system of Romance. In *Current issues in romance languages*, ed. Teresa Satterfield, Christina Tortora, and Diana Cresti, number 220 in *Current Issues in Linguistic Theory*, 337–357. John Benjamins Publishing Company.
- Travis, Lisa. 1984. Parameters and effects of word order variation. Doctoral Dissertation, MIT.
- Trinh, Tue. 2011. Edges and linearization. Doctoral Dissertation, MIT.
- Turri, C. 1973. *Grammatica del dialetto novarese*. Novara: La Famiglia Nuaresa.
- Tuttle, Edward F. 1986. The spread of *esse* as universal auxiliary in central Italo-Romance. *Medioevo Romanzo* 11:229–287.
- Ulutas, Suleyman. 2006. Conditional clauses and the architecture of the higher functional domain. Ms. Harvard University.
- Ortiz de Urbina, J. 1989. *Parameters in the grammar of basque*. Dordrecht: Foris.
- Van Linden, An, and Jean-Christophe Verstraete. 2008. The nature and origins of counterfactuality in simple clauses: Cross-linguistic evidence. *Journal of Pragmatics* 40:1865–1895.
- Visser, F. Th. 1969. *An historical syntax of the english language*. Brill Academic Publishers.

- Vlach, Frank. 1993. Temporal adverbials, tenses and the perfect. *Linguistics and Philosophy* 16:231–283.
- Washio, Ryuichi. 2004. Auxiliary selection in the East. *Journal of East Asian Linguistics* 13:197–256.
- Wurmbrand, Susi. 2003. *Infinitives: Restructuring and clause structure*. Mouton de Gruyter.
- Wurmbrand, Susi. 2011. Reverse Agree. Lecture Notes. Retrieved from: <http://wurmbrand.uconn.edu/Papers/Agree-and-Merge.pdf>.
- Zanuttini, Raffaella. 1997. *Negation and clausal structure: a comparative study of Romance languages..* Oxford Studies in Comparative Syntax. Oxford University Press.
- Zeijlstra, Hedde. 2008. Negative concord is syntactic agreement. Ms. University of Amsterdam.
- Zeijlstra, Hedde. 2010. There is only one way to agree. Talk given at GLOW 33, Wrocław, Poland.
- Zwicky, Arnold M. 1969. Phonological constraints in syntactic descriptions. *Papers in Linguistics* 1:411–463.