

DESIGN WITH WIND

by

Douglas R. Coonley

S.B.A.D. Massachusetts Institute of Technology
1972

S.B.M. Massachusetts Institute of Technology
1972

SUBMITTED IN PARTIAL FULFILLMENT
OF THE REQUIREMENTS FOR THE
DEGREE OF MASTER OF
ARCHITECTURE
at the
MASSACHUSETTS INSTITUTE OF
TECHNOLOGY
May 1974

Signature of Author
Douglas R. Coonley
Department of Architecture,
10 May 1974

Certified by
Edward Allen
Associate Professor of Architecture
Thesis Supervisor

.....
Imre Halasz
Professor of Architecture
Thesis Supervisor

Accepted by

Chairman, Departmental Committee
on Graduate Students



COMMENT PAGE

One of the primary purposes of this thesis project is to develop and communicate some information. I would very much appreciate your comments on the project. What don't you understand? What is not clear? What might be elaborated upon? What areas might be expanded or reduced? What might be incorrect about anything presented herein? Which parts are most useful? What further work might be done?

Please make notes as you read, or jot things down as you wish. The back of this sheet is self-addressed to me. Please mail it to me with your comments.

Thank you very much.

Sincerely,

Doug Coonley

TABLE OF CONTENTS

	<u>Page</u>
Abstract	4
Thoughts on Thesis Projects	5
Acknowledgements	5
1.0 THE SITUATION	6
1.1 Energy Crisis	7
1.2 Harmony With Nature	7
1.3 Why Consider Wind?	9
1.4 Potential of Wind Energy	12
1.5 Implications of Wind Energy	18
1.6 Integration of Wind Energy	20
2.0 DESIGN WITH WIND	22
2.1 Wind Use History	23
2.2 Wind Flow Around Built Form	26
2.3 Microclimate Around Built Form	33
2.4 Uses For Wind	34
2.5 The Experimental Process	36
2.6 Wind Tunnel Model	38
2.7 Wind Tunnel Tests	40
2.8 Wind Tunnel Test Results	41
2.9 Evaluation of Results	42
FIGURES 1 - 53	49
3.0 COLLECTION AND UTILIZATION OF WIND ENERGY...	102
3.1 Wind Energy Available	103
3.2 Climatic Analysis	105
3.3 Collection and Distribution	106
3.4 Energy Storage	111
3.5 Wind Energy Applications	114
3.6 Wind Architecture	117
3.7 Energy Conservation	117
3.8 Economics and Costs	123

DESIGN WITH WIND

by Douglas R. Coonley

Submitted to the Department of Architecture on 10 May 1974
in partial fulfillment of the requirements for the degree
of Master of Architecture.

ABSTRACT

This project explores the creative use of wind in the design of buildings. Experiments on architectural models were conducted in a wind tunnel. Results indicate that substantial amounts of energy can be provided by incorporating wind turbines into the design of buildings and, simultaneously, that wind flow problems around buildings can be reduced to a minimum and structural wind loads upon buildings can be greatly reduced.

Thesis Supervisors: Edward Allen
Associate Professor of Architecture
Imre Halasz
Professor of Architecture

THOUGHTS ON THESIS PROJECTS

Projects should be fun, interesting, exciting, worthwhile, and useful to the person who does the project, and to others as well. Explore something which you might not be able to explore once out on the job.

Enjoy yourself as much as possible and find out what can and is being learned.

Explain ideas in a logical way so that people can understand. Try not to do everything, but limit yourself and your project so that one can completely grasp and explore what is being said or done. Make certain that the project is readable by you before expecting others to read it.

ACKNOWLEDGEMENTS

My thesis experience has been one of enjoyment, excitement, frustration at times, great joy at other times, much work, and an experience in learning. I would like to take a moment to express my appreciation to the many people who made this project possible: Ed Allen, Bruce Anderson, Imre Halasz Frank Durgin, Oscar Orringer, Sean Wellesley-Miller, Tim Johnson, John Barley, David Gordon Wilson, Ignacio Garabieta, Suzie Coonley, Waclaw Zalewski, Sam Marculongo, Al Shaw, and Fred Merlis.

1.0 THE SITUATION

The situation encompasses an energy crisis, harmonizing with our natural environment, the potential of wind energy, implications for use of wind energy, and the integration of wind energy use into people's lives and ways of living.

Why should wind be considered? ... This is the question which will be approached in this section.

1.0 THE SITUATION

- 1.1 Energy Crisis
- 1.2 Harmony With Nature
- 1.3 Why Consider Wind?
- 1.4 Potential of Wind Energy
- 1.5 Implications of Wind Energy
- 1.6 Integration of Wind Energy

1.0 THE SITUATION

1.1 ENERGY CRISIS

We know an energy crisis exists, so I won't belabor the issue. Alternative sources of energy are being explored. Winds are constantly regenerated in the earth's atmosphere. Wind seems to be an alternate source of energy worth examining.

1.2 HARMONY WITH NATURE

Nature makes certain that there is a place for each input and output of each participant in nature. Interacting, recycle loops are the key. People seem to be destroying the recycle loops they are involved with. We can revitalize the loops if we carefully evaluate them and try to understand the role we play.

Wind energy is the subject of this project. The hope is to explore possibilities for the use of wind energy to help relieve the load on other energy sources which are less harmonious with nature (e.g., defacing, polluting, exhausting, radiation).

People should understand how they use energy and how much they use. Energy encompasses all things: living and dormant. People must use energy carefully, without waste; and they must use it wisely and for beneficial purposes. People should take a lesson from other creatures around them. Creatures eat only what is required; they use natural materials for their homes; they use their bodies for trans-

port; they do not pollute or destroy places needlessly, but rather, they leave natural fertilizer or useful work behind; they do not waste energy just because it is there. Man is a creature, yet he has persisted in destroying his environment and himself in the process. Has man progressed from careful, respectful use of energy to careless, disrespectful use of energy simply because energy exists?!

All men are not responsible for the careless use of energy. Many people use energy carefully and with respect; they are thankful for what they have and are very careful about how they use energy. All men are responsible for the careful use of energy. Everyone should know how much energy he is consuming, both usefully and wastefully. Then, perhaps, we could make full use of the energy capabilities allowed us.

People use energy in many places: food, materials, labor, transport, work, heat, cooking, clothing, cooling, industry. People receive energy from many places: (sun)wind, wood, atoms, water, fossil fuels (coal, oil, and gas). Some sources of energy like fossil fuels were used more frequently than others because they were easier to get and to use. These sources were used unwisely and are now dwindling. We must explore some alternate sources of energy. Wind is an alternate source of energy worth exploring.

1.3 WHY CONSIDER WIND?

How It Came About

(a poem)

Feeling it every day
fighting against it
dodging it

FLOWING WITH IT
(Griping about it)

running to get out of it

knocking
you
down

picking you up Cooling you off/Warming you up

a breath of fresh air

DESIGNING against it BUILDING against it
THINKING about it

dismissing it with little good thought

COMING FROM THE SUN

Br
ing
ing
gn
ra
in
Bringing warmth

Bringing cool

CURIOUS HOW WE TREAT IT

Always about

Helping out

(causing problems) --

When treated with respect

A good friend --

To know and respect

Always returning --

To give another chance

HOW CAN WE KNOW ?

WHEN SHALL WE LEARN

DESIGN WITH WIND?

AND NOT WITHOUT

INTRODUCTION TO THE STUDY OF WIND

The use of wind energy has been seriously hampered because a large investment in machinery is required, giving only a small energy output in return.

Wind collector output is a function of wind velocity cubed (V^3). Thus, an increase in wind velocity will greatly increase the energy output of any wind collector.

This project shall explore some of the possibilities for locally increasing wind velocity in an effort to insure and produce a larger return from any investment in wind collector systems.

High buildings are accepted as wind problem makers, resulting in additional structural loads, unusable pedestrian space, undesirable effects on people and buildings nearby, and sometimes self-destruction of the building itself.

This project shall explore some of the ways to creatively deal with wind flow disturbances caused by buildings and the effect of these disturbances on the surrounding area.

Wind power may help to supply clean, useful energy if we study wind, work with wind, and try to understand it more fully. Perhaps we will even gain a better understanding of ourselves and our relation to the environment. Wind needs

to be examined carefully and used to its full potential as an aid to built form and as an energy source.

WHY STUDY WIND AND BUILT FORM?

In an effort to better understand how to design with the wind instead of against the wind, as is commonly the case, this project offers some suggestions. Wind and built form should be studied together for the benefit of the environment, nature (wind), and man himself. A joint study would also establish guidelines so that other people might be able to design with the wind. Thus, one could understand what might happen to the microclimate around a built space before it was built, instead of after the built form was completed and unexpected problems had arisen; examples are the M.I.T. Green Building and the John Hancock Building in Boston. One could determine the effect of built form upon the wind and the effect of the wind upon the built form. Finally, it would be to one's advantage to study wind and built form in order to determine whether or not built form could enhance the velocity of the wind in a predictable way and, thus, whether or not more energy could be extracted from the wind by carefully placing wind collectors in the built form.

1.4 POTENTIAL OF WIND ENERGY

"Wind power is by far the most efficient way to recapture solar power."

Buckminster Fuller, 1972

"Wind is capable of supplying 19% of the predicted annual electricity requirements by the year 2000."

1972 NSF/NASA Solar Energy Panel

The potential of wind energy might be more easily understood if we could quantify the factors affecting the use of wind energy. For example, let us use one year as our basis for estimation:

A SHORT FEASIBILITY STUDY

What we need to know in order to make an estimate of the potential of wind energy is:

- (1) How much energy is used for each person over the period in question of one year?
- (2) For what purposes is the energy used?
- (3) To how many people is energy being supplied?
- (4) How many hours per year can our collector be expected to function?
- (5) What is the average monthly wind velocity at the building site?
- (6) How much of a wind velocity increase can we create through the use of built form?
- (7) How much of the wind's energy is available for our use?

Let's see how wind energy looks as a source of energy ...

(1) Energy consumption

Energy consumption per person for the year 1972 was:
350,000,000.0 B.T.U. Multiplying by 1.0 KWHR/3500 B.T.U.,
we get 100,000 KWHR/person/year. Total energy consumption
per person per year in the United States in 1972 was:
100,000 KWHR/person/yr. (From Hottel, New Energy Technology)

(2) Breakdown of Energy Consumption

Energy consumption for 1972 falls into five major areas:

<u>AREA</u>	<u>PERCENT</u>	<u>KWHR/PERSON/YEAR</u>
Industry	30%	30,000.
Transport	25%	25,000.
Utilities, Electricity	25%	25,000.
Commercial	10%	10,000.
Domestic	10%	10,000.
<hr/>		
TOTAL Consumption	100%	100,000.

(From Hottel, New Energy Technology)

(3) Energy Needs

Let us supply energy for 2,000 people working in a 30-story
commercial office building. (24 floors, 80 feet by 240 feet
by 12.5 feet high = 460,000 square feet total floor area and
24 x 12.5 ft. = 300 ft. = 30 stories. Our total energy needs:
2,000 people x 10,000 KWHR/person/year = 20,000,000.0 KWHR/yr.

(4) Collection Period

There are 8,760 hours in one year, but let us assume that
we can only produce wind energy for 8,000 hours per year,

storing extra energy for use when it is needed and spreading out the load. Our wind collector capacity becomes 20,000,000.0 KWHR/year x year/8,000 hours or 2,500 KW capacity required.

(5) Average Monthly Wind Velocity

Our site is near Boston, Massachusetts where the average monthly wind velocity at 100 feet above the ground is about 15 miles per hour or 22 feet per second.

(6) Wind Velocity Increase

Let us assume that we can double the wind velocity by creative use of our built form. Our average monthly wind velocity now becomes 30 miles per hour or 44 feet per second. We have two basic collectors to choose from - a propellor rotor or a drag rotor. Power capacity will depend upon the wind velocity and the area swept by the collector.

<u>POWER CAPACITY</u>	<u>ROTOR TYPE</u>
$KW = 2.0 \times 10^{-6} R^2 V^3$ $R = \text{ft.}, V = \text{ft./sec.}$	Propellor
$KW = 7.3 \times 10^{-4} R^2 V^3$ $R = \text{m}, V = \text{m/sec.}$	Propellor
$KW = 3.2 \times 10^{-7} A V^3$ $A = \text{ft.}^2, V = \text{ft./sec.}$	Drag
$KW = 1.2 \times 10^{-5} A V^3$ $A = \text{m}^2, V = \text{m/sec}$	Drag

Actual energy produced by the collector will be twice the amount calculated from the equations above using V_{average} . Let us use a propellor type rotor and assume that we can orient our rotor into the wind. Now our power capacity

becomes $KW = 4.0 \times 10^{-6} R^2 V^3$, where, $R = \text{ft.}$, $V = \text{ft./sec.}$

Now we have the necessary information to find out how many wind collectors we will need to supply energy for the 2,000 people working in our commercial office building.

Power capacity required is 2,500 KW.

Power capacity available is $KW = 4.0 \times 10^{-6} R^2 V^3$ where

$R = \text{ft.}$ and $V = \text{ft./sec.}$

Wind velocity available is 44 ft./sec.

We now have:

$$2,500.0 = 4.0 \times 10^{-6} \times R^2 \times 44^3. \text{ Giving}$$

$$R^2 = 2,500. \times 10^6 / 4.0 \times 85,000$$

$$= 7,350$$

$$R = 86 \text{ feet.}$$

We would need a single propellor turbine of 86 feet in radius or 172 feet in diameter to produce the power for the 2,000 people who work in our building. That is a large turbine to build and take care of, so we might wish to use smaller collectors. We would need 4 collectors of 43 feet in radius (86 feet in diameter) or 16 collectors of 21.5 feet in radius (43 feet in diameter) or 64 collectors measuring 10.75 feet in radius (22 feet in diameter). We can construct a chart showing how many wind collectors of the propellor type we would need to supply all of the energy used by our office building.

COLLECTOR SIZE (Diameter)	NO. OF COLLECTORS	PEOPLE SUPPLIED	ENERGY OUTPUT/YR.
180.0 feet	1	2,000	20,000,000 KWHR
90.0 feet	4	"	"
45.0 feet	16	"	"
22.5 feet	64	"	"

We can construct a chart showing the number and size of the collectors required to supply other uses as well as commercial uses.

USE	PEOPLE SUPPLIED	COLLECTOR'S SIZE (diam.)	NUMBER	ENERGY KWHR/YR.	% TOTAL
Industry	1000.	45 foot	48	30 million	30
Transport	1000.	"	40	25 million	25
Utilities	1000.	"	40	25 million	25
Domestic	1000.	"	16	10 million	10
Commercial	1000.	"	16	10 million	10

Sixteen 45-foot diameter wind turbines would occupy about eight floors of our office building. These turbines could produce all of the energy required to satisfy the requirements of the building.

Reduction of energy consumption, by 50%, seems possible, but only with careful design and construction of the building. Our building could then be powered by eight 45-foot diameter wind turbines. The potential for wind energy as an alternate source of energy seems quite promising... but you may decide for yourself!

Advantages and disadvantages for use of wind energy will now be discussed.

ADVANTAGES OF WIND USE:

Winds are constantly regenerated in the atmosphere.

Wind is a clean source of energy - non-polluting and Naturally occurring; wind blows everywhere.

Wind energy increases as the cube of the velocity;

doubling the velocity gives eight times the energy.

Wind energy can provide a variety of useful services - ventilation, cooling, mechanical energy, electrical energy.

People can feel wind directly each day.

Wind is predictable over long periods of time (season, years...)

DISADVANTAGES OF WIND USE:

Wind is unpredictable over short periods. Direction and velocity are uncertain.

Wind collectors and storage devices require the use of energy to make and to install.

Storage devices and auxiliary energy sources are required for use when wind is blowing, or when wind is blowing in the wrong direction or with too much or too little power to properly activate the collectors.

Wind doesn't blow everywhere in the world with adequate velocity to activate collectors.

Wind flow may cause damage to built form or it may inhibit beings from using certain places.(e.g. birds).

Wind collecting devices make noise and vibrate when activated.

1.5 IMPLICATIONS OF WIND ENERGY

ENERGY USAGE:

Each person uses about 10^5 KWHR of energy each year. This includes all services: industry (30%), transport(25%), utilities (25%), commercial (10%), and domestic (10%).

CONSERVATION:

Wind does not blow constantly nor does it blow regularly. Therefore, we must be very careful and fully aware of our energy needs and of our use of energy if we are to move toward the use of wind energy.

Wind energy is a direct source of energy. We can feel wind and sense wind directly. Each person is in intimate contact with wind (or its lack!) each day and can easily respond to the given wind situation. A person who depends on coal, gas, oil, or electricity for power does not and cannot respond directly to the energy situation each day. People cannot assess the supply of an indirect resource nor can they evaluate the misuse of that resource.

Wind energy use would require that people cut down on their use of energy at home, at work, and at play. People must become more careful of what energy they use, of how much they use, of how it is used, and of how it affects other participants. Changes of "lifestyle" might have to occur, but this could be a change for the better.

It might be possible to cut our energy consumption by 50% (in half!) simply by being careful of the energy we use. (Turning out unnecessary lights, devices; reducing room

temperature to more healthy levels - using public transportation, biking, walking instead of driving, forming car pools.) Conventional (coal, gas, oil, electricity) energy appears to be very inexpensive. The truth is that many other hidden expenses necessarily accompany conventional energy sources. These 'expenses' include pollution, defacing of landscapes, thermal buildup, destruction of water resources, unsightly built forms, destruction of beaches, oil spills, and silting in of rivers which have been dammed up for hydroelectric power .

DESIGN:

People must become acquainted with wind and its behavior. Then and only then will people be able to skillfully and practically design with wind. Built form must respond to the wind and its behavior. Wind must be treated as a friend and not as a foe. We must design with wind and not against wind. Re-examination of how we use energy, how much energy we need to use, and now we can utilize our resources more effectively and in harmony with Nature must be the first step. People may have to lower their living standards in order to conserve and protect our resources. Money cannot grow trees (or on them, as the old cliché goes!) or replenish landscapes, or remove pollution, or bring oceans back to life, or remove garbage and sewage from rivers, or remove thermal pollution, and the list could continue. Only people interested and knowledgeable of the way Nature works

can begin to achieve such goals.

1.6 INTEGRATION OF WIND ENERGY

WAYS OF LIVING

People must reduce their consumption of energy by using it carefully, sparingly, and by treating all resources with the utmost respect. People must become familiar with the way natural systems work and with how people (being part of a large and important natural system) affect the systems they are a part of. Only then can people interact with the environment and actively participate in it. People will then be able to utilize resources within the environment, always being careful to replace whatever is used.

DESIGN

People must understand the natural systems which are always at work in the environment. People must respect the ways of nature, the needs of people and beings, and the needs of Nature whenever they are designing, building, living, working, or playing. Greater respect must be given to natural systems (of which man is an important part) and to the way built form affects natural environmental systems both short term and long term. People must design with wind, and not against it. Wind has much to offer us, yet we have failed to respond to its offer. We view wind as a problem maker.

Built form must respond to the wind as it should respond to

people: carefully, suggestively, helpfully, happily, respectfully, willingly, and easily. Built form must respond differently in different climates and situations. This would, of course, make the enclosed, envelope-type, block-form building unnatural, undesirable, unforgiveable, and actually unthinkable. Built form must not turn away from Nature but must open up to the vast capabilities of Nature. Built form, as we know it today, may change drastically or unnoticeably, depending upon how well designers have responded to wind (Nature) in each area. Built form may choose to respect wind and its ways, or built form may utilize the capabilities of wind in its design and form. Designers must understand wind, its ways, when, how, why, and where it flows. Built form must be tested beforehand to be certain that the built form will respond to wind in the way it is naturally designed to respond. Respect for beings (people, plants, animals) and other built forms must always be insured.

WIND ENERGY COLLECTION AND STORAGE

Wind energy collection and storage methods must be developed and tested. Collection methods must be evaluated with respect to their effect upon beings, built form, and resource supplies.

2.0 DESIGN WITH WIND

This section, DESIGN WITH WIND, includes the history of wind use, wind flow around built form, microclimate around built form and uses for wind, wind tunnel model design and construction. Also, wind tunnel tests shall be described and results evaluated for use by designers.

2.0 DESIGN WITH WIND

- 2.1 Wind Use History
- 2.2 Wind Flow Around Built Form
- 2.3 Microclimate Around Built Form
- 2.4 Uses For Wind
- 2.5 The Experimental Process
- 2.6 Wind Tunnel Model
- 2.7 Wind Tunnel Tests
- 2.8 Wind Tunnel Test Results
- 2.9 Evaluation of Results

2.1 WIND USE HISTORY

<u>DATE</u>	<u>USE</u>	<u>LOCATION</u>	<u>AXIS</u>	<u>SUPPORT</u>	<u>COMMENTS</u>
Long ago	ventilation cooling	World	-	shelter	-
644AD	grinding	Persia	V	building	open turbine
915AD	grinding	Persia	V	building	ducted turbine
1000	irrigation	China	V	free standing	feathering blades
1000	grinding	Crimea	V	building	"
1180	grinding	France	H	post	4 sail blades covered with cloth
1187	grinding	England	H	post	
1200	grinding	Europe	H	post	
1250	grinding	Australia	H	building	triangular cloth
		Iberia	"	"	sails on spars,
		Azores	"	"	8-12 sails
		Mediterranean	"	"	
		Greece	"	"	
		Turkey	"	"	
1420	grinding	England	H	building	
		France	"	"	
		U.S.A.	"	"	
1430	drainage	Holland	I	open	water pump
1450	drainage	Holland	H	building	water pump
1600	drainage	Europe	H	building	water pump
1750	sawing oil press paper-making hammer	Africa	H	building	mechanical
		Holland	"	"	
		& U.S.A.	"	"	devices
			"	"	
1772		Scotland			'spring sail' - shutter adjusting mechanism invented - by Andrew Meikle
1775		England			'fantail' automatic orientation device invented - Edmond Lee was inventor

DATE	USE	LOCATION	AXIS	SUPPORT	COMMENTS
1787		England			Centrifugal governing device introduced by Thomas Mead
1789		England			'roller blind' - remote control sails invented by Stephen Hooper
1807		England			'patent sail' - remote control shutters on blades invented by Sir William Cubitt
1854	pump	U.S.A.	H	tower	annular sails
1860	pump	England			air brakes applied to 'patent sails' - R. Catchpole
1890	electric	Denmark	H	tower	patent sails and twin fantails
1900	electric	Holland	H	building	adapted corn mills
1920		France			three blade airfoil experiments - G. Darrieus
1927		Netherlands			application of airfoils leading edges of blades - A.J. Dekker
1931	electric	Crimea	H	tower	3-blade airfoil
1933		Finland	V		savonius rotor invented by J. Savonius
1940	electric	U.S.A.	H	tower	Grandpa's Knob, Rutland, Vt. 2-blade airfoil
1950	electric	England France Russia	H	tower	3-blade airfoil

<u>DATE</u>	<u>USE</u>	<u>LOCATION</u>	<u>AXIS</u>	<u>SUPPORT</u>	<u>COMMENTS</u>
1955	electric	Denmark	H	tower	3-blade airfoil with bow- sprit guy support - J. Juul

KEY: H = horizontal
V = vertical
I = inclined

2.2 WIND FLOW AROUND BUILT FORM

Objects always obstruct the flow of wind. Problems arise because we often cannot predict the ways in which things will obstruct the flow of wind. This section will try to explore some of the predictable ways in which wind flow is changed by built form. Consult figures 1-4, § 50 on pages 49-52, § 98.

The figures show air flow around the built form. These drawings may be used as guides for design, but wind tunnel tests should be made whenever there is a question concerning the flow around a specific building design.

Key to Figures

M = Main stream flow -smooth linear air motion

V = Vortex flow - tight, fast spiral air motion

E = Eddy flow - loose, slow spiral air motion

WIND FLOW GUIDELINES (for figures mentioned above)

- (1) Built form obstructs the flow of wind.
- (2) Velocity increases around all edges of built form.
- (3) Mainstream flow is diverted around built form.
- (4) Large downwash vortex occurs at base of building on windward side.
- (5) Large lazy eddy- forms on leeward side of building over the whole building height.
- (6) Rising vortices form around sharp corners of buildings.

- (7) Center moving vortex occurs at top edge of form on windward side.
- (8) Small eddies form on sides of built form
- (9) Large eddies form near ground on leeward side of built form.
- (10) Sharp corners cause high velocities and flow separation.
- (11) High rise form causes increased velocity near ground and acceleration near windward corners, Vortices from leeward corners and gusty conditions develop. Shear layers between fast and slow moving air cause gusts of wind.
- (12) Suction of air from rising vortices draws air from all directions at ground level - results in strong winds near ground, normal or opposite to free wind and reinforcing downwash on windward face.
- (13) Deflection of glazing occurs due to high negative and positive wind pressure on glass.
- (14) Noise through cracks and rain forced through cracks by increased negative and positive pressures.

RECOMMENDATIONS (consult Figures *5-8* pages *53-56.*)

- (1) Move away from smooth exteriors on built form.
- (2) Break up exterior surface of built form to help break up vortices or perhaps keep them from forming.
- (3) Vertical deflectors help stop increased flow around corners which cause vortices and eddies to form.

- (4) Provision for covered walkways and protection near the ground.
- (5) Use of perforated wind deflectors and screens in place of solid ones to reduce wind velocities and protect places for people and beings.
- (6) Enclose upper level balconies to provide usable spaces instead of unusable windy balconies.
- (7) Utilize increased velocities for power by careful placement of slots and wind turbines.
- (8) Be careful of the color of materials; they may absorb or reflect heat, causing thermal spirals.
- (9) Horizontal deflectors break up vertical flows. Vertical deflectors break up horizontal flows.

WIND FLOW PROBLEM SPOTS (consult Figures 1-4)

- (1) Shed vortices form around the corners of built form.
- (2) Thermal spirals may increase vortex flow.
- (3) Thermal differences may initiate adverse flow near built form.
- (4) Absorbancy and reflectivity of built form is critical.
- (5) Eddies around built form result in gusty conditions and air flow direction changes.
- (6) A downwash occurs on the windward side of the building.
- (7) Increased velocities over top and around sides of built form, as air flows around it.
- (8) Cooling of shaded areas near high built form.
- (9) Heating of adjacent areas near built form with large

glass areas.

- (10) Deflection of glass due to wind pressures (negative or positive).
- (11) Deflection of built form due to wind pressures.
- (12) Downwind deposits (flow) of odors, smoke, and discharge from built form.

DETERMINATION OF WIND FLOW AROUND BUILT FORM

Full scale observations are the best and most reliable source of information. Wind tunnel studies are useful during the design of built form. Careful modeling of nearby forms and of the environment is critical and required. Three-dimensional presentation of information is critical to the understanding of wind flow around built form.

ENVIRONMENTAL AIRFLOW PROBLEMS

PEDESTRIAN LEVELS

High wind velocities and turbulence blow people and things about, interrupt activities, carry airborne dirt and debris, lift clothing, and create motion of the built form, often affecting the physical well-being of people in the building.

BUILDING PROBLEMS

- (1) Difficulty in operating entrance doors due to adverse pressure conditions.
- (2) Ineffectiveness of protective canopies, screens, and awnings.

- (3) Adverse pressure effects on air conditioning and ventilation intakes and exhausts.
- (4) Pollution of cooling towers by corrosive exhausts from adjacent incinerator and furnace flues.
- (5) Safety of built form maintenance staff (window cleaners, janitors, surface cleaners).
- (6) Weatherproofing of joints in materials and window frames.
- (7) Wind noise from leaky windows or attachments to built form (exterior structure, signs, sun control devices).
- (8) Sufficient compression of gaskets around openings is required for an effective seal.
- (9) Cam type locking devices can provide the necessary compression of gaskets around openings.
- (10) Accumulation of rain water in sashes and frames due to high wind velocity and pressure. This can leak into the space inside.
- (11) Larger and varying diameter drain holes along each frame have proven useful in solving water problems. Countersinking inside of hole helps to minimize surface tension resistance to the draining of water.

EFFECTS UPON SURROUNDINGS

- (1) Spray from nearby water bodies (fountains, streams, ponds, lakes, oceans).
- (2) Drying out of planting beds and potted plants in

wind swept areas.

- (3) Wind damage to plants and trees.
- (4) Buffeting of beings and objects on nearby walkways and roadways by shed vortices.
- (5) Increased wave action on adjacent beaches.

SOLVING ENVIRONMENTAL AIRFLOW PROBLEMS

Effects of Surface Roughness

Reduced intensity of the attached airflow results when the roughness of built form surfaces is increased.

Roughness types: (prominent)

Horizontal projections

Vertical projections

Egg crate projection (horizontal and vertical)

45° sloping continuous sun hood

(Consult Figures 5-8)

These reduce rate of flow across built form surfaces, resulting in less intense flow in leeward eddies. Shed vortices at windward edges are dramatically reduced. Reduction in velocities of 40% are attainable.

Projection Size

Surface roughness becomes effective with projections of 2 ft. 6 inches (30 inches, 0.75 m, 750 mm). Effectiveness begins with projection depth of 2 ft. 6 inches. Effectiveness increases with depths greater than 2 ft. 6 inches.

Projecting elements usually correspond to floor levels and

structural spacings or minor subdivisions of these dimensions.

Projections on Built Surfaces:

- (1) Reduce overall air flow problems.
- (2) Increase local air flow disturbances around projections which may be small enough not to cause added problems.
- (3) Increase surface area of built form.
- (4) Increase potential heat loss and heat gain.
- (5) Require added insulation to counteract added heat loss and gain.
- (6) Increase or reduce structure required to support added projections depending upon structural system.
- (7) Increase the potential for people to interact with the natural environment by being able to sense the environment, respond to the environment, or act within the environment.
- (8) Reduce the potential for people to put the natural environment aside by not being able to interact with it.

OVERALL EFFECT OF ROUGH SURFACES

Rough surfaces generate an attached blanket of turbulent air around built form. The turbulent blanket of air, combined with building shape, forms a more streamlined obstruction to air flow. Overall disturbances to air flow are reduced due to streamlining. The turbulent blanket of air contains numerous small eddy flows which concurrently dissipate energy and distribute energy more evenly over the surface of the building. (Source: Anysley, "Wind

Flow Around Buildings".)

2.3 MICROCLIMATE AROUND BUILT FORM

SUNLIGHT (Consult Figure 9 page 57.)

- North side shaded for most of day; except for mornings and evenings from late Spring to early Fall.
- East side shaded in afternoon.
- West side shaded in morning.
- South side receives direct sunlight every day.
- East side receives direct sunlight only in early part of day.
- West side receives direct sunlight only in late part of day.
- North side receives direct sunlight only in very early and very late part of day from late Spring to early Fall.

TEMPERATURE

- North side permanently underheated (cool to cold).
- East side cool in late day.
- South side permanently overheated (warm to hot).
- West side cool in early day.

WIND

- Velocity increases around base of built form, around edges, and top.
- Downwash on windward face of built form.
- Vortices form at sharp corners and near ground surface.

FACTORS IN WIND FLOW

- Barriers, Partial barriers, Pressure differences, Temperature differences.

HEAT FLOW

Everything absorbs and reflects light in differing amounts. Bodies which absorb a large amount (dark bodies) may heat up and reradiate. Bodies which reflect a large amount (light bodies) do not heat up as much. Built form can absorb and/or reflect light. Dark surfaces absorb light and reradiate energy in the form of heat. Heat is transferred to the air nearby. The warmed air rises and may contribute to vortex spirals rising around built form. Areas around built form will contribute heat as well. Dark surfaces will absorb sunlight and reradiate heat. Light surfaces will reflect light toward and into the built form.

2.4 USES FOR WIND

Built form is divided into five major areas of energy use:

<u>USE</u>	<u>% TOTAL</u>
Industrial	30%
Transport	25%
Utilities	25%
Domestic	10%
Commercial	10%

CURRENT USES FOR WIND

Current uses for wind include ventilation and cooling, for all densities of built form; standby energy supply for almost no built forms; main energy supply for a very small number of domestic and utilities built forms. Density of built form where wind energy is used or might be used will be indicated for each of the five major areas of use:

L = low density; 0-4 people/acre

M = medium density; 5-100 people/acre

H = high density; 100 - people/acre

<u>USES FOR WIND</u>	<u>CURRENT</u>	<u>POTENTIAL</u>
Ventilation		
Domestic	All Densities	All Densities
Commercial	"	"
Industrial	"	"
Transport	"	"
Utilities	"	"
Cooling		
Domestic	All Densities	All Densities
Commercial	"	"
Industrial	"	"
Transport	"	"
Utilities	"	"
Standby Energy Supply		
Domestic	L	All
Commercial	L	L and H
Industrial	L	All
Transport	L	All
Utilities	L	All
Main Energy Supply		
Domestic	L	All
Commercial	L	All
Industrial	L	L and H
Transport	L	L
Utilities	L	L and H

POTENTIAL USES FOR WIND

Potential uses include all current uses for wind but expand the application to areas which are now unattainable due to low "apparent" cost costs of fossil fuel based energy.

Low densities are extremely promising where adequate space for wind collectors and careful placement of built form can be achieved. Wind collectors can experience a maximum of wind flow over their blades; without hindrance from other forms nearby, thus allowing collectors to be located near the ground or above the built form. Height above ground is sometimes difficult to achieve.

Medium densities are less promising because built form occurs at a closer spacing, resulting in disturbance of air flow from built forms nearby. Medium density situations do not get high enough to experience the higher wind velocities and more constant winds found high above the ground surface.

High densities are very promising because built form can get high enough to experience higher wind velocities and more constant wind flow. Potential for all densities can be enhanced by the use of built form to increase wind velocities in the immediate area of the wind collector.

2.5 THE EXPERIMENTAL PROCESS

Given:

- A proposed built form, 300 feet high (100 m), 240 feet

wide (80 m), and 40 to 80 feet deep (12 to 24 m).

- Support towers representing mechanical shafts, elevators, exit stairways, and support structure.
- Urban context being the Boston area with spaces to be provided for commercial use, parking, office, and homes.

Find:

Promising places to locate wind collectors to supply energy. Built forms best suited to provide wind energy for collection and use. And the effect that the office building will have on the microclimate, especially where people will be using certain spaces around the building.

Method:

Design a modular model capable of simulating built form in one floor increments (4 m) and in horizontal increments (4m). The model should also use the following increments:

- Parking: 40m x 80m x 4m (h) = 120'x240'x12'
- Commercial: 40m x 80m x 4m (h) = 120'x240'x12'
- Office: 32m x 80m x 4m (h) = 96'x240'x12'
- Homes: 16m x 80m x 4m (h) = 48'x240'x12'

The model must be capable of withstanding 100 mph winds in the M.I.T. Wright Brothers' Wind Tunnel. It must be easily photographed while in the tunnel. It should fit into existing bases at the tunnel to save time and money. The model should simulate probable sizes and masses for the uses proposed (see chart above). The model must finally be capable of being changed and played with as required for the performance of the experiments.

2.6 WIND TUNNEL MODEL

DESIGN PROCESS

Sketch designs using slabs, towers, and blocks were explored. A sketch model of the tower and slab was made and accepted. Finnish plywood material was chosen for strength, durability, and beauty. Plywood was purchased, cut into basic pieces with a planer blade, and slots were cut with a sabre saw. All pieces were sanded, stained, and varnished with polyurethane varnish. The model was then assembled, tested, and adjusted as required.

Dimensions of the model were based on a 1 : 200 scale (1/200 actual size) because of the increased ease of use and construction of the model. The Finnish plywood pieces were 13 ply construction, 20.0 mm in thickness (0.75 inch). The plywood pieces represented floor levels 4 m in height; 20.0 mm represents 4 m in 1:200 scale. One unit = 4m or 12.5 ft. in 1 : 200 scale (1"=16')

Modular pieces simulate uses as follows:

- Parking: 40m x 80m x 4m (scale)
 2000 mm x 4000 mm x 200 mm (actual)
- Commercial: 40m x 80m x 4m (scale)
 2000 mm x 4000 mm x 200 mm (actual)
- Office: 32m x 80m x 4m (scale)
 1600 mm x 4000 mm x 200 mm (actual)
- Homes: 16 m x 80m x 4m (scale)
 800 mm x 4000 mm x 200 mm (actual)

Support pieces simulate vertically continuous elements (mechanical ducts, exit stairways, elevators, and support structure):

4m x 16m (scale)
200 mm x 800 mm (actual)

Pieces are suited to fit over supports stacking up to simulate a complete built form. Modular pieces are stained to differentiate uses:

- | | | |
|--------------|----------|--------|
| - Parking | birch | yellow |
| - Commercial | walnut | brown |
| - Office | mahogany | red |
| - Homes | pecan | orange |

(Consult Figures 10-13 pages 58-61.)

TESTING PROCEDURE

- Attach support base to tunnel base.
- Assemble model as desired.
- Check tunnel for loose stuff.
- Turn on tunnel flow gradually to protect people, the model, and the tunnel.
- Record velocities around model using manometers.
- Record flow around model using a smoke generator and by photographing the flow of smoke.
- Find configurations where wind velocities are the highest.
- Find configurations where wind velocities are highest in comparison to the ambient wind velocity (i.e., the most power being available where the velocity is highest).
- Place wind collector simulators in the places where high

- velocities occur to determine performance at that place.
- Find configurations where flows are troublesome and try to determine why.
 - Record results carefully and accurately, always.

2.7 WIND TUNNEL TESTS

The wind tunnel test model was designed for 100 mph wind velocities upon recommendation of Frank Durgin, wind tunnel director. The model was tested initially at 100 mph, 80 mph, 60 mph, 40 mph, and 20 mph for correlation between wind velocities around built form at these velocities. Wind tunnel time was limited to 6 days due to misconstruction of the model base. The model was first designed with a rectangular base. A circular base was found to be best for use in the wind tunnel. Thus, time was lost while rebuilding the model base. Use of the Wright Brothers' Wind Tunnel is provided for a charge of \$15/hour for unsponsored research. Outside groups must pay additional fees up to \$100/hour. Use of the tunnel at low velocities (40 mph = 59 fps) allowed work to proceed quickly as model changes and instrument changes could be made without shutting the tunnel down. Velocity tests were conducted at 40 mph wind velocity.

Boundary layer turbulence was simulated through the use of randomly shaped blocks and tall spires set into the tunnel at the beginning of the test section. The boundary layer

simulator set up may be seen in the model photographs. Different blocks and spires are used to simulate different boundary layers. Boston has a roughness factor of 0.25 ($\alpha = 0.25$) and was used for all of the tests. Flow tests, using a smoke generator, were conducted at 15 mph (approx. 22 fps) to allow people to be in the tunnel constantly to photograph, observe, and manipulate the model. The lower velocity allowed the smoke to be visible a bit longer before it was blown away down the tunnel. The Wright Brothers' Tunnel at M.I.T. is a closed loop tunnel, reusing the same air again and again. Re-using the same air alleviates problems caused by having to be careful of high pressure at the inlet and outlet of flow through tunnels. (Consult Figures 14-18 pages 62-66.)

2.8 WIND TUNNEL TEST RESULTS

GRAPHICAL REPORT OF TESTS

Exact scale section is given. Depth of model is projected from section and is foreshortened. Variables are indicated as follows:

V_{TC} = Wind velocity at top center

V_{TE} = Wind velocity at top edge

V_{SC} = Wind velocity at slot center

V_{SE} = Wind velocity at slot edge

V_{ME} = Wind velocity at middle edge

V_{BC} = Wind velocity at bottom center

V_{BE} = Wind velocity at bottom edge

φ = angle between wind direction and axis of openings
in built form

All velocities are measured around built form indicated
by drawings shown in this text.

Consult Figures 19 - 40 pages 67 - 88.

2.9 EVALUATION OF RESULTS

- Wind velocity increases with increased height above the ground.
- Wind direction and velocity are more consistent and predictable higher above the ground surface.

WIND TURBINE LOCATION IN BUILT FORM- Where to place wind turbines

- (1) Wind velocity is highest near the top of built form. Wind flow separates at edges and flows higher over the top of built form. Shelter effect occurs on top of built form.
- (2) Wind collectors could be located on top of built form. The advantages of such placement would be: high wind velocity, and ease of orientation. Disadvantages would include: added moment on the built form, no relief of wind pressure on the built form,

one point support for turbines, added support height required to reach above sheltered area, flow diverted over the top of the built form (resulting in loss of potential energy over the top), and velocity increase of twice the normal velocity is quite possible.

- (3) Wind collectors could be located in built form. The advantages of this would then be: low moment on built form, relief of wind pressure on built form, two point support for turbines, no added support required, flow diverted and increased through opening in built form, and velocity increased by 3 times (highly possible). Disadvantages would be: lower wind velocity closer to the ground, and built form's orientation would have to be set within certain limits (shape and orientation of built form are critical factors).

VELOCITY INCREASES RESULTING FROM BUILT FORM

Wind velocity may be increased by factors of 2.0-6.0 by using built form correctly. Wind velocity may be increased by careful placement of openings in the built form. Increase factors are lower as the opening is placed nearer to the top of the built form. The wind velocity increase at the top of the built form is 1.5 times the velocity normally experienced at the height above the ground. (This is 6.1 times the velocity at ground level.) Wind velocity increase around the sides of built form is 3.5 times the velocity normally experienced at that height above the

ground. Wind velocity around the sides of the built form is 0.6 times the velocity at the top of the built form.

OPENINGS IN BUILT FORM

Opening shape is a critical factor for increasing wind velocity with built form. Opening size is a critical factor for increasing wind velocity with built form. Ratio of opening depth to opening height is a critical factor for increasing velocity of the wind. Opening position is a less critical factor for increasing wind velocity with built form.

Opening Shape:

The maximum velocity shape seems to be a half taper opening toward the top of the built form. (Consult Figures 18 & 39.) The maximum velocity height (size) seems to be three units. The maximum velocity depth seems to be equal to or a bit less than the maximum velocity height. The width of the opening seems to be a non-critical factor when width is equal to or greater than the height of the opening. Openings at the building edge provide less velocity increase than openings at the center of the building.

WIND FLOW

Wind flow at the base of the built form decreases when openings are added above it. Wind flow out of the taper opening seems equivalent to the ambient wind flow, re-

sulting in no added flow velocity on the leeward side of the opening.

FURTHER EXPERIMENTS TO MAKE

- Test higher openings to compare with 3 unit maximum used for preliminary tests.
- Test wind collectors in openings to check for choking, disturbance of flow, and slowing down of wind.
- Test lower built forms for wind flow and velocity characteristics.
- Test clusters (groupings) of built forms for wind flow and velocity characteristics. Vary height, width, position of form.
- Test non-symmetrical configurations of built form to check wind flow and velocity characteristics.

Consult Figures 41-44 pages 89-92.

SUPPORT DESIGN

Wind collectors require open spaces relatively free from obstructions. Wind collectors incorporated into built form pose an interesting problem concerning continuity of structure and vertical systems: structure and vertical systems (mechanical shafts, lifts and exit stairways) carried through a space occupied by wind collectors could seriously obstruct the open space required for the wind collectors to function properly. Careful placement and shaping of structure and vertical systems could enhance the

function of the wind collectors.

Many techniques are available to help keep the wind collector space free of obstructions. Let us explore some of the possibilities. Vertical support and systems will be required somewhere through the wind collector space (we cannot hold up much mass with hot air balloons alone!). Vertical supports passing through the wind collector space should be carefully placed and designed to reduce productivity of collectors as little as possible; and perhaps enhance productivity. Continuous vertical systems (including structure) might become wind deflector to help guide wind through collectors when approaching from an undesirable direction. Vertical systems could help smooth out flow through wind collectors. The productivity of the collectors would be enhanced in both cases.

We now have some ideas for utilizing continuous vertical systems to enhance the output of wind collectors. The wind collectors require a space as unobstructed as possible. Penetration of wind collector space by vertical systems should be kept to the minimum required to support the built form above. Let us assume that one support minimum and six supports maximum are necessary. Now we have our design parameters (1-6 supports and free collector space) and can explore the possibilities for support. Possibilities for supporting free space above wind collectors can be classified into three major areas. Support systems, suspension systems, and a combination sup-

port-suspension system are the three major areas.

FREE SPACE STRUCTURE ALTERNATIVES

MATERIALS	DENSITY	SUPPORT	SUSPENSION	SUPPORT SUSPENSION
Steel	L-M-H	steel section truss funicular	cable post stress	cable/ section
Wood	L-M	solid truss funicular		steel/wood
Plastic	L-M	inflatable air sup- ported		steel/ plastic
Concrete	L-M-H	solid truss funicular		steel/ concrete

Your choice of structural system should depend upon materials available, labor available, construction techniques, size of building, major support system, fire codes, and building codes.

SUMMARY OF RESULTS

Consult Figures at the back of this section.

- (1) Wind velocity through openings in buildings can be increased 2 to 4 times above the ambient wind velocity normally occurring at the level of the opening with careful design of the opening.
- (2) Energy can be produced in substantial quantities with the increased wind velocity and the use of wind collectors. Enough energy can be provided to supply the entire requirements of a building in many cases.
- (3) Wind problems at pedestrian levels are decreased when openings are created to utilize wind energy.
- (4) Wind flow problems associated with high buildings can be controlled, predicted, and reduced with careful design.
- (5) Wind velocity increases can be achieved for high, medium, and low density situations.
- (6) Wind collectors can be successfully integrated into the design of buildings.
- (7) Wind flows around obstructions in a predictable manner.
- (8) A fixed position wind collector has a useful collection angle of 70° on each side of the collector axis.
- (9) Structural wind loads are greatly reduced when openings are introduced into buildings. The building acts as a permeable obstruction to the wind flow instead of a solid obstacle.

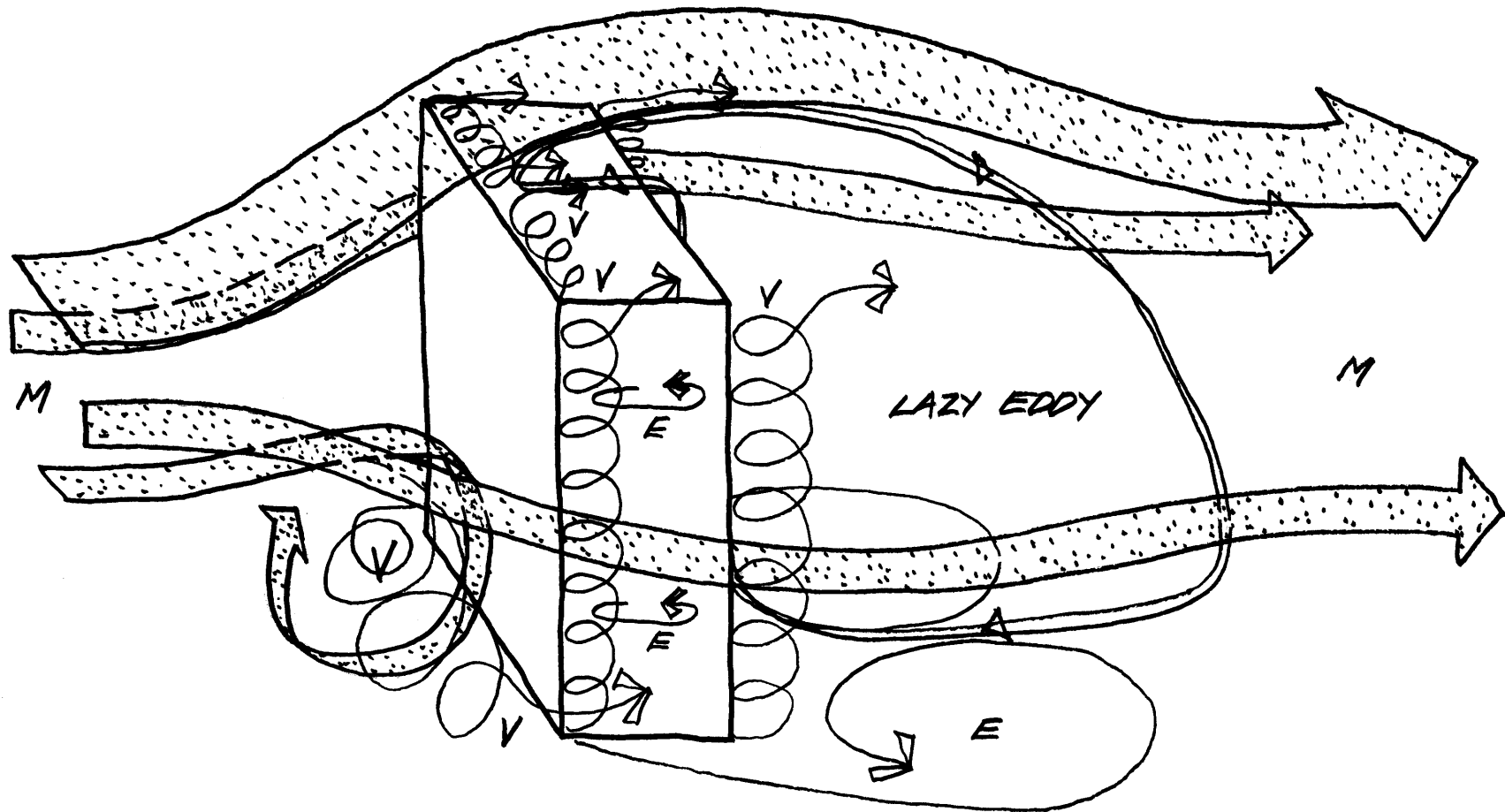

WIND 90° TO FACE OF BUILT FORM
 KEY: M = MAINSTREAM FLOW, V = VORTEX FLOW, E = EDDY FLOW
 (FROM AYSLEY.)
 WIND FLOW AROUND BUILT FORM

FIGURE 1

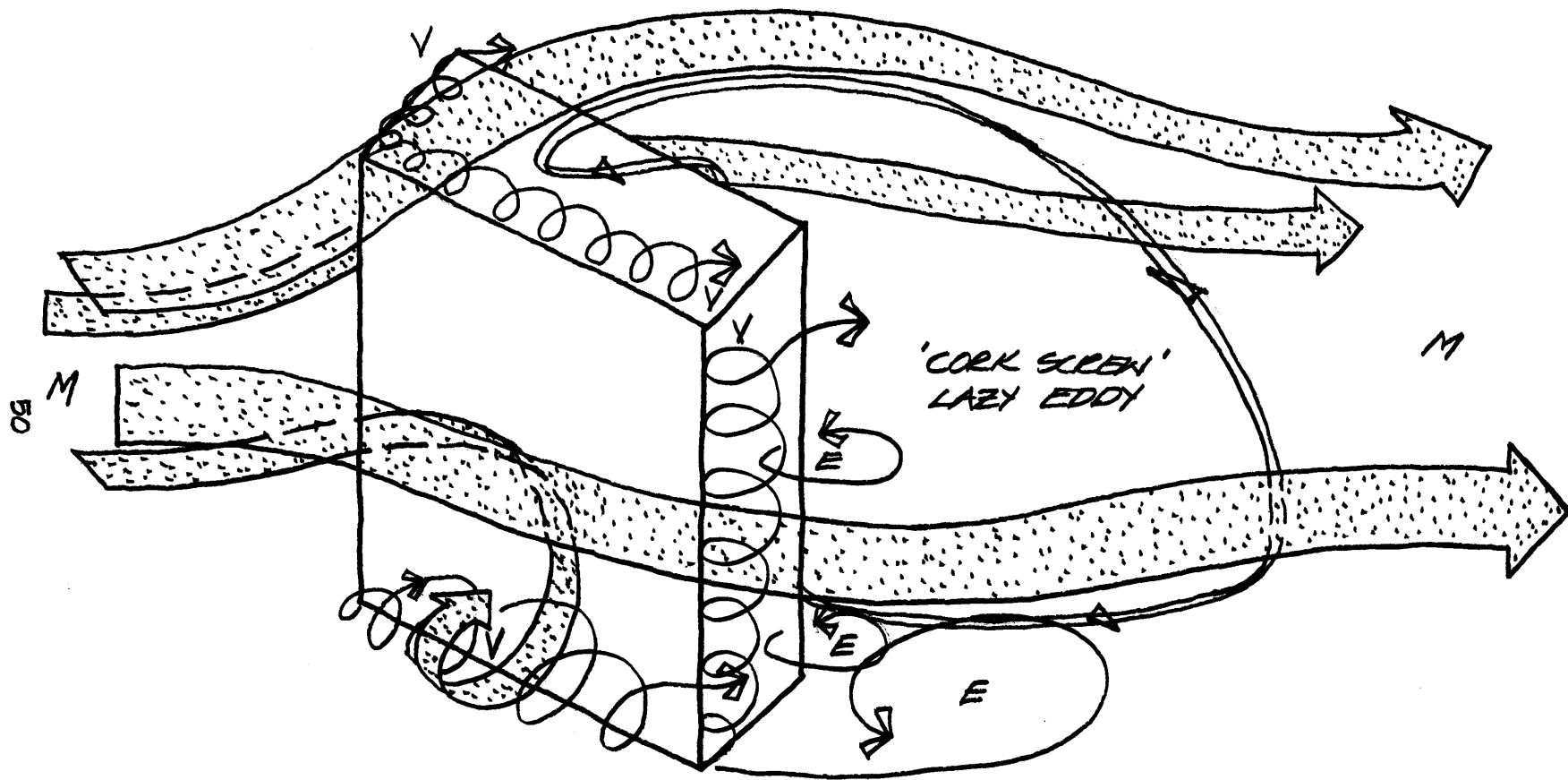

WIND 45° TO FACE OF BUILT FORM

KEY: M = MAINSTREAM FLOW, V = VORTEX FLOW, E = EDDY FLOW

WIND FLOW AROUND BUILT FORM

FIGURE 2

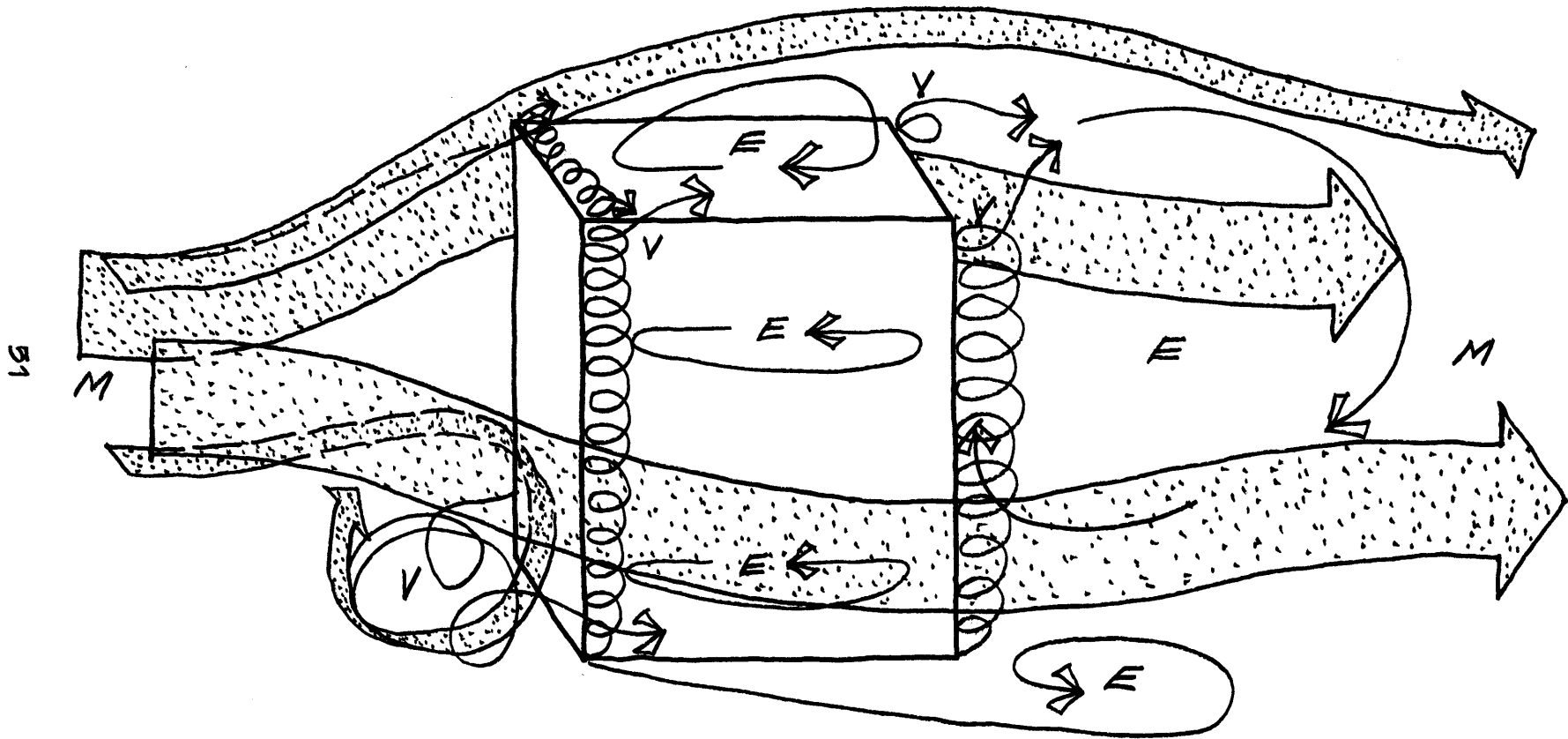

WIND PARALLEL TO FACE OF BUILT FORM
 KEY: M = MAINSTREAM FLOW, V = VORTEX FLOW, E = EDDY FLOW
 (FROM AYNLEY.)
 WIND FLOW AROUND BUILT FORM

FIGURE 3

B2

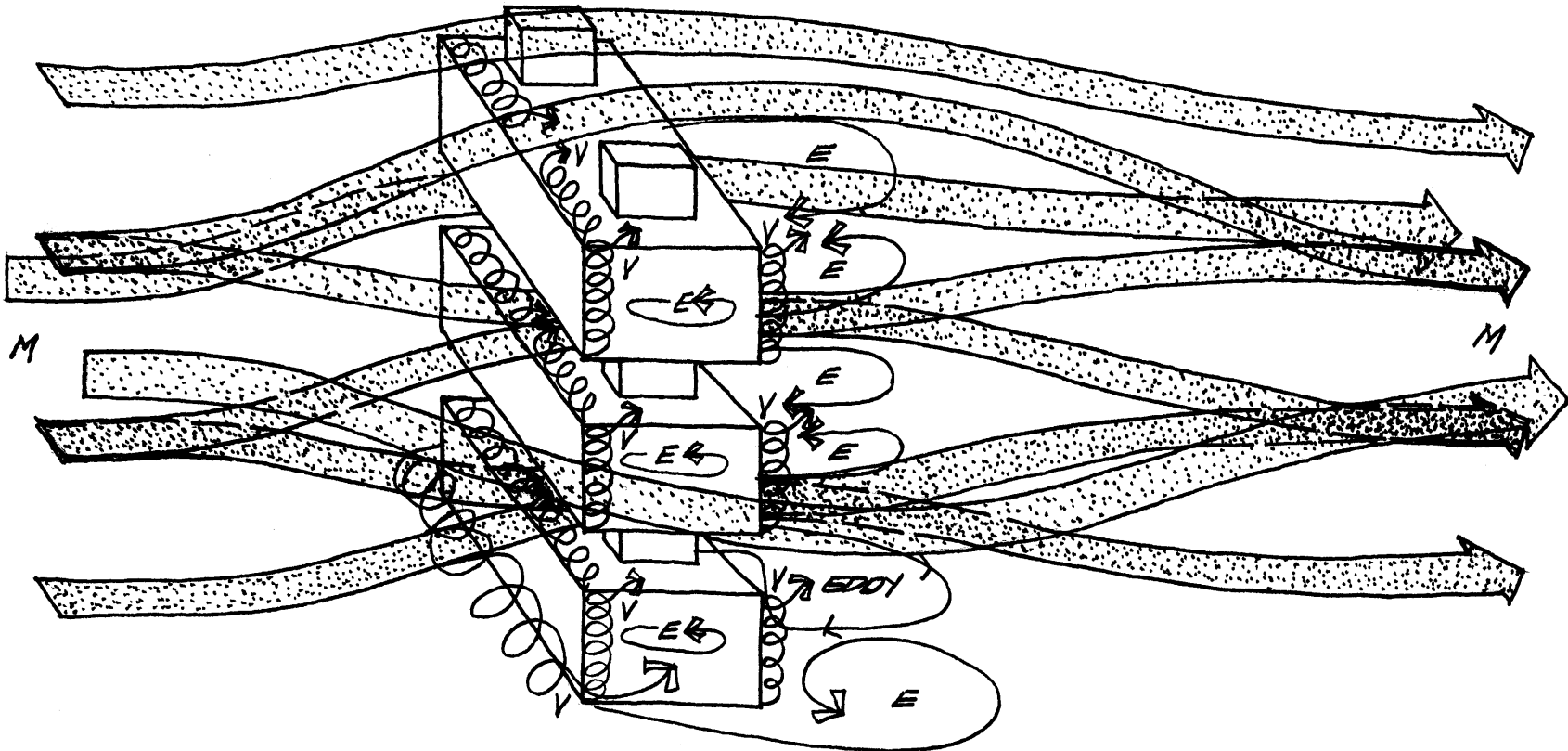

WIND 90° TO FACES OF BUILT FORM
KEY: M = MAINSTREAM FLOW, V = VORTEX FLOW, E = EDDY FLOW

WIND FLOW AROUND BUILT FORM

FIGURE 4

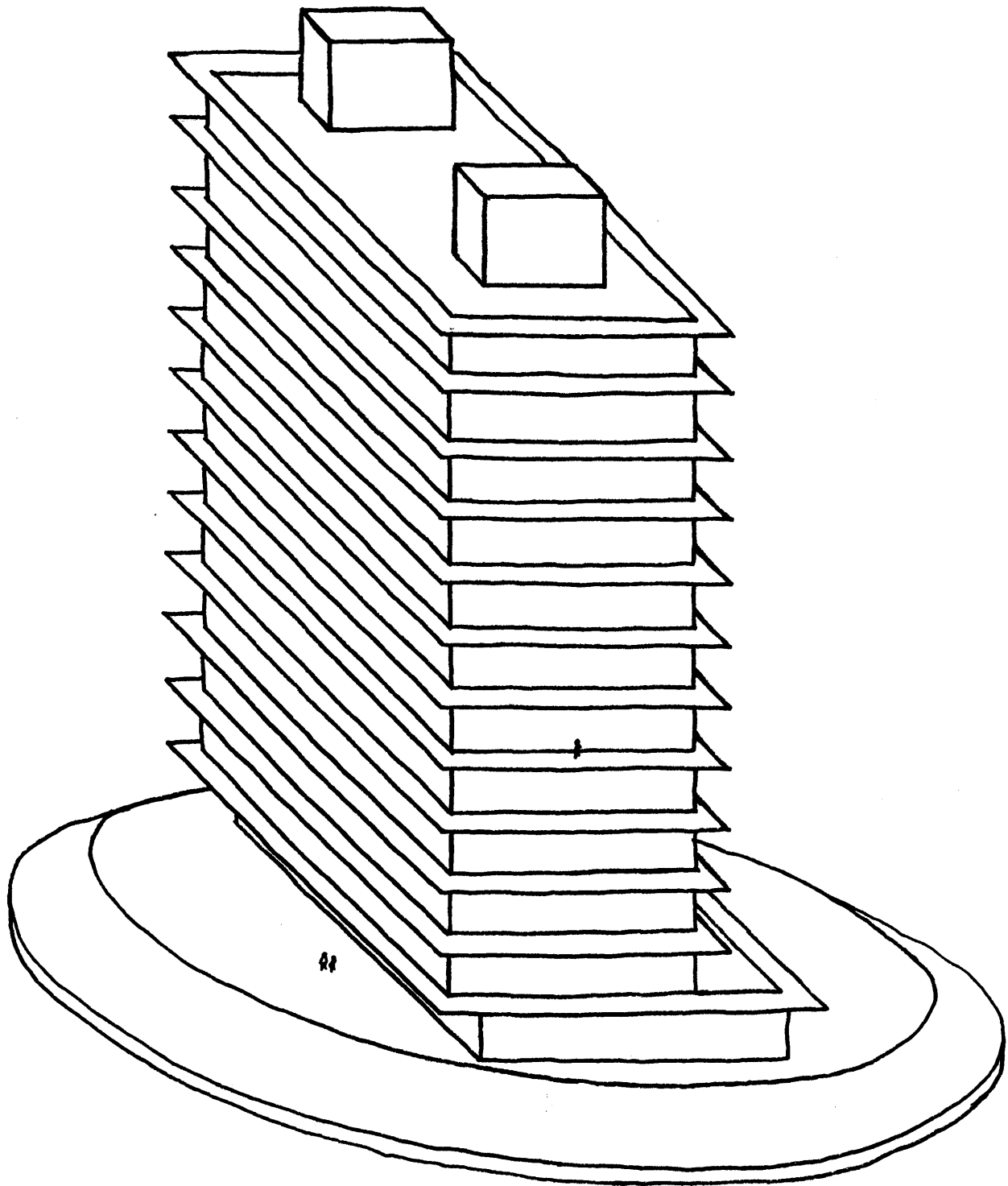

DESIGN RECOMMENDATIONS
HORIZONTAL PROJECTIONS

FIGURE 5

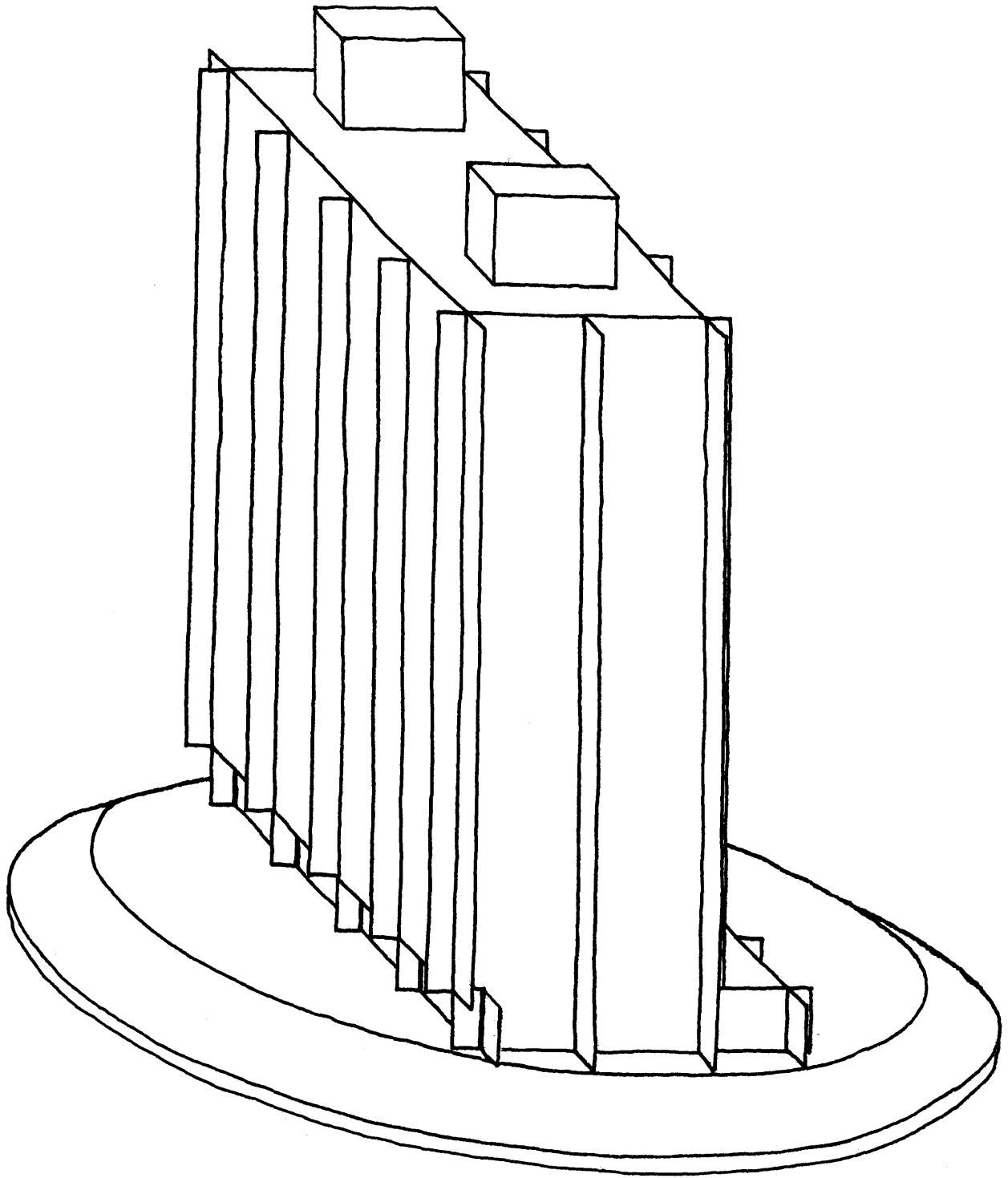

DESIGN RECOMMENDATIONS
VERTICAL PROJECTIONS

FIGURE 6

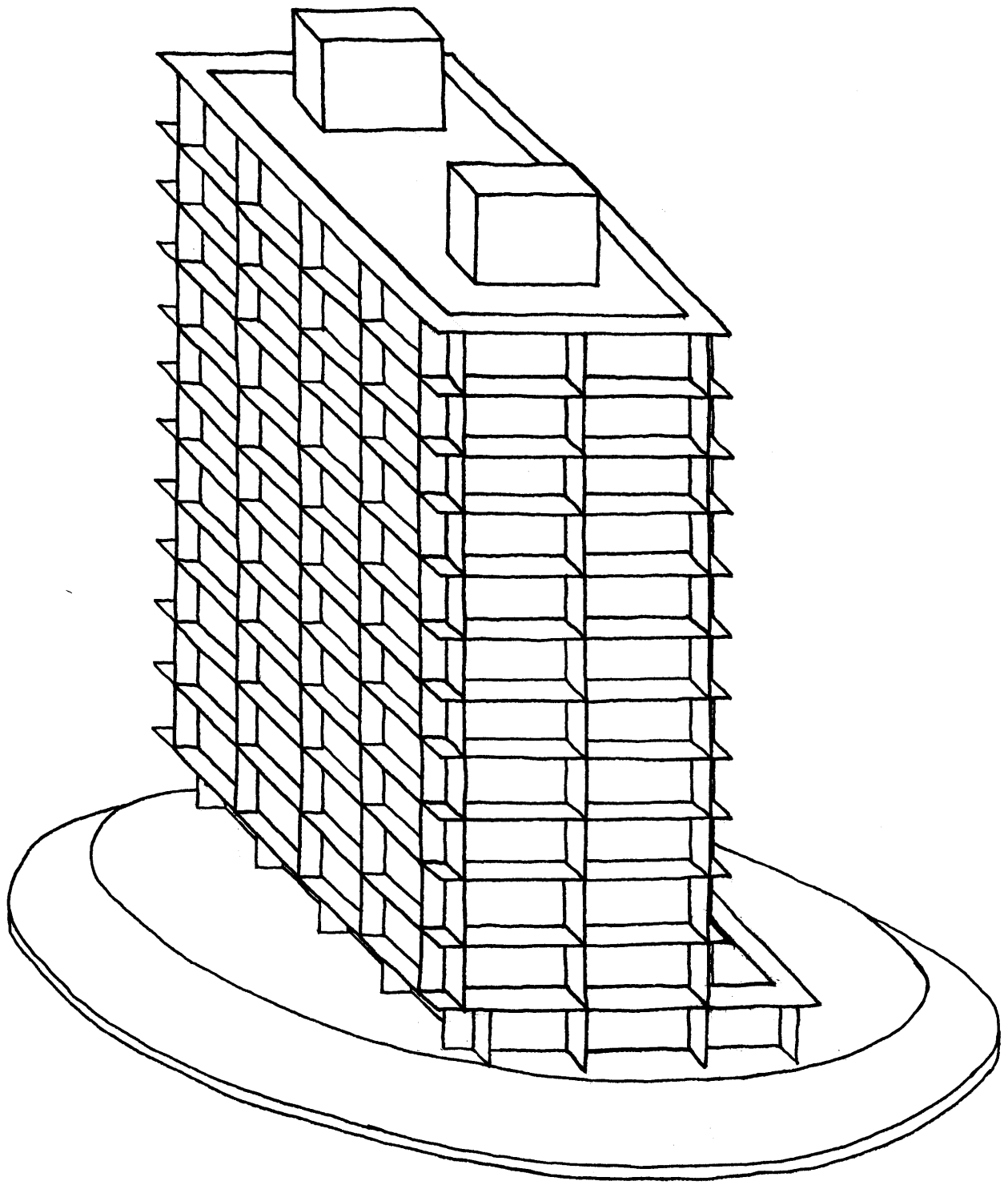

DESIGN RECOMMENDATIONS
EGG-CRATE PROJECTIONS

FIGURE 7

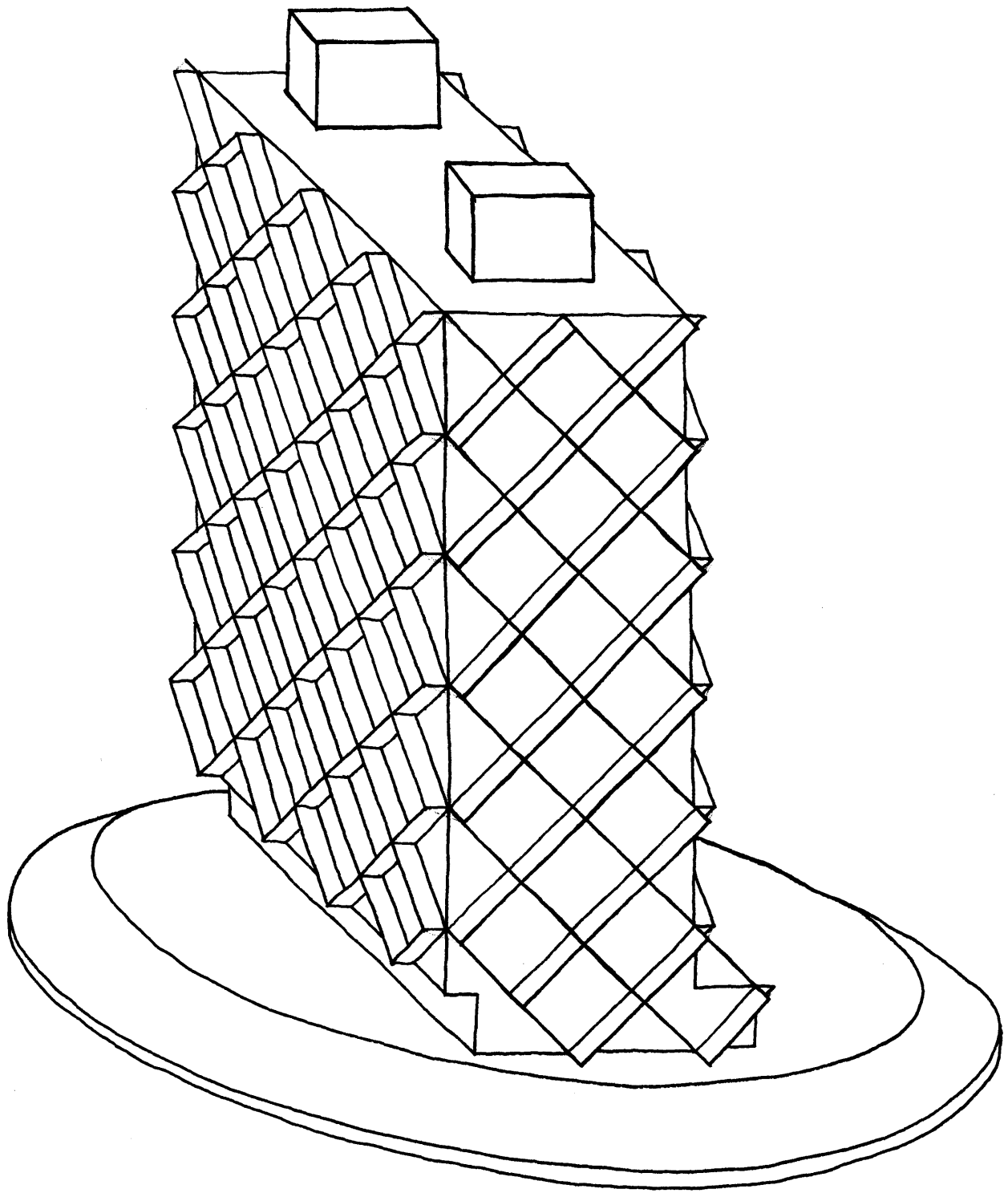

DESIGN RECOMMENDATIONS
DIAGONAL EGG-CRATE PROJECTIONS

FIGURE 8

MICROCLIMATE AROUND
BUILT FORM

FIGURE 9

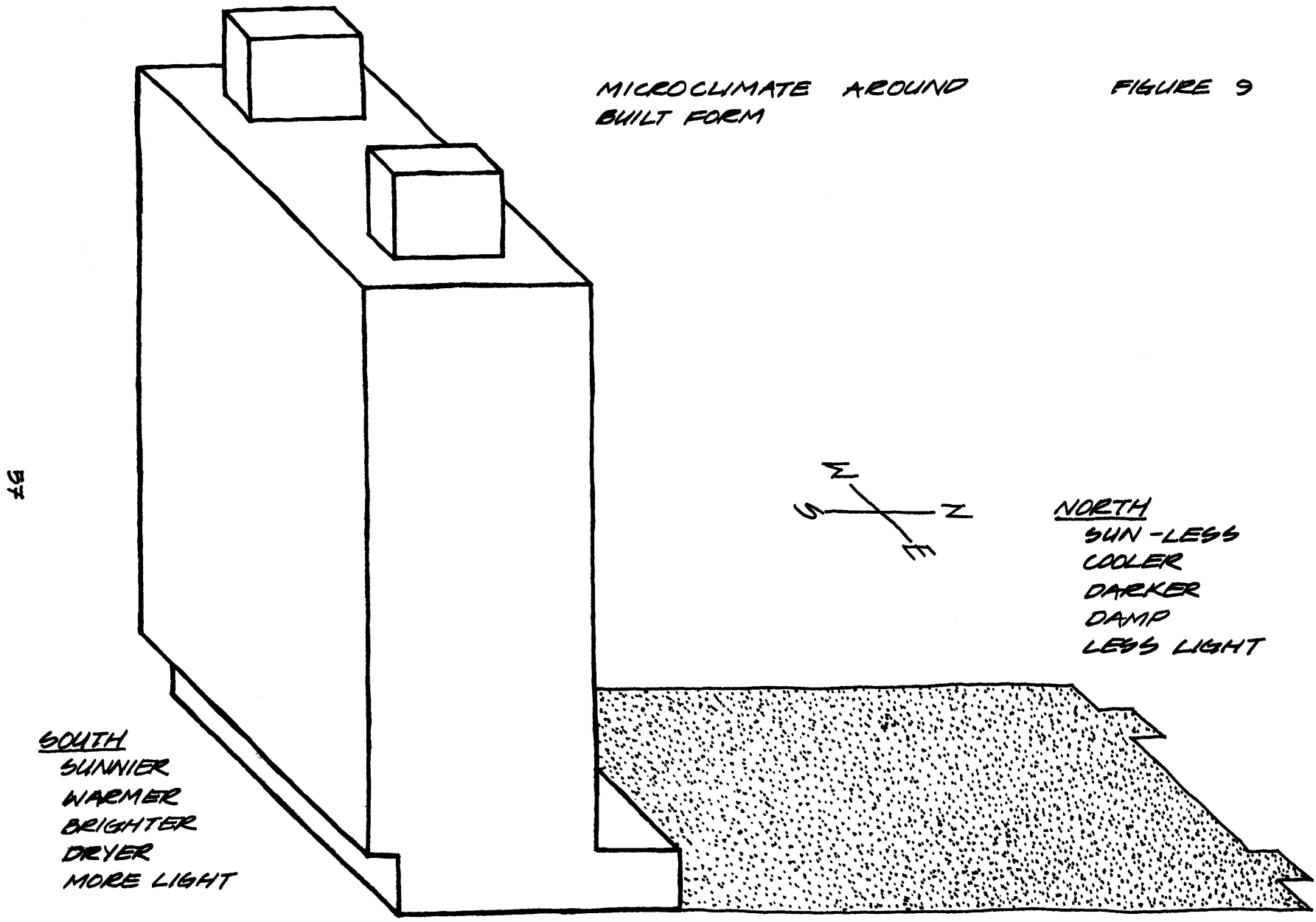

BF

SOUTH
SUNNIER
WARMER
BRIGHTER
DRYER
MORE LIGHT

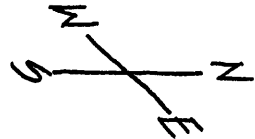

NORTH
SUN-LESS
COOLER
DARKER
DAMP
LESS LIGHT

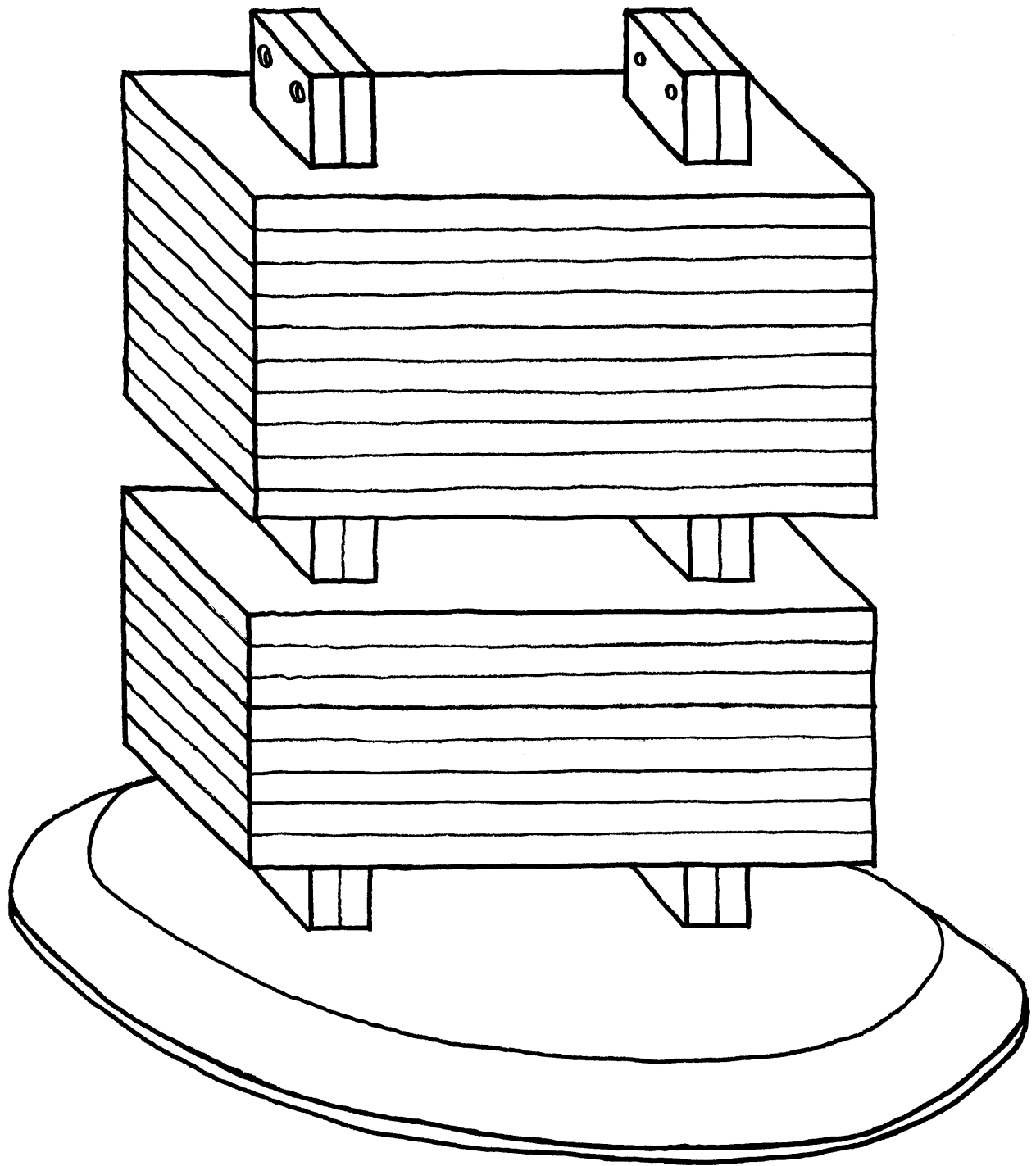

ASSEMBLED VIEW OF THE
WIND TUNNEL MODEL

FIGURE 10

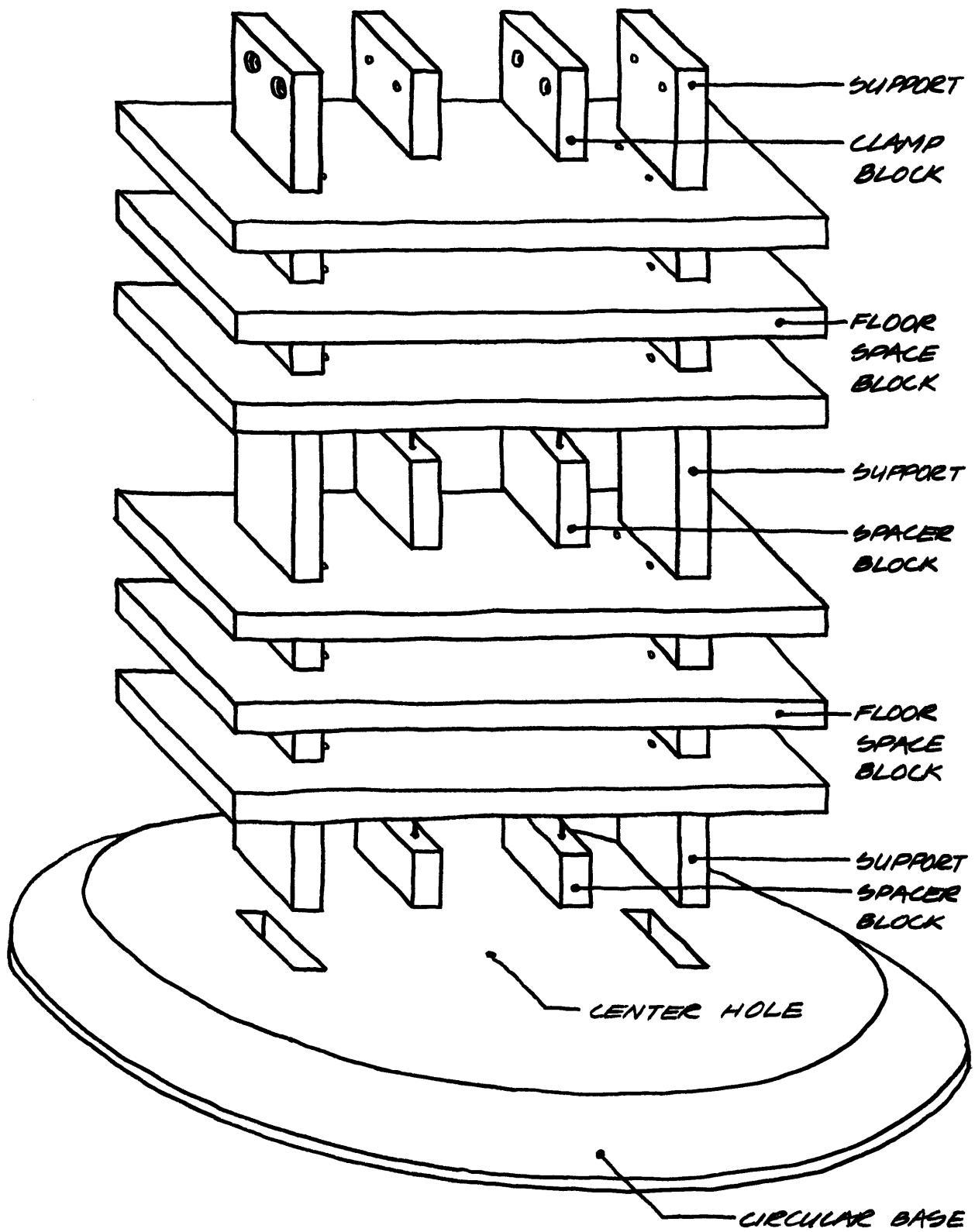

WIND TUNNEL MODEL
EXPLODED VIEW

FIGURE 11

09

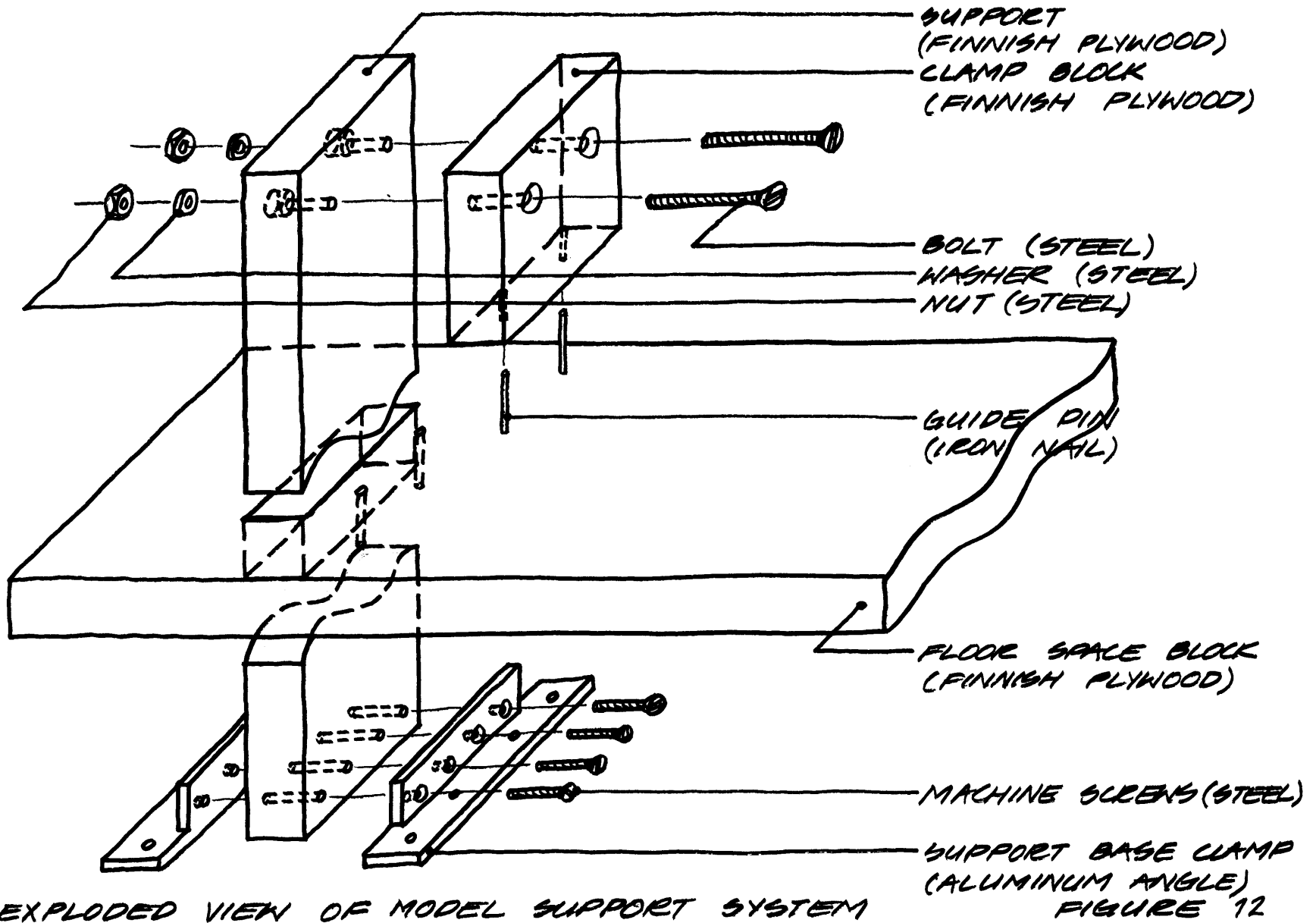

EXPLODED VIEW OF MODEL SUPPORT SYSTEM

FIGURE 12

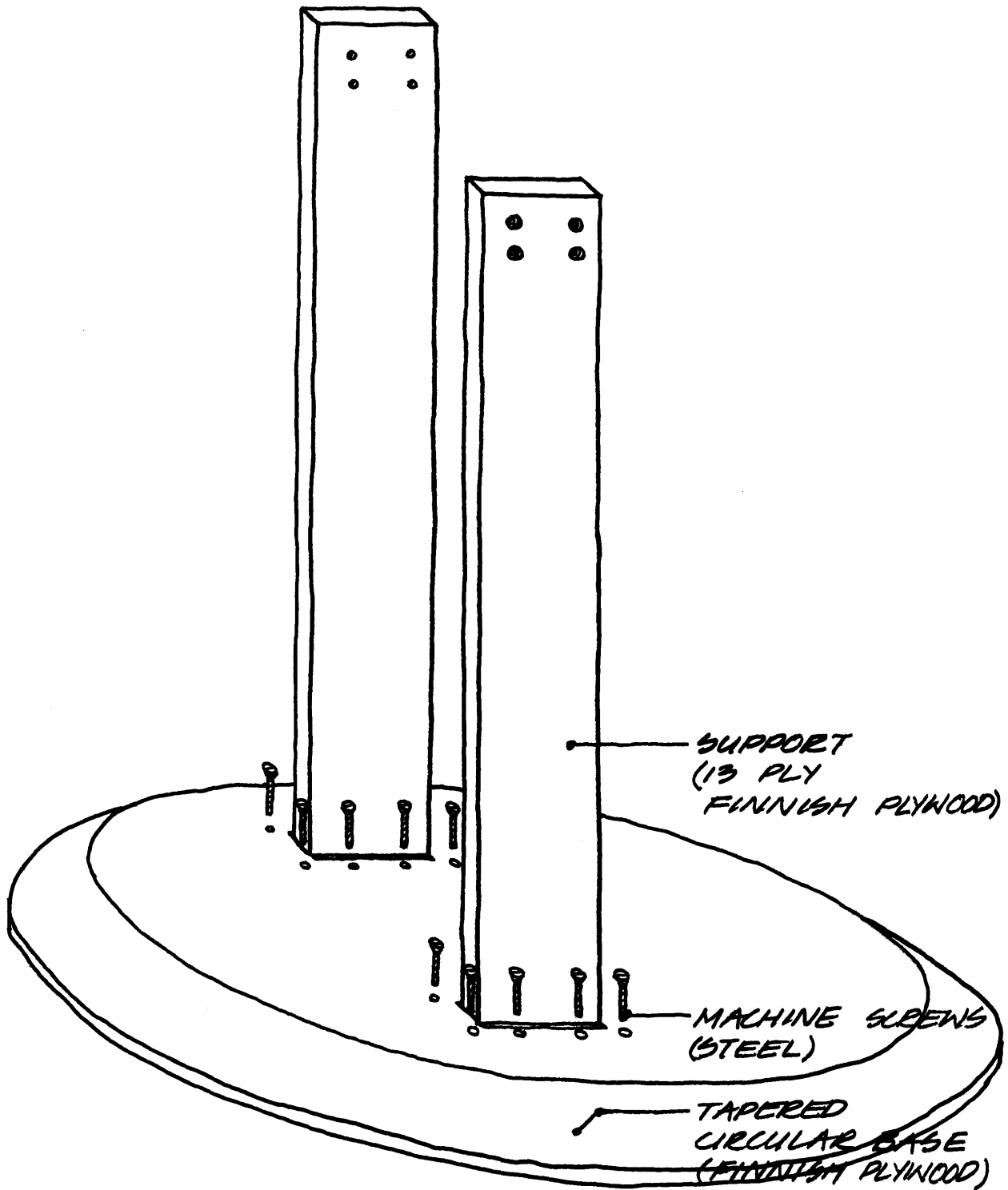

WIND TUNNEL MODEL
BASE AND SUPPORT ASSEMBLY

FIGURE 13

CLOSED LOOP TUNNEL
(DOUGHNUT)

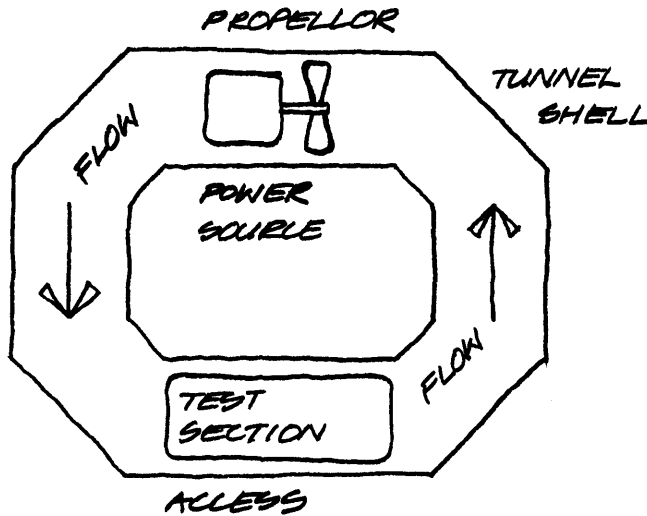

ADVANTAGES

- CONTROLLED FLOW
- NO INLET SUCTION
- NO OUTLET PRESSURE
- RECYCLES AIR
- USES LESS ENERGY TO RUN
- CONTROLLED NOISE

DISADVANTAGES

- EXTRA COSTS
- LARGE AREA OCCUPIED

OPEN LOOP TUNNEL
(FLOW - THROUGH)

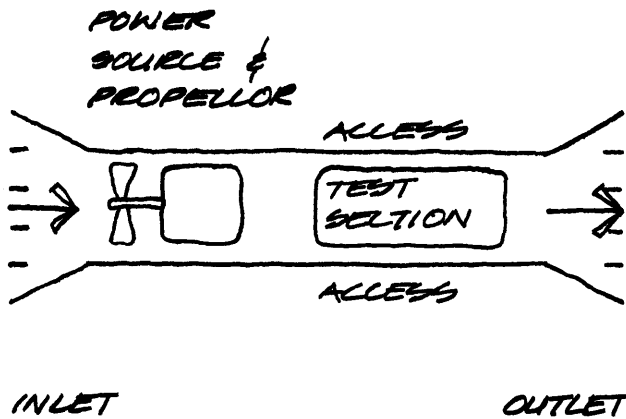

ADVANTAGES

- LOW COST
- SMALL AREA OCCUPIED

DISADVANTAGES

- LESS CONTROLLED FLOW
- INLET SUCTION
- OUTLET PRESSURE
- NEW AIR REQUIRED
- USES MORE ENERGY TO RUN
- NOISE

FIGURE 15

MOTOR
2000 HP
SQUEEZED CAGE
INDUCTION MOTOR

FOUR
SYNCHRONOUS
SPEEDS
1200, 900, 650,
450 RPM

PROPELLOR
13' DIAMETER
6 BLADES WOOD
CONTROLLABLE
PITCH

BLADE WIDTH
= 1.08'
WIDTH RATIO
= 0.50

VOLUME
170 D³

OCTOBER 1938
1/192 SCALE

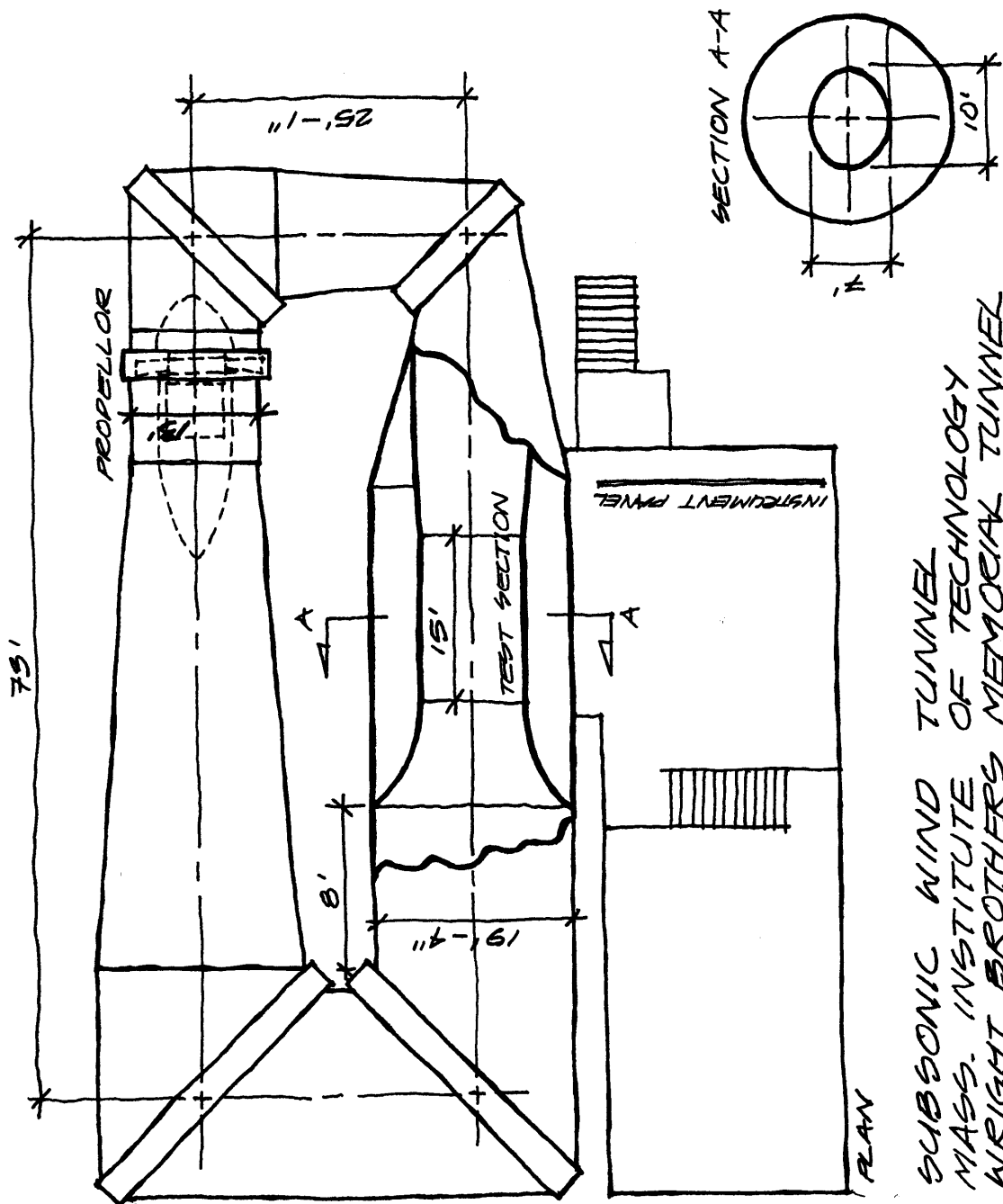

SUBSONIC WIND TUNNEL
MASS. INSTITUTE OF TECHNOLOGY
WRIGHT BROTHERS MEMORIAL TUNNEL

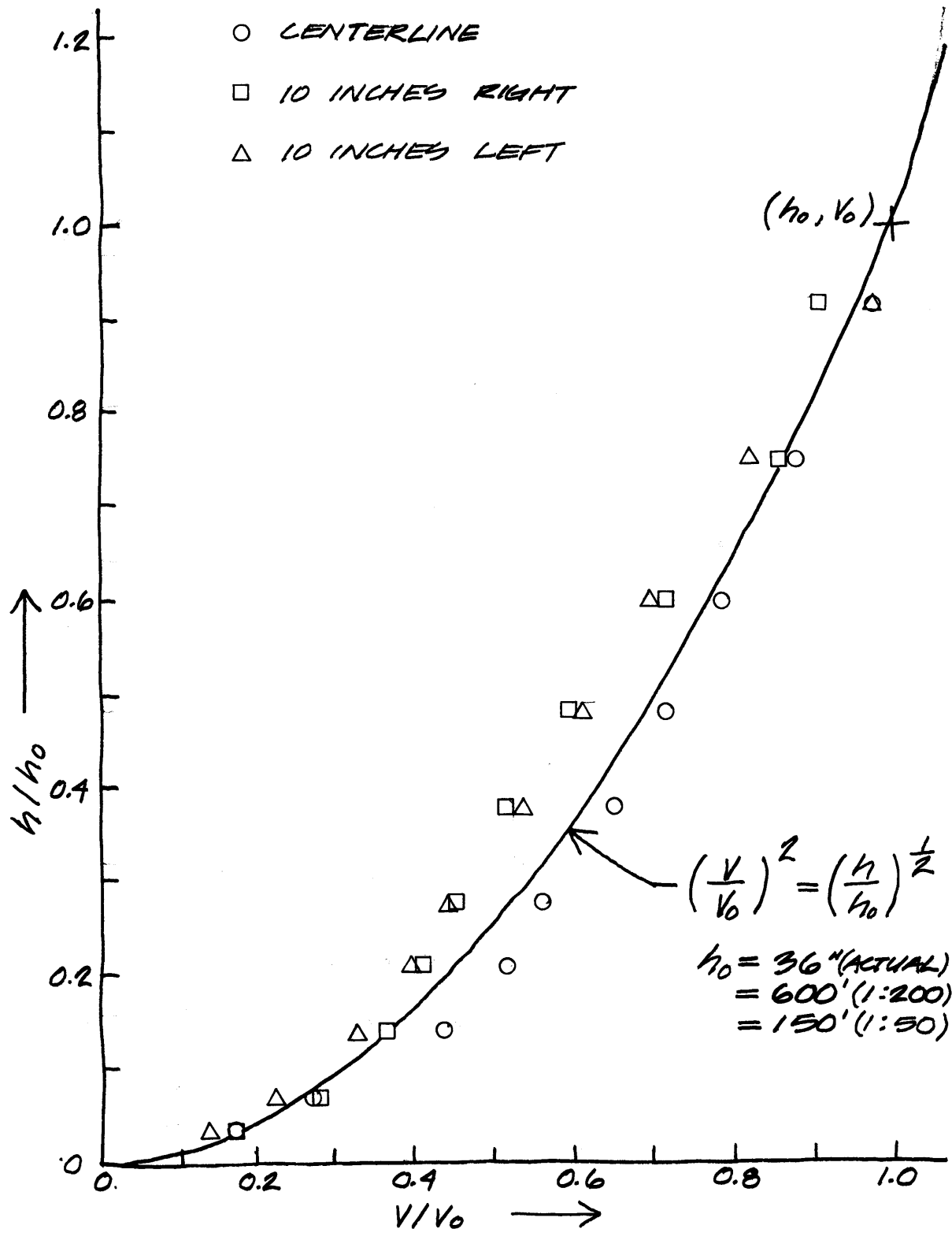

BOUNDARY LAYER - ROUGHNESS $\alpha = 0.25$
 VELOCITY GRADIENT DATA FIGURE 16

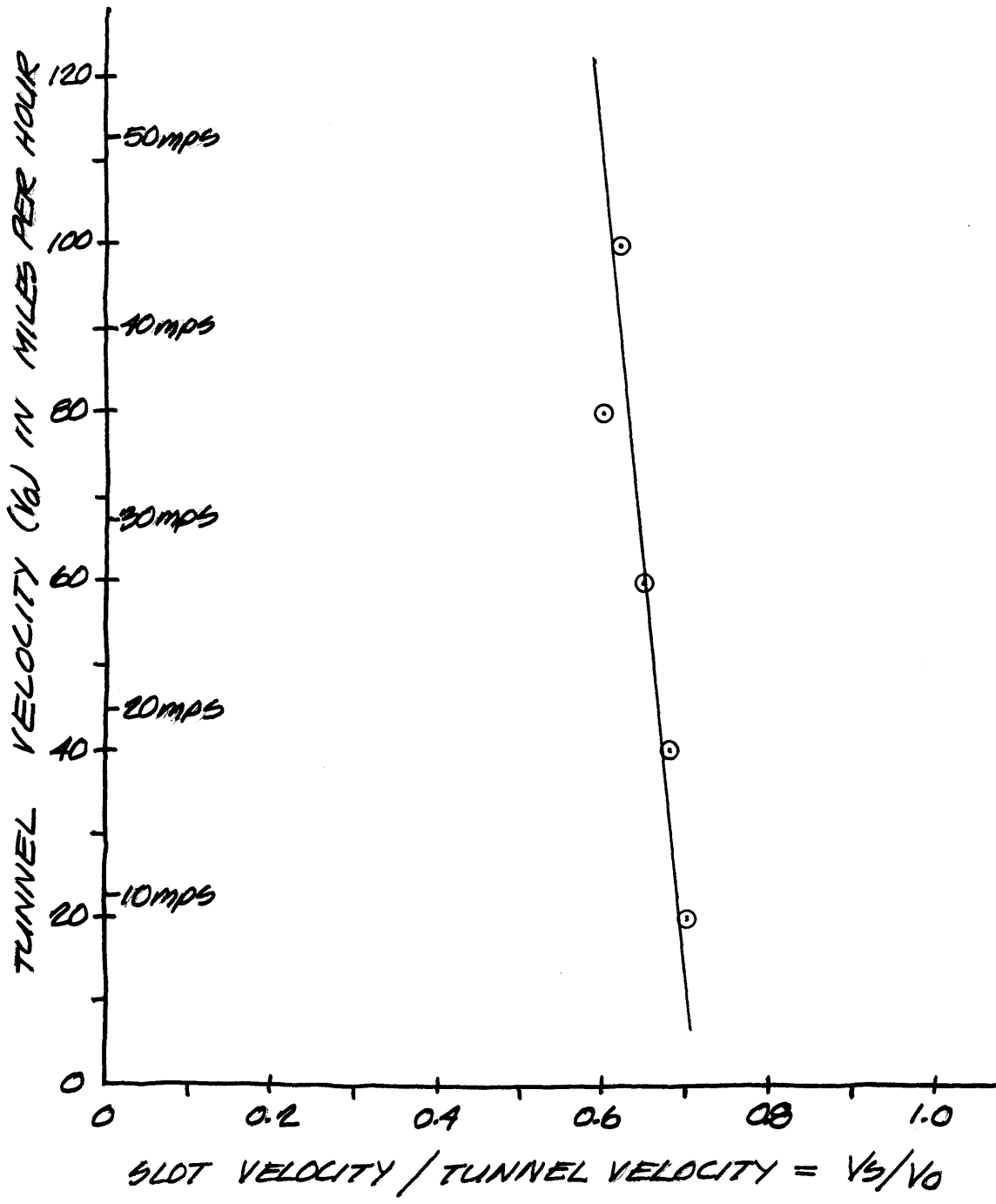

SLOT SHAPE : 1U-R , 7 UNITS ABOVE GROUND

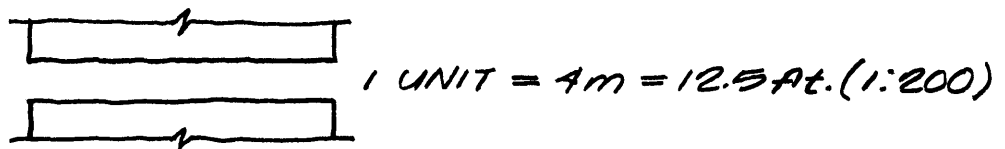

VELOCITY CORRELATION TEST

FIGURE 17

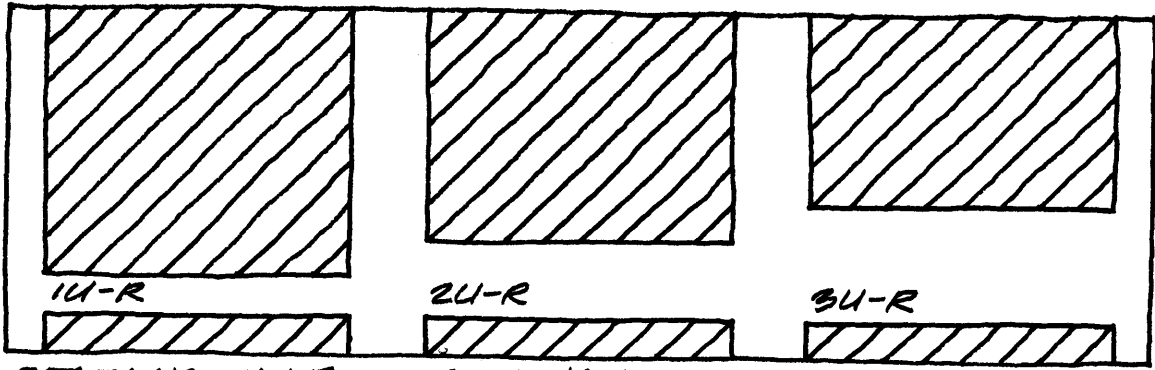

RECTANGULAR OPENINGS

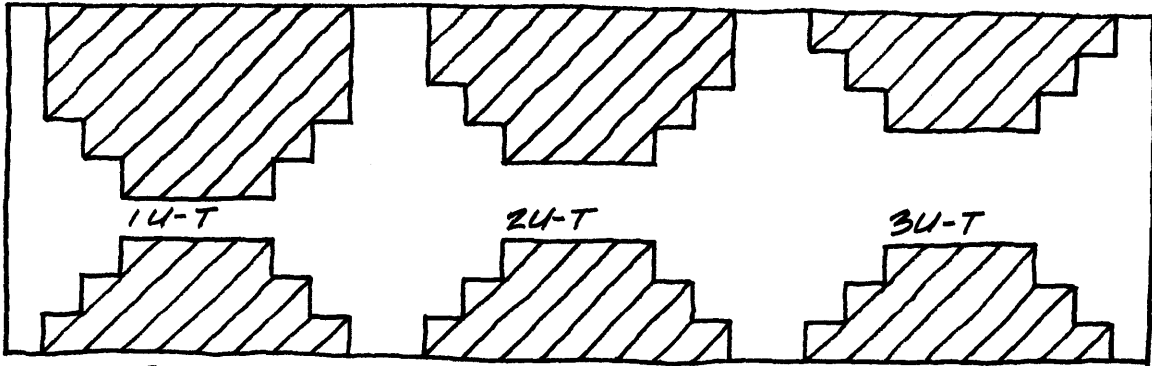

TAPERED OPENINGS

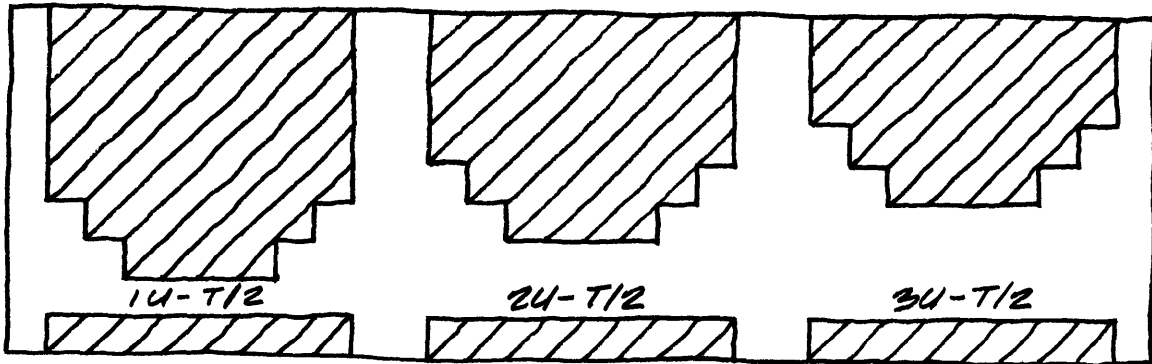

HALF-TAPERED OPENINGS

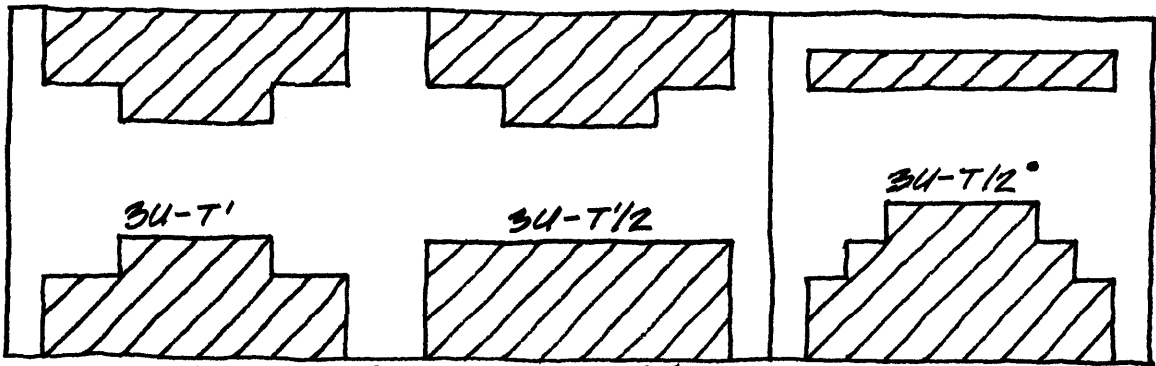

NARROW TAPERED OPENINGS

REVERSE TAPER

OPENING SHAPES TESTED

FIGURE 18

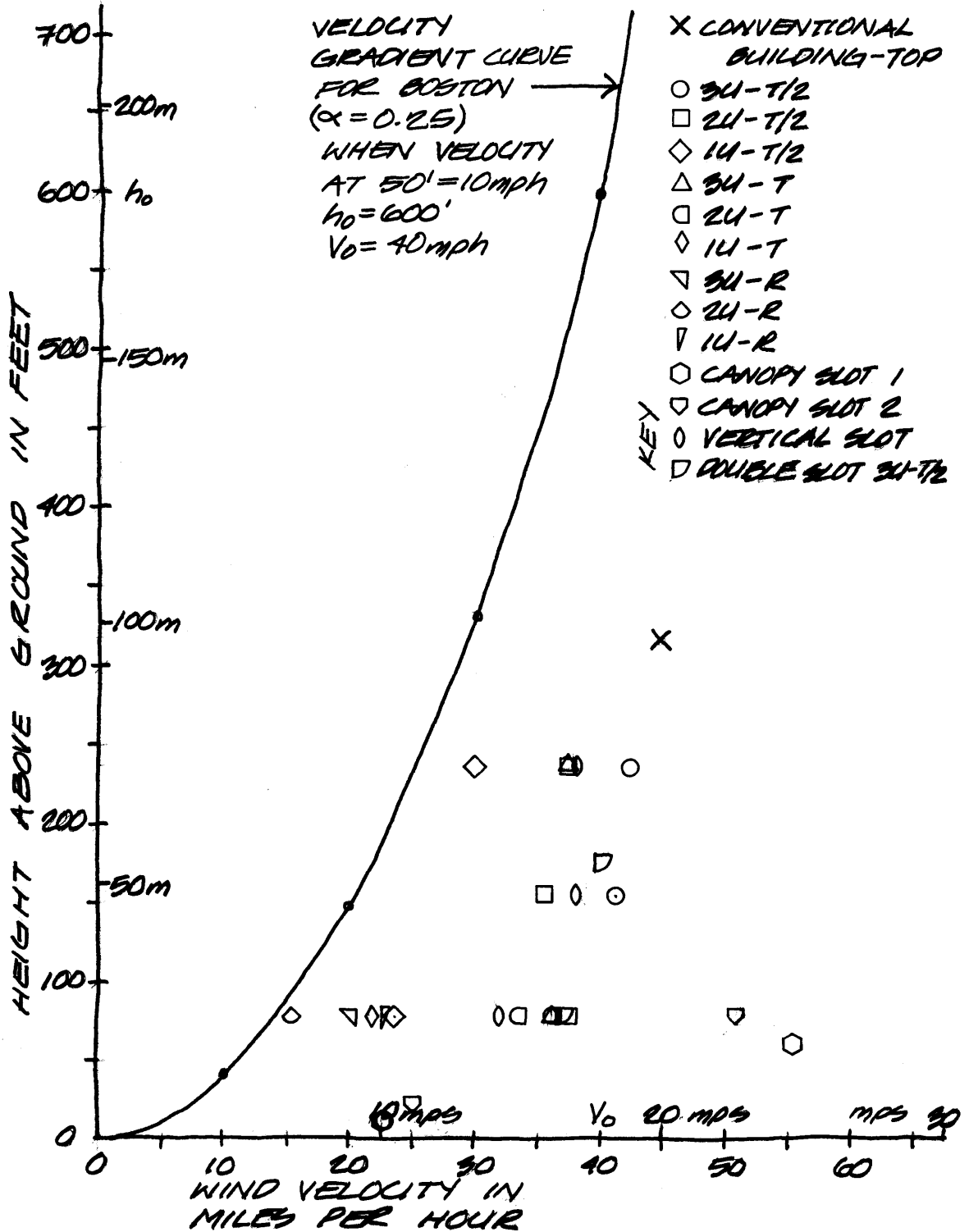

φ = ANGLE BETWEEN WIND DIRECTION AND AXIS OF OPENING IN BUILT FORM

WIND TUNNEL $\varphi = 0^\circ$
 TEST RESULTS FOR BUILDING SHAPES FIGURE 19

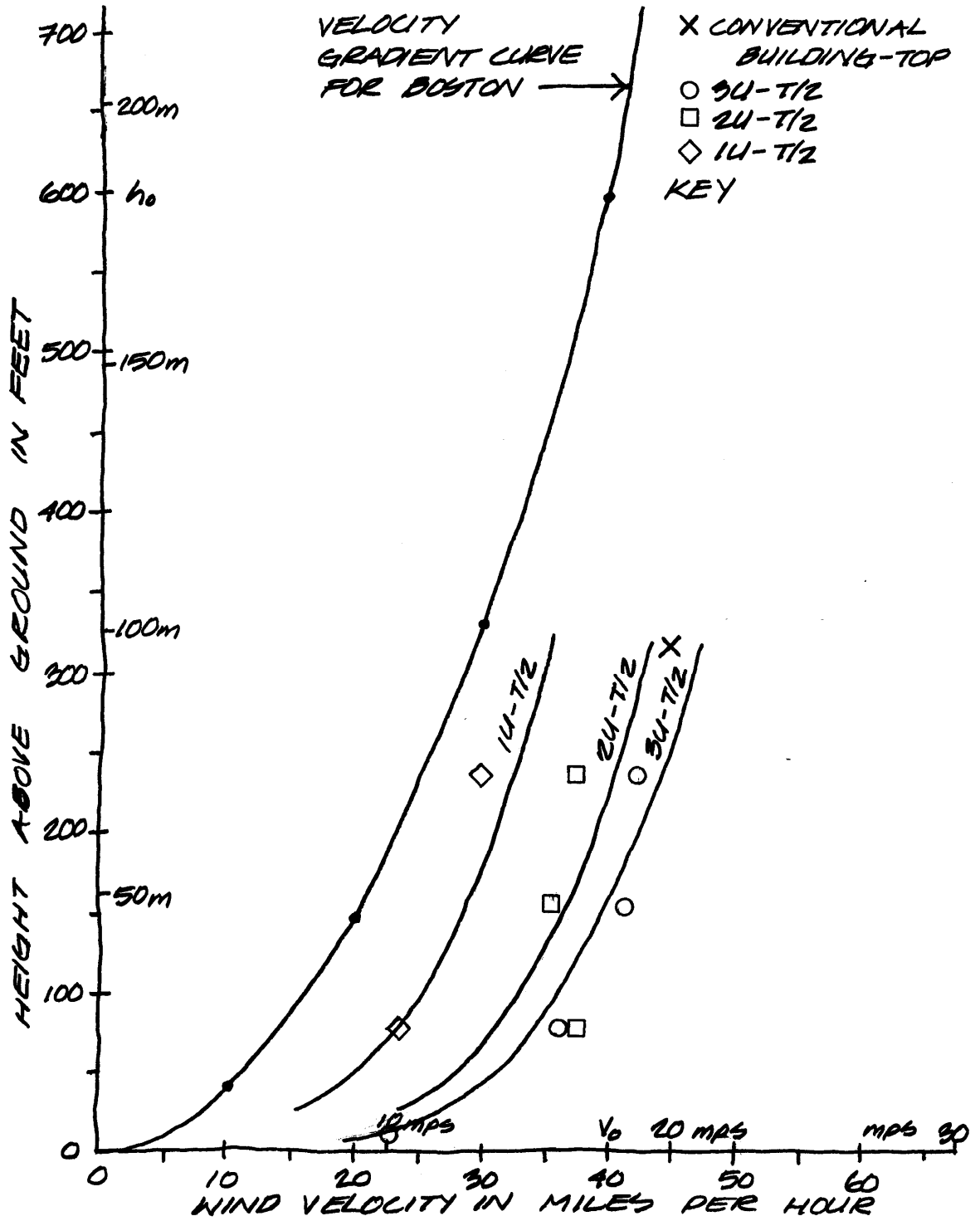

HALF TAPER SLOTS - $\phi = 0^\circ$
VELOCITY INCREASE CURVES

FIGURE 20

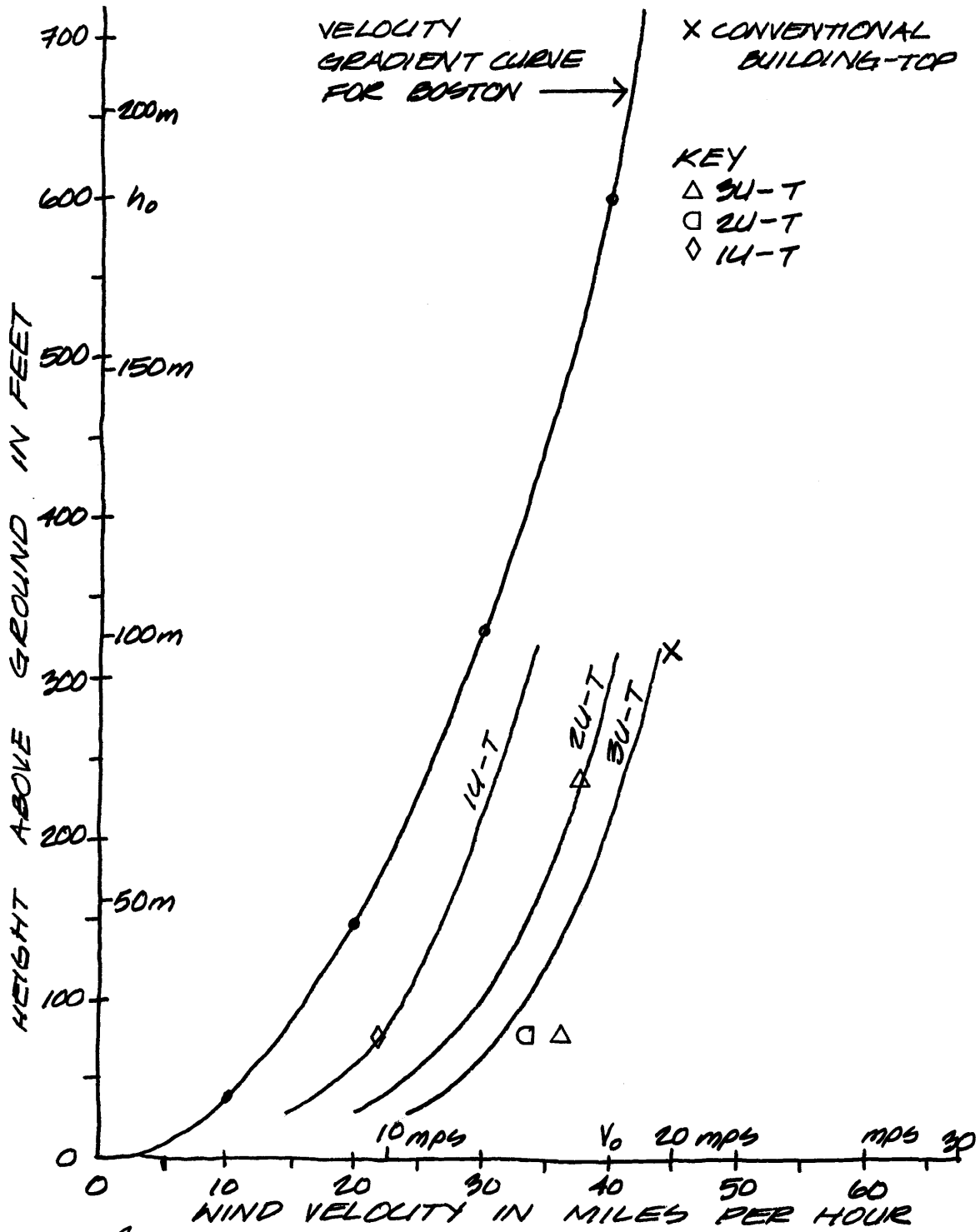

TAPER SLOTS - $\phi = 0^\circ$
VELOCITY INCREASE CURVES

FIGURE 21

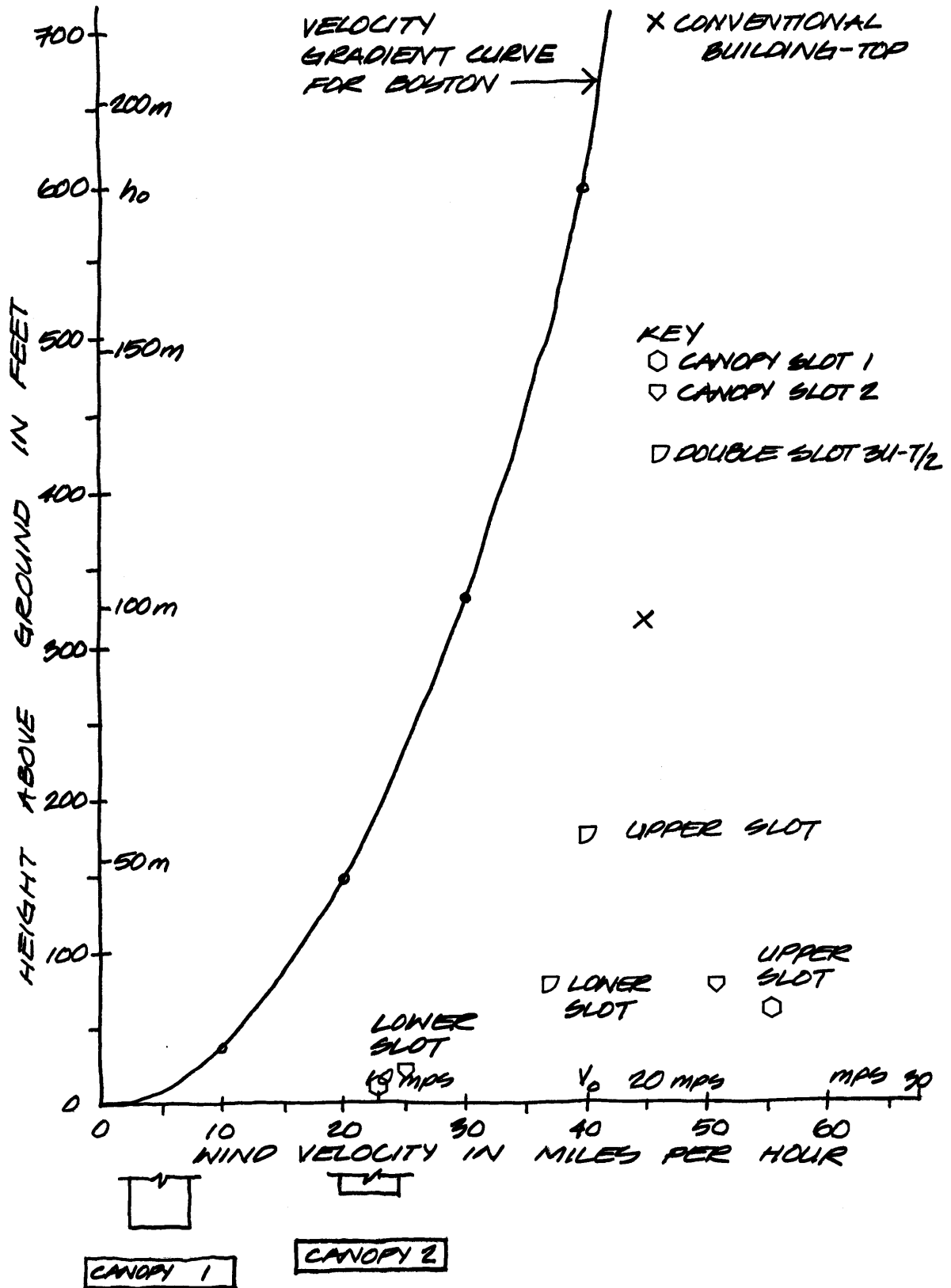

DOUBLE SLOTS $\varphi = 0^\circ$
VELOCITY INCREASE RESULTS

FIGURE 22

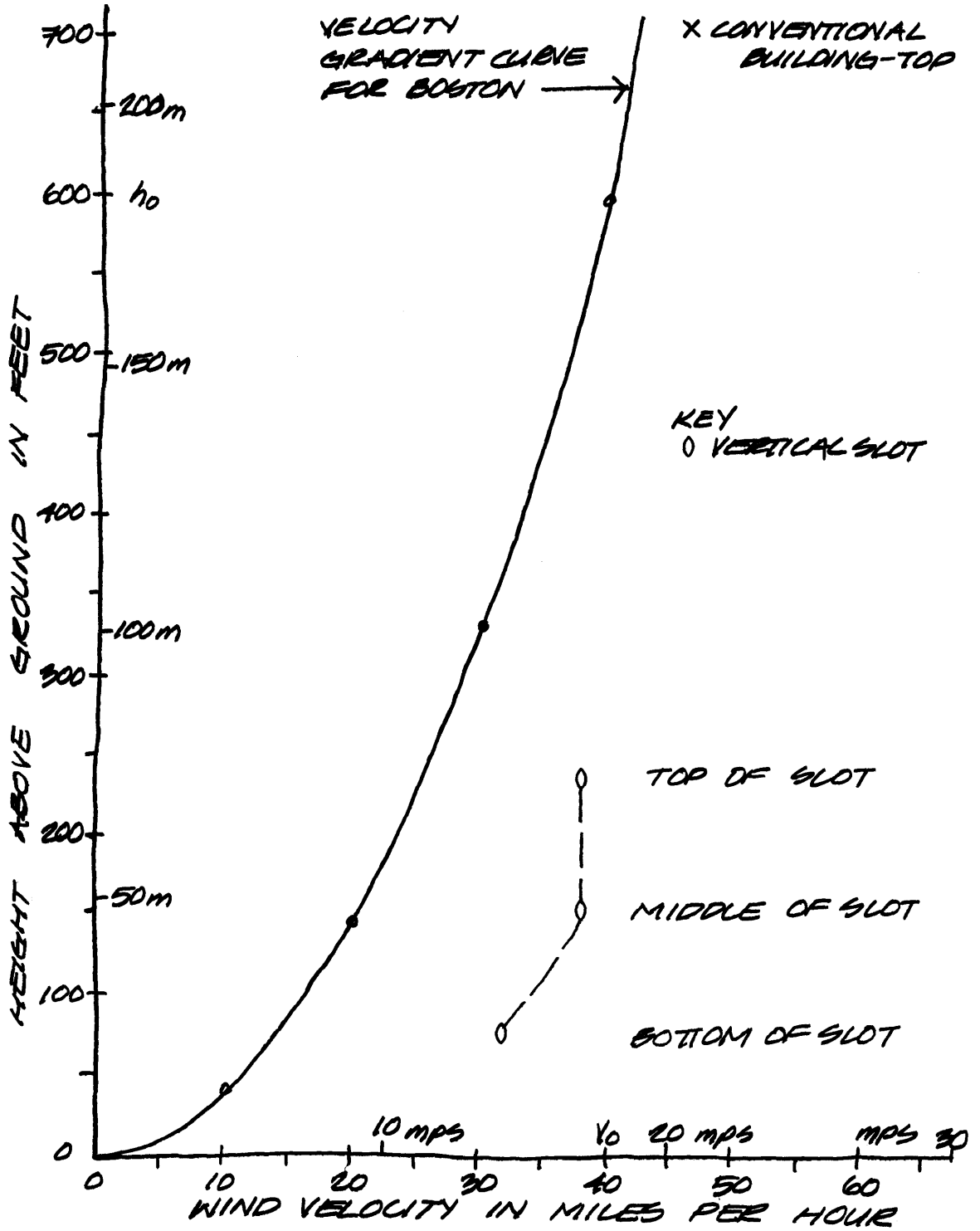

VERTICAL SLOT $\phi = 0^\circ$
 VELOCITY INCREASE RESULTS FIGURE 23
 71

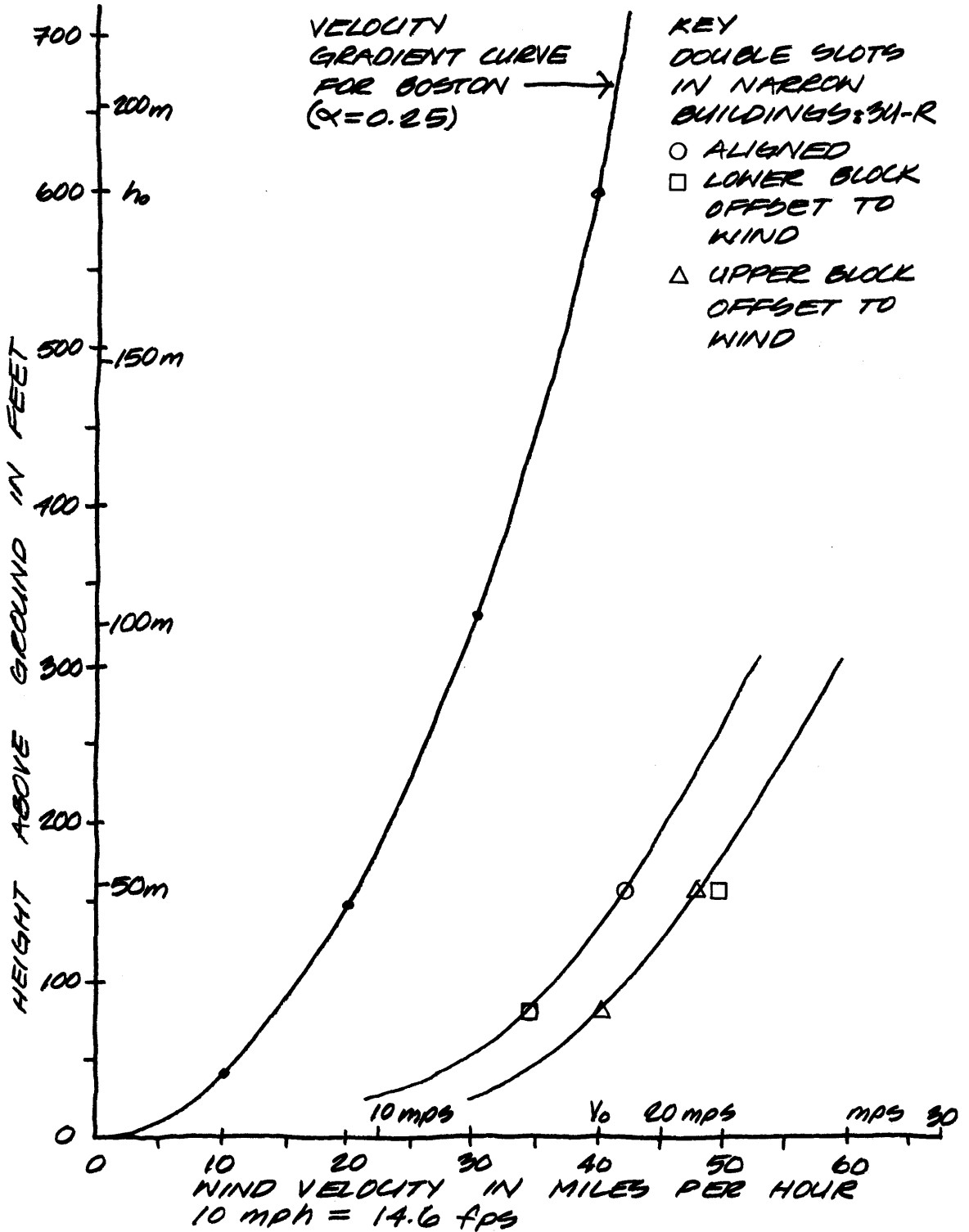

DOUBLE-SLOTS IN NARROW BUILDING $\psi = 0^\circ$
 VELOCITY INCREASE RESULTS FIGURE 24

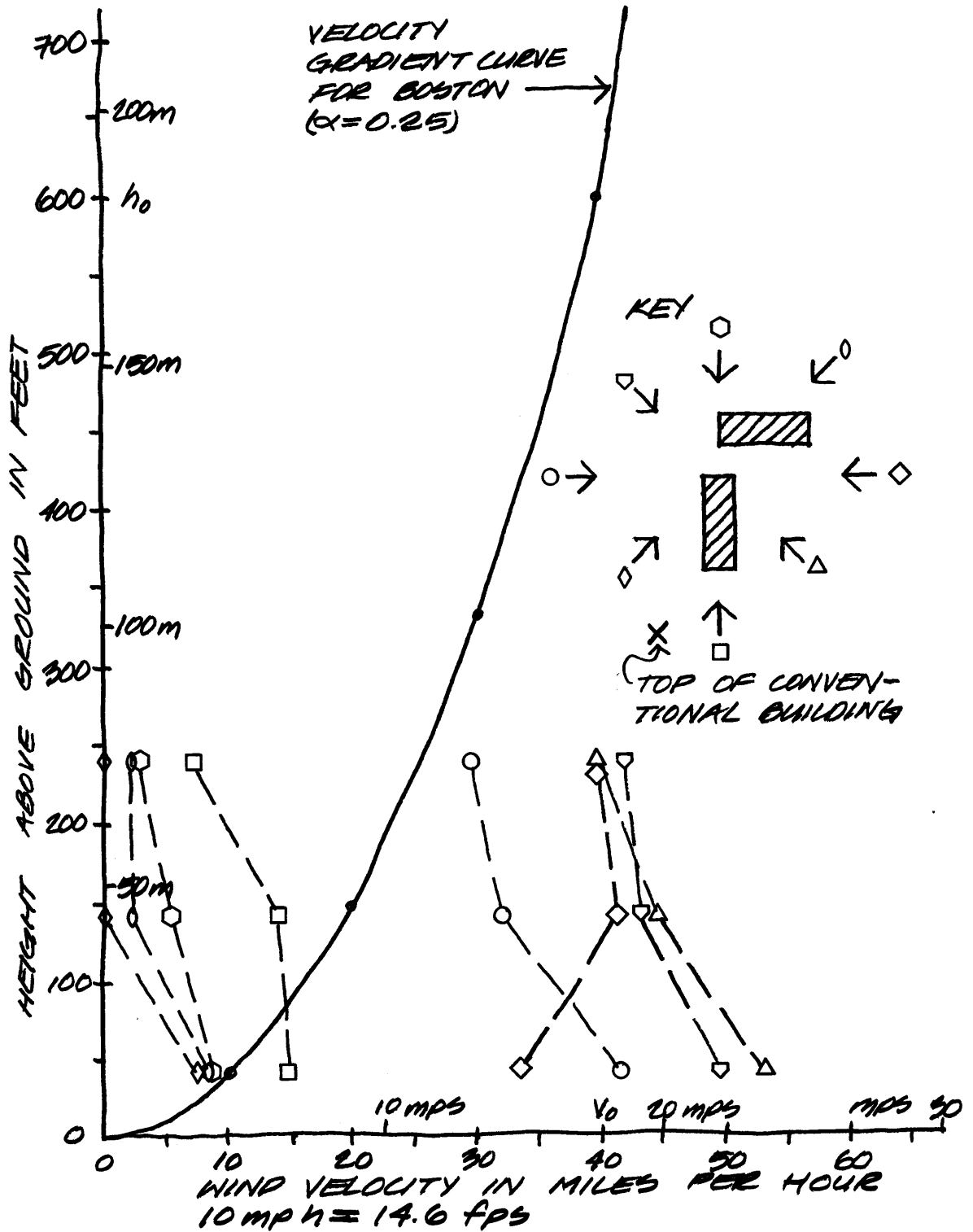

PRUDENTIAL APARTMENTS
 BOSTON, MASSACHUSETTS
 VELOCITY INCREASE/DECREASE

FIGURE 25

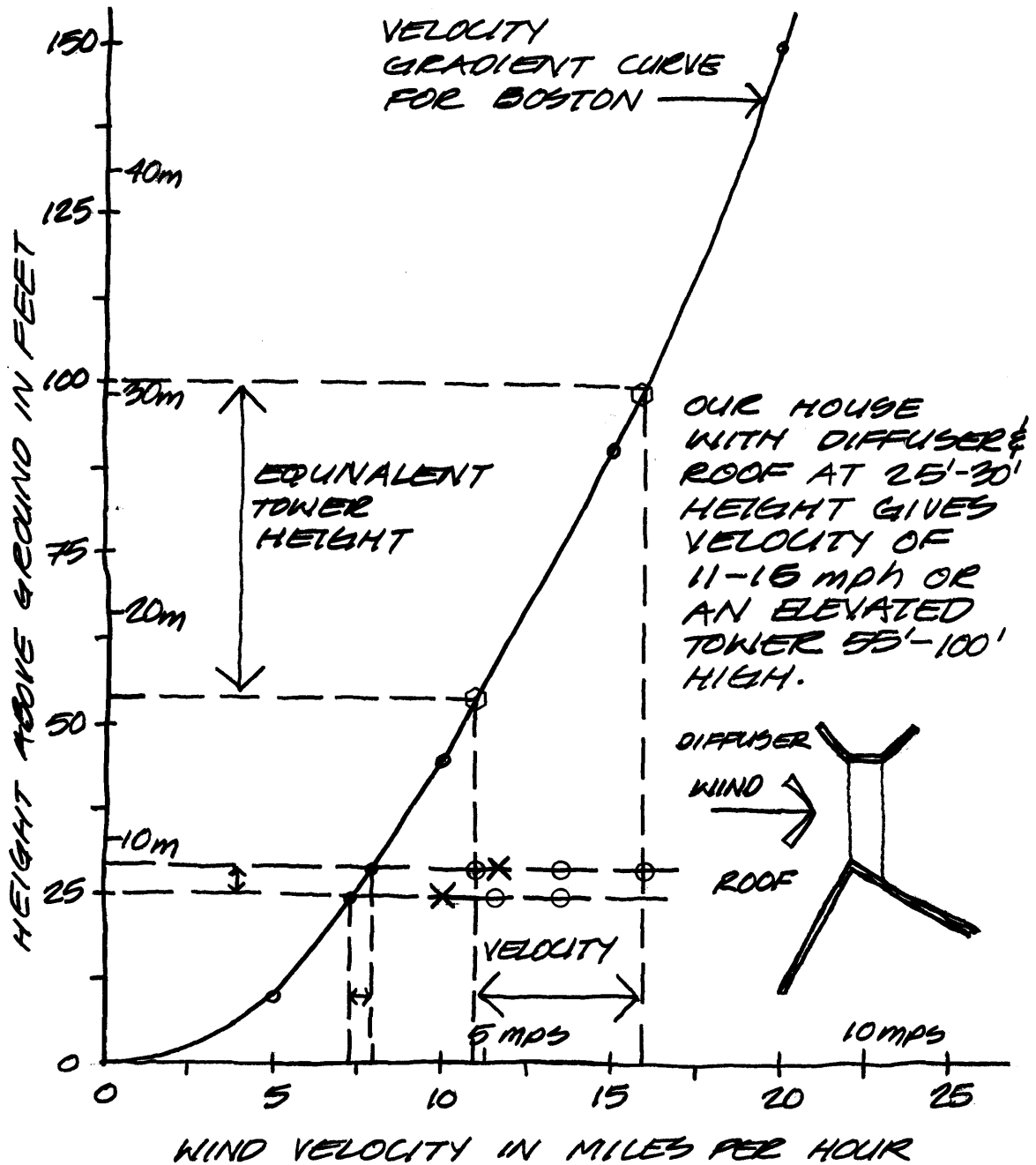

- VELOCITY AT 25' HEIGHT WITHOUT HOUSE OR DIFFUSER IS 7-8 mph.
- VELOCITY OVER ROOF AT 25' WITH HOUSE AND NO DIFFUSER IS 10-12 mph.

$\varphi = 0^\circ$
 SMALL HOUSE WITHOUT DIFFUSER X
 SMALL HOUSE WITH DIFFUSER O
 VELOCITY INCREASE RESULTS

FIGURE 26

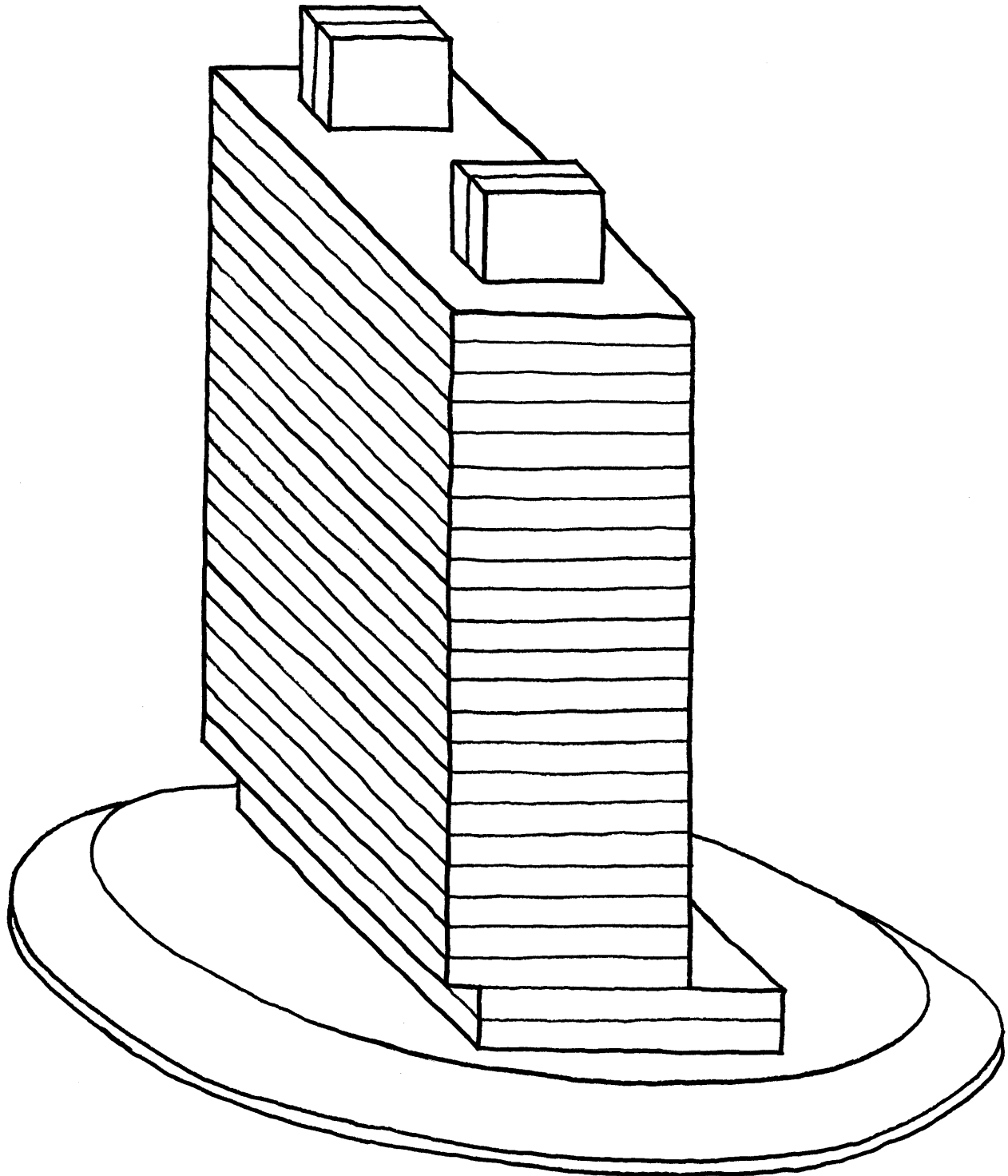

CONVENTIONAL BUILDING

FIGURE 27

OPENING SHAPE		SLOT ELEVATION			SLOT FACTOR			
OPEN RECTANGLE		28 UNITS			1.5			
VTC	VTE	VSC	VSE	VME	VBC	VBE		ψ°
3.5	2.8	3.5	2.8	2.6	1.0	2.7		0°

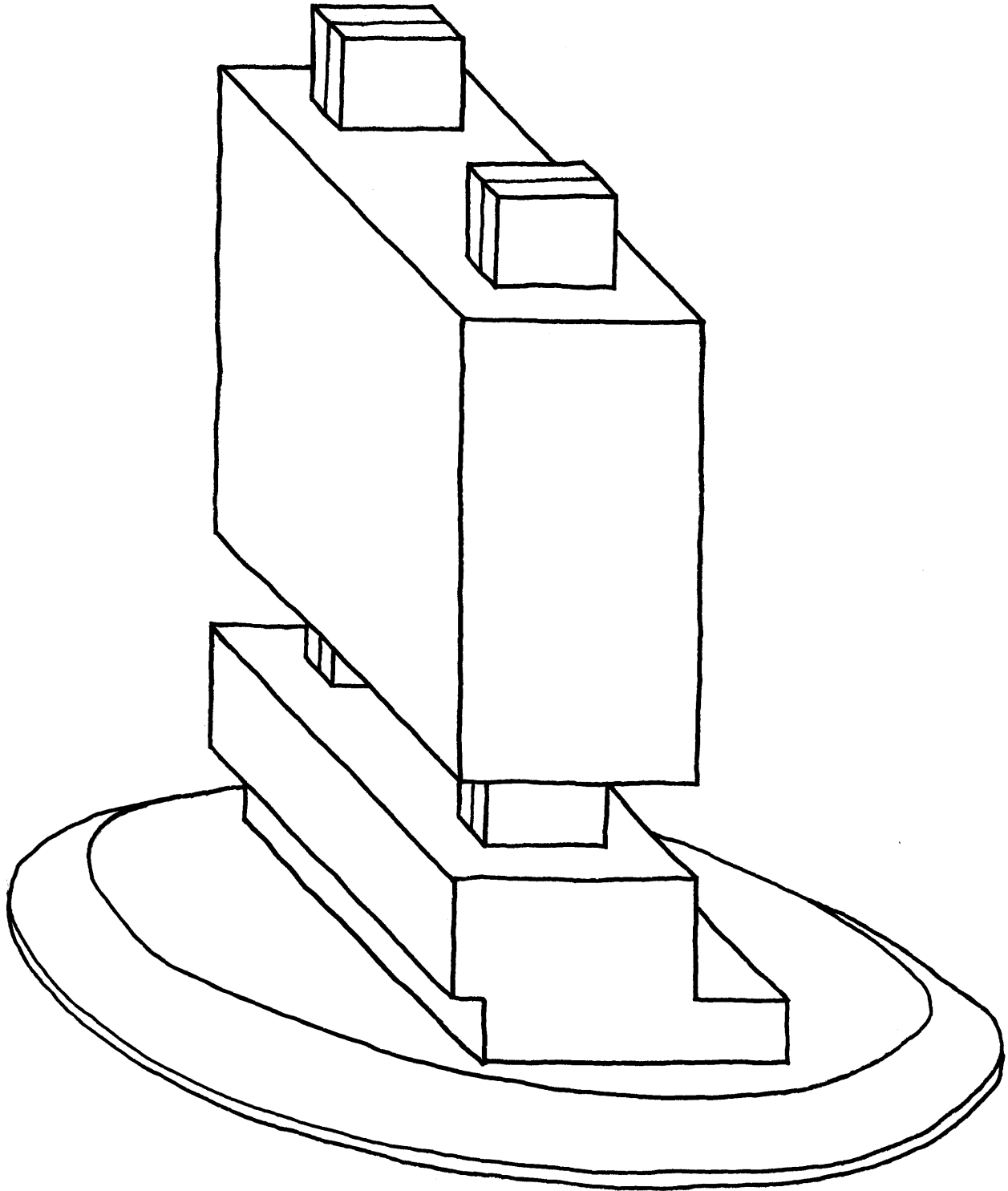

FIGURE 28

SLOT SHAPE		SLOT LOCATION				SLOT FACTOR		
3U-R		7 UNITS				1.4		
VTC	VTE	VSC	VSE	VME	VBC	VBE		φ
3.5	3.1	1.8	2.3	2.7	0.55	2.0		0°

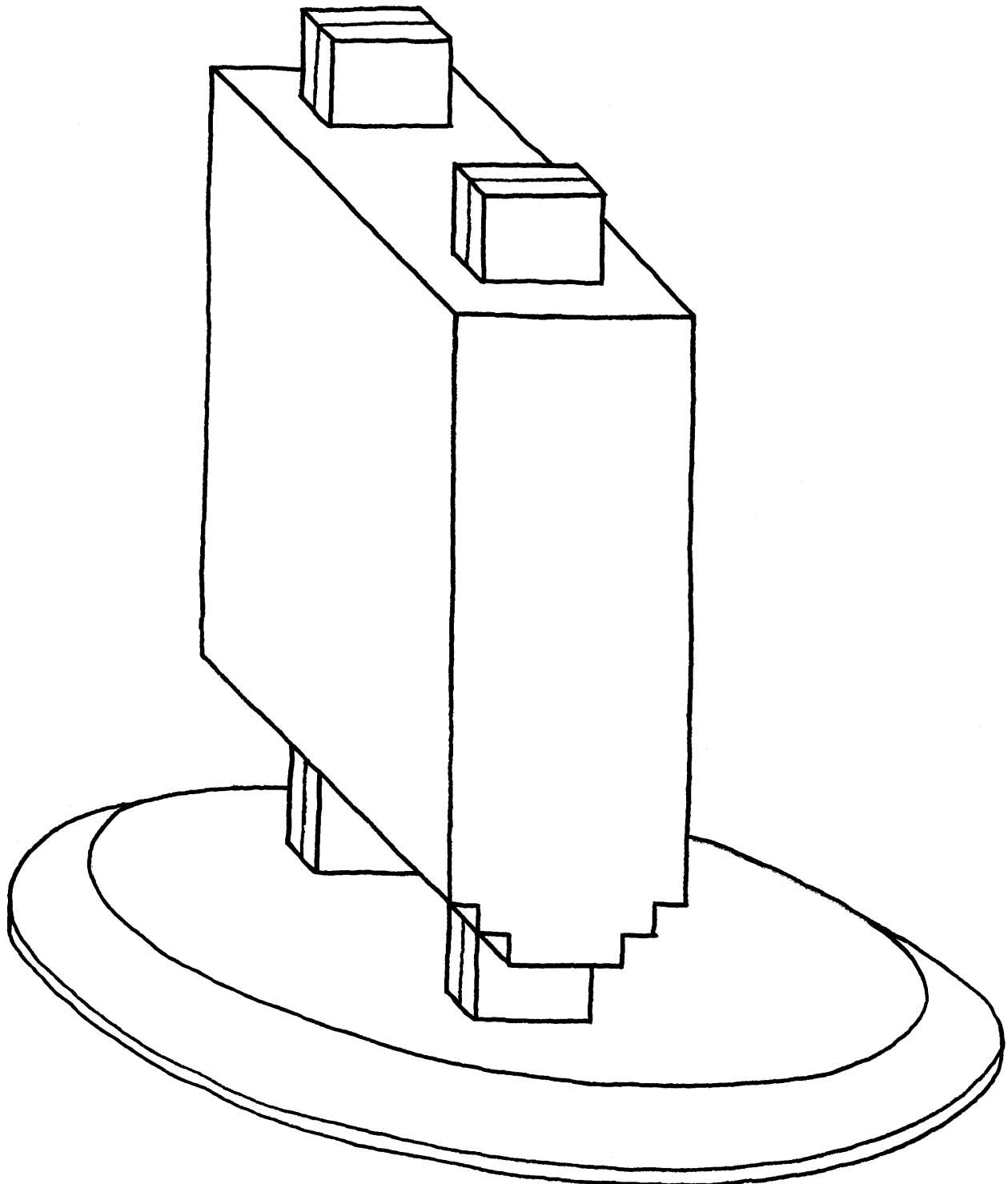

FIGURE 29

SLOT SHAPE		SLOT ELEVATION				SLOT FACTOR		
3U-T/2		1 UNIT				4.4		
VTC	VTE	VSL	VSE	VME	VBL	VBE		φ
2.0	1.8	2.85	2.4	2.5	2.85	2.4		0°

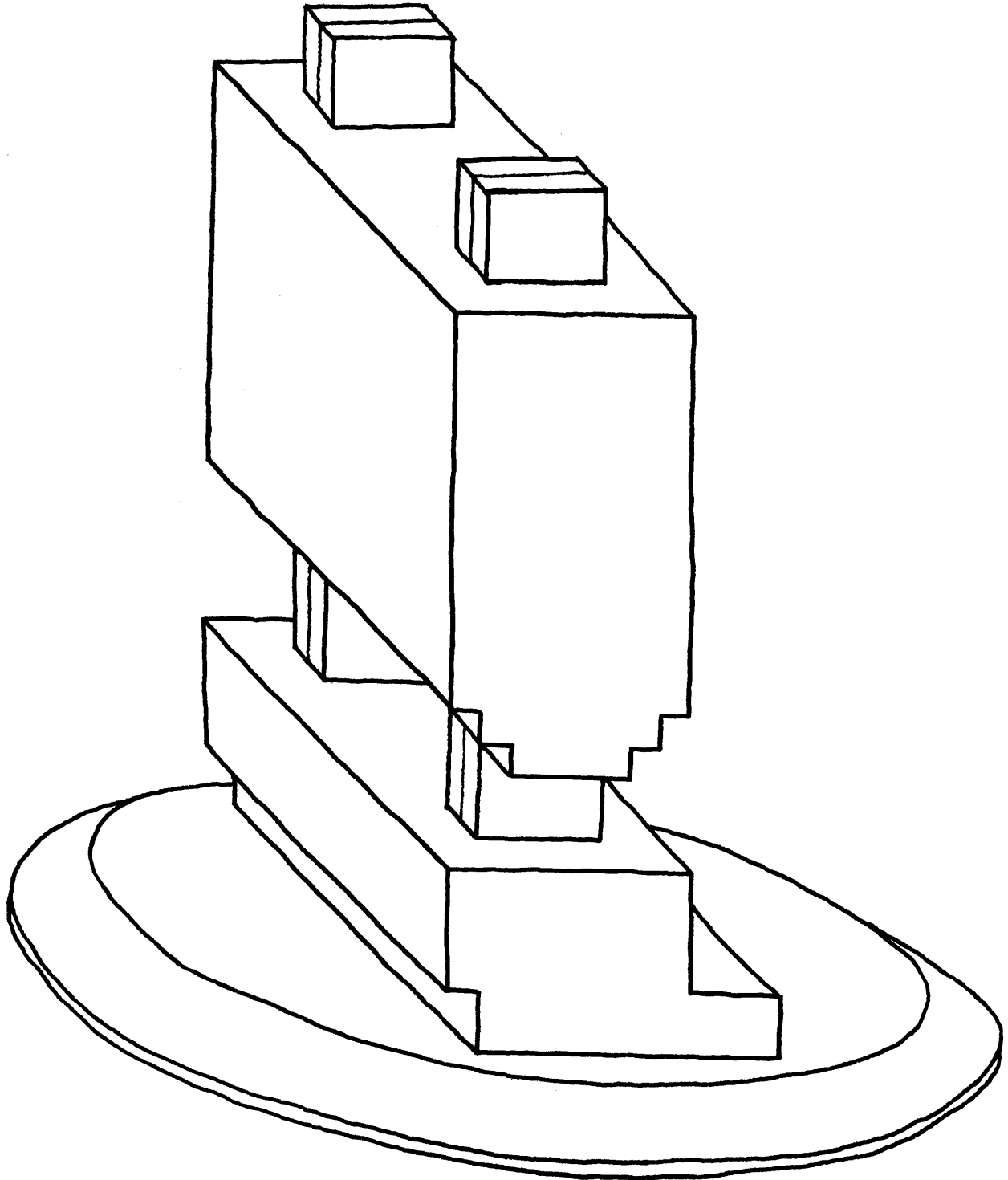

FIGURE 30

SLOT SHAPE			SLOT ELEVATION			SLOT FACTOR		
3U-T/2			7U			2.6		
VTC	VTE	V _{SC}	VSE	VME	VBC	VBE		φ
3.5	3.1	3.5	3.0	2.7	0.5	2.7		0°

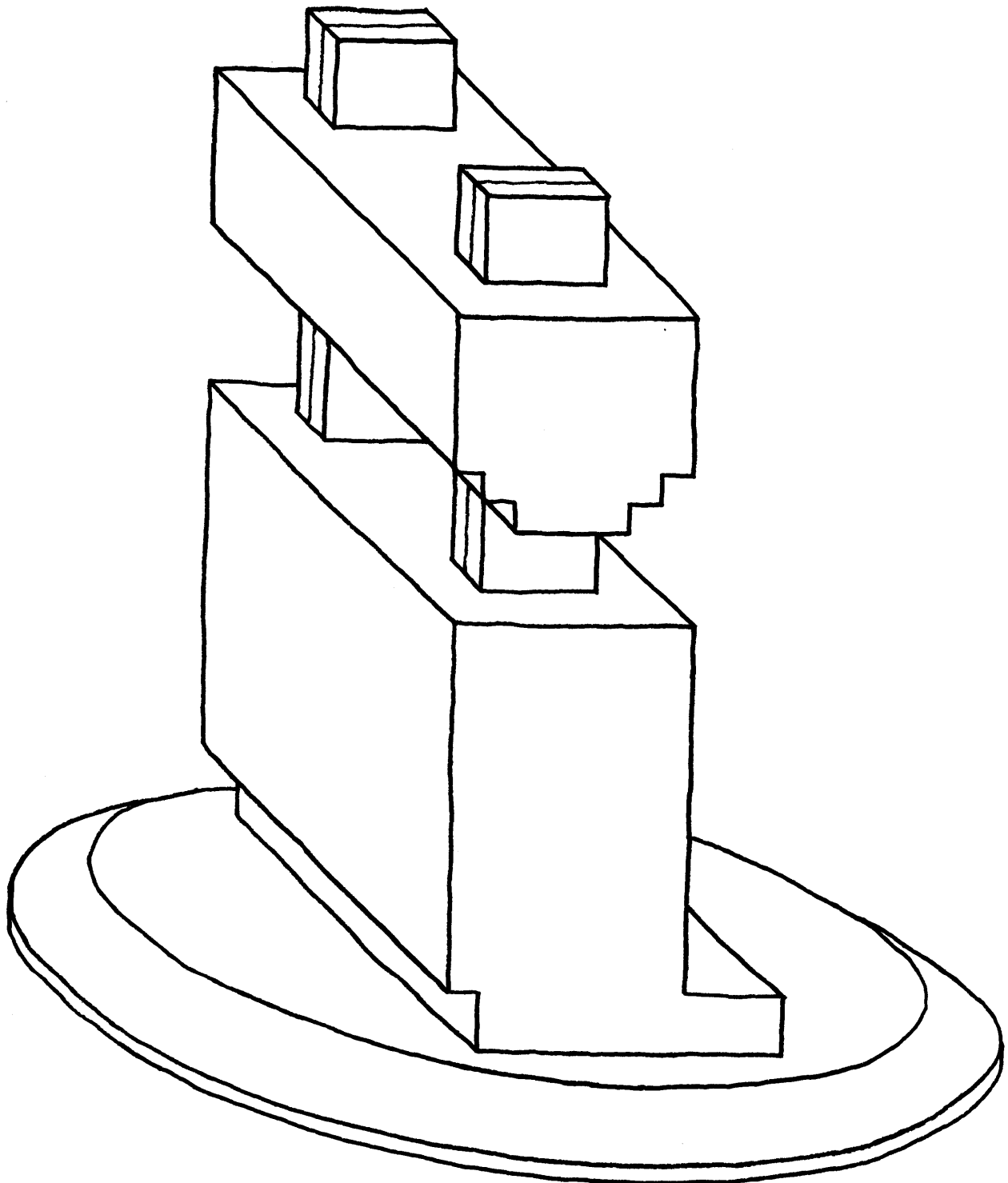

FIGURE 31

SLOT SHAPE			SLOT ELEVATION			SLOT FACTOR		
3U-7/2			14 UNITS			2.0		
VTC	VTE	VSL	VSE	VME	VOL	VBE		φ
3.3	2.7	3.5	2.9	2.2	0.9	2.5		0°

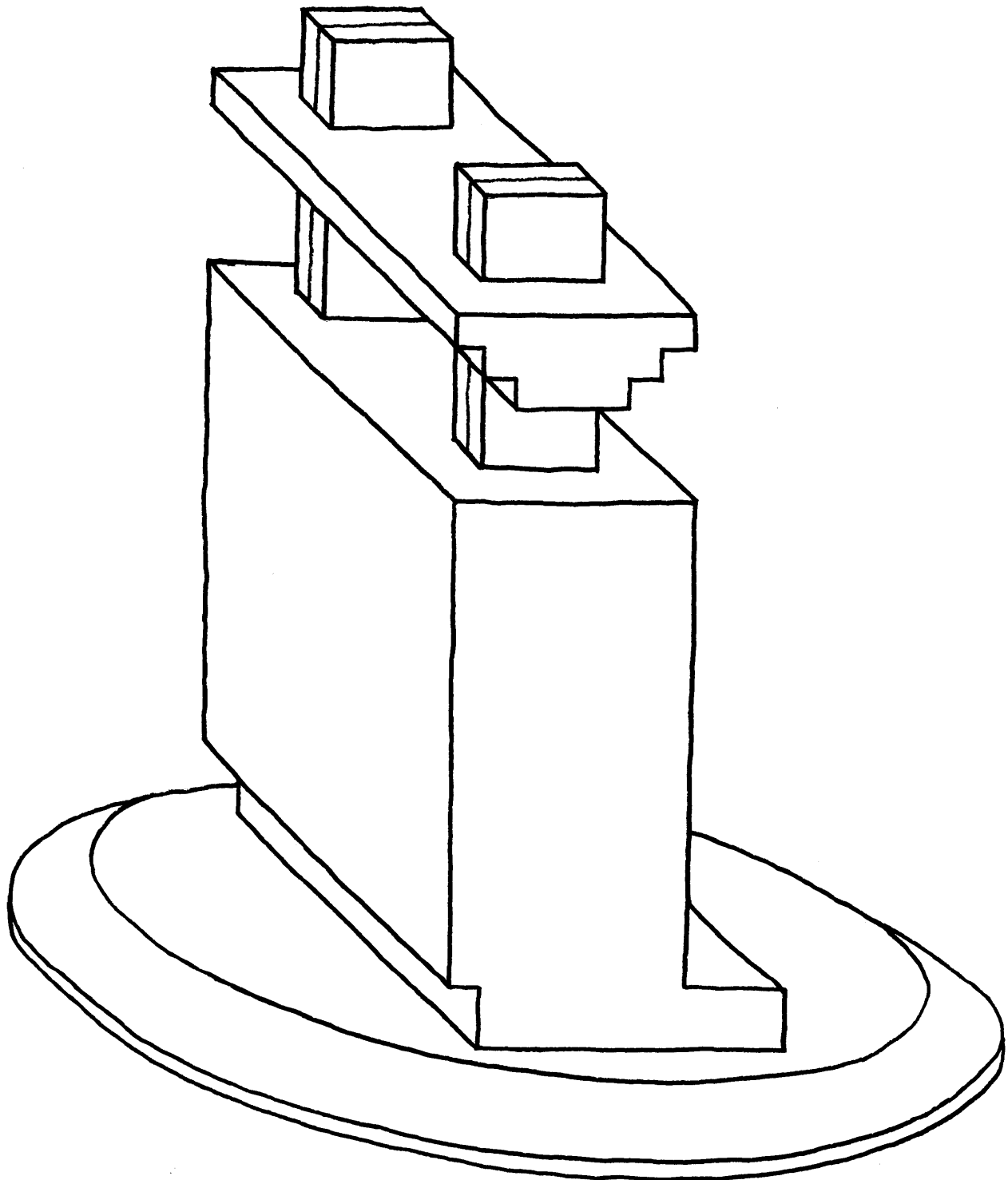

FIGURE 32

SLOT SHAPE			SLOT ELEVATION			SLOT FACTOR		
34-T/2			21 UNITS			1.7		
VTC	VTE	VSC	VSE	VME	VBC	VBE		φ
3.4	3.0	3.8	3.3	2.7	0.9	2.4		0°

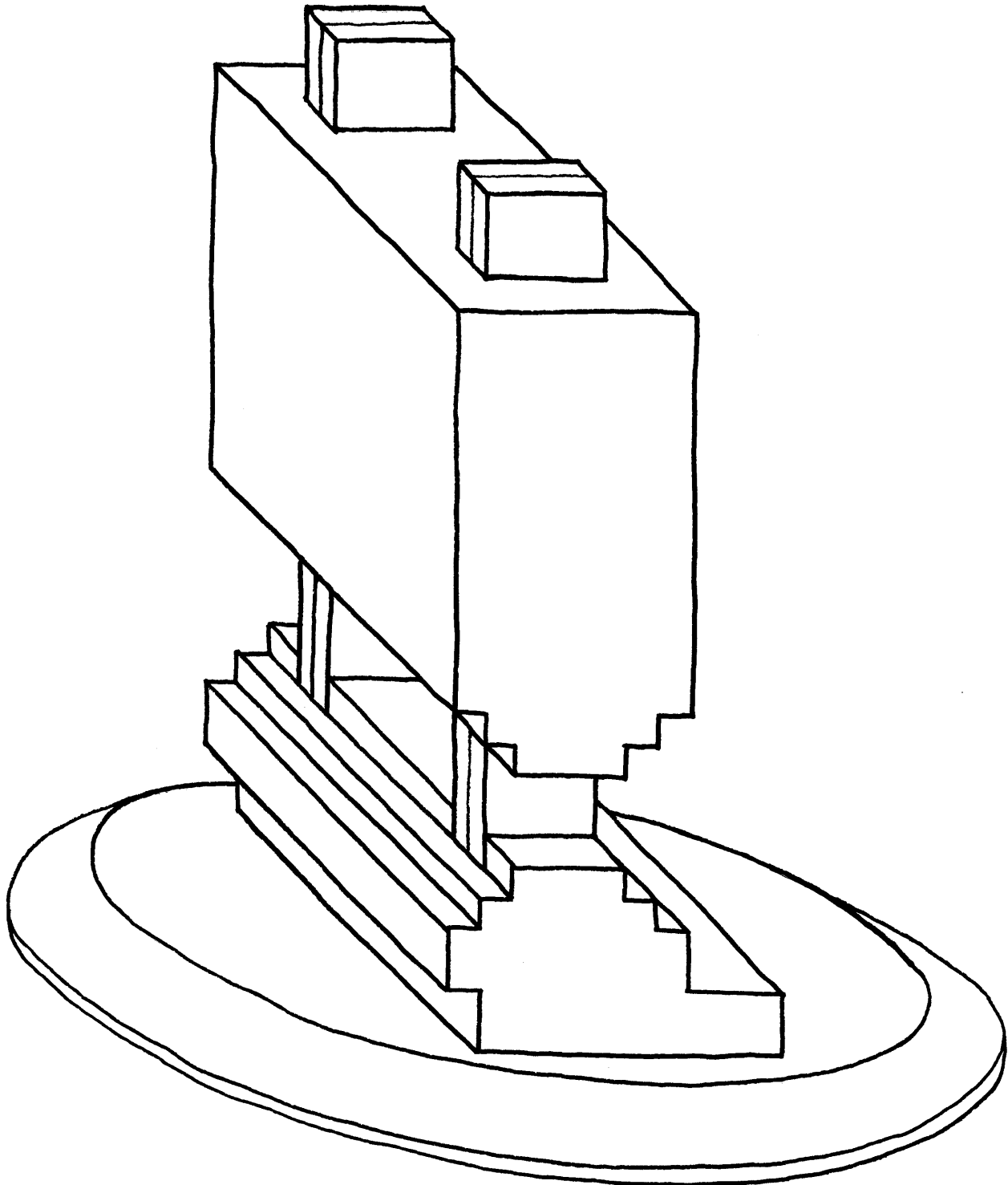

FIGURE 33

SLOT SHAPE			SLOT ELEVATION				SLOT FACTOR	
3U-T			7 UNITS				2.6	
VTC	VTE	VSC	VSE	VME	VBC	VBE		φ
2.6	2.3	3.5	3.2	2.1	0.8	1.9		0°

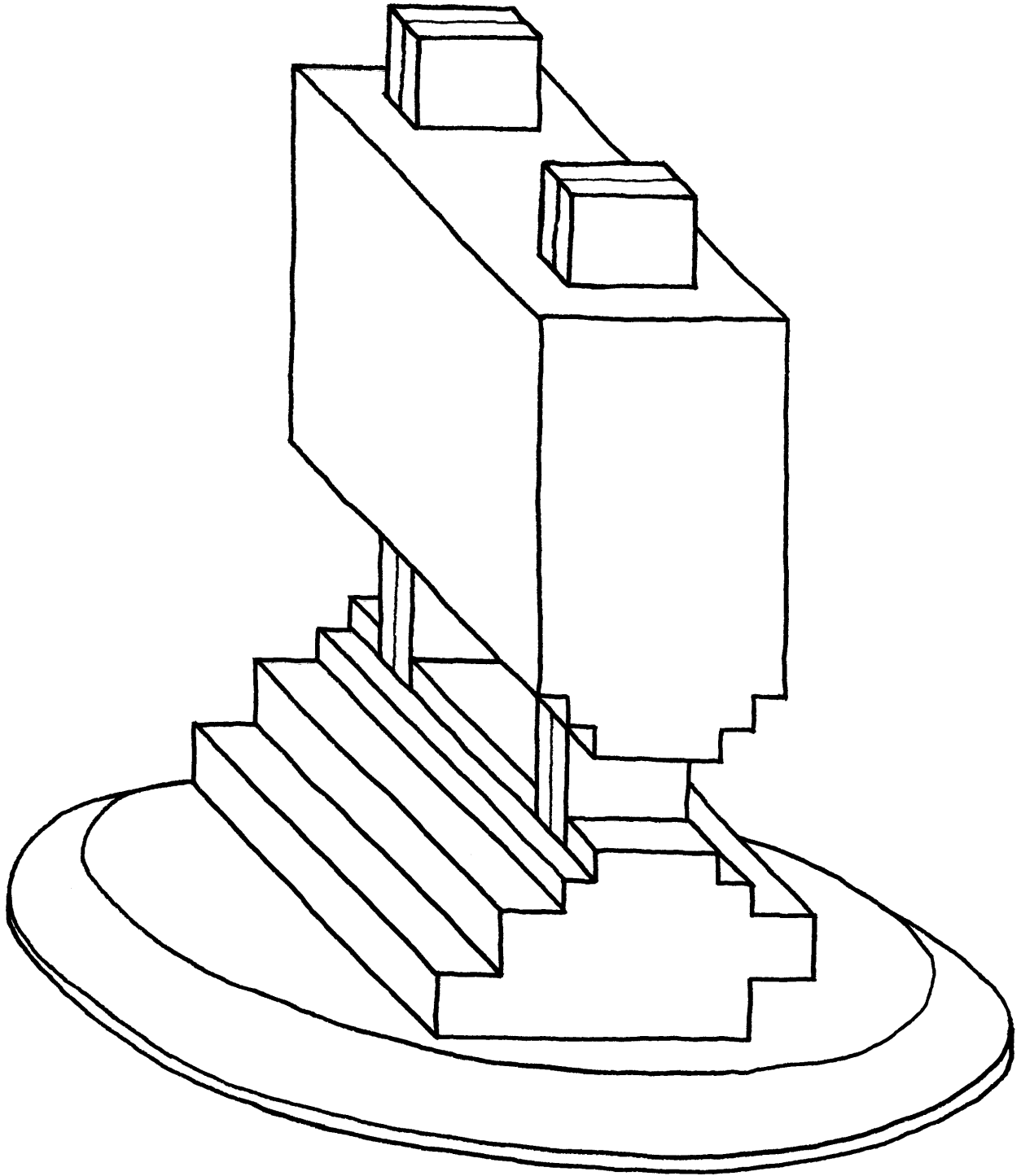

FIGURE 34

SLOT SHAPE		SLOT ELEVATION					SLOT FACTOR	
3U-TAPER		7 UNITS					2.6	
VTC	VTE	VBC	VSE	VME	VOC	VBE		φ
2.5	2.5	3.4	3.1	2.5	0.6	2.4		0°

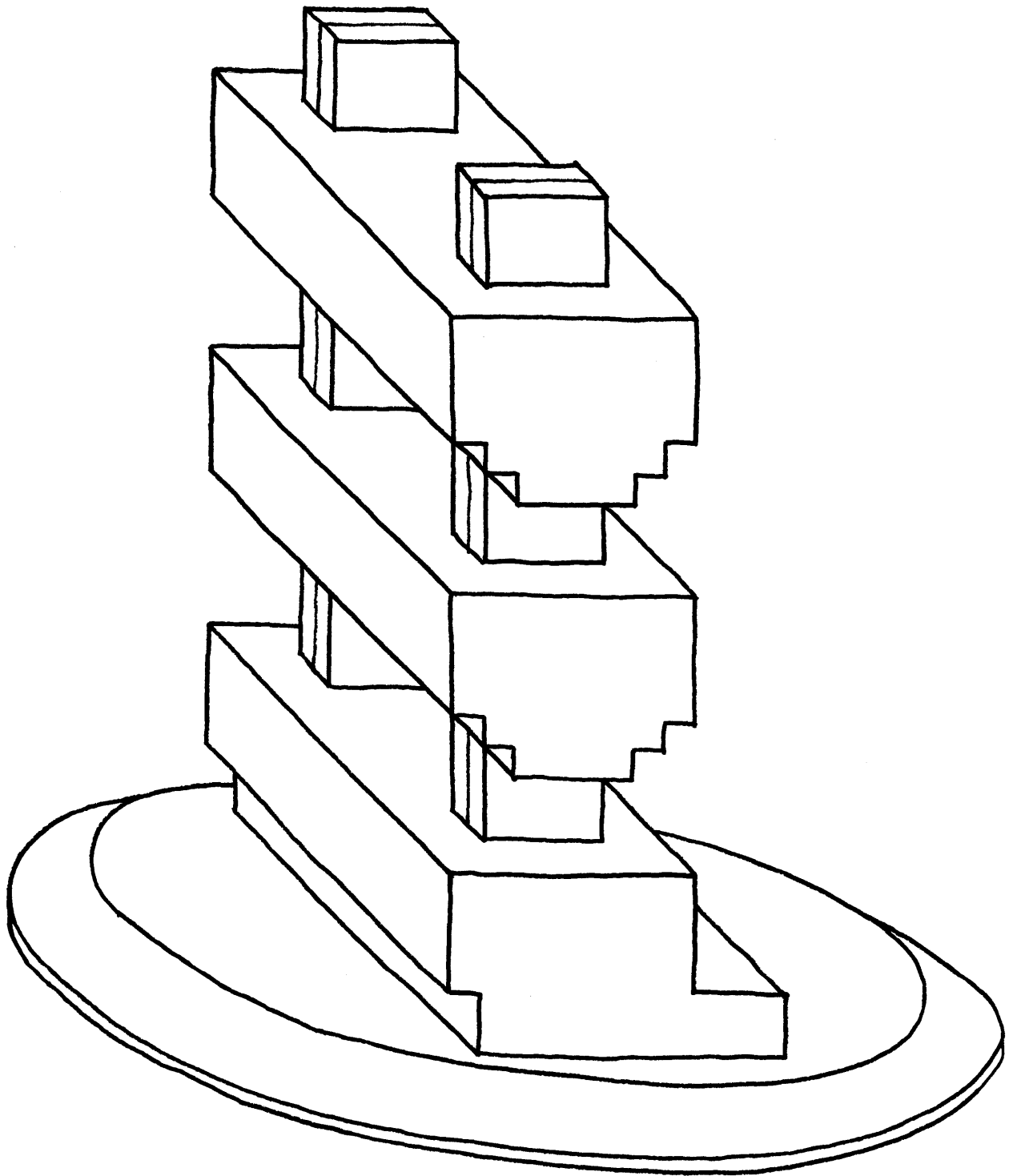

FIGURE 35

SLOT SHAPE			SLOT ELEVATION			SLOT FACTOR		
SU-T/2			7 UNITS	14 UNITS	2.7	2.0		
VTC	VTE	V _{SL}	V _{SE}	VME	VBC	VBE		φ
3.4	3.0	3.9 3.5	3.4 3.0	2.2	0.4	1.8		0°

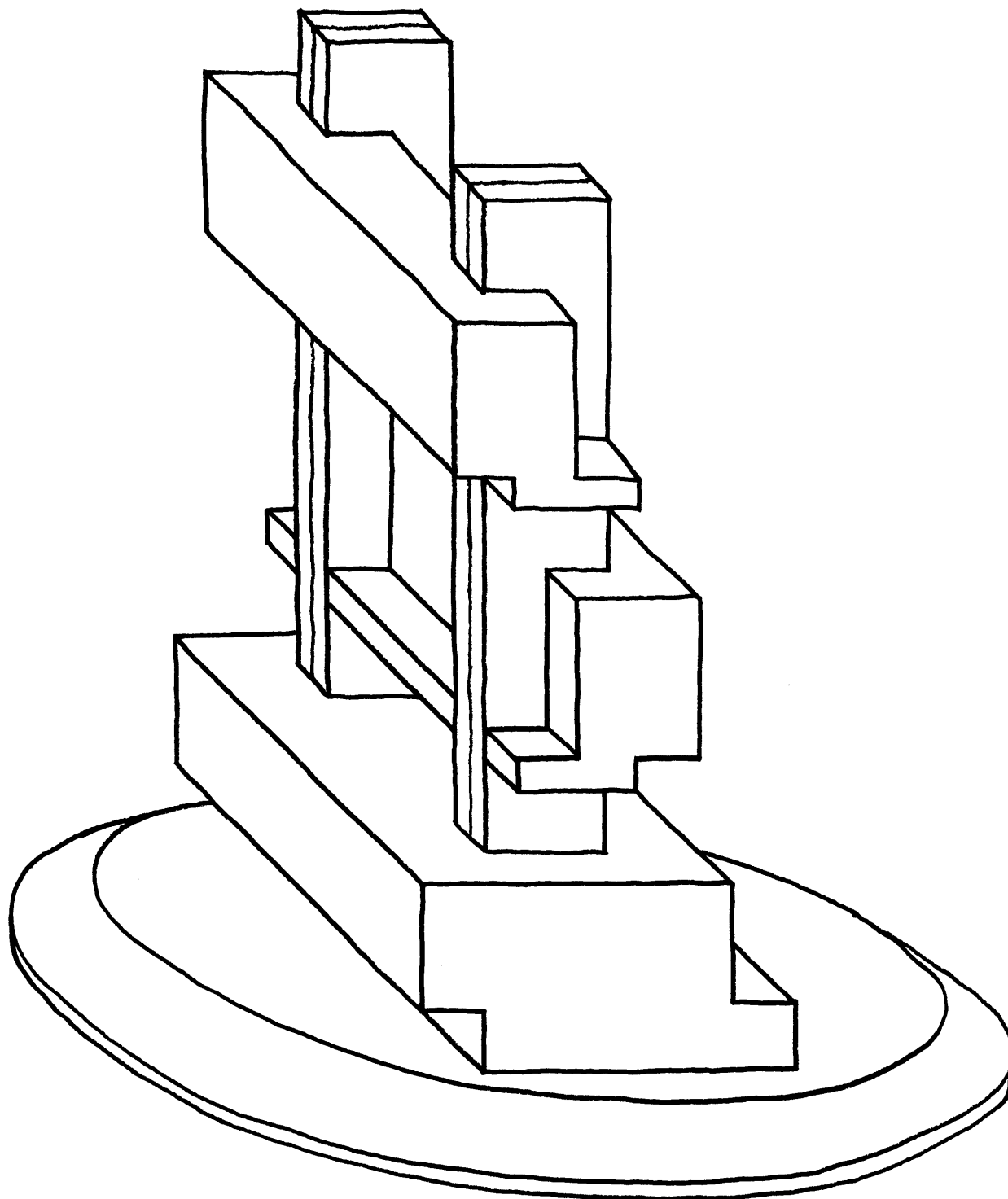

FIGURE 36

SLOT SHAPE		SLOT ELEVATION			SLOT FACTOR			
BU-R		7 UNITS	14 UNITS	2.7	2.3			
VTC	VTE	VSC	VSE	VME	VCL	VBE		φ
3.4	3.4	4.1	3.8	3.8	0.6	1.8		0°

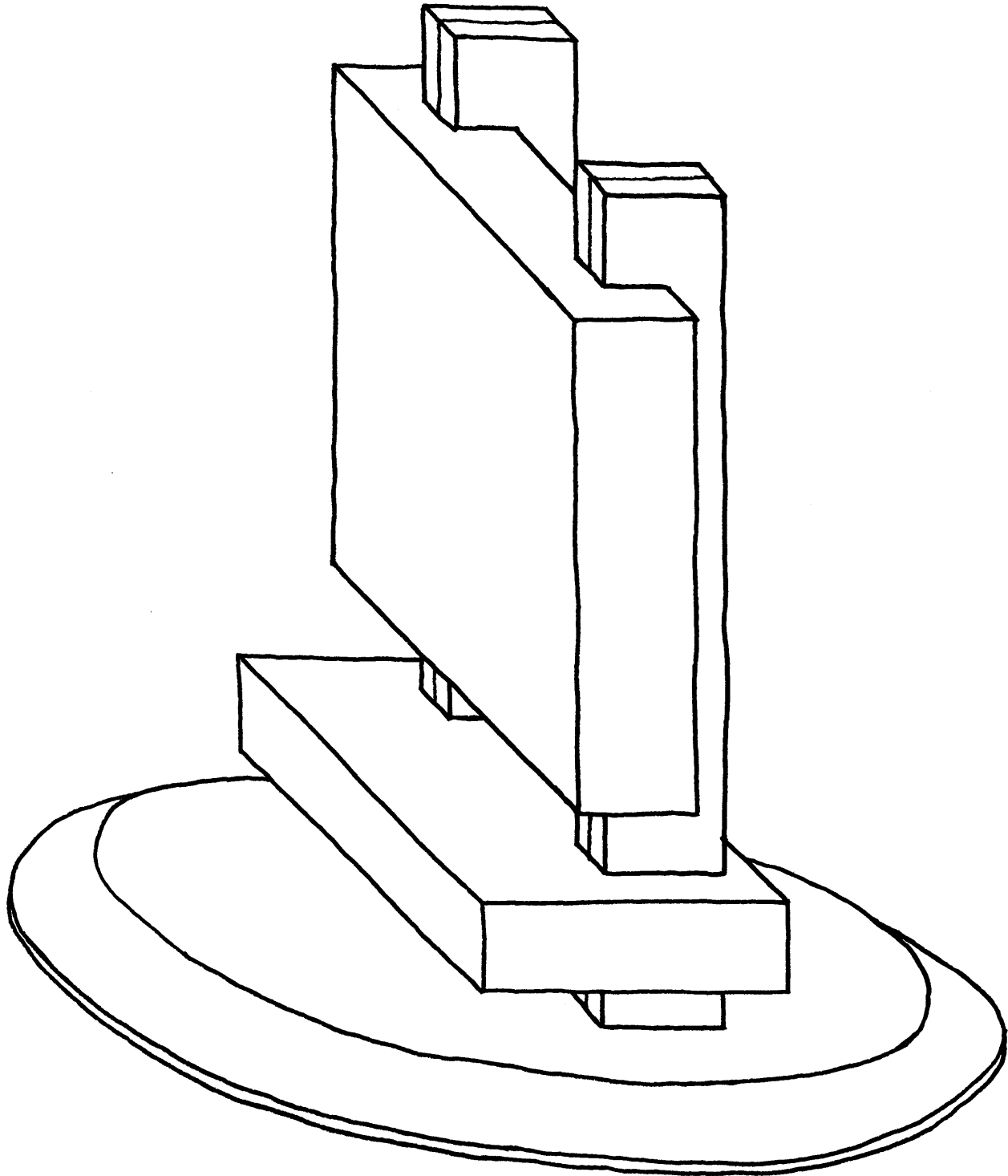

FIGURE 37

SLOT SHAPE			SLOT ELEVATION			SLOT FACTOR		
BU-R			1 UNIT	7 UNIT	3.9	3.9		
V _{TC}	V _{TE}	V _{SL}	V _{SE}	V _{ME}	V _{BL}	V _{BE}		φ
1.3	1.1	3.9	3.4	1.1	1.9	1.4		0°

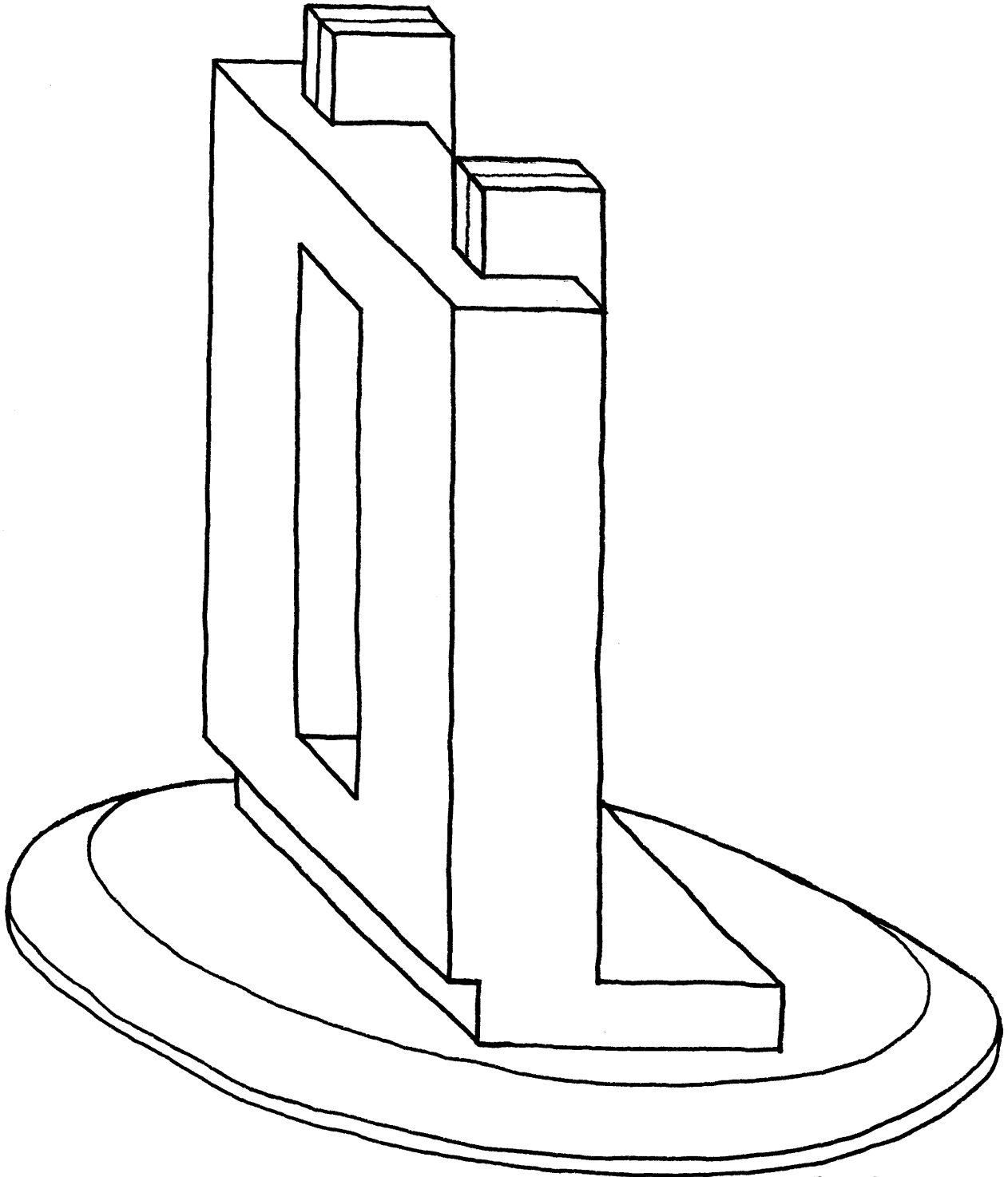

FIGURE 38

SLOT SHAPE			SLOT ELEVATION			SLOT FACTOR		
3U-R, 16UNIT			5U. TO 21U.			2.0		
VTC	VTE	VSC	VSE	VME	VBC	VBE		φ
2.2	2.5	3.0	3.4	2.5	0.5	2.5		0°

SLOT FACTOR	BUILDING SECTION				
3-4					
2-3					
1-2					

HIGH DENSITY

SLOT FACTOR	DIFFUSER SECTION				
1-2					
	TEST	PROPOSED			
	GROUND				

LOW DENSITY

VELOCITY INCREASE AND FORM

FIGURE 39

88

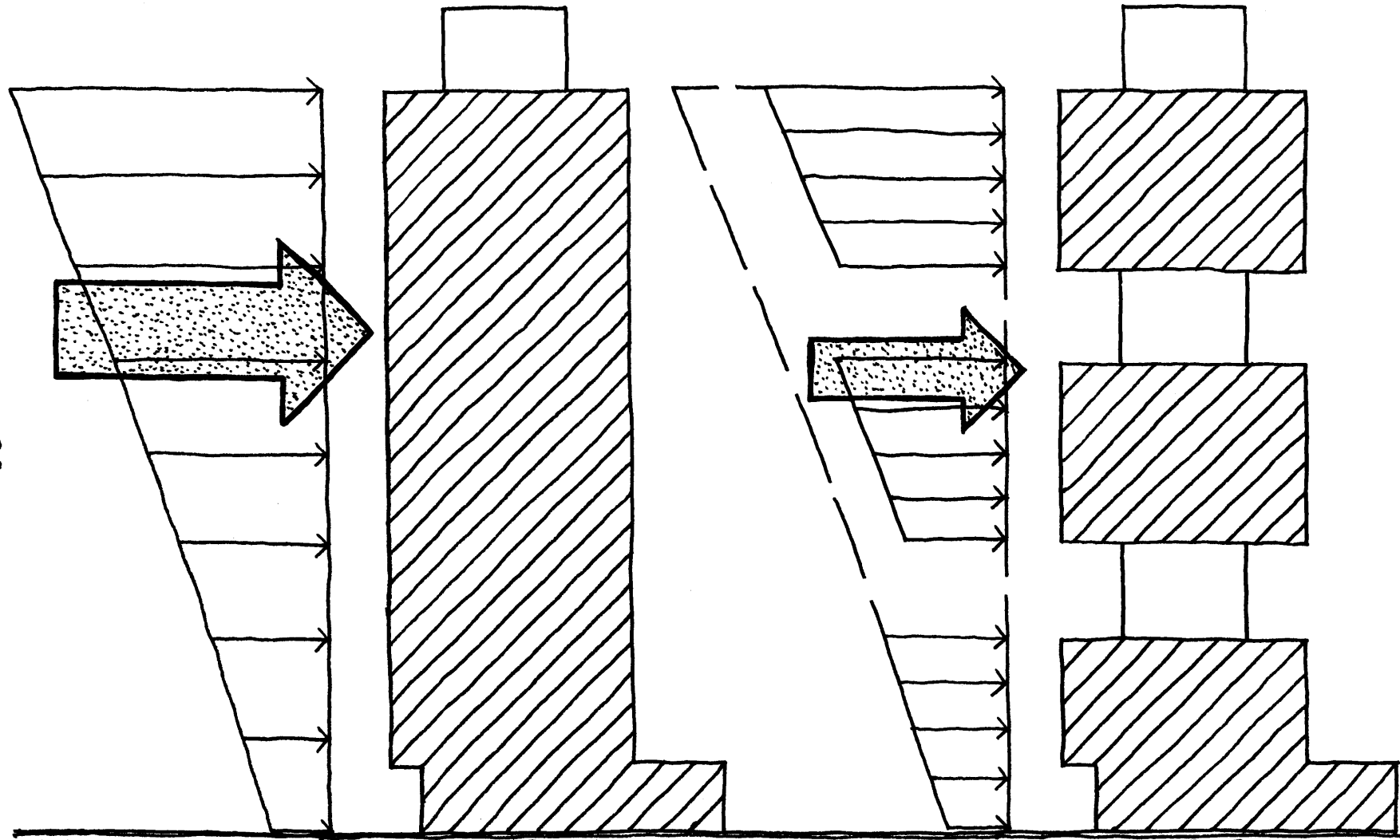

WIND LOAD

CONVENTIONAL BUILDING

WIND LOAD REDUCED

SLOTTED BUILDING

WIND LOADS ON BUILT FORM

FIGURE 40

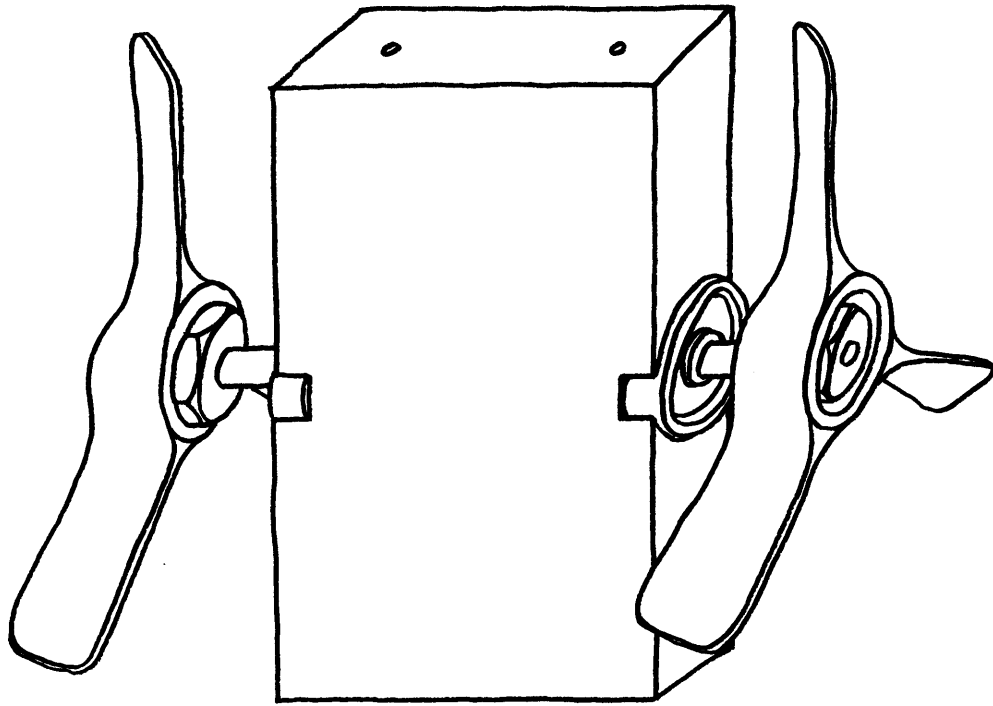

PROPELLOR ROTOR ASSEMBLY

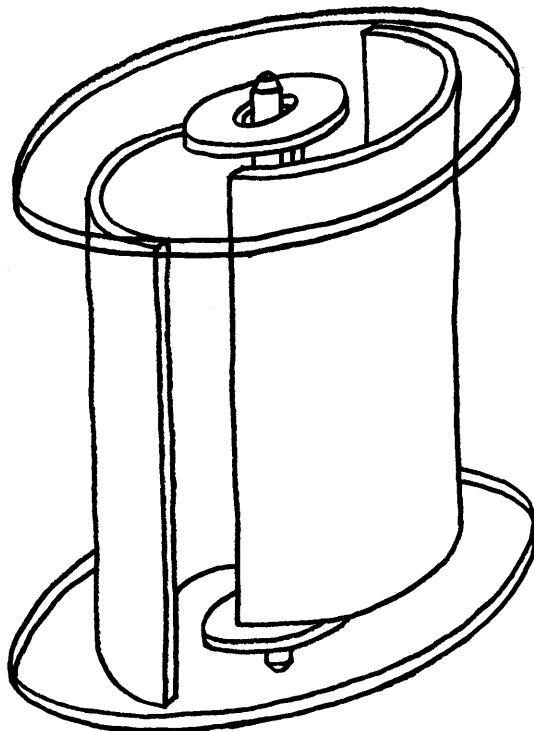

SAVONIUS ROTOR ASSEMBLY
ROTOR ASSEMBLIES

FIGURE 41

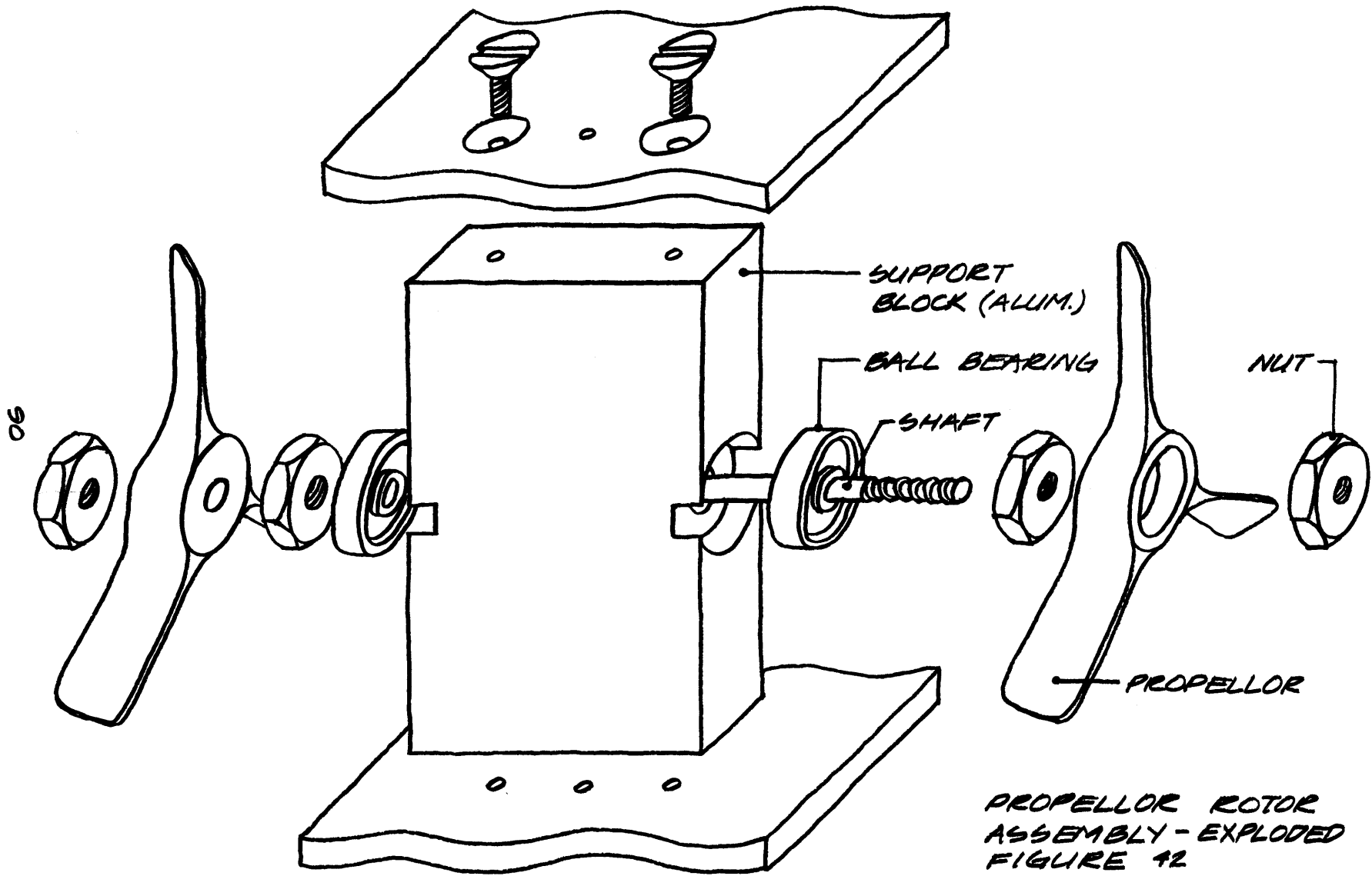

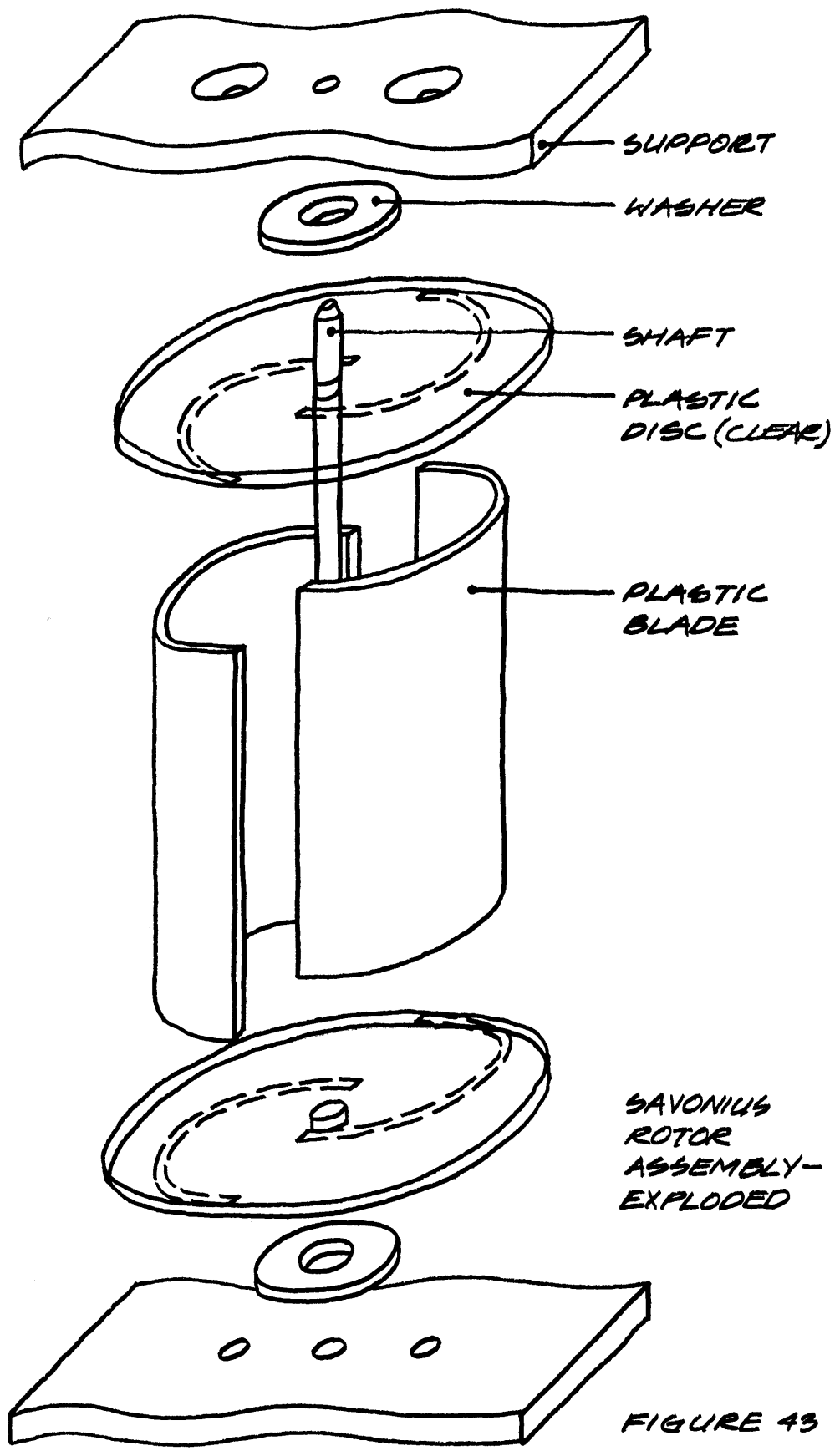
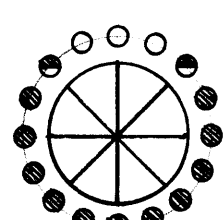
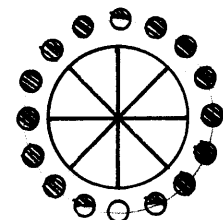
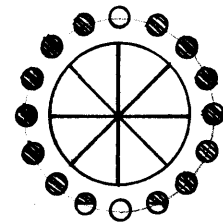
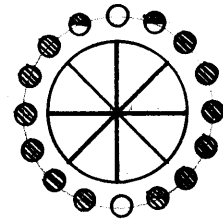
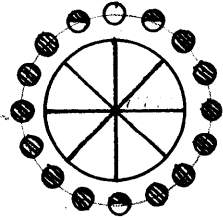
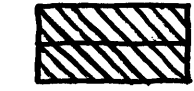
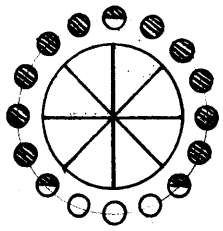
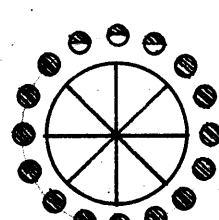
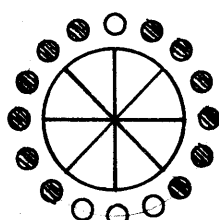
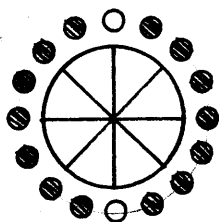
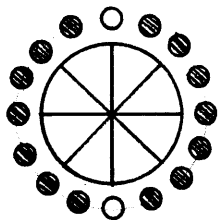
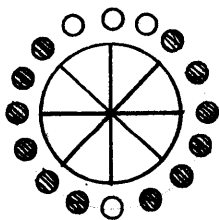
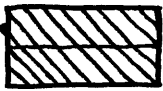
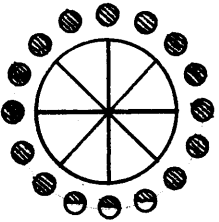

FIGURE 43



COLLECTION CAPACITY FOR FIXED PROPELLOR TURBINE COLLECTORS
 -BASED ON OBSERVATIONS (VISUAL ROTATION) MADE IN WINDTUNNEL.

92



COLLECTION CAPACITY FOR FIXED SAVONIUS ROTOR COLLECTORS
 -BASED ON OBSERVATIONS MADE IN WIND TUNNEL.

KEY TO SYMBOLS

- WIND ROSE INDICATES LOCATION OF COLLECTOR AND DIRECTION OF WIND
- FULL ROTATION OF COLLECTOR = HIGH SPEED
- PARTIAL ROTATION OF COLLECTOR = SLOW SPEED
- NO ROTATION OF COLLECTOR = FULL STOP
- FIXED COLLECTOR
- COLLECTION CAPACITY DUE TO WIND DIRECTION

FIGURE 44

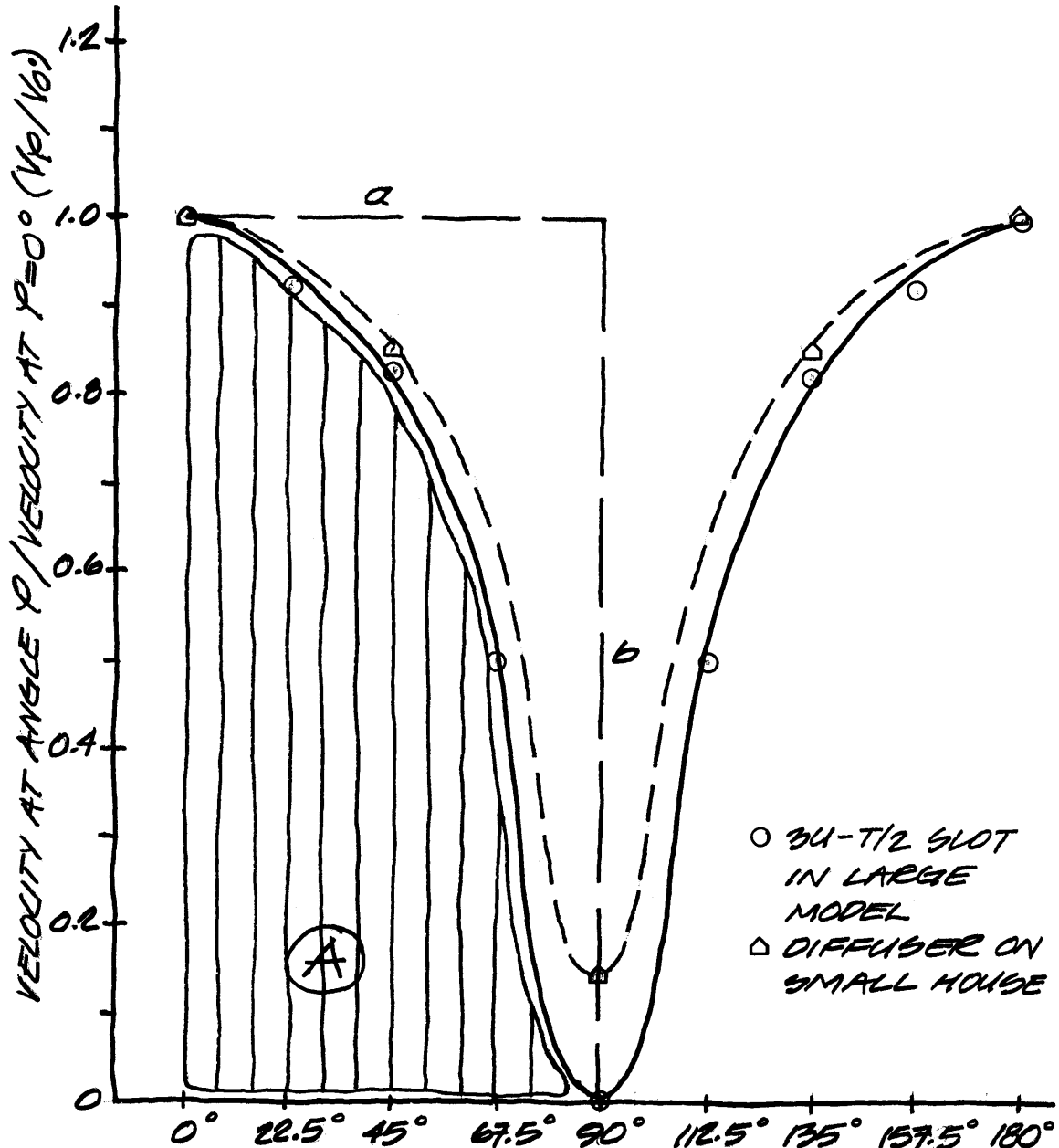

ϕ = ANGLE BETWEEN WIND DIRECTION AND SLOT AXIS MEASURED IN DEGREES

THE AREA **A** UNDER THE VELOCITY CURVE IS EQUAL TO 2/3 THE AREA OF THE RECTANGLE REPRESENTING A CONSTANT VELOCITY OF 1.0 FROM 0°-90°. (RECTANGLE a x b).

VARIATION OF SLOT VELOCITY WITH ANGLE OF WIND

FIGURE 45



LOOKING INTO THE WIND
NOTICE THE TALL SPIRES WHICH SIMULATE
HIGH ALTITUDE TURBULENCE AND RANDOM
BLOCKS WHICH SIMULATE GROUND LEVEL
TURBULENCE.

THE MODEL IS SET FOR $\psi = 67.5^\circ$.

INFORMATION ABOUT
ACTUAL CONDITIONS THROUGH
WIND TUNNEL SIMULATION.

FIGURE 46

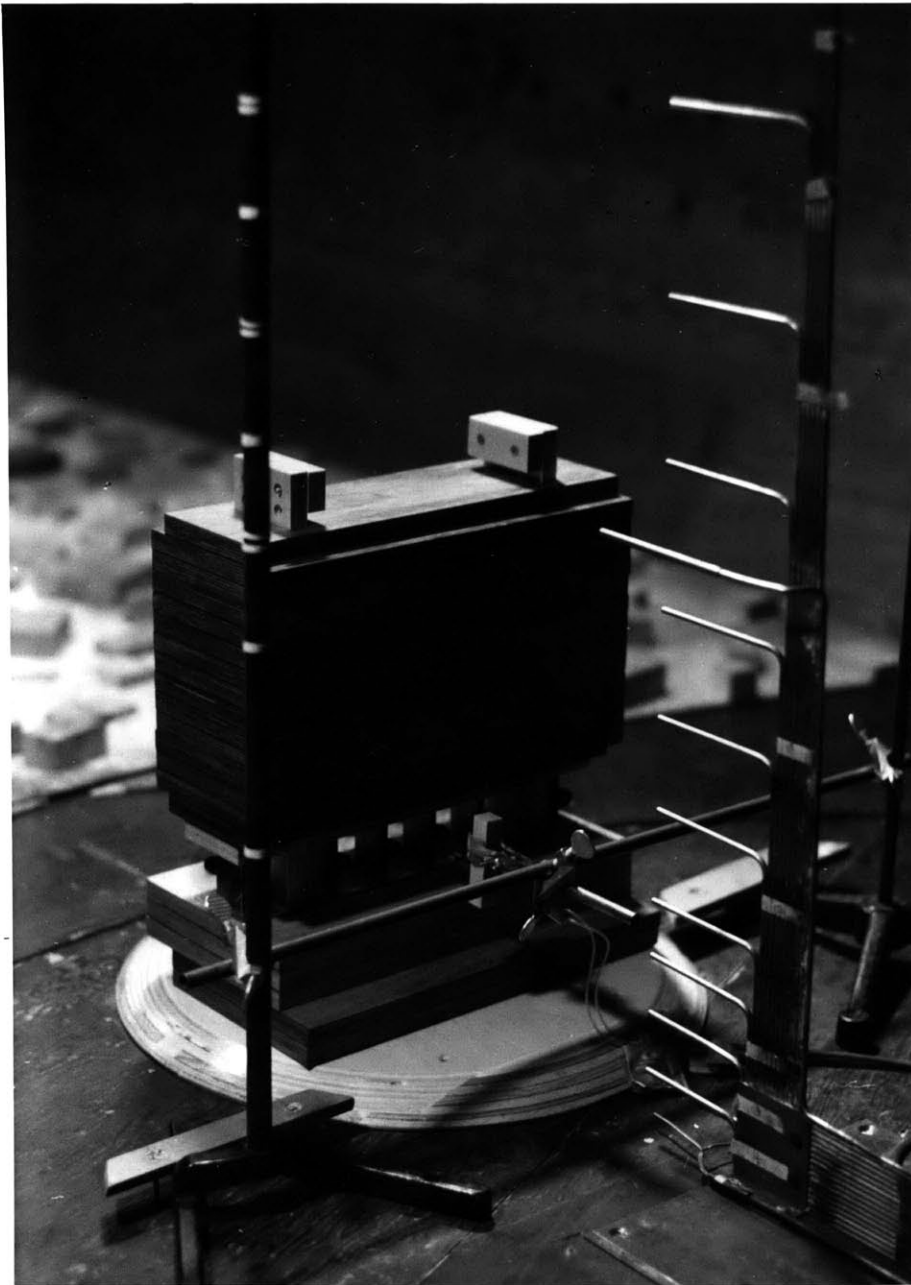

*THE WIND TUNNEL SET UP WITH
MODEL AND TESTING EQUIPMENT* *FIGURE 47*

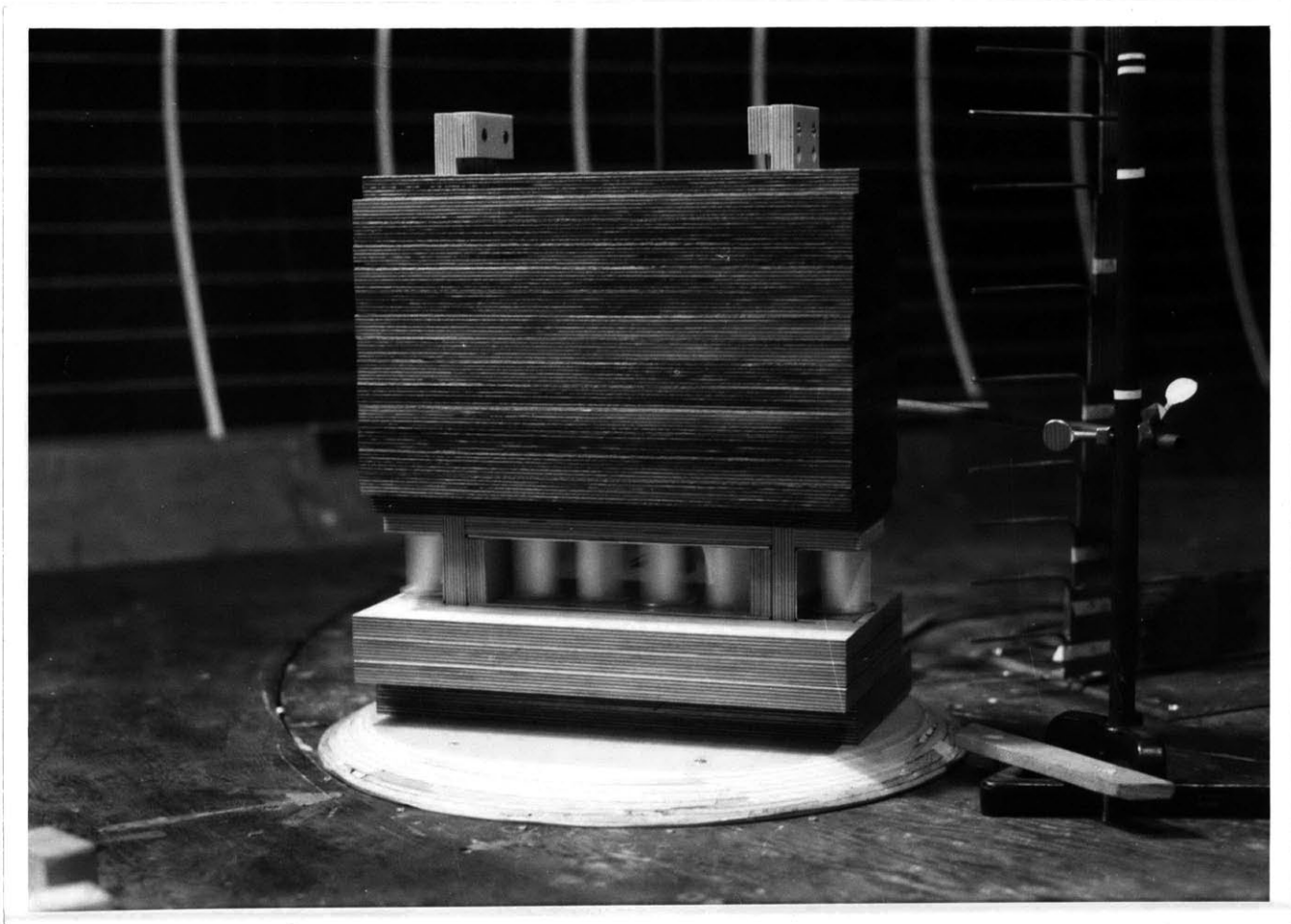

SAVONIUS ROTOR COLLECTOR EXPERIMENT : $\psi = 45^\circ$

FIGURE 48



PROPELLOIR ROTOR COLLECTOR EXPERIMENT : $\varphi = 45^\circ$ FIGURE 49



EXPLANATION
OF FLOW TEST

WIND FLOW IS
DIVERTED DOWNWARD
INTO AND THROUGH
THE OPENING IN
THE MODEL.

FLOW IS IMMEDIATELY
DIFFUSED AS IT
LEAVES THE
LEEWARD SIDE OF
THE SLOT OPENING.
(CLOUD ON RIGHT
SIDE OF LOWER PHOTO)

FLOW TEST
TOP VIEW



FLOW TEST
SIDE VIEW

WIND TUNNEL FLOW TEST

FIGURE 50

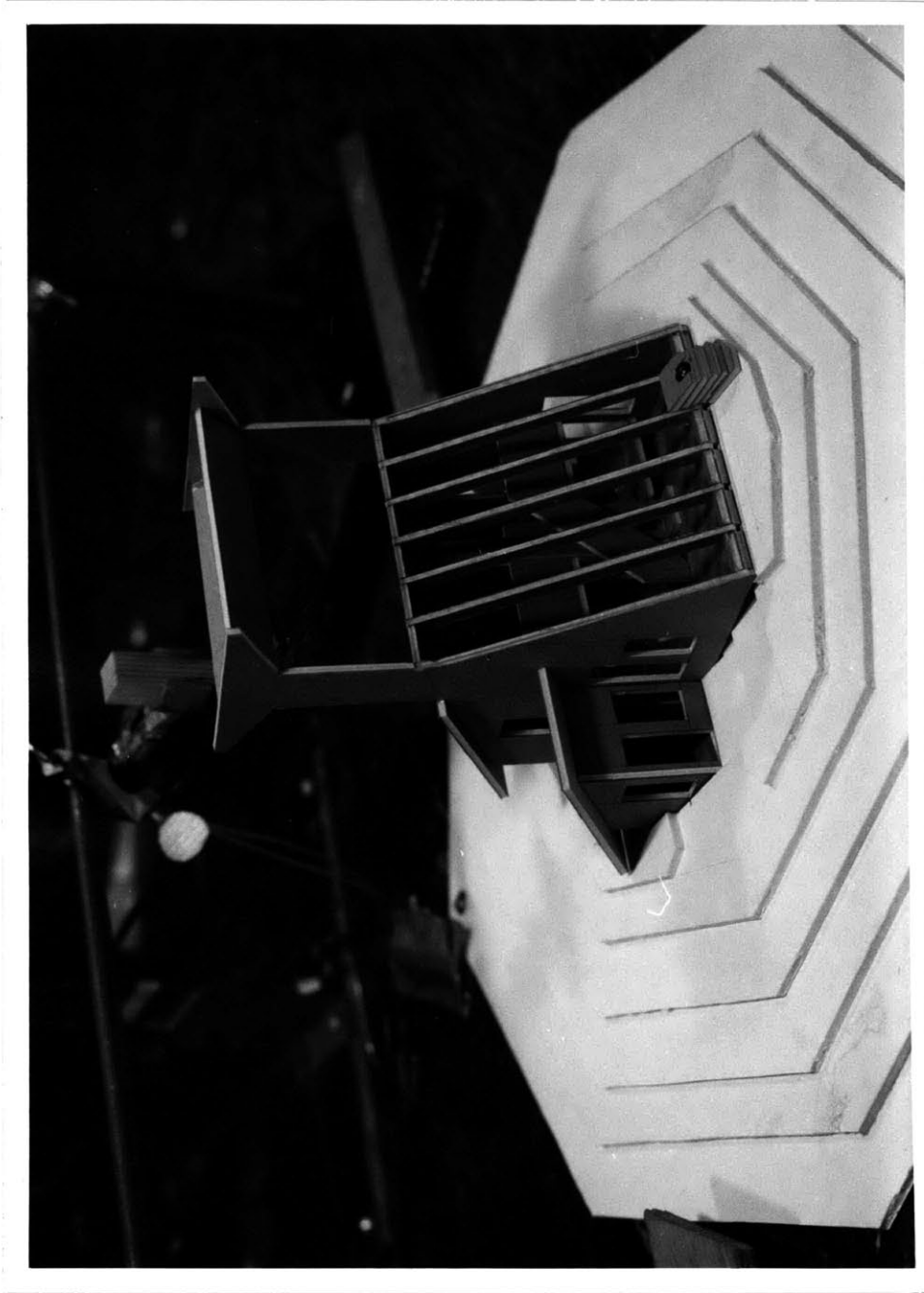
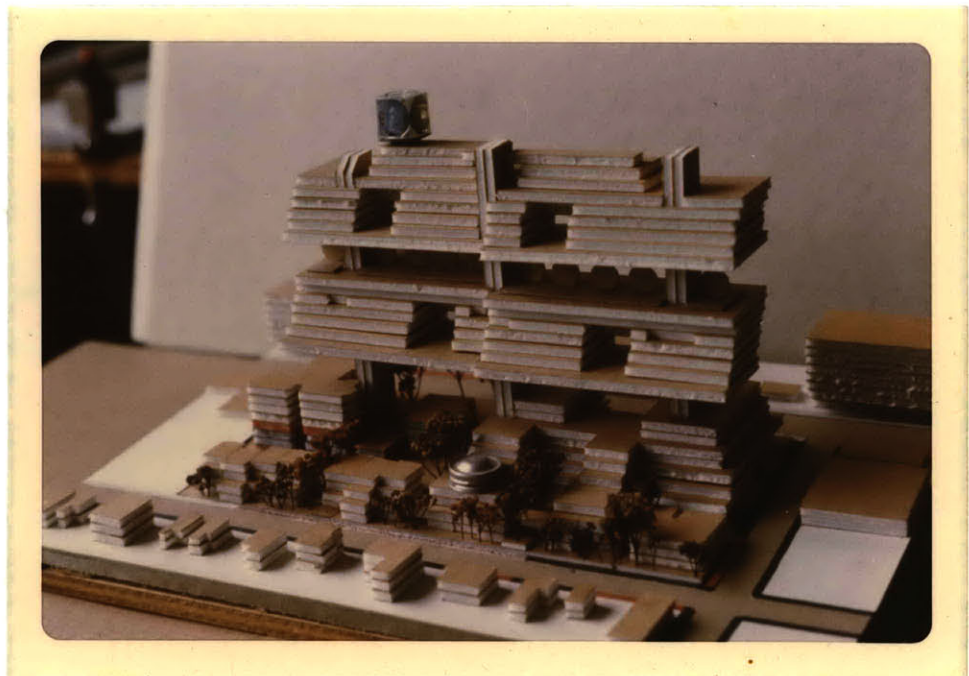

FIGURE 51

SMALL HOUSE AND ROOF DIFFUSER



VIEW FROM NORTH EAST
PROPOSAL FOR A 1200 PERSON COMMUNITY
WITH MIXED USES ON AN URBAN ARTERY.



VIEW FROM SOUTHEAST
TOTAL ENERGY IS SUPPLIED BY
UTILIZATION OF WIND AND SUN.
'A DESIGN WITH WIND AND SUN' FIGURE 52

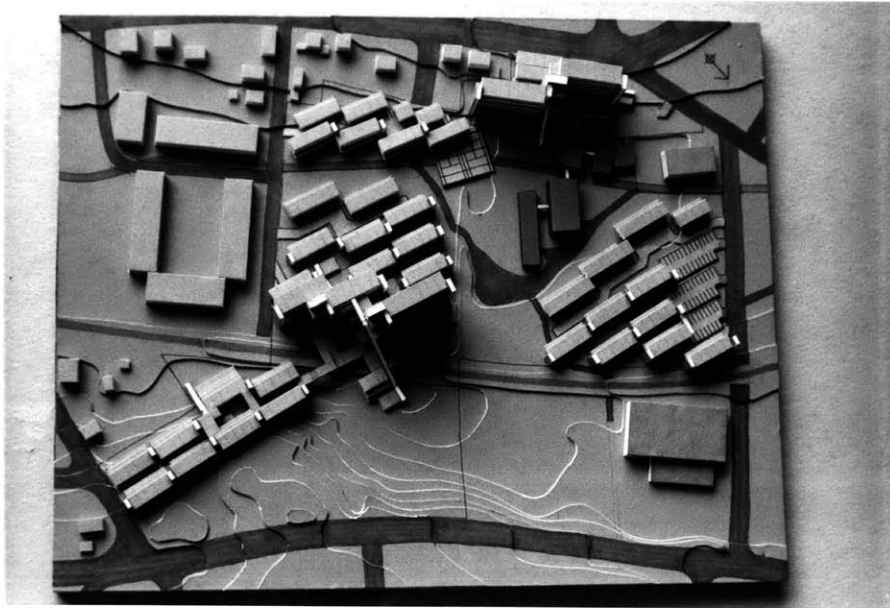

BIRD'S EYE VIEW
PROPOSAL FOR A 2000 PERSON COMMUNITY
WITH MIXED USES.



ELEVATED VIEW
TOTAL ENERGY IS SUPPLIED BY
WIND AND SUN UTILIZATION.

'A DESIGN WITH WIND AND SUN' FIGURE 53

3.0 COLLECTION AND UTILIZATION OF WIND ENERGY

This section includes an assessment of wind energy available, climatic analysis of the proposed site, collection and distribution of wind energy, and energy storage techniques. Applications of wind energy, wind architecture, energy conservation methods, and economics of wind energy usage shall be explored.

3.0 COLLECTION AND UTILIZATION OF WIND ENERGY

- 3.1 Wind Energy Available
- 3.2 Climatic Analysis
- 3.3 Collection and Distribution
- 3.4 Energy Storage
- 3.5 Wind Energy Applications
- 3.6 Wind Architecture
- 3.7 Energy Conservation
- 3.8 Economics and Costs

3.0 COLLECTION AND UTILIZATION OF WIND ENERGY

3.1 WIND ENERGY AVAILABLE

- (1) Check average wind velocity map for U.S.A. and world.
- (2) Check regional climatic data.
- (3) Check local weather bureau.
- (4) Make measurements on your site.
- (5) Energy available at turbine shaft:

$$P \text{ (KW)} = 2.0 \times 10^{-6} R^2 V_{\text{avg.}}^3 \quad \text{aerofoil rotor}$$

$$P \text{ (KW)} = 1.0 \times 10^{-6} R^2 V_{\text{avg.}}^3 \quad \text{drag rotor}$$

R = radius of turbine in feet

$V_{\text{avg.}}$ = average wind velocity in feet/sec.

Actual power available over a period of time will be twice the value calculated from the average velocity. Now we have:

$$P \text{ (KW) aero} = 4.0 \times 10^{-6} R^2 V_{\text{avg.}}^3$$

$$P \text{ (KW) drag} = 2.0 \times 10^{-6} R^2 V_{\text{avg.}}^3$$

- (6) Design velocity for turbine:

$$V_{\text{design}} = 1.7 V_{\text{avg.}}$$

This will give the greatest energy output per dollar invested in the wind turbine system.

- (7) Calculate your energy needs:

$$E \text{ (KWHR)}/\text{person}/\text{year} = 3,000 \text{ KWHR}/\text{person}/\text{year} \text{ (electrical)}$$

$$\text{Total power usage} = 8,000 \text{ KWHR}/\text{person}/\text{year} \text{ times}$$

$$\text{Year}/8,000 \text{ hours} = 1 \text{ KW } \text{ /person capacity}$$

- (8) Calculate the wind turbine size you will need by

using your velocity from (1) - (4) above:

$$1 \text{ KW} = 4 \times 10^{-6} R^2 V_{\text{avg}}^3 \quad (\text{See Appendix B})$$

POWER CAPACITY (KW)	(mph)	AVERAGE VELOCITY V_{avg} (fps)	TURBINE RADIUS (ft.)
1 KW capacity	7	10 fps	16 ft.
1 KW capacity	14	20 fps	5.5 ft.
1 KW capacity	21	30 fps	2.0 ft.

We see that by doubling the velocity, we can reduce the turbine radius by almost a factor of 3. This corresponds to a reduction in the swept area required for the turbine by a factor of 8.

Wind velocity is the most important factor in wind design! Use the fastest wind available to you. The size of the wind collector is also very important. Use the largest collector area possible. The design velocity of the collector is important, too! (Consult Figures *54-56 pages 125-127.*)

WIND MEASUREMENT ON ANY SITE

(1) Long Term Measurements

- Determine the potential energy output.
- The period of measurement should be greater than or equal to two years.

(2) Medium Term Measurements

- Establish wind structure for various weather conditions.

- Determine the best choice of wind collector.
- Period of measurement should range from 10 minutes to two years.
- Determine location of wind collector (wind velocity is usually highest in winter).

(3) Short Term Measurements

- Determine the detailed mechanical characteristics (gust design) for the turbine.
 - Period of measurement should range from one second to ten minutes. (period = 1 sec. - 10 min.)
 - Determine maximum design criteria for the collector.
- (From Szczelkun, Stefan A. Energy Scrapbook #3.1973.)

3.2 CLIMATIC ANALYSIS

- (1) Find a topographic map of your site.
- (2) Find places with best wind velocities.
- (3) Measure velocities directly on your site if you can find a small wind velocity measuring device.
- (4) Find prevailing winds, storm winds, and special winds for different seasons from your local climatic analysis guide.
- (5) Locate directions where local alterations to the prevailing wind occur. Always design with specific site information if you can get it.
- (6) Decide where best location for your built form is and how it relates to sun, wind, rain, ventilation, and to your site.
- (7) Diffuse collectors can orient themselves to the wind

direction, so choose the place with the most wind open to it.

- (8) Concentrating collectors may be fixed and should be oriented to make use of primary wind directions. Variations of 30° either side of prevailing directions will reduce output by only 10%.
- (9) Make certain that your wind collector and your built spaces will work together and not at opposite ends.
- (10) Wind velocities are more constant as you get higher above the ground.

3.3 COLLECTION AND DISTRIBUTION

- (1) Collectors can be diffuse or concentrated. Diffuse collectors like wide open spaces with lots of smooth flow around them and without any obstacles in their way to disturb the flow. Concentrated collectors concentrate the flow into a tight area in an effort to make smooth flow and increase the velocity through the collector (and thus increase the energy output). Concentrated collectors can be designed into built things; and they can even be placed between structures which already concentrate the flow! (i.e., milltops, roof tops, valleys, two existing forms).
- (2) Collectors can be airfoil type, drag type, or combined airfoil-drag types within the diffuse or concentrated groups.

- (3) Airfoil collectors are similar to airplane propellers, are most efficient in converting wind energy to useful work, must be carefully designed and made, cost a lot to make or buy, have a horizontal axis, and must be oriented into the wind.
- (4) Drag collectors are similar to wind anemometers used at weather stations, are half as efficient as airfoil collectors, can be easily designed and made, must have a vertical axis, need not be oriented into the wind, and do not cost a lot to make.
- (5) Airfoil-drag rotors combine aspects of propellers and anemometers, are of medium efficiency, must be carefully designed to combine both aspects, and cost only an average amount to make.
- (6) Concentrated collectors can usually double wind velocities so the power can be increased eight times.
- (7) Weight is an important factor in collector design because the collector will experience large forces when working in the wind and our support structure must be able to carry the load. Collectors should be as light weight as possible while support structures should be adequate to carry the load of the collector and associated equipment.
- (8) Converters range from generators to mechanical devices which convert wind energy into useful forms of energy for people to use: electricity, chemical work, or mechanical work.

- (9) Distributors range from electric wires to mechanical devices (tubes, links, belts) which can transfer energy to places or energy use.
- (10) Materials should be chosen according to what is available and most effective in your particular situation. There is no single best solution. So have fun and experiment with different ideas.
- (11) Collectors can be designed for average loads or peak loads depending upon the use of the energy. (Consult Figures *on pages 121 & 122*). Consumption should be calculated for one year, one season, one month, one week, one day, and one hour. Design capacity will depend upon the energy load placed upon the system by the use of the energy. Design for the most commonly occurring load. Example: a commercial space uses energy rather constantly over a ten hour period; while on the other hand a house uses concentrated energy over short periods of two hours in the morning, two hours at noon, and four hours in the evening. Average loads can be designed for by making loads spread out uniformly over long periods. Concentrated loads require higher design capacity and less constant use, or a standby system to help carry concentrated loads when they occur.

COMPARISON OF SAVONIUS ROTOR AND PROPELLOR TURBINE

<u>Savonius Rotor</u>	<u>Propellor Turbine(Stuart type)</u>
Drag rotor 33% maximum efficiency	Airfoil rotor 59% maximum efficiency
Non-directional Uses wind from any direction at any time.	Directional Must track the wind and this requires time and energy.
Spinning rotor gives gyroscope action but the rotor axis never moves.	Spinning propellor acts like gyroscope at high velocities and results in resistance to wind tracking plus large forces upon support structure and turbine blades.
Vertical axis	Horizontal axis
Conversion device can be located near ground.	Conversion device can be located in air on turbine shaft or linked mechanically to ground.
Easy access to conversion device.	Difficult access to conversion device.
Rotor shaft can be supported with one end on ground.	Turbine shaft must be supported up in the air.
Low rotor speeds	High rotor speeds
Maximum rotating speed is wind velocity	Maximum rotating speed is four to eight times wind speed
Large surface area presented to wind - (10-20 times turbine area).	Small surface area presented to wind
Same power at low speeds	Same power at high speeds
Less wear and tear at low speeds.	More wear and tear at high speeds
Power output must be stepped up to drive electrical conversion device	Power output need not be stepped up to drive electrical conversion device

Savonius Rotor

Propellor Turbine (Stuart
type)

No restarting problems with indirect (geared-up) shaft speed linkage
Rotor blades do not require careful design.

Restarting problems with direct shaft speed linkage

Turbine blades require careful design

Blades need minimal balancing

Blades must be balanced carefully

Low cost

High cost

Low technology
- 55 gallon oil drum

High technology carefully made propellers

5 mph minimum wind velocity for energy output

7 mph minimum wind velocity for energy output

3.4 ENERGY STORAGE

- (1) Determine the amount of storage you will need from the estimated periods of time you will be receiving no usable winds.
- (2) Decide what capacity you wish your system to operate at. Maximum efficiency might be to utilize energy directly from the wind collector, with a minimum storage capacity to save energy when more is available than can be used. Standby system employed at full capacity when wind energy is not available are reasonable considerations.
- (3) Storage capacities vary from 1 to 5 days of normal use depending upon the situation and use which the energy is being put to (40 sq.ft. supply 4 days energy).
- (4) Calculate your energy consumption; for one year, one month, one week, one day, and one hour. Designing for peak hourly consumption will utilize the system at full capacity for only 10% of the time while designing for yearly consumption will use the system at full capacity 90% of the time and require some other source of energy for peak daily and hourly periods.
- (5) Storage devices range from storage batteries to super flywheels. Storage batteries are heavy, bulky, messy, heat sensitive, short-lived, and expensive. Reservoirs of water or mass are less heavy, bulky, messy, heat sensitive, and are long-lived and inex-

pensive. (1 KWHR = 3,000,000 ft.lb. = 1500 ft.tons)
 Flywheels are light, compact, not messy, not heat sensitive, long-lived, and expensive.

(6) Energy might be fed directly into the power network and credit received in return which could be applied to your power bill. Losses would occur in transmission and in redistribution.

(7) Energy Storage Capacity:

<u>EFF. (%)</u>	<u>STORAGE DEVICE</u>	<u>CAPACITY (BTU/lb.)</u>	<u>COST (BTU/\$)</u>
70%	Battery	18-35 BTU/lb.*	25 BTU/\$
35%	Flywheel	20-90 "	35 "
67%	Compressed air	100 "	25 "
50%	Fuel cell	90 "	35 "
67%	Water reservoir	0.25 " (100' head)	18 "
67%	Mass reservoir	0.25 " (100' head)	18 "
30%	Power network	45 " **	1,000"

* Future prediction for battery capacity is: 350 BTU/lb.

**Estimation by D.R. Coonley. 1972.

Above information from: NSF/NASA, December 1973, Wind

Energy Conversion Systems.

CONVENTIONAL BATTERY PERFORMANCE

SYSTEM	PERFORMANCE		CYCLE LIFE	PROJECTED COST	PROBLEMS
	WH/LB	W/LB			
Lead-acid	10	20-30	1500	\$80/KWH	
Nickel-iron	25	50	?	\$100/KWH	gassing, main- tenance, ef- ficiency
Nickel-zinc	30	150	200-400	same as lead-acid?	life

METAL-GAS BATTERY PERFORMANCE

SYSTEM	PERFORMANCE		PROBLEMS
	WH/LB	W/LB	
Iron-air	40-50	10-20	cathode corrosion, life
Zinc-air	40-50	10-20	life, cost
Nickel-hydrogen	30-40	?	volume, life
Zinc-oxygen	50-60	10-30	life, cost
Cadmium-oxygen	30-40	?	life, cost
Zinc-chlorine	50-75	40-60	life

ALKALI METAL-HIGH TEMPERATURE BATTERY PERFORMANCE

SYSTEM	PERFORMANCE		CYCLE LIFE	PROBLEMS
	WH/LB	W/LB		
Sodium-sulfur (Beta alumina)	80-100	80-100	200-2000	life, costs
Sodium-sulfur (Glass)	80-100	80-400	100 +	life, materials, stability
Lithium-sulfur	100	> 100	2000	materials cor- rosion, costs
Lithium chlorine (Carb-Tek) [®]	50	>> 100	100	life

From: NSF/NASA, December 1973, Wind Energy Conversion Systems

3.5 WIND ENERGY APPLICATIONS - Safety Design

- (1) Sails are safest. Sails are soft, flexible and unlikely to hurt anything if they fly apart.
- (2) Wind velocity is usually higher in winter than in summer.
- (3) Icing up of the turbine can be expected to occur in winter cold periods.
- (4) Turn off, feather, or take down your wind turbine if you are leaving the wind turbine; unless it is equipped with a fail safe governing control device which will respond to wind situations without personal attendance.
- (5) Test your collector support system to be certain that the support will hold the wind collector up under all conditions which the collector may be expected to experience.
- (6) Do not try to take on more work than you are capable of handling; or fixing if you do make a mistake.

Wind Energy Applications

- (1) Wind turbine - water pump (Holland, Denmark)
- (2) Wind turbine - mill wheel (Greece, Holland)
- (3) Wind turbine - generator - battery storage
(Europe and U.S.A., Australia, Russia)
- (4) Wind turbine - generator - power network
(Russia and U.S.A.)

MANUFACTURERS OF WIND COLLECTORS

- (1) Aerowatt - "Aerowatt"
Paris, France
Aero-blade rotors
- (2) Davey-Dunlite Company - "Quirks"
Adelaide, South Aus ralia
(Subsidiary of P.Y.E. Industries)
Sales Pty. Ltd. of Melbourne
- (3) Domenico Sperandio
via Cimarosa 13-21
58022 Follonica (GR)
Italy
Aero-blade rotors
- (4) Elektro G.M.B.H. - "Windgenerator"
Winterthur, Switzerland
Aeor-blade and Savonius rotors
- (5) Lubing Maschinenfabrik
Barnstorf (Bremen Nearby)
West Germany
Aero-blade rotors
- (6) Winco - "Wincharger"
Dyna Technology, Inc.
Sioux City, Iowa

DESIGNERS OF WIND COLLECTORS

(1) Alternative Sources of Energy

Route 1, Box 36 B
Minong, Wisconsin 54859

(2) Windworks

Box 329, Route 3
Mukwonago, Wisconsin 53149
U.S.A.

(3) Sencenbaugh Wind Electric

c/o Jim Sencenbaugh
(673 Chimalas Drive) P.O. Box 11174
Palo Alto, California 94306

(4) Solar Wind Company

c/o Henry Clews
R.F.D. #2
Happytown Road
East Holden, Maine 04429
(Agent for: Dunlite, Elektro, Dyna Technology,
and Sencenbaugh Wind Electric)



(5) University of Cambridge

Department of Architecture
1 Scroope Terrace
Cambridge CB2 1 PX (G.B.)

(6) V.I.T.A.

3706 Rhode Island Ave.
Mount Rainier, Maryland 20822

3.6 WIND ARCHITECTURE

- (1) Dutch windmills: winglike; wind turbine and mill in one building. 
- (2) Greek windmills: sails; wind turbine and mill in one building. 
- (3) Danish windmills: wind turbine and mill in one building.
- (4) Arabia: wind collectors in houses; controlled flow in and out; flow through ventilation. 
- (5) Eskimo igloo: smooth surfaces with low flow resistance and minimum surface area to volume enclosed.
- (6) African huts: massive earth walls to resist transfer of heat; poles around outside for shading; thatch roofs with lots of air pockets to resist transfer of heat; controlled ventilation.
- (7) East Asian houses: raised off of ground to gain surface area and to use wind flow to cool the house; large roof overhangs which deflect wind into the house; controllable ventilation with louvers at top and bottom of house walls; flow through ventilation.

3.7 ENERGY CONSERVATION

I. CONSUMPTION OF ENERGY PER PERSON

<u>Country</u>	<u>Consumption per person</u>
U.S.A.	35.0 x 10 ⁷ BTU/yr.
Canada	29.0 " "
Japan	9.0 " "
USSR	14.5 " "
Oceania	14.0 " "
East Europe	13.5 " "

(Consumption of Energy Per Person - continued)

<u>Country</u>	<u>Consumption per person</u>
West Europe	12.0 x 10 ⁷ BTU/yr.
Other Americas	3.0 " "
Communist Asia	1.5 " "
Africa	1.1 " "
WORLD AVERAGE	6.0 x 10 BTU/yr.

II. DISTRIBUTION OF CONSUMPTION		Efficiency of	
		<u>Consumption</u>	<u>Conversion</u>
U.S.A. - Domestic		10%	70%
Commerical		10%	70%
Industrial		30%	60%
Transport		25%	20%
Electric generator		25%	30%
TOTAL		100%	

III. SOURCES OF ENERGY		<u>Renewable (?)</u>	
U.S.A. - Coal	20%	no	1 million yrs.
Oil	43%	no	1 million yrs.
Gas	32%	no	1 million yrs.
Hydro	4%	yes	
Nuclear	1%	no	1 million yrs.
TOTAL	100%		

IV. POTENTIAL SOURCES OF ENERGY		<u>Renewable (?)</u>
Solar		yes - daily
Wind		yes - daily
Tidal		yes - daily
Geothermal		yes - 1,000 years
Wood		yes - 40 years

V. POTENTIAL SAVINGS IN THE U.S.A.

50% of the energy consumed in the U.S.A. is wasted as heat, pollution, or trash. Use of "waste" energy could save money and supply renewed sources of energy. Careful design with Nature, more "people-services", and more efficient use of materials would result in a real savings.

VI. The construction of an average house (1,200 square feet) in the U.S.A. requires 54 KWH per square foot of finished construction (1973). The power to run the completed house requires 27 KWH per square foot per year (1973). We see that energy expenditure to run the house will equal the total expenditure for construction in only two years.

HOME ANALYSIS INFORMATION ¹

(1 This information is taken from a report of the Real Gas & Electric Co., Inc., Environmental Energies, Inc., 1974)

Here is some information to help you figure how much power you will really need in your wind powered homestead. First, a basic electrical formula that will help you juggle Watts, Volts, and Amps around:

$$\text{Watts} = \text{Amps} \times \text{Volts}$$

From which follows: $\text{Amps} = \text{Watts}/\text{Volts}$ and $\text{Volts} = \text{Watts}/\text{Amps}$

Watts are a measure of power. A 75 watt bulb requires 75 watts of power to run it. If it is a standard 115 volt bulb, then it will draw $75/115$ or .65 amps of current. If it is a 12 volt, 75 watt bulb, however, it will draw $75/12$ or 6.25 amps. This illustrates that more current is needed to get the same power at a lower voltage. This is important to keep in mind because the size wire required in a given application is determined solely by the current which will be flowing through it and not the power. So, if you're

running a wire which will power four 75 watt bulbs, for example, at 115 volts this would only represent 2.6 amps, whereas at 12 volts it would be 25 amps, and might require special heavy duty wiring. This is also something you'll want to consider when choosing a voltage for your system.

Another relationship you will want to understand is the connection between kilowatt-hours and amp-hours and how this measure of total energy consumed relates to the volts, amps, and watts of a specific appliance in your house. A 100 amp-hour battery will deliver 1 amp for 100 hours, or 10 amps for 10 hours, etc. An amp-hour is just what it sounds like: amps x hours. But, as we have seen, the current in amps that a certain item draws depends on the voltage it is operating at. So an amp-hour rating in itself doesn't tell you very much about how much power you can store in the batteries. In order to determine this, you must also specify a voltage - such as 100 amp-hours at 115 volts. Now, since we know that amps times volts equals watts, we can infer that amp-hours time volts will equal watt-hours which in fact it does! And 1000 watt-hours equals one kilowatt-hour, and this is what the Electric Company bills you for every month. A kilowatt-hour is nothing more than 1000 watts of power used for a period of one hour (or 500 watts for 2 hours, etc.).

Now if this isn't all crystal clear, a careful study of the following tables should help.

APPLIANCES	POWER IN WATTS	CURRENT REQUIRED IN AMPS		TIME USED PER MO. (HR.)	TOTAL KW-Hrs. PER MO.
		AT 12V	AT 115V		
Air Conditioner	1566	1300.	13.7	74.	116.
Blanket, electric	177	14.5	1.5	73.	13.
Blender	350	29.2	3.0	1.5	0.5
Blower (forced air furnace)	450	37.	3.9	300.	135.
Broiler	120	120.	12.5	6.	8.5
Clothes Dryer	4856	405.	42.0	18.	86.
Coffee Pot	894	75.	7.8	10.	9.
Dishwasher	1200	1200.	10.4	25.	30.
Drill (1/4" elec.)	250	20.8	2.2	2.	.5
Fan (attic)	370	30.8	3.2	65.	24.
Freezer (15 cu.')	341	28.4	3.0	29.	10.0
Freezer (15 cu.')	440	36.6	3.8	33.	14.7
(frostless)					
Frying Pan	1196	99.6	10.4	12.	15.
Garbage Disposal	445	36.	3.9	6.	3.
Heat, electric baseboard, avg. size home (1500 ft. ²)	10,000	832.	87.	160.	1600.0
Iron	1088	90.5	9.5	11.	12.
Lightbulb, 75 watt	75	6.25	.65	320.	2.4
Lightbulb, 40 watt	40	3.3	.35	320.	1.3
Lightbulb, 25 watt	25	2.1	.22	320.	.8
Oil Burner, 1/8 HP	250	20.8	2.2	64.	16.
Radio	70	5.7	6.61	100.	7.

APPLIANCES	POWER IN WATTS	CURRENT REQUIRED IN AMPS		TIME USED PER MO. (HR.)	TOTAL KW-HRS. PER MO.
		AT 12V	AT 115V		
Range	12,207	1020.00	106.00	8.	98.
Record Player (tube)	150	12.5	1.3	50.	7.5
Record Player (solid state)	60	5.0	.52	50.	3.
Refrigerator- Freezer (14 cu.')	326	27.2	2.8	29.	9.5
Refrigerator- Freezer (14 cu.'- frostless)	615	51.3	5.35	25.	15.2
Skill saw	17000	83.5	8.7	6.	6.
Sun lamp	279	23.2	2.4	5.4	1.5
Television, B/W	237	19.8	2.1	110.	25.
Television/color	332	27.6	2.9	125.	42.
Toaster	1,146	95.5	10.0	2.6	3.
Typewriter	30	2.5	.26	15.	.45
Vacuum Cleaner	630	52.5	5.5	6.4	4.
Washing Machine (automatic)	512	42.5	4.5	17.6	9.
Washing Machine (wringer)	275	23.	2.4	15.	4.
Water Heater	474	38.3	4.0	89.	40.
Water Pump	460	37.2	3.9	44.	20.

POWER, CURRENT, & MONTHLY KW-HR CONSUMPTION OF VARIOUS HOME APPLIANCES

122

3.8 ECONOMICS AND COSTS

(1) Electric power costs: (USA)

3¢ - 6¢/KWHR (1974)

\$100-\$500/KW capacity installed (1974)

(2) Wind power costs: (World)

10¢-15¢/KWHR (1974)

\$500-\$1500/KW capacity installed

(3) Now, let's explore the "real" costs of these two power sources!

(Information from Real Gas & Electric Co., Inc.)

<u>ELECTRICITY</u>	<u>WIND POWER</u>
Fuel consumption great	<u>No</u> fuel consumption
Pollution caused**	<u>No</u> pollution
Does ^{not} have renewability	Is renewable
Wastes energy (70% waste in production)	<u>No</u> waste
Expensive materials	Expensive to inexpensive materials
Requires much labor	Requires much labor
Noise at production point	Noise at production point
Vibration created	Vibration created
Must have a means of being stored	Must have means of being stored
Could be considered unsightly, visual noise	Could be considered unsightly, visual noise

(4) Energy cost = (R + C + M)/P

R = rate of annual charges /KW*

L = construction cost/KW

M = maintenance cost/KW

P = annual energy: KWHR/KW

Life of plant = 10-30 years

* (10-15%)

** "Air pollution costs a family of four about \$80 per year in addition to their electric bill."

ECONOMIC COMPARISON OF WIND ENERGY AND FOSSIL FUELS

Wind Energy

Collector plant
\$500-\$1500/KW

Fuel
0.0 (sun)

Energy
\$.10-\$.25/KWHR

Materials
diffuse
medium technology

Pollution
none

Visual aspect
diffuse

Structure
\$ 25/KW

Noise
diffuse
some street noise

Vibration
diffuse

Life
30 - 40 years

Fossil Fuels

Power plant
\$100-\$500/KW

Fuel
\$100/lb.

Energy
\$.03-\$.05/KWHR

Materials
concentrated
high technology

Pollution
lots!

Visual aspect
concentrated

Structure
none

Noise
concentrated
hurricane/railroad

Vibration
concentrated

Life
50-75 years



AVAILABILITY OF WIND ENERGY ON EARTH
 ANNUAL SPECIFIC OUTPUT OF WIND TURBINES RATED AT 25 MPH
 FIGURE 54 (FROM: WIND ENERGY CONVERSION SYSTEMS. NASA/NSF. 1973.)

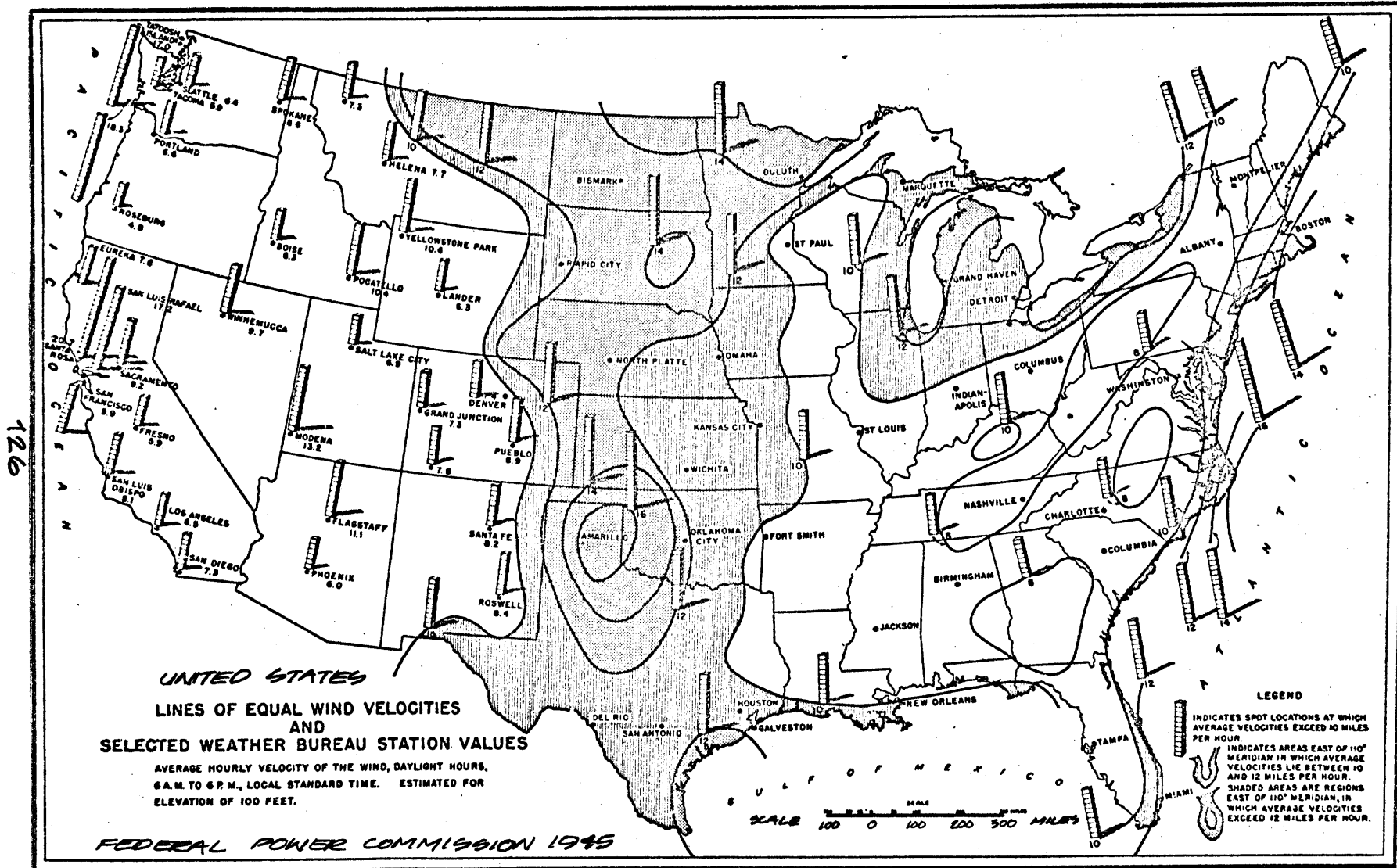
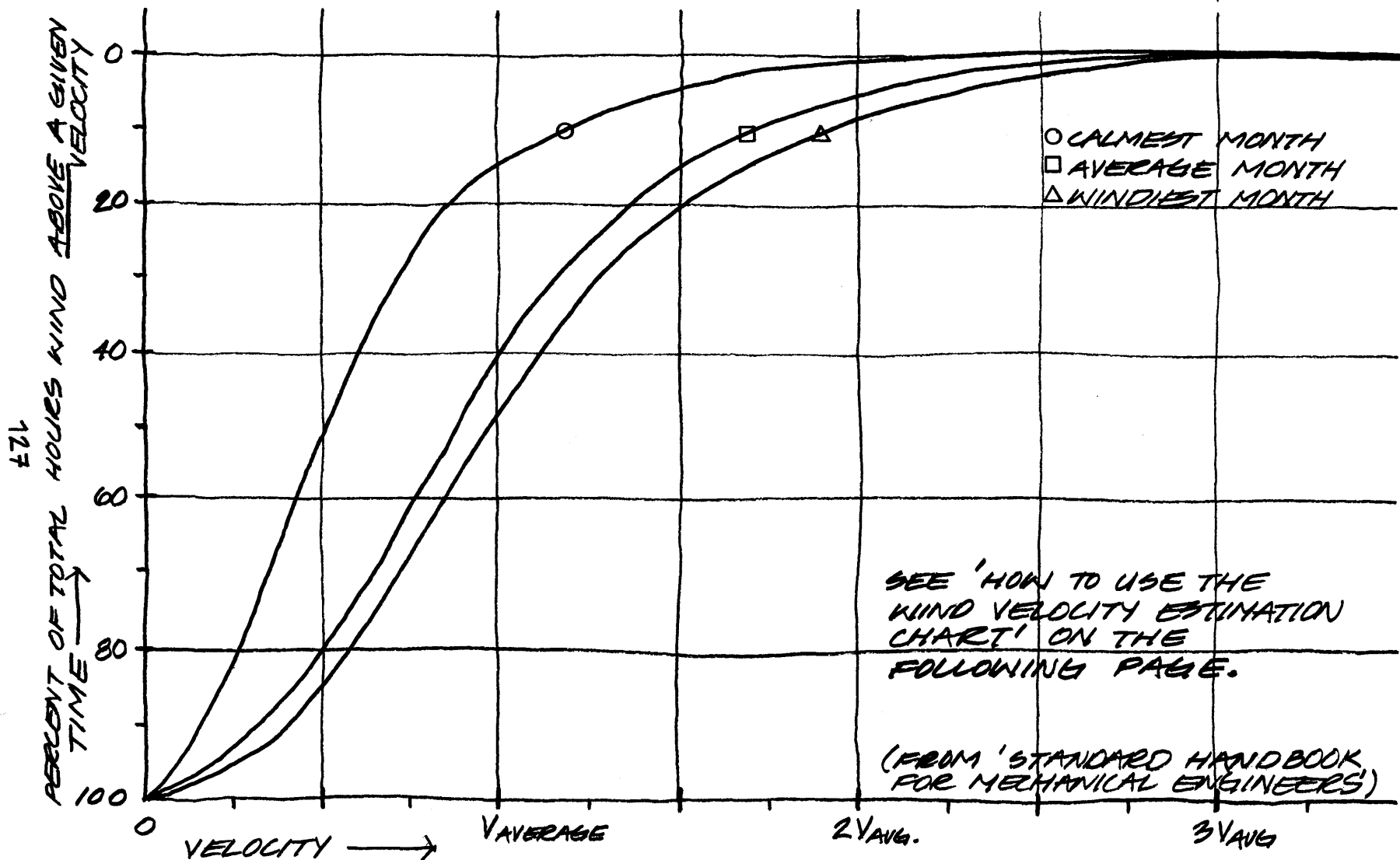

FIGURE 55



WIND VELOCITY ESTIMATION CHART

FIGURE 56

HOW TO USE THE WIND VELOCITY ESTIMATION CHART

- ① FILL IN THE AVERAGE MONTHLY WIND VELOCITY FOR YOUR SITE AT 'VAVERAGE' ON THE CHART.
- ② NOW, FILL IN '2 VAUG.' WITH TWICE THE AVERAGE MONTHLY WIND VELOCITY FOR YOUR SITE. THEN FILL IN '3 VAUG.' WITH THREE TIMES THE AVERAGE MONTHLY VELOCITY, AND THE INCREMENTS IN BETWEEN.
- ③ NOW FIND THE MINIMUM VELOCITY FOR WHICH YOUR TURBINE WILL PRODUCE POWER ON THE 'VELOCITY' AXIS ALONG THE BOTTOM OF THE PAGE. MINIMUM VELOCITY FOR PROPELLOR COLLECTORS IS USUALLY 7 MPH, AND 5 MPH - 6 MPH FOR SAVONIUS COLLECTORS.
- ④ MOVE VERTICALLY FROM THIS MINIMUM DESIGN VELOCITY UNTIL YOU REACH THE WIND SITUATION YOU ARE DESIGNING FOR: THE CALMEST MONTH, AVERAGE MONTH, OR THE WINDIEST MONTH. USUALLY THE AVERAGE MONTH IS USED.
- ⑤ NOW MOVE HORIZONTALLY TO THE LEFT UNTIL YOU REACH THE 'TIME' AXIS.
- ⑥ READ OFF THE PERCENT OF TOTAL HOURS YOUR WIND COLLECTOR CAN BE EXPECTED TO PRODUCE ENERGY.
- ⑦ NOW MULTIPLY THE NUMBER OF HOURS IN THE TIME PERIOD UNDER CONSIDERATION BY THE PERCENT OF HOURS YOUR COLLECT CAN PRODUCE POWER. 1 YEAR = 8760 HOURS.

PLENTY OF WIND

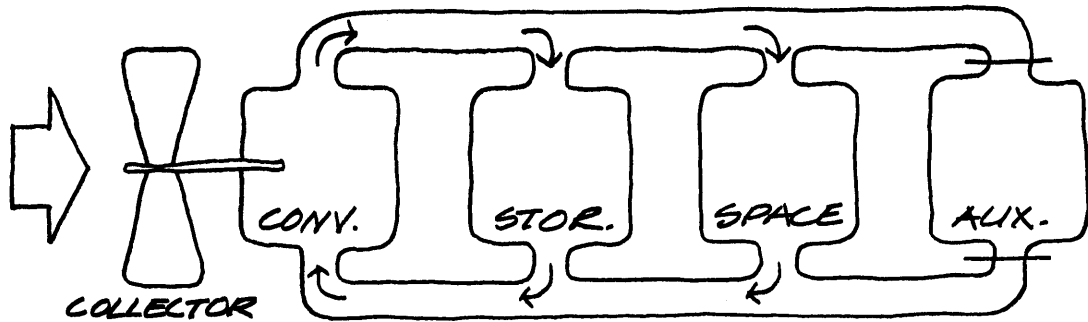

ADEQUATE WIND

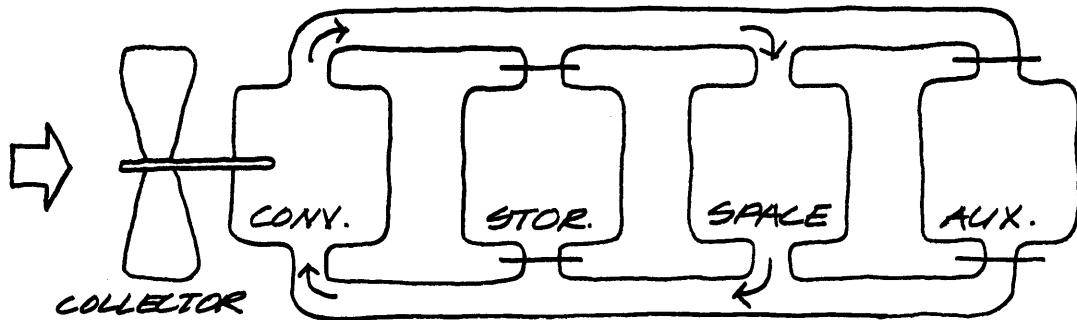

INADEQUATE WIND - STORAGE FULL

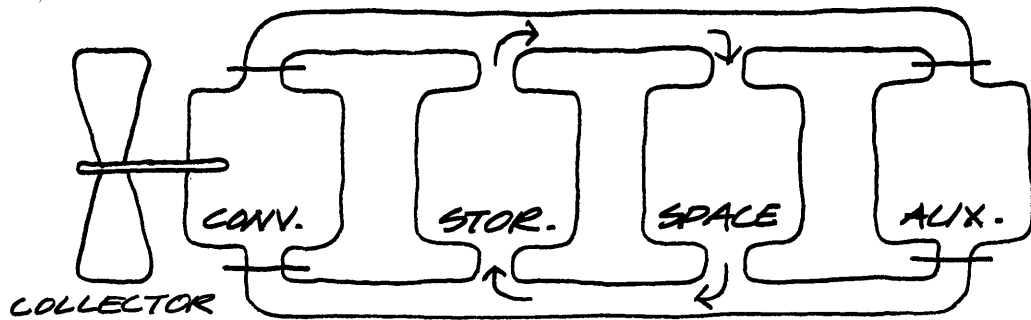

INADEQUATE WIND - STORAGE EMPTY

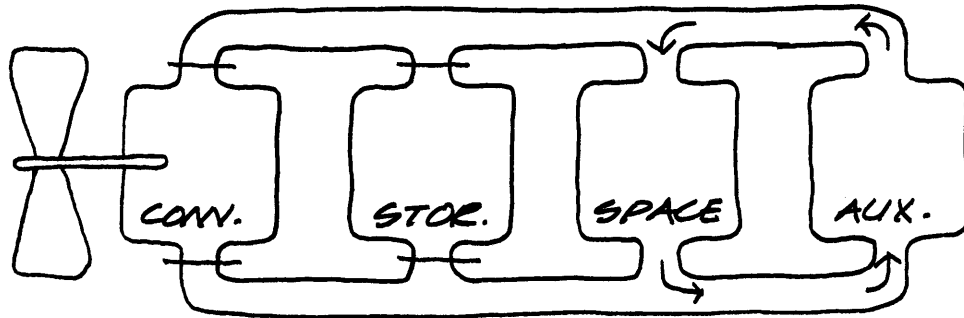

WIND SYSTEM OPERATION FIGURE 57

WIND DRIVEN GENERATORS FROM SWITZERLAND (Information from Elektro G.M.b.H. of Winterthur)

Model No.	Rated Output In Watts	Rated Windspeed in MPH	Monthly Output KW-HRS	Voltages Available	Propeller Diam. Ft.	No. Blades	Price F.O.B. Boston
W 50	50	40	3	DC 6,12,24	1'5"x3'2"	**	\$1020.
W250	250	40	10	DC 12,24,36	2'2"x4'9"	**	1285.
WV 05	600	20	55	DC (12),24,36	8'4"	2	1290.
WV 15G	1200	23	75	DC(12),24,36,48, 65,115	9'10"	2	1695.
WV 25G	1800	24	110	DC(24),36,48,65, 115	11'6"	2	1940.
WV 25/3G	2500	25	140	DC(24),36,48,65, 115	12'6"	3	2380.
¹⁵⁰ WV 35G	4000	24	230	DC 48,65,115	14'5"	3	2750.
WVG 50G	6000	30	325	DC 65,115	16'5"	3	3275.
WV 15W	1200	23	75	AC 1ph.115 30-70cy.	9'10"	2	2045.+
WV 25D	2000	25	115	AC 3ph.115 35-65cy.	11'6"	2	2475.+
WV 35D	3500	23	225	AC3ph.115,230 40-60cy.	13"10"	3	3450.+
WVG 50D	5000	23	320	AC3ph.115, 230 50-70cy.	16'5"	3	3840.+

* Average monthly output in an area with 10 mph average windspeed.

** Vertical Axis Savonius Rotor

+ Price includes voltage regulator.

(5% extra charge for voltages in parenthesis)

From WINCO Division of DYNA TECHNOLOGY, INC.

FIGURE 5B

4.0 APPENDICES

This section includes appendices to the text.

4.0 APPENDICES

- 4.1 Appendix A - Wind Turbine Performance: Theoretical and Empirical Bases
- 4.2 Appendix B - Example Wind Collector Calculation
- 4.3 Appendix C - Wind Potential

4.1 APPENDIX A

WIND TURBINE PERFORMANCE: Theoretical and Empirical Bases

THEORETICAL:

Betz - Momentum theory (concerns the decelerations in the air traversing the wind turbine disk).

Drzwiecki - Blade element theory (concerns the air forces produced on an element of the turbine blade).

EMPIRICAL:

- Models in a wind tunnel
- Models on a moving vehicle
- Full size wind turbines in real situations

Energy contained in the wind ($P_w = \text{K.E. in wind}$)

$$P_w = 1/2 \pi R^2 \rho V^3$$

where R = radius of turbine in feet

ρ = mass density of air ($\approx .002$ -fps units)

V = velocity of wind in fps units (feet per second)

$$P_w = \text{watts} = .00314 R^2 V^3$$

Energy available from the wind (P_a)

$$P_a = 0.592 P_w = 0.00186 R^2 V^3$$

This may never be exceeded. (Based on momentum and blade-element theories.)

Energy usable from the wind (P_u)

The percentage of power removed from the air is proportional to the power coefficient C_p .

$$P_u = C_p \times P_a = C_p \times 0.592 P_w$$

Energy is obtained from the wind by slowing down the air. Multiblade wind turbines have maximum efficiency at low-tip speeds: tip speed ratio approx. 0.5 - 2.5.

$$\text{Tip speed ratio} = 2\pi n R/V$$

where n = revolutions per second

R = radius of turbine

V = velocity of wind

Propellor type wind turbines have maximum efficiencies at high tip speeds: tip speed ratio approx. 4.0 - 6.0.

POWER COEFFICIENT

<u>Turbine</u>	<u>C_p (%)</u>	<u>Decimal multiplier</u>
(1) High-speed prop type	42%	.42
(2) Darrieus	35%	.35
(3) Savonius	31%	.31
(4) American multiblade	30%	.30
(5) Dutch 4-arm	16%	.16

(NOTE: see Mech. Eng., Nov. 1925 and March 1927)

An example of a wind turbine:

Stuart propellor-type two blade turbine

- High power turbine
- $C_p = 42\%$ (or .42)
- At $3/4$ radius blade is thin airfoil with an angle of 4 degrees and a chord width of $R/6$
- Tip speed equals 6 to 8 times the wind speed
- Light weight construction

- Inexpensive to buy or build
- Widespread use for driving electric generators either direct or geared
- Above 10 feet diameter, 3 or 4 blades may be used
- 3 or 4 blades are less powerful, but avoid gyroscopic vibration when the mill veers with changing winds
- Much less starting torque is obtained (as is not the case with the multiblade type) and an unloading clutch is required when applied to a reciprocating pump drive
- Very large windmills are vulnerable when stopped during a tempest because wind creates bending moments at the blade roots proportional to the cube of the turbine diameter (d^3).
- A single-blade propellor overcomes this difficulty by floating downwind (like a weathervane) when stopped

PERFORMANCE PREDICTION OF WIND

Turbines:

$$\begin{aligned}
 \text{Horsepower} &= C_p \frac{\rho \times 4 \times R^2 V^3}{2200} \\
 &= C_p \frac{\rho \times D^2 V^3}{2200}, \quad \rho = 0.002 \\
 &= 3.63 \times 10^{-6} \times C_p \times R^2 V^3
 \end{aligned}$$

where R = feet, V = fps, C_p = power coefficient = .42-.16

Two-Blade Turbines: (of Stuart type described previously)

where R = feet, V = fps, C_p = power coefficient

Geared to an electric generator of 70% efficiency

$$KW = 0.15 \times 10^{-5} \times R^2 V^3 \quad \text{where rpm} = 52.5 \, V/R$$

$$= 0.376 \times 10^{-6} \times D^2 V^3 \quad \text{where rpm} = 105 \, V/D$$

Energy usable in wind:

$$P_u = .592 P_w E_t E_c \quad \text{where } P_w = \text{kinetic energy in the wind}$$

and, E_t = efficiency of turbine

E_c = efficiency of conversion mechanism

E_t = maximum of approx. 0.70

E_c = maximum of approx. 0.90

$$\text{Thus, } P_u = 0.592 \times 0.70 \times 0.90 \times P_w$$

$$P_u = .37 P_w$$

And, thus, only 37% of the kinetic energy in the wind is available for our use. We should, therefore, be careful how we use wind energy, and we should use it well.

(NOTE: All information from Baumeister & Marks standard handbook for mechanical engineers.)

Kinetic energy in wind:

$$P_w = 3.14 \times 10^{-6} R^2 V^3$$

where R = radius of turbine in feet

V = velocity of wind in ft./sec.

P_w = power in kilowatts

Energy available to blade of turbine:

$$P_a = .592 P_w$$

$$= 1.86 \times 10^{-6} \times R^2 V^3$$

$$P_a = 1.9 \times 10^{-6} \times R^2 V^3$$

Energy usable at the turbine shaft:

$$P_u = E_t \times 1.9 \times 10^{-6} \times R^2 V^3$$

Power usable from the wind at the turbine blades:

Comparing equations from various sources:

I. Standard Handbook for Mechanical Engineers

$$P_u \text{ (KW)} = 1.5 \times 10^{-6} \times R^2 \times V^3$$

where, there is 70% turbine blade efficiency

70% generator efficiency

R = turbine radius in feet

V = wind velocity in feet/sec. (fps)

$$\begin{aligned} \text{Thus, } P_u &= 1.5 \times 10/7 \times 10^{-6} \times R^2 \times V^3 \\ &= 2.1 \times 10^{-6} R^2 V^3 \end{aligned}$$

II. Windworks

$$P_u \text{ (KW)} = 6.7 \times 10^{-7} \times A \times V^3$$

where, there is 70% turbine blade efficiency

and, A = swept area of turbine in square feet (ft.²)

$$A = R^2$$

R = turbine radius in feet

V = wind velocity in feet/sec. (fps)

$$\begin{aligned} \text{Thus, } P_u \text{ (KW)} &= 6.7 \times 10^{-7} \times R^2 \times V^3 \\ &= 2.1 \times 10^{-6} \times R^2 \times V^3 \end{aligned}$$

III. Solar Wind

$$P_u \text{ (KW)} = 2.1 \times 10^{-6} \times R^2 \times V^3$$

where, there is 70% turbine blade efficiency

and where, R = turbine radius in feet, and

V = wind velocity in feet/sec. (fps)

IV. Design With Wind (D.R. Coonley)

$$P_u \text{ (KW)} = 2.0 \times 10^{-6} \times R^2 \times V^3 \quad (R = \text{ft.}, V = \text{ft./sec.})$$

This is the power capacity of the turbine. Run for one hour in a wind velocity V_0 , we would get:

$$2.0 \times 10^{-6} \times R^2 \times V_0^3 \text{ KWhours of energy.}$$

POWER IN THE WIND

- (1) There is a well-defined group of wind velocities which predominate in each month, and may be called the prevalent winds. There is also a well-defined group of winds which contain the bulk of the energy of each month called energy winds.
- (2) Energy winds produce about three-fourths of the total energy of a given month. (Even in a calm summer month, 70% of the energy comes from winds which blow only 42% of the time.)
- (3) Energy winds blow 2 out of 7 days (29%).
- (4) Prevalent winds blow 5 out of 7 days (71%).
- (5) Energy winds blow at velocities of about 2.3 times those of the prevalent winds.
- (6) For each month the energy of the varying winds adds up to double the amount that would be computed from

the average hourly velocity of that month. Thus we can double the energy output calculated using the average monthly velocity for each given site.

- (7) 7 mph yearly average is the minimum wind velocity practical for propellor-type turbines. 5 mph yearly average is the minimum wind velocity practical for light multi-blade turbines and savonius type rotors.

(Consult Figures

NOTE: Above information from Marks' Standard Handbook for Mechanical Engineers.

Now we can write some rule of thumb equations:

Equations for Aero Rotor:

$$KW = 2.0 \times 10^{-6} R^2 V^3 \quad \text{where } R = \text{radius in feet, and}$$

V = average wind velocity
in fps (ft./sec.)

$$KW = 7.5 \times 10^{-4} R^2 V^3 \quad \text{where } R = \text{radius in meters, and}$$

V = average wind velocity
in mps (m/sec.)

Equations for Drag Rotor:

$$KW = 1.0 \times 10^{-6} R^2 V^3 \quad (\text{ft, fps})$$

$$KW = 3.73 \times 10^{-4} R^2 V^3 \quad (\text{m, mps})$$

$$KW = 3.2 \times 10^{-7} A V^3 \quad (\text{ft}^2, \text{fps})$$

$$KW = 1.2 \times 10^{-4} A V^3 \quad (\text{m}^2, \text{mps})$$

Now design wind speed is:

$$1.7 V_{avg} = V_{design}$$

ENERGY OUTPUT

Multiply KW capacity times number of hours per year to find energy output. And, let's say we get approximately 8,000 hr/yr.

Example: 1 KW (capacity) x 8000 hr./yr. = 8,000 KWHR/yr.

ACTUAL OUTPUT

Actual output will be twice output calculated from V_{avg} and design velocity of $1.7 V_{avg}$.

Example: 2 x 8,000 KWHR/yr. = 16,000 KWHR/yr.

$KW = 4.0 \times 10^{-6} R^2 V^3$	Aero rotor (fps, ft.)
$= 1.5 \times 10^{-3} R^2 V^3$	" " (m/sec, m)
$KW = 2.0 \times 10^{-6} R^2 V^3$	Drag rotor (fps, ft.)
$= 7.5 \times 10^{-4} R^2 V^3$	" " (m/sec, m)

RULES OF THUMB FOR ESTIMATING WIND POWER CAPACITY

4.2 APPENDIX B

EXAMPLE WIND COLLECTOR CALCULATION

We have from Appendix A:

$$P(\text{KW}) \text{ capacity} = 4 \times 10^{-6} R^2 V^3$$

We need 1 KW capacity. So,

$$1 (\text{KW}) = 4 \times 10^{-6} R^2 V_{\text{avg}}^3 \quad \text{where } R = \text{ft. and } V_{\text{avg}} = \text{ft./sec.}$$

We can look at our conversion table for mph and fps:

<u>mph</u>	<u>fps</u>
3.5	5.0
7.0	10.0
10.5	15.0
14.0	20.0
17.5	25.0
21.0	30.0

Let's say that $V_{\text{avg}} = 10$ fps for our site. (This is about the minimum velocity for a propellor wind turbine.) Now we can solve for turbine radius "R";

$$\begin{aligned} R^2 &= \frac{1}{4 \times 10^{-6} V_{\text{avg}}^3} = \frac{1}{4 \times 10^{-6} \times 10^3} \\ &= \frac{1}{4 \times 10^{-3}} = 0.25 \times 10^3 = 250 \end{aligned}$$

$$R = \sqrt{250}$$

$$R = 16 \text{ ft.}$$

Now, let's try $V_{\text{avg}} = 20$ fps. Then we get,

$$\begin{aligned} R^2 &= \frac{1}{4 \times 10^{-6} V_{\text{avg}}^3} = \frac{1}{4 \times 10^{-6} \times (20)^3} \\ &= \frac{1}{4 \times 10^{-6} \times 8,000} = \frac{1}{3.2 \times 10^{-2}} \\ &= 3.0 \times 10 = 30 \quad \text{So, } R = \sqrt{30} = 5.5 \text{ ft.} \end{aligned}$$

We find that doubling the velocity reduces the required turbine radius by almost a factor of 2.8!

4.3 APPENDIX C

WIND POTENTIAL

Power Available At A Turbine Shaft (KW)

AERO ROTOR			RADIUS OF TURBINE (FT.)					
mps	fps	mph	5.	10.	15.	20.	25.	30.
2.1	7.	5.	.017	.068	.15	.27	.42	.61
4.2	14.	10.	.135	.54	1.2	2.1	3.3	4.8
6.7	22.	15.	.52	2.1	4.7	8.4	13.1	18.9
8.8	29.	20.	1.2	4.8	10.8	19.2	30.0	43.2
11.0	36.	25.	2.3	9.3	21.0	37.2	58.0	83.5
13.4	44.	30.	4.2	17.	38.	68.	106.	153.
15.5	51.	35.	6.6	26.5	60.	106.	165.	238.
17.6	58.	40.	9.7	39.	87.	156.	244.	351.
20.0	66.	45.	14.4	57.6	129.	230.	360.	528.

Power capacity (KW) = $2.0 \times 10^{-6} R^2 V^3$ where R = radius of turbine in feet, and V = velocity of wind in feet/second.

Drag rotor = 0.5 efficient as aero rotor for same radius when height is 2 times the radius.

NOTE:

The actual energy available over a period of time will be twice the energy computed from this chart. Actual energy will be reduced by the efficiencies of the conversion and storage systems.

5.0 TOPICAL BIBLIOGRAPHY AND REFERENCE LISTING

WIND

Behavior

Wax, M.P. "An Experimental Study of Wind Structure With Reference to the Design and Operation of Wind Driven Generators". Electrical Research Association, pub. no. C/T 114. 1956.

Climatology (General)

Brooks, C.E. P. Climate Through the Ages. (Dover Publications, Inc. : New York) 1970.

Claiborne, Robert. Climate, Man, and History. (W.W. Norton & Co., Inc.: New York) 1970.

Critchfield, Howard J. General Climatology. (Prentice-Hall, Inc.: Englewood Cliffs, New Jersey) 1966.

Geiger, Rudolf. The Climate Near the Ground. (revised ed., Harvard University Press: Cambridge, Mass.) 1957.

U.S. Dept. of Commerce. Climatic Atlas of the United States. (Environmental Science Services Admin. Env. Data Service: Washington, D.C.) 1968.

Microclimatology

Givoni, B. Man, Climate, and Architecture. (Praeger: New York) 1969.

Olgay, Victor. Design With Climate. (Princeton Univ. Press: Princeton, New Jersey) 1970.

Measurement

Irminger, J.O.V. and Chr. Nøkkentved., trans. by Alexander



C. Jarvis and R. Halfden-Nielsen. Wind-Pressure on Buildings. (Danmarks Naturvidenskabelige Samfund: Copenhagen) 1930.

Putnam, Palmer C. Power From the Wind. (D. Van Nostrand Co., Inc.: New York) 1948.

Wind Tunnels

Cermak, J.E. et al. Problems of Atmospheric Shear Flows and Their Laboratory Simulation. (Fluid Dynamics and Diffusion Laboratory: Colorado State University) Technical Report CER 66JEC-BAS-EJP-GJB-HC-RNM-S117, May 1966.

General

Aynsley, R.M. "Wind Effects on High and Low Rise Housing". Architectural Science Review. September, 1973.

Ibid. "Wind Flow Around Buildings". March, 1971.

Carbon, J.M. Shelterbelts and Wind breaks. (Faber and Faber Ltd.) 1965.

World Meteorological Organization. Energy From the Wind. Technical Report No. 4. 1954.

WINDMILLS

Historic Perspectives

Oliver, Paul. "Windmills of Murcia". Shelter. Dec. 1973.

Reynolds, Joh. Windmills and Watermills. (Praeger Publishers: New York) 1970.

Large-Scale Installations

Heronemus, W.E. Power from Offshore Winds. Proceedings of the 8th Annual Marine Technology Society Conference: Washington, D.C. 1972.

Putnam, P.C. Power From the Wind. (Van Nostrand Co.: New York) 1948.

Thomas, Percy H. Fitting Wind Power to the Utility Network. Federal Power Commission Report No. 099558. Feb. 1954.

High-Speed Electrical Generators

Clews, Henry. Electric Power from the Wind. Solar Wind Publication. 1973.

Vertical Axis

Simonds, M.H. and A. Bodek. Performance Test of a Savonius Rotor. Brace Research Institute pub. no. T.10. Jan. 1964.

Shrouded

Lilley, G.M. and W.J.Rainbird. A Preliminary Report on the Design and Performance of Ducted Windmills. British Electrical and Allied Industries Research Assoc., Technical Report C/T 119. 1957.

Meyer, Hans. Wind Energy. Dome Book II. 1971.

Home-Built

Meyer, Hans. "Windmills: **And Here's** An Advanced Design That You Can Build". Popular Science. Nov. 1972.

Mother Earth News.

"Free Power From the Wind". No. 17. p. 60.

No. 5. p. 42.

No. 6. p. 60.

"Henry Clews' Wind Powered Homestead". No. 18. p. 25.

Sencenbaugh, J. "Sencenbaugh O₂ Powered Delight". Mother Earth News. No. 20.

Volunteers for International Technical Assistance (VITA).
College Campus, Schenectady, New York. US/AID Fan Blade
Windmill. publ. no. 1113.3; Essex Pan Blade Windmill.
pub. no. 11133.1; Helical Sail Windmill. pub. no. 11131.1;
Savonius Rotor Windmill. pub. no. 11132.1.

Commercial

Dyna Technology, Inc. Instructions for Assembly of Models
622 (6 volt) and 1222 (12 volt) Wind Driven Generators.

Aerowatt S.A. (Paris) Wind Blown Generator. (company report).

"Windpower Plants". Popular Science. No. 1972. p. 103.

Brace Airscrew

Chilcott, R.E. "Notes on the Development of the Brace Air-
screw Windmill as a Prime Mover". The Aeronautical Journal
of the Royal Aeronautical Society. 73. No. 700. April 1969.
pp. 333-334; or, Brace Research Institute pub. no. R.38.

Conferences

Association for Applied Solar Energy. World Symposium on
Applied Solar Energy. (Stanford Research Institute: Stanford,
California) 1956.

Savion, Joseph M. (ed.) Wind Energy Conversion Systems,
Workshop Proceedings. NSF/NASA. December, 1973.

Spanides, A.G. and A.D. Hatzikadidis. Solar and Aeolian
Energy. Proceedings of the International Seminar on Solar
and Aeolian Energy- Septmeber, 1961. (Plenum Press: New
York) 1964.

NASA. Proceedings of the NSF/NASA Conference on Wind Driven
Generators. Lewis Research Center. June, 1973.

UNESCO. Wind Power and Solar Energy. Proceedings of the New Delhi Symposium - Paris, 1956.

United Nations Publication. "New Sources of Energy". Proceedings of the Conference, Rome, 21-31 August 1961. in Wind Power. Vol. 7. (United Nations) 1964. (out of print).

U.S. Dept. of Commerce. Technical Meeting Concerning Wind Loads on Buildings. Proceedings of Building Science Series No. 30. (National Bureau of Standards: Washington, D.C.) 1970.

Foreign Languages and Translations

Lanoy, H.M. Les Aeormototeurs Modernes. (Girardot & Cie: Paris) 1947.

General

Chilcott, R.E. "Putting the Wind to Work". Engineering. Nov. 22, 1968.

Fales, E.N. "Windmills". Standard Handbook for Mechanical Engineers. (McGraw-Hill: New York) 1967.

McCaul, J. "Windmills . Environment" Vol. 15, No. 1. Jan. 1973. pp. 13-20.

Meyer, Hans. "Wind Energy". Architectural Design. Dec. 1972.

AERODYNAMICS

General

Glauert, H. The Elements of Aerofoil and Airscrew Theory. (Cambridge University Press: Cambridge, England) 1959.

ELECTRICAL

Thomas, Percy H. Electric Power From the Wind. (Federal Power

Commission: Washington, D.C.) 1945.

TOWERS

Proceedings of the International Research Seminar on Wind Effects on Buildings and Structures - Sept. 11-15, 1967-Ottawa. (University of Toronto Press: Toronto, Canada) 1968.

STORAGE

Flywheels

"Flywheels". Scientific American. 229, no. 6. Dec. 1973. pp. 17-23.

Rabenhorst, D.W. Superflywheel Kinetic Energy Storage System. (John Hopkins University: Applied Physics Laboratory) No. APL/JHU RP 001. March, 1973.

General

Allison, H.J., R.G. Ramakumar, W.L. Hughes. Energy Storage Research at Oklahoma State University. Proceedings of the Midwest Power Symposium at Iowa State University, Ames. October, 1970.

Hughes, W.L., C.M. Summers, H.J. Allison, J.B. West, W.J. Fabrycky. "Energy Storage ...Key to Our Economic Future". Engineering Research. 1962.

EQUIPMENT

McGuinness, William J. and Benjamin Stein. Mechanical and Electrical Equipment for Buildings. (Wiley and Sons: New York) 1971.

GENERAL

Alternative Sources of Energy. Route 1, Box 36B, Minong, Wisconsin. (monthly publication)

"Energy and Power". Scientific American publication.
(W.H. Freeman Co.: New York) September, 1971.

Fagan, John J. The Earth Environment. (Prentice-Hall,
Inc.: Englewood Cliffs, New Jersey) 1974.

Hottel, Hoyt C. and J.B. Howard. New Energy Technology -
Some Facts and Assessments. (MIT Press: Cambridge, Mass.)
1971.

Lynch, Kevin. Site Planning. (MIT Press: Cambridge, Mass.)
1971.

New Alchemy Institute. The Journal of the New Alchemists. 1973.

NSF/NASA Solar Energy Panel. Solar Energy as a National
Energy Resource. (University of Maryland: Department of
Mechanical Engineering) 1972.

"Regional Climate Analysis and Design Data - X. Boston".
Dept. of Education and Research of the AIA. in Supplement
to Bulletin of the American Institute of Architects. March,
1951.

Szczelkun, Stefan A. Energy. Survival Scrapbook #3. (Shocken
Books: New York) 1973.

WINDWORKS. Wind Energy Bibliography. Box 329, Route 3,
Mukwonago, Wisconsin. October, 1973.
(General organization for this bibliography came from this
source.)